

Design Quarterly 63

"A Clip-On Architecture"

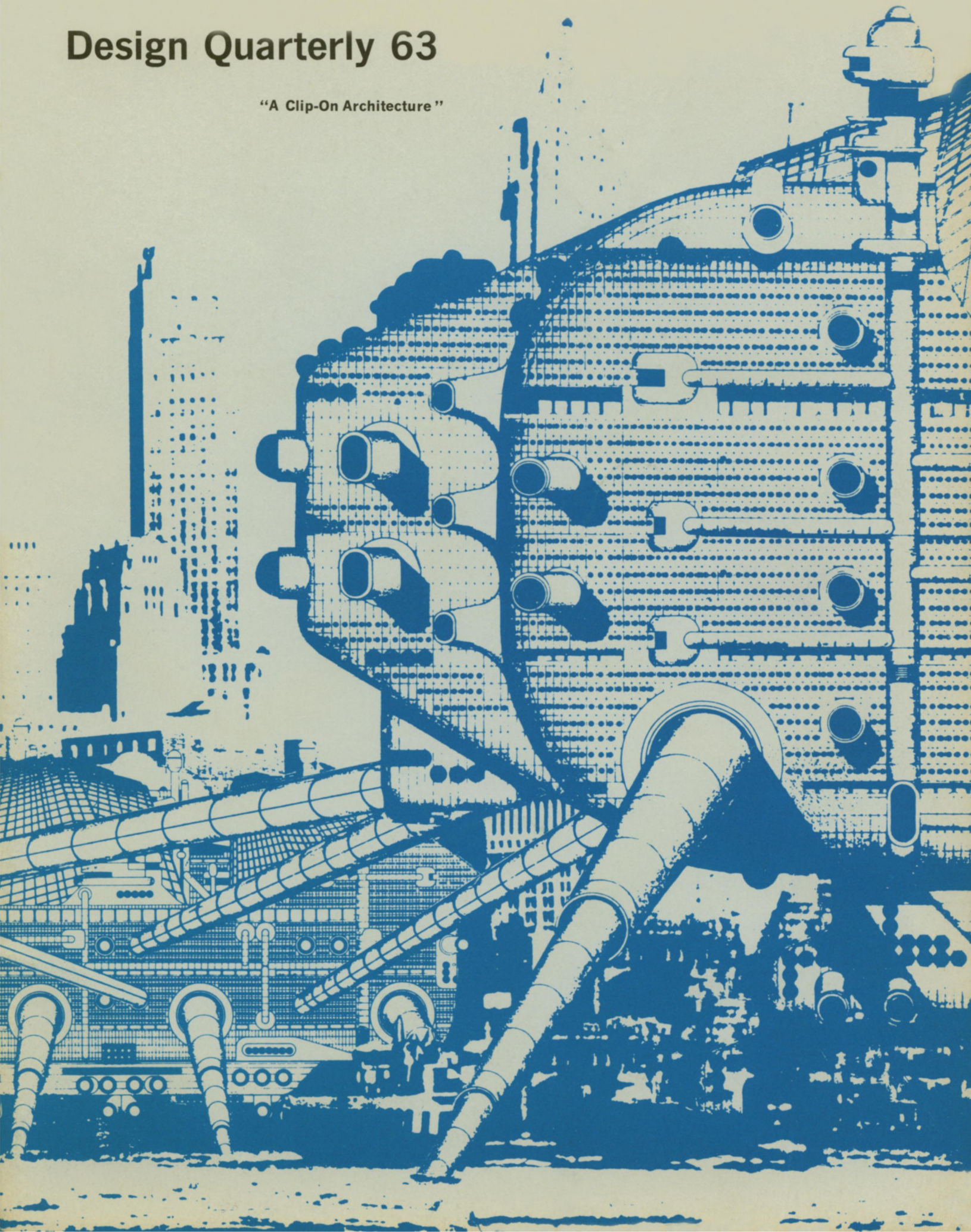

DESIGN QUARTERLY 63
Editor: Peter Seitz
Circulation: Elsa M. Larson

Design Quarterly is indexed in Art Index
Subscription rates are 4 issues \$3.50, 8 issues \$6.25, 12 issues \$9.00
Single issues \$1, Double issues \$2.
Foreign postage \$1.00 for 4 issues. Design Quarterly is published by
Walker Art Center, 1710 Lyndale Avenue South, Minneapolis, Minnesota 55403
Change of address: To insure receiving all copies, give the old address as
well as the new one and allow five weeks for change to become effective.

WALKER ART CENTER
1710 Lyndale Avenue South
Minneapolis, Minnesota 55403
Martin Friedman, Director

T. B. WALKER FOUNDATION
Trustees

Archie D. Walker, President
Walter W. Walker, Vice-President
Hudson D. Walker, Vice-President
Dana C. Smith, Vice-President
Justin V. Smith, Secretary and Treasurer
Mrs. Malcolm A. McCannel, Assistant Secretary
and Assistant Treasurer
Theodore S. Walker, Assistant Secretary
Mrs. Theodore S. Walker
Mrs. Willis J. Walker
Mrs. James van Loben Sels
Brooks Walker
Mrs. Wellington Henderson

Honorary Trustee
H. Harvard Arnason

Members
Mrs. Calvin Yeates
Mrs. Calvin Goodrich

WALKER ART CENTER BOARD OF DIRECTORS

Louis N. Zelle, President
Donald W. Judkins, First Vice-President
David H. Preus, Second Vice-President
Martin Friedman, Secretary-Treasurer
Pierce Butler
Mrs. C. Merritt Case, Jr.
John Cowles, Jr.
Harold Field
Norton Hintz
Mrs. Malcolm A. McCannel
Mrs. Richardson B. Okie
Mrs. Edmond R. Ruben
William G. Shepherd
Justin V. Smith
Archie D. Walker
Walter W. Walker
Mrs. O. Meredith Wilson
David M. Winton

Ex-Officio
Gordon A. Mikkelson
Hon. Arthur Naftalin
Bruce Smith

Cover: Indeterminacy—the essential intellectual component of any Clip-On Architecture— includes indeterminacy of location, as shown in this vision of walking metropolises by Ron Herron and Bryan Harvey of the British Archigram group.

Design Quarterly 63

**A ON
CLIP- ARCHITECTURE**

Walker Art Center Minneapolis, Minnesota

TR. 11 EXP-BIG STORE
 ADD 3 UNITS 522 AT
 783 6284
 TEMP COVER 8 FROM
 30.11 TO 12.1
 TRANSPORTATION FREQU
 ENCY 19.86
 CAPACITY 64/83 80P
 FEED BACK GOODS SUP
 LINES 56
 VOL CHANGE 1
 SUPPLY DPT 28.326
 APPLY RATE 66
 SUB-ZONAL AREA
 CAPACITY CONAT 97
 FLOW 23 INTERNALLY
 EXTRA FLOW 477-48
 POSITION 20.477-48
 TO 21.04 NY 0231174
 MOUNT 827 DER. TO
 DISCONNECT CRANEWAY
 133 EMP 286 TO 397
 SELF SUFFICIENCY LEV
 45.88 FOR 86 DAYS
 REGULATION CHANGE-1
 MIGRATION -10.8/11.2
 MOBILIZATION AREA C38
 FLOOR CORNER SHOP TPR
 FLOOR LEVEL L OVER
 POINT 37 CAP 112
 INTERCONNECTOR TYPE
 7/A VOLUME 124/SEC
 FROM L TO G AT 3.71
 MONTHLY TIMING FOR
 MONTHS 3-6
 MAIN TOWN/LEISURE ZN
 INCR. TO 2000 PPH
 COUNTER FOR CORR ZN
 OVERALL BIRTH RT IN
 CORP-DEATH RATE 59%
 AD3. 64 THRU.22 TO
 ALL PROGS-RE-RATE
 HAB. UNIT 83659 CHANG
 APPLY WALL 3L
 REMOVE 12.3.87.0900
 REPLACE WITH TYPE C3
 IMP. SUPPLY CONDITION
 AGE OF POPULATION IN
 SUB-ZONE 2476764 WRS
 AT RATE -1.008%
 EXPAND ACTIV. SEC4C/D
 FAULT REPORT
 TRAVEL TOR. 38/72/95
 SINC-DECEL-OUTSTEP
 PARTS HA/K/261.384V
 ALTERNATE ROUTE SCN
 FARM PROG. FACTORY
 PROD UNIT CF846
 INCR-STOCK 7C TO 700
 FOOD VALU TARGET AT
 MONTH B APP-RATE 420
 SHOP TREND..ZONE 72
 INC. IN HARDSTUF. UP
 OVER PROD 100% CAPC
 RELOCATE TRM. 17% AT
 ZONE 73
 ZONE 54 FALL -5.75%
 ABSTRACT OF TYPE 58D
 ADD 3 UNITS 522 AT 7
 283 & 6284
 TEMP COVER 88 FROM
 30.11 TO 12.1
 COVER REC-AREA H29
 73 FROM DAY 19 FOR 7
 REDUCE TEMP SUB-ZON
 132.59 HY 3.5 JEG.C
 POWER SUPPLY
 MINIMUM THRU 4 YEARS
 24936 PUMP CAP. MAX
 AT 06.00 M/SEC PROD
 OPT. PUMP 03.08
 INTEGRATE INTERN AT
 HIGH CENTRE INC. 450
 RE-FLOW TO CAPACITY
 PRODUCTION UNIT R37
 EXPAND TO LEVEL B/84
 ACCOM. DRAFT NT. 420
 POP. CHANGE +38.2 AT
 SUPPLY STR. INCR. 64
 .TRANS. +12.45
 NAT. R. TRANS +0.08/D
 TEL. COMM. L. TO 58-29
 MR. TO 08.04
 TRAF. RT. B38APP. CAP
 773.2 AT 28.09.31
 INCR-FLOW CAP. 8 PTS
 CTR. 11 EXP-BIG STORE
 ADD 3 UNITS 522 AT 7
 283 & 6284

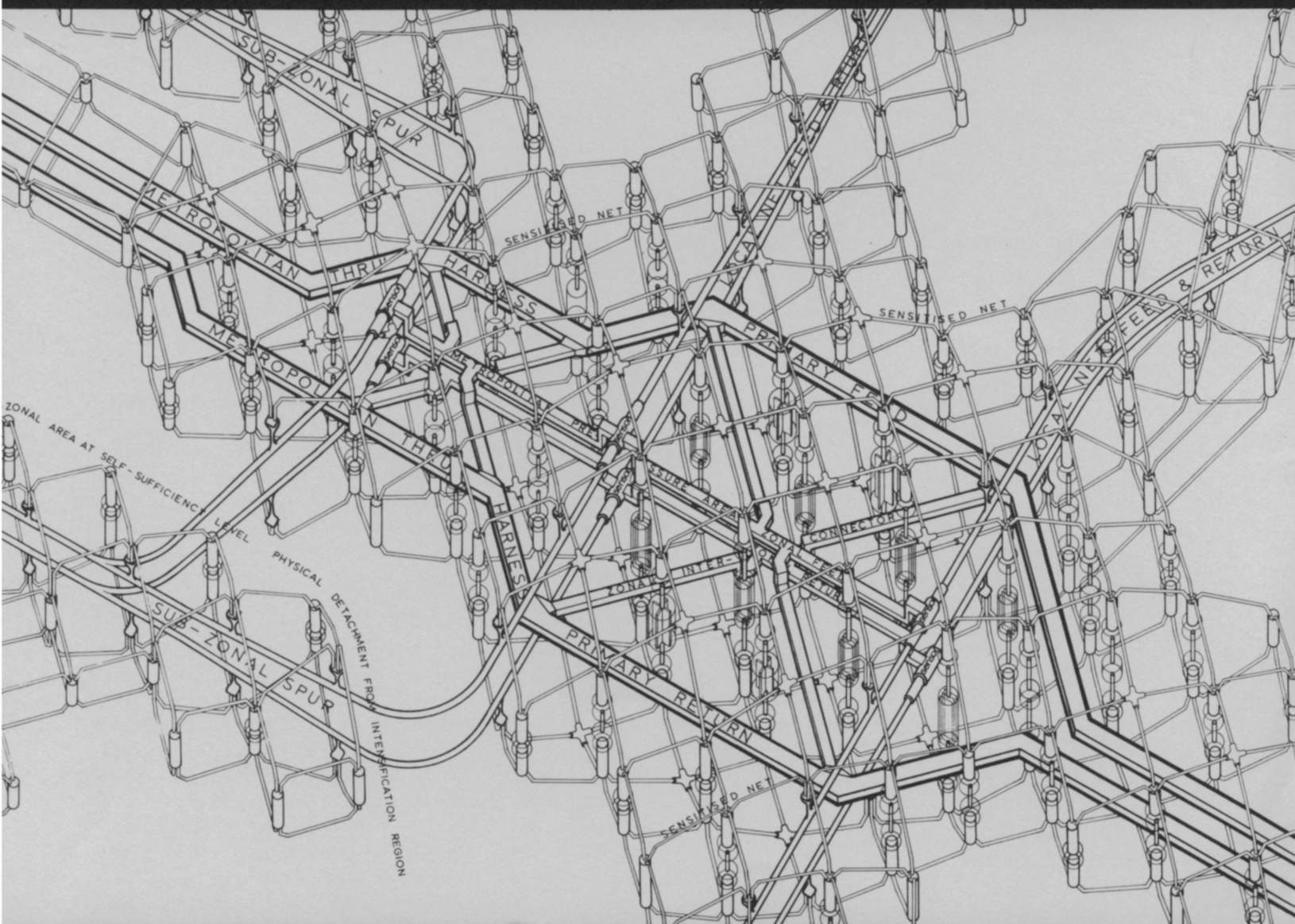

Computer City: a synthesized metropolis with electronic changeability. The city as a balanced network of forces, interacting and changing. A sensitized net detects changes of activity, responds and feeds back information to program the computer for reactions. ("Archigram" 5, Dennis Crompton)

The scarcity of examples of an “endless,” or “indeterminate,” architecture in the United States (almost none besides Eero Saarinen’s Technical Center at General Motors exists) demonstrates that, at present, there is an unfortunate lack of interest here in architecture which is anonymous and not intended as monuments of individual self-expression.

In this issue of DESIGN QUARTERLY, Dr. Reyner Banham, critic, historian and longtime assistant editor of the renowned English magazine *Architectural Review*, presents an illustrated account of the development of “Clip-On Architecture” in England. P.S.

A CLIP-ON ARCHITECTURE

Observers of the British design scene must have wondered what kind of architectural thinking may have emerged to parallel the rise of Pop and Op art in their London manifestations. The architects who are contemporary with pioneer Pop artists like Richard Hamilton are now well-known—James Stirling and James Gowan, for instance, are the 1965 winners of the Reynolds Aluminum prize and Alison and Peter Smithson will design the new British Embassy in Brasilia.

Those who fit into the mid-twenties to late-thirties age-bracket remained hidden from the public eye (because of the absence of finished buildings) until the Living City exhibition, sponsored by the Gulbenkian Foundation, at the London Institute of Contemporary Arts in 1963. This exhibition was organized and assembled by the team of architects and designers now known as the “Archigram Group,” named after its irregular magazine Archigram. Like the exhibition, the recent issues of their magazine reveal an architectural vision—bright, mechanistic and big-city oriented—that is easily comparable with the visual language of painters like Peter Phillips, Derek Boshier and Joe Tilson. However, the quick comparison may too easily conceal the fact that this vision, which is shared in a different form by English architects like Cedric Price as well, stands upon a fairly deeply-rooted tradition of architectural speculation that goes back to 1950, or even further than that. Out of that tradition comes one cluster of speculative ideas that unites in the concept of an architecture of indeterminate form assembled from expendable components—the Clip-On or Plug-In concept.

The origins of the British theory that the architecture of technology should consist of endlessly repeated structural grids lay in observation of U. S. trends of the early 1950s. Yet practically the only surviving examples of the “endless aesthetic” are the facades of the buildings at General Motors Technical Center by Eero Saarinen.

Musing on the potentialities of United States technology in a special issue of the *Architectural Review* entitled “Man Made America,” Gerhard Kallman observed: “The question of whether—with emerging new realities of the anonymous, of endlessly linked chains, of fugal and progressional rhythms—all centristic concepts, be they geometric or irregular, will give way to new concepts, is now becoming a very burning one . . .”

That was December 1950, and subsequent history shows that the question burned nobody in the United States—where a generation of architects, genially misled by Philip Johnson, turned to old-world centristic concepts to solve their problems of architectural composition, and thus produced the current flourishing revival of that monumentalism that the 1930’s had hopefully proclaimed dead. Among that generation is Mr. Kallman, whose part in the design for the new Boston City Hall shows that questions of anti-centricity barely singed him personally. The very few surviving examples of anonymous, endlessly linked, non-centric architecture that the United States produced in that period of the early 1950’s—the long facades of Eero Saarinen’s technical center at General Motors, for instance—are now unfortunately among the most disregarded and despised architecture that post-war America has produced.

The Idea of Endlessness

But if the question failed to burn in the United States, it fired a number of imaginations on the other side of the Atlantic, and this article of Kallman’s is part of the pedigree



Though the famous schools designed by Hertfordshire County Council after World War II were mostly small and compact, they made great use of the aesthetic of repetition (windows, wall panels, classroom pavilions) and often implied an “endless” planning discipline.

In the type exemplified in the diagram at right, where classrooms (shown tinted) are strung along an irregular corridor from the entrance and commons facilities, there is nothing in the design method as such to prevent indefinite extension in the direction of the arrow by repetition of further classrooms. This is an early demonstration of the usefulness of the indeterminate approach.

of the concept of an “indeterminate architecture.” Under various names this intellectual concept has been circulating in Britain for the past fifteen years (and is therefore probably due to be taken up shortly as an exciting novelty in the United States).

One of the reasons why the concept took hold in Britain was that a number of disparate trends were already pulling in that direction. Among them was the simple desire to be cautiously noncommittal among the uncertainties of post-war reconstruction. Thus, the famous Hertfordshire prefabricated schools were not only conceived in terms of a seemingly unlimited repetition of standard glazed wall-units, but of a theoretically unlimited repetition of identical classroom units along a corridor as well.

Contemporary anti-formal (not to say anti-architectural) concepts such as “the neutral technological frame,” which were current among British architectural students at the time, were also understood to be endlessly repetitive; buildings that could be cut to length as required, and be neither better nor worse aesthetically for being ten units long or a thousand—because the aesthetic point was the fact of visual repetition anyway.

Six months after Kallman’s article, many of these vague notions and floating concepts were brought together and given a massive intellectual stiffening in a paper read at the Architectural Association, London, by Richard Llewelyn Davies (now both a Professor and a Lord) who has long been the *eminence grise* of the scientific and systematic approach to both architectural design and constructional methods. Under the title “Endless Architecture,” he presented not only his own view but that of a group of persons, including Sir Leslie Martin (under whom he had worked on prefabricated railway stations) and John Weeks, who will appear later in the narrative as Llewelyn Davies’ partner in architectural practice. The topic that these three had been turning over among themselves, with a wealth of erudition that included a Mondrian painting which appeared during

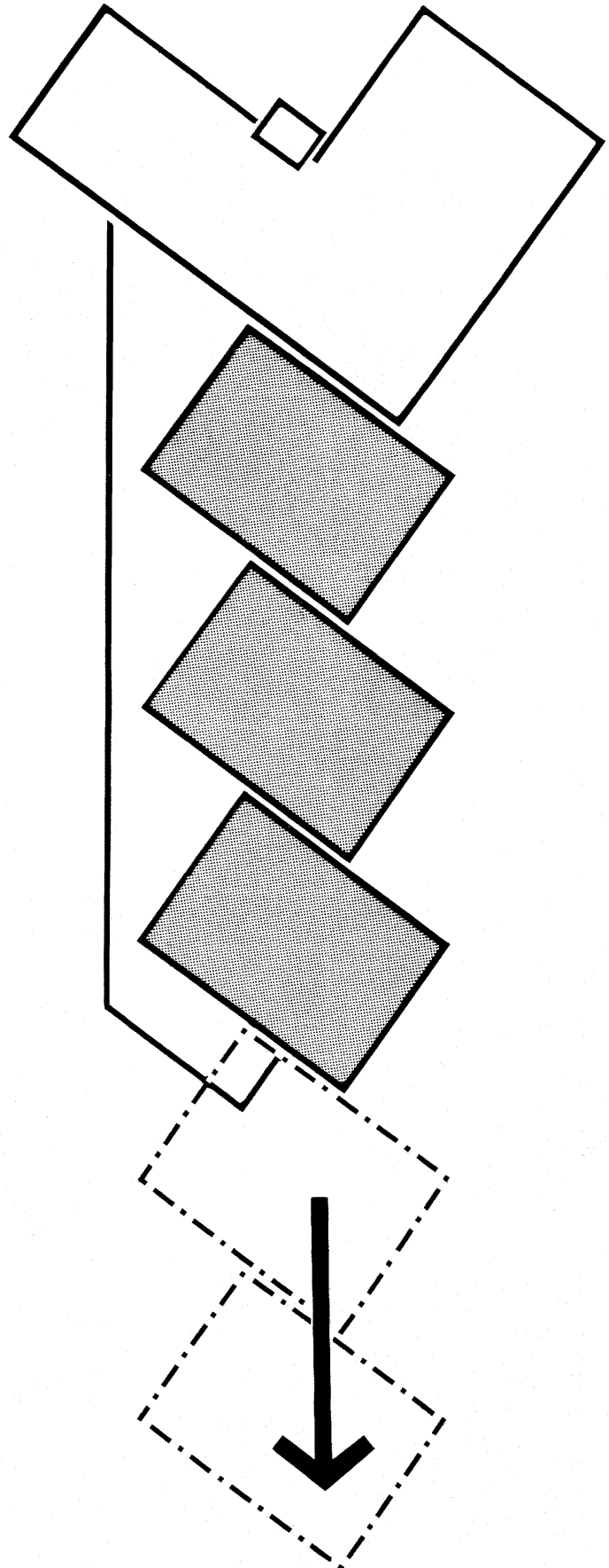

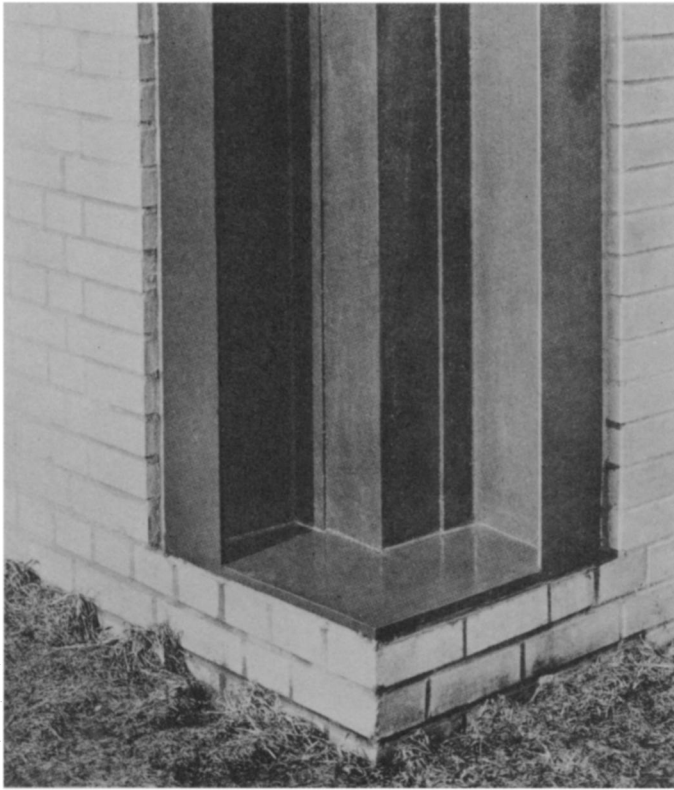

The first public elaboration of the theory of endlessness in England by Richard Llewelyn-Davies was based upon a small and simple object: the corner detail of the Alumni Memorial Hall at the Illinois Institute of Technology by Mies van der Rohe. The two courses of brickwork below the steel emphasize that in the corner detail proper there is no corner, the two wall-planes do not meet, and according to the theory, each thus permits the other to extend to infinity.

the lecture (courtesy of Sir Leslie) was the aesthetic interpretation of the architecture of Mies van der Rohe at the Illinois Institute of Technology campus, Chicago.

Discussing in his text the Alumni Memorial Hall, Llewelyn Davies said: *"The elevations consist all of similar units repeated a number of times . . . No single element is treated as self-contained, nor is it isolated from the rest by special treatment. The part is subservient to the whole. The whole, again, is left unbounded. There are no stop-ends, nor any dominating feature limiting the extension of any particular plane, or concentrating interest at any point in the plane. I think that a wall is conceived by van der Rohe as a portion cut from a plane, extending infinitely into space, and that this quality, which could be called endlessness, is at the bottom of this approach to design. The detail at the corner of the building . . . bears out this point . . . This corner goes unnoticed when we look at the building as a whole. It is the very opposite of the emphasized rusticated corner of the Renaissance, and is almost refined into non-existence. By stepping it back behind the wall faces, by breaking the angle up into numerous angles and planes, the corner has been dissolved away. Thus, and this is the real reason for doing it, the continuity of both walls is preserved. Neither is allowed to pass beyond the other so as to stop its imaginary infinite prolongation."*

It was Llewelyn Davies' misfortune to launch these ideas on an audience that was becoming increasingly sophisticated in historical matters, and within three or four years such arguments were no longer convincing. A generation of younger architects, post-war trained, had grown up who knew too much about the neo-classical tradition to see Mies' facades at the Illinois Institute of Technology as anything but closed classical compositions, and their black steel corners as more visually positive end-stops than any rusticated Renaissance corner. An older generation rejected these arguments on different grounds; like many of the Left in Europe at that time it rejected everything that had to do with America and/or technology as "inhuman."

And yet the idea did not fall entirely flat. You can't go on rejecting technology forever, and because Mies van der Rohe's welded steel architecture has always been regarded as the acme of technological building in Britain, the concept of an endless architecture kept on cropping up whenever advanced building technologies were being discussed. Such technologies are normally visualized by Europeans (including Britons) as being primarily concerned with the mass production of structural elements, and mass production is equally normally visualized, not as a Detroit range of interchangeable options (e.g., Chevrolet with a choice of seventeen bodies and five different engines) but as the relentless repetition of an invariable product. At least this

When indeterminate and endless architecture finally began to be built in England, it bore no relation to its spiritual forefathers. The coarse concrete detailing of the famous Park Hill housing developments by Jack Lynn and Ivor Smith at Sheffield could hardly be less Mies-like, while the plan, shown here in simplified form, emphasizes even more the break-away from “centristic” conceptions. It has five ends (one of them in the middle) and the only unifying factor in the plan is the system of pedestrian walkways that thread through the vast building for nearly three-quarters of a mile (shown in black), while the main facade constantly changes from one side of the building to the other.

was, and still is, the way of seeing the situation in architectural circles, and an endlessly repeated aesthetic seemed thus entirely appropriate to it.

The result could, for instance, look like Emile Aillaud’s seemingly endless, non-centristic, indeterminate snake-plan blocks of flats at Pantin or Bobigny, outside Paris; or the equally indeterminate and extensible architecture envisaged by the Smithsons and others in Britain for their entries for housing competitions in the early 1950’s, and finally realized in the famous Park-Hill housing at Sheffield, by Jack Lynn and Ivor Smith, where the loops and bifurcations of the enormous apartment block produced a non-centristic plan that looks on paper like some crazy, rough-carpentered, man-made chromosome. What was at stake in all these projects, concepts and the rare completed buildings, was an architecture whose form was not defined by the accepted rules of architecture—symmetry, unity, coherence, balance and all those.

Somewhere in the background another concept had floated into the argument unnoticed—the informal or even a-formal order of the composition of action paintings. This idea was, I suspect, brought into the argument by Philip Johnson in 1951 when, in a talk about something quite different at the Royal Institute of British Architects, he interpolated a description of how to live with a Jackson Pollock painting,

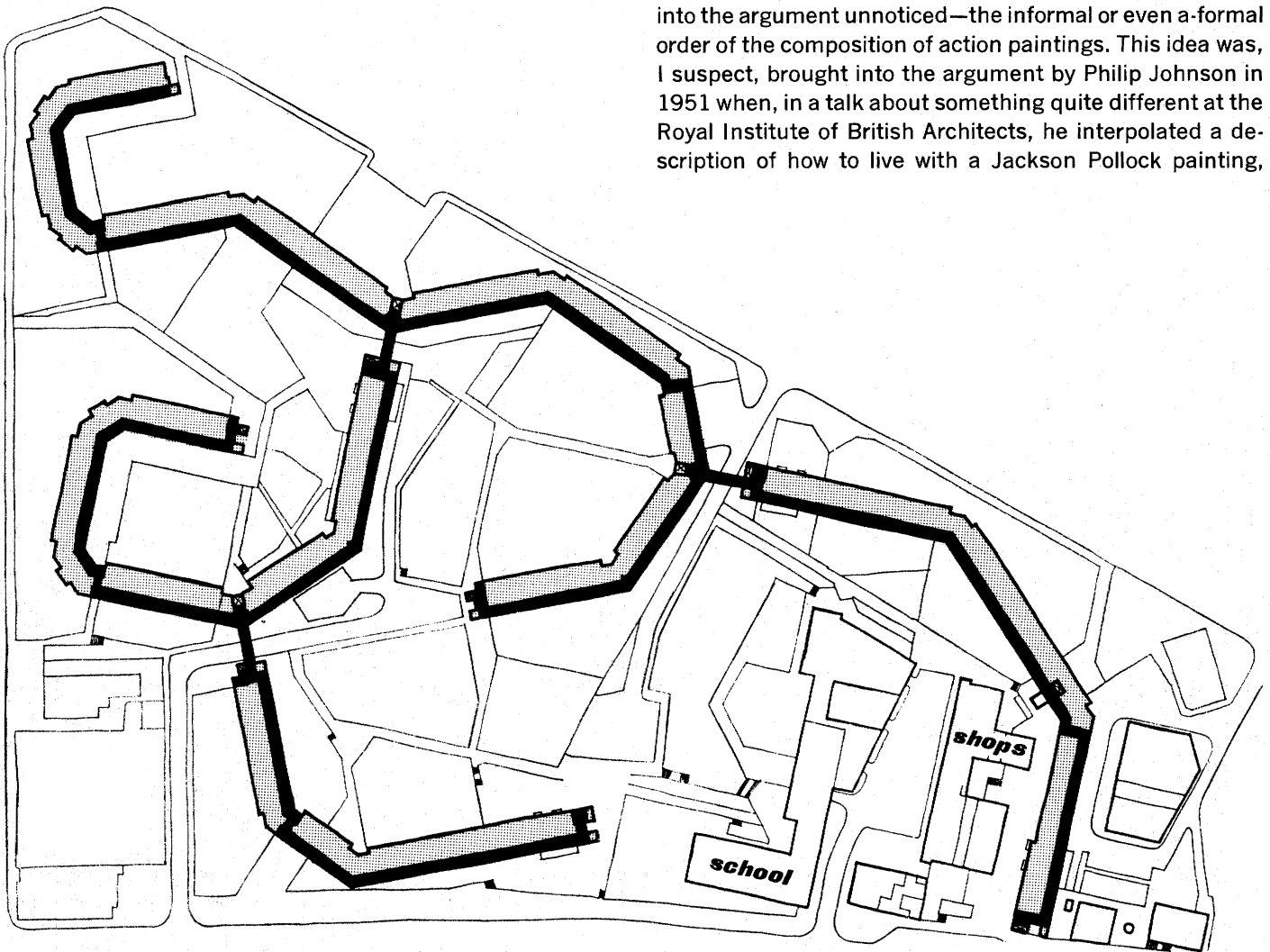

where any one bit of the picture is as good and as important as any other. Curiously enough, the term “Action Architecture” was coined, somewhat later, by Gerhard Kallman—but he did not really mean by this anything more than that the architecture of the Brutalist period had raggedy surfaces and eschewed high finish. But what was germinating in the back of the mind of British architects was a kind of building design which was not only endless, indeterminate and a-formal, but in which every bit was as good as another and could be replaced by any other. This, in a sense, is true of a building made of bricks—any brick is as good as any other brick, and interchangeable. But what the British were beginning to have in mind was a rather larger brick—large enough to live in. The breakthrough toward an endless architecture of indeterminate form was to come by way of very precisely determined units of habitation, clipped together.

A Cell with Services

Alison and Peter Smithson, innovators of so many things in the British architecture of the fifties, produced late in 1955 (for exhibition the subsequent year) a design for a plastic “House of the Future.” It was a seasonable commission—lonel Schein produced one at the same period for the *Exposition des Arts Menagers* in Paris, and Monsanto’s plastic house, which later found a home at Disneyland, is of the same vintage. The Smithson version, however, was more sophisticated than the others in a number of ways. Conceived in terms of a mass-produced product of the 1980’s, it attempted to face the practicalities of mass-marketing by exhibiting something like an architectural version of Detroit styling, and an approximation to Detroit production engineering in that it consisted of a number of large, non-repeating components. Like the fenders or hood of a car they occurred only once in each assembled product (unlike the components of the endless designs discussed above) and the attainment of an economical production run would have depended on the production of a great number of house units. Now, although each house was to be a self-

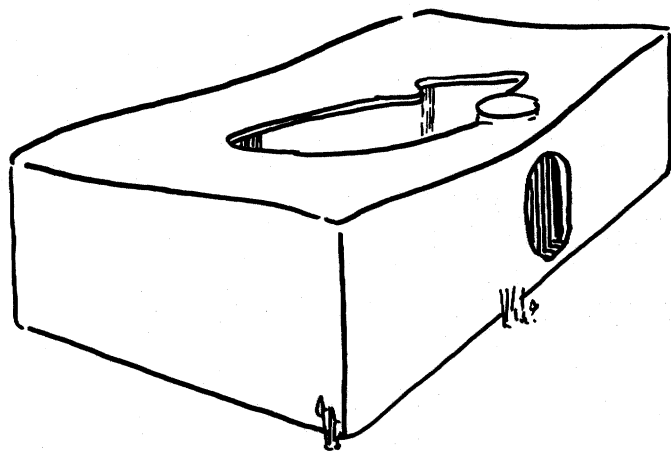

The “House of the Future” project by Alison and Peter Smithson was for a plastic prefabricated dwelling with no openings in the outer wall except the single door—daylight entered the rooms from a free-form patio and the ceiling heights varied according to different lighting requirements. Implicit in the patio-and-single-door conception was the possibility of packing the houses together into double-file superblocks that give high residential densities at single-story heights (see sketch below).

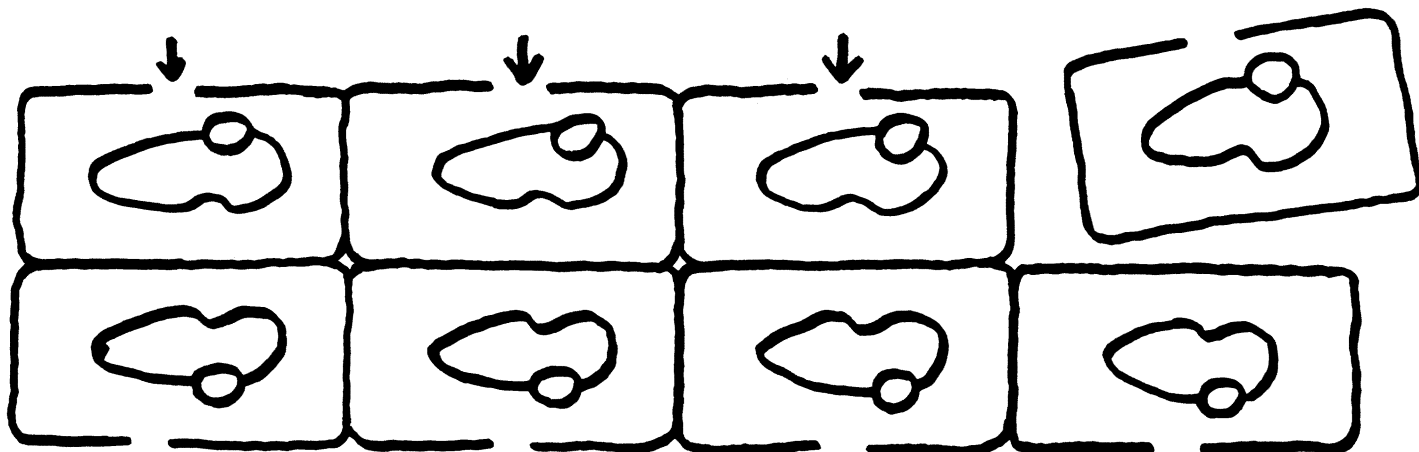

contained unit in itself, stuffed with Futurist household gadgetry, the project did involve an alternative form of endlessness or indeterminacy. All the rooms were to be lighted from an oval patio in the middle of the house, and the only opening in the external walls was for the door on one of the long sides. With three blank walls, the houses could be pushed together into endless rows, two deep, back to back.

This town-planning proposition was part of the design from the start. In this the Smithson "House of the Future" differed from other standard-of-living machines like Fuller's "Dymaxion House," or Schein's "Maison Plastique," which were virtually impossible to assemble into larger wholes; but, like them, it was a fully-serviced dwelling unit, complete and self-sufficient. In this, it differed again from the repeating units of the Llewelyn Davies concept of endless architecture. Where Davies had identified repeating structural units that could be added up into a usable volume, the Smithsons were offering usable volumes that could be added up into something more complex. The concept was less intellectually pellucid, but emotionally more appealing—it is difficult to identify oneself with a pair of vertical mullions, an underwindow air-conditioner and an area of tinted glass, but easy to identify with a room you can stand up and walk about in.

The Smithsons, in their free-ranging way, went off now on a different architectural tack, but Lonel Schein, with his partner, Jacques Coulon, probed further into the possibilities of the repetitive cell in the remaining years of the fifties, producing a series of projects for habitable units that came to look more and more like industrial designers' products, and less and less like architecture. Their mobile book-exhibition project contained provisions for joining the cells together in such a way that you could walk through; their motel unit took the aesthetic further and added to it so high a degree of servicing that each cell became almost an independent living-capsule, capable of being popped off into orbit. Mobile and transportable, both units had made the psychological and aesthetic break necessary to free

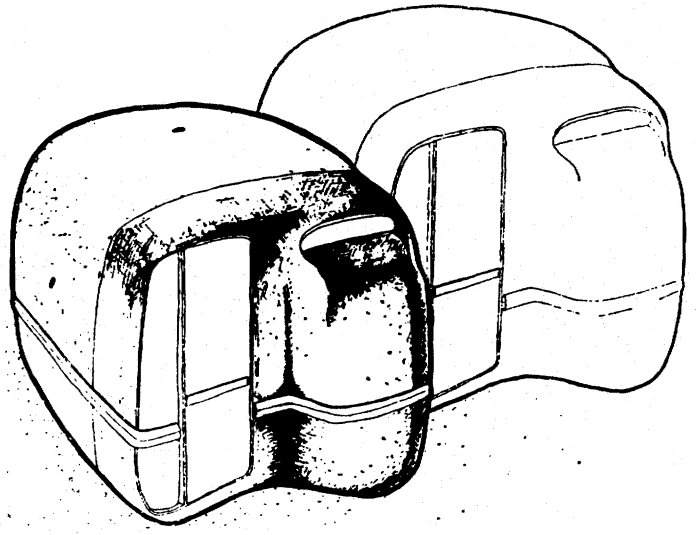

Self-contained plastic prefabricated motel units by Magnant-Coulon-Schein—a project taken to prototype stage in the late 1950's. Special trucks (below) were to deliver these to the site complete and usable once the utility connections had been made. This was probably the first genuine plug-in dwelling capsule.

themselves from architecture's time-honored roots in the ground—Europe, irresolutely and too late, had re-invented the American mobile home, but then immediately went on to offer a further possibility.

Jacques Baudon, a young Belgian architect, interrupted his military service long enough to submit for a competition (in 1959) the design for a house that added an essential further concept—the connector between the units. Apart from the living room, which was of totally indeterminate form and construction according to the whim of the inhabitants, each other function—bedroom, bathroom, kitchen—was housed in a separate capsule reached from a corridor-tube made up of standard branching sections; by adding more sections you could provide clip-on points for more functional capsules, and create a house of any size.

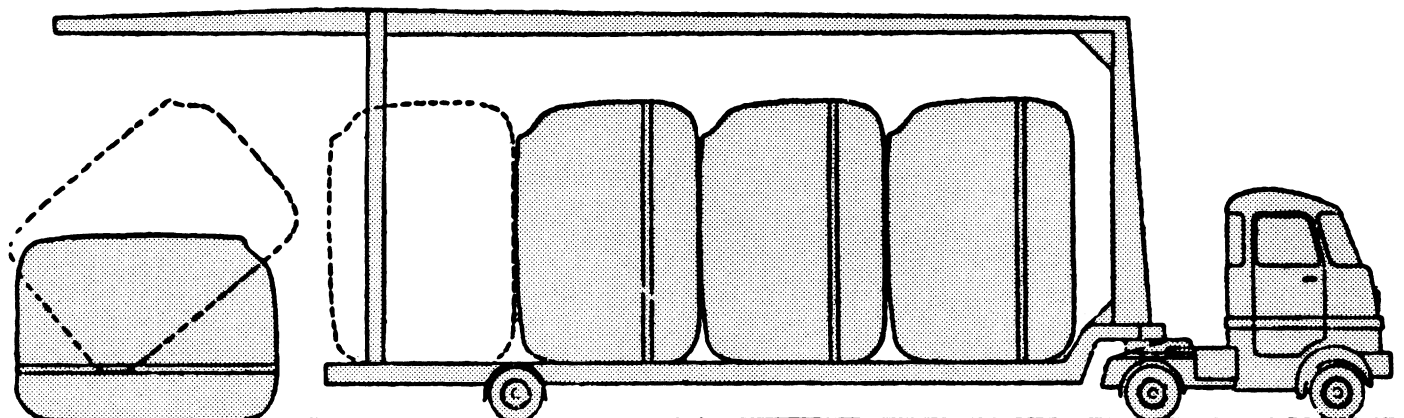

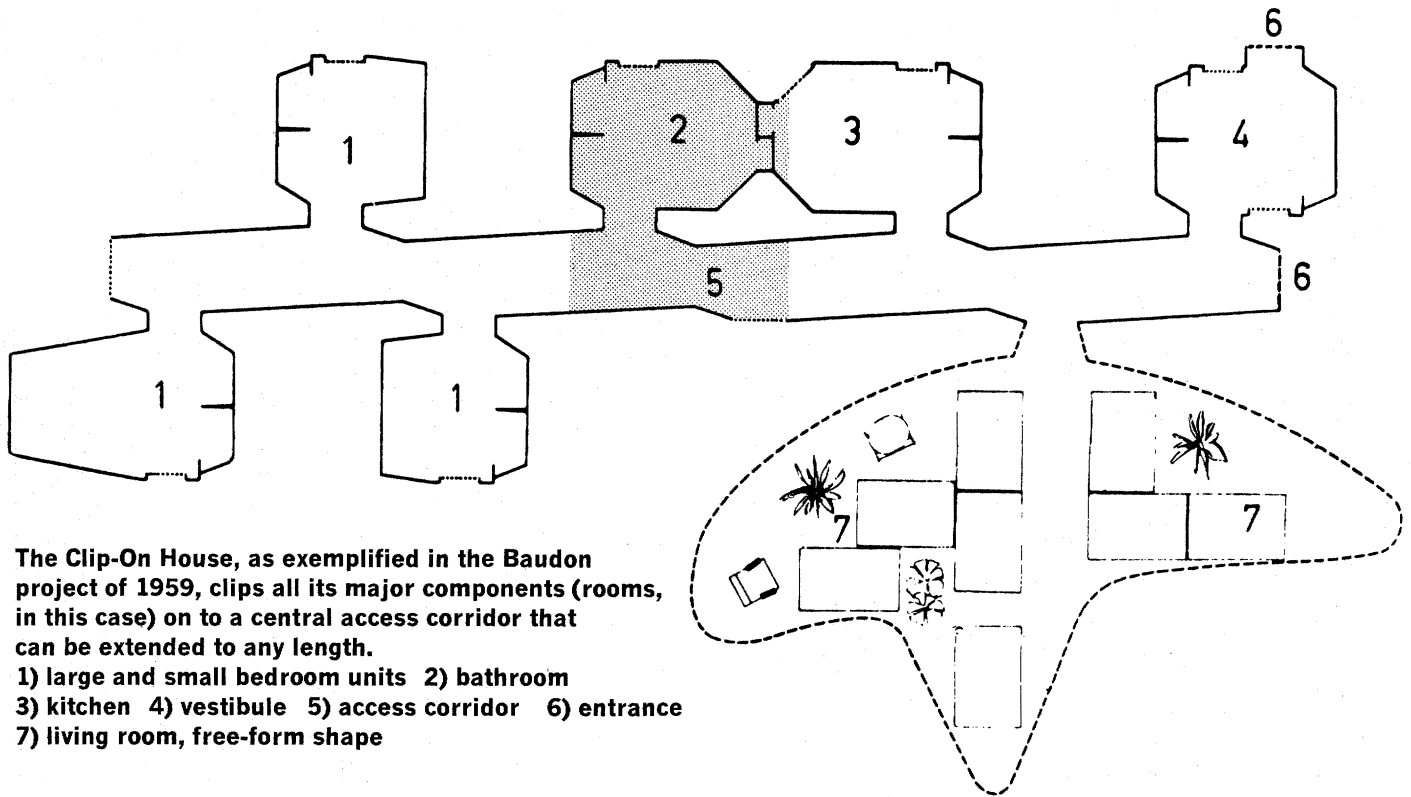

The Clip-On House, as exemplified in the Baudon project of 1959, clips all its major components (rooms, in this case) on to a central access corridor that can be extended to any length.
 1) large and small bedroom units 2) bathroom
 3) kitchen 4) vestibule 5) access corridor 6) entrance
 7) living room, free-form shape

Below: Detailed plan of the bathroom unit, with all its "wet" equipment built into the side that backs up to the "wet" area of the kitchen unit, 3).

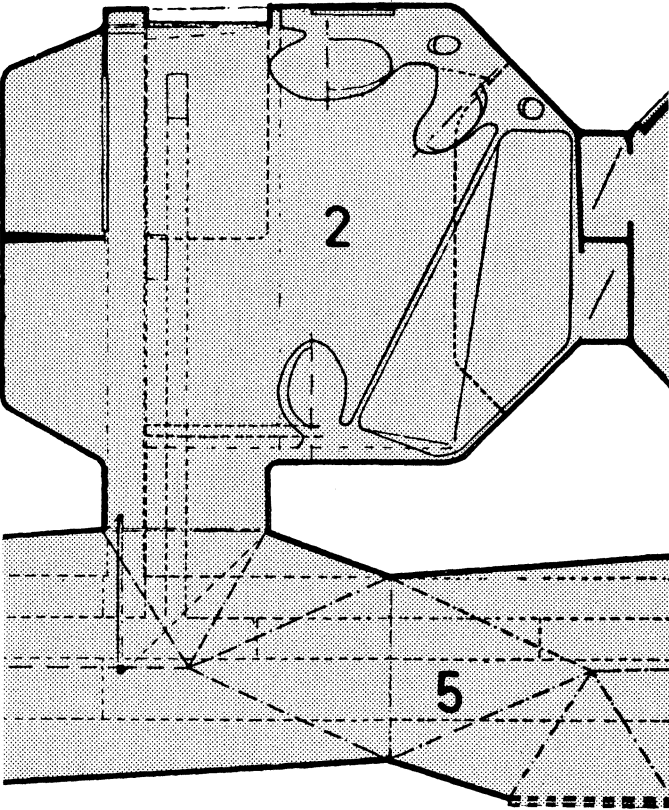

The Clip-On Concept

It was at about this point in time that I first remember using the phrase "clip-on" in connection with architecture. It must have been in circulation for at least a year before I used it in print in the *Architectural Review* in February, 1960, and its meaning was to some extent fixed by conversational usage before then. The sort of ideas that belonged to the concept at that time I can now best reconstruct from some notes for an unpublished article on the clip-on philosophy which were written down in 1961. The epitome of the clip-on concept, at that time, was the outboard motor, whose consequences for the theory of design intrigued many of us then, in the following terms: given an Evinrude or a Johnson Seahorse, you can convert practically any floating object into a navigable vessel. A small concentrated package of machinery converts an undifferentiated structure into something having function and purpose. But, equally, the undifferentiated object might be a paper cup full of black coffee, and the clip-on could be the packets of sugar and Pream and the stirring stick which convert it to the particular cup of coffee that suits your taste.

The architectural equivalent of this, at face value, would be Buckminster Fuller's "Mechanical Wing," the trailer full of mechanical goodies that converts any old shack or hole in the ground into a habitable dwelling. Or, to go back to the Baudon project, the tent, dome or plastic bubble that serves as a living room is the undifferentiated structure,

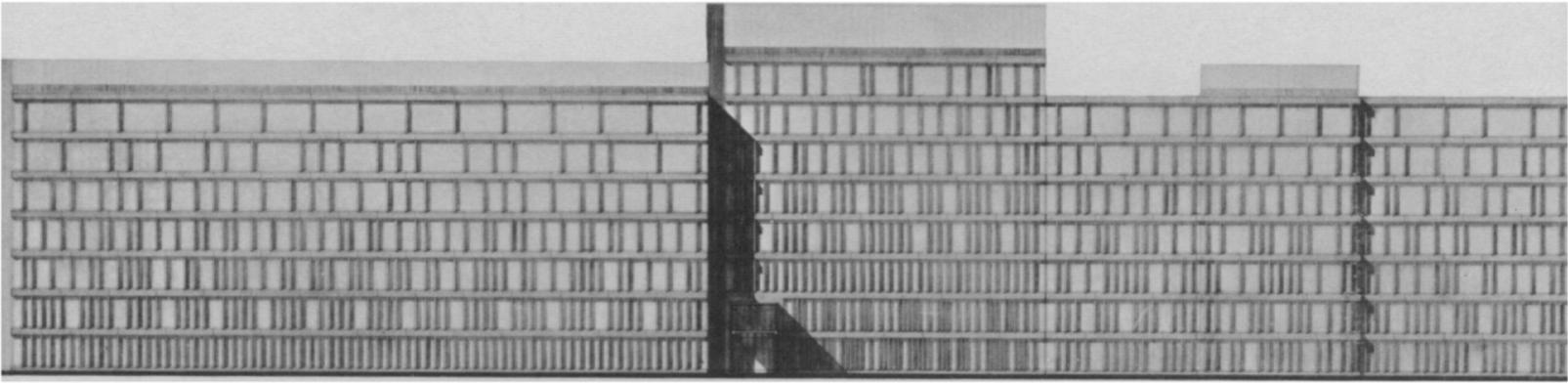

Developed indeterminacy by the inventors of the concept—Northwick Park Hospital by Llewelyn Davies and John Weeks, with structural uprights in the facade distributed according to the loads to be carried, not according to a determined geometrical pattern.

and all the specialized capsules on their connecting corridor constitute the clip-on. The Smithson House, or the Schein/Coulon motel unit are more in the nature of a clip-together architecture, but as soon as they begin to be clipped together they raise a problem which neatly turns the clip-on concept inside out. When more than “two or three are gathered together” (in the words of the Anglican liturgy) a second factor appears as a necessary correlation of their aggregation. Services, communication and other manifestations of interdependency will have to be consciously designed at the same time as the units themselves,—the result of not doing so can be seen in the overhead jungle of wires and marginal slummery of so many American trailer camps. If the units are simply spread on the ground, then the circulation of men and vehicles among them will become a determinant of the layout—as with the corridors of Baudon’s house, or even the way the Smithson houses stack with their doors outwards, thus fixing the lines of communication along the sides of the super-blocks into which they aggregate. If the units are stacked vertically, then some form of external structure will be needed to take up their cumulative weight; and if any substantial number are to be serviced with water, air, gas, piped music or you-name-it, then those services are going to thicken up into some pretty impressive ducts and trunking-in places.

So you reverse the proposition. The generalized structure becomes the source of power, service and support, and the specialized clip-ons become the habitable units. The out-board analogy has to be replaced by something more like the connection of domestic appliances to the house’s electrical supply—which is why a group of English architects, known as the *Archigram* group, use the term “Plug-In” instead of clip-on for their urban projects. But too much should not be made of this distinction between extreme forms of the two concepts: technically they are often intimately fused in a single project, and the aesthetic tradition

overruns niceties of mechanical discrimination. The aesthetic is still the Clip-On Aesthetic, but multiplied by a wild, swinging Pop Art vision that is a long way from the intellectual austerities of the speculations of Gerhard Kallman or Llewelyn Davies.

So, while the architecture of the Establishment rusticated in the picturesque prefabrication techniques of the tile-hung schools of the CLASP system (Consortium of Local Authorities Special Programme), while British Railways prepared to drop into place the first of their plastic switchgear huts (serviced cells if ever there were any) and Llewelyn Davies and Weeks began to square up to the design of their endless and indeterminate hospital at Northwick Park (where even the repetition of the structural units goes on an indeterminate pattern) . . . while, in short, possibilities of the fifties were being translated into the practicalities of the sixties, younger architects were about to set up new projected possibilities, in which a conscious element of play upon the life-enhancing potentials of the most advanced urban technologies becomes a major animating force.

British Railways (Eastern Region) prototype plastic relay-room (for electric signaling equipment) on site at Thames Haven.



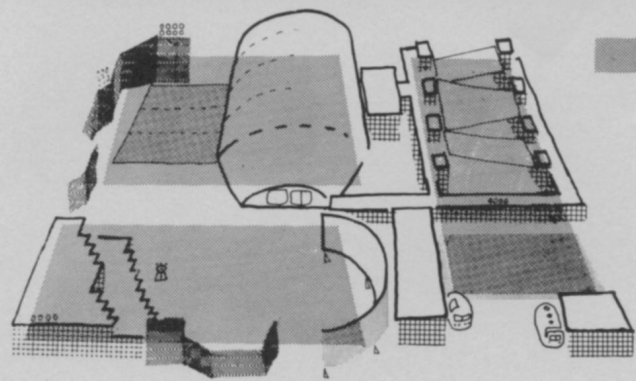

LINKED ACTIVITY ZONES.
Total & partial control combined.

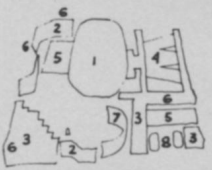
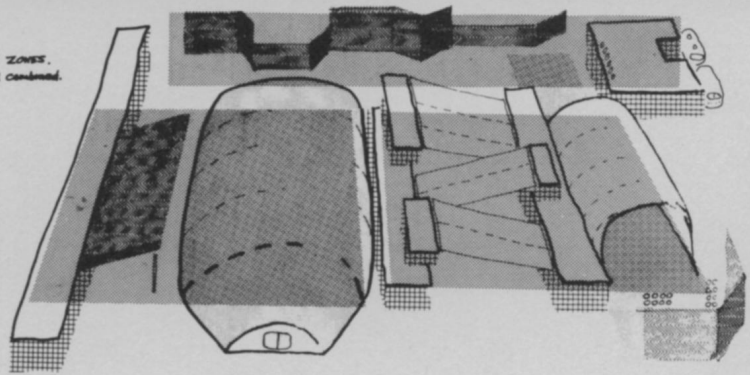

1. LARGE CONTROLLED VOLUMES FOR ASSEMBLY, EXHIBITIONS, ETC.
Inflatable structure. Totally or partially enclosed, open or restaurant. Free area or containing sub-enclosures.
2. EXTERNAL SCREENS PROVIDING ADJUSTABLE LIGHTING, ACOUSTIC & PARTIAL TEMPERATURE CONTROL
Tripartite space-frame (al.) self-supporting, capable of adjustment & M-assembly & containing heat, light & sound reflectors & baffles.
3. VARIOUS ENCLOSURES FORMING ROOMS, GALLERIES, SHELTERS, WALKWAYS, BALCONIES, ETC.
'Box' units with walk floor, stairs, screens etc. Inflatable panels arranged as required.
4. TENT ROOFS & AWNINGS
Placed over main streets.
5. FLOORING FOR PARTICULAR USE e.g. DANCING
Flooring panels direct on soil surface - internal & external.
6. EXTERNAL FLOOD & SPOT LIGHTING
Fillings capable of manual & remote control.
7. EXTERNAL SCREENS FOR FILM & OTHER PROJECTIONS
Weather resistant. Fixed & swivel screen - direct & back projection.
8. MOBILE KITCHEN OR OTHER HIGHLY EQUIPPED CONTAINED SERVICES
Vans & buses with loading jacks.
9. HORIZONTAL OR INCLINED BARRIERS AS 2.
Capable of control by pneumatic jacks.

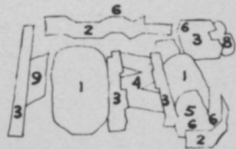

Fun Palace pilot-project: Not a prototype for the structural system of the full-size palace (which would not be needed for a small installation) but a dummy-run for the activities, services and systems in various plan-arrangements. For instance, linked activities in adjacent areas need varying degrees of environmental control—in both arrangements areas labeled 1 are fully controlled, adjacent 5 areas are partially controlled.

Below: Pilot kit arranged for a possible site in Camden Town, London. Open air movie screens for night use (center) and inflatable display hall (left).



A Machine to Live It Up In

And I mean “play.” The Fun Palace project—announced as the First Giant Space Mobile in the World—is a mechanized shrine to *Homo Ludens*, conceived in the first instance by Joan Littlewood, that astounding blend of social conscience and strolling player who put before the world for the first time such theatrical knockouts as *The Quare Fellow*, *The Hostage* and *Oh, What a Lovely War*. Her fanatical belief in spontaneity and audience participation led her to conceive of a place, a zone of total probability in which the possibility of participating in practically everything could be caused to exist, from political rallies to Greco-Roman wrestling, table tennis to choral song, dervish-dancing, model drag-racing or just goofing and falling about, where even the simple business of walking around or finding where to go next would be rewarding or stimulating.

This could doubtless have been achieved by means of a large number of single-purpose buildings in a park of rest and culture, but by the time Joan Littlewood and her team of “younger creative nuts” (as she calls them) finished with the idea, they had a giant erector set, compact enough to fit on a tight urban lot, but big with the potential of manufacturing spaces for all purposes. It is not, however, a large building which can be variously subdivided; it is simply a kit of parts and a space-grid of supports and services which can pick up, assemble and animate the parts to suit whatever purpose comes along, and then put everything back in the box in the morning. The space-grid consists of vertical towers full of works, from toilets to electronics, carrying a system of gantry cranes on their heads to maneuver the parts into position, and with their feet resting in heavy servicing plants (including sewage disposal—since the Fun

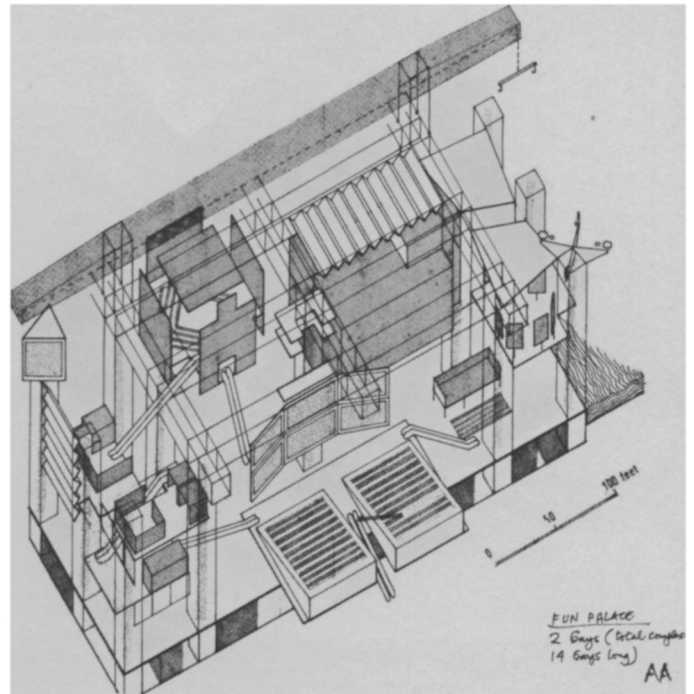
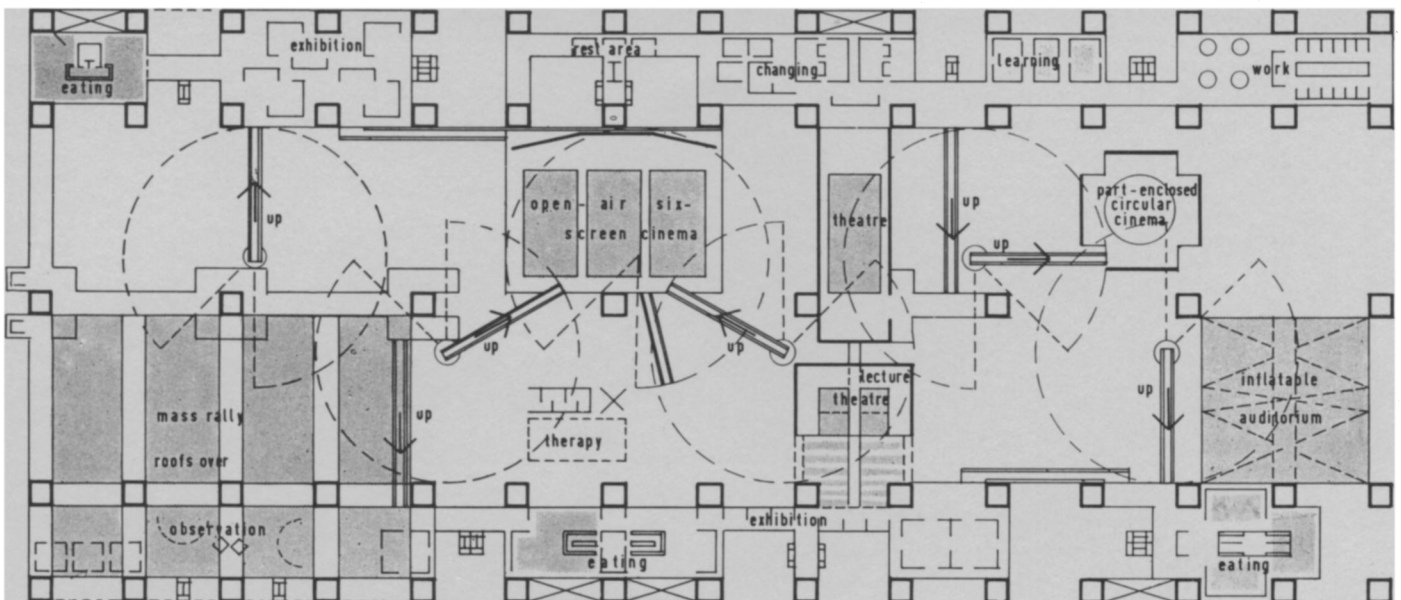
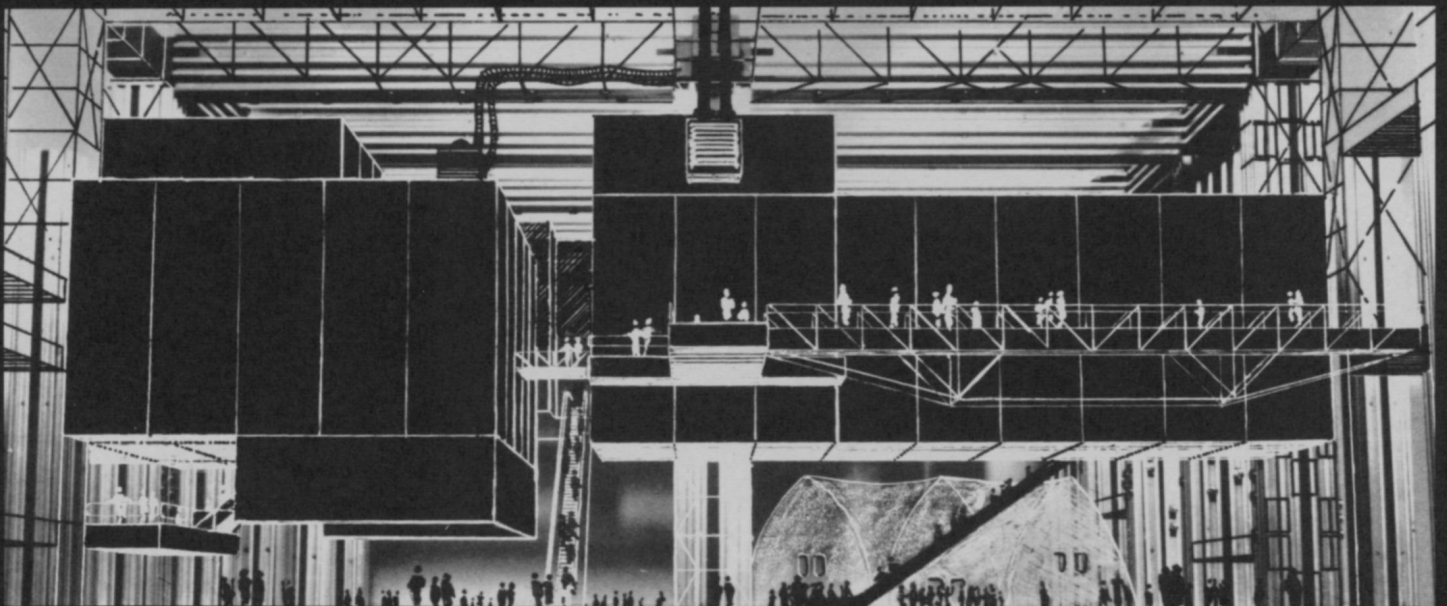
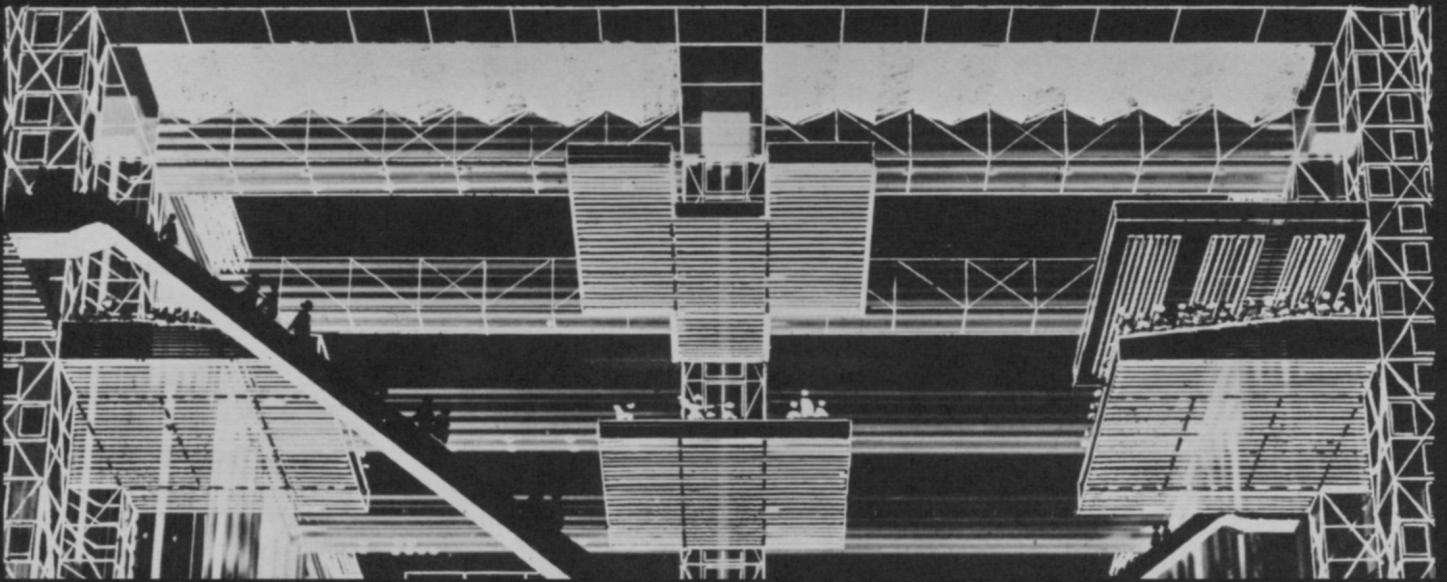
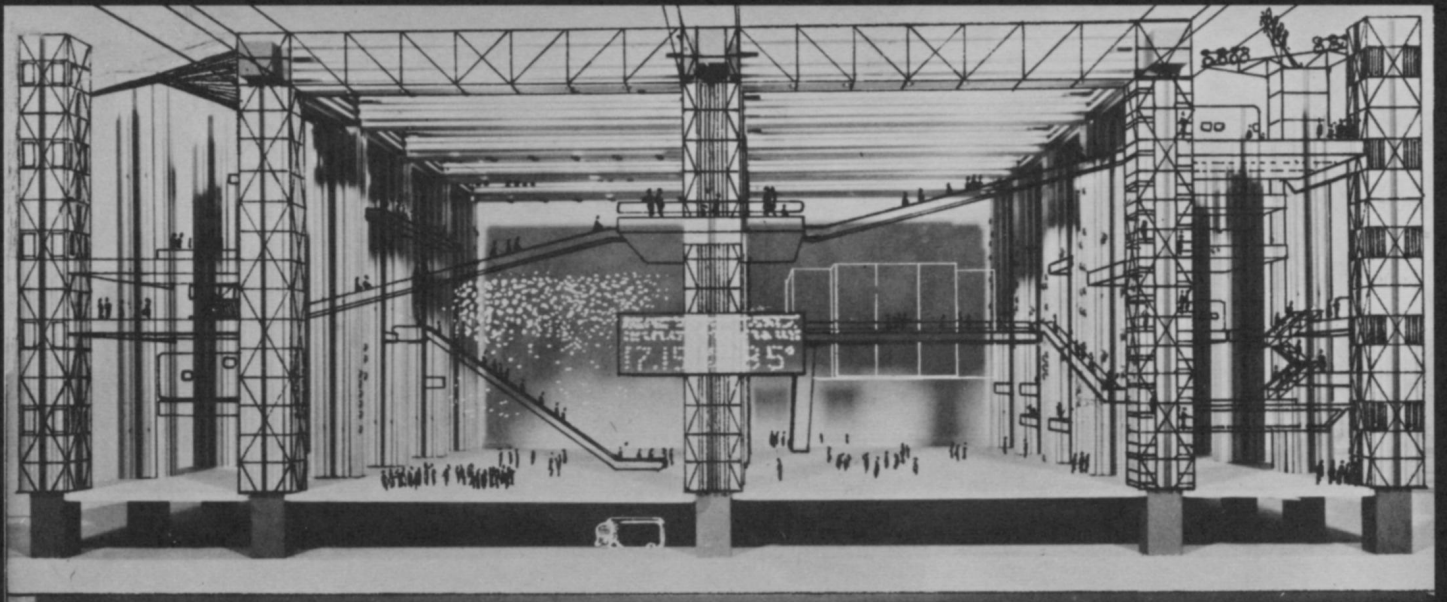
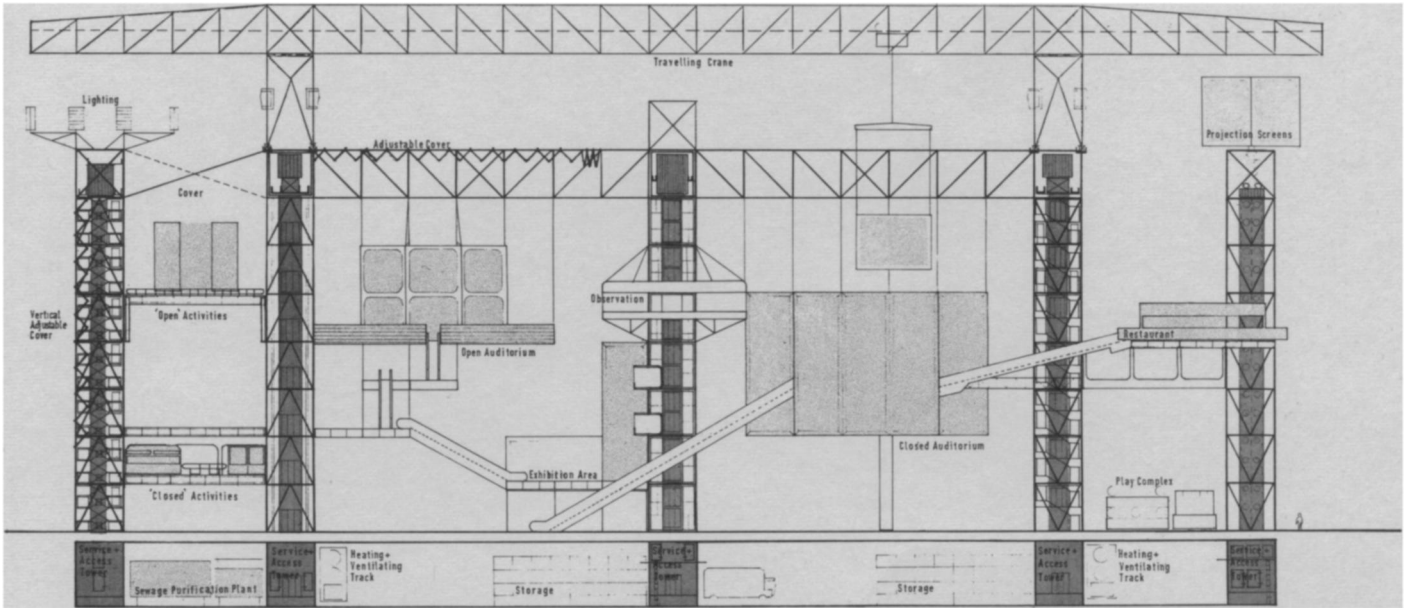

Diagram of two of the fourteen bays which comprise the full-size Fun Palace. Most types of activity space are seen assembled, as well as the gantry-crane with 380-foot travel which is used to assemble them.

Below: Plan of the full fourteen bays; the shaded areas represent ramped seating, programmed circulation through exhibitions or other organized use of floor space. Also to be noted are the circles swept by the pivoting escalators which provide the main circulation between different levels.







Section through an early version of the Fun Palace design: The general principle of suspending the main activity spaces survives in all later versions, but the floor trusses in the side aisles are now less deep and more of the services have been moved to the top of the structure.

Opposite page, top: General view of central space and side aisles; Center: Three-gallery open auditorium with partial environmental controls over seating ramps and folding blinds sheltering open central area; Bottom: Two suspended auditoria with independent conditioning packages and access bridges.

Below: Intensive-use areas located in two bays of the side aisle: snack bar right foreground; exhibition and teaching machine area to the left, and toilet units suspended between towers in the rear.

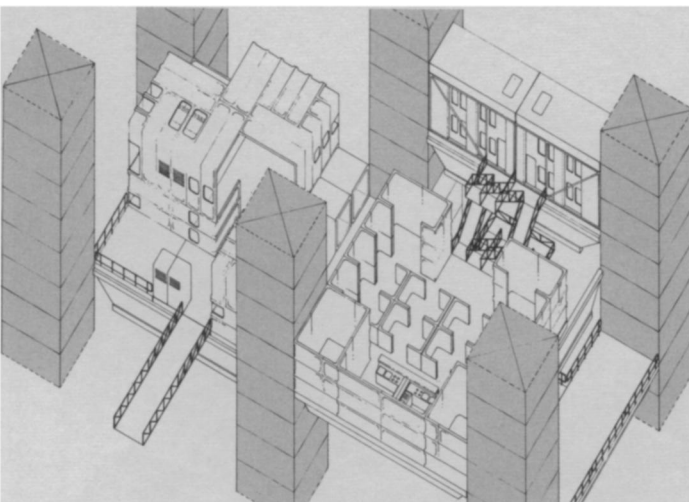

Palace is a piece of ten-year-expendable urban equipment, a degree of detachment from permanent mains services is to everybody's advantage).

Day by day this giant neo-Futurist machine will stir and re-shuffle its movable parts—walls and floors, ramps and walks, steerable escalators, seating and roofing, stages and movie screens, lighting and sound systems—sometimes bursting at the seams with multiple activities, sometimes with only a small part walled in, but with the public poking about the exposed walks and stairs, pressing buttons to make things happen themselves.

This, when it happens (and it is on the cards that it will, somewhere, soon) will be indeterminacy raised to a new power: no permanent monumental interior space or heroic silhouette against the sky will survive for posterity to remember the designers by—Cedric Price (architect), Frank Newby (structural engineer) and Gordon Pask (systems consultant). If it is going to be a monument to anything, it will be a monument to architecture's silent partners, the invisible and long-suffering mechanical servitors who keep most buildings going, but never receive thanks or acknowledgement for it. For the only permanently visible elements of the Fun Palace will be the "life-support" structure on which the transient architecture will be parasitic. It is possible to do this for a single giant "Anti-building," but could it be done for a whole city?

TURE / PLUG-IN CITY / CAPSULE-UNIT TOWER / PLUG-IN UNIVERSITY NODE / TH

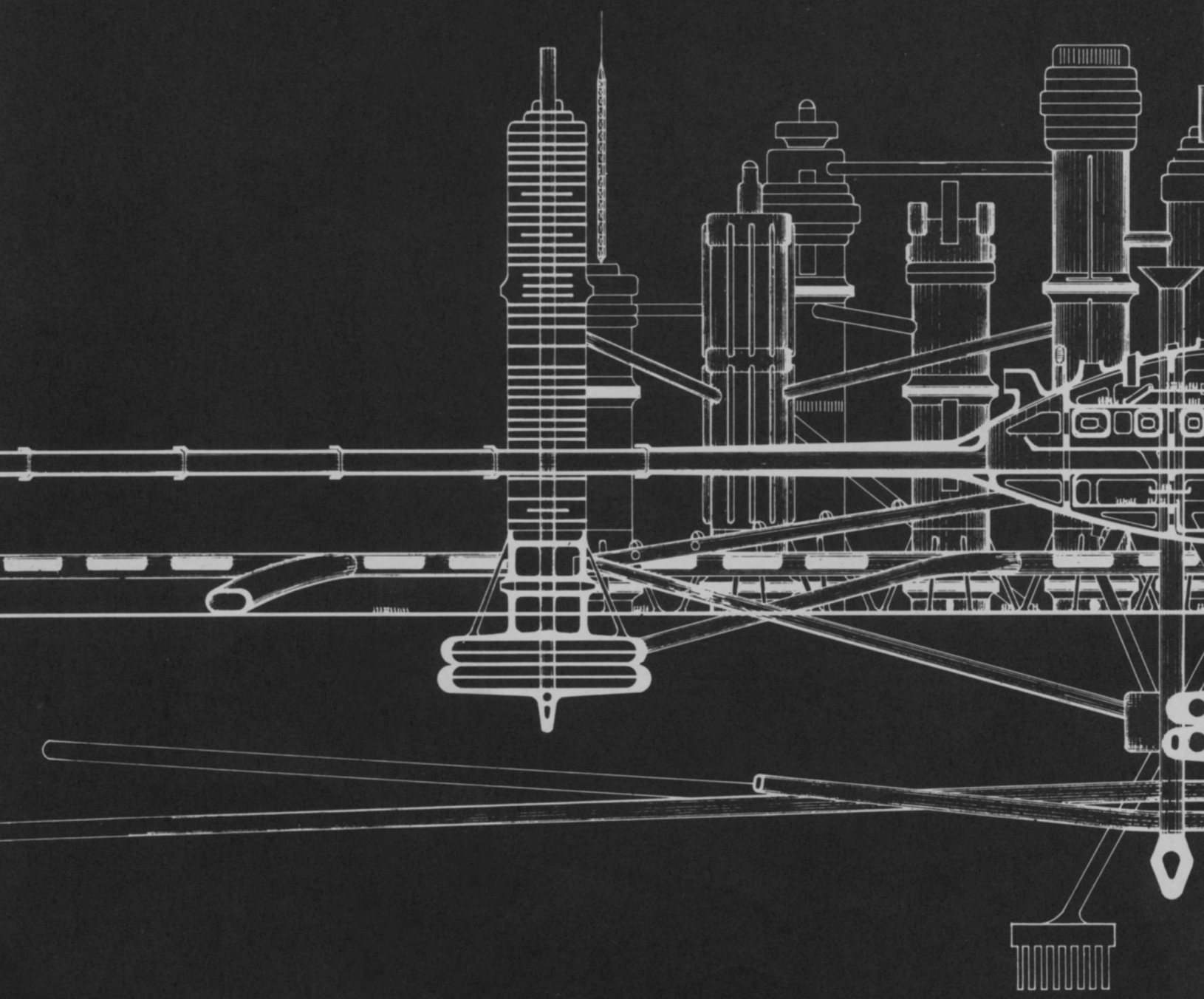

WALKING CITY / ENTERTAINMENT TOWERS / PLUG-IN SVILLE / CLIP-ON ARCHITECTURE

Plug-In City: A magisterial vision of urban connectivity drawn by Ron Herron and Warren Chalk. Heroic infra-structures of this order of complexity provide the basic services for every plug-in project designed by the Archigram group, though few have so obvious a central nucleus as this one.

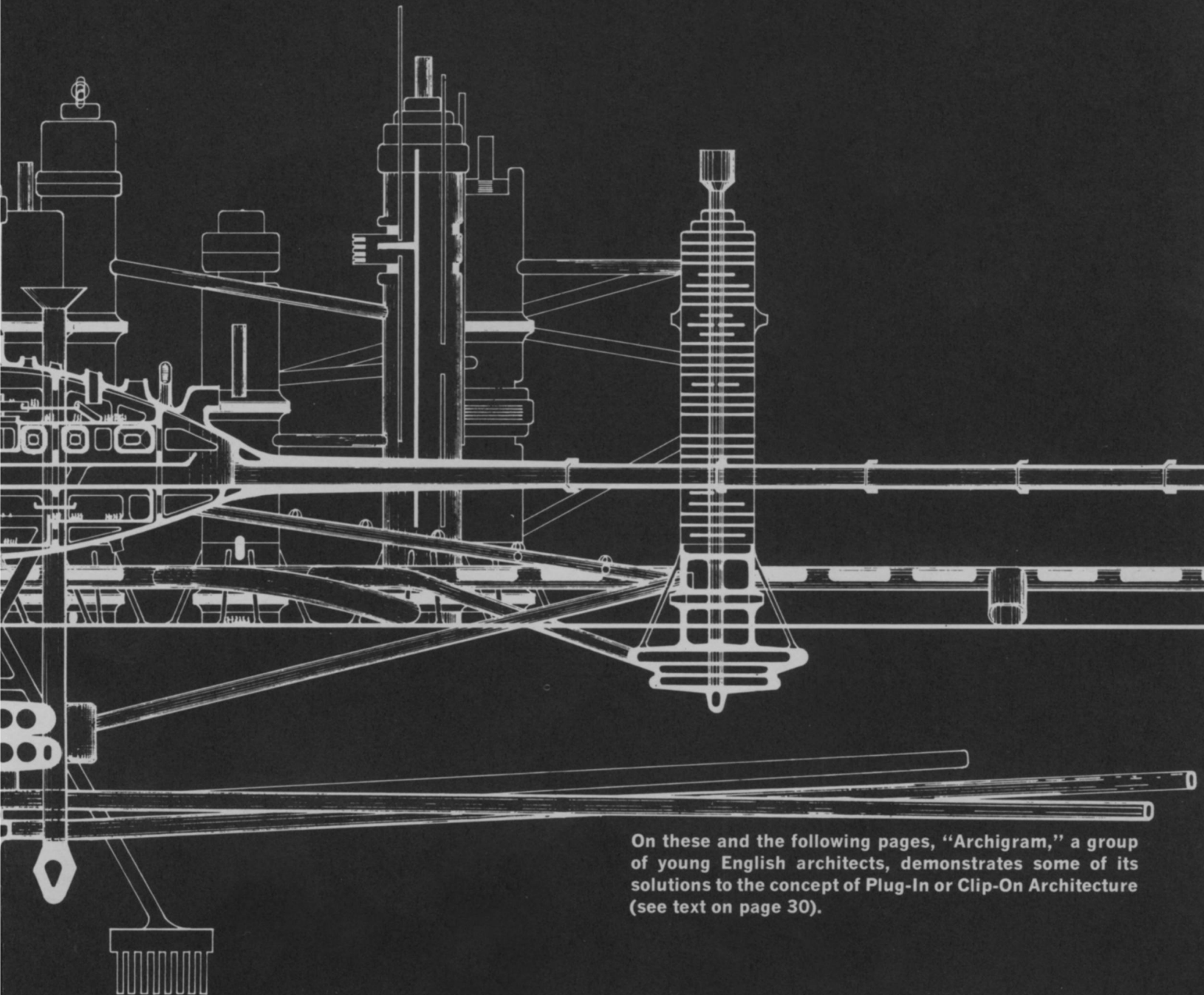

On these and the following pages, "Archigram," a group of young English architects, demonstrates some of its solutions to the concept of Plug-In or Clip-On Architecture (see text on page 30).

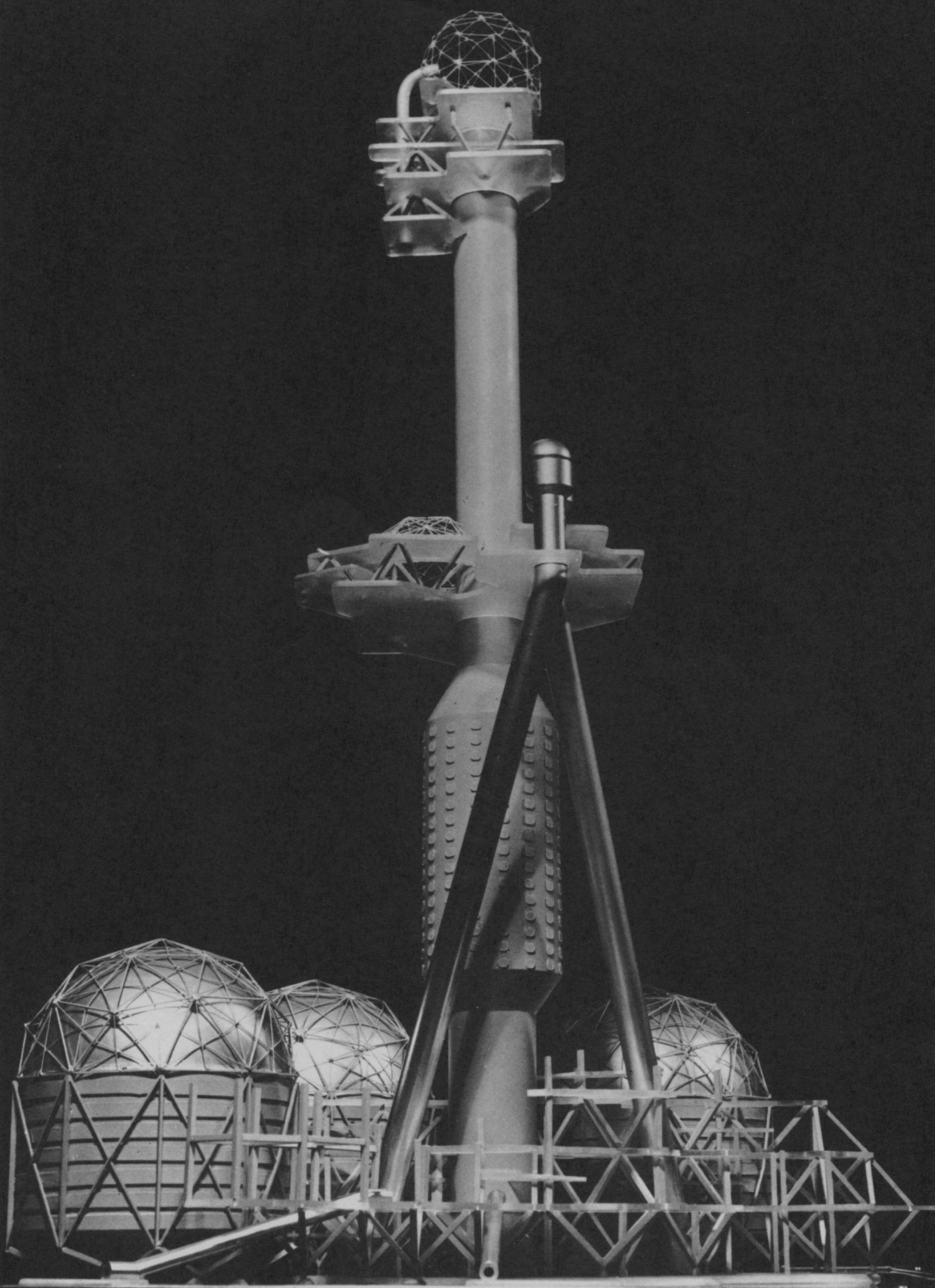

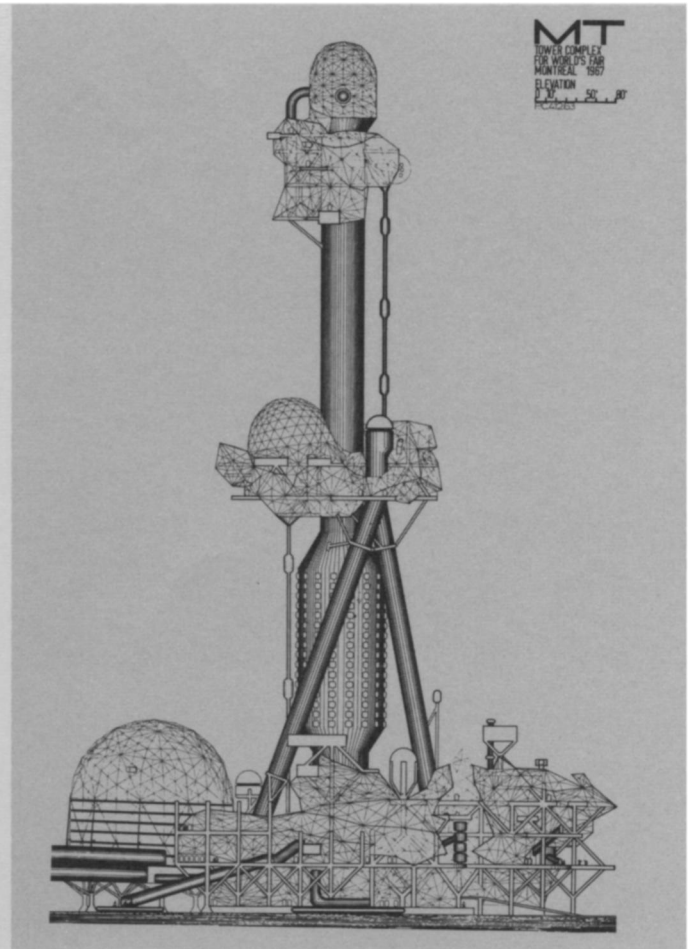
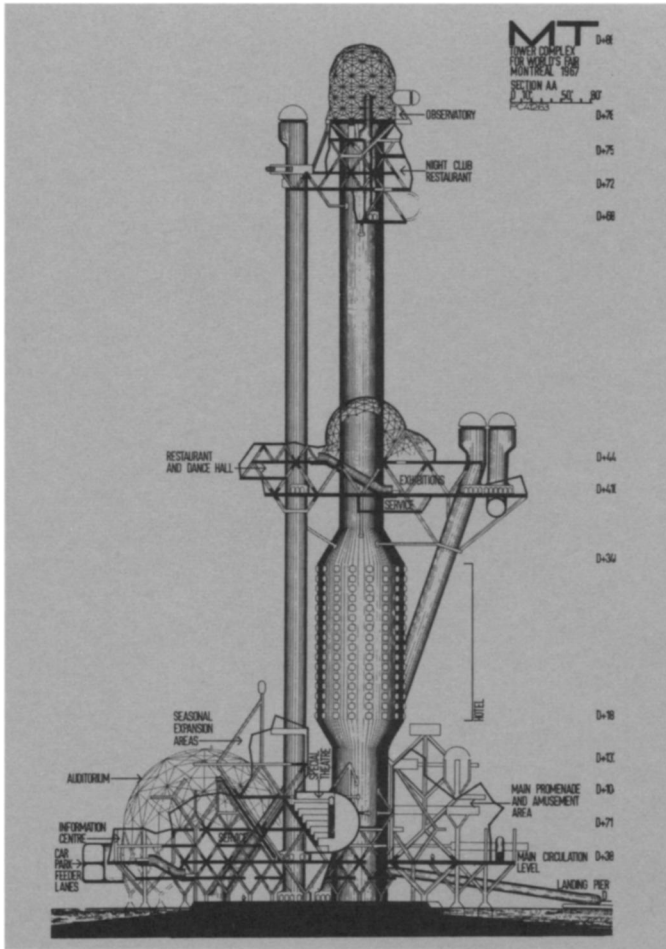

The clip-together aesthetic of the Archigram group came nearest to realization in this project for an entertainment tower, devised by Peter Cook and modeled by Dennis Crompton (left) for the Montreal World's Fair of 1967. The components are to be clipped together and include a number of Buckminster Fuller geodesic domes and a standard prefabricated 800-foot TV tower core projected by an English construction company for export to various parts of the world.

Right: Plan at the level of the auditoria and the main concourse area.

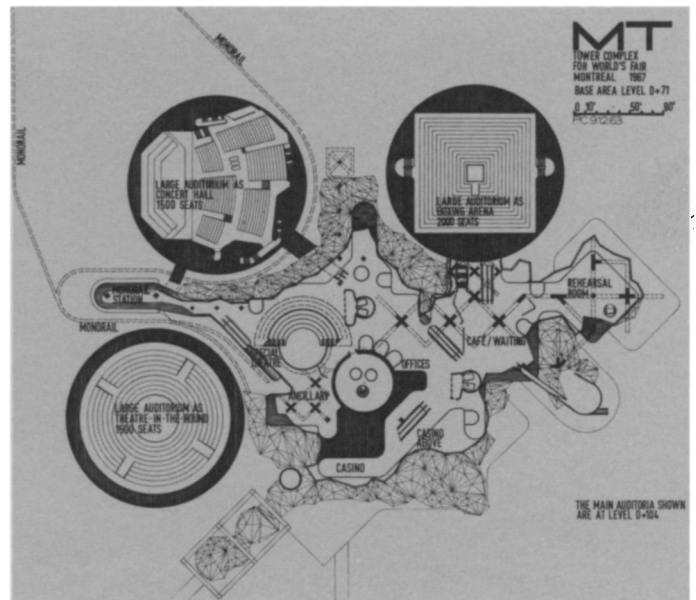

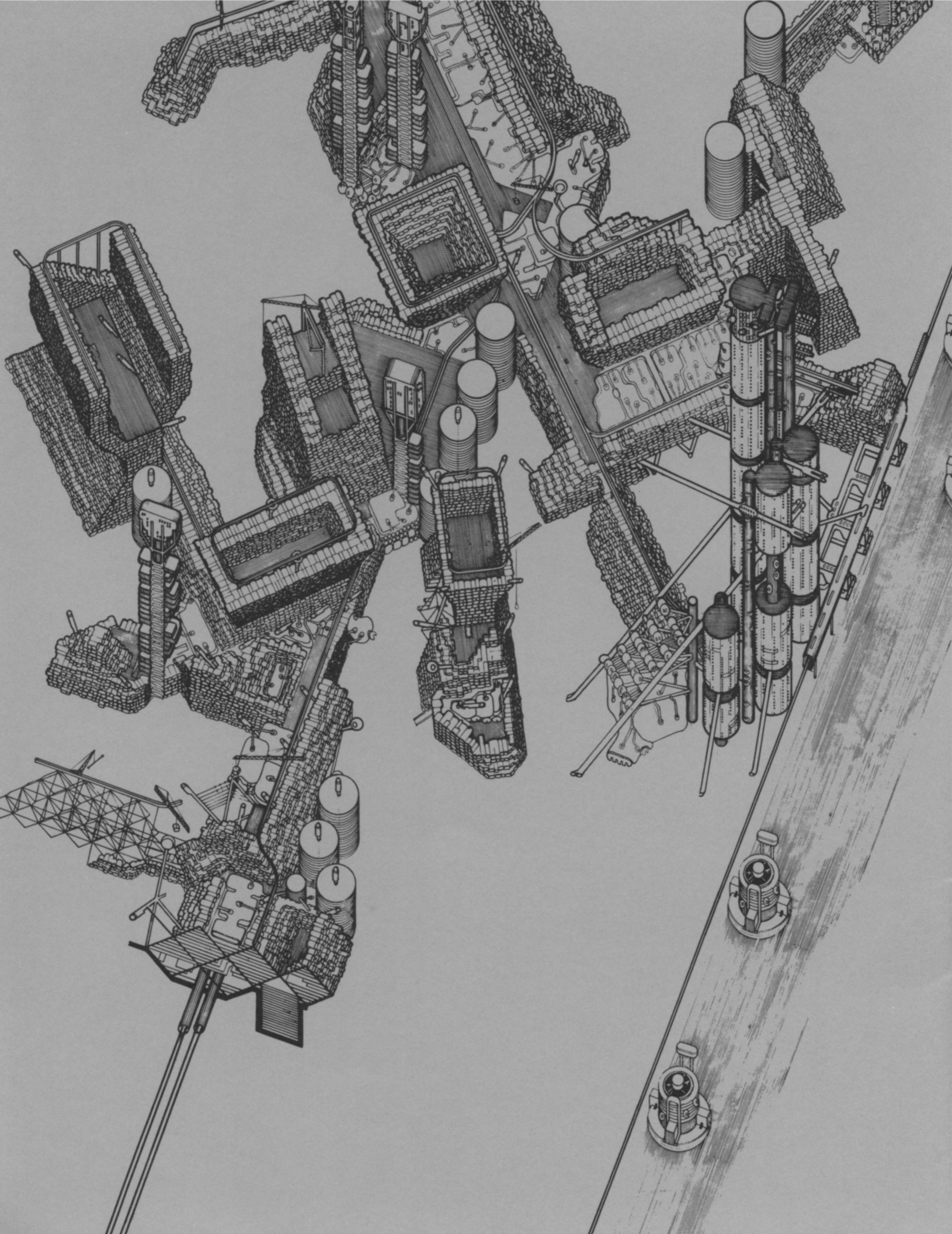

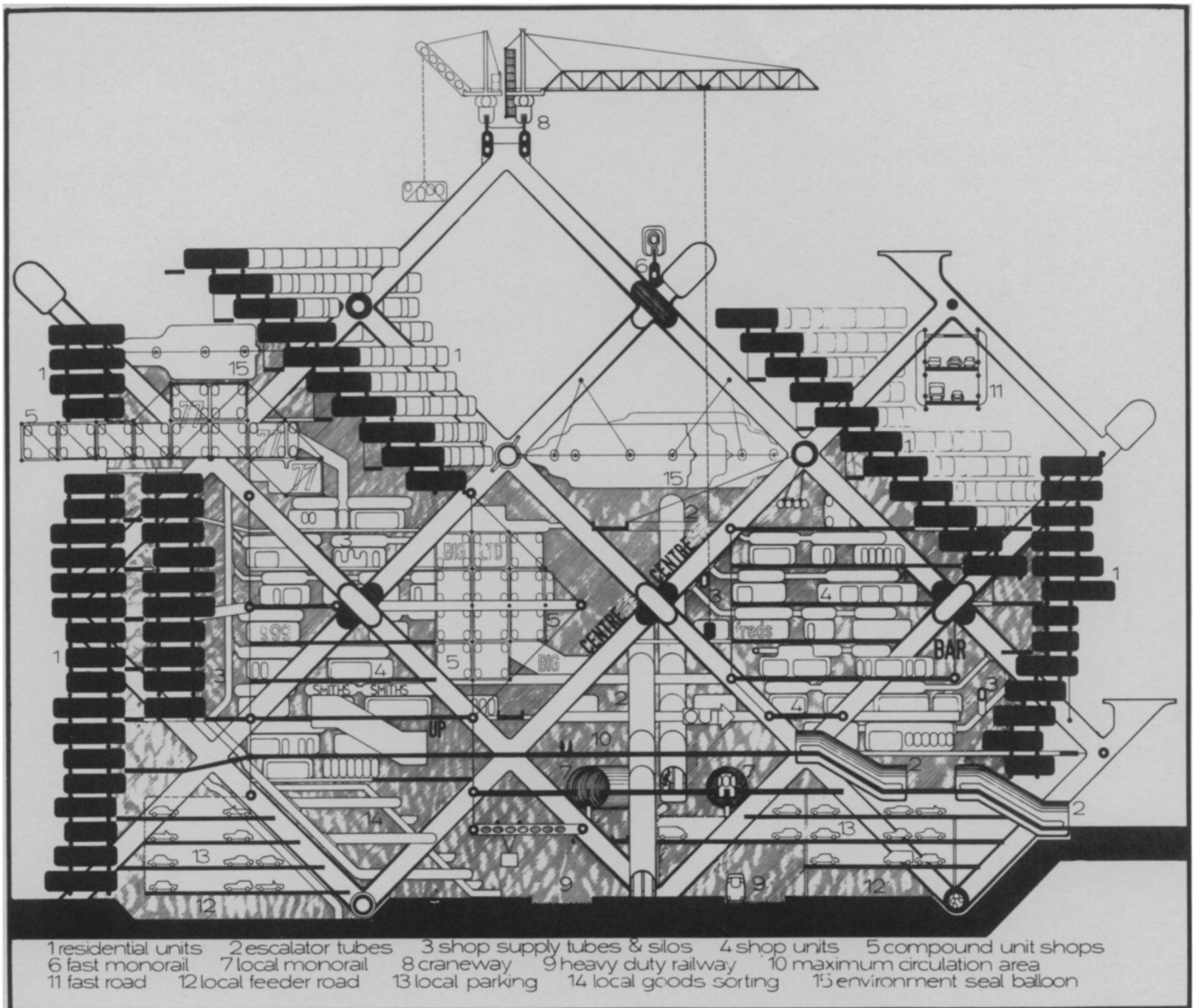

The detailed studies on this page exemplify the essential components of the Plug-In kit: a basic lattice of giant plumbing, serving for both life-support and structural support; cranes to remove, install or service the expendable accommodation capsules. Right: Various types of tower cores to which the capsules can be plugged in to produce different kinds of buildings for business and residence.

Left: The Plug-In City as a complete urban complex. This fully-elaborated view is part of a concentrated study of the implications of the Plug-In concept made by Warren Chalk, Peter Cook and Dennis Crompton in 1964.

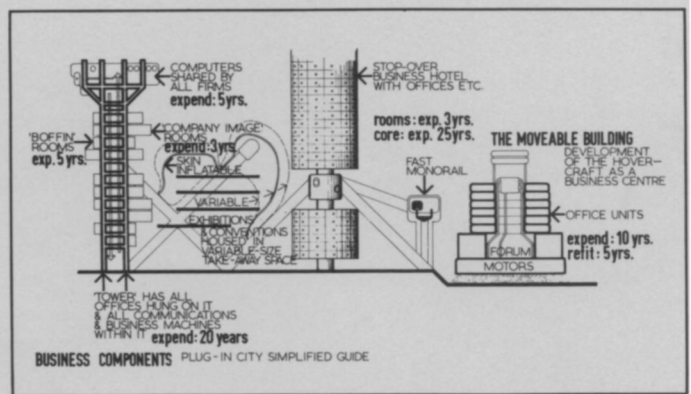

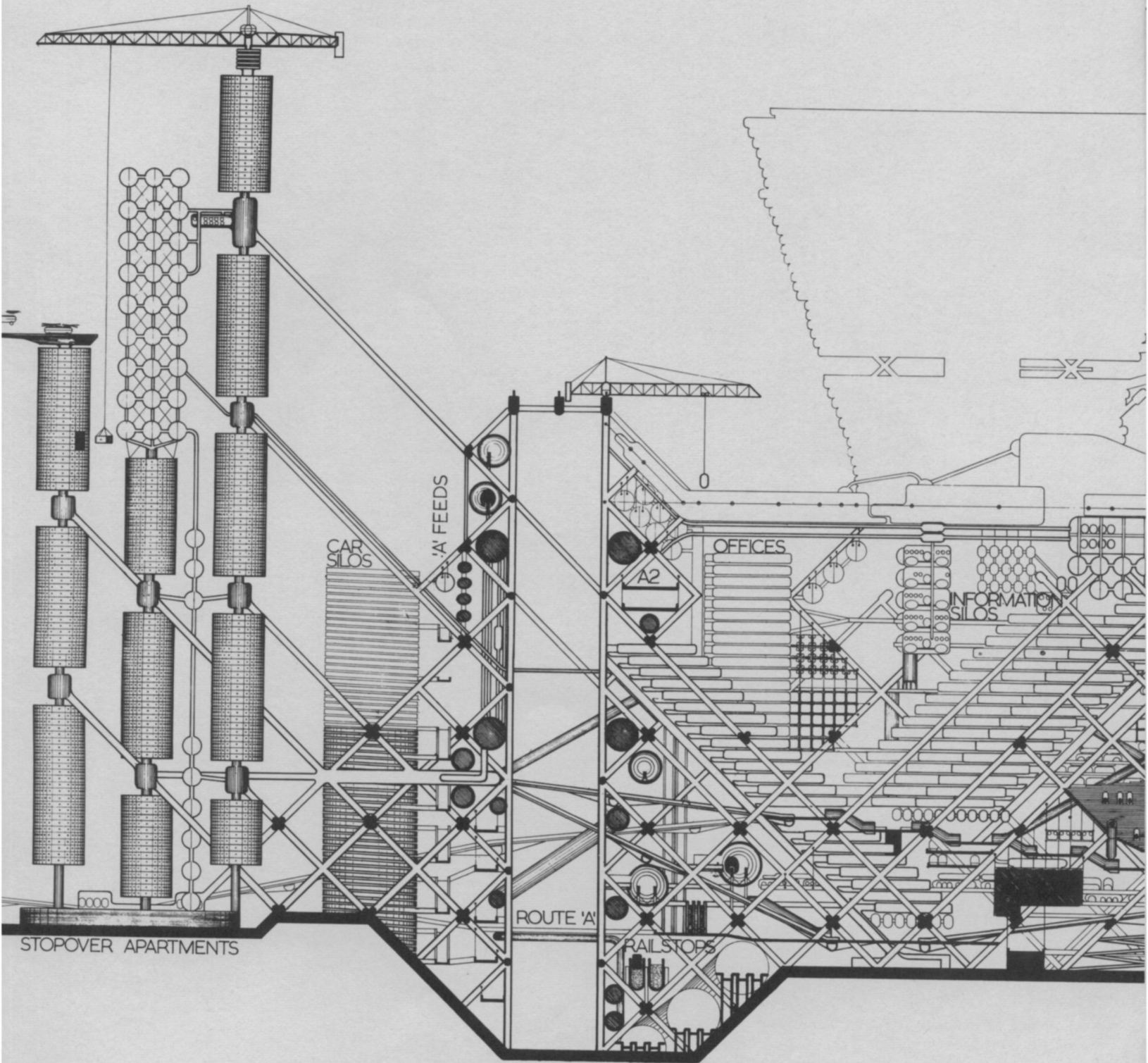

This “maximum pressure” area of Plug-In City corresponds roughly to the downtown area of a conventional centralized city (detailed by Peter Cook). In this case, however, the area can expand laterally along the lines between Route A and Route B. Most of the components of the kit will be recognized from previous pages, but note also the main trunk arteries A2 and B1 suspended high up in the structural lattice.

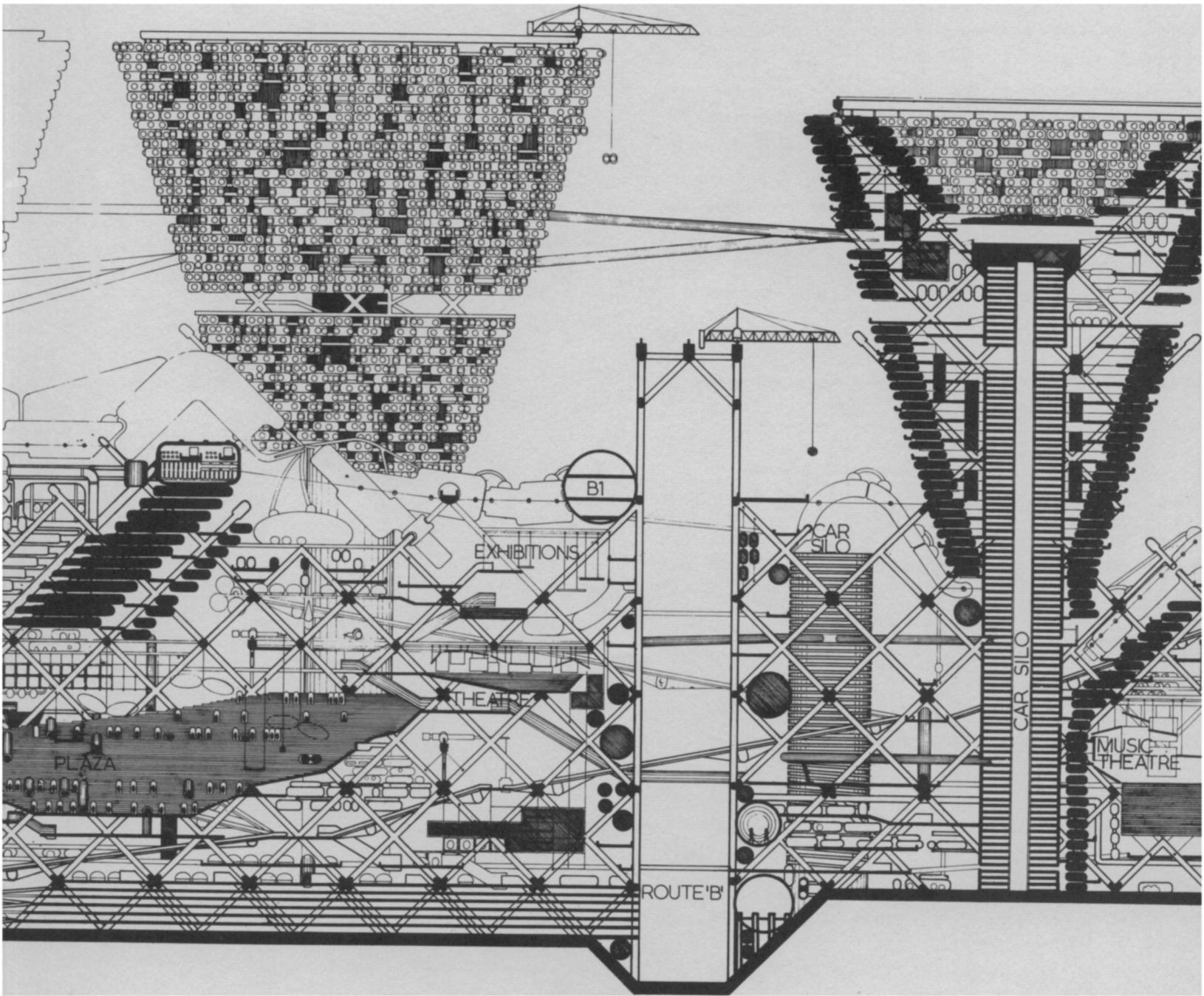

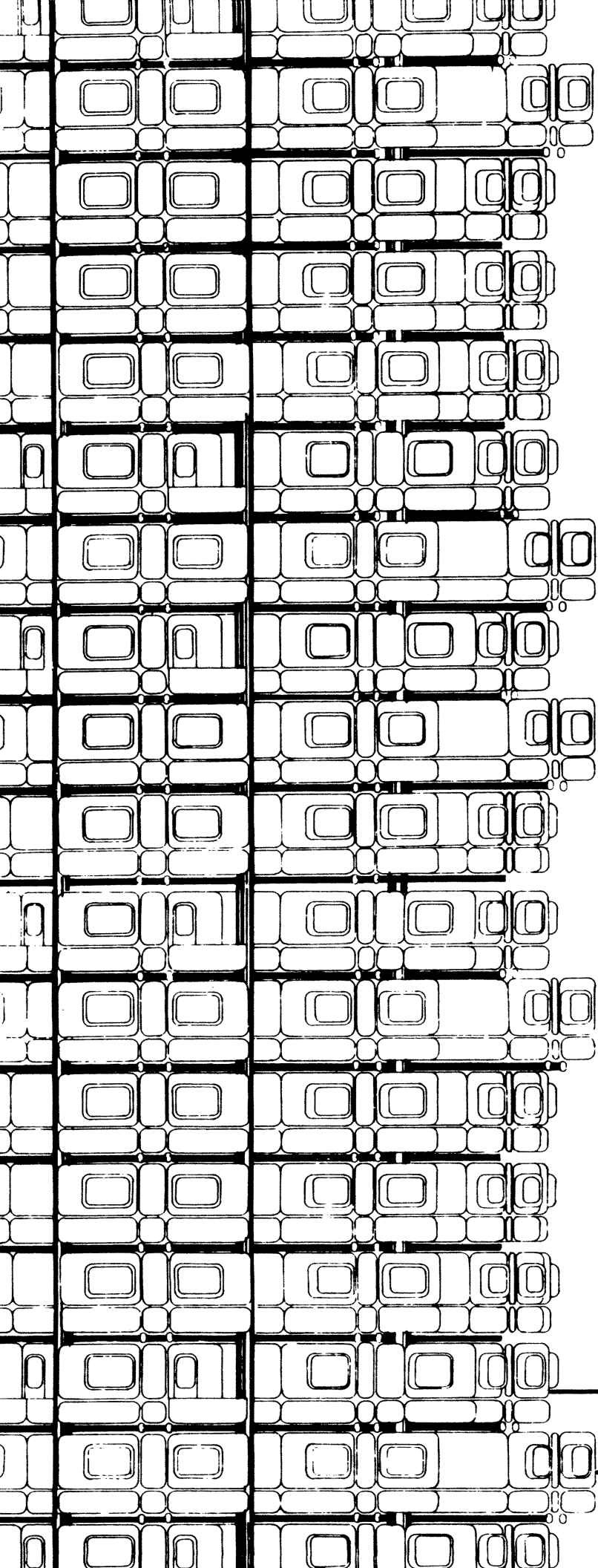

A Plug-In building in detail—Warren Chalk's Capsule-Unit Tower. Readers will doubtless observe a relationship to Bertrand Goldberg's Marina City towers in Chicago—spiral ramps of parking topped by floors of pie-wedge apartments. Each apartment, however, is an expendable living-capsule, available in various sizes as variations in the elevation show.

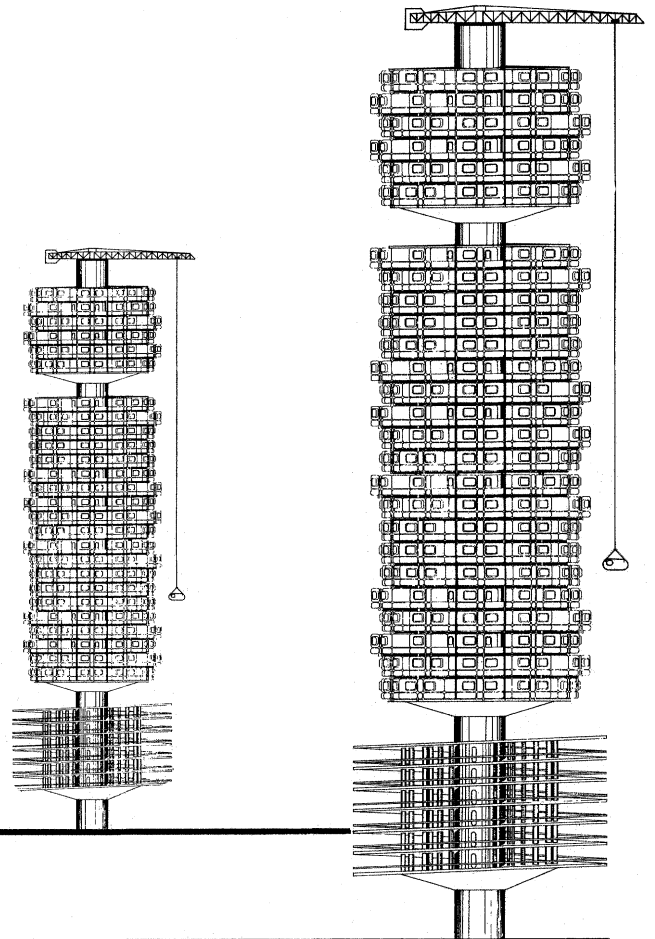

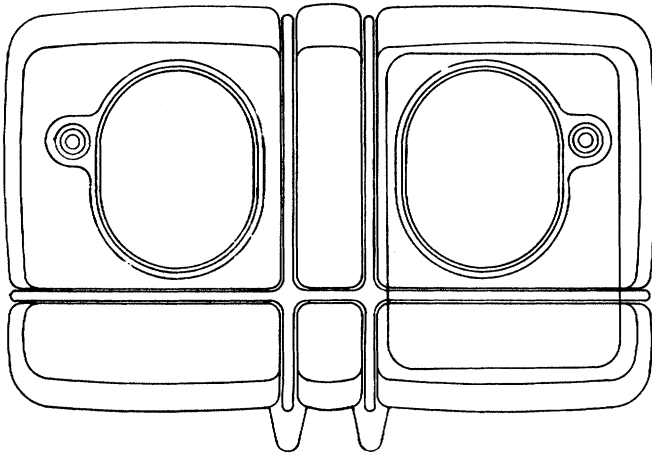

One typical capsule-unit with its built-in furnishings and equipment: in spite of numerous differences in construction and design, there is a strong feeling of a continuing aesthetic tradition from the Coulon-Schein motel capsules of six years earlier, the dwelling as an industrial designer's object, not a landbased monument.

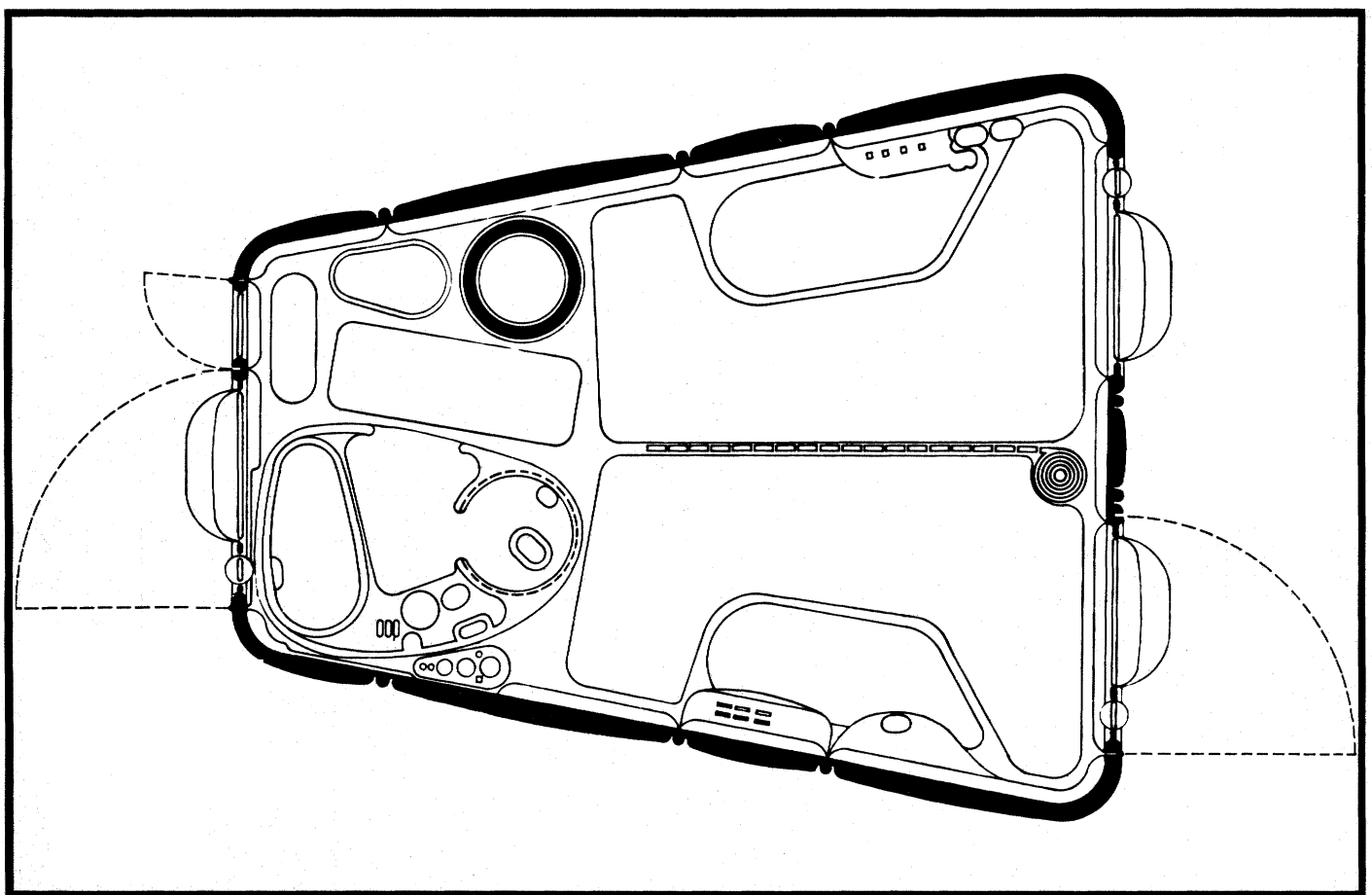

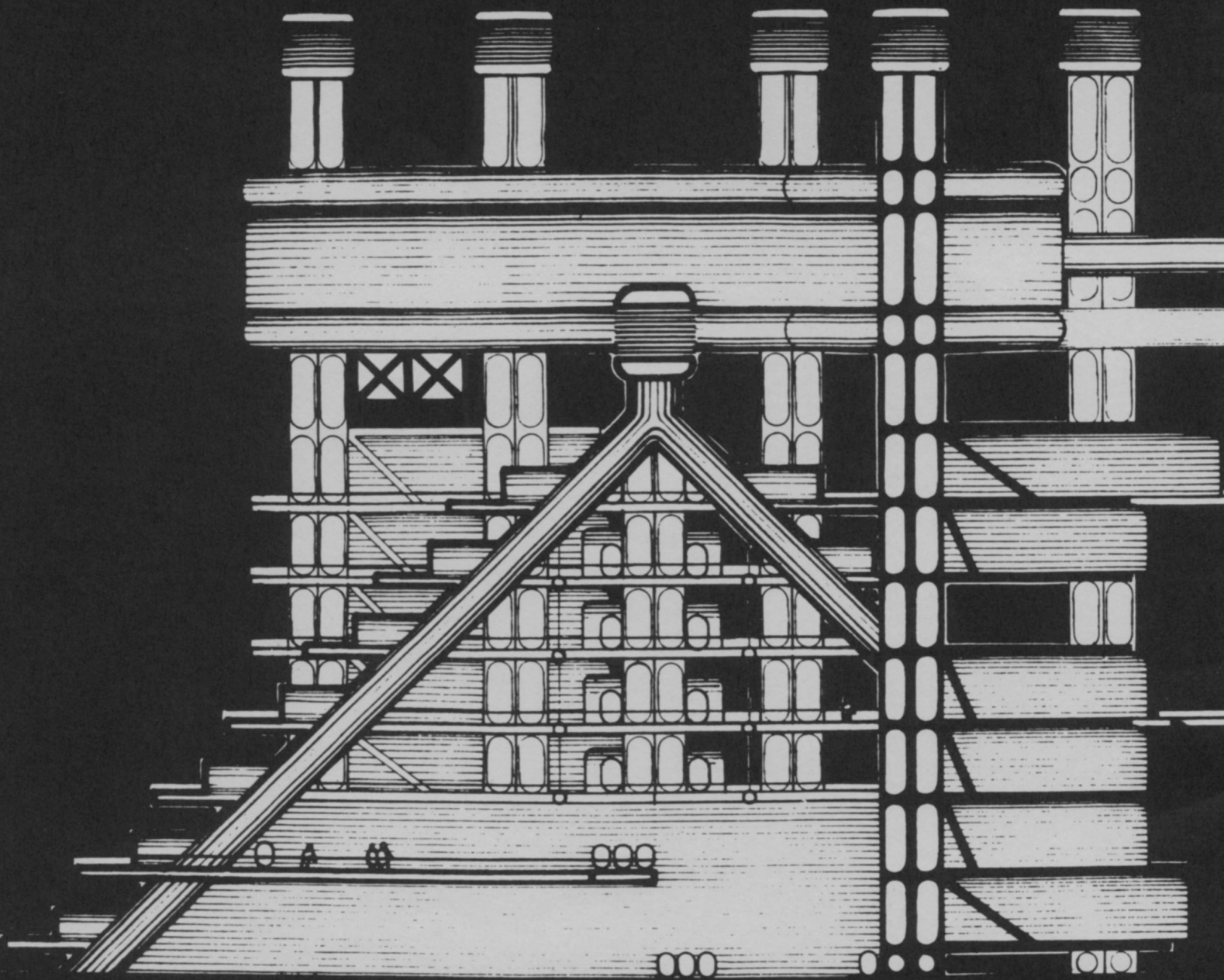

Plug-In University Node: Peter Cook's application of plug-in methods to the design of what is currently Britain's most compulsive building-type. These, however, with their information-silos suspended at the top of their structural pylons and teaching spaces clustered underneath, clearly escape Cedric Price's stricture on most recent British University architecture —“just the Middle Ages with 13-amp power-points.” Above all, this non-monumental solution is adaptable to changing university needs, as is demonstrated on the next page.

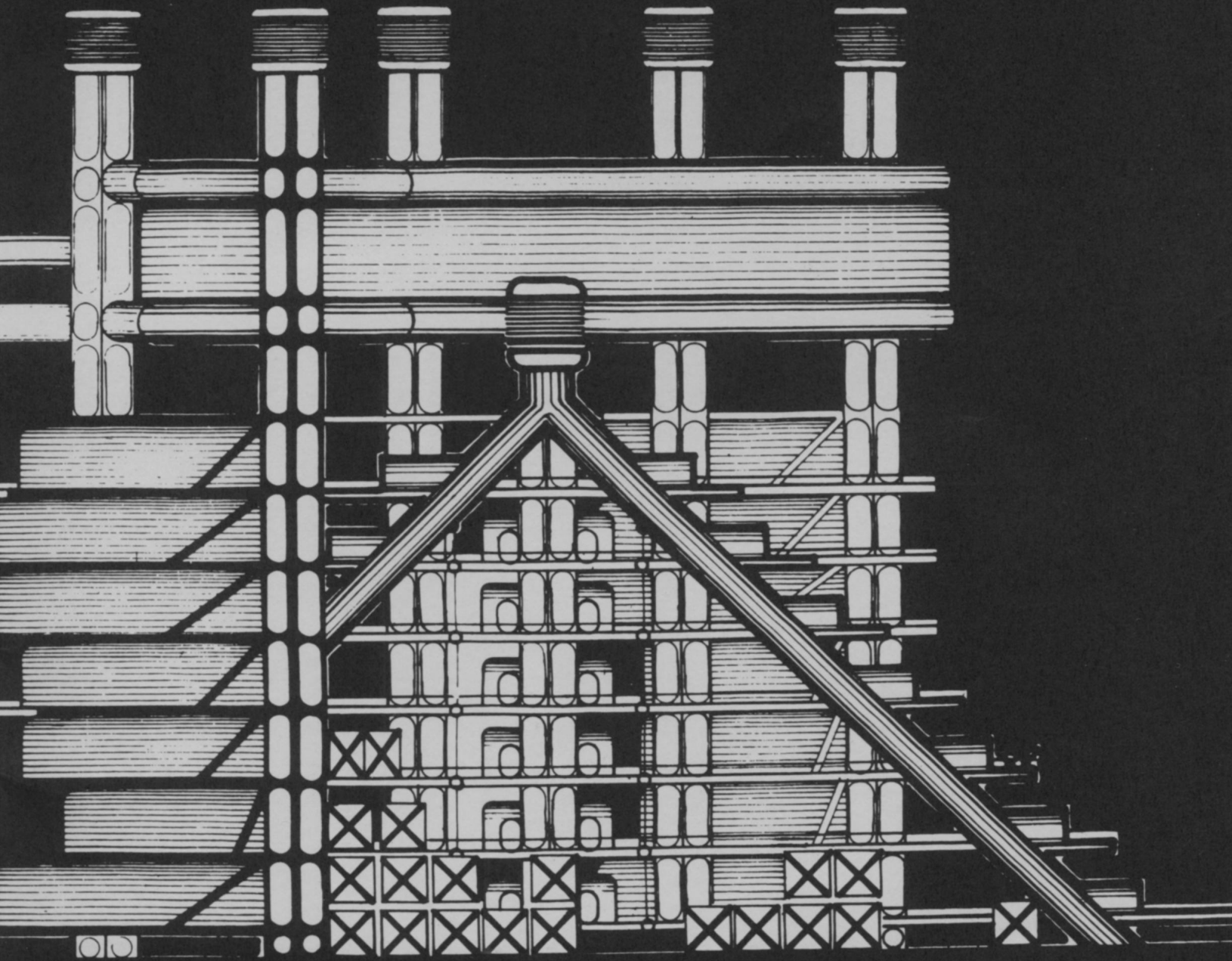

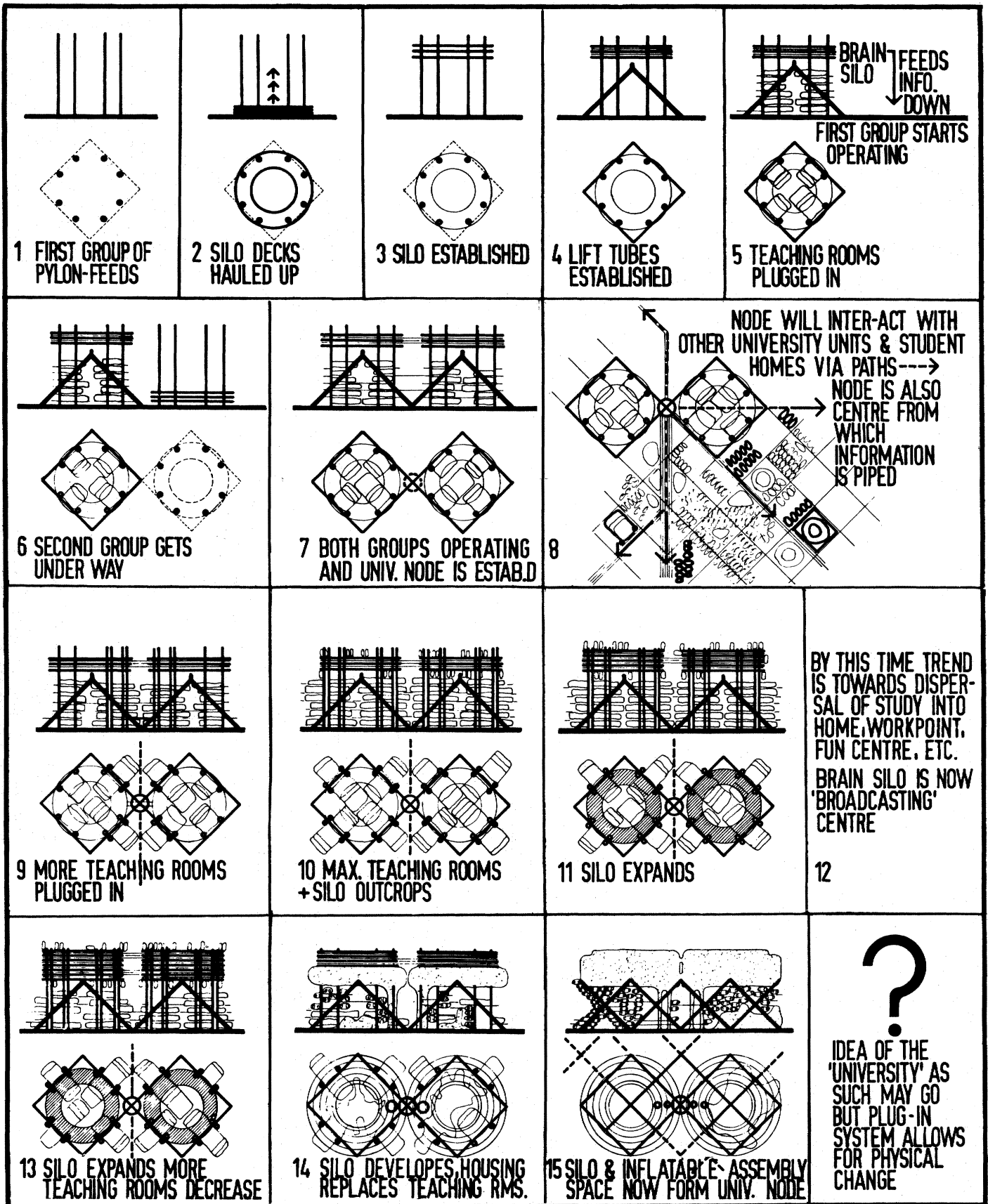

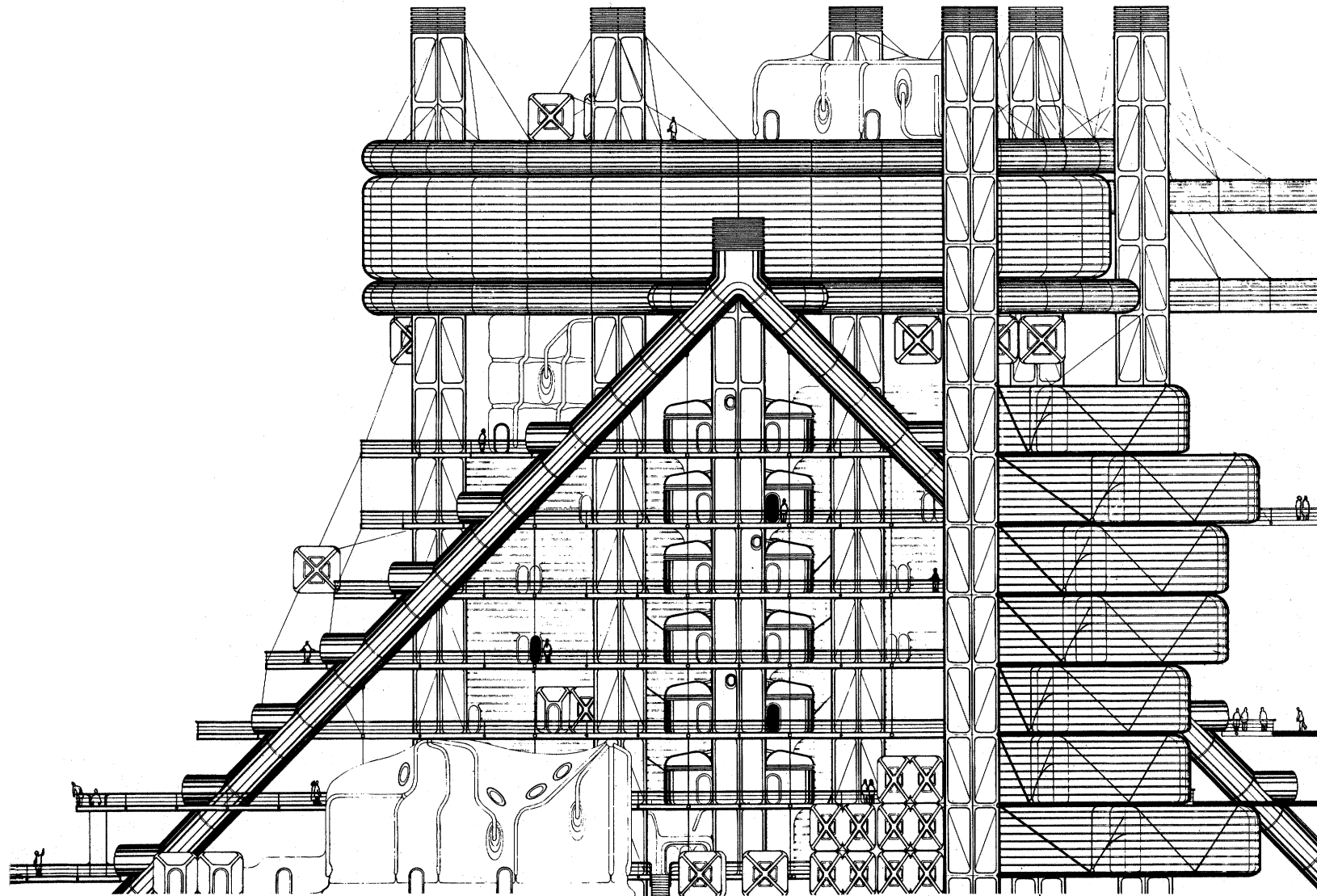

One pylon group (a half-node) seen in elevation above (complete with diagonal elevator-tubes) and full plan at right, in the condition of maximum occupancy by fairly conventional "live" teaching and circulation spaces, which correspond approximately to condition 10 on the opposite page.

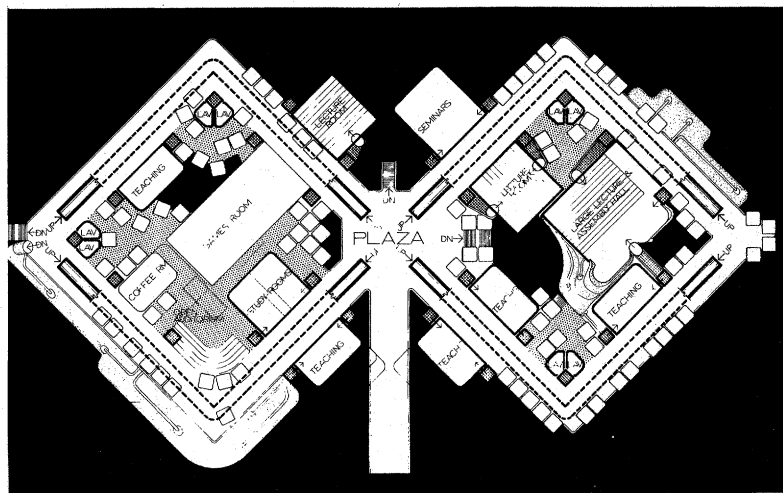

Opposite page: Construction sequence and subsequent transformations of the Plug-In University Node to accommodate different teaching methods and modes of university organization.

Plug-In City/Entertainment Tower/Capsule Unit/University Node

Archigram, the group of young British architects and designers, can't tell for certain whether Plug-In City can be made to work, but it can tell what it might look like. The magazine *Archigram*, published by this group, has developed over the past four years from a student broadsheet to something between an architectural space-comic and a magazine of protest. Rather suddenly, in 1964, it became an architectural magazine of international standing. Issue number 4, which was all space-comic with a Pop-up Zoom-city in its center spread, was taken up and quoted all over the world from *Architectural Forum* to *Architecture d'Aujourd'hui*, and Peter Cook, the editor, has had requests for the next issue from even further afield than that. The strength of *Archigram's* appeal stems from many things, including youthful enthusiasm in a field (city planning) which is increasingly the preserve of middle-aged caution. But chiefly it offers an image-starved world a new vision of the city of the future, a city of components on racks, components in stacks, components plugged into networks and grids, a city of components being swung into place by cranes.

They make no bones about being in the image business—like the rest of us they urgently need to know what the city of the future is going to look like, because one of the most frustrating things to the arty old Adam in most of us is that the wonders of technology have a habit of going invisible on us. It is no use cyberneticists and Organization-and-Research men telling us that a computerized city might look like anything or nothing: most of us want it to look like something; we don't want form to follow function into oblivion.

Archigram's visions of Zoom City, Computer City, Off-the-Peg City, Completely Expendable City and Plug-In City, may evoke yawns of impatience from the expert servants of the silent servitors mentioned above, but practically everyone concerned with architecture as constructed form (including plastics engineers) over-responds to the plug-in vision. They may reject it or accept it, but *Archigram's* kit of interchangeable living cells and support-structures seems to be the first effective image of the architecture of technology since Buckminster Fuller's Geodesic domes first captivated the world fifteen years ago. The difference from Fuller hardly needs to be rubbed in, except to hope that the opposite mistake in understanding will not be made. Buckminster Fuller offered (and still offers) a manner of thinking radically about the control of the environment, but the architectural profession ran off with the pretty bubble that housed the environment and soon got bored playing with it. A lot of technicians are going to pooh-pooh Plug-In City's technological improbabilities and brush it off as a kookie teen-age Pop Art frivolity, and in the process the formal lessons of the Plug-In City might be missed.

Put as tersely as possible, those lessons say this: a Plug-In City must look like a Plug-In City. If people are to enjoy manipulating this kind of adaptable mechanical environment (and if they don't enjoy it, we have gained nothing over previous environments) then they will have to be able to recognize its parts and functions, so that they can understand what it is doing to them, and what they are doing to it. And many of the future environments of man on this crowded little planet are probably going to be quite as highly mechanized as *Archigram's* Plug-In metropolis.

We started on this particular clip-on history with Llewelyn Davies offering a careful and respectful critique of the work of an acknowledged master, work which no one in Britain at that time could hope to equal. We finish with *Archigram* acknowledging the activities of other city-image specialists, but normally printing their designs smaller than its own. We started with Kallman making cautious propositions about what technology might do to aesthetics; we finish with aesthetics offering to give technology its marching orders, while magazines and pundits around the world wait for the word from London. No one—least of all the modest types who produce the magazine—wants to exaggerate the importance of *Archigram*, but its growing international reputation, backed by the threat of a real live Fun Palace (pilot scheme due later this year) suggests that the English contribution to the architecture of indeterminacy has now reached the point where its progress is worth recording.

Acknowledgments

We gratefully acknowledge the assistance of the following individuals and organizations for their permission to use the photographs, sketches and drawings included in this issue:

General Motors Technical Center, Warren, Mich., p. 4; Reyner Banham, p. 5, 8; The Illinois Institute of Technology, Chicago, Ill., p. 6; Architectural Review, London, England, p. 7; Jack Lynn, Ivor Smith, p. 7; Alison and Peter Smithson, p. 8; Jacques Baudouin, p. 9; Magnant/Coulon/Schein, p. 9; British Railways—Eastern Division, p. 11; Llewelyn-Davies, John Weeks, p. 11; Cedric Price, p. 12, 13, 14, 15; Members of the *Archigram* group: Warren Chalk, Peter Cook, Dennis Crompton, Bryan Harvey, Ron Herron, p. 16-17, 19, 21, 23, 24, 25, 27, 29.



The Author

Dr. Peter Reyner Banham, born 1922, in Norwich, England, is one of the senior members of the generation of critics and writers who came to the fore in the pages of *Art News and Review* (London) in the early 1950's. Originally he was destined for aero engineering, but worked later in various fields (theater, printing, public relations) before he enrolled at the Courtauld Institute, University of London, to read for the Bachelor's degree in the history of art. Armed with his degree and his *Art News* experience, he joined the staff of the influential London monthly, the *Architectural Review* in 1952 and remained with them until 1964.

During that time he completed a spare-time doctoral thesis, later published as *Theory and Design in the First Machine Age* (1960), began his career as a teacher (currently at University College, London) and embroiled himself, along with Lawrence Alloway and others, in the intellectual ferment which helped to produce the new London painting, particularly its Pop Art phase.

Now researching on a fellowship from the Graham Foundation, Chicago, he has become something of an Atlantic commuter, but remains based in London, living in Hampstead, together with a wife, a son, a daughter, an African finch, sundry cats and an art collection including works by Richard Hamilton and William Turnbull, and a general tendency for all horizontal surfaces to become piled with foreign art, fashion, architecture and motor-racing magazines.

DESIGN QUARTERLY issues available: single issues 60c each, double issues (numbers 18-19, 48-49, 50, 51-52) \$1.60 each. Beginning with number 61, single issues \$1.00, double issues \$2.00.

- Number 9 Outdoor Furniture and Accessories
- 10 Product Review 1949
- 11 Textiles and Designers
- 12 Lamps and Lighting
- 13 Everyday Art Exhibitions
- 14 Useful Objects / Work of Alvin Lustig
- 15 Tradition in Good Design
- 16 Tradition in Good Design: 1940-1950
- 17 Product Review 1951
- 18-19 Knife/Fork/Spoon
- 20 Contemporary Chairs
- 21 Product Review 1952
- 23 Made in Sweden
- 24 Product Review 1953
- 25 Fabric Designers and Their Work
- 26 Product Review: 20th Century Ballet Design
- 27 Five Ceramists and Their Work
- 28 Furniture Designers and Their Work
- 29 American design
- 30 Critical articles on contemporary painting and architecture
- 31 Contemporary book design
- 32 Tenth Triennale Product Review
- 33 84 Contemporary Jewelers
- 34 The story of Orrefors glass
- 35 Product Review 1956
- 36 Eight British designers and their work
- 37 Contemporary Finnish designers and their work
- 38 Product Review 1957
- 39 Eight designer-craftsmen
- 40 Industrial design in Germany
- 41 Product Review 1958
- 44 Product Review 1959
- 47 Product Review 1960
- 48-49 Fifty-seven American weavers and their work—
- 50 Art and Design in Hawaii—double issue—a salute to our fiftieth State
- 51-52 Japan: Design Today
- 53 Marcel Breuer
- 54 MacKenzie Pottery: Mendota Sculpture Foundry
- 55 Japan: Book Design
- 57 Children's Furniture
- 58 Tyrone Guthrie Theatre
- 59 Industrial Design in the Netherlands
- 60 Swiss Design Today
- 61 The 13th Triennale
- 62 Signs and Symbols in Graphic Communication
- 63 A Clip-On Architecture

