

EASY COME

DESIGN
QUARTERLY
#76



EASY GO



“What is the key word today? Disposable. The more you can throw it away the more it’s beautiful. The car, the furniture, the wife, the children—everything has to be disposable. Because you see the main thing today is—shopping. Years ago a person, he was unhappy, didn’t know what to do with himself—he’d go to church, start a revolution—something. Today you’re unhappy? Can’t figure it out? What is the salvation? Go shopping. . . .

I’m telling you the truth! If they would close the stores for six months in this country there would be from coast to coast a regular massacre. With [old fashioned] furniture the shopping is over, it’s finished, there’s no more possibilities, you got it, you see? So you got a problem....”



*From "The Price" by Arthur Miller.
Copyright ©1968 by Arthur Miller and
Ingeborg M. Miller, Trustee, all rights
reserved. Reprinted by permission of
The Viking Press, Inc.

Design Quarterly 76

**Easy Come,
Easy Go**

**Notes
on
Ephemera
by
Daniel
Solomon**

**Walker
Art Center,
Minneapolis,
Minnesota**

Copyright 1970,
Walker Art Center.

Introduction and Acknowledgments

all elements which have been critical factors in the world of fashion for centuries. The movement of these terms into the real world of architecture and environmental design is beginning to cause an erosion in the wall of architectural truths which have guided students for many years.

The reason for this shift in critical thought is not arbitrary—it is based on technological developments outside of the design fields that are finally being absorbed into the vocabulary of architects and planners. Various forms of systems analysis and related production techniques, together with the theoretical analyses by the new breed of ecologists, are beginning to appear in the actual products of architectural planning (e.g. Paul Rudolph's high-rise trailer park). What these changes will mean ultimately will depend, as always, upon the uses to which our technological advances are put, and, probably more than that, on the ability of designers to incorporate change and retain flexibility at a rate much faster than has ever been required in the past.

DESIGN QUARTERLY 76 developed from an initial interest in the burgeoning area of design called "Supergraphics." After some discussion with Barbara Stauffacher and Daniel Solomon, it was clear that temporary graphics should not be an isolated subject because it relates directly to the larger problems of disposability and impermanence. These issues, to the dismay of some of our sterner colleagues, are becoming more and more the stuff of design.

In developing his thesis, Mr. Solomon treats a number of areas which are philosophical "hot-potatoes" in American schools of architecture and design. The question of style as opposed to fashion, the superimposition of non-architectural elements on structural forms, the temporary or disposable as opposed to the permanent are

Walker Art Center is especially grateful to the Graham Foundation for Advanced Studies in the Fine Arts, Chicago, whose continuing support has made DQ 76 possible.

The following individuals have contributed material and generous assistance in the preparation of this issue:

Mr. Edmund Bacon, Philadelphia; Mr. Jeremiah O. Bragstad, San Francisco; Mr. Joshua Freiwald, San Francisco; Mr. James Geye, Minneapolis; Mr. Michael Shiffman, Berkeley.

Mr. Dean Swanson, Chief Curator of Walker Art Center, made initial contact with the author and designer and has contributed important advice throughout the production of this issue.

M. S. F.



One-trip, plastic-paper beer bottle carton.

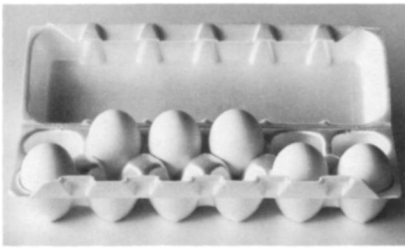

Styrofoam egg carton.



Laminated, paper-vinyl-foil bib.



**Paper wedding dress. "Sweden Now"
Freddy Pedersen, Photographer.**

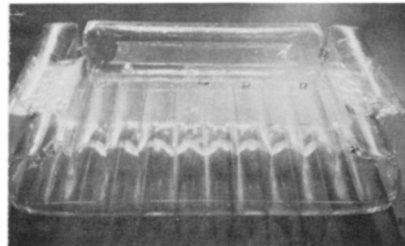

**Inflatable vinyl sofa.
Jensen-Lewis.**



**Construction fence,
Fifth Avenue, New York, NY.
Barbara Stauffacher Solomon.**



**Migrant farm worker housing.
Hirshen & Van der Ryn, Architects.**

More and more of the man-made world is ephemera—plastic champagne glasses, aluminum foil haute couture, paper houses for migrant farm workers, demountable classrooms. We make disposable packaging, disposable dishes, and disposable dresses. Some new architecture is disposable and a great deal of it is mobile. In most industries the impulse to build pyramids or Stonehenges does not exist. Automobiles last five years, mobile homes about ten. The life expectancy of many sorts of objects grows shorter and also more rigidly preordained. Six million Swedish babies wear paper diapers and their mothers can buy six-packs of paper panties at the grocery store. It is the purpose of this issue to explore this world of ephemera, what it is like visually, why it exists, and what is the relationship between disposability and mass production. It will also ask whether some day soon the material environment at large, and not just objects within it, might become increasingly disposable. There are two related trends which are undeniably afoot. One is a proliferation of disposable objects being produced by the packaging industry, the building industry and the world of fashion. The second trend is the development of large-scale architectural schemes which divide the physical environment into a permanent sector and a temporary sector.

Disposable packaging is not new and its advantages and problems are well-known. Larger disposable things like clothing and furniture are now an established part of the scene. However, it is not so clearly established that disposable architecture is a good thing or soon likely to exist on a large scale.

The packaging industry, the automobile industry and the aero-space industry all manufacture products with short and fixed life expectancies. Two generations of architects and others involved in building have watched the technological achievements of these three

industries with envy and embarrassment. One of the most tenacious, most universal, most thoroughly unfulfilled fantasies of modern times envisions superb machines making good and cheap houses by the millions as if they were Fords or aerosol bombs. Aging professors of architecture drag their students through automobile assembly plants with the vicarious, maybe-you-can-make-it-son ambition of Little League fathers. The rhetoric of "systems building" has been passed intact for generations with George Romney prophesying a new age in the 1970s in almost the same words with which Le Corbusier prophesied a new age in the 1920s.

The history of industrialized building in the United States is a long, sad story of shattered careers and lost fortunes, but for more than forty years it has been obvious to many people that the organizational apparatus for the production of architecture is an anachronism of incredible dimensions. Buckminster Fuller wrote the following in 1927:

"If, today a man, wishing to acquire an automobile, were to visit one of five thousand automobile designers in New York City, equivalent to New York's five thousand architects, and were to commence his retention of the designer by the limitation that he wanted the automobile to resemble outwardly a Venetian gondola, a jinricksha of the Tang Dynasty, a French fiacre, or a Coronation Coach of Great Britain, pictures of which he had obligingly brought with him, all final embellishment, of course, to be left to the election of his wife; and he and the 'designer' were together to pick and choose (from automobile accessory catalogues, advertisements, and 'shows') motors, fly wheels, fenders, frame parts offered in concrete, brass, sugar cane fibre, et cetera, and succeeded in designing an automobile somewhat after the style of some other fellow; and they were then to have the design bid upon by five local garages in Queens Village, picking one of the

bidder for his ability, or price; and the successful bidder, chosen, let us say, because of his having built grandfather's velocipede, were to insist on the use of some other wheels than those specified; and the local bank, in loaning the money to the prospective 'owner' to help him finance, had some practical man look over the plans so that, guessing at the cost, he might base a loan thereon, incidentally insisting on the replacements of several parts and methods by others in which the bank was 'interested'; and then the insurance company were to condemn a number of the units used because they had not been paid for their 'official approval' and compel the substitution of other units; and fifty material and accessory manufacturers' salesmen were informed by a reporting agency, whose business it was to ferret out this poor man's private plans, that he was going to 'build' a car, and were to begin hounding him with specious promises; and, finally, if the local town council had to approve of the design and materials and give a permit for the automobile's construction, sending around assertive inspectors, while it was being erected, it is certain that few of those desiring automobiles would have the temerity to go through with the ardors of acquiring them . . .".*

Reyner Banham, Carl Koch, Peter Cook, and Ezra Ehrenkrantz,** to name just a few, have all made the same point in different ways. The point is, of course, that the automobile industry is a modern one, taking advantage of

*From "Nine Chains To The Moon" by R. Buckminster Fuller. Published by Lippincott Co., New York, 1938. Reprinted by permission of R. Buckminster Fuller.

**"Clip on Architecture" by Reyner Banham. Design Quarterly, No. 63: 1-31, 1965.

"At Home With Tomorrow" by Carl Koch with Andy Lewis; Rinehart, New York, 1958.

"Architecture, Action and Plan" by Peter Cook; Reinhold, New York, 1967.

"The Modular Number Pattern; Flexibility Through Standardization" by Ezra D. Ehrenkrantz. Published by A. Tiranti, London, 1956.

standardization, modular coordination, automation, research, and large scale distribution and marketing; while the building industry, by and large, is a loose confederation of medieval guilds, puny jurisdictions and jealously protected handicrafts. The current racial antagonism within the almost totally white building trades unions is only symptomatic of the historic inability of these unions to cope with social and technological change of many sorts. What other industry has an organized (though unofficial) anti-integration, anti-job-training campaign in 1970?

Since 1927 automobile building has advanced fantastically and house building only a little. An automobile buyer today can, within limits, write his own specifications (4-on-the-floor, 427, mags, tach, angora carpets) and an automated assembly plant makes the thing for him. The next car on the assembly line may be entirely different (Econoline 6 ranch wagon with automatic). The craftsman movement of the 19th century never dreamt of user-participation in design on the scale that Detroit has achieved it.

A family making \$10,000 a year may spend \$100/month for a \$3,000 car which is totally depreciated in five years. They also spend \$200/month on a \$20,000 housing unit which takes 40 years to depreciate. Strangely, equity in a car costs more than equity in a house. A 25 year old house may be worth more than its original cost because it is likely to be technically and aesthetically better than a new one. The consumption of natural materials and the demands of the fragmented and highly aggressive building trades unions have made it so. A house is a good investment for very bad reasons. Buy a house today, because tomorrow there will be fewer of them, and they will be more costly, less attractive and flimsier.

It is, of course, meaningless to say that a modern car is "better" than a modern housing unit. But

one can say that the \$3,000 for the car is better spent than the \$20,000 for the housing unit, if both are analyzed in terms of labor costs, material costs, research and development, marketing costs and fees to middlemen. The \$20,000 for the housing unit is mostly labor and fees, some material and virtually no research and development. The \$3,000 for the car is mostly material, research and development, a fair amount of marketing and very little labor. So a modern car is a more thoughtfully conceived and efficiently produced product than a modern dwelling.

Modern production methods, research and development cannot be mobilized economically on behalf of any product for which there is not a steady and predictable demand. Things cannot be produced efficiently unless they are purchased at approximately the same rate they are produced. If housing becomes subject to continual obsolescence it will create for itself a steady and predictable demand but it will no longer be a good investment. Instead of being equity, it will become a consumer product like the automobile. Unfortunately an object cannot be technically up-to-date unless it is consumed, and if it is consumed, the money that paid for it is consumed as well. This may be disadvantageous from some points of view but it is surely outweighed by the overall impact on economic growth created by a large scale, successful, mass production industry.

American building, with its dependence on the whims of the economy and the pace and scale of real estate transaction, has not normally been the least bit predictable or steady. Because of its spasmodic character, it has managed to elude the 20th century almost entirely, both in the quality of its product and the efficiency of its organization. A factory, producing 20 buildings a day, creates for itself an immense and expensive storage problem if its clients can prepare building sites at a rate of only 10 per day, or if it takes them a

WASTE MANAGEMENT SYSTEM

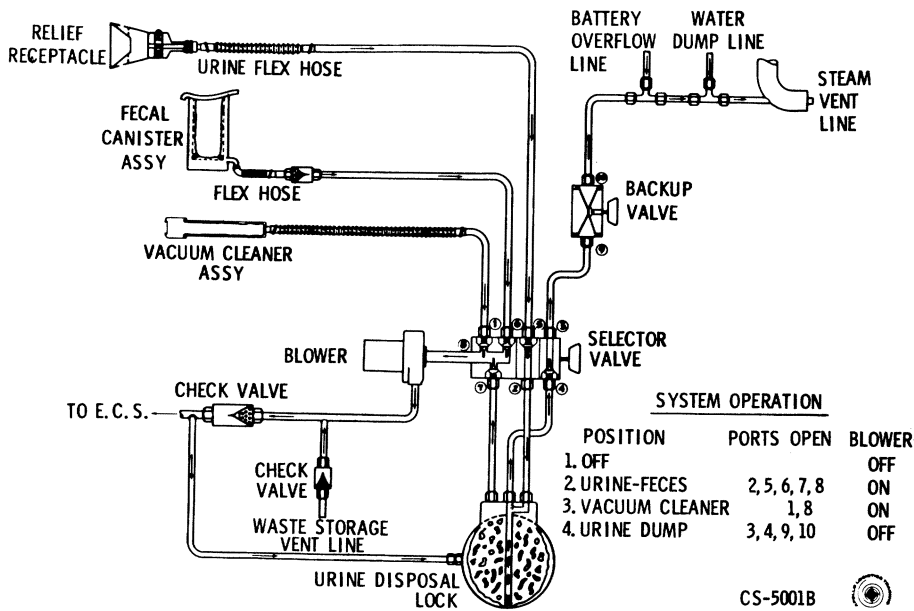

Apollo command module plumbing scheme.

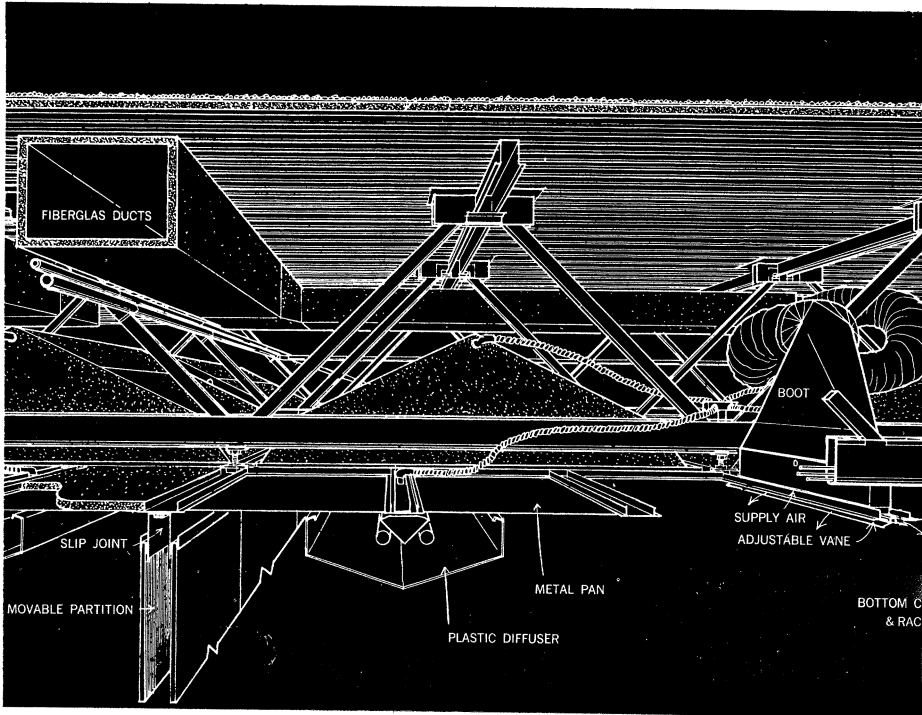

SCSD School System, schematic section.



SCSD school under construction.

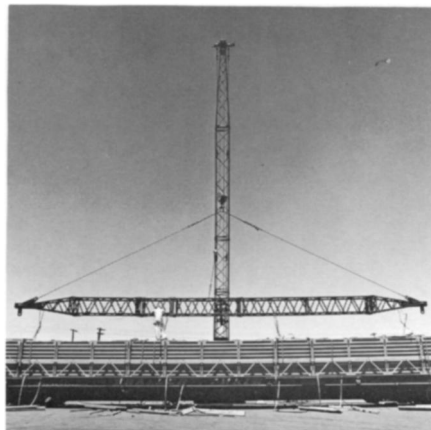

year to assemble land for a major project. On the other hand if the clients must pay interest on \$10 or \$20 million as soon as they take title to a piece of property, a factory producing 20 units a day is impossibly slow. The present building industry with its instantly mobilized and demobilized army of little men, nailing sticks together one by one, has resisted the onslaughts of industrialization with the same resilience and tenacity that the North Vietnamese highway system resisted bombing—and for the same reasons. Its crudity, its flexibility, its non-commitment to facilities, training and research are its salvation. The Apollo spacecraft has a recirculating waste system, but plumbing for earth people was developed in its essential features by the Romans.

The few successful attempts to industrialize American building have occurred only when some group, through Herculean wheeling and dealing, has been able to approach industry, contract in hand, with a predetermined market. Ezra Ehrenkrantz's SCSD schools are a neat example of this process.

Ehrenkrantz utilized a series of foundation grants to do basic work on school systems and to assemble a proposal which produced commitments from 13 school districts for more than \$30 million of school construction, if certain cost and performance criteria could be met. With these commitments Ehrenkrantz and his staff were able to enlist more than 100 major manufacturing firms to do speculative design development and to bid on various components of the school system. The prior commitment to a reasonable production run gave Ehrenkrantz the leverage to undertake design development, of the sort normally associated with products, not buildings, and to create radically new relationships among consultants, manufacturers and clients. The prior commitment enabled them to attack, albeit in a relatively small way, the organizational apparatus by which architecture is currently produced.

By and large, American attempts to harness industry to make radical changes in building techniques have not been this shrewd. There have been scores of technically worthwhile innovations which have been under-capitalized or drowned in the penury of union negotiations and code approvals. Proper marketing and franchising appears to be the largest single obstacle to achieving the house that is made like a car.

Probably the largest, most famous and most nearly successful of these failures in the United States was the post World War II Lustron House, which consumed \$33 million of federal money before going under in 1950. It was the brain-child of Carl Strandlund, who was a manufacturer of enameled steel products and an engineer with friends in high places and the ambitions of a Citizen Kane. The Lustron plant began as a converted fighter plane factory with 23 acres of presses, furnaces and high-speed welding machines capable of producing a complete 1,025 sq. ft. house every 14 minutes, 100 of them a day. The houses were enameled steel and came in four colors. They were neatly planned and well-insulated and they were dull as dross. Strandlund was fascinated with his factory, and with raising money but his product was far less ingenious and interesting than the organization that produced it. Strandlund did not choose to hire first-rate architects, but whether Eames or Breuer could have designed a more marketable, factory produced steel house is not important. The point is that the Lustron House was nothing more spectacular than an all right, medium priced house that could be made in great numbers with little labor. This is not the stuff that industrial revolutions are made of.

To many people involved in the development of industrialized building, the Lustron House is the paradigm of the immobility, anachronism and strangling bureaucracy in which the American building industry is

mired. Frequently the failure of efforts like the Lustron House, which must number in the hundreds, are contrasted with the massive success of factory produced building in Eastern Europe. It is probably safe to say that almost no one in the capitalist West really admires much of the architectural design and urban planning practiced in Eastern Europe. But there are a great many people in the design professions, in industry and in government here who do admire the efficiency and effectiveness of the building industries in Russia, Czechoslovakia, Hungary and East Germany, and the scale on which they have dealt with environmental problems. It is easy enough to see the difference between our own comic opera efforts, through federal subsidy programs and the FHA, and 2 million housing units built in the USSR in 1968.

For more than a decade there has been a serious commitment, not a rhetorical one, by the Russian government to utilize the best resources of their industry and management to build houses. The first successful automotive style, multi-station conveyor factory for the production of dwellings was built at Luberetsk outside of Moscow in the late 1950s, and there is continuous government sponsored research in new methods and tools for manufacture and assembly. Unlike this country, innovations like plastic pipe and factory installed plumbing and wiring have not been forestalled by recalcitrant building trades unions. Before beginning to build in earnest, the Russians spent the equivalent of \$3 billion on housing design development and research. Our largest annual commitment to similar activity was \$10 million in 1967.

In Eastern Europe generally there is a massive technical literature on industrial building, which has no real parallel in the West. Using an American university library, it is fairly easy to find something about the thermal insulation, per-unit cost for different types of concrete in Budapest, but impossible to



Precast panel building in Hungary.

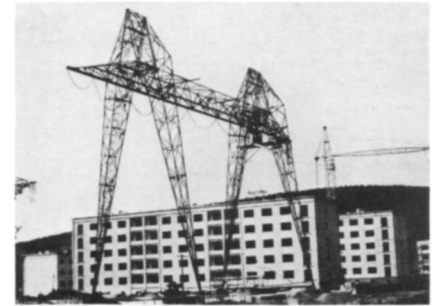

Panel buildings and gantry, Gottwaldov, Czechoslovakia.

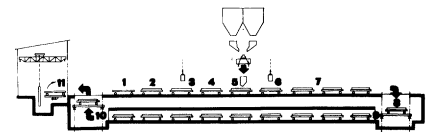

Precasting works for the production of large panels at Hoyerswerda, GDR, with a conveyor system.

Lustron House,
1949.
Acme News
Pictures, Inc.

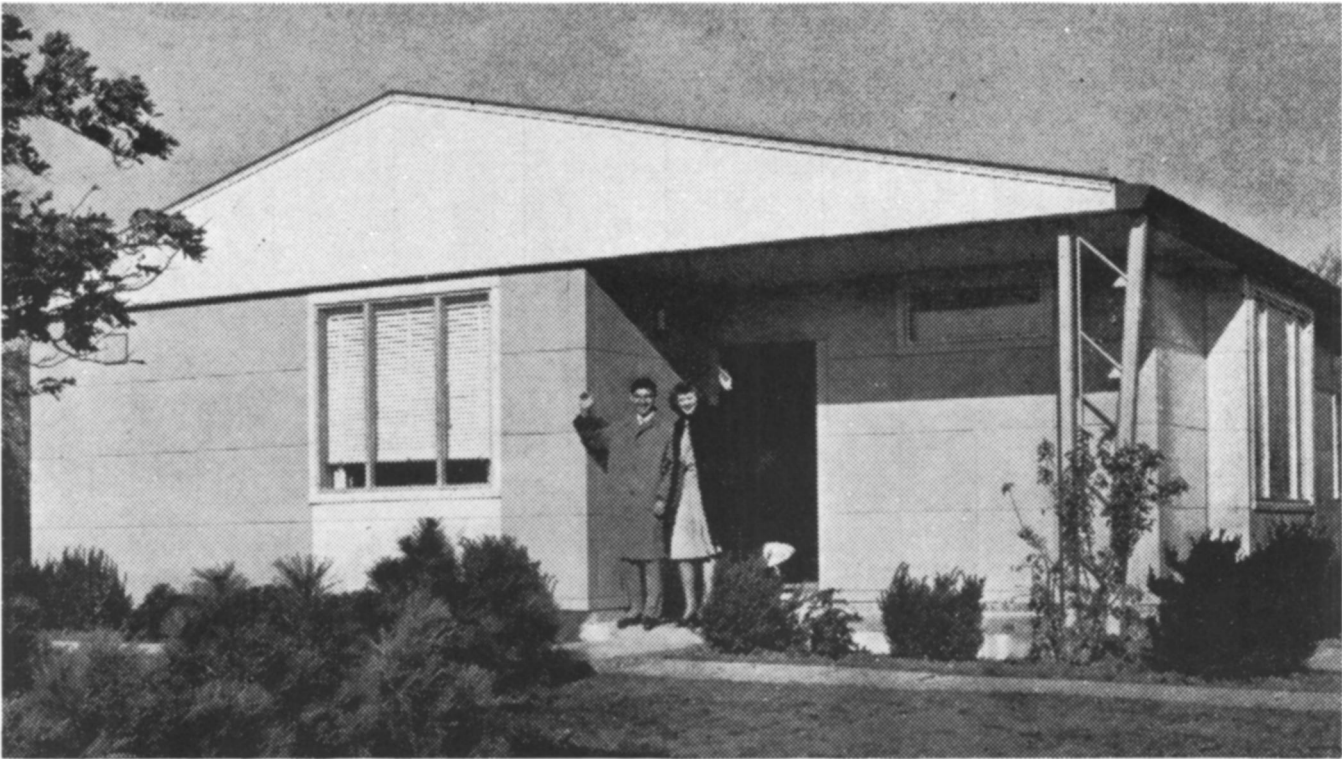

Karl Stranlund.
"Life," A. Haug.

1947 Kaiser
Custom 4 Door.
Kaiser-Jeep
Corporation.

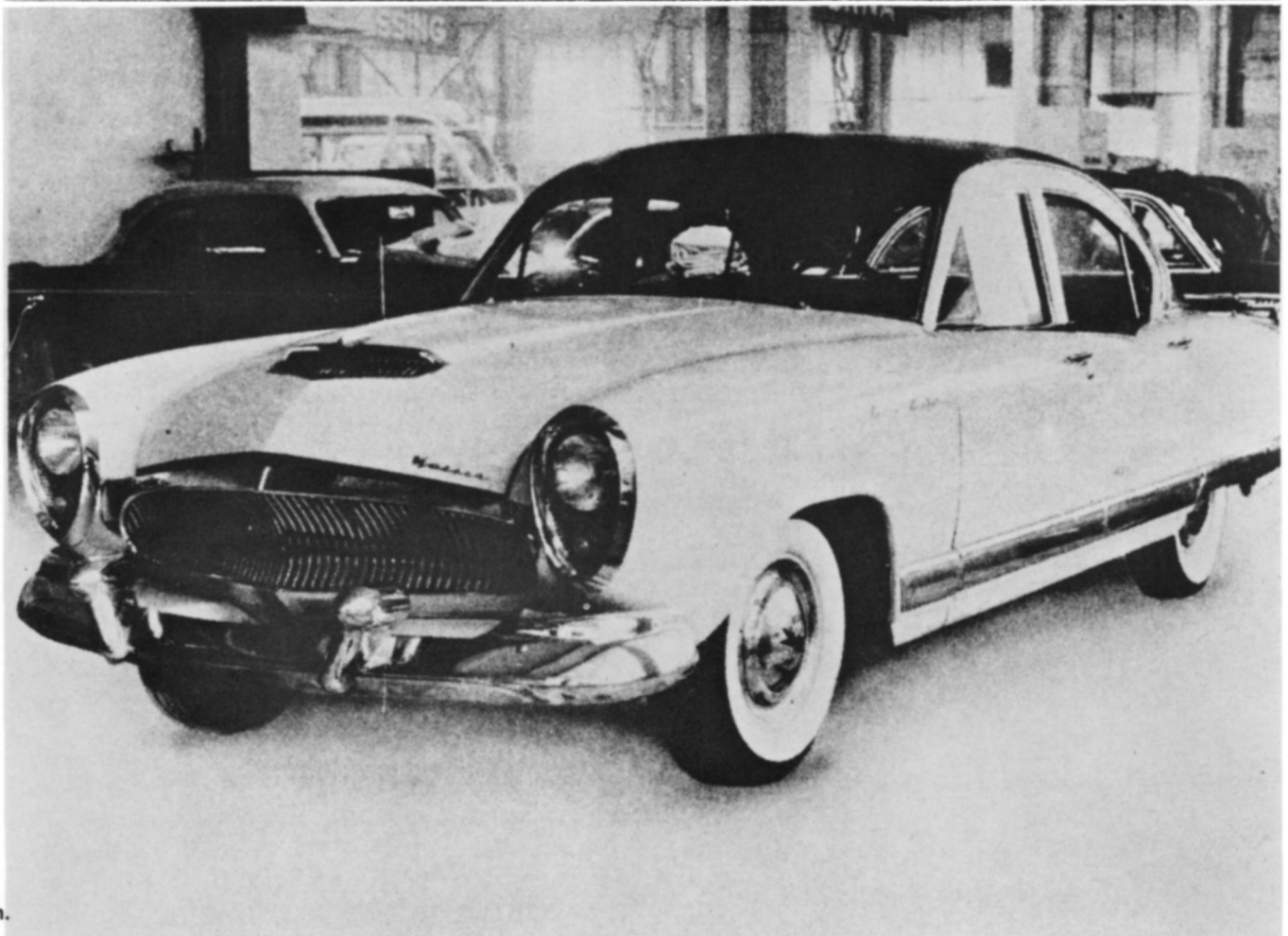
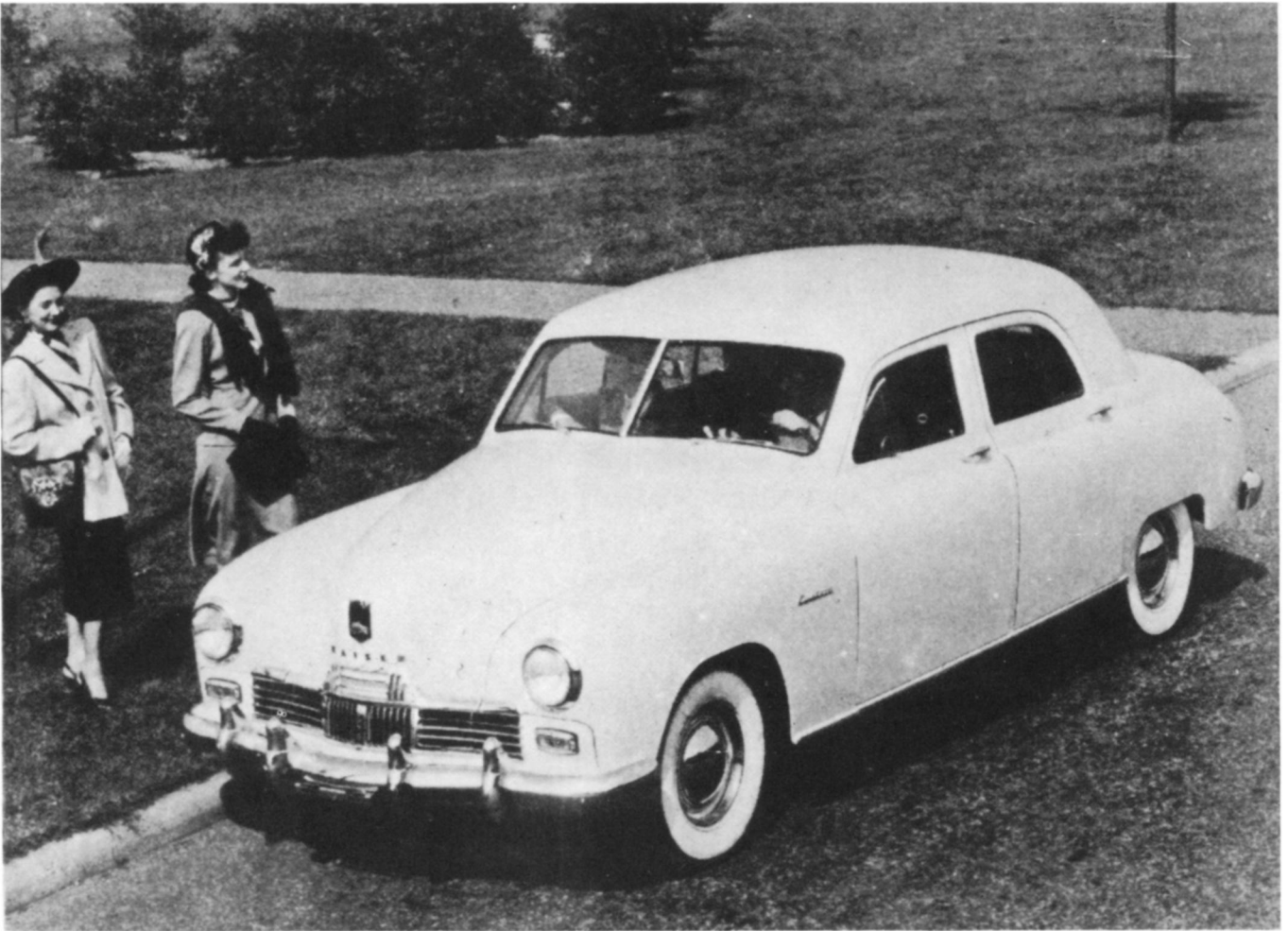

1954 Kaiser
Manhattan sedan.
"Motor."

find the same information for concrete produced in Los Angeles.

Czechoslovakia, Russia, Hungary and East Germany have achieved what we have not—a rationally organized housing industry producing millions of units each year. Yet for all its technical excellence and economy, the environment produced by this massively efficacious new industry would not be welcome in the West. The western developments probably most similar in style and scale to housing in Eastern Europe are the new suburbs of Paris, and these are regarded with horror by most Parisians and the architectural and popular press.

It is strange that Russian housing should be an object of infatuation to so many western technicians. It is strange too that after 20 years the Lustron House should still be cited as a tragic example of a near miss. From the distance at which we observe them both, they appear to share one clear and overriding trait, and that is their utter, crashing banality. It is hard to feel a sense of grief that these dour progenies of mass production are not being built all around us. In retrospect, the most interesting trait of the Lustron House is the degree to which it missed the whole marketing ethos that forms the basis for the packaging and automobile industries and so much of American life.

The Lustron House seems to be a curious example of missing the point on a really colossal scale, in quite the same way that the early Kaiser-Frazer automobiles did. Kaisers and Frazers, like the Lustron House, were start-from-scratch projects, employing the mass production lessons and facilities of World War II. They were solid, cheap, comfortable cars and there was nothing really wrong with them except that they were just awful. If it is possible for an object to achieve intense dullness, Kaiser's cars did it. Kaiser recognized its mistake after a couple of years' production and hired Charles Darin, one of the original Kalifornia Kustom Kar

Kings, to coif the second generation of Kaisers and Frazers. But Mr. Darin, alas, was the wrong man with the wrong solution at the wrong time. His designs were as tinsely as the earlier ones were drab, but it was too late anyway; Kaisers and Frazers were by then labeled as irredeemable losers in the public mind.

William Buckley reported in "Esquire" magazine that Joe Namath took the hand of a young lady at a cocktail party, moved it to his fly and said "That's all America wants from me." This may or may not have happened but regardless of whether Namath said it or Buckley dreamt it, one of them knows the secret that eluded Kaiser, le Corbusier, Fuller, Strandlund and all the rest. Joe Namath is what America loves best: a phantom phallus conquering the world on shaky legs. Nobody knows how long the right knee will last—maybe one more season, maybe one more game. All we know is that tomorrow or the next day, wonderful Joe, Joe of the white shoes, will be gone. He is in fact so ephemeral, so clearly a product of television and the daily press, that by the time this is printed he may be a forgotten man.

Technical excellence for most objects depends on mass production and in capitalist countries mass production depends on mass marketing. Mass marketing belongs to the cosmos of fashion, show business, sports and the communication media. All of these things survive by being topical, notorious, sexy and changeable. This is simply a fact about our culture and a very pleasant and entertaining fact. Automobile people, of course, have known this for years and exploited it superbly. In their 1970 literature, Ford has announced, in language from the want-ads of an underground newspaper, that you can add 155 horsepower to your 1970 model by ordering a "dominator" kit from the "Muscle Parts" catalogue put out by a Ford subsidiary. Machismo in any form is a marketable

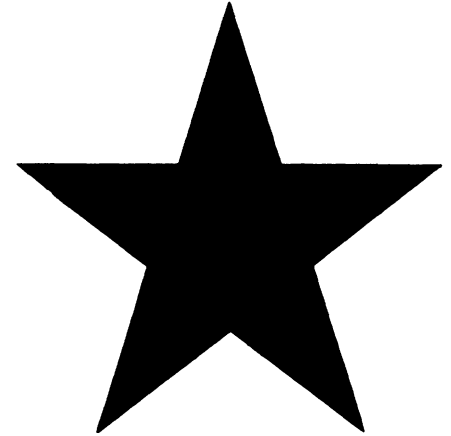



GO AHEAD,
YOU FOOLISH GROUPIES,
FALL IN LOVE WITH
HIM...

...AND
LET HIM
HURT YOU
LIKE HE
DID **ME!**

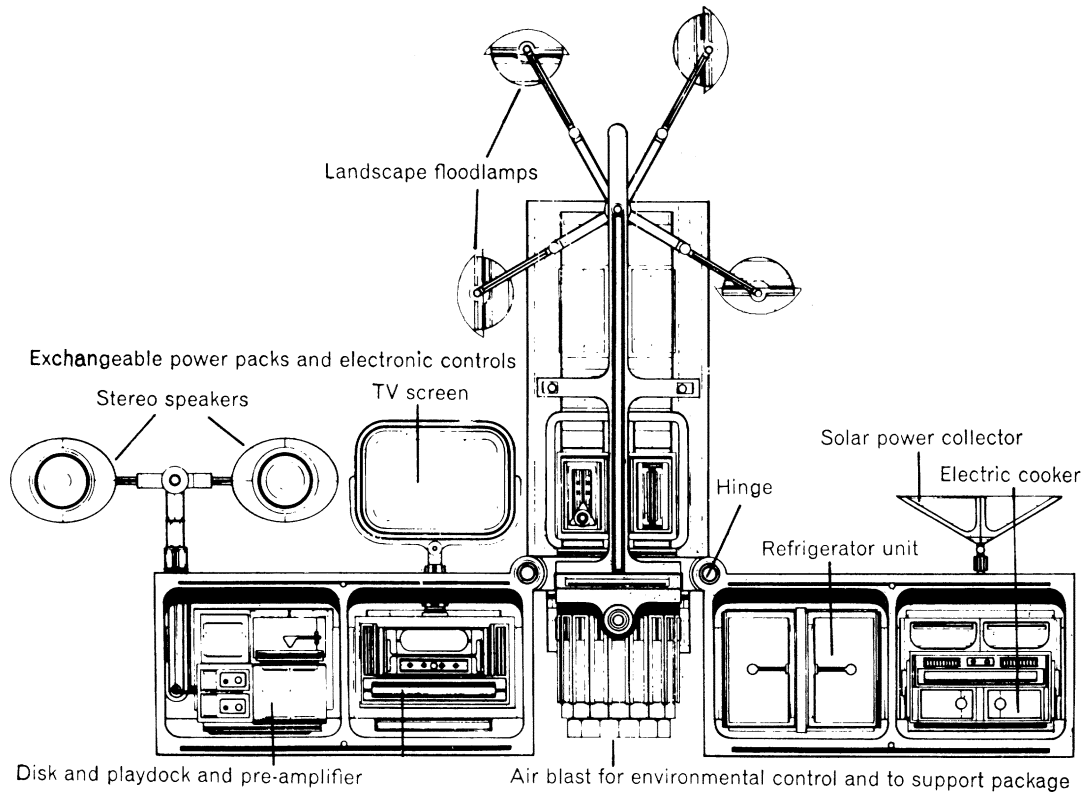

Media Center, François Dallegret.

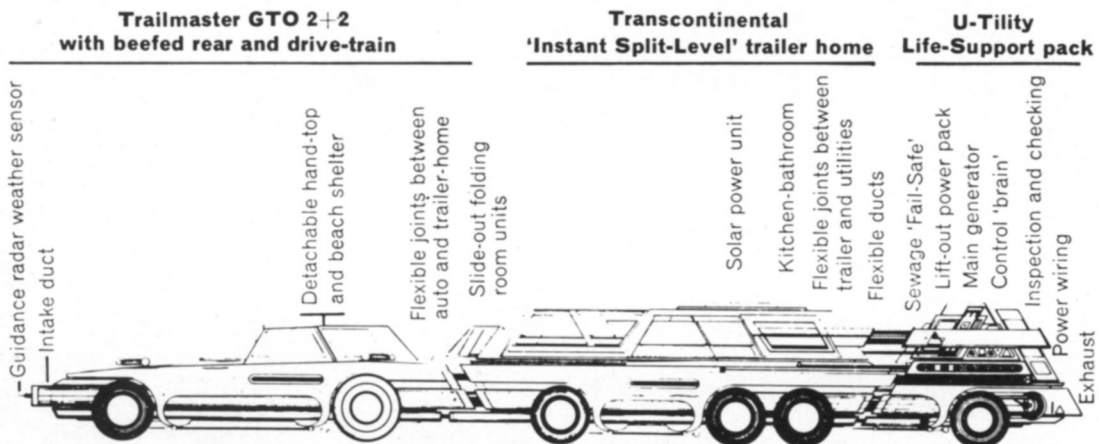
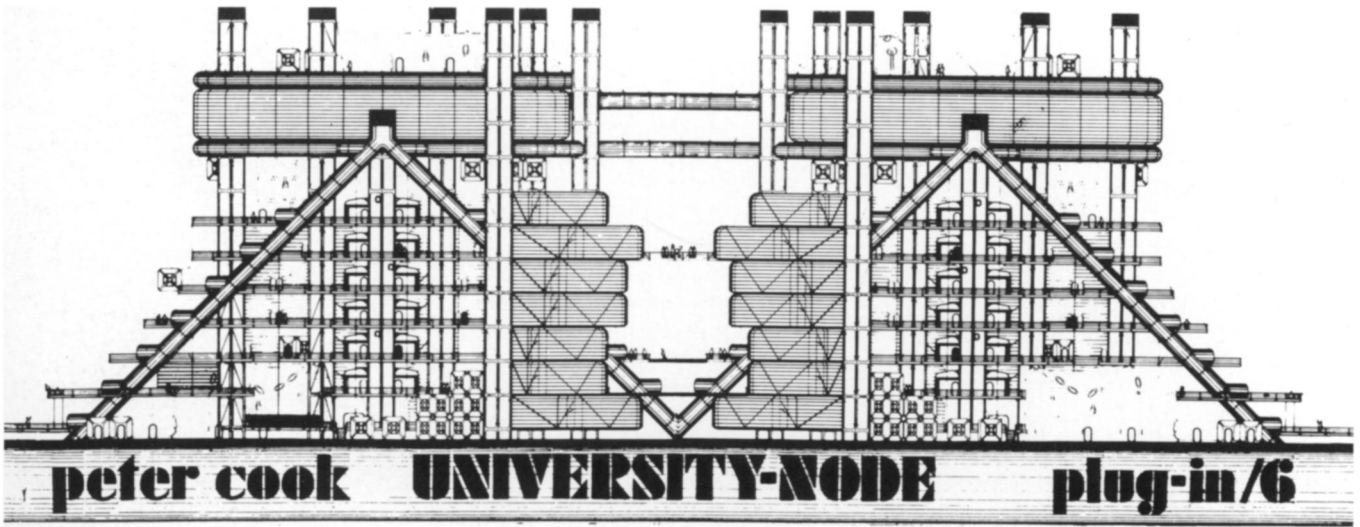

Trailmaster GTO, Transcontinental François Dallegret.

commodity, but user-designed, disposable machismo has absolutely everything in its favor. The existence of each of these traits—sexiness, disposability, and user participation in design—makes the others easier to achieve. All three are both the *raison d'être* and the result of mass marketing.

Automobiles are cheap to produce because they are an inevitable part of western culture; they are not an inevitable part of western culture just because they are cheap to produce. This is an important point. The magic allure comes first; the means of achieving it on a massive scale comes later and makes the magic easy to achieve.

The Archigram people and François Dallegret have made something of a ripple in the architectural world, not because their ideas are new, but because they clothe them in a razzle-dazzle, comic book imagery which offends many people, reminding them of oil refineries or Captain Nemo and the Nautilus. But the important thing about Archigram and Dallegret is not what their drawings look like, but the fact that they do bother to draw. Unlike most “serious” environmental systematizers, they are visual people and they know that technological breakthroughs will take place only when technology promises something that is irresistibly sexy and stylish.

Massive technical and economic upheavals do not occur in a consumer society because one product is a little cheaper or a little better or a little more available than another. They occur when a product becomes an essential ingredient of popular culture, when it becomes impossible for masses of people to live satisfactorily without it, whatever its cost—like television, or the top forty, or bell bottoms.

Automobiles are a central fixture of popular culture, and modern architecture, for all its pious sociology, has never come close. The men who design and race automobiles belong to a special pantheon of heroes for

millions of people, but the great architects of the age are like numismatists, ornithologists and other worthy but dreary experts with small and eccentric preoccupations. The designer of the Austin Mini was knighted for his efforts and to every English lad Jim Clark is a legend, but Mies van der Rohe is simply a dead man of whom he probably has never heard.

Automobiles have achieved their high cultural significance largely through two qualities which architecture characteristically lacks. Firstly, automobiles simply don't last very long. There is more labor involved in maintaining an automobile than in building it, and machine parts wear out; therefore automobiles are cheap to replace and costly to repair. Secondly, automobiles become technically obsolete fairly quickly. If houses were subjected to a full scale, aerospace style, research and development effort, they would no doubt be much improved in acoustical and thermal insulation, ventilation and plumbing; it is, however, hard to imagine that these improvements would continue in the dramatic way that acceleration, speed, cornering power and ratio of inside to outside volume of automobiles continue to improve. Thirdly, the automobile industry has been willing to exploit the obsolescence of fashion in a thoroughly cunning and audacious way. Some manufacturers like Volkswagen and Porsche righteously refrain from this sort of thing, but others create and exploit fads with utmost deliberation. Racing stripes are passé in Santa Monica this year, but flat-black hoods and big bad orange are very in, indeed.

Automobiles achieve technical excellence at low cost because there is a steady demand for them. They create and maintain a demand by being fashionable, disposable and constantly improving technically.

But because buildings are not primarily mechanisms, it is unlikely that they will continue



Jim Clark

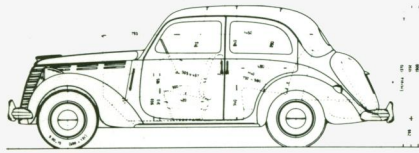
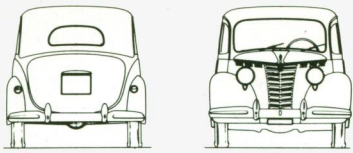

Fiat 1100, 1949-53.

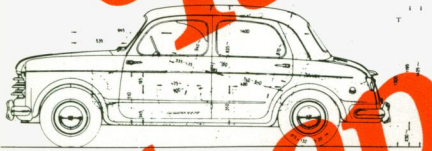
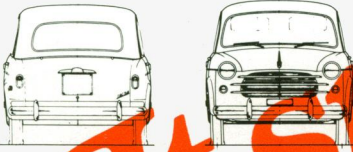

Fiat 1100, 1953-56.

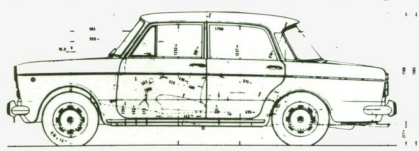
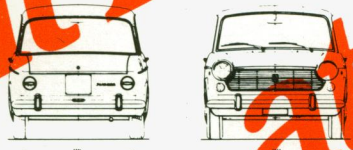

Fiat 1100, 1966-68.

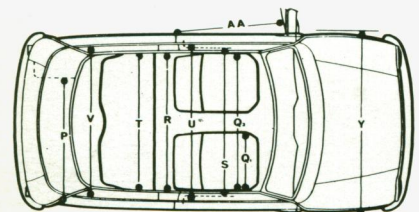
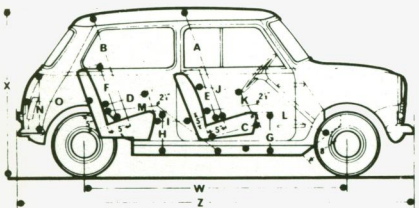

Austin Mini, 1967.

to improve as fast or fall apart as fast as cars do. It would appear then that fashion has a critical role to play in the updating of our antediluvian capacity to produce dwellings. The culture heroes of the systems movement in architecture such as Buckminster Fuller and Conrad Wachsmann were never particularly visual in their orientation. Their disciples in the schools today tend even to be antivisual and especially anti-fashion, if fashion is considered in the "Harper's Bazaar" sense of the word. At the moment, the world of inflatable furniture, super-graphics and paper dresses is very far removed from the world of industrialized building. The fads perpetrated by Detroit are often abysmally silly from a good design, modern architecture point of view, but as marketing ideas they nearly always make sense. Industrialized architecture, on the other hand, has not yet thought of marketing architectural fashion. To most orthodox modernists, it is the depths of blasphemy to suggest that the machine for living might become haute couture for living—chic, changeable, whimsical and arbitrary. There is however a powerful case to be made against the fundamentalist spirit of modern architecture and for an architecture which is as ephemeral as clothing in its design and in its substance.

It is conceivable that all three of these factors—wear and tear, mechanical obsolescence and the whims of mass fashion could be used resourcefully to create a market for industrialized building. It is not hard to imagine a home owner whose toilet ball has begun to sink, succumbing to an ad for an all new, translucent, blowformed, Sun-Blessed Home with minimal heat gain, maximal decibel loss and simulated tiger skin rugs at no extra cost.

There is a certain amount of new architecture in the world that points in this direction. It retains many aspects of modern architecture, but not the piety. It is frankly fashionable and witty and is as topical as the evening news. In part, it is an architecture

of imagery, with images not drawn from historical architecture but from current events, the movies and other sources accessible to the world at large. All of these architects are fascinated by the imagery of high technology but not in the sober manner of Gropius or Mies. Charles Moore has spoken about "generations of failure on the part of the architecture of exclusion [the modern movement] to come to grips with our own civilization and to establish a vitality of its own. . . ." One can accept this remark of Moore's without sharing his taste for Robert Venturi's super-esoteric puns on the 16th century Italian mannerism.

The Chelsea Drugstore in London has authentic vitality. It is modern; it is architecture and it is loved by more people than have ever heard of the Farnsworth House. The other projects illustrated here are done with a similar spirit. Franzen's Paraphernalia store with its architecturally scaled projections of clothing is probably the most fashion influenced space ever designed by a major architect. Electric architecture, with space defined by projections or light, is coming to be an everyday form of commercial building.

It is in the movies, however, that one can really see at a large scale, an environment which is the offspring of high technology embraced by high fashion. There are few real modern spaces with the élan and spirit of Marcello Mastroianni's apartment and the drive-in, automat brothel in "The Tenth Victim" or the lobby of the Space Hilton in "2001."

The concept of fashion in architecture is a good thing—good because it tends to make architecture a genuine part of our culture and good because it creates a market for a product manufactured by superior means. The argument here is that large scale industrialization of building, with its advantages in terms of cost and technical excellence,

*From "Plug It In Rameses, and See If It Lights Up" by Charles W. Moore; *Perspecta 11*, Yale University Press, 1967.



Space Hilton, "2001."

Apartment, "The Tenth Victim."



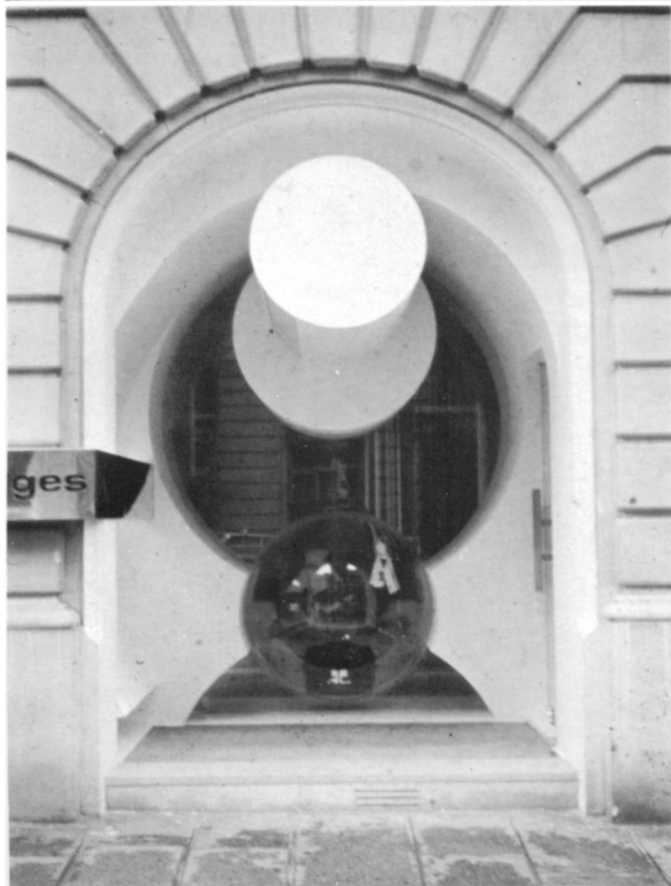
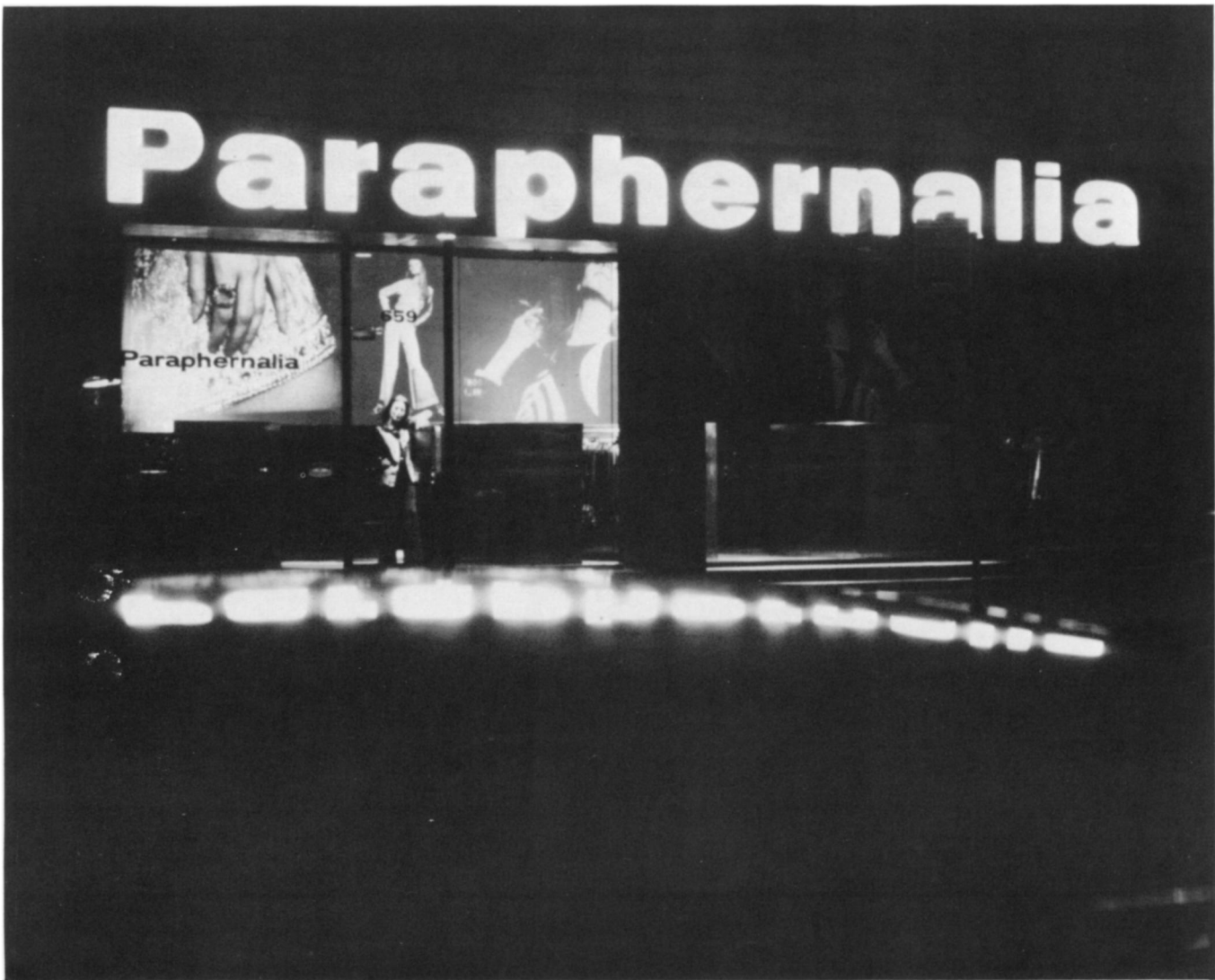

Above:

**Paraphernalia, New York.
Ulrich Franzen.**

To the left:

**Courreges Boutique, Paris.
André Courreges.**

Top facing page:

**HearHear Record Store, San Francisco.
D. & B. Solomon.**

Bottom facing page:

**Thrift Federal Savings, Concord, California.
D. & B. Solomon.**

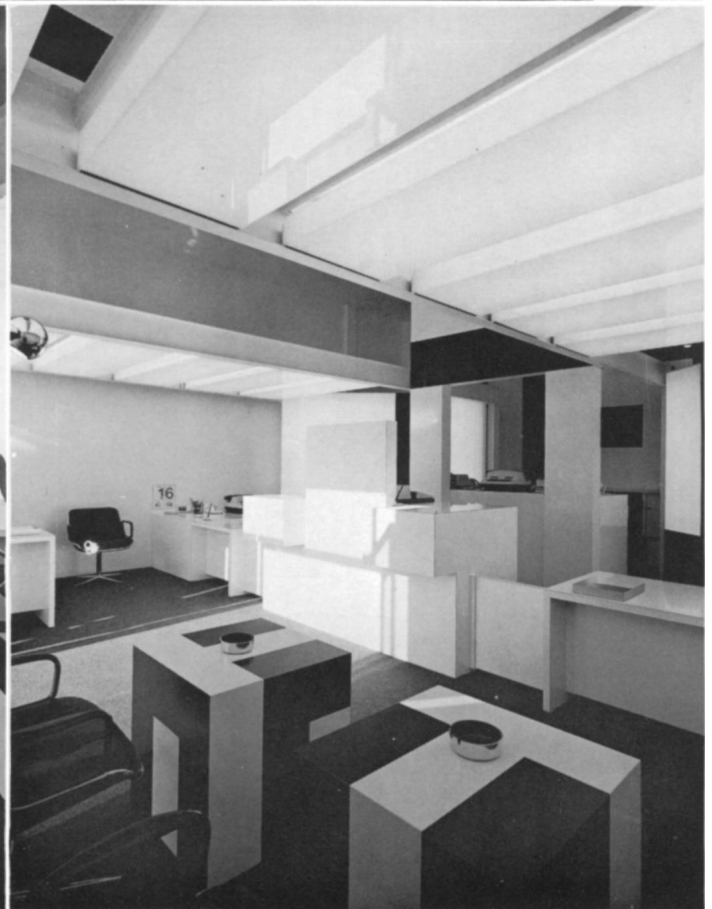
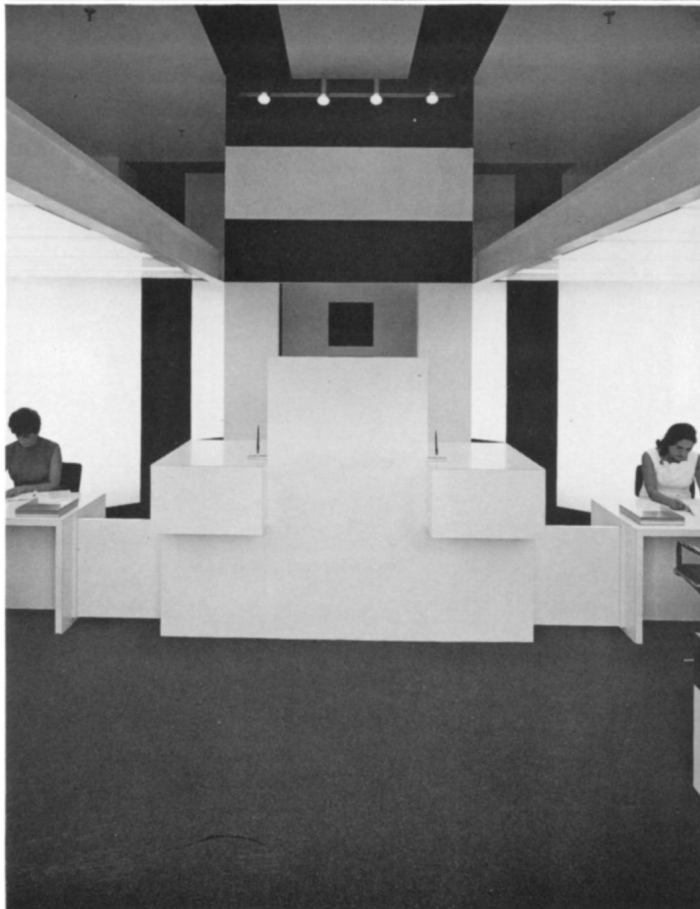
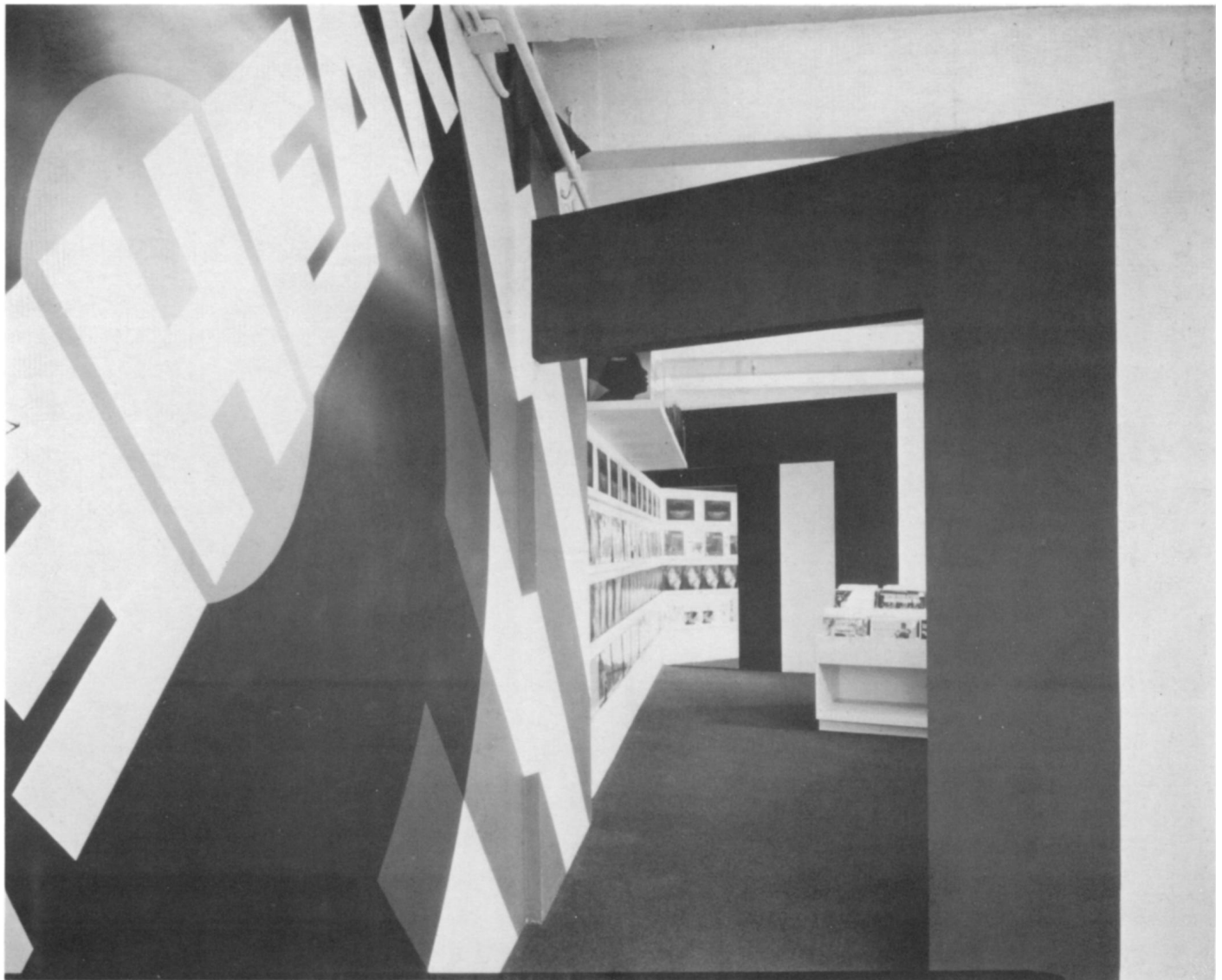



Chelsea Drugstore, London.
Garnett, Cloughley & Blakemore,
with A. Rubin of C. Albrizzi.

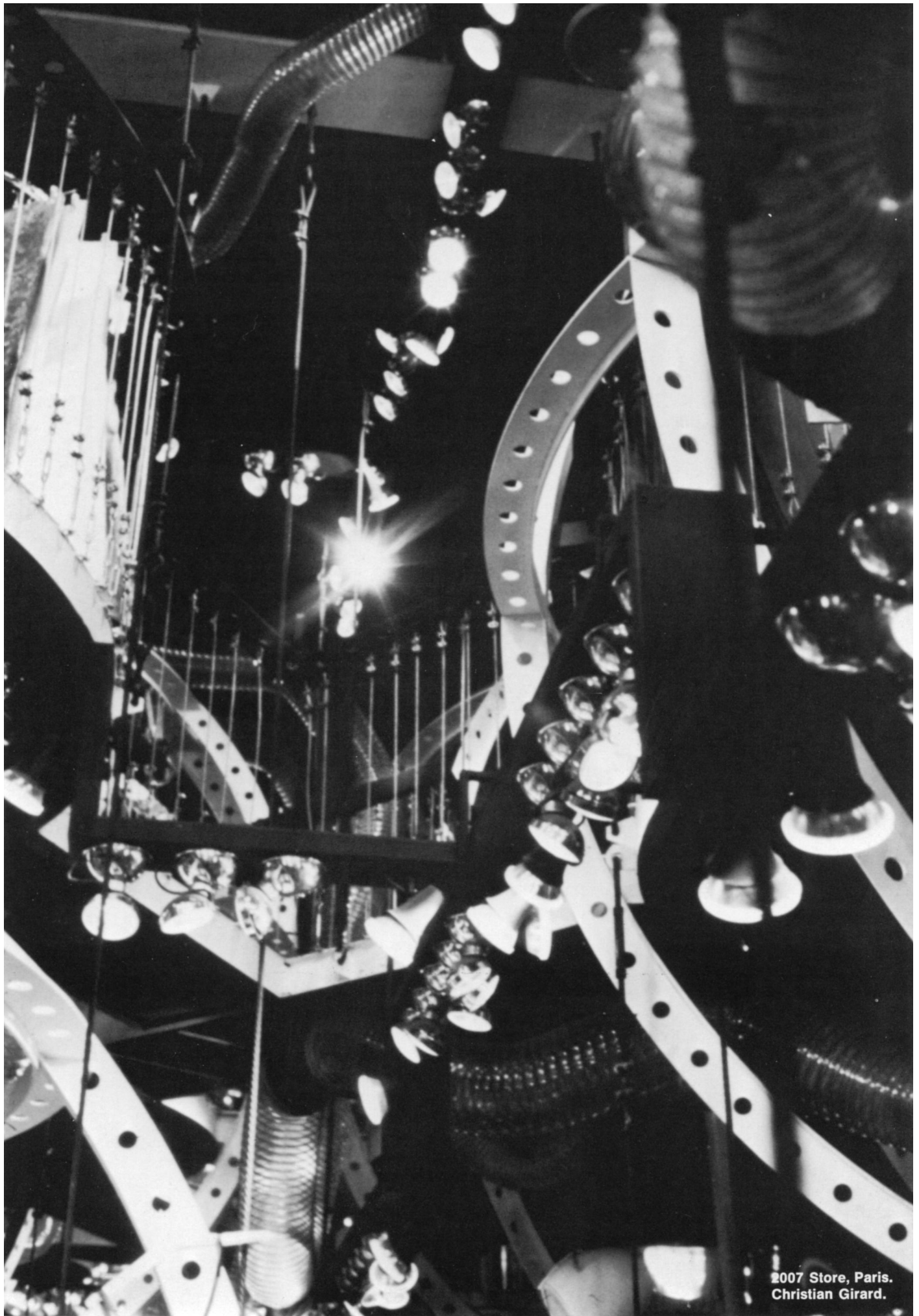

2007 Store, Paris.
Christian Girard.

can be helped by embracing the idea that buildings should be ephemeral both in design and material.

The concept of fashion is good and useful, although particular fashions may be abominable. The criteria by which one evaluates fashion in environmental design are unmysterious and no different from the criteria by which we evaluate many things.

Thus:

a 1957 DeSoto is clumsy

a Raymond Loewy airplane interior is vulgar

a colonial mobile home is silly

but:

paper dresses on TWA stewardesses are cute

and

Joe Namath's rug is just fine.



Naturally, this point of view can lead to difficulties that a Henry Dreyfus or a Gropius would never have had to face. By asking people what they want and then giving it to them, the most extraordinary perceptual errors about how things work can be fed back into the design process, contorting objects into weird, phantasmagoric shapes. Robert Osborn's drawings of automobiles are the record of

such a process. But it is interesting to note how the design of American automobiles has changed as the circulation of automobile magazines has increased and as automobile racing has become a massively popular spectator sport. Detroit may still indulge in a phony scoop or two, but the ersatz air-foils of the current super-cars are far closer to technological reality than the tail-fins of 1957.

Many planners, architects and urban designers have prognosticated a future in which the urban scene will be divided into two sectors—one more or less permanent, the other temporary. The architectural profession could reasonably be split in two. One half would deal with the permanent infrastructure: transportation, planning, big developers and the government. The other half would deal with the disposable infill: fixture design, space planning, graphics, lighting and small private clients.

The immense suburban shopping centers which have been built all over the country in the last ten or twelve years are in some ways the precursors of a great, new utopian urban form. Beneath their schmaltz and terrazzo they contain significant innovations in patterns of ownership, development, and taxation and relationships of permanent parts to temporary parts. If anything like Kenzo Tange's Tokyo Bay Scheme or the sketches of the Metabolists and the Archigram people is ever realized, it will be very different from American shopping centers in physical form, but not so different in administrative arrangement. In a typical shopping center, structural, mechanical and movement systems are in a different ownership from architectural enclosure. The center itself—the infrastructure—is intended to last a long time and is depreciated very slowly. Enclosure, graphics and appointments are changeable, more or less disposable, and subject to the whim of fashion. They are owned by the tenants, depreciated over five years or so and are normally intended to last



Fender evolution

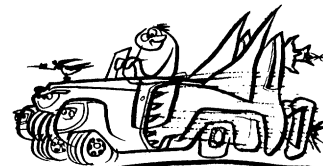

Petite grandeur

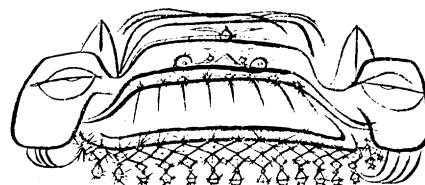

The jeweled look



The squeezer

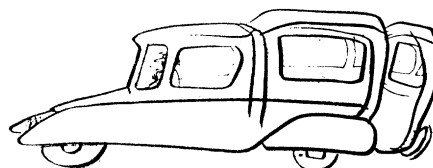
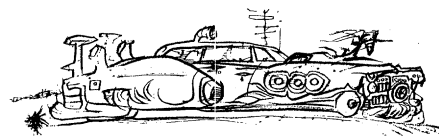

Station wagon

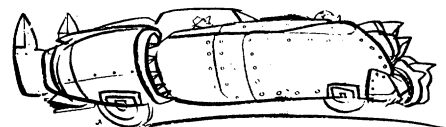

Mastodon



Flaming haunch

Robert Osborn, 1957.

Section view of an over 200 m high town system.
Akira Shibuya.

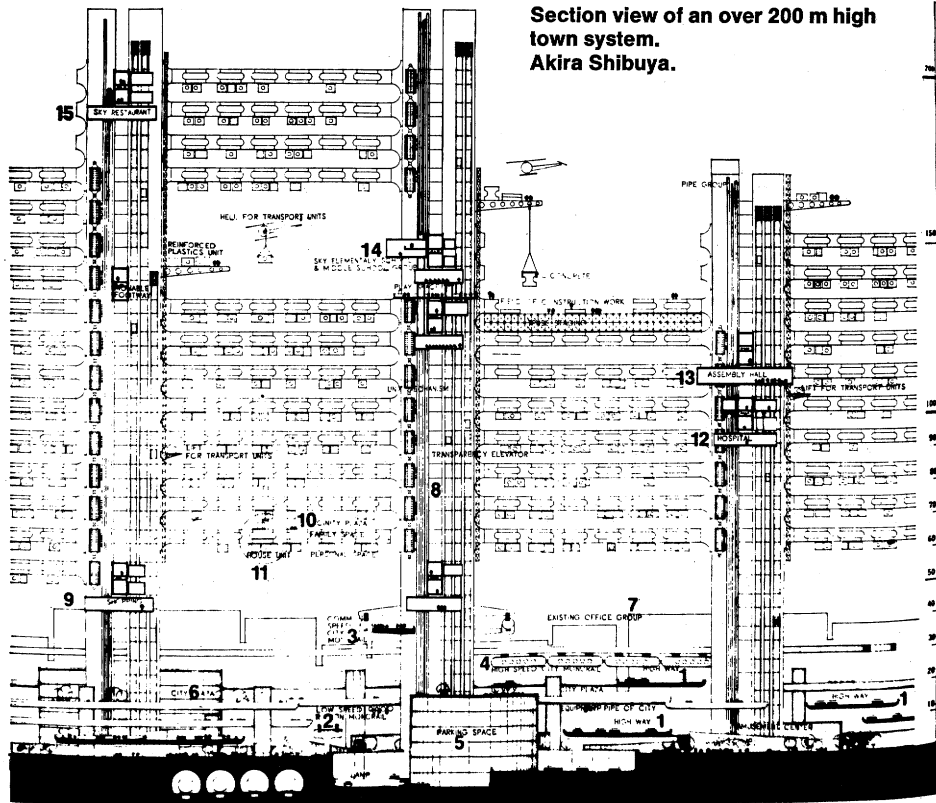

Section from Megastructure.

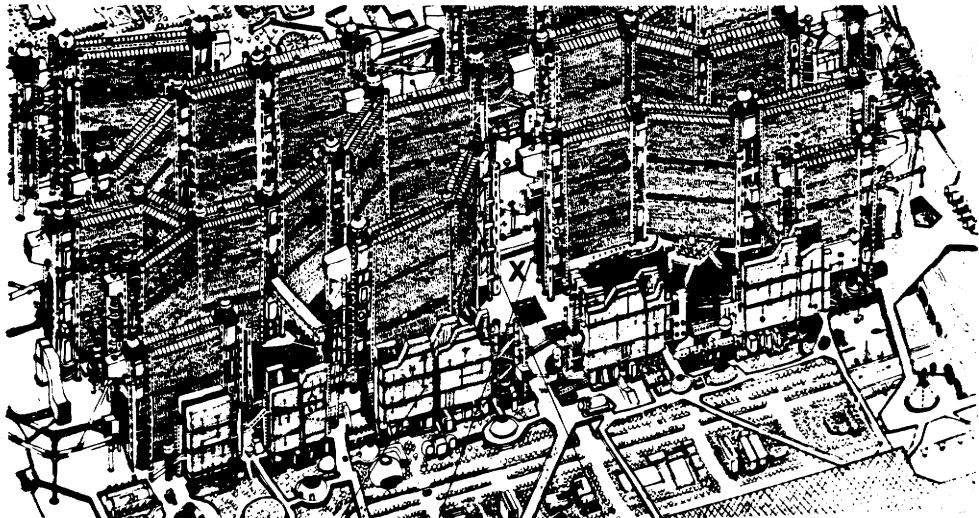
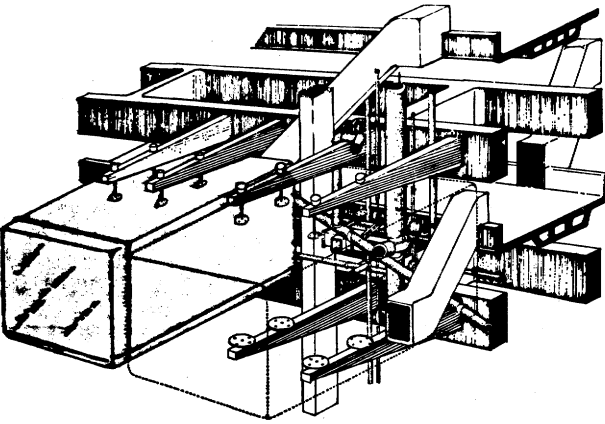
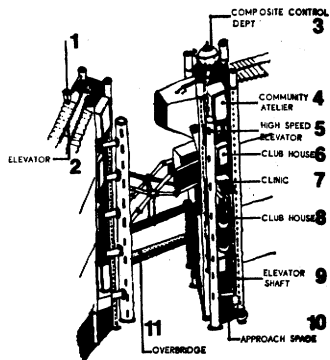

Megastructure.
Shigeo Tanaka, of the Metabolist Group.

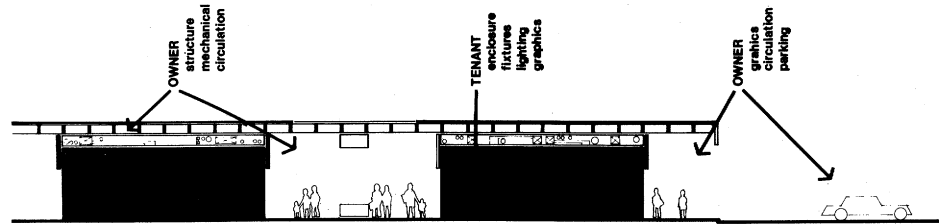

Shopping center, schematic section.

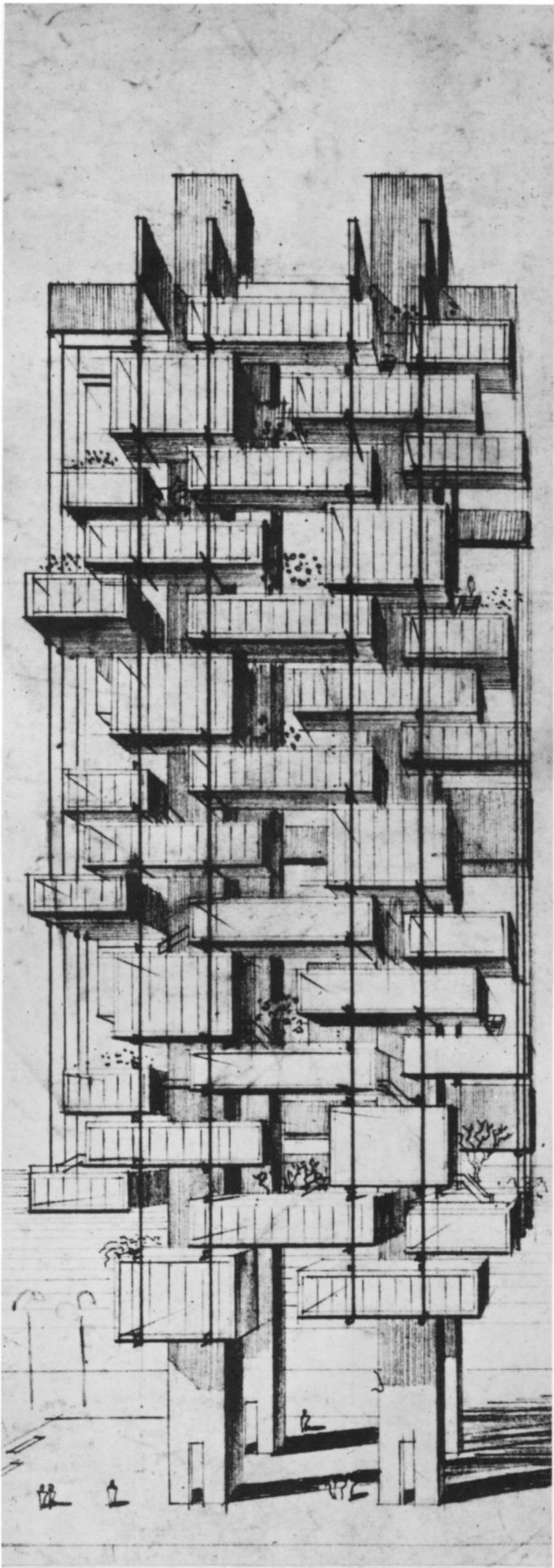

Trailer tower.
Paul Rudolph.

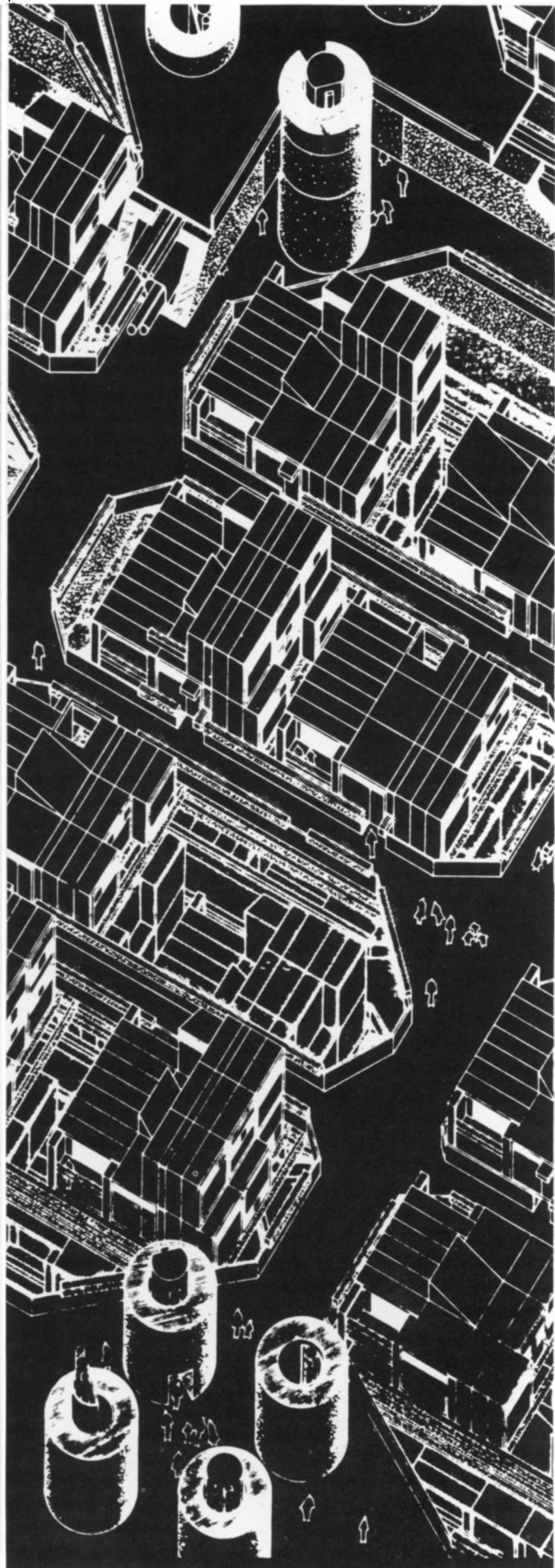

Neighborhood group.
Soichi Hata and Akira Saito.

only the length of a short-term lease. Most of the projects illustrated here happen to be tenant space in larger commercial structures. Paul Rudolph's high rise trailer park could be treated as the same administrative model applied to housing.

All of these forms—the shopping center, the high rise trailer park and the great megastructure proposals of Tange are extrapolations of a planning idea which is not new at all. For years David Crane and other planners have referred to the “capital web” as a kind of armature that organizes large-scale projects built over a period of time. The capital web is that portion of the city which is designed through public agencies and is normally in public ownership. This device permits comprehensive ordering of large environments, while still accommodating variety and change at a smaller scale and allowing the participation of many people. Typically the capital web includes streets, utilities and public transportation. In some of the schemes illustrated here it would be translated into three dimensions and include structural and mechanical systems and vertical circulation.

The Federal Government recognizes this trend and acknowledges that different components of the same building may be in different ownership and represent different types of investment. It is possible to depreciate the internal fixtures in a building in three years, the mechanical system in ten years and the structural system in forty. Internal fixtures are like personal property or equipment in a factory and therefore qualify for investment credit incentives. For people in high tax brackets disposable internal fixtures make an extremely attractive investment. Short-term financing is available through banks, with the equipment secured by a chattel mortgage similar to that used in automobile financing. Disposable items could also be owned by a leasing company, like Hertz, which could make

them available for specified periods like five years and earn interest on their investment while depreciating the objects. There is a fantastic and almost untapped economical potential in leased furniture and leased architecture.

“We are getting rid of ownership, substituting use.” John Cage.*

Small disposable objects raise the question of how and where they are to be disposed of. The styrofoam egg carton, the no-deposit, no-return bottle and other such packaging ideas have helped produce a monumental garbage problem. Disposable packaging is normally made of lightweight, chemically inert material which is difficult to burn, bury, sink or decompose and is cheaper to produce than it is to reclaim. Most cities have problems with air pollution and diminishing swill areas which are exacerbated by disposable packaging. Larger disposable objects such as furniture and buildings are more like automobiles; they are not mixed with other waste and problems of reclamation are of a different order entirely. The ecological arguments against disposable packaging would not seem to apply to large disposable objects.

In many ways an environment, large sections of which are designed to last only a short time seems like a very happy vision. A reasonable projection of the urban future might be a large megastructure, perhaps organized like Tange's Tokyo Bay scheme, with people living in inexpensive and technologically superior, plug-in environments. These environments are disposable in the way that packaging is disposable; they are produced and distributed like automobiles, administered, taxed and financed like shopping centers and are the well-loved, central fixture of popular culture that MODERN ARCHITECTURE never became.

*From A YEAR FROM MONDAY by John Cage. Published by Wesleyan University Press, 1967. Reprinted by permission of John Cage.

The Author

Daniel Solomon has, for three years, been Assistant Professor in the Department of Architecture, College of Environmental Design, University of California at Berkeley. Mr. Solomon received his A.B. degree from Stanford in 1962, Bachelor of Architecture from Columbia University in 1963 and an M.A. in Architecture from the University of California at Berkeley in 1966.

Mr. Solomon has published writings in the A.I.A. JOURNAL and projects in PROGRESSIVE ARCHITECTURE and ARCHITECTURE AND ENGINEERING NEWS. His private practice is relatively young but his work includes a number of residences, a bank, a record store and, most recently, a series of student communes.

The Graphic Designer

Barbara Stauffacher Solomon virtually revolutionized building graphics with her work for The Sea Ranch in Sonoma, California, for which she received two awards from the A.I.A. Mrs. Solomon received her B.A. from the University of California at Berkeley and pursued graduate studies at the Institute of Graphic Design in Basel, Switzerland. She has conducted design seminars at Yale University, the University of Washington, Seattle, and at the Architecture School of the University of California, Berkeley. Mrs. Solomon's design practice ranges over a large area, geographically, and includes such diverse projects as an ice rink, a record store, various urban renewal projects and continuing consulting and design programs for projects from



Credits:

For help
we wish t
Miss Mar
New York
Corporati
Christoph
Systems
Francisco
New York
(Austin-M
Longbrid
England;
Systems
Planning
Stanford,
Cook, Ar
David Cr
François
Dodge D
Motor Co
Embassy
Corporati
Fiat, Tur
Company
Photogra
Dearborn
Jacobson
Robin Mi
"Architec
London;
Times";
Princeton
author of
Japan, "I
Bauzeitu
"L'Oeil,"
Partridge
Berkeley
Yale Arch
New Hav
"Plastvä
World), H
Sweden;

design quarterly issues available: single issues \$1.60 each, double issues \$3.00. Postage and handling included in these prices.

Payment must be made in advance on all orders for back issues.

- Number 9 Outdoor Furniture and Accessories
- 10 Product Review 1949
- 11 Textiles and Designers
- 12 Lamps and Lighting
- 13 Everyday Art Exhibitions
- 14 Useful Objects / Work of Alvin Lustig
- 15 Tradition in Good Design
- 16 Tradition in Good Design: 1940-1950
- 17 Product Review 1951
- 18-19 Knife/Fork/Spoon
- 20 Contemporary Chairs
- 21 Product Review 1952
- 24 Product Review 1953
- 25 Fabric Designers and Their Work
- 26 Product Review: 20th Century Ballet Design
- 27 Five Ceramists and Their Work
- 28 Furniture Designers and Their Work
- 29 American design
- 31 Contemporary book design
- 32 Tenth Triennale Product Review
- 34 The story of Orrefors glass
- 35 Product Review 1956
- 36 Eight British designers and their work
- 37 Contemporary Finnish designers and their work
- 38 Product Review 1957
- 39 Eight designer-craftsmen
- 40 Industrial design in Germany
- 41 Product Review 1958
- 44 Product Review 1959
- 48-49 Fifty-seven American weavers and their work –
50 Art and Design in Hawaii – double issue – a salute to our fiftieth State
- 51-52 Japan: Design Today
- 53 Marcel Breuer
- 54 MacKenzie Pottery: Mendota Sculpture Foundry
- 55 Japan: Book Design
- 57 Children's Furniture
- 58 Tyrone Guthrie Theatre
- 60 Swiss Design Today
- 68 Light and Design
- 71 Mass Transit: Problem and Promise
- 72 Toward the Future
- 73 Form follows Fiction
- 74-75 Process and Imagination

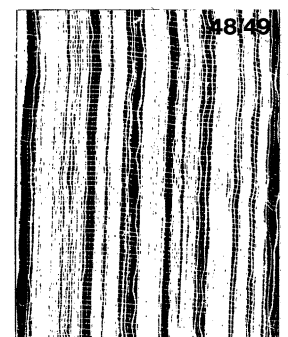
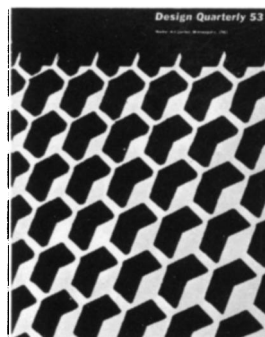
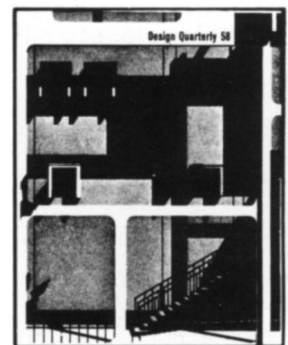
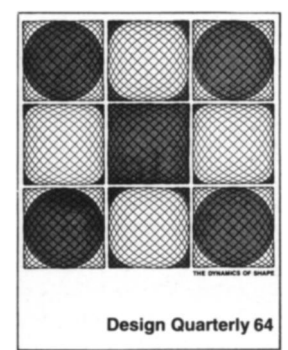
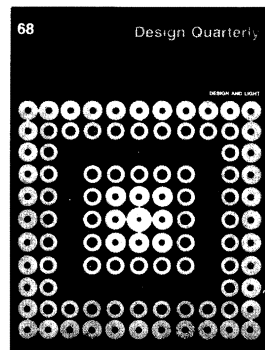
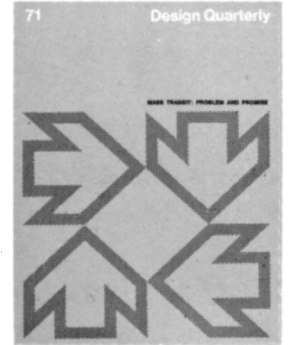
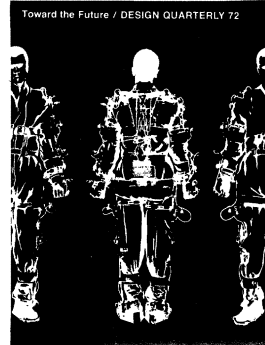
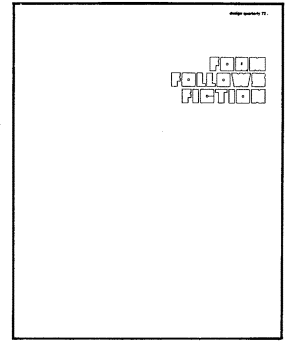

DESIGN QUARTERLY 76**Editor: Mildred S. Friedman****Graphic Design: Barbara Stauffacher Solomon****Editorial Assistant: Carol Sullivan****Circulation: Gerrie Owens**

Design Quarterly is indexed in Art Index

Subscription rates are 4 issues \$5.00, 8 issues \$9.25, 12 issues \$12.50

Single issues \$1.60, Double issues \$3.00

Foreign postage \$1.00 for 4 issues. Design Quarterly is published by
Walker Art Center, 807 Hennepin Avenue, Minneapolis, Minnesota 55403.Change of address: To insure receiving all copies, give the old address as
well as the new one and allow five weeks for change to become effective.**WALKER ART CENTER**

Minneapolis, Minnesota 55403

Martin Friedman, Director

WALKER ART CENTER BOARD OF DIRECTORS

Philip Von Blon, President

Mrs. Kenneth N. Dayton, Vice President

Martin Friedman, Secretary

Donald C. Borrman, Treasurer

Mrs. C. Merritt Case, Jr.

John Cowles, Jr.

Russell Cowles

Thomas M. Crosby, Jr.

Mrs. Julius E. Davis

Philip M. Harder

Thomas W. Jeglosky

Charles W. Johnson

Donald W. Judkins

Mrs. Malcolm A. McCannel

Mrs. Richardson B. Okie

Louis F. Polk

Henry H. Porter, Jr.

Edmond R. Ruben

William G. Shepherd

Justin V. Smith

Archie D. Walker

Walter W. Walker

George F. Waters

Fred Weil, Jr.

David M. Winton

Louis N. Zelle

Ex-Officio

Walter S. Carpenter

Hon. Charles Stenvig

Stuart W. Rider, Jr.

T. B. WALKER FOUNDATION*Trustees*

Archie D. Walker, President

Walter W. Walker, Vice President

Hudson D. Walker, Vice President

Dana C. Smith, Vice President

Justin V. Smith, Secretary and Treasurer

Mrs. Malcolm A. McCannel, Assistant Secretary
and Assistant Treasurer

Theodore S. Walker, Assistant Secretary

Mrs. Theodore S. Walker

Mrs. Willis J. Walker

Mrs. James van Loben Sels

Brooks Walker

Mrs. Wellington Henderson

Honorary Trustee

H. Harvard Arnason

Members

Calvin Goodrich

Mrs. Calvin Goodrich

Mrs. David H. Griffith

Mrs. Michael Roeder

John C. Walker

Mrs. Calvin Yeates

Miss Colleen Yeates

