

THE ORIGINAL  
RESTORATION  
MAGAZINE

50 HARD-WON RESTORATION TIPS

# Old House

JOURNAL

**BUDGET  
KITCHEN IDEAS**

5 Money-Savers  
& DIY Advice

**Updating a  
Foursquare**

**A VICTORIAN  
FARMHOUSE  
UNRETOUCHED**

**ALL-TIME  
FAVORITE  
KITCHEN  
& BATH!**

**Quick Makeovers**  
fix furniture scratches, clean  
a carpet & hang a wall frieze

**+ ICONIC CRAFTSMAN ROOM DESIGN**

PLEASE RECYCLE THIS MAGAZINE  
DECEMBER 2015

\$5.99US \$6.99CAN



12

Display until January 5, 2016

# STICKLEY STORY

Nº. 729

"When our daughter turned 21, we wanted to give her a special gift to mark her entry into adult life. Something that signified quality, strength and beauty. We thought of Stickley. The pieces we gave her are a start, and now it's a focal point in her new apartment— a reminder of how she should greet every day."  
— Charles H.





Share your Stickley Story  
at [stickley.com](http://stickley.com)

**STICKLEY**<sup>®</sup>  
SINCE 1900

Handcrafted in the USA  
for over 100 years.

OLDE  
BULLTOWN  
VILLAGE

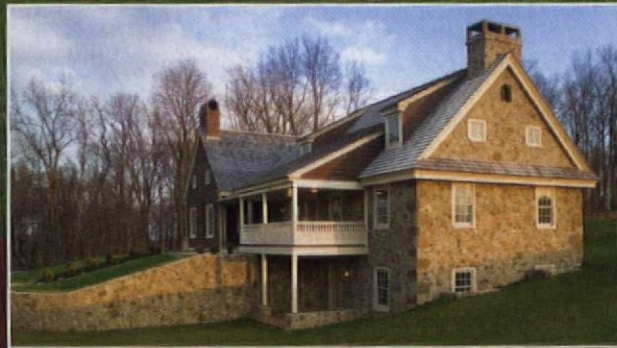
c. 1785



*Pennsylvania's Williamsburg*

THE COUNTRY'S ONLY  
NEW OLD SETTLEMENT

- Homes designed combining authentic 18th century architecture with luxurious 21st century livability.
- Regional and national winner of *Best Home* and *Custom Home of the Year*.
- Lots from the 240s  
Homes from the 800s

[OldeBulltown.com](http://OldeBulltown.com)

Olde Bulltown Village • Elverson, PA • 610.286.5115 • Conveniently located just 40 miles northwest of Philadelphia

STOLTZFUS  
EST. 1820  
ENTERPRISES LTD  
BUILDERS



For FREE information go to [www.oldhouseonline.com/lit](http://www.oldhouseonline.com/lit)



*The*  
**PERSIAN**  
CARPET

# THE ARTS & CRAFTS CARPET COLLECTION

Call for a dealer in your area 1-800-333-1801

[WWW.PERSIANCARPET.COM](http://WWW.PERSIANCARPET.COM)



PC-51A



PC-50A



# TRANSFORM

AN ORDINARY SPACE INTO AN EXTRAORDINARY ONE



Whether your project includes a new addition, historic renovation or window replacement, you can transform your living spaces to reflect your style with Marvin windows and doors. With a wide range of styles, shapes, sizes and design options, our product lines have the flexibility to provide the solution that's right for you.

Built on a foundation of values passed on through four generations, our windows and doors are an investment you will value for many years to come.

To find your local dealer and discover the possibilities visit **MarvinWindows.com**



©2015 Marvin Windows and Doors. All rights reserved. ®Registered trademark of Marvin Windows and Doors.

For FREE information go to [www.oldhouseonline.com/lit](http://www.oldhouseonline.com/lit)

# Hi-Velocity Systems™

Small Duct High Velocity Heating, Cooling and Indoor Air Quality Systems

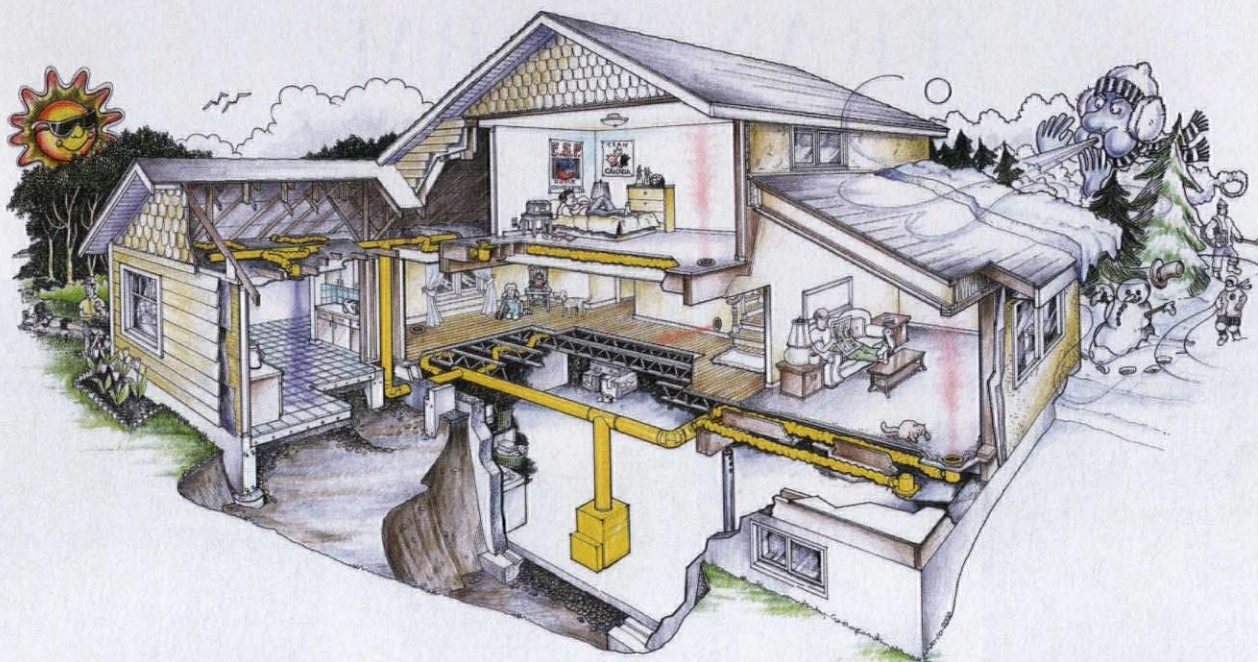

Energy Efficient Performance with No Major Remodelling

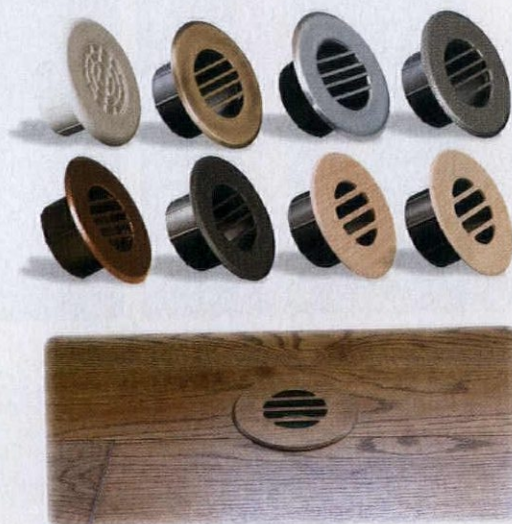

Cleaner More Comfortable Air

Energy Saving Products Ltd. - Proud Manufacturers since 1983

[www.hi-velocity.com](http://www.hi-velocity.com)

Call us today 1-888-652-2219

For FREE information go to [www.oldhouseonline.com/lit](http://www.oldhouseonline.com/lit)

— OLD HOUSE JOURNAL —

# CONTENTS

December 2015



## INSPIRE

- 12 **A Preservation Tale**  
An old farmhouse, remarkably preserved, gets a rescue.
- 24 **Tailoring a Foursquare**  
A fine 1905 house in Minneapolis is restored, and its family areas renovated for the better.
- 35 **SUCCESS!**  
In California, remnants of wallpaper and beadboard hinted at a cabin's history.
- 38 **WINDOW SHOPPING**  
Mansions under a million.



## RESTORE

- 42 **With Help from our Friends**  
A smorgasbord of 50 favorite tips and tools, culled from readers and experts, on the most popular old-house topics.
- 52 **LOST ARTS**  
Keeping a good paintbrush clean.
- 54 **QUICK MAKEOVERS**  
Three easy touchups that will make your living room ready for guests.
- 56 **STUFF MY HUSBAND SCREWED UP**  
What to do if a foot comes through your plaster ceiling.
- 58 **SALVAGE IT**  
Vintage linoleum flooring becomes a decorative wall dado.
- 60 **DO THIS, NOT THAT**  
Matching the old mortar.



## DESIGN

- 64 **Makeover for a Modest Kitchen**  
How these homeowners (and long-time contributors) achieved a bungalow-era kitchen on a budget.
- 72 **KITCHENS + BATHS**  
**KITCHEN:** Readers love this red and white mid-century kitchen.
- 74 **BATH:** The winning bath in our retrospective contest has a Victorian mood.
- 76 **VINTAGE VISION**  
Arts & Crafts living room, 1918.
- 78 **FAVORITE THINGS**  
Best sellers revealed.
- 84 **THEY STILL MAKE...**  
A magazine you may know.
- 96 **REMUDDLING**  
Fall of an Empire.



64

24

12

42

72

54

76

COVER PHOTO BY SUSAN GILMORE. SEE STORY ON P. 24.

# SIDE NOTES



## Awards, favorites, and lots to share!

This issue of OHJ is filled with reader picks, projects brought to you by jury or by popular vote, all-time favorites, and extra product coverage. Here's the background: Our house tours present award winners for the Best DIY Restoration (submitted by homeowners) and the Best Restoration by Designer (submitted by design firms or their clients). A jury of editors and contributors selected three projects in each category, which then went onto Facebook for a popular vote. The winning houses? A remarkably preserved, period Victorian farmhouse on Long Island, New York. And a stylish American Foursquare in Minneapolis with a reworked family room and kitchen.

The feature in our Restore section is a compilation of great tips, culled from readers and experts. They fall into four topic areas: Paint, Walls & Ceilings. Exteriors & Hardscape. Kitchen & Bath Remodeling. Floors & Structural Repairs. Those are the top four categories for upcoming projects reported by readers in the most recent Reader Survey. The editors added critical tools and materials.

The Design-section feature takes us to the home of Donna Pizzi and Philip Clayton-Thompson, long-time contributors to this magazine, whose own modest kitchen, shyly submitted, won kudos as the Best Budget Makeover. In a retrospective feature, we also juried favorite kitchens and bathrooms published over the years, putting them to a public vote. Our respondents adore color, as you'll see in their choice of a strawberry kitchen and a moody blue bath.

For Favorite Things, we asked colleagues in the restoration marketplace to tell us what really sells: "Send us a picture of your top seller, or your hottest recent launch," we said. You'll find some very pretty and timeless favorites here.



### LASTING EPHEMERA

I missed telling readers about contributing editor Brian Coleman's recent book on vintage paper ephemera—the packaging, postcards, advertising, playbills, labels, postage stamps, letterheads, and other “minor transient documents of everyday life.” Turns out there is a growing interest in collecting such things, for their own sake or to add a layer of authenticity and verisimilitude to a period interior. (That's how Brian got into it.) The book showcases an archival collection belonging to Cavallini & Co., who produce wrapping paper and stationery. See nicely styled vignettes, photographed by William Wright, depicting animal-themed cards, vacation destinations, flora and fauna, holidays, and maps. *Vintage Ephemera* by Brian D. Coleman, Gibbs Smith, 2014, hardcover and Kindle editions.

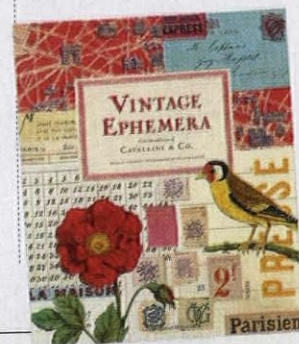

PORTRAIT BY BRUCE MARTIN



# HARBOR FREIGHT

QUALITY TOOLS AT RIDICULOUSLY LOW PRICES

How Does Harbor Freight Sell GREAT QUALITY Tools at the LOWEST Prices?

We have invested millions of dollars in our own state-of-the-art quality test labs and millions more in our factories, so our tools will go toe-to-toe with the top professional brands. And we can sell them for a fraction of the price because we cut out the middle man and pass the savings on to you. It's just that simple! Come visit one of our 600 Stores Nationwide.

## SCISSOR SUPER COUPON

# 20% OFF

ANY SINGLE ITEM

**LIMIT 1** - Save 20% on any one item purchased at our stores or HarborFreight.com or by calling 800-423-2567. Cannot be used with other discount, coupon, gift cards, inside Track Club membership, extended service plans or on any of the following: compressors, generators, tool storage or carts, welders, floor jacks, Towable Ride-On Trencher, Saw Mill (Item #1712/62366/67138), Predator Gas Power Items, open box items, in-store event or parking lot sale items. Not valid on prior purchases after 30 days from original purchase date with original receipt. Non-transferable. Original coupon must be presented. Valid through 3/3/16. Limit one coupon per customer per day.

## SCISSOR SUPER COUPON

# FREE

WITH ANY PURCHASE

### PITTSBURGH

## 1" x 25 FT. TAPE MEASURE

LOT 69080 shown  
69030/69031

### \$6.99

VALUE

**LIMIT 1** - Cannot be used with other discount, coupon or prior purchase. Coupon good at our stores, HarborFreight.com or by calling 800-423-2567. Offer good while supplies last. Shipping & Handling charges may apply if not picked up in-store. Non-transferable. Original coupon must be presented. Valid through 3/3/16. Limit one FREE GIFT coupon per customer per day.

## SCISSOR SUPER COUPON

### NEW

## 12" SLIDING COMPOUND DOUBLE-BEVEL MITER SAW WITH LASER GUIDE

CHICAGO ELECTRIC

Customer Rating **★★★★** LOT 61776  
61969/61970  
69684 shown

**SAVE \$165**

### \$134.99

REG. PRICE \$299.99

21324171

**LIMIT 6** - Good at our stores or HarborFreight.com or by calling 800-423-2567. Cannot be used with other discount or coupon or prior purchases after 30 days from original purchase with original receipt. Offer good while supplies last. Non-transferable. Original coupon must be presented. Valid through 3/3/16. Limit one coupon per customer per day.

## SCISSOR SUPER COUPON

Batteries included.

## 27 LED PORTABLE WORKLIGHT/FLASHLIGHT

LOT 67227 shown  
69567/60566/62532

Customer Rating **★★★★**

**SAVE 62%**

### \$2.99

REG. PRICE \$7.99

21291208

**LIMIT 7** - Good at our stores or HarborFreight.com or by calling 800-423-2567. Cannot be used with other discount or coupon or prior purchases after 30 days from original purchase with original receipt. Offer good while supplies last. Non-transferable. Original coupon must be presented. Valid through 3/3/16. Limit one coupon per customer per day.

## WOW SUPER COUPON

Customer Rating **★★★★**

## 26" 4 DRAWER TOOL CART

US\* GENERAL

- 580 lb. Capacity

LOT 95659 shown  
61634/61952

**\$99.99** ~~\$159.99~~ REG. PRICE \$279.99

21294364

**LIMIT 5** - Good at our stores or HarborFreight.com or by calling 800-423-2567. Cannot be used with other discount or coupon or prior purchases after 30 days from original purchase with original receipt. Offer good while supplies last. Non-transferable. Original coupon must be presented. Valid through 3/3/16. Limit one coupon per customer per day.

## SCISSOR SUPER COUPON

## 72" x 80" MOVER'S BLANKET

HaulMaster

LOT 66537 shown  
69505/62418

Customer Rating **★★★★**

**SAVE 66%**

### \$5.99

REG. PRICE \$17.99

21315460

**LIMIT 8** - Good at our stores or HarborFreight.com or by calling 800-423-2567. Cannot be used with other discount or coupon or prior purchases after 30 days from original purchase with original receipt. Offer good while supplies last. Non-transferable. Original coupon must be presented. Valid through 3/3/16. Limit one coupon per customer per day.

## WOW SUPER COUPON

## 3 GALLON, 100 PSI OILLESS PANCAKE AIR COMPRESSOR

CENTRAL PNEUMATIC

LOT 60637/61615  
95275 shown

Customer Rating **★★★★**

**SAVE 55%**

### \$399.99

REG. PRICE \$89.99

21342995

**LIMIT 4** - Good at our stores or HarborFreight.com or by calling 800-423-2567. Cannot be used with other discount or coupon or prior purchases after 30 days from original purchase with original receipt. Offer good while supplies last. Non-transferable. Original coupon must be presented. Valid through 3/3/16. Limit one coupon per customer per day.

## SCISSOR SUPER COUPON

Impressive Accuracy. Amazing Value! - Car Craft Magazine

## TORQUE WRENCHES

PITTSBURGH PRO

- Accuracy within ±4%

LOT 2696/61277

YOUR CHOICE!

- 1/4" DRIVE LOT 2696/61277
- 3/8" DRIVE LOT 807/61276
- 1/2" DRIVE LOT 62431

239 shown

21310596

**\$11.99** ~~\$29.99~~ **SAVE 60%**

REG. PRICE \$29.99

**LIMIT 5** - Good at our stores or HarborFreight.com or by calling 800-423-2567. Cannot be used with other discount or coupon or prior purchases after 30 days from original purchase with original receipt. Offer good while supplies last. Non-transferable. Original coupon must be presented. Valid through 3/3/16. Limit one coupon per customer per day.

## WOW SUPER COUPON

## 1500 WATT DUAL TEMPERATURE HEAT GUN

(572°/1112°)

drillmaster

LOT 62340/62546  
96289 shown

Customer Rating **★★★★**

**SAVE 70%**

### \$8.99

REG. PRICE \$29.99

21316738

**LIMIT 4** - Good at our stores or HarborFreight.com or by calling 800-423-2567. Cannot be used with other discount or coupon or prior purchases after 30 days from original purchase with original receipt. Offer good while supplies last. Non-transferable. Original coupon must be presented. Valid through 3/3/16. Limit one coupon per customer per day.

## SCISSOR SUPER COUPON

## 2500 LB. ELECTRIC WINCH WITH WIRELESS REMOTE CONTROL

BADLAND

LOT 61258 shown  
61840/61297/68146

Customer Rating **★★★★**

**SAVE \$90**

### \$59.99

REG. PRICE \$149.99

21291909

**LIMIT 4** - Good at our stores or HarborFreight.com or by calling 800-423-2567. Cannot be used with other discount or coupon or prior purchases after 30 days from original purchase with original receipt. Offer good while supplies last. Non-transferable. Original coupon must be presented. Valid through 3/3/16. Limit one coupon per customer per day.

## SCISSOR SUPER COUPON

## 4" x 36" BELT/6" DISC SANDER

CENTRAL MACHINERY

LOT 62502  
97181 shown

Customer Rating **★★★★**

**SAVE \$80**

### \$59.99

REG. PRICE \$139.99

21302299

**LIMIT 3** - Good at our stores or HarborFreight.com or by calling 800-423-2567. Cannot be used with other discount or coupon or prior purchases after 30 days from original purchase with original receipt. Offer good while supplies last. Non-transferable. Original coupon must be presented. Valid through 3/3/16. Limit one coupon per customer per day.

## SCISSOR SUPER COUPON

## RAPID PUMP® 3 TON HEAVY DUTY STEEL FLOOR JACK

LOT 69227/62116/62584  
62590/68048 shown

Customer Rating **★★★★**

**SAVE \$80**

Weights 74 lbs.

### \$79.99

REG. PRICE \$159.99

21323035

**LIMIT 5** - Good at our stores or HarborFreight.com or by calling 800-423-2567. Cannot be used with other discount or coupon or prior purchases after 30 days from original purchase with original receipt. Offer good while supplies last. Non-transferable. Original coupon must be presented. Valid through 3/3/16. Limit one coupon per customer per day.

## WOW SUPER COUPON

## 4000 PEAK/3200 RUNNING WATTS 6.5 HP (212 CC) GAS GENERATORS

PREDATOR GENERATORS

LOT 69729/69676 shown  
LOT 69675/69728  
CALIFORNIA ONLY

Customer Rating **★★★★**

• 70 dB Noise Level

**SAVE \$200**

### \$299.99

REG. PRICE \$499.99

21326141

**LIMIT 3** - Good at our stores or HarborFreight.com or by calling 800-423-2567. Cannot be used with other discount or coupon or prior purchases after 30 days from original purchase with original receipt. Offer good while supplies last. Non-transferable. Original coupon must be presented. Valid through 3/3/16. Limit one coupon per customer per day.

## SCISSOR SUPER COUPON

## RECIPROCATING SAW WITH ROTATING HANDLE

CHICAGO ELECTRIC POWER TOOLS

LOT 65570 shown  
61884/62370

Customer Rating **★★★★**

**SAVE 60%**

### \$21.99

REG. PRICE \$54.99

21327832

**LIMIT 3** - Good at our stores or HarborFreight.com or by calling 800-423-2567. Cannot be used with other discount or coupon or prior purchases after 30 days from original purchase with original receipt. Offer good while supplies last. Non-transferable. Original coupon must be presented. Valid through 3/3/16. Limit one coupon per customer per day.

- 100% Satisfaction Guaranteed
- Over 25 Million Satisfied Customers
- No Hassle Return Policy
- Lifetime Warranty On All Hand Tools
- 600 Stores Nationwide
- HarborFreight.com 800-423-2567



**SUBWAY CERAMICS**  
A HERITAGE TILE COLLECTION



AUTHENTICITY + CRAFT  
essential elements for timeless designs



[WWW.HERITAGETILE.COM](http://WWW.HERITAGETILE.COM)

# Old House

JOURNAL

**EDITORIAL DIRECTOR** Patricia Poore  
**MANAGING EDITOR** Lori Viator  
**SENIOR EDITOR** Mary Ellen Polson  
**EDITORS AT LARGE** Gordon H. Bock  
Brian D. Coleman  
Lynn Elliott  
Steve Jordan  
Ray Tschoepe

**GROUP CREATIVE DIRECTOR** Matthew Bates  
**ASSISTANT ART DIRECTOR** Megan Hillman  
**DESIGNER** Emily Levine

**CONTRIBUTORS** Clare M. Alexander  
Regina Cole  
James C. Massey  
Shirley Maxwell

**ACCOUNT EXECUTIVES** Becky Bernie  
Carol Murray

**ACCOUNT EXECUTIVE, EVENTS** Julia Hite

**DETROIT SALES MANAGER** Keith Cunningham

**GROUP PRODUCTION DIRECTOR** Barbara Van Sickle

**PREPRESS MANAGER** Joy Kelley

**PREPRESS SPECIALIST** Galen Nathanson

**ADVERTISING COORDINATOR** Cossette Roberts

**AD PRODUCTION COORDINATOR** Caitlin O'Connor

**SENIOR GRAPHIC DESIGNER** Michelle Miller

**DIRECTOR OF RETAIL SALES** Susan Rose

**DIGITAL ADVERTISING OPERATIONS MANAGER** Ron Goldy



**PUBLISHER** Peter H. Miller, Hon. ALA

**SALES DIRECTOR** Heather Glynn Gniazdowski

**MARKETING MANAGER** Eads Johnson

**DIRECTOR OF DIGITAL DEVELOPMENT** Josh Lewis

**ONLINE EDITOR** Kristen Hopf

**WEB DEVELOPER** Bay Tran

**DIRECTOR OF DIGITAL MEDIA** LJ Lindhurst



Pete lives in D.C. in his 1924 Sears 'Gladstone' model Foursquare. "I have double-hung windows with old wavy glass, sash chain, and weights. They need repair. Anyone know a good window person?"



ACTIVE INTEREST MEDIA

**EXECUTIVE CHAIRMAN** Efrem Zimbalist III

**PRESIDENT & CEO** Andrew W. Clurman

**EXECUTIVE VICE PRESIDENT & CFO** Brian Sellstrom

**EXECUTIVE VICE PRESIDENT OF OPERATIONS** Patricia B. Fox

**SENIOR VICE PRESIDENT, DIGITAL & DATA** Jonathan Dorn

**VICE PRESIDENT, CONTROLLER** Joseph Cohen

**VICE PRESIDENT, RESEARCH** Kristy Kaus

**VICE PRESIDENT, IT** Nelson Saenz

BUSINESS OFFICES

5720 Flatiron Parkway  
Boulder, CO 80301

TELEPHONE (800) 826-3893 EDITORIAL (978) 282-3170

BULK REPRINTS The Reprint Outsource (877) 394-7350

SUBSCRIPTION INQUIRIES (800) 234-3797

PRIVACY OF MAILING LIST:

We rent our subscriber list to reputable companies. If you do not wish to receive promotional material from other companies, please call us, toll free, at (800) 234-3797.





SAFE & EFFECTIVE



## Safe & Easy Wood Restoration

We've all been there, looking at the perfect door for a project but its paint is peeling and it's the wrong color. BLUE BEAR® Paint & Urethane Stripper safely and effectively removes multiple layers of coatings in one application. No need to sand fine millwork on the door, the gelled formulation removes paint from hard to reach places with ease. BLUE BEAR Paint & Urethane Stripper works on a variety of surfaces from wood to concrete and stone to remove latex, enamel, urethanes and even two part epoxies. Made with soybeans, BLUE BEAR Paint & Urethane Stripper is low odor and contains no hazardous chemicals. For a full line of BLUE BEAR products visit [Franmar.com](http://Franmar.com)



**Mastic & Adhesive Remover**  
for Concrete Surfaces



**Cleaner & Degreaser Concentrate**  
Replaces TSP



**Exterior Building Cleaner**



**Brush & Sprayer Cleaner**



**Saw Blade & Drill Bit Cleaner**

Call us today! 800.538.5069

Or visit us online: [www.franmar.com](http://www.franmar.com)

Find a dealer near you: [www.franmar.com/find-distributor](http://www.franmar.com/find-distributor)

For FREE information go to [www.oldhouseonline.com/lt](http://www.oldhouseonline.com/lt)



Made in the USA



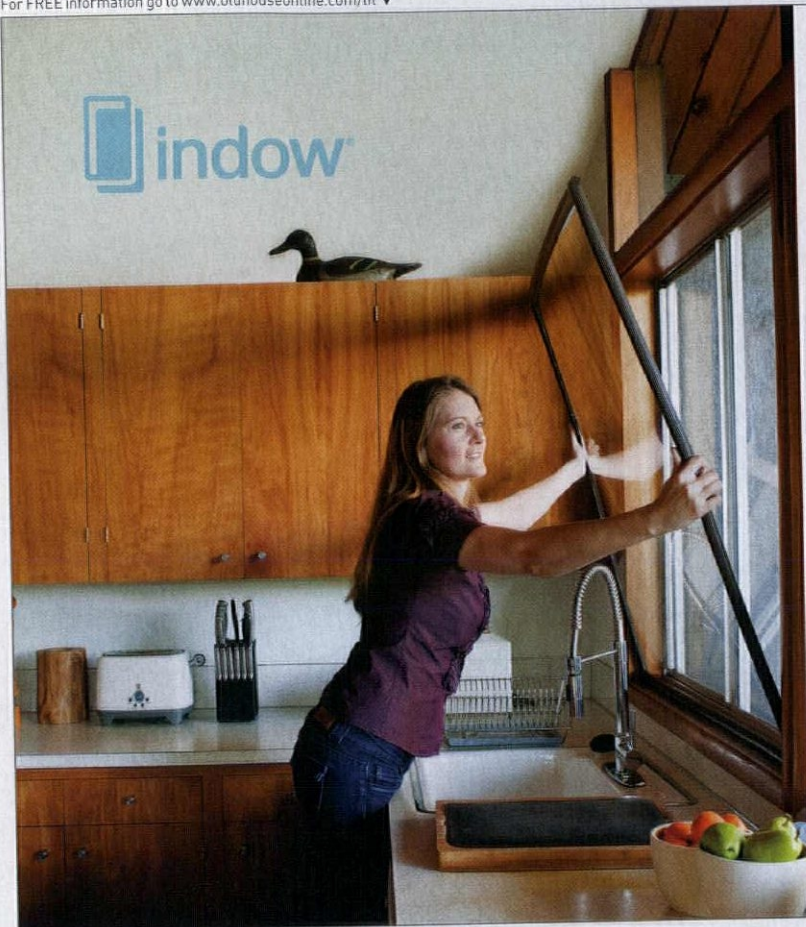

## COMFORT FOR OLD WINDOWS.

WINDOW INSERTS THAT INSTALL WITH NO MOUNTING BRACKETS.

*Keep the warmth inside.*

[indowwindows.com](http://indowwindows.com) | 503.822.3805



## Old World Charm That Complements Any Kitchen



Adorned with copper, brass, nickel or chrome, each custom built Elmira Stove Works appliance is true to its era, while offering the performance and features found in the most modern kitchen appliances.

Models available in gas, electric, dual fuel or wood-burning. Let us build one for you.

**Elmira  
Stove  
Works**  
For true originals.

[ElmiraStoveWorks.com](http://ElmiraStoveWorks.com)  
1-800-295-8498  

RANGES • WALL OVENS • REFRIGERATORS • MICROWAVES • DISHWASHERS

# Inspire



A  
FARMHOUSE  
LITTLE  
CHANGED

PAGE 12

12

## A PRESERVATION TALE

His accidental love affair with an old farmhouse and its history.  
+ VICTORIAN INSPIRATION

24

## TAILORING A FOURSQUARE

Perfecting a fine family home, built in 1905 in Minneapolis.  
+ TIMELESS CLASSICS

35 SUCCESS!: OUR DIY RUSH TO GLORY | 38 WINDOW SHOPPING: MANSIONS UNDER A MILLION



OLD HOUSE JOURNAL  
**READER  
FAVORITE**

BEST RESTORATION  
BY A HOMEOWNER  
**2015**



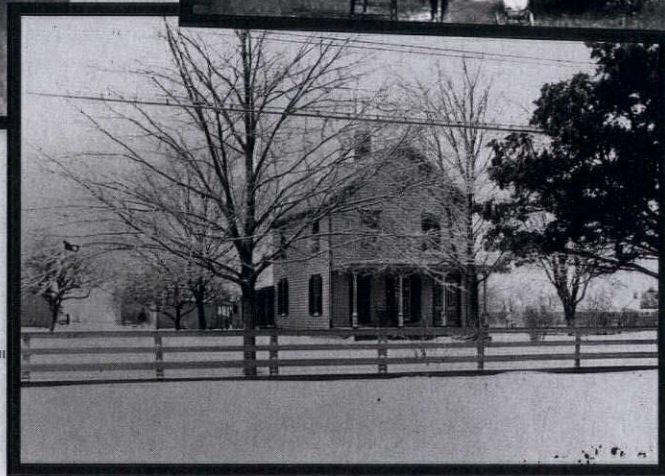

*A vernacular 1881  
farmhouse and one man's  
preservation passion*

Embued with the spirits of the original family, the Italianate house on Long Island was a relic, a sentimental gateway to a time gone by, and, for preservationist Bert Seides, an object of reverence. He restored it, largely through his own labor and by leaving well enough alone.

**BY JOYCE JACKSON | PHOTOGRAPHS BY STEVE GROSS & SUSAN DALEY**

The 1881 gable-front Italianate house is situated in the East Moriches Historic District, out on the South Shore of Long Island in New York. It had been preserved, almost unchanged, by its long-term residents, the son and daughter of the couple who built it. Bertram Seides bought the house in 1979 and renamed it Woodlawn; it would become his passion and his home.

In the year of their marriage, a mason named James Wells Barber and his wife, Sarah Terry Benjamin Barber, built the house in the area then known as Benjaminsville, after Sarah's great-grandfather, Amariah Benjamin, whose descendants owned many of the local farms. The Barber children, Lila and Raymond, never married. Ray ran a general store and was an accomplished amateur photographer; he produced many glass negatives in a primitive darkroom set up in an outbuilding that also housed the family milk cow. His photographs documented Benjaminsville's old houses and farms; he also shot humorous images of "ghosts," cats, double exposures, and self portraits. (The photographs today are part of the collections of the Center Moriches Historical Society.) Lila kept

house, played organ for the Presbyterian Church, and gave lessons on the square grand piano in the parlor. She passed away in 1979, leaving the Victorian farmhouse to a distant nephew. When Bert bought it, many Barber furnishings remained in the house.

Bert's involvement actually started with another building, a 1720 settlement cottage, in nearby Eastport, slated for demolition to accommodate widening a stretch of the Montauk Highway. "The first time I saw the cottage, I fell in love with it...no one had lived in it for years," Bert remembers. "It was covered with a gorgeous climbing rose, and crowded by massive, ancient boxwoods. I was reminded of a Wallace Nutting image. It was timber-frame construction and, like every building I take on, it was in pretty rough shape. I wasn't going to let it be lost."

The structure was stabilized, but would have to be moved. Bert bought it to save it, then looked for a property where he could "plant the old cottage. The Victorian house was on that property." His subsequent restoration of the two buildings took about ten years. A third project came along in 1989, when he spearheaded efforts to save the historic Ketcham Inn.

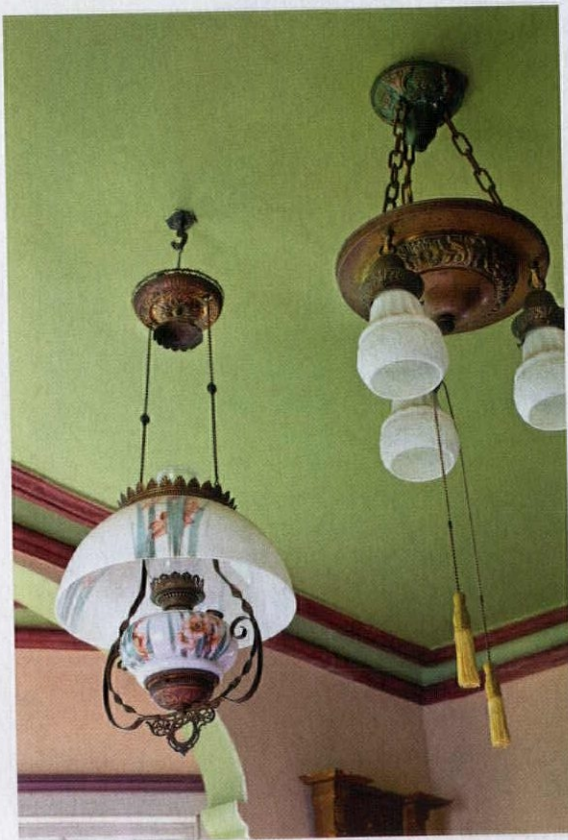

Once the parlor where Lila Barber taught piano, this cozy room is now for formal dining. The room has its original kerosene lamp and hook, along with a pull-chain chandelier added in 1910. Fir strip flooring was laid over painted, random-width pine in 1910.

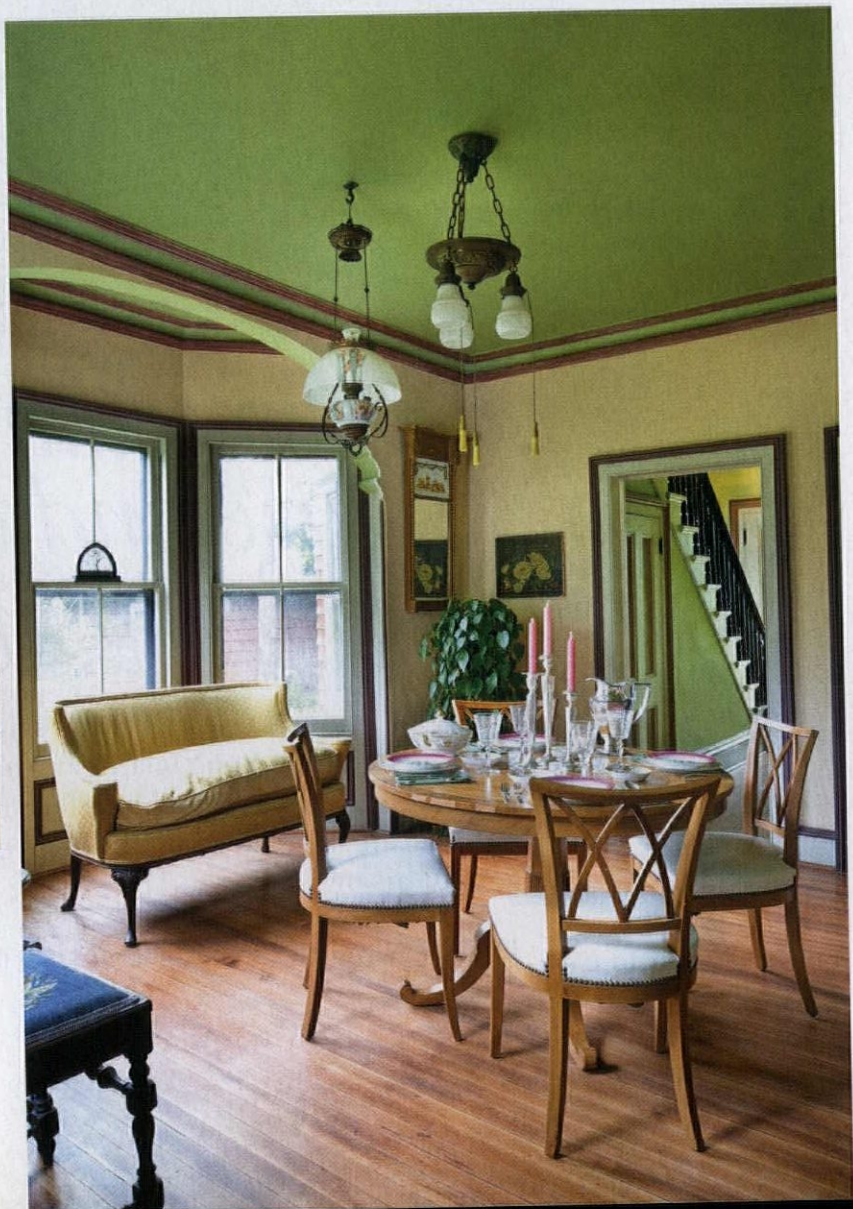





At the foot of the mahogany staircase, colorful rag rugs were made by Lila Barber (shown in the archival photo), who was the last of the original family to live here. Rugs pick up the paint colors.



## THE PRACTICE OF PRESERVATION

Bert Seides took a balanced approach that skewed toward pure preservation, but also embraced restoration (removing asbestos siding, for example) and gentle renovation (adding indoor bathrooms). His DIY tasks:

- After power-washing the exposed clapboards, Bert applied two coats of linseed oil cut with thinner, then a pigmented primer and finally the finish coats, matched to original colors.
- He rebuilt the rotted porch, saving columns and ornate brackets for reinstallation.
- He reroofed the house with cedar shingles.
- To conceal a small refrigerator and freezer, Bert built a beadboard island matching the original kitchen finishes.
- He scraped and painted plaster inside, and redid the old faux finish in a bedroom.
- Although new plumbing, heating, and electrical systems were done by pros, Bert reports he helped the electrician fish wire so plaster wouldn't be harmed.

A rare surviving example of the modern kitchen ca. 1880, the room was updated with a 1952 range.



**ABOVE:** Bert Seides found the Chambers gas stove at a Salvation Army store—in working condition. **TOP:** The cupboard was used for cool food storage; it opens both to the kitchen and back hall. The low tin-lined box was probably used to store milk. **RIGHT:** A wooden island houses the small fridge and freezer. [The marble table is temporary, destined for a visitor center related to the Ketcham Inn.]





**PAINT COLORS**

Original paint colors, now restored, remained under a coat of whitewash that was scraped off the walls.

**PLUMBING THE SINK**

The dry sink is original; a neighbor provided the vintage porcelain sink that fit perfectly inside, and running water was added.



The farmhouse was in a state of neglect. The property was densely overgrown, the barn long gone, some outbuildings in danger of collapse. The house was not attractive to any other buyers; for one thing, there was no indoor bathroom. But it was also remarkably preserved. "I removed asbestos-shingle siding to find the original paint," Bert says. "After slathering it in linseed oil, I gave the house its second-ever paint job."

Inside, many doors had only the factory coat of paint. "Once the Barbers built their house and did their color schemes, they never changed anything. It was a rare find," Bert says. "This is the most original of all the houses I've been in. It embodies Victorian architecture in its heyday. Sure, there are many Victorians in San Francisco, or Long Island, but very few that haven't been rebuilt and remodeled. I was interested in every detail of this house. I wanted to preserve what had survived."

Bert had a shoestring budget and tackled most restoration jobs himself, from nailing shingles on the roof to building a cabinet for the original kitchen. Doors and trim were left as they were. Ceilings and walls, however, needed work. Unlike most Victorian homes, this one had no wallpaper. The Barbers instead had chosen bright, bold colors done in calcimine paint. Calcimine is a water-based mix of chalk and glue binder, which later paints will not bond to. "It was a nightmare," Bert says. "I spent hour upon hour scraping, washing, and rinsing repeatedly to get rid of the chalky residue." Then he primed and painted everything in oil paint, exactly matching those original colors. "I never used a roller, but hand-brushed to get the right texture."

Other houses in the area belonging to the extended Barber family are said to be very colorful, too. (One was moved up island to the Old Bethpage Village Restoration.) "The Barbers lived here, in this house, and experienced these colors," Bert muses. Amidst his own family heirlooms, antiques, and collectibles, Bert lives with things that belonged to the Barber family: Lila's braided rugs, a table in the kitchen, Ray's quilt. A large Victorian mirror still hangs in the parlor. Lila's room holds an

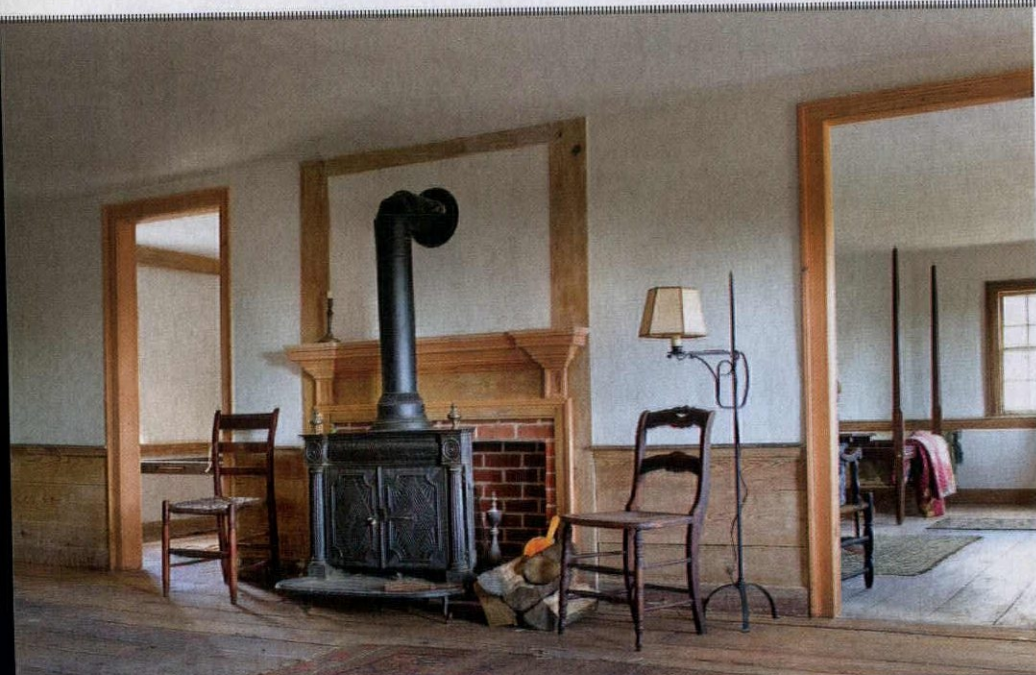

## ANOTHER PROJECT DEAR TO HIS HEART: THE KETCHAM INN

In 1989, the historic Ketcham Inn, at the heart of Center Moriches, was threatened by the wrecking ball. Bertram Seides and a group of local people launched a grassroots effort to save the building. During the Revolutionary War, Benjamin Havens ran an inn and tavern here while spying for the Patriot cause, possibly as a member of George Washington's Culper Spy Ring. It was Havens and other innkeepers who in 1772 proposed that there be a coach route (King's Highway), from

**RIGHT:** Curtain rods remain in place; the bedroom has some of the local furniture, from primitive to Victorian, collected by the homeowner. **BELOW:** In the bath addition downstairs, an antique clawfoot tub and porcelain sconces are period touches. The bed and red quilt remain in "Ray's room," where the current owner re-created the original, sponge-dabbed finish damaged by calcimine paint. **OPPOSITE:** Louvered shutters and exterior paint colors are original.



Brooklyn to Sag Harbor, which would make at stop in Moriches.

Around 1790, Havens sold the inn to William Terry; Terry's Hotel was visited by Thomas Jefferson and James Madison. Terry descendants sold the inn to Andrew Ketcham of Huntington in 1852. During the Ketcham era, the inn also was used for voting and local court proceedings; volunteer soldiers drilled on the property during the Civil War. The inn stayed in the Ketcham family until 1912. Later named the Clinton Inn, Wayside Inn, Hitching Post, Colonial Arms, and Stage Coach Stop, the inn would remain

in continuous use until August of 1989. At that pivotal moment, a destructive though contained fire set the stage for its rebirth as a landmark.

Bert received the Howard C. Sherwood Award from the Society for the Preservation of Long Island Antiquities, for his dedicated advocacy of preservation. This past Fourth of July, the building was opened to the public for the first time in many years, a living-history museum interpreting over 300 years of history here on Long Island's South Shore.

To learn more, visit [ketchaminn.org](http://ketchaminn.org)

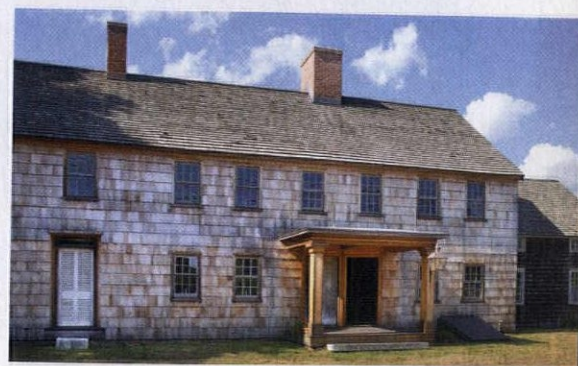

**ABOVE:** The earliest portion may date to the late 1600s. Additions followed over the next hundred years. **FAR LEFT:** The Foundation has mounted a thorough restoration of the inn, inside and out.

*Every object tells a story... shards from a dig at the Ketcham Inn, a chair found in pieces crafted from tools on display now at Winterthur.*

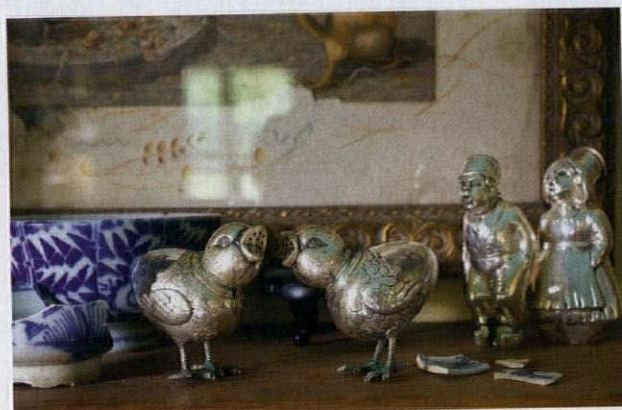

**BELOW:** The 1920s cabinet on the left is from the time when the room was an office. This owner built a matching bank to make the room a library. Visiting art-school friends painted the plaster ceiling, which had failed and was replaced. **LEFT:** Humorous antique silver salt and pepper shakers and an ancient Chinese bowl sit with fragments found under the floor of the Ketcham Inn. **BELOW LEFT:** The antique chair was in pieces in a nearby barn.



*More Online*

View more inspirational ceilings at [oldhouseonline.com/decorative-ceilings-that-inspire](http://oldhouseonline.com/decorative-ceilings-that-inspire)



The gilded picture rail is original. One remaining picture hanger prompted a search for antique tassels and cords. The lemon-silk sofa is from the Center Moriches Historical Society's museum shop. Seeing the same mantel in the double exposure of Lila, taken by her brother, Ray Barber, provokes goosebumps.

old jelly cupboard and a portrait of her father, James Barber. Ray made the sailboat model that sits in the library.

The house is rich with stories. Bert found an antique chair in pieces when he was cleaning out an old barn in Quogue. It turns out to have been made by the renowned Dominy family (active 1750–1850), from whose East Hampton workshops Henry du Pont bought 800 tools to display at Winterthur. Over the stove hangs an Eastlake-style oil lamp, original to the house but missing its fragile mercury reflector. Bert replaced it with one he'd been given when he was 12 years old.

Every repair or improvement was carefully considered. New lighting added by Bert is operated by switch, for example, but the original lights retain their pull chains. A bathroom window casing is original, unused millwork dating from the 1881 construction and found in an outbuilding. The bathrooms are the only major change to the house.

"I thought about how to add a bathroom," Bert says. There had been only a kind of attached outhouse. "I didn't want to disfigure the house, so I saw no choice but to build an addition." (It's visible to the right of the house in the photo on p. 12.) The small two-storey structure, clad in shingles, provides a bathroom on each floor. Access is unobtrusive: through a former closet door under the stairs, and from the upstairs landing. The house's original clapboards are there on one wall of the downstairs bath.

Bert was born and raised on his parent's mink farm in Center Moriches, where hired hands used to call him "the little architect." He studied architecture in New York City but remains a full-time resident of East Moriches. He serves as president of the Ketcham Inn Foundation and also of the Center Moriches Historical Society. Bert Seides is quite literally at home with history.

FOR RESOURCES, SEE PAGE 95.

# AN INSPIRED HOME

VICTORIANA AND BEYOND  
FROM AN 1880s SURVIVOR

Some old houses are like time capsules, every detail and furnishing contributing to the sense that we've entered an earlier era. Others have been subjected to unfortunate remodeling. Happily, many timeless products are still available for restoration.



## PRETTY AS A PICTURE

Paintings and mirrors hung on wire or cord from picture-rail hooks allow rearrangement without putting holes in plaster. Find everything you need from Swan Picture Hangers: hooks (\$7-12), cord (\$2/foot), tassels (\$14-38), plus medallions and decorative nails. [swanpicturehangers.com](http://swanpicturehangers.com)



## AUTHENTIC FIXTURE

Ceiling fixtures with a dropped pan and multiple lamps, popular after the turn of the 20th century, are available as antiques. This one is a reliable and accurate reproduction: the Abington, from the American Vintage Collection featuring fixtures of the 1910s and '20s. Revival Lighting, [revivallighting.com](http://revivallighting.com)

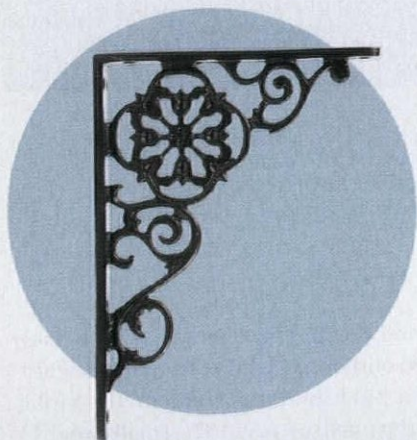

## VICTORIAN DOODLES

Shelf brackets may be made of iron or wood. Victorian brackets are more decorative and often larger than the ones you pick up at the hardware store. Van Dyke's Restorers sells several with a longer leg on the wall, for a pleasing proportion. This black iron bracket is #02037503, \$17.99 per pair, [vandykes.com](http://vandykes.com)

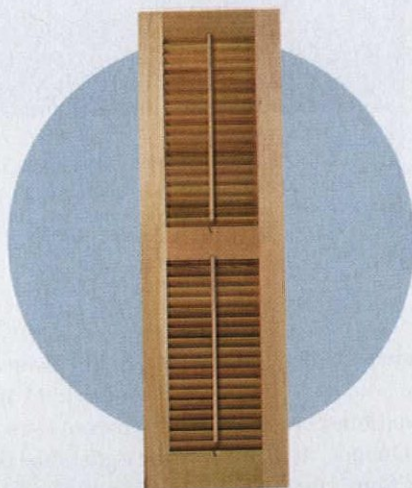

## LOVING LOUVERS

Real wood shutter-blinds, well crafted and sized to the windows, add so much to a period house. These premium movable-louver shutters in cedar or sapele mahogany, customizable, are from Timberlane, [timberlane.com](http://timberlane.com)



## NOSTALGIC KITCHEN

As original as Bert Seides's Victorian house remains (see previous story), its kitchen has layers of history. An alternative to a refurbished stove is a retro-styled new one, like the Northstar range in nine colors (electric, gas, or dual; about \$4,400). Elmira Stove Works, [elmirastoveworks.com](http://elmirastoveworks.com)



▼ For FREE information go to [www.oldhouseonline.com/lit](http://www.oldhouseonline.com/lit)

# ALLIED WINDOW, INC.

CUSTOM  
*"Invisible" Storm Windows®*

Allied Window has a strong commitment to high quality custom storm windows & the capability to meet the needs of any home or other building with single glass.

Interior & Exterior Windows  
Custom Colors,  
Custom Screens & Special Shapes  
Historic, Residential &  
Commercial Buildings  
Energy Savings—Approximately 50%  
Sound Reduction—Up to 50%



1111 Canal Road, Cincinnati, Ohio 45241 [www.alliedwindow.com](http://www.alliedwindow.com) • 800.445.5411 • fax: 513.559.1883

▼ For FREE information go to [www.oldhouseonline.com/lit](http://www.oldhouseonline.com/lit)

RAWURTH  DESIGNS

## ARTFUL

*Range Hoods*

Still handcrafted, one at a time, in the USA.



photo | Matt Olson Photography

[www.rawurth.com](http://www.rawurth.com) | [steel@rawurth.com](mailto:steel@rawurth.com)

866.932.7510



This wall of the butler's pantry (and its green paint) are original; a colonnade separates the kitchen from the enlarged family room. A wood soffit on the perimeter of the kitchen ceiling organizes the space and masks modern lighting.



OLD HOUSE JOURNAL  
**READER  
FAVORITE**

BEST RESTORATION  
BY A DESIGNER  
— 2015 —

# TAILORING A FOURSQUARE

Built in 1905 in Minneapolis, a fine family home is restored and improved by its appreciative owners along with David Heide Design Studio. **BY PATRICIA POORE | PHOTOGRAPHS BY SUSAN GILMORE**



**THE HOUSE** is a nicely detailed American Foursquare, built in the Whittier neighborhood of Minneapolis in 1905. Its Colonial Revival elements include Palladian windows, modillions and dentil mouldings in the cornices, faceted columns with carved capitals, and raised-panel wainscots inside. A few interior elements lean toward English precedent.

“The problem was the layout,” say the clients, “and the lack of sunlight. The family room, which had been a servant dining room, had great southwest light, but it was very small and isolated from the kitchen.” The growing family struggled with the back entry—just a hallway, really, with tight access and no place to stow coats. The rear of the house, pocked with a closed-in but unheated porch, needed to be cleaned up.

So designer David Heide and his project architect, Chris Christofferson, were retained to add family space, rework the

kitchen, and create a rear entryway with a powder room. “We wanted rooms to look original,” say the clients, something the designers accomplished by repeating existing elements and looking toward historical precedents. A space-dividing colonnade matches newel posts on stairs and columns on the front porch. Other repetitions are found in art glass, the diamond motif (on the original façade, now incorporated in the range hood), and the paneled wainscoting. Salvaged elements contribute to the seamless look: wainscots, the medicine cabinet and pantry sink, and many of the light fixtures came from remodeled areas of this house.

The new addition, along with the restored second floor at the rear, are clad in wood clapboards. The intention is to restore clapboard siding to the entire house, which was covered in cedar shingles at some time in the past.



The 1905 American Four Square is nicely detailed with classical cornices, faceted porch columns, and diamond motifs. The owners earlier restored the porch and porte cochere with reference to a historic photo supplied by a neighbor. The addition re-organized the rear facade, where now a covered porch leads to the back entry door.

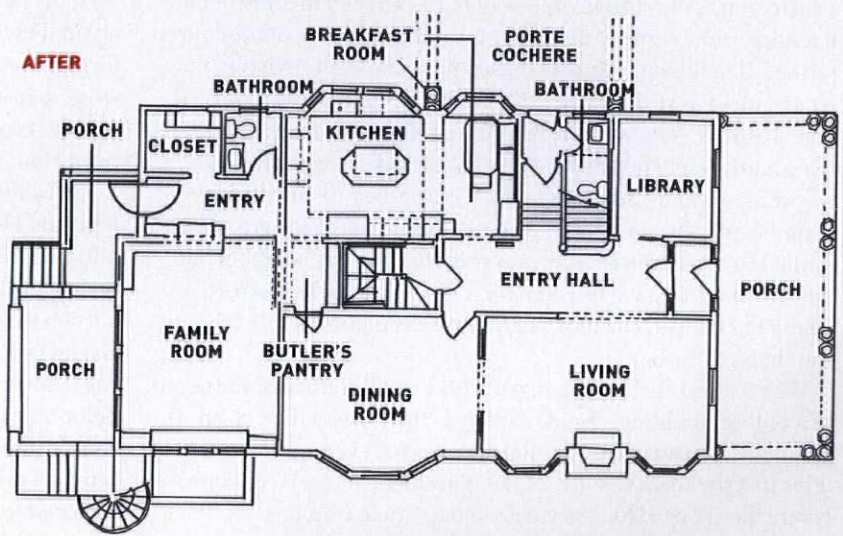
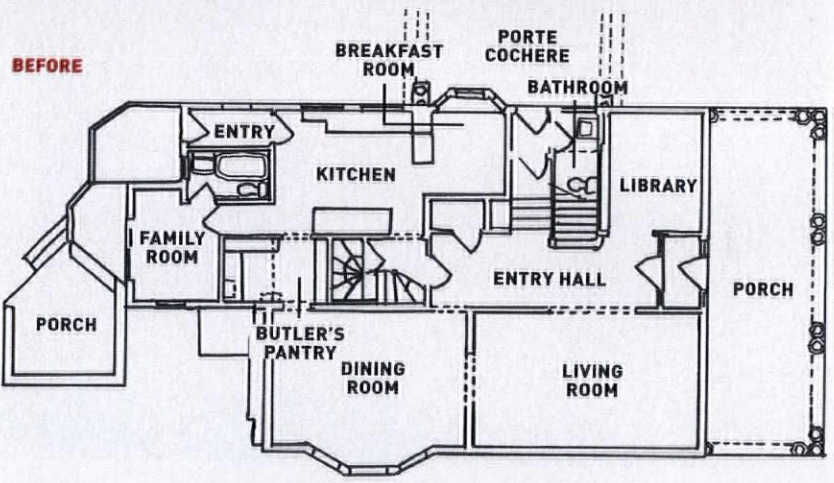
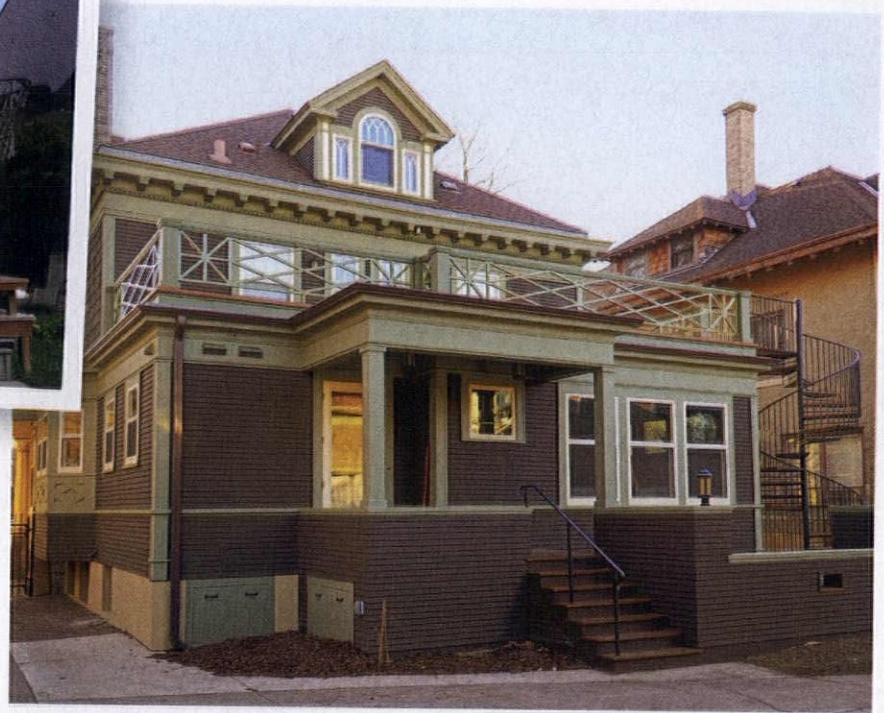

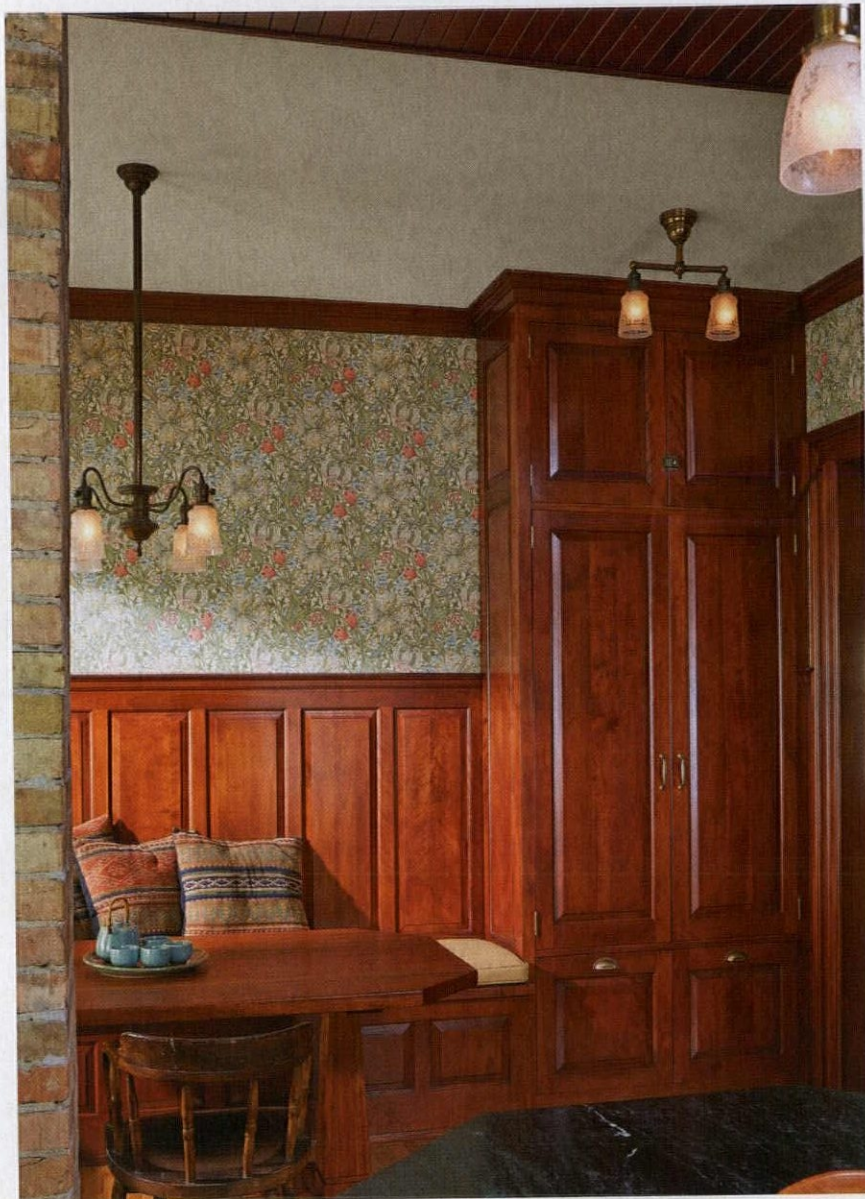

**PERIOD CONVENTIONS** followed in the kitchen include plain, flat-edge white subway tile with grey grout and soapstone countertops. Traditional cabinets (based on those in the existing butler's pantry) were designed with flush inset doors and exposed barrel hinges. New wood is red birch, finished with aniline dye and shellac. The clients' wish list included a center island, accommodated by bumping out a window bay 10' for the sink counter. "We elevated the windows," Heide says, "to screen cars parked in the driveway and gain privacy from the neighboring house—and that gave us room for a historical backsplash." The island has clipped corners, facilitating circulation while echoing the shape of the bay.

"The ceiling is better organized with a small soffit, just the depth of a ceiling moulding," Heide explains. "It creates a nice, clean rectangle, instead of a plane that jogs around every cabinet." He adds that the shallow soffit allows placement of recessed lamps where they're needed, regardless of the ceiling framing.

In the butler's pantry, the green-painted cabinets that remain are in their original location. The space was in a prime corner, facing south and west: "a bad place to store pantry items in the sun!" says the owner. The butler's sink was removed to the new powder room, and several cabinets relocated as built-ins in the newly finished basement.

"We didn't want to entirely remove the pantry, but it blocked light and also access between kitchen and family room," Heide adds. He kept the interior wall of cabinets and created an open wall opposite for sight lines between rooms.

"We embraced the particular shade of green that runs through the house," Heide says; the owners weren't interested in changing it, or stripping it from woodwork in other rooms. Now the color repeats in the big entry closet and the powder room. DHD Studio interior designer Michael Crull helped the clients assimilate their antiques and family pieces—the husband is from England—and choose finishes for rooms. "English Morris & Co.



## PHILOSOPHY IN PRACTICE

David Heide Design Studio is a full service architecture, interior design, and historical restoration firm in Minneapolis. The firm's motto is "honor the past while anticipating the future." Much of their philosophy is apparent in the renovation of this Foursquare:

- For any additions, scale is carefully considered to honor original massing and character.
- Existing elements inform new work; here, that included repeating original details and motifs in paneling, trim casings, baseboard, etc.



- Original and vintage materials find their way into renovation. Here, that included the old butler's sink re-purposed in the new powder room, and the use of antique lighting.

- New work alludes to historical precedent; for example, the desire for well-lit, open living spaces was mediated by the use of a colonnade.

"It always gives me pause when we elevate 'back of house' areas to 'front of house' standards of luxury or style," David Heide says. "I talk myself through it by understanding that the 'front of house' people—the homeowners—are now the ones using the kitchen and rear entrance. That said, we nod to tradition by making minor changes, like the use of a different wood species for public vs. family rooms."

For more on their design process, go to [dhdstudio.com/process](http://dhdstudio.com/process)

**ABOVE:** Chris Christofferson & David Heide. **TOP:** Mimicking bay windows in the original house, a bump-out bay added just enough room in the kitchen. The island has cutaway corners to ease circulation around it. **OPPOSITE:** With its original paneled wainscot, this space had been opened to the kitchen during a previous remodeling; new built-ins include the table and bench and a tall pantry cabinet.

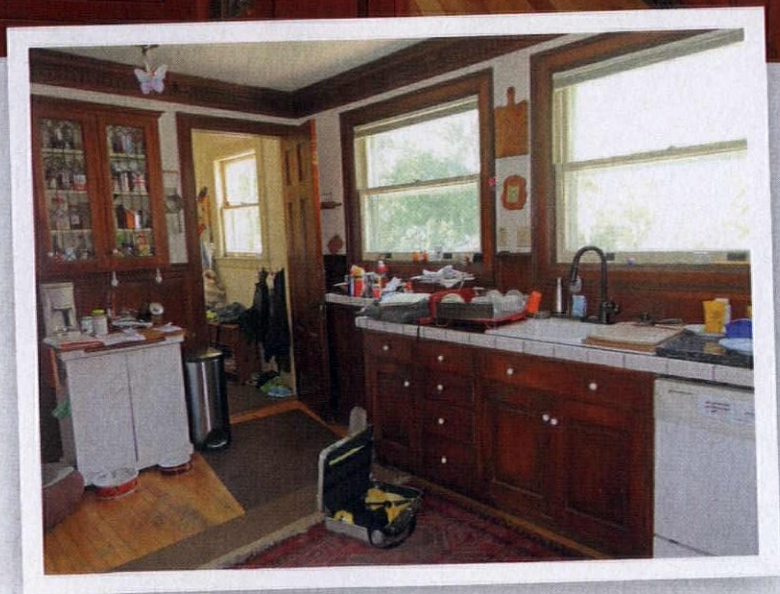



### More Online

Mudroom design basics at [oldhouseonline.com/design-traditional-mudroom](http://oldhouseonline.com/design-traditional-mudroom).

wallpapers work well with that green,” Crull says. [‘Weekend Getaway’ #473, Benjamin Moore]

Extending behind the original dining room, the family room is in a new addition at the rear of the house. “You have to think about the view between rooms,” Heide says. “Looking toward the kitchen, you don’t want to see blinking green microwave clocks and stainless-steel appliances, but rather cabinets, light fixtures, lovely wallpaper.”

Nearby is the organized family entryway off the rear porch. Rather than a mudroom “that you walk through, dropping your junk along the way,” Heide jokes, “we created a back hall with just a built-in storage bench and a full-length mirror—and a separate, walk-in closet behind a door, with stacked shelving and a bank of drawers. Guests don’t have to climb through hockey sticks and violin cases on the way to the back deck.”

A powder room next to the closet, easily accessible from the back door, is screened from view of the kitchen. Wall-mounted faucets worked best with the reused materials and width of the room. Combination gas/electric sconces are salvaged antiques.

Although the family areas at the rear of the house have a more open plan—and lots of sunlight—the scale and hierarchy of rooms have been maintained. “The family room connects to the dining room,” says the homeowner, “and both make a seamless transition into the kitchen and more formal living room in the front of the house. Entertaining is so much better now.”

**BELOW:** The informal family room is in the new rear addition; the dining room at left in the photo is part of the original footprint. **RIGHT:** The back entry has a well-organized walk-in closet in lieu of a mudroom. **OPPOSITE:** The powder room boasts the repurposed “German silver” butler’s sink, gaslight-era sconces, and Morris & Co. ‘Compton’ wallpaper.







# TAILORED CLASSICS

A MIDWEST FOURSQUARE  
INSPIRES A TIMELESS LOOK

The 1905 Minneapolis house is a Colonial Revival classic—columns and Palladian windows—but with English and Arts & Crafts hints. Stylized foliate patterns, brass and glass hardware, and natural materials like stone and hardwood are perfect complements, as popular now as when the house was built.



## COMPTON AS A TEXTILE

The Compton design (Dearle for Morris & Co., 1896) was first a wallpaper, then a textile. Buy ready-made pillows in Compton fabric through Zazzle. Cotton with a hidden zipper; shown, 16" pillow, \$41.95 with other sizes available. [zazzle.com](http://zazzle.com)



## CLASSIC REVIVAL HARDWARE

Like subtle jewelry, hardware adds the finishing touch to doors and kitchen cabinets. House of Antique Hardware has a vast selection of high-quality yet affordable knobs, bin pulls, old-fashioned latches, and more, in many materials and handsome finishes. [houseofantiquehardware.com](http://houseofantiquehardware.com)



## DON'T FORGET YOUR MUNTINS

Diamond-pane windows are original to the 1905 Foursquare; new windows were custom-made to match. Andersen Windows' 400 Series Woodwright Double Hung line shows muntin patterns in diamond,  $\frac{3}{4}$ , short fractional (top row), Prairie crossed corners, and custom options; seven colors and seven exterior trim profiles. [andersenwindows.com](http://andersenwindows.com)

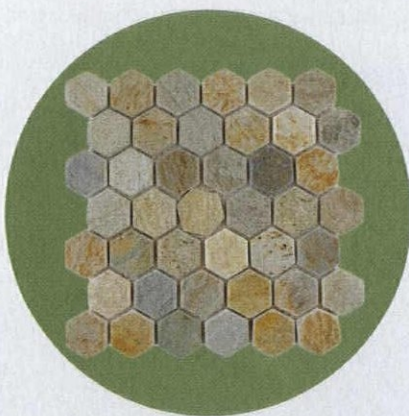

## SOFT STONE HEXES

For the Foursquare house's rear entry, David Heide Design specified these beautiful yet hard-working slate hexagons, 1½", in the soft Tumbled finish. The colorway is Desert Sand. Uninstalled, approx. \$14.25/sq.ft. Akdo, [akdo.com](http://akdo.com)

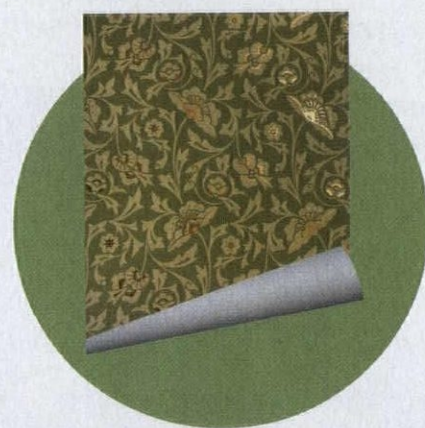

## IN THE MORRIS TRADITION

William Morris and compatriots like Christopher Dresser created the English Aesthetic and Arts & Crafts movements; Morris papers, still available to the trade through Sanderson, have been in style for 150 years. This Aesthetic design by Dresser is called Persia, produced today (\$57 a roll) by Mason & Wolf, [mason-wolf.com](http://mason-wolf.com)



Authentic vintage fixtures & handcrafted reproductions.



Over 800 items on our website. New items added weekly.

[PWVintageLighting.com](http://PWVintageLighting.com)

1.866.561.3158 2 State Rd., Gt. Barrington, MA 01230



Entry Door Mode

Screen Door Mode

**CHRISTIE'S**  
*Wood and Glass*

**America's Answer to the Dutch Door - *The Breeze***

Phone: (970) 385-9066  
Toll Free: (877) 371-8894  
1166 S Skylane Dr., #2  
Durango, CO 81303-6003  
[christies@entryways.com](mailto:christies@entryways.com)  
We Ship Nationwide

Visit our "Gallery with Pricing" at:  
[www.breezedoors.com](http://www.breezedoors.com)  
Or  
Examine our vast portfolio of custom entryways at:  
[www.entryways.com](http://www.entryways.com)

**WEST  
SYSTEM**

Repair and  
protect the  
irreplaceable.

Waterproof epoxies  
for wood, metal,  
fiberglass and more.

[westsystem.com](http://westsystem.com)



For FREE information go to [www.oldhouseonline.com/tit](http://www.oldhouseonline.com/tit) ▼

**Your Best Source for Victorian Hardware and Lighting**



**Vintage Hardware & Lighting** [www.vintagehardware.com](http://www.vintagehardware.com) 360-379-9030

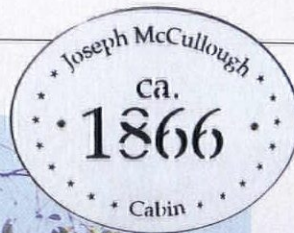

## OUR DIY RUSH TO GLORY



Did remnants of Victorian wallpaper and a beadboard ceiling hint that the cabin dated to gold-rush days? **By Andy Carpentier**

**Rooms inside were dismal**, but the little cabin perched above the gold-mining town of Sonora, just an hour from Yosemite, had potential. We were won over by the asking price—and a suspicion that the cabin was actually historic. Our first years here had us removing 1950s accretions while we did research. We found a 1954 newspaper in a wall, marking the date of modernization, when studs were added to plank walls to conceal pipes and wires. Plywood paneling, dark and flimsy, was added, and acoustical tiles dropped the ceilings 18". We removed all that, along with sheet flooring and Masonite, to reveal aspects of the original cabin: fir plank floors and painted beadboard ceilings. Once restoration began in earnest, it took three years. New systems were added, walls insulated. We decided on beadboard for most wall surfaces, echoing the old ceilings; today's material is the same as it was 160 years ago. Here and there, we framed remnants of old wallpaper, left on walls to preserve the historical record.

We added a central heat pump and ductwork below the floor. This new system provides each room with heating or air conditioning through vintage, round, cast-iron floor registers. A programmable thermostat was recessed in the wall, concealed behind a framed period photograph. Vintage light fixtures were rewired and push-button wall switches installed. We are the 14th owners of this property, and we won't be the last.

*Andy Carpentier is a senior architect with YHLA Architects in California.*

### UNCOVERING HISTORY

Listed with a build date of 1949, the cabin revealed a much earlier history.

- Property and tax records at the historic courthouse revealed that an original, gold-rush era cabin was destroyed by a fire in 1861, along with half the town.
- The first recorded property owner, one Joseph McCullough, built a two-room cabin on the site around 1866.
- A subsequent owner tripled its size in the early 1870s.
- A prominent local family purchased the cabin in 1887—and rented it out until 1952.
- A 1954 newspaper found in the wall marks the time when new owners modernized the house.

**ABOVE:** The quaint porch overlooks the town of Sonora, Cal. Double-glazed fir windows replaced aluminum versions from a previous remodeling. This owner's only addition has been a small, screened sleeping porch, accessible through French doors from the two bedrooms.



Inspire  
**SUCCESS!**



**FROM LEFT TO RIGHT:** Gone is the dark 1950s paneling; insulated walls now are mostly clad in beadboard. Hollow-core doors were replaced with fir five-panel doors with period rimlocks and porcelain knobs. The galley kitchen is supplemented with narrow work tables. An indoor bathroom was a must; the owners chose simple, sturdy tile, fixtures, and finishes familiar a century ago.



For FREE information go to [www.oldhouseonline.com/lit](http://www.oldhouseonline.com/lit) ▼

We're  
putting  
a new  
twist on  
aluminum.





[www.ultrafence.com](http://www.ultrafence.com)

Now, your wrought  
fencing, railing and  
gates can be handsome,  
historic and built to last.

 Our metals and coatings are  
chosen first for their endurance.

All Estate Collection gates, railing and fencing are constructed of strong aluminum alloys, powder-coated with a durable layer designed to withstand punishing weather and the effects of time—conditions that cause ordinary metals to rust, corrode and crumble.

The Estate Collection by Ultra Aluminum Mfg. is crafted on a series of CNC machines designed by European blacksmiths to twist and turn the metal into intricate designs and shapes that far exceed the light-weight aluminum fencing you see at local lumber yards and home center stores.

The treatment of the metal can replicate all the nuances and fine scrollwork we found in the iron fencing that was hand-hammered long ago, plus a few new twists. There is virtually no limit to the composition and construction of the gate or fence. Visit [www.ultrafence.com](http://www.ultrafence.com) for details.

*Estate  
Collection*  
FINELY CRAFTED  
GATES, RAILING & FENCE



Inspire

WINDOW SHOPPING

## Grandeur Under a Million

Each built by a millionaire many years ago, these five historic mansions can be yours for less than seven figures today.

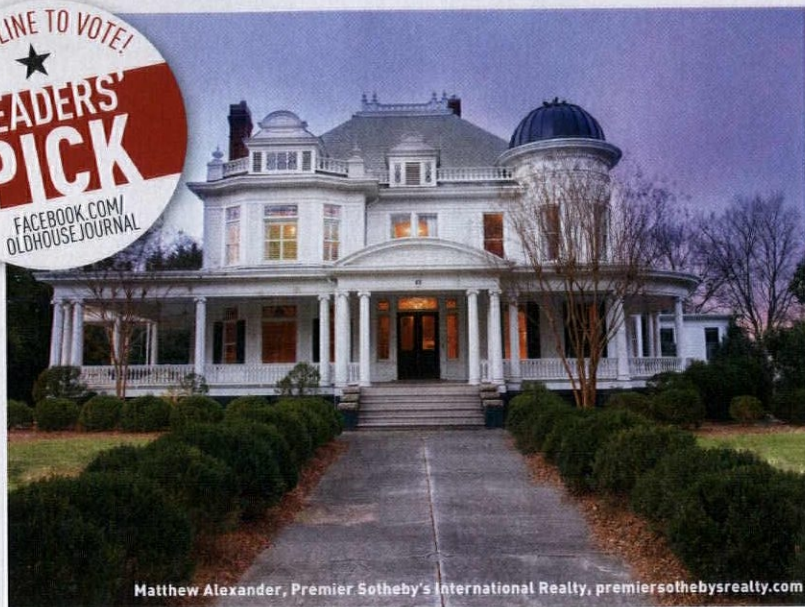

Matthew Alexander, Premier Sotheby's International Realty, [premiersothebysrealty.com](http://premiersothebysrealty.com)

### CONCORD, NC / \$899,000

The neoclassical J.W. Cannon mansion offers 9,950 square feet of living space, not including the wrap-around porches with fluted Ionic columns. Inside the ca. 1900 dwelling: original paneling and trim, 10 fireplaces, parquet floors, enriched ceilings, stained-glass windows, and a stained-glass skylight dome.



Joyce Perrin, Promiseland Realty, [promiselandusa.net](http://promiselandusa.net)

### UNION SPRINGS, AL / \$395,000

Built by a physician in the 1850s, this Moorish Revival home with Greek Revival features is distinguished by a rare ogee-arched spandrel. Interior details include 12' ceilings, a grand staircase, heart-pine floors, original mantels, and a half-octagon 1896 addition with a period bathroom.



Meysanya Morrison, Real Living Kee Realty, [realliving.com/kee-realty](http://realliving.com/kee-realty)

### ROMEO, MI / \$550,000

Built in the mansard-roofed Second Empire style, this 1877 brick mansion has a 24'-high pierced oak staircase, period-inspired kitchen & baths, butler's pantry, and Victorian wallpapers and carpeting. The screened porch overlooks a gazebo hiding a hot tub.



Ted Wight, Dielmann Sotheby's International Realty, [dielmannsothebysrealty.com](http://dielmannsothebysrealty.com)

### ST. LOUIS, MO / \$999,900

Built in 1908 by a lumber baron, this three-storey, clay tile-roofed Mediterranean Revival villa has millwork and built-ins in quarter-sawn oak, cherry, and pecan. Features include a grand foyer, Arts & Crafts tiled fireplace, kitchen with period-friendly quarter-sawn oak cabinets, and second-floor sleeping porch.

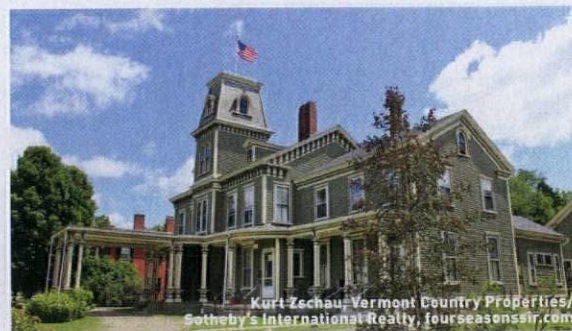

Kurt Zschau, Vermont Country Properties/ Sotheby's International Realty, [fourseasonsir.com](http://fourseasonsir.com)

### ST. JOHNSBURY, VT / \$360,000

Idlewood is an 1874 Second Empire tower house with porte cochere, roof cresting, exterior brackets and dentils, a porch with elaborate columns, and a carriage house-style, three-bay garage. Inside find marble and Queen Anne mantels and stained-glass doors with sidelights.



# WE MANUFACTURE AND SELL HANDMADE ARCHITECTURAL PRODUCTS

## ProWoodMarket

1-800-915-5110

[www.ProWoodMarket.com](http://www.ProWoodMarket.com)



- We Do Custom Work
- Over 300 Architectural Products
- Made of Western Red Cedar



Brackets

Corbels



Timber Brackets

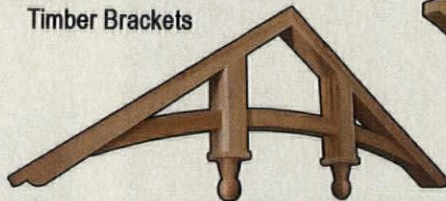

Braces



Gable Brackets



Rafter Tails



### TRUSTWORTH STUDIOS WALLPAPER



FALCON AND LILY  
CFA VOYSEY

WIDTH 21 INCHES • 7' DOLLARS 81 FT

[WWW.TRUSTWORTH.COM](http://WWW.TRUSTWORTH.COM)

598 746 1847

Designed by Daniel Contelmo R.A., A.J.A., Awarded "Best Architecture" 2014 Westchester Home Magazine



**Y**ou don't put just any shutters on a home such as this. You choose Timberlane. While most people love their look, to you, the beauty's in the details. In the clear, kiln-dried western red cedar. The mortise and tenon joinery.

The copper capping to protect joints from moisture. The knowledge that their beauty will endure. And, that they are custom made to match the most exacting of standards and the most discriminating of tastes.



Available in Maintenance-Free Endurian™ and Premium Wood

[WWW.FINESHUTTERS.COM/OHJ](http://WWW.FINESHUTTERS.COM/OHJ)

Timberlane, Inc. • 150 Domorah Drive • Montgomeryville, PA 18936 • 800 250 2221

“Kazume”

Shown here in *Ebony*, from our shimmering new Japanese wallpaper collection. Hand-silkscreened.

Samples available at [www.bradbury.com](http://www.bradbury.com) or call 707.746.1900

**Bradbury & Bradbury**  
ART WALLPAPERS

For FREE information go to [www.oldhouseonline.com/lit](http://www.oldhouseonline.com/lit) ▼

Imitated, but never duplicated.

# THE ORIGINAL MILK PAINT

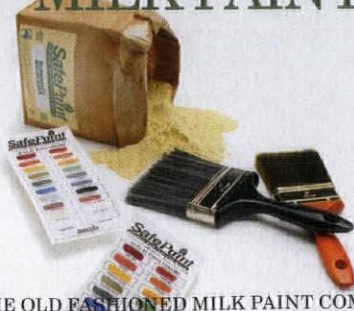

The original, all-natural paint with the soft chalky finish, and the original powdered formula, since 1974. **Just add water and paint!** Check out our Facebook page for milk paint projects and inspiration!



Naturally safe Historic Paints since 1974

THE OLD FASHIONED MILK PAINT COMPANY • toll free (866) 350-6455 • [www.milkpaint.com](http://www.milkpaint.com)

## Reasons to buy direct from DESIGNER DOORS™

### We Design-in Architectural Harmony™:

This door style carries an architectural theme that is complemented by a matching entry door and shutter. All with low maintenance and standard operational functionality.



### Your Satisfaction:

You're not the type of person to design your home from a catalog, so why accept anything less for your doors, shutters, and gates?

Speak directly to your design/sales consultant

**1-800-241-0525**

[www.DesignerDoors.com](http://www.DesignerDoors.com)



**DESIGNER DOORS™**

ARCHITECTURAL HARMONY™

a division of Cabrio Companies

## what's new... CABRIO OPENING WALL SYSTEMS



Opening walls enable noise and wind control on your patio and give you the opportunity to crack your walls open for a soft breeze.

### STACK



A sophisticated choice keeps inclement weather from ruining patio experiences.

### SLIDE



Capable of spanning long distances, sliding walls are powerful, practical, and design flexible.

### FOLD



Block wind, noise, snow, and more with an energy efficient folding wall system.

[openpatio365@cabriocompanies.com](mailto:openpatio365@cabriocompanies.com)  
[www.cabriostructures.com](http://www.cabriostructures.com)

# Restore

COUNT TO  
50 AND DUST  
OFF THE  
WORKBENCH

PAGE 42 ▶

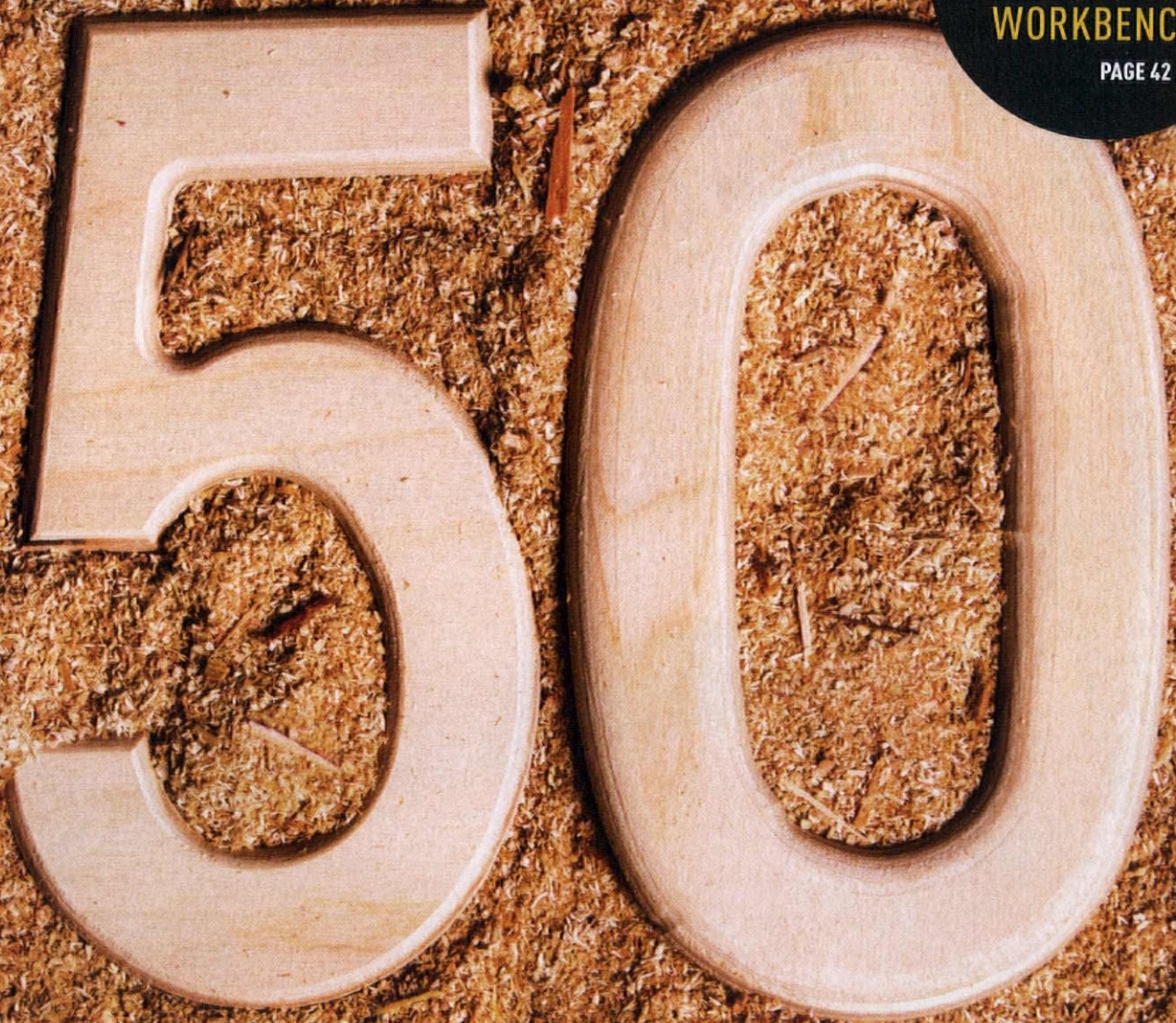

52

**LOST ARTS: CLEANING A PAINTBRUSH**  
Buy good brushes to be a better painter; then keep 'em.

+

**54 QUICK MAKEOVERS:  
LIVING ROOM TOUCHUPS**  
**56 STUFF MY HUSBAND SCREWED UP**

**58 SALVAGE IT**  
**60 DO THIS, NOT THAT**

A collection of tools including a folding ruler, a pencil, pliers, and a level on a wooden surface. The folding ruler is white with black markings and numbers, showing measurements from 150 to 199. The pencil is yellow with a red eraser and a sharpened lead tip. The pliers are dark metal with a circular hole in the handle. The level is a long, thin wooden strip with a metal bubble level in the center. The background is a dark, textured wooden surface.

# WITH HELP FROM OUR FRIENDS

Long before crowdsourcing became a buzzword, OHJ was deep in conversation with readers, contributors, and our family of experts. Here are 50 nuggets of wisdom.

COMPILED BY MARY ELLEN POLSON



OLD HOUSE JOURNAL  
BEST HOW-TO TIPS  
2015

# No. 1

Worth repeating are OHJ's founder Clem Labine's Two Golden Rules of old-house ownership:

## **NEVER DESTROY GOOD OLD WORK.**

This doesn't presuppose that all old work is good. We can fix bad original design or materials, and we can add on. We must simply exercise humility during our short tenure in a historic house.

## **TO THINE OWN STYLE BE TRUE.**

We need not create a museum, or spend inordinate amounts of money putting back what time (and misguided owners) have taken away. But, in whatever repair or addition undertaken, we must consider the period and style of the house to maintain its integrity.

—Patricia Poore, 1993



# 2

## ROLLER STRIPPER

A foam paint roller is an excellent tool for removing old wallpaper. Mix equal parts hot tap water and wallpaper-removal solution, then pour into a paint tray. Soak a clean  $\frac{3}{8}$ " or  $\frac{1}{2}$ "-nap roller with as much solution as it will hold. Start with the roller at the bottom of the wall and roll upwards. This pushes a bead of wet solution in front of the roller, ensuring even coverage. Let the mixture soak in and repeat as needed until the paper scrapes off easily. —*Diane Crudden, Providence, Rhode Island, 1994*

## No. 3 COLOR TRUISMS

Painting a room white simply because it has poor natural light will not necessarily make it bright enough for reading or other normal activities. If artificial illumination will be necessary anyway, take advantage of the ambiance with deep, rich colors and gilded accents that will glow when the lights are on. This is especially applicable to dining rooms and other spaces used predominantly in evening hours. Some Queen Anne stair halls were designed and built to be seen in subdued light, with stained-glass windows illuminating a dark and rich passageway between better-lit living areas. —*Bruce Bradbury, 1983*

No.

4

## Plaster vs. Drywall

Should you rip out less-than-perfect plaster and replace it with drywall? Not necessarily. A much better idea is to save as much sound old plaster as possible (though crumbling or buckling plaster is beyond salvaging, in many cases). Even when there are a few cracks or poor repairs, patching is cheaper than wholesale demolition and replacement with drywall. Other benefits: Real plaster walls are stronger and more soundproof than wallboard. Plaster walls also have a handmade, hard surface that contributes to the character of an old house. —*OHJ Technical Staff, 1983*

No. 5

## Prep for Wallpaper

Bear in mind the paperhanger's axiom for wall preparation: A surface should be as smooth for wallpaper as if you were going to paint it. Wallpaper doesn't conceal flaws, it amplifies them. —*Dan Cooper, 2009*

No.

6

## STRIPPING CALCIMINE PAINT

Remove layers of old calcimine or whitewash from ceilings with an application of old-fashioned wallpaper paste. Made from just wheat and water, the paste shrinks when it dries. The surface tension helps pull the old paint off. —*OHJ Technical Staff, 1983*

7

Well-selected roomsets of wallpapers richly ornament a sitting room and adjacent parlor, and lend a trompe l'oeil tray ceiling effect. Papers by Bradbury & Bradbury.



## GROUNDS

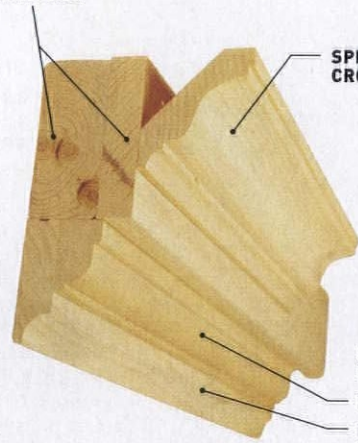

**SPRUNG MOULDING:  
CROWN MOULD**

**FLUSH  
MOULDINGS:  
BED MOULD  
PANEL MOULD**

No. **8**

## Cornice Components

An interior cornice is a molded projection that crowns architectural elements such as columns, paneling, and built-in furniture. When it caps an interior wall, it's colloquially known as crown moulding. The simplest type is flush moulding, which rests against the surfaces behind it. Another basic is sprung moulding, installed on-angle, with one edge on the wall and one edge on the ceiling. Large built-up cornices are constructed by compiling several such mouldings in a pleasing way.

—Marylee MacDonald, 1996

No. **9**

### Removing Paint from Grained Surfaces

Gently tap the paint over a paint-grained or -marbled surface with the back of a spoon. The mechanical shock separates later layers of paint from the coating of protective varnish over the original treatment.

—OHJ Technical Staff, 1983

**10**

### No Lumps

If you are using old paint for touch-up work and find that it is contaminated with dried paint or debris, try my grandmother's trick. Cut off the end of a nylon stocking and stretch it over the can. When you dip your brush, push the stocking toe down in. The paint will come through to fill your brush, but lumps won't.

—Peter Wong, Spokane, Washington, 1995

No. **11**

## WALLPAPER ON EDGE

To get a clean edge at the ceiling when wallpapering, push a thin metal ruler against the paper and butt against the ceiling for a straight line. With the ruler firm against the wall, cut the paper with a wallpaper knife. This assures an even line, and helps keep the paper from sliding or tearing if the blade is getting dull.

—Eddie Maddox, Lubbock, Texas, 1983

## TOOLS + MATERIALS

► **12** Quality paintbrushes like the Yachtsman natural bristle (\$10.99) and Shortcut (\$4.99) with flexible elastomeric handle come in sturdy paper wrappers that help the brush hold its shape after use. Wooster Brush, woosterbrush.com



► **13** Edged with a patented compression tube that holds the unit in place, these interior storms keep the cold out without blocking the beauty of original windows. About \$20 per sq. ft. Indow Windows, indowwindows.com

► **14** These compression-fit storm windows mount on the inside, sealing tightly and eliminating drafts and outside noise. About \$16 per sq. ft. Innerglass Window Systems, stormwindows.com



► **15** Soybean-based and earth-friendly, Blue Bear Paint & Urethane Stripper effectively removes multiple layers of paint, varnish, urethane, and more from almost any surface. Quart: \$21.95. Franmar Chemical, franmar.com

► **16** Cover wall cracks forever with Nu-Wal, a two-part system that consists of a water-based coating and a reinforcing fiberglass mat. It's also effective for lead encapsulation. \$109.10 and up. Specification Chemicals, spec-chem.com

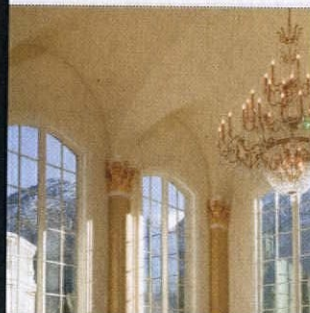

► **17** The flexible ducts of Unico's small-duct heating and cooling system can be routed through existing ceiling, floor, or wall cavities, eliminating the need for unsightly and noisy metal ductwork. System including installation, \$12,500 to \$20,000. Unico, unico.com



## 18

Flowers blooming in narrow beds spill onto a brick walkway in a side yard, softening edges and creating a vanishing point.

## No. 19

### POCKET GARDENS

Think of a small garden as an extension of the house: with a floor, walls, and a living canopy as a roof. Use walkways, planting beds, and terraces to create a circulation pattern and also to offer visual relief. Layer plantings in tiers, horizontal and vertical, which will give you a three-dimensional effect of texture and color that evolves throughout the year. —Nina Koziol, 2002

## No. 21

### Priming Porch Parts

Trim pieces are best cut to size, then primed and given a top coat of paint prior to assembly. Once in place, fill all the joints, sand, and apply the final coat of paint. —Larry Jones, 1983

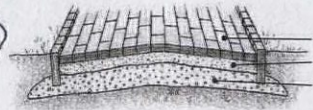
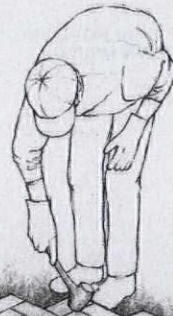

BRICK  
SAND  
GRAVEL

Bedding materials for a brick path include sand and gravel, sand over a clay base, or stone dust. Lay the pattern so that full courses of bricks are exposed. To ensure proper drainage, the path should "crown" at the center.

## 20

### Laying A Brick Walk

Setting a durable walkway is simple if you use the right materials and follow some basic steps. Begin by planning your design on paper. Use either new or salvaged hard-fired paving brick to ensure a long-lived path. To calculate the number of bricks you'll need, multiply the walk's square footage by 5 (the approximate number of bricks per square foot), allowing extra for a border and breakage.

1. Mark the walk's boundaries with stakes and a mason's line, then set the pitch. (The walk should drain at least  $\frac{1}{4}$ " per foot on either side for good drainage.)
2. Excavate the soil deep enough to accommodate a layer of bedding materials and a layer of bricks. Use either 6" of gravel topped with 1" of sand, or 4" of stone dust as a base for your bricks. Level each bed using a screed, a 2" x 6" board cut to the width of the walk. Tamp down the top layer of sand or stone dust carefully, and wet it with a fine spray of water to harden it.
3. To lay the brick, set the border first, then lay out the pavers using the pattern you drew on paper. Pack the bricks in tightly, and tap them into place with a mallet.
4. To create corners, cut good pieces off imperfect bricks using a brickset (a broad-bladed chisel). Score a line on the brick. Hold the edge of the brickset firmly on the line (bevel facing away from the part you'll use). Strike the brickset sharply with a hammer, and you should have a clean break.

Once all the bricks are in place, shovel fine sand over the entire walk, sweep it, and mist with a hose. —OHJ Technical Staff, 1998



# No. 22

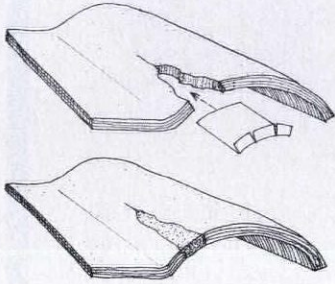

**TOP:** Use a piece of metal flashing formed to the bottom of the tile as a support for the patch. **BOTTOM:** Fill in the gap with mortar and carefully shape to the profile of the tile.

## ROOF TILE PATCH

Barrel and round clay roof tiles have great longevity—up to 300 years in some cases. Here's how to patch cracked or broken tiles, without removing them. Cut a piece of aluminum flashing and shape it to the underside contour of an undamaged tile to create a support. Wedge the aluminum in place under the damaged tile using a piece of scrap wood wrapped in thin cloth. Next, coat the broken edges with a masonry bonding agent. The glue-like product will improve adhesion between old and new materials. Mix a small batch of mortar to a workable consistency. Using a spray bottle filled with plain water, wet the area around the damage and apply the mortar, shaping it to the contour of the tile with a trowel, a wood shim, and/or your hands. Cover with a damp cloth and allow it to set up. When the repair is hard, remove the block of wood, but leave the aluminum in place for support. Sand out the new mortar's rough spots and coat it and the aluminum with patching caulk for a smooth appearance. Finally, paint it to match the rest of the roof. For clay tile, I use a red-brown sandable auto primer for a base coat, and auto touch-up paint for a topcoat. (Automotive lacquers dry hard and give a nice glazed appearance.) As an alternative, you can mix earth pigments into the mortar, but you'll need to work fast, since the mortar sets up quickly. —*Jim Petropulos, Wilmington, California, 1995*

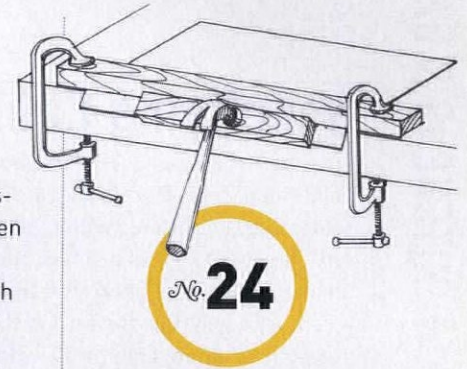

## QUICK AS A FLASHING

To replace the step flashing around my chimney, a roofer friend suggested a way to make 90-degree bends in sheet metal without buying or renting a professional metal-bending tool. I set up the metal with the bend line along the edge of my shop table, but any sturdy surface with a sharp corner will do—even a door. I held the metal fast with a piece of 2x4 lumber and two C-clamps. Then I hammered the overhanging edge down, using a 2x4 block. It produced accurate bends. —*Stacey Robinson, Fargo, North Dakota, 1994*

**ABOVE:** The edge of an old door can be used for bending flashing.

## No. 23 PATCHING A SCREEN

To patch a hole, cut a rectangle of identical screening roughly twice the size of the hole. Next, unravel three wires from the patch edge; bend ends at 90 degrees, close to the weave. Center the patch, then thread the angled wires through the screen and push them flat to secure the patch. —*Andy Olenick, 2007*

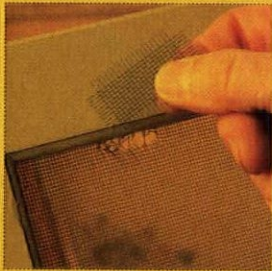

## TOOLS + MATERIALS



➤ **25** The ¾"-thick wood screen door with built-in dog door is available in many styles and woods. Even the locking lightweight flaps come in four sizes. \$155 and up. Coppawoodworking, coppawoodworking.com



➤ **26** The Breeze is a period-style door in solid wood, which converts easily to a partial screen door with a unique fold-down panel. As shown, about \$2,365. Christies Wood and Glass, entryways.com



➤ **27** Reclaimed pavers withstand centuries of traffic. They measure about 8½" x 3¾" x 3½" and weigh 9 lbs. Each brick has one smooth side from street wear. \$12 per sq. ft. plus freight. Gavin Historical Bricks, historicalbricks.com



➤ **28** The 3½" porch spindle in Western cedar is far and away the best seller from this traditional millworks house, especially in the 26" height. \$30. Western Spindle, westernspindle.com



➤ **29** Half-round copper gutters with a stylish front lip install with a unique roof-mounted hidden hanger bracket. Gutters are sold by the foot in lengths from 6' to 26'. \$6.95 and up. Classic Gutter Systems, classicgutters.com

No. **30**

## Specifying Cabinetry

For a period kitchen, cabinets should typically be a solid wood, front-frame box with raised-panel doors, preferably constructed with mortise-and-tenon joinery. The doors should be inset, and customized with an integral bead as good craftsmen would have done a century ago. While the face of the cabinet should be selected for grain, color, and lack of defects, quality should extend seamlessly to the rest of the cabinet box. A custom manufacturer will size the cabinets for the measurements of the space, allowing for irregularity in walls, with gaps between components of as little as  $\frac{1}{8}$ ". This avoids the need for "spacers" that can measure up to 3" between boxes. In both low- and high-ceilinged kitchens, the ability to specify the height of upper cabinets by the inch (instead of standard measurements like 30" or 36") means all available headroom is put to good use.

—Brian Stowell, *Crown Point Cabinetry*, 2001

**31**

An antique piece of furniture can stand in for an island or freestanding cabinet, for an unfitted look.



### TOOLS + MATERIALS

► **32** The Providence inset cabinet with a flat panel door, painted with light cream Old Fashioned Milk Paint (milkpaint.com), is the most popular choice from Crown Point Cabinetry. Full kitchens are \$30,000 and up. crown-point.com

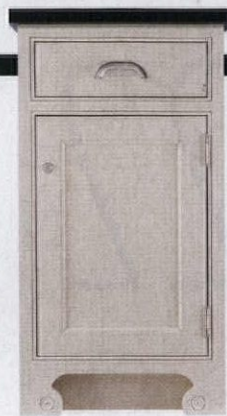

► **33** Next Generation Ultimate Double Hung windows have a timeless look, but feature such innovative elements as a keeperless hardware system, multipoint locking system, and lockable vent mode. Prices vary. Marvin, marvin.com

► **34** The Authentic Subway Tile line is offered in Avalon, an exclusive restoration-specific white glaze that was color-matched to tile in a historic home designed by Charles & Henry Greene. \$19.05 per sq. ft. and up. Heritage Tile/Subway Ceramics, heritagetile.com



► **35** Beautify old baseboard radiators with solid-cast aluminum covers that resemble architectural mouldings. Main panels, \$4.50 per inch. End caps, \$105. OverBoards, go-overboard.com



► **36** Architectural pressed-metal ceiling panels and cornices for kitchen ceilings or backsplashes are still made from original molds by this company dating to 1898. Panels (24" x 24"), \$25-\$36. Cornice (18" x 48"), \$36. W.F. Norman, (800) 641-4038, wfnorman.com



# 37

## MATCHING HISTORIC SHOWER TILE

Shower pans inevitably fail, and making repairs usually means the loss of original, often irreplaceable art tile. A skilled tile mason will save as much tile as possible, and can help you locate suitable replacements.

- Before destroying any original tile, look for replacement tile from the same or a similar manufacturer. In the 1920s and '30s, numerous companies made art tile in several genres. Hispano-Moresque was especially popular in California and the West, for instance, and tiles with iridescent glazes were popular in the East. Several companies now make reproduction tile in these styles.
- Be prepared to adapt tile even if the dimensions are wrong. Buy tiles larger than you need, then cut the new tiles down to roughly the correct dimensions. If the edges of the old tiles are shaped, contour the new ones with an alpha grinder, a tool used to polish marble.
- Before removing the original tile, photograph the entire floor and/or draw it to scale. Use these records to lay out the replacement floor.
- Once the shower pan repairs are made, lay out the new tile, following the pattern as closely as possible. Be sure to space the replacement tiles consistent with a period installation. California art tiles of the 1920s were undulating and irregular, for example, laid with grout joints of  $\frac{1}{4}$ " or more.
- Spacing modern factory-made tiles  $\frac{1}{4}$ " apart helps make the installation look old.

—Riley Doty, *Doty Tile, Artistic License, 2000*

**ABOVE:** Although the repair meant the loss of some floral wall tiles, the most visible originals remain; the tilesetter also replicated the look of the shower floor.

# 38

## cabinet door framing

The most popular cabinet door design in old houses of all ages is the wood-framed panel door, composed of two vertical stiles and two horizontal rails with a flat or raised panel in the center. Joinery types vary, depending on the era. In colonial and Victorian period cabinet doors, the lower rail is about  $\frac{1}{2}$ " wider than the rest of the frame components.

**COLONIAL TO 1850** Stiles and rails are usually about 3" wide including the moulding, which is shaped into the frame stock.

**VICTORIAN** Stiles and rails are about 2 $\frac{1}{2}$ ". Separate moulding stock was shaped, mitered, and nailed in place.

**EARLY 20TH CENTURY** Look for uniform stiles and rails (including the bottom rail) of about 2 $\frac{3}{4}$ ".

**ARTS & CRAFTS** Often a uniform frame, with stiles and rails 3 $\frac{1}{4}$ " wide.

—Dave Leonard, *The Kennebec Co., 1995*

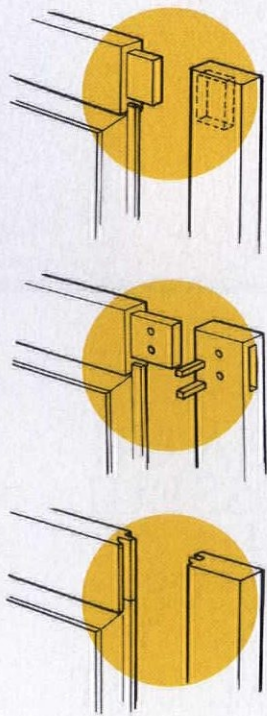

**ABOVE:** Frame joinery types include (top to bottom) blind mortise; through mortise with square pegs; and cope and stick.

# 39

## Guide to Glides

Original built-in drawers have a period look, but worn wooden runners are prone to binding. An application of wax to the runners can help; a better retrofit involves applying plastic V-channel weather stripping sold for windows and doors. Smooth down the tracks by sanding or planing, then install the channel on mating surfaces. The refurbished channel should glide easily.

—Rick Kuhlman, *Cincinnati, Ohio, 1998*



## CLEARING PIPES

An old plumber taught me how to clear a plumbing line of the last dregs of water before making repairs. To keep the water from running, poke some bread into the pipe with a pencil. The bread stops the flow long enough to solder the copper. When the water is turned on after the repair, the bread will turn to mush and run out. —W.S. McClelland, *Altoona, Florida, 1994*

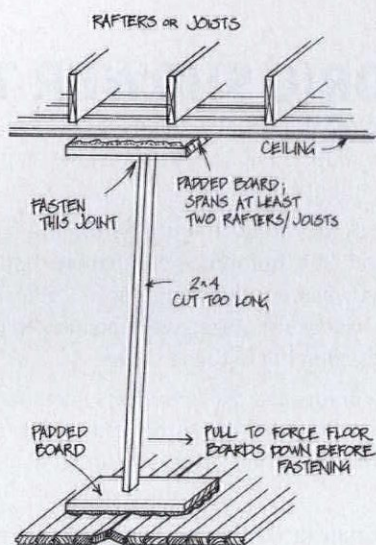

**ABOVE:** A padded T-brace uses compression to hold loose or warped floorboards in contact with the subfloor during repairs.

No. **41**

### BRACE UP

Repairs to squeaky or loose floors turn out better when the boards are pressed

firmly to the subfloor or joist before fastening. I use a T-brace made with a broad top board, a small floor wedge, and a vertical member cut so the brace is slightly longer than the ceiling height.

I jam the brace in place over the area of repair, being careful not to exert too much pressure on the ceiling. With floorboards pushed down, each nail or screw will hold the floor down tight.

For severely warped boards, I squirt construction adhesive underneath before fastening, then leave the T-brace in place until the adhesive sets. In situations where it isn't practical to take the boards up, use a large hypodermic syringe to apply wood glue through needle-sized holes. —*Anthony Novsbek, Eitzen, Minnesota, 1994*

**42**  
Sound structural underpinnings are key to making a hardware floor smooth, level, and beautiful.

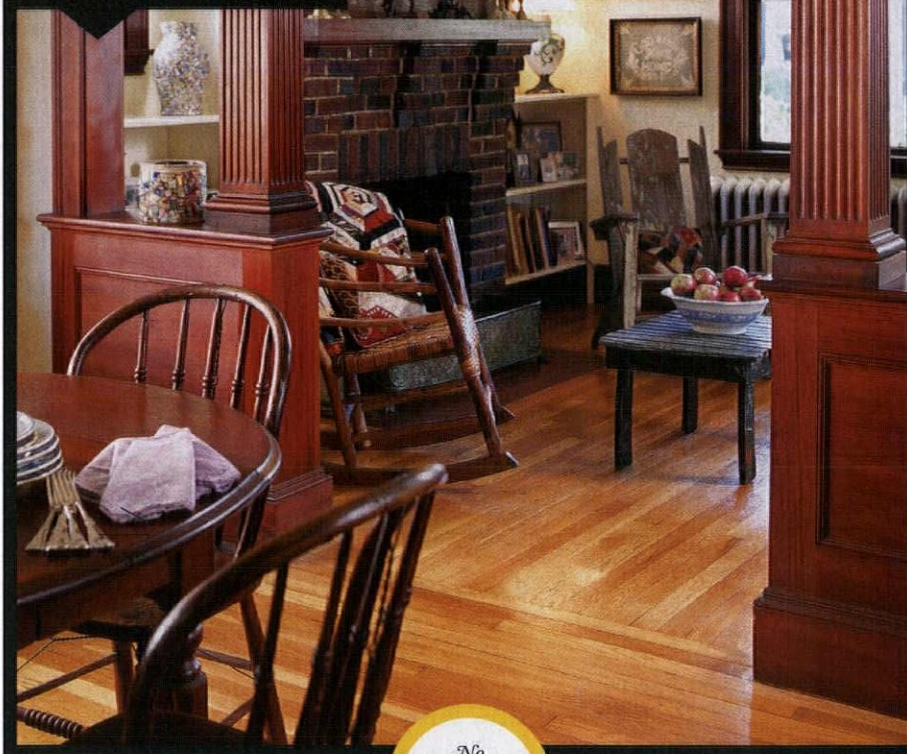

No. **44**

No. **43**  
*Cheating In*

To finesse a new piece of tongue-and-groove flooring into place, cut the bottom shoulder off the groove of the new piece. Once the patch is in place, face-nail it with a screw.

If that doesn't work, separate the tongue from the new strip using a table saw and nail it to its mate.

—*Gordon Bock, 1998*

**MY IDEA OF SUCCESSFUL STORM WINDOWS? YOU CAN'T SEE 'EM, BUT THEY'RE THERE.**

—*Hap Shepherd, Maurer & Shepherd Joiners, 2001*

## TOOLS + MATERIALS

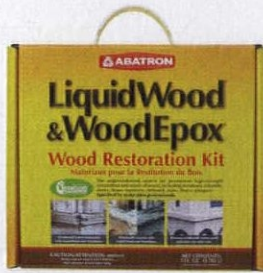

➤ **45** Restore dry-rotted or spongy wood with a 4-quart Liquid Wood & WoodEpoxy Wood Restoration Kit. The kit includes both a consolidant and a putty wood-replacement compound. \$121.95. Abatron, [abatron.com](http://abatron.com)



➤ **46** Preserve and protect weathered wood with X-180 Weathered Wood Restorer, then stain and seal it with X-100 Deck Stain and X-100 Wood Protective Coating. \$47.22–\$55.56. American Building Restoration Products, [abpr.com](http://abpr.com)



➤ **47** Rebuild wood, fiberglass, and a variety of metals with 105 epoxy resin (quart: \$35.08) mixed with specific proportions of 205 hardener (pint, 18.77). The medium bridges gaps, fills voids, and can be sanded and shaped when cured. West System, [westsystem.com](http://westsystem.com)

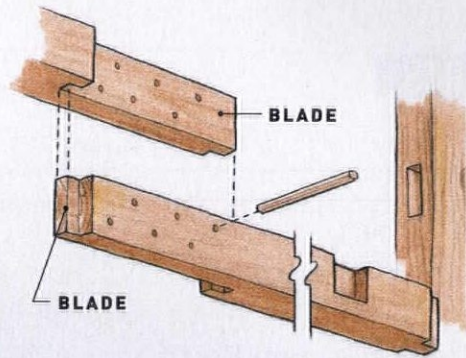

**LEFT:** In a girt repair, a replacement timber is connected with the original mortise-and-tenon joint on the post end. A traditional bladed lap joint fastens the old to the new.

# No. 48

## TIMBER FRAME REPAIR

Every framing repair is unique. For example, the solution we found for a deteriorating ceiling beam (or girt) in an 1814 timber-frame house may give you insight, but you'll need to develop a site-specific plan for your repairs with the architect, engineer, and contractor responsible for the work.

In our project, the boards encasing a girt in a side wall had begun to separate, with sawdust sifting through a  $\frac{3}{8}$ "-wide gap in the joints. The challenge was to replace the decayed wood with a new section of timber. We retained the original mortise-and-tenon joint to tie the repair to sound wood at the vertical post.

The first step was to cleanly chip away the decayed wood in the girt with a carpenter's slick (a type of long chisel) and mallet. This left a smooth face for the repair joint. To make the repair, we adapted a traditional bladed lap joint. Lap joints are usually supported by a post beneath the area of the lap. Since that wasn't possible here, we planned to support the lap by pinning it into the vertical planks below it, using the same hex-shaped oak pins that hold the lap joint together. This made it possible to slide the replacement timber into the place without damaging the plaster wall beneath it. The result is a sound repair that supports the entire framing system. —*John Leeke, 1996*



## bonded for life

Any repair made with epoxy should be considered permanent, so think twice before using epoxy on something like a historic window frame with joints that'll require disassembly. Use the epoxy only on non-jointed elements, but another repair method for jointed areas. —*Ray Tschoepe, 2008*

# No. 50

## Slippery Nails

To pull stubborn (and rusty) nails out of 100-year-old solid-oak floor planks, spray WD-40 on both ends of the nails. Let it sit for 5 to 10 minutes, and the nails will slide out with less effort. —*Dana Crocco, via Facebook, 2015*

You'll find you're a better painter when you use high-quality brushes fit for the job at hand. It's not hard to care for them and they'll last.



### SAVE IT FOR LATER

If the job is ongoing, you don't need to clean your brush every day. As long as it's not clogged with dried paint, wrap it tightly in plastic wrap or aluminum foil and store it in the refrigerator overnight; it'll be good-to-go the next day. If the weather is hot and the paint is drying quickly on the bristles—say, while you stop for lunch—put a damp cloth or paper towel around the bristles and then wrap the brush in plastic or foil until you return. Never leave a brush resting on bristles in paint for long.

## Cleaning a (Good) Paintbrush

 As with other tools, a top-quality paintbrush is a true delight, especially if you've been using inferior or throwaway brushes. You can't do a neat, efficient job without good brushes. They're expensive, however, and need some TLC. A good brush will last for years if you use it, clean it, and store it properly.

Consider whether the paint you're using is fast- or slow-setting, and be aware that the weather affects drying time. Most wall and trim paints set up slowly and thus may be cleaned from a brush at the end of the day. Primers often set up quickly and become hard to remove. Many manufacturers and painters recommend dampening the bristles before you begin work. This may help in cleaning the brush later, but be careful: you don't want to get water into the heel of the brush where it will drip and make a mess. If you dampen the bristles, best to spin or kick out excess water before you dip into paint.

Instructions here pertain to high-quality synthetic brushes and waterborne (latex) paints. **By Steve Jordan**

### NOTES ON OIL PAINT

Most DIY painters and even professionals today are using latex paints, given their improved performance under regulations limiting VOCs. When a job calls for an oil-based or alkyd paint or varnish, be sure to use a natural-bristle or nylon brush (not polyester). The cleaning solvent will be paint thinner; follow good practice for ventilation and to avoid fire.

## THE PRO TIP

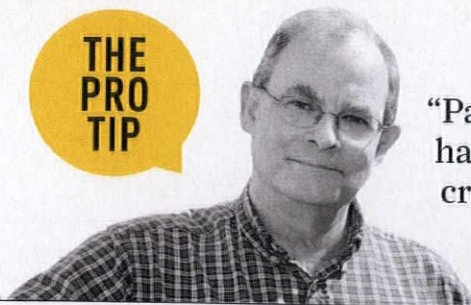

“Paintbrushes are not all-purpose; choose one for the task at hand. A brush with a lot of bristle flex holds a lot of paint and creates a smooth finish, but will get floppy with extended use. Brushes with firm or extra-firm bristle flex hold less paint, but are good for cutting straight lines.” —*Steve Jordan*

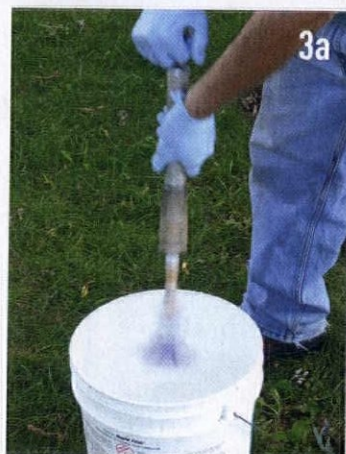
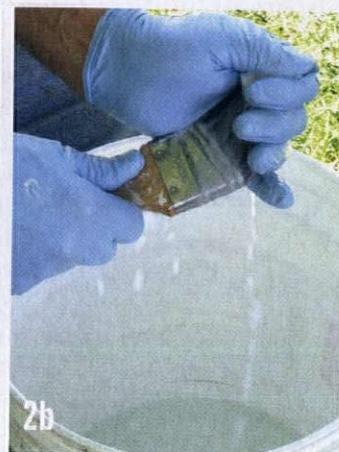

### STEP 1

When a brush has been used for several hours, the dry paint on the outside of the bristles must be brushed away. Manufacturers recommend a paintbrush comb but, after nearly fifty years of painting, I prefer a wirebrush, as do most painters. Over a bucket of water, lay the paintbrush on the rim, dip the wirebrush in the water and gently remove the dry paint by brushing from the ferrule toward the bristle ends until all the dry paint is removed.

### STEP 2

Under warm running water, hold the brush by the handle and gently bend the bristles in all directions until the paint is washed away. When the run-off looks like skim milk, add a drop of dishwashing detergent and work it into the bristles. Continue until the squeezed water looks clean enough to drink. Some latex paints contain a small amount of oil or solvent that hampers final cleaning. If the brush feels oily or sticky, rinse it in mineral spirits.

### STEP 3

Remove excess water so the brush is ready for use tomorrow. To use a brush spinner, insert the brush handle into the prongs, hold the brush inside an empty bucket, and quickly plunge the handle; one spin and it's done. The palm spin is easy if the brush has a long, slim handle, harder if the handle is fat. Place the handle between your palms over a bucket and rub hands to and fro to spin the brush. Perform the age-old toe kick by lightly tapping the ferrule of the brush on your uplifted shoe (never over a hard surface).

### STEP 4

Store the brush in its original cover to keep it like new. The bristles won't splay out and its taper will be maintained. A brown paper bag folded around the bristles makes a good substitute for the cover. Be sure to store brushes flat, or hang them through the handle hole from a wire over the workbench.



# Living Room Touchups

Here are some easy fixes and a room-changing idea that will make your historical living room look great in time for the holidays. **By Lynn Elliott**

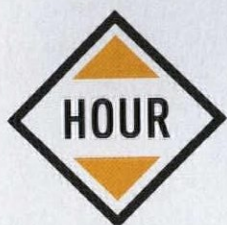

## Hide Scratches



Tackle wear-and-tear scratches, nicks, and water rings. For scratches that don't penetrate into the wood, rub a walnut or an almond into the scratch to fill it, then buff with a clean cloth. For deeper scratches, soak a black-tea bag (not green or herbal) in two or three tablespoons of water until very dark. Using a cotton swab, dab the scratch with the tea and then wipe with a clean cloth to prevent the area around the scratch from darkening. Repeat to get the desired color. For nicks or worn spots, use a wax pencil to fill in the gouge or swipe over the lighter area. Wax sticks come in many colors; you can also blend two colors in the palm of your hand. Slightly overfill the nick with the wax. Scrape off excess—a credit card works well—and rub off any wax from the surrounding area. Buff with paste wax and a clean cloth. For water rings, make a paste of baking soda just moistened with water (don't use too much!). Gently rub the affected area until the stain disappears and then buff with a clean cloth.

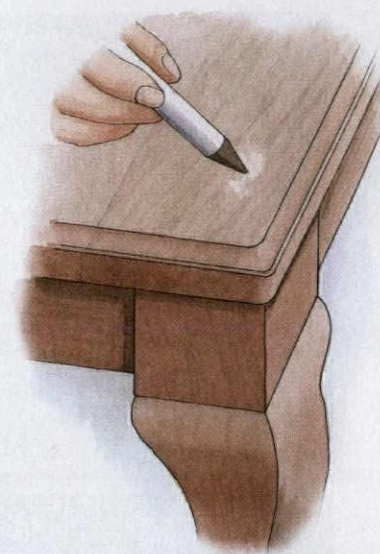

## Remove Carpet Stains

Be it a wine spill or the kids tracking in a gooey wad of gum, stains end up on the carpet or rug underfoot. To get rid of them, always blot the stain right away, working from the outside in. Then try these methods:

### PET STAINS

Remove solids with a spatula or scraper, then blot with paper towels to remove as much moisture as you can. Alternate blotting with a dishwashing-detergent solution and a white-vinegar solution (see "Food and Drink" right). Repeat until the stain is gone. Blot the area with a clean cloth dipped in warm water. Allow the carpet to air dry or use a shop vac to speed up the process.

### FOOD AND DRINK STAINS

Blot with a clean cloth, switching to a new cloth often. In a spray bottle, add a teaspoon of dishwashing detergent in a quart of warm water, spray the area, and allow to soak in for a few minutes. Blot again with a clean cloth. Next use a mixture of ¼ cup white vinegar or white wine in a quart of warm water to spray on the area. (White vinegar removes the stain and also the detergent.) Allow it to soak in and then rinse with a clean cloth dipped in warm water. Repeat until the stain has disappeared. Allow the carpet to air dry or use a shop vac to speed up the process.

### OIL AND WAX STAINS

Plug in your iron near the spot. Place a paper towel or a clean rag over the spot and iron it. The oil or wax should transfer to the towel or rag. Repeat as needed with a fresh paper towel or rag until the stain is gone.

### CHEWING GUM

Place ice cubes in a sealable plastic sandwich bag and rub until the gum hardens. Crack the hardened gum with a metal spoon and then immediately vacuum up the pieces. (You don't want them to soften again.) Blot with a clean cloth dipped in warm water.

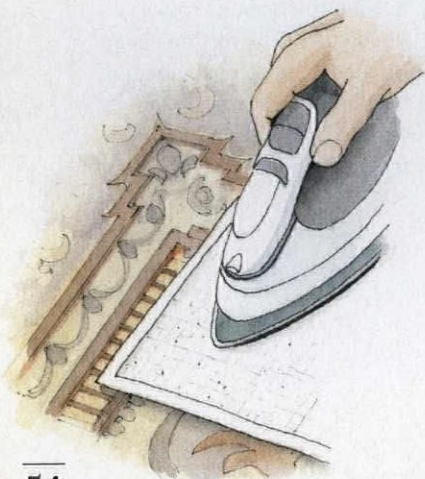



WEEKEND

## Hang a Lincrusta Frieze

Embossed Lincrusta-Walton and similar materials come in many historic patterns, including delicate swags and swirling acanthus leaves. A frieze is an economical addition; it may be finished with metallic highlights, glaze coats, or faux wood and leather effects.

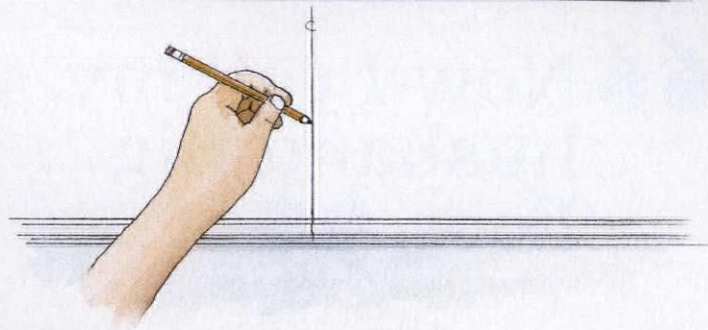

### STEP 1

Prep the walls by removing wallpaper and washing off residual glue or dirt. Fill imperfections to smooth the wall. Over plaster, hang a wallpaper liner to get the smoothest possible surface. Then apply a coat of oil-based primer and allow to dry.

### STEP 2

Measure the wall width, marking its center point with a pencil; run the mark from the wall/ceiling juncture to slightly below the frieze area so that it is visible along the bottom as the Lincrusta is being applied. It's best to work in 6' sections so the material doesn't get unwieldy. If your wall is longer than 6' feet, start from a corner and find the center point for the first section, then repeat for the next section. Start working from the least conspicuous corner of the room so that, if the pattern doesn't match up exactly at the end, it won't be as noticeable.

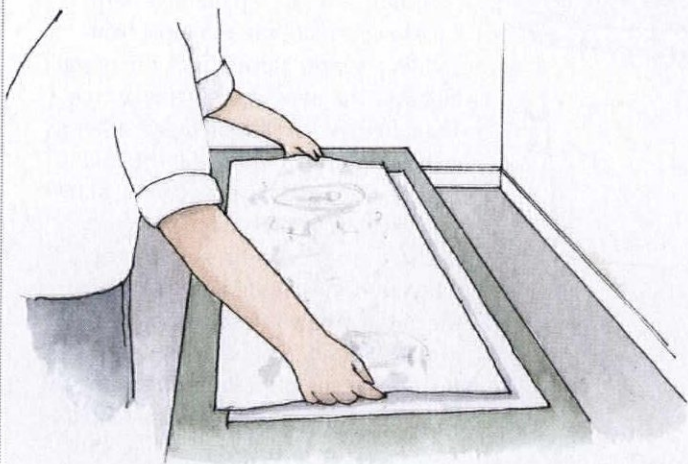

### STEP 3

Unroll the Lincrusta frieze. Take care not to bend the material too much, which can cause cracks. Measure and cut the first 6' section with a utility knife. Mark the center point with a pencil on the Lincrusta. Trim any selvage. Repeat with a second section. Turn over the Lincrusta and, using warm water, wipe the back of each piece with a sponge. Sandwich the two pieces back to back and let them soak for a half hour. Wipe off any excess water from your first piece and apply clay-based adhesive with a roller or a paintbrush. If necessary, apply some adhesive to the wall to make it tacky.

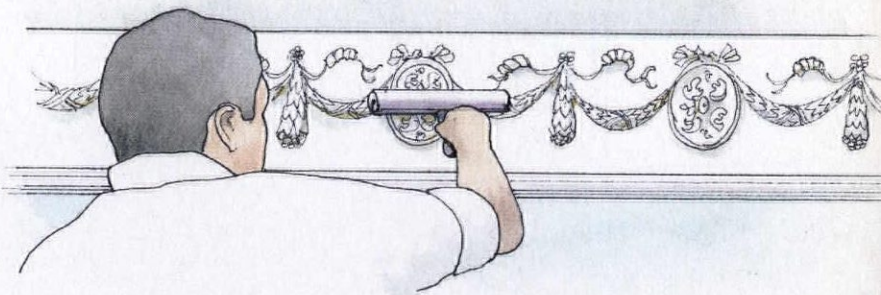

### STEP 4

Align your center mark on the wall with the one on the Lincrusta. Smooth with a clean roller, working from the middle to the edges to push out air bubbles. Wipe off excess glue with a damp sponge or rag, then wipe again with a clean sponge. Repeat the hanging process with the rest of frieze. Allow it to dry for 24 hours. Then fill in any seams with a thin bead of acrylic latex caulk and allow to dry. Wipe the entire surface with mineral spirits to remove residual glue or dirt. Use an oil-based primer and a roller with a 1/2" nap; cut-in edges with a paintbrush. Then finish the frieze in the selected decorative effect using compatible coatings.



Restore

## STUFF MY Husband SCREWED UP

# “Now I call my husband Big Foot.”



Help! My husband was rummaging around in the attic of our little 1942 Cape Cod and put his foot through the kitchen ceiling! Turns out it's plaster. The hole is a little less than one square foot in size. Gotta patch it soon, as much to save his pride as to keep squirrels from invading.— *Emmy Johnson*



### Share Your Story!

What have you, your spouse, pet, contractor, previous owner (you get the picture) screwed up? Email us at [lviator@aimmedia.com](mailto:lviator@aimmedia.com).

### THE FIX

Believe it or not, this is a classic old-house mishap. Plaster is strong and sturdy, but it isn't designed to support the weight of an adult.

Most plaster in pre-1940 houses is composed of a base of wood lath—narrow wood strips fastened to the framing inside the wall—and three different coats of plaster. The first is the scratch coat, a rough finish that works as the bridge between the wood lath and top coats. The second coat is called the brown coat, partly because of its color. The third coat is the hard, smooth putty or finish coat.

To begin the repair, remove all of the areas of damaged plaster and lath. Gently pry up pieces with gloved hands or a flat prybar. Once you've reached solid plaster, brush away all loose material, including the plaster "keys" that oozed between pieces of sound lath.

Bridge and overlap the hole with a piece of metal lath, available from building-supply stores. Tack the metal lath over the area with a screw or two. Then, holding the lath in place, use tin snips to cut the metal to fill the void exactly. Once you have a good fit, screw the new lath firmly in place.

Use the same techniques as traditional three-coat plaster to repair the patch. Apply the scratch coat rapidly, taking care to force plenty of the plaster medium through the metal lath. Score the scratch coat to help it adhere to the brown coat. While still rough, the brown coat will be smoother than the scratch coat.

Once the brown coat dries, apply the finish coat. For best results, apply thin layers of plaster multiple times, smoothing the surface and sanding after each application, until the patch is perfectly smooth and level.

Of course, you can repair a hole by cutting out a square opening, and bridging it with lath, shims, and drywall, using drywall tape and joint compound. The finish texture won't be quite the same.

ILLUSTRATION BY BRETT AFRONTI

▼ For FREE information go to [www.oldhouseonline.com/tit](http://www.oldhouseonline.com/tit)



## Sundial Wire

Cloth-Covered Wire  
Pendants

Lamp Parts  
[www.sundialwire.com](http://www.sundialwire.com)

Show off your  
windows with  
high quality  
custom

# fabricated shutters

Americana  
offers the entire  
DeVenco line of high  
quality, custom  
manufactured window  
coverings, including  
Plantation shutters,  
Colonial Wooden blinds,  
Victorian and  
Raised-Panel shutters  
and Old fashioned wood  
roll up Porch shades.



**AMERICANA**

800.269.5697

[www.shutterblinds.com](http://www.shutterblinds.com)

*to order a free brochure*

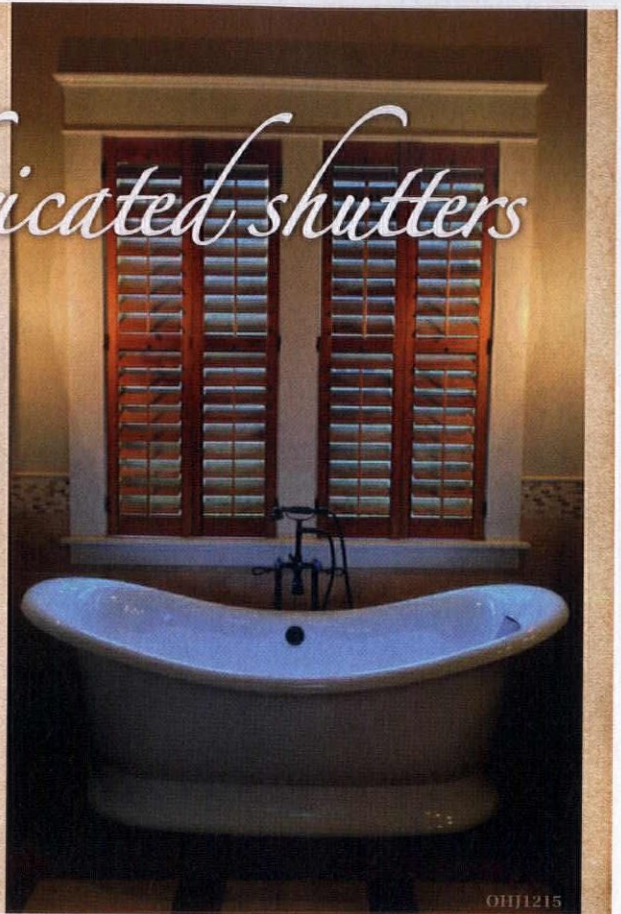

OHT1215

▼ For FREE information go to [www.oldhouseonline.com/tit](http://www.oldhouseonline.com/tit)



## Country/Farm Style Build Your Dream Table



Everything You Need  
Order Online

1.866.963.5602 [www.dininglegs.com](http://www.dininglegs.com)

▼ For FREE information go to [www.oldhouseonline.com/tit](http://www.oldhouseonline.com/tit)



The Fastest, Easiest Source,  
for the best custom porch products.



## Quality - Beauty - Durability

Cedar or Synthetic - Standard or  
Custom - Bozeman or Boston

888-459-9965

[www.westernspindle.com](http://www.westernspindle.com)





**THE COST**

vintage lino	\$50-200
steamer rental	\$25
adhesive	\$20
paper primer	\$25
brush/roller	\$45

**TOTAL \$165-315**

# A Dado from Old Linoleum

An unusually pretty bit of unused linoleum flooring found its way to a wall. **By Brian D. Coleman**

After stripping a dozen layers of paint from the mouldings of a former tenement apartment in Greenwich Village, this New York City homeowner considered installing a wainscot or dado below the chair rail. He found a dusty roll of late 19th-century linoleum (still colorful!) in a salvage shop, and saw how much it resembled Lincrusta wall covering, so often found in the entryway and halls of tenement buildings. The lino's 2' width made it the perfect size for wall panels. To prep and install the material, the owner engaged Kevin Groves, a contractor for the Lower East Side Tenement Museum and an expert on historic linoleum floors.

**LINOLEUM** is a "green" material made of natural substances that are completely biodegradable. Linseed oil is mixed with powdered wood and cork, limestone, and mineral pigments, all backed with jute. The word is derived from the Latin *lin*(um) (flax, linen) and *oleum* (oil).

Invented by English rubber manufacturer Frederic Walton in 1861, linoleum was introduced as a cheaper alternative to carpeting, tile, and hardwood floors. Flexible, water resistant, and durable, linoleum came in many patterns and colors, from imitation marble to faux oriental rugs. Linoleum remained popular for over a century; it began to be replaced with vinyl flooring in the 1960s. Note that Walton's Lincrusta was a type of linoleum made for walls.



**ABOVE:** Linoleum came in many colors and patterns; you often can find unused stock at a salvage store or specialty supplier.

## using old linoleum on walls

### 1. PREP WORK

Old lino has dried out, making it susceptible to cracking, but Kevin Groves devised a solution: He places the roll in a Sonotube—the large, round, cardboard tube used to form wet concrete for columns and posts. Choosing the right size tube, he inserts the lino inside and caps the ends with cardboard. Then, using a wallpaper steamer, he directs a gentle, steady spray of steam onto the tube for an hour or two. The slow steaming softens the hardened jute backing without damaging it or the linoleum face. This allows the material to relax and unroll without curling or cracking. Softened linoleum can be flattened further by laying it out on Masonite boards, shiny side down, and weighting it (paint cans work well).

### 2. INSTALLATION

Be careful when transporting the old linoleum after it's unrolled, as it remains fragile. Measure carefully, making sure the pattern is even and plumb within the wall area to be covered, then cut it with a sharp box cutter and trim as necessary with scissors. Prime plaster or wallboard walls first with wallpaper sizing to seal them. Be sure to use a water-soluble adhesive meant for linoleum so it won't bleed through the material; apply the adhesive to the back of the lino and hang it on the wall. Mouldings or trim pieces may be used to hold the linoleum tight and prevent edges from curling.

LEFT TO RIGHT: PHOTOS BY DAN MAYERS, LINDA SVENDSEN

▼ For FREE information go to [www.oldhouseonline.com/lit](http://www.oldhouseonline.com/lit)

# Adelphi Paper Hangings, LLC

Makers of superior grade wood block printed wallpapers and borders



Accurate reproductions from historical documents  
Custom coloring available / Full catalogue online

(518) 284-9066

[www.AdelphiPaperHangings.com](http://www.AdelphiPaperHangings.com)

▼ For FREE information go to [www.oldhouseonline.com/lit](http://www.oldhouseonline.com/lit)

## SOLID BRASS PULLEY



SRS Hardware's ball bearing pulleys are the finest available in appearance, function and durability. Featuring a carefully forged and machined one piece housing for strength and ease of installation, these pulleys will provide a lifetime of smooth and silent operation. Available in 2-1/4" and 2-1/2" sizes and five finishes.

Find these and our other restoration products at [srshardware.com](http://srshardware.com)



Why Settle?  
Your home is one-of-a-kind... your lighting should be too.

**LANTERNLAND** lighting  
[www.lanternland.com](http://www.lanternland.com) 855 454 5200 AS DISTINCTIVE AS YOUR HOME

▼ For FREE information go to [www.oldhouseonline.com/lit](http://www.oldhouseonline.com/lit)

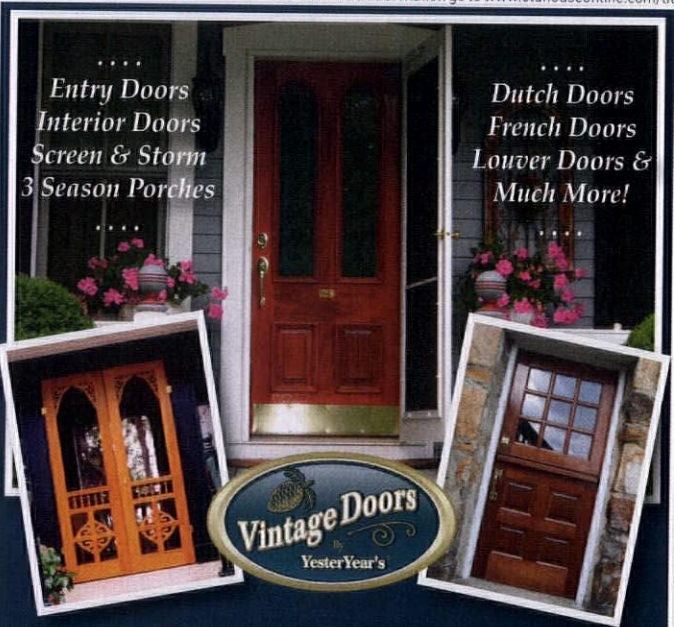

Entry Doors  
Interior Doors  
Screen & Storm  
3 Season Porches

Dutch Doors  
French Doors  
Lower Doors & Much More!

**Vintage Doors**  
YesterYear's

**HANDCRAFTED SOLID WOOD DOORS**  
Add Beauty & Value To Your Entire Home!

*"Just Like The Olden Days..."*

Shop Online | Request a Quote | Call for Catalog  
[VintageDoors.com](http://VintageDoors.com) ~ 1 (800) 787-2001



# New Mortar to Match the Original

Masonry buildings require relatively little maintenance. Besides occasional cleaning, they'll need a periodic re-establishment of the mortar joint between the individual stones or bricks; this is called pointing or repointing. Masonry walls must withstand the onslaught of wind, rain, heat, water-vapor migration, and often prolonged freezing temperatures. In a well-built wall, the brick or stone masonry units erode slowly while the mortar is the sacrificial element. When voids and crevices show up between brick or stone masonry units, it's time to consider repointing. You might do walls sequentially to spread out the cost, since deterioration may occur at a different pace. Many articles have counseled using a mortar softer than the masonry, so that the mortar rather than the brick or stone is sacrificial. Remember the aesthetics, too. Without effort applied toward tooling and color matching, repairs will be painfully obvious. **By Ray Tschoepe**

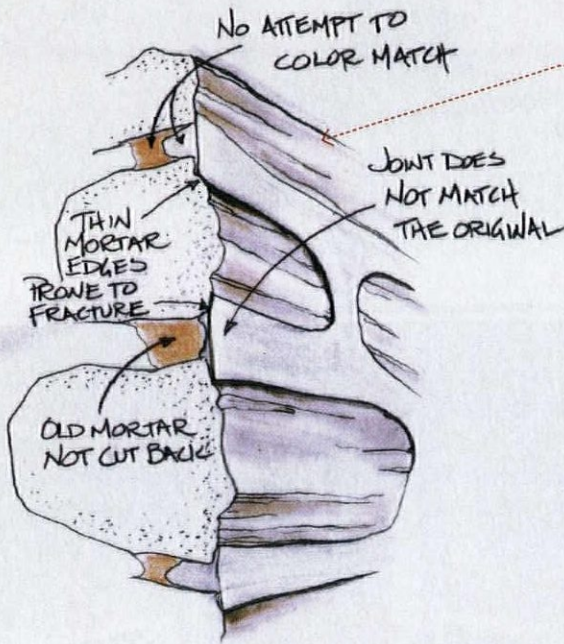

## WRONG WAY

### DON'T DO A SURFACE JOB

Effective pointing mortar should extend on average  $\frac{3}{4}$ " to 1" into the joint to provide mechanical adhesion; thus, all joints to be repointed should be raked to that depth. Some masons, however, routinely use a latex modified mortar that "sticks" to old mortar. The quick method requires only minimal joint chiseling; the goal is uniform appearance, not longevity. Modified mortar has water-vapor permeability different from that of old mortar and may contribute to masonry failure.

## RIGHT WAY

### MATCH COLOR AND TOOLING

Unless you are repointing a relatively new house, the bag off the shelf is unlikely to match. In the late 19th century, mortars were commonly colored black, brown, red, and various shades of grey and tan. Sometimes black and white particles were included. Be sure that you or your mason is familiar with the tooling of the original joints, as tooling influences the look and even the longevity of the new mortar. Tape off a 2' x 2' area to test the color match and tooling skills.

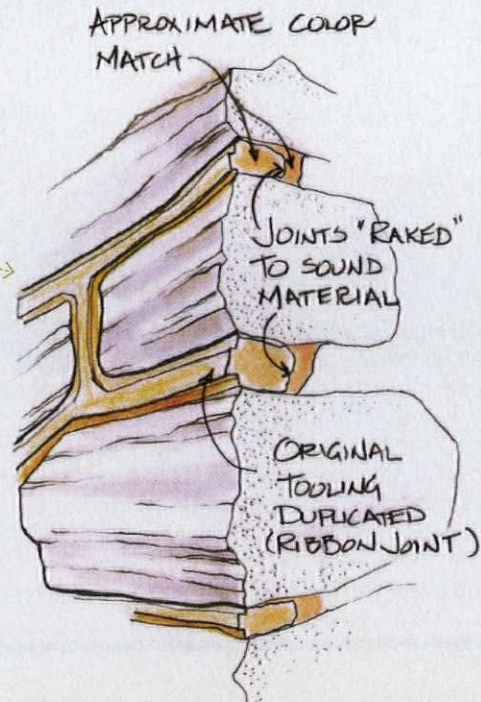

▼ For FREE information go to [www.oldhouseonline.com/lit](http://www.oldhouseonline.com/lit)

## WOOD SCREEN DOORS & STORM DOORS



Over 300 Styles  
Made in the USA  
Any Size  
Dog Doors  
Arch Tops



Wood Security Doors  
Pantry Doors  
Window Screens  
Custom Designs  
Various Woods  
Staining & Painting  
Available Direct  
Nationwide  
And Much More!

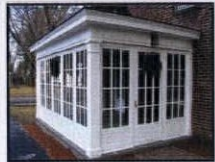

**COPPA WOODWORKING, INC.**

(310) 548-4142 [www.coppawoodworking.com](http://www.coppawoodworking.com)

▼ For FREE information go to [www.oldhouseonline.com/lit](http://www.oldhouseonline.com/lit)

## GOODTIMESTOVE.COM

Established in 1973, and in business 42 continuous years.

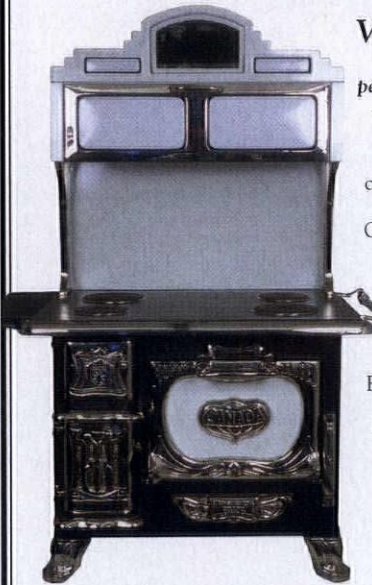

### Vintage Kitchen Stoves

Merge uncompromising performance with unique beauty!

We restore and convert antique stoves. Choose gas, electric or a combination. Every stove is customized to reflect the needs of your family and kitchen.

Our stoves satisfy the demands of the most discriminating cook.

No reproductions but original historic, American treasures adapted to meet today's modern cooking and baking conveniences.

Fully insulated for zero-clearance and vent-free installation.

If you like to cook then you will love our stoves!

Modern Conversion Available on All Models

Customized Conversion to meet the most demanding cooking needs

GoodTimeStove.com  
413-268-3677



▼ For FREE information go to [www.oldhouseonline.com/lit](http://www.oldhouseonline.com/lit)

## Helping People Build Beautiful Country Places Since 1974!

Models on Display

Models on Display

**NEW ENGLAND STYLE**  
**Country Carpenters**  
**POST & BEAM BUILDINGS**

Fine POST & BEAM Carriage Houses,  
Garden Sheds & Country Barns, Shipped Nationwide  
326 Gilead St. Hebron, CT 06248 [www.countrycarpenters.com](http://www.countrycarpenters.com) 860.228.2276

▼ For FREE information go to [www.oldhouseonline.com/lit](http://www.oldhouseonline.com/lit)

## Yesterday Meets Today At Restoration.com



**CROWN CITY HARDWARE**

Save \$5 with Promo Code OHJ1215

### The Collection



Door Hardware



Hinges



Cabinet & Furniture



Window Hardware

For FREE information go to [www.oldhouseonline.com/lit](http://www.oldhouseonline.com/lit) ▼

**W.F. Norman Corporation** *Hi Art*  
*STAMPING*  
 manufacturing hand stamped  
 tin ceilings & ornaments  
 (800)641-4038 | [info@wfnorman.com](mailto:info@wfnorman.com)

For FREE information go to [www.oldhouseonline.com/lit](http://www.oldhouseonline.com/lit) ▼

**WARD CLAPBOARD MILL**  
 Est. 1868  
 VERTICAL GRAIN QUARTER SAWN  
 Spruce Clapboards -  
 Manufacturers of historical  
 vertical grain clapboards for  
 restoration and new construction

P.O. Box 1030 Waitsfield, VT 05673 • 802-496-3581  
[www.WARDCLAPBOARD.com](http://www.WARDCLAPBOARD.com)

For FREE information go to [www.oldhouseonline.com/lit](http://www.oldhouseonline.com/lit) ▼

**HOUSE OF ANTIQUE HARDWARE**  
*Period Perfect for Your Old House*

[www.HouseofAntiqueHardware.com](http://www.HouseofAntiqueHardware.com)

For FREE information go to [www.oldhouseonline.com/lit](http://www.oldhouseonline.com/lit) ▼

**Have The Best Of Both Worlds!**

**Save Your Historic Windows with High-Tech Interior Storm Windows**

*10 Minute Install / 10 Seconds In / 10 Seconds Out*

**Innerglass®** Window Systems, LLC  
 The Compression-Fit Advantage

[stormwindows.com](http://stormwindows.com) • 800.743.6207



# Design

A KITCHEN JUST RIGHT

page 64

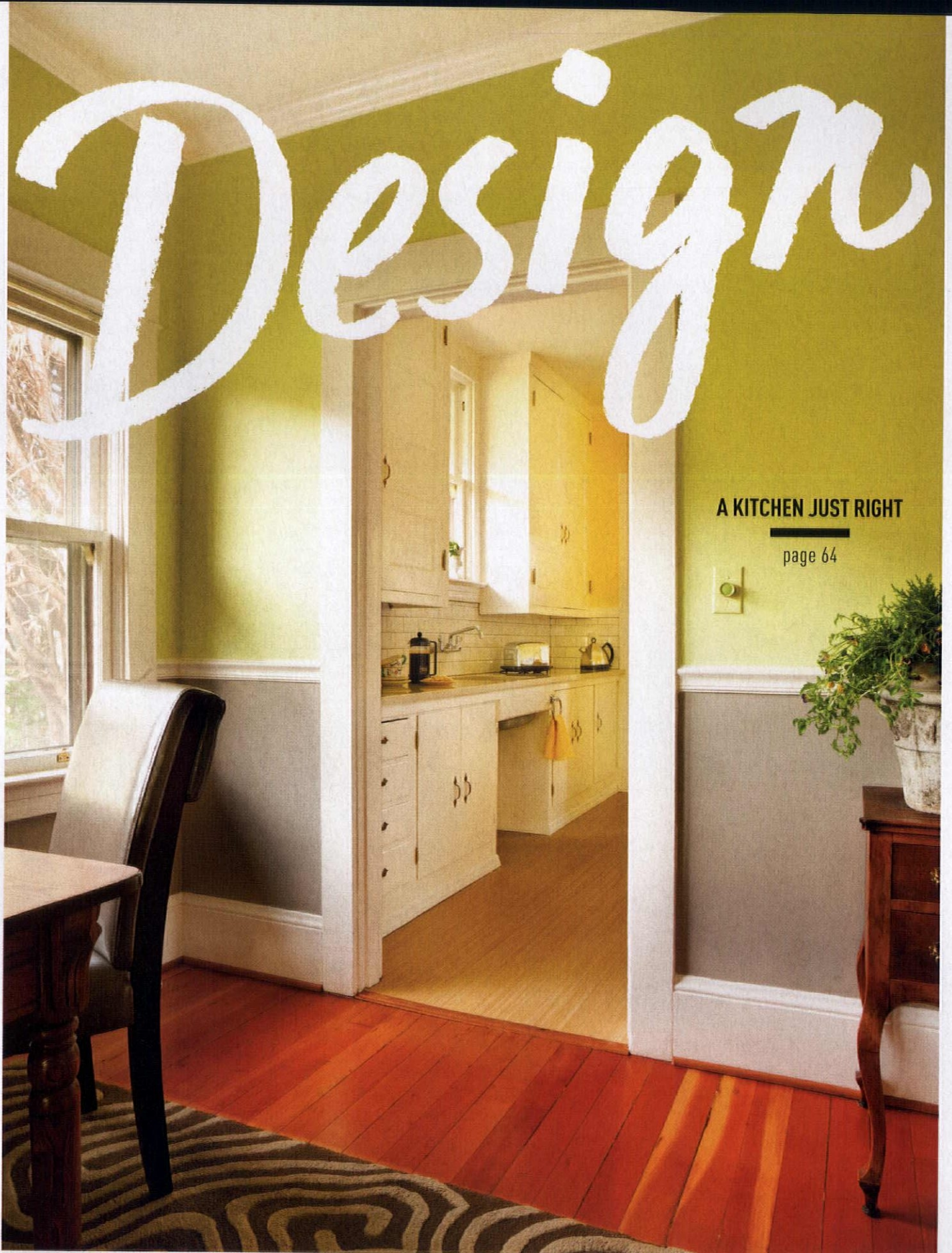

PHOTO BY BLACKSTONE EDGE STUDIOS; LETTERING BY ERIC CAPOSSOLA

72 KITCHENS + BATHS | 76 VINTAGE VISION: A & C LIVING ROOM | 78 FAVORITE THINGS: BEST SELLERS | 84 THEY STILL MAKE: *OLD HOUSE JOURNAL!*

OLD HOUSE JOURNAL  
BEST BUDGET MAKEOVER  
2015





# MAKEOVER FOR A MODEST KITCHEN

How we achieved a bungalow-era kitchen—  
on a budget, and without sacrificing  
authenticity or style.

BY DONNA PIZZI | PHOTOGRAPHS BY BLACKSTONE EDGE STUDIOS

**A**s busy owners of a boutique advertising agency called Blackstone Edge (we also team up as writer/stylist/photographer), we'd been assigned to shoot several houses in Portland, Oregon, back in 1995. The trip inspired my husband, Philip Clayton-Thompson, and me to leave Los Angeles, where we'd also worked in the film business for ten years, and head for the Pacific Northwest. Our real-estate agent showed us this 1918 Craftsman. It was love at first sight, but what clinched it was a quaint kitchen and tall cupboards that really stole my heart.

Fast-forward 20 years. The cheap vinyl flooring had chipped away at the doorways, heel dents were becoming gaping holes. The laminate countertops and backsplash had blistered, and were stained and moldy near the stainless steel sink. Appliances were dated and rundown. The stove had only three working burners. I now hated the kitchen I'd once loved.

## the work begins

While I was away at a conference last year, Philip stripped the dated wallpaper, sanded, plastered, and primed the ceiling, walls, and cupboards inside and out. (He'd done a stint plastering and painting the homes of high-profile clients in New York City.) The project languished as assignments picked up. A few months later, Philip hired an assistant painter, and together we emptied the cupboards, pulled off 20-year-old shelf lining, and washed everything down. I chose the color scheme: off-white cupboards

to match the rest of the trim in the house, and yellow walls that flowed nicely from the lime, turquoise, and grey walls in the adjoining living and dining rooms. Painting took several days.

## the floor

Removing the 1970s vinyl flooring that was littered with gashes, heel punctures, and enormous wear was physically taxing. We hired a handyman who tried several methods, but after watching a YouTube video, he and I wound up using heat lamps to soften the sheet flooring, which we could then peel away. Our pro Marmoleum floor installer, Matthew Faulkner, used a floor sander to knock down the high spots in the wood flooring before installing the 5-ply Baltic Birch 1/4" underlayment, which he then leveled with Ardex SD-F, a Portland cement-based product. In the basement, he also repaired the creaking floorboards by fastening the warped boards to the joist with large screws. We'd chosen the Marmoleum known as 'Waving Wheat', so Matthew had to lay the flooring so that its striated lines were straight going from dining room to mudroom and basement.

## countertop & backsplash

Having photographed many gorgeous kitchens in our time, we never thought we could afford beautiful countertops like the ones we had seen in other historic homes. Our client Rick Canfield, of Alpha StoneWorks, for whom we'd built a new website,

## NOTES ON INSTALLING COUNTERTOPS

Because we were keeping the original cabinets, we were bound to the shallower depth of the countertops as well as the placement of the faucet. Here are some tips on working with an installer:

- Verify that the company is accustomed to working in old houses with respect. You don't want someone who tells you to tear out the old cabinets to go standard.
- On the day the template is to be drawn, remove everything from countertops.
- Confirm that the countertop company craftspeople are able and willing to take out existing countertops and remove the sink on installation day, if necessary.
- Open a clear path from the house entry to the kitchen. Take everything out of lower cabinets because they will need a cleaning after the top is installed.
- Ask if the workers can temporarily re-install plumbing, until the backsplash is completed. Be on hand on installation day, as questions will arise.

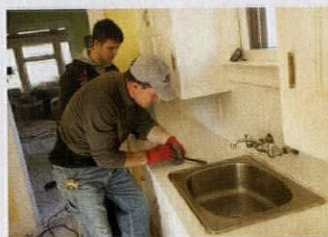

**THE SUNNY PERIOD KITCHEN FEATURES SUBWAY TILE WITH GREY GROUT AND REFINISHED CABINETS.**

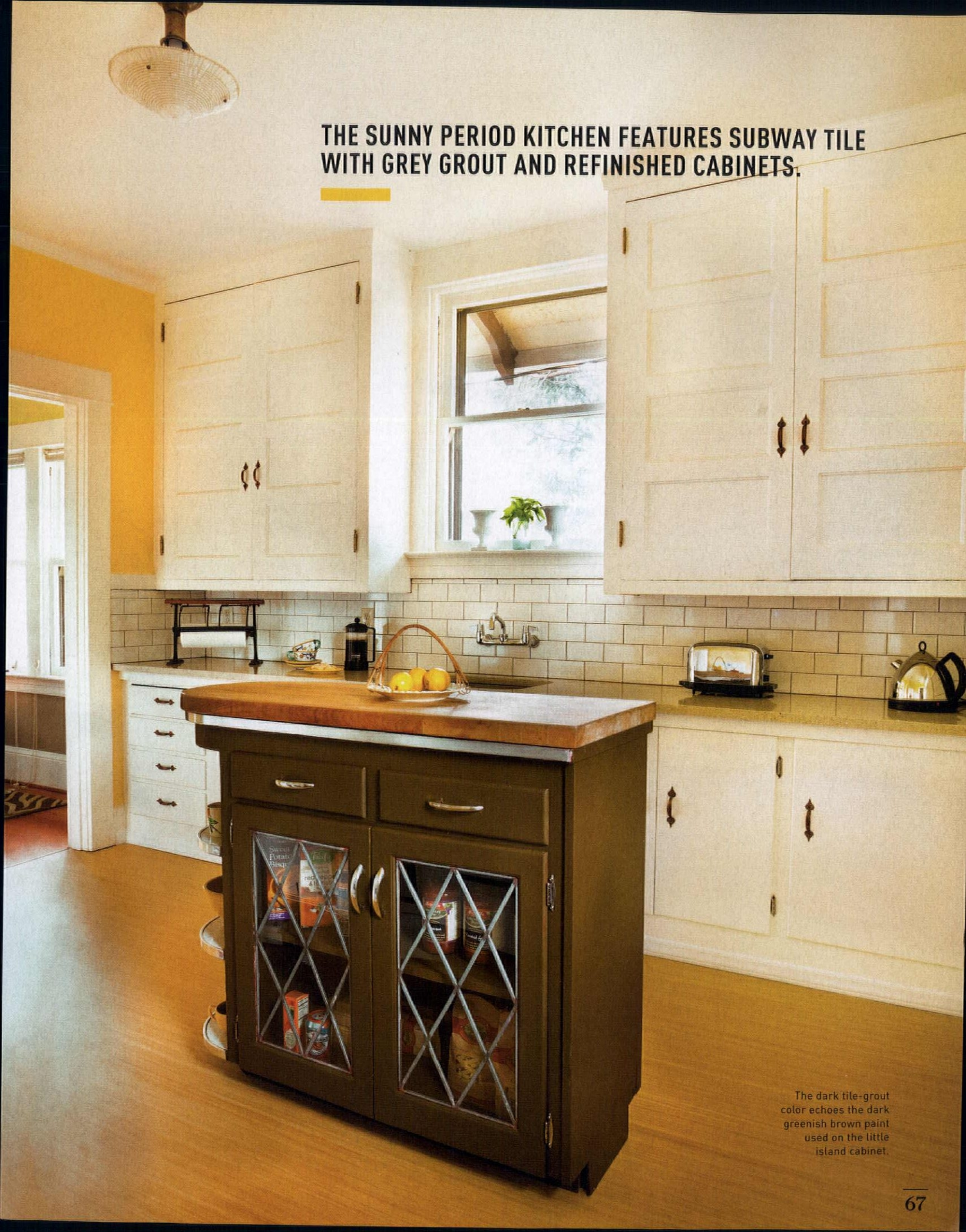

The dark tile-grout color echoes the dark greenish brown paint used on the little island cabinet.

Placed between the new kitchen sink and the gas range, a 1950s-era island with rounded shelves is convenient with its new butcherblock top.

1

3

5

2



## FIVE WAYS TO SAVE MONEY

**1. KEEP THE OLD CABINETS.** Our kitchen cabinets got a facelift, so we "paid" in labor rather than shelling out cash for new cabinetwork. When you take the doors off to sand and paint them, remember to number them! It's best if you can reuse the original hinges. Note that after you strip paint layers from the hinges, the doors close differently. You may need a carpenter to reinstall them, or at least give you some instruction.

**2. REUSE THE HARDWARE.** We kept the old hinges, dipping them in tea overnight to lend patina, and then spraying them with bronze paint, in keeping with our hammered handles. The handles were cleaned with Brasso. Keeping the old hardware means using the same holes in the wood, a great timesaver. New magnetic latches keep doors tightly closed.

**3. DON'T MOVE THE PLUMBING.** In our case, the narrow counter prohibited putting the faucet anywhere but the backsplash wall, so we weren't tempted to incur big plumbing costs by moving pipes. We found a vintage-style faucet at a restaurant supplier at a close-to-wholesale price.

**4. EMBRACE LINOLEUM.** Our Marmoleum floor is period-perfect, easy to maintain, and cheaper than tile. Ours came through a discount flooring supplier. We strongly suggest you budget for a professional installation.

**5. BUY REMNANTS.** For our countertops, we found a quartz remnant at Alpha StoneWorks, a local supplier. It was relatively inexpensive, and is scratch-resistant and easier to maintain than marble.

A 1970s remodeling left a vinyl ledge that was cut into the original window casing. Alpha StoneWorks suggested honoring the original architecture by installing the new quartz counter beneath the window.







convinced us that it was affordable. In a marked-down remnant stack, we found a speckled quartz that married well with our color scheme. Once it was installed, the countertop made the whole kitchen sparkle.

As a former New Yorker, I dreamed of replacing the ugly laminate backsplash with subway tile, as a kind of sense memory of the years I spent in Manhattan. When the laminate was removed from the backsplash, the old wood-lath and plaster wall lost patches of plaster, making it very uneven.

"That's why," Philip explains, "we hired a proficient tile person familiar with old houses, and who had some plumbing capabilities. Over a period of five days, it was necessary to undo and reconnect the plumbing several times. You don't want to be calling in a plumber for that." The subway tile is a pillow-edge version from Lowes. Stove and fridge are by Whirlpool.

## finishing touches

With new appliances in place, and our 1950s repurposed island painted a dark brownish green ('Nightfall' by Miller Paint) to pick up on the tile-grout color, the kitchen looked so period perfect, we decided to get a smaller microwave oven and relegate it to the mudroom. Only the toaster, electric teakettle, and paper-towel holder sit on the countertops. Looking back, I think we used to clutter up our old counters just to hide their condition. Now we relish the clean lines and keep it looking neat. And what a joy it is again to cook!

A new Whirlpool refrigerator tucks in nicely alongside the original built-in pantry cabinet.

## TIPS FROM THE FLOOR GUY

Matthew Faulkner installed the flooring. He's very familiar with the quirks of old houses. Here are his top tips:



**1. NO GYPSUM-BASED PRODUCTS** For underlayment leveling, "We used to use gypsum products like Fixall," Matthew says, "but we discovered the product may encourage mold and mildew in old houses, which insects use as a food source." Sometimes mold, mildew, or fungus would stain resilient flooring all the way through. Now Matthew uses Portland cement-based products, like Ardex SD-F Feather Finish.



**2. SUBFLOOR PREFERENCE** Installing Baltic Birch subflooring over building paper encapsulates previous backing and acts as a barrier.

**3. MEASURE!** The not-so-standard construction in old houses means joists may be unevenly spaced. "On this project, I measured and plotted out where each joist was; instead of the usual 16" on center we find in postwar houses, these joists were 16½' apart, then 20' apart elsewhere."

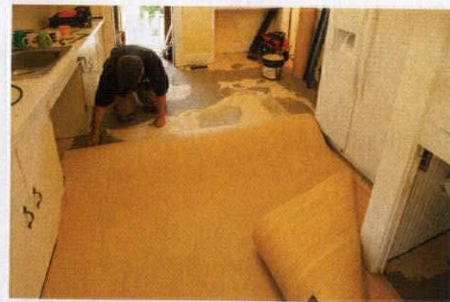

**4. PREVENTING SQUEAKS** Wooden floors do warp over time, which causes creaking when the nail into a joist slides up and down as someone walks across the floor. "Plot out joists, then secure subfloor or decking to the joists with large screws from the kitchen level," Matthew advises.



Design

KITCHENS + BATHS

# Strawberry Shortcake

A collection of red-and-white vintage kitchenware provided the inspiration for this luscious retro kitchen. **By Patricia Poore**

This imaginative kitchen is in a 1926 Colonial Revival house in Pennsylvania. The rest of the house had survived largely intact, but not so the kitchen. When the owners peeled back the 1970s version they'd inherited (think acoustical-tile ceiling, sparkly Marlite, and gold vinyl wallcovering), they discovered a 1950s remodeling underneath, featuring worn blue linoleum and white metal cabinets. Some things were original: a pantry, a 1920s wood/coal stove fitted into an alcove.

So the owners took the main room back to the era that matched their collection of kitchen furniture and housewares. It had started with a 1947 Daystrom chrome dinette set. Appliances, utensils, and decorative objects, almost all in

red or white, come mostly from the period 1945–1955. They created a reproduction kitchen complete with vented cabinet doors right out of the postwar period. (A double-drawer dishwasher hides neatly in the cabinets.) White walls are topped by a 1940s vintage 'Bantam' wallpaper border by Trimz; lower walls have white-painted beadboard. Hefty baseboards were made to match those in the rest of the house.

Vintage (unused stock) red hardware came from antiques shows and eBay. Roosters became a theme: They show up in the paper border, in drinking glasses and tea towels, in the Royal Copley figurines on round-edge display shelves—and even as a water-jet-cut motif in a few linoleum accent tiles.



## BE INSPIRED...



### SCHOOLHOUSE FAN

Similar to the 1930s Deco reproduction ceiling fan in the red kitchen is this model with a schoolhouse light, \$476. From Barn Light Electric, barnlightelectric.com



### STEPSTOOLS

They look vintage but work like new, as counter seating or a stepladder. In red or black padded vinyl, \$99.99. From Through the Country Door, countrydoor.com



### DEPRESSION PULL

This glass pull is a reproduction in colors including Depression Green. Also find a Glass Bridge Pull in Ruby, and brass 1930s pulls. Glass about \$10, metal about \$20. Crown City Hardware, store.restoration.com

### TICK TOCKS

Westclox still goes for mid-century styling. The Retro 1950 Wall Clock has a red case (\$19) and, just for fun, here's the Coffee Time 3-D Wall Clock (\$15). Online retailers or westcloxsource.com



### 1. THAT STOVE

The centerpiece of the room, it's a restored 1955 O'Keefe & Merritt 'Hi-Vue' 40" model in candy-apple red.



## 2. SHEET LINOLEUM

The flooring is real lino: Forbo's sheet Marmoleum in Blecker Street Red #3127; they offer 59 colors including brights and neutrals. The homeowners had it cut into nine-inch squares at a local water-jet cutting facility, then laid the tiles themselves.

## 3. VENTED CABINETS

The under-sink doors have metal grilles, mimicking 1940s cabinets the owner saw in old magazines. Note the "legs" with a Deco winged design (copied from a 1940s freestanding cabinet) as well as the rounded shelves popular during this period.

## 4. A WOOD VALANCE

Acting as a light baffle, the period-style topper over the windows picks up the Deco wing design. Curtains were sewn from 1940s fabric found years before at an estate sale.

## 5. COUNTERTOPS

These are WilsonArt red laminate in a reproduction "cracked ice" pattern; aluminum edging has red plastic inserts. The double-basin 1947 sink was salvaged; they paid \$25 for it years ago. Backsplash is American Olean white subway tile.



# Jewel-box Bath

Moody blue walls paired with oak wainscoting make for a Victorian room. **By Mary Ellen Polson**

The striking blue bathroom has a simple decorating scheme compared to other spaces in this Italianate row house in Brooklyn. The turn-of-the-century house was lovingly restored, and then treated to a Victorian Moorish Revival treatment that includes Turkish corners, gaslights, arabesque stenciling—and even exotic Moorish arches added between the parlors. “We were inspired by the Persian fantasy of painter Frederic Church’s house on the Hudson, Olana,” the owners explain. Not to mention that the New York couple got engaged in Pakistan.

The husband’s upstairs bathroom was, however, cued by a similar bath that appeared in the 2001 book *Bungalow Bathrooms*, by Jane Powell. The model had dark wainscoting and trim, leaded glass, a Turkish rug laid on tile, and Victorian wicker furniture. The Brooklyn homeowners fell for the moody feel that comes from pairing deep, vivid blue with dark woodwork.

The room is softly lit by daylight streaming through custom-made, stained- and leaded-glass casement windows. A reproduction high-tank toilet and an antique pedestal sink add to the sense that the bathroom has always been in the 1902 house.



## More Online

Come visit the whole house with its Moorish decorating makeover at [oldhouseonline.com/an-inspired-transformation](http://oldhouseonline.com/an-inspired-transformation).

### 1. WAINSCOTING

Oak beadboard gives a “masculine” sensibility, says the homeowner in describing the “his” bath designed for a 1902 Brooklyn limestone decorated in a Moorish Revival scheme.

### 2. LEADED GLASS

Casement windows were made for this room, lending privacy while admitting plenty of light. Shot with jewel tones from the glass, the light creates a sense of peace and serenity.

### 3. WALLCOVERING

Here, an embossed Lincrusta look-alike instantly creates a 19th-century aesthetic. The deep, vivid blue paint harmonizes with the dark oak wainscot.

### 4. A HIGH-TANK TOILET

A pull chain brings the room back to an earlier time. Moved to this room from elsewhere in the house, the wide-top pedestal sink is antique. Together, the old-fashioned fixtures suggest that this room is original.

### 5. FURNISHINGS

Minor furnishings go a long way toward a period look. The mid-19th century mirror has presence, while the Victorian craze for Eastern exotica shows up in the elephant table, Moroccan lantern, and Turkish rug.

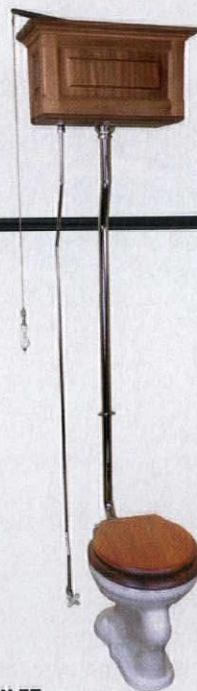

## BE INSPIRED...



### LINCRUSTA LOOK

The wallcovering is called Anaglypta Textured Vinyl, a waterproof and paintable product suitable for decorative and faux treatments. Many designs; this historical diaper pattern is #RD838, about \$25 per roll. Through [anaglyptalincrusta.com](http://anaglyptalincrusta.com)



### SPOKE HANDLES

‘Heritage’ widespread faucet set with cross handles and porcelain buttons, in satin nickel, also in polished chrome, polished brass, brass with chrome, or oiled bronze finishes. List \$349.95, through dealers. From Kingston Brass, [kingstonbrass.com](http://kingstonbrass.com)

### HIGH TANK TOILET

Reproduction toilet with wood tank and seat and a white china ‘Lydia’ bowl. Available in four wood choices and with brass or nickel, \$2,240 as shown. From Bathroom Machineries, [deabath.com](http://deabath.com)





Design

VINTAGE VISION

# from The Inviting Home / 1918

Quintessential American Arts & Crafts furniture for a living room.



A four-light chandelier with stained-glass shades adds color and sparkle to the otherwise Spartan room. Sierra Prairie Mission chandelier, \$1,056, [meyda.com](http://meyda.com)

A throwback to medieval and Tudor buildings, beamed ceilings often were found in living and dining rooms. Real or faux decorative beams re-create the look on a plain ceiling.

The even-arm settle (also called a box or crib settle) is an Arts & Crafts classic popularized by makers like Stickley and Limbert. Reissued settle, \$8,625, [stickley.com](http://stickley.com)



Another textbook A&C piece produced by big manufacturers and smaller names alike, the library table serves as the room's centerpiece and displays a few cherished objects. Prairie Mission sofa table, \$530, [barnfurnituremart.com](http://barnfurnituremart.com)

For keeping logs in place, hefty, ball-topped cast-iron andirons were particularly popular during the Arts & Crafts era. Minute-man ball andirons, \$282, [wayfair.com](http://wayfair.com)

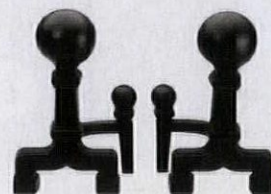

COURTESY BUILDING TECHNOLOGY HERITAGE LIBRARY/ARCHIVE.ORG

▼ For FREE information go to [www.oldhouseonline.com/lit](http://www.oldhouseonline.com/lit)



## Attractive Heating Grilles

5 Decorator Colors Guaranteed for Life



**Reggio Register Co LLC**  
Dept. D1516, 31 Jytek Road, Leominster, MA 01453  
1.800.880.3090 • [www.reggioregister.com](http://www.reggioregister.com)

▼ For FREE information go to [www.oldhouseonline.com/lit](http://www.oldhouseonline.com/lit)

Save up to **50%** or more on heating costs\*

**envi**  
wall-mounted room heater

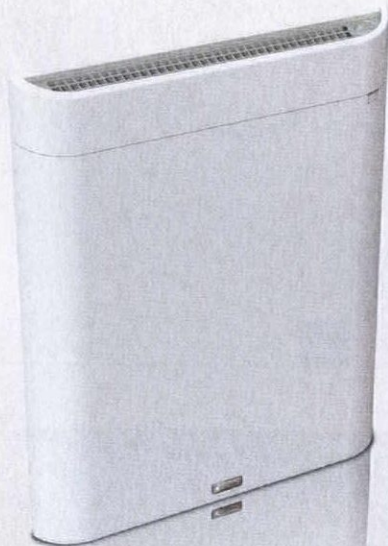

**energy saving**  
heats room for as little as 4 cents per hour\*

**ultra-safe**  
leave unattended 24/7;  
cool to the touch

**healthy**  
fanless - doesn't blow dust  
& allergens or dry the air

**effective**  
100% Pure Stack Convection;  
gentle whole room warmth!

**silent**  
fanless design, auto dimming  
power light

**easy install**  
installs in minutes, no drill;  
hardwired & plug-in models

**stylish**  
slim space saving design,  
19" wide x 2" thin!

**eheat.com 1-800-807-0107**

(\*visit our website for details) | 10% OFF Coupon: OHJ111410 | 2 or more 15% OFF Coupon: OHJ111415 | Free Shipping\*

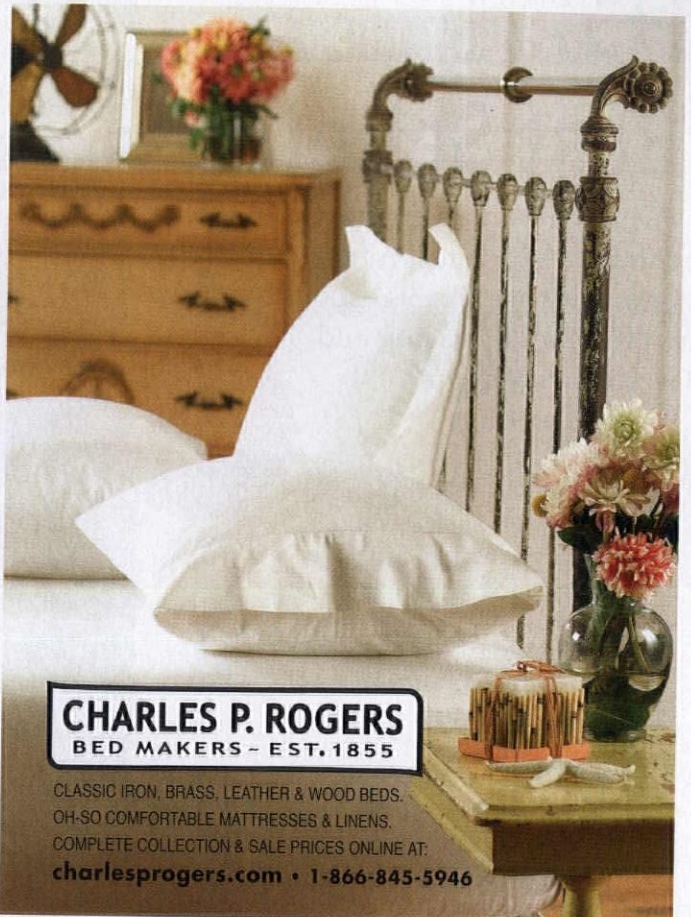

**CHARLES P. ROGERS**  
BED MAKERS - EST. 1855

CLASSIC IRON, BRASS, LEATHER & WOOD BEDS.  
OH-SO COMFORTABLE MATTRESSES & LINENS.  
COMPLETE COLLECTION & SALE PRICES ONLINE AT:  
[charlesprogers.com](http://charlesprogers.com) • 1-866-845-5946

▼ For FREE information go to [www.oldhouseonline.com/lit](http://www.oldhouseonline.com/lit)

## The WATERLESS Solution



ABR's **WATERLESS Fireplace Cleaner** is a temporary cleaning coating designed to remove dirt, soot, and contaminants, trapping them within the coating for easy collection and disposal. This removable mask requires **NO WATER** in its application or removal.

**Applies like a thick paint - Allow to dry - Peel dirt and coating off**

800-346-7532



[www.abrp.com](http://www.abrp.com)

American Building Restoration Products, Inc.

OH10713



Design

FAVORITE THINGS

# Best Sellers

We asked favorite companies about their greatest hits and hot new launches. They responded with some surprising and welcome products.

By Mary Ellen Polson

## 1. NICKEL FOR YOUR THOUGHTS

The 1865 from the Antique line includes a four-burner gas cooktop with a right-hand work surface and electric oven. Fully customizable and gleaming nickel trim is included in the price. \$6,995 and up. Elmira Stove Works, (800) 295-8498, [elmirastoveworks.com](http://elmirastoveworks.com)

## 2. SMOKY DECO

Reminiscent of Twenties jazz clubs and fancy hotel lobbies, Havana is both new and a customer favorite. The hand-printed paper comes in 30' rolls. \$70. Bradbury & Bradbury, (707) 746-1900, [bradbury.com](http://bradbury.com)

## 3. PATRIOT'S COLORS

These rabbeted and beaded raised-panel shutters are customized for a historic setting on Philadelphia's Elfreth's Alley. In Western red cedar, they are 32" x 75". About \$550 per pair. Timberlane, (800) 250-2221, [timberlane.com](http://timberlane.com)

## 4. GASLIGHT ELECTRIC

The best-selling English Victorian six-light chandelier has substantial brass castings. Trimmed with satin etched-glass shades, it measures 27" in diameter. \$2,300. House of Antique Hardware, (888) 223-2545, [houseofantiquehardware.com](http://houseofantiquehardware.com)

## 5. GATHER ROUND

Recently introduced, the tall gathering island is designed to be placed along a sofa back as an alternate seating or serving area. As shown in Mission cherry, the piece measures 90" wide x 42" tall x 25" deep. About \$2,839. Stickley, (315) 682-5500, [stickley.com](http://stickley.com)







Serial restorer **Mary Ellen Polson** is known for her discerning eye for period furnishings.

6

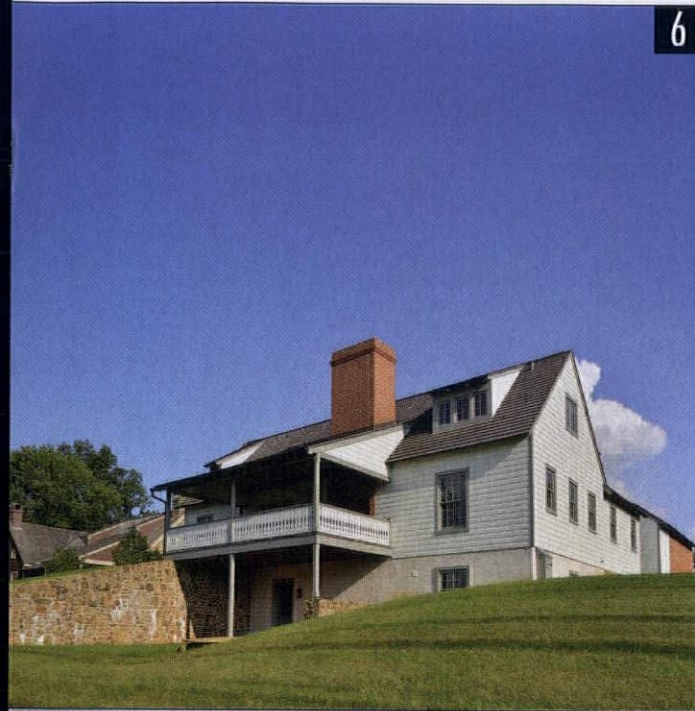

### 6. EARLY ARCHITECTURE

The Crocket House is a model home from a builder working in the early American tradition. All homes are custom designed, and can be built on your land or at Olde Bulltown Village near Philadelphia. Pricing varies. Stoltzfus Enterprises, (610) 286-5115, stoltzfus.com

### 7. TIMELESS GEOMETRY

Reproducing a French wallpaper from about 1799, the best-selling Adena was installed in the library of an Ohio house of the same name in 1808. The paper comes in 11-yard rolls. \$470. Adelphi Paper Hangings, (518) 284-9066, adelhipaperhangings.com

7



### 8. PULL ONE UP

The Cylinder pulley light is an adaptation of a turn-of-the-20th-century industrial design. Made of solid brass with cloth-covered cords and ceramic pulleys, the light has a 10" diameter shade. \$395. PW Vintage Lighting, (866) 561-3158, pwwintagelighting.com

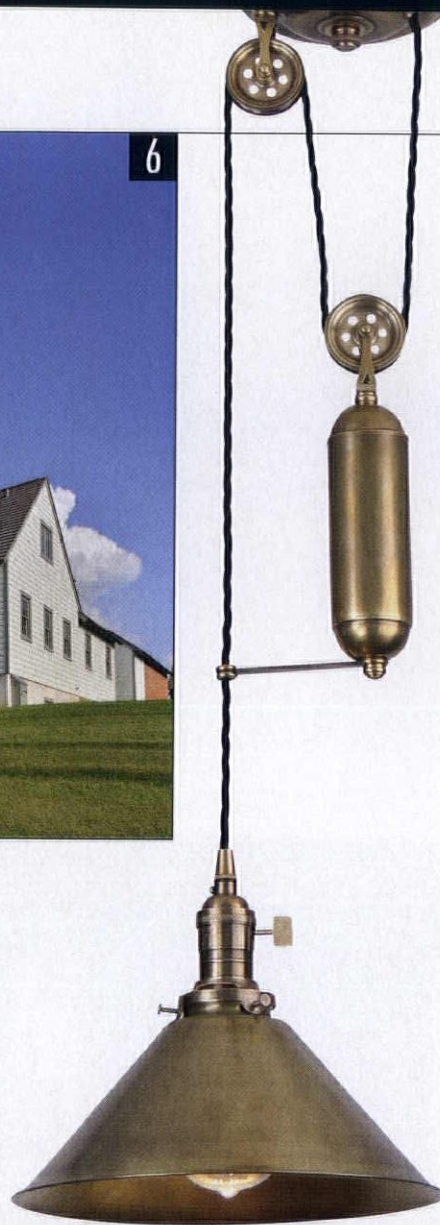

8

### 9. MORTON ROSE

Streatham Park incorporates a Donegal rose motif by Arts & Crafts carpet designer Gavin Morton and his assistant G.K. Robertson from about 1901. Woven with handspun wool, an 8' x 10' rug sells for about \$3,600. The Persian Carpet, (800) 333-1801, persiancarpet.com

9 10



### 10. THE SIGNATURE PIECE

Create the look of great age instantly with a bow-slant block sink carved from a solid block of soapstone with a Franklin edge. The rubbed lip simulates 100 years of wear. \$2,500 and up. Bucks County Soapstone, (215) 249-8181, bcsoapstone.com

### 11. UP AND DOWN

Roller shades were an inexpensive way to provide privacy and shade in early 20th-century interiors. Shown in linen with a stenciled ginkgo border, this roller shade is made to order. \$108 and up. Ann Wallace for Prairie Textiles, (213) 614-1757, [annwallace.com](http://annwallace.com)

11



### 12. GEORGIAN GRANDEUR

Raised-panel shutters were often installed from floor to ceiling in Georgian homes. These reproductions are closely patterned after 18th-century originals. They measure 36" x 72". \$805. Americana/DeVenco Products, (800) 269-5697, [shutterblinds.com](http://shutterblinds.com)

12

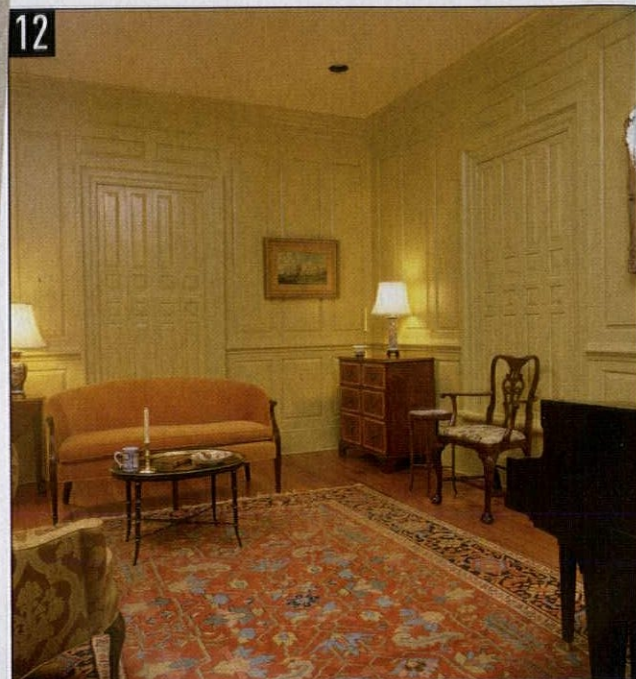

### 13. CARRIAGE TRADE

Historically inspired features and options for the carriage house-style garage door include true divided lights with insulated glass, aluminum decorative hardware based on hand-forged originals, and a choice of arched or square-top doors. \$5,200 and up. Designer Doors, (800) 241-0525, [designerdoorm.com](http://designerdoorm.com)

13



### 14. TURN THE CORNER

Square Corners is a reproduction of a common early 20th-century escutcheon and doorknob set. Shown in oil-rubbed bronze, the bit-key set measures 7 1/4" long x 2 1/2" wide. \$89.99. Crown City Hardware, (626) 794-0234, [restoration.com](http://restoration.com)

14



### 15. SLEIGH TO SLEEP

Shown in the queen size, the antique brass and iron sleigh bed in vintage white iron is one of the original designs, still popular, from this maker of classic and contemporary beds. Free delivery. \$799. Charles P. Rogers, (800) 582-6229, [charlesprogers.com](http://charlesprogers.com)

15



16

**16. COTTAGE COLORS**

Raised-panel, batten, operable- or fixed-louver, and combination shutters are available in a wide range of cottage-friendly colors, with or without cutouts, in Western red cedar. Most \$250-\$350. Shuttercraft, (203) 245-2608, shuttercraft.com

**17. FLOOR FINISHERS**

The scroll and square heat-register grilles are long-time favorites in a choice of sizes and finishes. Scroll grilles come in cast iron, brass, or aluminum; square grilles are aluminum or steel. \$28.95 and up. Reggio Register, (800) 880-3090, reggioregister.com

17

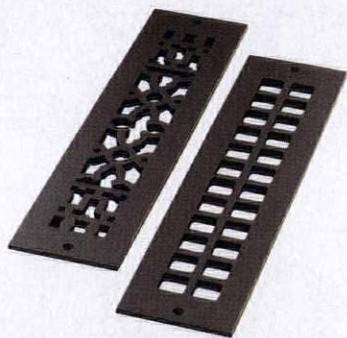

18

**18. BARN TO GO**

The one-and-a-half-storey barn kit is a perennial best seller from this maker of New England-style pre-engineered and pre-cut post and beam building kits. It measures 18' x 20'. \$18,560. Construction services available. Country Carpenters, (860) 228-2276, countrycarpenters.com

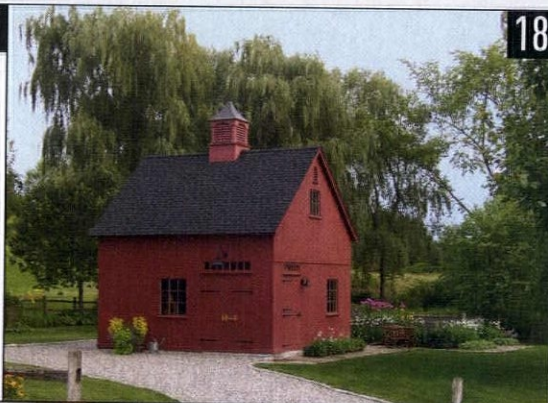

19

20

**19. STRAPPY HOOD**

The French inspired hand-crafted Montrose range hood is custom designed to fit your space. Specify it in steel or a specialty metal and a choice of custom finishes. \$4,800 and up. Raw Urth, (866) 932-7510, rawurth.com

**20. MISSION SCNCE**

With a gently sloping roof and six-sided design, the Baja Mission wall light complements a wide variety of historic house styles. It's handmade from solid copper and brass with a choice of finishes and styles of glass. \$575. Lanternland, (855) 454-5200, lanternland.com



### 21. GARDEN OF DELIGHT

Designed in 1926, Apothecary's Garden evokes the perennial childlike enthusiasm of C.F.A. Voysey's earliest work. The paper measures 21" wide. It's sold in 30 square-foot rolls. \$210. Trustworth Studios, (508) 746-1847, trustworth.com

### 22. CLEAN SCREEN

Shown in recommended African mahogany, the Old Fashion has a classic T-base shape. Options include tempered or energy-efficient glass, sidelights and transoms, and five door thicknesses. Single door, \$599 and up. Vintage Doors by Yesteryear's, (800) 787-2001, vintagedoors.com

### 23. GRAND CRYSTAL

The ever-popular Grande Victorian backplate in a vintage brass finish from the Grandeur Collection is paired with the Chambord octagonal 24-percent lead crystal knob. \$130 and up. Nostalgic Warehouse, (800) 522-7336, nostalgicwarehouse.com

### 24. RADIANT IN ZINC

The Manhattan series is based on a set of Art Deco lights from 1936. Made from zinc using lost-wax casting, the lights offer a choice of frosted or amber-tinted panels. \$295 to \$725; 46½" chandelier, \$4,750. Vintage Hardware & Lighting, (360) 379-9030, vintagehardware.com

### 25. GREEK PLAN

The Josephine Baldwin house demonstrates elements of classic Greek Revival style—yet is only 20 years old. Precisely built components for the house plan are constructed offsite, then shipped to your property for expedited construction. Prices vary. Connor Homes, (802) 382-9082, connorbuilding.com



21



23



22

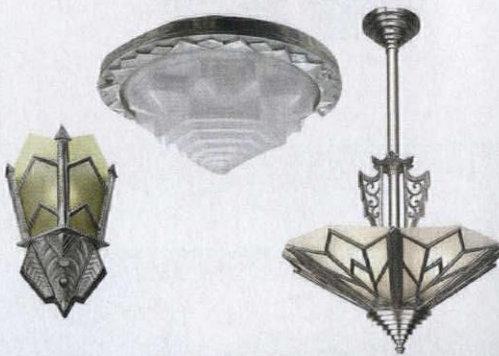

24



25

▼ For FREE information go to [www.oldhouseonline.com/lit](http://www.oldhouseonline.com/lit)

Get your paws on a  
**SHORTCUT**<sup>®</sup>  
for faster painting!



**WOOSTER**

Smooth, comfortable and precise.  
Best seller from The Wooster Brush Company.

800-392-7246 • [woosterbrush.com](http://woosterbrush.com)

▼ For FREE information go to [www.oldhouseonline.com/lit](http://www.oldhouseonline.com/lit)

[WWW.CLASSICGUTTERS.COM](http://WWW.CLASSICGUTTERS.COM)  
*Timeless quality... old world charm*



*Introducing Radius Gutter*



90" SECTIONS

HALF ROUND  
5", 6" & 8"

K-STYLE  
5", 6" & 7"



**CLASSIC**  
GUTTER SYSTEMS LLC.

*Artistry, Charm & Elegance*

COPPER, ALUMINUM & GALVALUME  
HALF ROUND GUTTERS

SHIP UP TO 26' NATIONALLY  
32 STYLES OF CAST FASCIA & DOWNSPOUT BRACKETS  
ROOF MOUNT OPTIONS AVAILABLE

PHONE: (269) 665-2700 FAX: (269) 665-1234

▼ For FREE information go to [www.oldhouseonline.com/lit](http://www.oldhouseonline.com/lit)



Your Partner in  
Kitchen Renovations



Kitchen Posts  
Corbels  
Brackets  
Cabinet Feet  
Molding  
& More

Order Online  
[www.dininglegs.com](http://www.dininglegs.com)  
1.866.963.5602

▼ For FREE information go to [www.oldhouseonline.com/lit](http://www.oldhouseonline.com/lit)



ELEGANT AFFORDABLE  
WOODEN RADIATOR CABINETS

THE PERFECT COVER-UP

For an on-site measuring appointment  
check our website under 'Sales & Events'.  
Contact us for a free brochure

[www.woodenradiatorcabinet.com](http://www.woodenradiatorcabinet.com) | 800.817.9110

▼ For FREE information go to [www.oldhouseonline.com/lit](http://www.oldhouseonline.com/lit)

**WON'T SHRINK** From Any Job



Use Durham's Rock Hard Water Putty to fill cracks and holes, rebuild missing material, and mold new objects. It permanently adheres in wood, plaster, and tile without shrinking. You can then saw, chisel, sand, polish, and color it.

The go-to solution of demanding craftsmen for more than 75 years. Available from hardware, lumber, building material, and paint dealers everywhere. [waterputty.com](http://waterputty.com)

**Donald Durham Co.**  
Box 804-HJ, Des Moines, IA 50304





Design

THEY STILL MAKE...

# OLD HOUSE JOURNAL!

➔ Begun in "brownstone Brooklyn" in 1973, its debut coinciding with that era's Back to the City movement, the early OHJ was a typewritten DIY newsletter, punched with three holes to be archived in a three-ring binder. Coverage soon expanded beyond Victorians to old houses 1690-1940 in all parts of the country. The first color cover—and paid advertising—came in 1986, sparking a "bring back the holes" wail from erstwhile subscribers. Several iterations followed, and Active Interest Media became the magazine's owner in 2007. OHJ and *Old-House Interiors* magazines merged in 2013.



More on the iPad

See more issues of OHJ throughout the years.

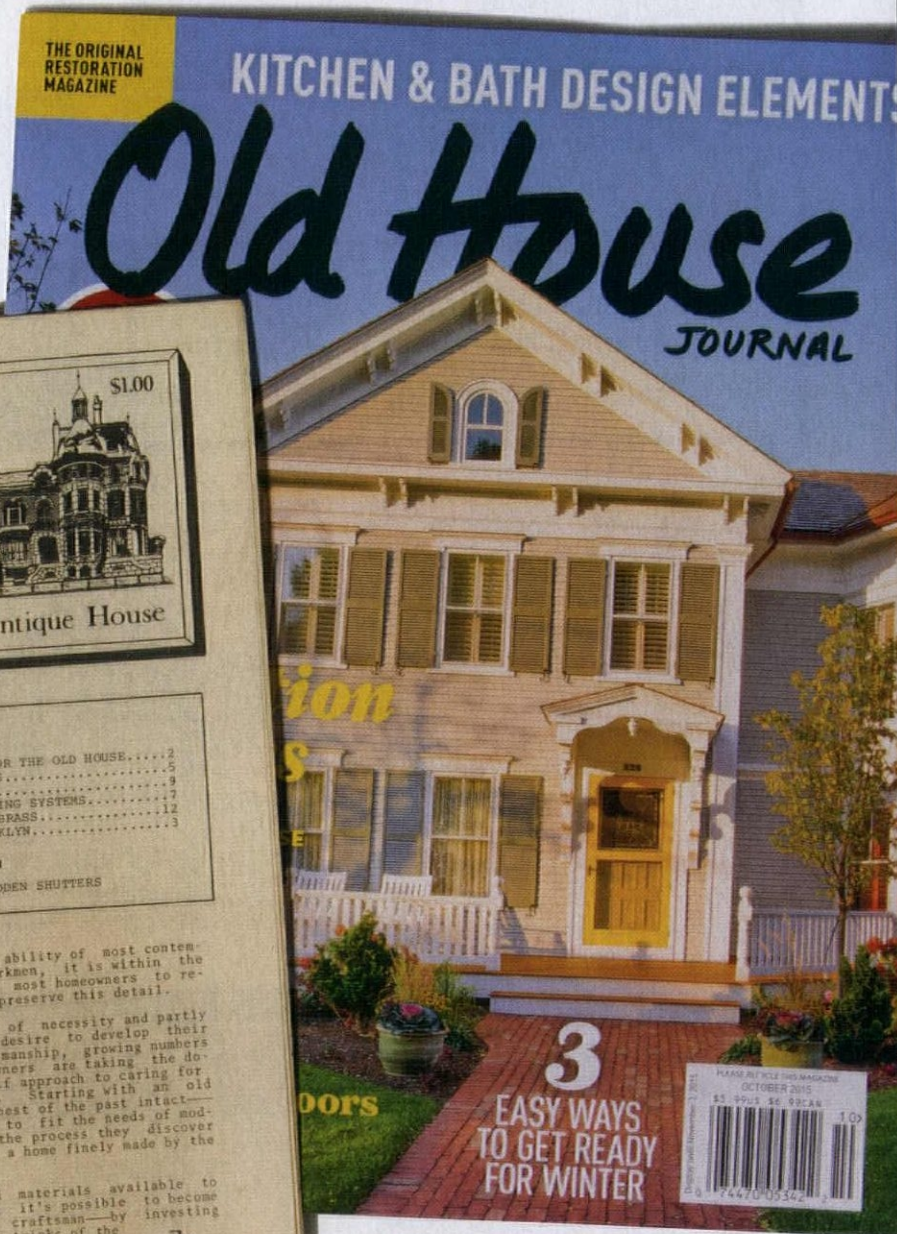

## THE OLD-HOUSE JOURNAL

Vol. 1 No. 1  
October 1973



\$1.00

Renovation And Maintenance Ideas For The Antique House

### An Old House Is A Way Of Life

OLD HOUSES aren't for everyone. Plumbing may leak; space isn't laid out efficiently; wiring isn't adequate...the list of sensible reasons why one shouldn't buy an old house goes on and on. Yet there are many who would never live anywhere else...they are truly Old House People.

WHY DO people endure the extra headaches of owning an old house—all for the privilege of living in a structure that takes on aspects of a cantankerous spouse?

FIRST, there is a romance to old houses. An old house is part of the collective memory of man; long ago joys and sadnesses linger in old halls and on dark staircases. An old house continually reminds us that people have lived before us in different times and circumstances. Through the house we share an experience in common with these other people in other times. Keeping up an old house is keeping faith with the past.

AND AN OLD HOUSE has character...in many ways resembling a living person. After being fussed with for 75 years, a house bears the imprint of its previous occupants...acquiring a personality that is unique to it.

ANOTHER CHARM of an old house is that it was unmistakably made by the hand of man. In this increasingly mass-produced world, there is something reassuring about floors that are not quite level and walls that are a little out of square.

BUT DESPITE imperfections, an old house frequently exhibits an excellence of craftsmanship and detail that cannot be duplicated today. And while the creation of such extraordinarily constructed detail is



### In This Issue

- PRE-WINTER CHECKUP FOR THE OLD HOUSE.....2
- SEALING LEAKY WINDOWS.....5
- FLAT-ROOF REPAIRS.....9
- SILENCING STEAM HEATING SYSTEMS.....17
- CLEANING UP ANTIQUE BRASS.....12
- A BROWNSTONE IN BROOKLYN.....13

### Coming Next Month

RESTORING WOODEN SHUTTERS



beyond the ability of most contemporary workmen, it is within the ability of most homeowners to restore and preserve this detail.

PARTLY out of necessity and partly out of a desire to develop their own craftsmanship, growing numbers of homeowners are taking the do-it-yourself approach to caring for their elderly homes. Starting with an old house, they keep the best of the past intact and remodel the rest to fit the needs of modern living. And in the process they discover the joy of living in a home finely made by the human hand.

WITH THE TOOLS and materials available to today's homeowner, it's possible to become one's own old-world craftsman—by investing the time to learn the tricks of the various trades. In a world that puts a premium on sheer volume of production, there's a secret satisfaction to be found in taking all of the time necessary to do a job in the very best possible way. While renovation can be a painful process, those that have gone through it successfully have found it to be one of the most creative and rewarding experiences of their lives.

TO THOSE who love old houses—and find joy in reviving them—The Old House Journal is dedicated. \*\*\*



PHOTO BY JENNY JAKUBOWSKI

## ALL OF YOUR FAVORITES



*always  
at your  
fingertips*

CHECK OUT ALL OF OUR INTERACTIVE MAGAZINES: OLD HOUSE JOURNAL, DESIGN CENTER SOURCEBOOK, ARTS & CRAFTS HOMES, NEW OLD HOUSE, CABIN LIVING, LOG HOME LIVING, AND TIMBER HOME LIVING. FIND ALL OF OUR DIGITAL EDITIONS AT [OLDHOUSEONLINE.COM/DIGITAL](http://OLDHOUSEONLINE.COM/DIGITAL)

# MON-RAY®

"Quietly Making a Difference Since 1947"

## HIGH PERFORMANCE STORM WINDOWS for Residential and Commercial Buildings

- Conserve Energy
- Retain Historical Appearance
- Reduce Maintenance
- Abate Outside Noise

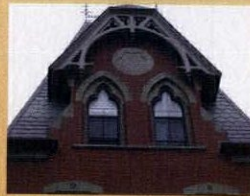
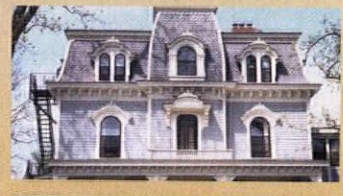

**1-800-544-3646**  
[www.monray.com](http://www.monray.com)

## NU-WAL® RESTORATION SYSTEM

MAKE WALLS & CEILINGS LOOK LIKE NEW AGAIN!

TIME TESTED  
FOR OVER  
**35 YEARS**

- LEAD ENCAPSULATION
- ONE DAY APPLICATION
- NO TRIM REMOVAL
- NO PLASTER REMOVAL

BOONE, IA  
800-247-3932

[NU-WAL.COM](http://NU-WAL.COM)  
SPECIFICATION CHEMICALS



## PRESERVATION PRODUCTS, INC.

Protecting America's heritage,  
one landmark at a time.

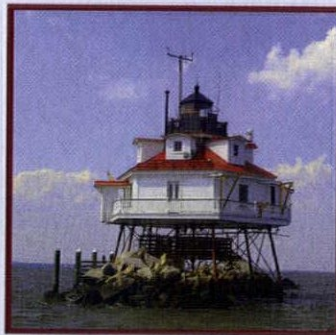

Acrymax® Coatings are dependable, durable, high performance coatings. They offer proven solutions for protecting and weatherproofing buildings of all types.

**Metal Roof Restoration**  
**Recover Low-slope Roofs**  
**Masonry Wall Coatings**  
**Protective Coatings**

1-800-553-0523  
[www.preservationproducts.com](http://www.preservationproducts.com)

## VICTORIAN LIGHTING WORKS



P.O. BOX 469  
251 S. PENNSYLVANIA AVE  
CENTRE HALL, PA 16828  
814-364-9577

[VLWORKS.COM](http://VLWORKS.COM)

For FREE information go to [www.oldhouseonline.com/lit](http://www.oldhouseonline.com/lit) ▼

# Shuttercraft, Inc.

Interior & Exterior Quality Wood Shutters  
Any type - any size - any color!



**MADE IN USA**  
Family owned  
over 25 years  
**Madison, CT**  
[shuttercraft.com](http://shuttercraft.com)  
203-245-2608



For FREE information go to [www.oldhouseonline.com/lit](http://www.oldhouseonline.com/lit) ▼

## AMERICAN RESTORATION TILE

MANUFACTURER OF CUSTOM HISTORICAL TILE

1" HEXAGON | 3/4" SQUARE  
SUBWAY TILES | BASKETWEAVE  
SPIRAL | ALL OTHER HISTORICAL SIZES

{501} 455-1000  
[WWW.RESTORATIONTILE.COM](http://WWW.RESTORATIONTILE.COM)



For FREE information go to [www.oldhouseonline.com/lit](http://www.oldhouseonline.com/lit) ▼

## Ann Wallace Prairie Textiles

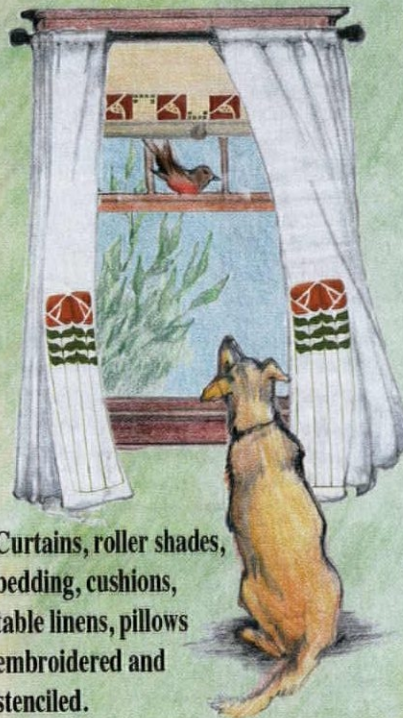

Curtains, roller shades,  
bedding, cushions,  
table linens, pillows  
embroidered and  
stenciled.

[www.annwallace.com](http://www.annwallace.com) • 213-614-1757

For FREE information go to [www.oldhouseonline.com/lit](http://www.oldhouseonline.com/lit) ▼

## ConServ EPOXY

Architectural Conservation Products  
Since 1980



[conservepoxy.com](http://conservepoxy.com)

For FREE information go to [www.oldhouseonline.com/lit](http://www.oldhouseonline.com/lit) ▼

# SHAKER

Since 1970, we have been making measured reproductions of original Shaker furniture – right here in the USA. Available as do-it-yourself kits or custom finished. Large selection of replacement Shaker chair tapes.

Call now for free catalog  
1-800-840-9121

**SHAKER WORKSHOPS**  
14 S. Pleasant St., Dept. HJ  
Ashburnham, MA 01430

[www.shakerworkshops.com/hj](http://www.shakerworkshops.com/hj)



For FREE information go to [www.oldhouseonline.com/lit](http://www.oldhouseonline.com/lit) ▼

## RADIATOR ENCLOSURES

Buy Factory Direct & Save!



Many Styles & Colors  
Baked Enamel Finish

Send \$1 for Brochure.  
Refundable with Order.

160 Airmount Road, Dept OHJ,  
Mahwah, NJ 07430 201-828-5716

**MONARCH**  
[www.monarchrad.com](http://www.monarchrad.com)



Sell your period-authentic  
products direct to our readers

## REXBILT

Sign up for a Storefront  
on REX and add your products to a  
growing selection of unique and period-  
authentic products at the best prices  
found anywhere online.

For more information, please contact:

**Robin Habberley**  
REX Sales Director  
(703) 831-6588  
[rhhabberley@rexbilt.com](mailto:rhhabberley@rexbilt.com)

**Julia Hite**  
REX Sales Executive  
(978) 729-4321  
[jhite@rexbilt.com](mailto:jhite@rexbilt.com)

**Peter H. Miller**  
VP General Manager,  
Home Group  
(202) 339-0744, Ext. 104  
[pmiller@aimmedia.com](mailto:pmiller@aimmedia.com)

[www.rexbilt.com](http://www.rexbilt.com)

## ALAMEDA SHADE SHOP

Custom-Made Window Shades

Our specialty is manufacturing authentic  
Victorian window shades with a variety  
of materials and styles.

914 Central Avenue | Alameda, CA 94501 | 877-522-0633

[www.shadeshop.com](http://www.shadeshop.com)



# Free Information Guide

**WANT FREE INFORMATION ON OLD HOUSE PRODUCTS AND SERVICES?**

Simply visit [www.oldhouseonline.com/lit](http://www.oldhouseonline.com/lit) to order your free information today!

- |   |  |  |  |
|---|--|--|--|
| <b>Acorn Mfg.</b><br>Page 92  | <b>Country Carpenters</b><br>Page 61                 | <b>Kennebec Company</b><br>Page 91               | <b>Stoltzfus Enterprizes</b><br>Page 1, 92             |
| <b>Adelphi Paper Hangings</b><br>Pages 59, 88                       | <b>Crown City Hardware</b><br>Pages 61, 89           | <b>Lanternland</b><br>Pages 59, 91               | <b>Sundial Wire</b><br>Page 57                         |
| <b>Alameda Shade Shop</b><br>Page 86                                | <b>Crown Point Cabinetry</b><br>Pages Back Cover, 89 | <b>Le Mont Hardware</b><br>Page 91               | <b>Sylvan Brandt</b><br>Page 83                        |
| <b>Allied Window, Inc.</b><br>Pages 23, 88                          | <b>Daddy Van's</b><br>Page 89                        | <b>Marvin Windows &amp; Doors</b><br>Pages 3, 92 | <b>Timberlane Inc.</b><br>Pages 39, 93                 |
| <b>Americana</b><br>Pages 57, 88                                    | <b>Designer Doors</b><br>Pages 40, 90                | <b>Mon-Ray Inc.</b><br>Pages 85, 92              | <b>Trustworth Studios</b><br>Page 39                   |
| <b>American Building Restoration Products, Inc.</b><br>Pages 77, 88 | <b>Donald Durham Company</b><br>Page 83              | <b>Monarch Radiator Covers</b><br>Page 86        | <b>Ultra Aluminum Mfg.</b><br>Pages 36-37, 93          |
| <b>American Restoration Tile</b><br>Page 86                         | <b>Dunberry Hill Design</b><br>Page 90               | <b>Nostalgic Warehouse</b><br>Page 92            | <b>Vermont Soapstone</b><br>Page 93                    |
| <b>Ann Wallace</b><br>Page 86                                       | <b>eheat.com</b><br>Pages 77, 90                     | <b>Old Fashioned Milk Paint</b><br>Page 40       | <b>Vermont Verde</b><br>Page 93                        |
| <b>Antique Drapery Rods</b><br>Page 88                              | <b>Elmira Stove Works</b><br>Pages 10, 90            | <b>Old House Guy</b><br>Page 92                  | <b>Victorian Lighting Works</b><br>Page 85             |
| <b>Architctual Accents</b><br>Page 88                               | <b>Fires of Tradition</b><br>Page 90                 | <b>Osborne Wood Products</b><br>Pages 51, 83, 92 | <b>Vintage Doors</b><br>Pages 59, 94                   |
| <b>Bradbury &amp; Bradbury Art Wallpapers</b><br>Pages 40, 88       | <b>Franmar Chemical</b><br>Pages 9, 90               | <b>The Persian Carpet</b><br>Page 2              | <b>Vintage Hardware</b><br>Pages 34, 94                |
| <b>Bucks County Soapstone</b><br>Page 88                            | <b>Garbers Crafted Lighting</b><br>Page 90           | <b>Preservation Products</b><br>Page 85          | <b>W. F. Norman Corporation</b><br>Pages 62, 94        |
| <b>Charles P. Rogers</b><br>Pages 77, 89                            | <b>Good Time Stove Copany</b><br>Pages 61, 93        | <b>ProWood Market</b><br>Pages 39, 92            | <b>Ward Clapboard Mill</b><br>Pages 62, 94             |
| <b>Christie's Wood &amp; Glass</b><br>Page 33, 89                   | <b>Harbor Freight Tools</b><br>Page 7                | <b>PW Vintage Lighting</b><br>Pages 33, 88       | <b>West System</b><br>Pages 34, 94                     |
| <b>Classic Gutter Systems</b><br>Pages 83, 89                       | <b>Heritage Tile</b><br>Pages 8, 90                  | <b>Raw Urth</b><br>Pages 23, 92                  | <b>Western Spindle</b><br>Pages 57, 94                 |
| <b>Colonial Plank Floors</b><br>Page 89                             | <b>HI-Velocity System</b><br>Pages 4, 90             | <b>Reggio Register Co.</b><br>Pages 77, 93       | <b>Wooden Radiator Cabinet Company</b><br>Pages 83, 94 |
| <b>The Color People</b><br>Page 89                                  | <b>Historic Housefitters</b><br>Page 91              | <b>Shaker Workshops</b><br>Page 86               | <b>Woolen Mill Fans</b><br>Page 94                     |
| <b>Connor Homes</b><br>Pages Inside Back Cover, 91                  | <b>Homespice Décor</b><br>Page 91                    | <b>Shuttercraft, Inc.</b><br>Page 86             | <b>Wooster Brush</b><br>Pages 83, 94                   |
| <b>Conserv Epoxy</b><br>Page 86                                     | <b>House of Antique Hardware</b><br>Pages 62, 91     | <b>Specification Chemicals</b><br>Page 85        |  |
| <b>Coppa Woodworking</b><br>Pages 61, 89                            | <b>Indow</b><br>Pages 10, 91                         | <b>SRS Hardware</b><br>Pages 59, 93              |  |
|   | <b>Innerglass Window</b><br>Pages 62, 91             | <b>Stickley</b><br>Pages Inside Front Cover, 93  |  |

ADVERTISERS IN **BLUE** OFFER FREE PRODUCT INFORMATION AT: [OLDHOUSEONLINE.COM/LIT](http://OLDHOUSEONLINE.COM/LIT)



OLD HOUSE JOURNAL  
ARTS & CRAFTS HOMES  
NEW OLD HOUSE  
EARLY HOMES  
DESIGN CENTER SOURCEBOOK  
PERIOD HOMES  
TRADITIONAL BUILDING  
**OLDHOUSEONLINE.COM**

LOG HOME LIVING  
TIMBER HOME LIVING  
CABIN LIVING  
DREAM HOME SHOWCASE  
CUSTOM WOOD HOME PLANNER  
CUSTOM WOOD HOME STYLE GUIDE  
**MYWOODHOME.COM**

## ADVERTISING INQUIRIES

**ACCOUNT EXECUTIVES**  
Becky Bernie  
(978) 879-4045  
[bbernie@aimmedia.com](mailto:bbernie@aimmedia.com)

Carol Murray  
(978) 879-4361  
[cmurray@aimmedia.com](mailto:cmurray@aimmedia.com)

**ACCOUNT EXECUTIVE, EVENTS**  
Julia Hite  
(978) 729-4321  
[jhite@aimmedia.com](mailto:jhite@aimmedia.com)

# PRODUCT SHOWCASE



## Adelphi Paper Hangings

Makers of authentic, woodblock-printed wallpapers and borders. Full line of documented patterns circa 1750-1850. 518-284-9066; [www.adelphipaperhangings.com](http://www.adelphipaperhangings.com)



## Allied Window, Inc.

The Culbertson Mansion cried out for Custom "Invisible" Storm Windows®—with bent glass for the Queen Anne turret windows. Allied Window answered the call. Interior or exterior or applications, custom colors, special shapes, and special glazing are all routine. Our abilities meet the needs of the professional in the field or the homeowner—for the conventional to the extraordinary. 800-445-5411; [www.invisiblestorms.com](http://www.invisiblestorms.com)

For FREE information go to [www.oldhouseonline.com/lit](http://www.oldhouseonline.com/lit)

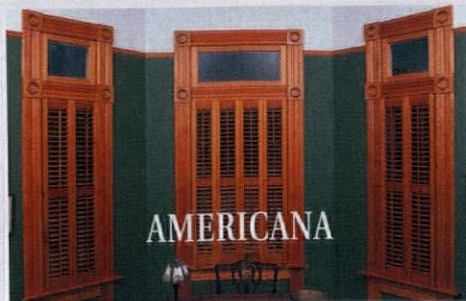

## Americana

Americana offers the entire DeVenco line of high quality, custom-manufactured window coverings, including Victorian and Plantation movable louver shutters, raised panel shutters, Colonial Wooden Blinds and old-fashioned wood roll-up Porch shades.

800-269-5697; [www.shutterblinds.com](http://www.shutterblinds.com)



## American Building Restoration Products, Inc.

ABR WATERLESS Fireplace Cleaner™ is a temporary cleaning coating designed to remove soot, dirt and grime from your fireplace. Apply, let it dry and peel the dirt away. The creamy, opaque color allows for an even and "easy to see" application. May be used on interior and exterior surfaces, and requires NO WATER in its application or removal. 800-346-7532; [www.abrp.com](http://www.abrp.com)

For FREE information go to [www.oldhouseonline.com/lit](http://www.oldhouseonline.com/lit)



## Antique Drapery Rod

Exclusive bamboo rods, 20 foot tall stalk to obtain a consistent 8 foot pole with hand selected ends. Hand tortoise shelled in a 3,000 year old style. Hand-filled hollow ends with bio based resin and cure, then hand drilled resin ends for finials, and quality inspected in our USA factory. 214-653-1733; [www.antiquedraperyrod.com](http://www.antiquedraperyrod.com)

For FREE information go to [www.oldhouseonline.com/lit](http://www.oldhouseonline.com/lit)



## Architectural Accents

30,000 sq. ft. showroom specializing in 17th, 18th and 19th century architectural antiques and reproductions. The most comprehensive selection of classic European and American design, plus experts to assist you with remodeling, restoration and installation.

404-266-8700; [www.architecturalaccents.com](http://www.architecturalaccents.com)

For FREE information go to [www.oldhouseonline.com/lit](http://www.oldhouseonline.com/lit)



## Bradbury & Bradbury Art Wallpapers

Inspired by the work of Prairie School architects Purcell & Elmslie, our newest addition to our Arts & Crafts collection captures the same soft tonal palette used in their original stenciled designs. Samples available online. 707-746-1900; [www.bradbury.com](http://www.bradbury.com)



## Brass Bracket Wall Light

This handcrafted design captures an early 20th Century industrial feel with an updated styling. Their heavy brass construction and hand rubbed finishes further contribute to the tone of that era. [www.pwvintagelighting.com](http://www.pwvintagelighting.com)

For FREE information go to [www.oldhouseonline.com/lit](http://www.oldhouseonline.com/lit)

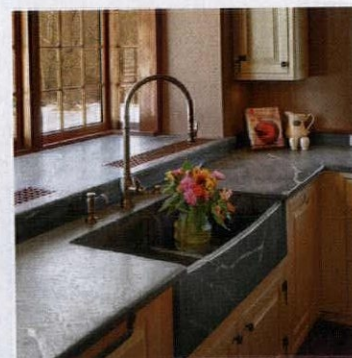

## Bucks County Soapstone

Soapstone is a simple contributor to its environment never dominating the scene. This slant front hand-built sink is accessorized with our recessed and runnels combination drainboard. 215-249-8181; [www.BCSoapstone.com](http://www.BCSoapstone.com)



### Charles P. Rogers & Co. Beds Direct

Antique brass & vintage white iron queen sleigh headboard now \$719.10, including free delivery to most addresses in continental US.

Complete collection online.

866-845-5946; [www.charlesprogers.com](http://www.charlesprogers.com)



Entry Door Mode      Transition      Screen Door Mode

### Christie's Wood and Glass

The Breeze! America's answer to the Dutch Door.

The beauty of a handcrafted entry door.

The functions of both an entry and screen door.

See the video and gallery. It's magic!

Custom Entryway builders for over 35 years.

[www.entryways.com](http://www.entryways.com)

For FREE information go to [www.oldhouseonline.com/lit](http://www.oldhouseonline.com/lit)

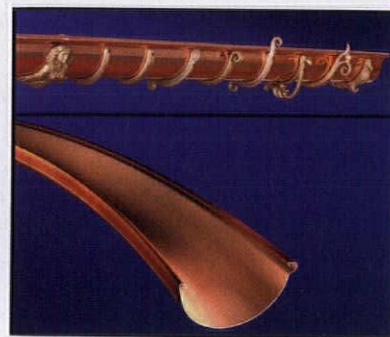

### Classic Gutter Systems, LLC

Classic Gutter Systems, LLC offers a complete half round gutter system in copper, aluminum and Galvalume including an extensive selection of cast fascia and downspout brackets and unique accessories. Ask us about our new custom radius gutter in half round and K-Style options.

269-665-2700; [www.classicgutters.com](http://www.classicgutters.com)

For FREE information go to [www.oldhouseonline.com/lit](http://www.oldhouseonline.com/lit)



### Colonialplankfloors.com

We Create Floors with Passion!

Our hand crafted plank floors are characterized by solid hardwood planks up to 13 feet long with amazing texture and beautiful hand rubbed finishes. Great choice for traditional American style.

215-997-3390; [www.colonialplankfloors.com](http://www.colonialplankfloors.com)

For FREE information go to [www.oldhouseonline.com/lit](http://www.oldhouseonline.com/lit)



### The Color People

EVERYONE DREAMS IN COLOR

For 30 years we have been making people's dreams come true all over America with our famous mail order service. We create color schemes for every style and era of buildings, residential and commercial.

303-308-0220; [www.colorpeople.com](http://www.colorpeople.com)

For FREE information go to [www.oldhouseonline.com/lit](http://www.oldhouseonline.com/lit)

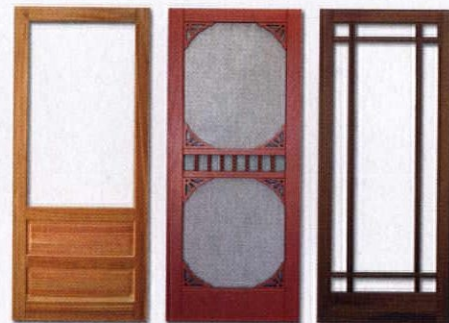

### Coppa Woodworking, Inc.

High quality, custom made wood screen and storm doors. Over 300 designs, various wood types and finishes, made to any size.

Arch tops, dog doors, security doors, window screens and storm windows are also available. Made in the USA. Available direct, nationwide.

310-548-4142; [www.coppawoodworking.com](http://www.coppawoodworking.com)

For FREE information go to [www.oldhouseonline.com/lit](http://www.oldhouseonline.com/lit)



### Crown City Hardware

We've added new traditional design knob and escutcheon sets to our collection.

Affordable, high quality sets that are a fantastic value.

[www.restoration.com](http://www.restoration.com)

For FREE information go to [www.oldhouseonline.com/lit](http://www.oldhouseonline.com/lit)



### Crown Point Cabinetry

Crown Point Cabinetry handcrafts the finest quality custom cabinetry for your entire home.

Period styles include Shaker, Arts & Crafts, Early American, Victorian, Transitional and Contemporary. Available direct nationwide.

800-999-4994; [www.crown-point.com](http://www.crown-point.com)



### Daddy Van's

Pamper your fine furniture, cabinetry, built-ins, and paneling with their all-natural, chemicalfree beeswax polish. It will leave your furniture and cabinetry nourished, healthy, and glowing.

[www.daddyvans.com](http://www.daddyvans.com)

For FREE information go to [www.oldhouseonline.com/lit](http://www.oldhouseonline.com/lit)



### Designer Doors

Designer Doors products are built by hand, each one a perfect expression of Architectural Harmony™. Unify design with matching garage doors, front entry doors, walk-through doors, shutters, and garden gates.  
800-241-0525; [www.designerdoorm.com](http://www.designerdoorm.com)

For FREE information go to [www.oldhouseonline.com/lit](http://www.oldhouseonline.com/lit)

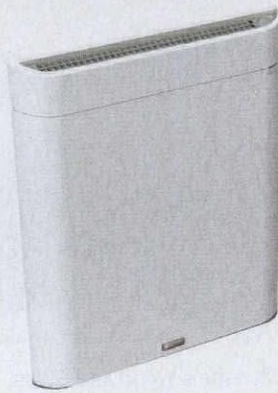

### EHeat.com

#### Envi Wall-Mounted Room Heater

Energy saving, ultra-safe, healthy, effective, silent, easy to install, stylish  
800-807-0107; [www.eheat.com](http://www.eheat.com)

For FREE information go to [www.oldhouseonline.com/lit](http://www.oldhouseonline.com/lit)



### Elmira Stove Works

Vintage-styled Northstar appliances from Elmira Stove Works are available in gas, electric or dual fuel; nine colors... ranges, fridges, microwaves, hoods, dishwashers. Also available in 1890s antique styles. As shown \$4,495 MSRP.  
800-295-8498; [www.elmirastoveworks.com](http://www.elmirastoveworks.com)

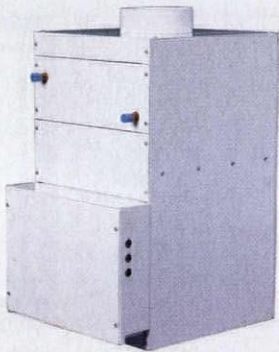

### Energy Saving Products Ltd.

The Hi-Velocity System is a Small Duct Central Heating & Air Conditioning System, suitable for historic remodels, retrofits, new construction, recreational properties, and commercial applications. Designed to fit where other systems cannot!  
[www.hi-velocity.com](http://www.hi-velocity.com)

For FREE information go to [www.oldhouseonline.com/lit](http://www.oldhouseonline.com/lit)

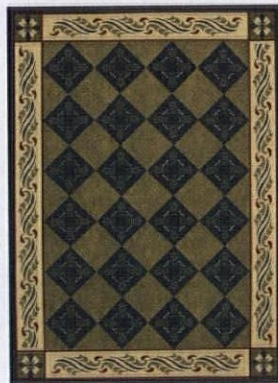

VENETIAN TILE DESIGN

### Dunberry Hill Designs

#### Traditionally Handcrafted Floorcloths

Custom made to match your decor. Visit our website to view the many quality designs in our photo galleries.  
802-874-7288; [www.dunberryhilldesigns.com](http://www.dunberryhilldesigns.com)



### Fires of Tradition

Their collection of mantels, fronts and grates will assist you with recreating or restoring a turn of the century showpiece fireplace. They offer a range of solutions for wood, gas, or an innovative and exceptionally realistic "go anywhere" electric option. Expert advice on restoring older hearths.  
(519) 770-0063; [www.firesoftradition.com](http://www.firesoftradition.com)

For FREE information go to [www.oldhouseonline.com/lit](http://www.oldhouseonline.com/lit)



### Franmar Chemical

Imagine stripping the finish off of the kitchen cupboards while the family is eating in the same room. No problem with the all-natural Soy-Gel®, the paint and urethane remover made from soybeans. No odor, environmentally safe, and can remove multiple layers with only one application.  
800-538-5069; [www.franmar.com](http://www.franmar.com)

For FREE information go to [www.oldhouseonline.com/lit](http://www.oldhouseonline.com/lit)



### Garbers Crafted Lighting

Country/Primitive Ceiling Fans  
Tinware, chandeliers, sconces, flush mounts, kitchen island, and lots more to make your country home complete. Direct from crafter.  
Dept OHJ 5/14  
866-856-2317;  
[www.garbers-craftedlighting.com](http://www.garbers-craftedlighting.com)

For FREE information go to [www.oldhouseonline.com/lit](http://www.oldhouseonline.com/lit)



### Heritage Tile

Heritage Tile is dedicated to preserving our uniquely American tile heritage with our collection of historically authentic subway tile, trim, mouldings, ceramic accessories and made-to-order mosaics.  
888-387-3280; [www.heritagetile.com](http://www.heritagetile.com)

For FREE information go to [www.oldhouseonline.com/lit](http://www.oldhouseonline.com/lit)

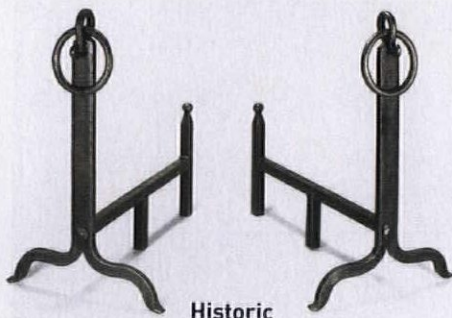

**Historic  
Housefitters Co.**

Authentic, hand-forged hardware, made in USA: iron thimbleblatches, mortise lock sets, H and HL hinges, strap hinges, hearth cooking tools, pot racks, fireplace equipment, hooks, towel bars, cabinet pulls and custom iron work.

Brass and glass door knobs and lever sets.  
800-247-4111; [www.historichousefitters.com](http://www.historichousefitters.com)



**Homespice Décor**

Inspired rugs by passionate artists. Bring traditional warmth to your home. Ideal for your living room, bedroom or outdoors, our braided rugs come in all different colors and sizes.

678-468-3022; [www.homespice.com](http://www.homespice.com)

For FREE information go to [www.oldhouseonline.com/lit](http://www.oldhouseonline.com/lit)



**House of Antique Hardware**

Discover exquisite Victorian chandeliers, as well as lighting from Colonial to Mid-Century Modern, push button light switches, switch plates, and hardware for every room in your house.

Call their friendly hardware specialists for help with your selection.

888-223-2545; [www.HouseofAntiqueHardware.com](http://www.HouseofAntiqueHardware.com)

For FREE information go to [www.oldhouseonline.com/lit](http://www.oldhouseonline.com/lit)



**Indow Window Inserts**

Window inserts that instantly block cold drafts, increase energy efficiency and hush outside noise. Award-winning design is easy to install and remove. Perfect for historic windows.

503-822-3805; [www.indowwindows.com](http://www.indowwindows.com)

For FREE information go to [www.oldhouseonline.com/lit](http://www.oldhouseonline.com/lit)



**Innerglass Window Systems**

Custom glass interior storm windows for energy conservation and soundproofing. An interior storm that outperforms almost any replacement, yet maintains the integrity and beauty of your historic house. Invisible from the outside.

Perfect for screened porches, too.  
800-743-6207; [www.stormwindows.com](http://www.stormwindows.com)

For FREE information go to [www.oldhouseonline.com/lit](http://www.oldhouseonline.com/lit)

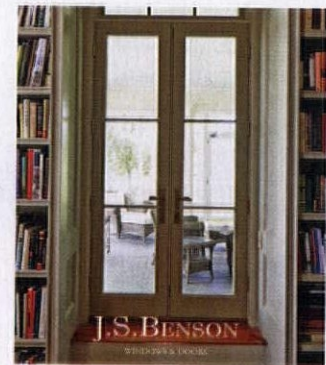

**J.S. Benson Woodworking & Design**

Making the finest custom doors, windows and architectural millwork since 1978.

We manufacture beautiful products that deliver a 100+ year service life with exceptional environmental performance.

802-398-2003; [www.jsbenson.com](http://www.jsbenson.com)

For FREE information go to [www.oldhouseonline.com/lit](http://www.oldhouseonline.com/lit)



**Kennebec Company**

Maine craftsmen build cabinetry and relationships to last a lifetime. Furniture based design and construction in authentic architectural style produce rooms that fit your home and your life.  
207-443-2131; [www.kennebeccompany.com](http://www.kennebeccompany.com)

For FREE information go to [www.oldhouseonline.com/lit](http://www.oldhouseonline.com/lit)



**Lanternland**

**Copper Lanterns & Outdoor Lighting**

Authentic early American, Colonial and Mission style high quality outdoor lighting. Solid copper and brass lanterns and lights handmade in USA. Custom orders and reproductions welcome, easy online ordering, clear up-front pricing, trade discounts, free shipping, choice of finishes + glass, lifetime warranty.

855-454-5200; [www.lanternland.com](http://www.lanternland.com)

For FREE information go to [www.oldhouseonline.com/lit](http://www.oldhouseonline.com/lit)



**Le Mont Hardware**

Elegant Door Furniture and Cabinet Hardware. Bespoke European design in a variety of finishes. Explore the complete Hand-Hammered and Classic collections in our website.

Available only in exclusive showrooms.

[www.lemonthardware.com](http://www.lemonthardware.com)

For FREE information go to [www.oldhouseonline.com/lit](http://www.oldhouseonline.com/lit)

# PRODUCT SHOWCASE



## Marvin Windows and Doors

### NEXT GENERATION ULTIMATE DOUBLE HUNG

With its innovative hardware system and lockable vent mode, this window seamlessly combines revolutionary technology with Marvin's legendary craftsmanship without sacrificing the traditional double hung look.

[www.MarvinWindows.com/DoubleHung](http://www.MarvinWindows.com/DoubleHung)

For FREE information go to [www.oldhouseonline.com/lit](http://www.oldhouseonline.com/lit)



## Mon-Ray, Inc.

For more than 65 years, Mon-Ray, Inc. has been the leader in high performance storm windows for historic projects to conserve energy, reduce noise and retain original appearances. 800-544-3646; [www.monray.com](http://www.monray.com)

For FREE information go to [www.oldhouseonline.com/lit](http://www.oldhouseonline.com/lit)

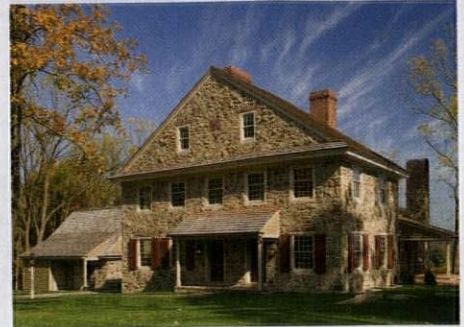

## New Old Homes at Olde Bulltown

Live in a unique settlement of new custom 18th century period homes built by Stoltzfus Enterprises in Chester County, PA. Visit our decorated model home this weekend! 610-533-8938; [www.oldebulltown.com](http://www.oldebulltown.com)

For FREE information go to [www.oldhouseonline.com/lit](http://www.oldhouseonline.com/lit)



## Nostalgic Warehouse

Add instant character and charm to your home with distinctive, vintage-inspired crystal and brass door hardware. Mix & match to create the perfect combination with our virtual hardware designer. Denver, CO.

800-522-7336; [www.NostalgicWarehouse.com](http://www.NostalgicWarehouse.com)

For FREE information go to [www.oldhouseonline.com/lit](http://www.oldhouseonline.com/lit)



## Old House Guy Virtual Design Services

Virtual restorations, makeovers, and paint colors by e-mail. See a photo of your completed project to show your builder, to ensure you get what you want. Visit us online to learn more.

732-455-9499; [www.OldHouseGuy.com](http://www.OldHouseGuy.com)

For FREE information go to [www.oldhouseonline.com/lit](http://www.oldhouseonline.com/lit)



## Osborne Wood Products

Perfect for the Craftsman style kitchen, square profile components are a timeless addition to the home. Incorporate the Craftsman design throughout your space! Learn More: 886-963-5602 [www.dininglegs.com](http://www.dininglegs.com)

For FREE information go to [www.oldhouseonline.com/lit](http://www.oldhouseonline.com/lit)



## OverBoards

OverBoards offers heavy-duty, solid extruded aluminum covers for baseboard heat units. They're made to complement your home's classic architectural details.

800-835-0121; [www.go-overboard.com](http://www.go-overboard.com)

For FREE information go to [www.oldhouseonline.com/lit](http://www.oldhouseonline.com/lit)



## Pro Wood Market

US Made Cedar Architectural Accents Brackets, Braces, Corbels, Rafter Tails, Porch and Gable Brackets, Screen Doors, Shutters, Post Caps Mantels and more. We do custom work. Shipped nationwide. (shown here, Wooden Bracket and Corbel) 800-915-5110; [www.prowoodmarket.com](http://www.prowoodmarket.com)

For FREE information go to [www.oldhouseonline.com/lit](http://www.oldhouseonline.com/lit)



## Raw Urth

Beautifully and artfully handcrafted range hoods, made one at a time in Northern Colorado. They add style, charm and flare to any kitchen.

Available in a variety of metals. 866-932-7510; [www.rawurth.com](http://www.rawurth.com)

For FREE information go to [www.oldhouseonline.com/lit](http://www.oldhouseonline.com/lit)

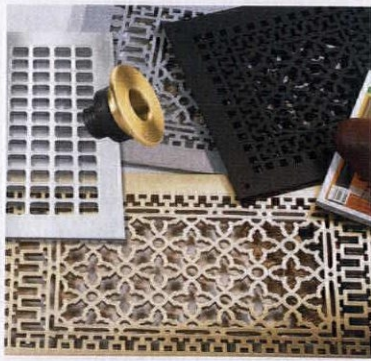

### The Reggio Register Company

Attractive, heirloom quality, cast iron, brass, aluminum and steel grilles. Historic and contemporary designs for forced air and high velocity systems available in a huge selection of sizes and materials.

800-880-3090; [www.reggioregister.com](http://www.reggioregister.com)

For FREE information go to [www.oldhouseonline.com/lit](http://www.oldhouseonline.com/lit)



### SRS Hardware

Whether you are restoring old or building new, our hardware will ensure your windows work perfectly. Visit [srshardware.com](http://srshardware.com) to see all of our window restoration supplies including Samson Red Spot sash cord and Acro numbering tacks

[www.srshardware.com](http://www.srshardware.com)

For FREE information go to [www.oldhouseonline.com/lit](http://www.oldhouseonline.com/lit)



### Stickley

Stickley's 2015 Collector Edition is the Gus Woven Leather Bench, featuring a blend of rich leather, nail-head trim and pinned tenon construction. Available in solid quartersawn white oak or solid cherry, this bench will only be built in 2015. Sale price \$999. Visit [Stickley.com](http://Stickley.com).



### Sylvan Brandt

We've been supplying antique flooring since 1960. Our flooring is either reclaimed from old houses or is sawn from vintage beams, and captures the natural beauty and patina from wood that may have been demolished.

717-626-4520; [www.sylvanbrandt.com](http://www.sylvanbrandt.com)

For FREE information go to [www.oldhouseonline.com/lit](http://www.oldhouseonline.com/lit)



### Timberlane, Inc.

Quality is what makes Timberlane the choice of architects, decorators, contractors, builders, renovators, and homeowners. Timberlane offers a near infinite number of options for standard shutters as well as fully custom solutions, and the largest collection of hand-forged, period-perfect shutter hardware available.

800-250-2221; [www.timberlane.com](http://www.timberlane.com)

For FREE information go to [www.oldhouseonline.com/lit](http://www.oldhouseonline.com/lit)



### Ultra Aluminum Mfg., Inc.

Ultra Aluminum has created a new product line, the Ultra Estate Collection, manufacturing finely crafted gates, railing and fence with all the appeal of wrought iron, but none of the traditional maintenance.

800-656-4420; [www.ultrafence.com](http://www.ultrafence.com)

For FREE information go to [www.oldhouseonline.com/lit](http://www.oldhouseonline.com/lit)



### Vermont Soapstone

Since 1856 Vermont Soapstone has been crafting the finest custom soapstone counter tops, sinks, floor tiles and home accents. Durable and timeless soapstone never stains or retains bacteria. Installation is available.

800-284-5404; [www.vermontsoapstone.com](http://www.vermontsoapstone.com)

For FREE information go to [www.oldhouseonline.com/lit](http://www.oldhouseonline.com/lit)

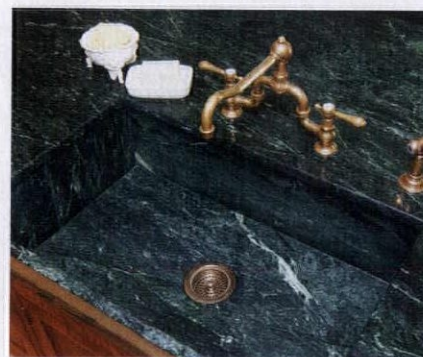

### Vermont Verde Antique

Quarried in Vermont. The world's finest serpentine stone is acid and stain resistant, hard, durable, and low maintenance.

An excellent choice for countertops, shower enclosures, fireplace surrounds, and floors.

802-767-4421; [www.vtverde.com](http://www.vtverde.com)

For FREE information go to [www.oldhouseonline.com/lit](http://www.oldhouseonline.com/lit)



### Vintage Kitchen Stoves

Established in 1973

We restore and convert antique stoves, gas, electric or a combination. No reproductions but original historic American treasures adapted to meet today's modern cooking and baking conveniences. Customized Conversion to meet the most demanding cooking needs.

413-268-3677, [GoodTimeStove.com](http://GoodTimeStove.com)

For FREE information go to [www.oldhouseonline.com/lit](http://www.oldhouseonline.com/lit)



### Vintage Doors

Handcrafted solid wood doors that are made-to-order and built to last. Full line of screen/storm doors, porch panels, exterior and interior doors, Dutch, French, louver and more. Make your home stand out from the rest!

800-787-2001; [www.vintagedoors.com](http://www.vintagedoors.com)

For FREE information go to [www.oldhouseonline.com/lit](http://www.oldhouseonline.com/lit)



### Vintage Hardware & Lighting

Huge selection. Many unique products. The perfect choice for your vintage hardware and lighting needs. American and European designs spanning decades of history. We also do custom designs and sell antique fixtures and shades.

360-379-9030; [www.vintagehardware.com](http://www.vintagehardware.com)

For FREE information go to [www.oldhouseonline.com/lit](http://www.oldhouseonline.com/lit)



### Ward Clapboard Mill

Authentically produced, 100-percent vertical-grain, early American spruce and pine clapboards. Their mills in Maine and Vermont continue to manufacture quality logs into quarter-sawn clapboards with the same methods workers used more than a hundred years ago.

802-496-3581; [wardclapboard.com](http://wardclapboard.com)

For FREE information go to [www.oldhouseonline.com/lit](http://www.oldhouseonline.com/lit)



### West System: Six10®

A two-part thickened epoxy in a convenient cartridge. Use for permanent, waterproof, structural gap-filling and gluing. Works on wood, fiberglass, metals and masonry.

Adhesive dispensed on-ratio with a standard caulking gun.

[www.westsystem.com](http://www.westsystem.com)



### Western Spindle

Specializing in custom and reproduction porch rail, spindles (balusters), and other millwork, especially for Victorian-style architecture.

Available in premium exterior wood or high density polyurethane.

888-459-9965; [www.westernspindle.com](http://www.westernspindle.com)

For FREE information go to [www.oldhouseonline.com/lit](http://www.oldhouseonline.com/lit)

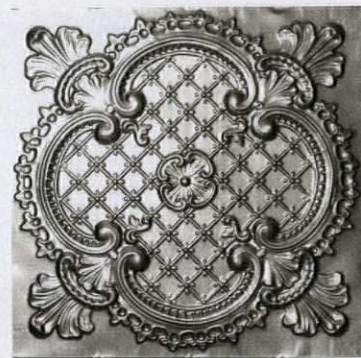

### W.F. Norman Corporation

Founded in 1898, W. F. Norman Corp. has the nation's most complete collection of quality, hand pressed ceilings, cornices, moldings, and ornaments. Call today for our catalog or view our products online!

800-641-4038; [www.wfnorman.com](http://www.wfnorman.com)

For FREE information go to [www.oldhouseonline.com/lit](http://www.oldhouseonline.com/lit)

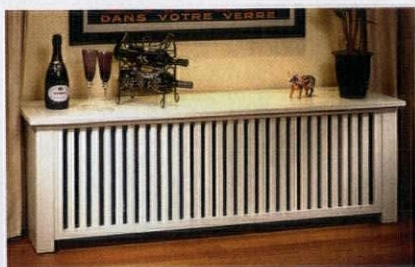

### Wooden Radiator Cabinet Company The Perfect Cover-Up!

The Wooden Radiator Cabinet Company provides the finest custom-built cabinets in the country, turning eyesores into elegant and functional furniture.

We offer durable, elegant and affordable radiator and baseboard covers, PTAC, fan coil covers and bookcases from classic to contemporary. Just push them in place for an elegant cabinet or window seat.

800-817-9110; [woodenradiatorcabinet.com](http://woodenradiatorcabinet.com)

For FREE information go to [www.oldhouseonline.com/lit](http://www.oldhouseonline.com/lit)

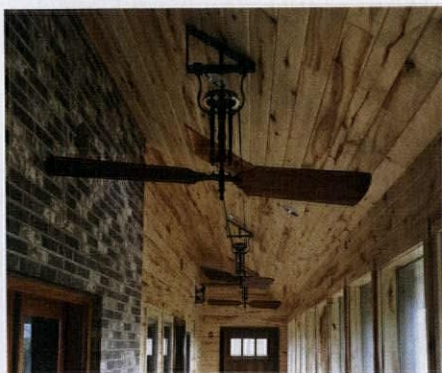

### Woolen Mill Fan Company

Woolen Mill fans are crafted in a rural studio using real iron, solid bronze and solid mahogany wood blades. Visually they compliment both historical as well as contemporary room designs

717-382-4754; [www.architecturalfans.com](http://www.architecturalfans.com)

For FREE information go to [www.oldhouseonline.com/lit](http://www.oldhouseonline.com/lit)



### Wooster Furry Paint Roller

Finish as smooth as ice! Wooster Polar Bear® has unique, plush fabric for huge time savings, very low lint. One universal pile height covers light to very textured surfaces. Use with flat, eggshell or satin paints, primers, and metallics.

800-392-7246; [www.woosterbrush.com](http://www.woosterbrush.com)

For FREE information go to [www.oldhouseonline.com/lit](http://www.oldhouseonline.com/lit)



### A PRESERVATION TALE

#### CONTRACTOR

**Scott W. Brown & Son**, Bayshore, NY: (631) 277-7605

#### INTERIOR DESIGN/

#### ANTIQUE RESTORATION

**Belle Interiors LLC**, East Moriches, NY [belleinteriors.com](http://belleinteriors.com)

#### EXTERIOR PAINT

Body 'Beacon Hill Damask'; Trim 'Davenport Tan'; Shutters '2054-10', all from **Benjamin Moore** [benjaminmoore.com](http://benjaminmoore.com)

#### ANTIQUES

**Morgan Macwhinnie Antiques**, Southampton, NY (631) 283-3366  
**John Scudder & Mary Pelletreau Havens Homestead Museum Shop**, Center Moriches, NY: (631) 878-1855

#### LAMP SHADES ETC.

**KC Collections**, Eastport, NY [kcineastport.com](http://kcineastport.com)

#### HISTORICAL SITE

**Ketcham Inn**, Ketcham Inn Foundation, Inc., Center Moriches, NY [ketchaminn.org](http://ketchaminn.org)

#### Related Resources

#### EXTERIOR SHUTTERS

**Designer Doors** [designerdoos.com](http://designerdoos.com) wood shutters in historic designs  
**Shuttercraft** [shuttercraft.com](http://shuttercraft.com) louver, raised-panel, board-and-batten shutters  
**Timberlane Inc.** [timberlane.com](http://timberlane.com) wood louver, batten & panel shutters

#### VICTORIAN MILLWORK

**Pro Wood Market** [prowoodmarket.com](http://prowoodmarket.com) wooden exterior architectural products  
**Western Spindle** [westernspindle.com](http://westernspindle.com) custom wood spindles, balusters, etc.

#### LIGHTING

**House of Antique Hardware** [houseofantiquehardware.com](http://houseofantiquehardware.com) fixtures in many finish & shade options  
**Victorian Lighting Works** [vlworks.com](http://vlworks.com) Reproduction Victorian and turn-of-the-century lighting

#### STOVES

**Elmira Stove Works** [elmirastoveworks.com](http://elmirastoveworks.com) antique- & retro-look stoves

#### VICTORIAN HARDWARE

**Crown City Hardware** [restoration.com](http://restoration.com) Victorian-era reproductions in brass  
**House of Antique Hardware** [houseofantiquehardware.com](http://houseofantiquehardware.com) period hardware collections  
**Le Mont Hardware** [lemonthardware.com](http://lemonthardware.com) door & furniture hardware in classic styles  
**Vintage Hardware & Lighting** [vintagehardware.com](http://vintagehardware.com) reproduction hardware

#### TAILORING A FOURSQUARE

#### DESIGNERS

**David Heide Design Studio** [dhdstudio.com](http://dhdstudio.com)

#### CABINETMAKER

**George Wurtzel**, Minneapolis, MN: [gmwurtzel.com](http://gmwurtzel.com)

#### STONE FLOORING

**AKDO** [akdo.com](http://akdo.com)

#### HARDWARE

**Top Knobs** [topknobs.com](http://topknobs.com)  
**Bosetti-Marella** [classichardwareusa.com](http://classichardwareusa.com)  
*Note: much of the lighting and hardware is original or vintage*

#### Related Resources

#### HARDWOOD FLOORING

**Colonial Plank Floors** [colonialplankfloors.com](http://colonialplankfloors.com) flooring in red or white oak, cherry, hickory  
**Sylvan Brandt** [sylvanbrandt.com](http://sylvanbrandt.com) antique and re-sawn pine, chestnut oak flooring

#### KITCHEN TILE

**Subway Ceramics by Heritage Tile** [subwaytile.com](http://subwaytile.com) reproduction subway tile

#### SOAPSTONE COUNTERS

**Bucks County Soapstone** [bcsoapstone.com](http://bcsoapstone.com) soapstone counters & sinks  
**Vermont Soapstone** [vermontsoapstone.com](http://vermontsoapstone.com) custom soapstone sinks & countertops

#### GASLIGHT/TRANSITIONAL LIGHTING

**PW Vintage Lighting** [pwvintagelighting.com](http://pwvintagelighting.com) traditional lighting from the 1840s on  
**Vintage Hardware & Lighting** [vintagehardware.com](http://vintagehardware.com) reproduction lighting; custom fabrication

#### AESTHETIC MOVEMENT WALLPAPERS

**Bradbury & Bradbury** [bradbury.com](http://bradbury.com) hand silk-screened art wallpapers in designs from Victorian to Mid-century Modern  
**Mason & Wolf** [mason-wolf.com](http://mason-wolf.com) silk-screened roomset papers in Aesthetic Movement designs

#### MAKEOVER FOR A MODEST KITCHEN

**FLOORING INSTALLER**  
**Matthew S. Faulkner**, Portland: (503) 577-9153

#### TILE INSTALLER

**Tony Rotar, Inter Tile Inc.**, Portland: (503) 819-5762

#### COUNTERTOPS

**Rick Canfield, Alpha Stoneworks**, Portland: [alphastoneworks.com](http://alphastoneworks.com)

#### FLOORING

**Marmoleum by Forbo**, through Contract Furnishings Mart, Portland: [cfmfloors.com](http://cfmfloors.com)

#### FAUCET

**Culinary Depot, Inc.** [culinarydepotinc.com](http://culinarydepotinc.com)

#### PAINT

**Miller Paint** [millerpaint.com](http://millerpaint.com)



# HISTORIC HOME SHOW

FEBRUARY 5-7, 2016  
VALLEY FORGE CASINO RESORT  
CONVENTION CENTER  
KING OF PRUSSIA, PA

*The only national event dedicated to restoring, renovating, and furnishing traditional and historical homes*

#### OLD HOUSE UNIVERSITY

Friday, Feb. 5: 1-5 pm  
Editor Patricia Poore and esteemed guests discuss how to plan additions, kitchens & revival interiors, as well as the basics of DIY home ownership. Bring your questions! \$89/129 for two (Price includes admission to show all 3 days).

#### OPENING NIGHT

**PREVIEW & RECEPTION**  
Friday, Feb. 5: 6-9 pm  
Admission: \$20 per person, \$30 for two. \$5 off admission with this coupon.

#### EXHIBITS, CRAFT DEMONSTRATIONS & WORKSHOPS

Saturday, February 6:  
10 am-5 pm  
Sunday, February 7:  
11 am-4 pm  
Admission \$10 when you preregister, \$12 on-site. \$2 off admission with this coupon.

For more information visit [www.historichomeshows.com](http://www.historichomeshows.com)

# Remuddling



“Empires rise and fall...this one fell hard.”

—Emma Leigh



## NEGLECT NOT SO BENIGN

“A mansard muddle,” sighs Rebecca, the reader who snapped these photos of side-by-side Second Empire houses. The handsome homes were built in New England during the mid Victorian period. Both became apartment houses sometime in the 20th century. But changing fortunes and adaptive reuse don’t have to mean uglification!

Well maintained, the tower house retains its dignity; mandated fire stairs are on its back side. The mansard-roofed villa, in contrast, is suffering from flagrant disrespect.

“Which house would you prefer to live in?” Rebecca asks. For most of us, the answer would be the house well cared-for. We might surmise that there’s a correlation between how one treats an old building (and the neighborhood) and how one treats the tenants. Buildings talk.

## DO

...keep up appearances. Neighborhoods thrive or decay on their building stock. Here, original massing is intact along with details that delight. The roof is sound, the paint job sympathetic.

**TWO WAYS TO WIN!** If you spot a classic example of remuddling, submit it at [oldhouseonline.com/remuddling](http://oldhouseonline.com/remuddling). We’ll give you \$100 if your photos are published. If you want to see your witty words on this page, enter our monthly caption contest at [facebook.com/oldhousejournal](https://www.facebook.com/oldhousejournal).



Custom. Period.  
Designed. Delivered. Direct.

800-999-4994 • [www.crown-point.com](http://www.crown-point.com)

CROWNPOINT  
CABINETS

Fine Quality Custom Cabinetry  
Handcrafted For Your Entire Home

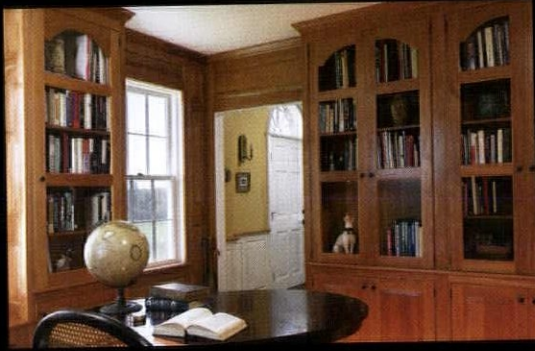

# CONNOR HOMES

(802) 382-9082 • [www.connorbuilding.com](http://www.connorbuilding.com)