

"WHEN IT'S 'INCOR' IT'S —

# Watertight"

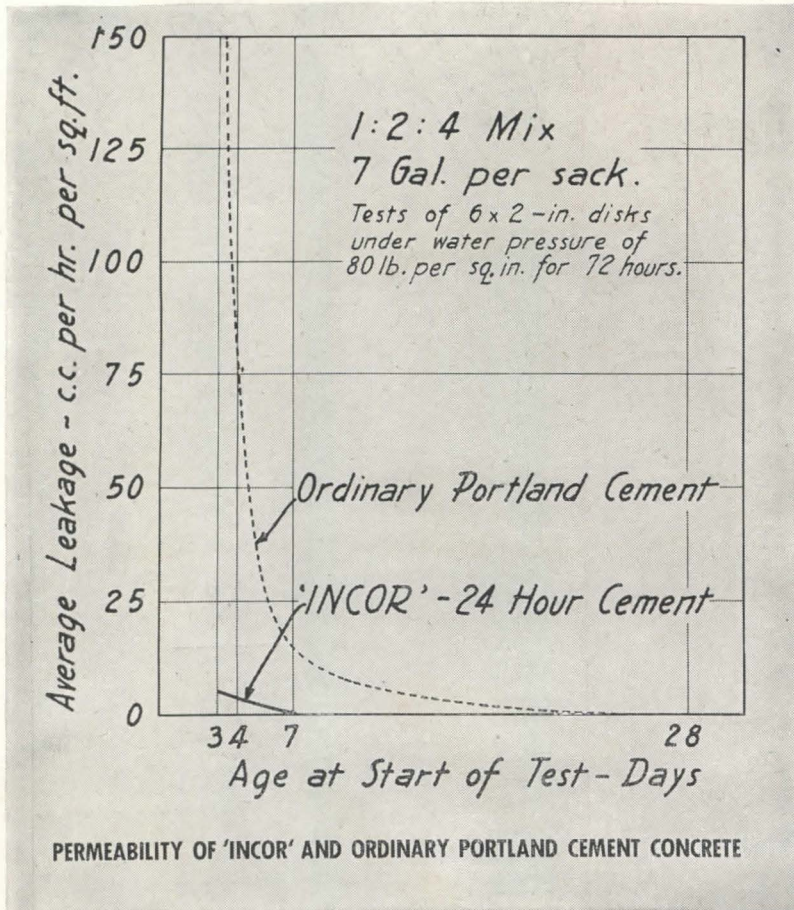

GOOD concrete is watertight, of itself and by itself. Use a well-designed mix, place carefully, CURE THOROUGHLY. With ordinary cement, thorough curing means keeping concrete wet a week or longer . . . next to impossible on most jobs. 'INCOR' 24-HOUR CEMENT solves this problem, by curing THOROUGHLY in 24-48 hours instead of 6-8 days. Tests in Lone Star Cement Research Laboratory, summarized in graph, show practically no leakage with 3-day-old 'Incor' concrete . . . ten days to equal this with ordinary cement.

"When it's 'Incor', it's watertight" — 20 years' performance in swimming pools, tanks, water works and other structures, proves it! Use America's FIRST high early strength Portland Cement — get added assurance of watertightness and durability — cut curing time and costs. \*Reg. U. S. Pat. Off.

(Below) Water Purification Plant, Albany, Mo., concreted with 'Incor'. Contractor, Don Pray, Monett, Mo.; Engineers, E. T. Archer & Co., Kansas City, Mo.

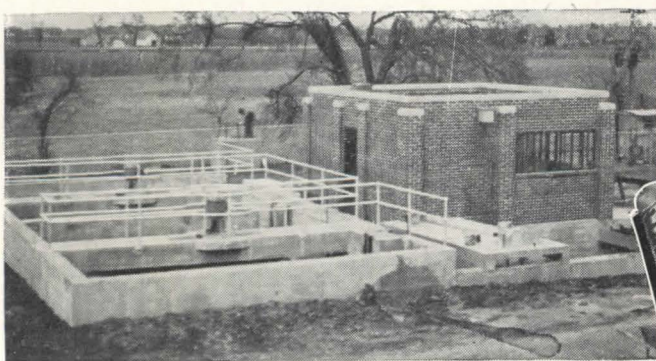

## LONE STAR CEMENT CORPORATION

Offices: ALBANY • BETHLEHEM, PA. • BIRMINGHAM • BOSTON • CHICAGO • DALLAS • HOUSTON • INDIANAPOLIS • JACKSON, MISS. • KANSAS CITY, MO. • NEW ORLEANS • NEW YORK • NORFOLK • PHILADELPHIA • ST. LOUIS • WASHINGTON, D. C.

LONE STAR CEMENT, WITH ITS SUBSIDIARIES, IS ONE OF THE WORLD'S LARGEST CEMENT PRODUCERS: 15 MODERN MILLS, 25,500,000 BARRELS ANNUAL CAPACITY





# Wiley

*In construction products* **CECO ENGINEERING**



# Concrete Joist Construction?

Because Today's Costs are NOT Out of Line . . . Because, strength and durability considered, concrete joist construction is the most economical way to build . . .

In these days of high costs, economy in building is important, provided strength and durability are not sacrificed. Here is where concrete joist construction comes in—since it provides rigid, strong, sound-proof buildings which are fire resistive, yet construction cost is lower. That is because the amount of concrete and, consequently, the dead load, are kept to a minimum for any span or live load. The concrete joist and monolithic top slab are formed with cores of removable Meyer steelforms, supported on skeleton centering. Once the concrete has set, the forms are removed and re-used from floor to floor and from job to job. Therefore, a nominal rental charge can be made for each use. Construction is speeded up.

## WHY SPECIFY CECO?

Ceco originated the removable steelform method of concrete joist construction. The company is first in the field—actually providing more services than all competitors combined. So, when concrete joist construction fits your need, call on Ceco, the leader over all. Thirty five years of experience in the field, on the job, have given Ceco a sure grasp of all concrete joist construction problems. This fund of knowledge is yours to command, in 23 strategically located offices from coast to coast.

### CECO STEEL PRODUCTS CORPORATION

GENERAL OFFICES: 5701 W. 26th Street, Chicago 50, Illinois

Offices, warehouses and fabricating plants in principal cities

See Ceco catalogs in Sweet's Architectural File or send for free descriptive literature

**CECO  
STEEL**

*makes the big difference*

## 4 STEPS TO REDUCE BUILDING COSTS...



Money Saver Step No. 1

Meyer steelforms completely erected on open wood centering, ready for placement of reinforcing steel and concrete. Note column spirals awaiting installation in columns. Ceco engineers lay out and supervise the complete installation of steelforms on open wood centering.



Money Saver Step No. 2

In this photograph, the reinforcing bars are installed as detailed by Ceco, in proper relation to the erected steelforms. Now the job is ready for placement of the temperature mesh in the top slab. This mesh reinforcement is also supplied by Ceco.



Money Saver Step No. 3

Here the mesh, also known as welded wire fabric, has been placed in correct position and the pouring of concrete for the top slab has commenced. In Ceco-erected jobs such as this, the design is carefully engineered to assure proper reinforcement throughout the structure.

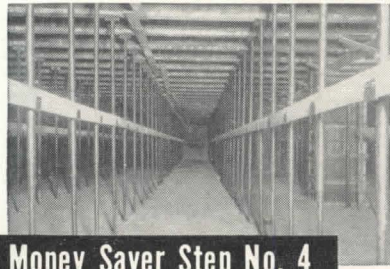

Money Saver Step No. 4

Underneath the concrete joists, Meyer adjustable steel shores support the open wood centering. Forming the floor construction above are adjustable-type steelforms nailed to the centering. Also available are flange-type steelforms, used when plastered ceilings are to be installed.

### Partial list of other Ceco Products:

STEEL JOISTS AND ROOF DECK  
METAL WINDOWS AND DOORS  
METAL FRAME SCREENS • ALUMINUM  
STORM PANELS • METAL LATH AND  
ACCESSORIES • HIGHWAY PRODUCTS  
CORRUGATED ROOFING • LOUVRE  
VENTILATORS





*Going everywhere ... Doing everything*  
**RADIANT HEATING with**  
**BYERS WROUGHT IRON PIPE**

If you are thinking of making a radiant heating installation in any type of structure, you'll probably see its counterpart here . . . for designers have successfully used this modern method of heating in everything from homes to dog kennels, and from hangars to reptile houses. And you'll find the wealth of practical, authentic engineering data, collected by A. M. Byers on a thousand-and-one installations, a welcome help in planning and successfully completing the jobs with which you are concerned.

In the thousands of systems now serving in 45 of the 48 states, one

material is an overwhelming favorite . . . Byers Wrought Iron Pipe. For designers have discovered that it provides a combination of four essential qualities; ease of fabrication; high heat emission; good thermal characteristics; and *proven* corrosion resistance. Do you have our bulletin, "Wrought Iron for Radiant Heating?" We will be glad to send you a complimentary copy.

A. M. Byers Co., Pittsburgh, Pa. Established 1864. Boston, New York, Philadelphia, Washington, Atlanta, Chicago, St. Louis, Houston, Salt Lake City, Seattle, San Francisco.

*Corrosion costs you more than wrought iron*

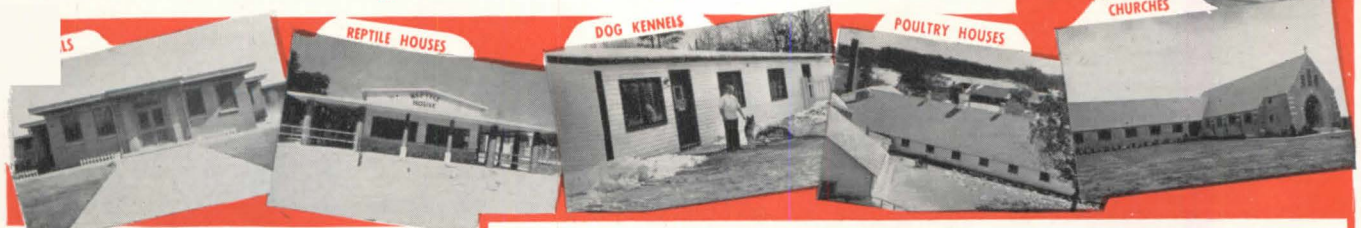

"ETERNALLY YOURS"—professionally-produced 16mm sound motion picture. An entertaining saga of the wrought iron industry, available to technical groups. New, authentic, informative. Write Modern Talking Picture Service, Inc., 9 Rockefeller Plaza, N.Y. 20, N.Y.

**BYERS**  
**GENUINE WROUGHT IRON**  
**TUBULAR AND HOT ROLLED PRODUCTS**  
 ELECTRIC FURNACE QUALITY ALLOY AND STAINLESS STEEL PRODUCTS



ARCHITECTURAL  
RECORD

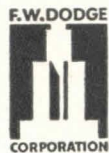

Copyright 1947 with all rights reserved F. W. DODGE CORPORATION • Vice-President in charge of Magazine Division, H. Judd Payne • **EDITORS:** Editor-in-Chief, Kenneth Kingsley Stowell, A.I.A.; Managing Editor, Emerson Goble; Senior Associate Editor, Douglas Haskell; Associate Editors, John W. Ragsdale, James S. Graham, Jr.; Associate in South America, Edmund J. Whiting, A.I.A.; News Editor, Florence A. van Wyck • **ART DEPARTMENT:** Myron S. Hall, 3rd, Director; Peter Piening, Consultant; Sigman-Ward, Drafting • **CONSULTANTS:** Industry Relations Consultant, Thomas S. Holden; Statistical Consultant, Clyde Shute; Building Economics Consultant, Norbert Brown; Field Research Consultant, Clifford Dannels, Jr.

**PLANNING, TOO, IS FOR PEOPLE** . . . . . 67  
An Editorial . . . by Kenneth K. Stowell

**THEY PLANNED IT THAT WAY** . . . . . 68  
From a Quaint, Provincial Town, Zlin, Czechoslovakia, Developed into a Completely Integrated Industrial City. By Jan Pokorny and Elizabeth Hird

**TREE-SET IN TEXAS** . . . . . 76  
Home of I. Herschel Fisher, Architect, of Wiltshire and Fisher, Architects, Dallas

**A CENTER FOR MOTHERS AND INFANTS** . . . . . 79  
Tacubaya, D. F., Mexico. Enrique de la Mora, Architect

**BUILDING TYPES STUDY NO. 128 . . . INDUSTRIAL BUILDINGS** . . 85

**THE ARCHITECT'S OPPORTUNITIES IN FACTORY DESIGN** . . . . 86  
By Roland A. Wank

**NEWEST OF JOHNSON & JOHNSON FACTORIES** . . . . . 91  
Baby Products Plant, Cranford, N. J. The Ballinger Co., Architects and Engineers; John A. Johnson and Sons, Brooklyn, General Contractors

**MODERN PRESCRIPTION FOR INFANT INDUSTRY** . . . . . 96  
Semple Machine Shop, Near St. Louis. Harris Armstrong, Architect

**ECONOMICAL DESIGN RETAINS AMENITY VALUES** . . . . . 98  
B H Aircraft Plant, Islip, L. I. Petroff and Clarkson, Architects; Robert H. Edwards, Associate Architect

**DESIGNED FOR DUST AND GERM CONTROL** . . . . . 100  
Ampul Building for Winthrop Chemical Co., Rensselaer, N. Y. The Austin Co., Engineers and Builders

**ARCHITECTURAL ENGINEERING** . . . Technical News and Research . . . 103

**INDUSTRIAL PLANTS—A HARVARD RESEARCH PROJECT** . . . . 103  
By Walter F. Bogner

**TIME-SAVER STANDARDS** . . . . . 115  
Economical Steel Framing Details: Suggestions of American Institute of Steel Construction for Small Industrial Buildings

**PRODUCTS** . . . for Better Building . . . . . 122

**MANUFACTURERS' LITERATURE** . . . . . 124

**THE RECORD REPORTS** . . . News from the Field . . . . . 7

**LETTERS FROM RECORD READERS** . . . . . 20

**CONSTRUCTION COST INDEXES** . . . . . 27

**REQUIRED READING** . . . . . 28

**EMPLOYMENT OPPORTUNITIES** . . . . . 182

**INDEX TO ADVERTISEMENTS** . . . . . 200

Architectural Record (combined with American Architect and Architecture) is published monthly by F. W. Dodge Corporation, 10 Ferry St., Concord, N. H., with Editorial and Executive Offices at 119 West 40th Street, New York, N. Y. Thomas S. Holden, Pres.; Howard J. Barringer, Vice-Pres. and Treas.; Irving W. Hadsell, Vice-Pres.; Chauncey L. Williams, Vice-Pres.; Sanford D. Stockton, Jr., Secy.; Walter F. De Saix, Asst. Treas.; Edwin H. Freed, Asst. Treas. Member Audit Bureau of Circulation and Associated Business Papers, Inc. Architectural Record is indexed in Reader's Guide, Art Index and Industrial Arts Index. Subscription rates: United States and Possessions, Canada, Cuba, Mexico, Central and South America, and Spain, \$4.50 the year, \$7.50 for two years, \$9 for three years; elsewhere, \$6.50 the year, \$11.50 for two years, \$15 for three years. Single copy, \$1. Circulation Manager: Marshall T. Ginn. Every effort will be made to return material submitted for possible publication (if accompanied by stamped, addressed envelope), but the editors and the corporation will not be responsible for loss or damage. Other Dodge Services: Real Estate Record & Builders' Guide, Sweet's Files, Home Owners' Catalogs, Dodge Reports & Dodge Statistical Research Service.



# NEW development for hospitals

## ... Watrous Flush Valves with Integral Drip Receptor

In hospitals, the use of special fittings to clean bed pans presents the problem of drippings every time the fitting is used.

Here is a simple common-sense answer now offered by Watrous. It consists of a drip receptor mounted as an integral part of the flush valve. The cleaning nozzle is simply placed in this holder after use, and any accumulated drippings flow through a check valve into the flush connection and down into the bowl.

The use of this new Watrous combination eliminates the expense of specially constructed bowls or tanks, and keeps the fittings and hose up out of the way. It is thoroughly protected against any spilling and back-siphonage, and can be arranged for any height above the bowl.

The flush valve itself, of course, offers all those basic Watrous superiorities—self-cleansing by-pass, water-saver adjustment, self-tightening handle packing, single-step-servicing, and, at slight additional cost, screenless silent-action.

Keep this in mind for whatever flush valve needs you may have — Watrous means maximum convenience and economy.

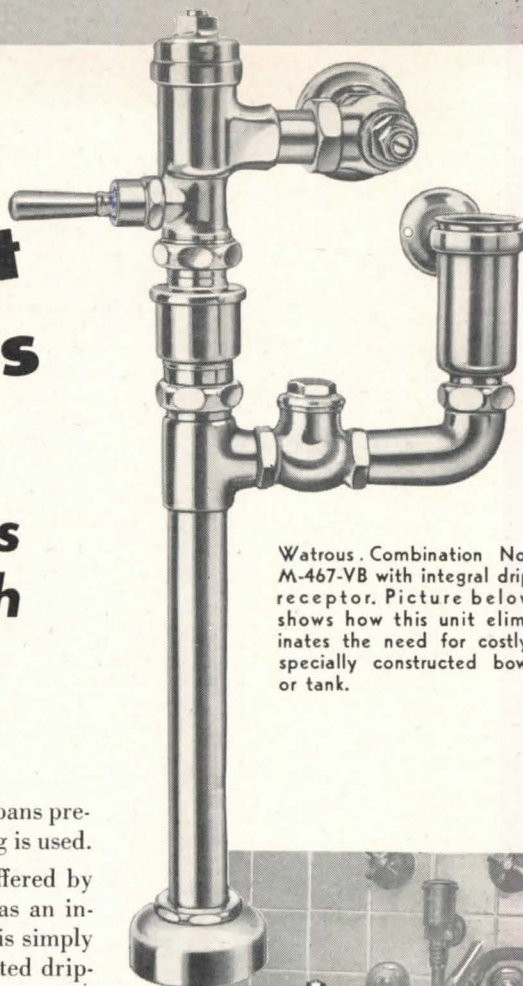

Watrous Combination No. M-467-VB with integral drip receptor. Picture below shows how this unit eliminates the need for costly, specially constructed bowl or tank.



THE IMPERIAL BRASS MANUFACTURING COMPANY

1240 W. Harrison St., Chicago 7, Ill.

For complete information on Watrous Flush Valves see Sweets' Catalog or write for Catalog No. 448-A. Also ask for Bulletin No. 447 giving a summary of "Architects' Views on Flush Valve Applications."



... Survey shows  
**7** out of **8**  
Architects Prefer  
Adjustable  
Flush Valves

# Watrous

# Adjustable Flush Valves

BOTH DIAPHRAGM AND PISTON TYPES



# THE RECORD REPORTS

## Labor Act May Create New Construction Difficulties Truman Urges Housing Probe • Congress Hits Federal Housing Agencies Hard • Mortgage Credit Is Tighter

In the wake of Uncle Sam's practical abandonment of building controls, new construction uncertainties arise from federal quarters. There's the highly complicated labor law written onto the statute books over the President's veto, which most think will bring trouble. Too, there are moves to probe conditions in the housing industry.

The attitude of employers' groups in the construction industry roughly is that dealing with unions means suffering every kind of imposition, but that fighting with unions is no picnic. The impositions include occasional jurisdictional strikes, outlawed by the Act. They include kinds of on-site labor that, according to the employers, are as pure a distillation of featherbedding as anybody ever could find: limits on the number of bricks to be placed per hour; on-job instead of in-factory threading of pipes; four journeymen plumbers to tote a bathtub from truck to bathroom; 3-in. maximum on width of house-painter brushes, etc. — all these varying endlessly from town to town. They feel that their industry almost was made in anticipation of the new law, which forbids the things they complain of.

### New Rulings Possible

But now that the Act has been passed, employer spokesmen still feel that, bad as everything may be, corrections will not be applied without trouble. Some don't even want to see the new law applied. They are hopeful that it will not be, by virtue of older NLRB rulings classifying on-site construction as intra-state. Such rulings came about, bluntly, simply because employer-union relations had long been established and nobody wanted to upset them. Unions did not press cases charging unfair practice; they had their closed shops anyway from away back.

But both sides are far from sure that nobody will upset things now. There may be a jurisdictional strike somewhere. The contractor may press his case before the NLRB. If the strike affects a factory, say, whose products cross state lines, NLRB may invade the construction industry. Then more cases may appear and the Board — or a Court — may reverse the old point of view.

Closed shops are prevalent, and now they are outlawed. As long as NLRB lets construction remain intra-state, nothing will happen. But contractors

imagine a non-union-member suing, or going before the Board, to demand a job. This could raise the issue. Everybody so far prefers to keep quiet.

### Housing Probe Wanted

President Truman and Senator Taft, while political opponents, agreed on the need of a real estate probe. The President, in a critical message to Congress on the rent control bill, which he reluctantly signed, spoke out bluntly:

"It is intolerable that this (real estate) Lobby," he said, "should be permitted by its brazen operations to block programs so essential to the needs of our citizens. Nothing could be more clearly subversive of representative government. I urge the Congress to make a full investigation of this selfish and short-sighted group."

The Ohio Senator's agreement followed his earlier remarks to a housing rally that misleading propaganda about the Wagner-Ellender-Taft housing bill had been distributed to members of Congress by the home builders and real estate associations.

Meanwhile the House Labor Committee, charging racketeering and monopoly in the housing and construction industry, named a sub-group to inquire into "material and labor costs and questionable practices relating to the economics of housing and construction generally" as well as "numerous complaints of abuses that

are paralyzing the building business."

Representative Gwinn of New York, who heads the sub-group (other members include Representatives Owens of Illinois and Lucas of Texas), advises that he will delve into efforts toward collectivism through increased federal housing programs.

### Housing Units Hit

Congress in its closing weeks pelted and pared the federal housing activities left and right. In its government corporations bill it whacked the housing agencies by millions of dollars. Regarding the Office of Administrator, the House Appropriations Committee commented that "unless legislative provision is made to authorize and specify (its) duties and functions . . . the fiscal year 1948 is to be the last year of its existence." It spoke of the Housing Expediter's activities even more critically: "The Committee is convinced that the program of trying to expedite the construction of residential housing has not been successful. It is doubtful that the funds expended have expedited construction at all, and more doubtful that the public has received real value for its funds so used." It rained charges on the Federal Public Housing Authority and questioned its policies and methods in disposing of war housing, especially sales to mutual ownership groups.

Buried in the government corporation bill report was the recommendation that a Congressional committee re-examine the ratio of reserves maintained against loss contingencies under FHA operations in insuring loans. The suggestion is made because the agency has been operating in a period when real property values were rising and has never been confronted with a period of declining residential prices.

(Continued on page 10)

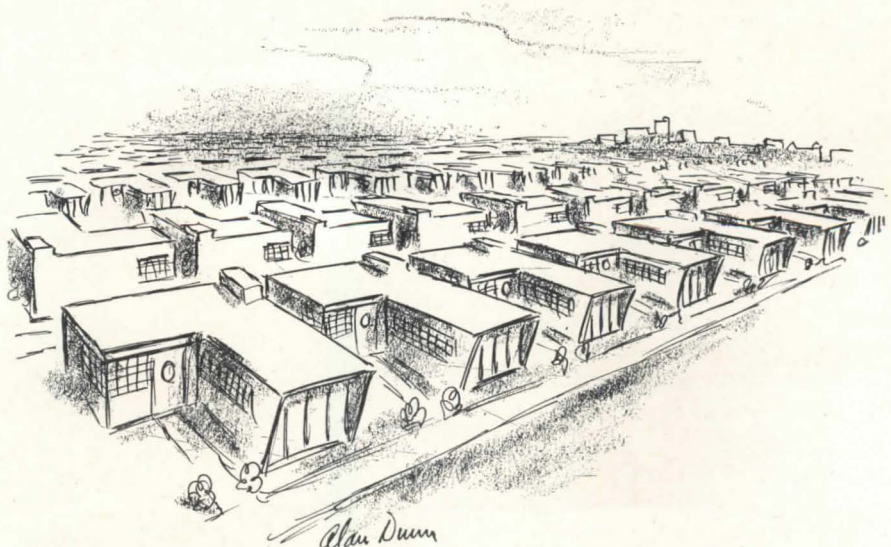

— Drawn for the RECORD by Alan Dunn



# "LET THERE BE LIGHT"



*FORD Sales and Service, Detroit, Michigan*

*Architect: O'Dell, Hewlett & Lukenbach*

*Electrical Contractor: Wayne Electric Co.*

*Fixture Manufacturer: Kirlin Company*

*Corning Lightingware: ALBA-LITE Panels*

*Foot Candles Delivered: 40 to 55*

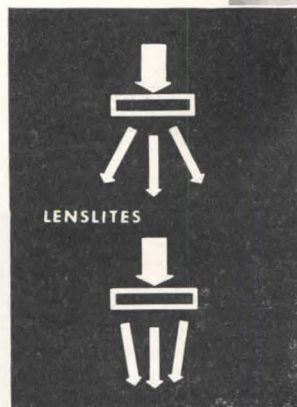
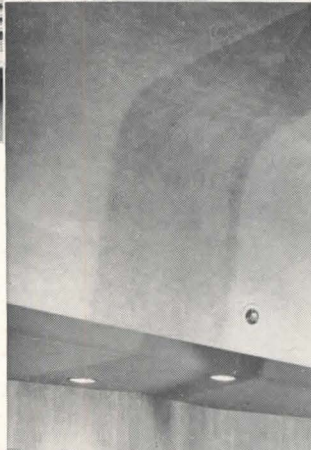
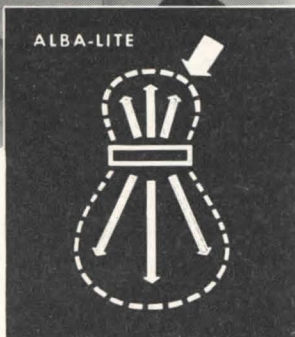

*Western Air Lines, Los Angeles, California*

*Architect: H. Roy Kelley*

*Contractor: Golden State Electric Company*

*Fixture Manufacturer: Wagner—Woodruff Company*

*Corning Lightingware: PYREX brand Lenslites*

*Foot Candles Delivered: 25 to 30*



# delivered the way you need it!

**CORNING ENGINEERED LIGHTINGWARE  
IS AVAILABLE FOR EVERY LIGHTING NEED**

Planning a home, showroom, office building, school, hotel or apartment? If so, "let there be light" . . . delivered the way you need it. Corning lighting experts will gladly assist you in selecting the lightingware that best meets your requirements. Corning products are scientifically made to provide proper diffusion or direction for both fluorescent and incandescent applications.

## FLUORESCENT LIGHTINGWARE

**ALBA-LITE** Lightingware provides high transmission, low reflection. It is a light opal glass available in rolled sheet form and may be bent to specification.

**MONA-LITE** Lightingware provides low transmission, high reflection. It is a dense opal glass available in rolled sheet form . . . supplied flat to specification.

**BALANCED LIGHTING:** Used separately or in combination, ALBA-LITE and MONA-LITE provide maximum flexibility in fixture design. Light diffusion is secured through glass composition rather than through surface treatment.

**FLUR-O-GUIDE LENS PANELS** in a wide range of lengths and widths provide light control with low panel brightness and permit maximum flexibility in fixture design.

## INCANDESCENT LIGHTINGWARE

**LENSLITES** made of PYREX Brand heat-resisting glass are available in many sizes, both round and square, for wide angle or concentrated light beam spread.

**MONAX** enclosing globes provide efficient, attractive, low-cost illumination on general diffuse lighting applications.

**CORNING I.E.S. TYPE** reflectors are ideally suited for table, bridge and floor lamps.

**RESIDENTIAL LIGHTINGWARE** by Corning includes bowls, globes and crystal lamp parts. They will enhance the appearance of any home.

For further information on MONA-LITE, Corning's newest fluorescent lightingware, write today for Bulletin LS-10

MONA-LITE

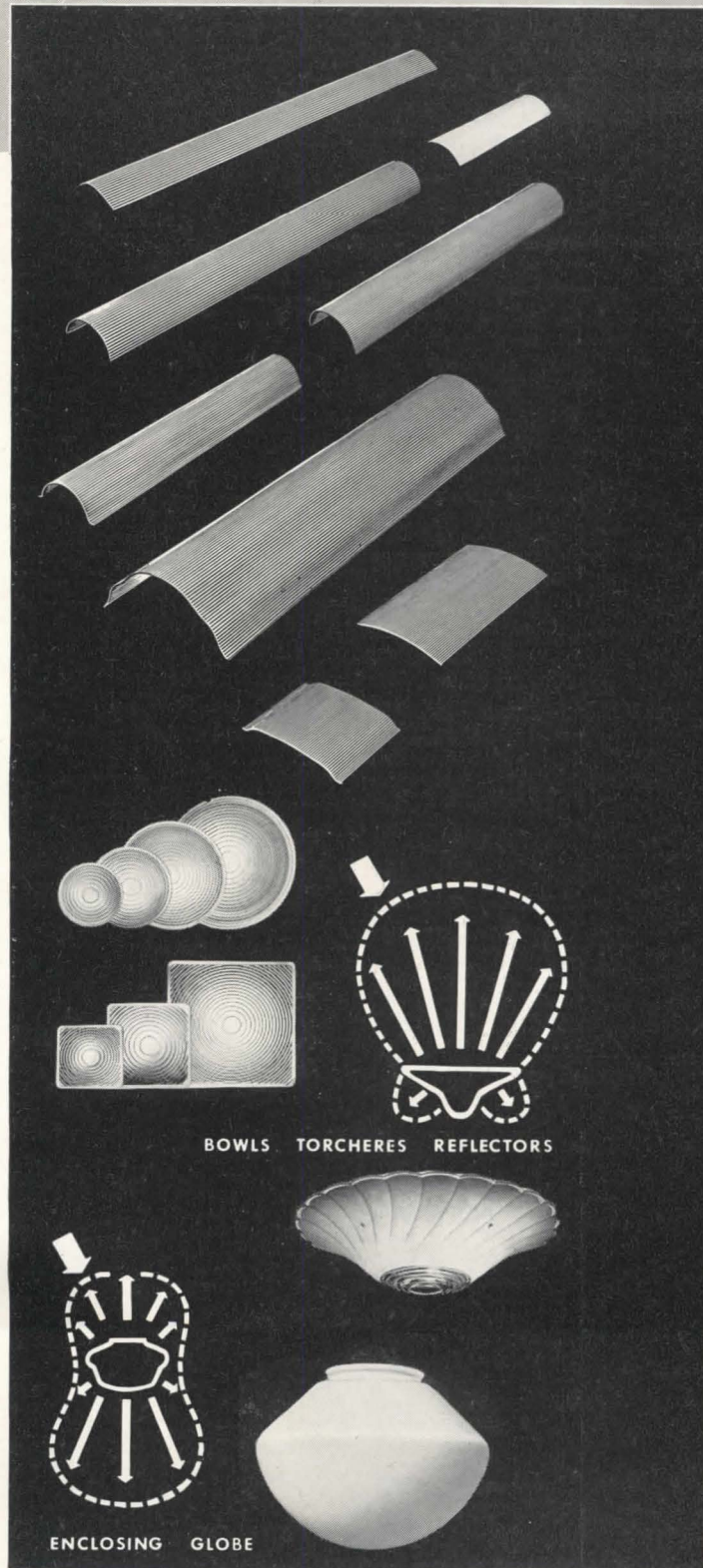

BOWLS TORCHERES REFLECTORS

ENCLOSING GLOBE



**CORNING GLASS WORKS • CORNING, N. Y.**  
SALES OFFICES: NEW YORK • CHICAGO • SAN FRANCISCO  
**LIGHTINGWARE**

TECHNICAL PRODUCTS DIVISION: LIGHTINGWARE • GAUGE GLASSES • GLASS PIPE • SIGNALWARE  
LABORATORY GLASSWARE • OPTICAL GLASS • GLASS COMPONENTS



## THE RECORD REPORTS

(Continued from page 7)

### Mortgage Credit Tighter

Washington continues to anticipate a progressively tightening mortgage credit market, a trend which has been apparent for some months. Lending institutions, it is noted, have been adopting increasingly conservative appraisal and lending policies.

FHA expects to do a fair amount of business during the year, hoping to insure a total of about 360,000 dwelling units. This outlook is heightened by the tendency of banks and other lenders to require insurance before making loans.

In this connection, remember too, that Congress extended insurance of veterans' housing mortgages for another nine months, until next March 31. Congress also authorized the insurance of short-term loans made by private institutions to finance the manufacture of housing. Currently procedures and regulations are being developed for putting this type of insurance into effect.

Continuance of repair loans for two years also got Congressional clearance and new reserves for the operation were established. And officials, incidentally, counted on an upturn in repair activity during the summer and early fall.

### Price Effects Felt

High costs continue to affect construction, even in the case of public works. FWA Chief Fleming reports that state highway departments have not awarded contracts at the rate anticipated because of bid prices exceeding estimates, a development which has resulted in the postwar highway program

(Continued on page 12)



With the work of clearing the site for the U.N. Headquarters already under way, further preliminary plans and sketches have been made public. Above, artist's bird's-eye view of the East River site in relation to central Manhattan; drawn by Chester Price. Below, possible treatment of the Plaza, south end of site; rendering by Hugh Ferriss

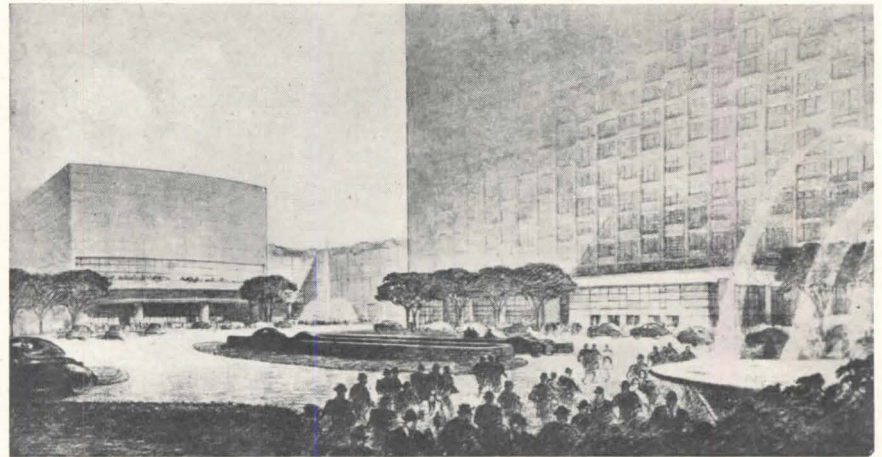

Official United Nations Photo

U.N. planners (l. to r.): Markelius, Sweden; Le Corbusier, France; Bodiansky, France; Liang, China; Harrison, U. S.; Niemeyer, Brazil; Soilleux, Australia; Bassov, U.S.S.R.; Abramowitz, U. S.; Weismann, Yugoslavia; Cormier, Canada; Antoniades, Greece; Nowicki, Poland



FOR PLASTER BASE



DOUBLE DUTY  
INSULITE GIVES



# Double

FOR THE MONEY!

Here are the facts: Double-duty INSULITE SEALED LOK-JOINT LATH performs *two* functions for inside walls—

(1st) *Plaster Base*

(2nd) *Insulation*

Two values for the price of one. A distinct advantage, quickly understood and appreciated by your clients. The reasons—You need a plaster base anyway—so why not have one that *insulates* at the same time . . . in addition it provides vapor control. Double for the money! This is smart, modern, progressive construction procedure—functional and economical. Specify double-duty Insulite Sealed Lok-Joint Lath.

Refer to Sweet's File,  
Architectural Section 10 a/9

INSULATES AS IT  
BUILDS AS IT

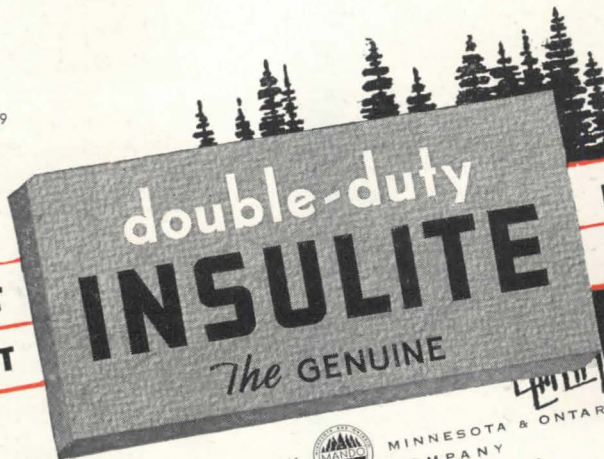

BUILDS  
INSULATES

"Insulite" is a registered  
trade mark, U.S. Pat. Off.

INSULITE DIVISION  
PAPER  
MINNEAPOLIS 2, MINNESOTA



MINNESOTA & ONTARIO  
PAPER  
COMPANY



# MICHAELS

## adjustable Astragals

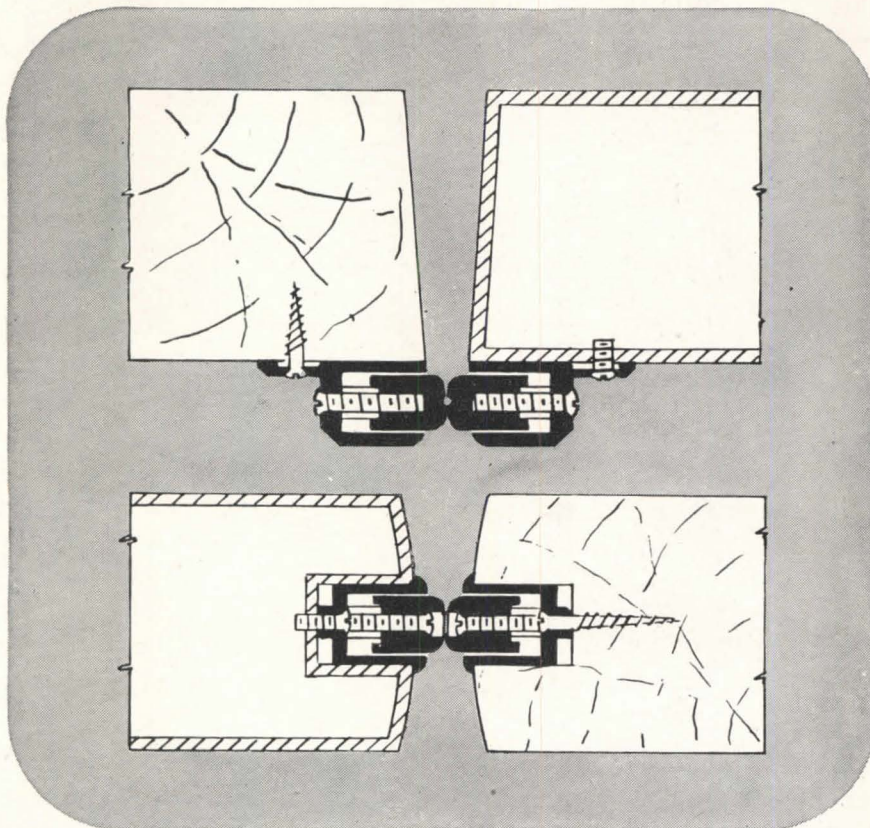

Made of extruded bronze, aluminum or nickel, Michaels Adjustable Astragals compensate for the expansion or contraction of doors. By keeping doors closed as tightly as possible, you eliminate drafts, air currents, and help to keep out dirt and dust. These astragals are simple, practical, rugged... easily installed and adjusted, and are available in several styles for any type of door. Type "A" shown in the illustration at the top, may be applied to either wood or hollow metal bevel doors. Or as a stop bead, or at the bottom of doors. Type "E" shown in the second illustration may be applied to bull-nose hollow metal or wood double doors, or at the bottom of doors. Folder containing complete details and specifications will be sent on request. We shall also be glad to send you information on any or all of the other products manufactured by Michaels.

### MICHAELS PRODUCTS

- Fixtures for Banks and Offices
- Welded Bronze Doors
- Elevator Doors
- Elevator Enclosures
- Check Desks (standing and wall)
- Lamp Standards
- Marquise
- Tablets and Signs
- Name Plates
- Railings (cast and wrought)
- Building Directories
- Bulletin Boards
- Stamped and Cast Radiator Grilles
- Grilles and Wickets
- Kick and Push Plates
- Push Bars
- Wrought Iron and Bronze Lighting Fixtures
- Wire Work
- Cast Thresholds
- Extruded Thresholds
- Extruded Casements and Store Front Sash
- Bronze and Iron Store Fronts
- Bronze Double Hung Windows
- Bronze Casement Windows

**THE MICHAELS ART BRONZE CO., Inc., 234 Scott St., Covington, Ky.**

*Member of the National Association of Ornamental Nonferrous Metals Manufacturers*

## THE RECORD REPORTS

*(Continued from page 10)*

moving at a rate slower than originally anticipated.

Testimony on price effects was received at hearings before the Congressional Joint Committee on the Economic Report. Some witnesses cited the "exorbitant level of construction costs" as a particularly unfavorable factor in the business outlook. Attention was called to cancellation of plant expansion programs because of high costs with heavy blame for high labor costs placed on "the reduced output of labor in the building trades."

The Bureau of Labor Statistics findings are summarized in the following sentence: "It is increasingly evident that the leveling off in (housing) activity is caused by rising construction costs." BLS pares the housing outlook for the year to about 725,000 starts and 765,000 completions.

Slowing down of construction and the continued rise in costs, the Department of Commerce adds, "may soon curb demand for building materials and make possible early replenishment of inventories."

### Trade Marks Act in Effect

Construction as well as other industries falls under the new Trade Marks Act, which became effective July 5. The Patent Office, which administers the Act, has brought out points of importance to concerns with trade-marked goods. Among these points is the fact that a mark registered after July 5, if uncontested for five years, definitely becomes the property of the registrant. Hence, concerns not sure of their markets — e.g., because they are new, because they may be litigated, etc. — must register quickly. Again, concerns disputing competitors' marks must watch to see whether their competitors register, in which case failure to protest could bring a loss through default.

Use of other people's brand names to sell completely different products depends on whether the Patent Office thinks the public will be confused. However, names of geographical places, personal names, etc., can be registered if they are associated with the product.

### Housing Bill Urged

In his caustic message on the rent control bill, it should be noted that President Truman called again for passage of the Wagner-Ellender-Taft general housing bill. He continues to emphasize six objectives for housing legislation: (1) aid to low-rent housing; (2) insurance for rental housing; (3) adequate farm housing program; (4) slum

*(Continued on page 14)*



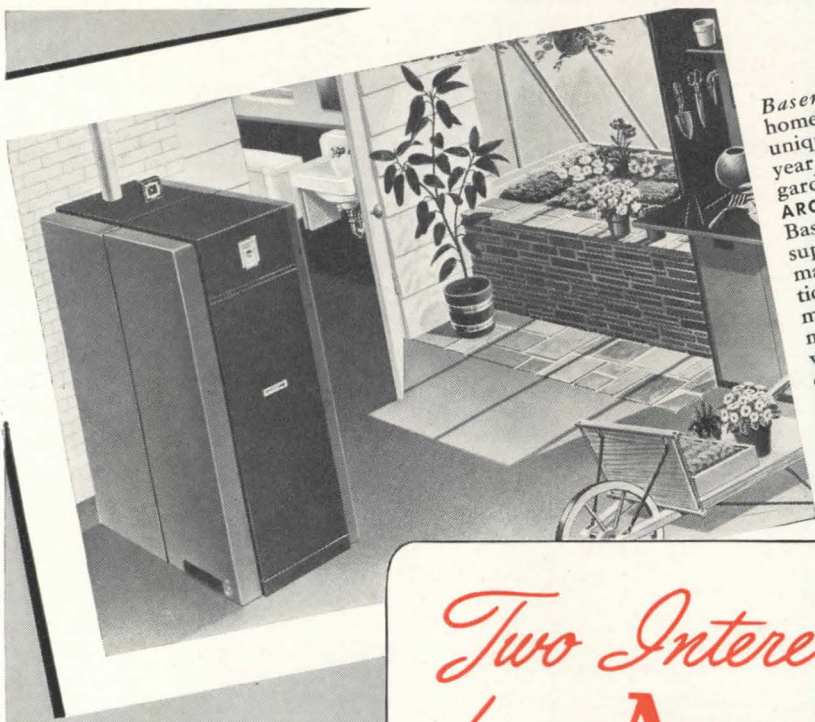

*Basement Conservatory.* For homes built on sloping lots, this unique downstairs room is a year 'round hobby corner for garden enthusiasts. The new **ARCOLINER** Oil Boiler (Wet Base), provides an abundant supply of clean, efficient, automatic heat. Correctly proportioned heating surfaces with multi-finned flues insure maximum heat absorption. Waterways that extend below fire chamber provide extra heating surface and help keep floor cool, thus making this model also ideal for first floor installation. For use with the Arcoflame or any other standard burner.

## Two Interesting Ideas from **AMERICAN-Standard**



*De luxe Bathroom.* Designed to satisfy the desire for really luxurious living. Fixtures are distinctively beautiful, efficiently engineered and durably constructed. The modern, roomy **NEO-ANGLE** Bath, occupying space only about four feet square, is of rigid cast iron with a heavy coating of gleaming, easy-to-clean, acid-resisting enamel. The graceful **NEOLYN** Lavatory, the quiet **MASTER ONE-PIECE** Closet and wall-hung **MADENTA** Dental Lavatory are of genuine vitreous china. All four fixtures are available in a wide range of harmonizing colors. Exposed metal is of non-tarnishing Chromard.



■ Both of these rooms owe much of their attractiveness and functional fitness to the American-Standard products they contain. Their modern styling and exceptional efficiency are two good reasons why more American homes have heating equipment and plumbing fixtures by American-Standard than by any other single manufacturer. Why not use these finer products in the homes you design, build or remodel? For complete information contact your Heating & Plumbing Contractor. **American Radiator & Standard Sanitary Corporation**, P. O. Box 1226, Pittsburgh 30, Pennsylvania.

*Serving the Nations' Health and Comfort*

**LOOK FOR THIS MARK OF MERIT**—It identifies the world's largest line of Heating and Plumbing Products for every use . . . including Boilers, Warm Air Furnaces, Winter Air Conditioners, Water Heaters, for all fuels—Radiators, Convectors, Enclosures—Gas and Oil Burners—Heating Accessories—Bathtubs, Water Closets, Lavatories, Kitchen Sinks, Laundry Trays, Brass Trim—and specialized products for Hospitals, Hotels, Schools, Ships, and Railroads.



**EXCLUSIVE-**

**THERE'S ONLY ONE  
GOLDEN GATE  
BRIDGE . . . AND**

**ONLY ONE-**

**AW SUPER-DIAMOND**

**FLOOR PLATE**

The need for better underfoot protection against costly slipping and falling accidents led to the creation of the exclusive AW Super-Diamond Floor Plate Pattern. Wet, dry or covered with oil, it *Grips Without A Slip*. It has no square corners to hold dirt so it's *Easy To Clean* with hose, brush or mop. AW Super-Diamond Floor Plate is *Easy To Match* and can be cut and installed overnight without interference to production. Follow the lead of front-rank Architects, Engineers and Product Designers and specify AW Super-Diamond Floor Plate for all of your needs.

**FREE** Write for a copy of our New 16-Page Booklet L-33. It's packed full of helpful information, maximum sizes, etc. Alan Wood Steel Company, Conshohocken, Pennsylvania.



**GRIP WITHOUT A SLIP!**

**EASY TO CLEAN!**

**EASY TO MATCH!**

**AW SUPER-DIAMOND**

**FLOOR PLATES THAT GRIP**



*A Product of* **ALAN WOOD STEEL COMPANY**

Other Products: Billets • Plates • Sheets • Carbon & Alloy



**THE RECORD REPORTS**

(Continued from page 12)

clearance aid to cities; (5) further home financing aids; (6) housing research.

In connection with slum clearance, the National Housing Agency has issued a study on "Slum Land Acquisition" which deals with payments made for land acquired for prewar public housing sites, analyzing more than 10,000 transactions. It includes tables giving city and regional breakdowns.



**ON THE CALENDAR**

*May 22-Sept. 15:* "Tomorrow's Buildings," exhibit of current work of members, Architectural League of New York, 115 E. 40th St., New York City.

*June 13-indefinite:* Exhibition of photographs, "Recent Discoveries in Chinese Architecture," Metropolitan Museum of Art, New York City.

*August 17-22:* Annual Meeting, American Society of Sanitary Engineering, Congress Hotel, Chicago.

*Sept. 1-4:* Fall Meeting, American Society of Mechanical Engineers, Hotel Utah, Salt Lake City, Utah.

*Sept. 11-12:* Businessmen's Conference on Urban Problems, Chamber of Commerce of the U. S., Washington, D. C.

*Oct. 14-19:* 1947 Westchester Better Homes Exposition, Westchester County Center, White Plains, N. Y.

*Oct. 18-24:* National Metal Exposition, International Amphitheatre, Chicago.

*Oct. 20-24:* Annual Meeting, American Society for Metals, Palmer House, Chicago.

*Oct. 20-24:* Annual Meeting, American Welding Society, Sherman Hotel, Chicago.

*Oct. 20-23:* Annual Fall Meeting, Iron and Steel Division and The Institute of Metals Division, American Institute of Mining and Metallurgical Engineers, Stevens Hotel, Chicago.

*Oct. 20-24:* Theater Engineering Conference and 62nd Semi-Annual Convention, Society of Motion Picture Engineers, Hotel Pennsylvania, New York.

*Oct. 22-25:* 1947 Convention, New York State Association of Architects, Hotel Commodore, New York City.

*Oct. 30-Nov. 1:* 15th Semi-Annual Meeting, American Society of Tool Engineers, Statler Hotel, Boston, Mass.

*Nov. 3-7:* 2nd International Lighting Exposition and Conference, Stevens Hotel, Chicago.

*Nov. 10-13:* 25th Annual Convention, The American Institute of Steel Construction, Inc., Roney Plaza Hotel, Miami Beach, Fla.

(Continued on page 16)



# EVERYTHING YOU WANT TO KNOW

## about Q-FLOOR wiring

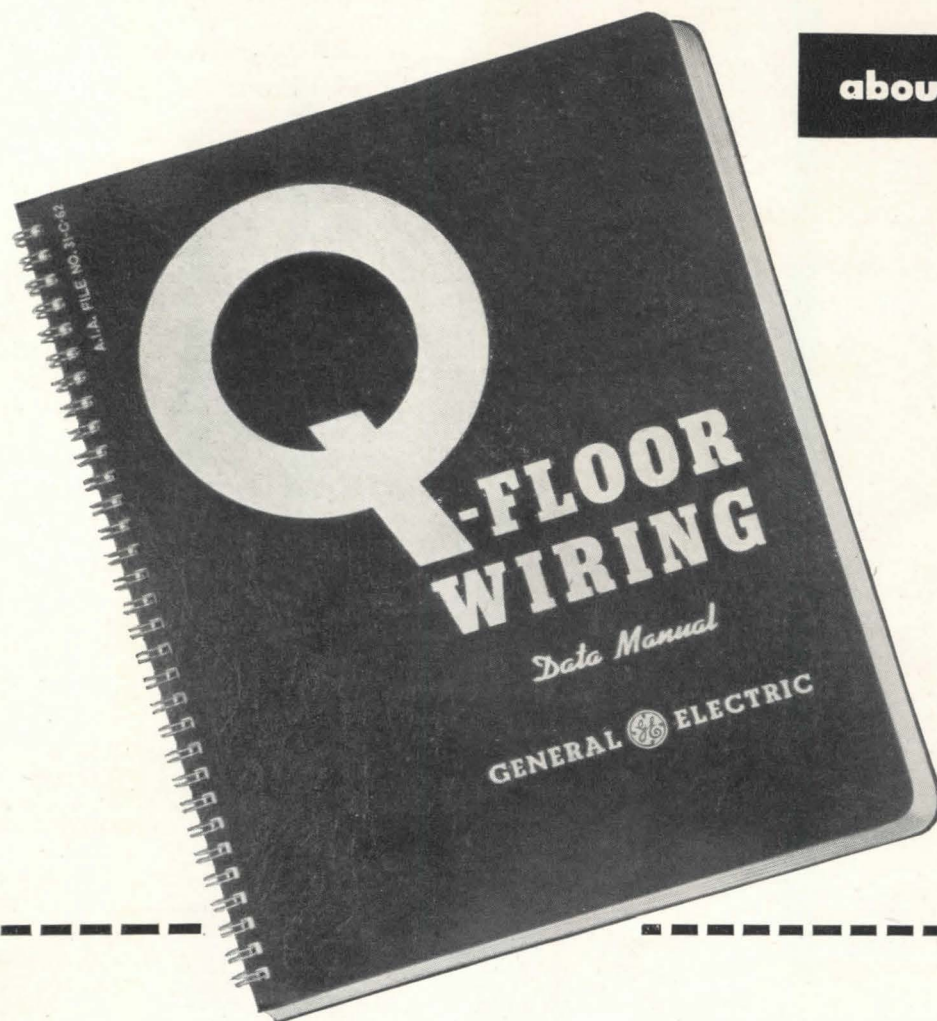

Packed into this brand-new Data Manual are answers to all your questions on planning for Q-Floor wiring. In its 92 pages you'll find enough specifications, descriptions, detail drawings, and installation photographs to give you the full story of this completely modern wiring system. The book has been designed throughout to acquaint you with the versatility of Q-Floors and Q-Floor wiring, and to make it easy for you to incorporate it in your plans. For your free copy of the *Q-Floor Wiring*, write on your letterhead to Section C63-85, Appliance and Merchandise Department, General Electric Company, Bridgeport 2, Connecticut.

### Contents:

**General Data**—Ten pages of explanation, telling what Q-Floor wiring is, and what it can do—and a question-and-answer section, giving you down-to-earth answers to your own questions.

**Product Listings**—Catalog descriptions and photographs of Q-Floor wiring components.

**Layout Design Data**—Diagrams and photographs explain how to get the utmost in electrical flexibility with Q-Floor wiring; how to fit it into your plans.

**Installation Data**—Details on construction requirements and on methods of installation.

**Dimensional Drawings**—Detail drawings of Q-Floor wiring components.

**Illustrations**—An excellent selection of installation photographs and pictures of new buildings utilizing Q-Floor wiring for flexible, economical electric systems.

### ON LARGE PROJECTS OR SMALL BUILDINGS

Q-Floors with Q-Floor wiring offers long-term economies and construction speed. Remember, too, that the General Electric line of conduit products is a full line for all construction needs.

GENERAL  ELECTRIC



## INDUSTRIAL BUILDINGS



## How to make a Good Plan an Efficient Plant...



When you specify a modern sound system—a Stromberg-Carlson *natural-voice* System—you make instant communication between every part of the plant possible. You help the executive in his office, the stenographer at her desk, the man at the bench, work better, more effortlessly, with work music. You supply the executive with a ready answer to any question on plant activity.

More, you specify a system that is *pre-engineered*. That fits into almost any architectural plan.

For information on the many models available, contact your local Stromberg-Carlson Sound Equipment distributor. He is listed in your phone book.

Or write for free booklets describing Stromberg-Carlson Sound Equipment for Industrial Buildings  Offices  Churches  Hotels  Schools  Hospitals . (Check information desired). Address: Stromberg-Carlson Co., Sound Equipment Division, Dept. A-8, 100 Carlson Road, Rochester 3, New York.

*The heart of any industrial sound system. Stromberg-Carlson Standard Sound System Model 750. Compact glacier gray cabinet houses AM-FM radio receiver, record player, all controls and amplifiers.*

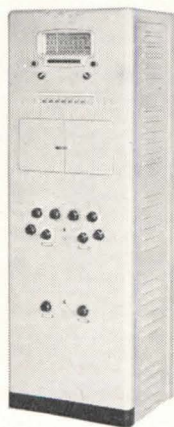



# STROMBERG-CARLSON

NATURAL-VOICE  SOUND SYSTEMS



## THE RECORD REPORTS

(Continued from page 14)

Dec. 2-5: Annual Meeting, American Society of Mechanical Engineers, Chalfonte-Haddon Hall, Atlantic City, N. J.

### CONSTRUCTION UP

New construction put in place during the first six months of 1947 increased 40.1 per cent over that in the same period of last year, according to the Construction Division, Department of Commerce.

For the first half of the year the total is estimated at \$5,356 million, compared with \$3,824 million in the first half of 1946. More than a seasonal gain was reported in June, when total new construction put in place amounted to \$1,062 million, an increase of 10.9 per cent over the May figure.

Private construction during the first six months this year totaled \$4,115 million, a gain of 31.9 per cent over the same period last year. Of this total, private residential construction (exclusive of farm) accounted for \$1,883 million, a gain of 63.2 per cent over last year. Public residential construction accounted for \$130 million, an increase of 75.6 per cent over 1946.

### LABOR-MANAGEMENT PROGRAM LAUNCHED

A comprehensive labor-management program to stimulate a high level of home building and commercial construction has been launched in Metropolitan New York as a means of forestalling any possible business recession. Sponsored by the New York Building Congress, in conjunction with the Building and Construction Trades Council, A. F. of L., and the Building Trades Employers Association, the campaign is designed to stabilize building costs, increase labor productivity and efficiency and to dispel the "wait and see" attitude of investors who are holding off construction work in anticipation of lower prices.

In announcing the program, Max H. Foley, president of the Building Congress and chairman of the sponsoring committee, said "that a new and unprecedented pledge of cooperation and higher productivity" had been given management by leaders of the building trades unions. Howard McSpedon, president of the Building and Construction Trades Council, A. F. of L., said the pledge of cooperation will be effective for all types of building—homes, commercial structures and institutional buildings.

The pledge reads:  
"Our trades stand willing and ready to join with our employers and all others

(Continued on page 18)



# Specify **ANEMOSTAT**

**DRAFTLESS AIR-DIFFUSION . . . . . for an  
air-conditioning job  
you'll be proud of!**

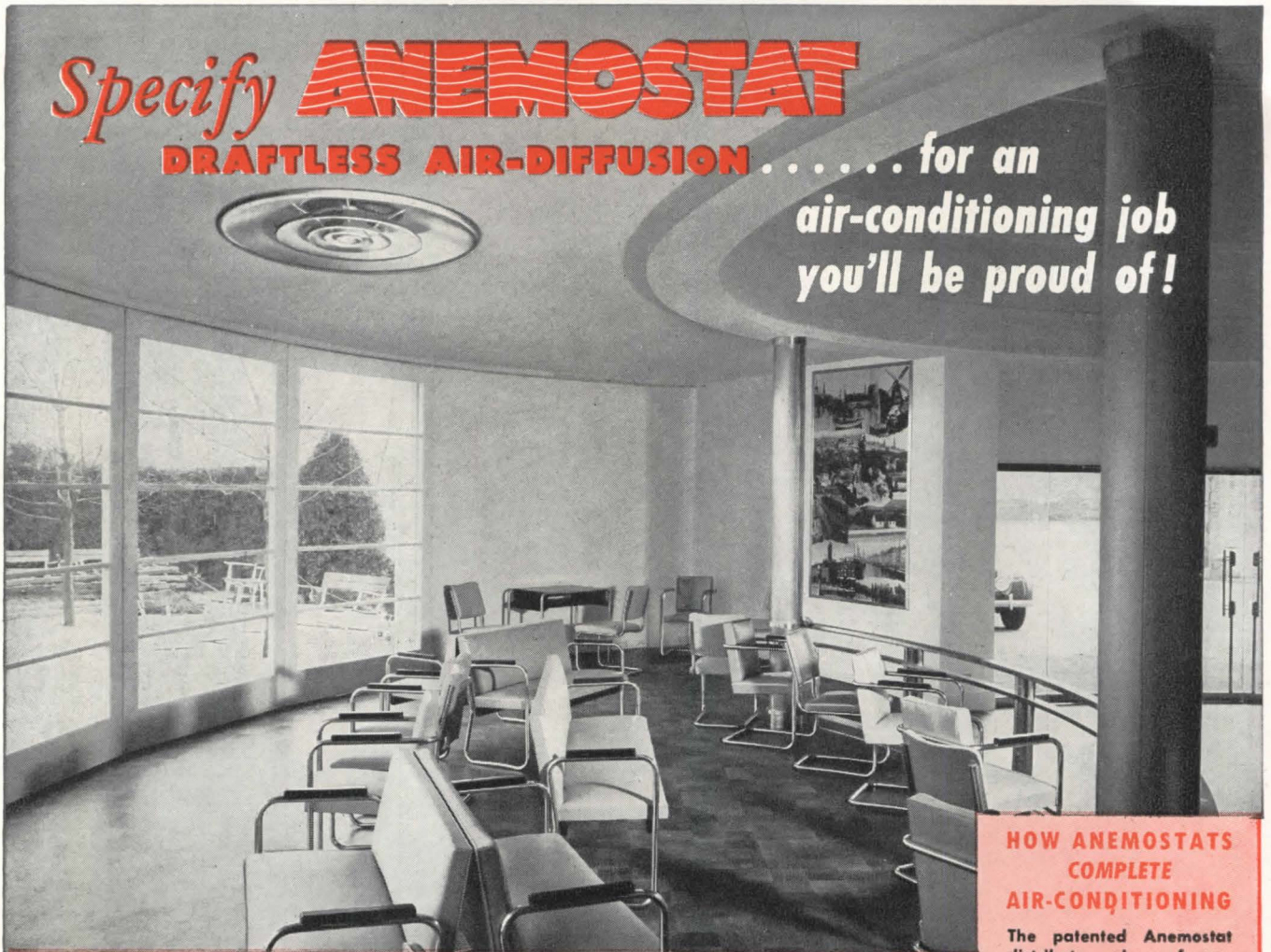

The best "advertising" for functional-minded architects, engineers and contractors is the excellence of their own craftsmanship . . . represented by modern structures that make living and working more pleasant. That is why they invariably regard an air-conditioning installation with Anemostat draftless air-diffusion as a job well done. A job that advertises them. A job to be proud of!

Anemostat takes the "raw materials" of air-conditioning and actually "processes" them into COMFORT. There are no draft-producing grilles or registers, for Anemostat air-diffusers distribute the conditioned air in pre-determined, controlled patterns. Result: there are

no drafts . . . no dead air pockets . . . room temperature and humidity are equalized throughout.

Because Anemostat wall or ceiling diffusers permit employment of stepped-up duct velocities and greater temperature differentials, duct sizes and duct outlets may be reduced — an important economy feature. Because Anemostats have no moving parts to wear out, maintenance cost is nil.

Thousands of Anemostat installations throughout the country — in virtually every industry — are putting new comfort into air-conditioning. So, remember to specify Anemostat draftless air-diffusion for an air-conditioning job you'll be proud of!

## HOW ANEMOSTATS COMPLETE AIR-CONDITIONING

The patented Anemostat distributes air — of any duct velocity — in all directions and in a multiplicity of planes. Simultaneously, counter-currents created by the device siphon into the Anemostat room-air equal to about 35 per cent of the volume of the supply air. This room-air is mixed with the supply-air within the diffuser before the air-mixture is discharged into the room. Furthermore, velocity of the incoming air is instantly reduced within the Anemostat by air-expansion.

In this way, the Anemostat noiselessly diffuses air of any duct velocity throughout the entire room . . . eliminates drafts . . . closely equalizes temperature and humidity . . . prevents air-stratification. There is no substitute for Anemostat air-diffusion!

Write for information.

# ANEMOSTAT

REG. U. S. PAT. OFF.

ANEMOSTAT CORPORATION OF AMERICA  
10 East 39th Street, New York 16, N. Y.

REPRESENTATIVES IN PRINCIPAL CITIES

"NO AIR-CONDITIONING SYSTEM IS BETTER THAN ITS AIR DISTRIBUTION"

AC-1117



Just as **WHITE** enhances  
a table setting...



Fine Terrazzo Floor of Atlas White Cement, Hotel Victor, Miami Beach, Florida

## Concrete craftsmen choose Atlas White Cement

A lustrous white tablecloth forms a background for silver to sparkle and candles to gleam. So, too, a matrix of Atlas White Cement sets off the color values of aggregates or pigments in Terrazzo, Stucco, Cement Paint and Architectural Concrete Slabs. Such a "setting" has the uniform clarity to complement the desired color overtones, whether in contrast or blend.

Atlas White complies with Federal and ASTM specifications for portland cement. It has the same advantages for concrete and is used in the same way. Cleaning is easy. Maintenance costs stay low.

For further information on the uses of Atlas White Cement, see SWEET'S Catalog, Sections 12B/7 and 13B/7, or write to Atlas White Bureau, Universal Atlas Cement Company (United States Steel Corporation Subsidiary), Chrysler Building, New York 17, New York.

AR-C-19

FOR BEAUTY AND UTILITY  
**ATLAS WHITE CEMENT**  
FOR TERRAZZO, PAINT, SLABS, STUCCO



"THEATRE GUILD ON THE AIR"—Sponsored by U. S. Steel Subsidiaries  
Sunday Evenings—September to June—ABC Network

## THE RECORD REPORTS

(Continued from page 16)

in our industry to go ahead with all jobs and help bring about a reduction in building costs by pledging again as our agreements now provide for until 1950:

"1. No limitation on a man's output because we have always agreed a fair day's work for a fair day's wage;

"2. No strikes or stoppages for agreement or jurisdictional disputes because all our agreements provide for mediation or arbitration of such disputes;

"3. We will man all jobs with sufficient labor and we expect cooperation not only of our employer, but also the awarding authorities in scheduling their jobs so that we can plan with some degree of certainty;

"4. We again emphasize the right of the employer to hire or discharge any man he sees fit and, as our present agreements and laws provide, we will discipline any member who violates our agreement in this respect."

In a strong warning to suppliers and manufacturers of building materials and equipment against rising costs, Mr. Foley urged their full cooperation in the construction campaign, and expressed the hope that "there will be a determined effort on the part of the suppliers of materials and equipment to stabilize prices while there are still buyers." He asserted that he saw no possibility of a drastic reduction in building costs in the near future, but emphasized that at the present time it is more important to stabilize costs. "It is to be hoped," he said, "that we can stabilize at a somewhat lower level than the present, but the important thing is to reach a level at which a builder can give an owner a cost estimate on a building operation with a reasonable expectation that it will not be exceeded."

### BUILDING NOTES

#### Army Medical Center

What is planned to be the greatest medical research center in the world will be built at Forest Glen, Md., by the Corps of Engineers for the Office of the Surgeon General, the War Department has announced. In keeping with technological advances in all fields, based on experiences in the last war, the center will be equipped to anticipate and meet the medical problems of the future as well as to cope with those of the present. The initial cost is estimated at approximately \$40 million.

Officially designated as the Army Medical Research and Graduate Teaching Center, the project will consist of a 1000-bed general medical and surgical hospital, capable of expansion to 1500 beds; the Army Institute of Pathology

(Continued on page 126)



# For All-weather Ventilation

## LOW-COST FENCRAFT PROJECTED WINDOWS

Designed for: SCHOOLS • HOSPITALS • OFFICES AND PUBLIC BUILDINGS

### OPEN-OUT VENT—

Forms canopy over opening. Sheds rain and snow away from the opening.

### SILL VENT—

1. Deflects incoming air upward—prevents drafts.
2. Sheds rain to outside.
3. Prevents leaning out windows—guards against falls.

Vents are easy to reach—simple to open, close and lock. Ventilators stay in selected open position—close to a weather-tight fit. Both sides can safely be washed from inside the room. Screens attached or removed from inside.

The trim lines of Fencraft Projected Windows enhance both inside and outside appearance—match architectural trends to the horizontal. Extra daylight, firesafety and low maintenance . . . all are benefits that make them ideal for many types of buildings.

**STANDARDIZED FOR ECONOMY.** The Fencraft family of windows—Projected, Combination and Casement—has been standardized in sizes that conform with current modular construction practice. Standardization reduces first cost and saves installation time and money. Fencraft

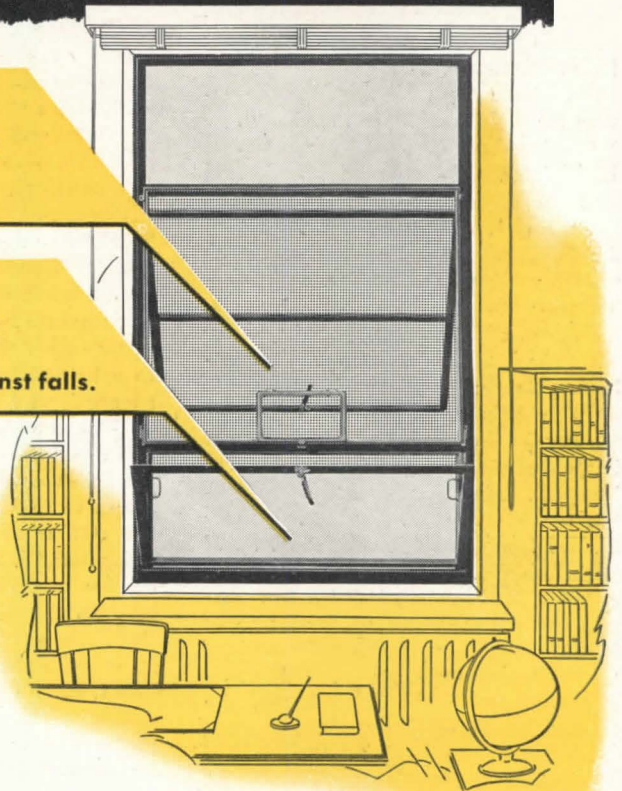

Windows are built by craftsmen of America's oldest and largest steel window manufacturer. For details, see Sweet's Architectural File (Section 16a-9) or mail the coupon.

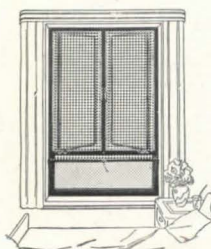

### FENCRAFT COMBINATION WINDOW

—generous fresh-air ventilation. Swing leaves deflect breezes into the room. In-tilting sill vent protects against drafts. Both sides safely washed from inside. Ideal for hospitals and office buildings.

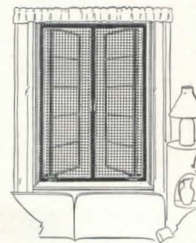

### FENCRAFT CASEMENT WINDOW

—safe washing—from inside. Easy to operate. Uniform screens, protected from outside dirt. "Homey" appearance makes them ideal for clubs, large homes, dormitories, and nurses' homes.

# Fenestra

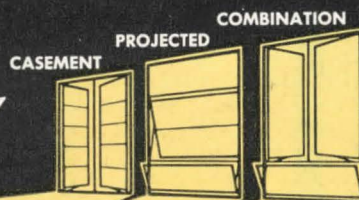

FENCRAFT INTERMEDIATE STEEL WINDOWS

Detroit Steel Products Company  
Dept. AR-8,  
2252 East Grand Blvd.,  
Detroit 11, Michigan

Please send me data on types and sizes of the new Fenestra family of Fenestra Windows:

Name \_\_\_\_\_

Company \_\_\_\_\_

Address \_\_\_\_\_



## LETTERS FROM RECORD READERS

### RECORD:

We have found lately published books, publicity and propaganda that have been quite misleading in regard to the planning and building of Rockefeller Center. Thought it advisable not to fight publicity, but to establish the facts from the records in order to avoid continuous discussion which comes up with our fellow colleagues.

Here is a complete listing from the records for each building in the Center.

On October 22, 1929, Reinhard and Hofmeister were selected as General Architects.

On July 1, 1930, a contract was signed for the services of: Reinhard and Hofmeister; Corbett, Harrison and MacMurray; Hood, Godley and Fouilhoux. This was the first contract signed for the group and in same we find the following clause:

"The primary inducement to the Owners for the making of this agreement is the desire to secure the personal services of L. Andrew Reinhard, Henry Hofmeister, Harvey W. Corbett, Wallace K. Harrison and Raymond Hood. . . ."

On June 1, 1935, the July 1, 1930, contract was cancelled and a new contract was signed due to the death of Raymond Hood and the retirement of Godley some time before. This takes you through to the beginning of the International Building — 1936.

The RCA Building, RKO Building, Music Hall, Center Theater, French and British Buildings, and International Building, had the Architects of Record listed as follows: Reinhard and Hofmeister; Corbett, Harrison and MacMurray; Hood and Fouilhoux.

The Time and Life Building Architects of Record: Reinhard and Hofmeister; Corbett and MacMurray; Wallace K. Harrison; J. Andrew Fouilhoux.

The Associated Press Building, same as the Time and Life Building listing.

The Eastern Air Lines and Center Garage Architects of Record: Reinhard and Hofmeister; Wallace K. Harrison; J. Andrew Fouilhoux.

The U. S. Rubber Building, the same listing as above.

— REINHARD & HOFMEISTER  
by L. Andrew Reinhard

### RECORD:

I read with absorbing interest the text of Carl Koch's address to the A.I.A. convention. You may be sure this is a subject which has occupied the thoughts of many young architects, and I believe Mr. Koch has been the spokesman for more people than he realized.

A professional man, to be worthy of the title, should put service above per-

sonal gain. Likewise, a professional organization should be the vehicle through which its members and the entire profession may find inspiration and guidance toward that common aim. However, it seems that the Institute's chief concern with professionalism is in the maintenance of an arbitrary code of ethics. Strict compliance will supposedly insure an architect honor among his associates and have the magic effect of raising him above the level of the ordinary business man. After thus assuring himself of his standing, he is entitled, in fact required, to charge a stipulated minimum fee for "professional services." Whether or not the value of his service justifies the fee seems unimportant.

As a draftsman I resisted attempts by trade unions to obtain my membership. Their selfish aims seemed contradictory to worth-while standards of service. As an architect I have declined invitations to join the A.I.A. for essentially the same reason. Of course, the stock rejoinder is always "get in and push" or words to that effect. That was exactly the answer that I received from the union official. Obviously, the idea of a change in policy of the trade-union movement was, to say the least, impractical. To a lesser degree, I have the same feeling about the Institute.

Mr. Koch has spoken and the profession has listened respectfully. His words have meaning because they are backed by honest buildings and grateful clients. However, a less experienced or less successful architect must devote his energies to building his reputation and sustaining himself. No time for fighting windmills!

— NORRIS M. GADDIS  
Assistant Professor of Architecture,  
Iowa State College

### RECORD:

Our thanks to ARCHITECTURAL RECORD for publishing the paper which Carl Koch delivered at the A.I.A. convention in April. Those of us who did not attend had gotten a somewhat distorted report of the paper. I am fully in accord with your editorial in the June issue and feel that Koch, in a most courteous and constructive manner, has presented the shortcomings of the Institute. The fence-riding of the Institute is not limited to Boston or the national office in Washington, but is found in virtually all chapters with which I have had contact and is most prevalent here in Texas.

Our friend, Chester Nagel, in the May issue of the *Journal of the American Institute of Architects* presented a voice from within the Institute in his letter, "What's Wrong with the Institute?" We

are fully in accord with the thoughts and principles expressed by Koch and Nagel and hope the RECORD will help carry the principles of good architecture to the very heart of the profession.

— CHARLES GRANGER, A.I.A.

### RECORD:

The Old Guard, still articulate on their favorite nostrums, have apparently arrived at that place where there is nothing more to learn. The Learned, timid on the question, "What type of man do you employ to teach the students?" and inarticulate on such questions as "To what type of office does the graduate go?" and "What has been the advancement in the method of architectural education in the last 20 years — if any?" have arrived at that same Isle of the Blessed where there is nothing to teach. . . .

Most architectural schools either consciously or unconsciously use an offshoot of the Beaux-Arts Grand Plan method in that they ask an embryo architect to design (with all the verb implies) and present in five to six weeks a project, the scope of which in actual practice requires the undivided efforts of several experienced men and the facilities of a smoothly working architectural office. The result for the student, contrary to the claimed trend toward analytical thoroughness, is haphazard reasoning and cosmetic clichés all wrapped up in a facile presentation. I would much rather have a graduate who has designed well a classroom than sloughed through a half-baked solution of an intricate school building project, who knows the classroom problems of the teacher and the child, who has studied the visual conditions, acoustics, ventilation, equipment, and maintenance problems of a classroom.

The Educators' idea is to start the creative fire in the student by simple problems in elementary design, kindle it in intermediate, pour the coal on in advanced, and really fan the blaze in the thesis. The problem scope is too great and the student doesn't learn to think basically, but most of them learn to "draw." There is a partially successful effort to tie in construction and allied courses with the design. Architectural schools might well take a hint from the progressive elementary and high school teaching methods of "learning-doing."

To the Old Guard I would say: The more progressive and thinking student wants to start in the small progressive office. Why? He is closer to the brains and heart of each problem, and, ironically, the smaller office now seems to have more time and money to devote to his education, which answers the other question — this is probably the biggest advancement in architectural education in the last 20 years.

— DON HATCH, Architect



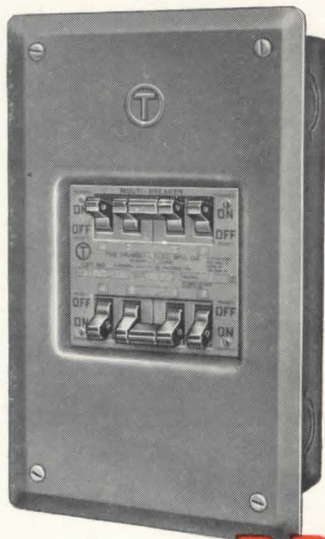

TRUMBULL **T** ELECTRIC  
**MULTI-BREAKERS**

**PROTECT**  
**BUTLER  BUILT**  
**HOMES**



Many factory-built homes are on the drawing boards but here's one that is being delivered. The Butler Mfg. Co. profits this home with patented key-lock aluminum panels so that it can be erected in about two weeks . . . and expanded, as desired, with little trouble.

Such a modern home should have modern conveniences . . . so along with other features of safety and comfort, the builders have selected Trumbull Multi-Breakers for simplified protection of electrical circuits, thereby eliminating the old fashioned bother of replacing blown fuses.

For further information contact your local Trumbull Distributor.

**THE TRUMBULL ELECTRIC MANUFACTURING COMPANY**  
**PLAINVILLE, CONNECTICUT**

**Other Factories at Norwood, Ohio, Seattle, San Francisco, North Hollywood**



# AN OFFICIAL ANNOUNCEMENT of importance to all Architects

# Fabron

REG. U. S. PAT. OFF

—THE fabric-plastic-lacquer wall finish—

## PREVENTS FIRE SPREAD

Tests made by the Underwriters' Laboratories, Inc., sponsored by the National Board of Fire Underwriters, proves that—

1. Fire spread of FABRON over unpainted plaster walls is **negative**.
2. FABRON is **non-toxic**.
3. Smoke development is **negligible**.

As a result of these tests, FABRON is now listed by the Underwriters' Laboratories, Inc., and their label of approval is affixed to each FABRON roll.



IN ADDITION TO ITS VALUE AS A FIRE SPREAD PREVENTIVE, FABRON OFFERS MANY OTHER ADVANTAGES NOT FOUND—COMBINED—IN ANY OTHER WALL TREATMENT.

Contrast these FABRON features against other wall finishes:

- it decorates walls permanently.
- it protects and reinforces sub-surface materials.
- it binds and strengthens weakened or patched plaster and prevents plaster cracks.
- it is easy to apply — easy to clean — sunfast.
- it can be applied to any properly prepared smooth surface.
- it affords years of uninterrupted service and continues to serve as a wall-protective agent for many years after it has outlived its original decorative function.



All these features combined make FABRON the most economical and desirable finish for interior walls and ceilings of buildings of all types, from the angle of the architect and his client alike.

Specifications forms will be sent on request.

## FREDERIC BLANK & COMPANY, INC.

Established 1913

230 PARK AVENUE

NEW YORK 17, N. Y.



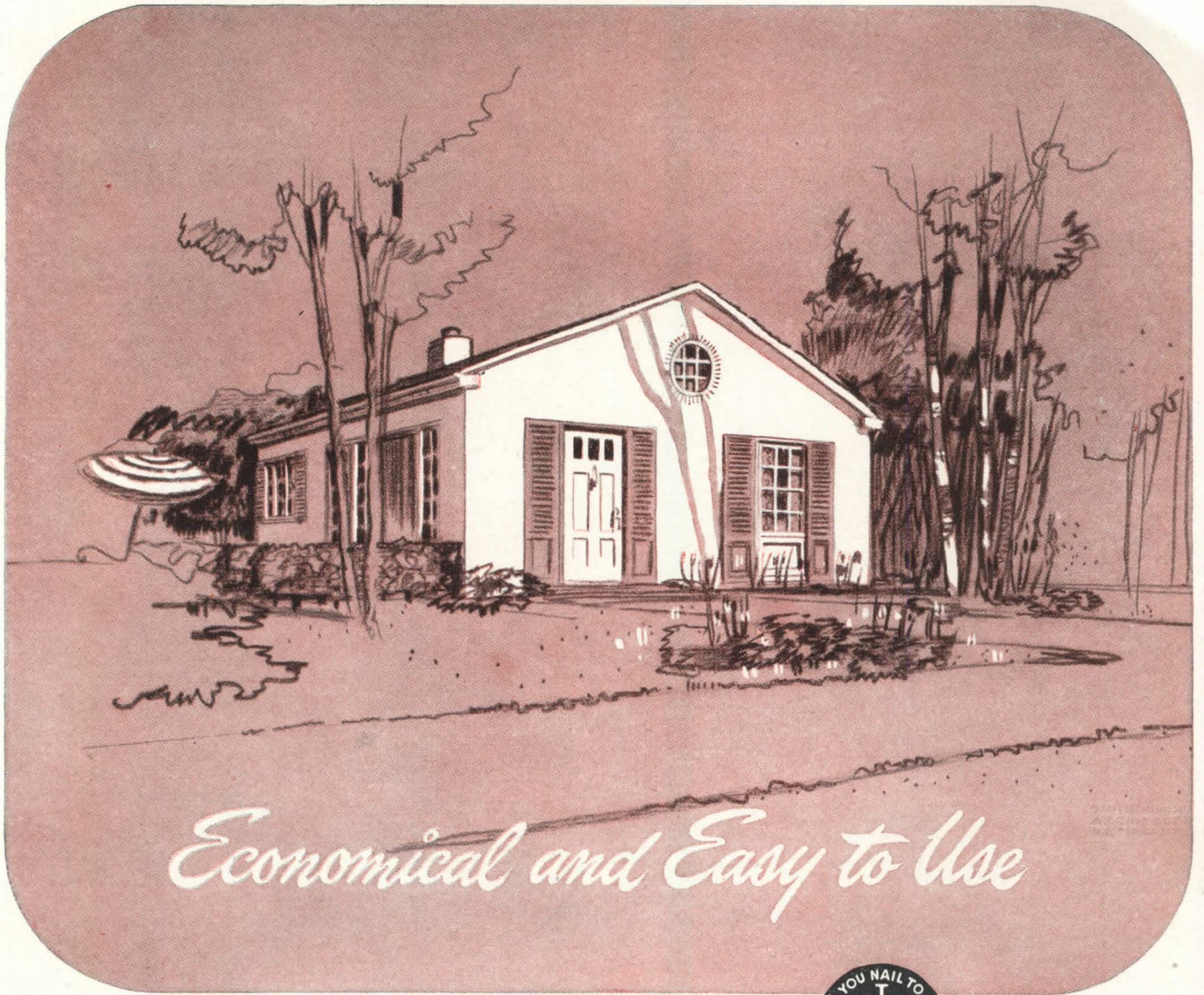

*Economical and Easy to Use*

Stran-Steel framing is a building product of Great Lakes Steel Corporation



When they use Stran-Steel packaged framing for the first time, architects and builders alike are surprised that steel can be so easy to work with. Consisting of only a few basic types of framing members and fittings, the Stran-Steel system is simple and efficient. Yet it allows full flexibility of design. Practically any type of framing connection is possible, and any standard collaterals can be used.

Two unique construction features make Stran-Steel packaged framing ideally suited for light-load buildings. One is the fact that members can be quickly assembled with self-threading screws. The other is the patented *nailing groove*, an integral part of every Stran-Steel stud and joist. By means of this groove, collaterals can be nailed directly to the frame, just as easily as to wood.

By virtue of its efficiency, Stran-Steel is *economical*. To prospective owners it represents a sound invest-

ment in long building life, simplified maintenance and added fire protection.



**GREAT LAKES STEEL CORPORATION**

Stran-Steel Division • Dept. 36 • Penobscot Building • Detroit 26, Michigan  
UNIT OF NATIONAL STEEL CORPORATION



*Angle #4*

Some New Angles  
on  
INDUSTRIAL  
and  
COMMERCIAL  
HEATING

74°

70°

70°

65°

**WORKING-LEVEL RECIRCULATION**

Actual tests with balloon-suspended thermometers in a building with 200,000 square feet of roof showed temperature differential between roof and working area to be only 9 degrees with Dravo Heaters. This is a big fuel-saving advantage when compared with other methods in which roof area temperatures are often 35 degrees higher than those at the working level.

The Dravo Counterflo Heater, oil or gas-fired, offers today's highest possible efficiency for open space heating. It recirculates warm air in the working level, thus minimizing the tendency of the heated air to rise and cause excessive heat losses through the roof. Under the Dravo method warm air is discharged above the heads of the workers and cool air is taken off the floor. This provides a thermostatically controlled comfort zone in the working level with no annoyance to workers.

In addition to saving fuel through low roof heat loss, the Dravo Heater is extremely economical in

these respects . . . **Sustained efficiency of 80 to 85%**—constantly getting more Btus from each gallon of oil or cubic foot of gas burned. — **Lower initial cost compared with indirect heating systems.** — **Ease of installation . . . it is necessary only to provide power line, fuel line and stack.** — **No stand-by heat or specialized attendant is necessary. Heater operates only when thermostat dictates your requirements.**

Dravo Heaters are available in capacities ranging from 400,000 to 2,000,000 BTUs per hour output. The money-saving angles for Industrial and Commercial Heating with DRAVO COUNTERFLO DIRECT FIRED HEATERS are more fully described in Bulletin EU 516. Write Heating Section, DRAVO CORPORATION, 300 Penn Ave., Pittsburgh 22, Pa.

Dravo Counterflo Direct Fired Heaters are products of the Machinery Division.

**DRAVO CORPORATION**

PITTSBURGH · PHILADELPHIA · CLEVELAND · NEW YORK  
DETROIT · WASHINGTON · ATLANTA · WILMINGTON

**AVAILABLE  
IMMEDIATELY**







## WOULD YOUR CLIENT PAY 3¢ A DAY FOR QUIET?

Have you ever told a client that for 3¢ a day he can free himself from the jumbled din of ringing telephones, clattering typewriters, and distracting voices?

It's true, and it's worth talking about. Only 3¢ a day per person, figured over just a few years, is all it costs a business to protect itself from noise with a ceiling of Armstrong's Cushiontone. And that cost is repaid many times over in increased efficiency alone.

Cushiontone is a permanent

cure for noise. More than three-quarters of all the sound that strikes the surface of Cushiontone is absorbed in the 484 deep fibrous holes of each 12" square of this material. Not even repainting will affect this unusually high acoustical efficiency.

Armstrong's Cushiontone is a good reflector of light and is easy to maintain. It provides extra insulation. Your local Armstrong contractor will be glad to prove

to you with a free estimate the economy of a Cushiontone ceiling.

**WRITE FOR FREE BOOKLET**, "How to Exterminate Office Noise Demons," and technical data. Armstrong Cork Company, Acoustical Dept., 2408 Stevens Street, Lancaster, Pa.

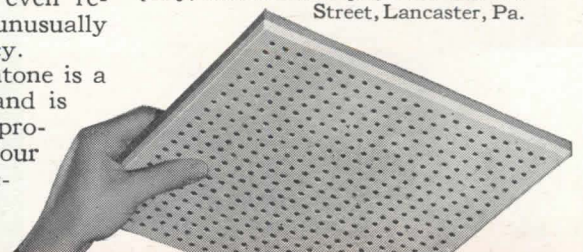

CUSHIONTONE IS A REGISTERED TRADE-MARK

# ARMSTRONG'S CUSHIONTONE

Armstrong Cork Company (A) Lancaster, Pennsylvania



**A COMPANY IS KNOWN *by the customers it keeps!***



512 FIFTH AVENUE, NEW YORK  
82 RUE #HAUTEVILLE, PARIS

GENERAL OFFICES  
205 SOUTH STATE STREET  
CHICAGO

**O'CONNOR & GOLDBERG**  
SHOES AND HOSIERY

In the operation of our 14 O-G stores of Chicago we have found that revolving doors not only enhance the beauty of the store but are also highly practical in both hot and cold weather. We reached this conclusion after many years of experience.

Very truly yours,

*Samuel O'Connell*  
O'CONNOR & GOLDBERG

The classic lines of this revolving door installation in the O'Connor & Goldberg store, Evanston, Illinois, eliminates traffic problems and lends inviting beauty to the building exterior.



The latest O'Connor & Goldberg revolving door as it looks from inside. Of all-glass design, it is floor supported and has minimum 2" cornice, traffic control and special ceiling lights. Maher & McGrew, architects.

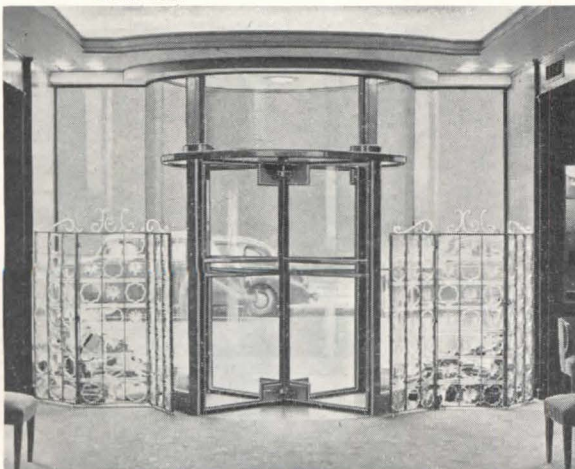

**29 YEARS OF PERFECT SERVICE**

O'Connor & Goldberg, nationally known retailer of fine shoes, hosiery and accessories, installed its first revolving door in 1918. So well pleased were the store's executives with the additional space provided, the greater store comfort, increased operating economy, and reduced noise, dirt and drafts, that they decided to use revolving doors in all O'Connor & Goldberg stores . . . new and old alike. New doors were added in each of the years 1921, 1923, 1926, 1928 and 1929. Four were installed in 1941, one in 1942. The latest, shown at left, has been in operation in the Evanston store since 1946.

The experience of O'Connor & Goldberg is being duplicated in the nation's busiest and finest buildings everywhere. If yours is an entrance problem, you'll find the advantages of revolving doors by International unequalled by any other make or type of entrance. Complete details for the asking.

**REVOLVING**  
**INTERNATIONAL VAN KANNEL**  
**DOORS**  
1530 EDGAR STREET EVANSVILLE 7, IND.

**International Van Kannel Revolving Doors . . . Used in America's Finest Buildings**



# CONSTRUCTION COST INDEXES — Labor and Materials

United States average 1926—1929=100

Compiled by Clyde Shute, manager, Statistical and Research Division, F. W. Dodge Corporation, from data collected by E. H. Boeckh & Associates, Inc.

## NEW YORK

## ATLANTA

Period	Residential		Apts., Hotels, Office Bldgs. Brick and Concr.	Commercial and Factory Buildings		Residential		Apts., Hotels, Office Bldgs. Brick and Concr.	Commercial and Factory Buildings	
	Brick	Frame		Brick and Steel	Brick and Steel	Brick	Frame		Brick and Steel	Brick and Steel
1920	136.1	136.9	123.3	123.6	122.6	122.8	122.9	108.6	109.8	105.7
1925	121.5	122.8	111.4	113.3	110.3	86.4	85.0	88.6	92.5	83.4
1930	127.0	126.7	124.1	128.0	123.6	82.1	80.9	84.5	86.1	83.6
1935	93.8	91.3	104.7	108.5	105.5	72.3	67.9	84.0	87.1	85.1
1939	123.5	122.4	130.7	133.4	130.1	86.3	83.1	95.1	97.4	94.7
1940	126.3	125.1	132.2	135.1	131.4	91.0	89.0	96.9	98.5	97.5
1941	134.5	135.1	135.1	137.2	134.5	97.5	96.1	99.9	101.4	100.8
1942	139.1	140.7	137.9	139.3	137.1	102.8	102.5	104.4	104.9	105.1
1943	142.5	144.5	140.2	141.7	139.0	109.2	109.8	108.5	108.1	108.7
1944	153.1	154.3	149.6	152.6	149.6	123.2	124.5	117.3	117.2	118.2
1945	160.5	161.7	156.3	158.0	155.4	132.1	133.9	123.2	122.8	123.3
1946	181.8	182.4	177.2	179.0	174.8	148.1	149.2	136.8	136.4	135.1
Feb. 1947	204.7	208.9	194.7	193.5	191.1	165.8	166.8	148.8	149.9	148.8
Mar. 1947	211.2	217.2	196.2	194.4	192.9	178.7	182.9	153.4	152.0	153.1
Apr. 1947	217.6	220.8	204.7	205.9	202.4	179.2	183.3	154.4	153.5	153.5
May 1947	219.1	221.6	205.6	206.8	203.4	180.2	183.9	155.1	154.1	154.2
	% increase over 1939					% increase over 1939				
May 1947	77.4	81.0	57.3	54.9	56.2	108.9	121.2	63.1	58.3	62.8

## ST. LOUIS

## SAN FRANCISCO

1920	118.1	121.1	112.1	110.7	113.1	108.8	107.5	115.2	115.1	122.1
1925	118.6	118.4	116.3	118.1	114.4	91.0	86.5	99.5	102.1	98.0
1930	108.9	108.3	112.4	115.3	111.3	90.8	86.8	100.4	104.9	100.4
1935	95.1	90.1	104.1	108.3	105.4	89.5	84.5	96.4	103.7	99.7
1939	110.2	107.0	118.7	119.8	119.0	105.6	99.3	117.4	121.9	116.5
1940	112.6	110.1	119.3	120.3	119.4	106.4	101.2	116.3	120.1	115.5
1941	118.8	118.0	121.2	121.7	122.2	116.3	112.9	120.5	123.4	124.3
1942	124.5	123.3	126.9	128.6	126.9	123.6	120.1	127.5	129.3	130.8
1943	128.2	126.4	131.2	133.3	130.3	131.3	127.7	133.2	136.6	136.3
1944	138.4	138.4	135.7	136.7	136.6	139.4	137.1	139.4	142.0	142.4
1945	152.8	152.3	146.2	148.5	145.6	146.2	144.3	144.5	146.8	147.9
1946	167.1	167.4	159.1	161.1	158.1	159.7	157.5	157.9	159.3	160.0
Feb. 1947	187.6	187.0	173.9	175.2	172.8	177.0	173.9	172.4	174.6	176.1
Mar. 1947	196.9	198.9	175.8	176.4	175.3	185.6	184.9	174.2	175.7	178.4
Apr. 1947	199.1	200.3	178.0	179.0	176.9	188.6	187.0	177.8	180.4	180.7
May 1947	199.3	200.5	178.3	179.2	177.1	188.8	187.2	178.1	180.6	180.9
	% increase over 1939					% increase over 1939				
May 1947	80.8	87.5	50.1	49.6	48.8	78.8	88.5	51.7	48.2	55.2

The index numbers shown are for combined material and labor costs. The indexes for each separate type of construction relate to the United States average for 1926-29 for that particular type — considered 100.

Cost comparisons, as percentage differences for any particular type of construction, are possible between localities, or periods of time within the same city, by dividing the difference between the two index numbers by one of them; i.e.:

index for city A = 110  
index for city B = 95

(both indexes must be for the same type of construction).

Then: costs in A are approximately 16 per cent higher than in B.

$$\frac{110-95}{95} = 0.158$$

Conversely: costs in B are approximately 14 per cent lower than in A.

$$\frac{110-95}{110} = 0.136$$

Cost comparisons cannot be made between different types of construction because the index numbers for each type relate to a different U. S. average for 1926-29.

Material prices and wage rates used in the current indexes make no allowance for payments in excess of published legal prices, thus, indexes reflect minimum costs and not necessarily actual costs.

These index numbers will appear whenever changes are significant.



## REQUIRED READING

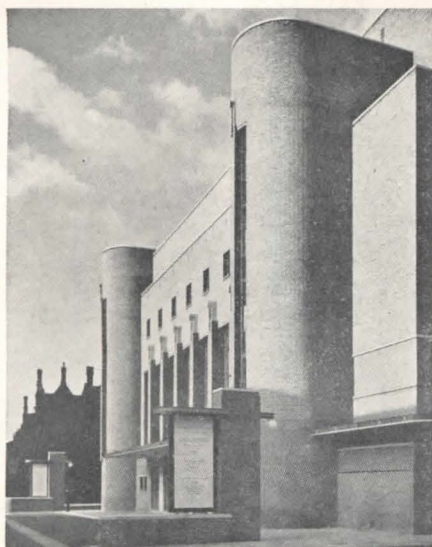

Liverpool Philharmonic Hall. H. J. Rowse, architect. — "Recent English Architecture"

### BRITISH BUILDING

*Recent English Architecture: 1920-1940. Selected by the Architecture Club. London, W.C. 2, England (2-10 Tavistock St.), Country Life Ltd., 1947. 7¼ by 9¾ in. 74 pp. illus. 7s. 6d.*

With these 65 well chosen photographs, a small group of English men and women interested in widening the public appreciation of architecture has succeeded in summing up the best of English building in the past quarter-century and predicting what can be expected in the years immediately ahead.

The group behind the project was a committee of the Architecture Club, whose membership, limited to 300, consists of architects, writers and "persons interested in furthering good building." The illustrations were chosen, the introduction says, "for the contribution the originals make to our heritage of building, whether they are modern or traditional in style. It is misleading to discriminate between buildings by these labels, which are largely a matter of fashion. There is truth in the saying that it is traditional to be modern; the important thing is that modern buildings shall be worthy of the national tradition, whatever form they assume."

Grouped according to type — public buildings, social services, office buildings and business premises, ecclesiastical, educational, domestic — the photographs are allowed to speak for themselves except for very brief captions. The book thus is in effect an exhibition, and ideally suited to study and analysis.

Low-cost housing has been omitted as too broad a subject to be treated in so

brief a book, but the several apartment developments included make up in large part for this lack. All in all, the selection is well rounded and well presented.

### MORE MAYA

*The Ancient Maya. By Sylvanus G. Morley. Stanford University, Calif., Stanford University Press, 1946. 6 by 9 in. xxxii + 520 pp. illus. \$10.00.*

"Maya stone architecture is as distinctive as Greek, Roman, or Gothic," says Dr. Morley. "It has its own canons, its own structural practices, its local variations, but fundamentally it is one. . . . It was inevitable, given the high intelligence and native genius of the ancient Maya, coupled with their strong religious fervor, that they should develop a great religious architecture of their own, which is just what they did. Beyond the immediate needs of their domestic economy — corn-planting, pottery-making, and weaving — no other activity consumed so much of their remaining time and energy as did their architecture."

This is an absorbing book. Familiar with every side of Maya life as reconstructed from excavation and research, Dr. Morley has brought the ancient civilization almost back to life in this volume. His own explorations and study, which he here sums up, have covered the past 40 years and have brought him into close contact with the present-day Mayans.

What Dr. Morley has given us is a history of a civilization. Everything is here from a description of the region where the Maya lived and of the people themselves to their abilities and achievements (notably in the fields of astronomy and mathematics), their manners and their customs. Of particular interest is his comparison of the Maya with two other early American cultures of note — the Inca and the Aztec.

### TECHNICAL BOOKS

#### STEEL MANUAL

*Steel Construction: A Manual for Architects, Engineers and Fabricators of Buildings and Other Steel Structures. 5th ed. New York (101 Park Ave.), American Institute of Steel Construction, 1947. 6 by 9 in. 432 pp. illus. \$2.00.*

This latest edition of the A.I.S.C. Steel Manual has been substantially revised in two sections — the Specification for the Design, Fabrication and Erection of Structural Steel for Buildings, and the Code of Standard Practice for Steel Buildings and Bridges. Also, to conform to lists agreed upon by industry since the end of the war, the tables of

available rolled shapes have been "radically revised," and the various tables throughout the Manual have been correspondingly corrected.

Apart from these necessary revisions, the Manual follows previous editions: Part I contains data most frequently referred to by structural estimators and designers; Part II, the data required in making shop drawings; Part III, tables of allowable loads; Part IV, standard specifications and codes; and Part V, miscellaneous data and mathematical tables for ready reference.

### SIMPLIFIED FILING

*A.I.A. Standard Filing System and Alphabetical Index: 1947 Edition. Washington 6, D.C. (1741 New York Ave.), The American Institute of Architects, 1947. 8½ by 11 in. 64 pp. \$2.00.*

*The American Institute of Architects Filing System for Architectural Plates and Articles. 2nd ed. Same as above, 1946. 8½ by 11 in. 20 pp. \$1.00.*

Here are two new editions of standard A.I.A. documents, especially compiled to simplify architects' filing problems. The first, for the filing of information on materials, appliances and equipment, has been revised to correspond more adequately to filing needs not only directly related to construction generally but to activities related thereto; it now contains 41 major divisions, the titles of which conform in general with the headings of a comprehensive construction and mechanical equipment specification. The second booklet, providing a simple method for the filing of architectural plates and articles, has been made more valuable and more easily used by the addition of a detailed alphabetical index.

### CITY PLANNING

#### GLENDALE, OHIO

*The Village Plan: Glendale, Ohio. Prepared by Harland Bartholomew & Associates. Glendale, Ohio, Village Planning Commission, 1947. 7 by 9 in. 78 pp. illus.*

Glendale's 2400 or so residents do not believe, obviously, in waiting to lock the stable until their horse has been stolen. Their village is unusually attractive, with well laid out streets, an air of spaciousness, and only a small area which might be considered blighted. Yet in 1942 Glendale engaged city planners Harland Bartholomew & Associates "to prepare a village plan." The resulting report on conditions and prospects is highly favorable.

Glendale's chief problems, the report indicates, are protection of the village from adverse use of adjacent land and maintenance of residential amenities within the village itself. Certain re-

(Continued on page 30)



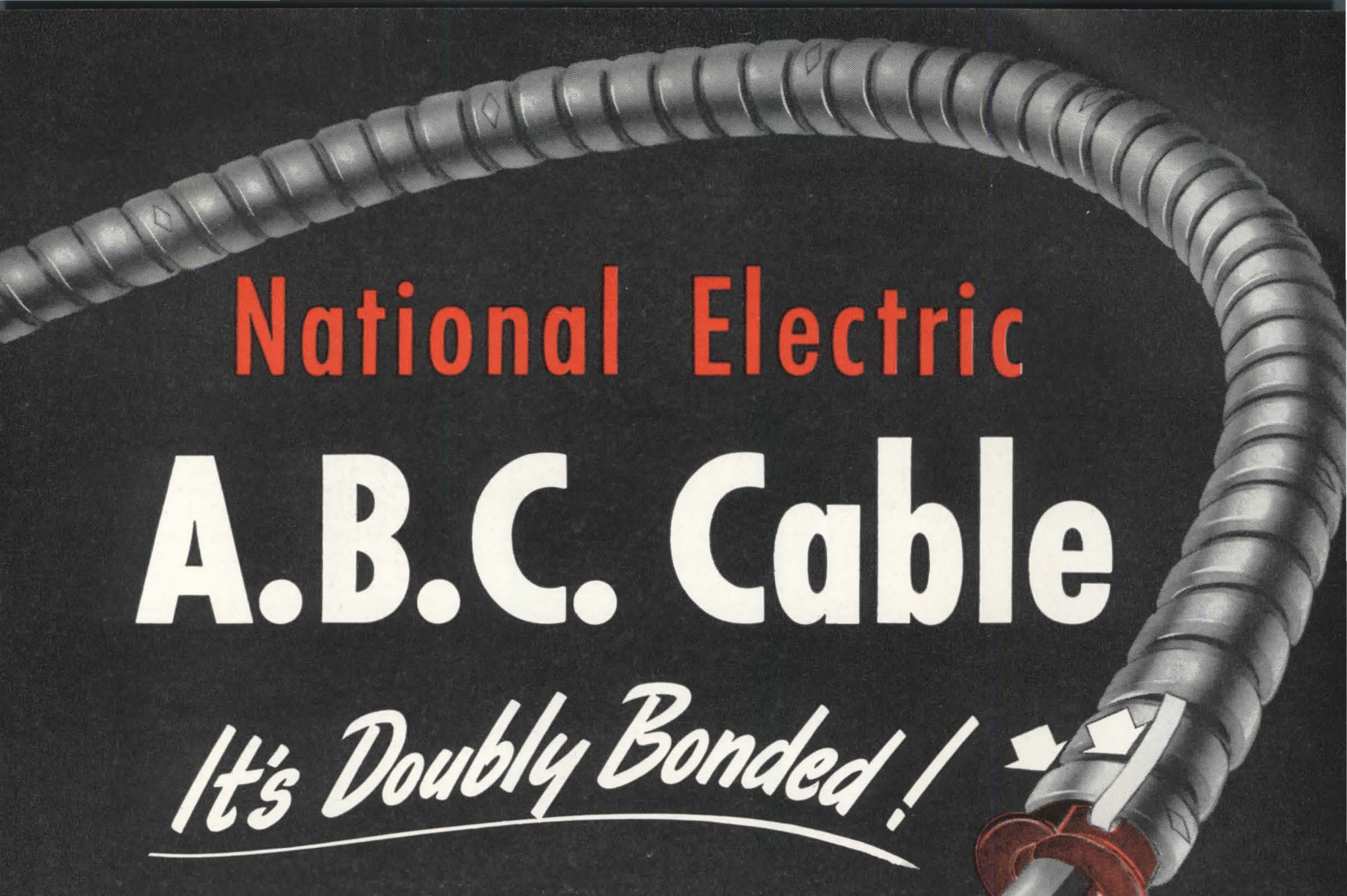

# National Electric A.B.C. Cable

*It's Doubly Bonded!*

There's no real substitute for *Armored, Bonded and Bushed* Cable!

It is the only general-purpose, *ready-to-use*, metal-protected, approved system of wiring!

It provides the lowest cost, *METAL-ENCLOSED* wiring system, and guarantees a *SAFE, FOOLPROOF* installation!

*And Now*— **TWO** Paths to Ground for sizes No. 14 and No. 12!

- ➡ 1. A new, low-resistance, flat, grounding strip in contact with the armor.
- ➡ 2. The armor itself with "bondhook" channel construction to assure a positive path to ground.

(Sold through leading electrical wholesalers)

**National Electric Products Corporation**  
**Pittsburgh 30, Pa.**



## OTHER A. B. C. FEATURES

"Dilec Firestop" insulated wires—Moisture resistant, flame retardant, easy to strip.

Anti-Short Bushing—Protects the wires from sharp armor edges.

Flexibility without interfering with grounding contact between armor convolutions.





## KNEE HIGH OR FIVE FEET OVER YOUR HEAD

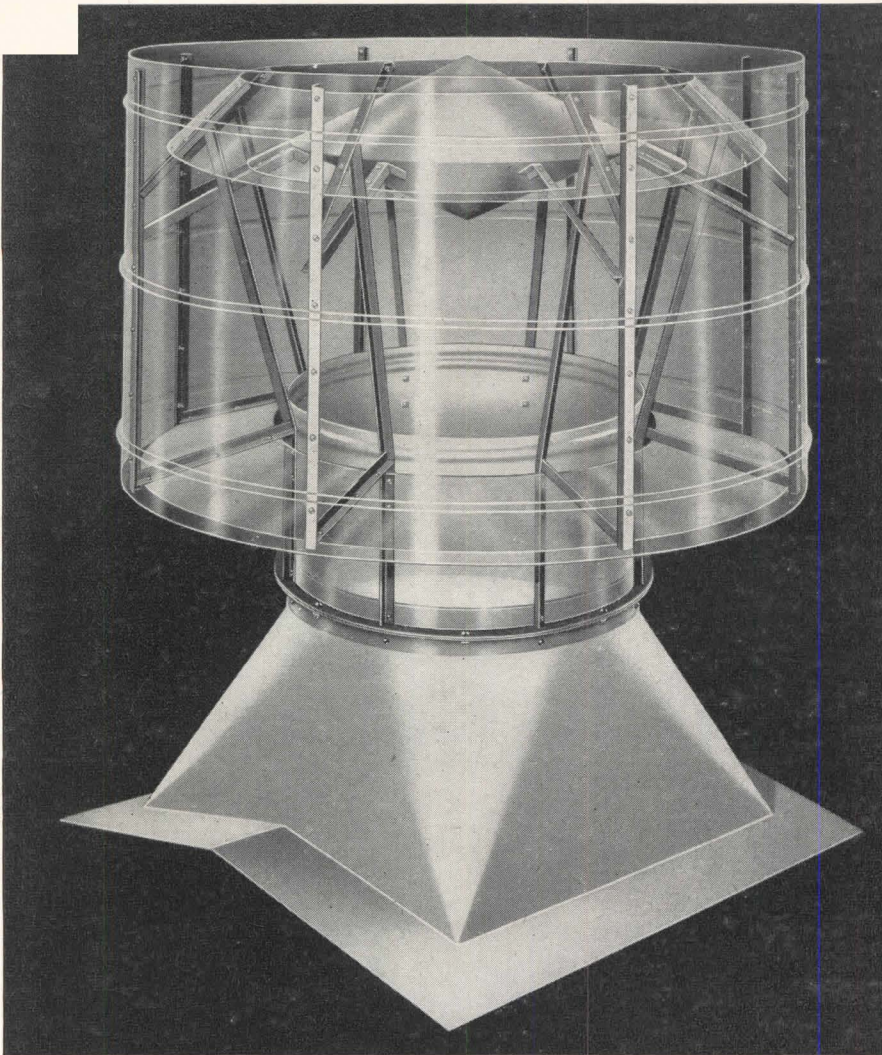

### BURT FREE-FLOW GRAVITY VENTILATORS ARE SIZED TO SUIT YOUR NEEDS

An 8" Burt Free-Flow Gravity Ventilator is tiny in comparison with the giant 96" unit that stands almost eleven feet in height and exhausts 100 times as much air. Yet each finds many applications in industry. The Burt line is complete. It includes gravity, fan, revolving head and continuous ridge ventilators in a full range of sizes. Burt Engineers can recommend—without bias—the type best suited to your needs. Their assistance is available without obligation—to help you lay out plans and submit specifications. See Sweet's or write for catalog and data sheets on the complete Burt ventilating line—NOW!

WRITE FOR CATALOGS AND DATA SHEETS

*The* **BURT MFG. Co.**

48 E. South Street

Akron 11, Ohio, U.S.A.

VENTILATORS, LOUVERS, OIL FILTERS AND SHEET METAL SPECIALTIES

## REQUIRED READING

(Continued from page 28)

habilitation and rebuilding are recommended, much of it in the Negro development; a proposed street plan calls for widening of three major thoroughfares, construction of an underpass under the railroad tracks, and development of new minor streets if and when required. Other recommendations include enlarged and new play areas and parks and a landing field for helicopters. Of particular interest is the proposal to create a "municipal forest" along the entire southern border of the village and part of the northern to act as a buffer strip which, in conjunction with the cemetery and institutions immediately adjacent to the village limits would ring Glendale with a zone of public and semi-public property.

It is encouraging to note that some progress already has been made toward the realization of this plan. The zoning ordinance and the minimum standards housing ordinance have been adopted, and part of the land for the proposed municipal forest has been acquired.

### CHICAGO

*Woodlawn: A Study in Community Conservation. Prepared by the Chicago Plan Commission in Collaboration with the Woodlawn Planning Committee. Chicago, Ill., Chicago Plan Commission, 1946. 8½ by 11 in. 76 pp. illus.*

This report on the existing conditions and the needs of one small residential section of Chicago, is an analysis of "the problems common to most of the middle-aged Chicago residential areas." Following the outlines and the precepts of the comprehensive plan for the city as a whole, it establishes community and neighborhood boundaries, designates certain streets to be developed as major thoroughfares, makes concrete parking recommendations, specifies the location and extent of essential school and play areas, and in general outlines a conservation and development program aimed at making Woodlawn an attractive and economically sound residential community.

### HOSPITAL PROGRAMMING

*The Hospital Act and Your Community. Washington 25, D.C., Federal Security Agency, U. S. Public Health Service, Division of Hospital Facilities, 1947. 5½ by 8 in. 16 pp. illus. Single copies gratis.*

Here is a small booklet explaining in simple terms the Hospital Survey and Construction Act, what it is, and how it works. Intended to help any group or community interested in building a hospital, it tells how to go about getting federal aid, and presents some of the statistics which brought the Act into being in the first place.



**NO MORE STARTER SWITCHES**

*Mean*

**NO MORE STARTER TROUBLES!**

**Guth Quick-Liter**

TRADE MARK

**FLUORESCENT LIGHTING THAT'S SIMPLE!**

Ordinary Fluorescent Fixtures, fitted with conventional Starter Switches, frequently result in confusing, high cost maintenance. When Lamps stop burning, it is often very difficult to determine whether the Lamp or the Starter needs replacing.

With GUTH Quick-Liters, there are no Starter Switches—so there are no questions! When a Lamp goes out, it's a dead Lamp! Result—easier, quicker, more certain maintenance. Also, much longer usefulness—

since each Lamp supplies illumination to the end of its life!

Check the many additional advantages of GUTH Quick-Liters:—light at the flick of a switch—start and operate at temperatures as low as 0° F, or on low or irregular voltage—mass-produced for lower initial cost and more economical installation cost. These advantages readily explain why Quick-Liters are the final word in *Good Fluorescent Illumination*.

WRITE TODAY FOR INTERESTING MATERIAL  
ON THE FEATURES OF GUTH QUICK-LITERS

**MANY ATTRACTIVE, EFFICIENT *Guth* FLUORESCENT LUMINAIRES  
MAY BE EQUIPPED WITH QUICK-LITER BALLASTS**

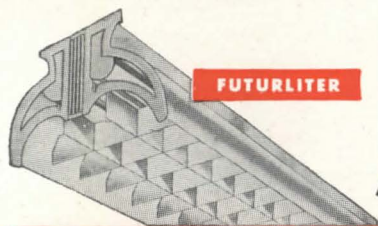

FUTURLITER



ARISTOLITE



LIGHTRONICS

Leaders in **LIGHTING** Since 1902

★ ★ ★ **THE EDWIN F. *Guth* COMPANY** ★ ★ ★  
2615 WASHINGTON AVE. ST. LOUIS 3, MISSOURI



# IBM Electric Clock Systems Coordinate Activities in any Building

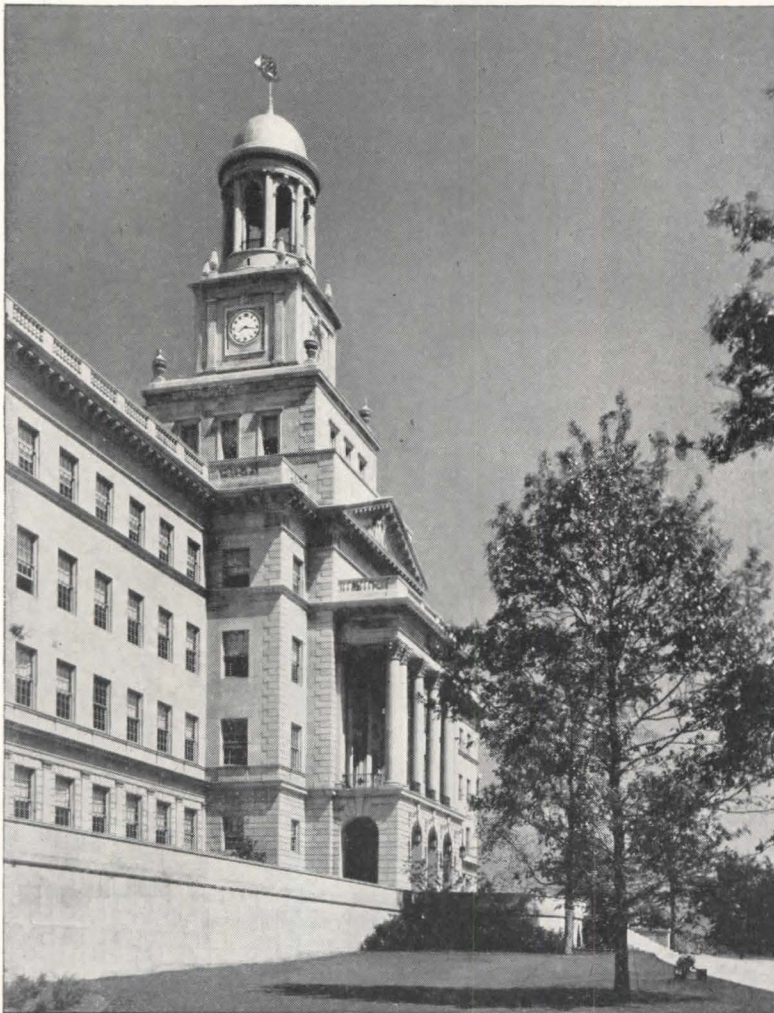

**IBM** Electric Clock Systems provide control over all operations by maintaining one accurate standard of time throughout a building.

One IBM Master Time Control unit regulates automatically all wall, corridor, and tower clocks, attendance time recorders, job cost recorders, and time stamps. Bells, horns, and buzzers, synchronized with the Program Control unit, can be sounded to meet any schedule.

The same accurate time indicated on IBM clocks is printed on records of attendance time and job cost, as well as on letters, telegrams, and other important documents, thereby providing management with accurate records for control of operations. IBM Electric Time Systems are available for either direct or alternating current operation.

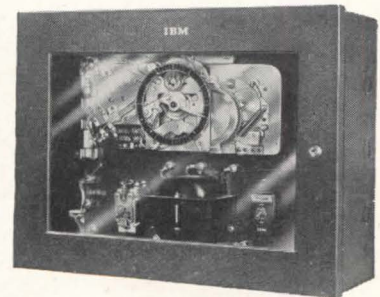
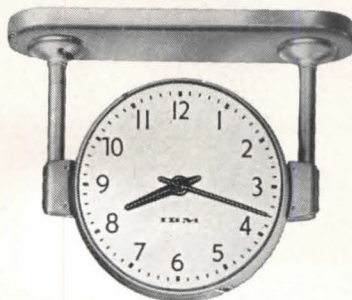
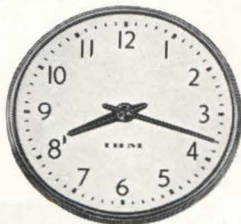

# IBM

## TIME RECORDERS AND ELECTRIC TIME SYSTEMS

Proof Machines • Electric Punched Card Accounting Machines  
and Service Bureau Facilities    Electric Typewriters





## Something New and Interesting in FORMICA Patterns...

**H**ERE are three new Formica patterns, provided in many shades and colors. They are attractive, novel and serviceable and supplement the linen patterns which were introduced by Formica some twenty years ago. The new line of modern, well harmonized, solid colors are in production and again available

The patterns and colors have all the usual

Formica qualities. They do not stain with colored liquids; they are not spotted by solvents like alcohol or by mild acids or alkalis such as are present in fruit, or cleaning solutions; for horizontal surfaces they are available in the cigarette proof grade. And because of the wide range of colors and shades they will harmonize with any decorative scheme.

*Reproductions of the entire range of colors are sent on request.*

**THE FORMICA INSULATION COMPANY**  
4613 Spring Grove Ave., Cincinnati 32, Ohio

**FORMICA**

REG. U.S. PAT. OFF.



# Gruen & Krummeck design a commercial building

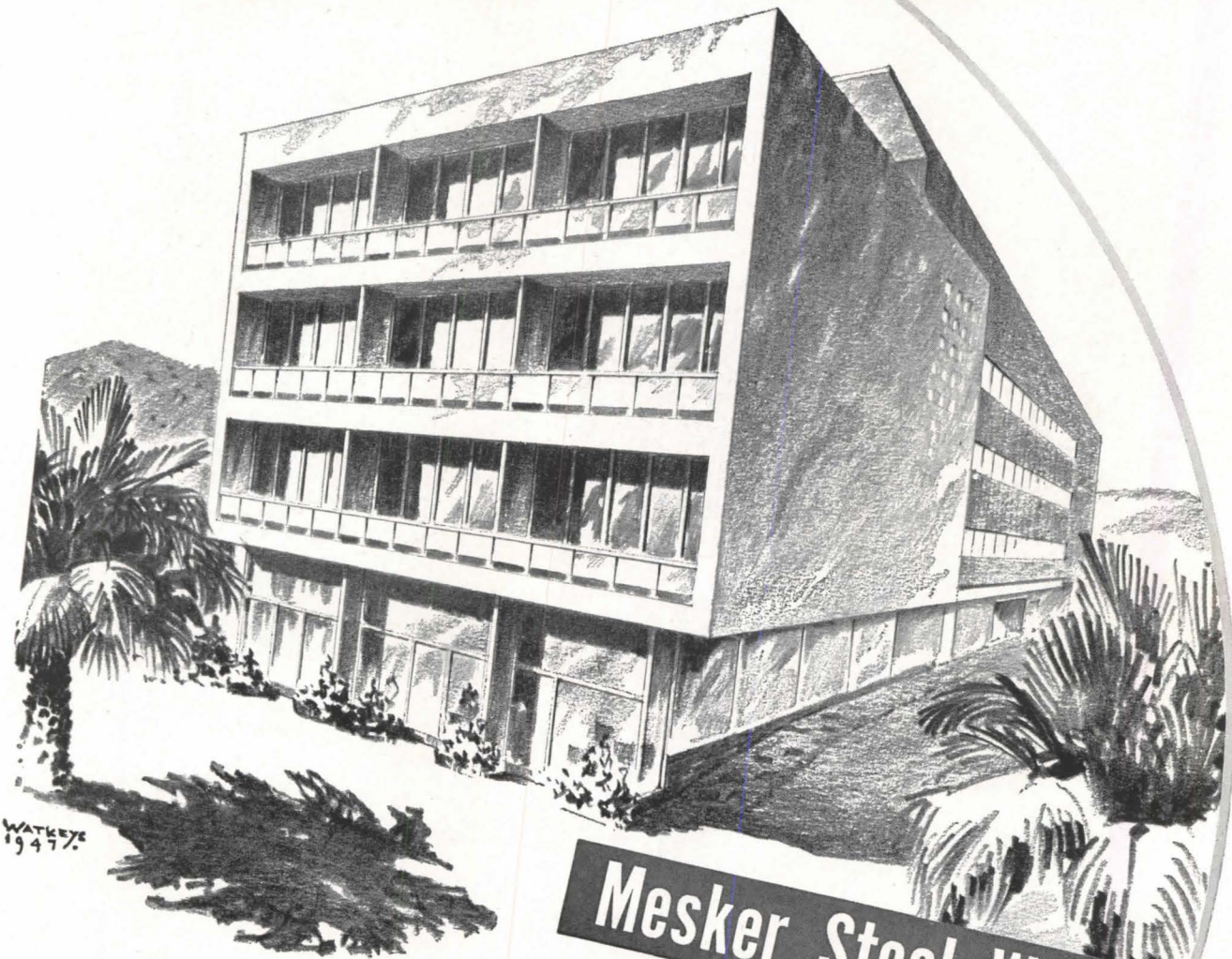

## Mesker Steel Windows

"For ample ventilation, for protection against weather, fire and intruders, nothing takes the place of sturdy steel in windows for commercial buildings."



For your copy of the Mesker Book of Windows for Office Buildings, write to Mesker Brothers, 4338 Geraldine Avenue, St. Louis 15, Mo.

Design by  
Gruen and Krummeck  
Associates  
Hollywood, Cal.



# RCA *Unit-Built* SCHOOL SOUND SYSTEM

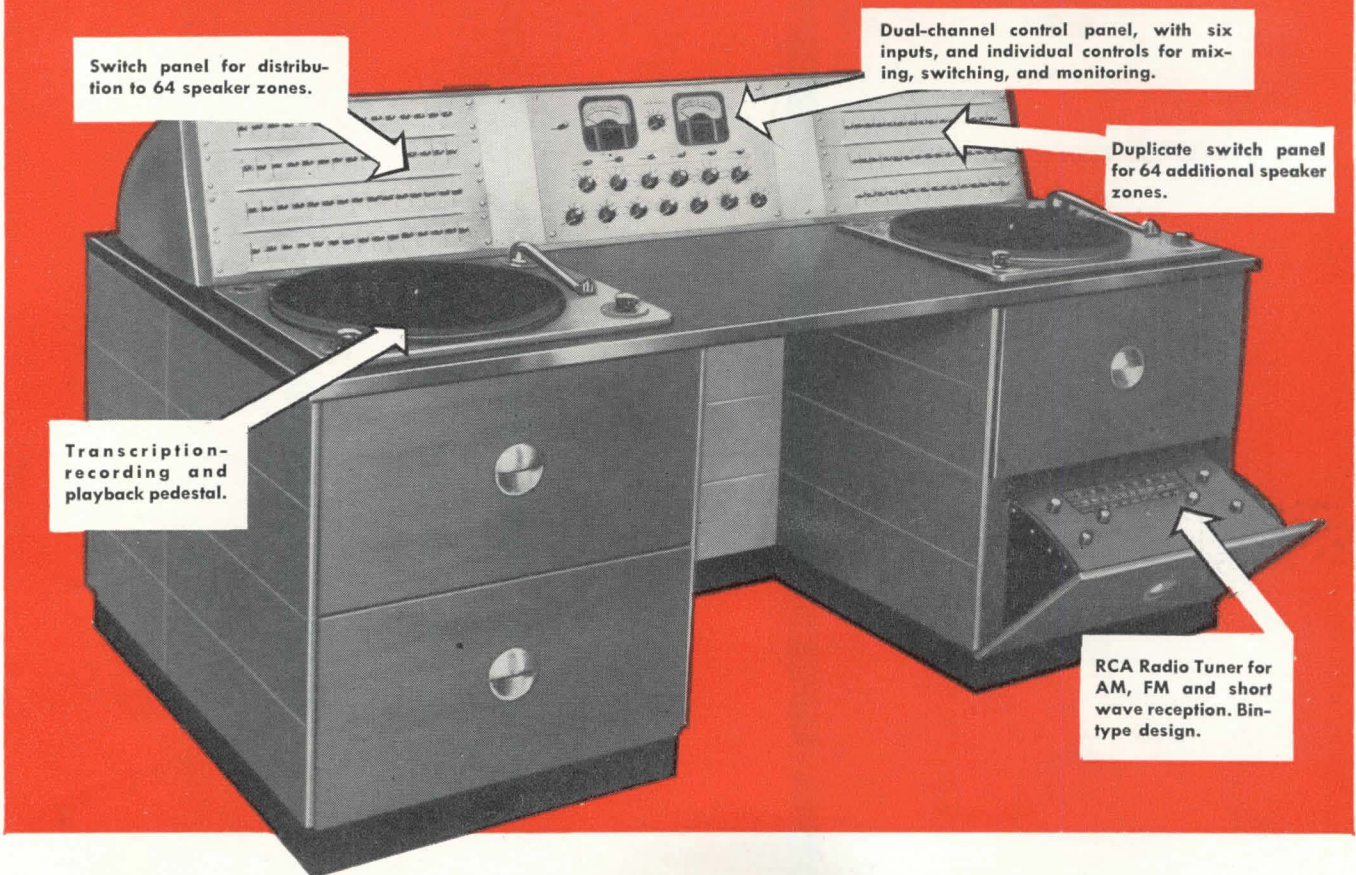

**Complete sound facilities . . . correct styling . . .  
standardized dimensions . . . functional design**

RCA's unit-built sound equipment simplifies the application of sound facilities to the varying requirements of individual schools. Standardized frames and panels are matched to make up distinctly styled basic units. Combinations of the various units by functions provide efficient sound control and complete facilities for all types of schools.

A typical Master Sound Control Console, assembled from RCA basic units, is shown above. In this case five units are used . . . providing any desired combination of program sources to as many as 128 loud-speaker zones. It provides "custom-

built" performance within the price range of production equipment.

This RCA development follows long specialization in institutional sound equipment. Make use of RCA's experience when planning for sound

systems in schools and other institutional buildings.

For complete specifications on the various unit-built sound combinations, write: Dept. 10-H, Sound Equipment Section, RCA, Camden, N. J.

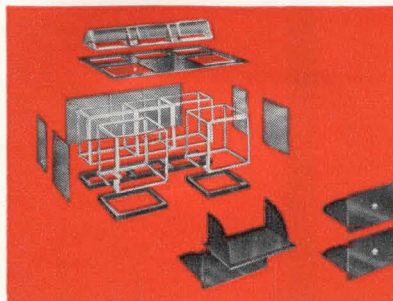

*Unit-Built*  
**for full flexibility**

Standardized frames and panels allow an extremely wide range of combinations, to cover all existing and future sound requirements.



**SOUND SYSTEMS**  
**RADIO CORPORATION of AMERICA**  
**ENGINEERING PRODUCTS DEPARTMENT, CAMDEN, N. J.**

In Canada: RCA VICTOR Company Limited, Montreal





GAS RANGES

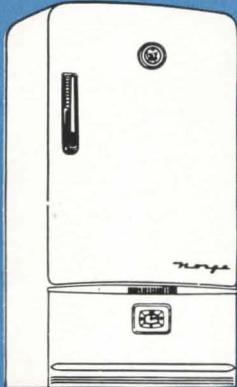

REFRIGERATORS



ELECTRIC RANGES

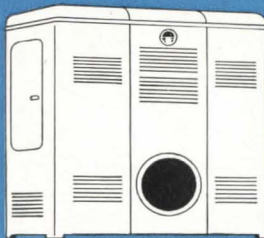

HOME HEATERS

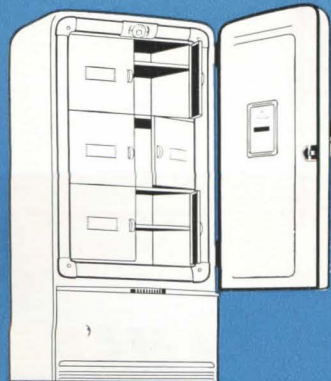

HOME & FARM FREEZERS



WASHERS



ELECTRIC WATER HEATERS

## FROM THE LAUNDRY... TO THE LIVING ROOM

These vital home services are superbly performed by Norge: Water is heated, clothes are laundered, food is cared for and cooked, rooms are kept warm. *Satisfaction-equipped* is an apt synonym for *Norge-equipped*.

Norge is the trade-mark of Norge Division, Borg-Warner Corporation, Detroit 26, Michigan

SEE  
**NORGE**  
BEFORE YOU BUY

Products of  
BORG-WARNER





# Announcing **OAKTRED**

THE ONE-PIECE FLOOR THAT HELPS SELL THE HOUSE



*Oaktred is the type of flooring often used in luxurious residences like this...*

OAKTRED, the modern durable one-piece flooring is now in large scale production at the request of the National Housing Agency in order to make this quality flooring available to a much wider field of building operations for both single and multiple dwellings at an economical price.

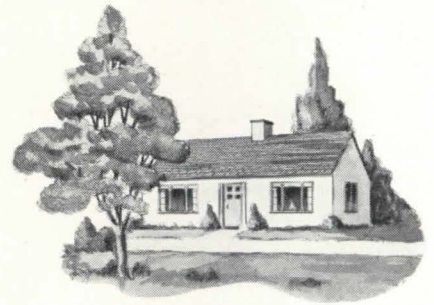

*...now available because of large scale production for low-cost housing like this.*

# OAKTRED

THE MODERN ONE-PIECE FLOORING

OAKTRED flooring, a scientifically formulated composition, is poured in place and sets in one piece. It is seamless, sanitary, fireproof, insect and rodent proof. It is resilient and does not dent, rut or splinter. OAKTRED insulates against heat and cold. It is not a floor covering but a permanent flooring composed of kiln-dried oak flour, asbestos fibres and chemical binding agents.

WRITE FOR FULL PARTICULARS,  
DELIVERIES AND PRICES

**KOMPOLITE**  
**BUILDING MATERIALS INC.**

111-115 Clay St., Greenpoint, Brooklyn 22, N.Y.

For 40 years KOMPOLITE MEANS FLOORS  
FOR EVERY REQUIREMENT—Plastic Mar-  
ble, Terrazzo, Composition, Cement Finish,  
Asphalt Tile, Rubber Tile, Cork Tile and  
Industrial Flooring.

OAKTRED is available for immediate delivery. Comes in a standard oak color and in dry form. Requires only water for mixing on the job. Installed by a mason. Sets in 4 to 6 days and is then sanded and finished. Can be finished in a variety of ways and scored, if desired, to any pattern. Produces a beautiful and durable floor that increases the saleability or rentability of any residence.



# EXCLUSIVE REASONS WHY ARCHITECTS AND BUILDERS FAVOR KIMSUL\*



- 1** **MANY-LAYER CONSTRUCTION**—KIMSUL\* insulation is designed on a scientific many-layer principle...automatically provides uniform coverage over every square inch of insulated area.
- 2** **COMPRESSED PACKAGE**—KIMSUL is delivered compressed to 1/5th installed length and packaged in easily-handled rolls. Requires 1/5th the storage space of non-compressed insulations.
- 3** **EXTRA WIDTH**—The KIMSUL blanket is made extra wide to provide *insulated* fastening edges... and to fill irregularities in framing spaces.
- 4** **USE FOR CAULKING**—Trimmed pieces of KIMSUL are efficient for caulking heat-leaking cracks, such as those around windows and doors—reducing waste.
- 5** **FLEXIBLE BLANKET**—KIMSUL can be easily tucked around obstructions, fitted into non-standard openings, pulled around corners.

KIMSUL insulation is a prefabricated blanket, with uniform thickness built right into it in manufacture. It's simple for anyone to install... just cut to desired length, expand and fasten in place. It's fire-resistant, moisture-resistant, fungi-resistant—termite-proof. And it's lightweight, clean, and odorless... no irritating dust or splinters, easy on workmen's hands. KIMSUL is remarkably efficient for homes, commercial buildings, and industrial construction.

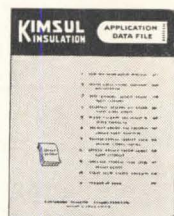

*For you—this helpful Application Data File. Detailed information on the best and easiest ways to insulate new or existing buildings with efficient, easy-to-use KIMSUL. A request on your letterhead will bring your copy.*

**KIMBERLY-CLARK CORPORATION**  
KIMSUL DIVISION

Neenah, Wisconsin

*We are producing all the KIMSUL insulation we possibly can, but due to the great demand, distributors may have some difficulty in supplying KIMSUL dealers as promptly as usual.*

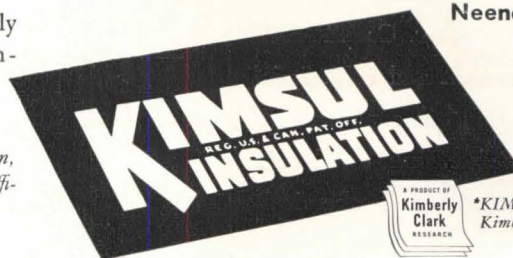



# Rolling Steel

# DOORS

*Manually • Mechanically • Power Operated*

The space saving features, the permanence and greater protection of steel, and the economy of long trouble-free service afforded by Rolling Steel Doors are well known today to both architects and building owners. When you select Mahon Rolling Steel Doors you get the finest in materials and workmanship, and the latest engineering developments in doors of this type . . . you get also, in addition to compactness of design, distinct operating advantages in the Mahon Power Operators. See Mahon's Insert in Sweet's File for detailed information, complete specifications, installation details and clearance dimensions—or consult a Mahon representative.

## **THE R. C. MAHON COMPANY**

Detroit 11, Michigan • Western Sales Division, Chicago 4, Illinois

*Representatives in All Principal Cities*

**Manufacturers of Rolling Steel Doors, Shutters and Grilles, and Mahon Steel Deck for Roofs, Sidewalls, Partitions, Acoustical Ceilings, Permanent Floor Forms and Oversize Doors.**

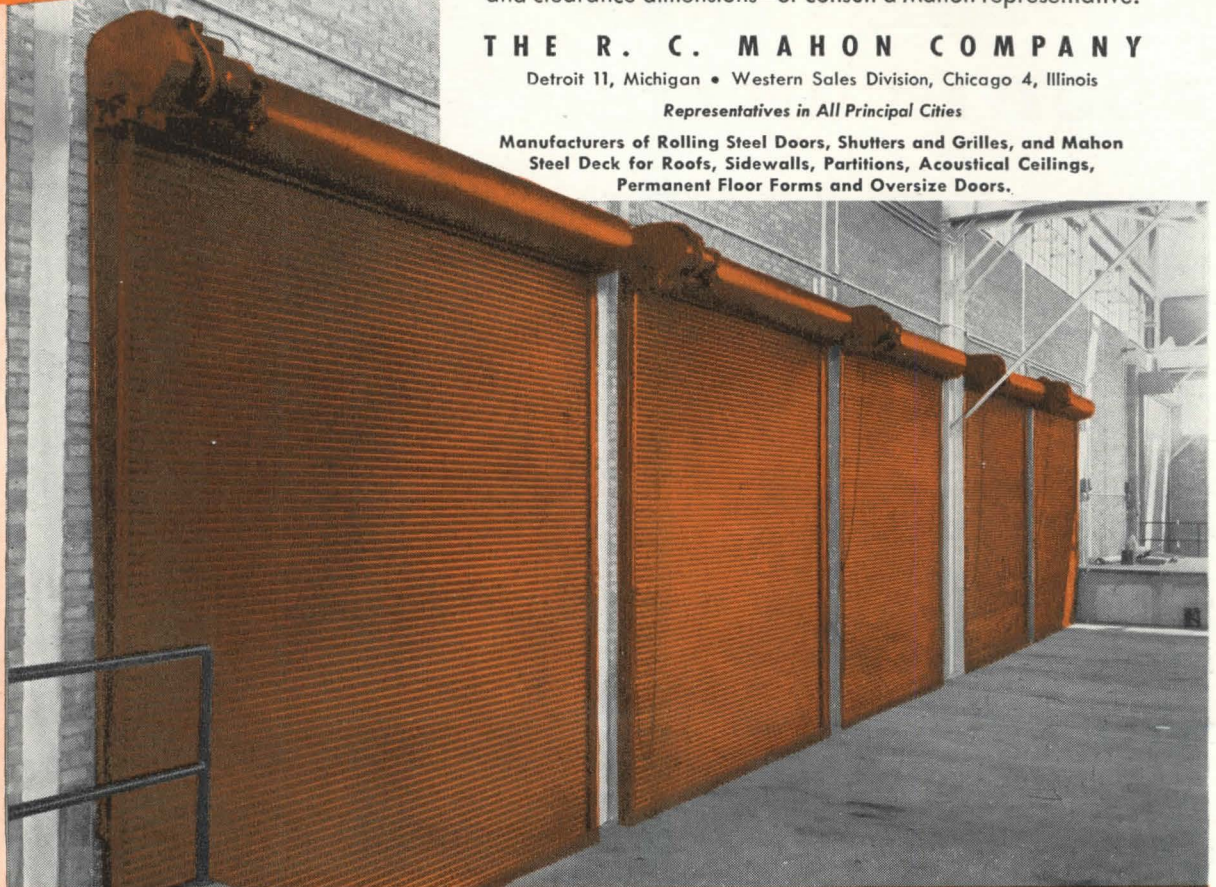
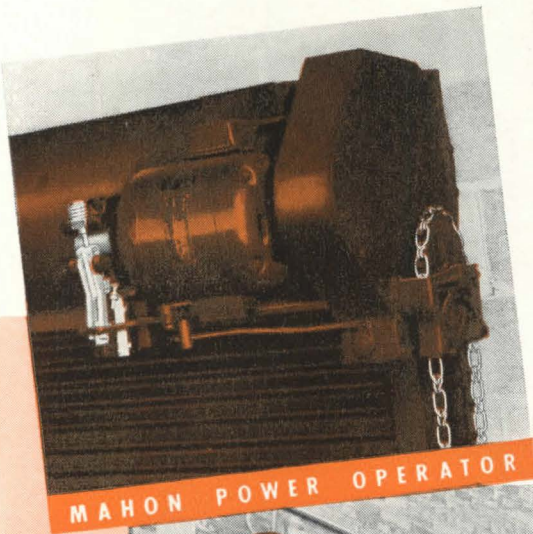

# MAHON



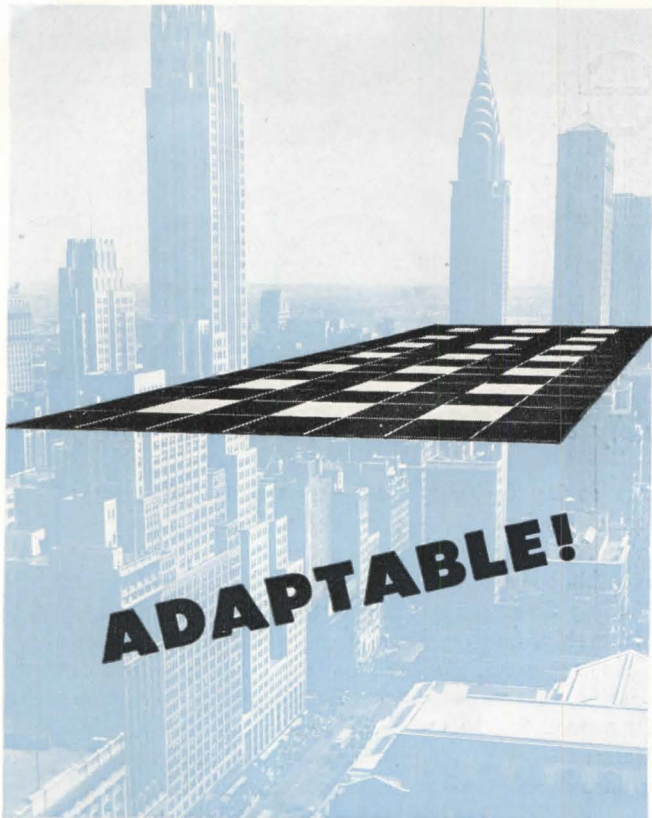

## HOOD RESILIENT TILE

"Adaptable" is the word for Hood Rubber or Asphalt Tile. Architects prefer it because they can make it conform to their own individual flooring requirements in buildings both public and private.

Wide variety in color permits custom-created designs to harmonize with almost any interior. Consistency of quality insures performance while lasting resilience assures the safe kind of quiet comfort that takes the weariness out of walking. Hood's finer flooring does more than just serve the purpose. It actually improves the situation.

You can always count on B. F. Goodrich research ability combined with Hood production skill for the kind of resilient flooring architects expect and their clients deserve.

See Sweet's Architectural File or send for catalog in color.

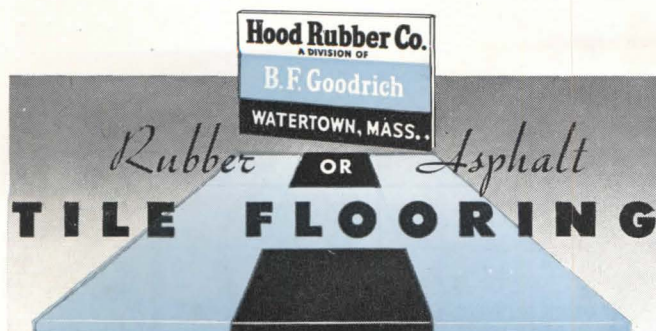

*But what makes these rooms*  
**SO DIFFERENT — SO DISTINCTIVE?**

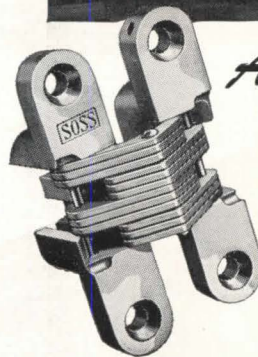

*A logical question*  
*—often asked!*

The answer may be that the visitor does not see door hinges anywhere. Hinges are present to be sure—but they are not visible to the eye. They

are Soss Invisible Hinges.

When Soss Invisible Hinges are a feature of building design, the architect is enabled to employ flush surfaces for doors, panels and cupboards. He can then obtain the streamlined effects which provide so modern and distinctive a touch to home interiors. Your clients will appreciate these modern hinges and the results they make possible.

Write for Soss "Blue Print Catalog" giving full details of these modern hinges. Free on request.



**SOSS MANUFACTURING COMPANY**  
21765 HOOVER ROAD • DETROIT 13, MICHIGAN





ANDERSEN

# Windowalls . . . . LOOKOUT POINT FOR BEAUTY

These windows that are walls . . . these walls that are windows . . . are a perfect expression of a design trend that has been accepted universally by progressive architects and designers.

Here ANDERSEN® Wood Casement Units are arranged on either side of an expansive picture window—and, beyond, a corner installation is formed by a combination of the same out-swinging casements.

Note the emphasis placed on operating sash—providing ample ventilation for this lakeside home. This is the way to combine view, sunshine, ventilation and weather-tight comfort. It's the ANDERSEN WINDOWALL way.

McEnary and Krafft, architects, designed this installation, and specified ANDERSEN Complete Window Units to bring their inspiration into reality.

See details in Sweet's—or write Andersen directly.

*Andersen Corporation*  
BAYPORT • MINNESOTA





# Ambassador by Lockwood

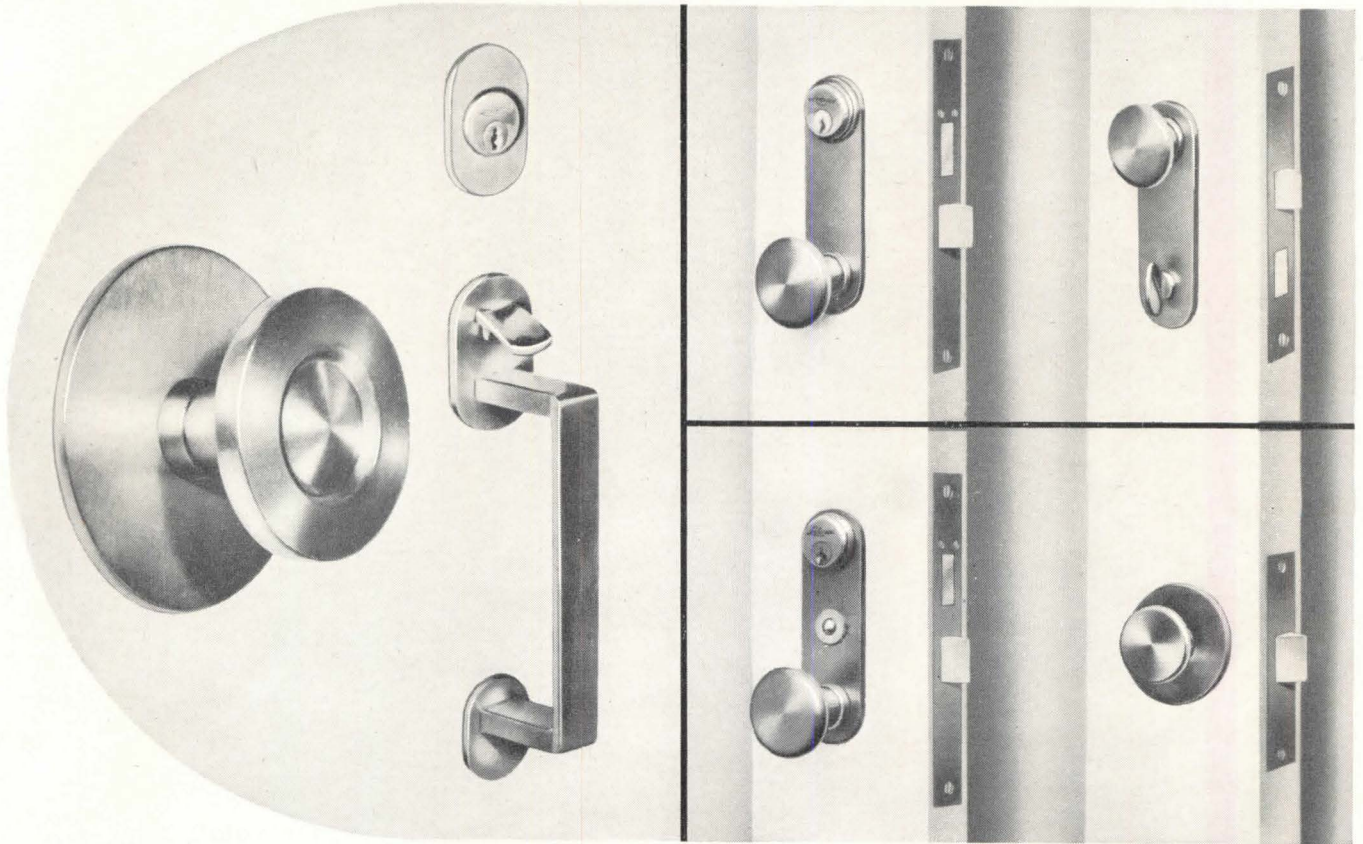

**... classic in builders' hardware**

Quality shows up best in simple designs. Like the plain pattern in *sterling*, Lockwood's Ambassador Hardware brings out the classic beauty of solid bronze. The use of three distinctly different knobs with one design has been enthusiastically acclaimed by the architectural profession.

Lockwood's method of concealed screws, developed for Ambassador, lends charm to the design and furnishes complete satisfaction in use.

When you write your specifications with Lockwood's Ambassador Hardware you provide a *sterling* pattern, available in style and function for every type of door.

L-73A

*Lockwood*  
**lockwood  
builders'  
hardware**



**LOCKWOOD HARDWARE MANUFACTURING COMPANY**  
Division of Independent Lock Company • Fitchburg, Massachusetts





*Designed*  
*for* **APPEARANCE**  
*and* **UNIFORM HEATING COMFORT**

Today prospective home owners want a modern heating installation that will "blend" into the gracious atmosphere of the home they have dreamed of so long.

Vulcan Baseboard Radiation does just that — you have to look *twice* to see it . . . experience its uniform heat but *once* to appreciate it.

A proven heating design for over 20 years, Radi-Vector—Vulcan Baseboard—presents no drawing-board or installation problems. Light in weight, compact and requiring but few fittings, it can be installed for either hot water or two-pipe steam heating systems.

Fin-on-tube construction with attractive solid front grille combines both radiant and convection heating, producing a continuous gentle circulation of uniformly warm air throughout the room. Recessed in the baseboard, Vulcan Radi-Vector allows maximum space for arrangement of furniture . . . does not detract from interior decoration . . . adds spaciousness and graciousness to rooms large or small.

**There's only one Vulcan.**  
*Representatives in principal cities.*



**THE VULCAN RADIATOR CO.** 26 FRANCIS AVENUE, HARTFORD 6, CONN.  
RADIATOR MANUFACTURERS FOR OVER TWO DECADES



# FLEXSTONE BUILT-UP ROOFS

... guard against flying brands

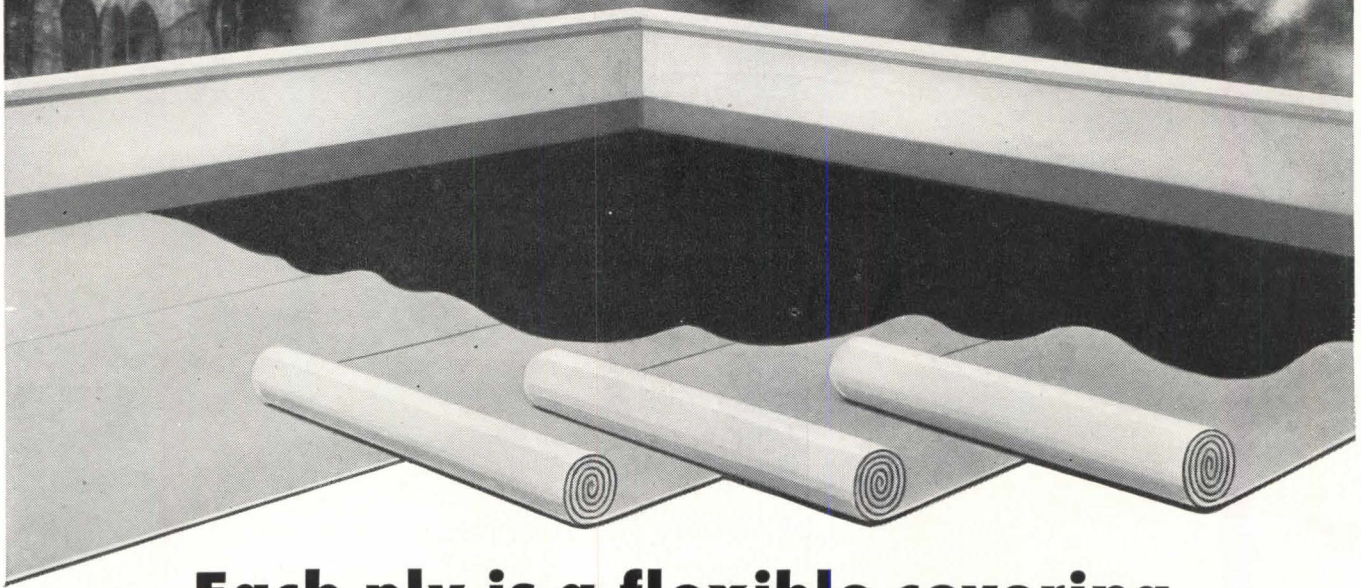

**Each ply is a flexible covering  
of stone—made of asbestos**

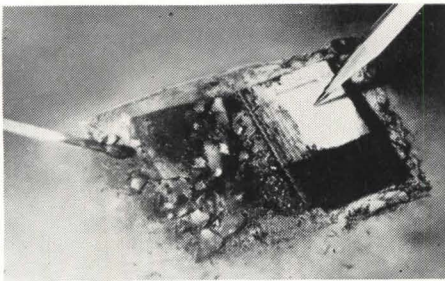

**Make this Fire Test!** The ordinary roofing felt on the left side was reduced to ashes by the consuming flame. But the J-M Asbestos Felt on the right remained unharmed . . . proving its fire resistance. We'll gladly send you the materials to make this convincing test yourself.

Protect your building from the hazard of flying sparks and burning embers. Insist on a Johns-Manville Flexstone Roof. *It will not support combustion.* That's because the felts in a J-M Flexstone Built-Up Roof are made of the magic mineral *asbestos*—fireproof, rotproof, long-lasting.

Flexstone Roofs are *smooth-surfaced*, too—permitting thorough drainage, eliminating the weight of slag or gravel, and making any damage easy to locate and repair. Need no periodic coating. Felts are perforated to insure smooth application.

All Flexstone Roofs are engineered to the particular requirements of your building—whether it's new construction or re-roofing. To insure skilled application, they are applied only by J-M Approved Roofers.

Three types available: Flexstone *Super "A," Standard,* and *Service*—each the finest that can be specified for its purpose. Write for brochure BU-51A, containing complete specifications. Johns-Manville, Box 290, N. Y. 16, N. Y.

Because of unprecedented demand, there may be times when we cannot make immediate delivery. Please anticipate your needs.



**Johns-Manville**

**FLEXSTONE BUILT-UP ROOFS**



*When you think of*  
**BRASS PIPE... "85"**  
*think of* **85**

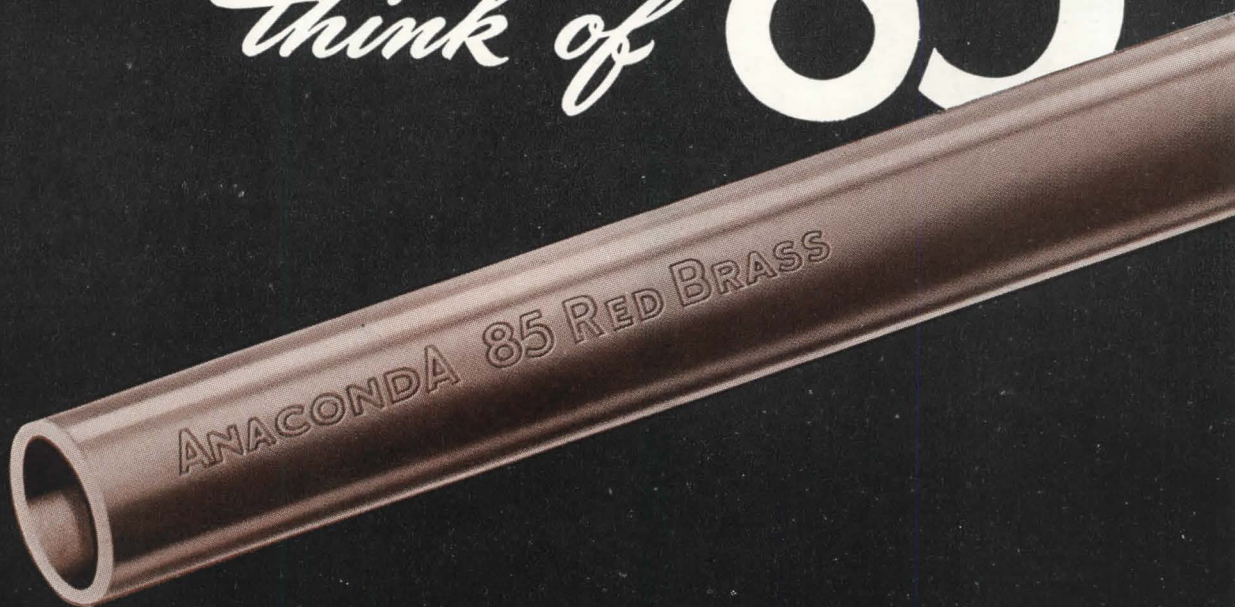

**O**VER THE PAST 20 years, thousands of commercial and industrial installations have utilized millions of feet of Anaconda 85 Red Brass Pipe which, today, continues to give dependable, rust-free service.

This service record justifies the faith of The American Brass Company's engineers who recommended this pipe in 1927 (after ten years of exhaustive experiments) as the highest quality corrosion-resistant pipe obtainable at a reasonable price.

Today this same pipe, containing 85 per-

cent of copper, sets new records for continuing high quality, uniformity of grain structure and proved dependability. It is furnished through wholesale distributors.

4735A

ANACONDA  
from mine to consumer

*Anaconda*

**85 RED BRASS PIPE**

**THE AMERICAN BRASS COMPANY**

General Offices: Waterbury 88, Connecticut

Subsidiary of Anaconda Copper Mining Company

In Canada: ANACONDA AMERICAN BRASS LTD.  
New Toronto, Ont.



Another ★ in the Kewanee Line

{ for Heating Medium Size Buildings }  
{ Dependably with High Efficiency }

# KEWANEE

## SQUARE-HEAT TYPE R BOILER

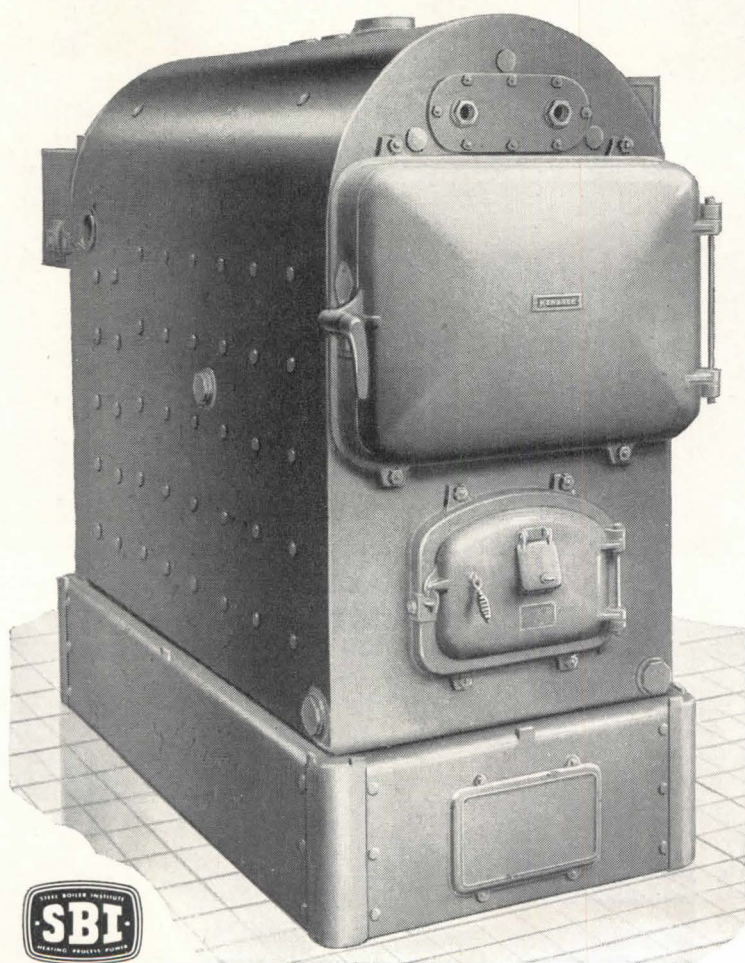

● The Kewanee Square Heat Boiler is an improved "streamline" version of previous Type R models, redesigned and simplified in one super-fine series. These eight new 3R units incorporate all the features which have made the 16 sizes of Kewanee Type R so popular during the last seventeen years.

● This Square Heat Series takes in the upper bracket ratings as developed in the Steel Boiler Institute Code for residential boilers . . . making it ideally suited for heating medium size buildings with unusually high efficiency.

● For Oil, Gas or Coal (stoker or hand fired) and easily and quickly converted from one fuel to another. You can switch from oil to gas and back again, and a change to coal requires no alterations in the boiler proper.

Eight Sizes for 740 to 3000 Square Feet Steam, S.B.I. Net Rating.



Reg. U. S. Pat. Off.  
MEMBER



**KEWANEE BOILER CORPORATION**  
KEWANEE, ILLINOIS

Branches in 60 Cities—Eastern District Office: 40 West 40th Street, New York City 18

Division of AMERICAN RADIATOR & Standard Sanitary CORPORATION

OVER  
75 YEARS  
BOILERMAKERS



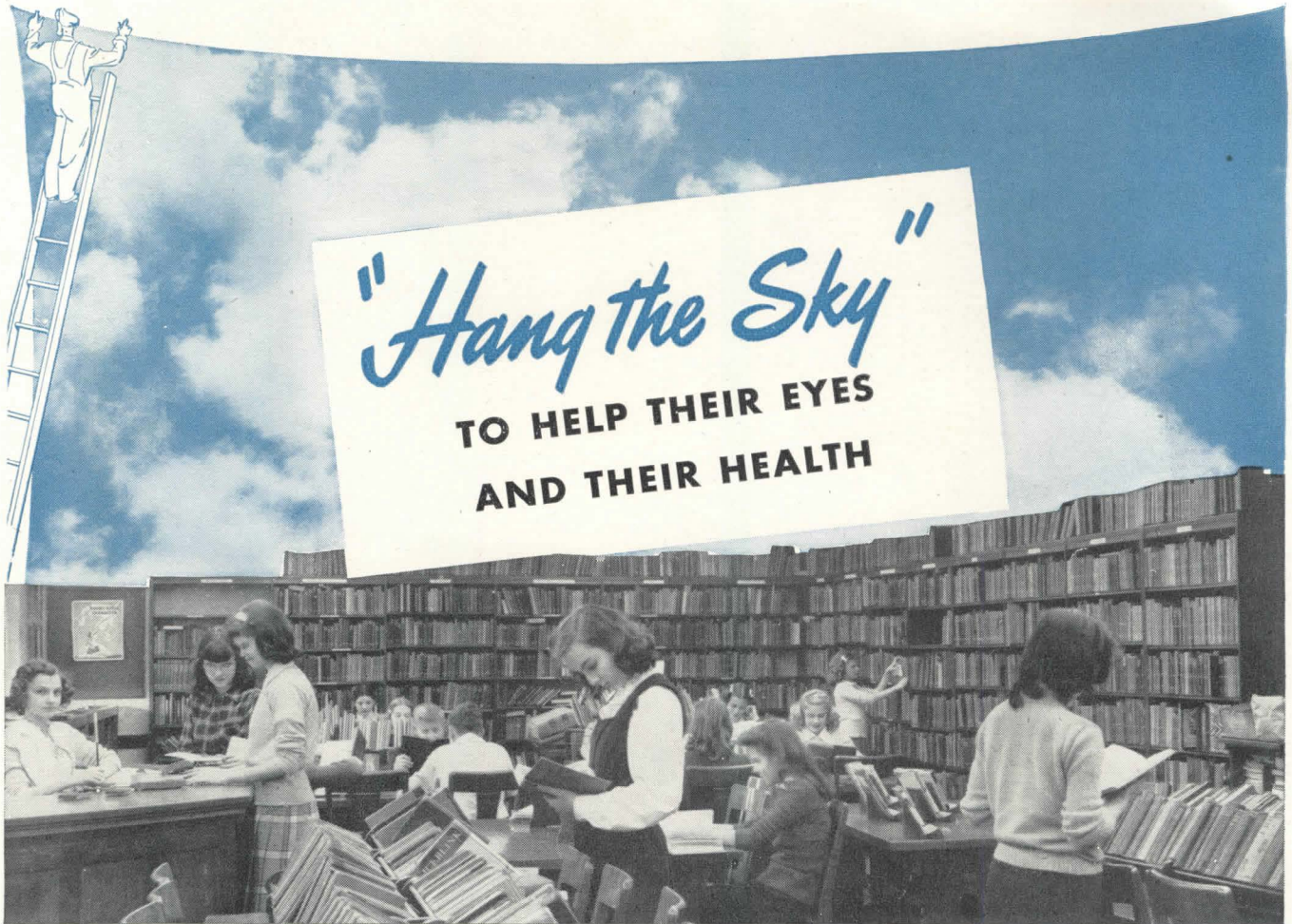

**SPECIFY**  
*Wakefield* Over-ALL Lighting

Just imagine a chunk of sky to light every classroom! That suggests the light quality you create with Over-ALL Lighting by Wakefield . . . soft, diffused, eye-pleasing light spread over all . . . whenever it is wanted!

Pupils like it, and so do teachers . . . because it makes for greater eyesight protection, easier teaching and learning, less strain. And continuing school studies indicate that proper lighting actually improves child health.

Ask your local Wakefield distributor or the lighting engineer of your power company about this basic idea in school lighting. Or write for Wakefield Catalog 46. The F. W. Wakefield Brass Company, Vermilion, Ohio.

*Wakefield*

LIGHTING EQUIPMENT FOR OFFICE, SCHOOL AND DRAFTING ROOM

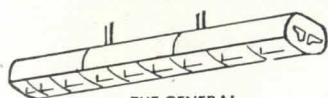

THE GENERAL

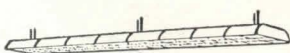

THE GRENADIER



THE COMMODORE

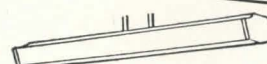

THE DIPLOMAT

**Why the STAR provides "skies" of eye-easy light**

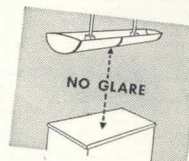

1. Low brightness . . . a maximum of .3 candles per square inch according to ETL test. Means no glare or reflected glare.

2. Blends into ceiling . . . means no distracting dark or bright patterns overhead . . . greater eye comfort.

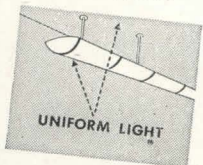

NO SHADOWS



3. No shadows on work . . . because "ceiling of light" means large area source with light over all . . . and thus . . . Over-ALL Lighting!

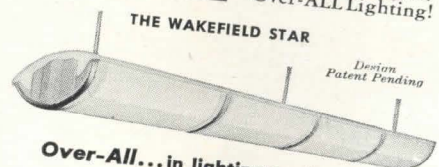

Over-All . . . in lighting performance in sturdy construction in ease of maintenance



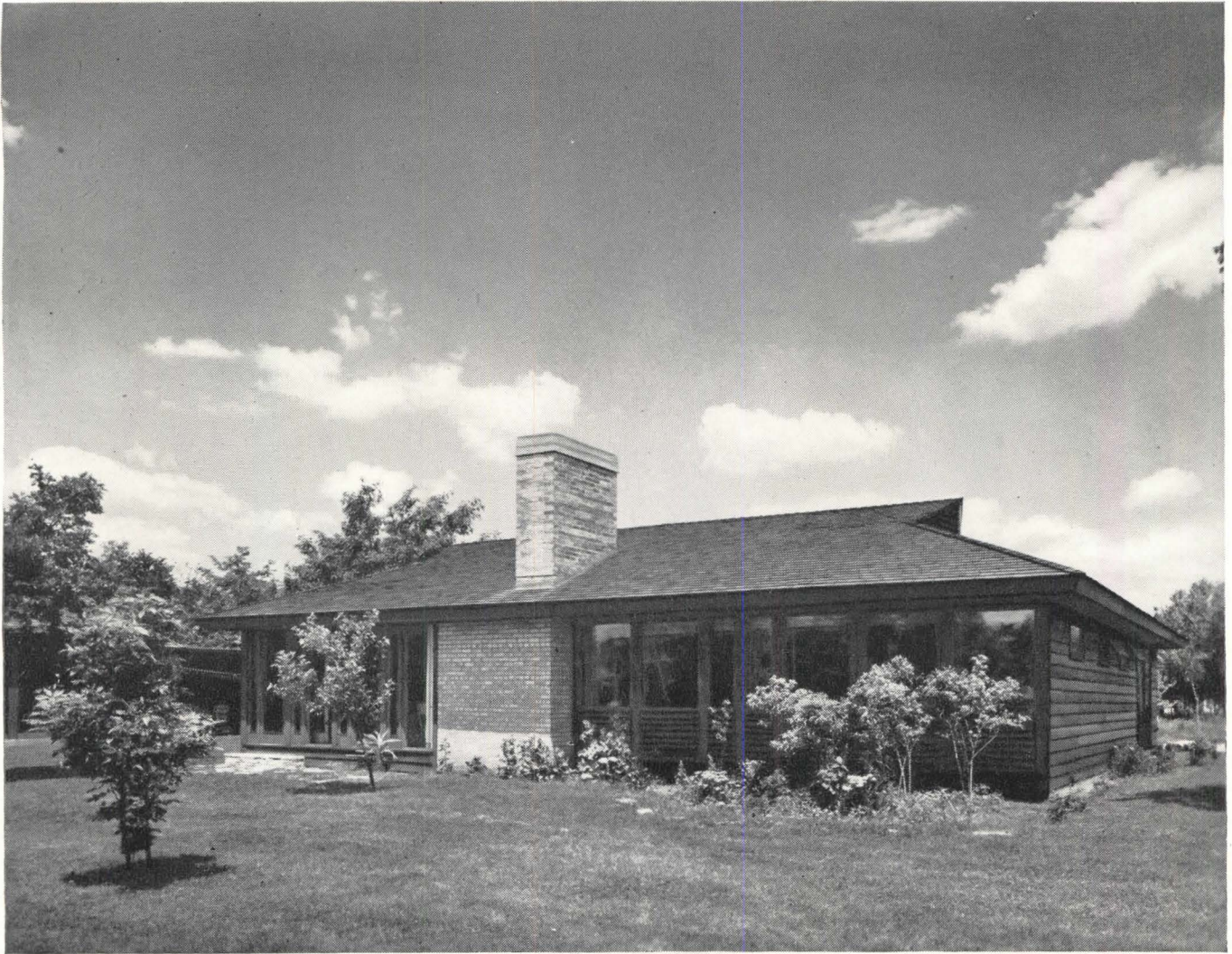

*Schweikher and Elting, Architects*

## SMALL HOMES, TOO, NEED RACEWAYS FOR TELEPHONE WIRES

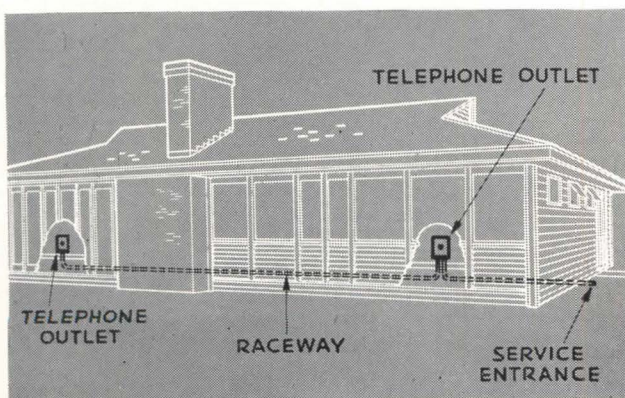

When you pack a lot of livability into a small space, little things mean much in comfort and convenience. A raceway for concealing telephone wires is especially important.

During construction of a one-story home without a basement, for example, the builder can generally assure a good telephone arrangement by (1) providing an entrance raceway for telephone wires; and (2) running a raceway under the floor to convenient telephone outlets. If there is to be an unfinished basement, all that may be needed is the entrance raceway, plus short raceways up within the walls to telephone outlet locations.

Your Bell Telephone Company will be glad to help you plan economical telephone wiring facilities in small homes or large. Call your Telephone Business Office and ask for "Architects and Builders Service."

**BELL TELEPHONE SYSTEM**





Look closely for Two specifications in one

## Q-FLOOR

Q-Floors require no revision of drawings—no matter how many changes of electrical outlet location are called for after construction begins. Q-Floors also save drawing revisions for support locations of mechanical equipment, which is suspended anywhere from steel Q-Floors, without prelocating inserts.

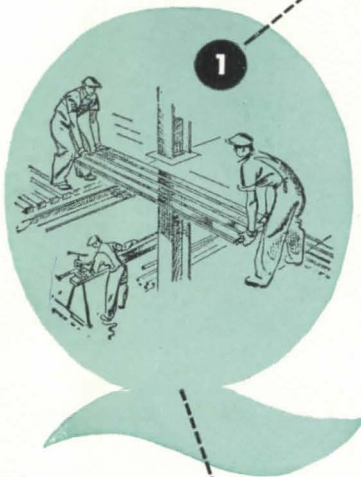
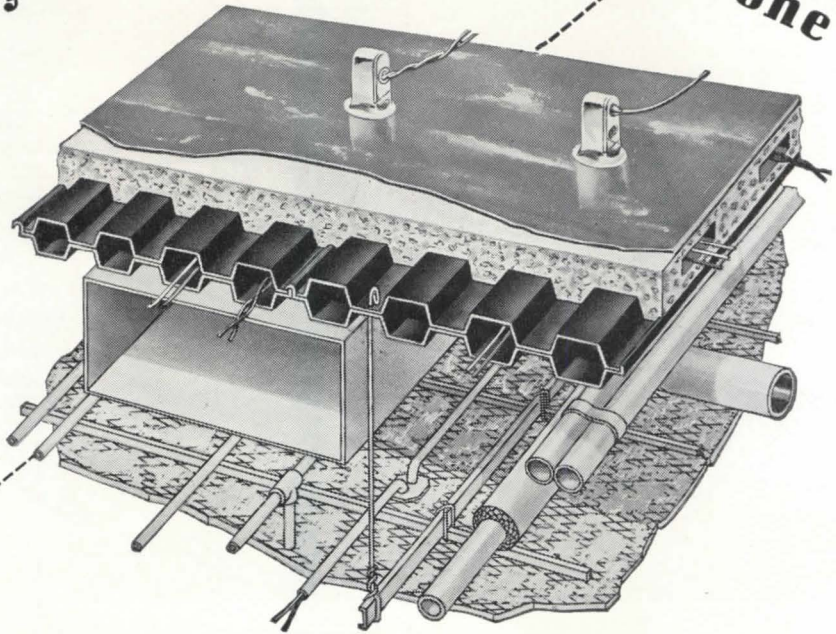

### FOR REDUCED CONSTRUCTION TIME

Steel Q-Floors come to the job cut to fit and go in so fast that floors are up about as soon as the steel framework to which they are welded. Two men can lay 32 sq. ft. in 30 seconds. The Q-Floor becomes a dry, noncombustible, safe working platform for all other trades. Over-all result is to reduce building time 20 to 30%. This effects savings from the start for client as well as designer.

Lightweight steel Q-Floors make possible additional floors where heavier construction is not feasible. Complete with suspended ceiling, the total dead weight is less than forty pounds per sq. ft., despite a four hour fire rating.



### FOR QUICK ELECTRICAL CHANGE

Every six-inch area of the exposed floor can be tapped for electricity. This feature permits permanently flexible floor plans and, therefore, guards the entire building against electrical obsolescence. It's a god-send to both owner and architect, for partitions and outlets can be rearranged as often as desired, with no debris, electrical fuss or muss. The cells of the floor are crossed over by headers in such a way that an electrician can fish wires to any spot. A new floor outlet takes literally a few minutes—and no trenches. Just a small hole drilled. Q-Floor Fittings can be seen at any General Electric construction materials distributor's.

The price is right. And there are thousands of installations all over the country in all types of buildings from garages to skyscrapers. Your Robertson representative will be glad to give detailed information and advise on delivery dates. For literature, please write

## H. H. ROBERTSON CO.

2404 Farmers Bank Building  
Pittsburgh 22, Pennsylvania



Offices in 50 Principal Cities  
World-Wide Building Service

THE EASIEST THING FOR A BUILDER TO FORGET—*Floors are what a building is for*



**Kawneer presents**

# Zourite

**A NEW ALUMINUM  
FACING MATERIAL**

- Handsome appearance
- Easy to install
- Easy to maintain



This modern shopping center in Modesto, California, makes use of Zourite as a facing for the walls which separate the stores and as a decorative covering for the cornice.

On Dean's Drug Store in Niles, Michigan, Zourite has been applied vertically to the exterior wall and horizontally to the sign area above the projecting ceiling ledge.







**BEFORE**

These "Before" and "After" pictures of Smith's Store in Oakland, California, show how successfully Zourite can transform an out-of-date building into a striking, modern store. No major alterations were made to the face of the structure.



**AFTER**

## **ZOURITE — THE MODERN FACING MATERIAL FOR FACADES, WALLS, CEILINGS, TRIM, AND OTHER EXTERIOR AND INTERIOR SURFACES**

Zourite is ideal for all facing jobs . . . for new construction or remodeling . . . for all types of commercial buildings.

Made of easy-to-work aluminum with a soft, semi-lustrous finish, Zourite is styled to the highest standards of contemporary architecture. Its decorative, cleanlined pattern and moderate price make Zourite a handsome and practical covering for the largest facade surface or the smallest area of trim.

It can be applied to exterior or interior surfaces without major structural changes. High costs for demolition work and alterations are eliminated.

Shipped complete with furring strips, fastening clips\*, and trim mouldings, Zourite can be applied horizontally or vertically to masonry, wood, or metal surfaces. Adjustable tongue and groove joints\* reduce job-site labor and eliminate the special manufacture of odd sizes and

\*Patent applied for.

shapes to meet individual job requirements. They also allow for expansion and contraction.

Easily maintained, Zourite can't chip, rust, or scale. It is washed clean with water, and it requires no painting.

Zourite comes in 8½-in. and 4¼-in. widths and 20-foot lengths which can be quickly cut to desired lengths on the job.

Write for construction details which will be sent to you at once, and for the illustrated Zourite book which will be off the press soon.

The Kawneer Company, 762 North Front St., Niles, Mich.

**Kawneer**  
SALES-BUILDING  
**STORE-FRONTS**



# OTIS POW-R-TRUCK ELEVATORS



## ADD THE "THIRD DIMENSION" TO POWER TRUCK TRANSPORTATION

Otis **POW-R-TRUCK** elevators add *up-and-down* travel to the many other advantages of power truck-loading!

With a **POW-R-TRUCK** elevator, industrial trucks become completely mobile units—free to go to upper or lower floors — free to take loads directly to destination. With a **POW-R-TRUCK** elevator you lose no time in loading, picking up or re-handling.

**POW-R-TRUCK** elevators are the world's only standard line of elevators built to:

1. Withstand severest off-balance loading and impact loading.
2. Carry both truck and pay-load safely and swiftly.
3. Suit every size, speed and capacity need.

You get *all* the advantages of power truck and unit-loading, when your trucks can travel vertically as well as horizontally.

**POW-R-TRUCK** elevators, standardized and made exclusively by Otis, are only slightly higher in cost than conventional freight elevators.

For illustrated folder please write Otis Elevator Company, 260 Eleventh Avenue, New York 1, New York, or call your local Otis office.



**ELEVATOR  
COMPANY**

OFFICES IN  
ALL PRINCIPAL CITIES



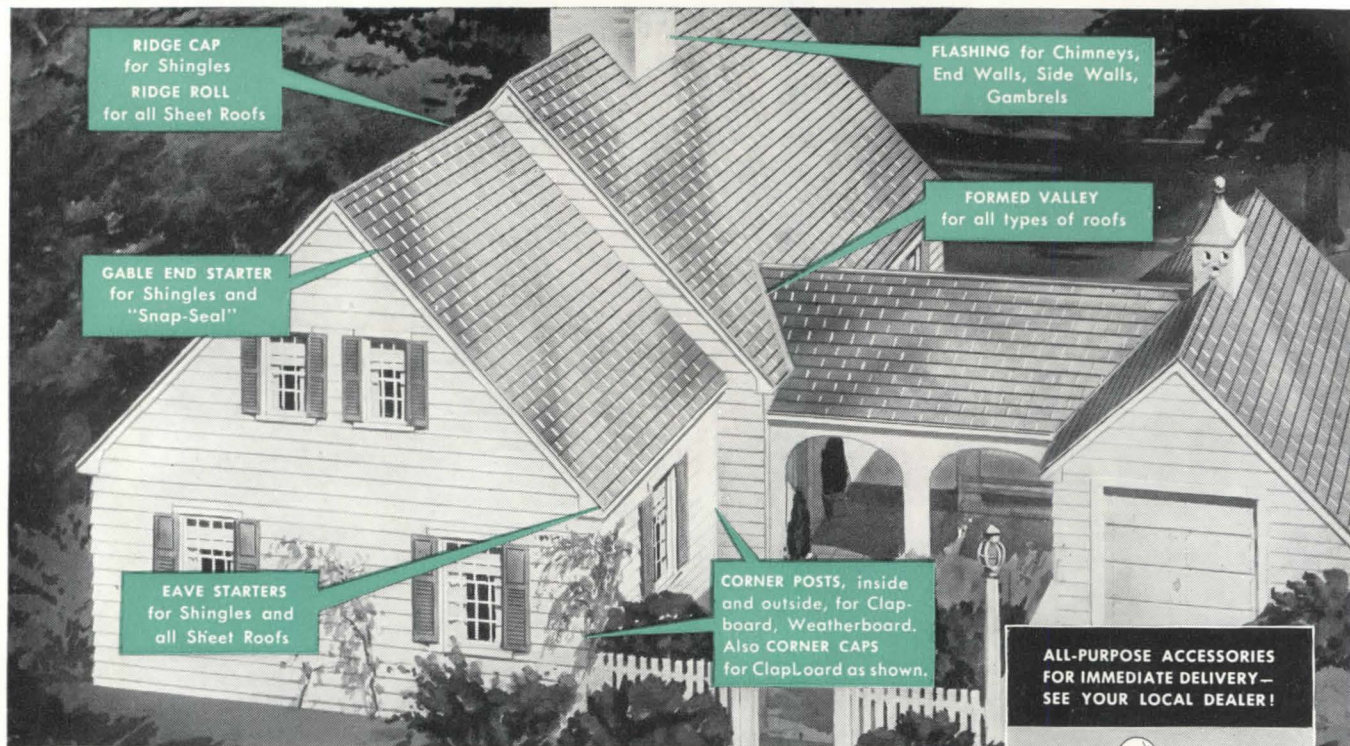

# Accessories

## to make aluminum roofs Perfect and other roofs Better

Soundly engineered accessories like these are an *extra* reason why more and more architects will specify Reynolds Lifetime Aluminum Shingles or "Snap-Seal" Roofing for fine homes . . . and Reynolds Lifetime Aluminum 5-V Crimp, Corrugated and Weatherboard for every type of farm, commercial and industrial building.

They are an extra reason why builders like Reynolds Lifetime Aluminum, too . . . the right accessories solve application problems, reduce labor costs.

But besides their use with aluminum, these accessories can meet an urgent need of architects and builders in other types of roofing—wood, slate or composition. They are light weight, easy to handle,

handsome and good for a lifetime of service.

So by all means specify Reynolds Lifetime Aluminum for complete roofing and siding. But where other materials are indicated, take advantage of these accessories. Remember, they are immediately available, in any quantity—together with the *right* nails. See Sweets or write for literature . . . offices in principal cities . . . Reynolds Metals Company, Building Products Division, Louisville 1, Ky.



*For 100% performance, use only the nails recommended by the manufacturer.*

# REYNOLDS *Lifetime* ALUMINUM BUILDING PRODUCTS

ALUMINUM SHINGLES-CLAPBOARD SIDING-SHEET ROOFING & SIDING-STUDS-TRUSSES-WINDOWS-GARAGE DOORS-REFLECTIVE INSULATION-UTILITY BLDGS.-HOUSES

TODAY THE BASE PRICE OF ALUMINUM IS 30% LOWER THAN PREWAR

ALL-PURPOSE ACCESSORIES FOR IMMEDIATE DELIVERY—SEE YOUR LOCAL DEALER!

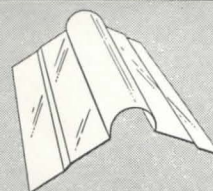

9 1/2" PLAIN RIDGE ROLL  
Made of .024" sheet, 10-ft. lengths, packed 10 to a bundle.

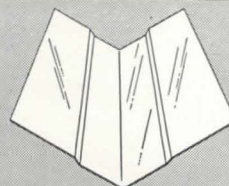

14" FORMED VALLEY  
Made of .024" sheet, 10-ft. lengths, packed 10 to a bundle.

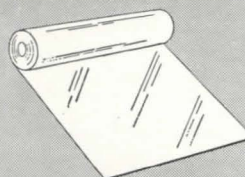

ROLL FLASHING—ROLL VALLEY  
18" wide, of .020" sheet, (Roll Valley .027" sheet) supplied in 100-ft. coils.

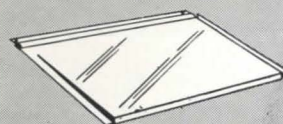

SHINGLES  
Interlocking, weather tight, covering all nails. Two sizes: 8 x 14 1/2 and 5 1/2 x 18 1/2.



# ACCEPTING THE CHALLENGE



*Architect: Mortimer J. Murphy, Buffalo.  
General Contractors: Balling Bros. &  
Holler Bros., Tonawanda, N. Y.*

Mercy Hospital, Buffalo, is accepting the challenge of the times for increased hospital facilities by adding three wings, two of 7 stories and one of 8 stories, to the existing 8-story brick structure. Spacious and attractive, the new wings will be equipped with the latest facilities for the treatment of patients.

Like hundreds of other structures now being built throughout the nation, this hospital addition will have a framework built of Bethlehem Structural Shapes.

**BETHLEHEM STEEL COMPANY, BETHLEHEM, PA.**

*On the Pacific Coast Bethlehem products are sold by Bethlehem Pacific Coast Steel Corporation*

*Bethlehem*

**STRUCTURAL  
SHAPES**





# King John to John King ...

*An idea borrowed from feudal times*

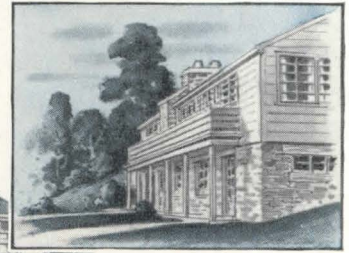
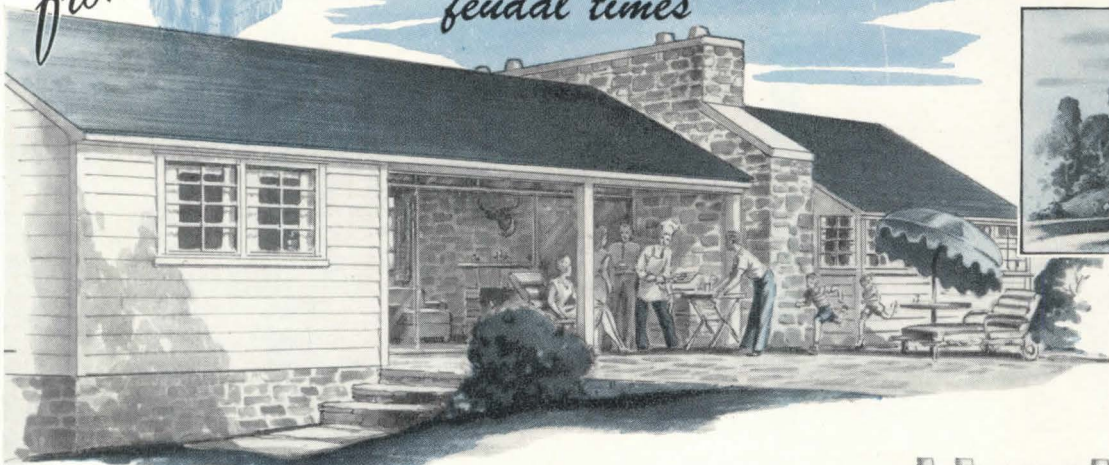

Front view, showing house — wide balcony and grade level basement entrance.



A house fit for a king. Barbecue oven reminiscent of the great fireplaces where spitted fowl and venison once turned before banqueting knights. Open slide doors and the living room porch, a single spacious room with massive floor-to-ceiling stone wall, exposed Gothic style trusses and a vast fireplace for stag's antlers.

Other features that will endear this house to "John Kings" include a second floor balcony running the length of the house, and an arrangement combining ground floor convenience at the back of the house with second-floor privacy at the front — all presented in the smart, modern manner.

And the smartest of all features is the design for coal heat — for which King John would have given a king's ransom.

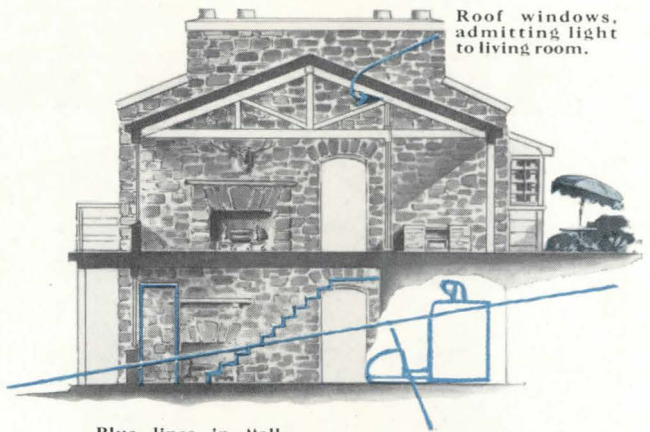

Roof windows, admitting light to living room.

Blue lines in "all-purpose room" show location of stair and hall door at opposite end of room.

Natural slope 1/6 — steeper if desired.

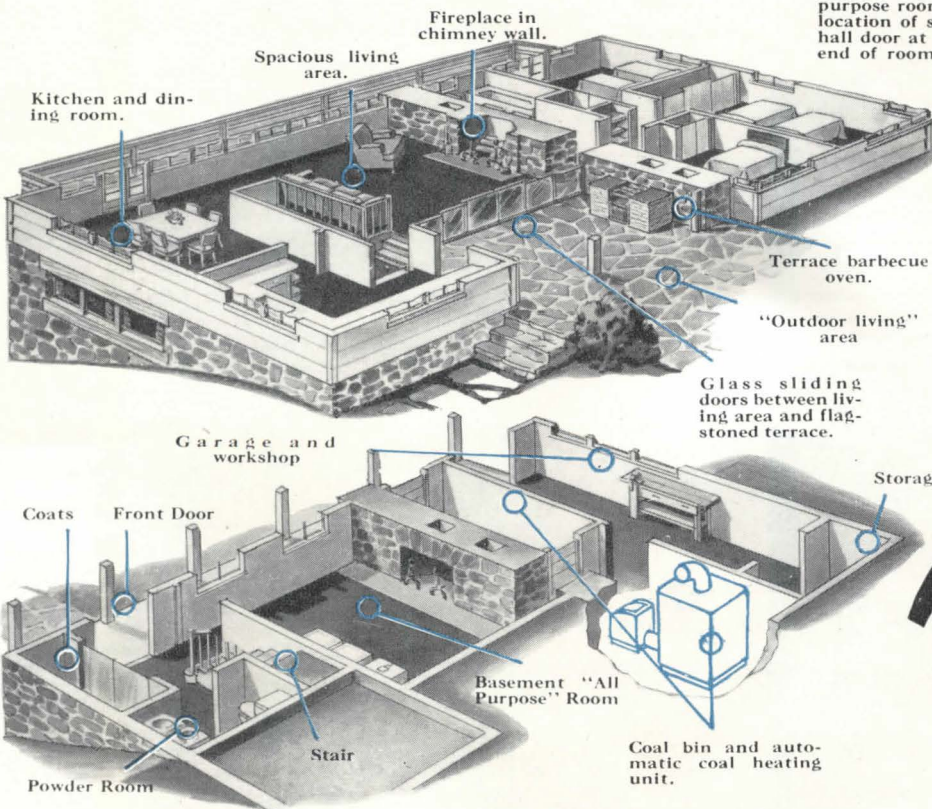

The choice of the millions of smart Americans who heat with coal is *Fuel Satisfaction* — the superior, all-purpose *bituminous* coal mined along the Norfolk and Western. Fuel Satisfaction gives even, healthful heat . . . clean heat . . . economical heat — and will still be keeping home fires burning when other fuels are exhausted.

**Norfolk and Western**  
**RAILWAY**

CARRIER OF FUEL SATISFACTION





78-bed general hospital at Alpena, Mich., is architectural concrete. Re-use of forms permitted economical repetition of ornamental details. Joseph C. Goddeyne, architect, Bay City, Mich. Owens-Ames-Kimball Co., Grand Rapids, contractors.

# ARCHITECTURAL CONCRETE *for* HOSPITALS



Piedmont Sanatorium, Burkeville, Va., is one of several concrete hospitals designed by Williams, Coile and Pipino, Newport News, Va., John T. Wilson Co., Richmond, Contractor.

Dormitory No. 10, one of newest of 35 architectural concrete buildings at Texas Tuberculosis Sanatorium, near San Angelo. Smooth walls formed against plywood are finished with white portland cement paint. Leonard Mauldin, architect, and Templeton & Cannon, contractors, both of San Angelo.

enables architects to stay within limited budgets; design attractive, firesafe, rugged buildings; insure low maintenance expense and low annual cost.

Literature on most recent design and construction practice for architectural concrete mailed free in United States and Canada. See our catalog in Sweet's.

## PORTLAND CEMENT ASSOCIATION

Dept. A8-8, 33 W. Grand Ave., Chicago 10, Illinois

A national organization to improve and extend the uses of concrete . . . through scientific research and engineering field work





FOR NO REGRETS, HEAR THE WURLITZER ORGAN FIRST!



## A FITTING VOICE... *for Divine Worship*

● The Wurlitzer Organ Series 20 is truly a church organ. To the church or church committee contemplating the purchase of an organ, this furnishes food for serious thought. For the Wurlitzer Organ draws its wide variety of stops from the four traditional tone families of the true organ, the distinctive diapason, the warm and mellow flute, the brilliant strings, and the plaintive reed. On the Wurlitzer Organ, organ music is played as written. No special scorings are required. Thus you achieve the true majesty of the music as originally scored by world-famous composers.

All this, plus amazing economy of space and cost, is yours because the Wurlitzer Organ utilizes sound electronic principles. Before you buy . . . for no regrets . . . see and hear the classically beautiful Wurlitzer Organ first. For further details and the name of your nearest dealer, write Dept. AR-8, Organ Division, The Rudolph Wurlitzer Company, North Tonawanda, N. Y.

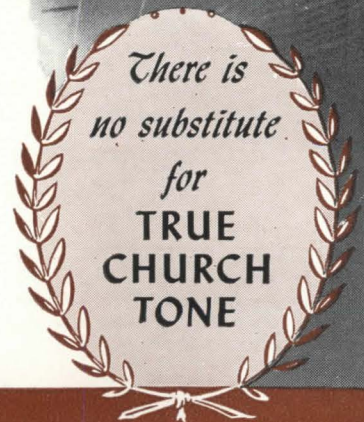

*The* WURLITZER ORGAN Series 20—Two-Manual



Now we can

# MEET THE HUGE DEMAND

for

# FINE WELDWOOD HARDWOOD PLYWOODS

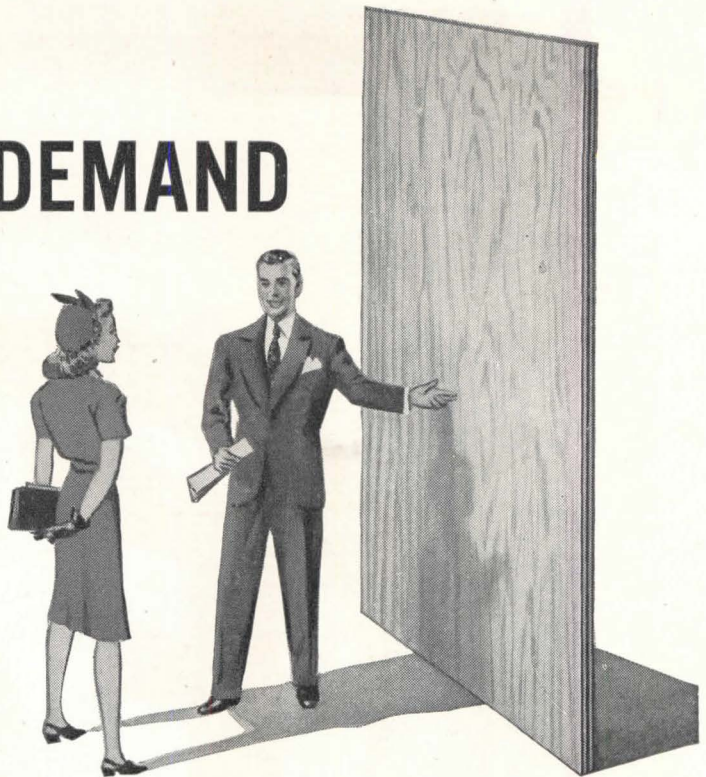

*For the first time since before the war, Weldwood Plywood is available in large supply . . . in a wide variety of fine cabinet hardwoods!*

And you'll find eager acceptance for Weldwood all through your clientele.

Why? Because . . . even in the face of serious shortages . . . we've carried on a vigorous national advertising campaign to sell Weldwood to home-minded Americans. As a direct result of this advertising, almost half-a-million prospective users have written for more complete information.

We've told them all the entire Weldwood story. They know, for instance, that Weldwood has striking decorative beauty plus high structural

strength. They know, too, that Weldwood can be installed easily and economically . . . either for remodeling or new construction.

And your clients know this: Weldwood's first cost is the last. It's guaranteed against splitting, cracking or warping for the life of the building in which it's installed.

Take advantage of this knowledge . . . and the acceptance that comes with it. Specify Weldwood. It's a modern material of *proved* quality and demand.

You can get detailed information on the wide variety of sizes and veneers now available from your nearest USP office or representative.

## WELDWOOD Plywood

*Weldwood Plywood and Mengel Flush Doors are products of*

UNITED STATES PLYWOOD CORPORATION  
New York 18, N. Y.

THE MENGEL COMPANY  
Louisville 1, Ky.

*Distributing units in Baltimore, Boston, Brooklyn, Chicago, Cincinnati, Cleveland, Detroit, Fresno, High Point, Los Angeles, Newark, New York, Oakland, Philadelphia, Pittsburgh, Rochester, San Francisco, Seattle. Also U.S.-Mengel Plywoods, Inc. distributing units in Atlanta, Dallas, Jacksonville, Louisville, New Orleans, Houston, St. Louis. In Canada: United States Plywood of Canada, Limited, Toronto. Send inquiries to nearest point.*

Weldwood\* Hardwood Plywood  
Douglas Fir Weldwood  
Mengel Flush Doors  
Douglas Fir Doors  
Overhead Garage Doors  
Molded Plywood  
Armorply\* (metal-faced plywood)

Tekwood\* (paper-faced plywood)  
Flexmet\*  
Weldwood Glue\* and other adhesives  
Weldtrex\* (striated plywood)  
Decorative Micarta  
Flexwood\*  
Flexglass\*  
Firzite

\*Reg. U.S. Pat. Off.



Plastics and Wood  
Welded for Good

*Waterproof Weldwood for exterior use is bonded with phenol formaldehyde synthetic resin. Other types of water-resistant Weldwood for interior applications are manufactured with extended urea resins and other approved bonding agents.*



# POWER

**for the Wheels of  
Industry with...**

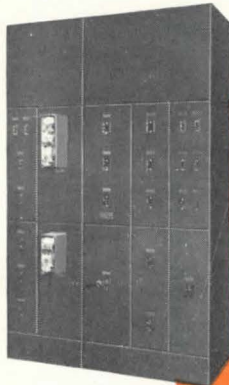

## CIRCUIT BREAKER

A safety type switchboard offering the latest developments in *automatic* protection of main and branch feeder circuits. Available in capacities up to 600 amps., 250 volts AC or DC; and 600 volts AC, 2 or 3 poles.



## KLAMPSWITCHFUZ

This safety type switchboard combines both disconnect switch and fuse protection in one unit. On switches of 200 amps. and less, heavily silvered copper contacts are "squeezed" together in one locking motion that clamps fuses at the same time; switches 400 amps. and up have Kamklamp Fuseholders. Capacities: 30 to 1200 amps., 250 volts, AC or DC; and 30 to 600 amps., 600 volts AC, 2, 3 and 4 poles.



## SWITCHBOARDS

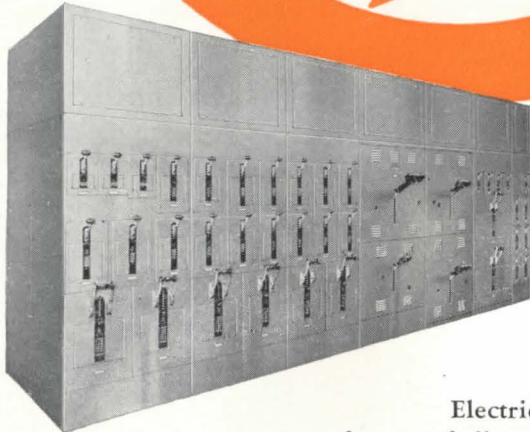

## SHUTLBRAK

A heavy duty, safety type switchboard with quick make and break switches and Kamklamp Fuseholders. Interlocking cover permits access to fuse compartment only when switch is in "off" position. Capacities: 30 to 1200 amps., 250 volts, AC or DC; and 600 volts AC, 2, 3 and 4 poles.

For more than 50 years the Frank Adam Electric Company has specialized in the design and manufacture of all types of switchboards for industrial, institutional and commercial purposes.

These switchboards are constructed from standard pre-assembled units for ease and economy of installation yet are tailored to fit your exact requirements. See your nearest  Representative for details.



# Frank Adam Electric Co.

ST. LOUIS 13, MISSOURI

Makers of BUSDUCT • PANELBOARDS • SWITCHBOARDS • SERVICE  
EQUIPMENT • SAFETY SWITCHES • LOAD CENTERS • QUIKHETER



# PORCELAIN ENAMEL.

As a medium for interesting, attractive effects, modern Architectural Porcelain Enamel is one of your most useful materials. You can use it for a great variety of applications.

## Colorful, Durable

There is no limit to the colors that can be obtained in Porcelain Enamel. Sparkling white, gleaming black and any color—rich hues or delicate pastels—can be obtained in glossy or matte finishes. Porcelain Enamel does not fade or lose its colorful beauty—it truly is the "lifetime finish." Being rugged and easily cleaned, Porcelain Enamel is a good investment.

## Any Type of Work

You will find Porcelain Enamel useful for new construction or for remodeling. It can

be used for large areas or small details for exteriors or interiors, for attention-arresting design or quiet dignity.

## Your Ideas Accurately Developed

Being versatile, Architectural Porcelain Enamel enables you to secure, in the finished structure, the design and colors you visualize in your plans. You have considerable freedom in your planning, and can get the effects you want.

## Use With Confidence

You can have complete confidence in the quality and durability of Porcelain Enamel, when made to meet the standards and specifications of the Architectural Division of the Porcelain Enamel Institute.

## ● This New Booklet

will help you use Architectural Porcelain Enamel economically and to best advantage.

Its many illustrations, showing how this colorful modern material has been used effectively by leading architects for a variety of applications, will help stimulate your own design ideas.

*Get your copy now!*

Porcelain Enamel Institute, Inc.  
1010 Vermont Avenue, N.W.  
Washington 5, D.C.

Please send me a free copy of your new booklet "How Architectural Porcelain Enamel Produces Profits."

Firm Name \_\_\_\_\_

Address \_\_\_\_\_

City \_\_\_\_\_

*Just off the Press* →

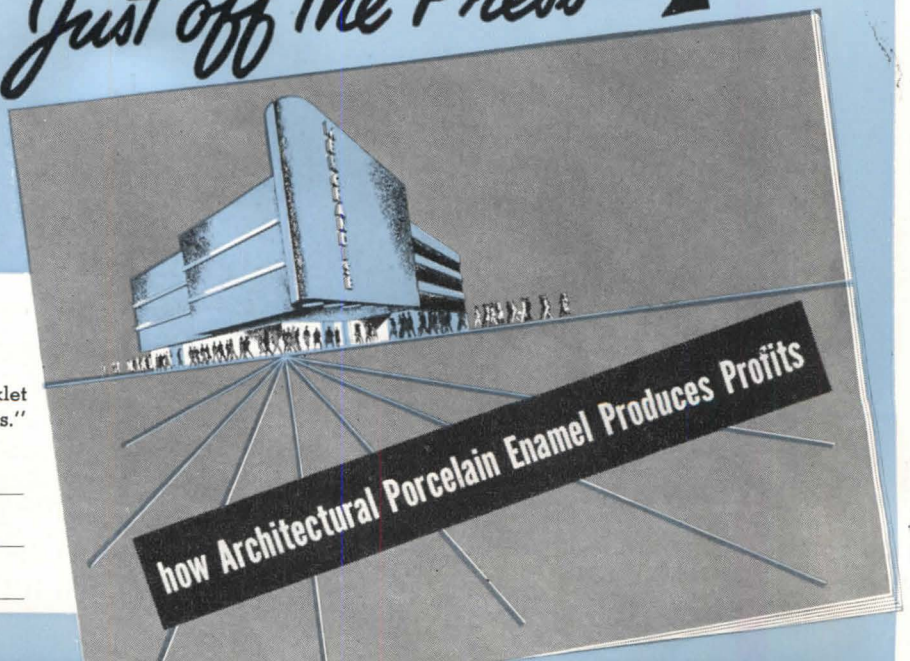



.. a versatile, effective

# *Architectural Material*

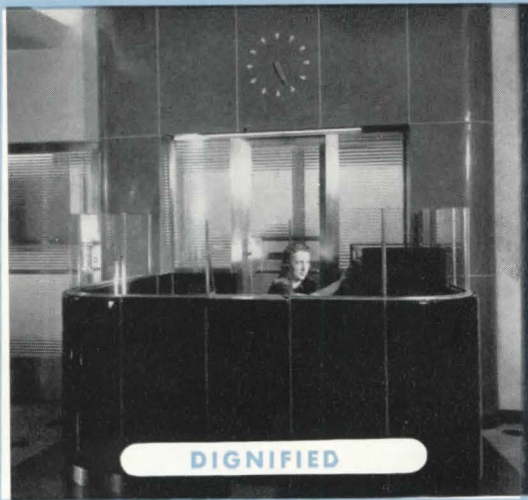

**DIGNIFIED**

Porcelain Enamel in rich colors or soft pastels makes for an effective, attractive reception room.

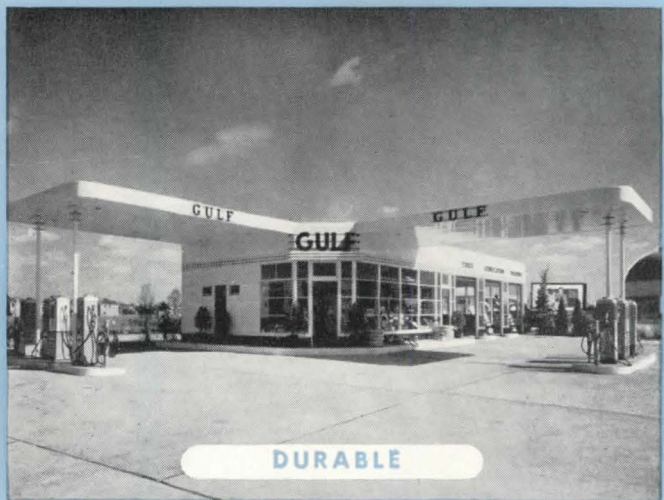

**DURABLE**

Where clean appearance must be maintained under hard service conditions, Porcelain Enamel does a good job.

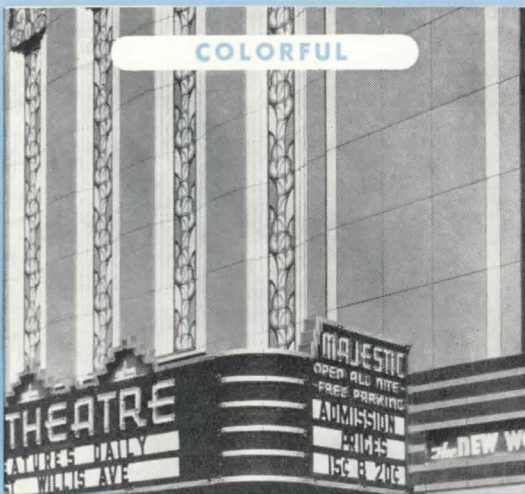

**COLORFUL**

When you want brilliant effects, Porcelain Enamel offers an unlimited range and combination of colors.

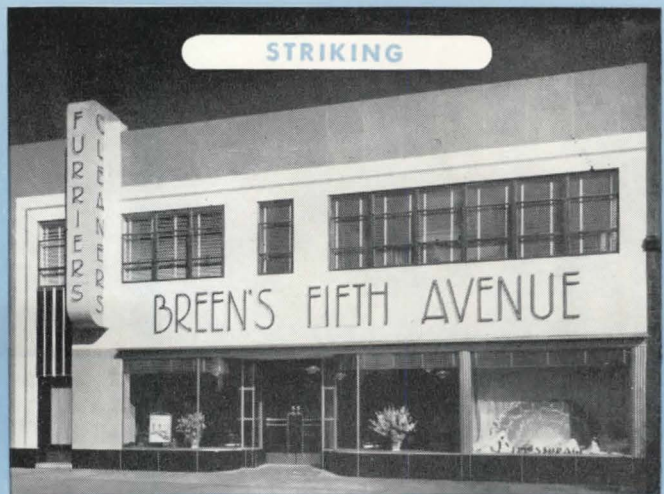

**STRIKING**

Smart, modern treatments developed in Porcelain Enamel are appropriate for many types of commercial establishments.

**PORCELAIN ENAMEL INSTITUTE, INC.**

1010 VERMONT AVENUE, N.W. • WASHINGTON 5, D.C.



**When day is done** ★ ★ ★

this door welcomes and protects your depositors



*The New* **Herring-Hall-Marvin**  
**CIRCULAR NIGHT DEPOSITORY**

Write, Wire or Telephone for Descriptive Literature

**HERRING-HALL-MARVIN SAFE CO.** *General Offices* HAMILTON, OHIO

Branch Offices: NEW YORK CITY • CHICAGO • WASHINGTON, D.C. • BOSTON • BUFFALO  
PITTSBURGH • DETROIT • ST. LOUIS • ATLANTA • HOUSTON • LOS ANGELES • TORONTO





THIS DEPARTMENT STORE  
STOPPED A *Thief!*

AND GAVE ITS CUSTOMERS  
CLEANER, MORE EVEN HEAT

*Central Heating*

MADE IT POSSIBLE!

**BEFORE...** An out-grown power plant occupied valuable space, produced smoke and dirt right at the store site.

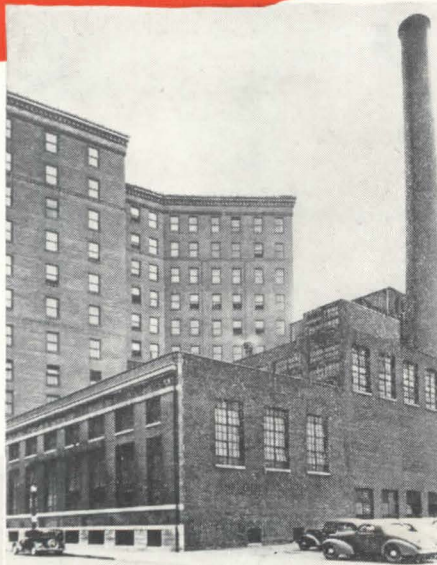

**AFTER...** Complete elimination of power plant frees space for efficient use, frees management of the smoke problem.



Smoke was stealing selling space from Sibley, Lindsay & Curr Company, of Rochester, N. Y. until this progressive institution began obtaining all power and steam from the central distribution system of the Rochester Gas & Electric Corp. Now it is a cleaner, lighter department store, now a new economy of space has been achieved.

When expansion proved too much for the store's own power plant, the changeover to central heating, made without interference to store operation, resulted in many advantages of interest to architects. Comparing favorably in dollar cost, purchased service eliminated a source of noise and dirt, freed valuable space for further use. To meet increased demands upon its system by other companies recognizing these benefits, the Rochester Gas & Electric Corporation has constructed a tie-line which provides the city's business district with 200,000 lbs. additional steam per hour. In this tie-line, as in hundreds of other major central heating systems, the steam travels underground through Ric-wil prefabricated insulated conduit, specified for economy, for thermal efficiency.

**RIC-WIL**

INSULATED PIPE CONDUIT SYSTEMS

THE RIC-WIL COMPANY - CLEVELAND, OHIO

CABLE ADDRESS: RICWIL, BENTLEY'S CODE



# How to Install *Thermopane*

REG. U.S. PAT. OFF.

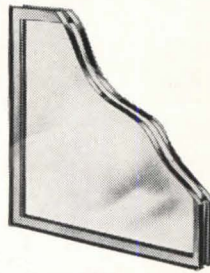

CUTAWAY VIEW OF  
THERMOPANE UNIT

Because *Thermopane* is being used more and more in buildings of all types, you will welcome this step-by-step explanation of *Thermopane* installation. It requires no special skills or special tools. For more complete glazing details than illustrated below, check your Sweet's File or write us.

## IN WOOD SASH



1. Be sure opening is square so unit will not bind. Bed sash with high-grade glazing compound free of corrosive agents before the *Thermopane* is inserted.

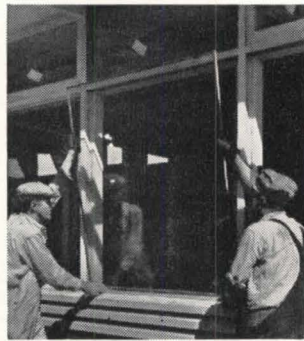

2. Place unit on approved setting blocks located in from each corner and centered  $\frac{1}{4}$  the length of the unit. Press in evenly. Allow equal clearance between edges of glass and sash.



3. Fill voids on all edges with glazing compound to prevent air infiltration and water leakage. Do not use blocks at sides or top of *Thermopane*.



4. Cover perimeter with glazing compound before applying face stops. To avoid point pressure, do not toenail unless sash is rabbeted to receive stop.

## IN STEEL SASH

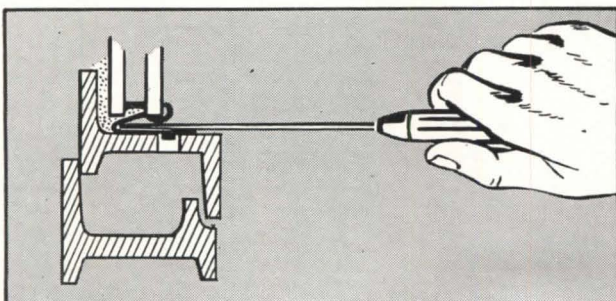

Specially-designed L·O·F phosphor bronze clips are now available from L·O·F Distributors for installation in steel sash.

1. Bed sash with glazing compound.
2. Insert *Thermopane* unit.
3. Put clip on end of putty knife.
4. Insert clip between edge of *Thermopane* unit and steel section until clip lug snaps into hole.
5. Fill all edge voids.
6. Face finish with glazing compound.

## STANDARD SIZES

*Thermopane* is made in more than 60 standard sizes, readily adaptable for new construction or remodeling—for Picture Windows, Window Walls, double hung wood window units and residential steel casements. Your L·O·F Distributor has most of the Picture Window standard sizes in stock. Libbey·Owens·Ford Glass Company, 2287 Nicholas Building, Toledo 3, O.



**LIBBEY·OWENS·FORD**

*a Great Name in* **GLASS**

ONLY L·O·F MAKES *Thermopane*





# CROWDS AREN'T CONSIDERATE!

IN SCHOOLS, STORES, STADIUMS . . . places where public use is both constant and careless . . . Richmond plumbing and heating equipment is providing long, trouble-free service. That's why it is safer to specify Richmond for institutional, industrial and commercial buildings.

Richmond products provide a greater return for your client because their installation costs are lower. Well-packaged, with clear, accurate instructions, they save installation time.

Richmond plumbing equipment is backed by the one-year guarantees recommended by the U. S. Bureau of Standards. Richmond gas-fired heating equipment has both AGA approval and a one-year replacement guarantee. For details, write Richmond Radiator Co., 19 East 47th Street, New York 17, N. Y.



Morley Vitreous China Lavatory G-135. An attractive lavatory slab for either centerset or combination supply fitting. Rectangular bowl, rear outlet, integral open overflow and anti-splash rim. Sizes: 20" x 10" and 24" x 20".

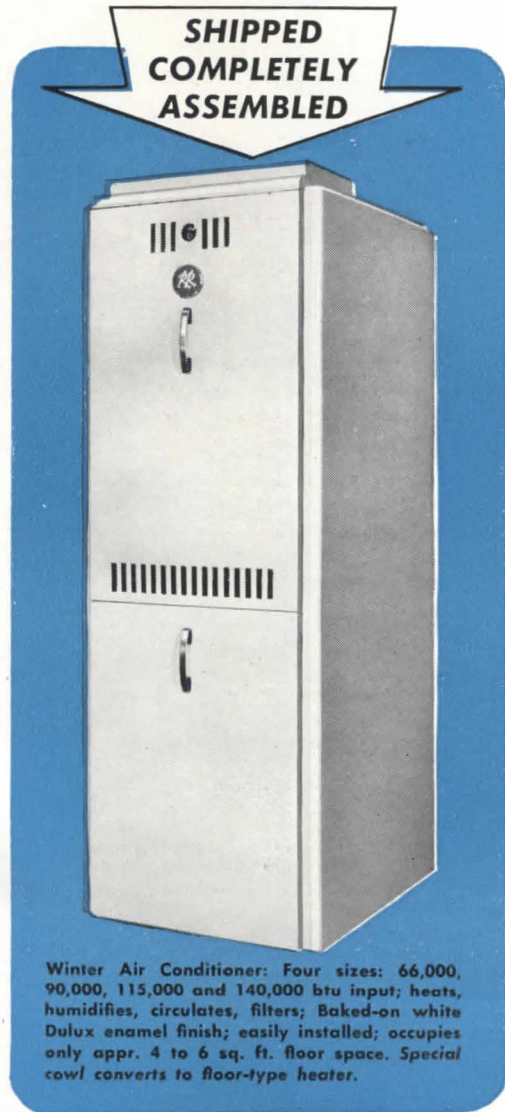

Winter Air Conditioner: Four sizes: 66,000, 90,000, 115,000 and 140,000 btu input; heats, humidifies, circulates, filters; Baked-on white Dulux enamel finish; easily installed; occupies only appr. 4 to 6 sq. ft. floor space. Special cowl converts to floor-type heater.

FACTORIES AT METUCHEN, N. J., MONACA, PA., NEW CASTLE, DEL., UNIONTOWN, PA. (2)



**RICHMOND RADIATOR COMPANY**  
Affiliate Reynolds Metals Co.

Enamelled Cast Iron Ware • Vitreous China • Perma-Gloss • Gas Boilers • Gas Winter Air Conditioners • Gas Gravity Furnaces • Radiators



# HONEYWELL CLOCK THERMOSTATS

.....are here again!

- NEW DESIGN
- NEW APPEARANCE
- NEW FEATURES
- NEW PERFORMANCE

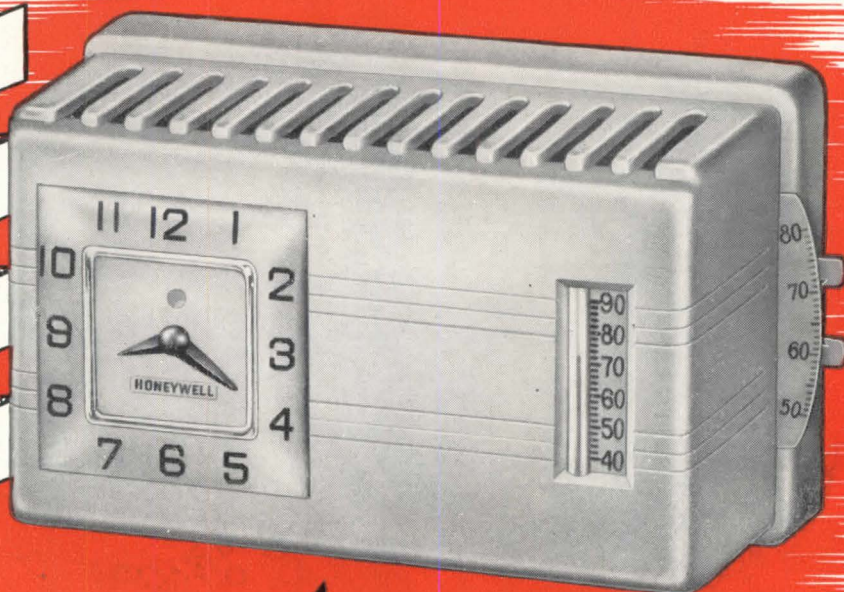

## THE NEW *Chronotherm*

### Check these ten outstanding DESIGN FEATURES

- 1 Simplicity of overall design. No troublesome intricate mechanisms. Exceptionally compact.
- 2 New bimetal element . . . assures more accurate temperature control, yet sturdy and dependable.
- 3 Fingertip external adjustment for day-night temperature settings.
- 4 Gradual morning pickup insures accurate temperature being restored to the daytime setting without overshooting.
- 5 Ease of time settings for day and night operation.
- 6 External fingertip wheel for setting clock . . . hands may be set as easily as a watch.
- 7 Low speed clock motor . . . the ultimate in quiet, accurate clock operation.
- 8 Clock motor provides 30 times more power than required.
- 9 Easily removable clock assures ready means of replacement.
- 10 Separable wall plate for easy mounting.

Here's *BIG* news and it's *opportune!*

Once again Honeywell leads the way—this time with the entirely new Chronotherm, the finest electric clock thermostat ever built.

Coming at this time in the face of a possible fuel shortage, the Chronotherm has special, added significance because it saves fuel. This feature alone creates an immediate demand. Your clients will be quick to appreciate the advantage of extended fuel supplies, lower heating costs.

You'll want to specify this control as a mark of the newest and most modern improvements in the homes you're designing. And don't overlook the Chronotherm as part of every home remodeling and modernizing project. When you explain how the new Chronotherm saves fuel by automatically lowering temperatures during the night and providing more accurate control at all times, it's a matter of timely interest to every home owner. And they'll recognize the advantages of increased comfort and convenience. Call the Honeywell branch in or near your city or write for complete information at once. Minneapolis-Honeywell, Minneapolis 8, Minnesota. In Canada: Toronto 12, Ontario.

DELIVERIES NOW BEING MADE TO YOUR SUPPLIERS

Order your  
**SALES and DISPLAY HELPS**  
Today!

MINNEAPOLIS  
**Honeywell**  
CONTROL SYSTEMS



## PLANNING, TOO, IS FOR PEOPLE

PERHAPS one of the most significant trends in architectural and city planning thought is the recognition of the needs and desires of *individuals* as well as groups, classes or masses of people. There is a return from grand concepts of city planning as pleasing linear plan patterns to a testing of those esthetic abstractions in terms of human reactions in use and in three dimensions. The imposed-from-above pattern, even when produced by thoughtful and competent planners, may be found lacking in its desired end result of contributing fully to the happiness and richness of life of the individual citizen. This has been brought out more and more forcefully by the writings of Churchill, Hudnut, Sert, Gideon, Burchard, Kump, and a host of others who are both objective and human in their approaches.

Then too, the tenor of the recent Princeton Conference and of the more recent Columbia Conference on city planning placed greater emphasis on the spiritual and esthetic needs of individuals than on the materialistic. The latter type of planning in its insistence on order, may become hard, mechanical, monotonous, drab regimentation if it leaves out (as it too often does) the opportunity for the spontaneous, the joyous, the accidental. Even though the plan may analyze scientifically and be functionally compartmentalized on statistics, and prove financially economic — it may leave out elements essentially human that contribute to the sense of healthy, happy well-being desired by the individual.

A case in point is the replanning of St. Dié (ARCHITECTURAL RECORD, October '46). One factor which the grand plan of Corbusier may have overlooked in proposing tall apartment houses is the intense, ingrained, traditional desire of the individual inhabitants to be close to the earth, to have their own gardens to tend and to view with pride and inner satisfaction from their windows.

In perusing the interesting and stimulating plans of the development of Zlin on the pages immediately following, it may be well to keep these factors in mind and to judge critically, weighing theoretical planning ideals against probable emotional and social reactions, orderly pattern against individual freedom, unity *vs.* variety. It may be that the human desires and satisfaction of the individual community dweller can be fulfilled and integrated in the plans, as well as the desires of the community planner for all-over orderly pattern. After all, planning is for people, and people are individual, and very human, beings whose thoughts and habits are as important as traffic surveys and land values.

*Kenneth K. Stowell*

EDITOR



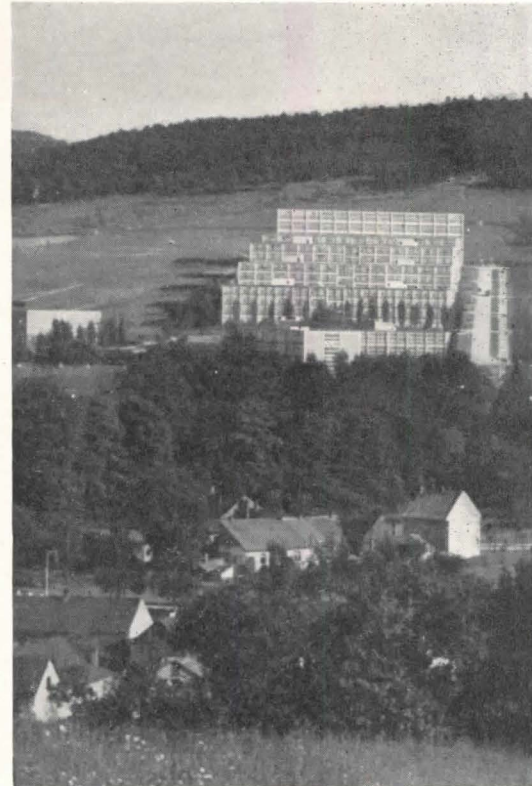

**FROM A QUIANT PROVINCIAL TOWN,  
ZLIN, CZECHOSLOVAKIA, DEVELOPED  
INTO A COMPLETELY INTEGRATED  
INDUSTRIAL CITY BECAUSE —**

**THEY**

*Zlin during the bombardment of factories, November, 1944*



**I**N THE HEART of Moravia, surrounded by hard-yielding farmland, where the back of the horse and the back of a man are still the prime sources of energy, and the common plow is the first tool, lies the city of Zlin. At its outskirts the rough country road turns into a concrete highway, over which one rolls into a lively twentieth century industrial city. Here is electric power, here are assembly lines turning out cheap shoes, here are prefabricated houses and multi-story buildings raised by efficient, standardized construction methods. Most exciting of all, here is modern graciousness and decency. Here is order. The green of surrounding hills reaches into the heart of the city. Meaningfully proportioned outdoor spaces heighten the feeling of integration between places of work, decent living quarters, and other components of community life. Here is the achievement of advanced methods of planning and construction applied to industrial plant and housing alike.

Until the turn of the century, Zlin was just another of the provincial towns in a poor hilly country. Its phenomenal development started when Thomas Bat'a, the "Czech Ford," foreseeing the market possibilities of



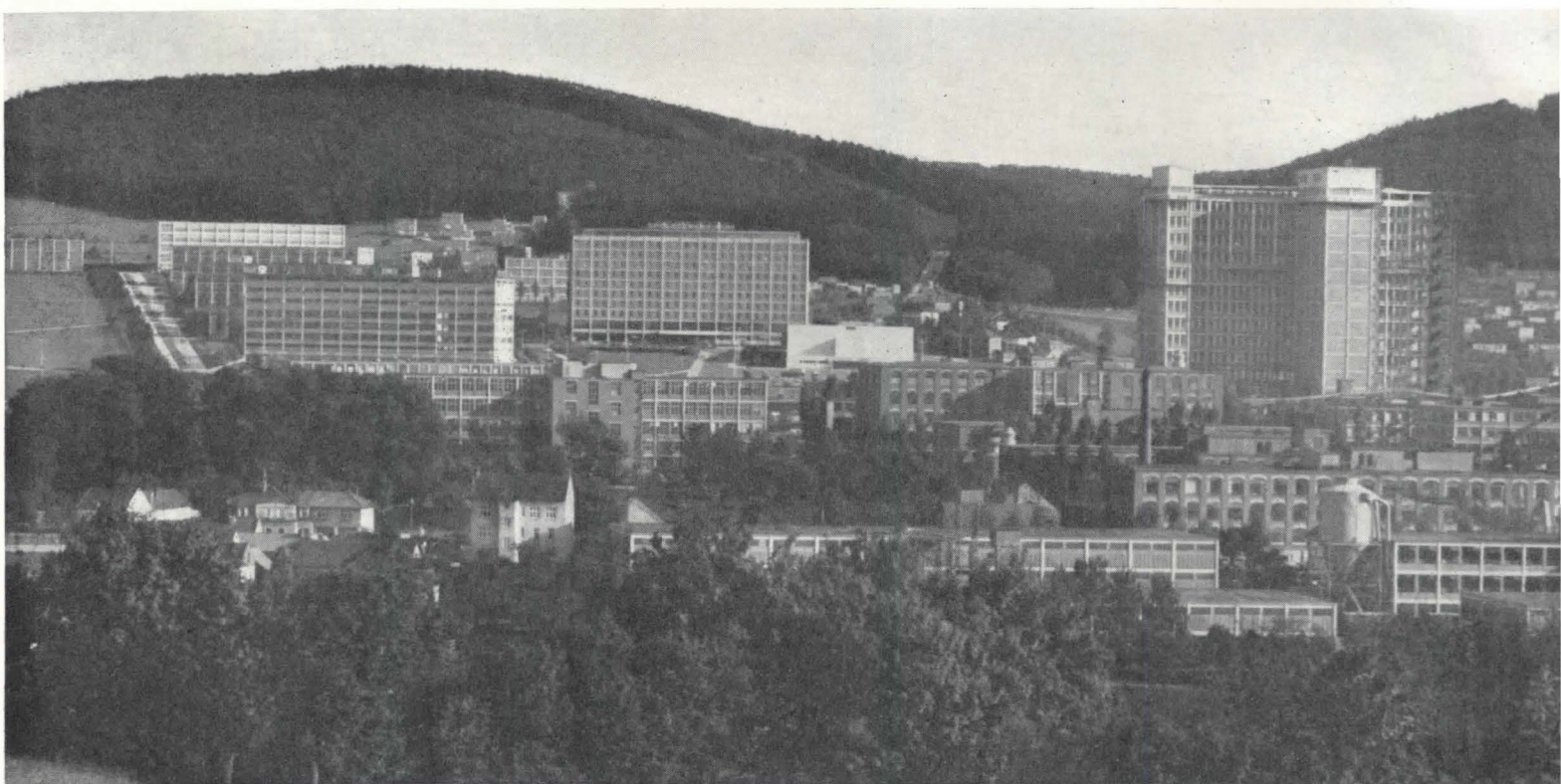

# PLANNED IT THAT WAY

By JAN POKORNY and ELIZABETH HIRD

a cheap shoe, began to modernize and expand his family's shoe workshop. By the time of the first World War the factory was employing 1500 and working to capacity. Turning war profits back into the industry, studying industrial methods, not only in middle Europe, but in America and England, Bat'a continued the rapid expansion of the firm, and by 1922, during the general depression, he was able to reduce the price of his shoes by half. Soon there was a Bat'a retail store in every hamlet in Czechoslovakia, and the firm's products began to penetrate abroad. The plant grew enormously. Auxiliary workshops were founded for the manufacture of shoe machinery, textiles, and chemicals, and a few years later the company branched out into the hosiery and rubber tire industries.

The increasing numbers of employees drawn to Zlin by the Bat'a Works necessitated an increase in all the facilities for living. As a step toward providing these, the company opened food industries and consumes, and by efficient management, lowered prices and increased the real wages of the workers.

To coordinate all necessary building, a sizeable

architectural and construction office was established, employing good architects, among them Gahura and Karfik, and other specialists. Housing for workers soon became part of this office's responsibility. Residential districts, dormitories, schools, recreational facilities, theaters, hotels, and department stores were built. These were all owned by the company, just as were the power plants and various means of transportation. The far-reaching company ownership, while making the worker dependent on the firm in many ways, had the advantage of making coordinated planning possible.

For Zlin's first new residential districts, Western garden cities in England and Holland provided the examples. Isolated one to four family units were placed in unsubdivided greenery. The design of the two-story brick houses was chiefly dictated by strictest economy of building. Considerations of economy also led to rather monotonous street patterns and little regard for orientation. But on the whole *this kind of housing* was a great improvement over the living standards of workers in middle Europe. Young people were housed in multi-storied dormitories near the new town center.



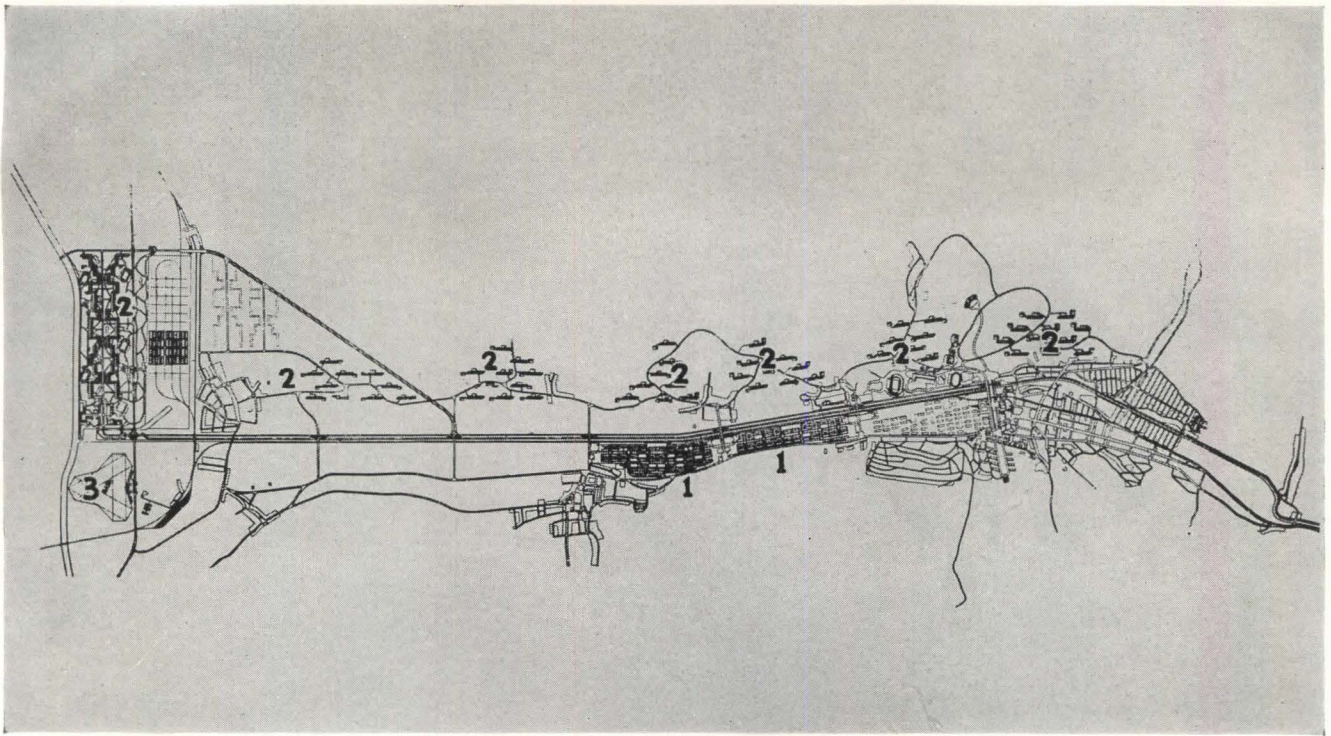

Le Corbusier's plan for Zlin and its extension along the valley. Numerals refer: 1, to extension of factories; 2, to additional residential apartments; 3, to a proposed airport. Compare with later plan, the enlarged section on the opposite page Below, diagrammatic plan showing a proposed pattern for an industrial center such as Zlin. J. Vozenilek, planner, 1941

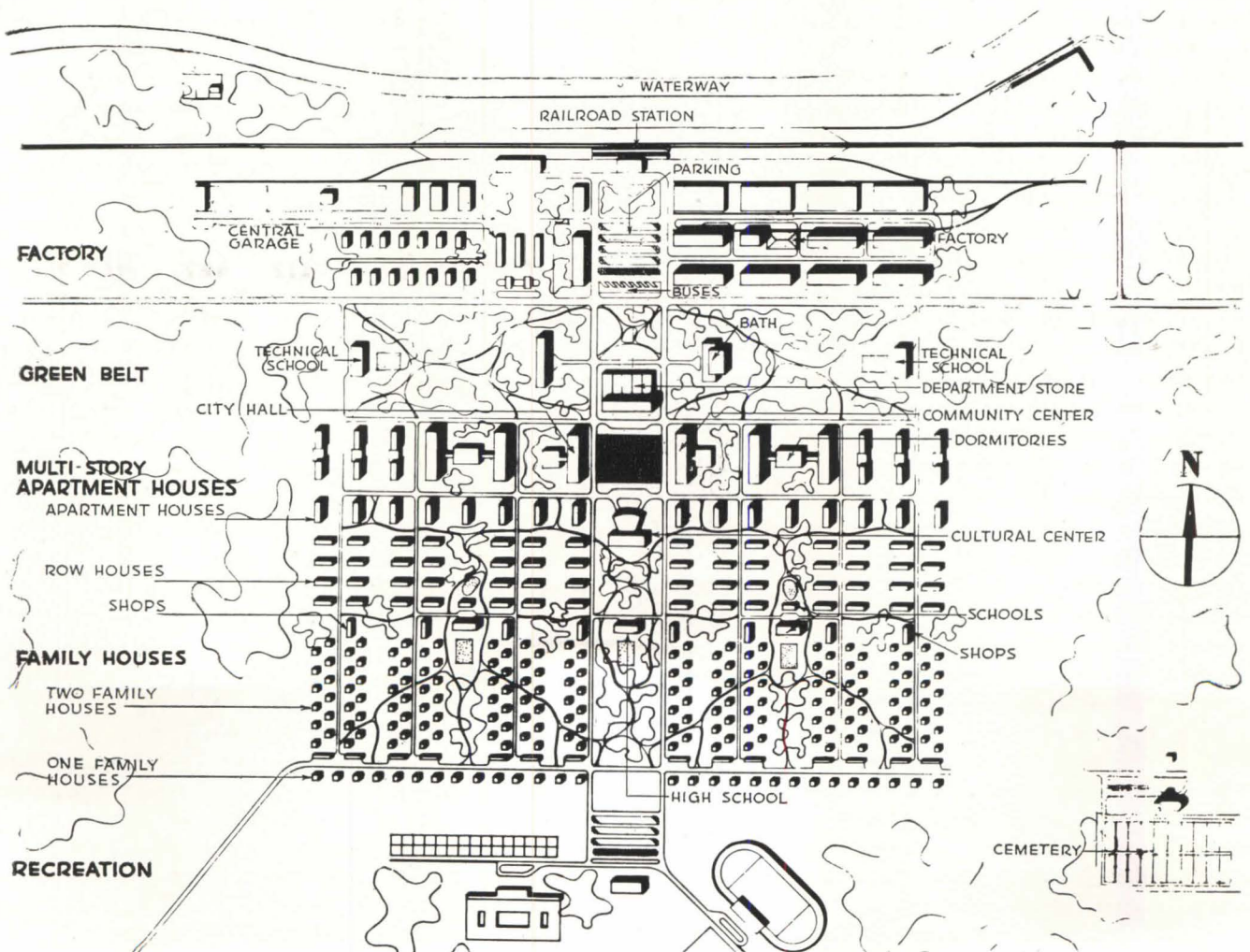



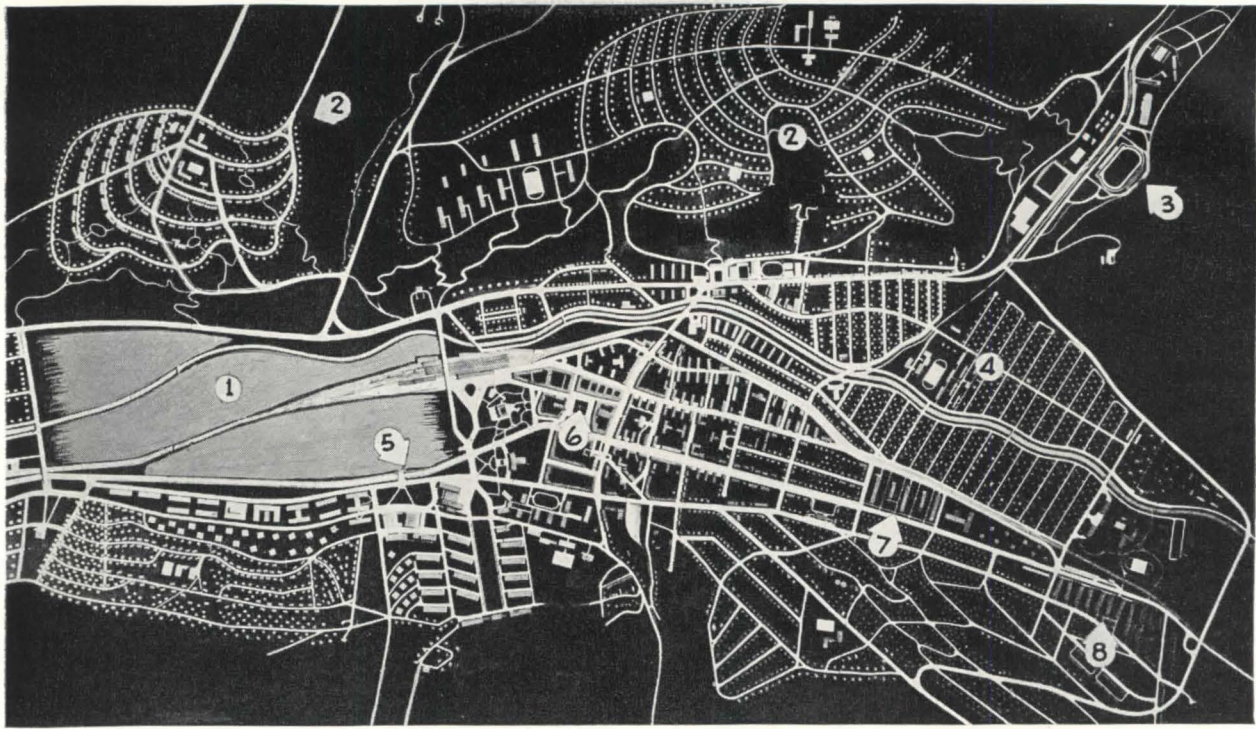

Master plan of Zlin, 1947, showing: 1, site of factory; 2, proposed residential sections; 3, new recreational area; 4, old residential section; 5, new town center; 6, old town center; 7, new multi-story apartment houses; 8, new three-story apartment houses. F. L. Gahura, V. Karfik, V. Kubecka, A. Vitek, J. Vozenilek, architects and planners

The rapid expansion of the industry continued even after Thomas Bat'a's death in 1932. The company was faced with the problem of enlarging not only the plant but the living facilities for the increasing population which the factory attracted to Zlin.

In 1935 Le Corbusier was engaged to prepare a design to solve this problem. Le Corbusier's plan designated slopes with the desirable southern exposure along the adjacent valley for the new residential sections. But at this time expansion in Zlin met with insurmountable difficulties. Land speculators demanded exorbitant prices for these very slopes. This obstruction, together with a shortage in water supply for the factories, prevented the company from further centralizing production in Zlin itself, and started the development of independent production units in various distant parts of Czechoslovakia. Similar units were being established abroad to overcome tariff barriers. These were all designed in Zlin, complete with housing, social, recreational, and cultural community facilities for workers.

The volume of work led the planning division of the Bat'a Works to systematic city planning studies. The principles, progressively evolved from these studies, had a very high standard, as is evident from the plans of some of the more recent industrial communities.

The residential sections are limited in size so that workers can reach their place of work comfortably by foot. If a greater number of workers is needed in a particular community, the percentage of apartment houses in relation to individual units and row houses is increased. Unmarried workers are housed in dormitories. The civic center is placed between these dormitories and the family residential area. Schools and small shopping elements are spotted throughout the community. A green belt separates the factories from

the residential neighborhoods. Recreational facilities are amply provided and located near continuous woodland or on a body of water. The sites of such industrial units are usually near main rail and highway arteries.

After the second World War, the nationalization of the big industries in Czechoslovakia and the new land-use legislation reopened the question of further developing Zlin itself. With the land needed for workers' housing made available, and a dam for industrial water supply projected nearby as part of the nation's two-year reconstruction plan, further expansion became feasible. A new regional plan was developed which provided for a partial reorganization of the industry. The planners, making use of the experience accumulated in designing such decentralized communities as we have described, located subsidiary industries, manufacturing half-products for the Zlin plant, along the short valley between Zlin and the city of Batov where another Bat'a factory already existed. The main and supplementary plants are to be connected along the short distances which separate them by railroad and highway.

This chain-like arrangement facilitates the distribution of the corresponding residential communities along the valley, maintaining the desired direct relationship between living quarters and places of work. Housing for the workers will be set on the generous and sunny hill slopes above the factories. Although each factory-home group is to have its own communal facilities, Zlin will serve as a unifying cultural and social center to the entire region, and the increased population will make possible the extension and enrichment of the cultural facilities there. By a judicious use of this short valley region the planners have retained the economic and cultural advantages of concentration, at the same time obtaining the benefits of living close to nature.



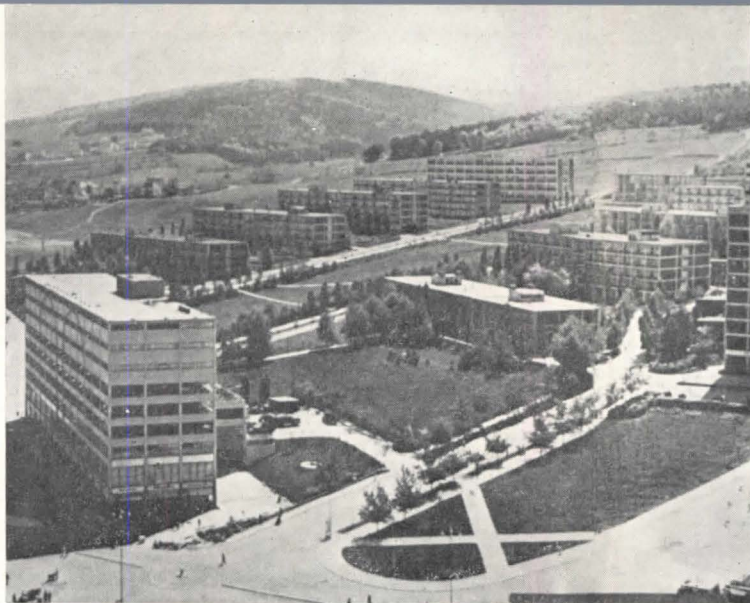
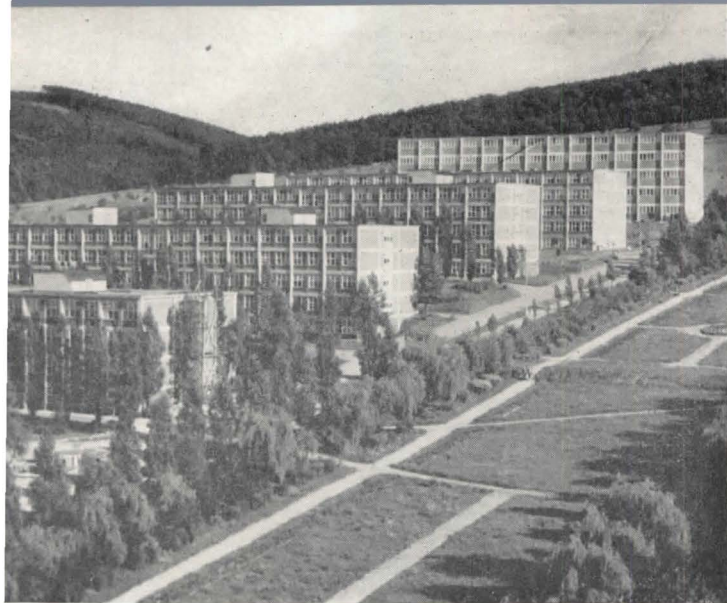

Above, dormitories for student workers range in tiers up the hillside fairly close to the central plaza (shown in the center above). Below, the Administration Building, 1938, noteworthy for its straight-forward expression of the standardized construction used for all major buildings, as described in text



## HOUSING

As part of the same plan, the residential sections of Zlin proper will be supplemented with new neighborhoods in the center of town as well as on the slopes opening to the south. Here some row and multi-story apartment houses, so far entirely absent in Zlin, will be built with the intention of providing not only single family and low row houses with their individual gardens, but also a variety of apartments. By comparing the newly proposed sections, shown at the top of the master plan, with the older ones near the center and in the southwest corner of Zlin, one can observe encouraging progress made through years of planning.

The house type most frequently used until the end of World War II was the two-family wall-bearing brick unit referred to in the discussion of the first residential development of Zlin. Toward the end of the war experiments were started in constructing these houses of prefabricated hollow and ribbed concrete slabs on a mass production basis.

At the end of the war sharply increased building costs and the nationalization of the Bat'a company brought a fundamental revision in the company's entire housing program. Now, in close accord with Le Corbusier's suggestions of 1935, the planners favor the erection of an increased number of multi-story apartment houses, surrounded by park areas. These large apartments can be built more economically than detached houses, and thereby make possible an increase in modern equipment for each unit, and thus improvement in the whole living standard. Several types of such apartment houses are planned, varying primarily in respect to the number and kinds of communal facilities offered. In the future, too, all apartment houses will be supplied with heat from a central power plant.

The simplest of these multiple family houses is already in construction. It is a three-story walk-up of wall-bearing brick designed by Architect Karfik in 1946. Off each stair landing are two apartments having



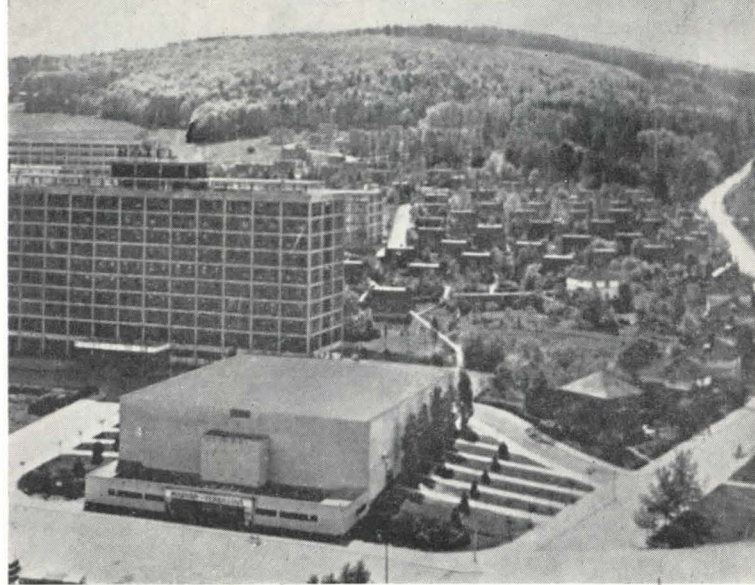

much better plans and bigger rooms than the original detached houses. As a further improvement, groups of these buildings are to be provided with central laundries and nurseries.

A second type of apartment house, eight stories high, of the standard reinforced concrete frame construction, with elevators and a central corridor, will have the common facilities of nursery and restaurant in the building. But each apartment unit will have its own amply equipped kitchen with built-in cupboards and refrigerator, both welcome innovations in this part of Europe.

The third type, which has a more completely collective character, is now in process of being designed. Because of the change in living patterns which such a building implies, one experimental unit probably will be erected first to test its acceptability. The program for this type is based on the results of a provocative architectural competition for the collective housing of workers of a large industrial plant in the district of Most. The drawings entered in this competition by Zlin's chief planner Architect Vozenilek may serve to illustrate this type of building. All the common facilities, central laundry, workshops for tenants and maintenance workshops, administrative offices, and the kitchen serving the central dining room are placed in a well-lit basement. On the first floor of the apartment element are common social rooms, club rooms, a lecture hall, shops, café. In a low adjoining building are a large restaurant and several smaller dining rooms for family affairs. Since the building is planned for families with employed mothers, connected with the building, in a lower wing, are a nursery, kindergarten, and school for pupils up to 14 years old. The children will stay in these schools during work hours and they can remain as boarders for longer periods when necessary. The house planned for Zlin will be smaller and will serve only 100 families as compared to the 300 of the Most project.

*Above, center, about the main square are the department store (with cafeteria for young people), the hotel (a social center, with restaurant, café, billiards, etc.), and the movie theater which serves as a community auditorium. Above, the school group, 1929-35, F. L. Gahura, architect*

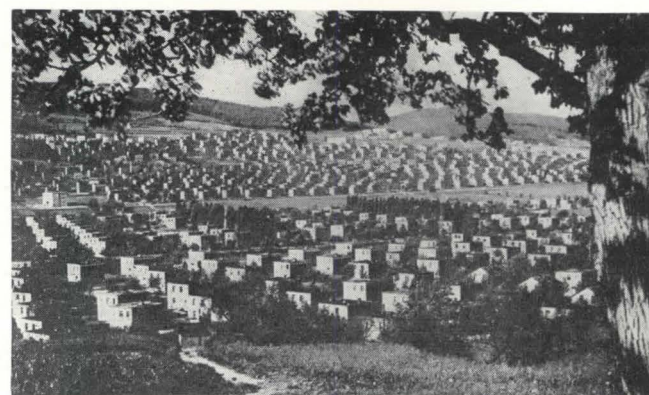

*Above, early standard houses "paid for economy with monotony," but each house had air, sun and its garden. Below, recent prefabricated concrete-slab houses; each provides for two families*





## STANDARDIZED CONSTRUCTION

One of the distinctive qualities of Zlin's town center and industrial section is its unified appearance. In part this is the achievement of essentially good planning and the imaginative relation of buildings to each other. In part it is due to the standardized construction used for all multi-story buildings.

The construction system consists of a basic framing of reinforced concrete. Round columns of a diameter constant throughout all floors are spaced at intervals standard for all buildings. The exterior panels consist, in most instances, of the brick that is used in the residential areas for houses, and of windows as required by the function of the building.

The basic frame has been used for all types of structure. Within the uniformity of this construction system, it is remarkable how clearly the purpose of each building is indicated and how much variety in spirit is achieved. Compare, for example, the school which has low, spreading masses and busy, low-silled small scaled windows, with the museum which stands elegant and quiet in the geometrical precision of its proportions, and the shimmering translucence of its glass sheath. Or compare either of these with the factory's workmanlike storage buildings, panels subdivided into large areas of wall below shallow window strips. The standard frame has also found interesting application in various retail stores of the Bat'a company. The shop in Praha with its big areas of opaque and transparent glass is a good example of its use in a commercial building.

Requirements of machinery layouts in the shoe factories and structural consideration determined the original column spacing of 6.15 meters in each direction. This proved excellent in warehouses and office buildings, and was used without difficulty for dormitories, hotels, community buildings and department stores. From the beginning the standard column spacing had to be altered in school buildings to achieve deeper classrooms and narrower corridors.

More recently, in connection with the extensive reconstruction of factory buildings destroyed by bombs in 1944, the entire structural system was restudied, and the spacing of columns slightly revised to suit new machinery layouts and more exacting plan requirements. The designers are now attempting greater flexibility of column spacing by working with a smaller module of 1.05 meters based on middle European brick dimensions. Column grids for the various buildings are laid out on multiples of this module. The improvements for industrial use are best illustrated by the half-plan of the new factory building erected after the war and designed by Architect Vozenilek (see plan upper left, below). The adaptability of the system to domestic requirements may be seen in the plan of the apartment units of M. Drafa's design for housing in Zlin (see plan upper right, below).

The columns of constant diameter have been successfully carried as high as 15 stories by Architect Karfik in the administration building built in 1938, the tallest reinforced concrete structure in Europe.

The standardization of the constructive system proved

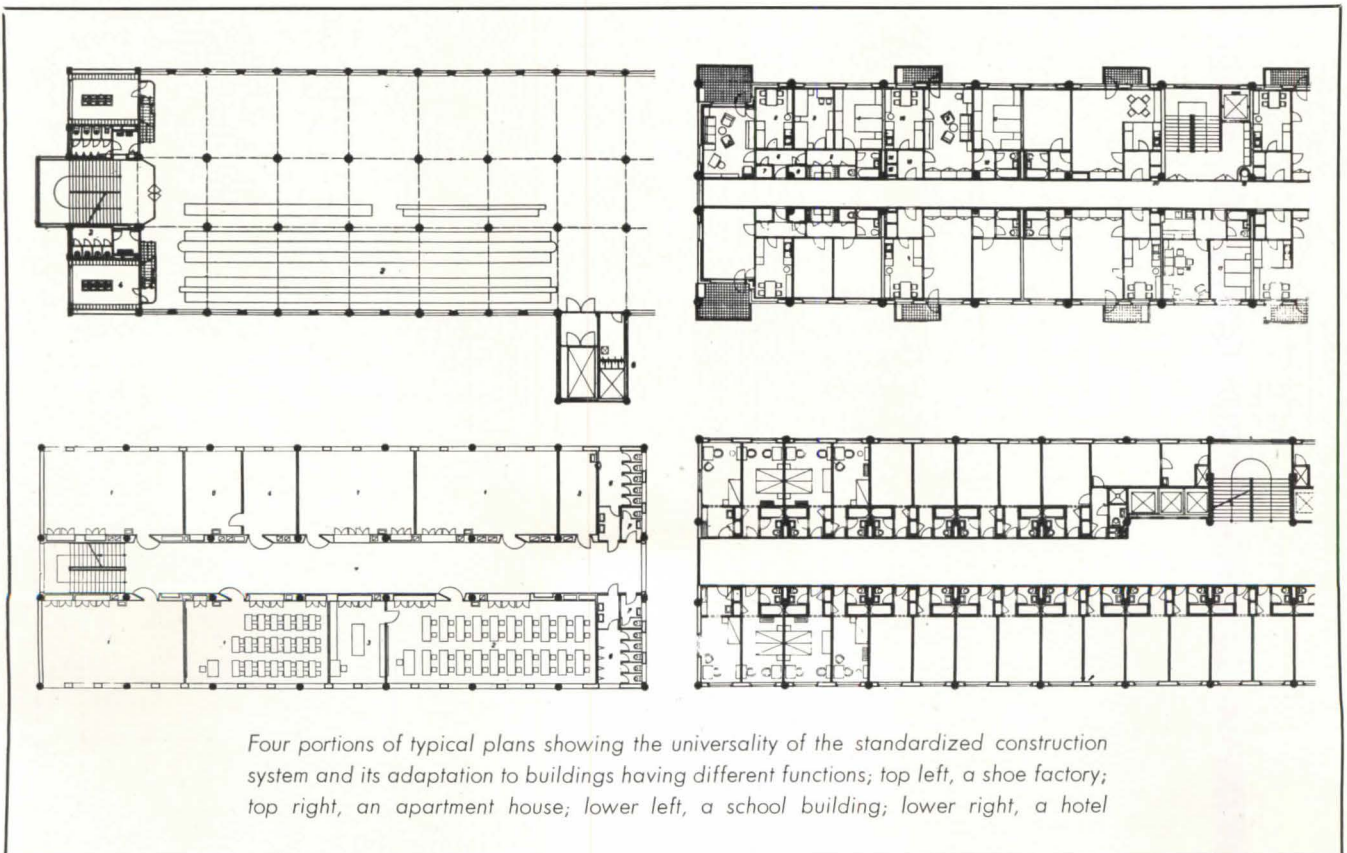



to be economical in terms of the manufacture of forms, of the designers' time, and of the actual erection time which was further speeded by the use of cranes to transport the metal forms and concrete mixture. The entire system of standardization immensely facilitated the rapid construction of the industrial and community buildings which the growing Bat'a Works required first in Zlin, and later in its satellite industrial cities.

+ + +

The coordinated planning studies made in the development of Zlin are proving of great importance to Czechoslovakia today, for they provide a rich pool of experience for the solution of similar problems facing other recently nationalized industries. The men struggling with the problems of regional and local planning are also finding the study of Zlin rewarding.

To the world at large, the city is significant as a rare example of thorough-going city planning. Instead of allowing Zlin to succumb in smoky ignominy to the sprawl and soot which we have come to associate with the cities of the industrial revolution, here men disciplined and exploited the tools of man's ingenuity for his more comprehensive welfare.

*Right, the main retail store of the Bat'a firm in Praha, 1930, F. L. Gahura, L. Kysela, architects. Below, the museum, designed by Gahura in 1933, was built as a monument to the founder of the Bat'a industry*

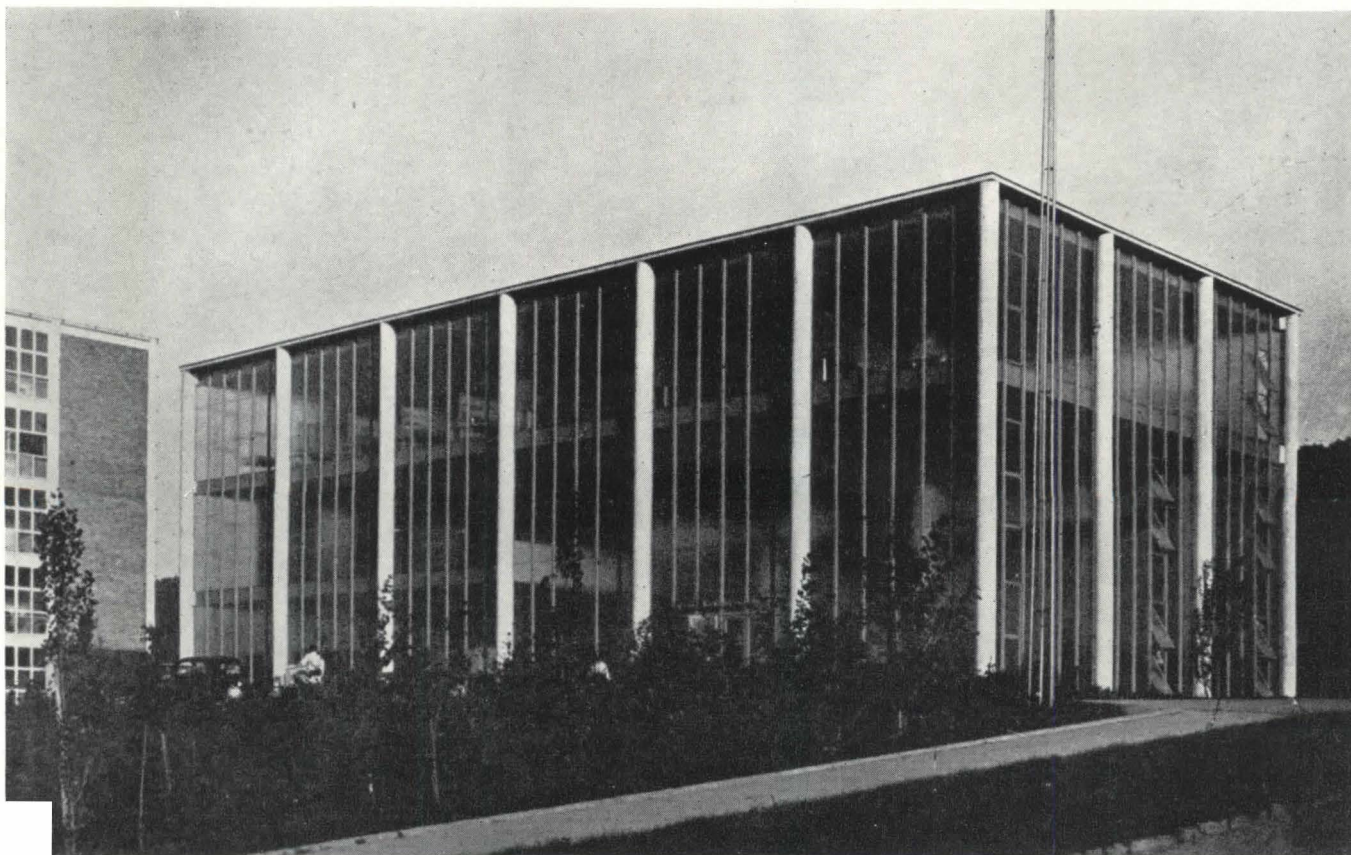
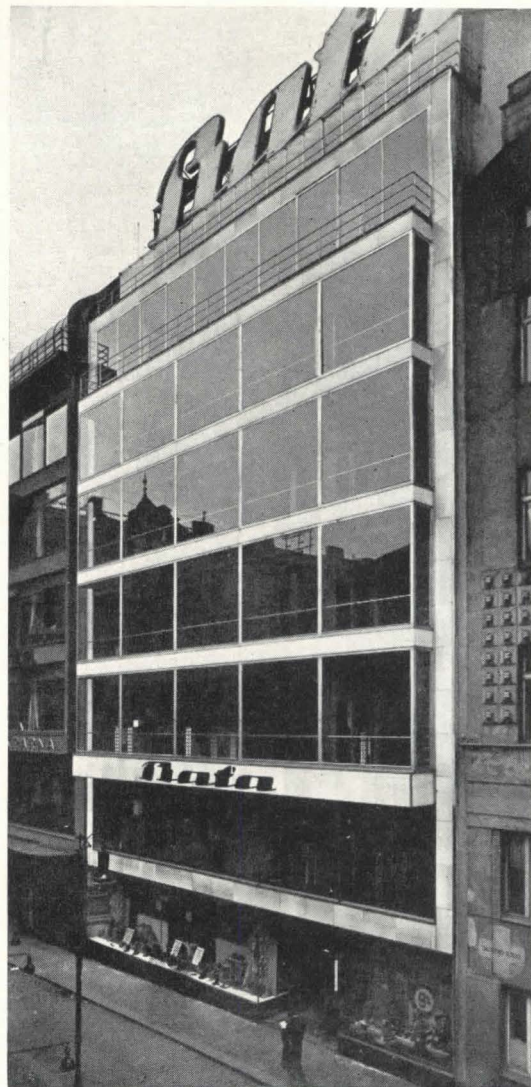



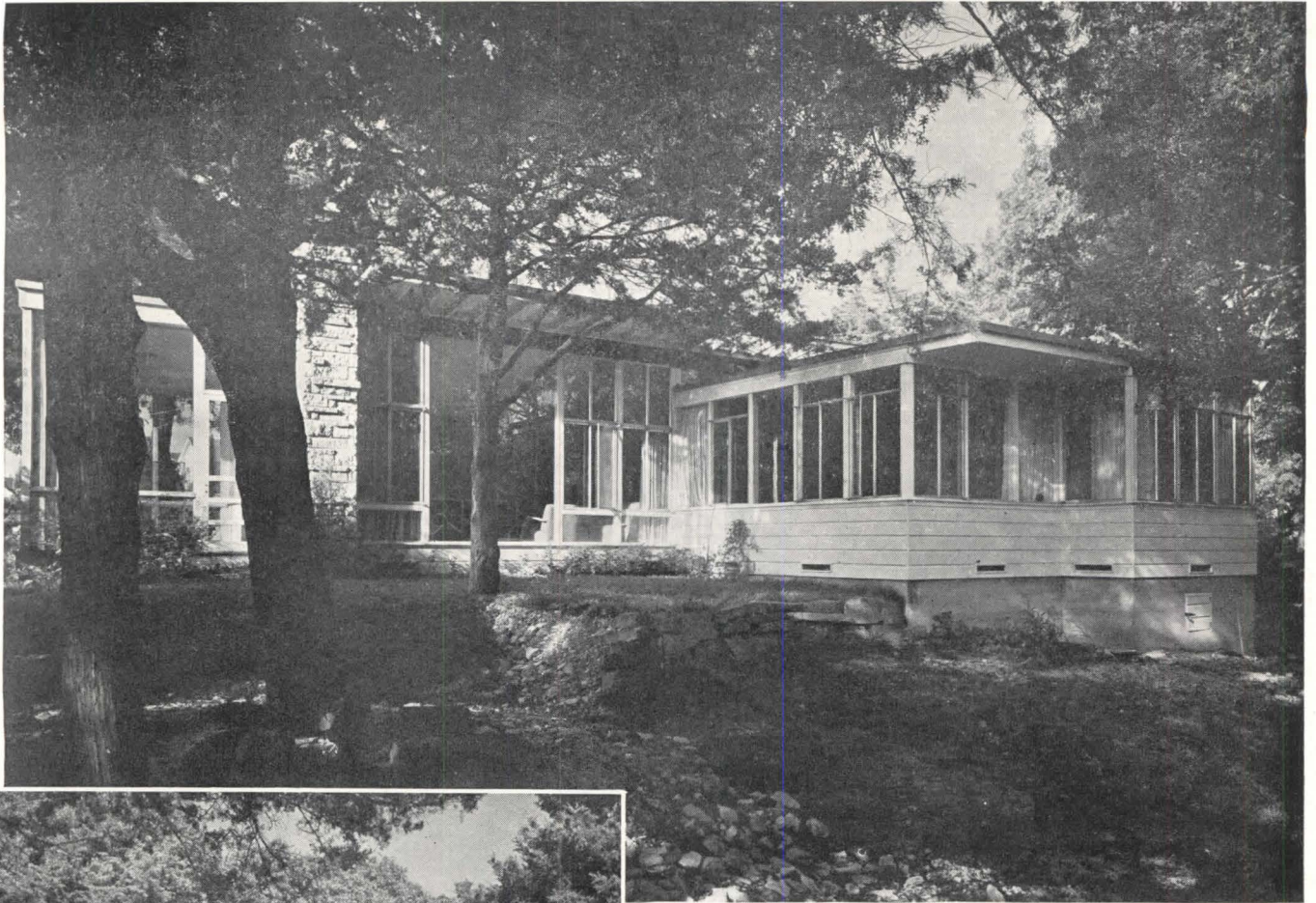

Ezra Stoller Photos



## TREE-SET IN TEXAS

*Home of J. Herschel Fisher, Architect,*

*of Wiltshire and Fisher, Architects, Dallas*

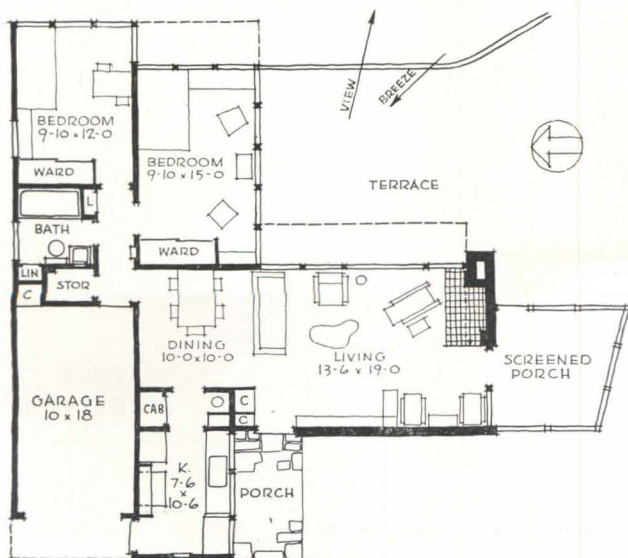

PREVAILING breezes and pleasing views are determining factors in the orientation and fenestration of the homes of the architects as well as those of their clients. The living room, with its screened porch, and the bedrooms, take full advantage of the cooling winds and the wooded landscape. On chilly days one can enjoy the open fire as well as the view of the out-of-doors. Entrance, kitchen and garage are to the west on the street side of the plot. From the garage one can enter directly either the kitchen or the living quarters. The living room ceiling rises toward the view and the combination of dining and living room areas adds to the spaciousness.



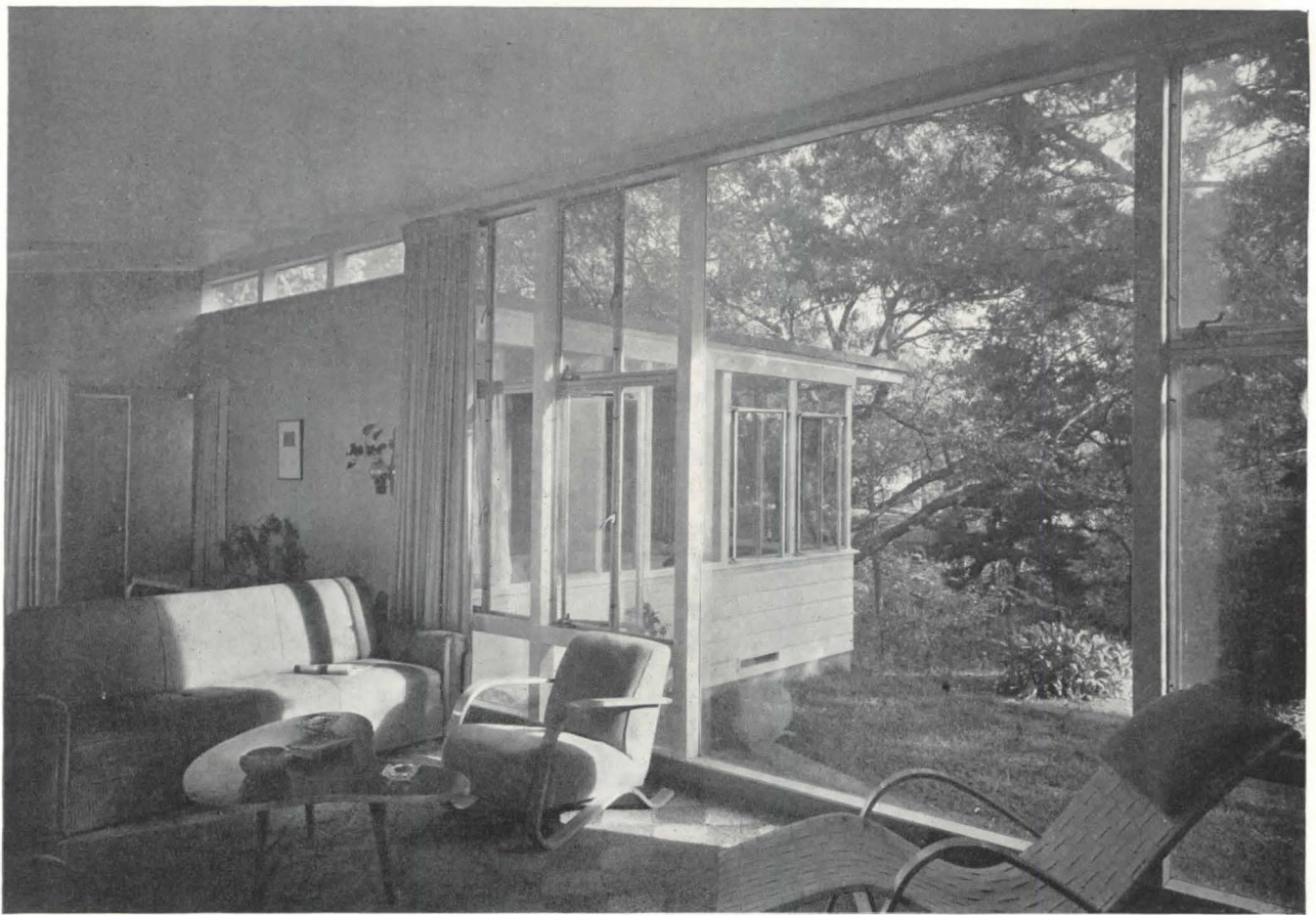

*A floor to ceiling window invites an unobstructed view of the wooded hill, while side sash provide ample ventilation and the projecting roof shields the rooms from sun glare. Walls are of warm pine plywood, drapery gray, some chair upholstery blue*

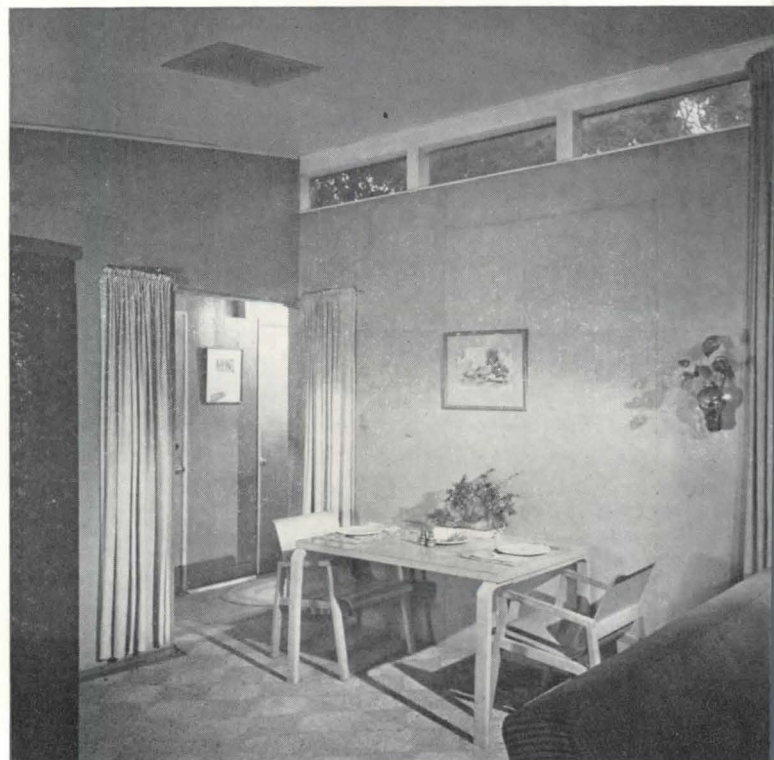
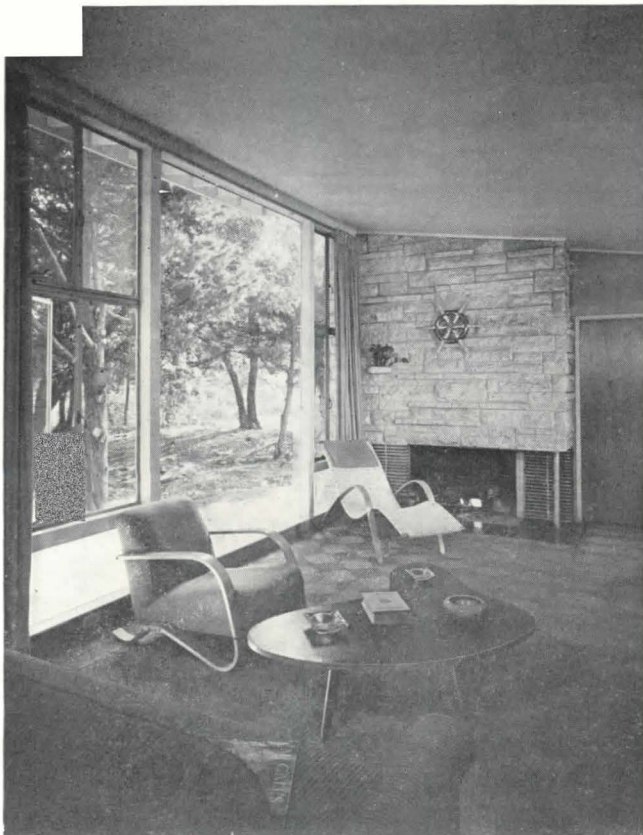



East and south sides of the master bedroom are glass enclosed above chair-rail heights, giving unusual spaciousness and airiness as well as a panorama of the countryside. Casement windows catch the cooling breezes. Convenient built-in features and furniture unify an uncluttered room

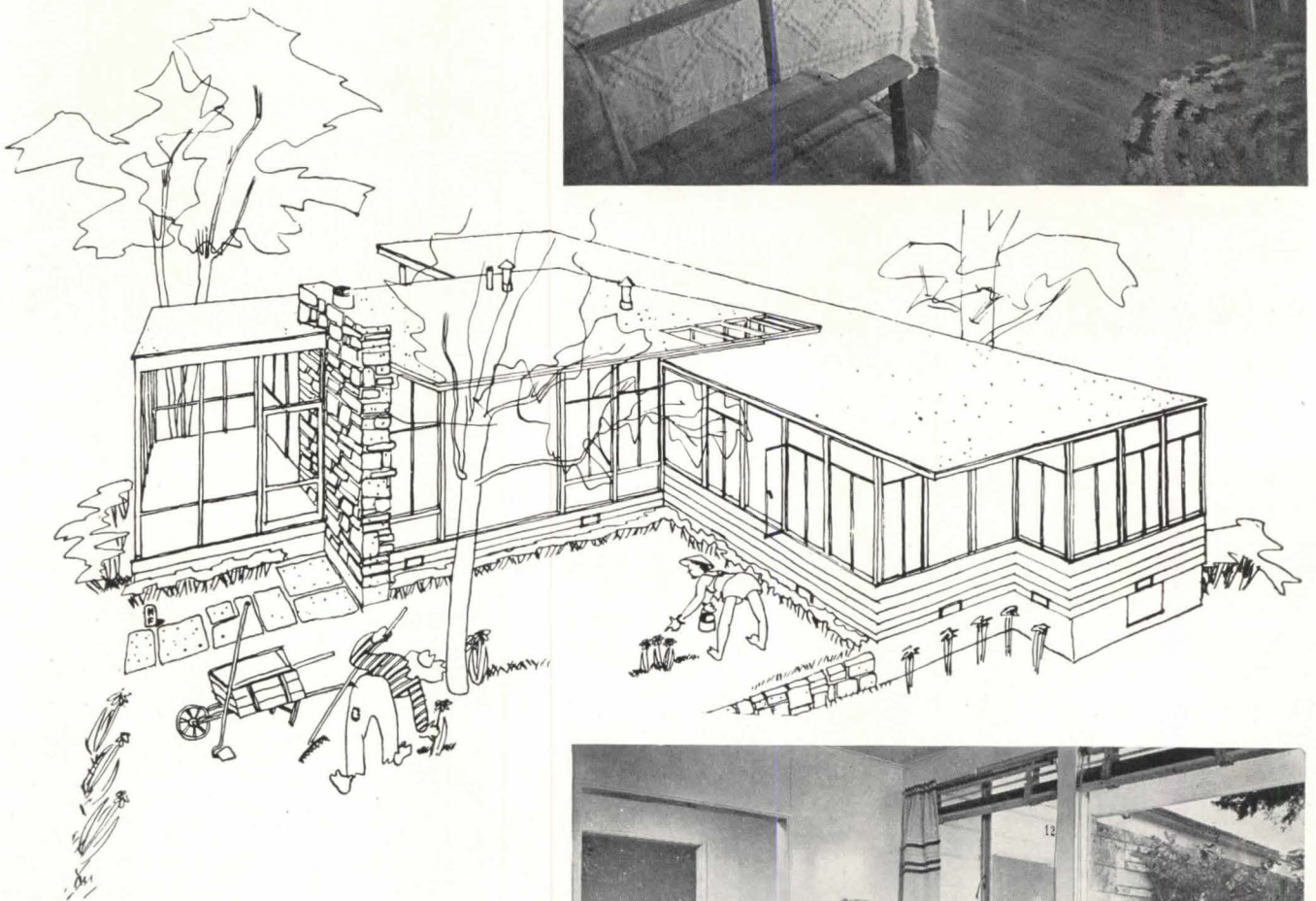
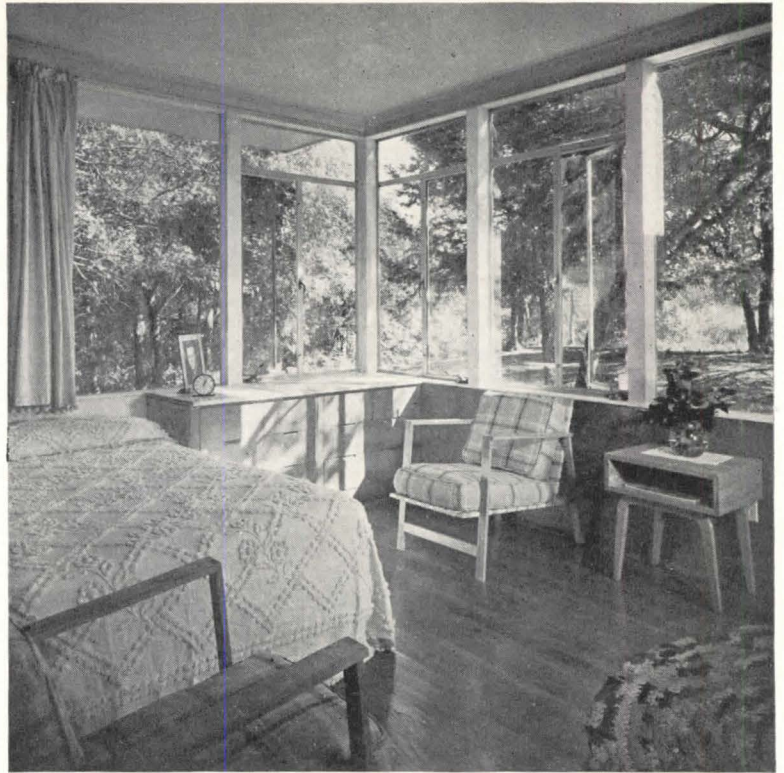

The architect's early tree-top-perspective corresponds closely with the down-to-earth photograph at the top of page 76, except for certain human elements. The kitchen was designed to be as pleasant as convenient, flooded with light and air, planned to save both steps and tempers







1. The polyclinic building in the foreground; main building beyond

## A CENTER FOR MOTHERS AND INFANTS

*Tacubaya, D. F., Mexico*

*Enrique de la Mora, Architect*

MEXICO'S most creative architects are devoting their talents to the country's comprehensive health program which includes all types of hospitals and health and welfare centers. The center at Tacubaya is one of the most unusual and interesting in both plan and structure. Its three functional divisions have been made three separate buildings connected by intriguing ramps and covered passages.

The polyclinic section is housed in a three-story building. The ground floor is devoted to dormitories for the temporary accommodation of mothers; the second floor provides for medical prenatal and postnatal examination and treatment, complete with laboratories and radiological equipment; the third floor provides various

treatment rooms, laboratories and an operating suite.

The largest portion of the center, with its patios, provides administration and admission offices, the classrooms and terraces, dining-room and kitchen, the music room and other services and utilities. The playground is adjacent to the classrooms.

The third functional division, straight back from the entrance, is the auditorium, below the outer segment of which are exhibition rooms.

The design and construction are imaginative and interesting, yet clean-cut and straightforward in detail, lively and dynamic in feeling, intriguing in form and in the play of shade and shadow. (Numbers on the plan show the approximate camera locations.)



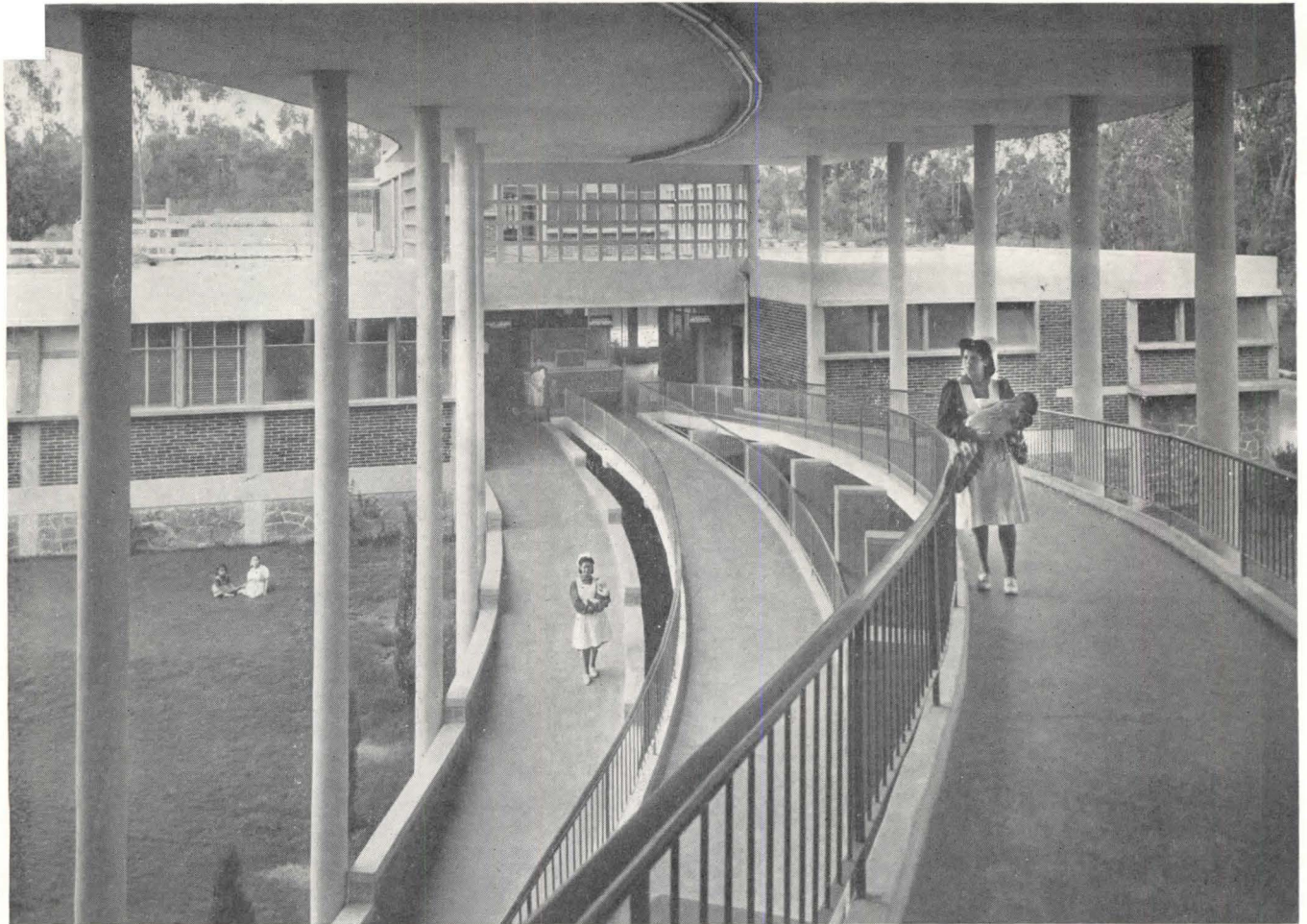

2. From the main building three gentle ramps lead to the three floors of the polyclinic building

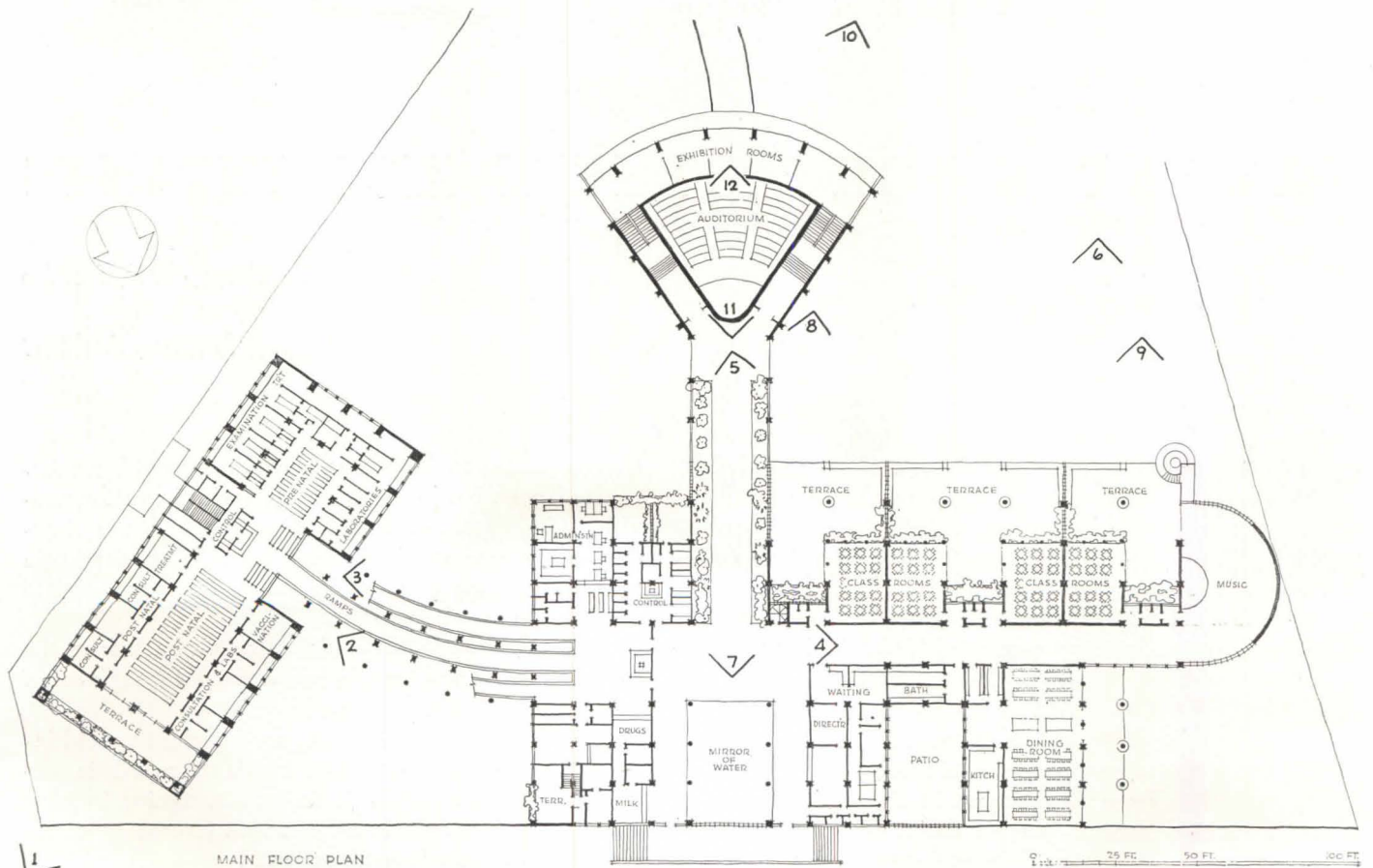





3.

3. Ramps to the upper floors of the polyclinic building cantilever from a row of center posts. Slender columns carry the sheltering roof slab

4. Below, mothers and children await admission before being directed to their proper rooms. Note light from reflecting pool at the left, glimpse of ramps through door at the right

4.





5.

5. Looking back from the auditorium walk toward the schoolroom terraces with their shadow-casting treillage

6. A free-standing stair and slide winds from the roof of the semicircular music room to the play yard

7. A step-roofed walk leads from the main building to the auditorium

8. Looking from the auditorium toward the main building

9. Play area, sand box, slide and stair, terrace and classrooms mean much to the children, and mothers

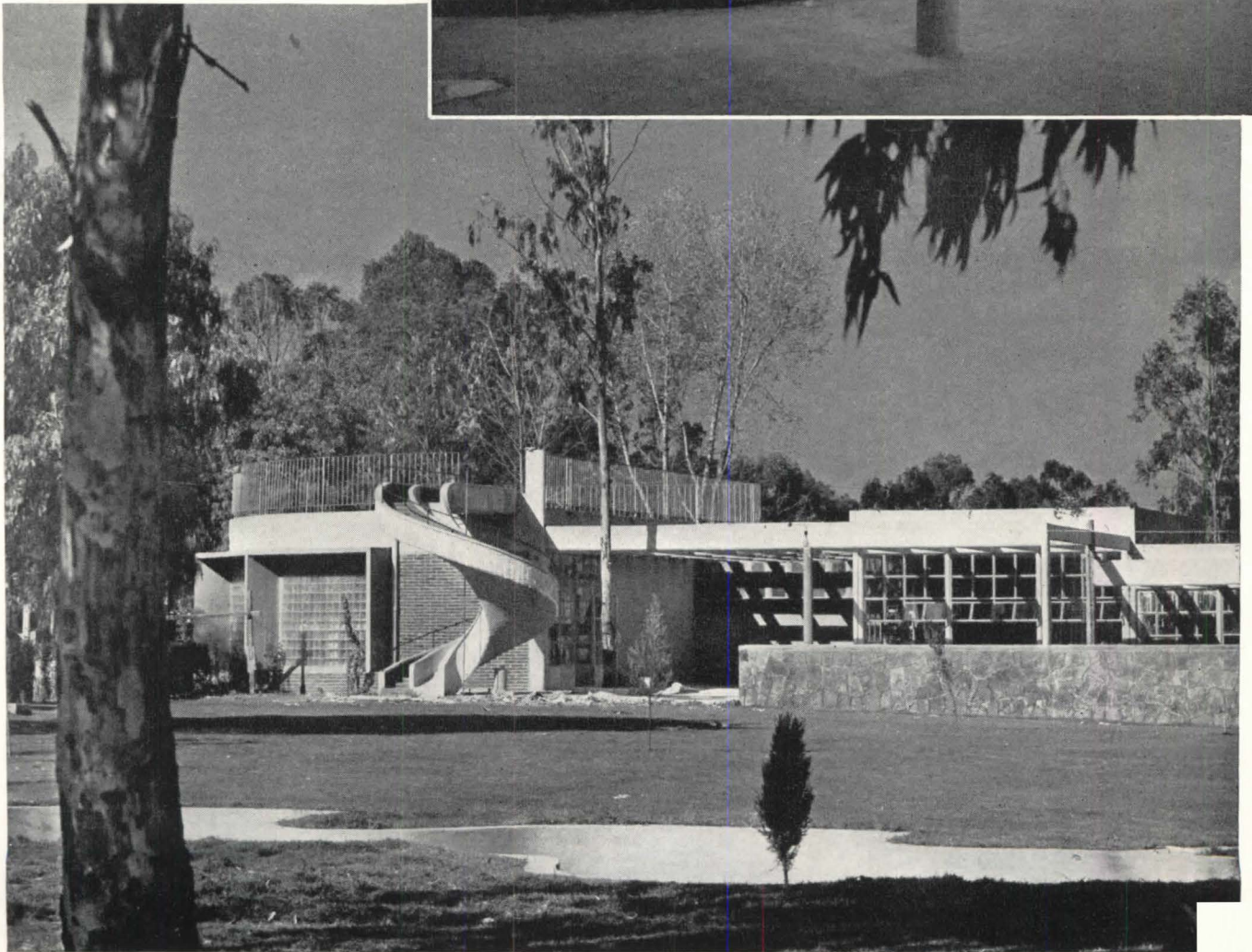
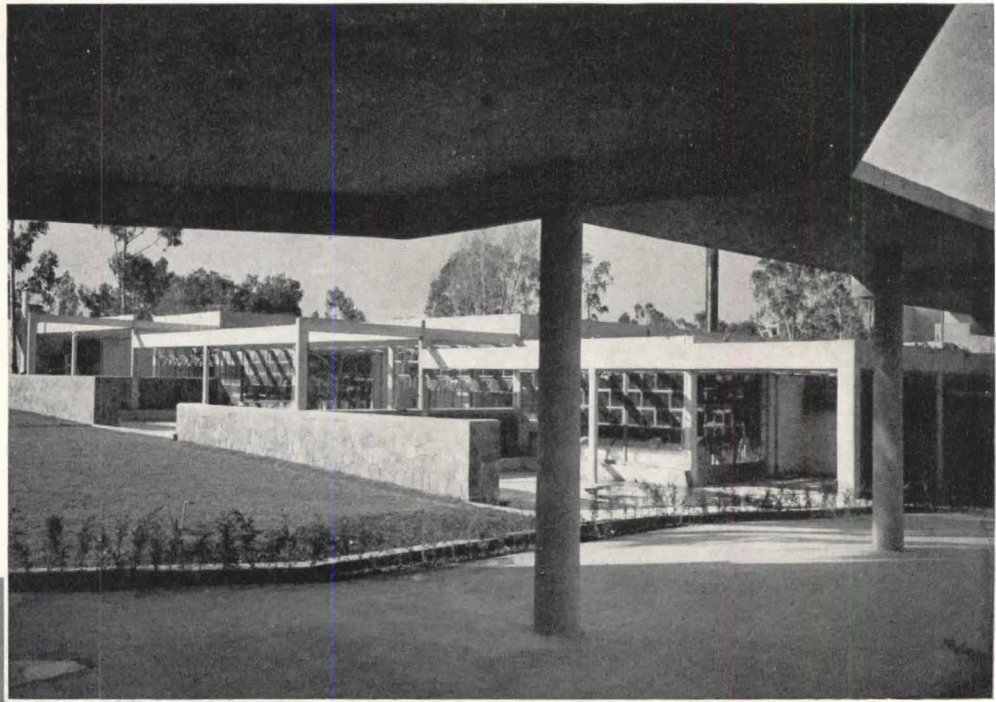

6.



7.

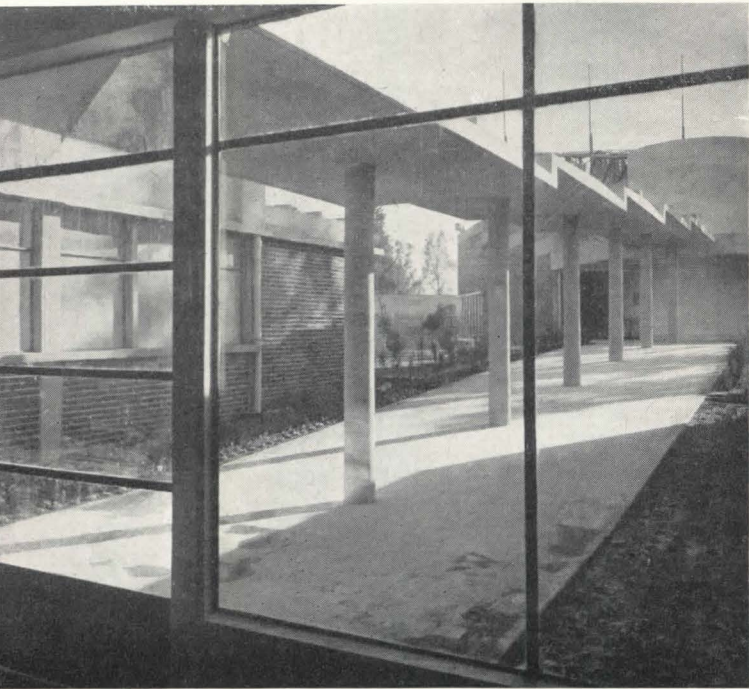

8.

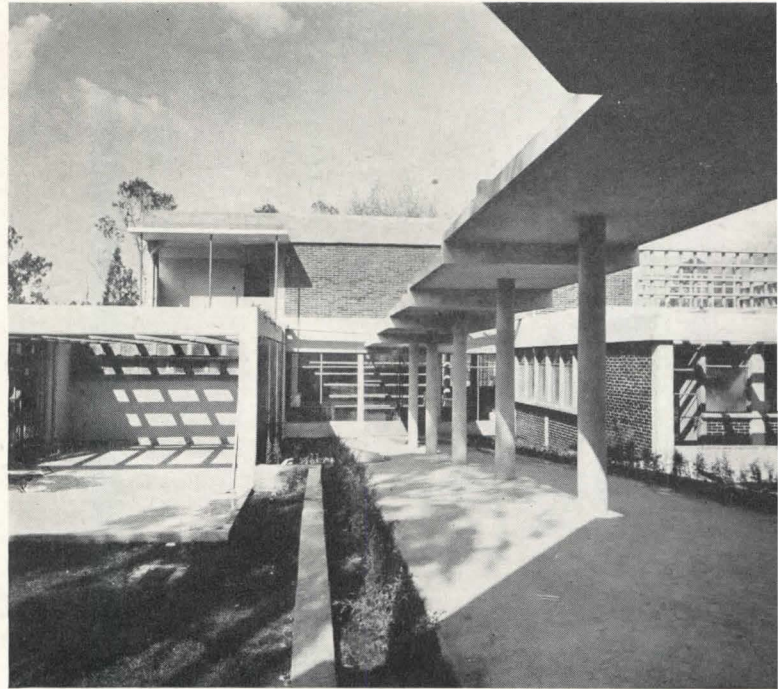

9.







10.

10. The auditorium is an interesting example of an exoskeleton in which the exposed structural elements constitute major design forms and produce unusual shadow effects. Problems of weather-tightness and increased maintenance costs are frequently deterrents to more universal acceptance of such structures

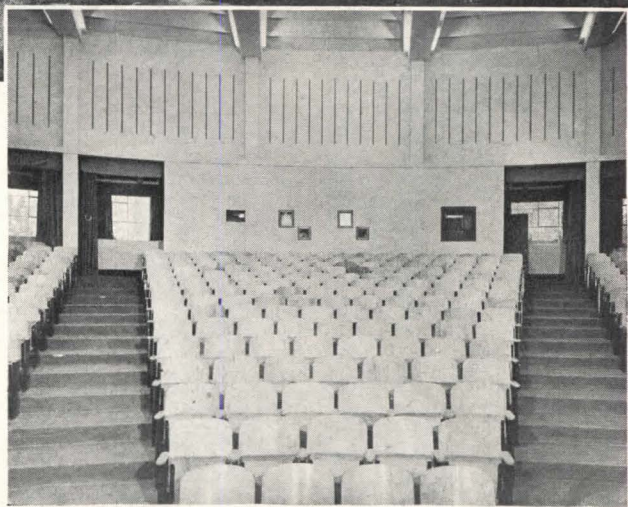

11.

11. and 12. Interior views of the auditorium showing its pitched floor, stepped ceiling and indirect lighting channels

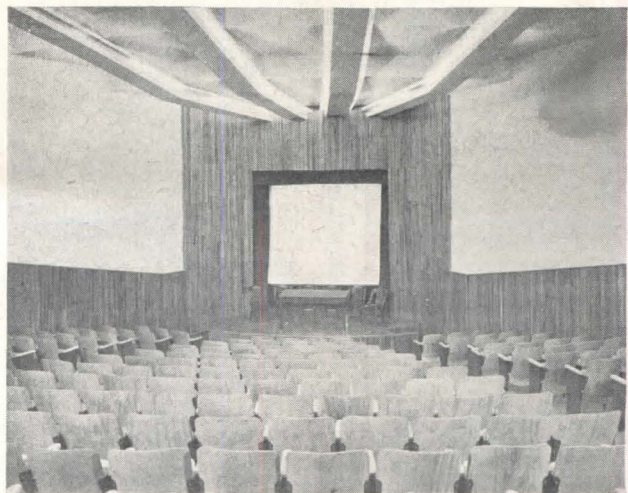

12.



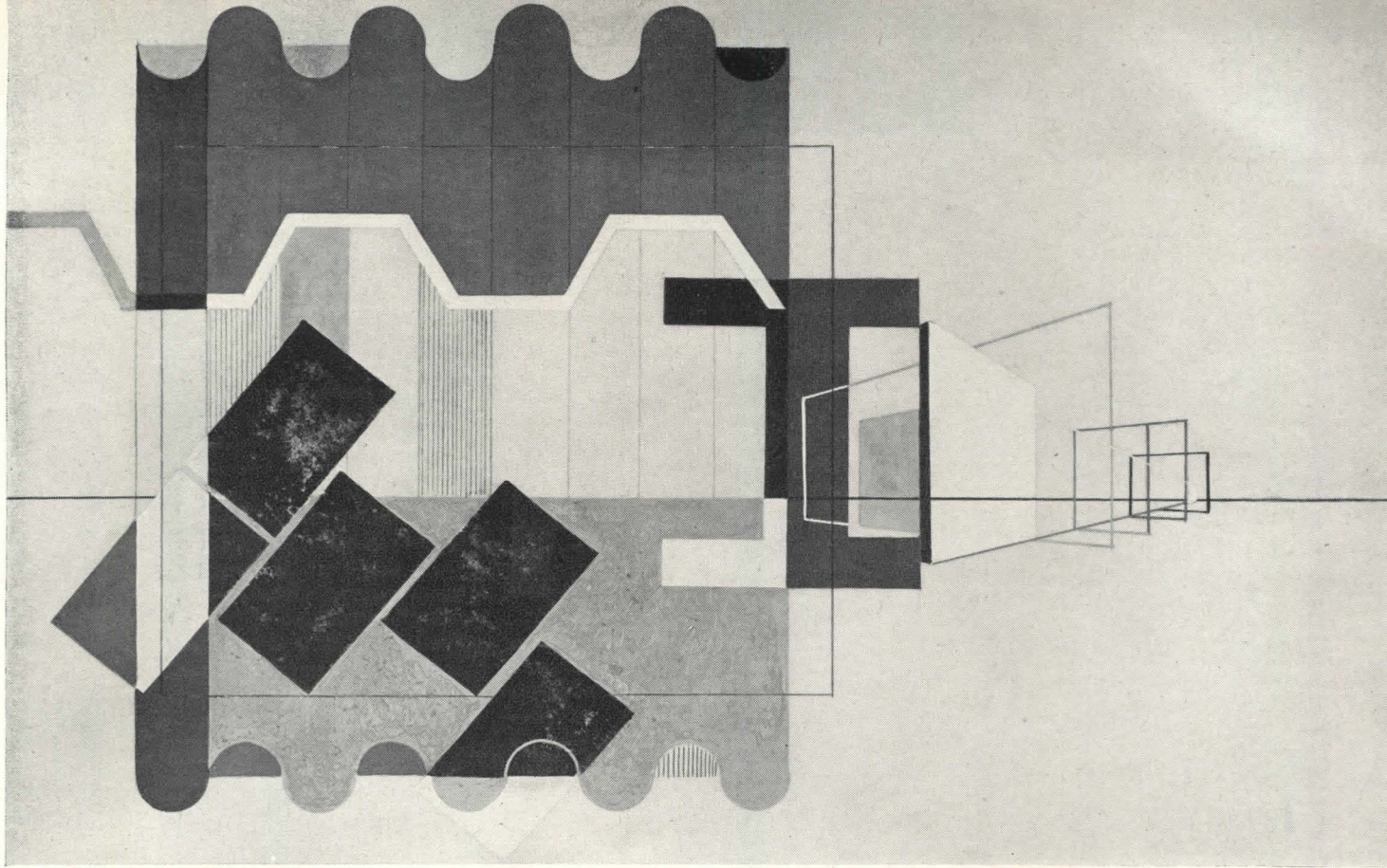

# INDUSTRIAL BUILDINGS

ARCHITECTURAL RECORD'S

BUILDING TYPES STUDY NUMBER 128

**N**ow, almost two years after the end of the fighting war, the small industrial building has its day in the sun. The end of the war saw the country (or so it was said) glutted with factory space. There was supposed to be a depression in the offing, too, or at least a period of serious readjustment. Who would want to build a factory?

Well, many did, it soon developed. Those who wanted priorities or at least permission to build factories knew well enough why. The small industry, like the large one, had had its violent upsets; it had changed products, methods, machinery, workers and ideas. And industry cannot abide obsolescence in quarters — there is too much lost in inefficiency. So small industries beat at the doors of the OPA for permission to build, in defiance of doleful statements that building costs were too high.

Building costs were high, and still are. And many a plan has been put on the shelf. But it is also true that in many not untypical instances high building costs

are not so compelling to management as high costs of production in inadequate or inefficient buildings.

And now, finally, the all-clear signal has been given from official Washington. Anybody who wants to build a plant, and can pay for it, can, without permit. The materials situation is much improved. The much-heralded recession seems to be receding. Construction should proceed in good volume.

So this Building Types Study is particularly addressed to the smaller architectural firm — small at least against the huge architect-engineer organizations which did so many great war plants. The typical architectural partnership is peculiarly well fitted to design small industrial plants. The new plants have new needs, new challenges; they will not follow standardized schemes. They will need imaginative inquisitiveness and close localized acquaintance. They will need, in short, the typical architectural organization with its ability to analyze problems and provide efficient attractive solutions.





## THE ARCHITECT'S OPPORTUNITIES IN FACTORY DESIGN

*By Roland A. Wank*

*Associate, Fellheimer and Wagner, Architects and Engineers*

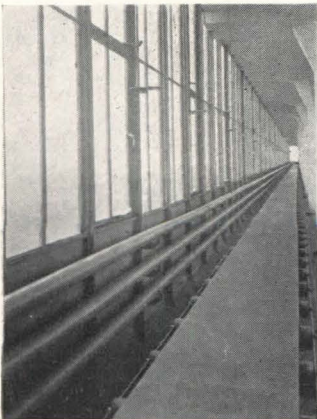

*Two views of the Van Nelle factory, Rotterdam, Holland; Brinckmann & van der Vlugt, Architects. One of several cited by the author as examples of progressive work by the "general practitioner"*

**T**HE WORDS "industrial buildings" seem to make one think of a large plant. Factories which occupy space by the acre rather than by the square foot are very conspicuous, with their long, low buildings, tall stacks, tanks and enormous parking spaces; it is natural that at home as well as abroad they are accepted as typical of American industry.

Yet an astounding amount of production still takes place in structures not even remotely within this concept, and the small factory is probably more typical of American industry than the more-publicized giants. Certainly it is the small plant that concerns the architectural profession today, particularly the smaller design firms to whom this article is addressed.

Aside from the obvious timeliness of this preoccupation with the small plant, there are other fortunate cir-



cumstances that bear upon it. One, equally obvious, is the availability to the typical architectural organization of architectural commissions for small factories. Another is the scope they give to the imaginative inventiveness that seems the birthright of the architectural partnership. For the small plant offers no less freedom, certainly, than the large — probably more. And, of course, the opportunities are more likely to be right in one's own backyard.

The manufacturer who needs a new plant may be housed in structures that were adequate and conformed to safety standards and working conditions of the past, but have not been kept up with the times. Buildings well constructed in the beginning and well maintained will remain structurally sound indefinitely. As production grows in long-established mills, it may be accommodated in part by the installation of higher speed machinery, in part by additions to the building here and there to meet immediate demand, and in part by crowding — into aisles, basements, garages, temporary outbuildings that become permanent, and so forth.

The older plant is likely to be surrounded by areas of high density and high land prices; therefore its expansion is difficult. But the owners and managers are probably comfortably settled, and employees, especially the skilled older men to whom management talks on a first-name basis, are rooted in the vicinity. Removal to a new location seems undesirable. Therefore inefficiencies of the plant — cross-hauling and difficulty of inventory control between helter-skelter departments, lower production rate and higher percentage of rejections due to poor lighting or crowding, high absenteeism due to bad heating or ventilation — are often overlooked. Loyal old employees, on their part, accept obsolete sanitary facilities, make shift without cafeterias or parking spaces, and grow accustomed to the inadequate exits and other safety hazards. The plant may depend on the equivalent of some "grandfather clause" in the building regulations, or on the personal friendship of enforcement officials, to avoid major structural alterations.

But even in brand-new industrial areas one may find counterparts to the old and physically obsolescent factory. New ventures, started by aggressive and imaginative local citizens in garages, old barns and such, often become healthy industries. Their quarters, however, frequently remain a series of improvised additions, just as inadequate and inefficient.

With both types of smaller plants, the close ties of the community with the industry often prevent removal to a new location and permit continuance at rather low standards. But in this respect there is a perceptible change all along the line, and the change represents an opportunity for the architect.

Among the causes of change, an important one is mobility of labor and expansion of payroll, both of which were accelerated by the war. Men brought in from elsewhere, and even the boys of the older workers returning from the war, are as a rule more impersonal in their relations to management, and have more back-

ground for appraising the quality of working conditions. The growth of unions tends to make employees more vocal.

On the other hand, a parallel change takes place in the thinking of management when retiring older hands are replaced by the brisk young college graduates, trained in engineering, business management and efficiency methods.

Competition and increasing mechanization add their influence toward overhauling plant layouts and buildings. Few industries are secure enough to forego the latest wrinkles in new production methods. There comes the time, then, when increased power requirements, higher steam pressures, new problems of heat, fumes or mechanized handling can no longer be fitted into the limitations of the old buildings.

An observant architect should be able to make a fair guess as to the degree to which plants in his vicinity have been affected by such trends, especially in smaller communities where a good many such matters are common knowledge. Even if he were a little forehanded in establishing relations with local industries, the interest he has shown and the knowledge he has gained may pay dividends later.

Some missionary work may be needed, of course. Industries which did not use architectural services in the past may be quite genuinely surprised that the architect has so much to offer.

Most factories have some engineering staff that concerns itself with the maintenance of buildings, grounds and utilities, often also with equipment and service connection changes. From that base, the activities of the staff may spread to encompass planning and purchasing new equipment and the building alterations and additions incident thereto. From there it is but a short step to responsibility for the layout of the entire plant, "master planning" for the future, and often the design of new structures. In medium-sized and larger factories even construction of buildings may be handled by an expanded maintenance staff, the dividing line between minor alterations and major additions being hard to draw.

In other cases, such "plant engineering" departments prepare plans which are essentially graphic statements of requirements, and then make the mistake of turning directly to a building contractor for working drawings, estimates and building permits. This error is natural, because the aspect in which management is usually most keenly interested is the cost, and the contractor is accepted as the authority on that subject.

It wouldn't do, of course, to condemn such procedure as vicious in itself. Any procedure is as good as the men are who carry it out. But it would hardly be unfair to say that the chances are strongly against the owner's receiving the best possible service in that fashion. The engineering staff, whose original responsibility was maintenance of the premises and their day-by-day adaptation to process changes, is not likely to possess the temper, experience, or far-sighted vision best suited for long-range planning or for the design of buildings



which will successfully justify their investment cost over a long period of years. The staff's familiarity with plan schemes, design approaches, materials and construction methods will be limited. Policies affecting building design like employee services, fire protection, natural vs. artificial lighting and ventilation, as practiced in other industries, will be beyond its normal scope. It is quite likely to overlook factors which lie outside the factory fence, though they are important in determining layout within, such as highway or railroad changes, shifts in the residential distribution of the labor force or in their manner of commuting.

Nor is the building contractor a generally dependable



*Benet factory  
Barcelona, Spain  
Robert Maillart  
engineer (1924)*

source of all the information and analytic reasoning that should be precedent to any sizable investment. His normal business does not require — and his normal profits do not permit — the maintenance of the relevant skills on his staff. Aside from that, of course, his direct employment eliminates competition, and while that may have been a less important matter under certain wartime conditions, it is hardly advisable as general policy.

If the architect isn't in the picture sketched in the preceding paragraphs, still every obsolescent plant means a potential commission. Many of them will fit within the scope of the unspecialized practitioner. In prosperous times there is little competition for the design of smaller plants from the specialized architect-engineer, whose elaborate organization does not thrive on projects of moderate size.

As to the all-important question of first contact with an industrial client, the writer has no suggestions to offer. It may be noted in passing, though, that many clients of normal practice are just the men who manage plants or sit on boards of directors. Architects design their homes, office suites or salesrooms. It becomes then a matter of convincing them that the same architect can supply equally valuable services for their plant problems.

The first question of an industrialist may well be why the employment of an architect will save more than

his fee; the second, why it will produce better results. As to the first, one may assume that every architect has at his fingertips the arguments for separating the supervisory function from the activity to be supervised. As to the second, there is no ready-made answer beyond the general observations made in earlier paragraphs. It would hardly be a convincing claim that any given architect will design better buildings than any given plant engineer or contractor. It must be demonstrated that in a specific situation a particular architect will do so.

It must be assumed, of course, that the architect bent on getting such commissions has devoted a good deal of study to the matter, beginning with published material on plant design and construction. Many plants are open to the public; and for others, permission to visit may be obtained with little effort. Plant managers and engineers are often quite anxious to explain the good points of their establishments to visitors showing genuine interest, and a few calls to factories in similar lines will store up a very useful volume of information.

Some direct observation of the plant in question may also turn up pay dirt. Type of employees, manner of transportation for employees, business callers and goods, parking problems, lunch facilities are worth noting. Quality of maintenance, adequacy of lighting — natural or artificial — may often be judged from the outside. Number and type of buildings, lay of the land, space for expansion should be remembered, and as much of the flow of materials and products as the architect's training permits him to recognize. Newspapers and easily-tapped common knowledge may give him some insight into the status of unionization and of labor-management relationships.

Armed with such preliminary information, then, the architect may be in position to make at least a few intelligent comments. His life-long preoccupation with the reactions of people to their physical surroundings will probably qualify him to make valid remarks on matters of employee relations, working efficiency, effect upon the public. He might explain that a building is not truly functional unless it fulfills all possible functions — and among those are attracting the choicest types of employment seekers, holding satisfied employees, impressing the public and promoting the sale of the product.

The next step might be an invitation to study the factory from the inside. The purpose may be general recommendations for improvement, or a master plan for the guidance of development, or the placement and establishment of general characteristics of a contemplated specific building unit. A prosperous plant will almost always lack space and the manager will carry an expansion project up his sleeve. Few plants except the very large ones will have up-to-date master plans, yet most of them will disclose examples of unplanned additions that were later regretted. Thus a wide-awake architect is likely to find some solid meat in his survey.

On the whole, though, understanding of the process of manufacture will be essential for intelligent comment.



Some processes are simple enough so that a few hours may convey a general idea of sequence and requirements; others — especially in chemicals — may be really understood only by experts. In most industries, though, a few days' observation coupled with explanations given by the plant personnel will suffice for a nodding acquaintance. By and large, the architect will recognize where materials come from, in what shape, quantity and by what means; what is done to them, and how they are stored and shipped. By way of caution, bright ideas should be checked with the plant personnel. The brighter they appear, the more likely it is that others thought of them before and that they were rejected for considered reasons — though the same considerations may not apply under changed circumstances — and the disregard of the obvious is a widespread habit.

By then the architect must show his mettle in bringing back to the client a reasoned, documented statement of the sort that is useful to determine a course of action. And it is a fair bet that the next talk may be devoted to the terms of the commission.

The architect with a smaller, unspecialized practice faces such planning and, later, design problems with equipment quite different from that of the big architect-engineer firms. He will be somewhat handicapped by not having all required engineering skills in his own office. On the other hand, he may exploit some of the potential virtues of smaller scale and of the perspective given by the variety of non-specialized practice. If his overheads are substantially lower, he may have a natural advantage in dealing with smaller plants which require more study and detail in proportion to the investment, while the large office depends on vast projects with extensive repetition of uniform elements.

The handicap to which reference was made must be overcome by extra effort. In the nature of industrial work, utilities assume great significance. Steam and electric lines will have larger capacities and will operate under greater pressures or voltages. Water supply may be of several different kinds, requiring multiple systems and special methods of treatment. To normal storm and sanitary drainage, one or more process sewer systems may be added. There may occur other distribution systems for gases, fuels, compressed air, etc. Handling of goods may be a substantial part of production cost, and wise choice between mechanical systems may be important. Problems of ventilation and temperature control may be quite complex and oversize as to capacity. Column spacing, clear height, structural systems and design loads influence not only construction costs and efficiency of the immediate operation, but also future flexibility. Fire and explosion hazards, sabotage and theft may assume proportions quite different from those encountered in other fields of practice.

In addition, of course, process layout is fundamental to building design. Processes are rarely unalterable, and never stay put for any length of time. Space requirements, sequence, and number of employees may be changed overnight by new inventions. Even with given components there may be choices between one- or

multi-story buildings, consolidation or division between structures, accommodation of certain steps indoors or outdoors, and so forth.

The proportionate importance of correct solutions — as compared to matters more commonly considered to fall within the architect's scope — is greater and more critical.

---

*TVA Consumer's  
Cooperative  
Roland A. Wank  
principal architect*

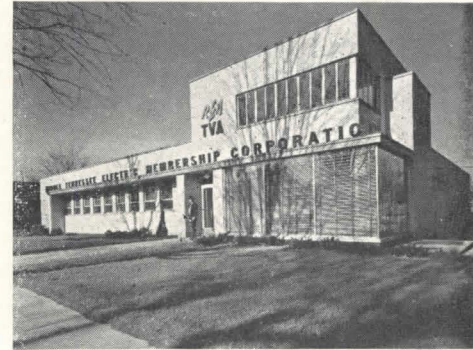

---

On the other hand, it may be said more or less flatly that there is nothing so esoteric in the listed problems but that it will yield to common sense analysis. And after the first few — and rather strenuous — projects the architect will find that these things fall into a sort of natural pattern which makes it easier to deal with them.

Aid may be enlisted from at least three sources. First comes, of course, the plant personnel, who will have definite opinions, subject to check by the architect's skill and — sometimes — pure intuition.

Secondly, engineering consultants can be readily found for structural and utility problems. Independent process engineers are less easy to locate, especially for smaller projects; and plant managements may be skittish about exposing their special know-how to expert observers.

---

*Hat factory in  
Luckenwalde  
Germany (1921-23)  
Eric Mendelsohn  
architect*

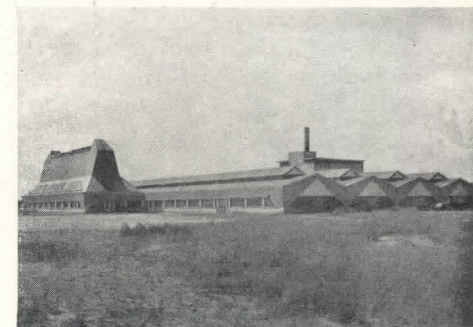



The third source of help is the equipment manufacturer, and he will often take the place of the process expert. New production machinery is almost always involved in industrial building projects. Sometimes the machines, furnished on long delivery dates, have been on order long before the architect entered the project. The manufacturer's staff is ready to give advice — subject, as may be noted again, to the architect's own critical examination. Besides the production equipment firms, the manufacturers of ventilating, hoisting, conveying and other general-purpose equipment have expert staffs, often with members specially familiar with the problems of particular industries.

The question is quite likely to be raised by somebody: given all the specialized knowledge available at the various sources, why is the architect peculiarly fitted to coordinate it into the form of a project? True, he also supplies specific services, but inasmuch as they relate primarily to enclosure of process and to auxiliary buildings, they deal, in the first instance, with financially less important components of the project.

But the answer can hardly be generalized, because, as said before, its validity depends upon the relative skill — perhaps one should say genius — of particular persons in particular situations. Any person, regardless of occupation, may be a natural-born planner and coordinator.

The following two propositions may, perhaps, be argued on strictly logical grounds.

First, that the architect is more likely to be endowed with such natural gifts, because it was that bent which predisposed him to choose architecture to begin with.

Second, that his training and experience tend to develop the inclination to size up problems in their entirety, to be aware of future consequences of present

to develop his own precedent as he goes along. Suffice it to say that he has ample opportunity.

There remains, perhaps, something to be said about the desirability of more smaller-scale organizations all over the country working their way into the industrial field.

From the architect's own point of view, the matter is obvious. Plant construction is a major sector of the building industry, in which the architect could have a greater share than at present. It comes in units large enough to be very desirable to the normal architectural office, if not always for the super-firm.

But there is also a public interest involved — the stake we all have in a brighter, cleaner, and if the word is permissible at all, a more *beautiful* country; in greater amenities, less waste, more joy in our daily surroundings — for those who work inside and for those to whom factories are a part of the landscape. The architect, far more than the plant engineer, the contractor or the process expert is competent to procure those plus values that taken together spell civilization.

And the smaller architect is perhaps peculiarly fitted to make a contribution, at least with respect to the average-sized plant.

During the last few decades there has grown up a sort of standardized concept of factory construction, derived mainly from the oversized mass-production plant. It is celebrated all over the world — yet its very standardization may lead a skeptic to wonder why the best answer to varied requirements should come out so nearly uniform.

Actually, a good deal of the impressiveness of these super-plant buildings owes to endless repetition. Even an indifferent unit tends to acquire majesty when repeated often enough. Their weak points are usually the places where the repetition is deliberately broken for emphasis, as at entrances. And the auxiliary buildings associated with some of the giant production plants, as office buildings, powerhouses, and so forth, lack comparable scale and are therefore quite disappointing.

While it is true that many production activities are well, and flexibly, housed in uniform great halls of substantially similar appearance from Seattle to Charleston, still most industries have sufficient individuality in their processes, site or climatic conditions to justify design solutions that are not nearly so generalized and typical. The small architect, approaching industrial design of necessity with few preestablished notions, is quite likely to come out with designs adapted to particular sets of requirements, and diversified enough to be of value in keeping industrial design from freezing into a universal mold. Much of the progress in industrial design has been spurred on by the works of general practitioners, as the excellent Finnish plants of Aalto, the Van Nelle factory of Brinkman and van der Lugt, the mills of the Swedish cooperatives, the powerhouses of TVA, the chemical works of Alden Dow. Clients will be better served, and our civilization stands to be enriched if the sources of unorthodox creative contribution can be kept bubbling.

decisions, and predict human reactions — which are becoming more important to the success of industrial operations every year.

Specific instances of superior judgment exhibited by the architect are odious, and the writer hesitates to cite any. The practitioner new to this field will have

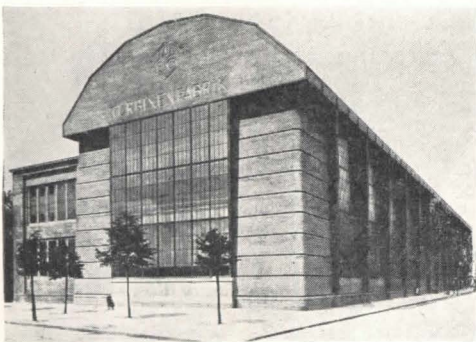

Turbine factory  
Berlin, Germany  
Peter Behrens  
architect (1909)



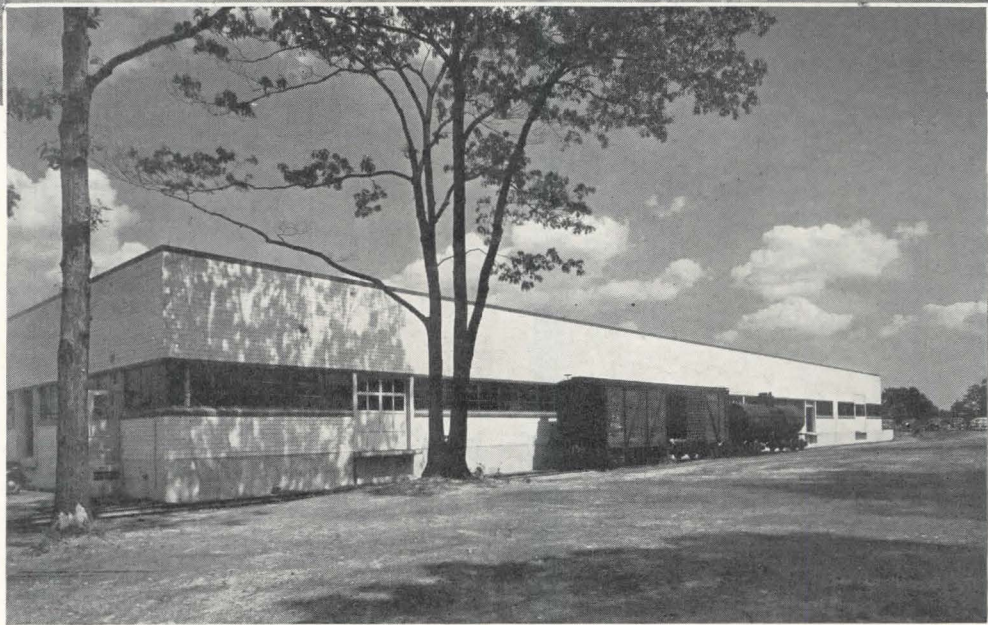
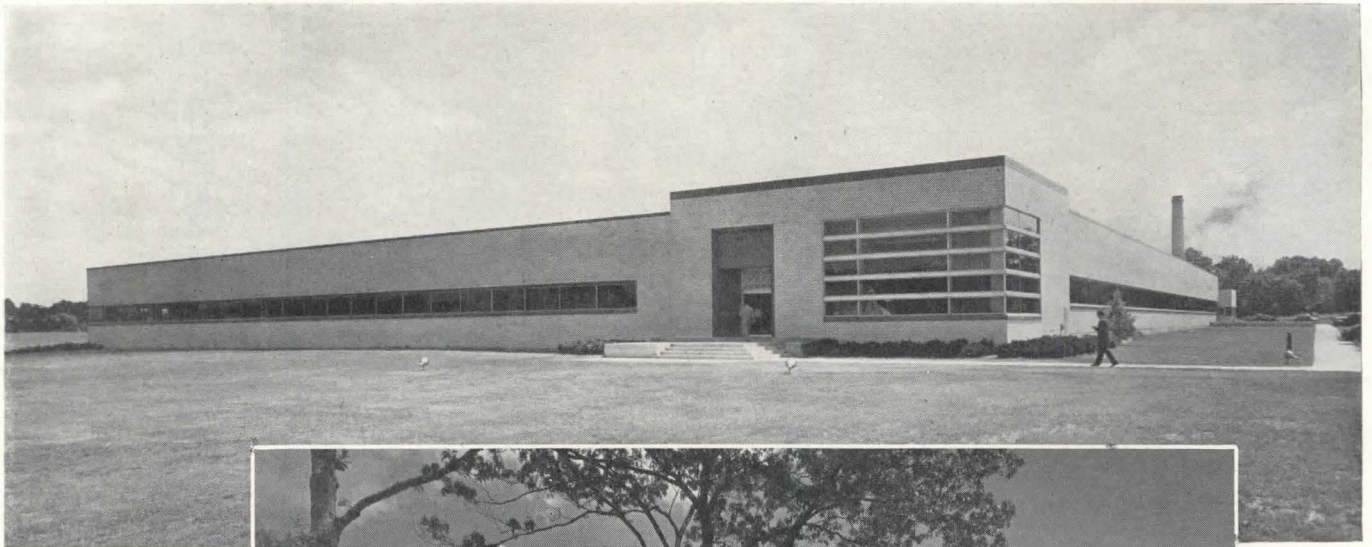

Ezra Stoller Photos

## NEWEST OF JOHNSON & JOHNSON FACTORIES

*Baby Products Plant, Cranford, N. J.; The Ballinger Company, Architects and Engineers; John A. Johnson and Sons, Brooklyn, General Contractors*

**I**N architectural literature the Johnson & Johnson plants are already well known. In industrial circles these factories are usually spoken of as "showplaces," but it is doubtful if this advertising word conveys much of their architectural significance.

It is certainly true that all of the Johnson & Johnson plants are deliberately designed to be "showplaces," for the company's sales policies embrace organized visits to the plants by various groups of doctors, nurses, editors and so on. But for all of the dolling up that this policy naturally involves, the Johnson concept of a factory has other facets.

One is consideration for employees, as this new plant proclaims with its own voice. Along functional lines,

there is also an intensive study of operational methods, leading to the latest in automatic processes and equipment and conveyors.

A recent publicity release states that this new factory "is expected to exemplify again the belief of General R. W. Johnson that a factory can represent the latest in functional efficiency and still retain its modern architectural beauty." If this particular release gets slightly mixed, at least there is evidence that the Johnson concept extends to a full appreciation of architectural values.

As for the showplace part, it dictated in large measure the plan of the plant. The "manufacturing area" on the plan is proportionately small. Actually this terminology



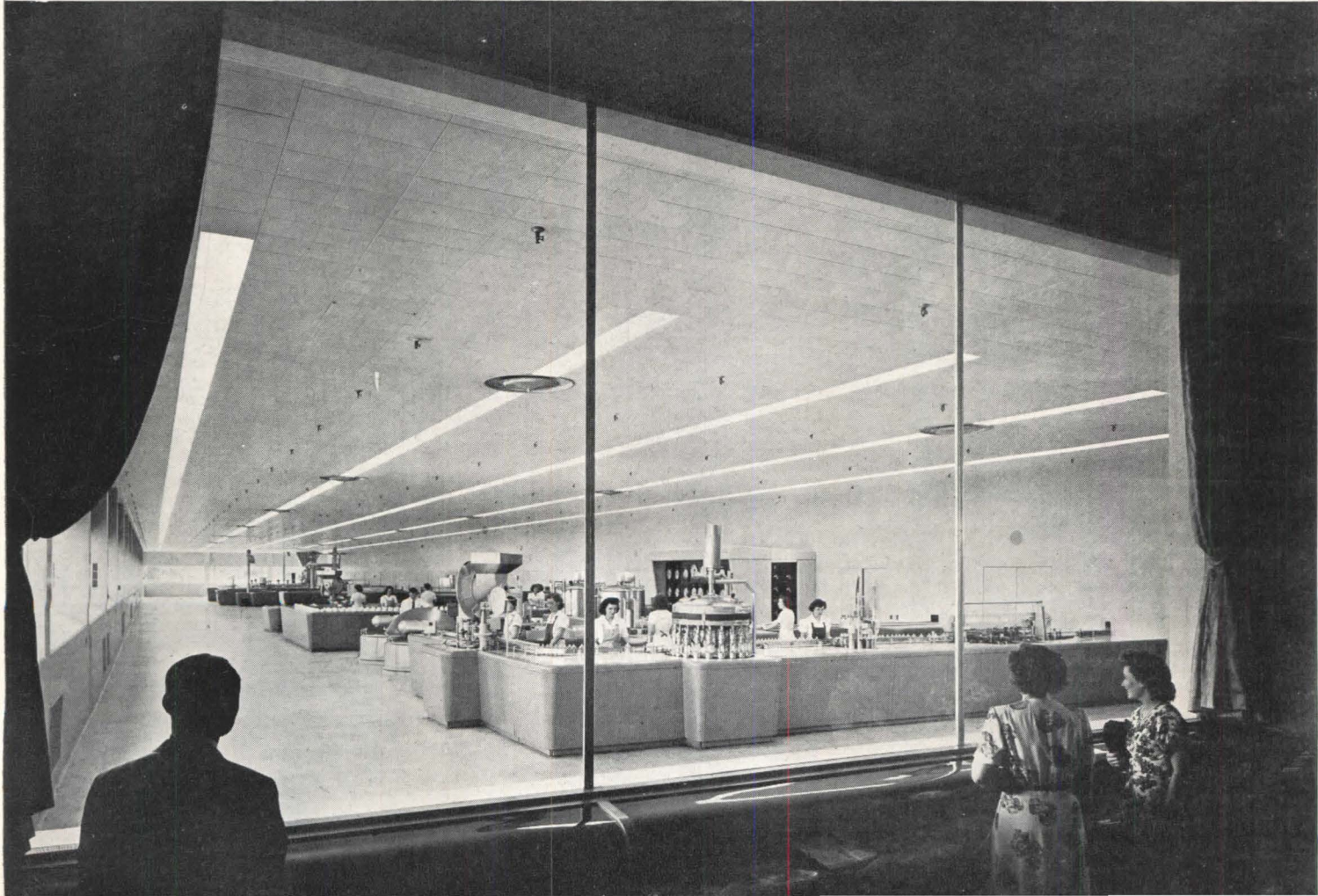



is literally correct, but there are any number of "warehousing" or pre-manufacturing processes not done here. In any case, the manufacturing area with its mixing and packaging lines is a "showplace," where the more interesting operations are made especially intriguing.

This exhibition technique explains the handsome modern lobby with its huge window looking into the manufacturing section. Here is an artful invitation to any visitor — even, or maybe especially, a prospective employee — to pause for edification.

As for employee relations, the lobby belongs as much to the workers as to the visitors. For the front entrance is the employees' entrance. This, too, is deliberate; the worker comes in the "front door" along with the works manager or any of his special guests. And perhaps if the worker is thus included in the family, it is not

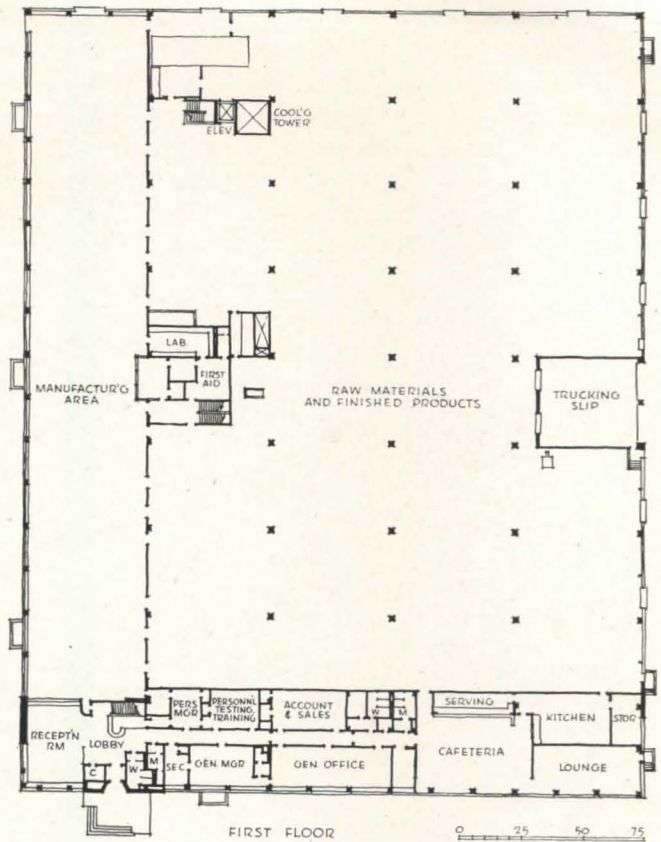
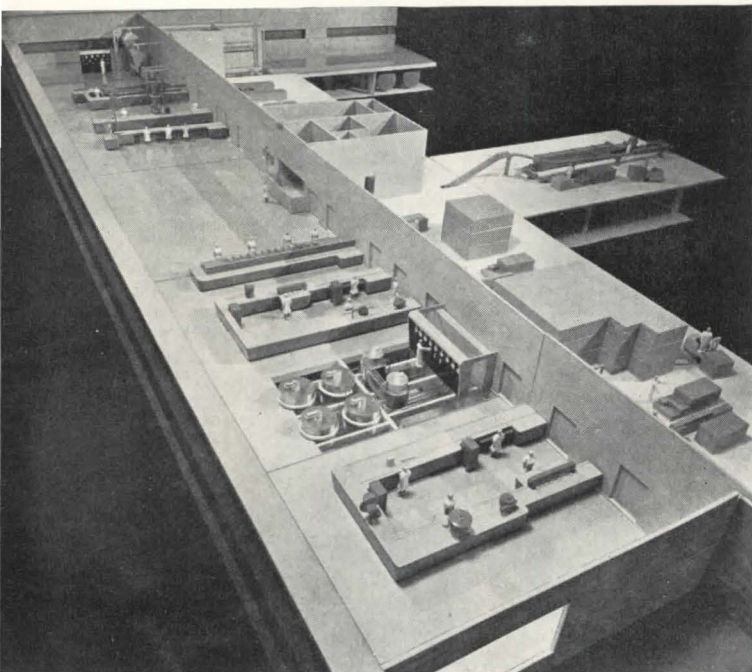

Detailed model of manufacturing area aided in locating assembly lines not only for efficient production but also for exhibition

only privilege but also responsibility that he shares.

From the lobby the employees go down the stairs to lockers and washrooms, come up via other stairs to their stations. Men and women workers follow entirely separate paths through the basement locker area, this being not so much a stipulation of management as a legal requirement in the New Jersey area.

Thoughtfulness toward employees put the cafeteria at the end of the office section on the ground floor. At one side of the cafeteria is an employees' lounge, with all the glamor of modern furniture and decor, and with club facilities, which extend even to a broadcasting booth where programs may be assisted with sound equipment, and from where music is piped through the plant during working hours. One reason for so placing the club and cafeteria facilities is so that this

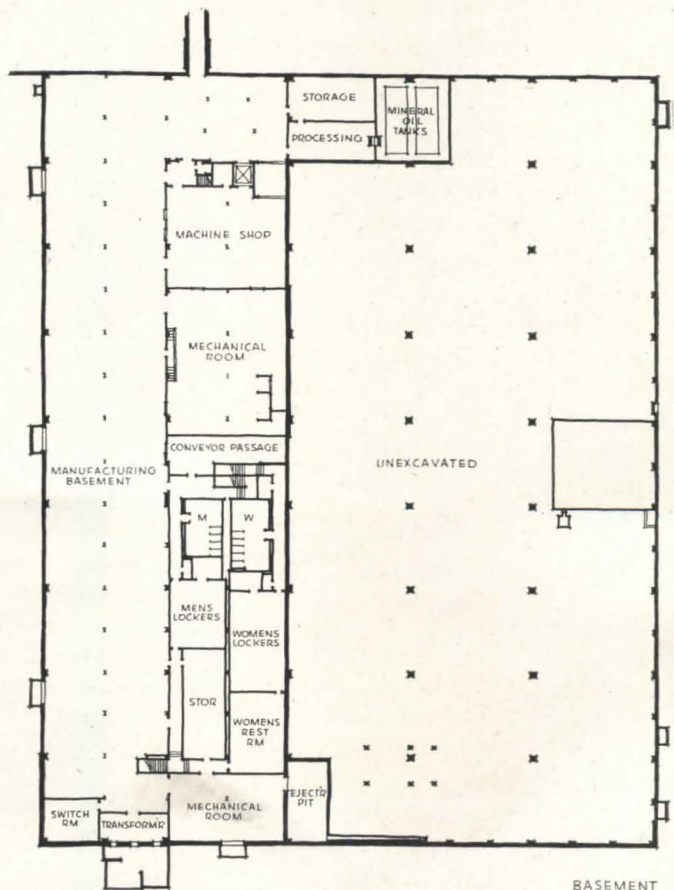



area may be separately opened for parties or meetings after hours.

In planning the manufacturing section, the company has availed itself of recommendation of experts in functional design, acoustics, lighting and psychology of color. Floors, walls and equipment are in colors known to minimize fatigue, eye-strain, and are conducive to efficient production. Herbert Rosengren,

industrial designer, was consultant on color schemes.

Site for the plant is a 30-acre tract at Cranford, N. J., and has been graded and landscaped. The building is but 250 by 315 ft., and is so placed that expansion can be made in any direction. With this in mind, the power station is in a separate building 180 ft. from the main building, so that this well-known block to expansion has been eliminated.



Above: spacious private office of the plant manager. Right: plant cafeteria, as seen from the broadcasting booth, whence restful music is piped to production areas, or speeches and music are "aired" for employee entertainment programs. Opposite page: the employees' lounge, which adjoins the cafeteria. The cafeteria and lounge facilities are so located as to be opened separately during evening hours for meetings or parties of workers. The same facilities may also be used for entertainment of groups invited to visit the plant

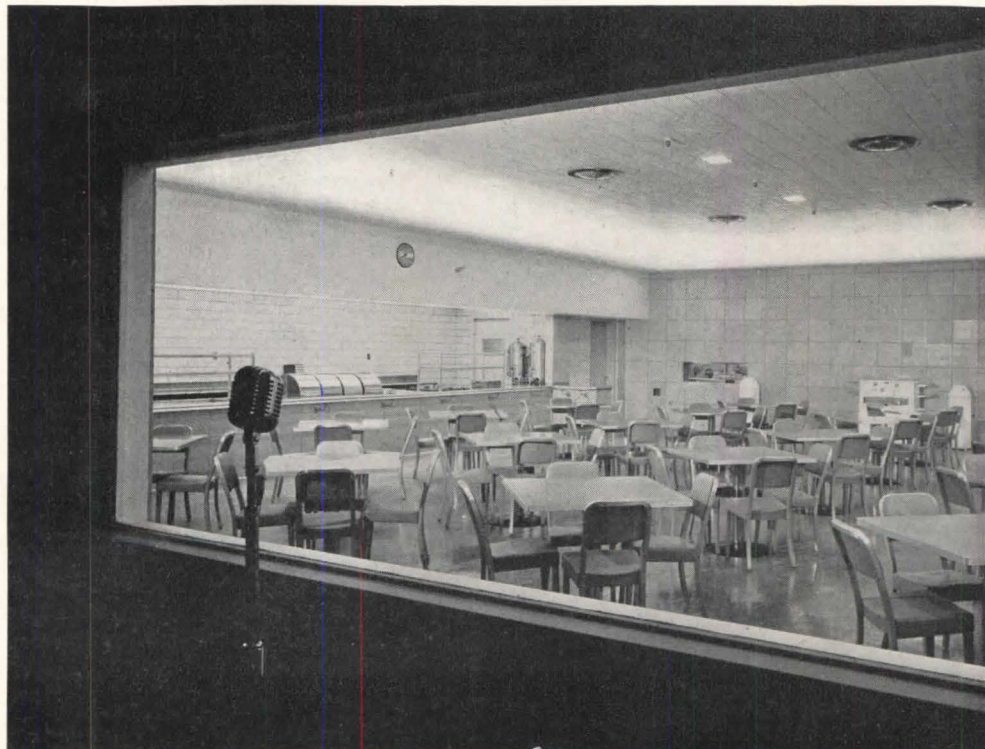









**MODERN PRESCRIPTION  
FOR INFANT INDUSTRY**

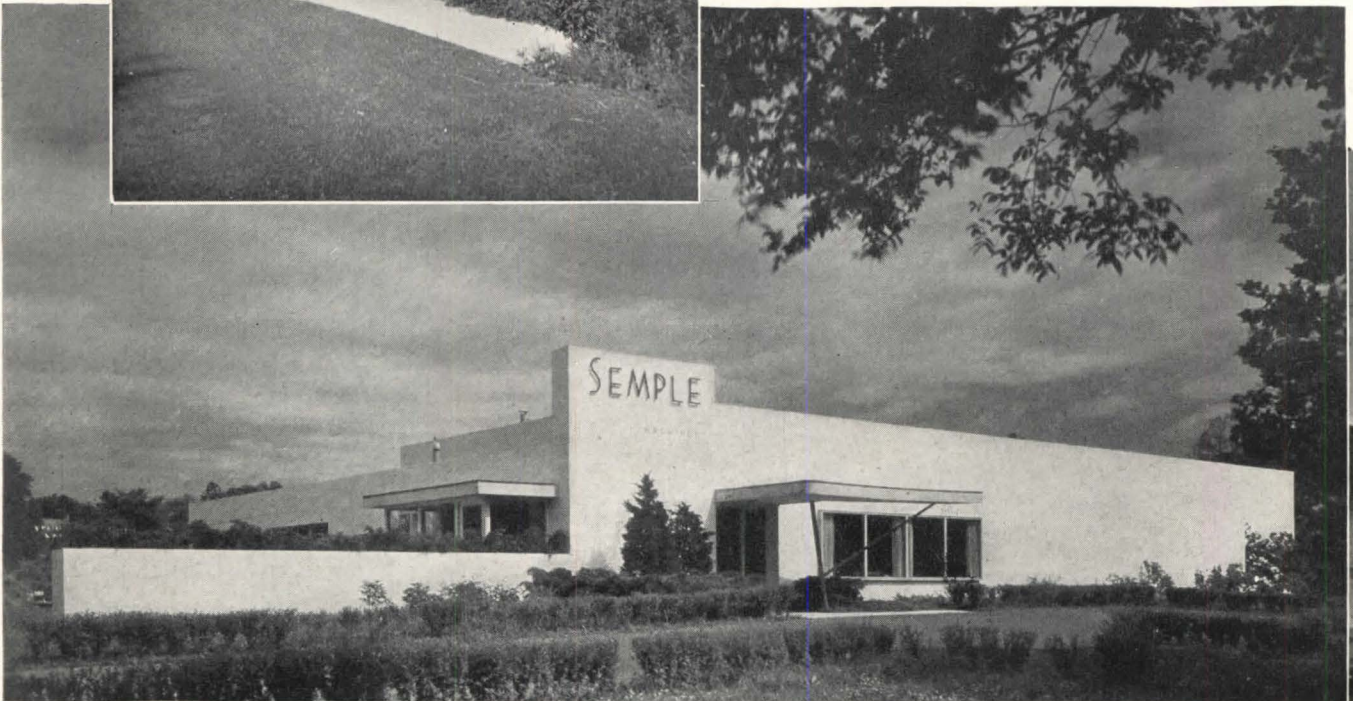

Piaget Photos

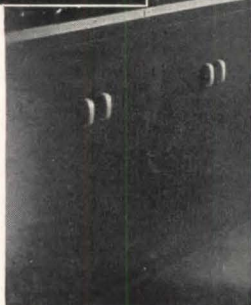
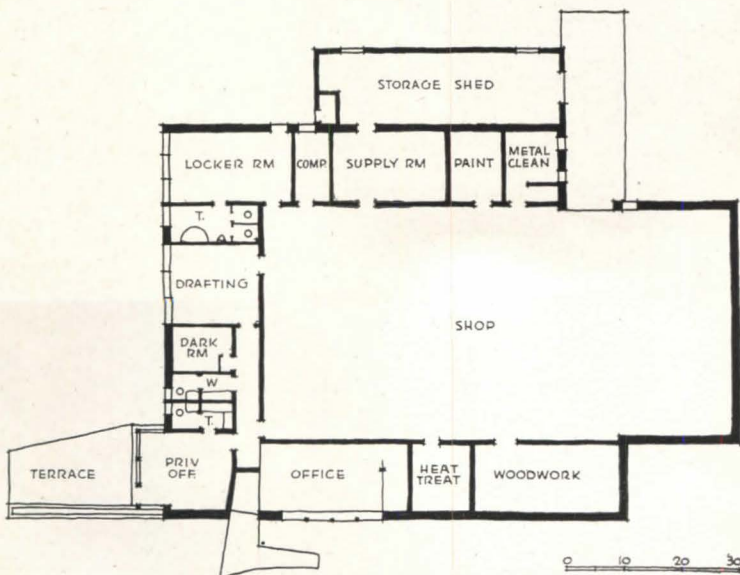



**T**HIS was just such an opportunity for the imaginative architect as Mr. Wank addresses himself to (page 86), the small industry bursting out of a backyard garage. Frederick Semple began riding his machine tool hobby in his mother's basement. With the war came requests for him to undertake special tool and instrument orders. Then came helpers, more machine tools in the garage, an enlargement of the basement, and finally the realization that here was a going industry, needing a factory building. This plant was hurriedly built as a war project, and has enabled the business to grow and en-

trench. Such an industry, moreover, gives an architect plenty of scope: there is no cut-and-dried formula. This plan is simple, and largely self-explanatory, except for the non-existent windows. The plant is windowless because Mr. Semple chose constant fluorescent light instead of varying sunlight, with its distribution problems. It was found also that the heat which would come in windows would cost more to remove by air conditioning than the cost of electric light. Outside walls are of double cinder block, with 3-in. air space between, filled with expanded mica insulation.

*Semple Machine Shop, near St. Louis*

*Harris Armstrong, Architect*

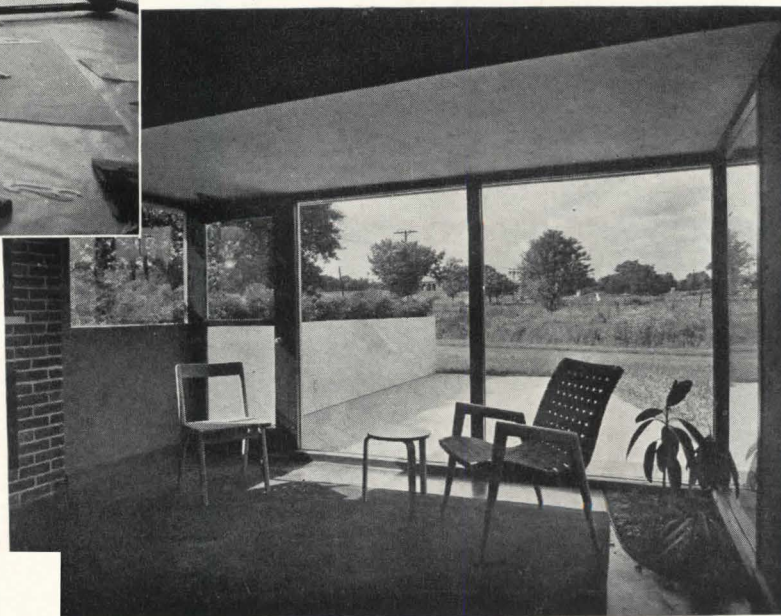
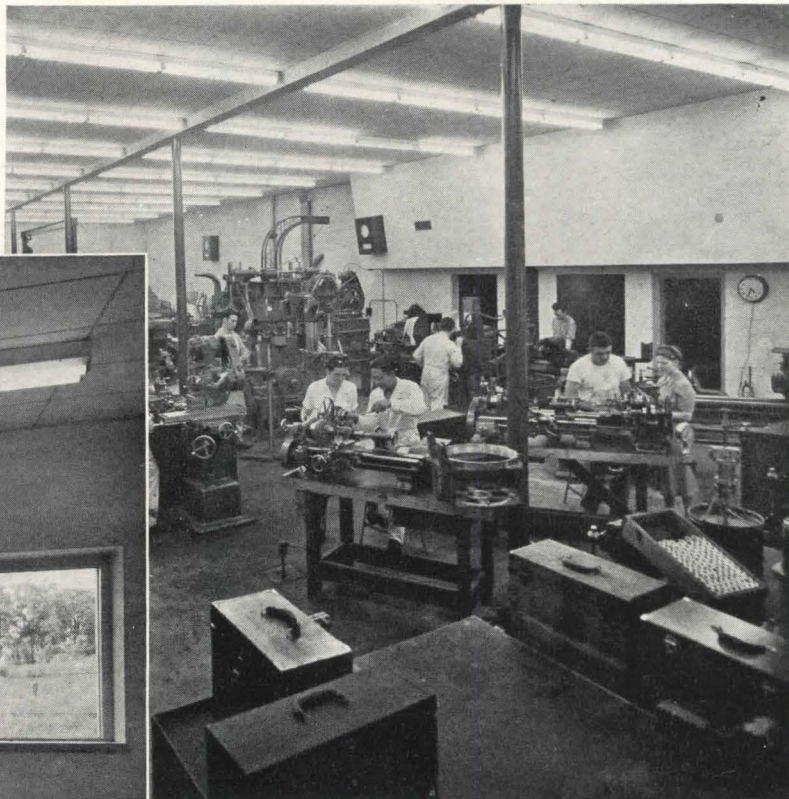



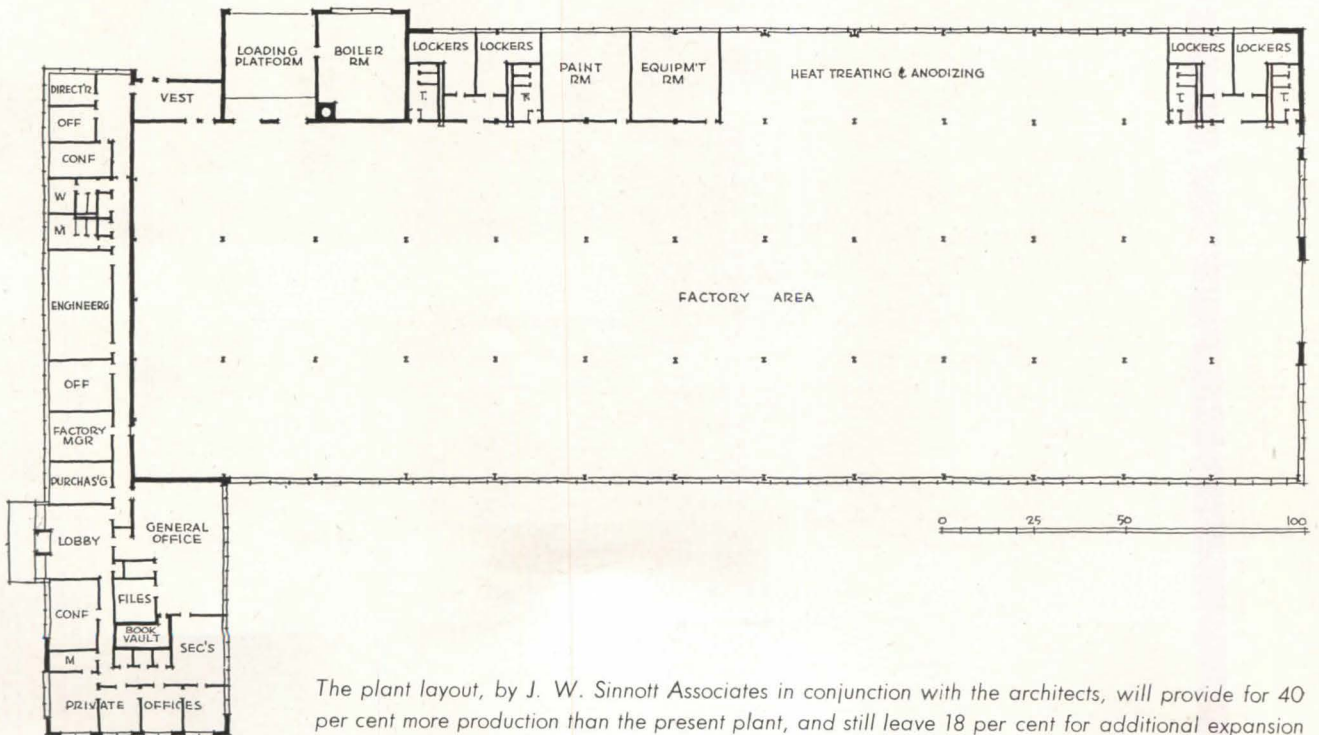
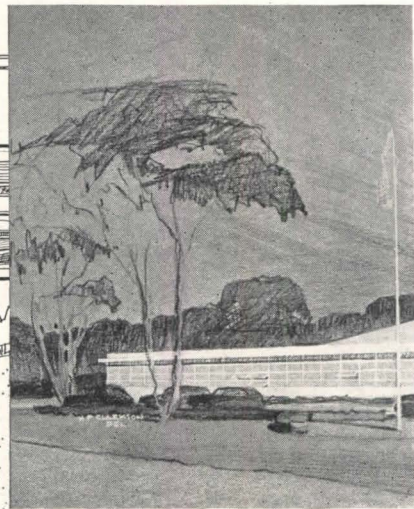
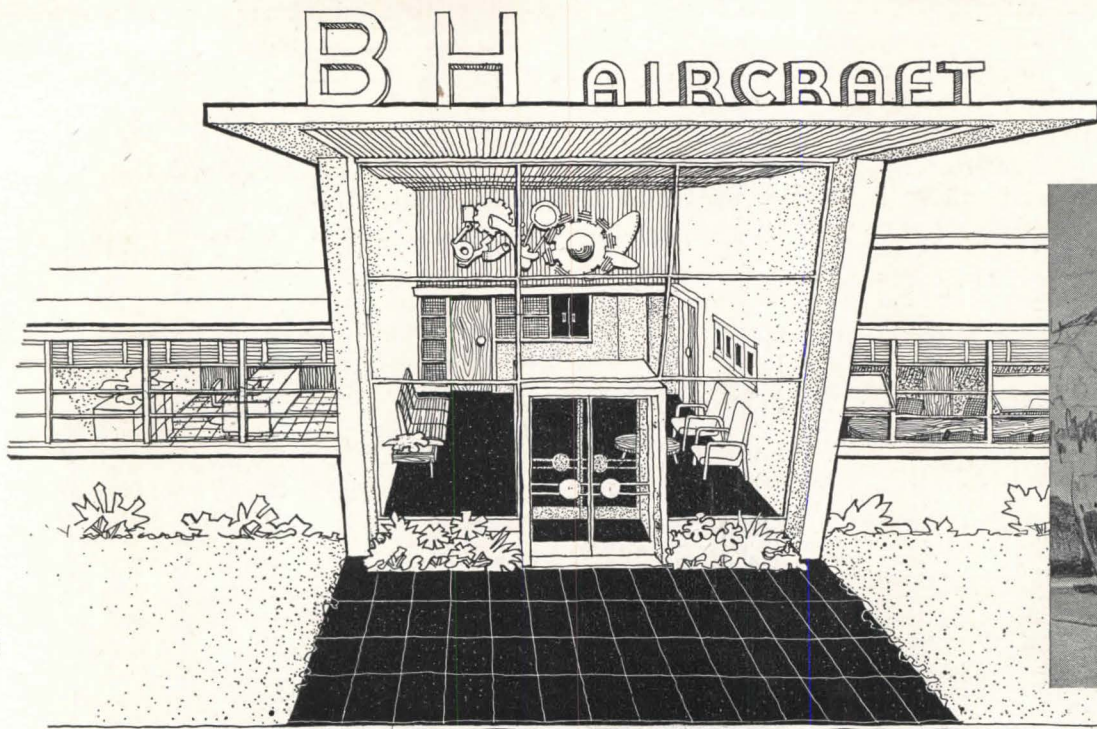

The plant layout, by J. W. Sinnott Associates in conjunction with the architects, will provide for 40 per cent more production than the present plant, and still leave 18 per cent for additional expansion within the shell. Further expansion is easily possible by extending the building by repetition of original bay design. Parking will increase parallel with the building, and in direct proportion to increase in labor force. The column spacing of 25 by 33 ft. was chosen for this particular operation, which must accommodate small private planes within the plant. The plan also provides good circulation



# ECONOMICAL DESIGN RETAINS AMENITY VALUES

*B H Aircraft Plant, Islip, L. I.; Petroff and Clarkson, Architects;*

*Robert H. Edwards, Associate Architect*

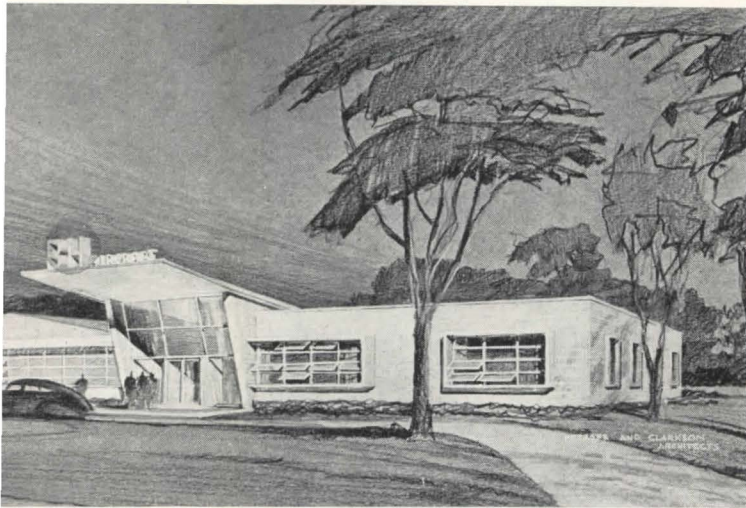

**A**FTER years of operation making aircraft sub-assemblies, this industry needed a new plant, for typical reasons: inefficient column spacing and equipment layout, congestion in loading, shipping, parking, multi-floor operation, and general inefficiency. Management also wanted better labor amenities, and improved appearance. Thus high building costs were less of a factor than high production costs. Nevertheless the design of the new plant is economical in several respects. The building contains 47,600 sq. ft., and estimated cost, exclusive of equipment and design fees, is \$286,552, or \$6.00 a sq. ft. The design calls for concrete block construction, waterproof paint treated inside and out, steel windows, steel column, joist and roof deck construction, on concrete footings, foundations and slab on earth. Corrugated glass panels built into the roof construction will provide maximum daylight and a uniform lighting curve through the plant cross section.

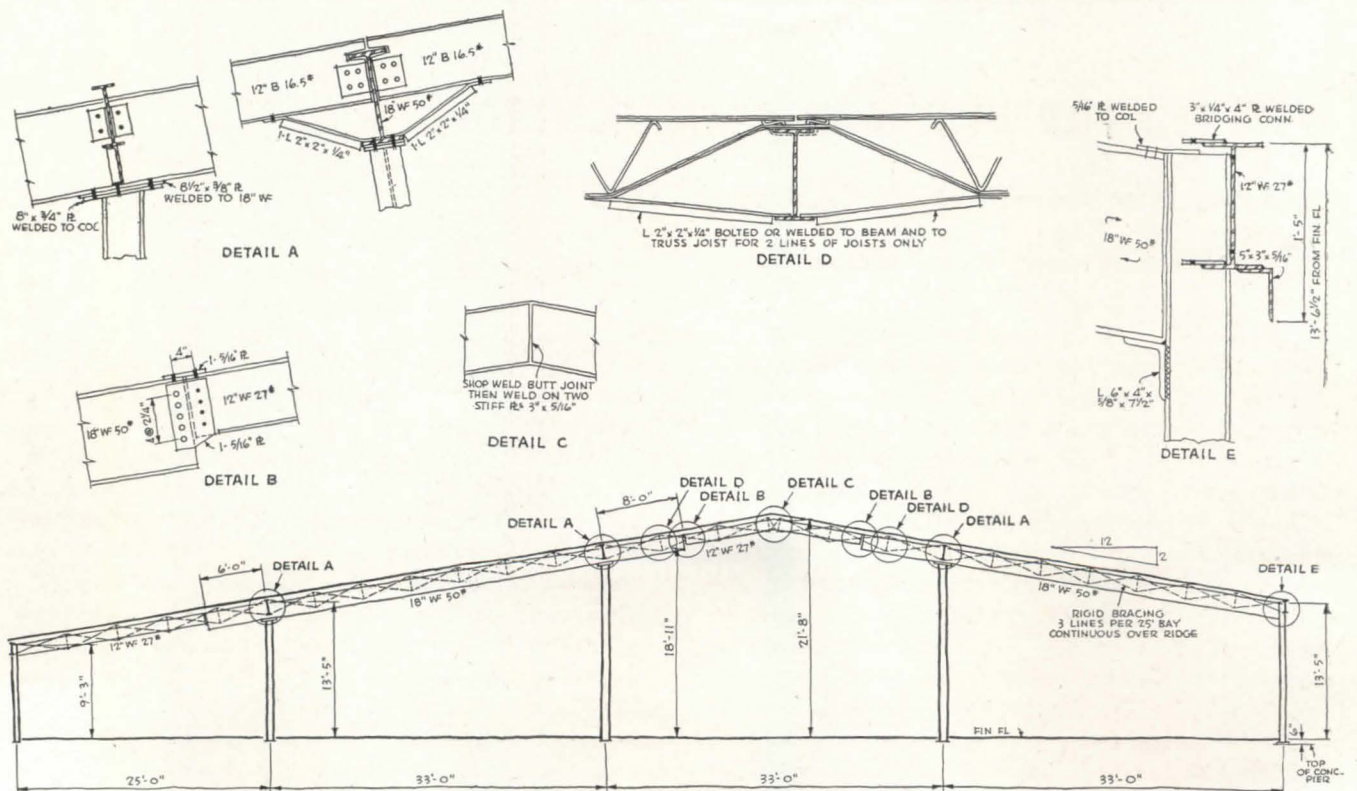

The structural steel design is unusually economical, requiring only 6.00 lb. of steel per sq. ft. The central span girders are cantilevered over the interior columns. Beyond the cantilever, both at the side and in the center, the steel is lightened



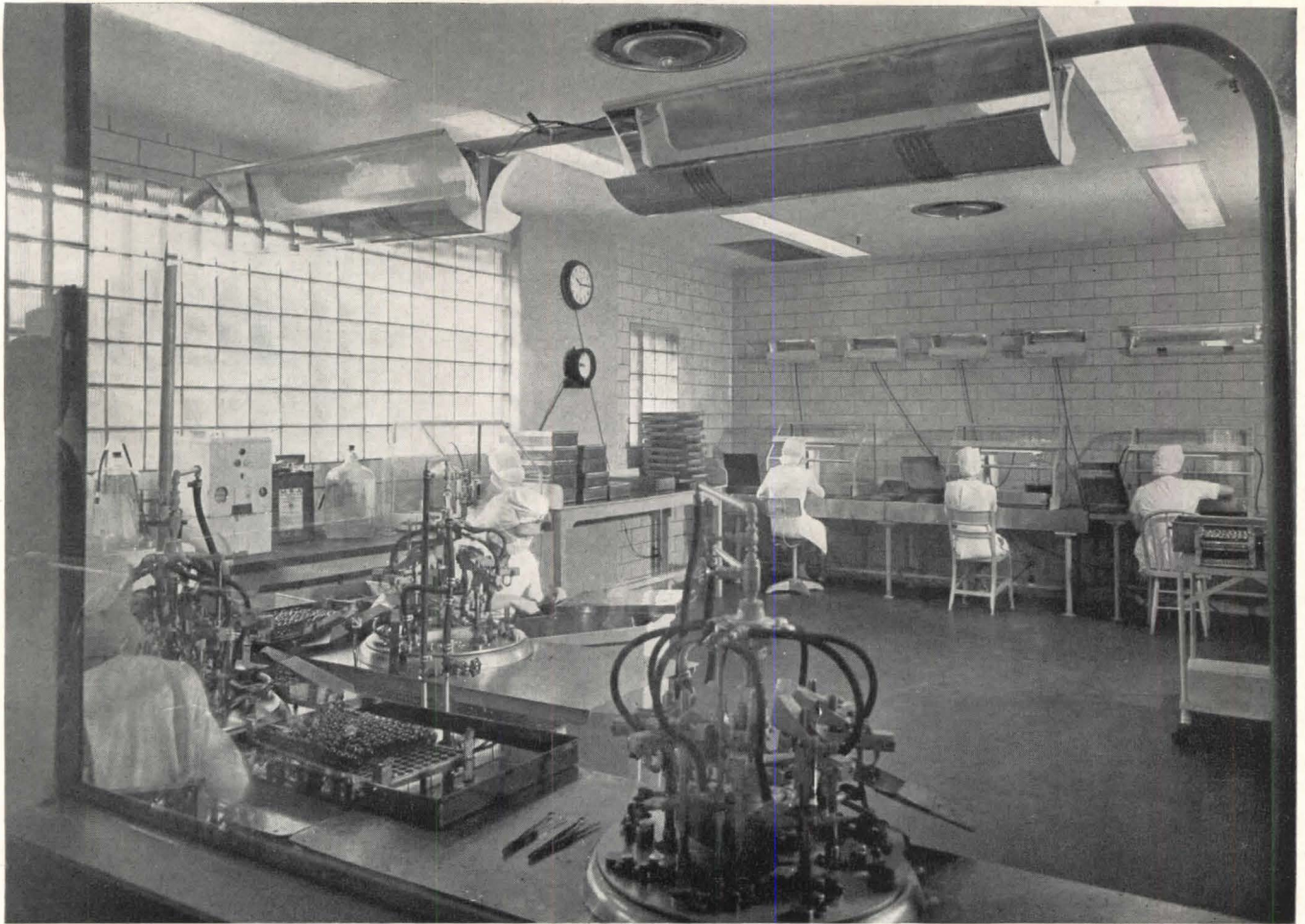

## DESIGNED FOR DUST AND GERM CONTROL

*Ampul Building for Winthrop Chemical Co., Rensselaer, N. Y.*

*The Austin Company, Engineers and Builders*

**D**ESIGNED for the production of pharmaceutical products, this building imposed extreme requirements for control of dust, germs, temperature, humidity, also for protection of employees against poisons used in certain departments.

The first requirement for the building was to seal it completely. Next was virtually to eliminate dust. The building, a reinforced concrete structure, has specially-insulated brick sidewalls, constructed with a vapor barrier, and smooth glazed tile throughout the interior, where corners, ledges, and other dust-collecting spots have been virtually eliminated. With glass block in place of windows, and generous areas of sash in steel partitions, it has been possible to provide excellent distribution of daylight and still prevent infiltration of dust or moisture.

Suspended ceilings on the first, second and third floors are completely flush, and are treated with a special kind of non-flaking plaster. Fluorescent lighting

is recessed in glass-enclosed fixtures, and all piping is concealed above the suspended ceiling. All floors are covered with linoleum.

All employees enter the building through the first floor lobby, and go directly to the basement to the locker rooms, where they change to uniforms and pass through a dedusting machine, which removes all loose particles of dust, lint and hair, and then proceed to the various departments on all three floors. This same procedure is followed whenever the employees leave their departments to go out of the building. Visitors likewise will enter through the main lobby to a visitors' room in the basement, where they will be supplied with

*Above: sterile lamps in a drug-making department. Opposite page, top: in corridors everything is flush, to obviate dust collection. Right: exterior walls, with vapor barrier and glass block, are virtually sealed. Far right: the "de-dusting" passage*



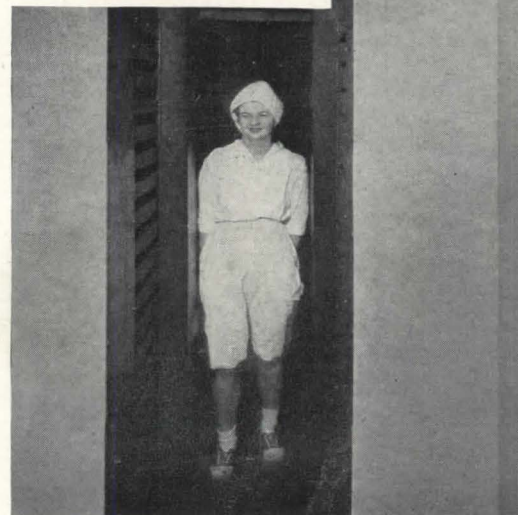
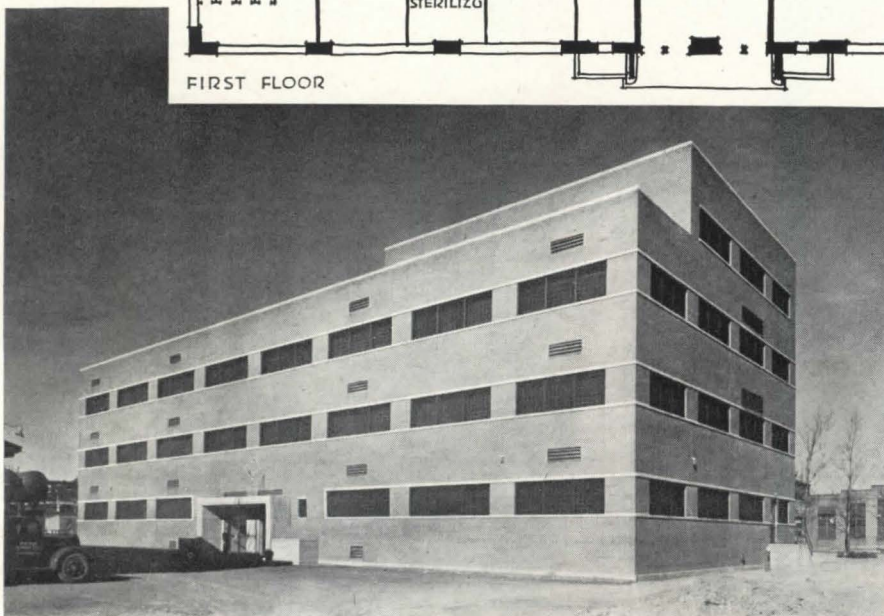
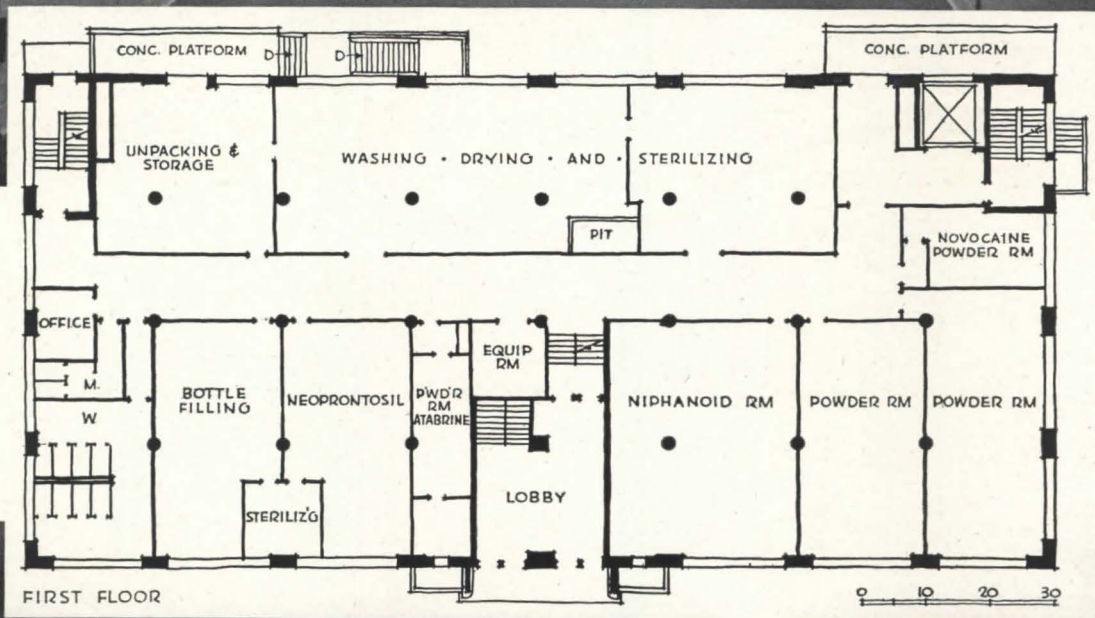
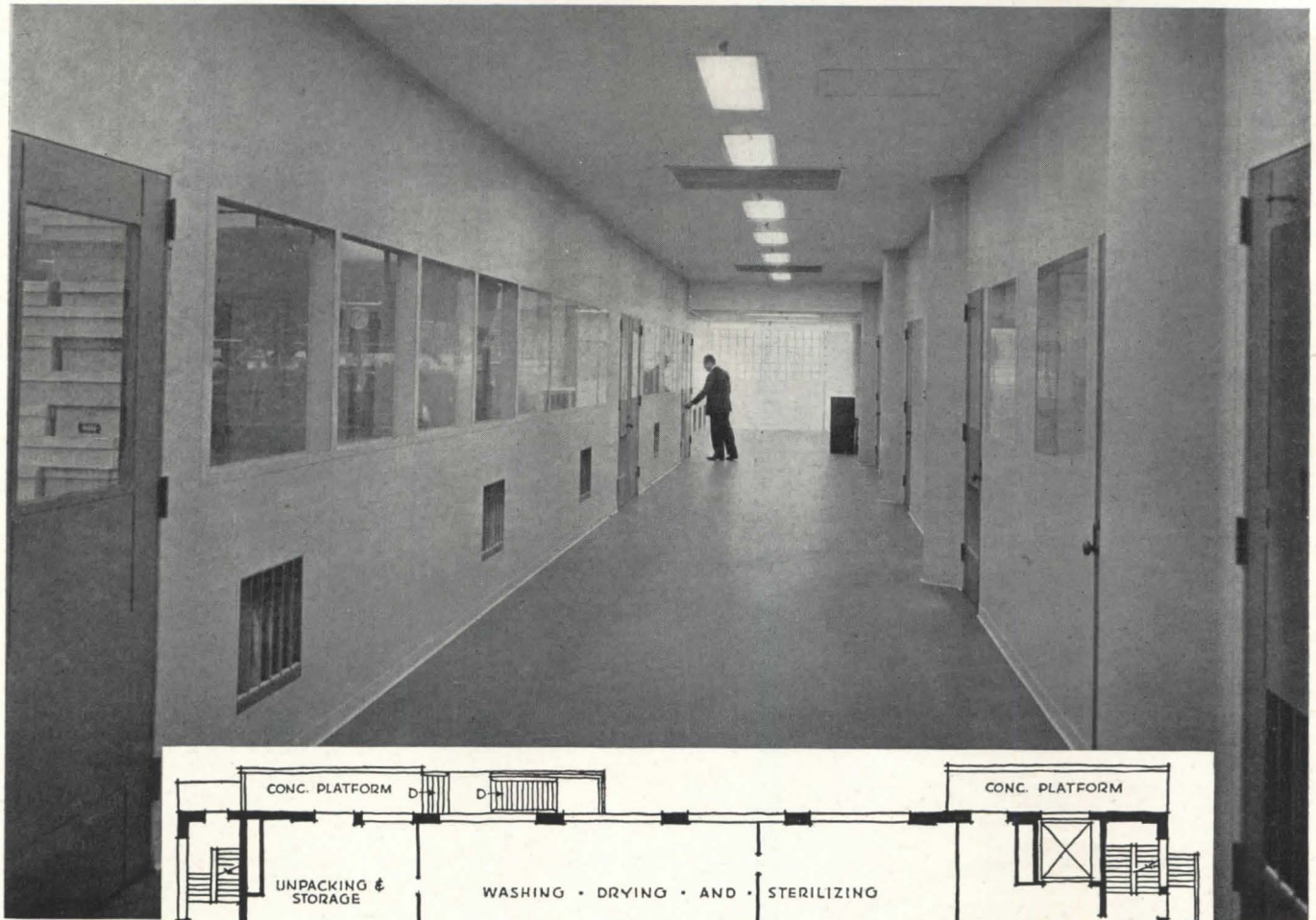



special clothing, and then will pass through the de-dusters, like the employees, before inspecting the various departments.

Each department is zoned separately for air conditioning, each with its own controls. Humidity control is an especial requirement in certain departments. Sterile lamps are installed at two places in the main

supply ducts on each floor. All outside air is first filtered through throw-away filters, and then, before being distributed, is again filtered electrostatically. Supply ducts are concealed in suspended ceilings; the corridors themselves are used for returns. A complete system of central vacuum cleaning equipment has been provided, with outlets available to all parts of the building.

*Below: immaculate conditions must be maintained where ampuls, vials and bottles are washed. Bottom, left: air washers and refrigerating compressors. Bottom, right: control center for compressors, dust-collecting and vacuum*

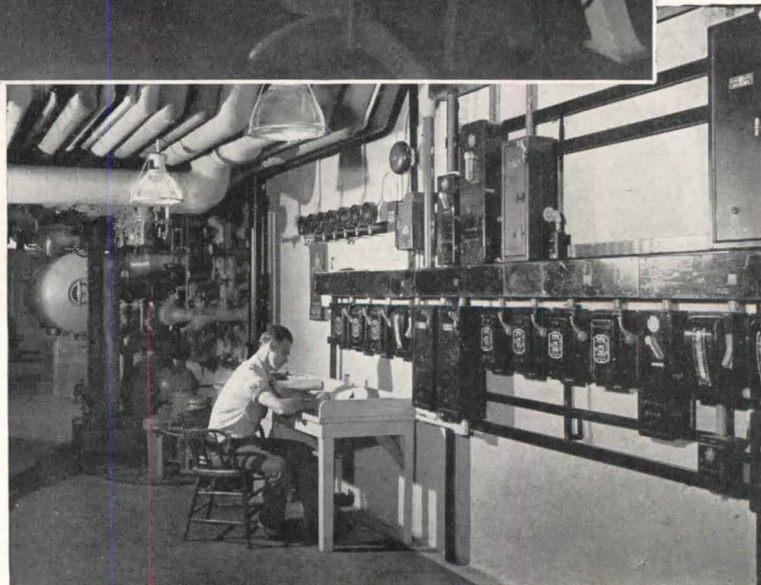
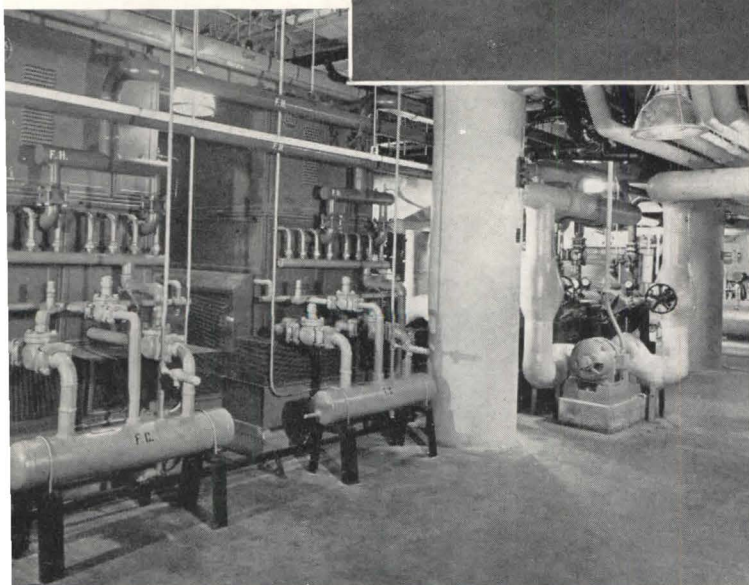
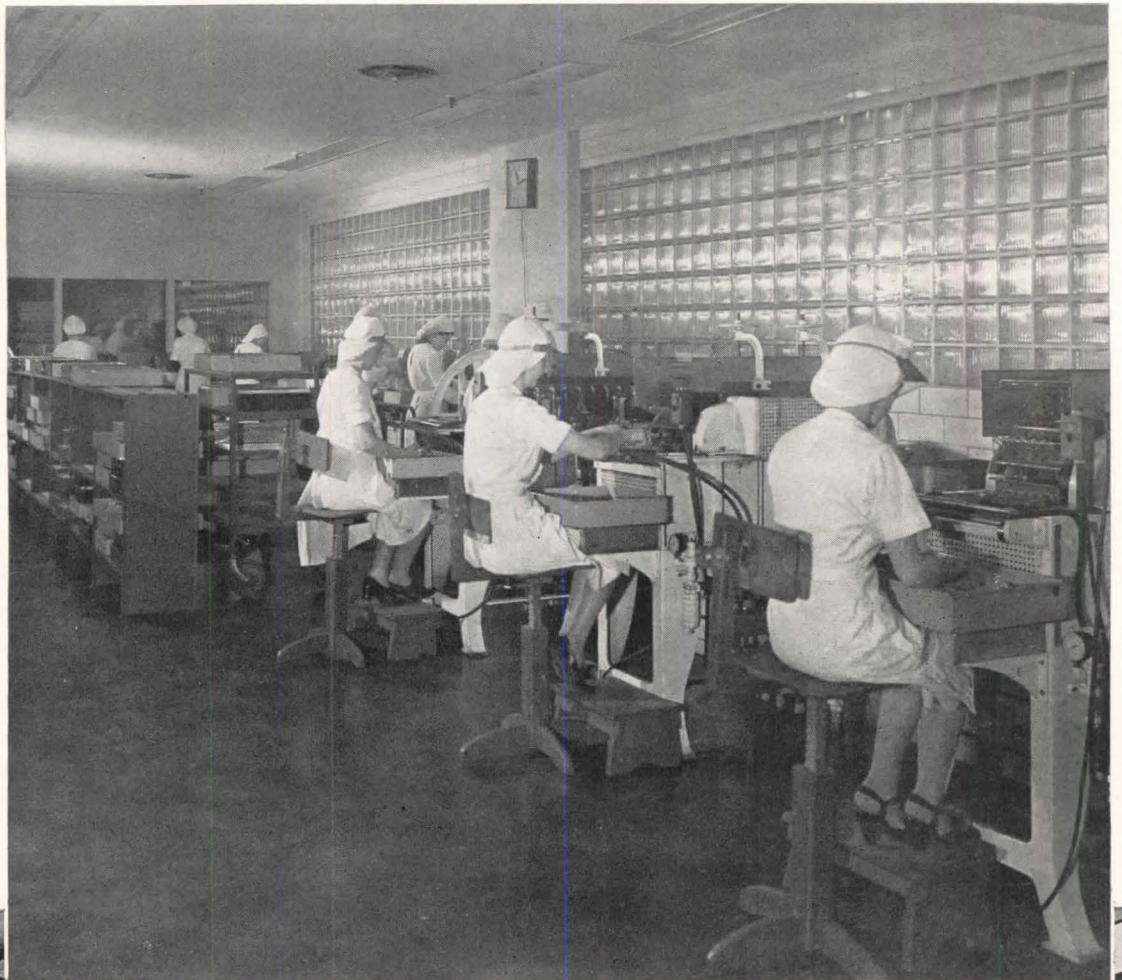



# ARCHITECTURAL ENGINEERING

TECHNICAL NEWS AND RESEARCH

## INDUSTRIAL PLANTS—A HARVARD RESEARCH PROJECT

By Walter F. Bogner, Professor of Architecture, Harvard University

INDUSTRIAL buildings are governed in their form and construction primarily by efficiency. A compact and convenient plant layout reduces the manufacturer's production costs; economy in building expense cuts down his overhead. Industrial buildings are likely to run into large areas, and the fluctuations in price per square foot can be great due to the large variety in building methods and types of mechanical installations at the disposal of the designer. In the interest of efficiency the need for an analysis into the kinds of materials, the systems of framing, and the types of installations to be used in the construction is therefore indicated.

An industrial plant analysis was undertaken by a group of my students at the Harvard School of Design, from which the illustrations accompanying this text resulted.

The charts and drawings are by no means complete, nor, I am afraid, are they accurate in every detail. They deal only with the factors which influence the building above ground. Foundations are not included, nor have the installations for power, light, heat, ventilation, fire protection, and other miscellaneous piping been adequately taken into account. They are student studies, prepared in a short time by men who have not yet had practical experience and who had only their instructors, the library, and a few materials dealers for guidance and help. The analysis must therefore be taken as an indication of a method of approach and not as a compendium of charts and tables of concise facts and figures. The irksome inaccuracies which may come to light in this publication only emphasize the great need for documented information permitting a comparison of materials and methods of construction on a uniform and unbiased basis.

Three factors were taken into consideration as determinants for the efficiency of construction methods and materials: first, the economic factors, comprising initial cost, upkeep, and operating cost as influenced by heat losses; second, the installation of the

materials in the interest of demountability, which affects the cost of plant expansion; third, the functional properties of the various types of construction. The last-named covered the factors which cannot be evaluated on a dollars-and-cents basis, like acoustic properties, appearance, and the resistance of the material to weather and hard usage.

The cost figures have been based on data for the Boston area compiled and published by R. S. Means in a booklet entitled, "Building Construction Cost Data, 1945." Wherever his figures were incomplete, they were augmented by prices obtained from salesmen. The studies were made while many of the materials were not in production and while an erratic rise in building costs was in progress.

The charts for wall, floor, and roof construction were prepared to facilitate the selection of the most suitable building method for specific plant needs. They include more inexpensive building methods than elaborate ones. The framing analysis was worked out to aid in the determination of column spacing.

The required pounds of steel per square foot are given for different bay sizes and roof loads as indication of relative costs. Diagrams of the mechanical plant consisting of lighting, heating, ventilation, and piping distribution were also prepared to indicate the diverse methods of installation available and to consider their relative merits.

In the construction analysis all of the 18 students in my studio participated, each investigating and drawing up a part, and all working together in the interest of obtaining as complete a picture of the problems arising in the building of industrial plants as the time and other limitations permitted. The uniformity of the presentation was largely due to E. N. Turano's efforts and organizational ability.

The analysis was applied by the students to a specific type of industrial building for which they had developed designs: a plant for the production of hand tools. These student designs paid particular attention to the provision of optimum working conditions, workers' comfort and recreation (p. 112).

Photo by Paul Southwick, Harvard Univ. News Office



Typical scene during a conference and judgment of student work, when student peers join with professors in a session of criticism and defense. At the right, Prof. Bogner; at the left, seated, are Prof. Walter Gropius and Dr. Metcalf, Director of Widener Library



# WALL CONSTRUCTION ANALYSIS

TYPE		ECONOMIC					INSTALLATION				FUNCTIONAL							
MATERIAL		COST/SQ.FT.		WT./SQ.F	HEAT CONDUCT.	MAINT	FIRE RESIST.	SALV.	METHOD OF ATTACH.	GAUGE THICK.	WEATHER RESIST.	ACOUSTIC	LOAD BEARING	GENERAL DURABIL.	REMARKS			
		MAT.	LABOR															
MASONRY	①	BRICK CAVITY WALL FOAM GLASS CORE		89	42	81.75	36	NONE	4 HR	10%	MASONRY CONST	9"	EXCEL	POOR	NON	EXCEL	GOOD APPEARANCE, PLEASANT NATURAL COLOR	
	②	CONCRETE BLOCKS		20	12	49	40	RE-POINT JOINTS	4HR D-2	30%	MORTAR	8"	100%	FAIR	700 PSI	INDEFINITE	UNIT SIZE 8"x8"x16"	
	③	GINDER BLOCKS		216	13	45	30			B-4		MORTAR	12"		GOOD	450 PSI		UNIT SIZE 8"x12"x16"
	④	GUNITE (STEEL FRAME)		65	25	18	0.84	EXPANS JOINTS	3 HR	POOR		2 x 2 MESH ON VERTICAL CHAN'LS	3"	EXCEL. BMS94 '42	POOR	NON	EXCEL BMS94 '42	ARCHITECTURAL APPEARANCE EXCELLANT NO FORMS OR HEAVY LIFTS FOR CONCRETE
	⑤	GUNITE (T.C. BACKING)		27	27	30	52	EXPANS JOINTS	3 HR	POOR		2 x 2 MESH ON BONDED CHAN'LS	5-1/2"	EXCEL BMS94 '42	GOOD	LIGHT- 1 STORY	EXCEL BMS94 '42	LIGHT WEIGHT OF 4 - GOOD FOR SPANDRELS 5 SELF-SUPPORTING - NOISE RESISTANT
PANEL CONSTRUCTION	⑥	CEMESTO BOARD		35	.20	4 5.3	25 15	NONE	2 HR	100%	BOLTED TO STEEL GIRTS	1-1/8"	EXCEL	GOOD	NON	EXCEL	SMOOTH SURFACE, PANELS 4X8', BATTENS AT JOINTS	
	⑦	CORRUGATED TRANSITE		274	136	542	28	NONE	NON-COMBUST	100%	BOLT & CLIP TO STEEL FRAME	7/16"	EXCEL	FAIR	NON	INDEFINITE	LIGHT GREY COLOR, SMOOTH, DULL, UNIFORM FINISH CAN BE PAINTED DRY WALL CONSTRUCTION	
	⑧	FLAT TRANSITE		424	186	292	28	NONE	NON-COMBUST	100%	BOLT & CLIP TO STEEL FRAME	1/8"	EXCEL	POOR	NON	INDEFINITE	LIGHT GREY COLOR, SMOOTH, DULL, UNIFORM FINISH BRITTLE CAN BE PAINTED DRY WALL CONST	
	⑨	ROBERTSON SINGLE "Q" UNIT		1.25	.25	5.3 12.3	11 1/2 - 0.14 2 - 0.115	NONE	2 HR	100%	RH BOLTS TO GIRTS 12" OC. WELD AT BOTTOM	BACK 10-16 FRONT 12-20	100% MOISTURE BARRIER	POOR	LOAD BEARING	INDEFINITE	GOOD ARCHITECTURAL APPEARANCE-EXTERIOR & INTERIOR FINISH - FLUTED OR FLAT - ERECTION 34	
	⑩	ROBERTSON 2 CELL "Q" UNIT		1.25	.25	13.5	2 1/2 0.98	NONE	2 HR	100%	ANGLES 12" OC - OR RIVET CLIPS TO GIRT	12-20	INSIDE & OUTSIDE	FAIR	UP TO 2 STORIES	INDEFINITE	TO 50 SQ FT/MIN FINISH BLACK OR GRAY BAKED ENAMEL - LENGTHS FROM 12'-0" TO 25'-0"	
	⑪	ROBERTSON V-BEAM GALBESTOS		28	22	3	u . 85	NONE	NON-COMBUST	100%	STRAPPED TO GIRTS	20	EXCEL	POOR	NON	30 YRS.	CLEAN, INDUSTRIAL APPEARANCE, QUICK ERECTION ASPHALT-IMPREGNATED ASBESTOS FELT OVER METAL	
	⑫	ROBERTSON INSULATED GALBESTOS		50	30	6	k . 16	NONE	NON-COMBUST	100%	T-BARS & GIRTS	22	EXCEL	GOOD	NON	30 YRS.	COMES V-BEAM, MANSARD, OR CORRUGATED IN BLACK, MAROON, OR ALUMINUM FINISH	

## FLOOR CONSTRUCTION ANALYSIS

①	CONCRETE, INTEGRAL WEARING SURFACE	02	07	72	66	WASH	NON-COMBUS	NONE	INTEGRAL	1/2"	EXCEL	POOR	500 PSI	GOOD	BRITTLE, MOST DIFFICULT TO REPAIR, STAND TYPE CONST, LOWEST MAINT COST
②	WOOD BLOCK	42	08	10.5	15	OIL	FIRE RESIST.	100%	SET IN TAR, PITCH, ASPHALT, OR MORTAR	3/2"	GOOD	FAIR	5000 PSI	GOOD	EASY TO REPAIR, MORE RESILIENT, QUIETER, WARMER, THAN OTHER TYPES
③	BITUMINOUS MACADAM	12	.06	24	40	WASH	FIRE RESIST.	NONE	INTEGRAL	2"	WATER-PROOF	POOR	90 PSI	FAIR	ACID RESISTANT

*Illustrations and tables on this and following pages are intended to show only a method of student analysis and presentation; see page 103 for explanation*

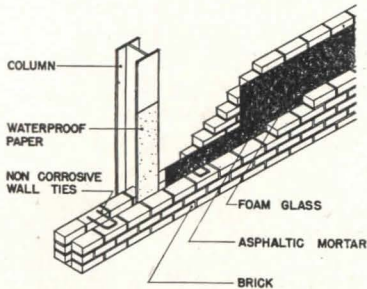

①

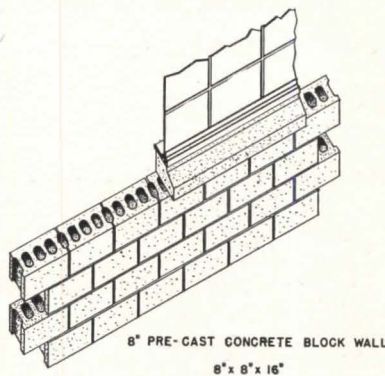

②

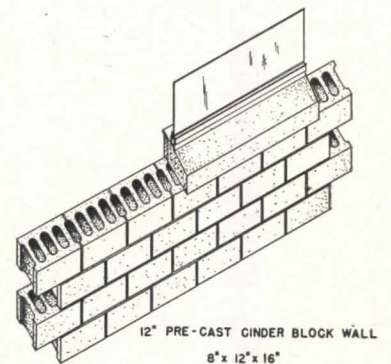

③

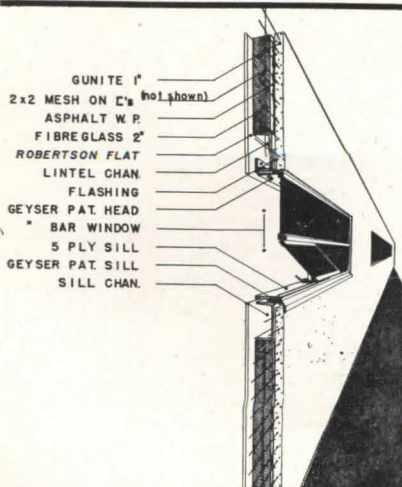

④

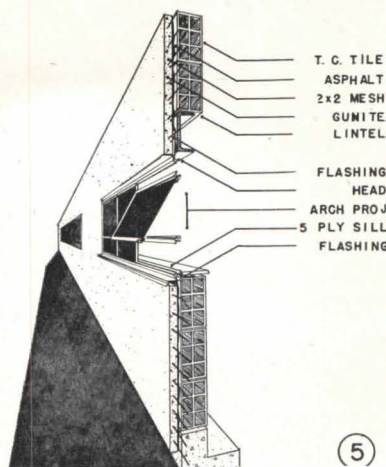

⑤

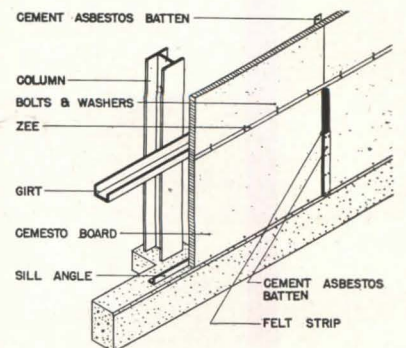

⑥



**CORRUGATED TRANSITE**

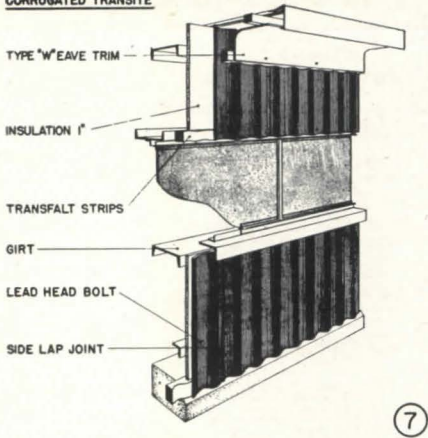

7

**FLAT TRANSITE**

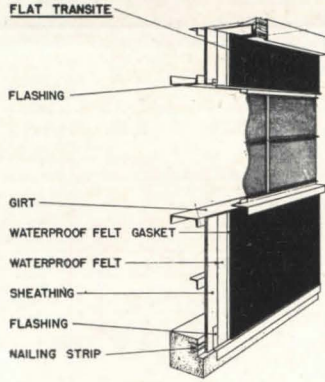

8

**ROBERTSON SINGLE 'O' UNIT**

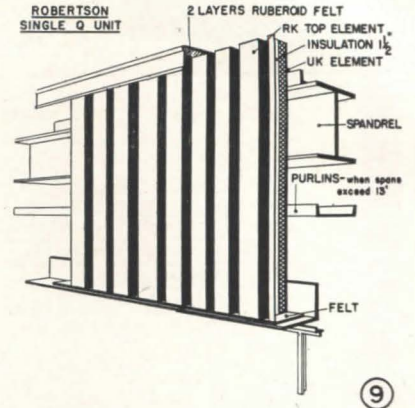

9

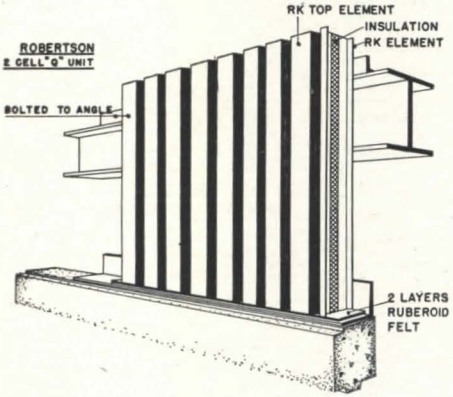

10

**GALBESTOS**

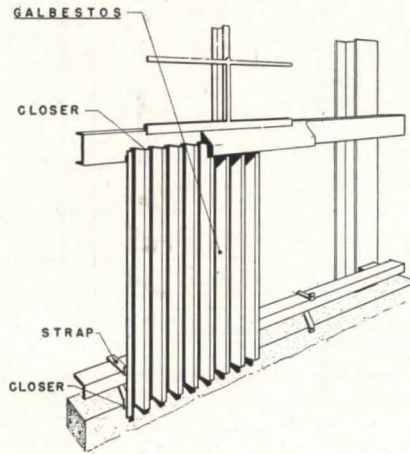

11

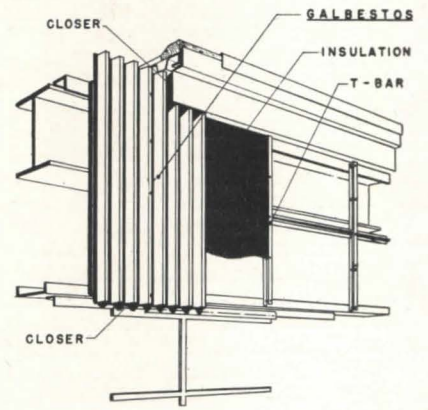

12

# FLOOR CONSTRUCTION

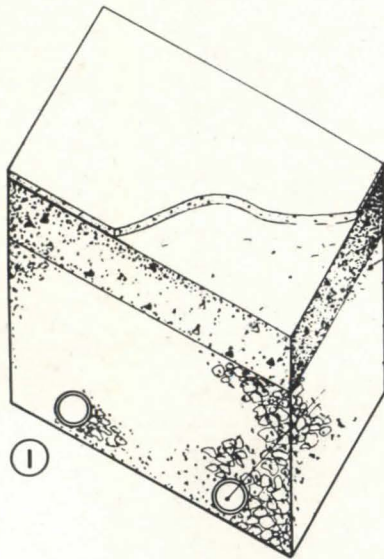

1

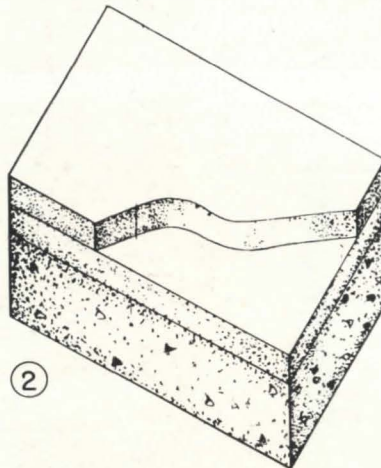

2

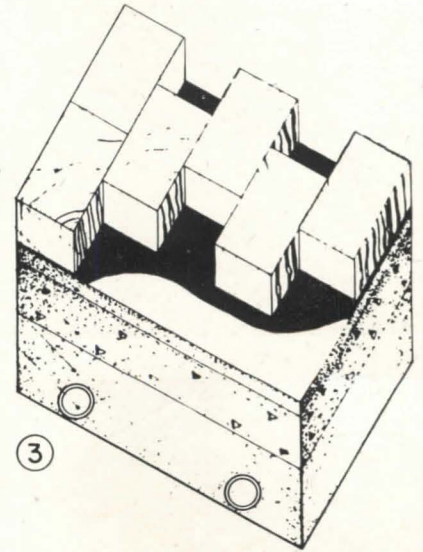

3



# ROOF CONSTRUCTION ANALYSIS

TYPE		ECONOMIC						INSTALLATION				FUNCTIONAL				
		COST		HEAT CONDUCTIV.	MAINT	FIRE RESISTANCE	SPAN	METHODS OF ATTACHING	THICK or GAUGE	WEATHER RESISTANCE	ACOUSTIC	LOAD BEARING	GENERAL DURABILITY	REMARKS		
		MAT	LABOR												WT/SQFT	
MISCELLANEOUS	1 CORR. SHEET METAL, NO INS	.06	.14	2 1/3	.15	MODERATE	GOOD	5'-9"	CLIPS AND BOLTS	18	FAIR	POOR	FAIR	MIN. SLOPE 4-12 AVAILABLE 12 TO 28 GAUGE		
	2 CORR ASBESTOS, " "	.20	.10	4 1/2	.36	LOW	EXCEL	4'-6"	" " "	7/16	EXCEL.	"	GOOD	MIN. SLOPE 3-12 " 4.2' & 2 5/8" PITCH		
	3 CORR ASBESTOS	.41	.12	9 1/2	.11	LOW	"	4'-6"	" " "	7/16	GOOD	"	"	USED AS ROOF DECK, BUTT JOINTS		
	4 WOOD DECK	.35	.27	13.0	.16	MODERATE	POOR	8'-0"	NAILS AND CLIPS	2"	GOOD	FAIR	"	"		
	5 STRUCTURAL INSULATION	.20	.10	11.3	.15	LOW	FAIR	4'-0"	CLIPS AND BOLTS	2"	GOOD	"	FAIR	MAY BE THERMAX OR CEMESTO		
	6 ROBERTSON GALBESTOS	.28	.11	3.5	.14	LOW	GOOD	6'-6"	BARS AND STRAPS	18	GOOD	"	"	COLORS, BLACK, MAROON, ALUMINUM 4 SHAPES		
PRE-CAST CONCR.	7 GYPSUM T&G PLANK	.19	.10	15	.53	NONE	4 HR	7'	CLIPS	2 1/2"	FAIR	NONE	75 LB	GOOD	UNITS: 2' x 15' x 6'	
	8 GYPSUM SHORT SPAN	.17	.23	17	.49	"	"	2'-6"	MORTAR & TEE'S	3"	"	"	"	"	3' x 12' x 30'	
	9 GYPSUM STEEL PLANK	.21	.10	12	.53	"	"	7'	TONGUE & GROOVE	2"	"	"	"	"	2' x 15' x 10'	
	10 CONCRETE PLANK	.26	.08	18	.23	"	"	8'	MORTAR JOINTS	2 3/4"	EXCEL	FAIR	60 LB	EXCEL	2 3/4' x 16' x 8'	
	11 CONCRETE TILE	.24	.07	14	.23	"	"	6'	"	"	"	"	"	"	2 3/4' x 24' x 6'-4'	
	12 FLEXCORE CONG PLANK	.28	.08	40	.20	"	"	22'	"	6"	"	"	"	"	6' x 12' x 6' TO 22'	
POURED GYFOR CONCR.	13 SHEETROCK PYROFILL	.23	.12	15	.17	LOW	EXCEL	13'-8"	SUB-PURLINS	3"	GOOD	GOOD	45 LB/SF	GOOD	SETS QUICKLY LIGHT REFLECTING	
	14 ROB Q-FK AND CONC	.48	.18	35	.24	NONE	2 HR	19'-0"	POURED ONTO PANEL	4"	EXCEL	POOR	72 "	EXCEL.	"	
	15 SUSPENDED GYFOR LWTCON	.22	.09	16	.15	LOW	4 HR	10'-0"	TEMPORARY FORMS	4"	GOOD	FAIR	40 "	GOOD	EXCELLENT F.P.R. BUT LOW STRUCT. VALUE	
	16 CONCRETE ON MTL LATH	.21	.10	26	.21	NONE	GOOD	30'	POURED ONTO LATH	2"	GOOD	"	"	GOOD	ALL MATERIALS REQUIRING FORMS ADD 70 PER SQ.FT.	
	17 CONC.SLAB, 2WAY REINF	.26	.11	56	.21	"	EXCEL	20'-0"	FORMS	4 1/2"	EXCEL	POOR	"	EXCEL.	FOR COST OF FORM, ERECTION AND STRIPPING.	
	18 RIB SLAB, TIN PAN CONST.	.27	.12	65	.21	"	"	28'-0"	FORMS	3"	"	"	"	"	RENTED FORMS, LABOR & SKILL SAVING ON LARGE 1 STORY PLANTS COST MUCH UNDER WOOD OR STEEL. AMNT. OF STEEL 31 COMP TO 58 FOR CONG.FR SLAB & 14 FOR STRUCT STEEL.	
19 CONCRETE SHELL	SEE REMKS			.21	"	"	40'-0"	"TROJAN HORSE" FORMS	3"	"	"	"	"	"	"	
METAL PLANKS AND PANELS	20 FENESTRA TYPE A	.40	.14	59	.24	NONE	2 HR	15'-0"	CLIP OR WELD TO PURLINS	18	GOOD	POOR	"	20 YRS.	ALL STEEL DECK LEND THEMSELVES TO FAST	
	21 HOLORIB SANACOUSTIC	.38	.13	32	.24	NONE	"	6'-6"	"	18	"	EXCEL.	"	"	ERRECTION A CLEAN ARCHITECTURAL APPEAR-	
	22 ROBERTSON DECK #12	.32	.10	37	.23	NONE	"	15'-0"	"	20	"	POOR	"	"	ENCE IS ACHIEVED WHERE RIBS OR FLAT SUR-	
	23 " FK DECK	.42	.14	67	.24	NONE	"	20'-0"	"	18	"	"	"	"	FACES ARE LEFT EXPOSED. RIBS BECOME AVAIL-	
	24 U.S. GYPSUM STEEL DECK	.30	.09	32	.24	NONE	"	8'-0"	"	18	"	"	"	"	ABLE TO RECEIVE ELECTRICAL CONDUITS AND	
	25 METRO "	.30	.11	29	.23	NONE	"	7'-6"	"	22	"	"	"	"	OTHER UTILITIES MOST TYPES COME IN MULTI-	
	26 MILCOR "	.31	.12	31	.24	NONE	"	7'-6"	"	18	"	"	"	"	PLES OF 6" STARTING AT 4'-0" CARE SHOLD BE	
	27 CECO "	.31	.12	31	.24	NONE	"	7'-6"	"	18	"	"	"	"	TAKEN IN CASES WHERE PROTECTIVE PAINT OR	
	28 TRUSCON "	.30	.10	25	.23	NONE	"	8'-0"	"	20	"	"	"	"	ASHPHALT IS USED IN PREFABRICATION-CORROS-	
	29 MAHON "	.32	.12	32	.23	NONE	"	7'-6"	"	20	"	"	"	"	ION WILL START ON UNPROTECTED SURFACES...	
	30 WHEELING LONG SPAN	.35	.13	40	.24	NONE	"	14'-0"	"	16	"	"	"	"	"	

FOR THIS ANALYSIS ALL DECKS WERE FIGURED AT 40 SQFT ROOF LD. THIS GIVES A SPAN VARIABLE.

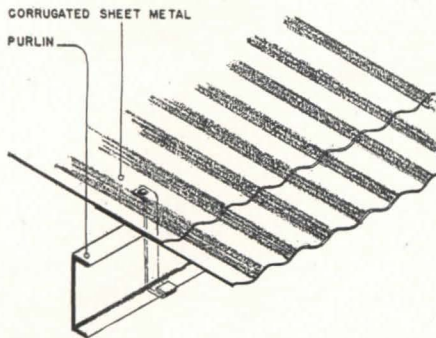

1

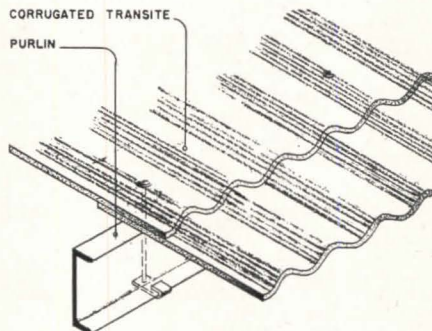

2

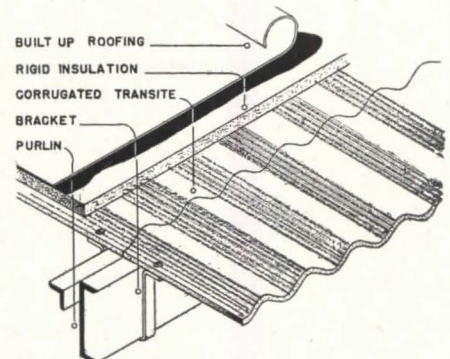

3

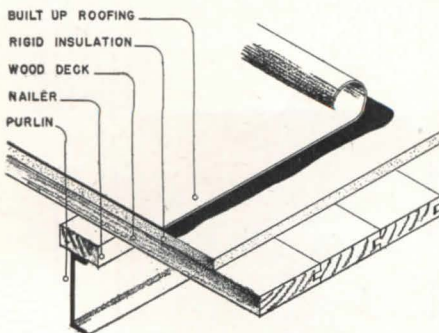

4

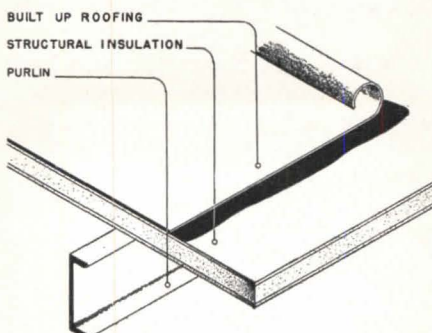

5

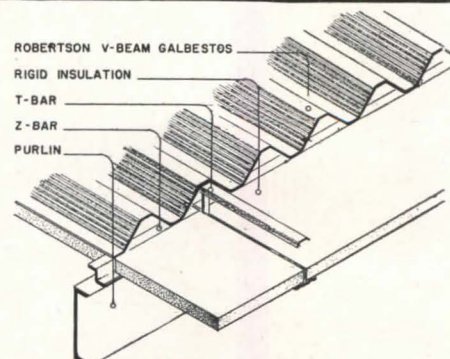

6



GYPSUM TONGUE & GROOVE PLANK  
2' x 15' x 6'-0"

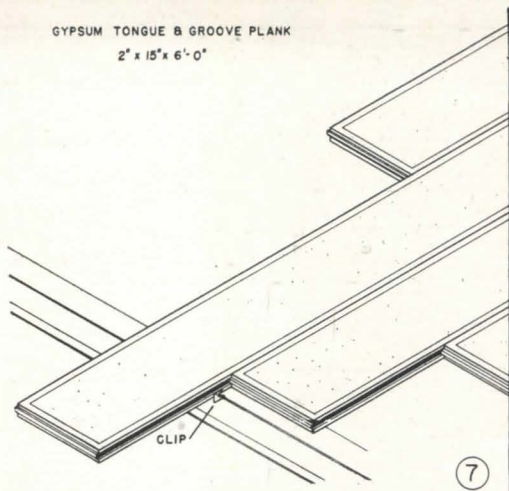

7

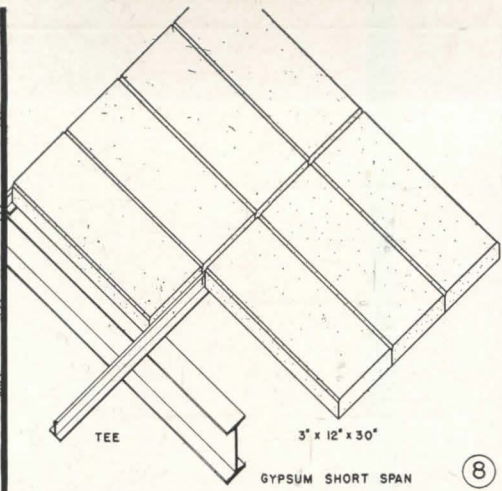

8

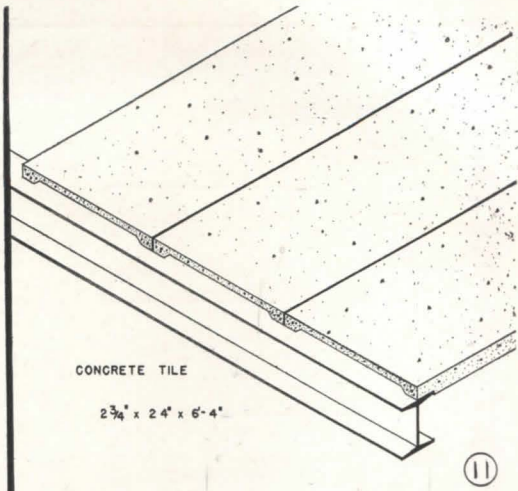

11

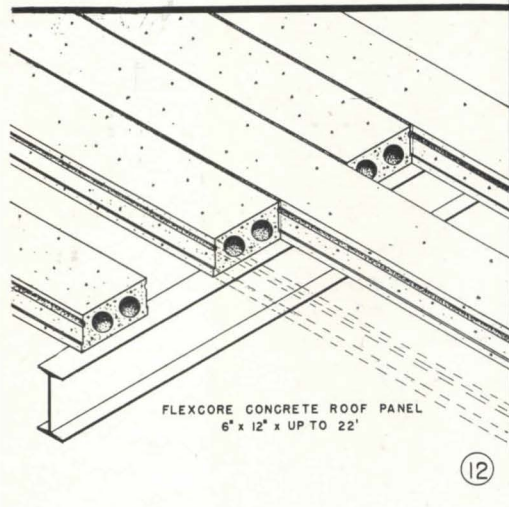

12

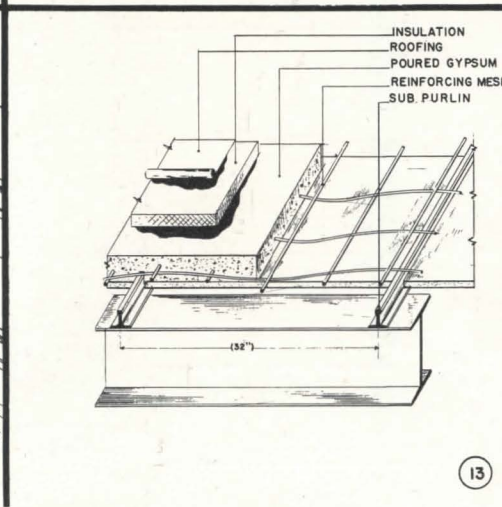

13

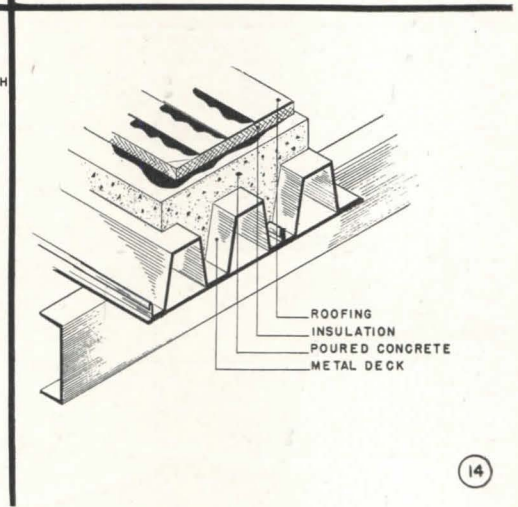

14

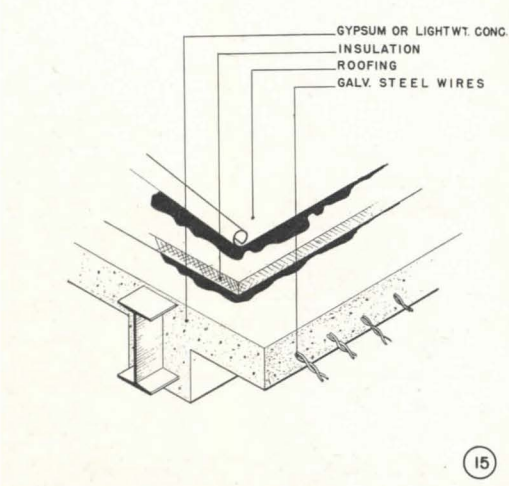

15

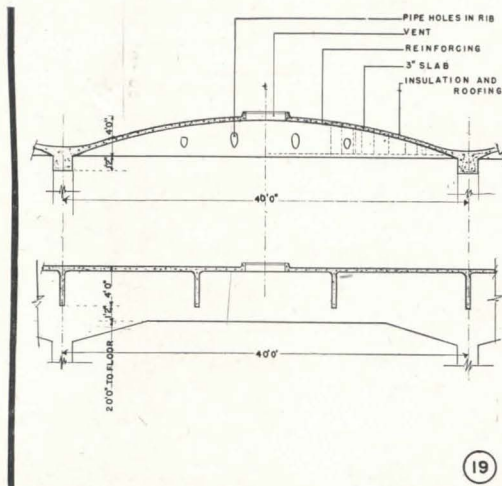

19

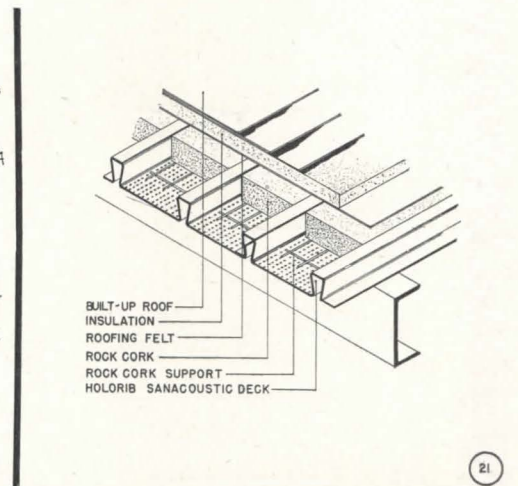

21



22

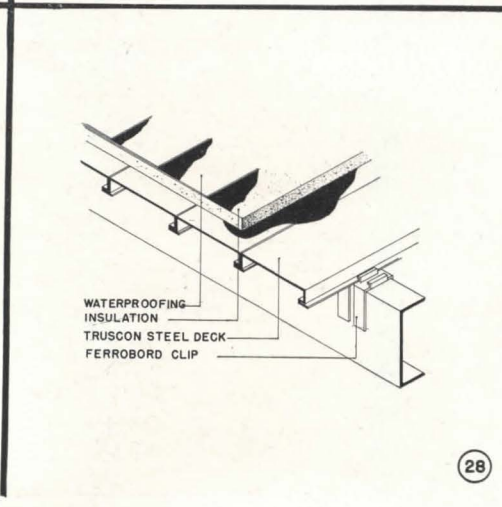

28



30



# FRAMING ANALYSIS

20 x 20

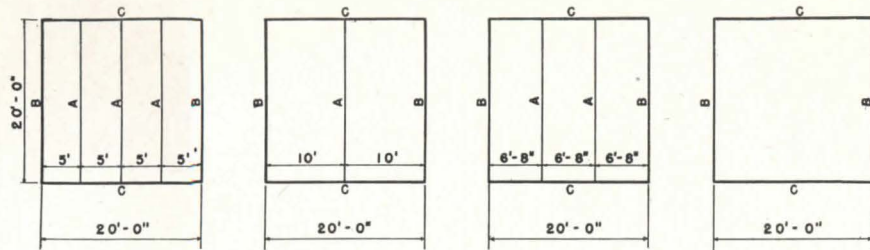

ROOFING	PURLIN SPACING IN FEET	WT. OF MEMBERS PER BAY			WT. OF COLUMN PER BAY	WT. OF STEEL PER SQ. FT.
		A	B	C		
STEEL	5'	10 JR 9 540	14 WF 30 600	14 WF 30 600	680	6.05
D.O.	10'	12 B 14 280	14 WF 30 600	14 WF 34 680	680	5.6
D.O.	20'	0	16 WF 36 720	12 WF 27 540	680	4.85
GYPSUM	6'-8"	12 JR 11.8 472	14 WF 34 680	14 WF 34 680	680	6.27
CONCRETE	20'	0	16 WF 40 800	12 WF 27 540	680	5.05

20 x 30

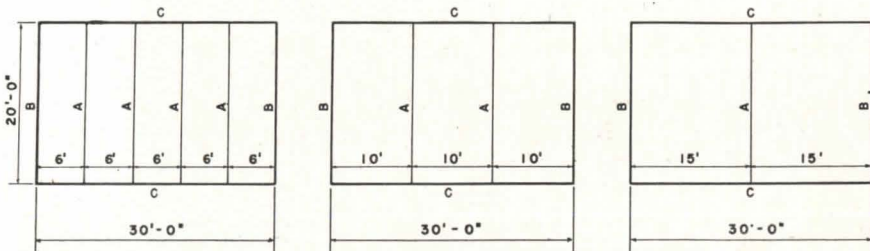

ROOFING	PURLIN SPACING IN FEET	WT. OF MEMBERS PER BAY			WT. OF COLUMN PER BAY	WT. OF STEEL PER SQ. FT.
		A	B	C		
STEEL	6'	10 JR 9 720	14 WF 30 600	18 WF 55 1650	680	6.08
D.O.	10'	12 B 14 840	14 WF 30 600	18 WF 64 1920	680	6.73
D.O.	15'	12 B 19 380	14 WF 30 600	21 WF 68 2040	680	6.16
CONCRETE	15'	14 WF 30 600	16 WF 36 720	27 WF 102 3080	680	8.43

30 x 30 Bay

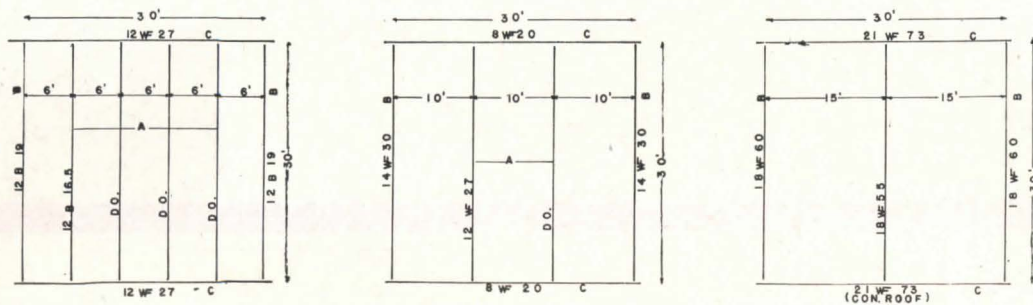

ROOFING	PURLIN SPACING	WT. OF MEMBERS / BAY			lb. of Col. per. BAY	lb. of Steel / Ft. of Floor
		A	B	C		
STEEL	6'	1140	1625	1920	698	6.1
D.O.	10'	1800	1200	1625	698	5.9
CON.	15'	3600	4400	1625	698	11.5
GYPSUM	6'	1625	1625	2640	698	7.3

Plant area = 112 BAYS @ 900 sq. ft. ea. = 100 800 sq. ft.  
 No. of interior columns = 91  
 No. of columns per. bay = 12  
 Total area lost to columns @ 12 sq. ft. per. column = 1 650 sq. ft.



## 40 x 40 Bay

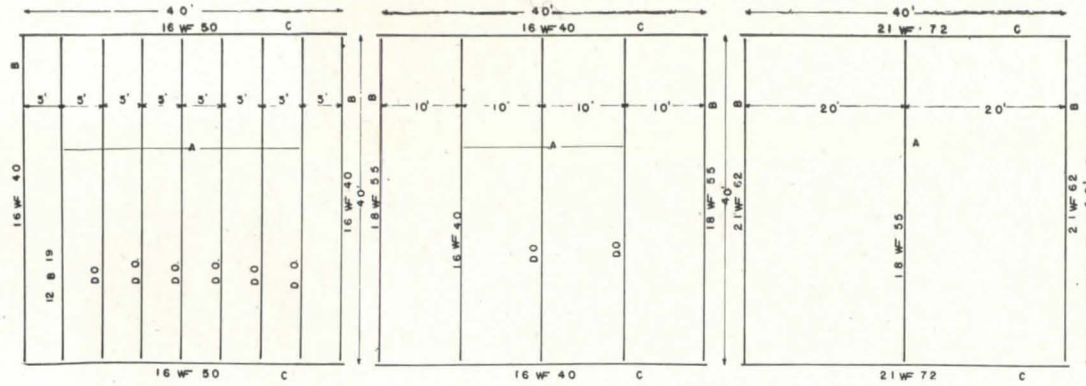

ROOFING	PURLIN SPACING	WT. OF MEMBERS / BAY			lb. of Col. / BAY	lb. of Steel / Ft. of Floor
		A	B	C		
STEEL	5'	5 320	3 200	4 000	610	8.2
DO	10'	2 280	4 400	3 200	610	6.5
DO	20'	760	4 960	5 760	610	7.55
CON.	20'	3 760	8 160	8 160	610	12.9
GYPSM	5'	3 200	3 600	3 600	610	6.79

Plant area = 66 BAYS @ 1600 sq. ft. ea. = 105,600 sq. ft.  
 No. interior columns = 50  
 No. of columns per bay = 1.27  
 Total area lost to columns @ 12 sq. ft. per column = 760 sq. ft.

## 20' x 40'

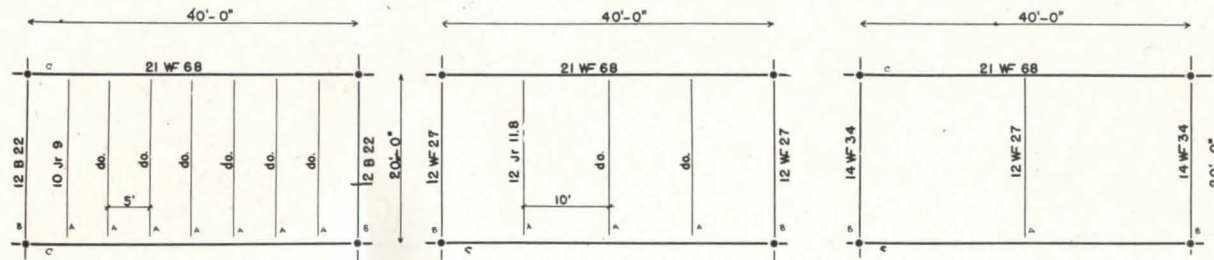

ROOFING	PURLIN space in feet	WT. of MEMBERS / BAY			lbs. of COL. / BAY	WT. of steel per sqft
		A	B	C		
STEEL PLANK	5'	1260	440	2720	680	6.9
	10'	707	540	2720	680	6.3
	20'	540	680	2720	680	6.27
CONCRETE	20'	720	900	408	680	8.7
GYPSUM PLANK	5'	1260	540	2920	680	7.34

PLANT AREA: 26 Bay @ 800 sq. ft. = 100,800 sq. ft.  
 No. of interior Columns = 100  
 No. of columns per bay = 1.22  
 total area LOST to column @ 12 sq. ft. per col. .... 1200 sq. ft.

## 30' x 40'

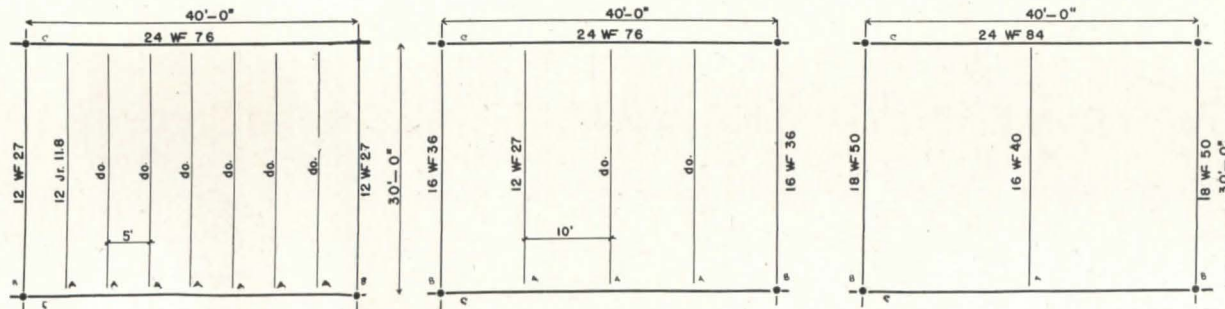

ROOFING	PURLIN space in feet	WT. of MEMBERS / BAY			lbs. of COL. / BAY	WT. of steel per sqft
		A	B	C		
STEEL PLANK	5'	2940	810	3040	697	6.8
	10'	2430	1080	3040	697	6.58
	20'	1200	1500	3360	697	6.15
CONCRETE	20'	1860	2190	5960	789	9.85
GYPSUM PLANK	5'	3950	1080	3360	697	8.27

PLANT AREA: 84 Bay @ 1200 sq. ft. = 100,800 sq. ft.  
 No. of interior Columns = 65  
 No. of columns per bay = 1.25  
 total area LOST to column @ 12 sq. ft. per col. .... 780 sq. ft.



# FRAMING ANALYSIS

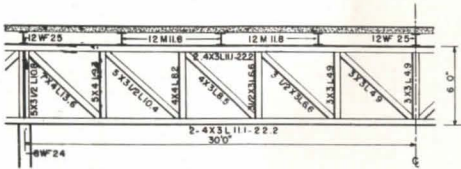
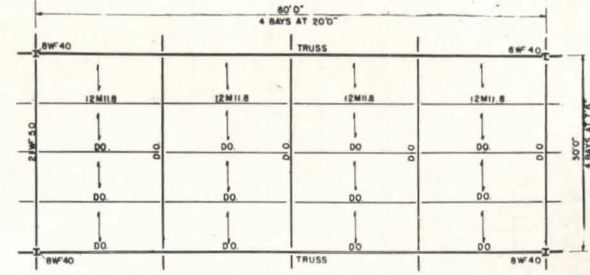
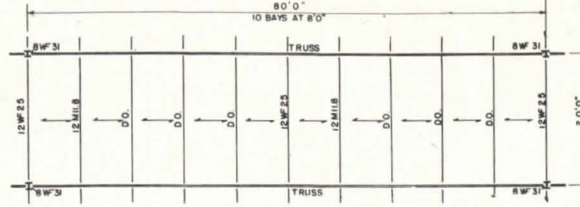
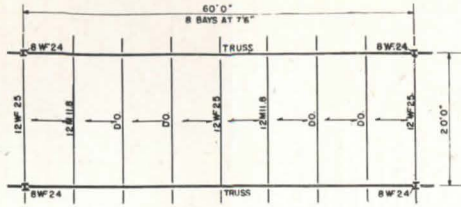

20'0" X 60'0" BAY

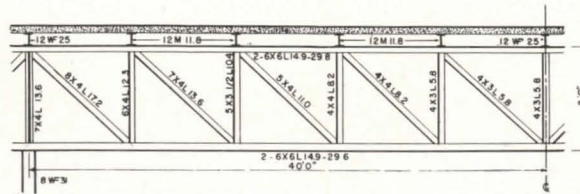

20'0" X 80'0" BAY

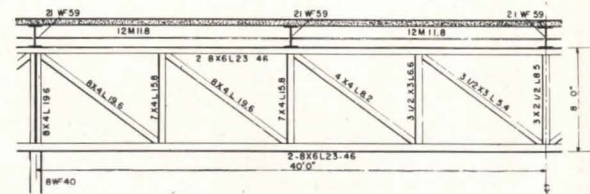

30'0" X 80'0" BAY

## TRUSS FRAMING

ADVANTAGES	DISADVANTAGES
FEWER COLUMNS	MORE STEEL REQUIRED
SMALLER FLOOR AND ROOF AREAS	GREATER OVERALL BUILDING VOLUME
MORE EFFICIENT MACHINE LAYOUT	MORE WALL AND PARTITION AREA
LIGHTS, PIPES, ETC. LOCATED IN TRUSS WHERE OUT OF WAY BUT EASILY SERVICED BY CATWALKS	GREATER FABRICATION COST
FEWER COLUMN FOOTINGS	MORE STRUCTURAL MEMBERS TO MAINTAIN
READILY ADAPATABLE TO MONITOR TYPE NATURAL LIGHTING	

BAY SIZE	20'0" X 60'0"	20'0" X 80'0"	30'0" X 80'0"
LIVE LOAD AND ROOFING	50 LBS/SQ.FT.	50 LBS/SQ.FT.	50 LBS/SQ.FT.
PURLIN SPACING	7'6"	8'0"	7'6"
SIZE OF PLANT	100,000 SQ.FT.	100,000 SQ.FT.	100,000 SQ.FT.
NUMBER OF INTERIOR COLUMNS	60	40	26
AREA LOST TO COLUMNS AT 12 SQ.FT./COL	720 SQ.FT.	480 SQ.FT.	312 SQ.FT.
WT STEEL /SQ. FT. FLOOR AREA	6.9 LBS/SQ.FT.	8.75 LBS/SQ.FT.	10.3 LBS/FTSQ.

# TRUSSES



# MECHANICAL PLANT

## No. 1. FOR THE LUXURY PLANT

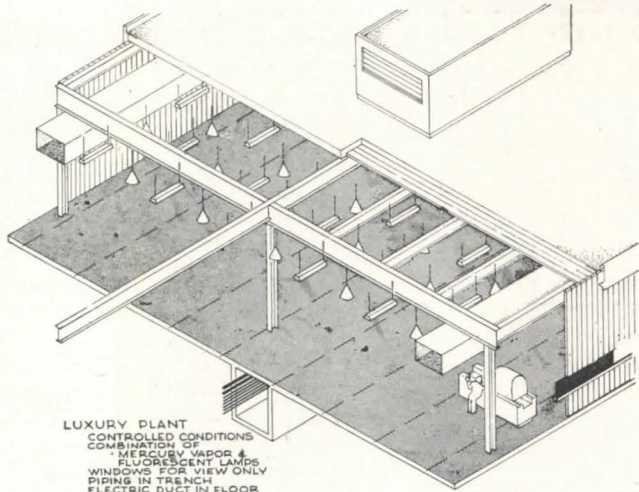

**LUXURY PLANT**  
 CONTROLLED CONDITIONS  
 COMBINATION OF  
 MERCURY VAPOR &  
 FLUORESCENT LAMPS  
 WINDOWS FOR VIEW ONLY  
 PIPING IN TRENCH  
 ELECTRIC DUCT IN FLOOR  
 ROOF WATER-SPRAYED  
 ROOF HOUSING FOR  
 AIR-CONDITIONING

**ADVANTAGES:**  
 INCREASED WORKER  
 COMFORT & EFFICIENCY  
 CLEAR CEILING  
 ELECTRIC AVAILABILITY  
 CONTROL FOR PRECISION WORK

**DISADVANTAGES:**  
 HIGHER INITIAL &  
 OPERATING COSTS

CONSTRUCTION COSTS

ANNUAL OPERATING COST  
& FIXED CHARGES

OPERATING COSTS  
2 - 8 HOUR SHIFTS

COSTS OF CONVENTIONAL PLANTS  
& CONTROLLED CONDITIONS PLANTS

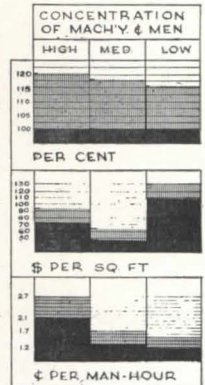

## No. 2. FOR THE AVERAGE PLANT

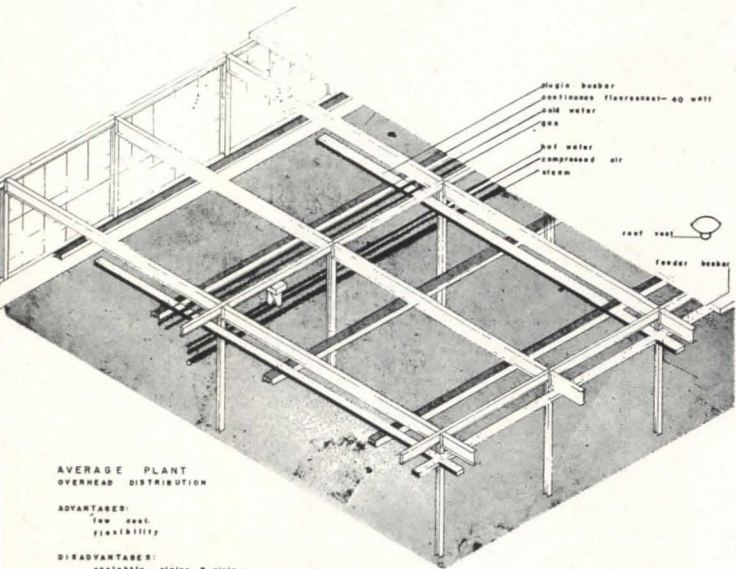

**AVERAGE PLANT**  
 OVERHEAD DISTRIBUTION

**ADVANTAGES:**  
 Low cost  
 flexibility

**DISADVANTAGES:**  
 unsightly piping & wiring  
 Minimum protection for  
 temperature control

hugin boiler  
 continuous floorcoat-40 wet  
 hot water  
 steam  
 hot water  
 compressed air  
 steam

roof vent  
 fender boiler

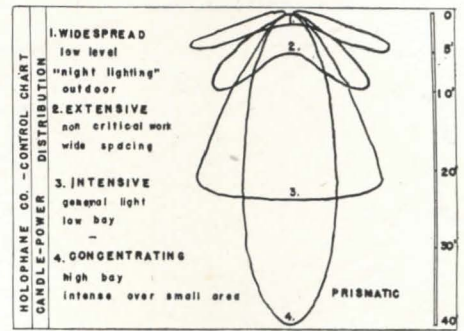

ILLUMINATION

## No. 3. FOR THE MINIMUM PLANT

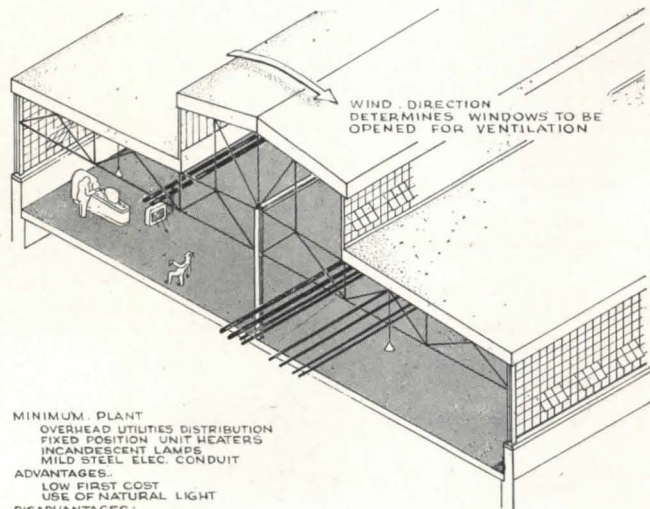

**MINIMUM PLANT**  
 OVERHEAD UTILITIES DISTRIBUTION  
 FIXED POSITION UNIT HEATERS  
 INCANDESCENT LAMPS  
 MILD STEEL ELEC. CONDUIT

**ADVANTAGES:**  
 LOW FIRST COST  
 USE OF NATURAL LIGHT

**DISADVANTAGES:**  
 RELIANCE ON WEATHER FOR  
 PROPER LIGHTING &  
 VENTILATING  
 MANUAL CONTROL OF VENTI-  
 LATING  
 ELECTRICAL "INAVAILABILITY"  
 CLUTTERED TRUSSES

WIND DIRECTION  
 DETERMINES WINDOWS TO BE  
 OPENED FOR VENTILATION

EFFECT OF SPAN ON DAYLIGHTING DISTRIBUTION, USING SLOPING WINDOWS

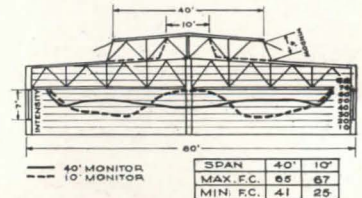

**GENERAL:**  
 1. MAXIMUM USE MADE OF NATURAL LIGHTING.  
 2. INCANDESCENT LAMPS USED TO AUGMENT DAYLIGHT & SPOT PARTICULAR AREAS.

ILLUMINATION



# THREE "COMMENDED" PROJECTS IN PLANT DESIGN

By Walter F. Bogner

Professor of Architecture, Harvard University

In this study the students were required to design a plant with two types of manufacturing space: one for manufacturing, storage, and assembly, 100,000 sq. ft. in area, in which no machine was over 14 ft. in height; the other for drop forging and heat treating, 30,000 sq. ft. of floor space, in which great height was demanded for forge hammers and an overhead crane. In the latter, noise and extreme heat from furnaces produced special problems. Offices, a display room, and such general plant requirements as boiler house, cafeteria and recreation facilities, personnel office, clinic, gate house, plant repair and maintenance shop, garage and truck service shop, were also required.

The students were given as objec-

tives the following five requirements:

1. *A minimum of materials handling.* Good production flow, short lines of transportation, no back-tracking in aisles, strategic location of the areas allocated to raw material storage, processing, finished parts storage, assembly, finished goods storage, and shipping were demanded.

2. *Maximum flexibility.* The easy rearrangement of machine layout for anticipated changes in the products or in the production methods was considered essential.

3. *Operation with a minimum of overhead personnel.* A combining of production areas and storage areas for supervision and control by a minimum number of employees was deemed advisable.

4. *Balanced expansion possibilities.* Provisions for the growth of each component part of the plant had to be provided in proper size.

5. *Minimum cost of rearrangement in connection with internal changes and external enlargement of the plant.* Hereunder provisions had to be made which permitted the moving of walls, windows, and partitions to new locations with a minimum of expense.

The students were organized in teams of two for the development of the industrial plant designs. Commendations of the jury were given to the three projects which were submitted by Stephenson and Underwood; Turano and Page; Sink and Rosé. All were students in architecture.

## No. 1. BY STUDENTS SINK AND ROSÉ

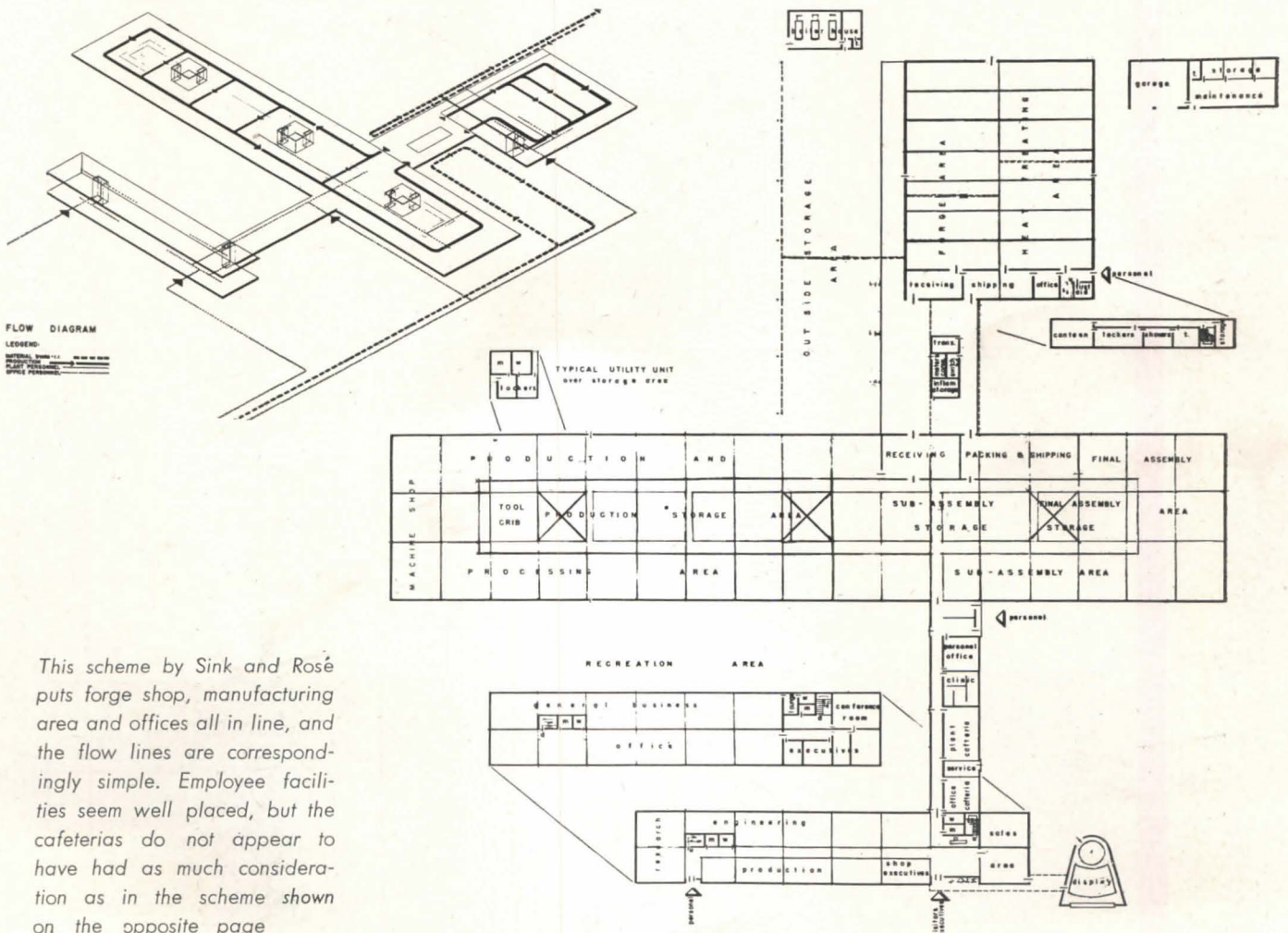

This scheme by Sink and Rosé puts forge shop, manufacturing area and offices all in line, and the flow lines are correspondingly simple. Employee facilities seem well placed, but the cafeterias do not appear to have had as much consideration as in the scheme shown on the opposite page



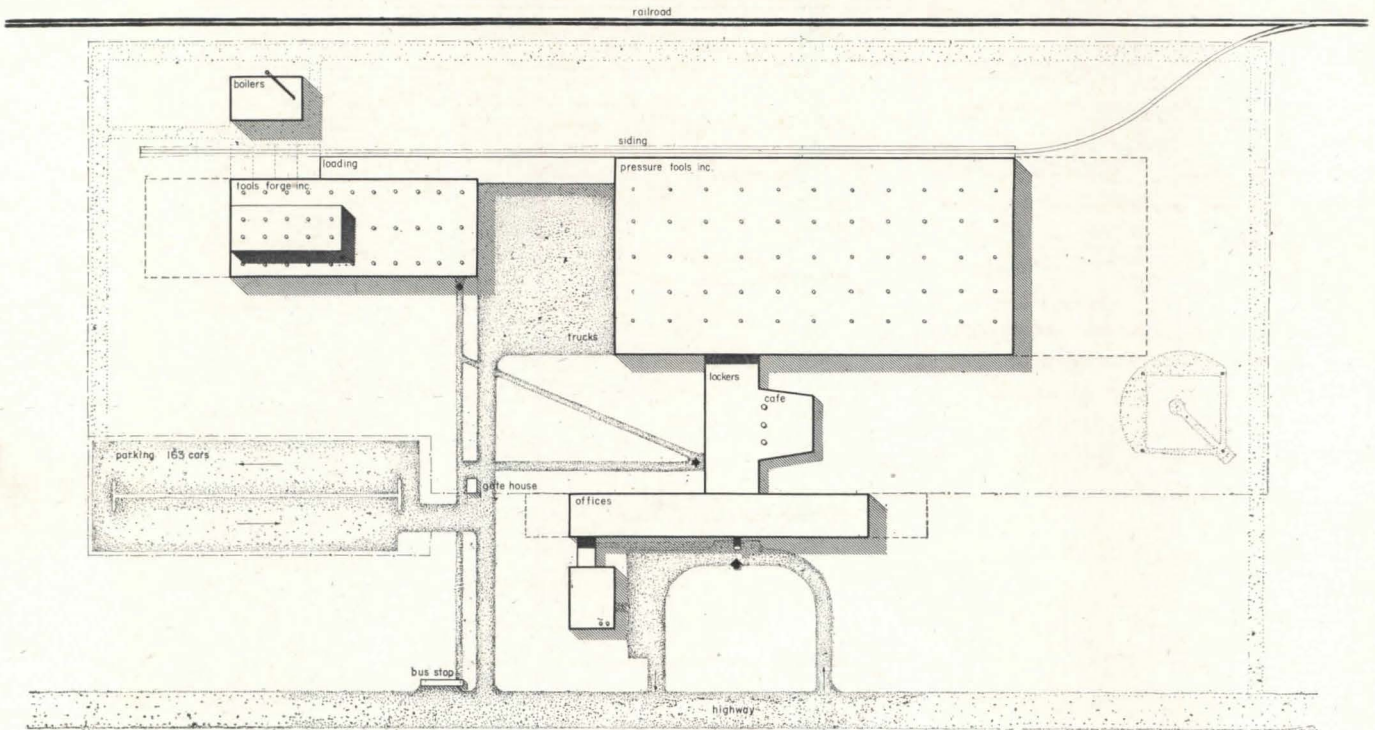

Assuming a railroad spur running along the rear of the site, Students Stephenson and Underwood put the forge shop at the side of the main manufacturing building. This would seem to provide excellent loading facilities for both incoming materials

and outgoing finished products. In this design the cafeteria is given prominence, and a larger scale plan (not shown) indicates development of outdoor lounge areas on both sides of the cafeteria, a feature which no doubt would be much appreciated

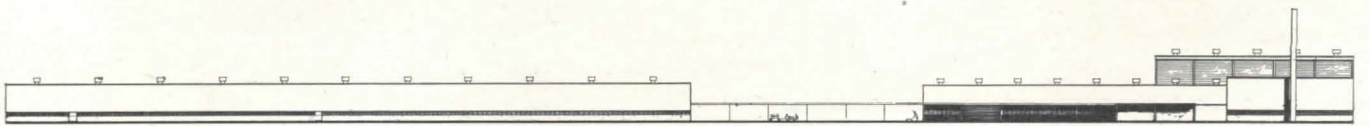
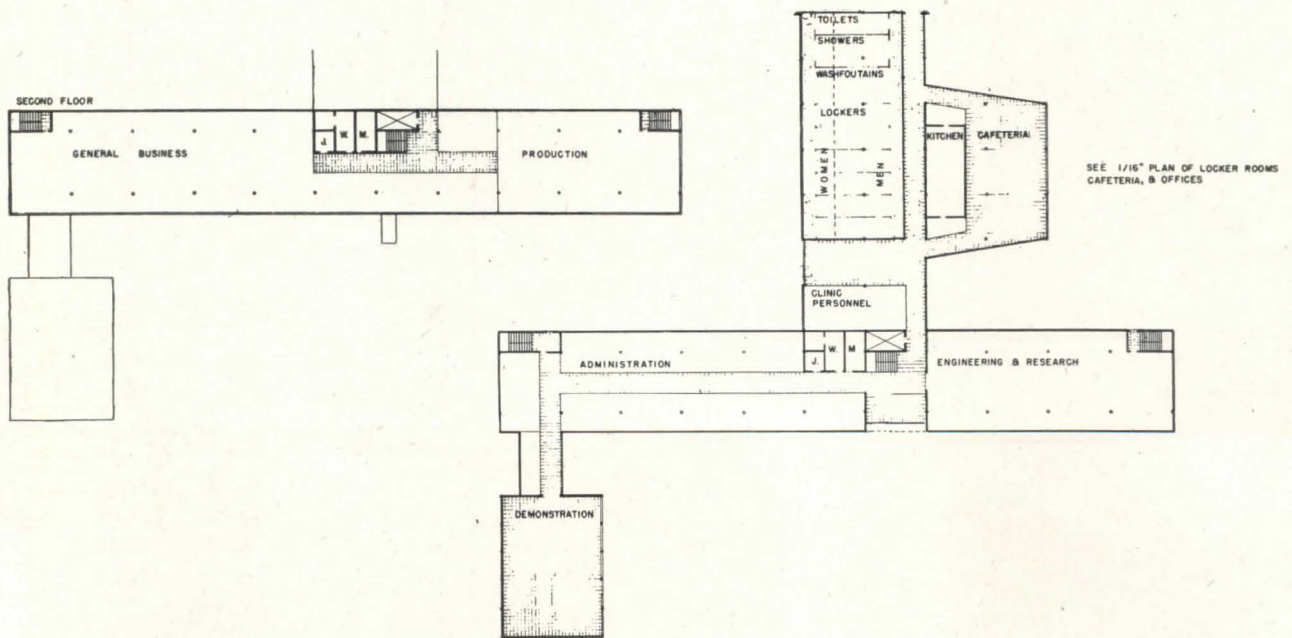



**No. 3. BY STUDENTS TURANO AND PAGE**

This scheme develops the in-line arrangement of forge shop, manufacturing area and office portion. Here, however, the office section is split into parts and arranged to enclose a courtyard complete with spray pool and the columned arcade frequently seen in Continental architecture. The divisions appear completely logical, and who is to say that manufacturing plant cannot just as well stand some freedom in design as some of the other building types in which such devices are more commonly seen?

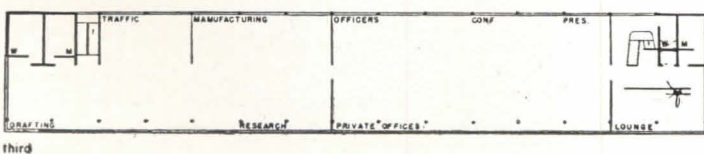
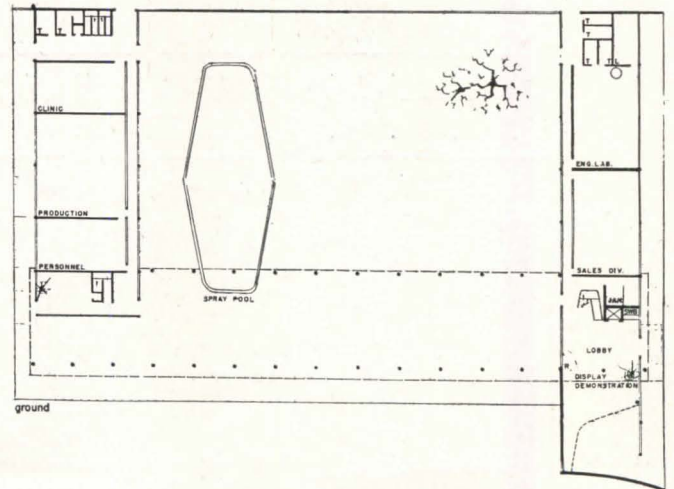
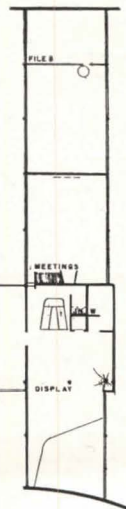
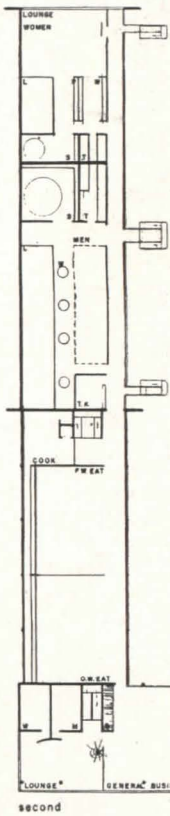
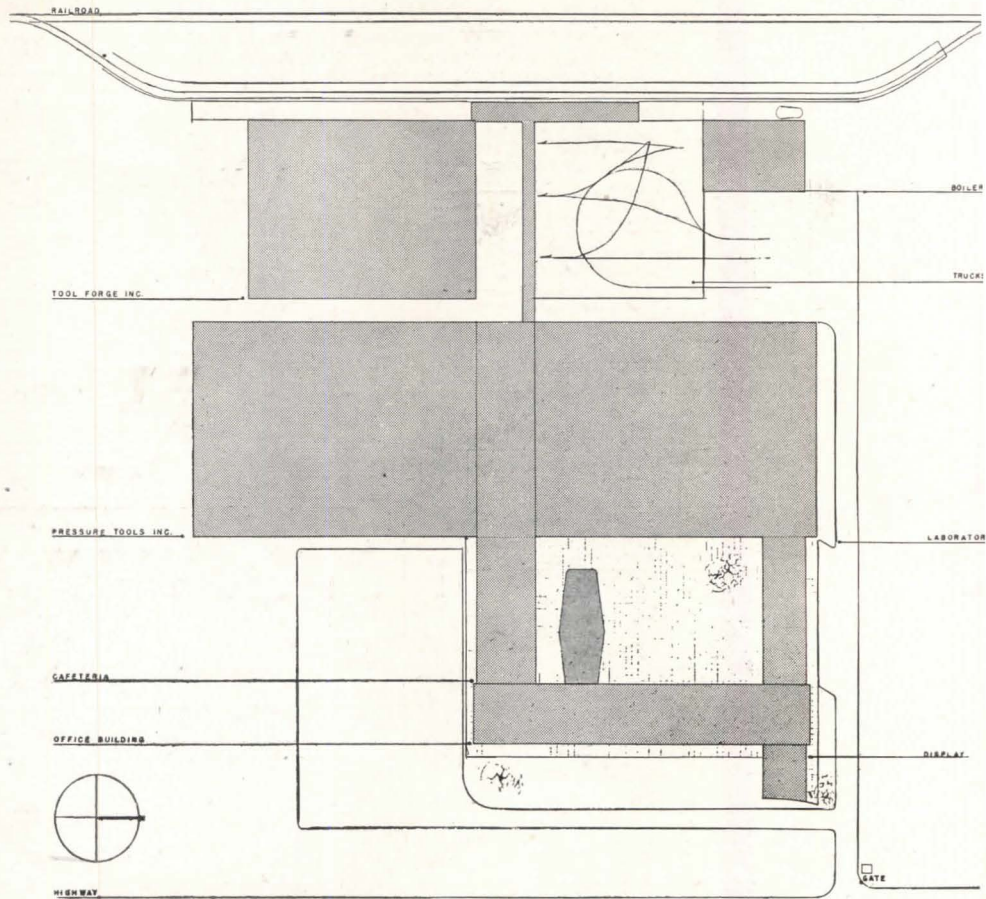



AUGUST 1947

ARCHITECTURAL RECORD

## ECONOMICAL STEEL FRAMING DETAILS

Suggestions of American Institute of Steel Construction for Small Industrial Buildings

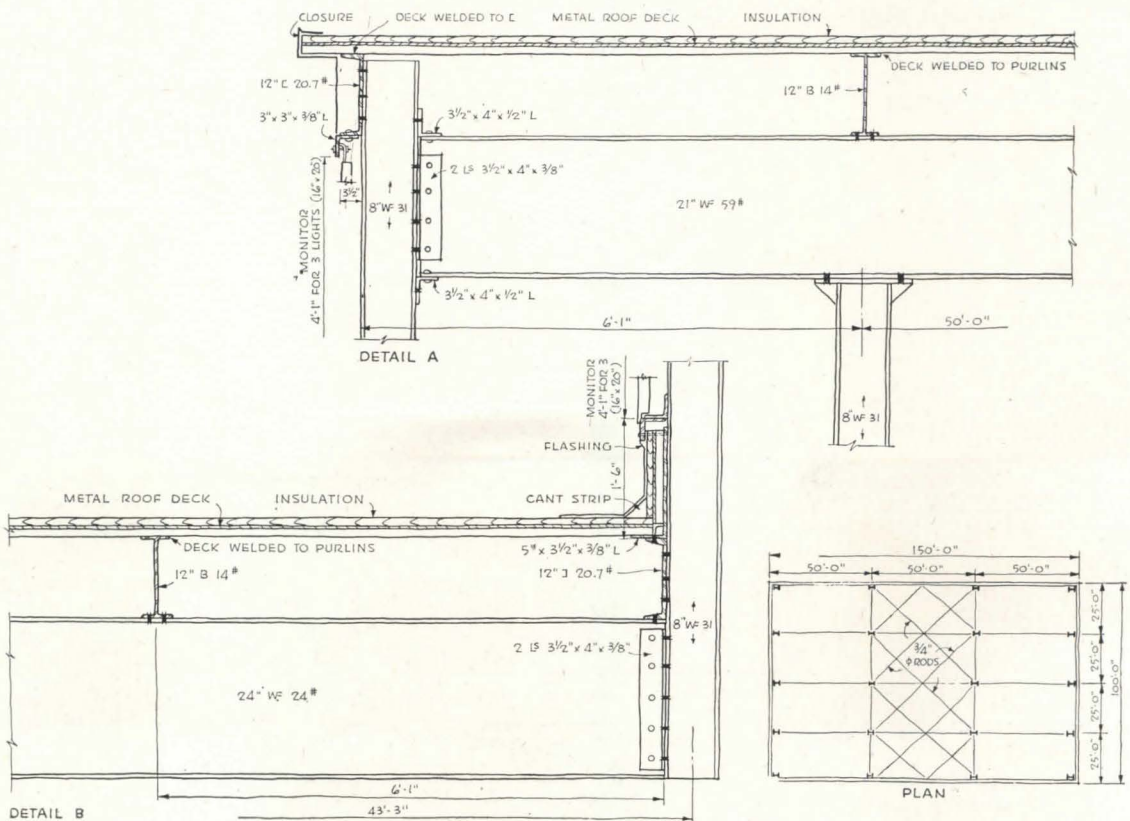
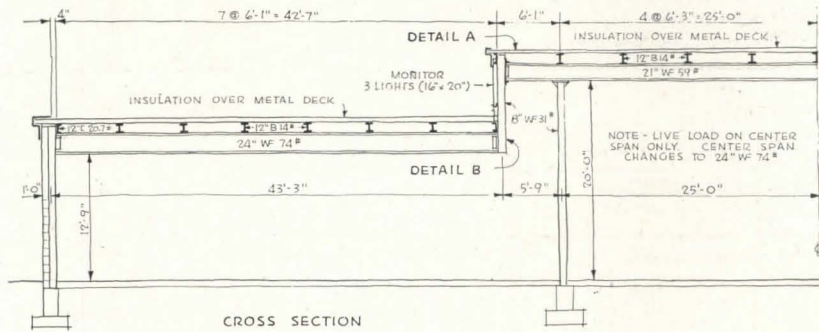
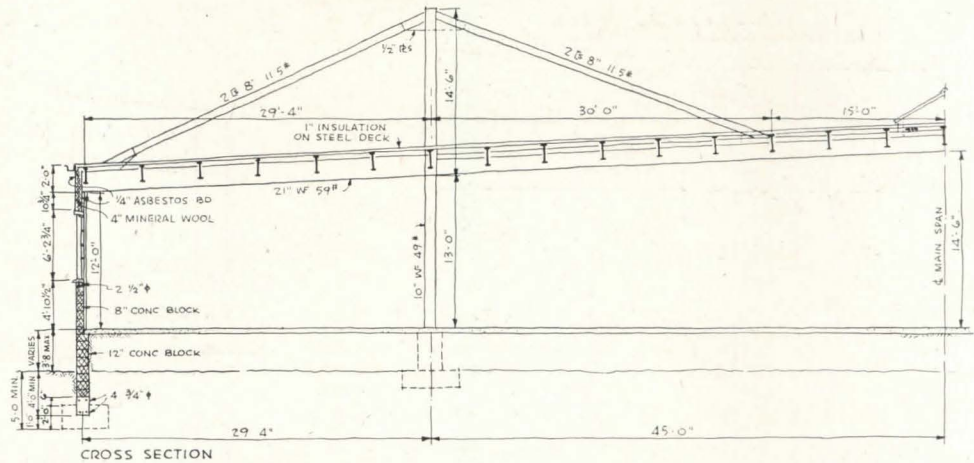



## ECONOMICAL STEEL FRAMING DETAILS (Continued from page 115; continued on page 119)

Suggestions of American Institute of Steel Construction for Small Industrial Buildings

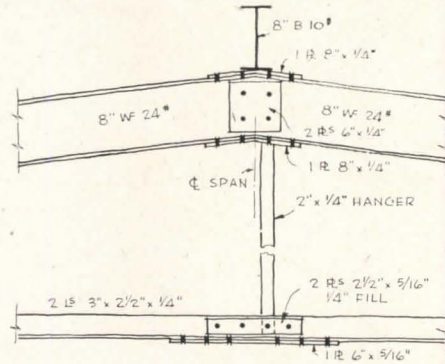
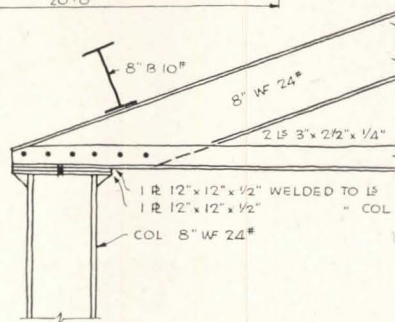
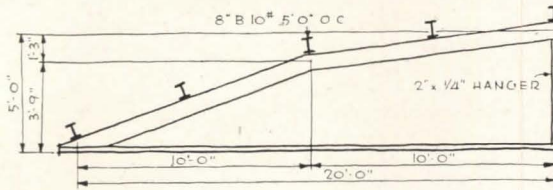

**40' TIED ARCH**  
DESIGNED FOR 50# PER SQ. FT.  
(30# LL - 20# DL) AT 20' CENTERS

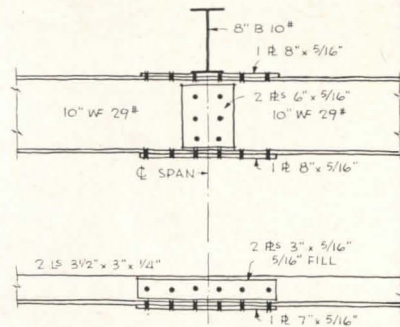
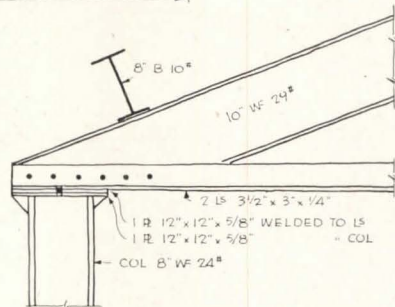
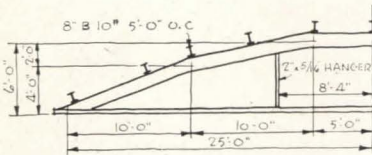

**50' TIED ARCH**  
DESIGNED FOR 50# PER SQ. FT.  
(30# LL - 20# D.L.) AT 20' CENTERS

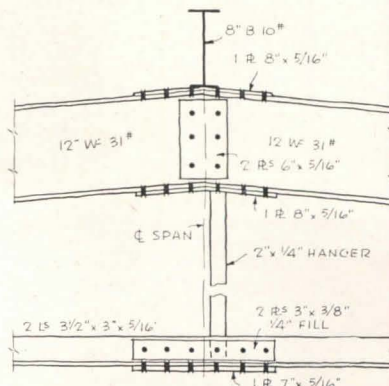
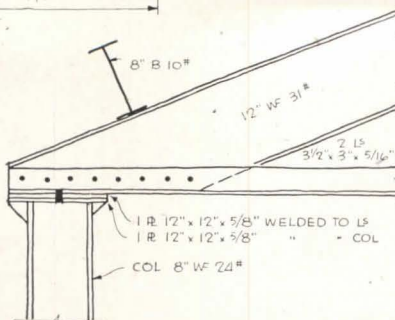
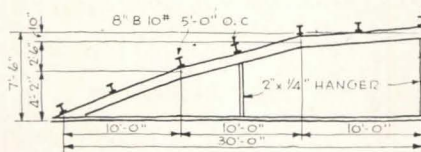

**60' TIED ARCH**  
DESIGNED FOR 50# PER SQ. FT.  
(30# LL - 20# DL) AT 20' CENTERS





**The specification  
that insured  
a client's good will**

The specification affected only slightly the total cost of the structure. Yet it had a tremendous effect on the client's satisfaction. For where freedom from distracting, nerve-straining noises is important to human comfort and efficiency, no interior can be fully acceptable without suitable sound conditioning.

Yes, even when costs must be cut to the bone, specifying sound conditioning is good counsel—and effective insurance of your client's good will.

When planning a building in which an atmosphere of quiet comfort is wanted, remember this—more sound conditioning has been done with Acousti-Celotex\* than with any other material. That is significant evidence of Acousti-Celotex superiority.

The Celotex Corporation line of acoustical materials is complete and up-to-date, as pictured and described in your Sweet's Catalog. For the latest data on availability of any Acousti-Celotex materials in the quantities your specifications may require, consult the local Acousti-Celotex distributor. Or address your question to The Celotex Corp., Dept. AR478, Chicago 3, Ill.

*Sound Conditioning with*  
**ACOUSTI-CELOTEX**



Sold by Acousti-Celotex Distributors Everywhere  
In Canada: Dominion Sound Equipments, Ltd.

**A PRODUCT OF THE CELOTEX CORPORATION • CHICAGO 3, ILLINOIS**



# OPTICALLY ENGINEERED...

to brighten the buildings you design...

whatever their purpose...

with a flood of restful, glarefree DAY-BRITE lighting...

from functional fixtures of good taste...

that harmonize with your architectural treatment.

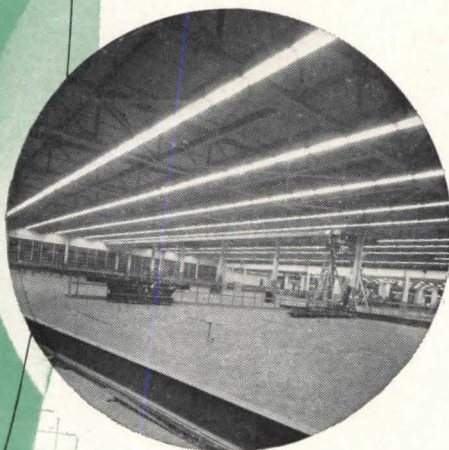

FLUORESCENT LIGHTING FIXTURES



IT'S EASY TO SEE WHEN IT'S

# DAY-BRITE

*Lighting*

DAY-BRITE LIGHTING, INC., ST. LOUIS, MO.

5465 Balwer Avenue

Nationally distributed through leading electrical supply houses.

In Canada: Amalgamated Electric Corp., Ltd., Toronto 6, Ont.

723





## ECONOMICAL STEEL FRAMING DETAILS (Continued from page 116; continued on page 121)

Suggestions of American Institute of Steel Construction for Small Industrial Buildings

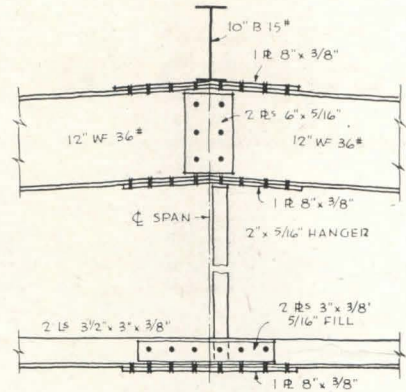
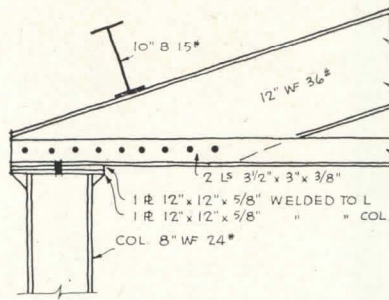
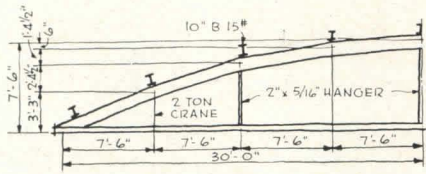

**60' TIED ARCH WITH 2 TON CRANE**  
DESIGNED FOR 50\* PER SQ. FT. (30\* LL - 20\* D.L.) & 2 TON CRANE 7'-0" FROM THE END - AT 20' CTRS.

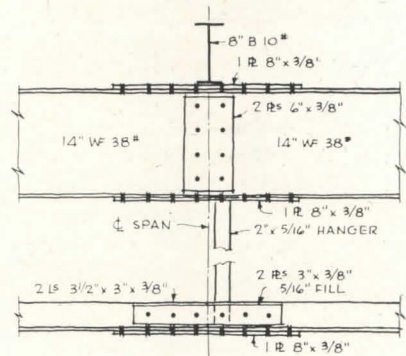
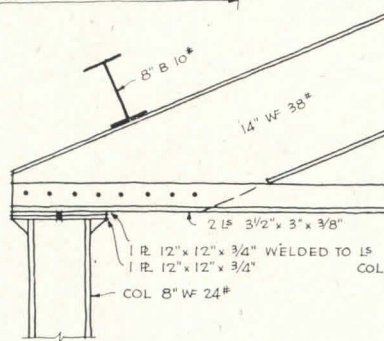
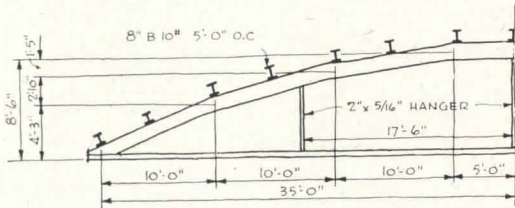

**70' TIED ARCH**  
DESIGNED FOR 50\* PER SQ. FT. (30\* LL - 20\* D.L.) AT 20' CENTERS

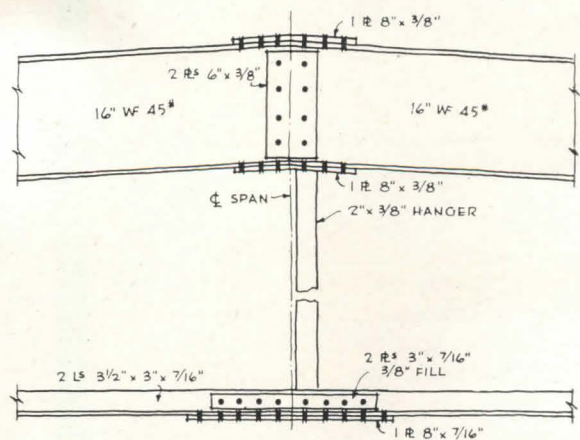
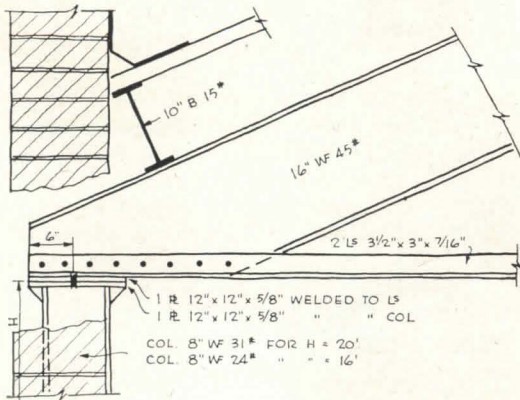
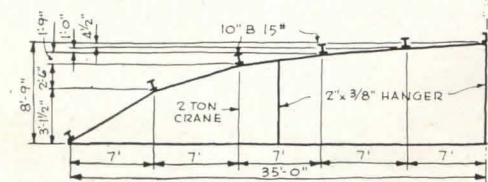

**70' TIED ARCH WITH 2 TON CRANE**  
DESIGNED FOR 50\* PER SQ. FT. 20' CENTERS AND 2 TON CRANE 14'-0" FROM END



# WHAT'S IN A NAME-plate? PLENTY..

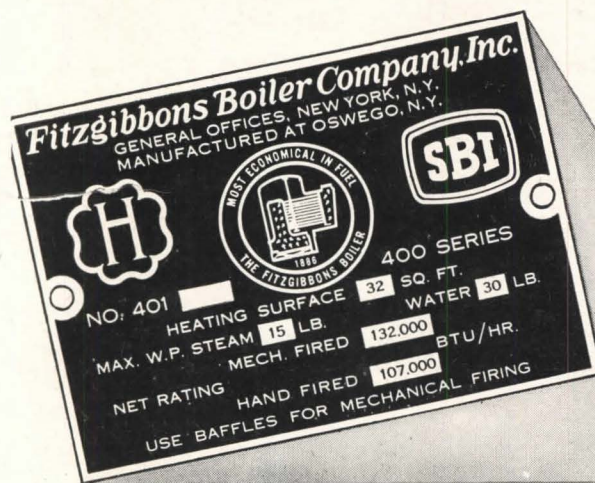

Here's a boiler name-plate that's as informative as a trip through the boiler plant. The four-leaf clover symbol with the "H" in the center is the familiar mark of the American Society of Mechanical Engineers. The Fitzgibbons steel boiler upon which it appears, in design, materials, and workmanship, exceeds the standards set by this engineering authority. That's something to know about a boiler.

Then take the "SBI" Symbol on the other corner. It means that the Boiler has been laboratory tested in accordance with the Steel Boiler Institute Code and its rating proven accurate. It eliminates wishful thinking, disappointment, and dissatisfaction in boiler performance. You know what that boiler will do.

The third symbol is the Fitzgibbons trade mark, (Reg. U. S. Pat. Off.) which for over sixty years has been regarded as a top-flight mark of steel boiler excellence.

For further confirmation, if such were needed, see the stamp of the Hartford Steam Boiler Insurance Service, on the tube extension. Their representative inspects Fitzgibbons steel boilers before shipment, and "OK's" them only after rigid examination.

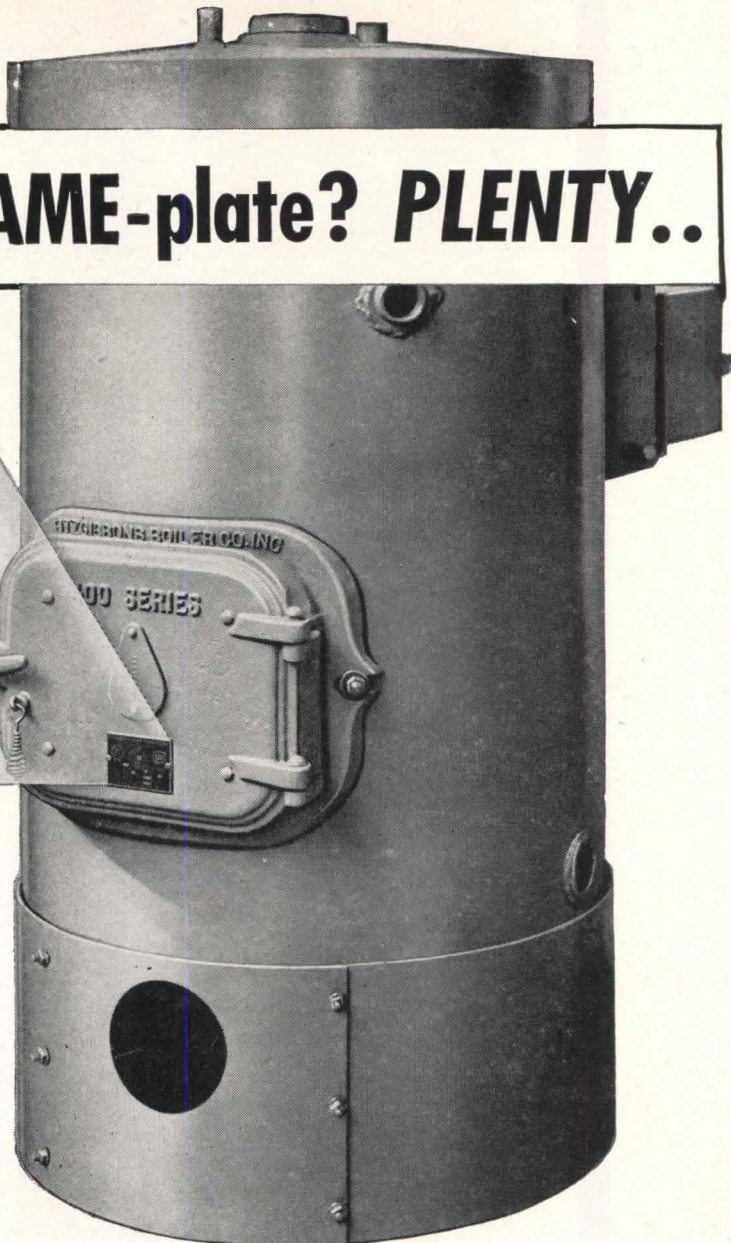

*This is the bare boiler without trim or insulation. The quickly attached jacket, now available, covers and protects everything including burner and all controls.*

## FITZGIBBONS 400 SERIES

is the steel boiler that in the small and medium size home will help any oil burner do its utmost. Quick-heating, enduring, quickly installed, easily serviced, it is ideal for replacement or new installations. From name plate to boiler plate you're betting on a sure thing when you select a Fitzgibbons steel boiler. Full data in the bulletin — write.

**Fitzgibbons Boiler Company, Inc.**

101 PARK AVENUE, NEW YORK 17, N. Y.

Manufactured at: OSWEGO, N. Y.

Sales Branches in Principal Cities



## ECONOMICAL STEEL FRAMING DETAILS (Continued from page 119)

Suggestions of American Institute of Steel Construction for Small Industrial Buildings

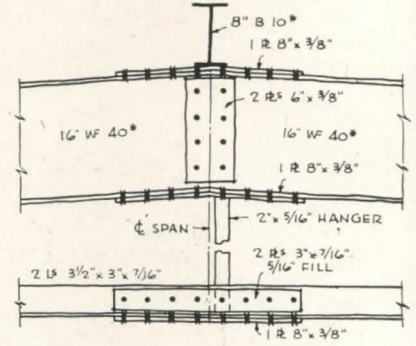
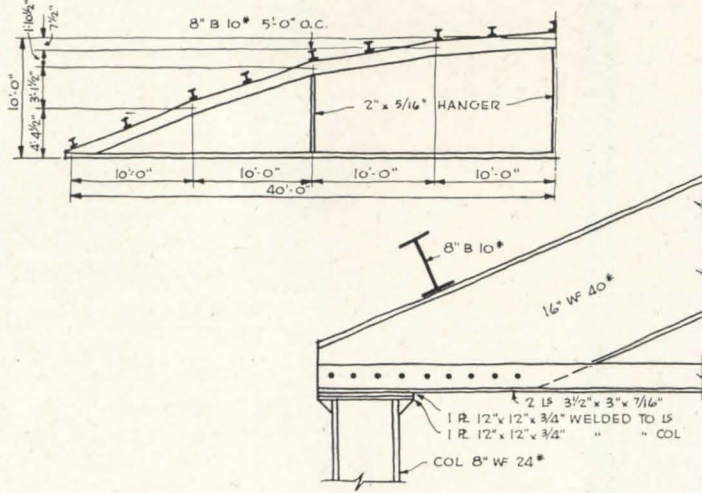

**80' TIED ARCH**  
DESIGNED FOR 50\* PER SQ. FT.  
(30\*LL - 20\*DL) AT 20' CENTERS

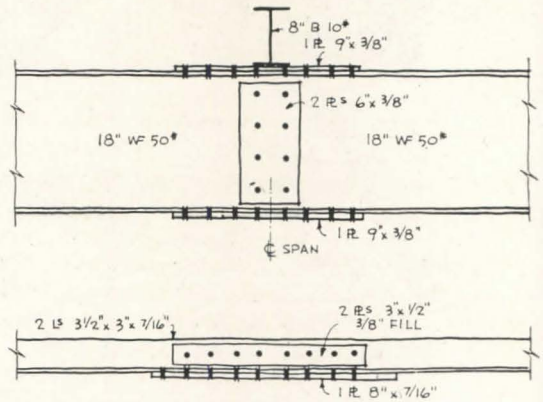
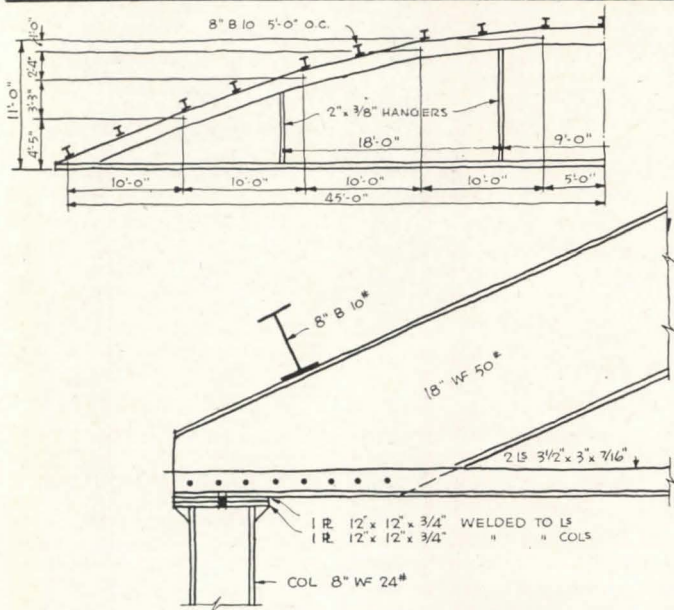

**90' TIED ARCH**  
DESIGNED FOR 50\* PER SQ. FT.  
(30\*LL - 20\*DL) AT 20' CENTERS

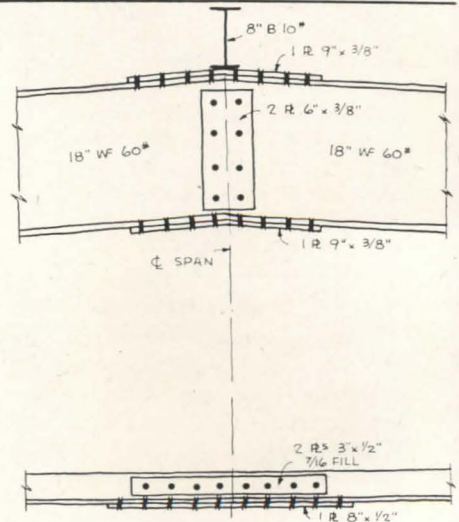
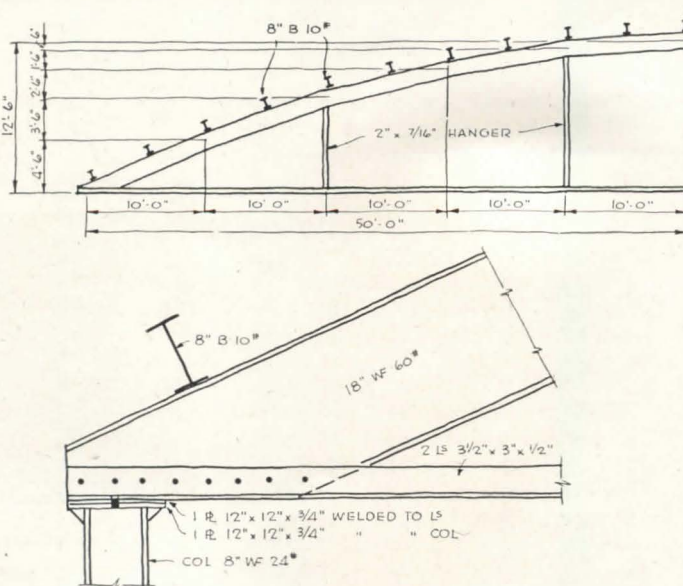

**100' TIED ARCH**  
DESIGNED FOR 50\* PER SQ. FT.  
(30\*LL - 20\*DL) AT 20' CENTERS



## PRODUCTS for Better Building

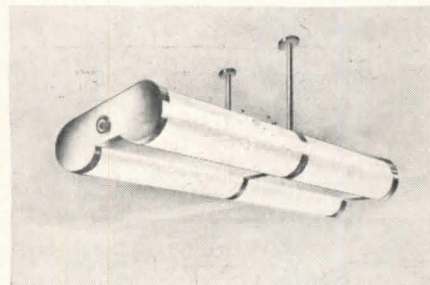
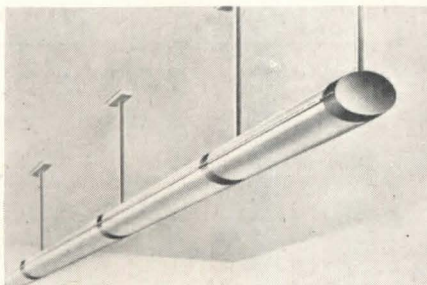
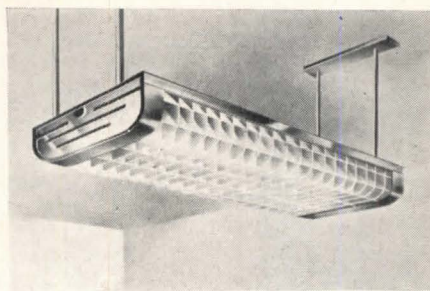

Shadowless, glareless lighting featured in prize-winning designs for schoolroom fixtures

### SCHOOLROOM LIGHTING

Prize-winning schoolroom fixture designs in Sylvania Electric's Third Annual Fluorescent Fixture Design Competition have been announced. First prize was won by Lynn L. Sweetland, Jr., for a fixture (top left) that distributes light directionally toward the front of the schoolroom, so that, with proper lighting layout, brightness contrast between fixture and ceiling is minimized. Second prize was won by Gerald E. Parks for a fully-louvered fixture (top right) in which side louvers are set at an angle to eliminate glare. Third prize went to Robert M. Francis for his design (bottom left) in which wiring and ballast housing are placed at the center, to distribute light evenly around the fixture and eliminate shadows on the ceiling. Warren W. Weiss won fourth prize for his design (bottom right) which features a rotating shield on either side for directed blackboard lighting or normal classroom lighting. Sylvania Electric Products, Inc., 500 Fifth Ave., New York, N. Y.

### DISPLAY LIGHTING

Several new types of lighting units have been especially designed for down-lighting in stores and display rooms. They employ spotlamps and floodlamps and are installed flush with the ceiling so that the light comes from an inconspicuous source. Baffles are provided to eliminate glare, but at the same time permit enough luminosity to avoid brightness contrasts between ceiling and

lighting unit. Three general types are available: a baffle downlight for general lighting; a directional downlight for accent lighting; and a counter downlight for projecting a long, narrow line of light on counter tops. Century Lighting, Inc., 419 W. 55th St., New York 19, N. Y.

### AIR CLEANER

Electrostatic precipitation is used by the *Trion electric air filter* to remove dirt, dust, smoke, and pollen from air supplied to domestic warm-air heating or air conditioning systems. Particles of dust and dirt in the air are electrically charged as they pass through an ionizing screen and adhere to collecting plates of opposite polarity. The unit consists of a metal cabinet, 50 $\frac{3}{4}$  in. high, containing a screen of fine wires (ionizing screen), a series of 59 parallel aluminum plates (collecting chamber), a power pack for supplying high voltage direct current, and a jet spray system for flushing collected dirt from the plates — required about once a month. At present two sizes are being manufactured; Model 100 with a 1200 cfm rating, for houses up to seven rooms; and Model 200, 1800 cfm, for houses up to 11 rooms. Trion, Inc., 1000 Island Ave., McKees Rocks, Penn.

### FLOORING

*Oaktred* is a composition flooring material composed of kiln-dried oak flour, asbestos fibers, and chemical binder, which is mixed with water and poured in place to form a permanent flooring. Installation is by the mason. Setting time is four to six days, after which it is

sanded and finished. Oaktred is said to have good insulating qualities and offer advantages of being resilient, seamless, and fireproof. Kompolite Building Materials, Inc., 111-115 Clay St., Greenpoint, Brooklyn 22, N. Y.

### WALL COVERING

*Fabron*, the fabric-plastic-lacquer covering for walls and ceilings, has been classified by the Underwriters' Laboratories, Inc., as a negative factor in the spread of fire when applied to unpainted plaster, and a negligible cause of smoke development. Frederic Blank & Co., Inc., 230 Park Ave., New York, N. Y.

### REDWOOD STAIN

A special stain for redwood clapboard and siding has been developed in cooperation with the California Redwood Association. Made with undiluted creosote oil, *California Redwood Stain* is said to increase resistance to decay, maintain color for years, or restore original color to old redwood. It may also be applied to other woods to give them a redwood appearance. Samuel Cabot, Inc., 101 Oliver Bldg., Boston, Mass.

### THERMOPANE CLIPS

A special type of non-corroding metal clip has been designed for use with double *Thermopane* units in standard punched steel sash. Basically, the clips are for units with two lights of  $\frac{1}{8}$ -in. thickness and  $\frac{1}{4}$ -in. air space, having overall standard thickness of  $\frac{7}{16}$  to  $\frac{9}{16}$  in.; and are adaptable to greater thickness when sash is specially punched. Libbey-Owens-Ford Glass Co., Nicholas Bldg., Toledo, Ohio.

### HOTEL BEDROOMS

An interesting design trend in the furnishing of hotel bedrooms is away from conventionally styled beds and toward the use of several lounge beds that serve as sofas during the day. The sofa bed is designed with a back that swings up, leaving an enlarged sleeping space about the size of a twin bed. Behind the back is space for storing a  
(Continued on page 136)



Couch, especially designed for hotel rooms, opens into comfortable bed



# Custom Lighting Results

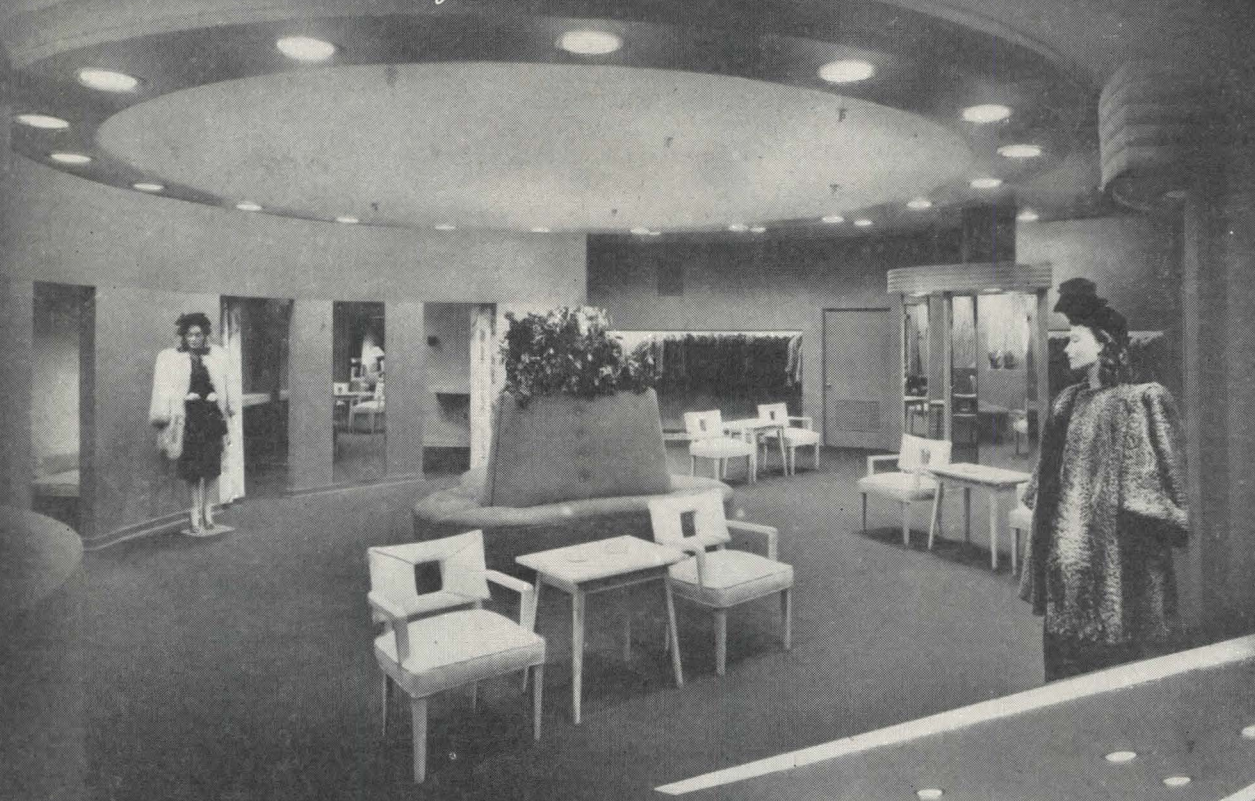

Pittsburgh Permaflector Fluorescent and Incandescent Units are going into more and more of America's outstanding stores, offices and buildings.

That is because these standard units produce custom lighting results—and offer the added advantages of high efficiency, easy installation and minimum maintenance.

Why not check this superior equipment before planning your next lighting installation?



A PERMAFLECTOR PORTRAIT  
Max Azen Furs  
Marks & Simboli, Reg. Architects  
Raphael Electric Co., Elec. Contractors

USE **PITTSBURGH**

PERMAFLECTOR LIGHTING EQUIPMENT



**PITTSBURGH REFLECTOR COMPANY**  
OLIVER BUILDING · PITTSBURGH 22, PA.

MANUFACTURERS OF FLUORESCENT AND INCANDESCENT LIGHTING EQUIPMENT  
DISTRIBUTED BY BETTER ELECTRICAL WHOLESALERS EVERYWHERE

**Permaflector Lighting Engineers in All Principal Cities**



## MANUFACTURERS' LITERATURE

### AIR CONDITIONING

**Amcoil Self-Contained or Remote Air Conditioning Units.** Descriptive booklet on two units — the Latenaire Conditioner for warm, humid climates, and the Sensaire Conditioner for warm, dry climates. Complete specifications and full description of each. Tabulated recommendations for selection of models for home, office, stores, restaurants, etc.; calculator chart. 12 pp., illus. Amcoil Air Conditioning, American Coils Co., 360-364 Thomas St., Newark 5, N. J.

### BUILDING WIRE

**U. S. Aluminum Building Wire Handbook.** A new booklet stressing the advantages claimed for aluminum wire, particularly in cost and current availability. Uses for the wire, test results, properties, tables showing the relative weights of various size aluminum and copper conductors. Joining and soldering methods. Typical solderless connectors. Tables of current carrying capacities, manufacturing dimensions, characteristics. 32 pp., illus. United States Rubber Co., 1230 Avenue of the Americas, New York 20, N. Y.

### CONCRETE FORMS

**(1) Atlas Labor-Saving Speed Forms for Walls and Slabs; (2) Atlas Labor-Saving Speed Floor Forms.** Description of steel form units erected by hand or in large panels handled by crane. Typical layouts for use, and photos of actual jobs. 4 pp. ea., illus. Irvington Form & Tank Corp., Irvington, N. Y.\*

### FLOORS

**The Aristocrat of Floors.** Humorous booklet describing the advantages of rubber floors in the home. Includes suggestions on how to get rubber flooring in either a new house or a remodeled one, and a list of eight manufacturers of rubber flooring. 28 pp., illus. The Rubber Manufacturers Assn., Inc., 444 Madison Ave., New York, N. Y.

### GYPSUM PLASTER

**Technical Information on Gypsum Plaster Base Coats and Finishes.** Full technical and fire test data on a line of base coat and finishing plasters. Includes plastering specifications, description of each product in the line, suggested use. 16 pp., illus. United States Gypsum Co., 300 W. Adams St., Chicago 6, Ill.\*

\* Other product information in Sweet's File, 1947.

### HEATING

**American Blower Industrial Heaters.** Catalog of industrial heaters, giving complete details of construction, installation information, etc., and including tables of steam heating capacities and steam conversion factors, dimensions tables, and a typical specification form for industrial heaters and accessories. Steam piping diagrams also included. 24 pp., illus. American Blower Corp., Detroit, Mich.\*

### Plan for Perfect Heating in Your Present Home — in Your New Home.

A booklet about home heating with all-electric heaters and furnaces. Home plans and photos illustrate built-in wall heaters, operating independently, in various types of house; portable heaters for occasional spot heating; and warm-air furnaces for central heating. 24 pp., illus. Electromode Corp., 45 Crouch St., Rochester 3, N. Y. 10 cents.

### KITCHENS

#### Youngstown Kitchens by Mullins.

Folder especially designed for architects, giving construction specifications and dimensional details of Youngstown kitchen units, and 12 possible kitchen arrangements. Equipment includes the Kitchen-aider cabinet sink, and wall and base cabinets, all of steel. 6 pp., illus. Mullins Mfg. Corp., Warren, Ohio.\*

### LANDSCAPING

**Industry Need Not be Ugly.** Booklet of photos showing successful landscaping of industrial plant grounds, with comments by plant executives on benefits to be derived from careful landscaping. 12 pp., illus. National Landscape Nurserymen's Assn., Box 313, Niles, Mich.

### LIGHTING

#### The "General" Idea is Simple.

Catalog of lighting fixtures for display windows and store interiors, including accent lights, goosenecks, fixed ceiling and wall mounts, special fixtures for high-ceilinged rooms, gooseneck desk and table lamps, recessed fluorescents, showcase strips, etc. 16 pp., illus. General Lighting Co., 32 Union Sq., New York 3, N. Y.

### MARBLE

**Marble Forecast: Availability of Foreign and Domestic Marbles.** Second annual forecast of marbles available and in production. Lists each company's offerings, with notes as to quantities available. Gives complete list of members of Marble Institute of America and

a list of importers of foreign marbles. Classifies marbles by color, and describes the four classifications adopted by the Institute for standardization purposes. 8 pp., illus. Marble Institute of America, 108 Forster Ave., Mt. Vernon, N. Y.

### MERCHANDISING

**Methods of Merchandising Presentation.** Manual of merchandise display arrangements and fixtures, methods of figuring hardware and glass requirements, class cutting instructions, utilization of space above the counters, merchandising requirements of special departments. Includes catalog of a line of standards and brackets, bins and other equipment. 46 pp., illus. Reflector-Hardware Corp., Western Ave. at 22nd Pl., Chicago 8, Ill.

### PLASTICS

**Textolite Laminated Plastics.** New bulletin giving the complete story of G-E Textolite laminated plastics; more than 50 grades described, each with its own special combination of properties. Forms in which Textolite plastics are supplied. Suggested applications. 64 pp., illus. Plastics Division, General Electric Co., 1 Plastics Ave., Pittsfield, Mass.\*

### ROOF TRUSS

#### A Welded Bow String Roof Truss.

Article describing the structural framework for a 72-ft. clear span roof supported on masonry walls featuring arc welded bowstring roof trusses used in combination with an insulated steel deck. Technical details, diagrams. 4 pp., illus. The Lincoln Electric Co., Cleveland 1, Ohio.

### STOKERS

#### Types LR and LR1 Ram-Feed Stokers (Bulletin S-32).

Bulletin on two types of stokers with capacities of 75 to 315 boiler h.p., featuring automatic air volume control and intermittent coal feed control. Cross-sections, construction information, advantages claimed. 8 pp., illus. The Brownell Co., Dayton 1, Ohio.

### TRACING CLOTH

#### Arkwright Tracing Cloth for Ink or Pencil Drawings.

Samples and specifications of four types of tracing cloth for ink or pencil drawings. Samples adequate for testing and comparison. Arkwright Finishing Co., Providence, R. I.

### WALL TREATMENT

**Hydroclide Colorless.** Folder on an invisible water-repellent treatment for exterior concrete and masonry building walls above grade. Includes test data, advantages claimed, method of application. 4 pp., illus. Building Products Division, L. Sonneborn Sons, Inc., 88 Lexington Ave., New York 16, N. Y.\*

(Continued on page 150)



My first choice  
is radiant heat!



My first choice  
is convection heat!



## Modine Convactor Radiation gives you these two heating principles blended into one!

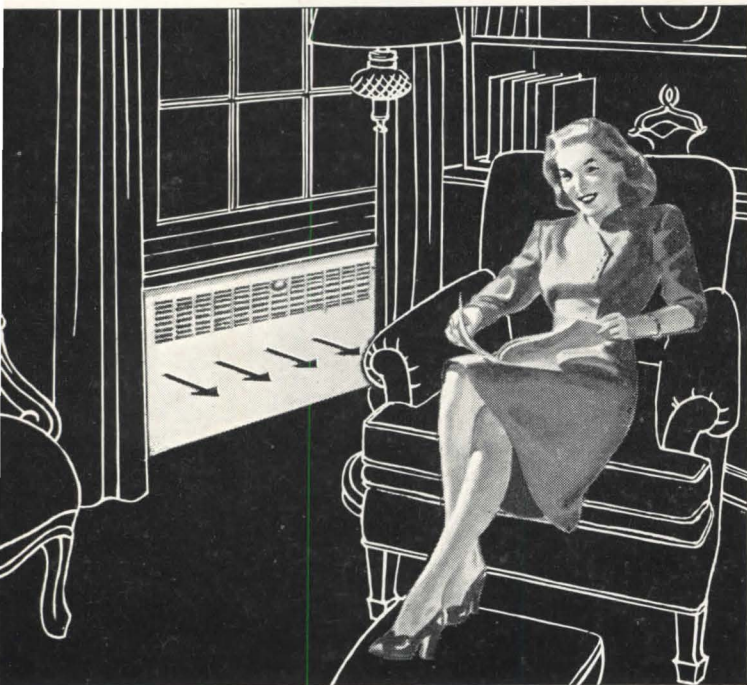

1

### RADIANT HEATING

Mild, radiant heat in just enough quantity to offset heat loss from window areas — that's what those arrows represent, coming from the Modine Convactor Panel below the window. To this we add . . .

2

### CONVECTION HEATING

Warmed air circulated by Convection Heating. Hot water or steam passes through copper heating unit which draws cooler, floor-line air into bottom of convactor where it's warmed, rises and then passes out through grille.

**Result:** Dependable new heating comfort for moderate cost homes and apartments . . . distinctive room charm and cleanliness without unsightly radiators! Yes, Modine Convactor Radiation provides a modern, blended heating system for modern living — a heating system that makes possible individual room control — that responds almost instantly to sensitive automatic controls — that gives you gentle air circulation without the use of moving parts that wear out. If you're planning to build or modernize, think of Modine Convactor Radiation . . . look for Modine's representative in the "Where-to-Buy-it" section of your phone book . . . or send in coupon below for new, free Convactor Booklet! MODINE MANUFACTURING CO., 1773 Racine Street, Racine, Wisconsin.



MODERN  
BEAUTY

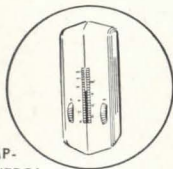

CLOSE TEMP-  
ERATURE CONTROL



EASY TO  
INSTALL

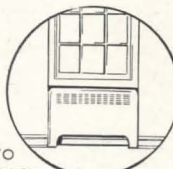

ADDS TO  
LIVING SPACE



PRICED  
FOR TODAY'S  
HOMES AND  
APARTMENTS

# Modine

## CONVECTOR RADIATION

The Modern "proved by use" heating method

Modine Mfg. Co., 1773 Racine St., Racine, Wis.  
I want your new free booklet containing complete information on Convactor Radiation. Please send it to:  
NAME \_\_\_\_\_  
ADDRESS \_\_\_\_\_  
CITY \_\_\_\_\_  
STATE \_\_\_\_\_



**THE RECORD REPORTS** (Continued from page 18)

building; the Army Medical Museum and Center Administration building; Central Laboratory Group buildings; and the Army Institute of Medicine and Surgery. A working library, animal farm, quarters for the staff and other buildings also are included in the plans.

**VA Regional Office**

A 10-story regional office building recently completed for the Veterans Administration in Wilkes-Barre, Penn.,

required only nine months to build. Lacy, Atherton, Wilson & Davis of Wilkes-Barre were the Architects and Engineers.

The building was especially designed to meet VA needs. Private offices are provided by removable metal partitions, and the entire area in back of the elevators is left undivided on each floor. Of reinforced concrete construction, the building cost approximately \$1,120,000, contains approximately 1,850,000 cu. ft.



VA Regional Office Building, Wilkes-Barre

**More USABLE floor space  
at LESS COST!**

Richards-Wilcox No. 719 Vanishing House Door Hanger and wood lined track installation in ordinary 2 x 4 studded house partition, showing application of hanger and track to header and door.

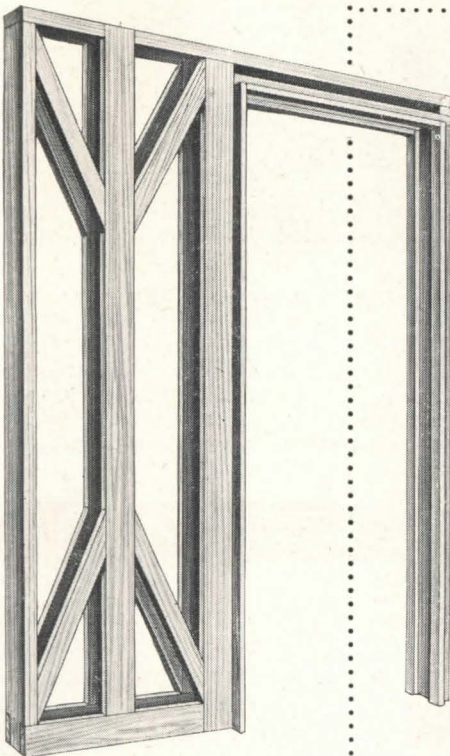
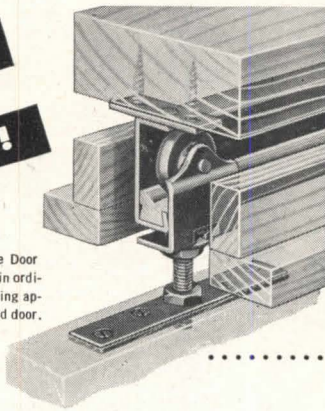

**with R-W Residential  
Vanishing Door Hangers**

Designed for use in 2" x 4" Studded Walls!

Present-day home building costs require maximum use of all available floor space. That is why Richards-Wilcox Vanishing (sliding) House Doors are now more popular than ever. Floor space "wasted" due to the swinging arc of hinged doors can be fully utilized with vanishing doors . . . furniture, pictures, lighting fixtures can be located conveniently and correctly.

And with R-W Vanishing House Doors there is no extra construction cost! The R-W "Ordinary Wall" pocket permits installation of vanishing doors in standard 2" x 4" studded partitions. Get complete details from your nearest Richards-Wilcox office—free consultation available without obligation.

(Above) Mill construction of R-W designed "Ordinary Wall" pocket for installing vanishing house doors operating on R-W No. 719 house door hangers in ordinary 2 x 4 studded partition. This construction, developed by Richards-Wilcox engineering department, solves the problem of builders and architects who desire to get the advantages of "Richards-Wilcox" Vanishing House Doors without increasing the width of the ordinary 2 x 4 studded partitions.

The exterior is faced with common red brick, trimmed with Indiana limestone. Windows are steel, projected type. Main entrance trim and base are verde antique polished marble; main doors are all glass, with metal trim.

**Housing Projects**

FHA has approved mortgage insurance financing totaling \$27,500,000 for the construction of 3010 rental homes by the American Community Builders, Inc. of Chicago. Construction on the 2400-acre site located on the Cook-Will County line between Chicago Heights and Matteson was begun last month and the first houses are expected to be completed early in 1948. The rental development is the first step in the company's plan for a completely new satellite city. It will include 2800 two- and three-bedroom units in multiple family "town and country" houses and twin houses; 200 will be one-bedroom units. Each dwelling will have a full basement and its own front and back yards. A "toy-yard" for each 15-20 homes will be provided. Loebel, Schlossman and Bennett of Chicago are the architects.

Construction is under way on 86 two-family brick veneer houses in the Ivy Hill veteran housing project in Newark, N. J. The 50-acre tract will provide homes for 1000 veterans and their families when completed, plus several stores and a bus terminal. Plans were developed by Arthur H. Padula, vice president of the Fairmount Construction Co., builders of the project.

Construction also has been started on a garden-type apartment project in Astoria, 15 minutes from Times Square, New York City. To be called the Marine Terrace Apartments, it will consist of three main sections, the first housing 405 families, the second 393, and the last 540. Exteriors will be brick; all apartments will have cross ventilation

(Continued on page 128)

1880  1947  
OVER 67 YEARS

**Richards-Wilcox Mfg. Co.**

"A HANGER FOR ANY DOOR THAT SLIDES"  
AURORA, ILLINOIS, U.S.A.

- Branches: New York Chicago Boston Philadelphia Cleveland Cincinnati Washington, D.C.  
Indianapolis St. Louis New Orleans Des Moines Minneapolis Kansas City  
Los Angeles San Francisco Omaha Seattle Detroit Atlanta Pittsburgh





*for industrial plumbing*

**Crane meets every requirement**

Shown here are just a few of the many Crane fixtures designed for industry. The broad Crane line meets every plumbing requirement . . . for large plants and small . . . for office and for factory.

Whatever fixtures you select, you can be sure they're built to stand tough usage . . . they're easy to clean . . . they provide proper sanitation. And you can count on this—the name Crane is better known to your clients than any other name in plumbing.

For a description of the Crane line now in production, refer to your copy of "Crane Service for Architects." If you are still without one, ask your Crane Branch for a free copy.

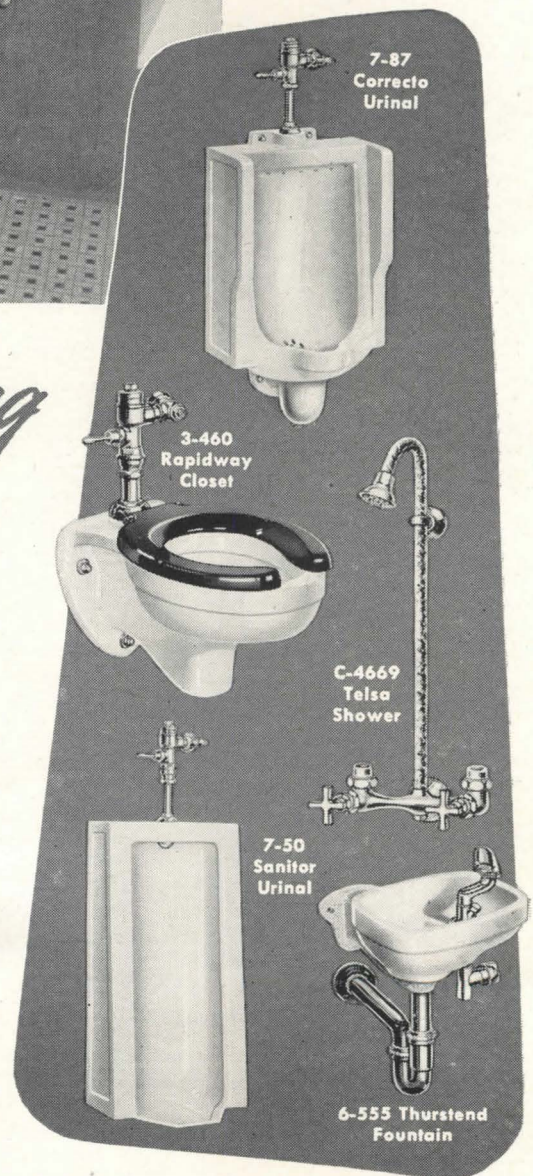

**CRANE**

CRANE CO., GENERAL OFFICES:  
836 S. MICHIGAN AVE., CHICAGO 5  
PLUMBING AND HEATING  
VALVES • FITTINGS • PIPE

NATION-WIDE SERVICE THROUGH BRANCHES, WHOLESALERS, PLUMBING AND HEATING CONTRACTORS



## THE RECORD REPORTS (Continued from page 126)

and entrance foyers. Samuel Paul and William M. Dowling are architects for the project, being built by The Roth-Schenker Corp. of New York City.

### ATELIER FOUNDED

Under the direct sponsorship of the Newark chapter of the New Jersey Society of Architects, an Atelier has been founded for the purpose of training returning war veterans in architectural drafting and design. Guided by Earnest

H. Fougner and other members of the Newark Chapter, who act as critic-instructors, and with the support of Philip H. Haney and Harry C. Stephan of the Essex County Vocational School, the Atelier has progressed during the past 18 months to an enrollment of approximately 30 students in regular attendance. Attendance is limited by the size of present quarters, and a long waiting list has built up. Two of the students already have gained their

State Architect's License.

It is the belief of the Newark chapter that this Atelier will become a permanent institution which will definitely be an asset to the architectural profession. To this end, the chapter intends to provide the most efficient tutelage possible by introducing new methods of construction coupled with the latest development in materials, construction methods and design. The chapter recently sponsored a competition to further the work of the Atelier.

### ROME FELLOWSHIP

The American Academy in Rome has announced the award of the Rome Prize Fellowships, the first to be given since 1940. Winners in architecture were: Frederic S. Coolidge, of Cambridge, Mass., holder of a B.S. (1940) and a B. Arch. (1946) from Harvard; and Charles D. Wiley of Chicago, who received his B.A. from the University of Minnesota in 1940 and his M.A. from Harvard in 1941, and is currently with the Chicago architectural firm of Skidmore, Owings & Merrill. Miss Ilse Meissner, a graduate of Pratt Institute in 1946, was given honorable mention and named first alternate. Honorable mention also went to William Breger, Harvard, 1945.

The Fellowships are for one year each, beginning October 1, 1947, with a possibility of renewal. The total estimated value of each is about \$3000.

Staff in residence at the Academy for the coming academic year will include Laurance P. Roberts, director; Lamont Moore, assistant director; and George Howe, architect.

### AT THE COLLEGES

#### School Accrediting

At its 1947 annual meeting, the National Architectural Accrediting Board took action to the effect that beginning with the publication of the 1949-50 list, no school will be accredited, the completion of whose curriculum involves less than five years of post-high school education. Notice of this action is to be included on the 1947-48 list, and those schools now offering four-year courses are to be so designated.

Eleven of the 16 schools appraised this year had four-year curricula in 1945. Of these 11, five already have five-year curricula in operation, and three more have indicated that they will institute them next year.

#### Conference Held

A Conference on Community Planning was held at Columbia University, New York City, on June 26 under the joint sponsorship of the University and The Russell Sage Foundation. Purpose was "to clarify and to evoke suggestions from representatives of related fields as

*(Continued on page 130)*



## architects appreciate

... the many advantages of Amtico Rubber Tile. Designed to meet their exacting specifications, Amtico Rubber Tile is the ideal flooring for public and private buildings, where long-lasting beauty and silence are a primary consideration.

Resistant to cigarettes and other blemishes, it is easy to clean, reducing maintenance costs to a minimum. Banks, airports, hospitals, libraries and streamlined trains offer visible proof of Amtico Rubber Tile's ability to look well under many tramping footfalls.

Thirteen beautiful, marbled colors make possible many interesting floor designs, and our greatly increased capacity assures prompt delivery. Write for illustrated folder and samples.

**AMERICAN TILE & RUBBER CO.**  
TRENTON, NEW JERSEY



# FOR HOSPITALS OF DISTINCTION:

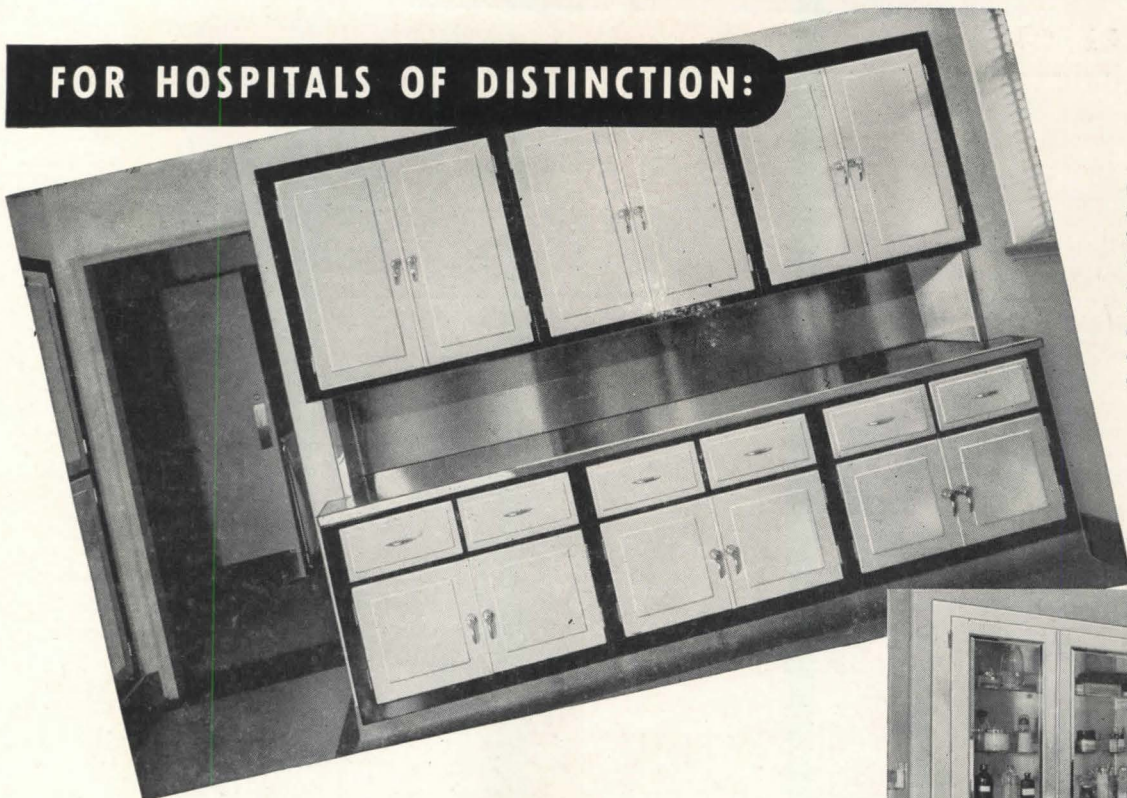

Counter-type storage cabinet in unsterile workroom of Central Service Department. Adjustable stainless steel shelves, metal doors. Stainless steel counter top, back and end splashes.

## SCANLAN-MORRIS *Recessed Cabinets*

Authentic Guidance and Assistance  
Available to Architects, Without Obligation

• Storage of supplies and materials in the modern hospital is greatly facilitated by the installation of Scanlan-Morris Recessed Cabinets—engineered to fit requirements.

Many years of direct contact with hospital superintendents, surgeons and architects, qualify the Scanlan-Morris Technical Sales Service Department to supply valuable assistance and authentic guidance in such installations—backed by more than 40 years of experience in designing and manufacturing hospital and surgical equipment (not only cabinets but also surgical lights, complete sterilizing equip-

ment and other hospital equipment). Scanlan-Morris Recessed Cabinets are made in styles and sizes as required to serve the needs of the various hospital departments. Cabinet bodies are made of heavy-gauge steel, with double-lapped and sweated seams, insuring sturdy, dust-proof construction; frames are electrically-welded flat steel; doors and shelves may be of glass or metal, counters and shelves of stainless steel or other metal, as specified.

Mail the coupon for detailed information or submit your problems with floor plans for layout suggestions, without obligation.



Recessed supply cabinet in septic operating room



Recessed cabinet in maternity department. Upper section open and fitted with adjustable stainless steel shelves for holding mothers' treatment trays.

# Ohio Chemical

MANUFACTURERS OF MEDICAL APPARATUS,  
GASES AND SUPPLIES FOR THE PROFESSION,  
HOSPITALS AND RESEARCH LABORATORIES



THE OHIO CHEMICAL & MFG. CO.

1400 East Washington Ave., Madison 3, Wisconsin

Represented in Canada by Oxygen Company of Canada, Limited, and Internationally by Airco Export Corporation, 33 West 42nd Street, New York

BRANCH OFFICES IN PRINCIPAL CITIES

THE OHIO CHEMICAL & MFG. CO.  
1400 E. Washington Ave., Madison 3, Wis.

Send information on  Scanlan-Morris Recessed Cabinets  
(Please attach professional card or letterhead)

Name .....

Address .....

City..... State..... AR



to what and how each field can best contribute to the integration of the respective knowledges leading to good physical planning of the community within this frame of reference."

Hugh R. Pomeroy, Director, Department of Planning, Westchester County, N. Y., served as chairman of the Conference. Speakers were: Dr. Charles S. Johnson, President-elect, Fisk University; Dr. Harold M. Mayer, Chief, Division of Planning Analysis, Philadelphia

City Planning Commission; Dr. Edwin H. Spengler, Associate Professor of Economics, Brooklyn College; Le Corbusier, Architect and Town Planner, French Representative, U.N. Board of Design; Albert Mayer, Architect, New York City; and Lewis Mumford, author and critic.

**Prizes Announced**

Winners of the Traphagen Prizes for an original plan for the first American



Traphagen prize-winners (left to right): William D. Wilson, second; William L. Bottomley, head of B.A.I.D. panel; Charles E. Stade, first; John K. Sinclair, third

University of Fashion were: first, Charles E. Stade, Park Ridge, Ill.; second, William D. Wilson, Louisville, Ky.; third, John K. Sinclair, Williamstown, Mass. All three are graduate students in architecture at Princeton University and veterans of World War II. The competition was sponsored by the Beaux-Arts Institute of Design.

A team of four students in the College of Architecture, Cornell University, was awarded first prize in a nationwide competition for the modernization of a shopping center, sponsored jointly by the New York chapter of the A.I.A. and the Store Modernization Show held last month in New York City. The members of the winning team were Blake Allen of White Plains, N. Y., leader; Olaf W. Shelgren, Jr., Buffalo, N. Y.; Miss Alberta J. Cassell, Washington, D. C.; and Eugene M. Bertin, Rochester, N. Y. Their entry consisted of plans and models for the modernization of a group of stores in Ithaca, N. Y.

**Review Courses**

Refresher and review courses for Architects Registration Examinations will be given at the Federation Technical Institute, 5 Beekman St., New York 7, N. Y., beginning Monday, September 22. The courses offered, all of them evening, are: mechanical equipment of building; electrical and elevators; structural design — steel; structural design — concrete; design and planning; history of architecture; building materials and methods of construction; architectural practice; and preparing for an R.A. exam. For further information address Earl H. Strunk, Director of the Institute, at the above address.

**New Bulletin**

A new bulletin, "How to Build a House of Concrete or Concrete Masonry," has been published by the Low-Cost Housing Research Engineering Experiment Station of Louisiana State University. Prepared by O. J. Baker, the 8-page illustrated pamphlet gives basic information on concrete masonry, exterior finishes, painting, construction, etc. Copies may be obtained free of

(Continued on page 132)

IMPLEMENT OF ARCHITECTURE

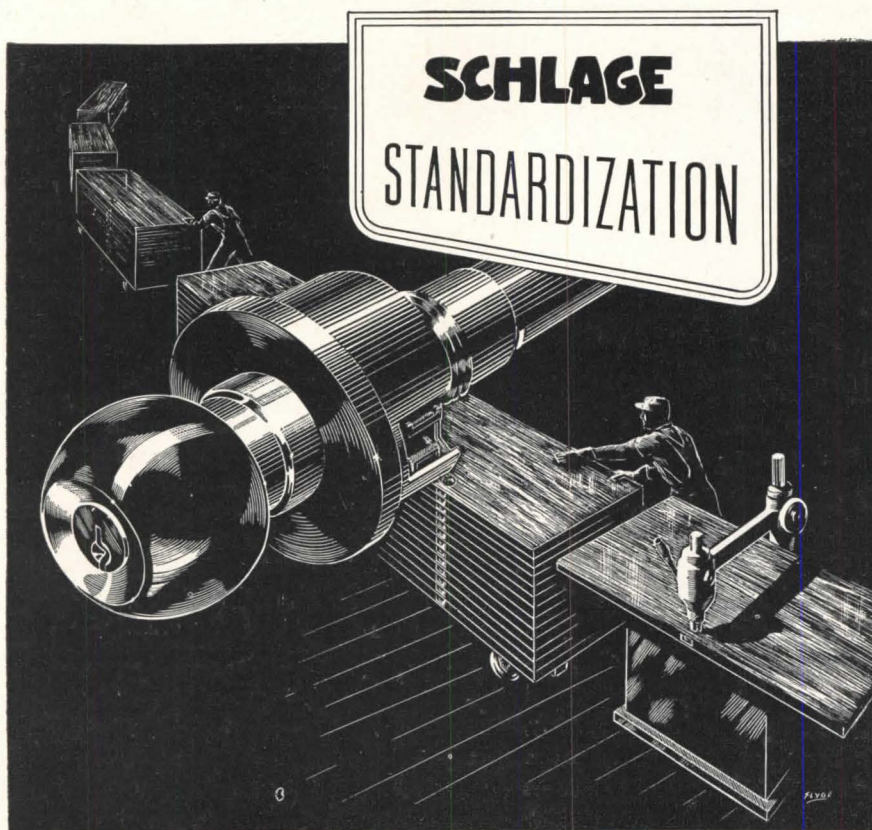

The standardized chassis of Schlage locks permits the boring of all doors at once for economy of installation. Schlage standardization also simplifies the architect's specification job as it allows locks to be reversed or interchanged if plans change during construction.

**SCHLAGE**  
**LOCK COMPANY**  
 SAN FRANCISCO • NEW YORK

ORIGINATORS OF THE CYLINDRICAL LOCK



# BURNHAM BOILERS SPELL

*Dependability and Efficiency*

## FOR EVERY TYPE OF

residential



institutional



and commercial

## INSTALLATION

**BURNHAM DE LUXE**  
*For Oil Only*—Designed for highest efficiency at minimum operating cost. A vertical fire-travel boiler with combustion chamber completely surrounded by water. Heat absorbing fins avoid heat waste.

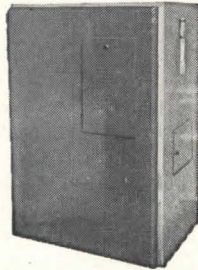

**BURNHAM YELLO-JACKET**  
*For Automatic Firing—Oil, Gas, Stoker.* Famous for its low-cost operation and dependability. Large combustion space to assure rapid heat absorption. Sections with heat grabbing fins. Built-in heaters for year 'round automatic hot water.

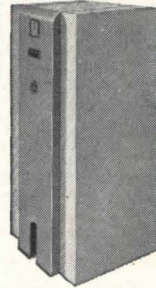

**BURNHAM SQUARE SECTIONAL—17"-21"-27" Series**  
*For All Fuels*—Designed for medium and large homes and buildings. Tube type construction establishes higher operating efficiencies on hand-fired coal or automatically fired boilers. Famous "three times back and forth fire-travel—the big fuel saver!"

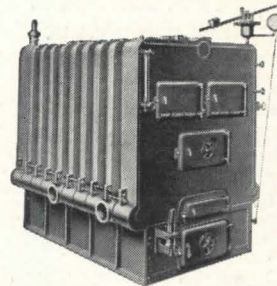
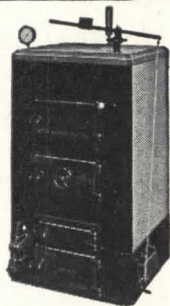

**BURNHAM SQUARE SECTIONAL—36"**  
*For All Fuels*—A larger version of boiler at left—for large dwellings and buildings. Same extended fire-travel—same fuel saving efficiency—same heat absorbing design. Unjacketed. A popular and highly satisfactory heating unit.

**BURNHAM SQUARE SECTIONAL—50" TWIN**  
*For All Fuels*—A husky boiler built in twin sections. For apartment houses, hotels and other public buildings. Twin grate assembly. A superior boiler that will deliver maximum heat at lowest cost. 80 inches high overall; 71 inches wide.

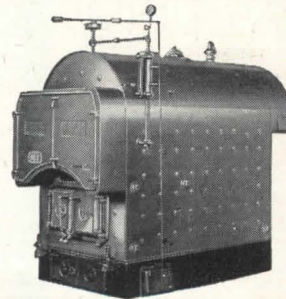
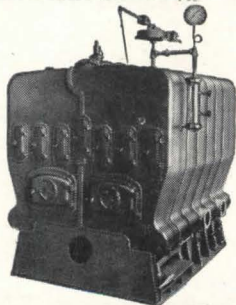

**BURNHAM WELDED STEEL (Compact Series)**  
*For Coal, Oil, Gas and Stoker*—Famous Burnham extended fire-travel—3 times length of boiler. High boiler efficiency—low flue temperatures. There's no better designed boiler of this type construction. Conforms with ASME Code and SBI Code for low pressure boilers.



Steadily increasing production has placed us in a position to make reasonably prompt deliveries on most styles and sizes. Let us know your requirements.

**MAIL THIS COUPON TODAY!**

*Burnham Corporation*

BOILERS and RADIATORS  
IRVINGTON, N. Y., Dept. AR87



Burnham Corporation Dept. AR87  
Irvington, New York  
I am interested in your \_\_\_\_\_ (fill in type here)  
Boiler. Please send booklet.  
Name .....  
Address .....  
City ..... State .....



## THE RECORD REPORTS (Continued from page 130)

charge from Low-Cost Housing Research, Engineering Experiment Station, Louisiana State University, Baton Rouge 3, La.

### Appointments

John Knox Shear, 1938 graduate of the Department of Architecture, Carnegie Institute of Technology, has been named associate professor and assistant head of the Department of Architecture, effective September 1.

T. Keith Glennan, an executive of Anasco Division of General Aniline & Film Corp., and wartime director of the U. S. Navy Underwater Sound Laboratory, has been named president of Case Institute of Technology, Cleveland, Ohio.

### Wood Decay Survey

A state-wide study of the factors influencing wood decay, under conditions of modern construction, has been

initiated by the New York State College of Forestry at Syracuse University. The study will be under the direction of Dr. Ray R. Hirt, forest pathologist of the College.

The project will include the study of wood decay in year-around dwellings, summer homes, storage plants, office and industrial buildings, etc. The problem of modern wood preservatives in relation to the control of decay in new lumber as well as in timbers already in service, will form an important part of the investigation.

### CONTEST

The Philadelphia Art Alliance, sponsor in Philadelphia of the American National Theater and Academy, has announced a model stage set contest with a first prize of \$100, a second of \$50, and an honorable mention of \$10.

Any classic or contemporary play may be chosen for the model set, but the set must be entirely original. Sets must be delivered to the Art Alliance on Sunday, Nov. 16, will be exhibited there through Dec. 7. For further information, address The Art Alliance, 251 S. 18th St., Philadelphia 3, Penn.

### PROGRAM FOR COST STABILIZATION

The Governing and Advisory Boards of The Associated General Contractors of America have made the following recommendations to general contractors in an effort to help stabilize construction costs:

"1. Where it is the normal custom of the contractor, and to the fullest extent possible, firm prices should be quoted to the owner. Contractors should require firm prices from subcontractors and sellers of materials and machinery.

"2. Fair and just wages should be paid to workmen, and all possible steps should be taken to encourage workmen to produce a day's work for a day's pay, to maintain wage rates for agreed upon periods of time, to settle disputes without stoppage of work, to eliminate wasteful practices, and to permit the training of adequate numbers of apprentices.

"3. All possible steps should be taken to improve efficiency of management.

"4. Where possible, owners should be discouraged from demanding the completion of projects at speeds which require overtime work at premium rates of pay, or procedures requiring extra costs."

### OFFICE NOTES

#### Offices Opened, Reopened

Jack J. Buchter, Architect, has announced the opening of his office in the Dykes Bldg., 41 Moraga Highway, Orinda Crossroads, Calif., for the general practice of residential and commercial architecture.

*(Continued on page 134)*

# Where **DURIRON** fits into your plans for schools and colleges

If your plans for schools or colleges include chemical laboratories, you can insure against costly, future replacements by specifying Duriron for drain pipe and fittings, sink strainers and traps.

Duriron, with its complete indifference to corrosive agents, lasts indefinitely in the chemical laboratory. A high silicon iron, Duriron is uniformly corrosion resistant throughout the thickness of the metal. It possesses structural strength for installation by the usual methods of plumbing practice, being calked in the same manner as cast iron soil pipe.

Write for *new* bulletin 703 which describes Duriron equipment for the laboratory in detail.

**THE DURIRON CO., INC.**  
DAYTON 1, OHIO

Branch offices in principal cities





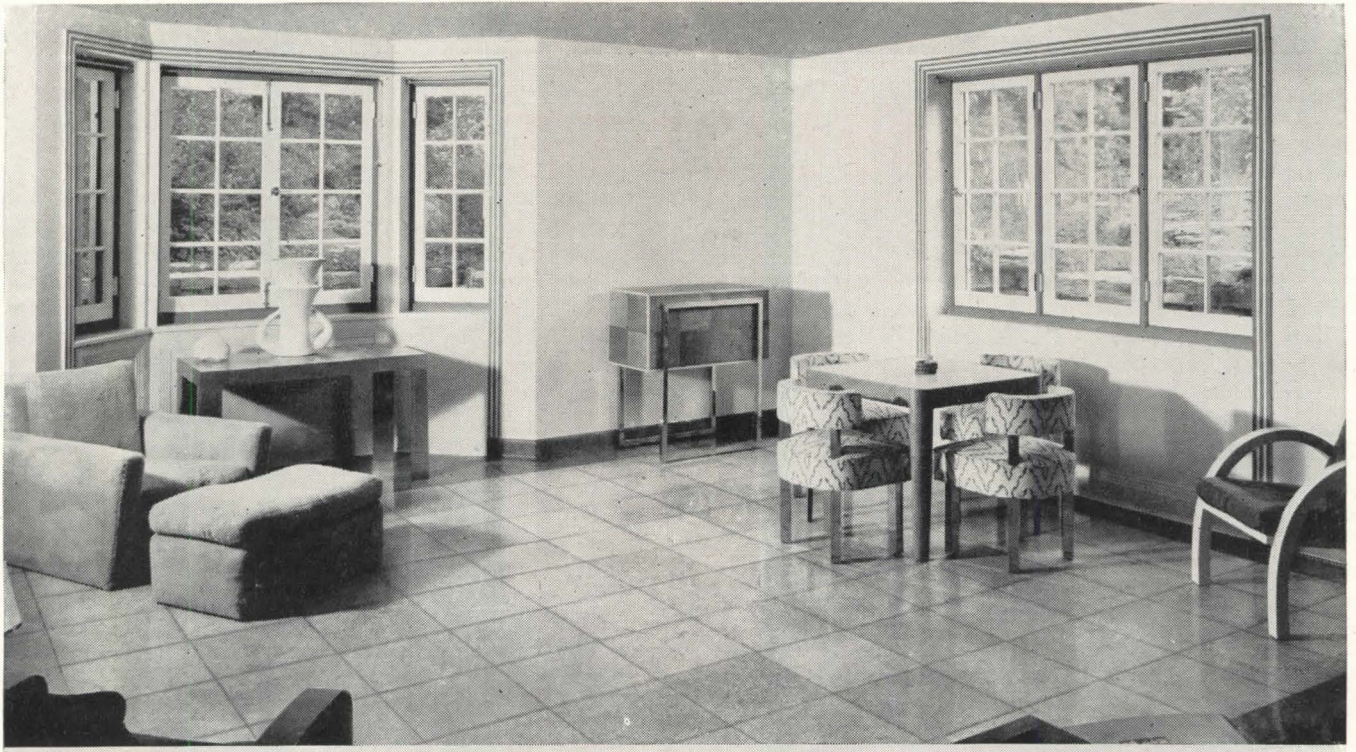

## There's No Premium On Light!

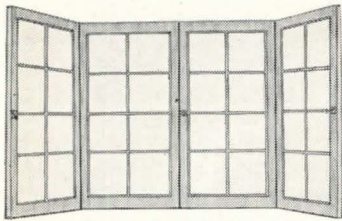

*Ponderosa Pine casements add warmth and friendliness to modern interiors. These casements are made up in stock designs, with frames, to answer a wide variety of window needs.*

*Research has proved that stock windows of wood are famous for their efficiency, low maintenance and low cost. Ponderosa Pine windows are easily weather-stripped. They are quiet windows—permitting minimum vibration. Stock design frames are precision made, properly seasoned and dried, with joints made to stay tight.*

Plenty of outdoor light for the homes you plan need not be costly . . . or impractical . . . when you specify stock design windows of Ponderosa Pine.

You can use these precision-made windows generously, knowing that their clean design and good proportions will add character and friendliness to room interiors—at no cost penalty. Installation costs less because of the wide variety of Ponderosa Pine window types and sizes that fit every kind of construction. Maintenance will be low because smooth-grained Ponderosa Pine holds paint so firmly. Remember, too, that Ponderosa Pine has natural insulating qualities—does not transmit cold or heat, thus helping to keep rooms warmer in winter and cooler in summer.

In planning window groups, bays or corner windows, you'll find "Today's Idea House"—32-page Ponderosa Pine booklet—a valuable aid. This booklet, profusely illustrated with photographs, is yours for the asking. Mail the coupon!

*For Friendly Living . . .*

**Ponderosa Pine**  
**WOODWORK**



Ponderosa Pine Woodwork  
Dept. PAR-8, 111 West Washington Street  
Chicago 2, Illinois

Please send me a free copy of "Today's Idea House."

Name .....

(Please Print)

Address .....

City ..... Zone ..... State .....



## THE RECORD REPORTS *(Continued from page 132)*

Elmer J. Fox, Architect, has announced the opening of his new offices in Consumer's Bldg., 220 S. State St., Chicago 4, Ill.

Ben B. Milam, Lt. Col., C.E., having been relieved from active duty, is resuming the general practice of architecture with offices in the Guaranty Bldg., Galveston, Texas.

The Office of Harold J. Perry, Architect, has been opened at 16 Bloomfield Ave., Flemington, N. J.

### New Addresses

The following new addresses have been announced:

Gregory Ain, Architect, Joseph Johnson and Alfred Day Collaborating, 2404 W. 7th St., Los Angeles 5, Calif.

American Houses Inc., 165 W. 46th St., New York 19, N. Y.

Cortland Engineering Co., Structural Engineers, 5 Beekman St., New York 7.

Gordon Drake, Designer, 4201 Sunset Blvd., Los Angeles 27, Calif.

Foster & Yasko, Architects (George Foster and Karel Yasko), 407 Scott St., Wausau, Wis.

P. M. O'Meara Associates (G. J. Maguolo and G. E. Quick, Architect-Engineer), Cincinnati office, 936 Temple Bar Bldg., Cincinnati 2, Ohio.

Frederic Hutchinson Porter, A.I.A., Architect, R. Walter Bradley, Associate, 1009 E. Lincoln Highway, Cheyenne, Wyo.

Simons & Lapham, Architects (Albert Simons, F.A.I.A., and Samuel Lapham, F.A.I.A.), 17 Broad St., Charleston, S. C.

Hugh Stubbins Jr., Architect, 103 Pleasant St., Lexington, Mass.

### Firm Changes

Bates & Rogers Construction Corp., 111 W. Washington St., Chicago 2, Ill., has announced that Frederic L. Copeland, vice president, will reopen their western office in the San Francisco area on or about September 1. The firm also has announced the election of the following officers with headquarters in Chicago: John W. Rogers, vice president and treasurer; George N. Martin, vice president; Lee J. Bullen, vice president; and E. J. Million, secretary and assistant treasurer.

Richard M. Bennett, former chairman of the Department of Architecture, Yale University, has been admitted as a partner in the firm of Loebel and Schlossman, Architects-Engineers, 333 N. Michigan Ave., Chicago, Ill., and the name of the firm has been changed to Loebel, Schlossman and Bennett.

L. W. Cook and R. A. Zern have formed a partnership to be known as Cook and Zern, Consulting Engineers, specializing in the design of structural frames and foundations. Address: 607 Wabash Bldg., Pittsburgh 22, Penn.

Flynn E. Hudson, Jr., A.I.A., and J. Paul Gilmore have announced formation of a partnership for the practice of architecture and engineering under the firm name of Hudson and Gilmore, Architects and Engineers, with offices at 203 Bartlett Bldg., Montgomery, Ala.

Roy E. Lane, A.I.A., has joined the staff of Bozell & Jacobs Advertising Agency in Dallas, Texas, as technical advisor to the agency's clients dealing in building, construction and manufacturing.

### CORRECTION

In publishing "Six Ranch Houses for Modern Living" (ARCHITECTURAL RECORD, April, 1947, pp. 82-87), the word "architect" was used erroneously with Cliff May's name. Cliff May is not a registered architect, but a builder of California ranch houses. And the excellent renderings should have been credited to "Chris" Choate, Registered Architect.

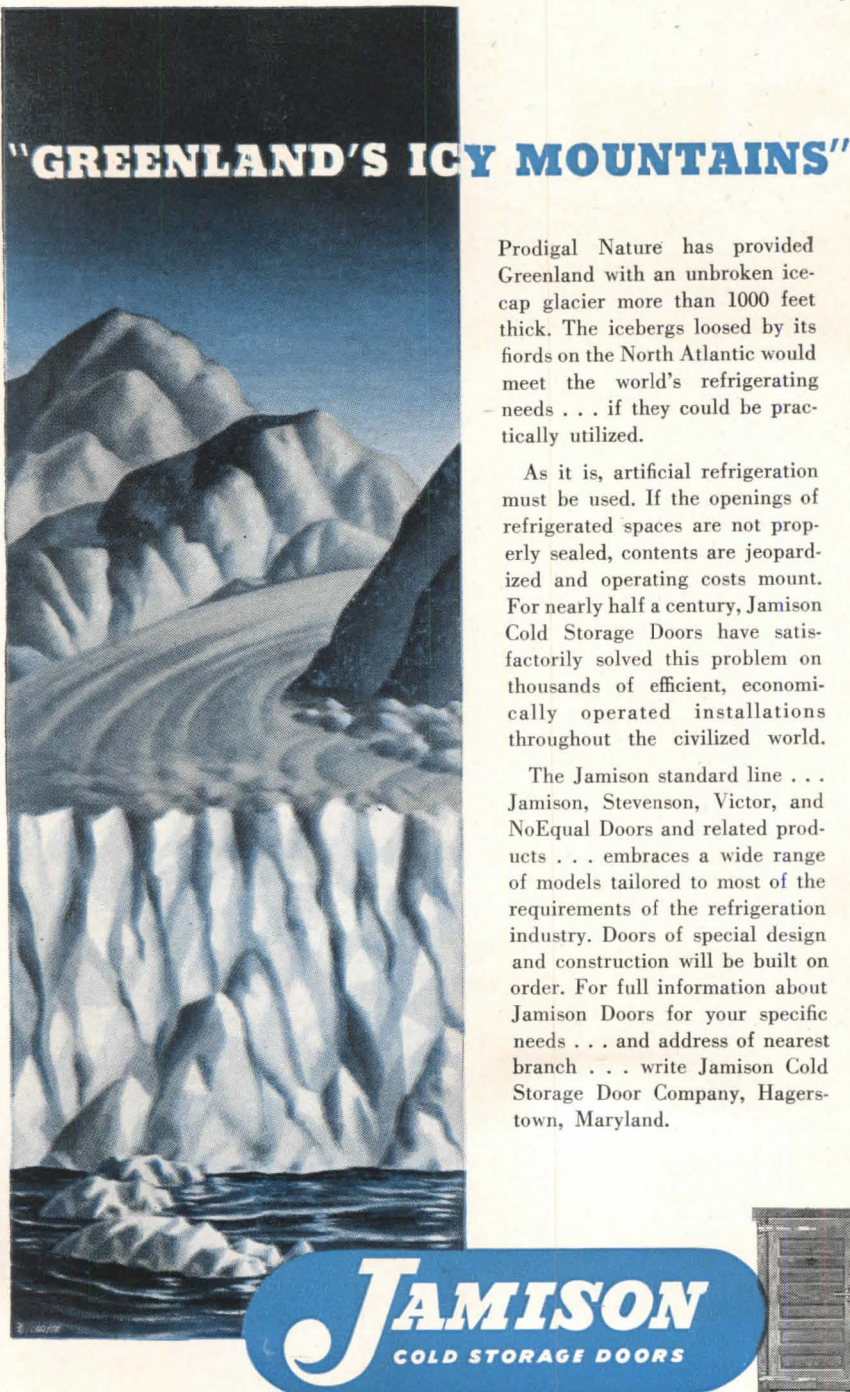

**"GREENLAND'S ICY MOUNTAINS"**

Prodigal Nature has provided Greenland with an unbroken ice-cap glacier more than 1000 feet thick. The icebergs loosed by its fiords on the North Atlantic would meet the world's refrigerating needs . . . if they could be practically utilized.

As it is, artificial refrigeration must be used. If the openings of refrigerated spaces are not properly sealed, contents are jeopardized and operating costs mount. For nearly half a century, Jamison Cold Storage Doors have satisfactorily solved this problem on thousands of efficient, economically operated installations throughout the civilized world.

The Jamison standard line . . . Jamison, Stevenson, Victor, and NoEqual Doors and related products . . . embraces a wide range of models tailored to most of the requirements of the refrigeration industry. Doors of special design and construction will be built on order. For full information about Jamison Doors for your specific needs . . . and address of nearest branch . . . write Jamison Cold Storage Door Company, Hagerstown, Maryland.

**JAMISON**  
COLD STORAGE DOORS



Branches in Principal Cities, Coast to Coast



# Get **BETTER WORKMANSHIP** with **BRIXMENT!**

No. 4 OF A SERIES—

## THE RIGHT WAY AND THE WRONG WAY—IN HEADER COURSES



Mortar should be spread over the entire side of the header brick before it is placed on the wall.



*To secure full header joints, mortar should be spread over the entire side of the header brick before it is placed in the wall.*

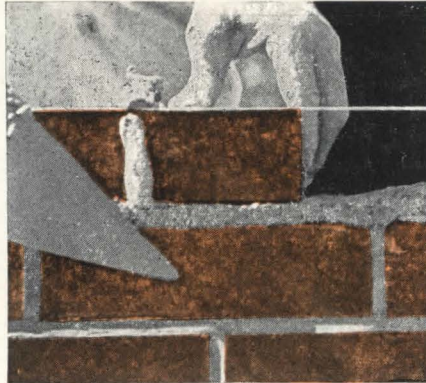

The brick should be shoved into place so mortar oozes out at the top of the joint.



This completely fills the joint.

## **BRIXMENT**

is so workable, so plastic, that when the bricklayer pushes the brick into place, he does not have to *force* it home. The excess mortar "flows" readily into every part of the joint, thus providing good, full joints without requiring extra work or effort on the part of the bricklayer.

Aside from its greater plasticity, Brixment mortar has higher water-retaining capacity and bonding quality, greater resistance to freezing and thawing, and freedom from efflorescence. Because of this combination of advantages, Brixment is the leading masonry cement on the market.



When a dab of mortar is spotted on one corner of the brick,



*A dab of mortar spotted on one corner (or both corners) of the brick cannot possibly fill the cross joint. Slushing will not fill the voids.*



there is very little mortar in the cross joint.

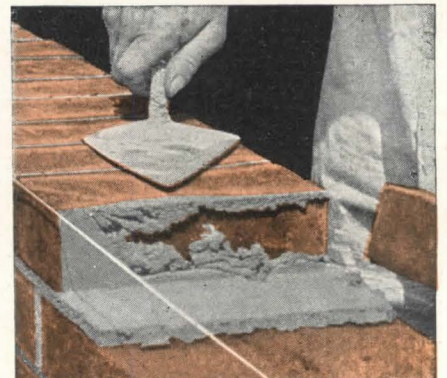

Slushing will not fill the voids.

**LOUISVILLE CEMENT CO.**  
*Incorporated*  
**LOUISVILLE, KY.**



(Continued from page 122)

pillow during the day. Seat of the sofa bed is covered with a tailored slipcover, which the hotel guest removes to uncover the made-up bed. Model hotel rooms, decorated by James McCutcheon & Co., have been designed for the Roosevelt in New York City; Williamsburg Inn, Williamsburg, Va.; the Radison, Minneapolis; the Utah, Salt Lake City; the Olympic, Seattle; and the St. Francis, San Francisco. James McCutcheon & Co., 609 Fifth Ave., New York, N. Y.

## STORAGEWALL

*Storage* wall units are now obtainable, after being in the design stage for several years, and are on display in a few department stores throughout the country, such as Macy's in New York. These prefabricated wood cabinet units, originally designed by George Nelson and Henry Wright, permit great freedom in the arrangement of storage space, either along the wall or as a free-standing division between rooms. Every foot of such



Larry Gordon Photo

Prefabricated wall units serve for storage

## STEEL JOISTS AND STUDS YOU CAN NAIL INTO LIKE WOOD

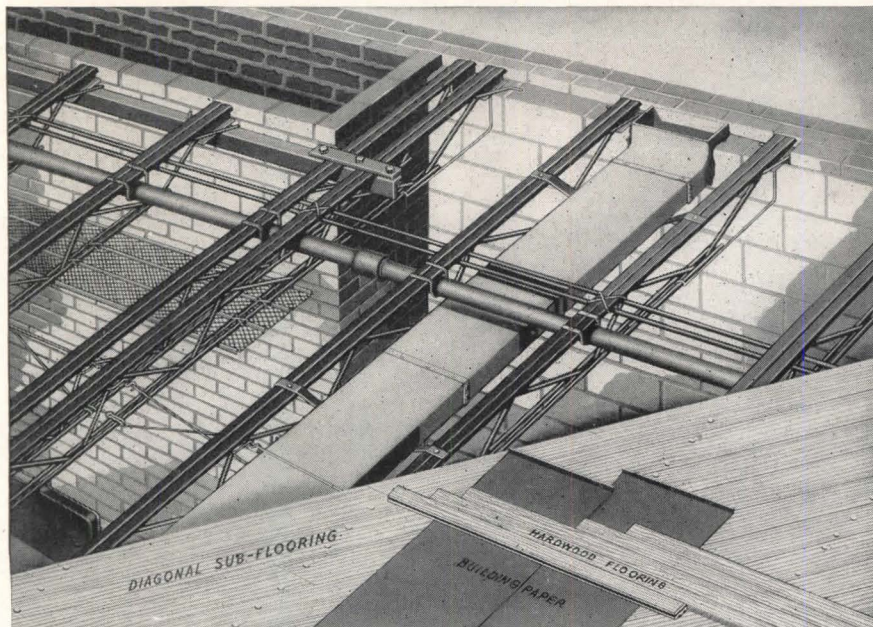

PATENTS PENDING

Builders everywhere have welcomed these improved steel sections. Adding NAILABILITY to the original Macomber Bar Joist now gives designers and builders one steel joist of universal application.

Shown above is the Macomber V-Type Bar Joist in a typical dwelling installation. Flooring is nailed directly to joists. More room is provided for pipe and duct work. Sizes are determined from standard Steel Joist Institute Loading Table. Made in Joist, Purlin and Stud sections.

Further information upon request. See our catalog in Sweet's 1947.



# MACOMBER

CANTON • OHIO

MEMBER OF THE STEEL JOIST INSTITUTE

a wall may serve for storage: the lower sections in various combinations of bookcases, wardrobes, china closets, radio-phonograph cabinets, linen closets, chests of drawers, dressers, and desks; and upper sections for long-term storage. The units measure 12 in., 18 in., and 24 in. deep, and vary as to height and width to fit various room lengths and ceiling heights. They are lacquered in five colors — gray, pale blue, chartreuse, deep green, and black — or available in natural wood finish. Storage wall, Inc., Box 254, Indian Orchard, Springfield, Mass.

## HEAVY-DUTY ELEVATORS

A new line of industrial elevators has been designed for buildings where trucking imposes unusually severe loading. Today, most industrial trucks are of the pallet-loading type, short-coupled, and with narrow wheelbases, and impose a tremendous amount of twisting and tilting of the elevator car. Often the load is concentrated on less than one fourth of the elevator floor space. The new elevators are of heavier construction and specially engineered for this new type of service. Otis Elevator Co., 260 Eleventh Ave., New York 1, N. Y.

## ADJUSTABLE FLOOR DRAIN

The *Leveze* floor drain has an adjustable top that can be raised or lowered to compensate for variations in floor level. It is installed with the adjustable top in "neutral" position, which permits the top and grate to be raised or lowered to the proper level when floor construction is set. This feature also is said to expedite repairs to floors without disturbing drain body, drainage lines, or arch. When a new floor finish of considerable height is added, an extension collar can be used. Josam Mfg. Co., Ferguson Bldg., Cleveland, Ohio.

## ASPHALT SHINGLES

Marketed under the name of *Duble-Coverage Tite-On* is a new line of asphalt shingles that interlock and overlap so as to provide two thicknesses of shingles over entire roof area. This design is said

(Continued on page 138)



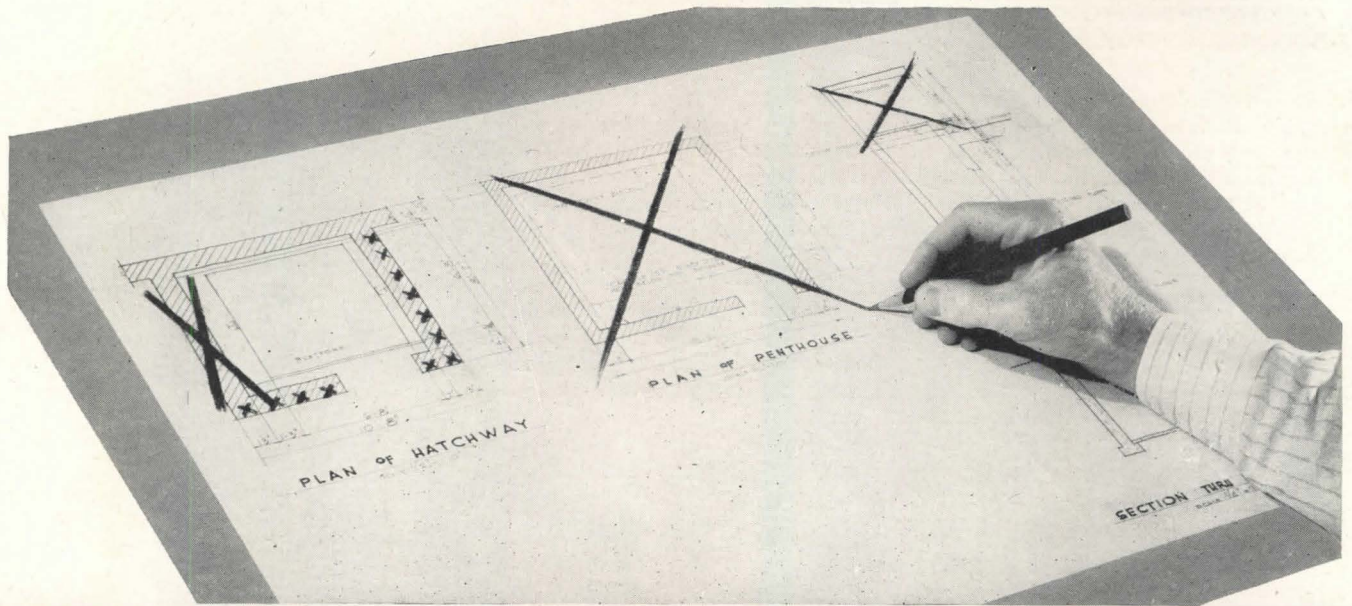

**You can "X out" the penthouse  
and heavy sidewalls !**

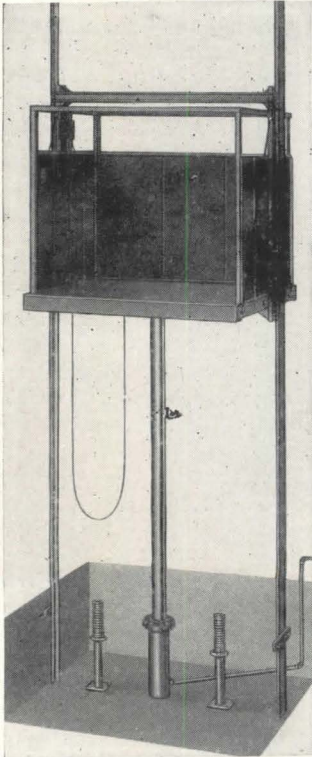

**Elevator That's Pushed Up  
Cuts Construction Costs  
and Streamlines Designs**

Yes, you can take your pencil and cross off the penthouse and heavy hatchway sidewalls on the plans for that new building . . . by specifying Oilhydraulic Elevators.

**It's Done by Hydraulic Power**

This modern elevator reduces load lifting to simple fundamentals. Loads are **pushed up** from the ground hydraulically instead of pulled from above by mechanism which requires the building structure to support the entire weight of the elevator and contents. This eliminates the unsightly penthouse and heavy load-bearing sidewalls. The compact power unit can be located

in any convenient space on any landing. Result: lowered construction costs and streamlined building designs.

**Accurate Landing Stops**

The Oilhydraulic Elevator is raised by an oil-hydraulic jack, electrically powered. Operation is hydraulically smooth . . . no abrupt starts or stops. Landing stops are very accurate, which is extremely important where power vehicles are to be used in loading and unloading.

**For 2, 3 or 4-Stories**

Operating cost is low . . . power used only on rise, descent by gravity. Maintenance expense is low, too. Thousands of architects, engineers and owners say that Oilhydraulic Elevators are the most practical and economical type for rises up to 40 ft.

**Send for data  
to help solve  
elevator problems →**



**ROTARY LIFT CO.**  
1004 Kentucky, Memphis 2, Tenn.

Send Catalog RE-301 (AIA File 33) to:

Name.....

Address.....

City and State.....

**Rotary OILDRAULIC ELEVATORS**

ROTARY ALSO MAKES OILDRAULIC LEVELATORS • LUMBER LIFTS • AUTO AND TRUCK LIFTS



# ARCHITECTURAL ENGINEERING

TECHNICAL NEWS AND RESEARCH

(Continued from page 136)

to give increased resistance to rain and wind. The shingles are designed for new roof construction, but can also be applied over old roofs. They carry the Class C label of the National Board of Fire Underwriters. The Rubberoid Co., 500 Fifth Ave., New York 18, N. Y.

## ROOF VENTILATOR

*Ject-O-Valve* powered ventilator is a "straight-through" type for roof installation in industrial buildings. A propeller

fan exhausts heat, smoke, and fumes through a divided top which opens and closes automatically. The ventilator is manufactured in five sizes with a wide range of capacities. The Swartwout Co., Cleveland, Ohio.

## SELF-COOLED FOUNTAIN

A new wall-type drinking fountain has its own *Temprite* water cooler built into the porcelain fixture. In multiple installations, individual fountains can be



Wall-type fountain has built-in cooler

placed where desired and all operated from a conveniently located condensing unit. Individual cooling eliminates the need for heavily insulated water circulating lines, pump, and motor. Tal-Co Mfg. Co., 510 N. Dearborn St., Chicago.

## WATERPROOFING MEMBRANE

*Glasfab* waterproofing membrane is an evenly woven mesh made wholly of inorganic glass fibers. These fibers are said to withstand temperatures up to 1000°; are not charred or burned by hot bitumen; and being unaffected by moisture, will not rot or decay. The mesh is designed to be light and flexible so that it will mold itself readily to uneven roof surfaces. The Lexington Supply Co., 4815 Lexington Ave., Cleveland 3, Ohio.

## CONDENSATION PROTECTION

*Industrial NoDrip* is a plastic cork coating that reportedly will keep moisture from forming on metal, concrete, brick, wood, plaster, or composition surfaces when condensation is due to temperature differential. It is supplied in a plaster-like form and applied in thick coats with a trowel, putty knife, brush, spray, or by hand. Aside from combatting moisture, the coating is said to offer advantages of acting as a moisture-proof insulation and protecting metals against corrosion. NoDrip is black but can be painted. One gallon will cover about 6 sq. ft. of surface with a coating  $\frac{1}{4}$  in. thick. J. W. Mortell Co., Kankakee, Ill.

## WIRED BASEBOARD

The *Wire-Hiway Base* is an aluminum baseboard designed to provide wiring facilities and to anchor partitions. Outlets can be provided wherever and whenever needed. The base is  $3\frac{1}{2}$  in. high, coved at top and bottom. Front panel is removable to make wiring accessible. A foot-operated switch eliminates need for a wall switch. Other models with dual "hiways" are available for industrial plants and office buildings. Charles E. Barnes & Son, 4320-22 Osage Ave., Philadelphia 4, Penn.

(Continued on page 140)

# The Public Be Pleased!

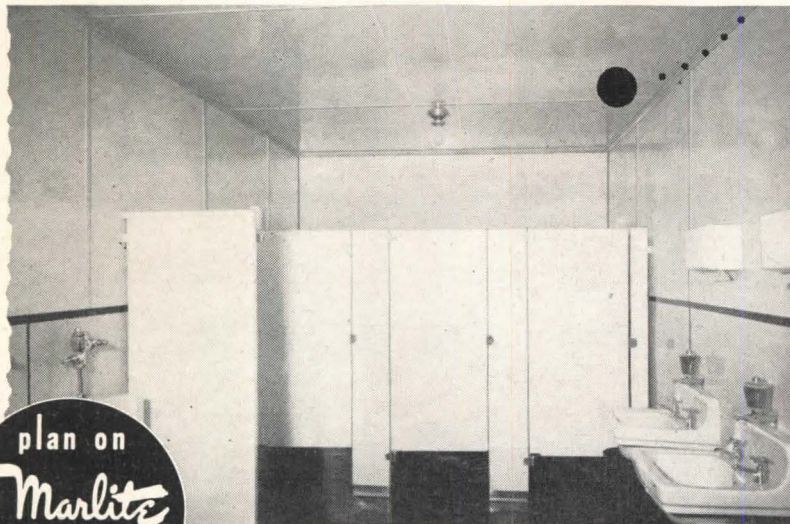

plan on  
**Marlite**  
walls



**Y**ou can design sanitation and cleanliness right into hotel and restaurant rest rooms with plastic-finished Marlite wall and ceiling panels. Plan on Marlite's sparkling clean beauty to complement any architectural treatment . . . and plan, too, on Marlite's economy - it's easy to install and easy to keep clean. Adaptable to new construction or modernization, versatile Marlite is at once attractive and practical. Although production of Marlite is greater than ever before, the tremendous demand makes it necessary to continue allocation of orders for the present. Marsh Wall Products, Inc., 805 Main Street, Dover, Ohio.

FOR CREATING  
BEAUTIFUL  
INTERIORS





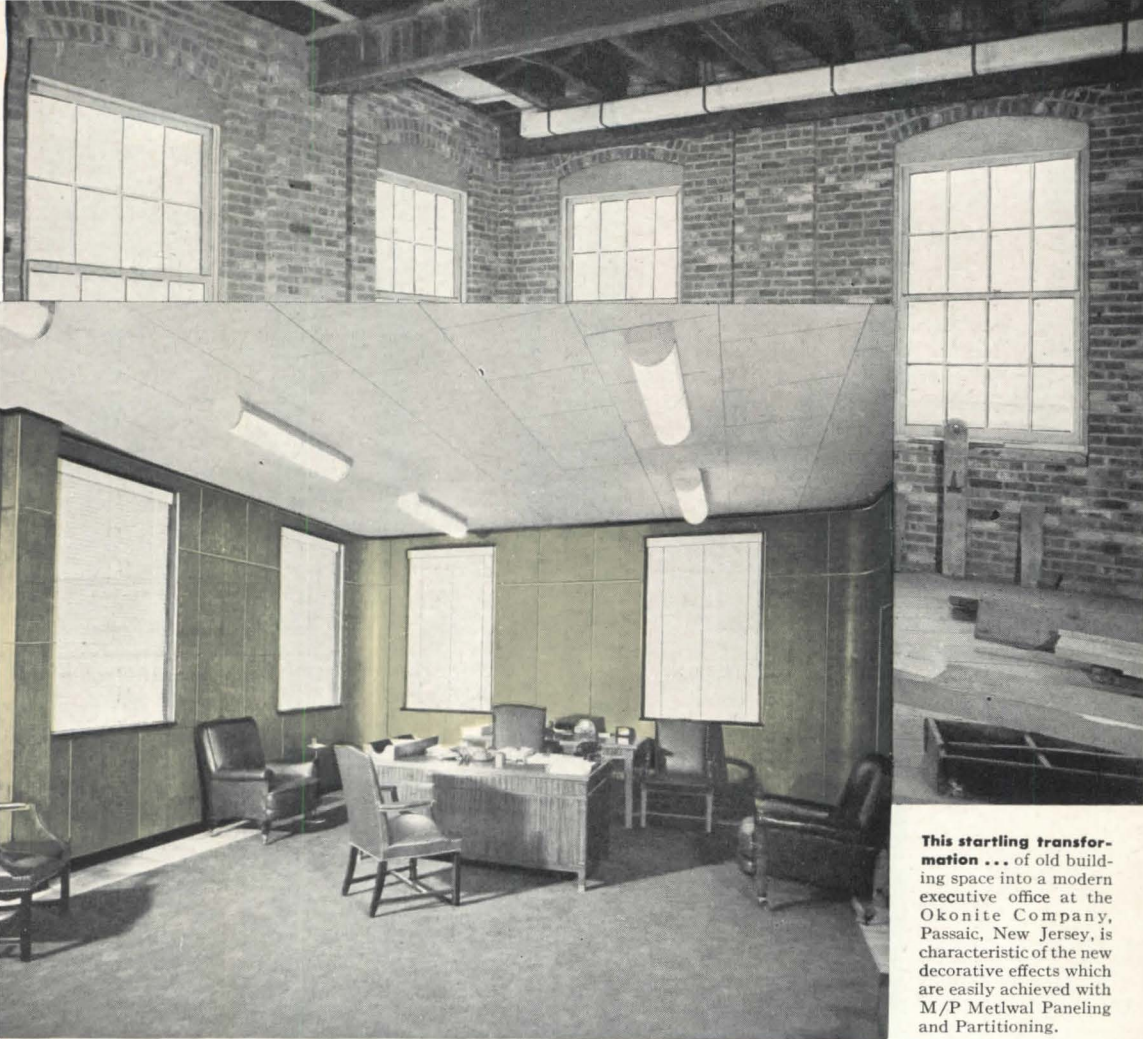

**This startling transformation . . . of old building space into a modern executive office at the Okonite Company, Passaic, New Jersey, is characteristic of the new decorative effects which are easily achieved with M/P Metlwal Paneling and Partitioning.**

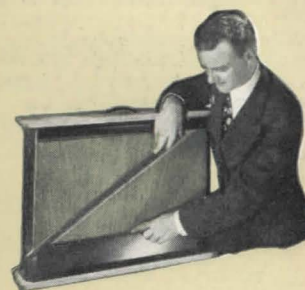

**See this 10-minute demonstration.** Learn how this modern method of paneling and partitioning fits your building, modernizing or partitioning plans. **CALL YOUR NEAREST M/P DISTRIBUTOR TODAY.**

**YOUR M/P DISTRIBUTOR**

- ALABAMA
- Birmingham . . . Acousti Engineering Co.
- Mobile . . . Acoustics & Specialties Co.
- ARKANSAS
- Little Rock . . . Acoustics & Specialties Co.
- CALIFORNIA
- Los Angeles . . . The Harold E. Shugart Co.
- Oakland . . . F. K. Pinney, Inc.
- Sacramento . . . F. K. Pinney, Inc.
- San Francisco . . . F. K. Pinney, Inc.
- COLORADO
- Denver . . . Lauren Burt, Inc.
- CONNECTICUT
- Hartford . . . The C. A. Bader Co.
- DELAWARE
- Wilmington . . . John H. Hampshire, Inc.
- Wilmington (Eastern Shore) . . . The W. M. Moyer Co.
- DISTRICT OF COLUMBIA
- Washington . . . John H. Hampshire, Inc.
- FLORIDA
- Jacksonville . . . Acousti Engineering Co.
- Miami . . . of Fla.
- Pensacola . . . Acoustics & Specialties Co.
- GEORGIA
- Atlanta . . . Acousti Engineering Co.
- ILLINOIS
- Decatur . . . Hugh J. Baker & Co.
- INDIANA
- Evansville . . . Hugh J. Baker & Co.
- Ft. Wayne . . . Hugh J. Baker & Co.
- Indianapolis . . . Hugh J. Baker & Co.
- Wabash . . . Hugh J. Baker & Co.
- KENTUCKY
- Louisville . . . E. C. Decker & Co.
- LOUISIANA
- New Orleans . . . Acoustics & Specialties Co.
- MAINE
- Portland . . . Pitcher & Co.
- MARYLAND
- Baltimore . . . John H. Hampshire, Inc.
- MASSACHUSETTS
- Boston . . . Pitcher & Co.
- Springfield . . . The C. A. Bader Co., Inc.
- MICHIGAN
- Detroit . . . E. E. Legnette Co.
- Grand Rapids . . . Leggette-Michaels Co.
- MINNESOTA
- Minneapolis . . . Insulation Sales Co., Inc.
- MISSOURI
- Kansas City . . . Henges Co., Inc.
- St. Louis . . . Henges Co., Inc.
- NEW JERSEY
- Elizabeth . . . Jacobson & Co.
- Trenton . . . The W. M. Moyer Co.
- NEW MEXICO
- Albuquerque . . . The Jay Gear Corp.
- NEW YORK
- Albany . . . Collum Acoustical Co.
- Buffalo . . . Collum Acoustical Co.
- Jamestown . . . Collum Acoustical Co.
- Rochester . . . Collum Acoustical Co.
- Syracuse . . . Collum Acoustical Co.
- New York City . . . Jacobson & Co.
- NORTH CAROLINA
- Charlotte . . . Acousti Engineering Co. of the Carolinas
- OHIO
- Akron . . . Mid-West Acoustical & Supply Co.
- Cleveland . . . Mid-West Acoustical & Supply Co.
- Columbus . . . Mid-West Acoustical & Supply Co.
- Toledo . . . Mid-West Acoustical & Supply Co.
- Cincinnati . . . E. C. Decker & Co.
- Dayton . . . E. C. Decker & Co.
- PENNSYLVANIA
- Altoona . . . Harry C. Leezer Co.
- Pittsburgh . . . Harry C. Leezer Co.
- Sharon . . . Harry C. Leezer Co.
- Harrisburg . . . The W. M. Moyer Co.
- Philadelphia . . . The W. M. Moyer Co.
- Scranton . . . The W. M. Moyer Co.
- RHODE ISLAND
- Providence . . . Pitcher & Co.
- SOUTH CAROLINA
- Charleston . . . Acoustic Engineering Co. of the Carolinas
- SOUTH DAKOTA
- Sioux Falls . . . Insulation Sales Co., Inc.
- TENNESSEE
- Chattanooga . . . Len Herndon Co.
- Knoxville . . . Len Herndon Co.
- Nashville . . . Len Herndon Co.
- Memphis . . . Acoustics & Specialties Co.
- TEXAS
- Dallas . . . S. W. Nichols Co.
- Houston . . . S. W. Nichols Co.
- San Antonio . . . S. W. Nichols Co.
- El Paso . . . The Jay Gear Corp.
- UTAH
- Salt Lake City . . . Lauren Burt, Inc.
- VIRGINIA
- Norfolk . . . John H. Hampshire, Inc.
- Richmond . . . John H. Hampshire, Inc.
- Roanoke . . . John H. Hampshire, Inc.
- WEST VIRGINIA
- Huntington . . . E. C. Decker & Co.
- Clarksburg . . . E. C. Decker & Co.
- Wheeling . . . Harry C. Leezer Co.
- WISCONSIN
- Milwaukee . . . Edw. T. VerHalen, Inc.
- WYOMING
- Cheyenne . . . Lauren Burt Inc.

**Looking for a FASTER, EASIER way to get Distinctive, Permanent Paneling?**

ORDINARY buildings and rooms are quickly transformed into smart, distinctive offices by Martin-Parry Metlwals. Using only a few standard parts from warehouse stock, M/P Metlwals permit fast, easy installation of permanent paneling . . . eliminate the need for any type of filler board, plaster, or other construction materials. And Metlwal is ideal for new construction, too.

**Movable Partitions for Flexible Floor Plans**

In outer offices, where efficient use of space may require floor plan changes, Metlwal movable partitions provide a durable, attractive means of dividing space . . . permanent, yet easily moved without waste of time or material.

tory finished in natural woodgrain reproductions or in a variety of baked enamel colors. These beautiful finishes will not crack, chip or craze . . . do not reflect harsh metallic light. Bonderized against rust and corrosion, Martin-Parry Metlwals meet every paneling and partitioning requirement and assure faster, cleaner, easier installation . . . combine long life, lasting beauty, soundproofing and fire resistance with low initial cost and easy maintenance.

Write today for FREE BOOKLET A8 for your A.I.A. file . . . showing how Metlwals can help you plan and utilize office space more effectively . . . how Metlwals are made and installed . . . along with specifications and photos of actual installations. ADDRESS: Martin-Parry Corporation, Fisher Building, Detroit 2, Michigan. PLANTS: Toledo, Ohio; York, Pa.



**Factory Finished in Crackproof, Chipproof Enamel**  
The face sheets of M/P Metlwals are fac-

**MARTIN PARRY**  
**MP**  
**RODUCTS**

**METLWALS**

**ALL-FLUSH PANELING**  
**MOVABLE PARTITIONS**

**67 Years of Service**

**ENGINEERING AND ERECTING SERVICE AND**  
**WAREHOUSE STOCKS FROM COAST-TO-COAST**



(Continued from page 138)

## WALL COVERING

Varlar has been announced as a virtually stainproof wall covering, manufactured by a thermoplastic process employing resins with stainproof, greaseproof, and mildewproof characteristics. According to test reports, practically every type of stain is removed quickly by soap and water; the few exceptions requiring a light wiping with turpentine. Varlar, Inc., Div. of United Wallpaper, Inc., Merchandise Mart, Chicago 54, Ill.

## METAL PARTITIONS

The *Metlwal* system of partitioning and paneling features the use of a few standardized parts for simplified installation in industrial and commercial buildings. The basic unit is an asbestos-lined sheet steel panel with corrugated steel backing. Panels are snapped onto steel studs set in floor and ceiling channels, and provide an all-flush surface from floor to ceiling. A partition consists of two panels, 3½ in. apart, leaving space be-

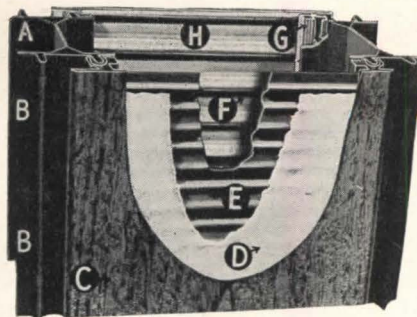

Cutaway section of *Metlwal*: (A) steel studs for partition, (B) snap-on indent, (C) steel panel face, (D) asbestos lining, (E) and (F) corrugated steel backing, (G) panel stiffener, and (H) 3½-in. air space

The Engineer Sees It Through...at

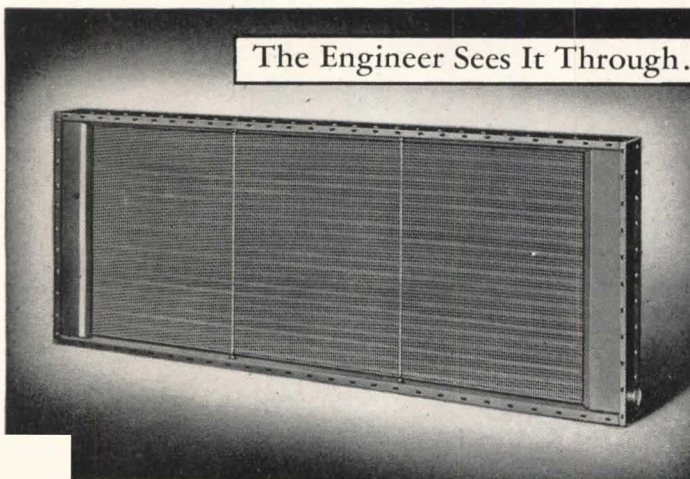

## Coils . . . Designed for Every Requirement

The complete line of usAIRco coils includes steam coils for heating, standard and non-freeze type, water coils for heating and cooling and direct expansion coils. These coils are properly designed, skillfully manufactured, and expertly engineered to the job requirement.

The usAIRco engineer follows through from design board through the installation. He specifies that coils are constructed for heavy service and dependability—he sees that you get a mechanically efficient tool. And most important, the usAIRco engineer helps you put the coil to work on your specific job.

Get acquainted with helpful usAIRco engineers on your next air conditioning job.

UNITED STATES AIR CONDITIONING CORP.  
Minneapolis 14, Minnesota

Factory Representatives in Principal Cities



Plus

Cooperative  
Engineering Counsel

Available to your air conditioning, heating or ventilating problems is the advice and counsel of the engineering staff of usAIRco. With a background of nearly twenty-five years, it is one of the most experienced in the industry. We invite you to use it freely and fully.

TESTED . . . AND PROVED

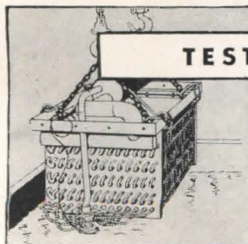

Every coil takes a final plunge before going off to work for you. High pressure is applied to show up weak spots in construction. This test, and others, assure dependable performance on the job.

tween for pipes and cables. The studs are slotted to receive wiring. Since panels correspond to door sections, doors may be located where desired. The exterior face of the panels is factory-finished in either woodgrain or baked enamel finish. Interchangeable units include standard sections for ceiling and cornice-high partitions, movable steel railings, and such accessories as sliding windows, information windows, vertical or horizontal pivoted sashes, slotted metal bases for air circulation, and standard glass or solid panel doors with louvers and transom. Martin-Parry Corp., Fisher Bldg., Detroit 2, Mich.

## HOT-AIR HEATING

The R9 oil burning furnace is designed for location on the same floor level as the rooms to be heated. In this packaged central heating unit, warm air is forced from the bottom of the furnace and return air enters at the top and is forced down over the surface of the combustion drum by a large circulating air blower. Insulated ducts can be run beneath the floor to various rooms, or the warm air can be conducted in clay sewer pipe imbedded in the concrete floor around the perimeter of the house, for additional panel heating effect. Sheet metal work is simplified by the provision of knock-out blanks at sides, front, back, and underneath the furnace. The furnace is equipped with operating controls and a humidifier. International Oil Burner Co., St. Louis 10, Mo.

## FOR CLEANER DRAWINGS

*Draw-Kleen* removes smudges, fingerprints, and dust from drawings and blueprints. It comes in the form of fine soft "crumbles" that are sprinkled on the surface and rubbed with the palm of the hand. It can also be used on drawings to gray down pencil lines in preparation for the final rendering. *Draw-Kleen* is packaged in a 1½-oz. shaker-top can. The Craftint Mfg. Co., Cleveland, Ohio.  
(Continued on page 142)



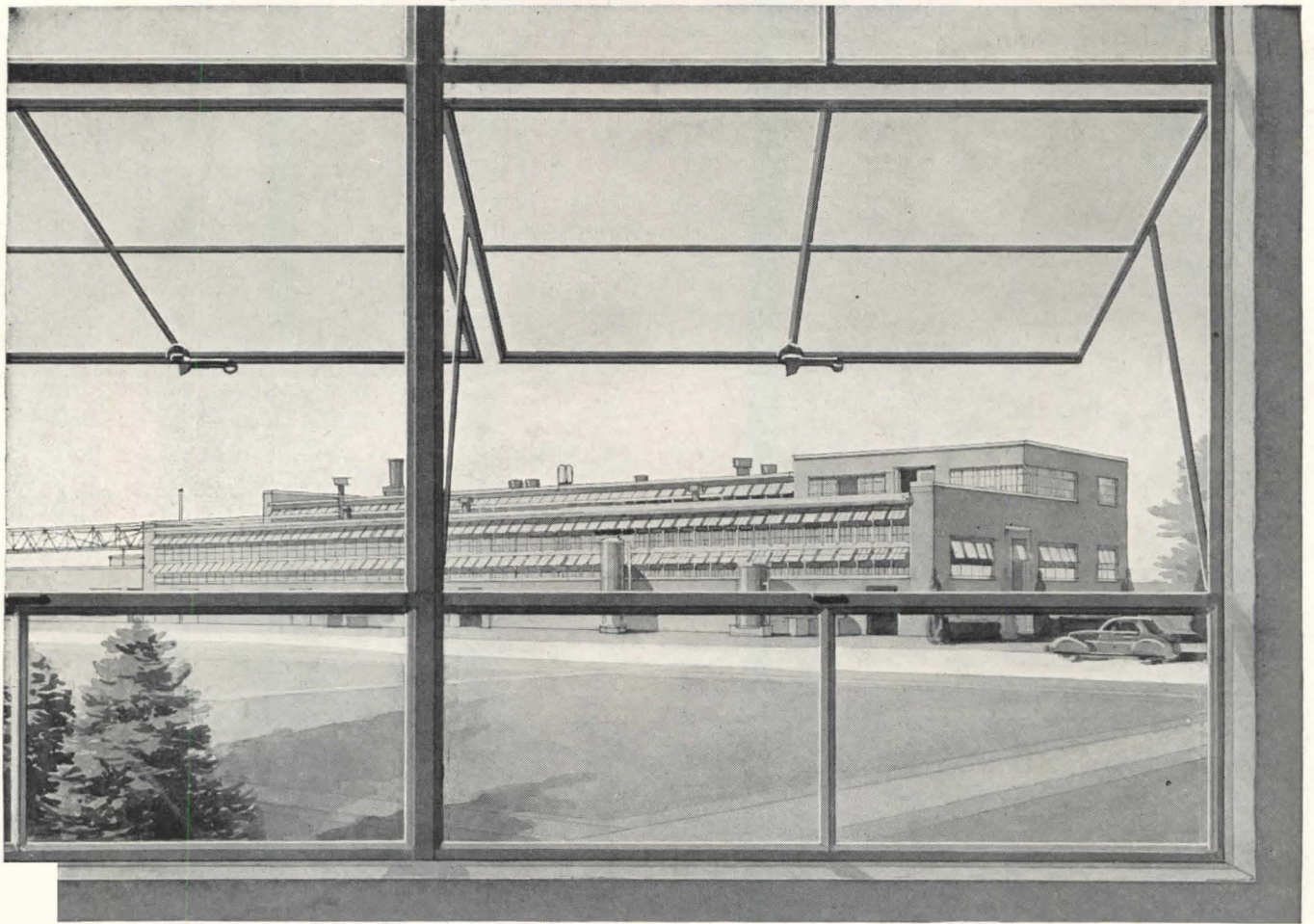

Recent Lupton Metal Window installation at the research and development laboratories of the Socony Vacuum Oil Company at Paulsboro, N. J. Architect: Frederick G. Frost, N. Y. Contractor: Skinner, Cook and Babcock, N. Y.

Daylighting requirements vary widely from one factory-type building to the next—refinery, manufacturing plant, warehouse or power plant. That is why the Lupton experience in industrial window applications is so important. There are three basic types of Lupton Windows for industrial buildings—continuous windows, pivoted windows and projected windows—each offering positive assurance of improved working conditions and increased working efficiency through abundant daylighting and controlled ventilation. Write for the 1947 Catalog or see our Catalog in Sweet's.

MICHAEL FLYNN MANUFACTURING CO.  
700 East Godfrey Avenue Philadelphia 24, Penna.

# L U P T O N

## M E T A L W I N D O W S



(Continued from page 140)



**"WHERE A FAN BELONGS"**

*Blo-Fan* electric ceiling ventilator builds in between the ceiling joists directly over the kitchen range—where a fan belongs.

*Blo-Fan* ducts out smoke, odors and grease-laden air... as they rise... before they spread.



*Blo-Fan* patented blade provides the volume of a propeller with the power of a blower.

*Blo-Fan* is nationally distributed by General Electric Supply Corp. and more than 300 other distributors. Consult Sweet's Catalog, AIA File 30-D-1, or write for complete information.

**Blo-Fan**

ELECTRIC CEILING VENTILATION

MORE THAN A FAN  
MORE THAN A BLOWER

PRYNE & CO., INC.

LOS ANGELES 54, CALIFORNIA  
NEW YORK CHICAGO

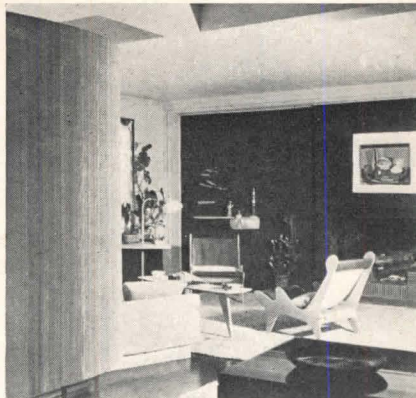

Screen wall is of textured plywood, on open frames, natural pine finish (house of Alexander H. Girard, Architect)

**PLYWOOD PANELING**

*Weldtex*, the plywood panel designed by Donald Deskey, has striations cut into the outer layer of plywood veneer, giving an unusual finish of parallel, random-width lines. It is said to be moisture-resistant for interior installations, and waterproof for exterior use. Textured effects can be varied by alternating the direction of the striations, and the board can be applied to either flat or curved surfaces. U. S. Plywood Corp., 55 W. 44th St., New York 18.

**RUBBER TILE**

*Amtico rubber tile flooring* is now available in 13 marbelized colors; announced as particularly suitable for areas where traffic is heavy, and flooring must be long-wearing, easy to clean, and resistant to cigarette burns. American Tile Co., Trenton, N. J.

**ANGLE INDICATOR**

A carpenter's level and angle indicator has been announced under the name of *Anglevel*. In addition to the usual vials for determining horizontal and vertical levels, there is a dial indicator that determines angles, slopes, and pitches, calibrated in degrees. The frame is of aluminum, weighing only 1 lb. 8 oz. R-D Company, Box 912, Flint, Mich.

**WOOD WINDOW UNITS**

*R-O-W removable window units* have a narrow frame and mullions to increase glass area to a maximum. The sash rides in spring-cushioned non-corrosive metal tracks, which eliminate the need for weights, cords, and pulleys. Both sash can be removed readily for cleaning or painting; or for increased ventilation of sun porches in hot weather. R-O-W Sales Co., Royal Oak, Mich.

(Continued on page 144)



**MARCELLUS CENTRAL HIGH**

MARCELLUS, N. Y.

Carl W. Clark, A.I.A.

*Leading Architects*

SPECIFY

**HILLYARD  
Products, because**

Hillyard's Floor Seals, Finishes and Treatments properly protect and prolong the life of all types of floors. Floors stay cleaner, look better and last longer. Many leading flooring manufacturers and contractors approve Hillyard Products because they have given and are giving entire satisfaction in uniformity, dependability and economy. Write for literature on Hillyard products for every type surface.



**HILLYARD SPECIFICATION CARDS**

See Hillyard Specifications in Sweet's 1946 Catalog, Sec. 13, Pages 13G-2



Send for Specification Cards. FREE for the asking.

**HILLYARD SALES CO.'S**

DISTRIBUTORS  
**HILLYARD CHEMICAL CO. ST. JOSEPH, MO.**  
370 TULIP ST. SAN FRANCISCO 2, CALIF. 1947 BROADWAY, NEW YORK 23, N. Y.



MADE FROM THE LONG FIBERS OF MATCHLESS DOUGLAS FIR

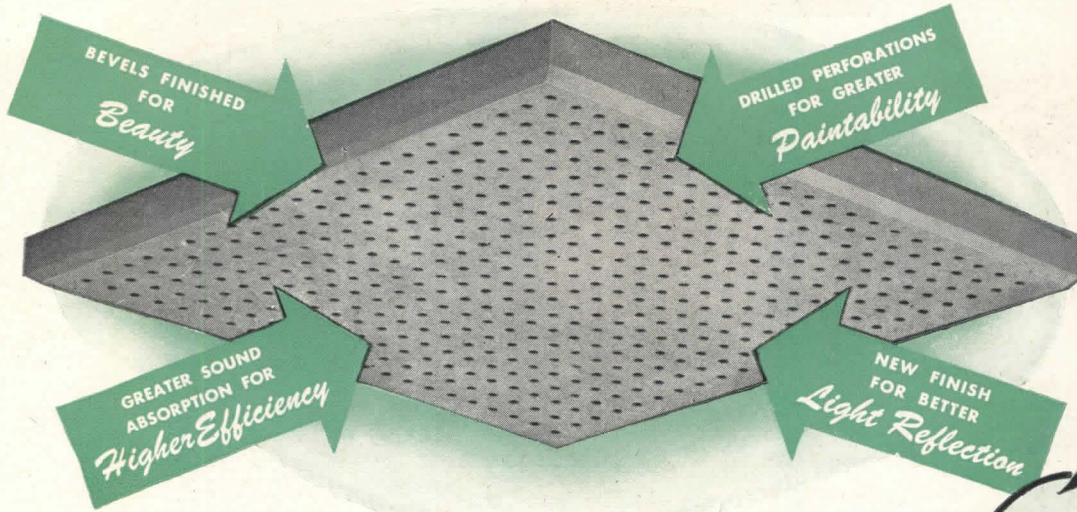

## NO OTHER PERFORATED ACOUSTICAL TILE GIVES ALL THESE ADVANTAGES for Noise-Quieting and Acoustical Correction

AS the result of more than half a century of experience in the wood products field, Simpson "know-how" has developed a new acoustical tile having the advantages long sought by architects and builders. Taking full advantage of the long and tough Douglas fir fiber, Simpson developed a new manufacturing process and new automatic controls guaranteeing uniformly high quality. Result is an improved post-war product . . . an acoustical tile of unparalleled quality . . . of higher sound absorption and designed to give greater ceiling beauty. By an improved process, the 484 perforations per tile unit are *drilled*. Because of the clean drilled perforations, the tile can be painted repeatedly without losing acoustical efficiency. Bevels are finished in the same attractive oyster-white as the tile surface, giving added beauty. Architects will find that noise-quieting and acoustical problems are solved easier with Simpson Acoustical Tile, and installations are much more attractive.

**Simpson**  
QUALITY SINCE 1895



# ACOUSTICAL TILE

WOODFIBER DIVISION • SIMPSON LOGGING COMPANY

Plant at Shelton, Washington • Sales Division, 1010 White Building, Seattle 1, Washington

Also manufacturers of LUMBER • PLYWOOD • DOORS

DISCUSS THIS NEW  
ACOUSTICAL TILE WITH  
YOUR NEAREST SIMPSON  
APPLICATOR

ALLIED CONSTRUCTION &  
SPECIALTY CO., INC.  
8455 Melrose Ave.  
Los Angeles 46, Calif.  
Phone: Walnut 0541

ANGELES INDUSTRIES  
984 McGarry St.  
Los Angeles, Calif.  
Phone: Vandike 1783

ARIZONA SASH, DOOR & GLASS CO.  
657 West St. Mary's Road  
Tucson, Ariz.  
Phone: 1699

CONSOLIDATED ROOFING & SUPPLY  
COMPANY  
520 South 7th Ave.  
Phoenix, Ariz.  
Phone: 47888

CONTINENTAL LUMBER CO.  
P. O. Box 2042  
Boise, Idaho  
Phone: 450

ELLIOTT BAY LUMBER CO.  
600 W. Spokane St.  
Seattle, Wash.  
Phone: Elliott 8080

ELLIOTT BAY LUMBER CO.  
2712 McDougall St.  
Everett, Wash.  
Phone: Main 150

EXCHANGE LUMBER & MFG. CO.  
P. O. Box 1514  
Spokane 7, Wash.  
Phone: Glenwood 1621

FROST HARDWOOD LUMBER CO.  
327-29 W. Market St.  
San Diego, Calif.  
Phone: F-7224

LUMBER DEALERS, INC.  
1301 Wazee St.  
Denver 17, Colo.  
Phone: Tabor 6141

LUMBER DEALERS, INC.  
108 South Main St.  
Pueblo, Colo.  
Phone: 4881

LUMBER DEALERS, INC.  
423 No. 33rd  
Billings, Mont.  
Phone: 3911

ROSE CITY FLOOR & INSULATING CO.  
Railway Exchange Building  
Portland, Ore.  
Phone: Atwater 6444

UTAH LUMBER CO.  
333 W. 1st So.  
Salt Lake City 9, Utah  
Phone: 4-4318



(Continued from page 142)

**No  
Waiting**  
**WHEN  
YOU  
USE**

**LITH-I-BAR**

**FIRE  
SAFE  
LIGHT  
WEIGHT  
CONCRETE  
JOISTS**

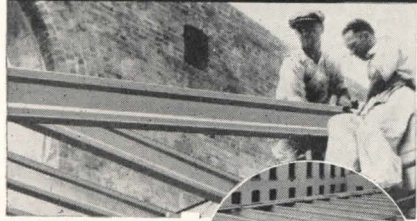

**IMMEDIATELY  
AVAILABLE**

For All Types of Fire-Safe Building. For small homes, apartments, schools, hospitals, or any type of commercial or industrial buildings, the Lith-I-Bar system will provide greater speed, simplicity, minimum in field work, therefore economy.

Lith-I-Bar machine made joist utilizes the exclusive Lith-I-Bar method of electrically welded reinforcing. Wide range of sizes and lengths up to 36 feet.

Wire, write or call today for location of your nearest licensed manufacturer.

**GET THIS  
FREE**

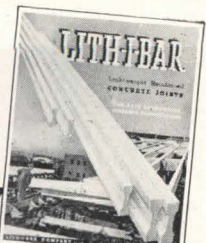

**LITH-I-BAR CO.**  
BOX 8109 HOLLAND, MICH.

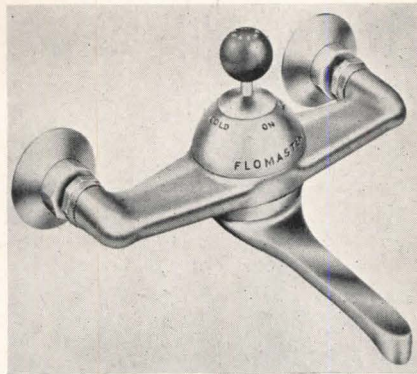

Swivel-type lever on kitchen faucet controls both water volume and temperature

**SINGLE-CONTROL FAUCET**

A new type of faucet for kitchen sinks, known as the *Flow-Master*, has only a single control, operating on the spherical valve principle. Both water temperature and volume are regulated by moving the lever from left to right and back to front. Full left gives cold water only, and right, hot water, with varying mixtures between. Moving the same lever from back to front varies the volume from closed to fully open. Metal parts are chrome-plated brass, and the lever knob is colored plastic. The Lorena Co., Dept. AR, 11917 Vose St., N. Hollywood, Calif.

**STAINLESS STEEL AWNING**

The stainless steel *Lifetime* awning, trimmed in a choice of colors, is announced as particularly suitable for commercial use where appearance counts. Stainless steel construction makes it fire-proof and resistant to acid fumes, salt spray, and severe climatic conditions. Header strip is permanently anchored and caulked to the building. Perma-Steel Corp., 2025 Fenkell Ave., Detroit.

**WORK TABLE**

The *Work-Flow* table is adjustable to enable industrial operators to work at the most comfortable level, whether standing or sitting. Tables are mounted on gliders for easy movement about the plant and adjustable from heights of 26½ in. to 37 in. by means of a hand crank. Standard table top size is 48 in. long by 30 in. wide, and made of tempered Masonite. Body and frame are of heavy-duty plywood, designed to hold a working load of up to 300 lb. Haskell Mfg. Co., 207 Penn Ave., Pittsburgh.

**PAINT BRUSH CLEANER**

*Keepkan* is a packaged unit for cleaning paint brushes before paint hardens; and consists of a solvent in a container

(Continued on page 146)



**How to  
ASSURE  
YOUR CLIENTS  
LASTING FENCE  
PROTECTION**

THE fence you specify gives maximum protection only so long as it maintains correct position. That's why Anchor Chain Link Fence is designed to stand permanently erect and in line. *Deep-Driven Anchors* do this job! They form a three-point, "tree root" anchorage for every post—hold the fence firm in any soil or weather—yet permit easy relocation where necessary.

What's more, when you specify Anchor Fence you get several other features which mean extra years of top-notch service. There are *Square Frame Gates*, free from warping and sagging—*U-Bar Line Posts*, rust-free, rigid and self-draining—*Square Terminal Posts*, which improve strength, durability and appearance.

Send for your free copy of our book, "Anchor Protective Fences," for your A.I.A. File 14-K. It's both a catalog and specification manual. Shows many types and uses of Anchor Chain Link Fence . . . pictures installations for many prominent companies and institutions . . . contains structural diagrams and specification tables. Just ask for Book No. 110. Address: ANCHOR POST FENCE DIV., Anchor Post Products, Inc., 6600 Eastern Ave., Baltimore 24, Maryland.

**Anchor Fence**  
Nation-wide Sales and Erecting Service





## How to Sell Comfort Heating, in Two Easy Lessons

The story of radiant heating is presented colorfully and convincingly in these two new booklets, aimed to help you advise clients on this modern method of home heating . . . and to give home planners *all* the facts about comfort heating.

1. *Enjoy Better Living* is sponsored by The Institute of Boiler and Radiator Manufacturers through a national advertising campaign. Order your copies from the Institute at 60 East 42nd Street, New York City, Dept. SS.

2. *40 Facts About Modern Radiant Heating* is a non-technical, easy-to-read H. B. Smith booklet featuring the outstanding advantages of radiant heating in *all* its forms. It, too, is being advertised nationally. Write to the H. B. Smith Co., Inc. for copies.

\* \* \* \* \*

You can increase client confidence and stimulate their interest in modern home building by giving them copies of these books. Write to the I-B-R and to H. B. Smith for full information on this unique service, *now*.

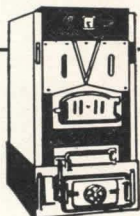
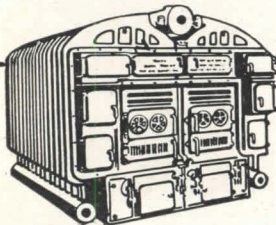

H.B.  
*Smith*  
CAST-IRON BOILERS

THE H. B. SMITH CO., INC., 62 Main Street, Westfield, Mass. Offices and Representatives in Principal Cities



(Continued from page 144)



**Revolving Unit Heaters In-  
sure Complete, Thorough  
Coverage Regardless of  
Obstructions ★ ★ ★**

Not just another unit heater, the WING REVOLVING HEATER is unique in that it does what no other heater can do—its slowly revolving outlets gently distribute the heat continuously in a constantly changing direction. It reaches over, around and under obstructions into out-of-the-way corners, its moving streams of heated air quickly warm up a plant in the morning. Its properly warmed, healthful air currents thoroughly distributed, create a sensation of live, invigorating comfort for the workers. Wing Revolving Unit Heaters are used in many of the country's leading industrial plants. Write for a list of installations.

**Wing**  
*Revolving*  
**UNIT HEATERS**

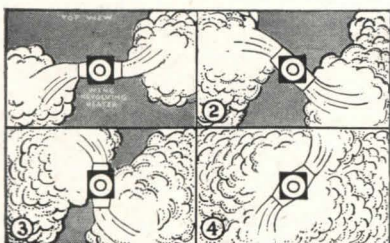

1. Heater starts. 2. 15 seconds later, 45° revolution. 3. 30 seconds later, 90°. 4. 45 seconds later, 135° revolution.

Wing Revolving Unit Heaters keep the heated air moving, circulating around obstacles, seeking out far corners, spreading an even, uniform, healthfully invigorating blanket of warm air over the entire working area.

Write for Bulletin HR-5

**L. J. Wing Mfg. Co.**

151 W. 14th ST., NEW YORK 11, N. Y.

Factories in Newark, N. J. and Montreal, Canada

equipped with a brush holder. Wet brushes are suspended in the liquid which reportedly draws off all pigment from the bristles safely and quickly. The solvent may be used over and over, and for the simultaneous cleaning of brushes used for different colors. The Howe Co., 94 Leete's Island Rd., Stony Creek, Conn.

**SHOWER FLOOR**

A non-slip floor is featured in the *Adapto receptor* for built-in shower stalls. The receptor is of one-piece construction, made of porcelain enamel on steel, with a patterned safety tread. Delivery will be made shortly in two sizes—32 in. square and 34 in. square: later a 36 in. size will be available for corner-entrance stalls. Bathe-Rite Div., Milwaukee Stamping Co., 824 72nd St., Milwaukee 14, Wis.

**GLASS JALOUSIE**

A glass type of jalousie window, known as the *Pro-Tect-U Venetian Window*, has been developed for houses in southern regions. Louvers are of plate glass, 4½ in. wide and hinged on 4-in. centers, that can be opened or closed to control ventilation by means of a brass rod and pinion gear operator. When fully open, 90 per cent of the window area is open to air currents. It is not necessary to close the window during ordinary rains as each projecting vane acts as a miniature awning. When closed and locked in place they serve as protection against heavy rainstorms. The supporting frame with mechanism is installed during construction and the glass vanes after completion of plastering and stuccoing. A removable screen frame is provided. Maximum width of each unit is 3 ft., but it may be any height. Stock sizes correspond approximately to standard double steel casement sash. Pro-Tect-U Jalousie Corp., 2763 S.W. 10th St., Miami 35, Fla.

**ATTIC FAN**

A newly announced air changer, primarily for attic installation, features aluminum construction and quiet operation. The unit creates a circulation of air through the house, drawing in air through open windows and expelling it from a grille in the attic or other location. Paddle wheel blades of the unit are acoustically treated and moving parts are "floated" in rubber. The 36-in. air changer is powered by a ½-hp motor and is said to cost about 1½ cents an hour to operate. Eagle-Picher Sales Co., Cincinnati, Ohio.

(Continued on page 148)

**VAPOR Condensation  
Child's Play Here**

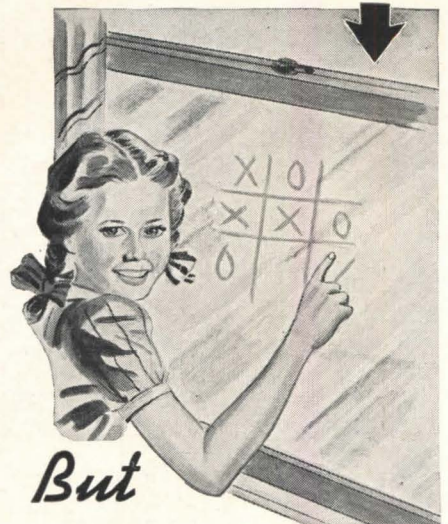

*But*

**A 4-way Evil  
Within Walls**

Moisture condensation on windows may be "child's play," but it can cause these costly evils within walls:

1. Soggy, inefficient insulation
2. wall staining
3. paint peeling
4. structure rot

A sure way to lick this 4-way evil of "in-wall" condensation is with a separate vapor barrier. Standard with architects everywhere is Bird Neponset Black Vapor Barrier. Applied on the warm side of insulation, Bird Neponset Black repels vapor, keeps insulation at peak efficiency, ends the other "in-wall" evils. Low cost—only about \$20 to protect a \$10,000 building. See Sweet's Architectural file, 9b-2. For sample, write Bird & Son, inc., 177 Wash. St., East Walpole, Mass.

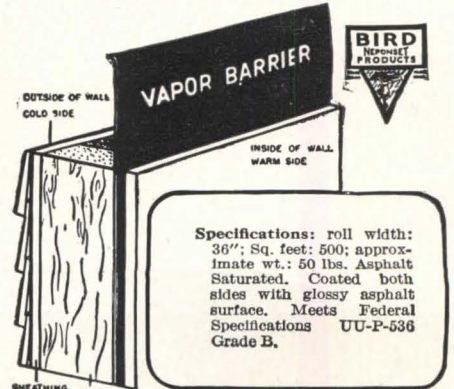

Specifications: roll width: 36"; Sq. feet: 500; approximate wt.: 50 lbs. Asphalt Saturated. Coated both sides with glossy asphalt surface. Meets Federal Specifications UU-P-536 Grade B.

**BIRD NEPONSET BLACK  
VAPOR BARRIER**

**BIRD & SON inc., E. WALPOLE, MASS.**  
CHICAGO NEW YORK SHREVEPORT



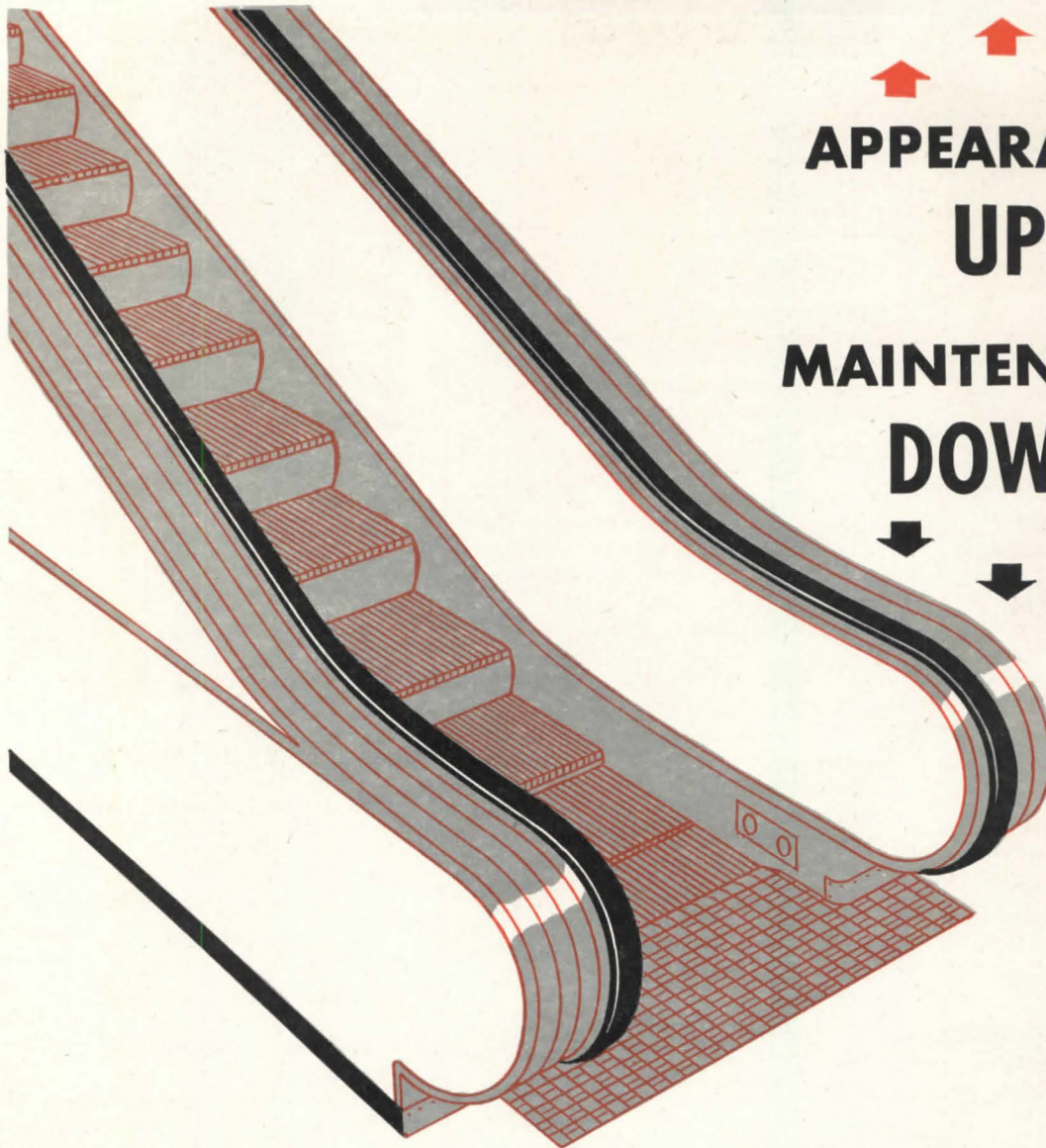

↑ ↑ ↑  
**APPEARANCE  
 UP**

**MAINTENANCE  
 DOWN**  
 ↓ ↓ ↓

**WITH ALCOA ALUMINUM!**

Used for decorative effect, the smooth, gleaming finish of Alcoa Aluminum blends perfectly with modern design. But there is more than good appearance to recommend the use of Alcoa Aluminum for building interiors or exteriors.

To the building operator it brings freedom from maintenance troubles. Aluminum can't rust, warp or chip. It does not require painting. With patented Alumilite\* finish, Alcoa Aluminum retains its good looks after long exposure to weather and wear.

\*Reg. U.S. Pat. Off.

Its soft, satin-like surface does not readily show finger marks or smudges.

Wherever your plans call for good appearance with a minimum of maintenance, consider Alcoa Aluminum. Alcoa has co-operated with architects on many design and engineering problems. We will be glad to work with you. For information on any application of aluminum, write to ALUMINUM COMPANY OF AMERICA, 1867 Gulf Bldg., Pittsburgh 19, Pennsylvania. Sales offices in leading cities.

**MORE** people want **MORE** aluminum for **MORE** uses than ever

**ALCOA** **FIRST IN**  
**ALUMINUM**

REG. T. M.



**IN EVERY COMMERCIAL FORM**



## ARCHITECTURAL ENGINEERING

TECHNICAL NEWS AND RESEARCH

(Continued from page 146)



### CLIPPER SMALL ROOM VENTILATORS

The heat this month emphasizes the need for *good* ventilation in the kitchen or other small rooms.

Patented Clipper Blowers are specially designed for home kitchens, bathrooms, dens . . . as well as for ticket booths, X-ray rooms, toilets, clinics—in fact any small room. They are mounted in the ceiling between joists and vented outside—they trap and expel unwanted air, heat and odors the instant they rise. Only an inconspicuous "dripless" ceiling grille is visible, yet motor and blower assembly are instantly removed without tools for service.

Unlike any other equipment, the Clipper Blower is a complete packaged ventilator in which the motor is entirely removed from the air stream—away from all contaminated air. This means greater efficiency, longer life and easier servicing.

Clipper Blowers are available at electrical dealers from coast to coast, or write us for literature and specifications.

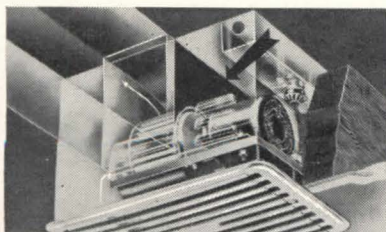

Only the Clipper has this patented inner wall construction. Hot, greasy air never contacts motor or wiring. This means a cooler, longer-life motor, less service and more satisfied customers.

**TRADE-WIND** MOTORFANS, INC.  
5707 SO. MAIN ST., LOS ANGELES 37, CALIF.

### ALUMINUM PAINT

*Prufcoat*, an aluminum protective coating material, features a special corrosion-proof vehicle that is said to protect the leafed aluminum from dulling. It reportedly can be applied to any general maintenance surface that is dry and reasonably free of rust and foreign material. Prufcoat Laboratories, Inc., 63 Main St., Cambridge 42, Mass.

### INDICATOR RULE

A new drafting accessory consists of a standard rule equipped with a metal rail on which point indicators slide, permitting user to make and hold points. Chowns Mfg. & Design Co., 16535 Manchester, East Detroit, Mich.

### PATHWAY LIGHT

The *Cannon Pathfinder Light* is designed for use along paths, driveways, terraces or wherever illumination is required in moderate volume for safety or decorative purposes. It will not replace floodlights or other bright lighting. The complete assembly consists of head or lighting unit, riser conduit, and a canopy base with an outlet box and 7-in. spike. Conduit is not included. Light unit is furnished for low-voltage or standard 100-volt circuits. It is attractively housed and stands about knee high. Cannon Electric Development Co., Dept. AR, 3209 Humboldt St., Los Angeles 31, Calif.

### FLUORESCENT DIFFUSERS

The *Tulox Diffuser* is a plastic cylinder that fits over fluorescent tubes to give a more diffused light; manufactured in clear plastic and five basic colors. Extruded Plastics, Inc., New Canaan Ave., Norwalk, Conn.

### STANDARDS

#### Plumbing Fixtures

A revised Commercial Standard, CS20-47, "Staple Vitreous China Plumbing Fixtures," after acceptance by a majority of manufacturers, distributors, and users, is now in effect for new production. National Bureau of Standards, U. S. Dept. of Commerce, Washington 25, D. C.

#### Correction

The new Commercial Standard, CS140-47, "Testing and Rating Converters," which was announced in *ARCHITECTURAL RECORD*, May 1947, page 176, will not go into effect until March 1, 1948. National Bureau of Standards, U. S. Dept. of Commerce, Washington 25, D. C.

## Saks Fifth Avenue, Another Webster Moderator System



SAKS & COMPANY, Fifth Avenue, New York, N.Y. Built 1924. Architect: Starrett and Van Vleck. Heating Contractor for original installation: Gillis and Geoghegan. Heating Modernization 1944 by Contractor Thomas J. Dorsey, Inc.

From the time Saks Fifth Avenue, the "world's most luxurious store", was built in 1924 reliable heating has been provided with a Webster Vacuum Steam Heating System.

In 1944, to cooperate in the wartime fuel conservation program, Saks discontinued their oil burning boiler plant, arranging to use metered steam purchased from the New York Steam Corporation.

To assure minimum steam charges at all times the installation was converted to a Webster Moderator System. Radiator valves were equipped with expertly sized Webster Metering Orifices. Automatic continuous "control-by-the-weather" was provided by the Outdoor Thermostat.

Under the competent operation of the Engineering Department of Saks Fifth Avenue the Moderator System affords comfortable heating regardless of outdoor temperatures. "Operability" of the System is demonstrated by the fact that each year since its installation, economy in steam consumption has increased.

If your heating system is without control, or with inadequate control, we solicit the opportunity to go over your problem with you. Use our experience to help you in your heating management problems.

WARREN WEBSTER & CO., Camden, N.J.  
Representatives in principal U. S. Cities : : Est. 1888  
In Canada: Darling Brothers, Limited, Montreal

**Webster**  
HEATING SYSTEMS



**Duran**  
all plastic  
FOR UPHOLSTERING

*Versatility*

In many lovely colors and grains, DURAN all-plastic offers the architect, designer and decorator almost unlimited scope in creating new and different effects where functional design and beauty are combined. Pliable, hard wearing and easy to wash, DURAN can be beautifully tailored on furniture and panelling of all types. DURAN is all-plastic, not a coated fabric—it will not chip or peel. National advertising is now telling your clients about DURAN. Write for full information.



*Novel and effective use of Duran on stairwell in Futura, the Westchester Exhibition Home of Eastman Associates at Port Chester, New York.*



**THE MASLAND DURALEATHER COMPANY • 3236-90 Amber Street, Philadelphia 36, Pa.**



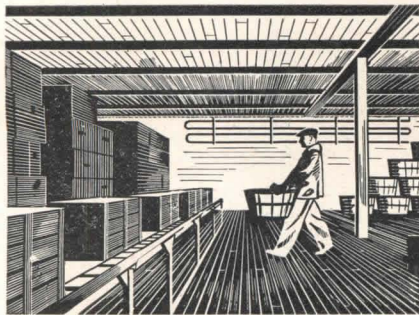

## Cold Storage Plants Offer Hot Tip On Wood Construction

**WOLMANIZED LUMBER\*** adds long life to the other advantages of wood construction; that's the verdict of cold storage and ice plant operators after observing its fine performance for the past nineteen years. They've used hundreds of thousands of feet of Wolmanized Lumber for cold-room floors, framing and linings.

**WOOD CONSTRUCTION** puts cold storage within reach of many fruit and vegetable growers, by cutting the initial cost of these plants. Wolmanized Lumber assures low upkeep costs, because this wood is able to withstand the high humidities encountered. Its insulating properties give added operating economies.

**WOLMANIZED LUMBER** is ordinary lumber which has been made resistant to decay and termite attack by vacuum-pressure impregnation with Wolman Salts\* preservative. It adds little to the first cost of a structure—is light, strong, resilient. It goes up quickly and easily and is clean, odorless and paintable.

**HAVE YOU A PROBLEM** which might be solved with Wolmanized Lumber? We'll gladly send you additional data on its use. Write American Lumber & Treating Company, 1679 McCormick Building, Chicago, Illinois.

\*Registered Trade Mark

*Wolmanized*  
**LUMBER**



(Continued from page 124)

### WINDOWS

**Aluminum Windows of Alcoa Aluminum.** Booklet describing a line of aluminum windows, double hung and picture. Includes full size details, installation details, specifications, and brief description of combination aluminum screens and storm sash also offered in the line. Cupples Products Corp., 2650 S. Hanley Rd., Maplewood, St. Louis 17, Mo.\*

### WELDING

**Nelson Electric Arc Stud Welder.** The application of stud welding in the construction industries. Brochure describes the features of Nelson Stud Welding machines and flux-filled studs, shows operation, applications, line of studs available. Uses include securing corrugated asbestos and other types of roofing and siding, metal lath, insulation and other integral construction materials to structural steel frame. 40 pp., illus. Nelson Sales Corp., Lorain, Ohio.

### WIRING

**Are You Going to Build, Modernize or Repair?** Room-by-room check-up on home lighting and electric needs. Rooms covered are hallway, dining room, kitchen, laundry, living room, bedroom, closets, bath, hobby room. Adequate wiring is specified for each. 24 pp., illus. Pass & Seymour, Inc., Dept. R, Solvay Station, Syracuse 9, N. Y.\*

**Wiremold Catalog and Wiring Guide No. 17.** Pocket-size catalog giving up-to-date information on wire capacities of Wiremold Raceways including the new small diameter Types T and RU conductors, and a complete listing of all Wiremold interconnecting fittings and fluorescent fixtures. 136 pp., illus. The Wiremold Co., Hartford 10, Conn.

### LITERATURE REQUESTED

The following individuals and firms request manufacturers' literature:

Gregory Ain, Architect, Joseph Johnson and Alfred Day, Collaborating, 2404 W. 7th St., Los Angeles 5, Calif.

James W. Darling, Engineer, Manila Engineer District, APO 900, c/o Postmaster, San Francisco, Calif.

Leon Halsband, Civil Engineer, Pasteur 772, dep. B, Buenos Aires, Argentina.

Ben B. Milam, Architect, Guaranty Bldg., Galveston, Texas.

C. J. Ryland, Architect, 467 Alvarado St., Monterey, Calif.

## Announcing

IN A NEW, REVISED,  
1947 EDITION . . .

# THE MODERN HOUSE

by F. R. S. YORKE, A.R.I.B.A.

• This home building classic, with its collection of the finest examples of modern residential architecture, from the United States, England and Continental Europe, has undergone an up-to-the-minute revision.

### For Architects, Students, Home Builders

Although illustrated with hundreds of fine photographs, this book is no mere collection of startling pictures. Materials and construction methods are analyzed for each house, and preliminary chapters discuss walls, windows, roofs and planning in relation to twentieth century homes.

Because it is published in England (by the Architectural Press) under severe manufacturing difficulties, only a limited number of copies of THE MODERN HOUSE will be available for some time to come. To get your copy, order it now from ARCHITECTURAL RECORD, sole distributor, using the coupon below.

Price: \$6.50

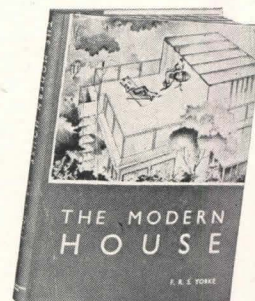

Book Department,  
*Architectural Record*  
119 West 40th Street, New York 18, N. Y.  
Please send . . . . . copy(s) of THE  
MODERN HOUSE for which I enclose  
\$ . . . . .  
(For N. Y. City Delivery add 2% Sales Tax)

Name . . . . .

Address . . . . .

City . . . . . Zone . . . . . State . . . . .



**Best**

# for Radiant Baseboards

... AS WELL AS FOR RADIATORS, CONVECTORS AND RADIANT PANELS

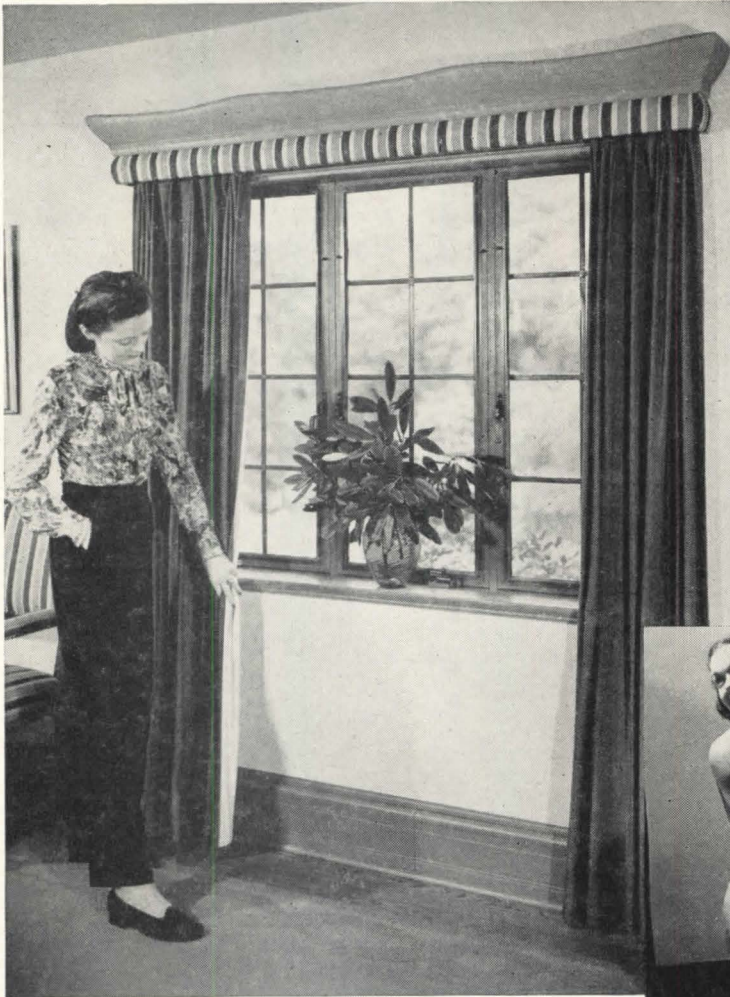

Radiant baseboards mark a new advance in the art of creating comfort with radiant heat. And—just as for radiators, convectors and panels—B & G *Hydro-Flo Heat* brings full realization of the many benefits made possible by radiant baseboards.

B & G *Hydro-Flo Heat* takes full advantage of the *basic superiority of forced hot water* as a heating medium. It establishes ideal comfort conditions because of its ability to measure out heat in the exact quantities required by the weather. When the outdoor temperature becomes colder, the average temperature of the water in the system is automatically increased to compensate for the greater heat loss. If the weather turns mild, the temperature of the circulating water is lowered accordingly.

The net result of this *variable* water temperature is a *uniform* room temperature, regardless of weather changes. It obviously means greatest operating economy, as only *just enough* fuel is burned to satisfy the heat demand.

### B & G *Hydro-Flo* Heating Systems have universal application

Hundreds of thousands of B & G *Hydro-Flo* installations are in successful operation today . . . in homes . . . in apartments . . . and in low cost housing developments where economy of operation is an essential to owners with modest incomes.



### PLUS THIS EXTRA FEATURE!

**Year 'round hot water from the same boiler that heats the house**

Here's the feature that makes women enthusiastic about B & G *Hydro-Flo Heat*! The automatic controls of the system permit operation of the B & G Water Heater not only during the heating season but every month of the year. Virtually limitless quantities of low cost hot water are available at all hours of the day and night.

Hence every household task from dish washing to house cleaning is shortened, made easier. Every gratifying little luxury of personal care and cleanliness can be enjoyed to the utmost . . . and there's always plenty of hot water for such modern labor-saving devices as dish and clothes washers.

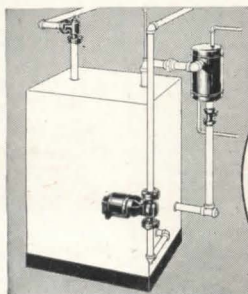
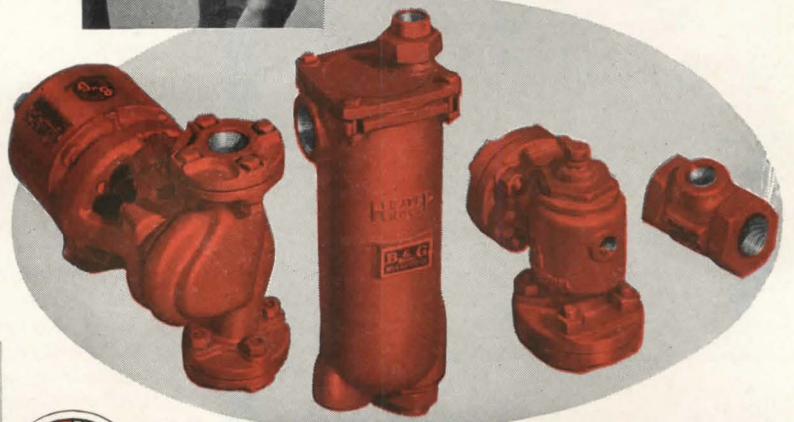

The simple, dependable equipment of a B & G *Hydro-Flo* Heating System can be installed on any hot water heating boiler.



*B & G Hydro-Flo Heat equipment can be installed on any hot water heating boiler. It is simple and dependable, with an established record for long, carefree service.*

## **Hydro-Flo** HEA

**BELL & GOSSETT COMPANY**

Dept. AD-32, Morton Grove, Illinois

\*REG. U. S. PAT. OFF.



No Electrical or Heating Troubles Here!

HOTEL  
EMPIRE

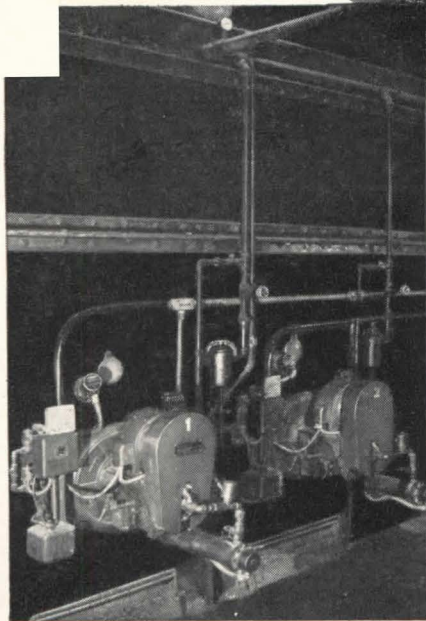

These are two of the six ENTERPRISE Oil Burners installed at the Hotel Empire by Enterprise Engineering Co., Inc., Brooklyn, New York.

## A battery of ENTERPRISE Oil Burners meets rigid requirements with ease

*THE HOTEL EMPIRE* in New York found the solution to their complete heating and electrical problems last year when they installed six modern ENTERPRISE Oil Burners. Four of these heavy-duty belt-drive burners are semi-automatic in operation, two are full-automatic. Capable of developing a total of approximately 1000 HP, these economical units produce steam to generate the necessary current to carry the electrical load. Exhaust is utilized to provide constant, uniform heat to every room in the building.

ENTERPRISE Oil Burners are furnished in Manual, Semi-Automatic and Fully-Automatic models in combinations and sizes to meet all commercial and industrial requirements. For complete information on the oil burners that offer outstanding efficiency, flexibility, cleanliness and low-cost operation and maintenance, contact your nearest ENTERPRISE Distributor, or write the Combustion Equipment Division.

**ENTERPRISE**  
*Oil Burners*

COMBUSTION EQUIPMENT DIVISION OF  
ENTERPRISE ENGINE & FOUNDRY CO.,  
18TH AND FLORIDA STREETS  
SAN FRANCISCO 10, CALIFORNIA

*Distributors in Principal Cities*

OIL BURNERS

DIESEL ENGINES

PROCESS MACHINERY



# Power takes a trolley ride\*

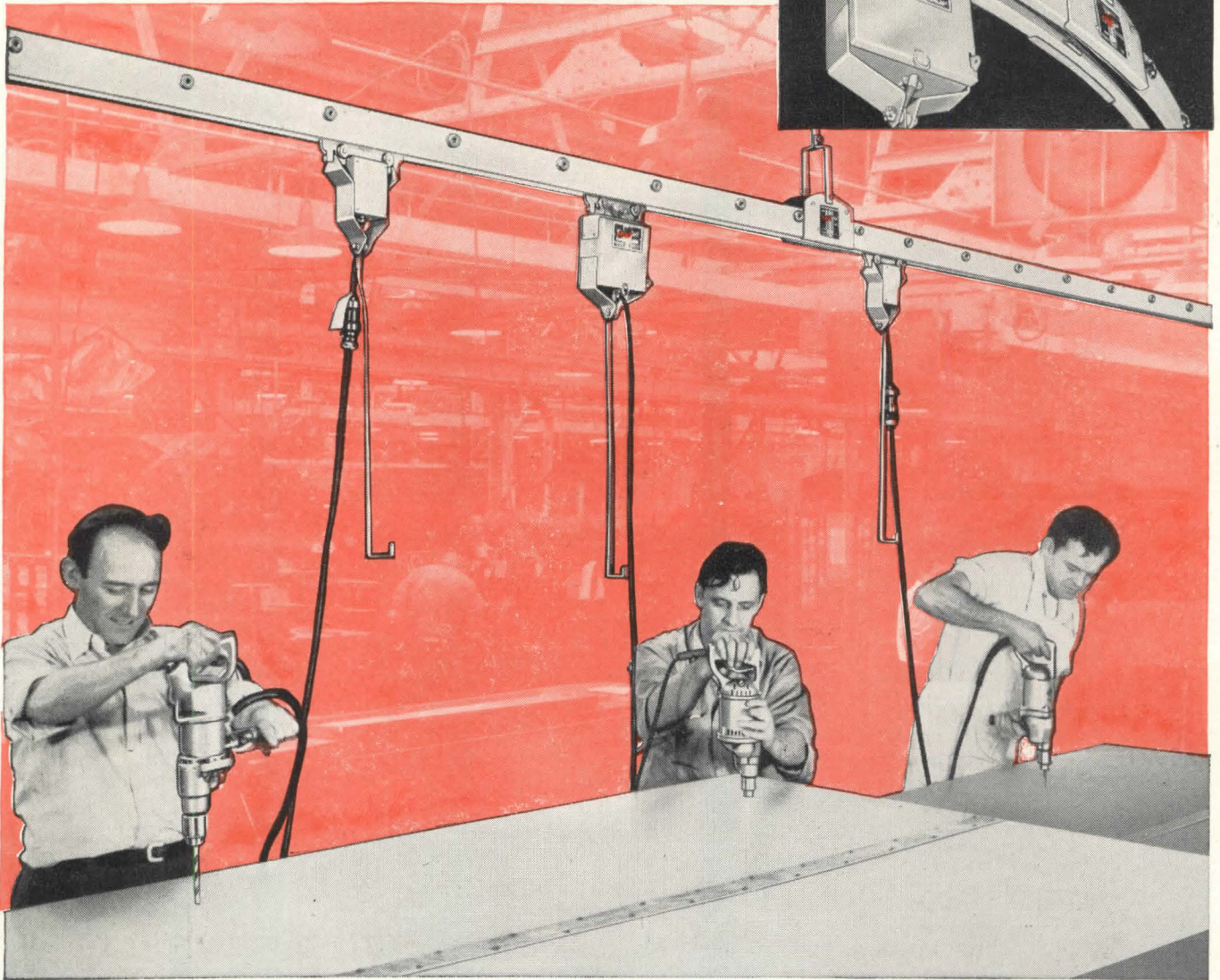

**P**OWER travels with the job when cranes, hoists and portable tools are electrified by Bulldog Industrial Trol-E-Duct.

It takes only an eight-ounce pull to put power at a workman's elbow—with no danger from entangling extension cords and no possibility of accidental contact with "live" wires.

The moving trolleys, collecting current from bus bars enclosed in a rigid steel duct, provide a source of power that is safe, convenient and economical.

Slotted its entire length, Industrial Trol-E-Duct provides a continuous electrical outlet that completely eliminates the

need of rewiring or adding new fixed outlets. Maintenance costs are minimized, because all current-carrying bus bars are firmly supported in the duct casing and long extension cords are unnecessary.

Your clients' plants can have all the advantages of this modern electrical distribution system if you consult a Bulldog Field Engineer right away. He'll give you full technical information and show you a Bulldog installation near your own office. Or, if you'd like descriptive literature, write Bulldog direct.

**\*With Bulldog Industrial Trol-E-Duct**



## BULLDOG

**ELECTRIC PRODUCTS COMPANY**



Bulldog manufactures Vacu-Break Safety Switches — SafToFuse Panelboards — Superba and Rocker Type Lighting Panels — Switchboards — Circuit Master Breakers — "Lo-X" Feeder BUSTribution DUCT — "Plug-in" Type BUSTribution DUCT — Universal Trol-E-Duct for flexible lighting — Industrial Trol-E-Duct for portable tools, cranes, hoists.

Detroit 32, Michigan. Field Offices In All Principal Cities. In Canada: Bulldog Electric Products of Canada, Ltd., Toronto.



# UP-TO-DATE use of *Glass* in



Customers linger longer—and buy more—in attractive, up-to-date stores. The proper application of mirrors can do much to enhance the decor of any interior. "Pittsburgh" offers regular polished Plate Glass, and blue, green and flesh tinted Plate Glass with silver, gold or gunmetal backing . . . a wide range to meet any design problem. Architect: K. C. Welch.

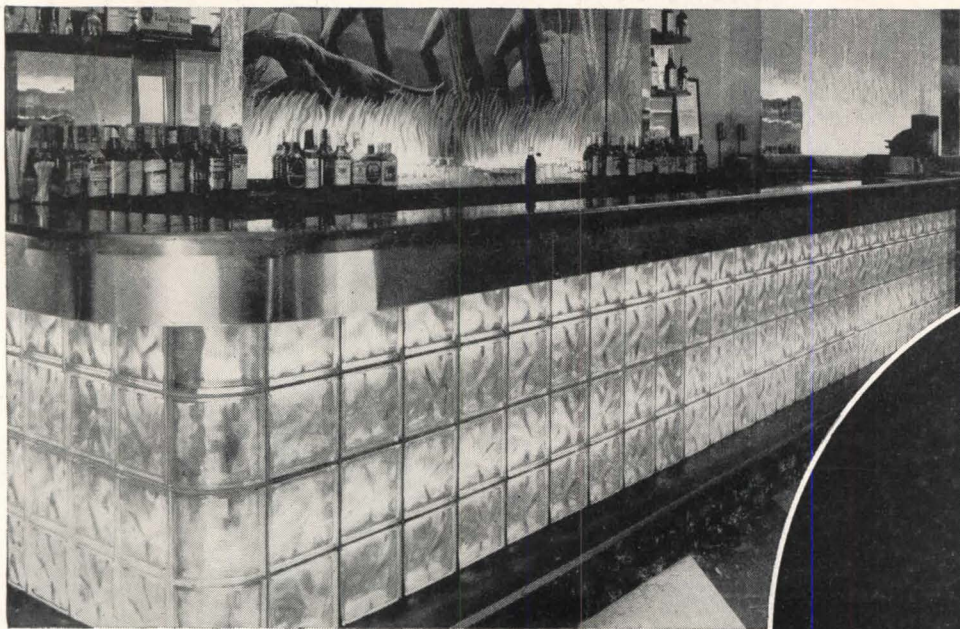

PC Glass Blocks are an increasing favorite with architects and builders. Easy to install and easy to clean, they combine modern good looks with exceptional versatility. They transmit daylight generously. They preserve privacy. They aid temperature control. And they can be used decoratively, as in the bar at left, with striking effect. Architect: Frank Smart.

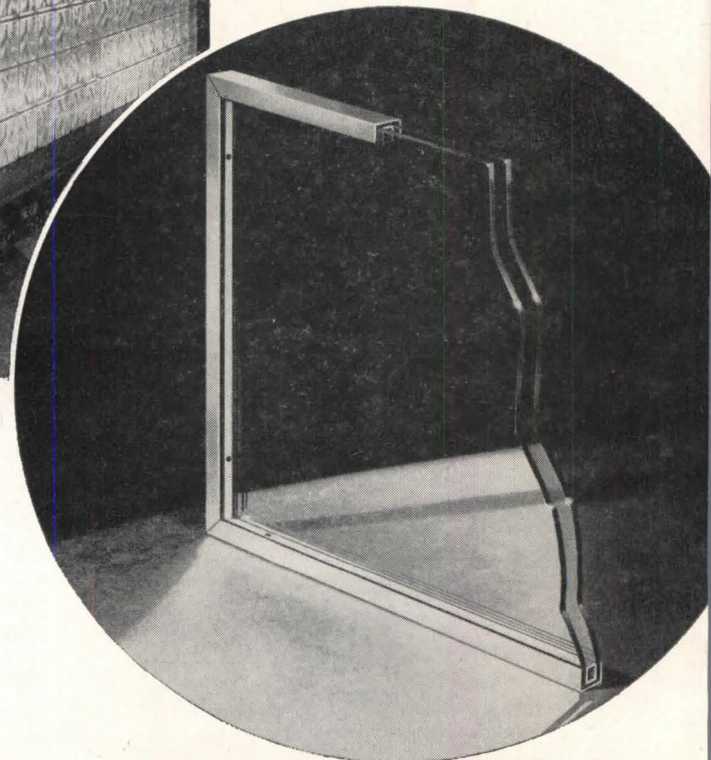

→  
**Twindow**—"Pittsburgh's" new window with built-in insulation, consists of two or more panes of "Pittsburgh" Glass separated by hermetically sealed air spaces, and enclosed in a protecting frame of stainless steel. The 2-pane Twindow unit cuts heat loss through windows nearly in half—and has even greater insulating effectiveness when made with three or more panes of glass. It minimizes downdrafts near windows, contributes increased comfort as well as economy to stores, hotels, restaurants, office buildings and factories.

PITTSBURGH PLATE GLASS COMPANY



# Commercial buildings

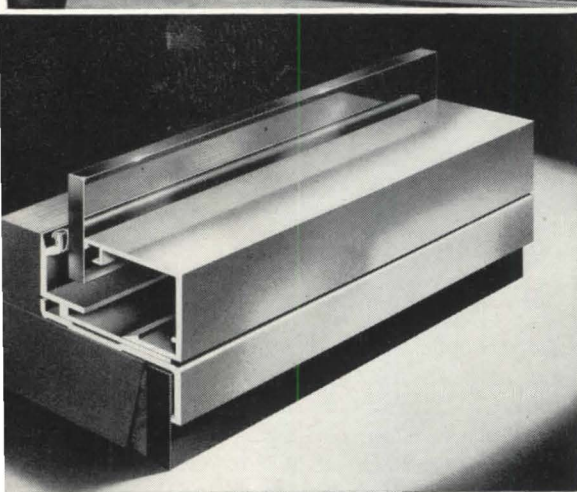
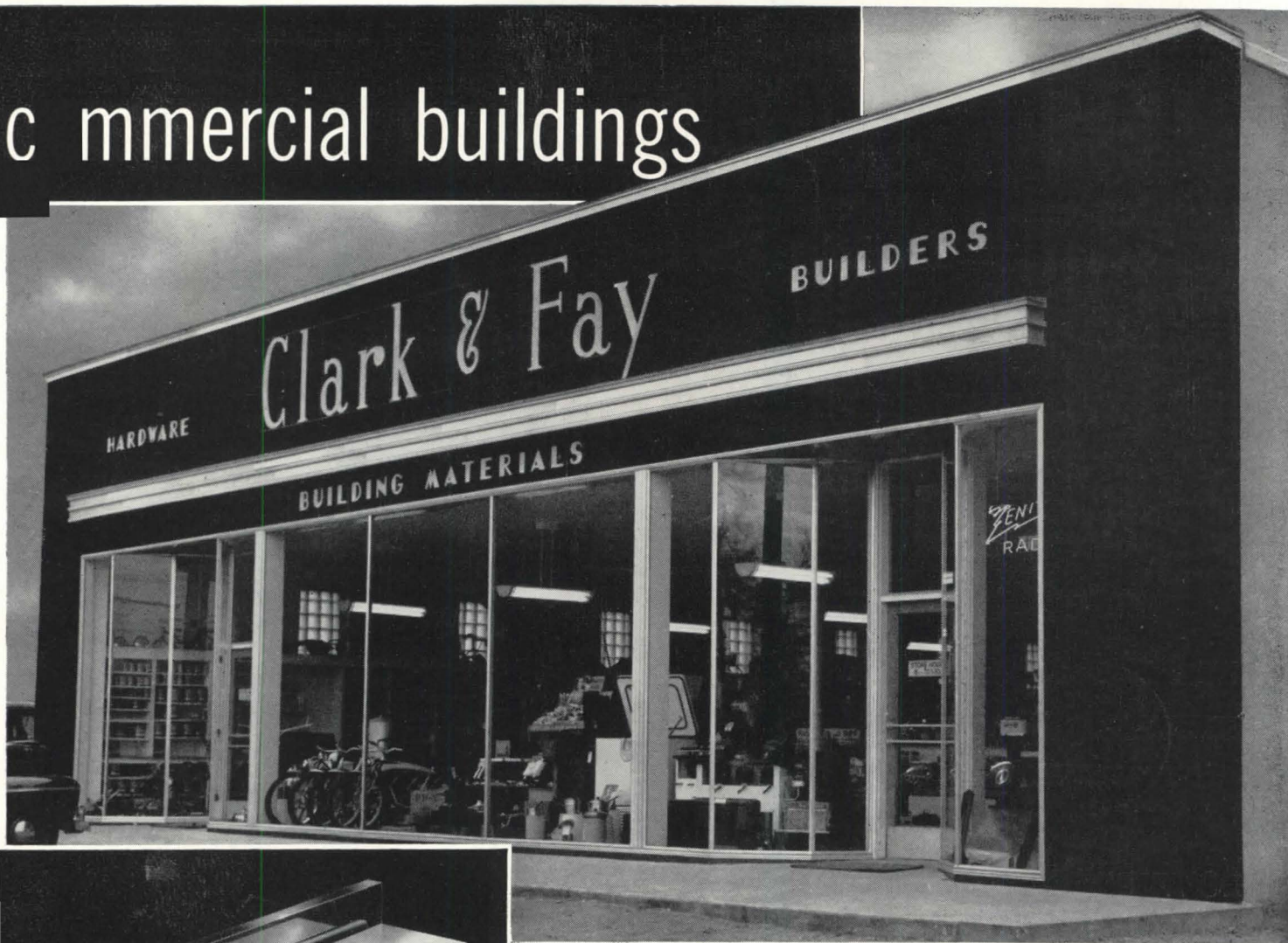

"Open vision"—the new trend in store design—has emphasized the need for quality in the glass products used to build distinctive store fronts and interiors. "Pittsburgh" products, such as Carrara Structural Glass, Polished Plate Glass, Pittsburgh Mirrors, Herculite Tempered Plate Glass and Twindow, the window with built-in insulation, have proved themselves outstanding quality leaders in the store field. You can depend upon them for the faithful and effective execution of your store designs. Architect: Austin K. Hall.

← This rectangular sash is a recent addition to the Pittco De Luxe Store Front Metal line. It gracefully harmonizes with modern store front design. Its extruded method of manufacture assures rugged strength and a clean, sharp profile. Its beauty and practical utility are typical of the Pittco De Luxe line. Where economy is of prime importance, Premier, the other Pittco line of store front metal, is the ideal choice.

We believe you will find much to interest you in our illustrated booklet of ideas concerning the use of Pittsburgh Glass in building design. Send the coupon for your free copy.

★ Design it better with

# Pittsburgh Glass



"PITTSBURGH" stands for Quality Glass and Paint

PITTSBURGH PLATE GLASS COMPANY

Pittsburgh Plate Glass Company  
2176-7 Grant Building, Pittsburgh 19, Pa.

Please send me, without obligation, your free booklet entitled "Ideas for the Use of Pittsburgh Glass in Building Design".

Name.....

Address.....

City..... State.....





## How to Keep a Home Owner Free of a "Ball and Chain"

• Architects and builders are well aware that Bituminous Coal is the most economical and most dependable of all home-heating fuels.

And the advantages of coal heat become even more obvious as stoker developments make coal an "automatic" fuel as well.

So what can you do when a client *insists* on some other fuel for his new home? Simply this—keep him free of a "ball and chain" by making it possible for him to change his mind later on—and turn to coal.

Just be sure his house plans include: (1) *A chimney with sufficient flue capacity to burn coal efficiently;* (2) *Sufficient space adjacent to the heating unit for eventual coal storage and stoker installation.*

These sensible precautions involve but trifling cost—and they may add greatly to the future value of a house.

Coal supplies uniform, *steady* warmth throughout every portion of each room. For there's always a fire in the furnace—no "pop on and pop off" periods that permit accumulated heat to rise to the ceilings and leave floor areas dangerously cold. That, plus its low cost, is why more than 4 out of every 7 homes in the United States now heat with coal!

**BETTER AND BETTER THINGS ARE COMING FROM COAL!**



As you undoubtedly know, the modern research facilities of the Bituminous Coal industry are hard at work not only to make coal a still better fuel, but also to devise new, low-cost *automatic* equipment that will make coal-heating even cleaner, more comfortable, more convenient, and more economical. This makes it all the more important that every new home built today be planned to permit the eventual burning of coal—no matter what fuel may initially be selected.

**BITUMINOUS  COAL**

**BITUMINOUS COAL INSTITUTE  
Washington, D. C.**

**Affiliate of NATIONAL COAL ASSOCIATION**



# WHAT'S MISSING

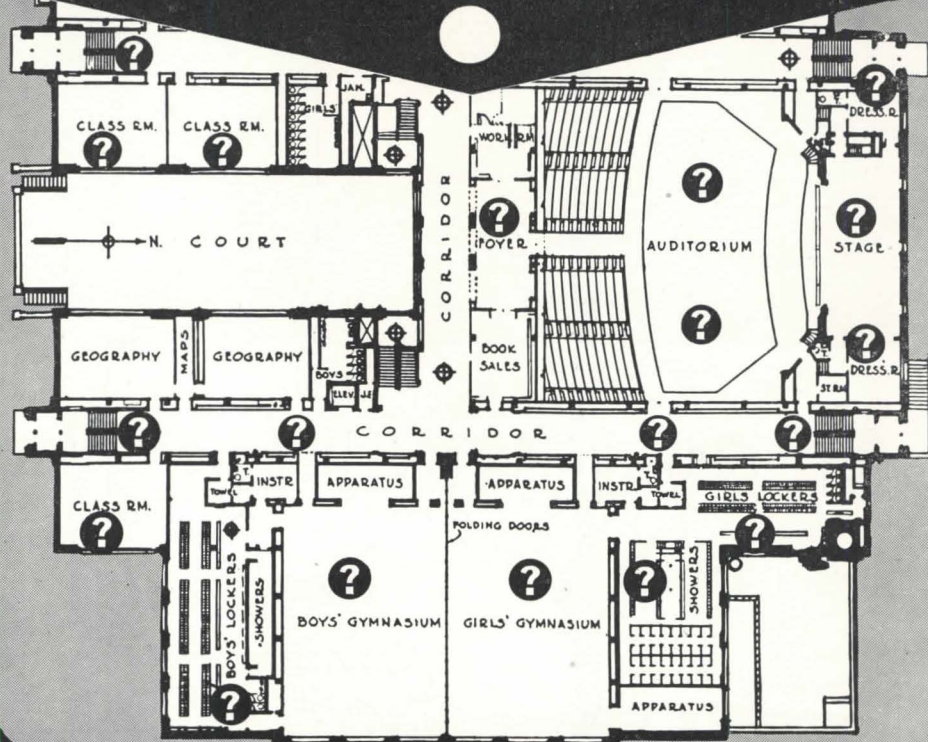

## EMERGENCY LIGHTING PROTECTION SHOULD BE INDICATED AT EACH POINT

In schools, auditoriums, hospitals and other buildings where dependable lighting is essential, adequate safeguards should be provided to offset the dangers that may follow if the normal supply of current fails.

Despite all precautions of utility companies, accidents beyond their control can cause interruptions of normal electric current. Storms, floods, fires and collisions may occur with little or no warning, and are a serious menace to electric power lines.

You can safeguard the buildings you design against such dangers. Exide Emergency Lighting provides safe, sure, modern protection. Batteries are always fully charged and respond *instantly* and *automatically* when needed.

## IN EVERY SCHOOL THESE POINTS NEED PROTECTION

- Assembly Halls
- Auditorium
- Gymnasium
- Class Rooms
- Locker Rooms
- Corridors
- Stairways
- Exits

# Exide

EMERGENCY  
BATTERIES

THE ELECTRIC STORAGE BATTERY COMPANY, Philadelphia 32 • Exide Batteries of Canada, Limited, Toronto



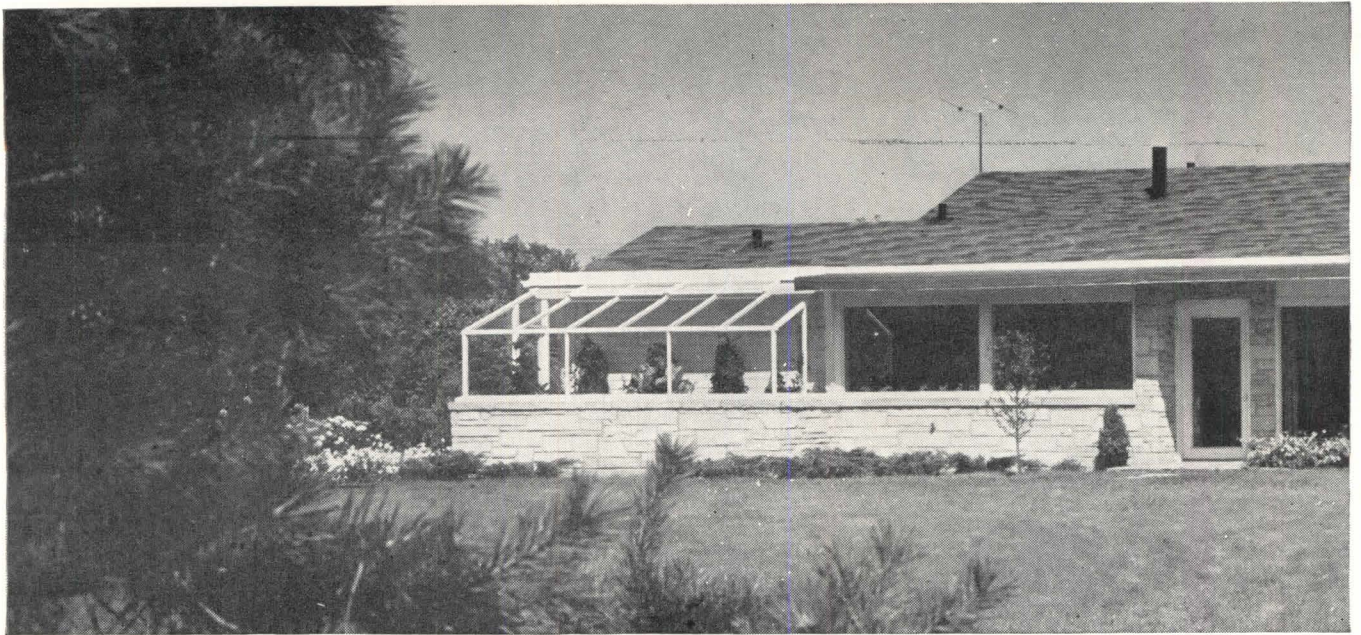

# Many design innovations

*Servel All-Year Gas Air  
Conditioning makes possible  
new high in year-round comfort*

**T**O INSURE maximum physical and psychological comfort in America's first all-sealed house, Howard M. Sloan and his architect, David S. Barrow, used solar heating and Servel *All-Year* Gas Air Conditioning. This unique combination not only provided a "new quality of living" the year round; it also made possible more efficient and economical design and construction.

The Sloan house uses the entire floor area as a radi-



*Reprinted from House & Garden*

Servel-conditioned air emerges from this specially designed grille below living room windows to form a solid curtain between pane and room.

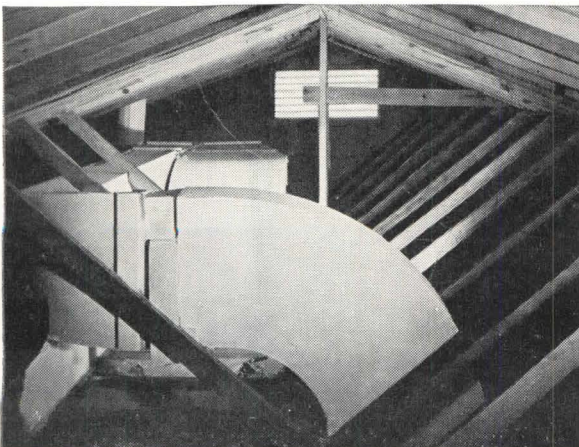

Air returns to the Servel *All-Year* Gas Air Conditioning unit are conveniently placed in the attic.

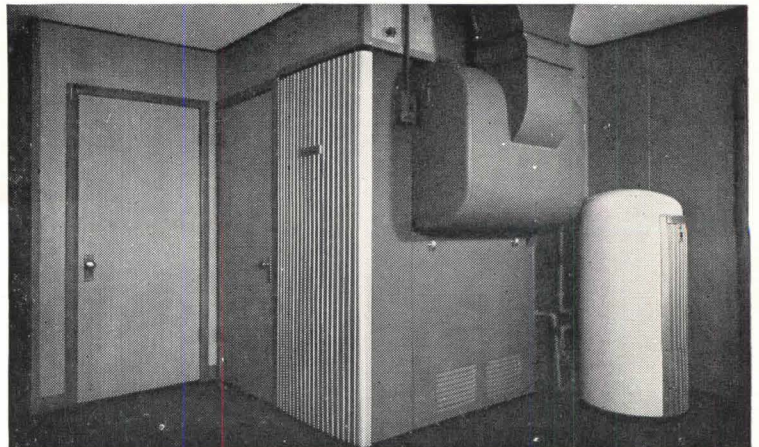

Heart of the solar-radiant heated Sloan house is the Servel Conditioner. At right is Servel Ball-Type Gas Water Heater.



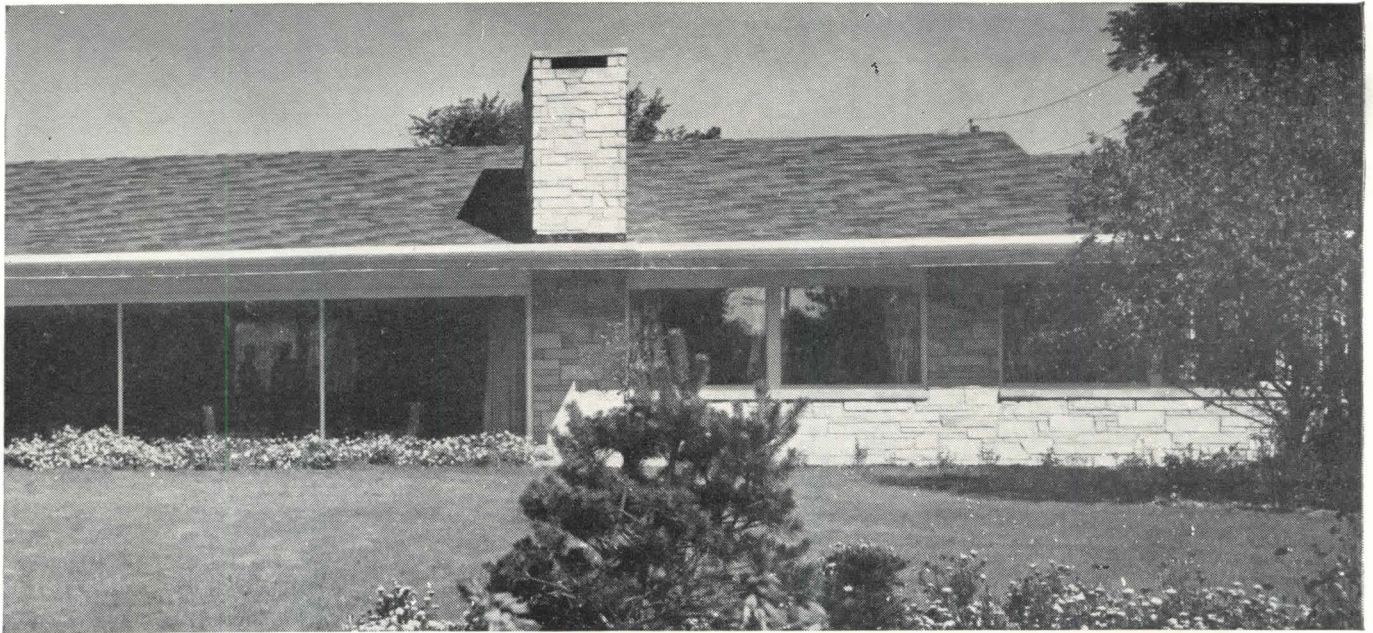

# 'n first all-sealed house

ant heating panel. Six separate ducts bring air from the Servel Conditioner to six plenum chambers under the various rooms. Openings under windows allow conditioned air to circulate from bottom to top of glass areas. It returns through openings in the ceilings. Outside air for ventilation is taken through unit, where it is cleaned and conditioned before being delivered to rooms.

The air supply ducts for the six zones in the house are equipped with splitter dampers where air leaves the Servel *All-Year* Gas Air Conditioner. Thus the flow of air to zones can be adjusted to provide the most desirable year-round temperatures in each room. What's more, distribution of heat generated by the sun is assured by the fan operating continuously in the Servel unit. In this way all rooms are kept at uniform ideal temperature and humidity, in winter as in summer.

Comprehensive tests on typical days show that there

is almost no stratification of air in the rooms. Findings reveal a maximum variation of one degree between floor and ceiling levels. And there is no overshooting of temperatures during normal heating operations.

In addition, the use of fixed windows eliminates window screens, window hardware, weather stripping as well as the need for a screen porch. Mr. Sloan states that "the economies in design and construction made possible by the Servel *All-Year* Gas Air Conditioner actually made it cost little, if any, more than an ordinary heating system!"

The Sloan house is a striking example of how Servel *All-Year* Gas Air Conditioning can help you design greater comfort and livability into any home—without appreciably increasing the cost. Get all the facts from your local Gas Company. Or write today to Servel, Inc., 8708 Morton Avenue, Evansville 20, Indiana.

### TRIED . . . PROVED . . . SUCCESSFUL

(From Boston to San Diego . . . From Bismarck to Miami)

The Servel *All-Year* Gas Air Conditioner is already operating successfully in hundreds of installations from coast to coast. Some have been running for more than seven years. The equipment is tried, tested . . . and approved by users everywhere.

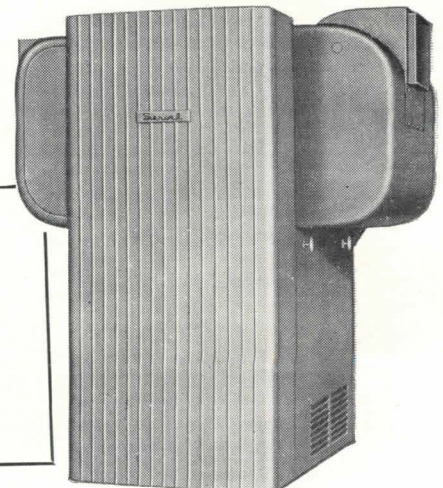

**Servel**  
*All-Year* GAS AIR CONDITIONER





## "above thy fruited plains"

This, too, is America. For true character is no better symbolized than by the fundamental goodness of the soil . . .

And the more than six million fertile farmsteads, peopled with the earthy, land-wise sons and daughters of the country, who multiply the talents of nature to feed and clothe their fellow men. Nowhere does the "nobility of man" find kinder expression!

On the farm, as in industry and commerce, imagination and determination have always mixed freely to achieve our highest aims. But the painful transition from tilling earth with sharpened sticks to roll-

ing the furrows of soil with multiple plows was no harder for the farmer to affect than the change from the sweep well to the automatic water system.

Only the invention and mass production of *steel pipe* finally banished the old oaken bucket and made fresh, pure water under pressure available at the turn of a tap in the house, the barn or the "north forty."

Today America is the "bread basket of the world" largely because *steel pipe* . . . for irrigation, stock watering, spraying, labor saving, sanitation and just plain convenience . . . has made farming a modern industry. It is the medium by which

and through which the energies of water, gas, steam, oil and other resources of America are made the servants of Americans. Yes, *steel pipe makes it possible!*

The interesting story of "Pipe in American Life" will be sent upon request.

*Committee on  
Steel Pipe Research*  
OF  
AMERICAN IRON AND  
STEEL INSTITUTE

350 Fifth Avenue, New York 1, N. Y.

### STEEL PIPE MAKES IT POSSIBLE!



. . . better living through pipes of steel for plumbing and heating purposes.



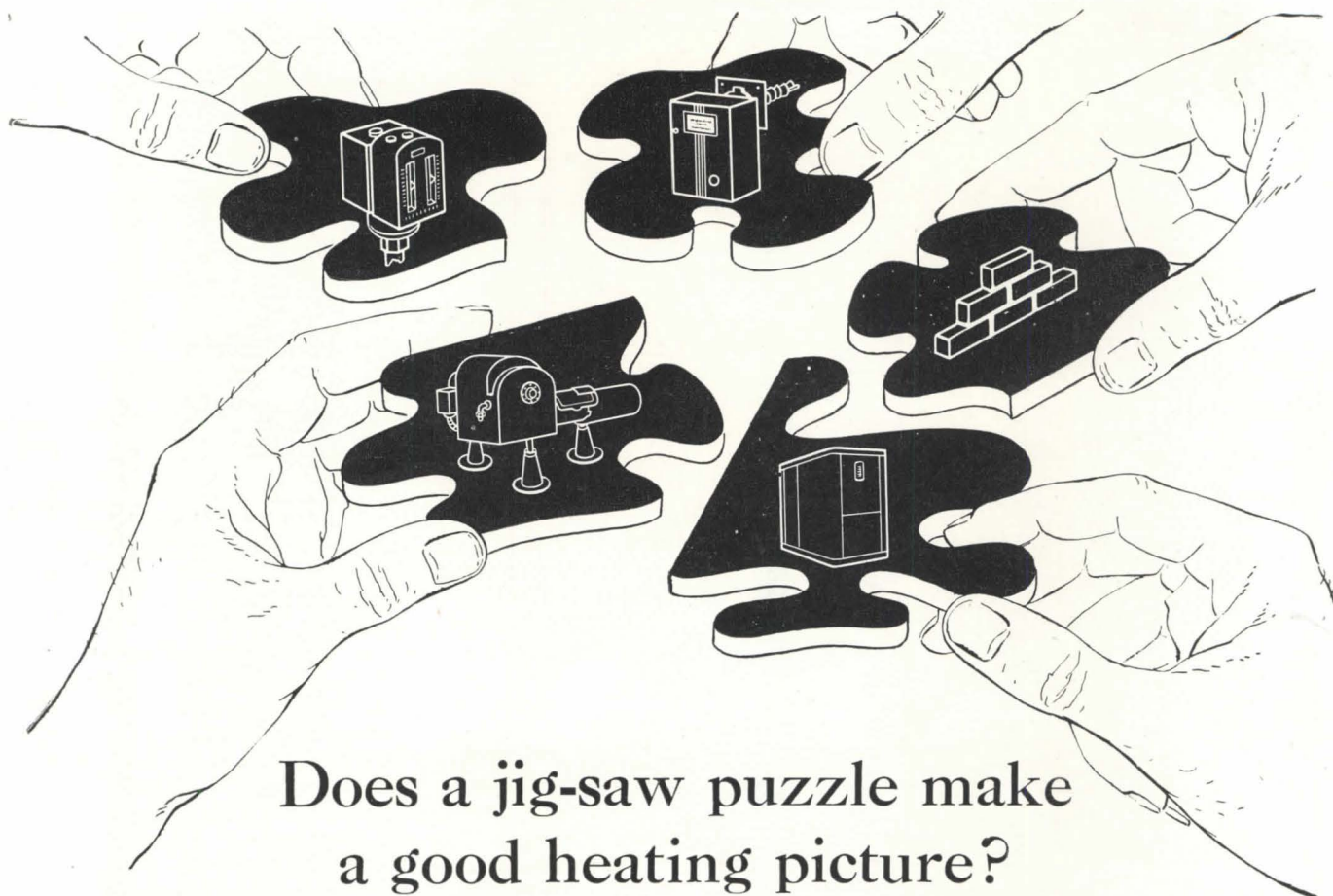

## Does a jig-saw puzzle make a good heating picture?

SOME TYPES of heating equipment are like a jig-saw puzzle. Controls from manufacturer A. Oil burner from manufacturer B. Boiler from manufacturer C. Combustion chamber from manufacturer D. Then, it's left to the dealer to put the pieces together.

But jig-saw puzzle methods *can't* produce the most efficient heating equipment. That's why General Electric boilers and winter air conditioners are:

- *coordinated units*
- *engineered and designed by General Electric*
- *assembled in the G-E factory*

- *tested and installed as a complete, factory-designed unit*

You might suppose that the more efficient, more reliable General Electric heating equipment might be out of line as to price. But it isn't. *G-E heating plants are priced competitively in the better grade heating field.*

For Specifications see Sweets, Section 29A-6. Call your General Electric contractor today for prices and delivery dates. He's listed in the Classified Telephone Directory. *General Electric Co., Air Conditioning Dept., Section 7448, Bloomfield, N. J.*

### Automatic Home Heating

# GENERAL ELECTRIC

#### OIL-FIRED



G-E Boiler for steam or hot water



G-E Warm Air Conditioner



G-E Oil Burner

#### GAS-FIRED



G-E Boiler for steam or hot water



G-E Warm Air Conditioner



# 2nd Printing

## The Complete ... Authoritative up-to-the-minute Handbook

# "Hospital Planning"

by CHARLES BUTLER, F.A.I.A., and ADDISON ERDMAN, A.I.A.

### A Case-Study Analysis of Modern Hospitals

With tremendous energy and insight Charles Butler and Addison Erdman, distinguished architects and hospital consultants, have made a nation-wide survey of the current adaptation of hospital architecture to changing practices in hospitalization.

The fruits of their study are set forth in "Hospital Planning" — a completely new treatise of present-day practices, based on a painstaking study of hundreds of institutions from which have been selected fifty-one modern hospitals, representing the creative efforts of more than thirty architectural firms, for illustration and discussion. "Hospital Planning" presents a textual summation of the outstanding problems in hospital architecture and shows how these problems have been met in actual practice. Generous use of illustrations, including perspectives, floor plans, elevations and photographs, make solutions abundantly clear and afford sound, applicable principles for innumerable problems to come.

**For Hospital Administrators . . . Superintendents  
. . . Doctors . . . Architects**

This 232-page, fully-illustrated volume, carefully organized for both reading and reference, is designed for architects and hospital groups alike. It will help trustees, administrators and doctors to visualize their problems in terms of their community needs . . . show how others are meeting similar problems . . . provide them with a basic understanding of hospital architecture so that they may intelligently discuss their problems with the architect.

It will help architects and engineers to learn of the great advances made in hospital architecture . . . to acquire a working knowledge of medical problems and hospital procedure . . . to avoid the many pitfalls which beset the hospital planner.

### Order Your Copy Now

With this second printing "Hospital Planning" is again temporarily available at the price of \$15. It is offered with the full knowledge that it may be worth incomparably more to you than its cost — so much more that cost is no valid consideration.

So use the convenient coupon below to make sure to get your copy of "Hospital Planning" before the second printing is sold out. The book will be sent promptly, prepaid.

**A FEW** of the architectural firms whose works were selected for discussion and illustration include...

Coolidge, Shepley  
Bulfinch and Abbott  
Samuel Hannaford & Sons  
Schmidt, Garden and  
Erickson  
Jamieson and Spearl  
Charles B. Meyers  
James Gamble Rogers  
Mayers, Murray and  
Phillip  
Eggers and Higgins  
Crow, Lewis and Wick

### Mail this coupon today

ARCHITECTURAL RECORD BOOK DEPARTMENT  
119 West 40th Street, New York 18, New York

Enter my order for . . . . . copy(s) of the new printing of "Hospital Planning" by Charles Butler and Addison Erdman at the price of \$15 a copy. I enclose payment of \$ . . . . . (For New York City delivery, add 30 cents for Sales Tax — \$15.30 in all.)

Name . . . . .  
Address . . . . .  
City . . . . . Zone . . . . . State . . . . .

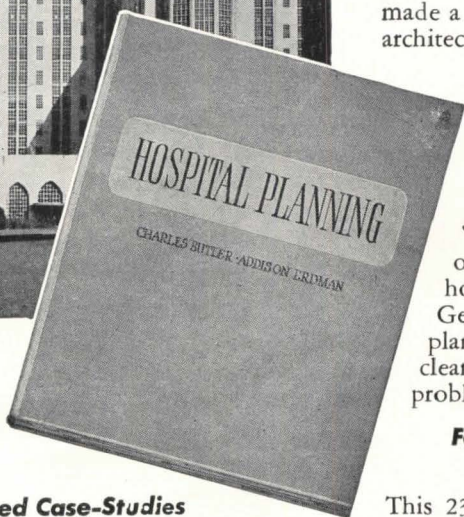

232 pages . . .  
size 8 1/2 x 11 inches . . .  
17 chapters . . .  
profusely illustrated . . .  
thoroughly indexed . . .  
detailed table of contents . . .  
stiff cloth binding . . .  
Price \$15

### Hundreds of Illustrated Case-Studies

"Hospital Planning" presents the plans of fifty-one selected modern hospitals . . . represents the creative efforts of 30 architects. Includes 32 photographs . . . 11 site plans . . . 187 floor plans . . . 38 special unit plans of rooms, wards and departments . . . numerous construction details.

**THE AUTHORS**—Perhaps no other two authors are so well qualified by background and experience to write a volume of such broad scope and magnitude as those selected for this authoritative and technically difficult work.



**Charles Butler** has been closely associated with hospital planning throughout his broad professional career. As architect or consultant, his works include St. Luke's International Medical Center, Tokyo; War Demonstration Hospital at Rockefeller Institute; Goldwater Memorial Hospital.



**Addison Erdman**, holder of the A.I.A.'s Langley Fellowship for two successive years, is a consultant on hospitals for a number of architectural firms. His works include the Mobile Hospital Unit for the British Army in Egypt, the Private Patient Pavilion, Methodist Hospital of Brooklyn. Recently appointed as one of the five architects consultants for the Veterans Administration.

**HOSPITALS** selected for illustration include — Cornell-New York Medical Center, New York; Goldwater Memorial Hospital, Welfare Island, New York; Methodist Hospital, Brooklyn; General Hospital, Cincinnati; Saint Vincent's Hospital, New York; Community Hospital, Battle Creek; Saint Mary's Hospital, Rochester, Minnesota; American Memorial Hospital, Reims, France; Mallinckrodt Institute of Radiology, Saint Louis; Royal Victoria Hospital, Montreal; Rochester Municipal Hospital, Rochester, New York; Potts Memorial Hospital, Livingston, New York; Fort Sill Hospital, Fort Sill, Oklahoma. Saint Luke's Hospital, Spokane, Washington; Massachusetts General Hospital, Boston and many more.



# "I was just a boy back in '47...

**when those Adlake Windows  
were installed!"**



**BUILT FOR A LIFETIME** of service, designed for lasting beauty—*Adlake* Aluminum Windows are today's best window investment!

Only *Adlake* combines non-metallic weather stripping and serrated guides to stop excessive air infiltration and give you finger-tip control. What's more, its lustrous aluminum sash requires no painting or maintenance. No warp, rot, swell, stick or rattle—*ever*.

Truly, the *Adlake* Aluminum Window

fulfills your every architectural requirement! Complete information and data will be mailed you on request. Drop us a post-card today . . . there's no obligation, naturally. Address: The Adams & Westlake Company, 1102 N. Michigan, Elkhart, Ind.

**THE  
Adams & Westlake  
COMPANY**

Established 1857 • ELKHART, INDIANA • New York • Chicago



Furnishers of  
Windows to the Transportation Industry  
for Over 30 Years



# NEW HEATING IDEAS...



## COME OUT OF the WEST

Of signal interest to you who design and build: Pacific has developed—(1) really new performance standards in warm air, automatic gas heat; and (2) distinctive functional styling.

Throughout the nation, our own industry acknowledges the spectacular success of such 1947 Pacific innovations as Duo-Stage Modulation\* and Thermo-flo Heating Element . . . such distinctly original engineering as appears in the new Suspended Unit, the Duct Furnace, the Winter Air Conditioner.

New, yes . . . yet fully proven by many months of rigid testing in the Naco Engineering Laboratories. Today, as for a third of a century, the entire lineup of Pacific Gas Heating Equipment bears the mark of superior engineering.

Learn about really new gas heating! Send for a file of catalog and specification data. Throughout the nation, our dealers are at your service.

"Be Specific . . . Demand Pacific"



\*Patent applied for.

PACIFIC HEATER DIVISION

**NACO MANUFACTURING CO.**  
P. O. Box 310, Huntington Park, California



DUCT FURNACE

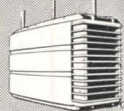

SUSPENDED UNIT



GRAVITY FURNACE

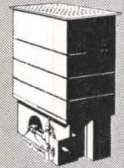

FLOOR FURNACE

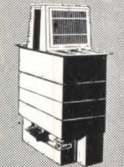

DUAL WALL FURNACE

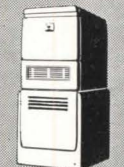

FORCED AIR FURNACE



CONSOLE HEATER



*Here's Beauty with Safe, Lasting Service in Step Treads—*

### Now— Heavy Duty Molded SAFETY

Step Treads in marbled blue-gray and tan patterns give appealing beauty with long-lasting service. . . . MELFLEX SAFETY Treads are molded  $\frac{3}{8}$  inch thick of special "frictioned" rubber compound to cover both the tread and step-edge. Approved by Underwriters Laboratories, Inc. (No. SA 833) as a SAFETY feature, this molded tread applies without requiring metal strips or screws. It stays "put", won't buckle or blister when applied simply with MELASTIC Water-Proof Cement to wood, stone, metal or composition steps. . . .

### Molded in One-Piece To Cover Approach Edge . . .

It cushions step edge as well as provides sure-gripping tread safety, wet or dry. These Treads, also available in black compound, may be applied on inside or outside steps with equal safety and service.



### MEL-ISLE Heavy Duty Ribbed Rubber Runner . . .

Compounded of special "frictioned" rubber for hard wear and slip-proof service, MEL-ISLE makes the ideal covering for aisles, runways, corridors, locker rooms. Available in black only  $\frac{1}{8}$ " and  $\frac{3}{8}$ " thick, 36" wide and cut to any specified lengths. High ribbed pattern facilitates cleaning and keeps tread surface slip-proof. MEL-ISLE Molded Mats, for entrances,  $\frac{3}{8}$ " thick and in 5 stock sizes have beveled edges to prevent tripping. Slip-Proof wet or dry. . . . Durable, Economical.

Write for Factory-Saving-Prices on any Safety Surfacing Need.

**MELFLEX**  
PRODUCTS CO.  
L. E. WARFORD, President  
410 S. Broadway, Akron 8, O.



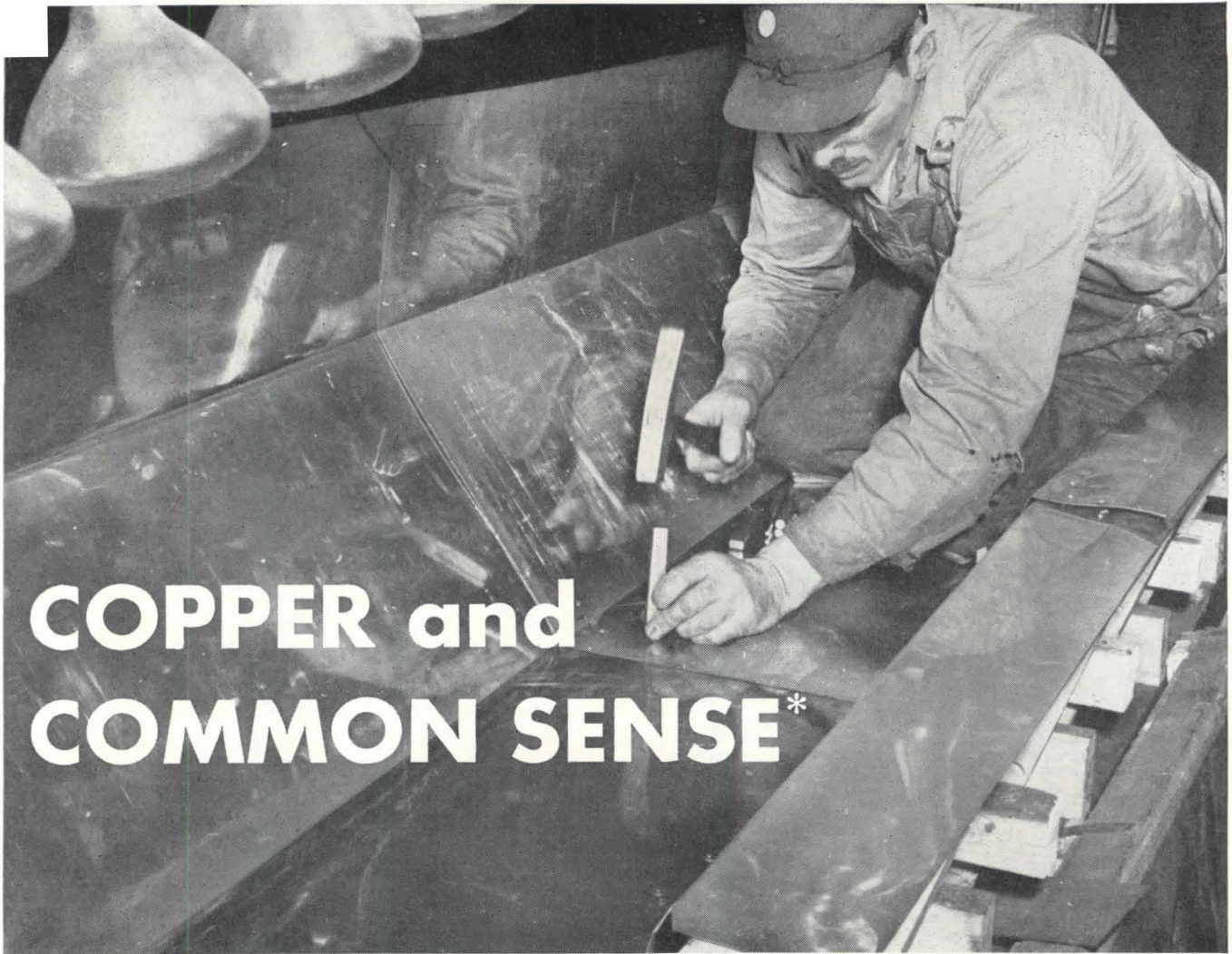

# COPPER and COMMON SENSE\*

\*See Revere Manual:  
"Research Solves Problem of Stress Failures in Sheet Copper Construction"

Photographed at Revere Research Laboratories

**QUESTION:** Where can you get data on any phase of sheet copper construction?

**ANSWER:** From the Revere Technical Advisory Service, Architectural.

IN order to help you provide the finest sheet copper construction, Revere Research takes nothing for granted. The *whole subject* is constantly under study in the Revere Research Laboratories; and important new facts are available which enable you to design or install copper gutter linings, flashings and roofs that give *extra* years of service.

An example of the thoroughness of this work is a recent investigation of the holding power of various types of nails. Revere is interested not only in seeing to it that the right specifications of copper are used, but also in every factor, large or small, that will help your jobs give lasting satisfaction.

Whenever you are faced with a problem concerning the design or installation of copper, look first to the Revere manual; and if you do not find the complete answer there, the Revere

Technical Advisory Service, Architectural, will be glad to help you. The chances are that they have already had experience with a similar problem. In any case, they'll do their best to help solve yours.

There is no charge or other obligation for this service. Simply call your Revere Distributor or the Revere office nearest to you.

## REVERE

COPPER AND BRASS INCORPORATED

*Founded by Paul Revere in 1801*

230 Park Avenue, New York 17, New York

Mills: Baltimore, Md.; Chicago, Ill.; Detroit, Mich.;

New Bedford, Mass.; Rome, N. Y.

Sales Offices in Principal Cities, Distributors Everywhere



# Pride of Ownership GOES WITH Moultile FLOORS

Visitors inspecting a newly completed or remodelled building often single out the Moultile floors for their most admiring comments. The sparkling, fresh colors, subtly interwoven with crisp, distinct veining, instantly captivate the eye. Judiciously used designs blend harmoniously with the decorative scheme. Standing or walking on quiet, foot-friendly Moultile is pleasantly restful.

Such universal admiration enhances the owner's pride in his property. It is also an additional source of satisfaction for the architect who specifies Thos. Moulding Moultile for its many other desirable properties . . . its time-defying durability, ease of installation, easy maintenance and its economical cost.

If you are not already acquainted with Moultile, write today for free samples . . . and ask for a copy of our complete catalog. THOS. MOULDING FLOOR MFG. CO., 165 W. Wacker Drive, Dept. AR-8, Chicago 1, Ill.

**THOS. MOULDING**

# Moultile

**Flexible-Reinforced  
MASTER ASPHALT TILE**

*Laid in individual squares, Moultile lends itself to functionally artistic patterns . . . like this diagonally striped floor which helps to set off the staggered island displays at Herbergers, Edina, Minn.*



● Architects and contractors are specifying more "STREAMAIRE" Convectors than ever before because of their simplicity of installation and heating efficiency. "STREAMAIRE" Convectors have been standardized in *four basic types*. You can offer smart styling plus heating comfort. Young-built convectors are packaged for protection against damage in storage and transit, plus this added time-saving feature—cartons are clearly marked for quick, positive size and type identification. Assure satisfaction—specify "STREAMAIRE" Convectors by Young. Send for free "STREAMAIRE" Catalog No. 4046 today!

## STANDARDIZED IN FOUR BASIC DESIGNS

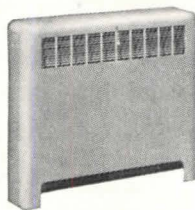

**FREE-STANDING TYPE "G"**

Saves on installation costs; ideal for remodeling or new construction.

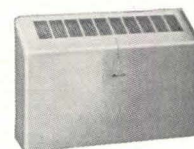

**WALL-HUNG TYPE "WS"**

Sloping top grille prevents careless blocking of air circulation.

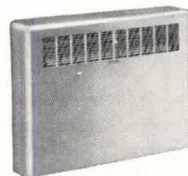

**WALL-HUNG TYPE "W"**

Off-floor installation makes routine floor cleaning easy.



**PARTIALLY-RECESSED TYPE "S"**

Special "Z" Bars permit installation before or after plastering.

# YOUNG

## HEAT TRANSFER PRODUCTS



**YOUNG RADIATOR CO.**  
Dept. 517-H, Racine, Wis., U.S.A.

Sales and Engineering Offices in all  
Principal Cities

### AUTOMOTIVE AND INDUSTRIAL PRODUCTS

Gas, gasoline, Diesel engine cooling, radiators • Jacket water coolers • Heat exchangers • Intercoolers • Condensers • Evaporating coolers • Oil coolers • Gas coolers • Atmospheric cooling and condensing units • Supercharger intercoolers • Aircraft heat transfer equipment

### HEATING, COOLING AND AIR CONDITIONING PRODUCTS

Convectors • Unit Heaters • Heating coils • Cooling coils • Evaporators • Air conditioning units •



**GOLD BOND**

# **ACOUSTIMETAL**

**THE FIREPROOF, WASHABLE  
ACOUSTICAL TILE FOR  
EXACTING SOUND  
CONTROL**



"ACOUSTIMETAL" is the last word in sound conditioning! It provides maximum noise reduction and high light reflection. It's practically indestructible, and of course, it's *fireproof* to fit new building code specifications.

"Acoustimetal" is adaptable to remodeling as well as new building. The perforated Acoustimetal Pan, containing spacer-grid and sound absorbing Acoustipad, is quickly and simply snapped into the patented T-Bars mounted on the ceiling. Ideal for use with modern troffer type lighting. The satin-smooth baked enamel finish is smart in appearance and can be washed repeatedly and repainted again and again without loss of sound absorption. The 12" x 24" pans are quickly removable, for repair

to wiring, piping, and air ducts. True, Acoustimetal costs more than ordinary inflammable sound conditioning, but the savings in maintenance more than cover the difference. For complete details, write for our new illustrated Acoustimetal folder!

**You'll build or  
remodel better with  
Gold Bond**

**NATIONAL GYPSUM COMPANY • BUFFALO 2, N. Y.**

*Over 150 Gold Bond Products including gypsum lath, plaster, lime, wallboards, gypsum sheathing, rock wool insulation, metal lath products and partition systems, wall paint and acoustical materials.*



## TERRAZZO the Lifetime Hospital Floor

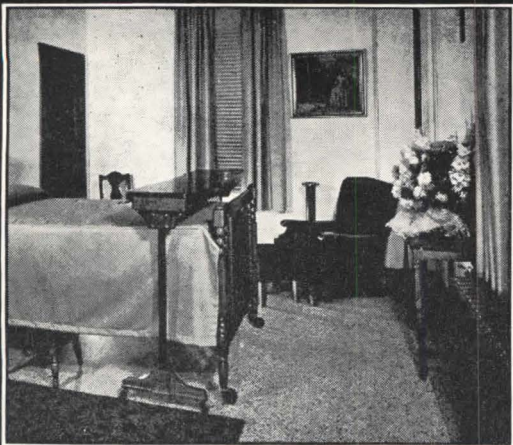

*Terrazzo*

### FOR PRIVATE ROOMS

. . . Safe . . . Sanitary

. . . Economical

In the leading Hospitals TERRAZZO floors have moved into private rooms. Here TERRAZZO does double duty. It blends with the design, decoration and furnishings — creating a neat, practical rich appearance — it saves money because it is so long lasting, resistant to wear and easy to clean.

TERRAZZO has many advantages— not only in private rooms, but in corridors, reception rooms, operating rooms and offices. It is used in hospitals extensively for base, wainscot, walls and stairways. TERRAZZO more than pays for itself by eliminating repairs and replacement costs. Easy to clean it reduces maintenance costs sharply.

#### Plan Your TERRAZZO Requirements

with this  
**FREE A. I. A. KIT**



This fact-filled handy reference kit, will show you *why* TERRAZZO is ideal for most any Hospital installation.

**THE NATIONAL TERRAZZO AND  
MOSAIC ASSOCIATION, INC.**

1420 New York Ave., N. W., Dept. R, Wash. 5, D. C.

# RUSCO

## WINDOW CONDITIONING\*



\*  
**All the benefits of storm windows**  
**All the benefits of screens**  
**All the benefits of weatherstripping**  
*in one permanently installed unit*

with nothing to change . . . nothing to store . . .  
year 'round, rainproof, draft-free, filtered-  
screen ventilation . . . patented Thermolok\*  
frame insures permanent, weatherproof fit.

Thousands upon thousands of prospective home, commercial and industrial building prospects know all about the many year 'round advantages of RUSCO ALL METAL, SELF-STORING COMBINATION SCREEN AND STORM SASH. Your recommendation will receive enthusiastic approval.

Specifications will be found in Sweets File or complete descriptive literature and specifications sent upon request.

## THE F. C. RUSSELL COMPANY

6400 AR HERMAN AVENUE • CLEVELAND 2, OHIO

"Always one step ahead  
of the weather" with  
**RUSCO**

©TFCRC  
\*T. M. REG. APP. FOR

Also manufacturers of Rusco All Metal Venetian Awnings, Thermoseal Combination Windows, Cinco Sto-a-way Windows.



# Boys Town

FATHER FLANAGAN SEES  
THE REALIZATION OF  
A THIRTY-YEAR DREAM

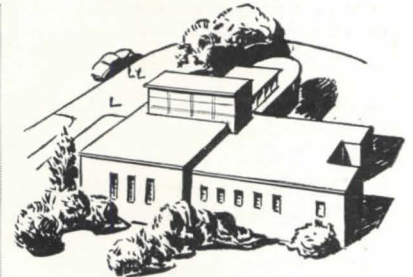
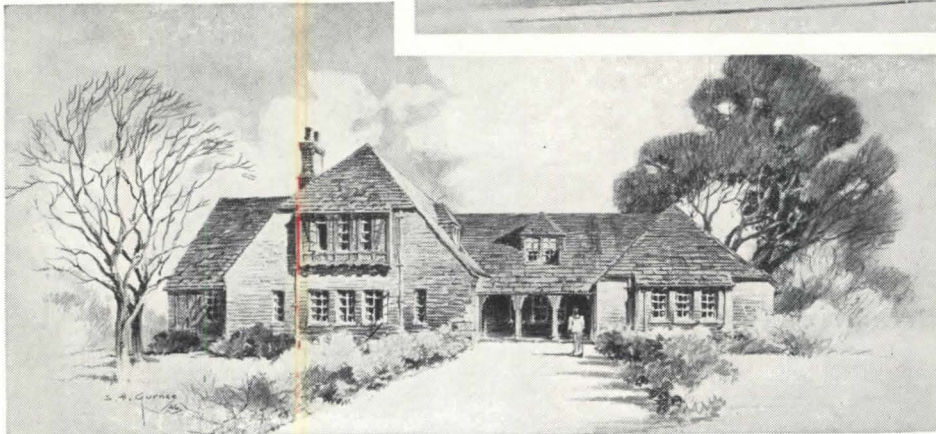
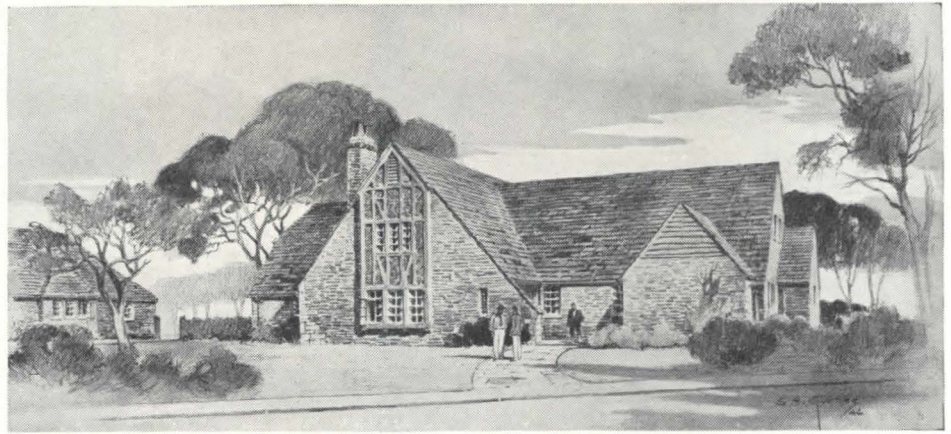

*Boys Town designs, a few of which are shown here, are the work of Leo A. Daly Co., Omaha, Nebr., architects.*

## Buildings, living quarters completely Bryant Winter Air-Conditioned



A dream that began thirty years ago with a young priest and five homeless boys is nearing reality with the construction of a three-million-dollar addition at Boys Town, ten miles from Omaha, Nebraska.

When completed, Father Flanagan's Boys Town will be able to provide accommodations

for one thousand boys, more than twice the number now being cared for. The new addition includes twenty-five cottages of the type shown in the larger illustrations above, each of which will house twenty boys of high school age; a grade school and a high school, both completely equipped with motion picture apparatus for visual education; a fully-equipped trade school; a field house, athletic fields and swimming pool; an administration building and all other facilities necessary to the proper care of destitute boys of every race and creed.

Besides these living and educational facilities, Boys Town's nine hundred acres include great farm lands and its own herds of dairy and feeder cattle, as well as

sixty acres of vegetable gardens. Here farm and dairy training are provided for boys who are so inclined.

All buildings and living quarters at Boys Town are equipped with Bryant BA-88 Winter Air Conditioners. The BA-88 is made in seven sizes with outputs up to 200,000 BTU per hour. Bryant Heater Company, 17825 St. Clair Avenue, Cleveland 10, Ohio . . . One of the Dresser Industries.

bryant  
GAS  
HEATING



LET THE PUP BE FURNACE MAN





... AND AN  
UNEQUALLED  
PAST

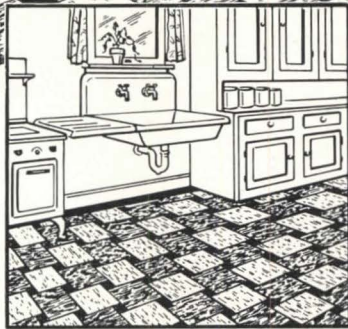

If some smart prophet would gaze into a crystal ball today and predict a brilliant future for *Wright Rubber Tile* floors, he wouldn't be guessing, he would be stating a truth proved by a quarter century of performance. Because over a period of years, *Wright* floors have proved superior to other floors in long life, low maintenance and lasting beauty. Architects and builders depend on *Wrightex* and *Wrightflor* to assure customers satisfaction.

To meet flooring requirements in modern homes, institutions and business places . . . *Wrightex*, the softer surface tile, is best where greater resiliency and quietness is preferred . . . *Wrightflor*, the harder tile, is best where heavy traffic and low maintenance costs are principal factors. Help along your own future sales success by writing us today for details.

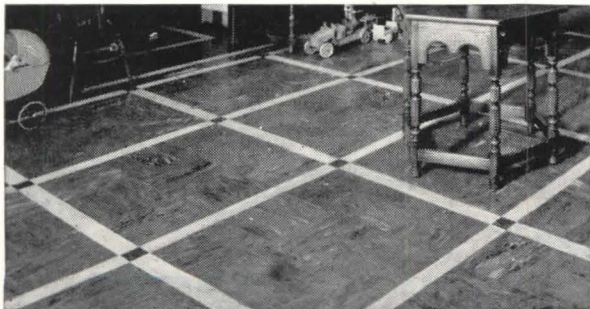

**TAYLOR MANUFACTURING COMPANY**  
Wright Rubber Products Division  
3074 W. MEINECKE AVE., MILWAUKEE 10, WIS.

**WRIGHT RUBBER TILE**  
*Flooring of Distinction.*

# H&H AUTO-MATIC DOOR SWITCHES

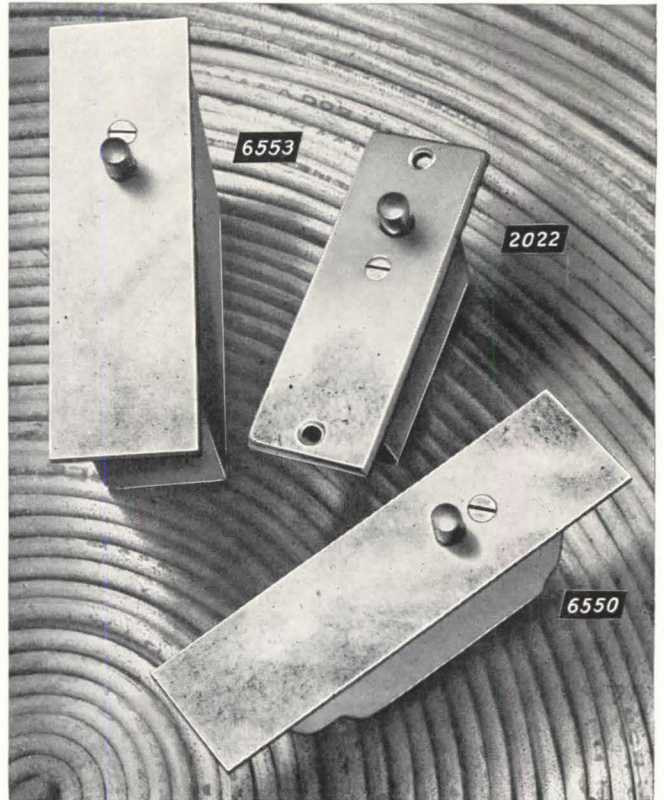

Automatically control the lights by opening and closing of doors as in closets, storage and refrigeration chambers, vaults etc. Numbers illustrated here are designed to switch on lights when door is opened; others available for lighting when door is closed. No. 6553 comes complete in an approved box with 23/32" and 1/2" knockouts and clamp for flexible metallic conduit. No. 2022 is mounted in a steel box, porcelain lined. No. 6550 is mounted in a porcelain base; fits all standard door switch boxes. Ratings: 6 Amps., 125 V.; 3 Amps., 250 V. Striker plates furnished with each switch.

Write for specification-  
data on the *complete* line.

HART & HEGEMAN DIVISION

**ARROW-HART & HEGEMAN ELECTRIC  
COMPANY, HARTFORD 6, CONN., U.S.A.**



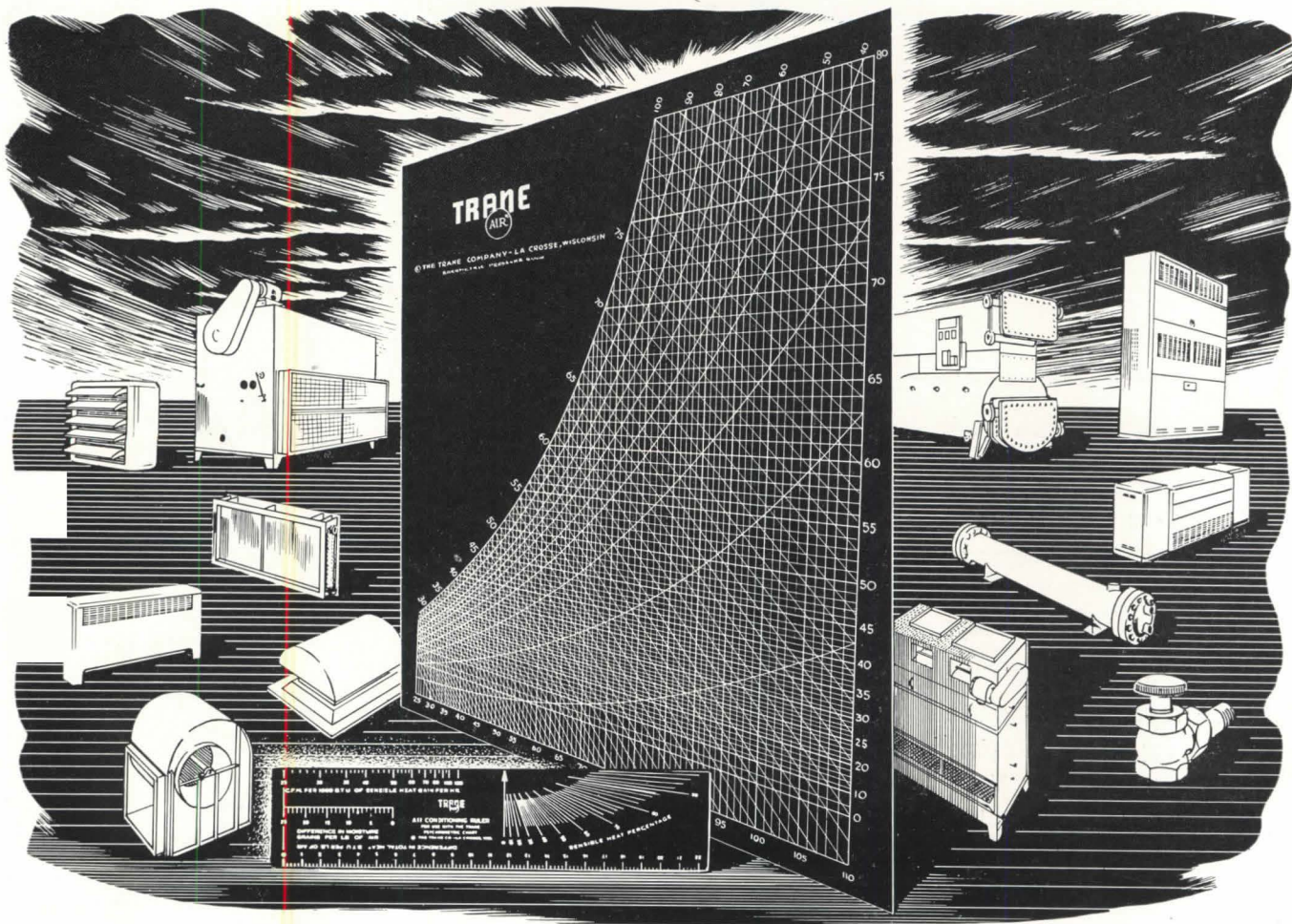

## The Straight Line to ENGINEERED AIR CONDITIONING

Achieving the desired temperature and moisture content of air are complicating factors in the design of air conditioning systems. Calculations were long and complex until Trane engineers developed the Air Conditioning Ruler to be used with the Trane Psychrometric Chart. Now professional men—and students as well—use the Ruler and Chart to solve the problems of air conditioning quickly and easily.

As the Air Conditioning Ruler and the Psychrometric Chart are made available by Trane to aid the profession, so it is with Trane products. The complete line of Trane heating and air conditioning products is designed and built by manufacturing engineers to give architects, consulting

engineers, and contractors a *single source* for the necessary elements in entire heating and air conditioning systems.

Trane heating systems and air conditioning systems—made possible by the complete line of Trane products—are designed for each application by architect, engineer, or contractor. 85 Trane field offices are ready to help them.

\* \* \*

*The Convactor-radiator—modern successor to the old-fashioned cast iron radiator—has been engineered by Trane for universal application to steam and hot water heating systems, and is being produced in quantity so you can now secure it from local distributors' stocks.*

# TRANE

Manufacturing Engineers of Equipment for  
HEATING AND AIR CONDITIONING

THE TRANE COMPANY, LA CROSSE, WISCONSIN • Also TRANE COMPANY OF CANADA, LTD., TORONTO, ONTARIO







**OLD . . . OR FOREVER NEW ?**

New materials and new methods are shaping the vigorous and timely architecture of today. And if in some cases the older ways are discarded for the new, let it always be for the sake of more livable, more durable, more beautiful results.

Lime plaster is one of those building materials that have served us through the ages, beautifully and well. It is yet finding its place wherever good buildings are constructed, looking as new as ever in this modern age, just as it has been doing in period after period of the past.

Modern technology has not produced a better way, nor even an equally good way, for finishing interior walls and ceilings. The one-piece construction of lime plaster is air-tight, fire resistant, durable. There is nothing better, nothing just as good.

Modern science did one thing however. It improved our methods of processing lime, helped us to make a product of consistently good quality. And so in northern Ohio, in the heart of the world's purest deposit of dolomitic limestone, we are making two brands of finishing lime which are always uniform, always 99½% pure.

Remember these brands. They are easily recognized by the red zig-zag stripes on the bags.

**The Ohio Hydrate & Supply Co., Woodville, Ohio**



# "Gimme that\*!"

*demands*

**Mr. H. Fitzherbert**

whose idea of a dream house calls for trouble-proof double-hung windows and modern window hardware.



And 134,445,000 magazine readers share his opinion Grand Rapids Invincible Sash Balance advertising reaches the middle and upper-crust home-building market . . . the kind of people who retain architects and engage responsible builders . . . the kind of people who want the very best.



**\*He wants the**



**The practical SPIRAL sash balance**  
 Tested in the laboratory and in thousands of homes, Grand Rapids Invincible assures smooth-working windows that never chatter. No tapes, no cables, no exposed parts — protected against corrosion. Save many hours of costly installation time . . . just drive three screws, that's all! Fits the narrowest casings. Simple adjustment without removing sash. Versatile, too — only a few standard sizes needed for 95% of your jobs — same size balance fits either upper or lower sash.

**Get complete installation data**

Write today for complete, fully-illustrated specifications and installation data . . . see how Grand Rapids Invincible simplifies and improves every double-hung window job!

## GRAND RAPIDS HARDWARE COMPANY

Grand Rapids, Michigan

Quality Leaders in Sash Hardware for 50 Years

### Grand Rapids Sash Pulleys



No. 103 face plate, cone bearing type and Nos. 175, 109, 110 sawtooth drive type sash pulleys cover 95% of all sash pulley requirements.





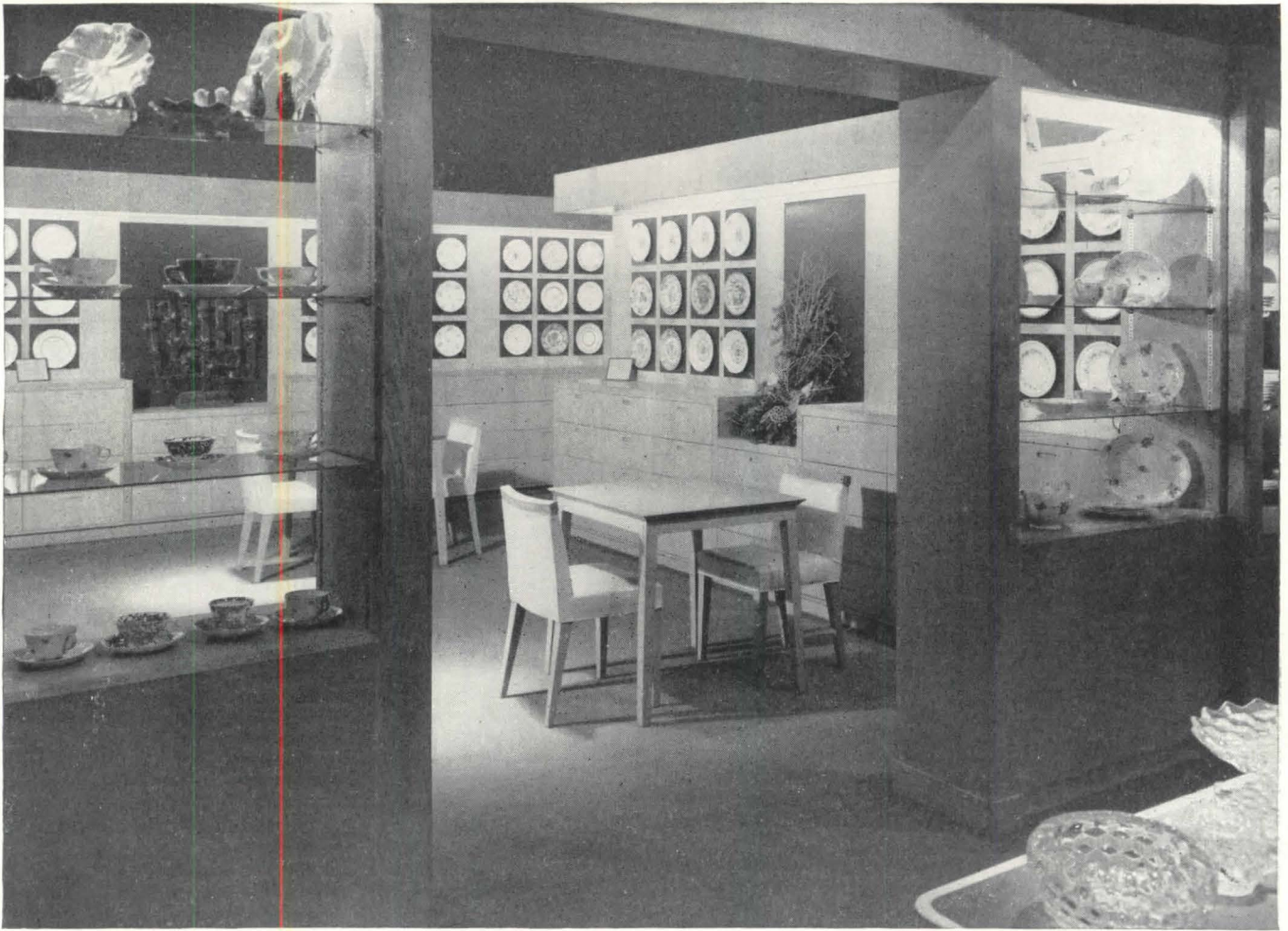

The dinnerware shop, Carson, Pirie, Scott & Co., Chicago, one of the noted wood interiors produced at Woodwork Corporation.

## WOOD ... setting for selling

*In fairness to our clients, present and future, we must remind you that Woodwork Corporation of America's services are temporarily hampered by serious shortages of materials. Contracts, therefore, can be assumed only on a basis of indefinite delivery until conditions improve.*

● Masters of merchandising know well how effectively beautiful woodwork can set the stage for selling. Architects and designers, too, know that in the hands of true craftsmen wood becomes the ideal background for accenting the beauty of products of quality. That is why it is significant that two generations of leading architects and store designers have looked to the craftsmen of this organization for faithful renditions of their plans. The results are impressive ... a long list of distinguished stores, hotels, dining rooms, office suites, clubs and churches noted for their beautiful wood interiors,

**WOODWORK CORPORATION OF AMERICA**  
1432 WEST TWENTY-FIRST STREET • CHICAGO 8, ILLINOIS



E-1



# It's SEAPORCEL for AMERICA'S CRACK TRAINS!



Getel Kahn Nastasi  
Frank J. Kahn Nastasi  
New York  
Artists and Designers

The Pennsylvania Railroad insists on the best in travel comfort and attractive surroundings for its passengers. So when Raymond Loewy Associates, consultant stylists to the Pennsylvania Railroad, suggested floral prints for the lounge cars of the postwar "Trail Blazer" and "Jeffersonian," naturally Seaporcel\* was selected.

Of course, there are many uses for which Seaporcel is ideal. It is equally effective architecturally for dramatic sweep on building facades, store fronts, interiors of public buildings, restaurants, banks, schools, hospitals and hotels.

*A multi-colored porcelain enamel mural, measuring 72 feet by 28 feet can be seen in the Union Terminal, Cleveland, Ohio. There, is an example of vast size... of picturesque ornamentation... art supreme... with no requirement ever of retouching or re-painting. It's as permanent as the walls and pilasters.*

Seaporcel is beautiful, yet inexpensive to maintain. Sparkling ceramic fused to steel at 1550° F., Seaporcel can be fabricated to any shape, form, section—finished in any shade, from purest white and pastels to deepest black. Best of all, Seaporcel is fireproof, corrosion-resistant and will withstand moderate mishandling. It always remains clean and lustrous. Specify Seaporcel on your next plans.

Write today for catalogue showing applications and current jobs

**SEAPORCEL PORCELAIN METALS, INC.**  
Formerly Porcelain Metals, Inc.  
28-02 Borden Avenue, Long Island City I, N. Y.



\*Registered U.S. Pat. Off.

Photo Courtesy of Pennsylvania R.R.

# Seaporcel

Member: Porcelain Enamel Institute, Inc.

*How to  
Size  
a*

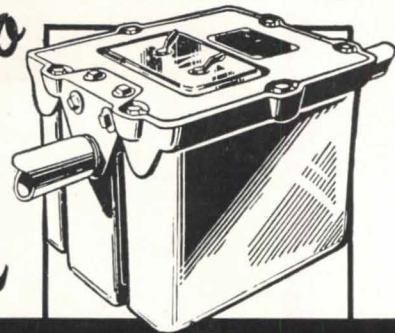

## HYDRAFILTER

for efficient grease collection

YOU DON'T BUY A GREASE TRAP BY ITS PRICE TAG! You install it according to its capacity for waste flow and grease storage. Take for example the 25-gallon-per-minute, 50 pounds grease storage, Wade HydraFilter. The grease collection efficiency of this new double-acting interceptor is guaranteed to be over 90% when its capacity is not exceeded. *NO smaller grease trap* will work satisfactorily, however, on jobs where this flow rate is encountered. Every installation must be sized according to the discharge rate of the sinks used. Here are some typical illustrations:

### RESTAURANTS AND HOTELS

A small general utility sink for meat or fish washing and rinsing, that empties at between 10 and 15 gallons per minute, requires a No. W514, 15 g.p.m., 30 lb. capacity, HydraFilter



### SCHOOLS AND COLLEGES



A large 40 gallon kitchen sink, with a 1½ inch waste line outlet, averages 23 gallons per minute discharge after using half full, so should have a W516, 25 g.p.m., 50 lb. capacity, HydraFilter.

### HOSPITALS AND INSTITUTIONS

One compartment of a scullery sink combination with 1½" outlets empties at about 20 g.p.m., but two or more compartments will not exceed 25 g.p.m., so a W516 can service the entire group.



HydraFilters in 10, 15, 20, 25 and 40 g.p.m. capacity are available for prompt delivery. Write us for correct sizing data for all types of installations.

# WADE

MANUFACTURING COMPANY

85 N. STATE ST.

ELGIN, ILLINOIS



Architects: Miller, Martin & Lewis, Birmingham, Ala.  
General Contractors: D. T. Underwood & Son, Inc., Birmingham, Ala.



## New Dormitories at University of Alabama have **OPEN-WEB JOISTS**

One of three identical dormitories now being erected on the University of Alabama campus at Tuscaloosa, this charming three-story structure will house 133 students upon completion in the fall of 1947.

Of brick construction, with slate roof and part basement, it will be 140 ft long, and will have two wings, each 80 ft in depth. Nearly 350 tons of Bethlehem Open-Web Joists are being used in the floor constructions of the three buildings.

Bethlehem Open-Web Joists have much to contribute to make any light-occupancy structure—dormitory, hospital, apartment, or home—a better

building and a sounder investment. When used with concrete floor slab and plaster ceiling Bethlehem Open-Web Joists provide an economical floor construction which prevents the spread of fire for at least two hours. What's more, they also eliminate shrinking and sagging floors and open baseboards, and minimize the passage of sound from floor to floor.

Here's another important advantage of Bethlehem Open-Web Joists: a decided saving in construction time. Not only do they permit pipes and conduits to be run through the open webs, but the joists themselves can be installed with a minimum of effort. Arriving at

the job shop-fabricated and clearly marked, the Bethlehem standard-type joist can be handled by two men. And the Longspan type of joist can be swung into place by means of a lightweight gin pole.

If you would like additional information about Bethlehem Open-Web Joists, we suggest you get in touch with the nearest Bethlehem district office. Or, if you prefer, drop a line to us at Bethlehem, Pa.

**BETHLEHEM STEEL COMPANY**  
BETHLEHEM, PA.

On the Pacific Coast Bethlehem products are sold by  
Bethlehem Pacific Coast Steel Corporation

**BETHLEHEM OPEN-WEB JOISTS**

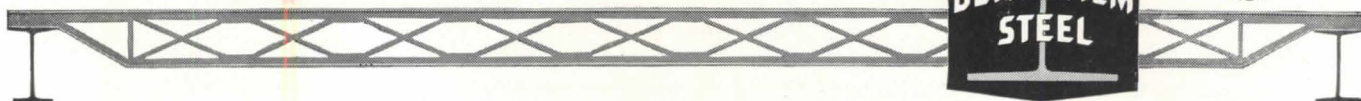



**KIMBERLY  
DRAWING PENCILS**  
CORRECTLY SUITED TO EVERY DRAWING PURPOSE

Architects, Engineers and Draftsmen like the satisfying results they achieve when using KIMBERLY Drawing Pencils. They are also discovering the beauty of color renderings done with the new

**MULTICHROME**  
COLORED DRAWING PENCILS — 50 Brilliant Colors

Multichromes in sets of 12-24-36-48.  
Kimberlys in 22 accurate degrees, 6B-9H, Extra B  
Layout Pencil, and Tracing 1-2-3-4.  
Buy them from your art supply dealer

*Makers of Fine Pencils since 1889* **General Pencil Company** 67-73 FLEET STREET, JERSEY CITY 6, N. J.

## Bowstring Roof Trusses

INCORPORATE STURDY  
MESKER STEEL BOWSTRING  
TRUSSES IN YOUR DESIGN FOR  
ANY BUILDING REQUIRING FREE  
FLOOR SPACE... YOU'LL TAKE  
PRIDE IN YOUR FINE JUDGMENT.

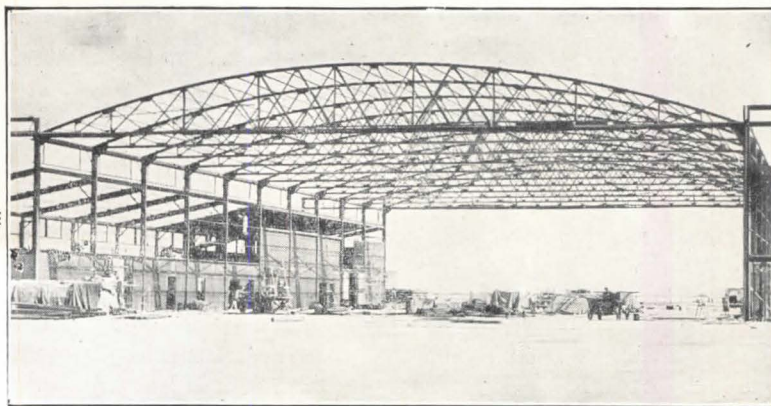

There is a Mesker Design for  
every locality... no matter where  
you are.

F R E E C A T A L O G U E U P O N R E Q U E S T

**GEO. L. MESKER STEEL CORP. • EVANSVILLE 8, IND.**

*Specify MESKER Steel on Your Next Project*





# ... leads the show in heating!

Here are your star performers for the sales seasons ahead. This newest line of National Heat Extractors is the result of more than seven years of intensive research.

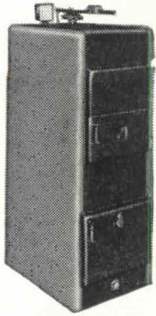

**"100" SERIES.** Smart and compact for small home installation in kitchen, basement or utility room.

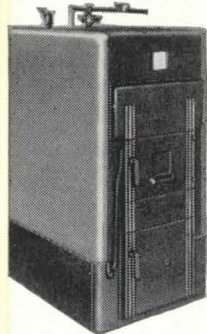

**"200" SERIES.** Big boiler performance for homes of medium size and some commercial installations.

The features your customers want most—economical heating, long efficient service, smart appearance, easy convertibility to any fuel—have been engineered into this new, sturdy generation of an already distinguished family.

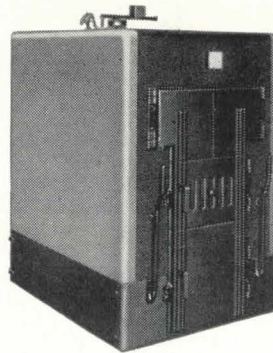

**"300" SERIES.** For larger homes, small apartments and various commercial installations where more heat is needed.

Models to fit every need from small homes to large commercial installations.

**"400" SERIES.** The "400" and "500" are designed for very large installations where plenty of heat is required to serve many purposes. Characteristic HEAT EXTRACTOR construction.

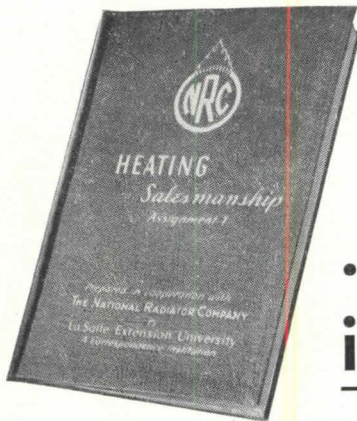
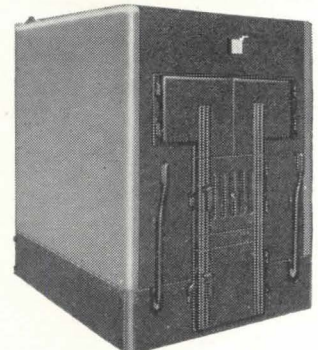

## .. shows the way in selling!

To help you make more sales faster than ever before, NRC offers you its now famous training in "Heating Salesmanship." Received enthusiastically by practical heating and plumbing men across the country, its down-to-earth sales methods are already leading thousands in your industry to

greater success. The five assignments, designed specifically for you who sell or install heating equipment, cost only \$12.50. An additional assignment for Wholesaler salesmen is only \$4.00 extra. Call your nearest NRC office or

**WRITE TO:** The National Radiator Company, 221 Central Avenue, Johnstown, Pennsylvania. Complete information will be given to you without obligation.



**The NATIONAL RADIATOR Company**  
JOHNSTOWN, PENNSYLVANIA





# Lawson LEADS AGAIN!

**I**N smart styling, distinctive beauty and top values, the No. 3000 line of Lawson Bathroom Cabinets is outstanding. Check the many important features.

- Seamless one-piece drawn steel body, rust-resistant—finished in High Lustre Baked Enamel.
- First-quality copper sealed plate glass mirror.
- Easy-to-clean, rounded inside corners.
- Square outside corners, with 7/8" return flange, make it easy to set cabinet in tile.
- Adjustable stainless steel shelf supports.
- Shock-absorbing bar-and-spring door stop.
- Removable stainless steel razor blade box.
- Full-length chromium-plated brass piano hinge.
- Bullet catch door.
- Patented "Jiffy" ratchet stainless steel mirror clips on models with frameless mirrors.

Write for Complete Catalog on  
Lawson Bathroom Cabinets and Accessories

**WORLD'S LARGEST  
BUILDERS OF  
BATHROOM CABINETS**  
THE F. H. LAWSON CO.  
802 EVANS ST.  
CINCINNATI 4, OHIO

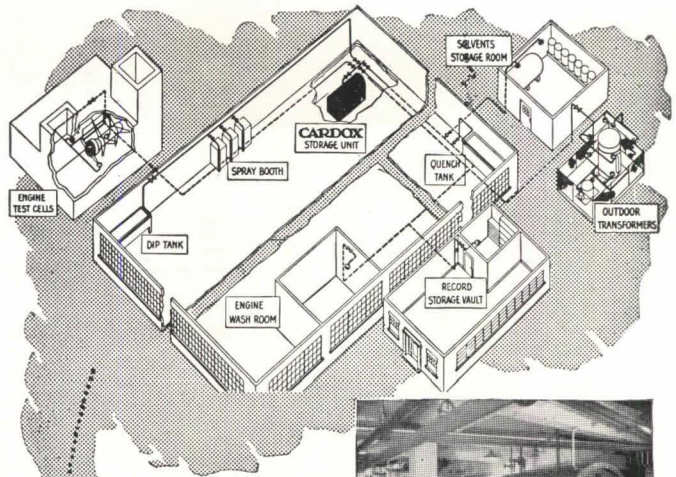

# CARDOX

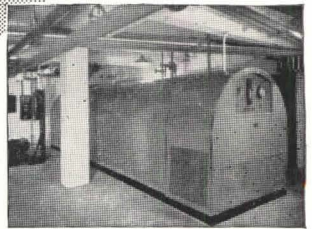

## GIVES DOUBLE PROTECTION FOR TOUGH FIRE HAZARDS

**DOUBLE**—because the Cardox method of engineered application and control makes it entirely practical to provide enough fire-killing carbon dioxide to give "double-shot" safety to the largest hazard protected, multiple shot protection to other hazards covered by the system. This *ample reserve* that means uninterrupted protection *after* fire has been extinguished is a recognized principle of sound Cardox fire engineering.

**DOUBLE**—because *mass* application of Cardox CO<sub>2</sub> in *pounds* or *tons* means less fire damage. Burning time is cut to a minimum. Non-damaging carbon dioxide cannot harm costly equipment or material in process. There is no after-fire clean-up to cause costly production delays.

Cardox Fire Extinguishing Systems use low-pressure carbon dioxide—stored at 0° F. and relatively low pressure in a single, compactly designed, centrally located Storage Unit that holds from 1/4 to 125 tons. The Cardox method of application and control and Cardox engineered equipment have broadened both the performance and protection scope of carbon dioxide—providing *all* the proved advantages of CO<sub>2</sub> extinguishment for tough fire hazards, single or multiple, large or small, indoors or out.

Why not determine for yourself whether this broadened application of carbon dioxide by Cardox Systems or mobile equipment may not be the most effective answer to the fire problems that concern you? Write for Bulletin No. 1587

**CARDOX CORPORATION**  
BELL BUILDING • CHICAGO 1, ILLINOIS  
District Offices: New York • Philadelphia • Pittsburgh • Cleveland  
Detroit • Los Angeles • San Francisco • San Diego

# CARDOX

**CO<sub>2</sub> FIRE EXTINGUISHING SYSTEMS**



# CORRUGATED TRANSITE\* ... as modern as tomorrow

\*Transite is a registered Johns-Manville trade mark



From smart shops on Main Street to gigantic "shops" of industry, Corrugated Transite is being used to streamline construction and reduce costs. Transite sheets can't rot . . . can't rust . . . can't burn

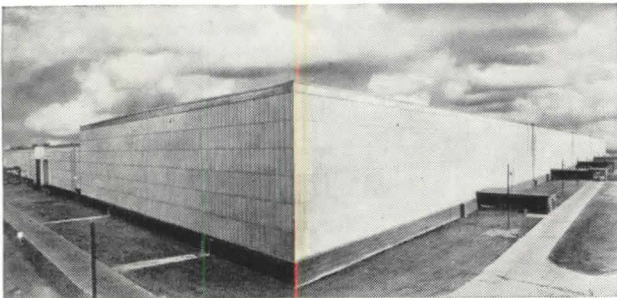

The corrugations in Transite increase the unusual strength of the asbestos-cement sheets—thus allow minimum framing. But the corrugations also serve as an important element of design in modern construction.

• The surprising news about Johns-Manville Corrugated Transite is not the fact that it is fire-proof and weatherproof . . . or that it needs no preservatives, and practically no upkeep. Those and other advantages have already become widely appreciated through the years.

But look at the striking lines of the store front above . . . and the attractive, streamlined simplicity of the industrial giant shown at left. In both cases, versatile Transite provides *attractiveness* as well as utility. Yes, architects, engineers, and builders are discover-

ing that Corrugated Transite lends itself effectively to modern design.

Use it on roofs or sidewalls . . . on both new or remodeled structures. Transite sheets are easily applied . . . cover large areas quickly because of their size . . . and can be completely salvaged when alterations are necessary.

Send for new brochure. Johns-Manville, Box 290, N. Y. 16, N. Y.

Because of unprecedented demand, there may be times when we cannot make immediate delivery. Please anticipate your needs.



EASY TO BOLT TO STEEL

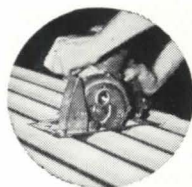

EASY TO SAW



EASY TO DRILL

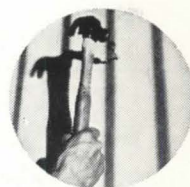

EASY TO NAIL TO WOOD

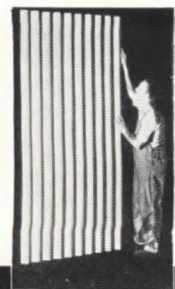

**Johns-Manville**

*Asbestos*

**CORRUGATED TRANSITE**



# PRESTILE

*"Its Plastic Beauty is Baked In"*



## Eleven Million PresTile "Salesmen"!

**T**O MILLIONS of homes all over America — 11,674,703, to be exact — PresTile brings its message of beautiful, practical walls, quickly and inexpensively set up.

PresTile advertising appears in *Better Homes & Gardens*, *American Home*, *House & Garden* and *Small Homes Guide*. All of it is designed to make prospective home builders and remodelers familiar with PresTile advantages.

This means ready acceptance when you specify this tileboard of recognized quality!

*To our Dealers: Much as we'd like to hurry up production of PresTile to meet the overwhelming demand, we will not skimp on quality and care needed to produce a better tileboard. However little you may receive, be assured it's the best that can be made.*

**Prestile Manufacturing Company**  
2860 Lincoln Avenue • Chicago 13, Illinois



# Prefabrication in Building

by RICHARD SHEPPARD, F.R.I.B.A.

• This book shows how architects and builders can make prefabrication work for them.

• In England, where nearly every house was damaged by German bombs, the architects and builders are not trying to turn out finished houses on conveyor belts, but neither are they trying to outlaw prefabrication. Their answer is *partial prefabrication*, and the book *PREFABRICATION IN BUILDING* describes—with scores of specific cases and more than 150 illustrations—the systems they have studied and used.

• In this book, Mr. Sheppard examines the development of prefabrication in England, America and elsewhere, and analyzes in detail the various systems—some commercial and some merely experimental—which have so far been used. He considers the important relationship between prefabrication and the industrial and economic background in various countries (American plywood houses would be less practical in England, where timber is scarce) and outlines the changes that prefabrication is bringing about in building procedure.

• No builder or architect who is seeking ways to economize on house construction can afford to miss this valuable guide—148 pages printed in large clear type on heavy coated paper, well indexed and illustrated with 163 excellent photographs and diagrams. The supply (just imported from England) is painfully restricted. Orders accepted temporarily at \$5.50 per copy.

• To get your copy of *PREFABRICATION IN BUILDING* use the coupon below. Then attach your check or money order for \$5.50 and mail to Architectural Record Book Department (sole American distributor), 119 West 40th Street, New York 18, N. Y.

Book Department, *Architectural Record*  
119 West 40th Street, New York 18, N. Y.

I enclose \$..... Send me..... copy(s) of "PREFABRICATION IN BUILDING," by Richard Sheppard at \$5.50 per copy. (Add 2% Sales Tax for New York City delivery — \$5.61 in all)

Name.....

Address.....

City..... Zone..... State.....





A survey taken among workers in 400 manufacturing plants showed that good washrooms are one of the four most important factors in good working conditions.

## "There's no excuse for a sloppy washroom!"

**RALPH:** "You can tell a lot about a company by the way they look after the employees' washrooms. Our management here sure knows how much we appreciate a nice place to clean up in."

**WYNN:** "You bet—a good clean washroom—equipped right—doesn't cost a lot of money but it surely makes a big difference!"

**E**Mployees judge a company a great deal by its washrooms. In a survey of men and women workers at more than 400 plants, they named these factors as the ones they considered most important in good working conditions: *good washrooms, adequate lighting, safety devices and proper ventilation.*

Besides helping morale, sanitary, well-equipped washrooms, with plenty of soap, hot water and good quality individual tissue towels, help reduce the number of absences due to colds and their complications. For they encourage frequent and thorough washing that helps prevent germs from spreading.

Haven't you yourself been irritated by a neglected washroom? Then check up . . . make sure your washrooms are "Health Zones," not "Germ Exchanges"—"morale-boosters," not "temper-testers."

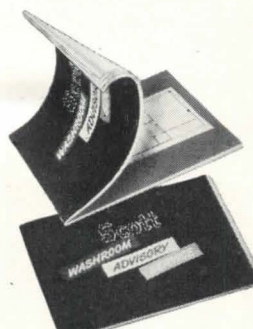

### NEW FREE BOOKLET Helps plan better washrooms

Send for your free copy—illustrated with floor plans and details—issued by Scott "Washroom Advisory Service." A partial list of contents: Planning for Personal Services; Controlled Traffic Flow; Plant Locker and Washrooms; School Washrooms; Recreation Rooms; Fixture Locations; etc. Write Washroom Advisory Service, Dept. D, Scott Paper Co., Chester, Pa.



**SCOTTISSUE TOWELS**

**Largest selling tissue towels in America!**

Trade Marks "ScotTissue," "Washroom Advisory Service," "Duralose" Reg. U. S. Pat. Off.



*Use this  
Timely Catalogue!*



**80** Dimensionally accurate aluminum moulding shapes, expertly designed in matching groups to fit any installation, illustrated in the new full-color CHROMTRIM Catalogue No. 2. Also features many unique installation possibilities.

Follow the new trend—give home-making women the gleaming beauty—the modern neatness—the easy maintenance they want in the homes you plan to build (or modernize). Specify CHROMTRIM for kitchens, bathrooms, attics, etc.

**IMMEDIATE DELIVERY**

Nationally distributed. See insert in Sweet's File (Architectural Edition).

**R. D. WERNER CO., Inc.**

Manufacturers of Metal and Plastic Products

295 FIFTH AVENUE • NEW YORK 16, N. Y.

Factories: New York City—Greenville, Pa.

**EMPLOYMENT OPPORTUNITIES AVAILABLE**

**WANTED IMMEDIATELY**, experienced architectural designer, two draftsmen on working drawings. An opportunity for qualified men. Give complete history in first letter. Box 246, ARCHITECTURAL RECORD, 119 W. 40th St., New York 18.

**WANTED**—Several experienced Architectural Draftsmen, one Architectural Engineer, one Specification Writer. Work consists of hospitals, schools, commercial and residential. 44 hour week. State education, experience, age and salary expected. Otis and Grimes, 312 Tyler Bldg., Louisville 2, Ky.

**SENIOR DRAFTSMAN**—graduate, with ten years' drafting experience consisting of varied architectural and construction background including estimating. Worked on all types of building. Seeking position with established architectural or construction firm in Florida. Wishes to make permanent home there. Overseas veteran. Box 248, ARCHITECTURAL RECORD, 119 W. 40th St., New York 18.

**WANTED:** Designer-delineator with imagination, several experienced draftsmen who have not learned too well how things were done yesterday, structural engineer with experience in concrete work. Firm doing general architectural, interior and industrial design; neighborhood planning, and large scale housing. Good pay, and good working conditions, and perpetual sunshine. (Well, almost perpetual.) Write all pertinent facts to: William and Sylvia Wilde, Design Consultants, 415 East Fifth Street, Tucson, Arizona.

**DRAUGHTSMAN WANTED:** Want man with broad general experience, capable of developing complete working drawings from preliminary sketch, design ability desirable. Work varies. State age, experience, education, salary expected and when available. Send recent photograph. Atlee B. and Rob't M. Ayres, 3002 Transit Tower, San Antonio, Texas.

**WE ARE VERY MUCH INTERESTED** in obtaining a man experienced in architectural drafting and design. Excellent opportunity for a permanent position and future advancement. Write advising experience, starting salary, etc. to Joseph & Joseph, 202 Speed Building, Louisville, Kentucky.

**SALES REPRESENTATION** of steel products, steel-kitchens, steel furniture and plastic material for home construction, commercial and industrial buildings wanted for Pacific Northwest by Engineering draftsman with broad technical, commercial and artistic knowledge, 15 years' private experience, 3 years with Ind. and Res. Div. of U. S. Gov. Dep. Box 250, ARCHITECTURAL RECORD, 119 W. 40th St., New York 18.

**MATURE WOMAN**, June 1947 graduate Approved landscape school, experienced secretary, seeks position where her horticultural and business training, and ability to get things done, will command good salary. Box 252, ARCHITECTURAL RECORD, 119 W. 40th St., New York 18.

**ARCHITECTS**, Designers and experienced Draftsmen needed on A and E contract on Guam. Apply giving resume of qualifications and experience to Pacific Islands Engineers, Second Floor, Ferry Building, San Francisco 11, California.



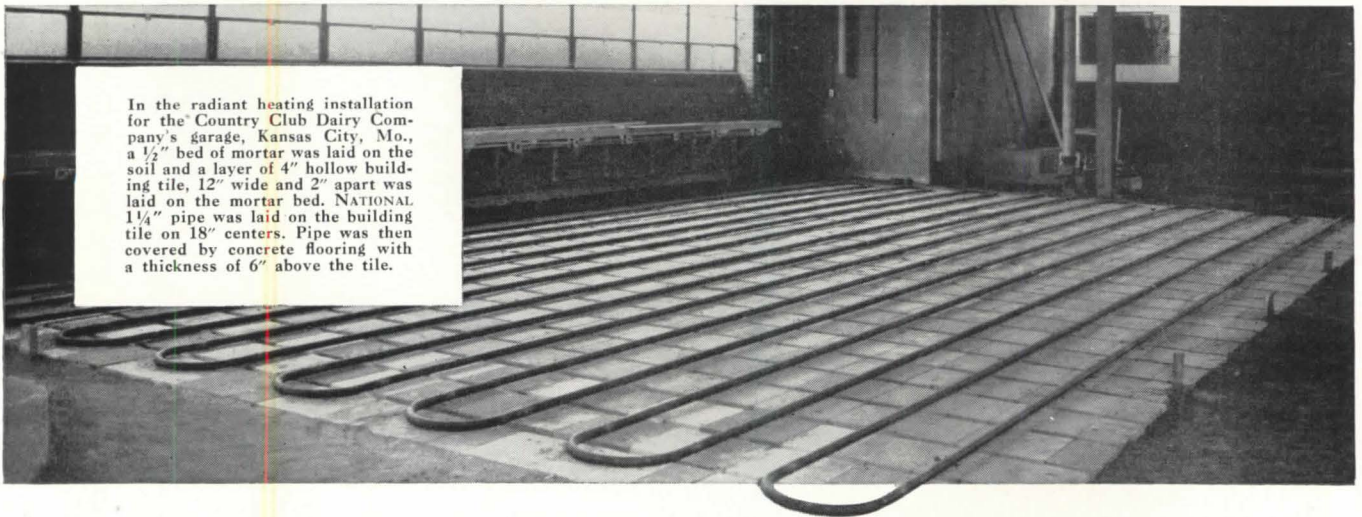
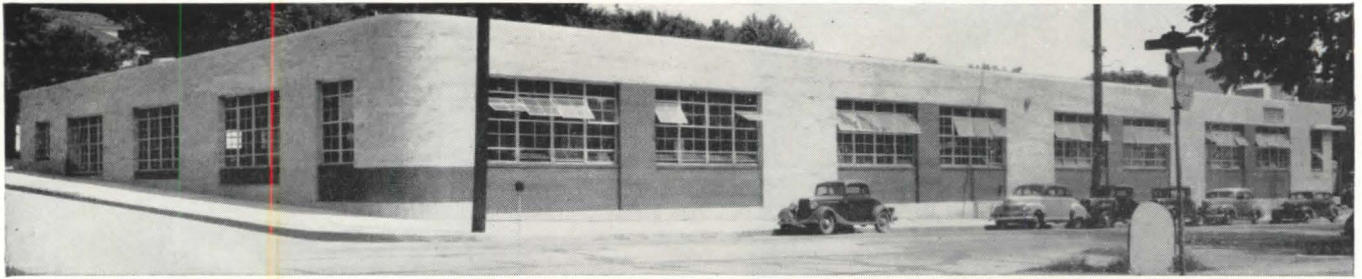

In the radiant heating installation for the Country Club Dairy Company's garage, Kansas City, Mo., a 1/2" bed of mortar was laid on the soil and a layer of 4" hollow building tile, 12" wide and 2" apart was laid on the mortar bed. NATIONAL 1 1/4" pipe was laid on the building tile on 18" centers. Pipe was then covered by concrete flooring with a thickness of 6" above the tile.

## Planning a radiant heating installation?

... make sure the pipe is **NATIONAL**

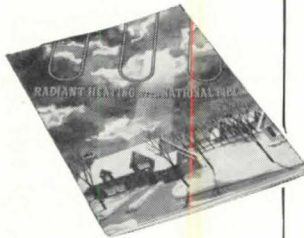

This 48-page book brings you an easy to understand story on radiant heating and gives you practical information as a basis for planning and installing an efficient pipe system. It will answer many questions about radiant heating that you may have. For your free copy address: National Tube Company, Frick Building, Pittsburgh, Pa.

**C**OLD floors, so detrimental to garage personnel, have been successfully eliminated in this Missouri dairy garage by radiant heating. It has also eliminated hot and cold temperature zones . . . minimized the chilling caused by door openings . . . provided a larger working area.

Steel pipe is ideal for radiant heating installations just as it is ideal for other hot water or steam heating systems. It expands at the same rate as concrete and plaster; it is easy to weld, easy to bend, and, with its maximum of advantages, costs less.

NATIONAL, the leader in steel pipe

for many years, offers the additional advantages of the Scale Free and Spellerizing Processes. These processes mean that the pipe interior is clean, smooth, free from mill scale, with minimum frictional resistance. They also mean superior corrosion resistance, and increased weld strength through extra rolling.

For detailed information on the use of NATIONAL Pipe in radiant heating installations, write for Bulletin — "Radiant Heating with NATIONAL Pipe." Address National Tube Company, Frick Building, Pittsburgh, Pennsylvania.



## NATIONAL TUBE COMPANY

PITTSBURGH, PA.

Columbia Steel Company, San Francisco, *Pacific Coast Distributors*  
United States Steel Export Company, New York

**UNITED STATES STEEL**





## THE FIRESTONE MEMORIAL LIBRARY AT PRINCETON

Jamestown Metal Corporation will furnish the hollow metal doors and frames in this beautiful \$4,000,000 Gothic style structure.

Main Factories and Offices of Jamestown Metal Corp.

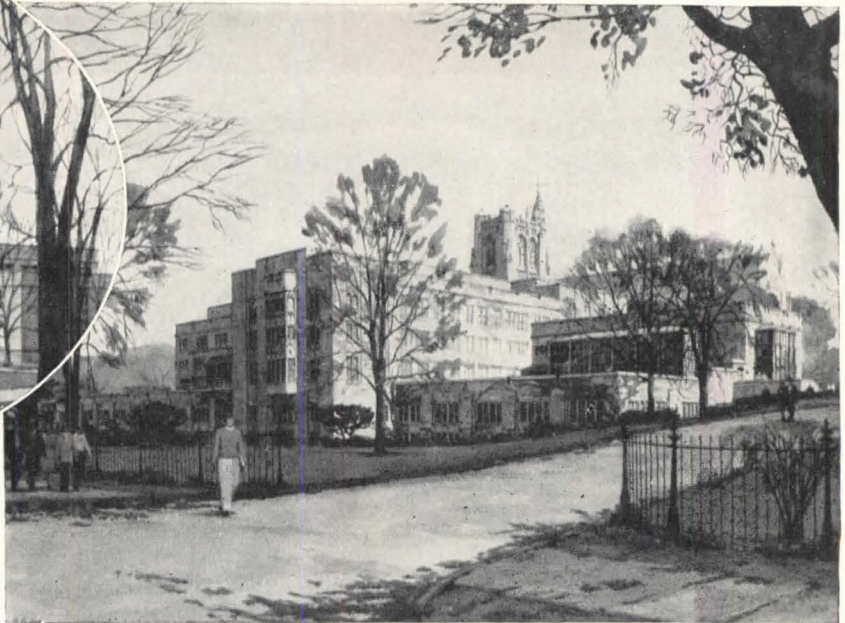

Robert B. O'Connor and Walter H. Kilham, Jr., Architects, New York City  
Turner Construction Co., Philadelphia, Pa., General Contractors



*Jamestown Metal Corporation*  
104 Blackstone Avenue Jamestown, N. Y.

As specialists in the fabrication of bronze, aluminum, steel and stainless steel, we offer our services wherever hollow metal doors, interior trim, elevator enclosures, office partitions, cold rolled mouldings and metal specialties are required.

*Available Now!*

**CHENEY FLASHING**  
*3-Way Bond*  
16 OZ. COPPER

**CHENEY FLASHING REGLET**  
16 OZ. COPPER

**CHENEY FLASHING** is again being made by the original inventor who pioneered the art of thru-wall flashing eighteen years ago.

No thru-wall flashing can operate successfully unless it has the two very important features that are found in **CHENEY FLASHING**—proven weep-hole drainage and the three-way bond, vertical as well as longitudinal and lateral.

Remember, the inferior two-way flashings, crimped copper and membranes, have neither the vertical bond nor do they drain moisture from the wall fast enough. Furthermore, their first cost advantage has disappeared because today Cheney Flashing is no longer a specialty—it's a standard commodity.

WRITE FOR DESCRIPTIVE FOLDER Dept. R

**CHENEY INDUSTRIES, Trenton, N. J.**

it's permanent

it resists corrosion

it resists heat, flame

**...it's OKOBESTOS**

"The cable with the asbestos suit" is equally at home in hot spots or wherever you find corrosive fumes, chemicals, oil and solvents.

Here's the layer-by-layer story of this mechanically strong cable: (1) Felted asbestos, impregnated with heat- and moisture-resisting compound applied directly over conductor, (2) Varnished cambric in a number of wrappings to provide high dielectric strength, (3) Felted asbestos to form a flame- and heat-resistant barrier, (4) Asbestos braid, impregnated with a black moisture-resisting compound to form a protective coating.

Bulletin OK 2061 describes the many designs of Okobestos cables available for specific needs. The Okonite Company, Passaic, N. J.

**OKONITE** OKONITE SINCE 1878

insulated wires and cables

505Q





**Plan for SAFETY and  
EFFICIENCY in the  
ARTERIES of the building**



Every architect, building manager, realtor or home owner knows that reliable piping for plumbing and heating is the most important thing in the building. To use out-moded, rustable pipe with its old-fashioned threaded fittings to supply modern fixtures and radiators is as impracticable as it is inconsistent.

STREAMLINE Copper Pipe and Solder Fittings that cannot rust or clog is the ultra-modern piping system that bridges the gap between out-moded and modern piping lines. It is the permanently reliable conducting system that insures efficient service from up-to-the-minute fixtures and radiating units, year in and year out. With the possible exception of extremely abnormal water conditions, STREAMLINE will out-last the building in which it is installed. There will be no future repair bills.

A STREAMLINE Copper plumbing or heating piping system is the most practical to install. It combines reasonable cost with long life and efficient service. Rustable piping may afford satisfactory service for the first few years—then expense and trouble commence. Install a STREAMLINE Copper system for the postwar home or building. It will be just as good tomorrow and all the succeeding tomorrows as long as the building stands.

**STREAMLINE**  
PIPE AND FITTINGS DIVISION  
**MUELLER BRASS CO.**  
PORT HURON, MICHIGAN





*The*  
**"BUBBLING BROOK"**  
*was never like this*  
**SANITARY · DEPENDABLE**  
**HAWS**  
**ELECTRIC**  
**WATER COOLER**

**To some**, the symbol of perfectly clear, deliciously cold water may still be the old "bubbling brook". To others, those concerned with planning for the efficiency, appearance and comfort of businesses, and for hospitals, public buildings and hotels, the HAWS Electric Water Cooler is the symbol of refreshment in the form of sanitary, cold water at instant command. The stainless steel top and metal cabinet create a cooler that is smart and distinctive. Specify . . .

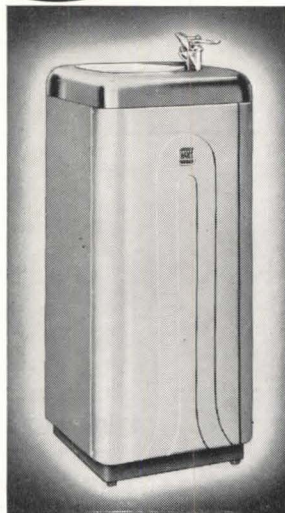

**HAWS**  
**ELECTRIC WATER COOLERS**

**HAWS DRINKING FAUCET CO.**  
 1808 HARMON STREET (SINCE 1909) BERKELEY 3, CALIFORNIA  
 Agents and Sales Representatives in All Principal Cities

**NEW!**

# OZALID STREAMLINER

- Reproduces architectural drawings in 25 seconds—also anything typed or printed on translucent paper.
- Moderately priced—designed for architects who want these extra values at no extra cost.



**Efficiency.** You get positive (not negative) prints direct from your tracings, which can be up to 42" wide, any length.

**Economy.** 8½ x 11-inch reproductions cost only one cent. Ozalid Streamliner soon pays for itself in day-to-day savings.

**Versatility.** Make 16 different types of Ozalid prints—each in the same manner, in seconds.

**Simplicity.** Anyone can feed originals and Ozalid sensitized material into Streamliner.

**Compactness.** Only 11 square feet of floor space is required.

Write today for *free* booklet No. 302 containing 16 types of Ozalid prints.

## OZALID

Division of  
 General Aniline and Film Corp.  
 Johnson City, New York

Ozalid in Canada  
 Hughes Owens Co., Ltd., Montreal

# Eye-light

**YOUR MERCHANDISE**

only 5" above plaster

36° off vertical

360° turn

Cat. No. 351, semi-recessed eyeball. \$36  
 (150 watt reflector bulb)

CENTURY Lighting Equipment is ENGINEERED Lighting Equipment

**CENTURY LIGHTING, INC.**  
 419 West 55th Street, New York · 626 N. Robertson Blvd, Los Angeles

# DELANY FLUSH VALVES



THE SIMPLEST, MOST EFFICIENT, AND EASIEST TO MAINTAIN FLUSHMETER ASSEMBLY—with full protection against back-syphonage and resulting water contamination.

Illustrating DELANY FLUSH BOY and No. 50 VACUUM BREAKER

write for catalog

SINCE 1879  
**Coyne & Delany Co.**  
 BROOKLYN N.Y.





# Now - Prompt delivery on Truscon "O-T"

## OPEN TRUSS STEEL JOISTS!

Truscon Open Truss Steel Joists are again available for your use. Their outstanding features of adaptability, economy, fire-resistance, safety and permanence can once more be incorporated into your building plans to provide maximum value in building construction. Contact your nearest Truscon representative for cooperation in completing your building plans now.

### ● FIRE-RESISTANT

Open Truss Steel Joist Construction is built entirely of incombustible materials. The reinforced concrete slab and metal lath ceiling are fire resistant materials and have proved their worth under the most severe conditions.

### ● VERMIN-RESISTANT

All members of the Truscon "O-T" Open Truss Steel Joist are steel and impregnable to the attacks of insects.

### ● ECONOMICAL

Light weight effects savings in supporting framework and foundations. Speedily erected. Lowers insurance cost and maintenance expense.

### ● ALL-WEATHER BUILDING

Construction is carried on as readily in winter as in summer. Not wholly dependent upon the setting of cement, which is seriously retarded by cold weather.

### ● SOUND-RESISTANT

The greatly increased use of Truscon "O-T" Open Truss Steel Joist Construction in larger and more expensive types of buildings and its acceptance by Architects and Engineers in all parts of the country prove that this construction fully meets the essentials of soundproofness.

### ● PIPES AND CONDUIT

The open web of the joists permits the passage of pipes and electric conduits, within the depth of the floor, thereby making such installations very economical.

### ● RADIANT HEATING

The open web of these joists will permit unobstructed flow of air current in any direction and this feature is of important consideration when planning a radiant heating system.

### ● LIGHT WEIGHT

Scientific design and welded construction permit great strength without excessive weight. Easily handled and rapidly erected.

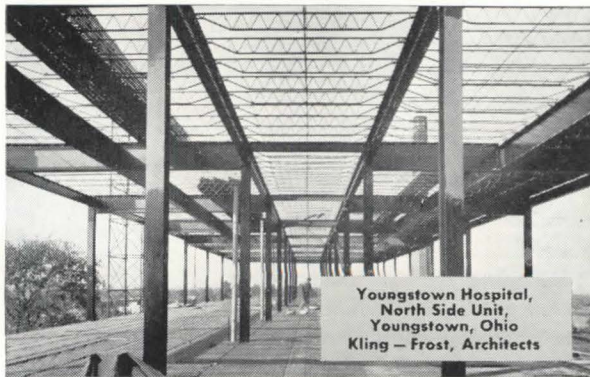
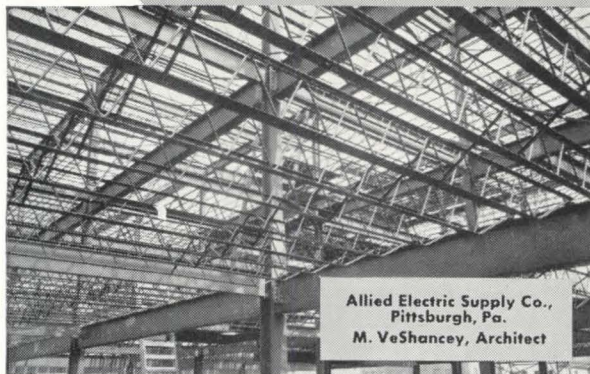

## TRUSCON STEEL COMPANY

YOUNGSTOWN 1, OHIO • Subsidiary of Republic Steel Corporation

Manufacturers of a Complete Line of Steel Windows and Mechanical Operators... Steel Joists... Metal Lath... Steeldeck Roofs... Reinforcing Steel... Industrial and Hangar Steel Doors... Bank Vault Reinforcing... Radio Towers... Bridge Floors.



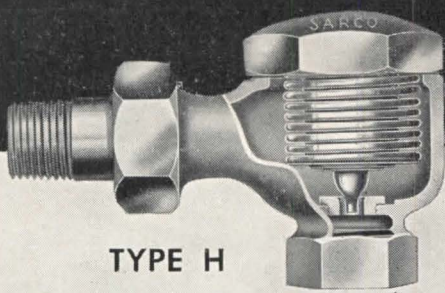

TYPE H

## One in a Million

A good radiator trap removes air and condensate from radiators rapidly and without noise or fuss, day after day—for the life of the system, and with negligible replacement cost.

Sarco has been building such quality heating specialties for nearly thirty years. For all that time, an outstanding and exclusive feature has been the Sarco heavy-wall bellows, drawn from flat blanks in our own plant, and helically corrugated.

It costs us more, but we are amply compensated by customer satisfaction resulting from trouble-free service and unusually long life. Ask for Catalog No. 160.

**SARCO** SARCO COMPANY, INC.  
475 Fifth Avenue, New York 17, N. Y.  
SAVES STEAM SARCO CANADA, LTD., 85 Richmond St. W., TORONTO, ONT.

184

"I Specify SUPRO LUX  
It's the Better Baked  
Fluorescent Glass Tubing."



Satisfied users have recommended SUPRO LUX Baked Fluorescent Glass TUBING for more than 12 years. Today Architects, too, recognize SUPRO LUX as *tops* for superior fluorescent lighting performance. SUPRO LUX research—workmanship—rigid inspection—have created the Baked Fluorescent Glass *they specify* for all types of Neon Signs and Cold Cathode Lighting.

### Specify SUPRO LUX

for years, the choice of the country's leading sign and lighting manufacturers.

- Controlled high temperature baking
- 12% to 15% Brighter color
- Economical, trouble-free use
- Precision coating
- No color variation
- Guaranteed satisfaction

**A SPECIAL SERVICE**  
SUPRO LUX is equipped to assist in the preparation of lighting specifications. Inquire for complete information.

**SUPRO LUX** MANUFACTURING CO., INC.  
127 West 17th St. • New York 11, N. Y.

**STOP** that *WATER*  
with FORMULA # 640

## A Clear Liquid Waterproofing for Old or New Construction

**PENETRATES** deeply—one inch or more—is not a surface treatment. Brush, spray, or float on stone, cast stone, concrete, mortar, stucco, tile, brick, plaster, wood, wall board—any absorbent material.

**WATERPROOFS**, preserves, prevents dusting of floors, surface dirt washes away in rain.

**FORMULA No. 640** is a balanced formula of seven different waxes and resins in a hydrocarbon solvent.

**ACID-ALKALI proof**—does not oxidize, unchanged by temperature.

**PERFORMANCE**—It is our opinion it will last as long as the concrete, mortar, stucco, etc., lasts.

**OIL PAINT** saponifies on cement unless sealed first with Formula No. 640.

**APPLY** to either side: **The pressure side, or opposite side**—it is equally effective.

**HYDROSTATIC PRESSURE**—A 20 foot head has been held by Formula No. 640.

### CUTS WATERPROOFING COSTS

because it applies three times as fast as paint, requires no special technique. No preparation—comes ready to apply. Eliminates necessity of furring. Concrete floors and walls need no membraning.

**KEEPS IN ALL CLIMATES** ● **HARMLESS TO USE**  
**GOOD COVERAGE** ● **MODERATE PRICE**

WRITE OUR ENGINEERING DEPARTMENT for office test kit, technical data, or regarding any special problem.  
J. Wilbur Haynes, Engineer

**OTHER PRODUCTS:** Formula No. 640 Toxic, combines waterproofing with termitic and fungus protection; cement hardener; cement paint; floor mastic; roof coatings, etc.

**HAYNES PRODUCTS CO.**

4007 FARNAM STREET ● OMAHA 3, NEBRASKA



## U. S. MAIL CHUTES & BOXES

Auxiliary Mail Boxes to accommodate large quantities of letters tied in bundles, and envelopes too large for the Chute are now recommended by the Post Office Department.

*Catalog in Sweets*

ESTABLISHED 1883

**Cutler Mail Chute Co**

ROCHESTER 7, N. Y.



**“Welding gives greater design freedom, saves steel in fabricating built-up members...”**

**T. R. Mullen, President,  
LEHIGH STRUCTURAL STEEL COMPANY**

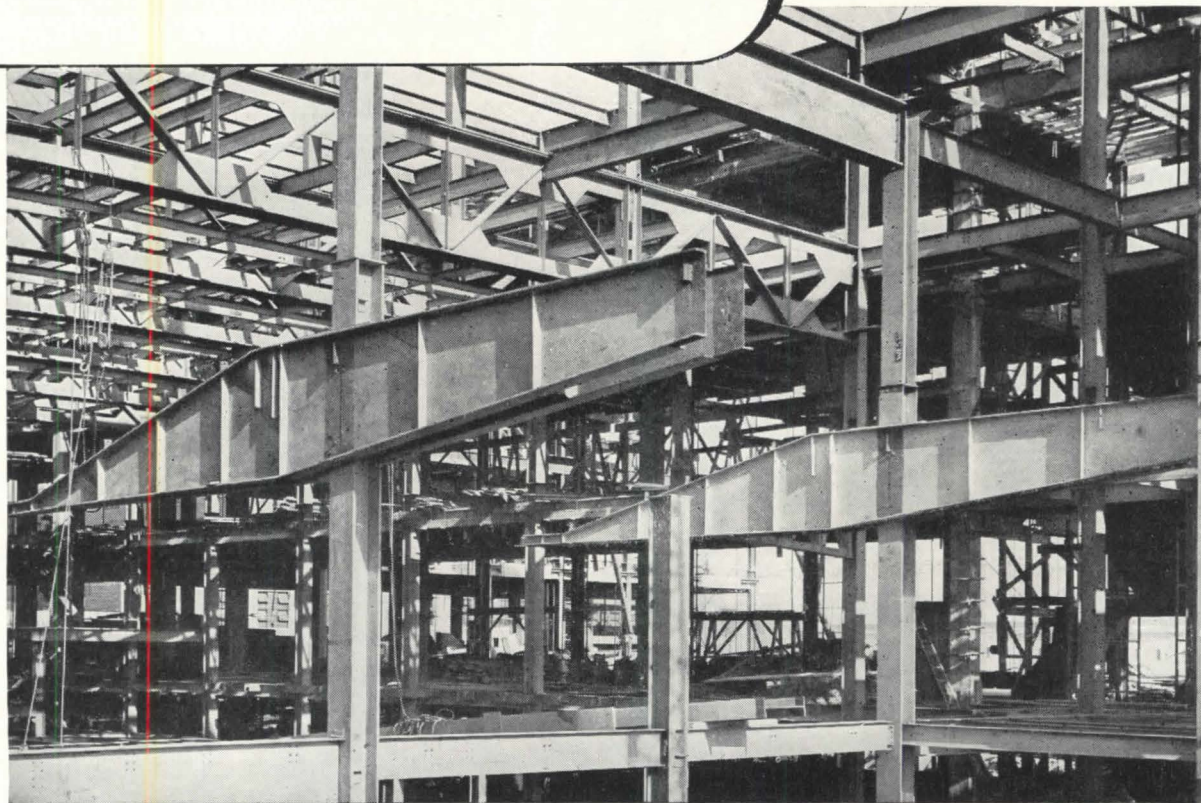

In full, Mr. Mullen stated, *“Welded construction provides greater freedom in architectural and structural design. It saves steel in fabricating built-up members — and, also, results in better appearance of exposed steel work, due to smoother surfaces and outlines.”*

Other practical reasons for using arc welding in construction work include: its quietness, the ease with which alterations and additions can be made to existing structures, and a saving of steel in structural connections.

Why not specify or recommend this modern

construction process — a process that affords unquestionable strength and enduring safety — at a saving. Today, efficient application is practical anywhere, thanks to the greatly increased number of skilled war-trained welders.

For more information about this time-proved construction technique, and how it will bring savings on your next job, write to Dept. AR-7108, Air Reduction, 60 E. 42nd St., New York 17, N. Y. In Texas: Magnolia Airco Gas Products Company, Houston 1, Texas.



**AIR REDUCTION**

*Offices in All Principal Cities*

HEADQUARTERS FOR OXYGEN, ACETYLENE AND OTHER GASES...CARBIDE...GAS WELDING AND CUTTING APPARATUS AND SUPPLIES...ARC WELDERS, ELECTRODES AND ACCESSORIES



# For Low Cost Insurance



--against  
the danger  
of scalding water

In shower baths and  
wash fountains

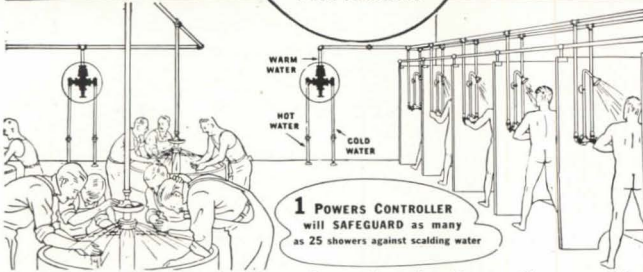

Use Powers Thermostatic Water Controllers for Group Showers, Wash Fountains, Hot Water Line Control and Industrial Processes. Capacities up to 2,650 g.p.m. Write for Circular 3017. THE POWERS REGULATOR COMPANY, 2752 Greenview Ave., CHICAGO—Offices in 47 Cities 52A

## POWERS WATER TEMPERATURE CONTROL

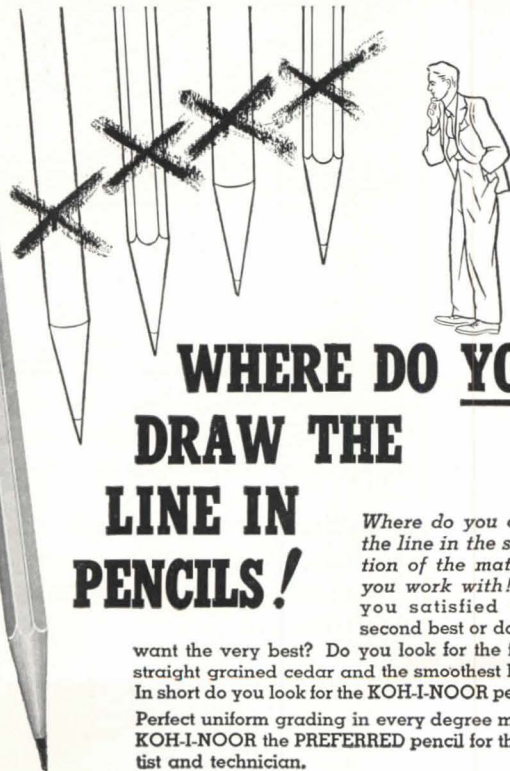

### WHERE DO YOU DRAW THE LINE IN PENCILS!

Where do you draw the line in the selection of the material you work with! Are you satisfied with second best or do you want the very best? Do you look for the finest straight grained cedar and the smoothest lead? In short do you look for the KOH-I-NOOR pencil? Perfect uniform grading in every degree makes KOH-I-NOOR the PREFERRED pencil for the artist and technician.

Send for Leaflet No. 3



The RIGHT pencil for the RIGHT job  
KOH-I-NOOR PENCIL COMPANY, INC., BLOOMSBURY, NEW JERSEY

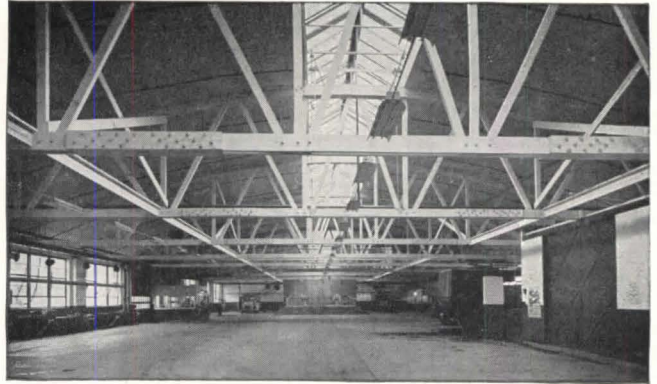

## IMMEDIATE DELIVERY AMERICAN BOWSTRING WOOD TRUSSES REDUCE BUILDING COSTS



Send for Architects  
Data Sheet Free

Your builders won't have to look for scarce labor . . . or hard-to-get materials. For American has the skilled truss men . . . finest materials . . . and the production capacity to deliver immediately or on the date you specify.

25th Anniversary  1922-1947

## AMERICAN ROOF TRUSS CO.

Phone PLAZA 1772  
6844 STONY ISLAND AVE.  
CHICAGO, 49

Phone ADAMS 1-4379  
292 W. SANTA BARBARA AVE.  
LOS ANGELES, 37

## Every Architect should have these STEWART CATALOGS

- Catalog 82, Standard Iron Fences (with Channel Rails, Gates and Arches)
- Catalog 80, Standard Iron Fences (with Angle Rails)
- Catalog 83, Standard Chain Link Wire Fences and Gates
- Catalog R-38, Railings, Pier Lanterns, Interior Gates, Veranda Work, etc.
- Catalog W-40, Window Guards, Wire Mesh Partitions, Folding Gates, etc.
- Catalog I-42, Industrial Fence Specifications Manual

These catalogs contain complete information on Stewart Iron and Wire Products. Check your file of Stewart literature. If you do not have all the catalogs listed above, we shall be glad to send them to you. Stewart also manufactures the following jail and prison equipment: Steel Cells, Bunks, Hinge and Sliding Type Doors, Locks and Locking Devices, Iron Stairways, Gratings, etc. Complete information on request.

**Stewart** IRON and WIRE THE STEWART  
FENCES IRON WORKS CO., Inc.  
1465 Stewart Block  
CINCINNATI 1, O.



FOR MODERN INTERIORS USE PLASTER



## PLASTER GRIPPED by thousands of steel fingers

Notice how the plaster is keyed to the expanded steel mesh of USG\* Metal Lath. This results in one solid slab of steel lath and plaster.

Fire ratings of one hour or more have been given USG Metal Lath and RED TOP\* Plaster partitions and ceiling constructions by recognized testing laboratories, using prescribed plaster mixing proportions and thicknesses.

The reinforced walls and ceilings of USG Metal Lath and plaster have great capacity for retaining their firm smooth surfaces while resisting the strains occasioned by settlement of

foundations, impact and vibration.

USG Metal Lath is readily shaped to ornamental contours to a degree not possible with other type plaster bases. The reinforced plaster slab means unusual resistance against cracks.

To obtain the utmost in fire resistance, flexibility, low maintenance cost and enduring beauty, specify USG Metal Lath and RED TOP Plaster for your quality lathing and plastering.

Write for your copy of the new USG TECHNICAL INFORMATION book, "Metal Lath AIA File Number 20-B."

\*USG and RED TOP used above are registered trademarks which distinguish products manufactured only by the United States Gypsum Company.



# United States Gypsum

**For Building • For Industry**

Gypsum • Lime • Steel • Insulation • Roofing • Paint



# Brasco

MODERN  
STORE FRONTS

*A Complete Line for Every Design*

- SMART, MODERN STYLE
- PERMANENT BEAUTY
- ENDURING STRENGTH
- ASSURED GLASS SAFETY
- HEAVY-GAUGED METALS
- SOUND ENGINEERING
- 30 YEARS' EXPERIENCE

*National Distribution  
Assures Effective Installation*

**BRASCO MANUFACTURING CO.**  
HARVEY • (Chicago Suburb) • ILLINOIS



## Beauty PLUS PROTECTION

Cabot's Creosote Shingle Stains actually dye the wood, bringing out all the natural beauty of the grain. The creosote in Cabot's Stains assures long lasting protection for all outside surfaces. Cabot's Stains are available in a wide variety of colors ranging from brilliant hues to weathering browns and grays.

**Write Today** for a free sample, color card, and complete information. Cabot's Stains are especially suited for today's building conditions because they won't peel or blister, even on green lumber. Cabot's Stains cost less than half as much as good paint. Samuel Cabot, Inc., 1295 Oliver Bldg., Boston 9, Mass.

### Cabot's Creosote Stains



## No Finer Tribute

There is no more fitting memorial to our loved ones than a set of cathedral chimes in a church tower . . . There are no finer chimes . . . for clarity of tone . . . for simplicity of design . . . for beauty of performance than MAAS Genuine Cathedral Chimes.

The perfectly tuned, pure-toned MAAS Chimes will add immeasurably to your worship services . . . and our accumulated know-how makes it possible to offer these Chimes at reasonable prices without sacrifice of quality. Indeed the quality of MAAS Chimes has been improved steadily and consistently until today there is no finer system available.

**MAAS CATHEDRAL CHIMES**

Room 21, 3015 Casitas Avenue Los Angeles 26, Calif.

Write for descriptive literature (Specify organ you have.)

## Contemporary Shops in the United States

By EMRICH NICHOLSON

"Contemporary Shops in the United States" is a treasury of beautiful yet practical samples of store fronts and interiors, selected from among America's most progressive stores.

Including the supplement of 24 pages, over 400 illustrations, plans, etc., showing 113 shops, large and small, handling many lines of merchandise, located from coast to coast, designed by 70 leading designers and architects. 216 pages. 8½ x 11. \$10.00.

Book Department, ARCHITECTURAL RECORD  
119 West 40th Street, New York 18, N. Y.

Please send one copy of CONTEMPORARY SHOPS IN THE UNITED STATES at \$10 per copy.

Money order or check for \$ enclosed  
(For N. Y. City Delivery add 2% Sales Tax — \$10.20 in all)

Name.....

Address.....

City.....Zone.....State.....

A. R. 8-47



# To this builder, too, Petro means the finest in oil heat

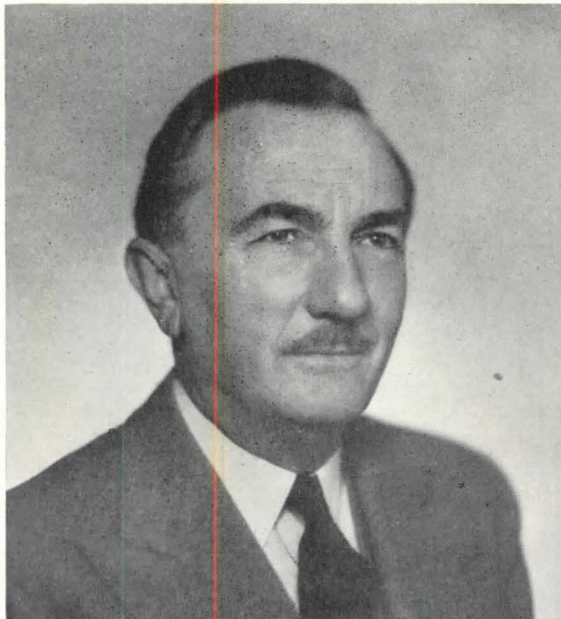

*Anthony Campagna, of the Campagna Construction Corporation, one of America's well-known builders, has constructed many of New York's outstanding apartment buildings. Recognizing the inherent advantages of liquid fuel for modern heating, he says: "Liquid fuel possesses many basic advantages, including its economy in elimination of labor costs and its simplicity and efficiency in operation. I am completely satisfied that the Petro name warrants proved and valuable equipment. From the documented evidence appearing in these pages I know that numerous architects and engineers check with me in their valuation of Petro oil burning systems."*

**INDUSTRIAL MODELS:** No. 5 or No. 6 fuel oil; manual, semi- or automatic operation; 8 sizes to 450 bhp. Thermal Viscosity preheating.

**DOMESTIC MODELS:** No. 3 or lighter oils; "conversion" and combination-unit types, 7 sizes. Patented "Tubular Atomization."

FULL DATA on Petro Industrial Burners are in catalog files of Sweet's and Domestic Engineering. Details on Petro Domestic Burners available in separate catalog. Copy of either sent gladly on request.

AMONG builders, as well as architects and engineers, you find an ever-growing appreciation of the splendid heating performance that distinguishes the Petro Oil Burner.

They endorse Petro design. They recognize what the skilled engineering and precision workmanship throughout a Petro mean in terms of reliable, low-cost operation. They know that behind a Petro stand the resources of the world's oldest, largest exclusive oil burner maker.

With Petro you can rest assured the owner obtains all the economies which only the finest in oil heating equipment provides . . . benefits that help you promote client satisfaction.

# PETRO

REG. U. S. PAT. OFF.

**cuts steam costs**

**PETROLEUM HEAT AND POWER CO. • Makers of Good Oil Burning Equipment Since 1903 • Stamford, Connecticut**



● ASK FOR THEM BY NAME

# EBERHARD FABER



# ERASERS

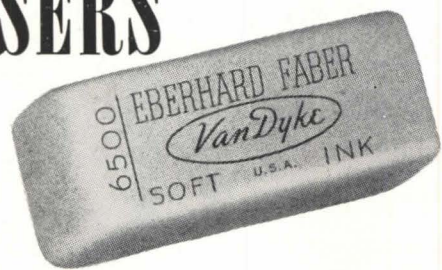

# FOR CLEAN CORRECTIONS

**SPECIFY GRID UNIT HEATERS**

T.M. REG. U.S. PAT. OFFICE

*The Only Unit Heater Free from Electrolysis*

HERE'S WHY!

**HIGH TEST CAST IRON HEATING SECTIONS**

**D.J. MURRAY MANUFACTURING CO.**

WAUSAU • WISCONSIN

It is ONE type metal—high test cast iron—the same metal as the steam supply and return pipes, and the boiler itself. As there are no dissimilar metals anywhere, GRID Unit Heaters cannot be influenced by electrolytic action. No electrolysis can ever develop to cause corrosion, with resultant breakdowns, leaks or heating failures now, or in future years. GRID Unit Heaters will last as long as the pipes furnishing steam to them, and here's why:

- One piece construction heating sections (Patented) of high test cast iron that will withstand steam pressures up to 250 lbs.
- No soldered, brazed, welded nor expanded connections to become loose or develop leaks.

GRID units have been in continuous operation for over 17 years without any maintenance.

Capacity tables and complete details upon request, with booklet "Corrosion in Unit Heaters".

# Walk with *Safety* ON NORTON FLOORS

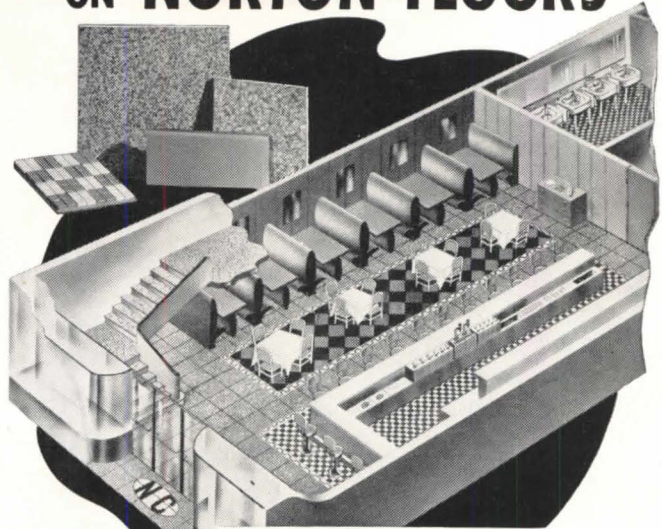

Non-Slip . . . Wet or Dry

**NORTON COMPANY**  
WORCESTER 6, MASS.

Behr-Manning, Troy, N. Y., is a Norton Division

See this catalog in Sweet's.



the **LUMINALL** line  
of interior flat wall paints

LUMINALL . . . has casein binder for extra light reflection

ULTRA LUMINALL . . . has synthetic resin binder for extra washability

FREE . . . Send for fully illustrated 24-page book, "Painting for Light & Decoration."

**NATIONAL CHEMICAL & MFG. CO.**  
3627 South May Street, Dept. G, Chicago 9, Illinois

Factories: Chicago, Ill., Brooklyn, N. Y.  
Distributors in all principal cities



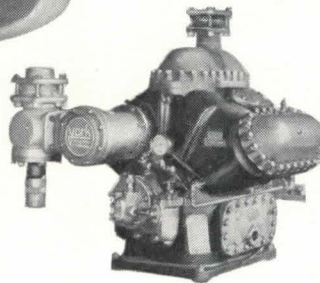
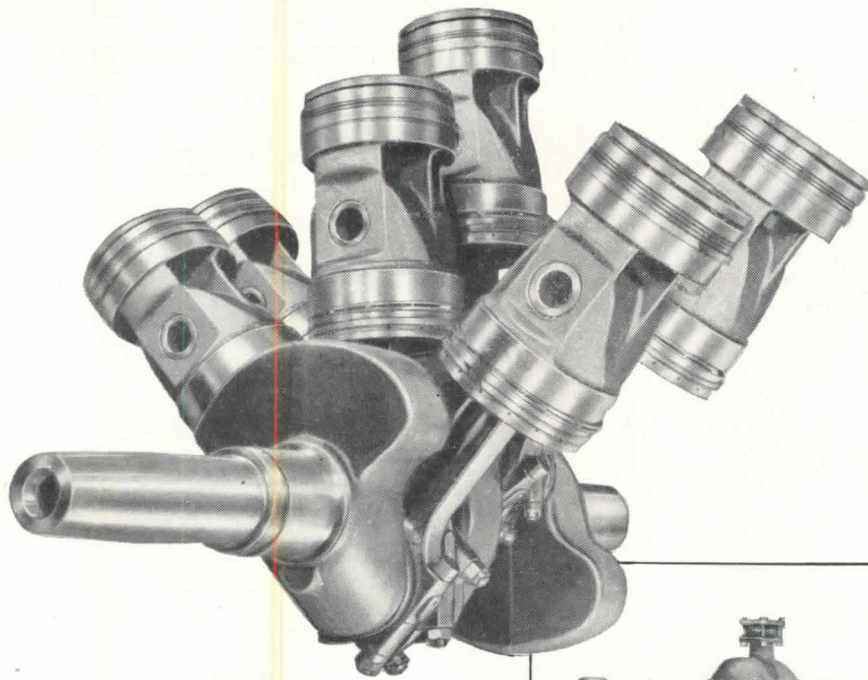

For Competent,  
Authoritative  
Assistance...

**QUICK!**

**CALL ON THE FACTORY-TRAINED  
EXPERIENCED YORK ENGINEER  
IN YOUR NEIGHBORHOOD**

York-trained, seasoned specialists in refrigeration and air conditioning, located at district headquarters throughout the United States are assisting architects, consultants and contractors . . . in planning, purchasing, installing and maintenance.

In the Los Angeles area, for example, District Manager Lauer and his staff of 18 sales engineers devote their full time to the problems of York customers in this region.

## V/W "AIRCRAFT BALANCE" means freedom from vibration

This unique V/W crankshaft and piston assembly is a study in static and dynamic balance and suggests a radial aircraft engine with its lower half placed in line with the upper. In addition to accurate control of the weight of individual parts, the arrangement of rotating and reciprocating parts in this ingenious V/W design results in vibrationless operation. As a result of these innovations, York engineers were able to

produce the first refrigeration compressor that could be mounted on upper floors, in roof trusses, that required no special foundation.

Exclusive design is but one of the many features of V/W "the compressor that never wears out," and is representative of the character of York engineering throughout its complete line of refrigeration and air conditioning equipment.

York Corporation, York, Penna.



**R. F. LAUER**  
District Mgr.

Assisted by:

J. N. Berger	H. T. Orebaugh
E. J. Berlet	M. R. Overbye
K. G. Blessing	G. F. Sainsbury
A. J. Dalin	W. W. Sandholt
F. W. Devers	C. A. Shapiro
W. R. Eby	F. H. Stephens
Maron Kennedy	D. D. Stone
T. A. Marshall	G. H. Walker

**YORK** *Refrigeration and Air Conditioning*



HEADQUARTERS FOR MECHANICAL COOLING SINCE 1885



# LAST WORD

**in unit heater design . . . that's the new Modine Unit Heater Line**

New style and beauty . . . improved heating performance . . . a broad new range of applications for industrial plants and stores—that's what the new 1947 Modine Unit Heater Line now gives you!

Modine now offers three types of unit heaters with 47 basic capacities: 1) Horizontal Delivery Type for general industrial and commercial applications — 2) Vertical Delivery Type for overhead installations — 3) New Power Throw Type for specialized industrial use. See the "Where-to-Buy-it" section of your phone book, or write for free descriptive literature!



Horizontal Delivery Type showing patented Modine center location of supply and return connections for direct suspension.

**MODINE MFG. CO.**  
1773 RACINE STREET • RACINE, WISCONSIN

a complete line of

## METAL and PLASTIC TRIMS

When you specify S&W Mira-Trim you can select exactly the shape, material and finish you want for **exactly** the accent desired. Miraplas—colorful plastic, Mirachrom—bright aluminum, Miralite—non-rub soft finish, Miravel—velvet finish, Mirasteel—gleaming stainless steel. Use Mira-Trim for modern beauty. Quickly available through local distributors everywhere.

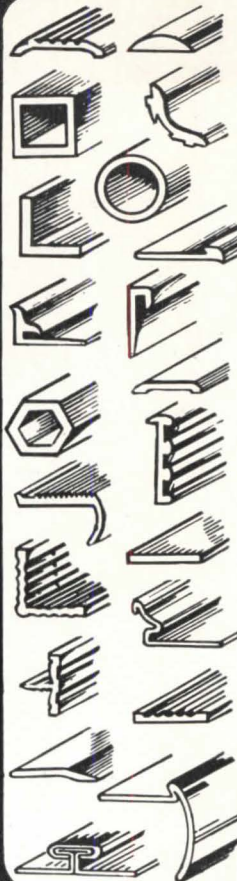

S & W catalogs should be in your file. Sent on request.



**S & W MOULDING CO.**

DEPT. E — COLUMBUS 6, OHIO

*The House of Mira-Trim*

IN CANADA—CANADIAN MOULDINGS LTD., CHATHAM, ONTARIO

What goes UP?

What goes DOWN?

to meet variations in floor levels?  
...THE NEW ADJUSTABLE TOP

**Josam** **LEVELEZE**  
LEVELS EASY  
FLOOR DRAIN

Now... where the drain has been set too high or too low... or where floor level is changed—for any reason—after the LEVELEZE drain is installed, simply raise or lower the adjustable top of the JOSAM LEVELEZE Floor Drain and presto—the new level is met, drainage is assured and the cost of adjustment is negligible. Send coupon below for literature.

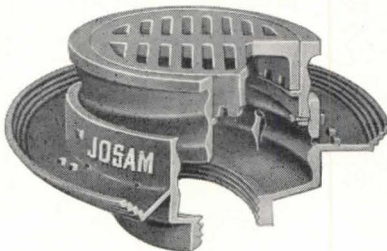

SERIES 3610—with deep set tractor grate shown  
SERIES 3510—with anti-tilting grate optional

Josam Mfg. Co., 302 Ferguson Bldg., Cleveland 14, Ohio

Please send me literature on new Leveleze Floor Drain

Name .....

Firm .....

Address .....

City ..... State .....



THE  
COLOR  
MYSTERY  
SOLVED

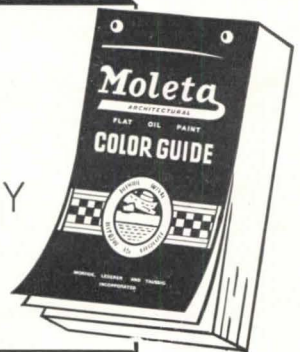

Where, oh where, is the right color? You'll find a quick answer in the Moleta COLOR GUIDE. This handsome COLOR GUIDE gives a selection of 150 beautiful colors to show your clients... each tint displayed on a large page (9" x 15") and shown in true-life, right-on-the-wall effect... every tint from the palest to the darkest. And on the reverse of each sheet is given the exact mixing formula.

Write for your copy of the Moleta COLOR GUIDE—\$5.00, delivered anywhere in the U. S. A.

MONROE, LEDERER & TAUSSIG, INC.  
606 N. American St. Phila. 23, Pa.

**Moleta**  
ARCHITECTURAL

FLAT OIL PAINT  
THE TRULY WASHABLE FLAT PAINT



Available

Again

# TIME-SAVER STANDARDS

Architectural Record's  
ten-year collection . . .  
all in one volume

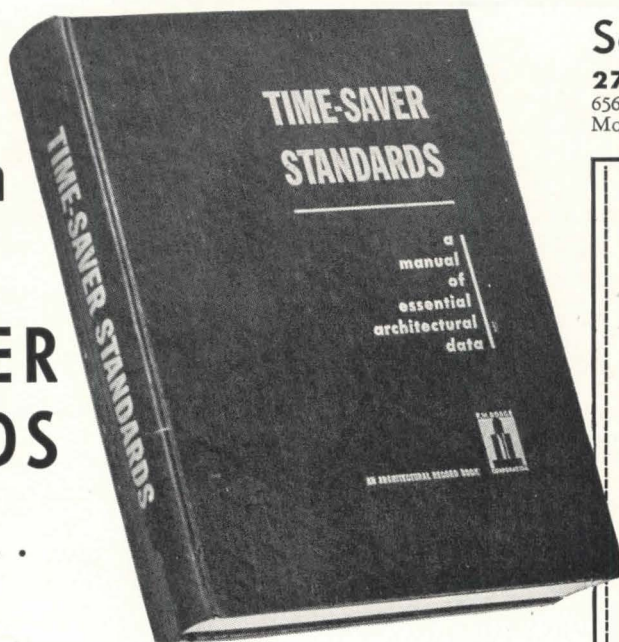

## Second Printing

277 Time-Saver Standards —  
656 Pages; 12-Page Master Index; Size 8 1/2 x 11.  
More than 1,000 illustrations, charts, diagrams

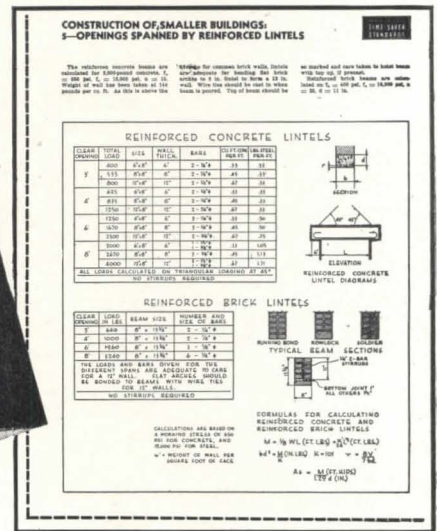

IN RESPONSE to insistent demand for more copies, here, reprinted again in one volume of encyclopedic size, are virtually all the Time-Saver Standards ever published — 277 of them — exactly as they appeared originally in *Architectural Record* and *American Architect* during the past ten years — with one 12-page master index!

Just off the press, for immediate delivery to you, is this work of 656 pages, with a mailing weight of 4 1/2 lbs., containing a complete collection of these now famous authoritative monographs on technical aspects of construction dealing with

- Architectural Design
- Materials Technology
- Engineering Data
- Building Practice

Designed for the practical guidance and every-day use of architects, engineers, specification writers and building technicians, TIME-SAVER STANDARDS will bring you a wealth of detailed information on design and building practice . . . carefully selected from the works of the nation's leading building designers and engineers.

### Well-Organized 12-page Index

This wealth of data is carefully organized and painstakingly presented. It is so thoroughly indexed that there are 1,856 references and cross-references . . . occupying *twelve pages* of closely set print.

Experience shows that a single item in TIME-SAVER STANDARDS can well save hundreds of dollars in economy construction . . . save many hours of *your* valuable time. Yet you can now place this concise and well-organized planning data at your command for the nominal sum of \$12.00 — provided you act now.

### Order Your Copy Now

The first printing of TIME-SAVER STANDARDS last November was sold out almost before publication. Now an unanticipated flood of orders — for extra copies and multiple copies — on top of new orders indicates the second printing will soon be snapped up.

So get your copy now. Don't get caught on a long waiting list. Simply fill out the coupon at right, attach your check or money order for \$12.00, and mail today. Your copy will be rushed to you without delay.

These telescopic outlines of only a very few of the 277 Standards give a quick idea of the detailed treatment accorded each subject.

**Dry-wall Construction.** Materials applicable. Fiber board. Fiber insulation board. Planks and tileboards. Hardboard, Gypsum wallboard. Plywood. Cement asbestos. Plastics. Composite and self-supporting walls and partitions . . . Advantages. Handicaps. Costs. Terminology. Classifications and sizes. Framing and furring. Joints. Nailing and cementing. Flexible fasteners. Finishing. Simplified practices. Uses. Applications. References.

**Heating—Unit Heaters.** Typical Heat sources. Boiler capacity. Characteristics. Location. Selection data. Capacities. Controls. Fresh Air connections. Pipe connections. Louvres. Grilles. Deflectors.

**Basement Waterproofing.** Impermeability of concrete cracks and joints in masonry. Hydrostatic pressure. Recommended concrete mixtures. Effect of curing time on permeability. Integral and membrane methods. Plastic and iron coating. Cement-base coatings.

**Folding Partitions.** Center hung doors. Pair-operated doors. Pockets. Passage through closed partitions. Door construction and soundproofing. Rolling partitions. Folding fabric partition.

**Lighting.** Recommended levels of illumination. Fixtures for filament and mercury lamps. Luminaire spacing. Room index. Coefficients of illumination. Layout suggestions. Conformity with structural design. Computed values of illumination. Lumen output of lamps.

**Noise Reduction Acoustical Materials.** A rule-of-thumb answer to what noise coefficient to use. Special applications. Materials for plastic application. Costs. Appearance. Design. Fire resistance. Light reflection. Heat transmission. Lighting. Pre-cast materials. Effect of paint. Acoustical Units: Wood framing; metal suspension systems.

ARCHITECTURAL RECORD BOOK DEPARTMENT  
119 West 40th Street, New York 18, N. Y.

Enter my order for \_\_\_\_\_ copies of  
the second printing of the 656-page TIME-SAVER  
STANDARDS at \$12.00\* a copy. I enclose \$\_\_\_\_\_

\* Add 24 cents for New York City delivery — \$12.24 in all.

Name \_\_\_\_\_

Address \_\_\_\_\_

City \_\_\_\_\_ Zone \_\_\_\_\_

State \_\_\_\_\_



*The Old ReliABLE*

**PORCELAIN ON STEEL  
"ABolite" REFLECTORS**

Quality that meets every lighting requirement has always been the watchword of "ABolite" Reflectors. They are recognized throughout the lighting field for flawless construction, durability, ease of installation and maintenance.

A few of the standard types are shown. The complete "ABolite" line includes other types for outdoor use, protective lighting, sports and parking areas, filling stations and sign lighting. For every application where high efficiency with porcelain on steel enameled reflectors and floodlights is required.

*ABolite Reflectors are sold exclusively through electrical wholesalers. Catalog for specifications sent on request.*



SEPARABLE SOCKET TYPE  
RLM STANDARD DOME



THREADED NECK TYPE  
GLASS-STEEL DIFFUSER



FORMED NECK TYPE  
DEEP BOWL



OPEN TYPE  
FLOODLIGHT  
ELLIPTICAL  
ANGLE

Light right  
with . . .



THE JONES METAL PRODUCTS CO., WEST LAFAYETTE, OHIO

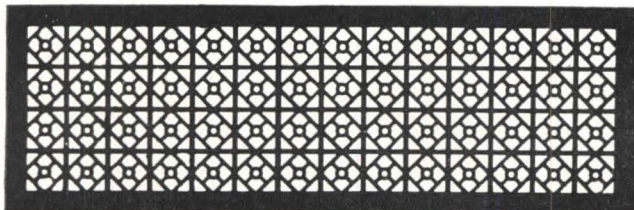

of individualistic design . . .  
**HENDRICK GRILLES**

are offered in over a hundred distinctive patterns — many of them developed to meet some architect's specific ideas, but now available, without premium, for your customers.

Hendrick decorative grilles are fabricated in heavy-gauge aluminum, bronze, copper, Monel, steel and stainless steel. With ample open areas; accurate sizes; clean-cut perforations, with no burrs or other imperfections. Write for full information.



Perforated Metals  
Perforated Metal Screens  
Architectural Grilles  
Mitco Open Steel Flooring,  
"Shur-Site" Treads and  
Armorgrids

**HENDRICK**  
*Manufacturing Company*  
38 DUNDAFF STREET, CARBONDALE, PA.  
Sales Offices in Principal Cities

**CASTELL LOCKTITE**

the professional  
man's refill drawing  
pencil which embraces  
these exclusive features

**QUICK**—Just press your thumb on the button release. Eliminates two-hand screwing or turning operation.

**CLEAN**—No need to touch the lead and get graphite particles or dust on your fingers or smudges on your drawing. Hold point to paper, press button, lead can be adjusted upward or downward.

only \$1

at your  
Art Supply  
House,

Drawing  
Material  
Dealer, Blue  
Printer, Stationer  
or Photographic  
Supply Shop.

for drawing  
sketching  
retouching

**NON - BREAKAGE**

—an unusually fine precision collet supports the graded lead all the way around and prevents it from breaking or snapping off under greater than normal pressure during the pointing or sanding process or when in actual use.

Holds all standard makes of refill graded drawing and retouching leads. We recommend WINNER Techno-Tone 1930.



*In Insulation...*  
**HERE IS SOMETHING  
BETTER UNDER THE SUN!**

From the architect's point of view, insulation is specified with thermal efficiency as a prime consideration.

**INFRA ACCORDION ALUMINUM INSULATION** has C factors of:  
.072 (DOWNWARD HEAT; equals 6-7/8" rockwool)  
.095 (UPWARD HEAT; equals 3-1/2" rockwool)  
.10 (LATERAL HEAT; equals 3-1/3" rockwool)

That's why more and more architects specify **INFRA ACCORDION ALUMINUM INSULATION!**

Interesting up-to-the-minute **FACTS** about Infra . . . such as actual absence of condensation, mold-proof characteristics, ease and economy of handling and installation . . . are now available. A list of recent Infra installations, with names of architects, sponsors and builders . . . and a sample of **INFRA** . . . is also yours for the asking.



*Thermal factors stamped on every carton*

**INFRA**  
*Insulation*  
INCORPORATED  
10 MURRAY STREET - NEW YORK, N. Y.

ALUMINUM AND TRIANGULAR  
AIR CELLS  
CONSERVE WINTER HEAT  
REPEL SUMMER SUN

REJECTS  
INFRA-RED RAYS



**SO WE MADE 3 GYMS  
in ONE!**

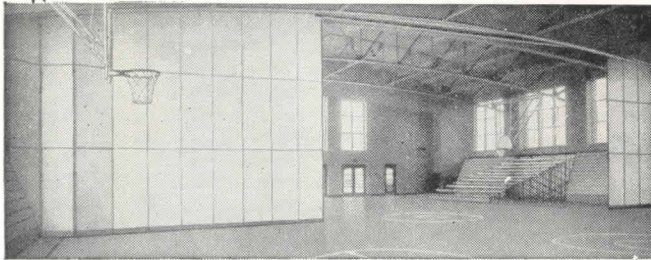

**HORN FOLDING  
PARTITIONS  
HORN FOLDING  
BLEACHERS**

FOR COMPLETE INFORMATION WRITE

**HORN BROTHERS CO.**

FORT DODGE, IOWA

ESTABLISHED 1909

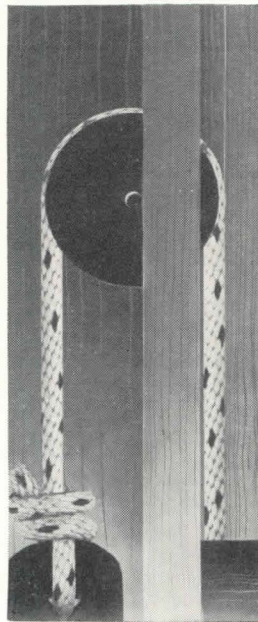

The Colored Spots are our Trade Mark, Reg. U.S. Pat. Off.

**SPOT SASH CORD**

WITH WEIGHTS AND PULLEYS

— the one method of hanging windows that has been proved by generations of actual use to provide perfect and permanent balance.

SAMSON CORDAGE WORKS • BOSTON 10, MASS.



**GENERAL CONTROLS . . .**  
THE ACKNOWLEDGED STANDARD IN  
AUTOMATIC PRESSURE, TEMPERATURE  
AND FLOW CONTROL UNITS

Here are a few of an outstanding line of controls for Industrial, Commercial and Domestic applications.

- ★ ALL-GAS CONTROLS
- ★ AIRCRAFT CONTROLS, ELECTRIC
- ★ AUTOMATIC SAFETY PILOTS
- ★ GAS REGULATORS
- ★ LOW WATER CONTROLS
- ★ GOVERNOR TYPE VALVES
- ★ HI-LOW-OFF VALVES
- ★ INDUSTRIAL VALVES
- ★ LOW PRESSURE GAS VALVES
- ★ MOTOR OPERATED VALVES
- ★ MAGNETIC GAS VALVES
- ★ PILOT BURNERS
- ★ PILOT GENERATORS
- ★ REFRIGERATION VALVES
- ★ SOLENOID VALVES
- ★ STRAINERS—RELAYS
- ★ 100% SHUT-OFF VALVES
- ★ THERMOSTATIC CONTROLS
- ★ TRANSFORMERS—SWITCHES
- ★ THERMOPILOTS

Controls for air, water, steam, natural, manufactured and liquefied petroleum gases, light and heavy oils, etc., refrigerants such as: freon, methyl chloride, sulphur dioxide and ammonia. PROVED AND IMPROVED PERFORMANCE IS PROOF THAT YOU CAN'T BUY BETTER CONTROLS.

**GENERAL CONTROLS**  
801 ALLEN AVENUE GLENDALE 1, CALIF.

Manufacturers of Automatic Pressure, Temperature and Flow Controls  
BRANCH OFFICES AND DISTRIBUTORS IN ALL PRINCIPAL CITIES

FOR COMPLETE SPECIFICATIONS  
REQUEST NEW CATALOG.

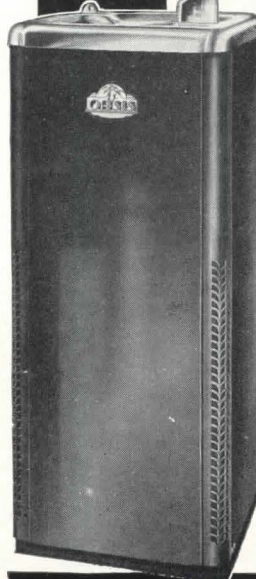

— and first in line with features that combine low-cost water cooler efficiency with distinctive cabinet beauty in keeping with any interior. OASIS Electric Water Coolers offer smart, stainless steel tops . . . smooth-working dial-type bubblers of highly simplified design . . . rugged, long wearing construction in every detail . . . many other advantages developed during EBCO's 20 years of water cooler leadership. Full range of sizes for all types of installations in bottle or pipe-connected pressure models. Write for details.

EBCO glass fillers also available

THE **EBCO** MANUFACTURING COMPANY  
401 W. Town St., Columbus 8, Ohio



# INDEX TO ADVERTISEMENTS

Catalogs of concerns marked (s)  
are filed in Sweet's File (1947)

s Adam, Frank, Electric Company.....	59	Hendrick Manufacturing Company.....	198	s Ozalid Products Division.....	186
s Adams & Westlake Company.....	163	s Herring-Hall Marvin Safe Co.....	62	s Petroleum Heat & Power Company.....	193
Air Reduction.....	189	s Hillyard Sales Co.....	142	s Pittsburgh Corning Corporation.....	201
Alan Wood Steel Company.....	14	s Hood Rubber Co.....	40	s Pittsburgh Plate Glass Company.....	154-155
s Aluminum Company of America.....	147	s Horn Brothers Co.....	199	s Pittsburgh Reflector Company.....	123
s American Brass Company.....	45	s Imperial Brass Mfg. Company.....	6	Ponderosa Pine Woodwork.....	133
s American Lumber & Treating Company.....	150	s Independent Lock Co.....	42	s Porcelain Enamel Institute, Inc.....	60-61
s American Radiator & Standard Sanitary Corporation.....	13	s Infra Insulation Inc.....	198	s Portland Cement Association.....	56
American Roof Truss Company.....	190	s Insulite Division.....	11	s Powers Regulator Company.....	190
s American Telephone & Telegraph Co.....	48	s International Business Machines Corporation.....	32	Prestile Manufacturing Co.....	180
s American Tile & Rubber Co.....	128	s International-Van Kannel Revolving Doors.....	26	s Pryne & Co., Inc.....	142
s Anaconda Copper Mining Co.....	45	s Jamestown Metal Corporation.....	184	s Radio Corporation of America.....	35
s Anchor Post Products, Inc.....	144	s Jamison Cold Storage Door Company.....	134	s Republic Steel Corporation.....	187
s Andersen Corporation.....	41	s Johns-Manville.....	44-179	s Revere Copper & Brass, Inc.....	165
s Anemostat Corporation of America.....	17	s Jones Metal Products Co.....	198	s Reynolds Metals Company.....	53-65
s Armstrong Cork Company.....	25	s Josam Manufacturing Co.....	196	s Richards-Wilcox Mfg. Co.....	126
s Arrow-Hart & Hegeman Electric Co.....	170	s Kawneer Company.....	50-51	Richmond Radiator Company.....	65
s Bell & Gossett Company.....	151	s Kewanee Boiler Corporation.....	46	s Ric-Wil Company.....	63
s Bell Telephone System.....	48	s Kimberly-Clark Corporation.....	38	s Robertson, H. H., Co.....	49
s Bethlehem Steel Company.....	54-175	s Koh-I-Noor Pencil Co., Inc.....	190	s Rotary Lift Co.....	137
s Bird & Son, Inc.....	146	Kompelite Building Materials, Inc.....	37	s Russell, F. C., Company.....	168
Bituminous Coal Institute.....	156	s Lawson, F. H., Co.....	178	S. & W. Moulding Co.....	196
s Blank, Frederic, & Co., Inc.....	22	s Libbey, Owens-Ford Glass Company.....	64	s Samson Cordage Works.....	199
Books.....	150-162-180-192-197	Lith-I-Bar Co.....	144	s Sarco Company, Inc.....	188
s Borg-Warner Corporation.....	36	s Lockwood Hardware Mfg. Co.....	42	Schlage Lock Company.....	130
Brasco Manufacturing Co.....	192	Lone Star Cement Corporation.....	1	s Scott Paper Company.....	181
Bryant Heater Company.....	169	s Louisville Cement Company, Inc.....	135	s Seapocel Porcelain Metals, Inc.....	174
s Bull Dog Electric Products Company.....	153	Mass Organ Company.....	192	Servel, Inc.....	158-159
Burnham Boiler Corporation.....	131	s Macomber, Incorporated.....	138	Simpson Logging Company.....	143
s Burt Mfg. Co.....	30	s Mahon, R. C., Company.....	39	s Sloan Valve Company.....	4th Cover
Byers, A. M., Co.....	4	Marsh Wall Products, Inc.....	136	s Smith, H. B. Co., Inc.....	145
s Cabot, Samuel, Inc.....	192	s Martin-Parry Corporation.....	139	s Soss Manufacturing Company.....	40
Cardox Corporation.....	178	Masland Duralather Company.....	149	s Stewart Iron Works Co., Inc.....	190
s Ceco Steel Products Corporation.....	2-3	Melflex Products Co.....	164	s Stran Steel Division.....	23
s Celolux Corporation.....	117	s Mengel Company.....	58	s Streamline Pipe & Fittings Division.....	185
s Century Lighting, Inc.....	186	s Mesker Brothers.....	34	Stromberg-Carlson Co.....	16
s Cheney Industries.....	184	Mesker, Geo. L., Steel Corp.....	176	Supro-Lux Manufacturing, Inc.....	188
Committee on Steel Pipe Research.....	160	Michaels Art Bronze Company, Inc.....	12	Taylor Manufacturing Co.....	170
s Corning Glass Works.....	8-9	s Milcor Steel Company.....	202	s Trade-Wind Motorfans, Inc.....	148
s Coyne & Delany Company.....	186	s Minneapolis-Honeywell Regulator Co.....	66	s Trane Company.....	171
Crane Co.....	127	s Minnesota & Ontario Paper Company.....	11	s Trumbull Electric Mfg. Co.....	21
s Cutler Mail Chute Co.....	188	s Modine Manufacturing Co.....	125-196	s Truscon Steel Company.....	187
s Day-Brite Lighting, Inc.....	118	Manroe, Lederer & Taussig, Inc.....	196	s United States Air Conditioning Corp.....	140
s Detroit Steel Products Company.....	19	s Moulding, Thos., Floor Mfg. Co.....	166	s United States Gypsum Company.....	191
s Dravo Corporation.....	24	s Mueller Brass Co.....	185	s United States Plywood Corp.....	58
s Dresser Industries.....	169	Murray, D. J. Manufacturing Co.....	194	s United States Steel Corporation Subsidiaries.....	18-183
s Duriron Co., Inc.....	132	Naco Manufacturing Co.....	164	s Universal Atlas Cement Company.....	18
Ebcoc Manufacturing Co.....	199	s National Chemical & Mfg. Co.....	194	Vulcan Radiator Co.....	43
Electric Storage Battery Company.....	157	National Electric Products Corporation.....	29	s Wade Manufacturing Co.....	174
Employment Opportunities.....	182	s National Gypsum Company.....	167	Wakefield, F. W. Brass Company.....	47
s Enterprise Engine & Foundry Co.....	152	s National Radiator Company.....	177	s Webster, Warren & Co.....	148
Faber, A. W., Inc.....	198	s National Terrazzo & Mosaic Association, Inc.....	168	s Werner, R. D. Co., Inc.....	182
Faber, Eberhard.....	194	National Tube Company.....	183	s Westinghouse Electric Corporation.....	3rd Cover
s Fitzgibbons Boiler Company, Inc.....	120	Norfolk & Western Railway.....	55	s Wing, L. J. Mfg. Co.....	146
Flintkote Company.....	2nd Cover	Norge Division.....	36	Wood Fiber Division.....	143
s Flynn, Michael Manufacturing Co.....	141	s Norton Company.....	194	Woodwork Corporation of America.....	173
s Formica Insulation Co.....	33	Ohio Chemical & Mfg. Company.....	129	Wurlitzer, Rudolph Co.....	57
s General Aniline & Film Corp.....	186	Ohio Hydrate & Supply Co.....	172	s York Corporation.....	195
General Controls.....	199	Okonite Company.....	184	s Young Radiator Co.....	166
s General Electric — Air Conditioning.....	161	s Otis Elevator Company.....	52		
General Electric — Wiring.....	15				
s General Pencil Company.....	176				
s Grand Rapids Hardware Co.....	172				
s Great Lakes Steel Corporation.....	23				
Guth, Edwin F., Company.....	31				
s Hart & Hegeman Division.....	170				
s Haws Drinking Faucet Co.....	186				
Haynes Products Company.....	188				
Hazard Insulated Wire Works Division.....	184				

NEW YORK — H. Judd Payne, General Manager; Robert F. Marshall, Business Manager; Tom Tredwell, Advertising Mgr.; Benton B. Orwig, Creative Service Manager, 119 West 40th Street; BOSTON — Harry M. Horn, Jr., 855 Park Square Bldg.; CHICAGO — Jack Casey, C. B. Riemersma, 700 Merchandise Mart; CLEVELAND — John C. Jackson, 321 Hanna Bldg.; LOS ANGELES — Bob Wettstein, Room 816, 816 West 5th St.; PHILADELPHIA — Tom Tredwell, 1321 Arch St.; SAN FRANCISCO — Bob Wettstein, 1085 Monadnock Bldg., 681 Market St.



The modern material for modern buildings

# PC GLASS BLOCKS

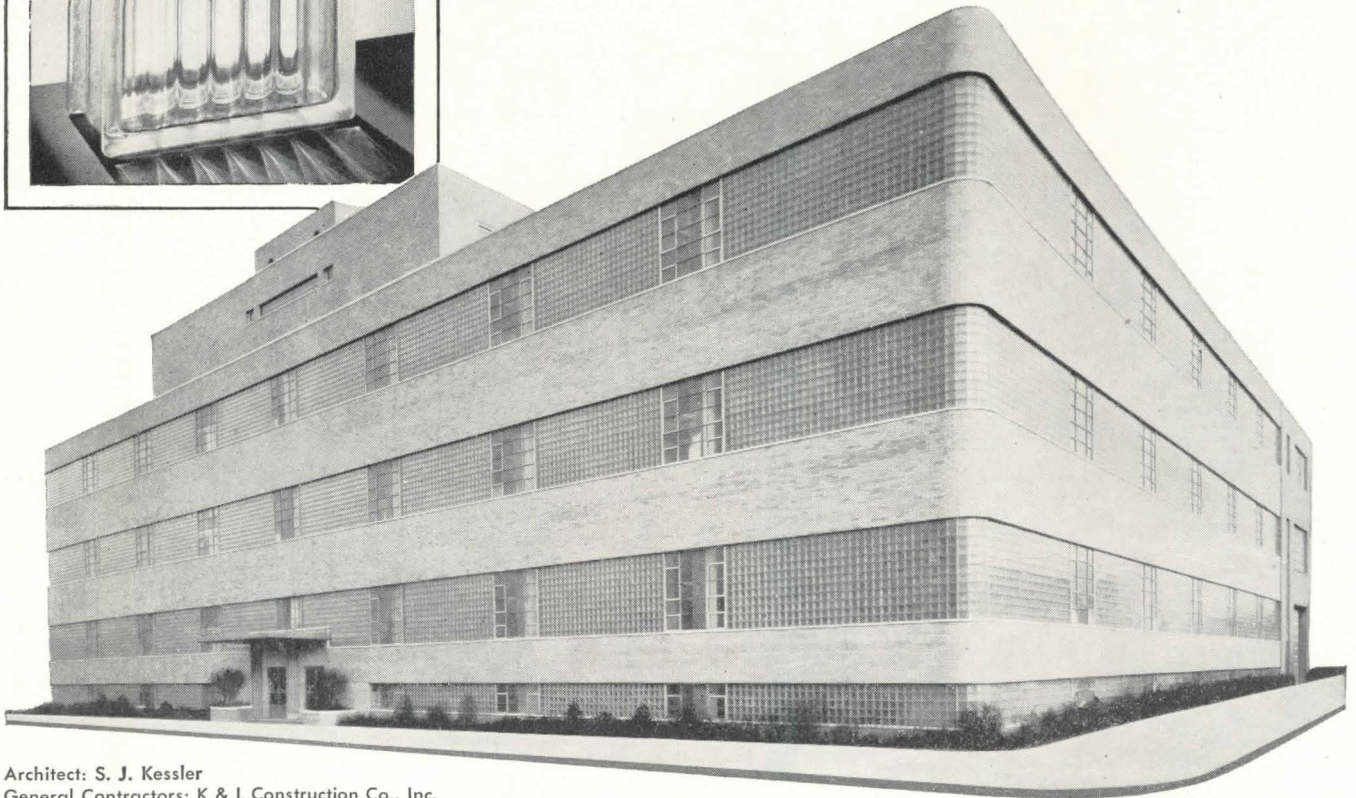
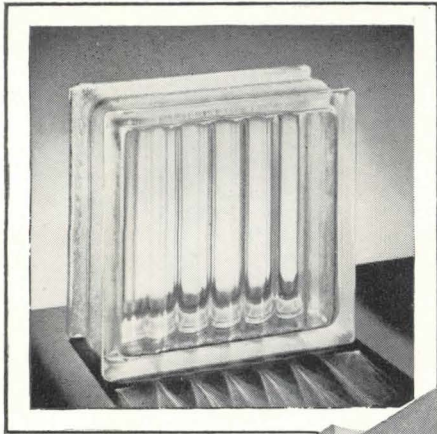

Architect: S. J. Kessler  
General Contractors: K & L Construction Co., Inc.

▶ Modern appearance, modern efficiency, modern economy—those are the main advantages your clients get when you specify PC Glass Blocks.

Panels of gleaming glass blocks make any plant a thing of beauty. Spacious interiors, with plenty of cheery clear daylight, are pleasant places to turn out good work. And the light can be directed to where it is needed most, even to areas remote from light openings.

PC Glass Blocks are hollow, have definite insulating properties. Heat losses through light

transmitting areas are reduced to the minimum. Desired temperatures are easier to maintain and condensation is minimized. Infiltration of destructive dust and grit is prevented.

These are some of the reasons why many architects are specifying PC Glass Blocks for new construction and for modernizing projects. You will want to know all the advantages your clients get with PC Glass Blocks. Send the convenient coupon today for our authoritative booklet. The Pittsburgh Corning Corporation also makes PC Foamglas Insulation.

**PC GLASS BLOCKS . . . the mark of a modern building**



## GLASS BLOCKS

Distributed by PITTSBURGH PLATE GLASS COMPANY  
by W. P. Fuller & Co. on the Pacific Coast and  
by Hobbs Glass Ltd. in Canada

• FOR ADDITIONAL INFORMATION SEE OUR INSERTS IN SWEET'S CATALOGS

Pittsburgh Corning Corporation  
Room 662, 632 Duquesne Way  
Pittsburgh 22, Pa.

Please send along my free copy of your new book on the use of PC Glass Blocks for Industrial Buildings. It is understood that I incur no obligation.

Name.....

Address.....

City..... State.....



Assembly-line building operations effect cost savings that enable the Byrne Organization to produce, in today's market, this three-bedroom, steel-framed house for under \$7,000 — at Harundale, Maryland.

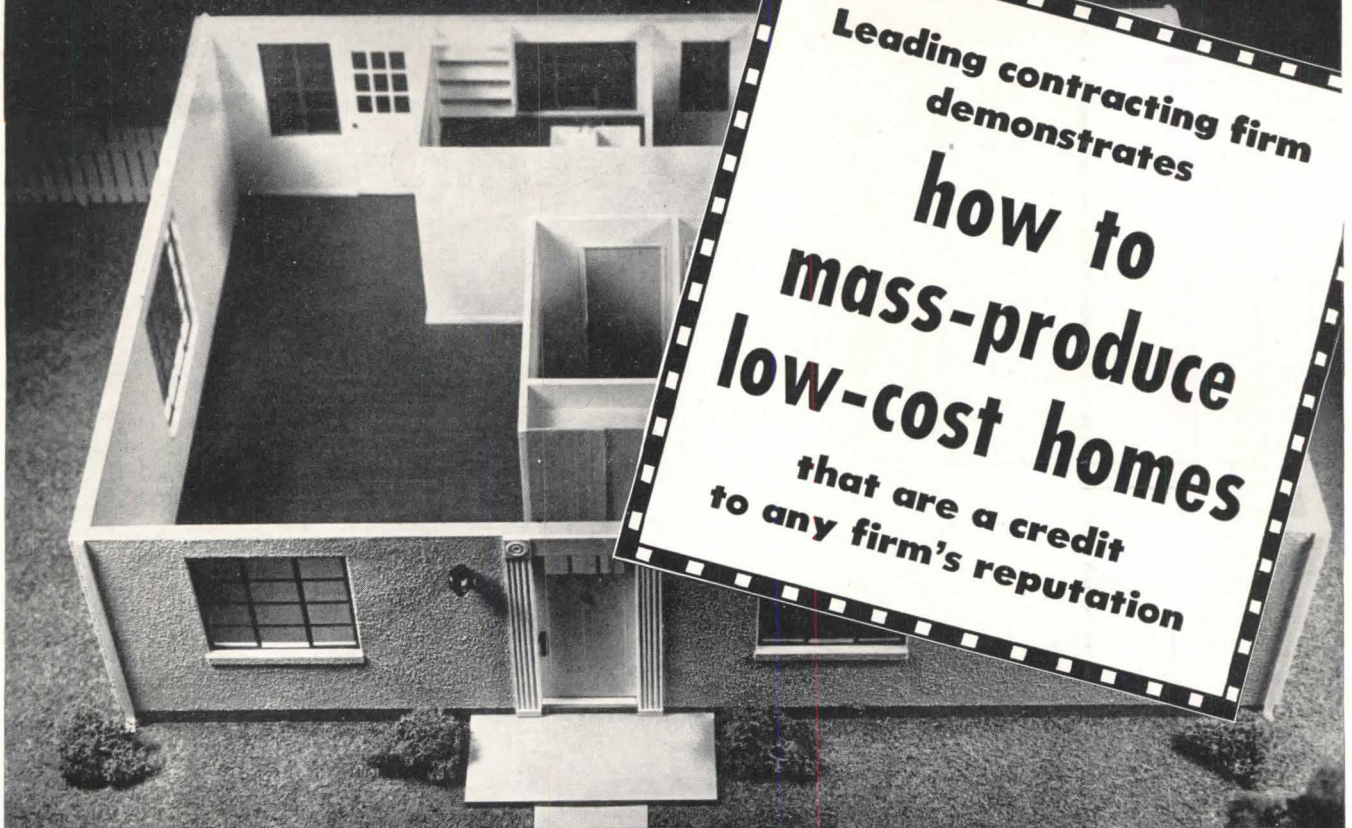

## ... by utilizing the versatility of **Milcor Steel Building Products**

By applying repetitive operations to line-production methods in the field, The Byrne Organization, Washington, D.C., builds really substantial housing for veterans — at low cost.

At present, the Byrne method is being applied to some 4,500 steel-framed homes — all embodying details of quality, materials, and workmanship hitherto unavailable to home owners of moderate means. The speed of erection is amazing. The structures are lighter,

stronger, less costly — and far safer against fire hazards.

Perhaps the use of Milcor Steel Building Products at the Harundale housing project — a Byrne-planned community five miles south of Baltimore, Maryland — may suggest ways to similarly improve the efficiency of erection for the homes you design and build:

Here, *Milcor Steel Studs*, used as framing, are assembled in the shops

and welded together on the site. They are used also in hollow partitions between rooms.

*Milcor Metal Lath* provides continuous steel reinforcement for the three-coated plaster interior walls and the stucco exterior walls.

*Milcor Metal Base*, used as interior trim, simplifies finishing; is permanent, sanitary, economical to maintain.

*Milcor Louver Ventilators* provide air circulation that relieves summer heat and retards moisture condensation in winter.

Consult the Milcor Manual in Sweet's, for data that helps you apply these and other Milcor Steel Building Products to your particular problems.

*Left:* Tying Milcor Metal Lath to Milcor Steel Stud — in a Harundale home. Note the use of *Milcor Corner Bead*, to protect the straight-edge beauty of plaster corners.

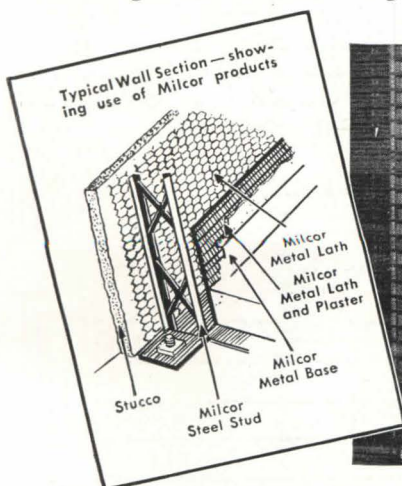

**MILCOR**  
MILCOR STEEL COMPANY  
Inland Steel Products  
MILWAUKEE 1, WISCONSIN

Baltimore 24, Md. Buffalo 11, N. Y.  
Chicago 9, Ill.  
Cincinnati 25, Ohio Cleveland 14, Ohio  
Detroit 2, Mich.  
Kansas City 8, Mo. Los Angeles 23, Calif.  
Rochester 9, N. Y.