

★
ART MAGAZINE



BOOK No.

ACCESSION

720.5 Ar24¹³³

467847

NOT TO BE TAKEN FROM THE LIBRARY

FORM 3427-3M-6-38

C

THE
ARCHITECT
AND
ENGINEER

APRIL
1938



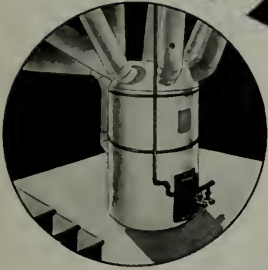

when it RAINS
and
RAINS
and
RAINS
and
RAINS

you won't have to worry
about a leaky basement
if you BUILD WITH

No element in home construction is more important than protection against moisture. Leaky basements can cause untold damage. Flooded furnace pits create dangerous situations. Porous stucco that absorbs dampness and moisture can ruin decorations and hasten depreciation. ♦ When you build, seal out dampness forever by insisting on Golden Gate TAN PLASTIC Portland Cement for all concrete and stucco work.

RIGHTLY USED IT NEVER DISAPPOINTS
*Leading architects specify it... competent builders use it...
reliable dealers handle it.*



PACIFIC PORTLAND CEMENT COMPANY
SAN FRANCISCO • LOS ANGELES COASTWIDE SERVICE PORTLAND • SEATTLE

*720.5 133
Av24

467847

THE ... ARCHITECT & ENGINEER

April .. 1938 .. Contents

COVER

NIGHT VIEW OF ROSENBERG'S STORE BUILDING, SANTA ROSA, CALIFORNIA
Hertzka & Knowles, Architects

EDITOR
Fred'k W. Jones

CONSULTING BOARD
OF EDITORS

FRONTISPIECE

DETAIL OF TOWER, ROSENBERG'S DEPARTMENT STORE BUILDING, SANTA ROSA, CALIFORNIA
Hertzka & Knowles, Architects

Architectural—

Arthur Brown Jr.
Frederick H. Meyer
Timothy L. Pflueger
Will G. Corlett
Harry Michelsen
Lewis P. Hobart
David C. Allison
Gordon B. Kaufmann
Harris C. Allen

Engineering—

H. J. Brunnier
L. H. Nishkian
William Adrian
Wm. H. Popert
Homer N. Hadley
Geo. E. Atkins

Business Manager—

Edgar N. Kierulff

Advertising Manager—

J. Leslie Meek

Architects' Reports—

Vernan S. Yallop

THE ARCHITECT AND ENGINEER, INC., 68 Post Street, San Francisco, EXbrook 7182. President, K. P. Kierulff; vice-president, Frederick W. Jones; secretary, L. B. Penhorwood. Los Angeles office, 832 W. Fifth Street. Published on the 12th on each month. Entered as second class matter, November 2, 1905, at the Postoffice at San Francisco, California, under the Act of March 3, 1897. Subscriptions: United States and Pan America, \$3.00 a year; Foreign countries, \$5.00 a year; single copy, \$.50.

TEXT

A SMALL-TOWN BIG-CITY DEPARTMENT STORE	15
Fred W. Jones	
THE SKYROOM, ATOP HOTEL EMPIRE, SAN FRANCISCO	20
HOUSING SHORTAGE IN CALIFORNIA AT CRITICAL STAGE	25
"MEN IN SMOCKS"	31
MODERNIZATION CREDIT PLAN	35
C. A. West	
HOME BUILDING SIMPLIFIED BY CONSTRUCTION CONTROL	41
W. H. Lowe	
ARCHITECT HAS SOLUTION TO LABOR EMPLOYMENT	43
DESIGN AND CONSTRUCTION OF THE SAN FRANCISCO WORLD'S FAIR	45
John J. Gauld, C. E.	
WITH THE ARCHITECTS	53
LANDSCAPE ARCHITECTS	54

PLATES AND ILLUSTRATIONS

ROSENBERG'S DEPARTMENT STORE, SANTA ROSA	15-19
Hertzka & Knowles, Architects	
SKYROOM, HOTEL EMPIRE, SAN FRANCISCO	20-23
Douglas D. Stone, Architect; Lau B. Mulloy and Hertzka & Knowles, Associate Architects	
FOUR MODELS FOR RICHMOND GARDENS PROJECT	24-29
Edwin L. Snyder, Architect	
RESIDENCE FOR MAJOR H. L. TOPLETT	30
H. Roy Kelley, Architect	
RESIDENCE FOR MR. AND MRS. EDWARD MADDOCK	34
H. Roy Kelley, Architect	
CENTRAL THEME TOWER, SAN FRANCISCO WORLD'S FAIR	45-47
ADOBE HOUSES, FRESNO	50-51

Notes and Comments

California cities should feel a certain amount of pride in having up to date building codes. Many Eastern cities are still operating with 20 year old codes, a condition anything but creditable to their administrations. There appears to be a lamentable lack of initiative shown by most cities in the United States in establishing proper building codes to effect economies which will meet the low cost requirement of most prospective home owners.

In an almost unbelievable number of cities building codes are now in operation which were prepared ten to twenty years ago and have not been revised or amended since. These codes fail to take into consideration the advances made in the scientific and efficient use of structural materials. In all such codes numerous changes could be made which would in the aggregate reduce building costs while still retaining safe structural requirements.

The strange thing about this condition is the fact that it exists in face of a "housing conscious nation," stimulated by the possibilities of improving the living conditions of their citizens and their community aspect by slum clearance and the erection of new low cost homes.

* * *

Mobilization of 12,000 architects throughout the United States to cooperate with the Federal government in stimulating small home building, slum clearance and low cost housing is announced by the American Institute of Architects. Anticipating the biggest small homes building movement in the history of the country as a result of the amended Federal Housing act, which President Roosevelt approved February 4, the Institute is doing everything possible to cooperate.

The country has been divided into ten regions, each with an architectural consultant, appointed by Administrator McDonald for the purpose of explaining the program.

The Institute has solicited the cooperation of every regional and city planning commission in the United States. These groups were urged to make immediate surveys to determine accurately housing conditions in their respective territories.

A most serious situation exists in nearly every city regarding privately promoted housing because in many areas no mortgage insurance can now be obtained.

"These areas," a Housing official explains, "are not properly eligible because of wrong zoning, no zoning, lack of real property inventory or a land use survey insufficient or no neighborhood conveniences—such as parks, playgrounds, churches and amusements—deteriorated neighborhoods, lack of prop-

er streets, and transportation; bad special assessments and tax situations in some districts. In short, this lack of coordinated planning is the principal reason for giving low appraisals or preventing financing of new construction and alterations in these districts, a condition reported by banks, loan companies, insurance companies, and the government agencies. These difficulties are bound to hinder the development of any slum clearance or private industry building program."

Probably few people know how bad the situation is in any city. Obviously, an accurate check-up should be made as soon as possible. Some parts of the city will be found easier to rehabilitate and will need less rezoning or other improvements than others.

* * *

Contracts awarded for building and engineering work in the 37 eastern states during the month of February amounted to \$119,038,000, according to F. W. Dodge Corporation. This was a decline of 37 per cent from February, 1937, and followed a drop in January of 20 per cent from January of last year. Thus the decline of the later months of 1937 has carried through the opening months of the new year. This is the customary course of

a recession like the present one, when many projects are deferred pending assurances of construction cost stabilization, change of general business sentiment, and, in the present case, legislative action.

It is currently reported that preliminary applications for mortgage insurance, both on single dwellings and development projects for sale and for rent, have greatly increased since enactment of the new amendments to the National Housing Act; this may be an indication of increased residential building contracts some weeks hence.

TRIFLES

Michelangelo was explaining to a visitor a number of additions and alterations which he had made to a statue.

"These are trifles," said his friend. "It may be so," said Michelangelo, "but remember that trifles make perfection, and perfection is no trifle."

Again a consolidation of architectural magazines. First the American Architect, sponsored by Mr. Hearst, took over Architecture. Now Architectural Record takes over American Architect. This leaves but three architectural magazines in the national field—the Forum, Record and Architect and Engineer. Pencil Points, devoted more to the activities of draughtsmen, continues to prosper.

* * *

Inferior equipment termed "air conditioning" but producing unregulated drafts of air at improper degrees of temperature and humidity, is still being offered the public, and if its sale continues the result may well be a public reaction and a wave of regulation which will affect not merely the second-rate manufacturers, but engineers and installers, also those who conscientiously wish to give the public the benefits of their research work.

* * *

For years the Allison Brothers of Los Angeles have been doing consistently good work in school architecture. The Allison influence on school house design in California is manifestly apparent. Next month The Architect and Engineer will publish some recent examples of school work by these eminent architects.

* * *

Edwin Snyder has written a splendid article on the housing situation for this number of The Architect and Engineer. Turn to Page 25 and read what the Berkeley architect says about our housing shortage and how it is up to the architect to meet the situation.

PAINT WITH Cabot's Double White

It paints white and stays white . . . when applied to surfaces in proper condition Double White never flakes or chips . . . has a velvety texture, without the customary gloss . . . is unaffected by gases or light.

Double White is suitable for all kinds of surfaces—wood, brick, stucco, cement.

GUNN CARLE & CO.

20 POTRERO AVENUE
UNderhill 5480
SAN FRANCISCO



COMFORT WITH JOHNSON AUTOMATIC CONTROL plus QUALITY AND CLEANLINESS

"Quality + cleanliness + service = profits." That has been the "success equation" in the restaurant business. But now, "Comfort" has been added to the formula. Cooling in summer is demanded, more and more, by patrons everywhere. They insist upon being comfortable, in addition to eating good food in clean, attractive dining rooms.

No matter what type of air conditioning scheme is employed, a JOHNSON control system . . . automatic, efficient, reliable . . . can be adapted to fulfill every requirement of owner, consulting engineer, air conditioning manufacturer, and contractor. Many of the scores of devices in the JOHNSON "family" of temperature and humidity control equipment have been developed especially to solve air conditioning problems.

S & W Cafeterias are keenly alive to the importance of "patron comfort." Comprehensive air conditioning installations are an important part of the equipment in their dining rooms.

Johnson automatic temperature and humidity control systems in S & W Cafeterias:

- Charlotte, N. C. *Pictured at right, below.*
- Chattanooga, Tenn.
- Knoxville, Tenn. *Illustrated at right, above.*
- Washington, D. C.

M. E. Boyer, Jr., *Architect.*

Kirk Cousart, *Consulting Engineer.*



JOHNSON SERVICE COMPANY

Main Office and Factory Milwaukee, Wis.

Direct branches in all principal cities

A welcome new note in modern wall tiling

New 6x9 MASTER KRAFTILE

New Master Kraftile is a completely different wall tile that offers new possibilities in room decoration.

Laid either horizontally or vertically, these new six by nine units permit interesting variations in wall treatment.

With Master Kraftile, wall tile heights can be greatly increased without added installation charges.

Master Kraftile makes even the smallest rooms appear more spacious.

And a decided advantage over other large tile of similar shape lies in its architecturally correct size...the width in exact proportion to its length.

Specify new Master Kraftile for your next modern tile installation. Like all Kraftile, Master Kraftile is higher fired than other tiles, and cannot be sur-

passed for quality and hardness of glaze, or for durability.

Write today for specifications and samples. Kraftile Co., Niles, California.

See Sweets—Catalog 5, Section 11

Costs no more than a 4 1/4" tile installation

An installation of 6 x 9 Master Kraftile costs no more than 4 1/4" tiling. And costs approximately 30% less than other tile of similar large size.

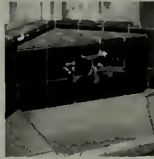

An unusual corner window and sink using Master Kraftile. Notice how easily and effectively this new 6x9 tile can be used for special corner situations

Write for free copies of this beautiful, descriptive booklet

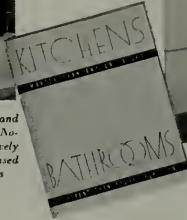

A strikingly modern Shower Room, circular in shape and set straight joint vertically with new Master Kraftile. An excellent example of many unique treatments possible to create with these 6"x,9" tile units



ANNOUNCING

MacDONALD HARDWARE MANUFACTURING CO.

NOW EXCLUSIVE MANUFACTURERS AND DISTRIBUTORS OF

• **DALMO
SIMPLEX
WINDOWS**

• **HAUSER
CASEMENT
WINDOWS**

• **KRAMER FLUSH VALVES**

MacDONALD HARDWARE MANUFACTURING CO.

ENGINEERED HARDWARE

963 HARRISON ST.

SAN FRANCISCO



Gas appliances ★
**ADAPT THEMSELVES TO
 INDIVIDUAL DESIGN**

GAS
 THE MODERN FUEL

SO flexible is modern gas fuel — so complete is today's line of gas appliances — that the architect's creative genius enjoys freer rein. ★ This hillside home, with far-flung rooms on different levels, would once have imposed a difficult, costly heating problem. Not now! Uniform comfort is assured by an inexpensive central warm-air gas furnace, automatically controlled. ★ The adaptability of gas extends even to interior design. Observe how the gas range not only harmonizes with, but actually decorates, this modern kitchen. ★ Hot water? Supplied by a "gas automatic" of course — with comfort, dependability and economy all in mind. ★ Gas is the architect's ally—both in creating ideas and in making loyal friends of his clientele!



**IDEALLY SUITED
 TO ENVIRONMENT**

Residence of Mr. and Mrs. A. M. Pilinsky, Oakland, Calif. ★ *Architect, Earl R. MacDonald.* ★ Special features include sunken patio, "glass garden," roof deck, recreation room and second-floor library in walnut.

COOKING • HEATING • HOT WATER

REFRIGERATION

FEDERAL ARCHITECTS SPECIFY CORROSIRON

● For drain pipes and fittings in new San Francisco Mint because CORROSIRON gives long life in contact with sulphuric, nitric and other acids and chemicals used in this building.



CORROSIRON is used extensively for acid drain lines in hospitals, universities, high schools, laboratories.

Send for latest bulletin with roughing in dimensions

CORROSIRON is manufactured by

PACIFIC FOUNDRY COMPANY, Ltd.

NEW YORK
551 Fifth Ave.

SAN FRANCISCO
3100 Nineteenth St.

LOS ANGELES
470 E. Third St.

Typical CORROSIRON installations—

University of California
California Institute of
Technology
St. Mary's College
St. Ignatius College
Oregon Agricultural College
San Jose Teachers College
High Schools in San Francisco,
Alameda, Oakland, Claremont,
Burlingame, Los Angeles,
Long Beach, Paso Robles,
Riverside, Seattle
Eastman Kodak Company
Pacific States Telephone Co.
Dairy Delivery, Acme
Engraving Co., San Francisco
Highland Hospital, Oakland
Folsom State Prison
American Can Company
Advertiser Building, Oakland
Goodyear Tire & Rubber Co.,
Los Angeles
Ford Motor Co., Seattle

CORROSIRON
MADE IN U.S.A.

**ACID PROOF
DRAIN PIPE
AND FITTINGS**



ASK YOUR CLIENT:

"Why get rustable pipe when Anaconda Copper Tubes cost hardly any more?"

Copper Tubes...*the outstanding "buy"*

for low-cost, durable piping

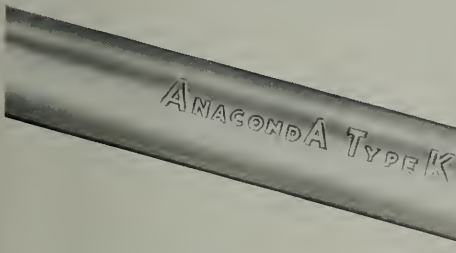

1. Anaconda Copper Tubes, assembled with "solder-type" Anaconda Fittings, cost scarcely any more than piping that rusts.
2. Copper Tubes eliminate rusty water and rust-repair bills for all time.
3. They not only last longer . . . they look better. Their sleek lines enhance the appearance of basement rooms.
4. Copper Tube *heating lines* are more efficient, give faster flow, cut the operating cost of a forced circulation heating system.
5. The Anaconda line of copper tubes and fittings is complete. Carried in stock by leading Pacific Coast supply houses. 3831



Anaconda DEOXIDIZED Copper Tubes

THE AMERICAN BRASS COMPANY • General Offices: WATERBURY, CONNECTICUT
In Los Angeles, 411 West Fifth Street . . . In San Francisco, 235 Montgomery Street . . . In Seattle, 1338 Fourth Avenue

World's Tallest Chimney



605 FT. STACK AT
SELBY SMELTING PLANT

AT THE Selby smelting plant near Martinez, California, the world's tallest smoke stack has recently been completed. The chimney is 605 feet 9 inches above the foundation, and is constructed of reinforced concrete.

The foundation, containing about 1021 cubic yards of concrete, was placed by continuous pouring in three days, using three eight-hour shifts.

It rests on hard, rock-like blue clay, which is good for 8000 pounds per square foot bearing area.

The shaft is designed to withstand the effects of acidic gases within and the combined loadings resulting from its own dead weight and a horizontal wind pressure of 100 pounds per square foot of projected area. Outside diameter at the base and top is 43 feet 11½ inches and 14 feet 8 inches; the thickness of the walls at both points is 25 inches and 7 inches respectively. The wall of the 5 foot crown shown in the halitone by courtesy of the Industrial Accident Commission, is 10 inches thick.

The shaft is connected to the base by means of 1 inch dowels, which start with hooks securely fastened

(Please turn to Page 60)

Colorful Bath Room

ROUND and roomy, an all-tile shower room adds a colorful and attractive feature to the new dwelling of the J. E. Crosbys situated in the growing section along the Tunnel Road, near the Moraga Road, in Alameda County, California. Planned by William Edward Schirmer, architect, of Oakland, the commodious bathroom off the master's bedroom is provided with the separate shower room. Behind a door of frosted glass, the single shower is a complete unit with its protected electric light and air circulation vent.

The use of the 9 x 9 size of tile for the walls of the shower room gives an effect at once smart and spacious. The angles formed by setting add to the neatness of design and break the monotony of the arc of the circular plan.

A special matching of color in the tiling was attained by C. W. Kraft who met the architect's speci-



SHOWER IS FINISHED
IN KRAFT "PEACHBLOW" TILE

fication for harmony with the bathroom fixtures. The tiling of the bath and shower rooms is in three shades of "peachblow," a warm and delicate color from the palette of a well-known maker of fixtures.

Carrying the lightest of the three shades, the shower walls are of semi-glaze 6 x 9 and are set vertical, straight joint. The darker hue of the "base board" is brought into the border of the tile flooring which is of 6 x 6 and of mat glaze finish. The square design centered in the floor is the darkest of the three shades and in coloring is close to "old rose."

The shower room is styled identically with the tiling of the bathroom and they make an unusually attractive combination.

EVERYONE NOTICES THE ENTRANCE



**CALL IN A DEPENDABLE METAL
FABRICATOR FOR THIS
IMPORTANT FEATURE!**

Architects depend on Kawneer, for entrances, as well as for all other types of architectural metal work; because the tradition of working closely with the architect is strong in the Kawneer organization; and because years of experience on important projects have taught Kawneer many things about the fabrication of metals for architectural uses.

Kawneer Rustless Metal DOORS are furnished in both welded-tubular and flush types, for all commercial buildings, and in connection with store fronts; in tubular and casement types for residential work; and to special details and specifications. Aluminum, bronze, nickel silver and other attractive and durable metals are employed. See SWEET'S for typical details or write The Kawneer Company, BERKELEY, CAL.



**STANDARD WELDED-
TUBULAR TYPES**

FOUNDED IN 1905—
BY A PRACTICING ARCHITECT

Kawneer

Rustless Metal Store Fronts • Doors • Sealair Windows • Architectural Metal Work

For data see catalogs in SWEET'S, or write The Kawneer Company, at Niles, Michigan, New York, Chicago, or Berkeley, Calif.

Dealers in principal cities.

PULSE OF THE READER

STUCCO PAINT

Dear Editor:

I have read with interest the article "Beware of Stucco" by William Carter Ree (Architect and Engineer for March) and most heartily agree with all that Mr. Roe has said. Furthermore I believe that any paint man who reads this article will feel as I do.

I have no thought that architects, worthy of the name, would specify products of this kind, but they might allow such products to be used.

If this article gets over, I am satisfied it will mean a saving of many dollars to prospective home owners.

Yours very truly,
FRANK W. DUNNE CO.
J. S. Reynolds,
General Manager.

Oakland, March 18, 1938.

MAGNESITE FLOORING

Dear Editor:

We would like to advise you that magnesite and composition flooring are the same, but in recent times, composition flooring is known to include mastic and asphalt tile.

Please therefore change your present listing of composition flooring to that of magnesite flooring and oblige.

Very truly yours,
MAGNESITE FLOORING
ASSN. OF SAN FRANCISCO
E. Castel, Sec'y.

San Francisco, March 11, 1938.

FIRST CERTIFICATE

Dear Editor:

I thought you might be interested in publishing some statement about Mr. Worsfold since he held the first certificate issued to any architect in the United States. This does not mean that he was the first architect, but that he was the first certificated architect.

I cannot say too much about his wonderful character and dependability. He at all times upheld the principles and ideals which he had pertaining to architecture.

He had been in my office since 1934 and helped a great deal on the work here with a sincere effort and determination at all times.

His knowledge of all the local ordinances was a great help to this office and I wish to express my gratitude for his splendid work while here.

Yours very sincerely,
HOWARD G. ELWELL.

Los Angeles, March 9, 1938.

ANENT GUARD RAILS

Dear Editor:

During the past several years complaints have come to this Department regarding the height of guard

rails around platforms and stairwells. Invariably these railings are less than the standard height called for by the orders of the Industrial Accident Commission. Where this condition is found the Commission orders a new railing installed at the proper height which is an additional expense and inconvenience to the owner.

We feel that if the architects' attention is called to the State's requirements on railings, the architects will be only too glad to cooperate and have the proper height railings installed at the time of original installation.

Here are the important requirements of General Safety Orders Nos. 12 and 13:

Order 12. Stairways—
(a) Where the stairway is not built next to a wall or partition, rails must be placed on both sides.

(b) If stairway is closed on both sides at least one handrail must be provided.

(c) If width is greater than four (4) feet, rails must be provided on each side.

(d) If width is eight feet or greater, rails must be provided on each side and in center of stairway, except in cases where in the judgment of the Industrial Accident Commission a center railing would be impracticable.

Order 13. Platforms and Runways—
(a) All elevated walks, runways or platforms, except on loading or unloading sides of platforms if four (4) feet or more from the floor level, must be provided with a two-rail railing not less than three and one-half (3½) feet high.

The above orders apply to any building where there are employees, except domestic help.

We would greatly appreciate any help you can give to publicity on these important safety standards.

Very truly yours,

L. K. REINHARDT,
Supervising Engineer, Construction Section.

ONE NATIONAL ORGANIZATION

Dear Editor:

In the January issue of the "October" will be found a timely contribution from Mr. Bergstrom, Treasurer of the American Institute of Architects, in which he gives a clear analysis of the prospects for business for architects during the current year and beyond. The picture is not very encouraging but I believe it to be accurate. Among other things, he points out the fact that architects have permitted without protest the setting up of bureaus within both local and Federal governments to perform architectural service, and have permitted banks, chain stores and other large establishments to perform similar service. It might be added that many producers of building accessories are doing much the same thing. There is not much left for the architect.

Mr. Bergstrom thinks that much of this work can be recovered for private practice if architects will unite, work

with their fellows to that end, and "stay united." This is a clear argument for the organization of a single national representative architectural organization.

The A. I. A. is the natural and logical nucleus around which such a single national organization, representative of all architects worthy the name in the country, can be organized if the A. I. A. earnestly desires such unification. In the past it has not. The present arrangement with state societies will not accomplish the result and is not enthusiastically endorsed by the state societies. Something more homogeneous must be adopted.

The Board of Directors of the Illinois Society have passed a resolution favoring the merging of the state associations and the A. I. A. under suitable conditions. If the A. I. A. will cooperate broadly, possibly Mr. Bergstrom's idea to "unite and stay united" might have some chance to be brought about. It will be some job however, for no two architects were ever known to agree!

VICTOR A. MATTESON,
Chicago, Ill.

UNFORTUNATE OVERSIGHT

Dear Editor:

I received The Architect and Engineer for March and regret exceedingly to find that I am not given credit for being the architect for the High School at Bellingham, Washington, on the page where the perspective of this building appears while you have put the name of the architect near all the other cuts.

Yours very truly,
LOYD A. NARAMORE,
Seattle, March 19, 1938.

CONTACT A RELIABLE MANUFACTURER

Dear Editor:

We would like to know what water-proof stucco paint you would recommend for re-painting stucco surfaces. Preferably not an oil paint.

Thank you for this immediate information.

Yours very truly,
O'CONNOR BROTHERS,
Clifford F. O'Connor,
Red Bluff, March 19, 1938.

NAME OF SCHOOL

Dear Editor:

The correct name of the school building which you illustrated on Page 40, March A. & E. is Rio Vista, not El Cerrito. Ches. M. Hutchison, architect.

W. E. P.
Los Angeles, March 15, 1938.

CERAMIC VENEER.

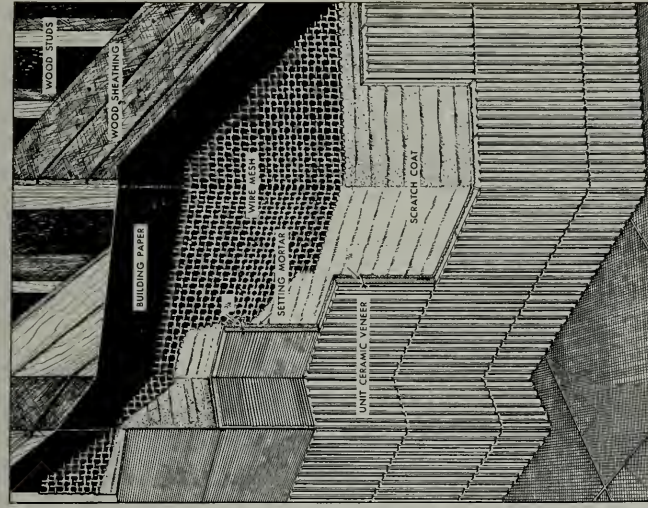

DETAIL OF TYPICAL SIMPLIFIED APPLICATION, BY THE ADHESION METHOD, OF UNIT CERAMIC VENEER ON BULKHEADS AND OTHER FEATURES, PIERS, SPANDRELS, AND ALL WALL SURFACES.

GLADDING, McBEAN & CO.



CONRAD BUILDING • LOS ANGELES • MARCUS P. MILLER, ARCHITECT
HERBERT M. BARUCH CORP., Gen. Contrs. • PHIL E. FRENCH CO., Setting Confr.



Your own
**GARDEN
 OF DREAMS**

Beauty you never dreamed your garden had is waiting the transforming touch of the right light.

When the soft darkness of night envelops your garden and blots out vistas, it gives an opportunity to create breathtaking effects by lighting only those things that contribute to the effect you wish to produce.

Favorite flower groupings, sundial, birdbath, pool, or fountain take on rare beauty and effectiveness impossible when daylight floods every flower, rock, and leaf alike.

Really enjoy your garden this summer. Light it for enjoyment during the refreshing summer evening hours that constitute much of the leisure of busy moderns. Light it so that you may enjoy its beauty from the windows of your home even during the "indoor" weather.

Booklets about modern garden lighting for all purposes will be sent without cost or obligation. Send the coupon now and plan your lighting for YOUR garden of dreams.

 Pacific Coast Electrical Bureau
 Department X 1
 447 Sutter Street, San Francisco

Please send me your free booklets on garden lighting.

Name

Address

City State

PACIFIC COAST
 ELECTRICAL
 BUREAU



Santa Fe Passenger Terminal, San Francisco

Building designed by
Engineering Dept.
SANTA FE RAILWAY CO.

M. C. BLANCHARD
Chief Engineer

H. L. GILMAN
Architect

P. J. WALKER CO.
Builders

WHITE & GLOOR
Terra Cotta Setters

Modern Transportation . . .

demands modern terminal facilities. From its new centrally located San Francisco passenger terminal, Santa Fe Railway carries travelers by motor coach over the new Bay Bridge to connecting main line trains, and by Santa Fe Trailways stages through to Eastern points. The structure is carefully planned to handle this heavy motor traffic and to afford every convenience and comfort to travelers. In keeping with its modern design and purpose the exterior is in **Ceramic Veneer** . . . Machine-made Terra Cotta produced by N. Clark & Sons, and presents a striking facade in modern line, texture and color . . . blue trim sets off a warm yellow-orange terra cotta.

A modern material for the new architecture . . . **Ceramic Veneer** is ideal for modernization of existing structures. We solicit your inquiry for samples and complete information.

N · C L A R K & S O N S
116 NATOMA STREET · SAN FRANCISCO
Portland · Salt Lake City · Los Angeles



DETAIL OF TOWER, ROSENBERG'S DEPARTMENT STORE, SANTA ROSA, CALIFORNIA
HERTZKA AND KNOWLES, ARCHITECTS

A SMALL-TOWN BIG-CITY DEPARTMENT STORE

By Fred W. Jones

OPTIMISM for the future of a growing community was largely influential in determining the scope of improvements following a disastrous fire in the Rosenberg Department Store, Santa Rosa, fifty miles north of San Francisco. Because of the city's close proximity to the metropolis of Northern California, it was felt that if the new store was to compete with its big town rivals, it must be up-to-the-minute in all departments, with facilities for handling all kinds of merchandise with the same speed and efficiency found in the metropolitan stores. To this end, Messrs. Hertska & Knowles, the architects, proceeded to plan along well-studied lines and the success of their efforts is reflected in the accompanying photographs and drawings.

Covering a ground area 150x100 feet, the Rosenberg building is a two-story structure, with illuminated tower, 100 feet high, discernable for miles. The building has a steel frame with reinforced concrete walls, stuccoed a light buff. Designed in the modern feeling for mass, simplicity and unbroken surfaces, the structure is outstanding as one of the best recent examples of this type of architecture in the West. Rounded corners add to the mass appearance and decorated lines in vertical and horizontal rhythm are cleverly worked out as an indispensable part of the ensemble. All metal work is satin finished bronze.

Two very striking features of the exterior have been made possible by the use of glass. One is the steel tower, enclosed with sheet

metal and glass, and illuminated at night in light blue. The other feature is a glass brick grille over the main entrance that not only adds a decorative note to the exterior but supplies a vast area of light within. The grille is the first one of its kind, that we know of, where curved sections in such a large area are used. Show windows along the two street frontages present an unbroken glass front. The background of these windows is simply treated with canvas painted a light buff.

One of the main problems entering into the design of the building was to create a new shopping center some distance from the former location. This was accomplished by introducing the unique features already referred to and also by providing six additional store units on the main street which may be used by the department store for future expansion. In the rear of these stores free parking space is provided. Still another feature introduced by the archi-

*Photo by
Bartlett*

Night View,
Rosenberg's
Department
Store,
Santa Rosa,
California





MECHANICAL FLOOR PLAN



SECOND FLOOR PLAN

PLANS, ROSENBERG DEPARTMENT STORE, SANTA ROSA
Hertzka and Knowles, Architects

fects is the setting back of the bearing columns in the show windows so as to give an unbroken view.

The interior of the store was planned to give as much light and airiness as possible to create a feeling of warmth and friendliness. Modern ideas of space and arrangement have been adopted throughout. The main aisle is fourteen

feet wide with bargain squares in double "U" shape down the center. Cross aisles of equal width have rows of display tables 2 1/2 x 5 feet, placed crosswise and providing liberal space for merchandise display. All wood work on this floor is oak. High base show cases are used for display on the corners. Bronze metal work, cream walls and asphalt tile floor in tans and

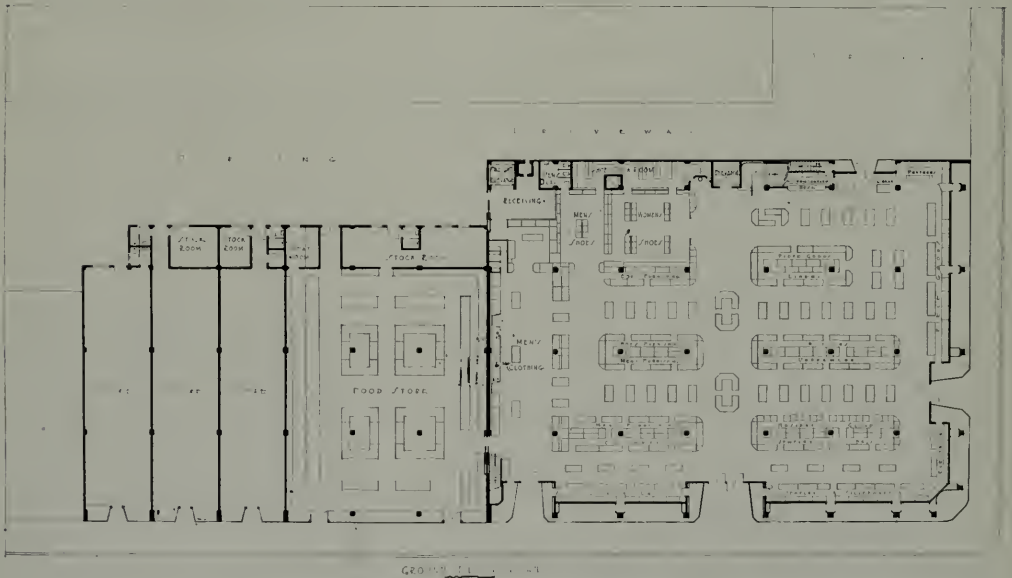

GROUND FLOOR PLAN

FIRST FLOOR PLAN, ROSENBERG'S DEPARTMENT STORE, SANTA ROSA
Hertzka and Knowles, Architects



Moore and Roberts, Builders

ROSENBERG'S DEPARTMENT STORE, SANTA ROSA, CALIFORNIA
Hertzka and Knowles, Architects

ROSENBERG'S DEPARTMENT STORE
Santa Rosa - California

Architects: Hertzka & Knowles.
Structural Engineer: W. W. Breite.
Mechanical Engineers: Leland & Haley.

CONSTRUCTION OUTLINE:

FOUNDATION	Reinforced concrete
STRUCTURE	Steel frame
EXTERIOR	
Walls	Reinforced concrete; cement plaster
Roof	Johns-Manville asbestos built-up roof
Sash	Michel & Pfeffer steel sash; glazing by W. P. Fuller
Doors	Mahogany and plate glass; Richmond fire doors to food store and freight entrance
Tower	Steel frame covered with sheet metal and glass
Awning	Disappearing type awning
Bulk Head	N. Clark & Sons unit tile
Glass Brick	Entrance and clerestory for first floor Libby-Owens-Ford glass brick
Marquee & Tower Lighting	Electrical Products Company's Lumenac

INTERIOR

Floors	First floor, concrete with Moultilite asphalt tile; Mezzanine, solid wood laminated floor with Armstrong's linoleum; Second floor, solid wood laminated floor with D. N. & E. Walter's carpet
Stairs	Wood stairs with Armstrong's linoleum and safety stair treads
Walls	Plaster painted with Fuller's lead and oil paint
Elevators	Olis Elevator Company
Insulation	Reynold's metallation type B over roof trusses
Waterproofing	Dehydratine on inside of concrete walls; Kon-set on outside
Heating	Ray oil burner
Ventilating	Forced air system with American Blower Company fans
Lighting	Curtis Lighting Company fixtures
Plumbing	Kohler fixtures
Store Fixtures	Weber Showcase & Fixture Company
Pneumatic Tube System	Lamson Company
Sprinkler System	Fire Protection Engineering Co.

A Small-Town Big-City Department Store

ROSENBERG'S, SANTA
ROSA, CALIFORNIA

Hertzka & Knowles,
Architects



Photos by Kerrigon

Above—Shoe department
—open privacy has been
accomplished here with a
low oak paneled screen.

Left—Millinery, ready to
wear and suit department,
second floor.

Right—Beauty shop. Typical of semi-shop
plan on second floor. Painted ply-wood
finish, indirect lighting fixtures, rust colored
carpeted floor.





PART OF FIRST FLOOR AND MEZZANINE, ROSENBERG'S, SANTA ROSA
Hertzka and Knowles, Architects

browns complete the scheme of the main selling area. Lighting is handled by indirect hanging fixtures of metal. The first floor fixtures are purposely kept below the normal eye level so as to provide an unbroken view of the whole floor.

The second floor was planned to give a semi-shop appearance. Display of baby articles, sport goods, etc., is given individual space on this floor by open shops as shown in the photographs.

W. W. Breite was the structural engineer, Leland & Haley designed the mechanical equipment and the Weber Show Case & Fixture Company collaborated with the architects on the fixture work.

The building is heated and ventilated with the latest equipment and is equipped throughout with an automatic fire sprinkler system and electric elevators.

F.H.A. DOCUMENTS FOR ARCHITECTS

May be had on application to the Los Angeles or
San Francisco Insuring Offices

Minimum Construction Standards.

General Property Standards, Circular No. 2.

Local Property Standards, Circular No. 2, Part VI.

Recent Developments in Dwelling Construction. Technical Bulletin No. 1.

Modern Design. Technical Bulletin No. 2.

Contract Documents for Small House Construction. Technical Bulletin No. 3.

Principles of Planning Small Houses. Technical Bulletin No. 4.

Planning Neighborhoods for Small Houses. Technical Bulletin No. 5.

Multifamily and Group Housing Insurance. Regulations under Sections 207 and 210, National Housing Act.

MATCHLESS VIEW OF SAN FRANCISCO LURES

THE "SKYROOM" ATOP HOTEL EMPIRE

Douglas Dacre Stone, Architect—

Lou B. Mulloy

Hertzka & Knowles

Associate Architects

TWENTY-FOUR stories from the ground, offering a superb—almost breath-taking view of San Francisco and surrounding country, the Sky Room of the Hotel Empire, formerly the Hotel William Taylor, is San Francisco's newest, most unique cocktail bar—unique, indeed, because it has no prototype west of New York. Facing the cardinal points of the compass, the room tops the roof lines of neighboring skyscrapers, its great 6x14 foot windows a lure to the visitor to gaze without and behold a picture of surpassing beauty. At night the view is even more enchanting with myriads of vari-colored bulbs twinkling in the distance, searchlights throwing their beams across the heavens and down the street fascinating blotches of red, green and blue Neon.

Equivalent to six or more floors above the Sky Room is a new airplane beacon for the Civic Center—a Neon sign made of 14-foot letters and equipped with a special fog-piercing illuminant visible for miles.

Originally the Empire Hotel's twenty-fourth floor Sky Room space was devoted to two apartments, later to be transformed into two separate bars. Due to numerous partitions, the view was limited and the circulation poor, so the entire floor was rebuilt, the construction work handled by Lindgren & Swinerton, Inc.

The Sky Room Lounge was designed and planned by Douglas Dacre Stone, architect,



PUBLIC TO NEWEST COCKTAIL LOUNGE

Lou Mulloy and Hertzka & Knowles, associate architects. Between each window there was formerly a false column which was removed to give increased window space. The steel sash was made as wide as possible and divided within the maximum limits to allow for washing. There is a pocket at the head of each window for drapes and Venetian blinds, so when the blinds are not in use they are invisible. A bronze rail affords security without impairing the view.

Pipes, conduits and ducts are grouped in minimum space and at points where they do not interfere with the plan of the room. The mirrored column in the center of the bar contains many of these ducts.

The island bar, installed by William Bateman, has a gold front. The bar top is walnut Lamicoïd—alcohol and cigarette-proof. There are four main stations, or set-ups to the bar, including one for table service. The bar interior, being visible to the customer, care had to be taken to make the set-up as attractive as possible. All of the metal work is stainless steel and the entire section below the worktop is enclosed in walnut veneer. The installation of metal work was made by the Barthold Soda Fountain Company.

Everything in the room was especially designed, there being not a single "stock" item.

In the center of the room is the elevator and service island. There are two passenger elevators, one freight elevator, stairs and men's and women's lavatories. The island is finished with figured walnut flexwood. Exterior walls and ceilings are canvas with walnut trim. A radio system, including speakers, is concealed, with outlets placed at strategic points.

The main source of light is from an indirect





ISLAND BAR, THE SKY ROOM, HOTEL EMPIRE, SAN FRANCISCO

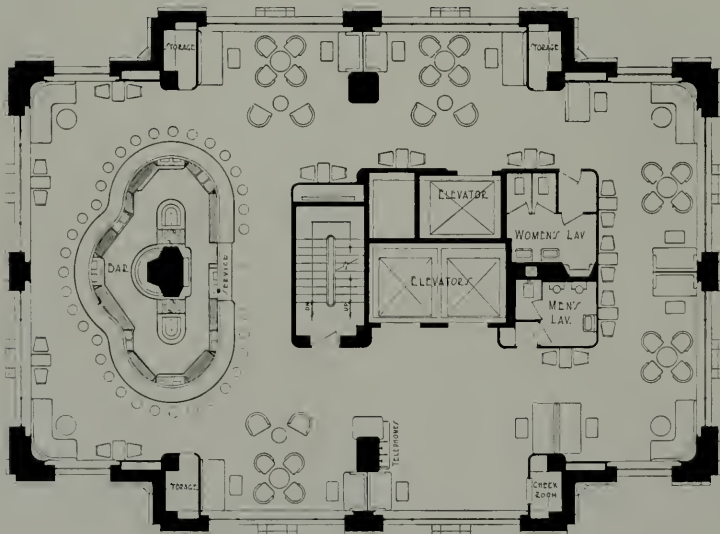

THE SKY ROOM
 TWENTY-FOURTH FLOOR-HOTEL EMPIRE
 SAN FRANCISCO



PLAN, THE SKY ROOM, HOTEL EMPIRE, SAN FRANCISCO



LOUNGE, THE SKY ROOM, HOTEL EMPIRE, SAN FRANCISCO
 Note View of City and Bay Bridge

cove over the bar and around the elevator island. The problem was to provide not only the most flattering light for the women patrons but to furnish adequate artificial light and at the same time avoid reflections on the windows at night, which would destroy the view. This

was accomplished by ingeniously placing the source of light in the cove behind the spectators. Over each window there is a combination light and exhaust grill fixture mounted flush with the ceiling. A forced air ventilating system is included in the equipment. F.W.J.

SKY ROOM, HOTEL EMPIRE, SAN FRANCISCO

Architect: Douglas Dacre Stone; Lou B. Mulloy.

Associate Architects: Hertzka & Knowles.

CONSTRUCTION OUTLINE:

EXTERIOR WALLS Metal lath and plaster with canvas

ELEVATOR ISLAND Walnut Flexwood

Floor Bigelow-Sanford carpet
 Sash Soule Steel windows; glazing by W. P. Fuller
 Doors Walnut veneer flush doors

BAR

Woodwork William Bateman Co.—Walnut veneer for service cases; Poplar veneer on bar front sprayed with gold lacquer

Bar Top Walnut Lamacoid by Dalmo Mfg. Co.

Stainless Steel Barthold Soda Fountain Company

Metal Work

Furniture Manufactured by S. Brown & Co.

Heating and Ventilation Forced air system by Cochran & St. John

Lighting Zeon cove lighting; special fixtures by Preston Hopkins

Bronze Work McNeill-Steinberg Co.

Radio Stromberg-Carlson by Walter Brown

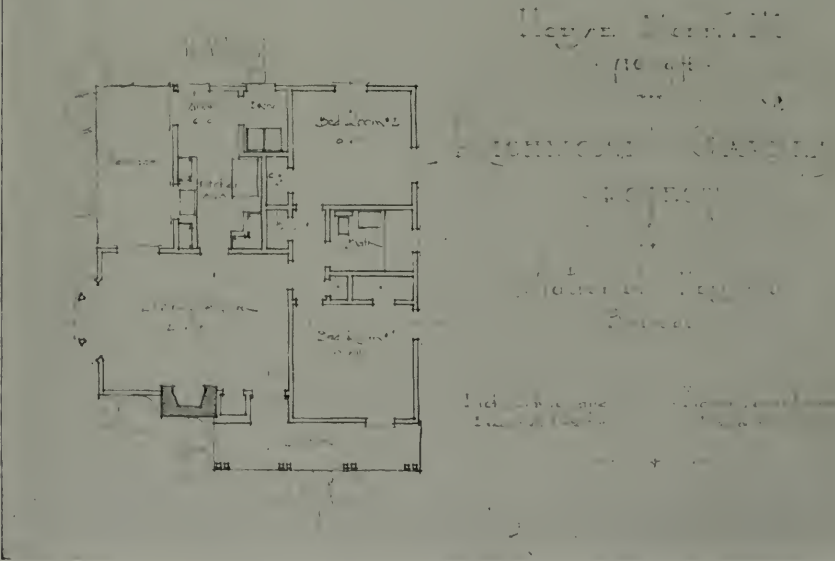

MODEL A, RICHMOND GARDEN PROJECT, NATIONAL HOUSING BUREAU
 EDWIN LEWIS SNYDER, ARCHITECT

HOUSING SHORTAGE IN CALIFORNIA AT CRITICAL STAGE

By Edwin Lewis Snyder, Architect

BOOKS have been written, magazine articles by the hundred have been published, newspapers have consumed countless thousands of columns concerning low cost housing. Lectures have been given, radio talks sent over the air, speakers have harassed the Congress, millions of dollars have been spent and the low cost housing problem has not yet been solved.

Why? Because, in spite of all the work done in this field in the past, in spite of all the cheap construction thrown on the market by poor speculative builders, in spite of repeated attempts made by architects to design small homes, all costs are still too high. Too high, because 65 per cent of the people in the United States earn less than 1650 dollars per year. Included in this 65 per cent are, 10 per cent who earn \$550 or less—30 per cent who earn \$1100 or less—25 per cent who earn between \$1100 and \$1650. This 65 per cent of our population constitutes over 19 million families and includes those who have not been able either to purchase or to rent suitable shelter at a price consistent with their income, because there have been none available.

Recent amendments to the Federal Housing Act have made it possible for many of these families to borrow money easily, for the purchase of homes. But it is impossible to find homes to meet the requirements. And what are these requirements? First of all, compactness

—the elimination of all unnecessary circulation, and this to be obtained without sacrificing livability—one of the most important and also one of the most illusive qualities of small house design. Then the structure must be soundly built, of first class materials and workmanship. Nothing shoddy or makeshift must be permitted to enter this type of construction, for remember, after the 20 or 25 years of amortization, there must still be a home left. Added to this sound construction must be the element of good design. And here the architect is of paramount importance, for without this quality, all the foregoing is of little value. To obtain this architectural feature it would be of great value to this whole problem if these small houses could be built in groups, in which a definite design could be established and an entire tract developed in pleasing harmony and artistic value.

As an example, witness what has been done in the restoration of Colonial Williamsburg and how that restoration has influenced and will continue to influence residential development along the entire Atlantic coast.

Thought must also be given to such spiritual qualities as proportion, mass, composition and the like. There should be no crowding together, but plenty of light, air and sunshine made available as a direct contrast to our wretched tenement and slum districts, where disease and crime find a fertile field for growth.



MODEL B, RICHMOND GARDEN PROJECT, NATIONAL HOUSING BUREAU
EDWIN LEWIS SNYDER, ARCHITECT

And with all the foregoing and perhaps first in importance in the solution of this low cost housing problem, must be standardization and volume, for it is only by standardization and volume that low costs may be realized. By standardization is not meant standardization of design, which would be fatal to good architecture, but standardization of elements—such as, size of rooms, height of building, length of studs and joists, size of doors and windows, arrangement of kitchens and bath rooms, kinds of materials, types of heating, types of plumbing fixtures, etc. A standardization of these elements, coupled with volume, will speedily bring the cost per unit down to as much as 20 per cent below prevailing costs.

It was with these important facts in mind that the writer was called into conference with a group of individuals determined on finding a solution for this problem of low cost housing. The outcome of that contact was the four designs illustrated. These designs are titled Models "A," "B," "C" and "D."

Model "A," a four room dwelling containing 710 square feet, consists of living room, kitchen with nook, two bed rooms and bath. This model, built on a \$500 lot, will sell for approximately 20 dollars per month under the revised FHA plan. Models "B" and "C," each five room schemes and containing 890 and 886 square feet respectively, will sell for approximately \$25 per month. Model "D," a six room scheme, containing 1075 square feet, will sell for approximately \$28 per month.

These four model plans were arrived at only after much deliberation and thought and after several years work in an endeavor to reach a solution of the architectural contribution to the problem of low cost housing. Architects in both the southern and northern part of California were called into conference and the four plans are a composite of all ideas contributed to the general idea of this national problem. While all design is flexible and subject to almost endless change, these four plans must be used as illustrated, the hope being that in this standardiza-

tion without any possibility of costly changes, the low costs will be maintained.

At this point it might be interesting to delve somewhat into statistics and see just what the demand for low cost homes is throughout the country. We all know that through Federal inspiration and newspaper publicity, the entire population has become housing conscious, but just how great is the need can only be measured by figures.

The government advises that we have built short 6 million homes during the period 1930-37.

There are now in the United States 6 million buildings, housing one or more families, which are unfit for human habitation. They breed crime, disease and juvenile delinquency.

There is an average increase in the population of the United States of about 12 million persons for the ten year period, or over one million per year.

There are about one hundred thousand homes destroyed by fire each year.

There are approximately one million marriages in the United States each year.

Analyzing the above figures shows that a total of 1½ million new homes per year is needed in the United States, exclusive of the shortage of 12 million homes due to obsolescence and lack of building. It is estimated by the building industry that by 1940 we will have a shortage of 14½ million homes. In addition to this need for new homes, statistics show that in existing homes—

- 42.7 per cent do not have heat
- 23.3 per cent have no tubs or showers
- 17.2 per cent do not have sanitary plumbing indoors
- 33 per cent do not have hot water supply
- 8 per cent have neither hot or cold running water
- 25.5 per cent have neither gas or electricity
- 9.5 per cent do not have electric lights

(Please turn to Page 44)

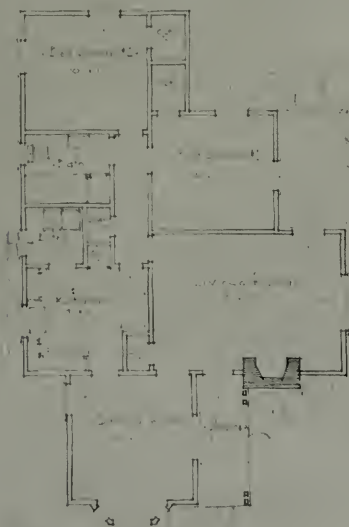

Model C
- 440 sq. ft.
1935
National Housing Bureau
Edwin Lewis Snyder, Architect

MODEL C, RICHMOND GARDEN PROJECT, NATIONAL HOUSING BUREAU
EDWIN LEWIS SNYDER, ARCHITECT

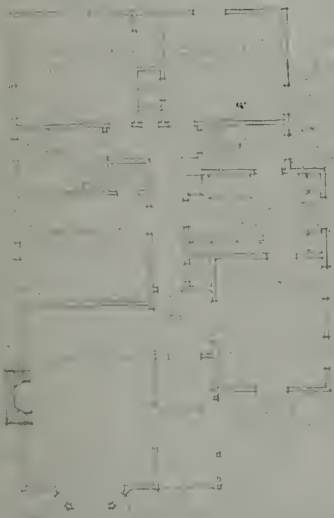

MODEL D, RICHMOND GARDEN PROJECT, NATIONAL HOUSING BUREAU
EDWIN LEWIS SNYDER, ARCHITECT



RESIDENCE FOR MAJOR HARRY L. TOPLITT, WEST LOS ANGELES
H. ROY KELLEY, ARCHITECT

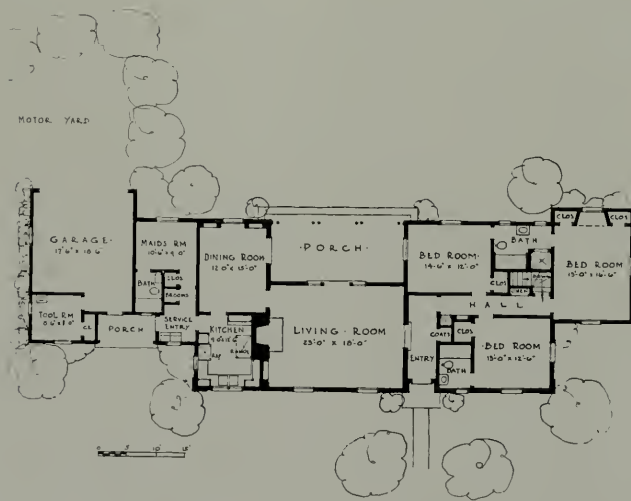

RESIDENCE FOR
MAJOR HARRY L. TOPLITT.
WEST LOS ANGELES, CALIF.
H. ROY KELLEY, ARCHITECT.

PLAN, RESIDENCE FOR MAJOR HARRY L. TOPLITT, WEST LOS ANGELES
H. ROY KELLEY, ARCHITECT

"MEN IN SMOCKS"

PROPOSING A MOVING PICTURE WITH ARCHITECTURAL BACKGROUND

Some prominent architects in the East recently started agitation for the production of a moving picture with architectural background, like the medical profession was publicized in "Men in White." The Bulletin of the Michigan Society of Architects, seeking the reaction of the cinema industry on the possibilities of such an undertaking, publishes the following interesting and informative reply by Stephen Goosson, Art Director in Chief of Columbia Pictures Corporation, and a former Detroit architect:

"Men in White" was a perfect picture, a big money maker, superbly cast and directed. Pictures like that are not made every day. It was just one of those things that happened. Its cost was over a half million dollars, and it returned twice as much.

Paul Kasurin hinted that a group of you may get together and write a story around the office of an architect. The idea sounds interesting, but you are faced with a difficult problem. Exhibitors are reluctant in accepting a picture which smacks of propaganda. They feel they ought to be paid to run the stuff, instead of paying for it. On the other hand, if the story is cleverly written, you might interest one of the studios. Your first problem is the release—next, the money—the story—the cast.

"Men in White" had Clark Gable, a superb actor. Clark, in any picture, would be a success—"he's the picture." When "Men in White" was made his salary was around five thousand a week. It's twenty-five thousand now, with a four-week guarantee. The director's salary would figure about fifty thousand. The balance of the cost, depending on your story, could be any amount.

You will learn one thing—and that is it's expensive to make a picture. The whole thing is a gamble. I have been identified with nearly eight

hundred pictures and have seldom seen one of them within its budget.

I have read stories which sounded as if they would be terrific successes, that finally turned out to be our biggest flops. You never know what you really have until it's cut and edited.

Mr. Frank Capra, our ace director, has been most successful—he has a magic touch. When Frank put Clark Gable in "It Happened One Night," Clark was furious. He said the story was bad, and what he said further would not be fit to print. Clark, at that time, was in the dog house with M.G.M. and on the down grade. Frank persuaded him to forget it, and Clark consented. That picture won the Academy Award, both for Clark and Claudette, and for Mr. Capra. Little did anyone know that it was going to bring in a million dollar profit. So it is with pictures, but don't let me discourage you. After all a few pictures are successful. If they were not, Columbia would go out of business.

I would like to have you bear in mind a few things. Be prepared to have a bag full of money. Select a cast that will draw at the box office; get a writer and director who know what they are doing, and last, and very necessary, let the man who knows how "do it for you." Hollywood is filled with rocking-chair producers, directors and writers, but few are capable of making anything except a lot of talk.

Since writing to Paul, the idea for a story came to me, which might be worked out—anyway, it will start the ball rolling in the right direction. Here it is:

I'm using the contractor as the villain, the high pressure type, a fast talker and a shyster at heart. We will call him Mr. Shyster. He makes plans, specifications, does the financing and construction. His plans are filled with loopholes. He gets the owner's name on the con-

tract and wiggles out diplomatically on his promises, causing a lot of extras. He appears very sorry about all these extras, but to show his heart is in the right place, offers to put them in at cost, then charges double.

Now, to go on with the story:

Mr. and Mrs. Ames have saved all their lives for a little home of their own. Marguerette, their daughter, urges them on. She is ashamed of her present surroundings, since now she is a junior in college and is beginning to entertain her boy friends. Up until now they really couldn't afford a house, but now with the F.H.A. it's going to be easier. It won't take so much of their cash. Some one at the factory suggested Mr. Shyster's name (this someone may be getting a cut-in). Anyway, Mr. Shyster's name appears in front of two or three houses being built in the new neighborhood, so Mr. Ames comes to the conclusion he is all right.

Mr. Shyster appears, after a phone call, with a group of blue prints and a few sketches, more or less of the home-made variety, badly designed, but beautiful in the eyes of Mrs. Ames. She doesn't read blue-prints and leaves that part of it to Mr. Ames. Mr. Shyster is very happy that she likes the perspective, as half the battle is now won. They sit down together and spread them all out on a table and while they are going over them, Marguerette appears from out of her room, in evening clothes.

Her mother looks up, startled, and says in a voice which sounds very much like the villain of an old-fashioned melodrama, "You're going out again tonight?"

"Yes, mother. Now don't get excited about it. It's only to the J-Hop. Don't you remember." Her mother doesn't but that's neither here nor there. Marguerette will have her way. She is beautiful and desperately spoiled, but withal exceedingly popular amid the younger set. Her boy friend appears, all dressed in tails and with a happy-go-lucky smile, but at the party he ditches her, after a quarrel, for another. The hour is late and she is desperate. Her mother will be worried. Off in the distance she sees Jerry Wadsworth, a senior. She never cared very much for him, always thought he was too

studious, but why be particular at this hour when she ought to be home? She rushes over to him, "Why Jerry, hello, how are you?"

He's not sure how to take this greeting. He glances around to see if there is another Jerry. Not seeing anyone he turns to her; his face is flushed.

"I'm so glad to see you," she adds. "Are you alone?" Of course he was. She knew that and she also knew that Jerry liked her a little. Women have a way of finding out. He beamed from ear to ear when she suggested that he take her home. Would he take her home? Just try to stop him.

"I'll show you how to get there. Our home is not much to look at, but father is going to build a new house."

"Are the plans made? You know I'm a senior in architecture," he tells her.

This is to be the beginning of a very fine friendship, and should be developed to a point where she believes in him and his future as an architect.

"You ought to have an architect," she suggests to her father. "That won't be necessary. Mr. Shyster's plans are good enough for me, and in addition, think of all the money we save."

"But father, Mr. Shyster doesn't work for nothing, does he? Doesn't he have to pay someone for the plans?" The father is satisfied, but Jerry is skeptical when he overhears Mr. Shyster say, "Why go to the F.H.A.? That's an added expense. Let me finance it. You pay me what you have and I'll take a trust deed, then you pay me so much a month." Jerry is listening, turns to Marguerette and whispers, "He doesn't want the F.H.A. because he's afraid they will check his plans. I tell you, Marguerette, we've got to get those plans and check them ourselves before it's too late. I've got an architect friend down town who will be glad to go over them with me."

Early the following day we find Jerry in the friend's office. Marguerette sits close by watching the two men go over each detail carefully. She likes the way Jerry goes about it. She

doesn't take her eyes from him. Right now she is secretly hoping that he really likes her.

In Mr. Shyster's office, we see him sitting back in his chair. "Yep, it's a cinch, we've got Ames hook, line and sinker. He'll sign this afternoon. I'm to meet him in an hour."

Cut back to the architect's office. They are just finishing. Jerry is on the phone checking Mr. Shyster's references. His collar is open, his coat is off, and he appears to have had a busy day. He hangs up and turns to Marguerette. "That guy's a gyp. What's your house number. I've got to tell your father some of the things I've learned before it's too late." Marguerette stares at him in anticipation, while he dials her number. It's busy. Ten minutes later, it's still busy. "We've got to get him, we're wasting time." Jerry, the architect and Marguerette rush out. The elevator is too slow, down the stairs they go as if the building were on fire. Marguerette is out ahead.

Cut back to the house. Mr. Shyster is there. The contract is spread out on the table. Mr. Ames is accepting Mr. Shyster's pen. "It's going to be a beautiful house," Mr. Shyster assures him, "the finest in the neighborhood." Mr. Ames nods and smiles. Mrs. Ames stands by anxiously.

The car is racing through the streets. A red signal stops them. "Oh why can't we go right through them? We've got to get there." They're off again — twenty-thirty-forty-fifty miles. Suddenly a siren is heard, and a cop appears on a motorcycle, beckoning them to one side. "Please, officer, we've got to make it," they plead for no delay. "Come with us, we'll prove to you we're telling the truth. There's a crook at our house."

"A crook?" The officer's eyes bulge out. "Let's go," he says, "I'll lead the way." They go through the streets with police escort and siren shrieking.

Mr. Ames has pen in hand. They're laughing heartily. He sits down. "Now, where do I sign this thing?" He's about to sign. His glasses—"Oh yes, Mama, get the glasses."

Coming down the street with siren shrieking are Gerald, Marguerette, the architect and the

cop. In front of the apartment they all jump out. The cop follows — up the stairs, around and around.

Mrs. Ames appears with the glasses and helps Mr. Ames. He glances over the contract. Mr. Shyster points to the dotted line. Out in the hall the group are rushing to the door. They ring the bell, kick the door frantically. Mr. Ames looks up. "Who might that be, Mama, has somebody gone crazy?" She goes to the door, while Mr. Ames leans over to sign. The door opens and they all rush in. "Don't sign that paper, Daddy," Marguerette cries out. Mr. Ames looks up, "Why, what's the matter?"

"That man is a crook," she yells. "We've got enough on him to put him in jail." Mr. Shyster crouches away. Gerald walks in, and explains quickly, then introduces his architect friend. The story ends with Jerry and Marguerette sitting on the couch together in the living room and at one side Mr. Ames and the architect blocking out a new floor plan. The end.

There you have it, very roughly done. Let's have some more of them.

* * *

Commenting on Mr. Goosson's letter the Bulletin says:

"What we do firmly believe is that if the architects have a story worth while the telling of it should cost them nothing, since it will be a money maker for the producers. If they have not such a story no amount of money will make it worth while. We further believe that the story of architecture does have much of the dramatic, of romance and human interest, just as does the medical profession.

"We emphasize the suggestion made by Mr. Goosson that architects contribute to this idea, 'The Story of Architecture.'"

From Washington, headquarters of the A.I.A. comes a forceful word from the Executive Secretary, Mr. Kemper. He says:

"At least once a year some one seriously proposes that The Institute sponsor and finance a moving picture based on the service of the Architect—but they overlook two items which seem to Mr. Goosson to be essential—namely, a story, and a lot of dough."



RESIDENCE FOR MR. AND MRS. EDWARD
MADDOCK, SAN MARINO, CALIFORNIA

H. ROY KELLEY, ARCHITECT

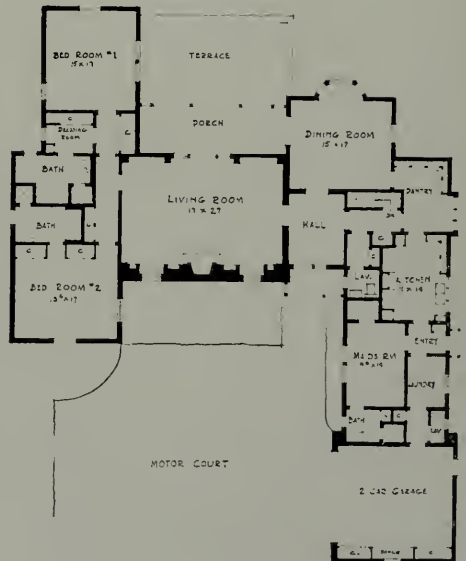

MODERNIZATION CREDIT PLAN

By C. A. West,

Assistant to the Director, Federal Housing
Administration, San Francisco

THE improvement and repair of residential, commercial and industrial properties now may be financed by FHA insured loans under the recently enacted amendments to the National Housing Act.

Although the Federal Housing Administration does not lend money for this, or any other purpose, revival of Title One of the Housing Act, known as the Modernization Credit Plan, permits the insurance of loans made by approved private lending institutions for purposes other than home financing. The new plan is divided into three general classifications.

Class One provides for the insurance of loans up to \$10,000 to repair, alter or improve existing structures. The loan is repayable in monthly installments over periods not exceeding five years, at a rate not in excess of an amount equivalent to \$5 discount per \$100 original face amount of a one year note.

Types of existing structures which may be modernized under this plan include homes, apartment houses, multiple-family houses, hotels, office or other commercial buildings, hospitals, orphanages, colleges, schools, churches, manufacturing and industrial plants, and any other similar completed structure having a distinctive functional use. The improvements may be structural, or for the purpose of purchasing and installing equipment which becomes a permanent part of the property, or for the construction of built-in fixtures and conveniences in a home. Loans to finance the cost of painting an existing structure, putting on a new roof, installing a new bathroom, and similar types of work, are clearly eligible.

A loan to convert one type of building into a different type will be eligible for insurance, pro-

vided a substantial part of the original building is left standing. For instance, a loan for the conversion of an old single family dwelling into an apartment would be eligible, if walls and other main structural elements were undisturbed. A new stairway, new windows, rooms, porch, etc., may be added, and partitions changed. It would not be possible, however, to demolish an existing structure and erect a new one, nor would a loan for the purchase of detachable equipment be eligible for insurance.

Class Two covers loans up to \$2500 to erect structures exclusive of those used wholly or in part for residential purposes. The terms are the same as for Class One. Types of structures eligible, to be erected on improved or unimproved real estate, include barns, garages, service buildings of various types, wayside stands, gasoline stations, tourist cabins, and various industrial or commercial buildings.

To be eligible for insurance under this classification, a new structure loan may not include the cost of equipment used in the productive process of the occupant. The loan may include the cost of heating or lighting systems and similar items which are considered as eligible under Class One improvement loans. For example, a loan not in excess of \$2500 may be used to erect a gasoline station, including a heating system, but no portion of the proceeds may be used to buy and equip the structure with pumps, hoists, grease guns and other productive equipment, nor may any portion of the proceeds be used to purchase the land. However, an eligible loan may include the cost of architectural and engineering services.

Class Three in the Modernization Credit Plan group provides for insured loans up to \$2500

to erect new structures used wholly or in part for residential purposes. The borrower may repay in equal monthly installments over a convenient period not to exceed ten years, on terms not in excess of an amount equivalent to \$3.50 discount per \$100 original face amount of a one year note.

On loans under this classification, security will be required in the form of a mortgage or deed of trust covering the property improved. In addition, there will be certain general construction requirements to assist in protecting the investment of the home owner.

The provision for constructing homes under this plan should not be confused with home ownership under the Federal Housing insured mortgage system, the long term plan of home financing. New homes constructed under Class Three of the Modernization Credit Plan are intended primarily for those who live on farms, in rural areas, or in the marginal zone surrounding the larger cities where standards established for the insured mortgage system are not applicable.

CONSTRUCTION REGULATIONS

Following are the F. H. A. requirements for applications on new construction or "additions and alterations," San Francisco insuring office; ARCH. SECT. BULLETIN NO. 6, REVISED JUNE 9, 1936.

I. Applications for insured loans will be made on forms provided in quadruplicate, two for the Federal Housing Administration, one for the mortgagee, and one for the applicant. In space provided, show the lot with dimensions and distance from block corners, write in names of streets and answer questions regarding paving on all sides of block. Two photographs of the site are required to be attached to all four copies of application.

II. For new construction three full sets of plans and specifications are required. Each set should be signed by the borrower and contractor for identification. One set is for the mortgagee, one for the permanent files of the F. H. A. and one for the use of the F. H. A. until the work is completed and insurance policy issued. They may then be returned, but the Federal Housing Administration reserves the right to retain them. The plans and other drawings submitted should be blue or other prints from tracings. Specifications must be type-written.

III. It is necessary for plans and specifications to

be sufficiently complete to describe fully and set forth in detail the proposed building so that an accurate estimate may be made and completed building checked against the plans and specifications. These plans and specifications will include and show:

1. Plot Plan with dimensions and shape of the lot, size, location and area of building, with dimensions: walks, roads and permanent landscaping features, legend showing square foot areas of lot and building, with percentage of lot coverage.

2. Floor plans, including footing plan and details, basement and roof plan. All four elevations, Sections and Details sufficiently complete to indicate clearly the extent of the work and the design and construction. Elevations may be $\frac{1}{8}$ " scale, provided that Details are adequate. There should be at least one complete wall section, preferably at $\frac{3}{4}$ " scale. The Specifications should completely cover quality of materials, equipment, construction and workmanship.

NOTE: Failure to supply complete plans and specifications will cause unavoidable delay, owing to the necessity of obtaining full information as to the exact intentions of the borrower with regard to character of the proposed building. Failure to supply complete information may result in ratings lower than might be justified by the intentions of the borrower and builder, and may entail reduced valuation.

IV. Accompanying each application for new construction must be the name of the Architect, if any, and the name of the contractor or builder, with low competitive bonafide signed bid or signed contract which is acceptable to the owner. If owner intends to build without competitive bids or to have the house built by his own forces or on a cost plus basis, one copy of a segregated summary of cost is required. If there is any revision, before or during construction, which reduces the cost or materially changes the house, the insuring office should be advised in full by letter with two copies of drawing and specifications of change.

G. F. ASHLEY,
Chief Architectural Supervisor.

A THREE PLAN SERVICE

The San Francisco Insuring Office and the Sacramento and Fresno Service Offices of the Federal Housing Administration offer an improved service to architects, owners and builders by making corrections on drawings and in specifications instead of expressing requirements by conditions of commitments. THIS APPLIES TO NEW CONSTRUCTION ONLY.

To make this procedure practical, it will be necessary to deliver to them THREE copies of the drawings and specifications, in addition to any required by the mortgagee. The Architectural section will correct all three copies, retaining one and returning two. The owner then must keep his set on the job in accordance

with F. H. A. regulations. One set will be retained in the F. H. A. San Francisco office; therefore their inspectors will not have any to carry to the job.

Hereafter, whenever three sets of plans and specifications are sent to these F. H. A. offices they will assume that those interested wish to take advantage of this additional service and will proceed accordingly. In such cases Paragraph (c) on face of commitment, which refers to drawing and specifications, will be followed by the words "as corrected and approved." EXTRACTS FROM F. H. A. MINIMUM CONSTRUCTION REQUIREMENTS FOR NEW DWELLINGS LOCATED IN NORTHERN CALIFORNIA DISTRICT.

GENERAL

1. The requirements effective Jan. 15, 1938 provide for a Minimum Standard of Construction for properties offered as security for an insured mortgage and shall apply to all new construction on which the mortgage is insured by the Federal Housing Administration.

Note.—These requirements do not eliminate the necessity of providing complete specifications in connection with new construction.

2. Because of the wide variation in building code requirements covering materials and specific features in building construction, no attempt has been made to make the provisions contained herein comply with Building Code Regulations. The Federal Housing Administration has used the recommendations of the National Bureau of Standards, U. S. Department of Commerce; the Forest Products Laboratory, U. S. Department of Agriculture; and the Public Health Service, U. S. Treasury Department, as a basis for setting up these requirements. The requirements contained herein are considered necessary to produce a well-constructed dwelling which will serve as sound security for a long-term mortgage loan. However, strict compliance with the Uniform Building Code of the Pacific Coast Building Officials' Conference, the Local Building Code Requirements and Sanitary Regulations, together with the provisions contained in the specifications submitted, will be required in all cases where such requirements, regulations and provisions are of a higher standard than those contained herein.

3. The requirements set forth are purely MINIMUM. They are not to be built down to but form a basis to build up from, and this Administration will recognize and give credit to construction that exceeds these Minimum Construction Requirements.

4. The Minimum Construction Requirements shall be applied—

- (a) When the requirements contained in the specifications submitted are not definite or are lower than these Minimum Construction Requirements.
- (b) When the requirements of Local Building Codes and Regulations and the Uniform Building Code

of the Pacific Coast Building Officials' Conference are of a lower standard than those contained in these Minimum Construction Requirements.

(c) Where there are no existing Local Building Codes and Regulations.

5. The Federal Housing Administration is aware that there are numerous methods or ways of constructing a particular feature in a building, and these requirements, some of which are illustrated by details in the back of the booklet, do not indicate the only methods which will be acceptable, although they do indicate the methods of construction most generally practiced. Plans and specifications calling for methods of construction at variance with the Minimum Construction Requirements must be approved by the Chief Architectural Supervisor of the San Francisco Insuring Office, and it is preferred that they be prepared by a competent architect licensed to practice in the State of California.

6. The requirements apply only to conventional types of construction. Dwellings of special types, such as prefabricated, or seasonally occupied dwellings (summer homes) will be treated as special cases, and in order to qualify for an insured mortgage, each individual property will be considered on its own merits.

EXCAVATION

1. Excavation for all foundations shall extend to solid ground. If, upon excavation, other than solid ground is encountered, the footings shall be redesigned and details of same shall be submitted to the San Francisco Insuring Office of the Federal Housing Administration for approval.

2. Depth of excavation for foundations and piers shall be as provided by local building code regulations, and in the absence of a specific regulation, they shall be carried below natural grade, or finish grade if lower than natural grade, at least 8 inches for 1-story, 12 inches for 2-story, and 16 inches for 3-story structures.

3. All debris, such as stumps, roots, vegetation, and wood scraps, occurring within the building area shall be removed.

4. Finish grade shall slope to drain away from the building at least 5 feet except where there is provided adjoining the building, paving or protected areaway to divert surface water from the building.

5. Where the entire space under the structure is below finish grade, satisfactory provisions shall be made to keep the area dry.

FOUNDATIONS

Foundations shall not be less than the following:

Of good quality concrete for one story, top six (6) inches wide. Bottom, twelve (12) inches. For two stories, eight (8) inches thick at top, fourteen (14) inches thick at bottom of footing and fourteen (14) inches high with top not less than six (6) inches above adjacent finished and bottom eight (8) inches below

existing grade resting on firm soil. Top and bottom of footings to be level or stepped in gradual level steps to follow slope of site. Retaining walls and foundations acting as retaining walls shall be designed as such and shall be adequately reinforced. Nonbearing retaining walls not over 5 feet high and not exceeding 8 feet in length between lateral supports may be of plain concrete 6 inches thick on top, increasing 1 inch in thickness for each foot of height. All earth fill under floors or porches shall be retained by adequate concrete or Masonry walls. Piers for girder posts to be eight (8) inches square top, fourteen (14) inches square bottom and fourteen (14) inches high.

SUBFLOOR SPACES AND VENTILATION:

Whenever wood or metal floor systems are used, a clear space of 18 inches shall be provided under joists at all points with access doors two (2) feet by 18 inches to spaces not otherwise accessible for inspection, provided, however, that this clear space may be reduced to twelve (12) inches if all timber below flooring is grade-marked "foundation," "foundation grade redwood" or has been treated with approved wood preservative applied under pressure (three-quarters [$\frac{3}{4}$] inch minimum penetration). All such subfloor space shall be ventilated by means of screened vents with minimum open area of one hundred (100) square inches for each ten (10) lineal feet of exterior wall, so placed that there will be a vent within five (5) feet of each corner of the house, with good cross ventilating. Vents may be omitted on front elevation if adequate cross venting is provided. Vents may be larger and spaced less frequently provided area is adequate and that there is at least one vent within five (5) feet of each corner of house.

LUMBER

All framing lumber shall be grade marked.

All horizontal framing lumber such as floor and ceiling joists, girders, beams, rafters, purlins, etc., shall be No. 1 Common or better Douglas fir or the equivalent. All vertical framing lumber such as studs, columns, etc., shall be No. 2 Common or better. Subflooring, sheathing and roof boarding for one-story dwellings without basements shall be No. 3 Common and better boards, except that board lumber of the following species of wood may be No. 4 Common and better: Engelmann Spruce, Ponderosa Pine, Sugar Pine, Idaho White Pine. Studding and joists shall be spaced at sixteen (16) inch centers. All exterior stucco shall be placed over solid wood sheathing or equivalent, well nailed to studding.

FRAMING

Foundation sills two (2) inches by six (6) inches of grade—marked foundation grade redwood or of redwood coated all sides and ends with creosote or other approved wood preservative; (other wood may be used if treated with approved wood preservative applied under pressure). Sills to be bolted to foundations with

bolts one-half ($\frac{1}{2}$) inch in diameter, eight (8) inches long, spaced not over six (6) feet apart. The top of every exterior foundation shall be at the bottom of sill directly under floor joists, provided, however, that underpinning not less than fourteen (14) inches long will be permitted between sill and joist bearing plate under the following conditions:

Lower four (4) inches of underpinning to be dipped in creosote or other approved preservative. Underpinning to be not less in size or spaced less frequently than studs of story above and if underpinning exceeds four (4) feet in length it be not less in size than studding required for an additional story. Underpinning to have double top plate with corners lapped. Underpinning braced both ways at all corners with two (2) inch by full width "cut in" braces in the plane of wall setting one (1) inch by full width vertical thrust blocks snug to braces both sides of each stud. Corner braces shall be one stud removed from corner with wall spiked block on sill and plate in space between two adjoining studs at each end of brace. Adequate knee bracing shall be installed vertical to the plane of exterior wall. Such knee bracing to consist of two (2) one (1) inch by six (6) inch boards at forty-five (45) degrees securely nailed with at least two (2) feet clear inside of brace and not more than six (6) feet on centers. All underpinning shall have cross bracing in the plane of the wall at ten (10) foot centers.

Framing around masonry chimneys shall be built with header and trimmer joists and roof framing not nearer than two (2) inches from vertical shaft line of chimney.

CHIMNEYS, FLUES, GAS VENTS

1. Chimneys shall be lined throughout with fire-clay flue lining, except that in chimneys having solid brick walls 8 inches or more thick, the flue lining may be omitted. Minimum flue sizes for heating plants, $8\frac{1}{2}$ by $8\frac{1}{2}$ inches; fireplaces, $8\frac{1}{2}$ by 13 inches. Circular flues of equivalent effective area will be acceptable.

2. Flues for all gas-fired unit heaters shall be constructed of masonry or of not less than 20-gauge non-corrodible sheet metal with an area not less than 32 square inches, properly insulated with asbestos or other acceptable fireproofing material; or may be terra cotta "patent" flues or approved rigid asbestos-cement composition and shall extend through the roof. Vents for gas-burning hot water heaters shall not be connected to kitchen flues, but may be connected into a gas-fired furnace flue provided the connection is below the breeching of the house heating unit.

3. Chimneys for oil-burning installations shall be faced on the inside with fire brick from bottom of inlet to such heights as may be required by the Chief Architectural Supervisor. In no case will the required height be more than 8 feet.

4. In chimneys containing three or more flues, each group of two flues shall be separated from the other

single or groups of two flues by brick withes not less than $3\frac{3}{4}$ inches wide. Where two flues are grouped without withes, the joints in the respective flue linings shall be staggered.

5. Every masonry or concrete chimney and every fireplace shall be adequately reinforced and anchored to the structure. (See detail.)

6. In lieu of specific structural design, every chimney shall be reinforced vertically with at least 6 one-half inch round bars, placed before concrete is poured, hooked into foundations and extending unbroken the full height of the chimney and hooked into the concrete cap slab. When a chimney is reduced to 900 square inches in plan area, only 4 vertical bars are required to be extended above the smoke chamber. Horizontal ties of $\frac{1}{4}$ -inch round bars, carried continuously around the chimney, outside the vertical bars and 2 inches from the outside face, shall be spaced approximately 24 inches apart and imbedded in mortar joints.

7. Every chimney which is entirely or partly outside an exterior wall shall be anchored to the floor joists at every floor level and to the roof construction. Anchorage at each level shall be at least two $\frac{1}{2}$ -inch steel bars or straps, cast into a reinforced concrete slab covering the full cross-sectional area of the chimney and extending 3 feet into or over the floor or roof construction and bolted to or hooked over the joists or roof rafters. Concrete slabs at anchorage levels and chimney top shall be not less than 5 inches in thickness; shall extend beneath all hearths and cover the full cross-sectional area of the chimney, exclusive of flues, stucco, or outside 4 inches, if walls are 8 inches thick; and shall be reinforced with not less than $\frac{3}{8}$ -inch bars spaced 6 inches on centers both ways.

8. All fireplaces shall have hearths supported on fireproof construction. Hearths shall project at least 20 inches, measured from the chimney breast, and the width shall be not less than the width of the fireplace opening plus 20 inches.

9. Open fireplaces shall be constructed with smoke chambers and throats and shall be lined with fire brick or other materials approved by the Chief Architectural Supervisor. The depth of the fireplace shall be approximately one-half the width of the opening. The open area of the flue shall be not less than $1/10$ of the area of the fireplace opening. When an ash dump is provided, ashes shall empty into an enclosed chamber of fireproof material provided with a metal clean-out door.

10. Chimneys shall be properly flushed to make joints with walls and roofs weathertight.

CEMENT FLOORS, DRIVEWAYS, AND WALKS

1. Garage, terrace, and porch floors, walks, and driveways, if of concrete construction, shall have a minimum thickness of $3\frac{1}{2}$ inches and shall be properly surfaced and shall have a hard finish. Slabs shall be laid

on a bed (2 inch minimum thickness) of gravel, crushed rock, or other approved material. At least the bottom step of exterior wood stairs or basement stairs shall be of concrete or masonry on a concrete slab, with footings carried down to firm soil.

2. Terrace and porch floor slabs, when supported on trench walls or foundations, shall be adequately anchored to the main foundation wall.

3. Garage floors shall have an approved expansion joint between the driveway slab and the concrete apron at the garage door. Driveways over 30 feet in length shall have expansion joints not more than 30 feet o. c.

4. All outside brick steps shall be of hard-burned brick or approved paving brick. Common "salmon" or soft brick will not be accepted for treads, platforms, terraces, or for exterior use.

5. Exposed concrete and masonry floors and steps supported on wood construction shall rest on an adequate membrane flashed up on all intersecting walls so as to prevent moisture penetrating to woodwork or under the structure.

6. Basement or cellar floor slabs may be 3-inch concrete finished monolithic. Where floor drains occur, floor shall slope slightly to drain.

7. All openings in basement floors shall have covers which shall be flush with the finish floor.

8. When the heating plant is located above the basement, the floor area where the heating plant is located shall be finished with concrete 3 inches thick, or with other noncombustible material. Chamfer tops of floor joints when concrete is used on wood construction, or set floor joists down to allow for slab construction on top of the sub-floor.

9. Tile floors supported on wood construction shall have concrete underfloor not less than 2 inches thick. Slabs under shower baths shall be adequately waterproofed. When boarding supporting the underfloor is let down between the joists, chamfer tops of joists.

10. All downspouts or leaders emptying on grade shall have splash blocks constructed of concrete or other approved material so placed as to carry the rain water at least 3 feet from the building.

DAMP-PROOFING

1. Cellar, basement, and furnace pit shall be constructed to be dry, and when they occur in localities where dampness exists or water penetration impends, shall have walls and floors waterproofed.

2. In cases where subsurface water exists under pressure, walls below grade, and floors shall be adequately designed, reinforced, and constructed to be watertight.

3. Basement wood floors over concrete slabs shall be adequately protected against dampness and rot. The following or equivalent methods will be approved:

(a) Slabs shall be dampproofed by mopping with asphaltic compound or by other means approved by

the Chief Architectural Supervisor of the San Francisco Insuring Office. Preservative-treated wood sleepers, 1 $\frac{5}{8}$ inches square and 16 inches o. c. shall be anchored to the slab.

Note: Subfloor laid thereon shall be of treated lumber.

- (b) Finished flooring shall have edges oiled or otherwise satisfactorily primed and shall be laid directly on concrete slab in a full bed of hot asphaltic compound.

MASONRY WALLS

1. Masonry, concrete, and adobe structures shall be designed and constructed to provide adequate and effective resistance to lateral forces, in conformity with a structural design based on a sound engineering analysis.

2. Exterior masonry walls of other than solid reinforced concrete shall be not less than 8 inches thick in the upper story and not less than 12 inches thick in other stories. Walls shall be capped at top of each story with a continuous adequately reinforced concrete belt course into which joists shall be anchored. Wall plate for rafters shall be anchored by bolts spaced not more than 4 feet o. c.

3. If masonry walls are faced with brick or stone or other masonry materials, the total wall thickness shall be not less than 10 inches.

4. Where veneer is applied to masonry walls, bond shall be obtained by the use of headers or approved noncorrodible metal ties.

5. Proper provision shall be made for adequate bonding and anchoring together of all intersecting concrete and masonry walls.

6. At least 4 inches of solid masonry construction or other suitable material securely anchored to masonry walls shall be provided for beating under all floor joists framing into masonry walls.

7. Masonry veneer applied to wood frame walls shall have a nominal thickness of not less than 4 inches and a height not more than 35 feet, and veneer shall be anchored to the wood frame with approved noncorrodible metal ties spaced vertically 12 inches or less for brick and at each course for stone, and not more than 16 inches o. c. horizontally. Hot dipped galvanized 30-penny nails will be acceptable as anchors for brick. The use of veneer, other than 4 inches of brick, must be approved by the Chief Architectural Supervisor. In all cases, the wood construction shall be covered with waterproof building paper or asphalt saturated felt.

8. Joints between masonry units shall be not over $\frac{3}{4}$ -inch thick. All masonry joints in walls built of solid units shall be filled solid. All outside and exposed inside joints on the surface of the walls shall be flush, weathered, or tooled unless approved otherwise by the Chief Architectural Supervisor.

9. All parapet walls shall be capped with corrosion resisting sheet metal, concrete, terra cotta, tile, or stone coping.

10. Supporting lintels or properly designed masonry arches which will adequately support the loads will be required in the heads of all openings in masonry and masonry veneered walls.

11. In masonry buildings, all exterior walls above basement which are to be plastered on the inside, shall have a dampproof coating under the plaster, or shall be furred.

12. The Chief Architectural Supervisor may require the employment by owner or builder, of an experienced and licensed structural engineer, architect, or properly qualified inspector to check the installation of form work, reinforced steel or structural steel, and to give constant supervision to the installation of unit masonry or poured concrete construction, in connection with all work seriously affecting structural safety. Such structural engineer, architect, or inspector shall deliver to the San Francisco Insuring Office adequate reports and shall certify as to compliance with drawings and specifications, building code, and Federal Housing Administration requirements.

SHEET METAL:

Flashing of twenty-six (26) gauge galvanized iron; I.C. 40-pound tin or equivalent. Gutters twenty-six (26) minimum gauge galvanized iron or equivalent.

DOORS AND WINDOWS:

Doors to all rooms except closets and baths shall be not less than two (2) feet, eight (8) inches wide. (See State Housing Act for window sizes.) Required windows must not be less than ten (10) feet from the nearest building, nor less than five (5) feet from the lot line adjoining vacant property unless permanent provision for ten (10) feet clear open space between buildings is established, or unless special rulings of the Administration allow modification.

(Show detail section of sill and jamb of steel sash setting including mastic bedding, wood frame, bucks, etc., indicate vent area for all windows or drawings, also swing of doors and sash.)

LATHING AND PLASTERING:

Interior Plaster on wood lath applied full thickness of three-quarters ($\frac{3}{4}$) inch grounds, with six (6) inch expanded lath corner reinforcements at all corners. Exterior stucco shall be placed over sheathing, waterproof building paper and at least eighteen (18) gauge one (1) inch mesh galvanized after weaving furred by means of self furring fasteners.

HEATING:

In new dwellings, at least some method of heating must be provided, conforming to that which is typical of the community in which the property is located. All gas-fired heating appliances must be vented.

(Please turn to Page 52)

HOME BUILDING SIMPLIFIED BY CONSTRUCTION CONTROL

By W. H. Lowe

MODERNIZATION in home merchandising joins with improved building materials and architectural and construction methods and the new liberalized FHA to give home builders of today the advantages of easy acquisition at low cost of a home characterized by comfort and beauty. This development in encouraging home construction is the best news architects and engineers have received in a decade.

Although other firms are now adopting plans whereby the process of securing a home is simplified and reduced in cost through coordination of activities, Pabco pioneered in this field.

More than two years ago we realized what a long and circuitous process it was for the home builder to acquire a new home, and how little he was fitted to handle the many complicated steps.

In most instances the man building a home was technically absolutely unequipped by training and experience, and yet when he was ready to build he was faced with decisions in almost a dozen different specialized fields. He required the services of the architect, realtor, insurance agent, lender, title insurer, contractor, laborer, material manufacturer, and so on.

Pabco Plan Simplifies Problems

Building experts concluded one of the biggest retardants to home building was this great number of complex problems that had to be faced by the home buyer. Once home building could be simplified for the buyer it was felt a tremendous impetus to the building industry would result.

So, to give America, facing a serious housing shortage, more homes . . . to give employment in the stricken building industry . . . to stimulate business for the architect and other key professional men in home building, we developed the Pabco Construction Control Plan.

This "home building stimulator" is simplicity itself in that it operates a complete home build-

ing service from a single source—the building material dealer. The dealer is the contact man for all the other home building factors, with the architect functioning as his counselor and strategist.

We know that architects are particularly pleased with the plan, because, working with the dealers, it has developed new business for them. And with minimum effort, too.

Discoverer of the Pabco Plan is R. Hilliard, vice-president in charge of our sales, noted for his understanding of architects' problems.

There has been much talk recently of forms of housing other than those employing architects.

Mass Production has its Drawbacks

When present building methods are criticized, of course, there is presented the alternative of purchasing a "ready-made" home, but factory production of homes meets its Waterloo right off in individualism and personal preferences. Structural, design and climatic conditions offer additional obstacles, because no two home sites are the same.

Mass production of homes means standardization in design, which the majority of home owners do not want for the simple reason that homes must be lived in day in and day out. A home is one's most intimate possession and people like to express themselves in their homes. Look at the flowers in pots, pictures on the wall, color schemes, gardens.

Mass production may be satisfactory for factory areas where houses provide shelter for workers without regard for beauty or spiritual effects, but the great concourse of people still refuse to tolerate a housing condition wherein all homes are built alike, and the time is fast

WM. H. LOWE
President The Paraffine
Companies, Inc.



approaching when "look alike" will not even be satisfactory in factory areas.

There is also a need for fitting a home to its environment. It may be wanted for a hillside location having a south exposure and for a family of six. Can any standardized home meet all these requirements with perfect satisfaction? Will a home designed for one locality meet the architectural standards or preferences prevailing in another? These are natural problems that still need to be solved. What about the foundation? Can that be fabricated, too? Will building codes allow variation in the standards which they have established for given communities?

If the factory-built home is not satisfactory there was the old many-phase way of acquiring a home. And it was realized that all factors in building a home—architect, realtor, insurance agent, lender, labor, material manufacturer, surveyor, dealer, title insurer, builder, etc.—needed co-ordination. Here, in the West, out of all the nation, where frontier restlessness is still alive, industrial ingenuity has attacked the home building program and achieved noteworthy results.

Better Homes at Less Cost an Actuality

Enabling the prospective buyer to obtain every home building service from a single source, the Pabco Construction Control Plan operates through material dealers. Much time, money and effort is thus saved the builder. Getting-a-new-home stepped up along side getting-a-new automobile into the field of simplified purchase and reduced cost.

Improved merchandising and other factors have made themselves felt in lowered costs.

Sound building companies through wholesale-land buying, buying power, and in the West particularly, location close to material plants are developing well-designed, modest-priced homes in which the owners can take pride.

Manufacturers of building materials and architects have been preaching the doctrine of better homes at less cost for several years. They have made great progress in cutting costs while improving quality through technical advances. The building material factories in mak-

ing goods logically and properly, give mass production savings.

Comparative figures on cost of paint, roofing, floor covering, hardware and boilers for 1926 and 1937 show a decrease of from five to forty per cent. Other building material costs show a similar ratio.

Today the home-buyer has quality protection undreamed of even five years ago. Under the FHA, the operative builder, the man who specializes in building homes in quantity, aided by the architect, builds sturdy homes that have to be inspected and approved for financing and actual mortgage insurance.

The FHA has hastened a public consciousness of the value of "centralization" of building services, the building industry has responded to this.

Under the Pabco plan the financial arrangement cannot be completed until an architect has been employed and because of this we know the architects throughout the country will give their wholehearted co-operation to the Pabco housing plan.

Leadership by material dealers and architects, with their splendid advice, within the building industry, however, has simplified the home builder's problem. It has made it possible for him to secure architectural cooperation in the direction of modest, functional design. It has aided the contractor in using more efficient methods of construction. It has accomplished much by cutting costs on the basis of volume and turnover.

San Rafael Adopts "Coordinated" Plan

The coordinated plan, by making home building easier spurs construction, keeps architects busy and happy. It makes the material dealer a "home dealer." Public response can be appreciated in the case of J. B. Rice of San Rafael.

In 1937 Rice "coordinated" for the first time. One million three hundred thousand dollars in building in his territory resulted. His 1937 volume was one hundred per cent greater than his 1936 figures.

However, while home building costs have been cut twenty to twenty-six per cent, space for space, since 1926-1929, and twenty to

(Please turn to Page 44)

ARCHITECT HAS SOLUTION TO LABOR EMPLOYMENT

by Joseph L. Stewart

THE entire Nation has at last come to realize how very important the building industry is to the prosperity of the country and how any slump in this industry, even for a short period of time, can vitally affect all other lines of business. This is due to the fact that so many industries contribute directly or indirectly to the manufacture of building materials, such as, textiles, furniture, fixtures, etc.

President Roosevelt realizes the importance of reviving the building industry and has suggested the immediate launching of a home-building campaign on a large scale. While such a program would of course stimulate this industry for a period of time, and is therefore a highly commendable procedure on this account, it nevertheless does not solve the most important problem of all—assurance of a steady job for mechanics and other labor.

As a practising architect for 26 years I have had ample opportunity to familiarize myself with the problems confronting labor, and I believe I have a solution. At least my assumed remedy should be worthy of serious consideration because I have discussed it with building mechanics, large and small property owners, as well as mortgage lenders, and have yet to find any adverse criticism. My plan is as follows:

Empower some agency of the Government to refinance existing mortgages on real estate or make loans on new construction subject to the following conditions: Rate of interest to be paid the Government $3\frac{1}{2}\%$ per annum, plus an additional $1\frac{1}{2}\%$ which is guaranteed to be spent by the property owner each year for the upkeep of his property. The usual amortizing payments on principal to be paid monthly in addition to the interest and upkeep charges. It

might be stipulated that the $1\frac{1}{2}\%$ upkeep charge shall be applicable only to labor and is not to be used for the purchase of furnishings, and alterations to the structure itself, such as modernizing the mill-work, plastering, plumbing, painting. The owner shall render a notarized statement each year accompanied by receipted bills to the amount of expenditure he is required to make in order to comply with the conditions of his loan.

In order to clarify the situation and reduce it to cold facts and figures, suppose we start with a fund of \$5,000,000,000. This sum, when finally loaned by the Government, would require an annual expenditure of \$75,000,000 by the property owners, netting Uncle Sam a clear profit of \$50,000,000 per year after charging off mortgage losses and overhead expenses.

Now, let's review the situation and see who has been penalized by the institution of this novel idea. Certainly not the property owner, because he has been allowed the benefit from the spending of \$75,000,000 on his own property. His rate of interest, if loaned by a mortgage company, would surely average him 5% per annum, therefore, he has received this benefit without greater financial cost to himself. His property is kept in a better state of repair than would normally be expected because of the "forced spending" of $1\frac{1}{2}\%$ annually, and which, indirectly, is not taken out of his pocket. Wouldn't you like to trade with a banker who would give you back each year some of the interest you had paid in order that you might improve the appearance of your property and incidently his own security?

Certainly the Government has not been penalized, because of the \$50,000,000 clear profit

per year. I have no figures available on the probable loss ratio to be expected on such a large scale lending program, but the Government has had a wonderful opportunity to compute such a program based on experience with FHA. And remember too, that the loans refinanced would be and could be on a more conservative basis than an 80% loan. The figures I have used are merely for illustrative purposes and naturally aren't to be construed as accurate calculations. When such calculations have been finally made, the profit to be anticipated by the Government may be considerably reduced. The details for working out such a suggestion are, after all quite simple, when the facts attendant in connection therewith have been ascertained.

Now, let's see what all of this has done for labor. In the first place, we guarantee to spend on labor alone \$75,000,000 per year. Not, for three months (average time for building a small home) but for the next TWENTY YEARS, the life of the loan. Imagine GUARANTEEING SEVENTY FIVE MILLION DOLLARS WORTH OF JOBS FOR THE NEXT TWENTY YEARS. But isn't this the goal we are striving to reach? The cure we are seeking for those who want to work? The matter of wages or cost of materials, whether too high or too low, does not enter into this situation at this time. What every man wants is some assurance that he is going to have steady employment.

Obviously then, the only one who could object to such a program would be the lender of money, as a number of good mortgages now existing on income property especially would be refinanced and the mortgagor would be forced to seek another investment. However, due to that very fact—that \$5,000,000,000 would have to seek new channels, would stimulate the launching of new enterprises. People with ideas would have more opportunity of exercising them. Capital would be seeking instead of being sought and the future would be brighter for labor and, incidently, for the architect.

HOUSING SHORTAGE

(Concluded from Page 27)

In view of all the foregoing it is safe to say that we have a shortage of at least 25 thousand modern dwellings within a 10 mile radius of Oakland, a like shortage for San Francisco and a greater shortage in the Los Angeles area. Inasmuch as replacement is not keeping up with obsolescence, fire destruction, increase in population and marriages, it stands to reason that living conditions are getting worse instead of better. A vast market exists for the great American Housing Enterprise, for surely, 70 per cent of our people are not complacent humans, unconcerned as to their living conditions. After all, people want something more than a roof over their heads. Clearly the housing market exists and certainly is not being oversupplied by overproduction.

Here, then, is a direct challenge to the architectural profession.

CONSTRUCTION CONTROL PLAN

(Concluded from Page 42)

forty-five per cent greater quality is given for the dollar, primarily because of the slash in material, lot, financing, selling costs and profits, there is still room for considerable improvement.

The building industry needs to exert every effort to make comfortable and attractive homes available to the American masses at prices which they can afford to pay. But that effort need not necessarily be directed solely to securing mass production of the complete housing unit. Every day, research brings advances. And with advances already brought, huge strides have been made under our existing system, and the home builder can take advantage of the opportunities offered with absolute confidence that his interests will be fully protected and he is getting much more for his building dollar.

The building industry has gone a long way in the last few years from "jerry built" homes to the beautiful modern structures architects are building now, the industry knows it has a long way further to go and will make the grade.

DESIGN AND CONSTRUCTION OF THE SAN FRANCISCO WORLD'S FAIR

By John J. Gould, Chief Structural Engineer

IT IS my privilege to speak to you of construction features of the Golden Gate International Exposition.

The Department of Works is responsible for the physical creation of the Fair, both design and construction, for transportation, for police, fire and health protection, and for maintenance. At the head of this department is a member of your section, Mr. W. P. Day, Director of Works and Vice President of the Exposition Company.

The Department of Works has a budget allowance of more than 19 millions of dollars. Of this amount ten millions of dollars in works contracts have been let and completed. Another five and one-half millions in works contracts have been let and are being rapidly completed. For the remaining portions of the work contract documents are being prepared.

The reclamation of the 400 acre shoals and the construction of the sea wall was completed in the fall of 1937. This work together with a three million gallon reservoir and two thousand feet of roads and bridges on Yerba Buena Island, was built or contracted for by the U. S. Army Engineers. Bridge and trestle work, nine hundred feet long, connecting with the westerly portion of the Bay Bridge has been let in a similar manner and soon will be under construction. On the south side of the island a road structure 1,800 feet long is being built by the Exposition Company. The entire road system will be completed by the end of July 1938, and will have a traffic capacity of 3,000 automobiles per hour in one direction. Already completed and available for use are the Ferry Slips on the shoals. These can accommodate 50,000 passengers per hour in one direction.



LOOKING UPWARD, INTERIOR OF CENTRAL THEME TOWER
G. G. INTERNATIONAL EXPOSITION

With reference to the building program—About 1,000,000 square feet of permanent and temporary structures are now sufficiently complete to receive exhibits.

Structural work for ornamental towers, main courts, and other architectural features is sufficiently advanced so that many plaster contracts have been let and bids are being taken for additional ones.

Some of the methods developed by the contractors in construction of the temporary exhibit palaces may be of interest. The exterior walls of these buildings are of studs covered with Byrkit Sheathing. These were fabricated on the ground in panels and were lifted into place.

Editor's Note—A talk before San Francisco Section of Civil Engineers February 15, 1938.



STRUCTURAL STEEL FRAMING OF CENTRAL THEME TOWER, GOLDEN GATE INTERNATIONAL EXPOSITION, TREASURE ISLAND

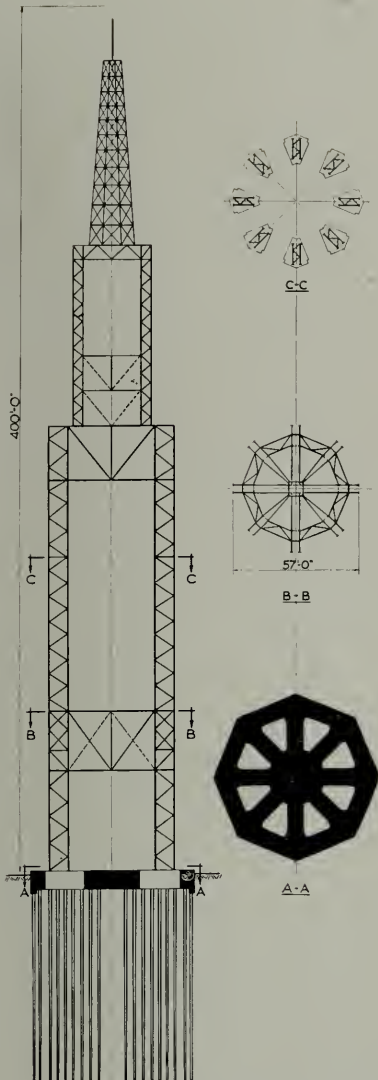

DIAGRAMATIC SECTION,
CENTRAL THEME TOWER

At first the wall panel unit was 38' high and 132' long and required two derricks to lift it into position. But this was found to be cumbersome to handle and slow to erect and was replaced with a smaller panel 22' x 40' requiring only one derrick. Similar methods were employed for placing roof rafters and other structural elements.

As a further example: A 200' span timber arch prefabricated on the ground was raised from a horizontal into its final position, the entire setting operation consuming about 30 minutes.

These prefabrication and erection schemes had a very decided influence upon the reduction of accidents in addition to saving time and money. Those of you who are interested may find further details in current technical magazines.

The construction of many of the buildings was financed with P. W. A. and Exposition funds, and the detailed supervision of construction is being done by engineers of the Public Utilities Commission.

About a year ago I had the opportunity to discuss before your section some of the structural features employed in the design of buildings. Considering the nature of the foundation problem it was our aim to make all structures wherever possible of a flexible and statically determinate type. Because of certain architectural requirements some of these principles could not be used in the design of the 400' high Central Tower, which is now under construction.

Architecturally, this tower requires that daylight may be seen through a number of openings. The plan is octagonal and for a distance of 100 feet, in the middle tier, eight individual piers supply the principal architectural motif.

The diameter of the architectural tower base is 59 feet, and that of the steel frame 57 feet.

In order to provide for stability against overturning due to wind, each steel column is anchored to the concrete foundation by means of ten bolts $2\frac{3}{4}$ " in diameter. The total vertical load at the top of the base being 3,000,000 pounds and the overturning moment 50,000,000 foot pounds.

The calculated horizontal wind load of 300,000 pounds is transferred to the ground through the piles of which there are 212.

In the majority of structures on the shoals the piles were designed for a maximum downward vertical load of twenty to thirty tons, or a

maximum uplift of seven and a half tons. For resistance to horizontal forces $2\frac{1}{2}$ tons were allowed on the piles. In the case of the Central Tower these loads were held to more conservative limits. The horizontal shear amounts to only 1,400 pounds per pile and no tension or uplift was allowed in the piles for a wind of 20 pounds per square foot acting on the tower.

The footing was built in the shape of an 8-spoked wheel 65' in diameter and 7' deep—this arrangement being chosen to avoid the crowding together of piles. In the rim as well as the spokes only two rows of piles were used. The idea is to increase the skin friction resistance of the entire pile group and also to utilize a large sub-surface area at the tips of piles where the loads must be transferred to the existing soil.

The small diameter of the tower, its octagonal shape together with certain architectural requirements presented some complex problems of design and detail of the superstructure.

Because of the 100' long unsupported columns in the 2nd Tier the principal wind forces had to be resisted by a series of rigid frame bents. These bents occur on a radii corresponding to the spokes. In order to provide torsional resistance in the tower, a circumferential bracing system was built, strong enough to resist a five pound per square foot unbalanced wind load. The main columns, just mentioned as having 100 feet unsupported length, are 4' x 9' in plan and consist of 4 legs of 2 heavy angles.

The deflection of the tower was computed to be 20" at the top when subjected to a wind load of 20 pounds per square foot. Of the total deflection, 7" may be roughly assigned to lengthening and shortening of the columns, $11\frac{1}{2}$ " to bending deformations, and $1\frac{1}{2}$ " to shear deformations in the main column webs.

Of the total maximum stresses occurring in the main columns about 80 feet above the ground 15% are caused by D.L., 10% by deflections of the structure, and 75% by wind loads.

I feel that the last item is of importance when analyzing the requirements of the Field and

Riley Bills for wind load resistance. These, I feel, should be enforced in a liberal manner considering the short period of a heavy wind storm. This opinion is reinforced by recent observations on the Shoals where we found that the structures are in excellent condition.

Another phase of activity of the Department of Works is the distribution of electric power. The 1915 Panama Pacific Exposition pioneered the development of modern illumination, using flood and indirect lighting effects. For the coming Exposition full use of more recent improvements are planned, as you may judge from the fact that electrical energy equal to 16,000 kilowatts will be available on this 400 acre site. This is enough to supply the present needs of cities like San Jose or Sacramento.

Other utilities, such as sewage disposal, water supply, and the high pressure distribution system are about 75% complete. This work entails a total expenditure of $\frac{3}{4}$ of a million dollars. Among its many problems is the matter of leaching out salt from the existing ground prior to the landscaping. The general elevation of the reclaimed area is 13'-0" above mean lower low tide. Because of the method of pumping used to transfer dredger fill from borrow pits to the shoal site, the fill is now impregnated with salt, the salt water table being at about elevation +12'-0" at the center of the Island. The lowering of this salt water to about +6'-0" is now under way. It is accomplished by sinking well points $1\frac{1}{4}$ " in diameter to a depth 25' below the surface and removing salt water by pumping. The well point is provided with a 10" diameter envelope of coarse sand and the wells are spaced about 60' apart. At the present time 20 units each consisting of 12 well points are being operated and in general the results are most encouraging. It is estimated that this process will reduce the salt content of the upper 5' of the existing ground by 80%. The remaining 20%, it is hoped, will be eliminated by rainfall, and where this is not the case, artificial leaching will be resorted to.

As previously pointed out, this is in preparation for the receiving and planting of trees,

shrubs and flowers. The Horticulture Division is another unit of the Works Department, and preparations have been made to shortly start shipping operations.

There are to be moved and planted 4,000 trees, 40,000 shrubs, 80,000 tons of loam, and millions of flowers. Of the trees there are about 1,000, varying in height from 25' to 75' and weighing from 5 to 35 tons.

This project involves the expenditure of almost 2 millions of dollars and is being financed jointly by the Federal Government, through the W. P. A., and the Exposition Company.

To realize the extent and beauty of this project I urge you to visit the 14 acre nursery at Balboa Park, which is the principal storage and distributing unit of the several horticultural projects located within the Bay Region.

The color schemes for the horticulture are being developed by the Division of Architecture and the Director of Color, both of the Department of Works.

The Division of Architecture has had an important job of planning the buildings for their beauty and utility. The designs have been created by the individual members of the Architectural Commission and the working drawings have been prepared by the Department of Works.

The question has been raised, and I presume it applies to all expositions of all ages, whether or not this show will open on time. In my discussion I have endeavored to demonstrate that the job assigned to the Department of Works will be finished on schedule.

ENGINEERS INSPECT EXPOSITION BUILDINGS

The towers and exhibit palaces of the Golden Gate International Exposition received a thor-

ough inspection Saturday, March 26, when 100 members and guests of the Structural Engineers Association of Northern California, H. B. Hammill, President, visited Treasure Island. J. J. Gould, Chief Structural Engineer for the Exposition, whose article precedes this report, and members of the Division of Structural Engineering, explained to the visitors the various engineering phases involved in the design and construction of the huge Exposition buildings and towers. As the plastering was recently begun on the various units, an excellent view was obtained of the main structural elements of the buildings. The chief interest of the engineers centered on the structural frame of the 400-foot high Tower of the Sun, the steel work of which is now complete. The permanent buildings, the two hangars and air terminal building, of reinforced concrete and steel, received considerable attention because of the economical methods employed in the design for obtaining resistance to vertical and lateral forces.

As the major part of the construction is of wood, the methods employed in the design and construction of the various timber units were critically examined. Different types of construction were used. In the main exhibit palaces three-hinged arches were used, the most notable feature of some of these buildings being their size, 200 feet clear span and 887 feet long, covering 4 acres of exhibit space under one roof.

The structural and architectural features of the various courts, towers, elephant towers and triumphal arch, where use was made of the most modern timber engineering designs, was given much attention by the engineers.

This was their first excursion this year to a major engineering project. All of the arrangements were planned by the Vice-Chairman of the Program Committee, Hyman Rosenthal.

ADOBE HOUSES IN FRESNO COUNTY, CALIFORNIA, DEMOLISHED
BY RECENT FLOODS





THE heavy rains in California in February and March caused rivers and creeks to overflow their banks, flooding lowlands and menacing homes and live stock. In Fresno County the flood waters were especially destructive, sweeping away parts of adobe houses occupying flat ground, doing immeasurable damage to outbuildings and highways. The accompanying photographs tell graphically the extent of the flood's ravages; mute testimony of the failure of adobe walls to stand up under abnormal conditions. Fresno's experience would seem to warn against building adobe structures on low ground. Old timers, we are informed, invariably selected elevated spots for their adobe homes.

F. H. A. REGULATIONS

(Concluded from Page 40)

PLUMBING:

Stall showers with cement or tile floors to have double drain shower drain fittings with adequate water-tight pan turned up eight (8) inches on sides and draining into lower drain.

Note:—Requirements for adobe construction will be published in *The Architect and Engineer* for May.

MISCELLANEOUS

Applications, Drawings and Specifications:

Applications for loans are made through approved lending institutions. Applications covering new construction must be accompanied by complete drawings and specifications. (See F. H. A. No. California Property Standards—Circular No. 2—Part IV.)

Inspections:

Three inspections are made on new construction and the F. H. A. Office must be notified as outlined in the commitment document.

Changes:

The F. H. A. Office must be fully informed of any proposed changes in plans and specifications after commitment has been made.

Cost of New Construction:

The following items are not included in estimating cost:

1. Grading of grounds, retaining walls, lawns, shrubs, and trees, wire or wooden fences, temporary buildings, such as wooden sheds, playhouses, etc.

2. Refrigerators, stoves, lighting fixtures, except to 1% of total value of house, shades (roller or Venetian), draperies and furniture, screens.

3. Over elaboration or expensive features of no particular value either in use or appearance, chattels or accessories.

Notes: Use of pressure treated lumber for mudsills, two (2) lowest sheathing bear support of cement steps and decks is recommended as minimum termite deterrent and will secure higher durability rating.

F. H. A. General Property Standards, Northern California Property Standards and Northern California Minimum Construction Requirements may be obtained on application at the San Francisco Insuring Office, 433 California Street, S. F., or at the Sacramento or Fresno Service Offices of the F. H. A.

MARK DANIELS GIVES TALK

Mark Daniels discussed "Architecture and Landscaping and Their Relationship" at the last meeting of the San Francisco Architectural Club.

Members meet at the club after office hours on meeting nights to dine together. Meetings ordinarily are closed to all but club members, but owing to wide interest in Mr. Daniels' subject, the meeting was thrown open to architects, engineers and landscape architects.

Officials of the club are Leland Hyde, president;

Frank Trabucco, vice-president; Leo Daly, Secretary, and Frederick E. Rugen, Jr., Treasurer.

ARCHITECTS DISPLAY WORK

Berkeley's 10th annual "open house" was held March 31 with an estimated attendance of 12,000. These reviews are sponsored jointly each year by the Berkeley League of Women Voters and the Junior Chamber of Commerce.

Several displays were of especial interest to architects, builders and home owners and these exhibits were arranged jointly by the City Planning Commission and the Bureau of Buildings and Inspections.

Of major interest, naturally, were the many scale models and accompanying plans and photographs generously offered to the city by San Francisco Bay area architects.

Acknowledgement of these favors is made to John B. Anthony, Gardner A. Dailey, Vernon De Mars, Michael Goodman, B. Reede Hardman, Richard J. Neutra, Henry T. Howard and Winfield Scott Wellington.

The U. S. Farm Security Administration, through the courtesy of Jonathan Garst, regional director; Burton D. Cairns, regional chief; Corwin R. Mocine, landscape architect; and Vernon De Mars, regional architect, furnished models of low-cost housing developments, together with colored movies of various re-settlement projects.

A. C. Horner, structural engineer, sent a valuable exhibit of timber connectors, which was displayed in two panels. This will be left on permanent display in the City Hall.

WILL MAKE DALMO PRODUCTS

Due to the expansive Federal school building program and also due to the many diversified lines of the Dalmo Manufacturing Company, the MacDonald Hardware Manufacturing Company has been organized to manufacture and market building hardware specialties formerly made by Dalmo.

Asserting its confidence in the business outlook, the MacDonald Hardware Manufacturing Co. has completed extensive alterations to the building at 963 Harrison street, San Francisco, where the company will manufacture Dalmo Simplex window products, Kramer flush valves, Hauser casement and awning type fixtures and other building hardware products.

Now the largest manufacturer of specialties of this type in the United States, the company is expected to become a leading factor in the national field with the perfection of present plans to increase its operating force and to promote an aggressive nation-wide merchandising campaign.

The officials are T. I. Mosely, Edmund B. MacDonald, and Alvin M. Karstensen, the latter general sales manager. Sales experts in the company are William J. Driscoll, formerly of the Sloan Valve Company, Jack Reid in the valve department, and Carl Hauser in the window department.

Selling will continue through regular trade channels.

With the Architects

WILLIAM C. KNIGHTON

William C. Knighton, 73, associated with the firm of Knighton and Howell, 404 U. S. National Bank Bldg., Portland, died suddenly March 14 at his home in Portland, of heart trouble.

Mr. Knighton was born in Indianapolis, Ind. He was a past member of the Oregon State Board of Architectural Examiners and past president of the Oregon Chapter, American Institute of Architects. He had been associated with Leslie D. Howell 16 years.

Among outstanding buildings designed by the firm are the Eastern Oregon State Hospital, Oregon Supreme Court and Library Building, the University of Oregon administration building, Forest Grove Masonic Home, Grant high school in Portland, Pythian home, Vancouver, Wash., Salem high school and State office building, Salem, and the boys' training school at Woodburn.

CARL SIEBRAND

Carl Siebrand, architect of Seattle, died February 15. Born seventy years ago in Germany, where he was educated at the Technical College of Buxtehude and the Institute of Technology at Stuttgart, he came to America at the age of nineteen years and was associated with two architectural firms in Boston, Snell-Gregerson and Peabody-Sterns, in the 1880's. Shortly after the fire in 1890, he came to Seattle and was naturalized as an American citizen. In the same year he helped found the Washington State Chapter, A.I.A.

Mr. Siebrand's architectural achievements in Seattle and vicinity include the Broadway High and T. T. Minor schools, the old Northern Life Building, the O. B. Williams Building, the H. C. Henry private art galleries, the Acacia Mausoleum, the Kitsap Brewery at Port Orchard and the Northwest Distillery.

BRANCH Y.M.C.A. BUILDING

W. H. Ratcliff of Berkeley is preparing working drawings for a two story frame branch Y.M.C.A. building to be built on Tenth Street, near University Avenue, Berkeley, at an estimated cost of \$25,000.

Mr. Ratcliff has also prepared plans for a \$20,000 house in Walnut Creek, Contra Costa County. W. Sorrensen is the contractor.

UNIVERSITY DORMITORY

Work will soon start on a new dormitory for women students at the University of California. The site is north of Memorial stadium. The plans will be drawn by H. C. Corbett of New York and William W. Wurster of San Francisco.

PERSONAL

George M. Lindsey, architect, announces the organization of the Lindsey Company to design and construct all types of buildings under one complete building service. The company's office is at 6305 Yucca Street, Los Angeles.

Everett E. Parks, architect of Santa Ana, is now associated with the office of J. Robert Harris, A. I. A., Hollywood. Their address will be J. Robert Harris, A. I. A. and Everett E. Parks, architects, 6715 Hollywood Boulevard, Hollywood.

Otto G. Hintermann, architect, announces the opening of a new studio at 2847 Golden Gate Avenue, San Francisco. Mr. Hintermann was formerly located in the Call Building on New Montgomery Street.

George Gove, member of Heath, Gove and Bell, architects, Puget Sound Bank Bldg., Tacoma, talked on residence construction at the March 25 meeting of the Women's University Club, Sixth Avenue and Seneca Street, Seattle.

Edward M. Hicks, 3905 E. Burnside Street, Portland, has been announced as 1938 winner of the Ion Lewis traveling scholarship in architecture.

Alvin S. Erickson, practicing architect in Everett, is now occupying new offices in Rooms 316-17 Central Building, Everett, Wash. He formerly maintained an office in Wenatchee, Wash.

WAREHOUSE ADDITION

From plans by Will G. Corlett the Geo. R. Borrmann Steel Company will build a steel frame and corrugated iron addition to its Eighth Street warehouse in Oakland. The building will be one story, 70 by 196 feet.

BERKELEY ARCHITECT BUSY

New work in the office of Edwin Lewis Snyder of Berkeley includes a \$12,000 residence for Alfred C. Aitken of 53 Domingo Road, Berkeley; house on Shasta Road, Berkeley, for Chas. W. Bowman and residence in Clayton, Contra Costa County, for W. M. Casy.

WAREHOUSE BUILDING

Matson Navigation Company has started construction of a one story steel frame warehouse at Beale and Bryant Streets, San Francisco, from drawings by Kaj Theill, structural engineer, 215 Market Street, San Francisco.

TWO SACRAMENTO DWELLINGS

Architect Herbert Goodpastor, Mitau Building, Sacramento, has designed a \$9,000 house for L. Heringer and a \$6500 house for J. L. Emigh, both dwellings to be wood frame with stucco exterior and cedar shingle roofs.

LANDSCAPE ARCHITECTS

San Francisco Chapter, A. S. L. A.

President
L. Glenn Hall, San Francisco

Vice President
Helen Van Pelt, San Anselmo

Secretary-Treasurer
Geraldine Knight, San Anselmo

Oregon Landscape Architects Here

During the week of March 14-19, Professors Frederick A. Cuthbert and W. Dorr Legg, Department of Landscape Architecture, University of Oregon, members of the A.S.L.A., directed thirty-two of their major students on a tour of private estates, parks, civic planning projects, etc., in the San Francisco Bay area. Members of the San Francisco Chapter assisted in making up an interesting and instructive itinerary.

A reception was given in their honor by the Landscape Design Club, University of California, at their headquarters on the Berkeley campus. Professor Cuthbert stated it is their aim to have such a tour each spring, alternating with trips to Washington, British Columbia and San Francisco. The students were particularly interested in the smaller public projects which were designed by Chapter members and constructed under W.P.A.

Chateau Gardens of Sweden

On April 12 Thomas D. Church, Landscape Architect of San Francisco and member of the Chapter, gave an illustrated talk on "Chateau Gardens of Sweden" on the Berkeley campus under the auspices of the Landscape Design Club. The slides were made from pictures taken while Mr. and Mrs. Church were on a study tour of the Scandinavian countries last summer. Those seeing these excellent illustrations all expressed surprise at the fine composition of these little publicized and little known gardens of Sweden. All members of the Chapter were invited, together with graduates and active major students in Landscape Design, University of California, Berkeley, and their friends.

Educational Interest

In order to maintain constructive interest in the educational phase of Landscape Architecture, the San Francisco Chapter has arranged to be the guests of the Landscape Design Club, University of California, at one annual meeting a year. It is the desire of the Chapter to develop mutual understanding between those practicing in the profession and students now majoring in this field.

Landscape Work Under Construction

John Wm. Gregg, Landscape Architect, Member A.S.L.A., Berkeley, California, reports the following work under development:

Outdoor Theater, University of California at Los

Angeles; Administration Building, University of California at Los Angeles; Allison & Allison, Supervising Architects, and Ralph D. Cornell, Assistant Landscape Architect.

W. W. Gilmore, Owner; J. W. Plachek, Architect; Development of Garden, Berkeley, California.

Dr. Grover C. Johnson, Owner; Additional Garden Development, Berkeley.

E. Leslie Kiler, Landscape Architect, Member A.S.L.A., Palo Alto, California, reports the following:

Outdoor Theater, Stanford University, Palo Alto, California, has been completed under W.P.A.

This project has received the plaudits of many visitors who visualize the ultimate effect and use.

CALIFORNIA STATE BUILDINGS

The State of California has inaugurated a \$23,000,000 building program scheduled for completion by the end of July, 1939, and designed to relieve over-crowded conditions in State buildings and provide employment.

Allocation of the money, approved by the 1937 Legislature, includes the following projects:

Office building in Sacramento, \$1,800,000; \$3,500,000 for a "first offender" prison in Southern California as soon as a site is selected; \$1,185,000 for new wards, new laundry and other structures at Napa State Hospital; \$1,350,000 for new buildings at the State Fair Grounds.

At Agnew State Hospital, a new ward and other buildings, \$725,000; barracks and other structures at the Yountville Veterans' Home, \$950,000; detention cottages, nursery building and other additions at Pacific Colony Home for feeble-minded, \$1,500,000.

Office and storage building for the State printing plant and State purchasing department, Sacramento, \$200,000; buildings and additions at the Sonoma State Home for the feeble-minded, \$1,500,000; bakery, ward building and laundry at Stockton State Hospital, \$400,000; construction at Camarillo State Hospital, \$2,767,000.

California Polytechnic School at San Luis Obispo, \$110,000; State buildings at 1939 Fair, \$1,500,000; Industrial Home for Adult Blind at Oakland, \$200,000; office building, State Treasury Department, Sacramento, remodeling, \$150,000; additions to Los Angeles State Building, \$50,000.

Pacific Coast Architects' Chapters

SOUTHERN CALIFORNIA CHAPTER

The compilation of a true regional plan and a mass of statistical data were described by Bryant Hall, housing and research engineer for the Los Angeles Regional Planning Commission, at the March meeting of Southern California Chapter.

Referring to the project as a superficial study of what land in the county is used for, Mr. Hall gave a comprehensive account of how the field work was done, the manner in which the data were made into 475 separate small maps and the final step of assembling these maps and transposing them into one large 8x12-foot map.

When completed, he said, the maps will have a great deal of historical interest and will be invaluable for planning purposes and statistical studies of comparative use of lands. The maps are accompanied by 33,000 cards on which statistics are listed.

Charles H. Cheney spoke on regional planning. He said that one-third of the metropolitan district of Los Angeles was ineligible for F.H.A. mortgage insurance. This condition he attributed to improper zoning and other causes beyond the control of the F.H.A. or lending institutions.

A report on a recent meeting dealing with possible methods of changing state legislation, in order to permit the employment of private architects on public works, was made by Earl T. Heitschmidt. The meeting, held in San Francisco, was jointly attended by members of the various architectural organizations in California.

A. C. Zimmerman called attention to the American Society of Testing Materials standard specifications, copies of which are now on file in the Chapter office in Los Angeles.

A. E. Barnes, a member of Gladding, McBean & Company and treasurer of the Producers' Council Club of Southern California, stated that the club had arranged several informational meetings for this spring and early summer.

WASHINGTON CHAPTER

The regular monthly meeting of Washington State Chapter, A.I.A., was held Thursday, March 3, with vice-president Ernest T. Mock, of Tacoma, directing the proceedings. Business problems included union organizations of architects' offices, the six-hour day in the building trades, and increase of Chapter representation in the Washington Construction League. The lighter side of the meeting began with a buffet supper at 6:15.

Announcement of an architectural competition for the design of a Washington State exhibit building at the coming New York World Fair was made by J. Lister Holmes.

Preparations for submitting designs at the national exhibit of the New York Architectural League to be held this spring were reported by John T. Jacobsen. The Chapter is sponsoring Mr. Jacobsen's application for the Langley Scholarship.

OREGON CHAPTER, A. I. A.

(Minutes of all future meetings will be published regularly in these columns.)

Regular monthly meeting of Oregon Chapter, Tuesday, February 15, at Hilaires Restaurant, Portland.

Present: Howell, Jones, Crowell, Knighton, Parker, Brookman, Baer, Schneider, Turner, I. Smith, Wardner, Wick, Stanton, Dity, Herzog, Fritsch, Morin, Morden (guest).

After dinner President Howell opened the meeting. Minutes of the annual meeting read and approved with corrections by Stanton re: all traveling sketches by Hal Onstad.

Regional Director Crowell addressed the group on the situation in the Washington State Chapter relative to unionization of draftsmen in Seattle. Matter still in an unsettled and troublous state as one large project (the Seattle Ball Park) has been held up because the architect's drawings failed to bear the union stamp. Reports of similar developments in Chicago and New York, with picketing of buildings under construction.

President Howell read a letter from Walter Church relative to the 52nd Annual Exhibition of the New York Architectural League whose show this year is to be made nationwide in scope. Mr. Church has been appointed general chairman for the Oregon district, the other members being, Gabriel Lavarre (sculpture), Abbott Lawrence (painting), and Fred Cuthbert, University of Oregon (landscape architecture).

President Howell read a letter written by the executive committee to the First Church of Christ Scientist at Eugene relative to solicitation of sketches.

President Howell read another letter from Institute Committee Chairman McCormick on Housing.

Secretary Morin read letters from the Kansas City Chapter and the Pittsburgh Chapter to which he was instructed to write courteous replies.

H. Doty called attention to the broadcast from the Oregon Building Congress on their annual meeting at the Imperial Hotel.

Secretary Morin read letters from the Connecticut and New York Chapters relative to competitions for the buildings involving the expenditure of public funds. Motion by Parker, seconded by Herzog and carried, that Institute Competitions Committee (Howell, Crow-

ell and Holford) be instructed to report to the Chapter on these resolutions.

Regional Director Crowell spoke extensively on the Tax and Refund system to equalize the expenses of delegates to Institute conventions. Motion by Doty, and seconded, to compliment Mr. Crowell on his exhaustive work in this direction. President Howell appointed special committee, Herzog, Doty and Stanton, to draft resolution anent this matter to be circularized to all Western Chapters.

ROI L. MORIN, Secretary.

Annual Meeting

A record attendance marked the 26th annual meeting of the Oregon Chapter in January. Those present were:

Members and Associates (39)—Messrs. Howell, Herzog, Foulkes, Dukehart, Barnes, Heims, DeYoung, Jacobberger, Belluschi, Tucker, Johnson, Parker, Morin, Wallwork, Holford, Brookman, Stanton, Dougan, Logan, Forrest, Wick, Baer, Angell, Aandahl, Doty, Crowell, Wardner, Turner, A. Lawrence, Church, Johnston, Hayslip, Sundeleaf, Fritsch, Jones, Marsh, Hilgers, Schneider.

Chapter Guests (6)—Messrs. Gwyne Hoss, O. R. Wayman, Ormond Bean, Ben Hazen, Henry Tymer, C. C. Weideman.

Individual Guests (39)—Manson Bennett, E. Neilson, W. R. Webber, C. H. Kable, Horace Plummer, D. E. Biggs, J. Sampson, Wade Pipes, Miles Cooper, Gabriel LaYarre, K. Roald, Allan H. Reid, Fred Baker, Arthur Ulvastedt, M. H. Schmeer, Albert Gerlach, Ben Smith, C. R. Butchen, F. J. Zuber, J. A. Fennell, W. Gerke, R. Logan, James M. Rodda, L. Meuss, Don Dougan, C. Collins, E. D. Nicol, R. Barrett, Frank Sharp, Charley James, Rollin Boles, R. B. Morden, Geo. Kotchik, C. Kaufman, James Conn, Frank Roberts, Neil Kocken-doerfer, D. W. Edmundson, Morgan Hartford.

Total—84.

Mr. Stanton moved that all members of the Chapter be nominated as delegates and alternates to the National Convention of the A. I. A. Seconded and carried.

The following report of the nominating committee was read:

President—Leslie D. Howell.
Vice-President—Geo. H. Jones.
Secretary—Roi L. Morin.
Treasurer—Joseph W. Heiler.
Trustee—John Schneider.

Mr. Tucker called upon Pietro Belluschi to introduce the guest speaker of the evening, Signoro Luigi Tomasini, a brother architect sent to this country by Premier Mussolini to make a study of our architecture and building methods. Signoro Tomasini gave a very impassioned dissertation on his observations of our architecture and the intricate method in which the business of building construction is handled in our country.

After Signoro Tomasini's address, the meeting was

somewhat disrupted, due to the reaction caused by his remarks, and shortly thereafter the meeting was adjourned.

Committee Memberships for 1938

The revised committee arrangements, as defined by the new chapter by-laws recently approved by the Institute, are as follows:

(a) Committee on Memberships

"It shall be the duty of this committee to foster a consistent growth in the Institute memberships, the associateships and the junior associateships of this Chapter."

Schneider (ex-officio) Chairman, Jacobberger, Baer, Wick, Marsh, Morin.

(b) Committee on the Practice of Architecture

"It shall be the duty of this committee to consider matters within the profession, particularly the relation of principals and draftsmen and the encouragement of ever better standards for drawings, specifications and documents, the promotion of more effective building and safety codes, and the standardization of methods of cost accounting."

Herzog Chairman, Wallwork, I. Smith, Allyn, Cash, Heiler (ex-officio).

(c) Committee on Relations with the Construction Industry

"It shall be the duty of this committee to foster a cooperative relationship between architects and the contractors, the producers and dealers in building materials and equipment, draftsmen employed by them, the labor that constructs buildings and other structures, and the persons and institutions that furnish money therefor, in order to promote and maintain efficient and economical building operations."

Jacobberger Chairman, Brookman, Hayslip, Holford, Hinson, Jones (ex-officio).

(d) Committee on Public Relations

"It shall be the duty of this committee to promote the usefulness of the profession and this Chapter to the various governmental bureaus and agencies having charge of the planning and designing of public buildings and monuments and their environs; to promote the employment of architects in private practice to plan and design such public works; to cooperate with the Committee on the Practice of Architecture and with the legislative committee of the State Association member of this state to forward state-wide and local legislation that will promote the welfare of the profession and the construction industry and the public health and welfare, particularly as relating to buildings and the areas about them."

Aandahl Chairman, Church, Tucker, Fritsch, Perring, Knighton.

(e) Committee on Education and Registration

"It shall be the duty of this committee to cooperate with The Institute committees on education and on registration and with the state board of architectural examiners to promote higher aesthetic, scientific and practical qualifications of those engaged or about to engage in the profession within this Chapter's territory, to formulate plans whereby the public appreciation of the arts of design will be enhanced, and to maintain effective contacts with the schools of architecture within the territory of this Chapter."

Stanton Chairman, Legge, Foulkes, E. Lawrence, Willcox.

(f) Committee on Public Information

"It shall be the duty of this committee to cooperate with the similar committee of The Institute, and, in conformity with its program, to formulate the general publicity programs of this Chapter, prepare matter for the press, and develop methods of promulgating such publicity."

M. Fritsch Chairman, Doty, Hilgers, Sundeleaf, Wolff, DeYoung, Johnston (ex-officio).

(g) Committee on Allied Arts & Exhibitions

"It shall be the duty of this committee to foster and promote an ever closer relationship between architects and sculptors, painters, and other artists practicing the arts of design allied with architecture."

MODERNIZED PRODUCTS

Brief Notes on New Materials and Equipment in the Building Industry.

16. ENAMEL

The American Enameler is the title of a very fine little booklet just issued by the Porcelain Enamel & Manufacturing Company. It perfectly illustrates the uses of good enamel, and the progress that has been made in the important product relative to modern building. The coupon sent to this publication will insure your copy.

17. PLUMBING

The Mueller Company are issuing their interesting and enlightening small newspaper which they have named Mueller Record. There will be found here much of vital interest in the advances of modern plumbing equipment. Send in the coupon for your copy.

18. FLOORING

The Tams Silica Company—Flooring Division, have put out a broadside illustrative of their new product "Floorstone," and other of their flooring products.

19. "STORM SEAL"

United States Steel Corporation have issued a broadside delineating their new product "Storm Seal." The coupon will bring you a copy of this new and important building product.

20. LIGHTING FIXTURES

Beardslee Chandelier Manufacturing Company offer a new catalogue and fully descriptive brochure on all types of lighting fixtures which they have titled "Lighting Styled By Beardslee;" this will prove a very interesting item to architects as well as contractors and the coupon will assure you of an early copy.

21. TEMPERATURE

A new method of cooling any room in which a table can be placed is being introduced by the Kisco Company; this new product in building equipment is called a "Cool Circle-Ator Table." A broadside illustrates and describes this product.

22-23. PLUMBING FIXTURES

The well known house of Crane have issued two beautiful brochures in color entitled "Utility Made Beautiful" and "For the Home of Today;" these contain excellent illustrations and interesting text dealing with modern plumbing fixtures; send the coupon for your copies early.

24. NICKEL

"Nickelsworth" is the title of a pamphlet issued by The International Nickel Company. The coupon will bring your copy in an early mail.

25. GAS ENGINES

Convertible Diesel and Gas Engines are illustrated in a pamphlet from Fairbanks, Morse & Company. This should be of interest to engineers and contractors. Send for a copy.

25. SHOWERS

The Henry Weis Manufacturing Company have put out a very well done brochure illustrating and giving full particulars concerning their cabinet showers for homes of all sizes, as well as clubs and other public and semi-public buildings.

27. FURNACE

An industrial furnace for treating ores, etc., is illustrated in the new booklet just issued by the Pacific Foundry Company. The furnace is Nichols Herreshoff Multiple Hearth Furnace. Send in the coupon for a copy.

28. PLYWOOD SIDING

The Harbor Plywood Corporation have recently published a new "Harbordata" leaflet, containing valuable information and illustrations of "HARBORSIDE"—the wide-panel siding made of plywood and with fir or redwood facings. Mark the coupon on this page for your copy.

29. CORROSIRON

The latest bulletin of Pacific Foundry Company on how to overcome corrosion where drain pipes and fittings are used. The bulletin gives you the proper specifications. Fill out the coupon below.

30. FERRO PORCELAIN

An outstanding material for achieving striking effects in modern design. Store owners in particular benefit by using this material. Mark the coupon and receive latest information about this rich, new material.

31. KRAFTILE

Something new for bath rooms, kitchens, etc. In colors to satisfy the most fastidious. Mark the coupon.

FREE FOR THE ASKING

Check items on coupon, paste on letter head or postal card, and mail to Architect and Engineer.

Architect and Engineer
68 Post Street
San Francisco, Calif.

Please send me literature on the following items as checked below. This request places me under no obligation.

- | | |
|--------------------------------|-----------------------------|
| 16 <input type="checkbox"/> | 24 <input type="checkbox"/> |
| 17 <input type="checkbox"/> | 25 <input type="checkbox"/> |
| 18 <input type="checkbox"/> | 26 <input type="checkbox"/> |
| 19 <input type="checkbox"/> | 27 <input type="checkbox"/> |
| 20 <input type="checkbox"/> | 28 <input type="checkbox"/> |
| 21 <input type="checkbox"/> | 29 <input type="checkbox"/> |
| 22-23 <input type="checkbox"/> | 30 <input type="checkbox"/> |
| | 31 <input type="checkbox"/> |

My Name

Name of Company

Street

City

State

Logan Chairman, Belluschi, Dougan, Barnes, Dukehart, A. Lawrence, Haims.

(h) Committee on Civic Design

"It shall be the duty of this committee to foster and encourage better city and regional planning, site planning and low priced housing, to formulate plans for beautifying the communities and roadsides within the territory of this Chapter, and to cooperate with public and other agencies having such matters in charge."

Parker Chairman, Johnson, Whitney, Whitehouse, Forrest.

(i) Special Entertainment Committee

Not defined in the By-Laws.

Schneider Chairman, Turner, Wick, Zeller, Harrington, Wardner, Angell, Wright.

(j) "Highlands" Committee

Hemenway Chairman, Johnston, Belluschi, Legge, Foulkes.

OREGON CHAPTER MARCH MEETING

The regular meeting of Oregon Chapter was held March 15 at Hilaire's restaurant, Portland.

After dinner the meeting was called to order by Vice-president Jones, and a most interesting and instructive sound-film, entitled "A Century of Bridges," was presented through courtesy of John A. Roebling & Sons.

Secretary Morin reported that the Chapter's delegates to the New Orleans Convention would be Messrs. Whitehouse and Crowell.

The secretary read a letter from Portland Chapter, A.G.C., concerning two resolutions passed at their annual convention in Seattle (1) petitioning architects to limit the alternates in bidding, and (2) giving the full support of the A.G.C. to decentralizing the designing of government buildings to require the employment of private architects. The secretary was instructed to frame a suitable reply.

In the absence of President Howell, Mr. Heims reported on an extensive building promotional campaign shortly to be instituted by the Oregon Journal.

Discussion by Herzog and Jacobberger on proposed revision of the Building Code. Vice-president Jones requested that all Chapter members give Mr. Plummer their full cooperation when he calls with questionnaire.

M. Fritsch read letter from Mr. Converse, local agent for The Architect and Engineer of San Francisco, stating that club subscriptions for that publication are available at \$1.50 per year (regular price \$3.00) if undertaken through the Chapter.

WASHINGTON ARCHITECTS SOCIETY

Twenty-five members of the Washington State Society of Architects heard M. E. Roberts, field representative of the Federal Housing Administration, explain principal features of the new FHA act extending mortgage insurance to cover 90% loans and reviving modernization financing, at the monthly meeting held Thursday evening, March 10. Three new members, Lowell V. Casey, Howard H. Riley and E. Wellington, were welcomed to the society.

BOOK REVIEWS

PLASTICS, In The Home Workshop, and In The School: By A. J. Lockrey; Governor Publishing Co., New York City, N. Y. Price: \$2.50.

This is a book for schools keeping up with the advances of modern education. It is a book that growing children as well as adults who like to make useful and interesting things, will find a treasure trove of fascinating material. Resin plastics are the basis for this work and their casting and treatment form the text of the book. Objects of considerable beauty can be made from this very interesting material and it is no idle boast to state that it is one of the most popular of modern craft mediums.

* * *

SHEET METAL WORK: By William Neubecker; American Technical Society; Drexel Ave. at 58th, Chicago, Ill. Price: \$2.50.

The great importance attached to the sheet metal industry in this country needs little mention here. It is one of the major building industries and as such good text and reference volumes dealing with its many phases are always welcome to the technical worker, as well as to the contractor and architect. This new book will amply repay any purchaser for his outlay, in the value of the reference material contained and the clear and concise illustrated details.

* * *

IT'S FUN TO BUILD THINGS: By W. T. R. Price; Hillman-Curl Co., 66 Fifth Ave., New York. Price \$1.50.

This rather unique little book should prove a God-send to those who have a small shop at home or even if they haven't they probably will have before they've finished reading it. The book is well written, entertaining, non-technical and comprehensive. From it one can make good-looking cupboards, panels, window seats, and a host of other attractive and useful pieces of home furniture.

* * *

GLASS IN MODERN CONSTRUCTION: The Pittsburgh Glass Institute; Charles Scribners Sons, New York City, N. Y.

One of the finest books that has come to the attention of the Review Editor for some time. Here one really sees the possibilities of glass in modern use. The beauty that is in glass in its judicious use and the harmony that can be obtained by installing glass in private as well as public buildings.

The Pittsburgh Glass Institute should certainly be complimented upon their sponsoring the movement to place fine glass and its numberless uses before the architectural profession and those people interested in finer building from the lay standpoint of sheer beauty, strength and utility.

ARCHITECTS' BULLETIN

Issued For

THE STATE ASSOCIATION OF CALIFORNIA ARCHITECTS Northern Section

STATE ASSOCIATION MEMBER
OF THE
AMERICAN INSTITUTE OF ARCHITECTS
Editor

Harris C. Allen

Address all communications for publication
in the Bulletin to the Editor (Harris C.
Allen) 557 Market Street, Room 218, San
Francisco, California.

Board of Control

Harris C. Allen Otto G. Hintermann
Harry Michelsen Ellsworth E. Johnson
Chester H. Miller

State Association Officers

Harry M. Michelsen, San Francisco, President
George D. Riddle, Los Angeles, Vice-Pres.
Louis N. Crawford, Santa Maria, Secretary
Otto G. Hintermann, San Francisco, Treas.

Regional Director, A. I. A.

Albert J. Evers, San Francisco

Representative of Regional Director, Southern California

Gordon B. Kaufmann, Los Angeles

Executive Board—Northern Section Officers

Harry M. Michelsen.....President
Gwynn Officer.....Vice-President
Ellsworth E. Johnson.....Secretary
Otto G. Hintermann.....Treasurer

Directors

Walter E. Baumberger William G. Merchant
Harry J. Devine Frederick H. Reimers

Executive Board—Southern Section

Officers

George D. Riddle.....President
Gordon B. Kaufmann.....Vice-President
Louis N. Crawford.....Secretary
Robert H. Orr.....Treasurer

Directors

Harold C. Chambers Lester G. Hibbard
A. M. Edelman W. P. Lodge

S. B. Marston

Advisors—Northern Section

Harris C. Allen Edward R. French, Jr.
G. F. Ashley Arthur F. Dodman
J. K. Ballantine Joseph Loselenn
Wayne S. Hertzka David H. Horn
Conrad T. Kett Robert Stanton
W. I. Garren Charles S. McKenzie
W. G. Merchant Henry C. Collins
Thomas E. Pring Leo J. Sharps
Vincent Raney Carl F. Gromme
F. H. Reimers C. C. Dakin
Edward O. Blodgett F. T. Georgeson
George P. Simonds Ralph D. Taylor
Gwynn Officer

WHY THE ASSOCIATION

RECENTLY a frank, and even friendly, letter was received by President Michelsen which was perhaps typical of a not uncommon, if not often expressed, point of view about the Association and its need or usefulness. It would be impossible to include all reasons, objectives and accomplishments in one letter of answer. Mr. Michelsen did not attempt to do more than briefly outline some of the "high lights" without reviewing the history of the Association, its original purpose of supporting the State Board of Architectural Examiners, its achieved policy of co-ordinating activities with the Institute whereby the Chapters handle professional practice, education and aesthetics while the Association takes care of local problems, legislation, business and publicity. The letter and President Michelsen's reply follow:

JOHN DOE, ARCHITECT

Milpitas, California

Mr. Harry M. Michelsen, President,
State Association of California Architects,
San Francisco, California.

Dear Mr. Michelsen:

Last October we elected an Advisor for this district. He was not present at the convention, although it was a foregone conclusion that he would be "it."

According to my best information, there has never been a meeting called here, nor have I been advised of any in this Section.

Why should we have the office, or perhaps I might say, why the Association? Seriously, I cannot see the benefits either directly or indirectly. If it's the fault of the Advisor in any year, he should be recalled. This is not directed at our present incumbent, as he is a friend of mine, but I sincerely feel that the Association has never functioned to its fullest capacity. I shall be glad to contribute time, energy and money to it, if, as, and when it gets out of the doldrums. Please pardon the note—no personal reference at all.

(Signed) John Doe.

P. S. I have attended a number of the Conventions, enjoyed them—only to become thoroughly disgusted six months later.

John Doe, Architect,
Milpitas, California.

Dear Mr. Doe:

Your letter of March 14 expresses a point of view which is quite understandable.

It is often hard to see what benefits the Association does secure for the individual architect. The same thing is true of the Institute; but over its 80-year life it has maintained a standard for the profession which has protected individuals on countless occasions.

The A.I.A. Committee on State Organizations is now preparing a document on standards of practice, which will be available and useful to all architects, explaining to the lay public about practice, selection and fees. This is directly due to our affiliation with the Institute.

Our Association has not always been successful in positive legislative efforts, but it has certainly prevented many injurious acts from being passed. A committee and a retained adviser are constantly on the watch for such items, often hidden among the thousands of bills introduced. Much local municipal legislation has been favorably affected by the Association.

Our advisory committee has co-operated with the State Division of Architecture in making improved rulings to clarify the Field and Riley Acts, of undoubted assistance to architects.

Since we have been organized, much better relations have developed between architects and engineers, general contractors and producers—tending towards a better organized building industry, and a united front in legislative campaigns.

Many more activities could be mentioned; new ones are constantly being presented to the Executive Boards. We are convinced that a State organization representing all certificated architects is absolutely essential for the protection and progress of the profession. "Advisors" are provided in this structure, not only to initiate action, but to receive suggestions, complaints, and requests for advice, information and assistance, from the other architects in their districts.

I feel sure that any constructive idea, or criticism, that you may offer to your local Advisor will be given serious consideration by your Executive Board, and if you yourself take part in any Association activities you will become satisfied that it is a necessary and valuable instrument for professional unity and advancement. Enclosed is one of the several publications of the Association—"Putting Value into Buildings."

Very sincerely yours,

Henry M. Michelsen
President of the State Association
of California Architects.

LOCAL HOUSING AUTHORITIES The State Legislature has passed and the Governor has signed the necessary State Acts enabling California municipalities to create Housing Authorities to participate in the Federal program.

Both San Francisco and Oakland have been anticipating this enactment, and the Association has been in correspondence with the two administrations, in regard to the appointment of suitable members and the general policy to be pursued. It is now considered essential that the administrative staff should include an architect, as well as other qualified technicians. A cordial welcome was given by Mayor Rossi to a committee consisting of H. M. Michelsen, Warren Perry, Albert J. Evers, Geoffrey Bangs, and Harris Allen, representing architectural organizations, and our offer of assistance and advice was given assurance of favorable consideration. A conference will also be held with the Oakland administration. Our special committee, a joint activity of Chapter, Association and District Society, will keep in touch with developments and report to the profession accordingly.

F. H. A. MEETINGS Meetings have been scheduled in San Francisco, Los Angeles, Portland and Seattle, to which all listed architects have been invited by the American Institute of Architects to be thoroughly informed of the very promising opportunities now open to architects through the new National Housing Act. Similar meetings were arranged throughout the country, under the belief that the profession should become a leading, substantial factor in promoting large-scale housing projects on the soundest basis. Harris Allen, F.A.I.A., has been appointed Architectural Consultant, F.H.A., for Region 6, covering Washington, Oregon, California, Nevada and Arizona, and will conduct meetings

in this region. A complete report of all these meetings will be made at the Institute Convention in New Orleans, starting April 19.

SUBSCRIPTION DUES Our efficient Treasurer, Otto Hintermann, is out for a record. He already has one; for the subscription payments for 1938 are already more than during the entire previous year. But he hopes and expects to double last year's number. Architects are more and more coming to realize that the Association has something to offer the individual, as well as safeguarding the interests of the whole profession. At every meeting (monthly or oftener) of the Executive Board new and desirable activities are proposed, many of which it is impossible to undertake for lack of sufficient funds. A small reserve fund is being laid aside regularly, for legislative and other needs; balance of income is very carefully and conscientiously budgeted and an object must be worthy indeed to get by the budget guarded by our Comptroller General, Otto the Hinder Man. Which is another way of saying that the more subscription dues are paid, the more work for professional progress can be undertaken.

WORLD'S TALLEST CHIMNEY

(Concluded from Page 8)

under the bottom steel of the base and project upward into the shell a sufficient distance to provide ample bond between the dowels and the concrete. Reinforcement consists of vertical bars and horizontal rings to take up tension due to wind load and vertical and horizontal temperature stresses. Additional reinforcing bars are provided at the sides and at top and bottom of the flue opening, which measures 12 feet 2 inches by 17 feet 6 $\frac{1}{8}$ inches and is 34 feet 10 $\frac{3}{4}$ inches above the base.

The column was built with the contractor's patented all-steel forms in sections 7 feet 6 inches high. A platform extending outward from the shell and short sections of suspended scaffolding were provided for the use of the workmen in making adjustments to the forms and finishing the concrete surface. The forms were periodically raised by chain blocks suspended from the "hammerhead" crane arrangement on top of the steel tower carried about 50 feet in advance inside the chimney, and concrete and men were hoisted to the opening platform by a skip operating in the center of the tower. This tubular tower, constructed entirely of pipe, was erected within the stack foot by foot as it rose, increasing efficiency and safety. Upon the completion of the job, the tower was taken down piece by piece for use on the next job. The skip was actuated by an electric-driven hoist.

To provide access to the interior of the shaft a clean-out door is available at the base, and at a level 150 feet from the ground there is installed a steel platform extending around one-third the circumference of the shell.

Estimator's Guide

Giving Cost of Building Materials, Wage Scale, Etc.

Amounts given are figuring prices and are made up from average quotations furnished by material houses to San Francisco contractors. 3% Sales Tax on all materials but not labor.

All prices and wages quoted are for San Francisco and the Bay District. There may be slight fluctuation of prices in the interior and southern part of the state. Freight cartage, at least, must be added in figuring country work.

Bond—1/2% amount of contract.

Brickwork—

Common, \$40 to \$45 per 1000 laid, (according to class of work).

Face, \$100 to \$110 per 1000 laid, (according to class of work).

Brick Steps, using pressed brick, \$1.25 lin. ft.

Brick Veneer on frame buildings, \$.75 sq. ft.

Common f.o.b. cars, \$14.00 at yard. Cartage extra.

Face, f.o.b. cars, \$45.00 to \$50.00 per 1000, carload lots.

HOLLOW TILE FIREPROOFING (f.o.b. job)

3x12x12 in.	\$ 84.00 per M
4x12x12 in.	94.50 per M
6x12x12 in.	126.00 per M
8x12x12 in.	225.00 per M

HOLLOW BUILDING TILE (f.o.b. job)

carload lots.	
8x12x5/2 \$ 94.50	
6x12x5/2 73.50	

Building Paper—

1 ply per 1000 ft. roll	\$3.50
2 ply per 1000 ft. roll	5.00
3 ply per 1000 ft. roll	6.25
Brownskin, 500 ft. roll	4.50
Brownskin, Pro-techomat, 1000 ft. roll	9.00
Siskelraft, 500 ft. roll	5.00
Sash cord com. No. 7	\$1.20 per 100 ft.
Sash cord com. No. 8	1.50 per 100 ft.
Sash cord spot No. 7	1.90 per 100 ft.
Sash cord spot No. 8	2.25 per 100 ft.
Sash weights cast iron, \$50.00 ton.	
Nails, \$3.50 base.	
Sash weights, \$45 per ton.	

Concrete Work (material at San Francisco bunkers)—Quotations below 2000 lbs. to the ton, \$2.00 delivered.

No. 3 rock, at bunkers.....	\$1.45 per ton
No. 4 rock, at bunkers.....	1.45 per ton
Elliott top gravel, at bunkers.....	2.10 per ton
Washed gravel, at bunkers.....	1.45 per ton
Elliott top gravel, at bunkers.....	2.10 per ton
City gravel, at bunkers.....	1.45 per ton
River sand, at bunkers.....	1.40 per ton
Delivered bank sand.....	1.00 cu. yd.

Note—Above prices are subject to discount of 2% per ton on invoices paid on or before the 10th of month, following delivery.

SAND

Del Monte, \$1.75 to \$3.00 per ton.
Fan Shell Beach (car lots, f.o.b. Lake Majella), \$2.75 to \$4.00 per ton.

Cement (paper sacks) \$3.00 bbl., warehouse or delivery.

Car-load lots delivered \$2.70, f.o.b. cars \$2.52

(Cloth sacks) \$3.00 bbl.

Rebate 10 cents bbl. cash in 15 days.

Atlas White } 1 to 100 sacks, \$1.50 sack,
Calaveras White } warehouse or delivery; over 100
Medusa White } sacks, \$1.25; 2% discount 10th of month.

Forms, Labors average \$40.00 per M.

Average cost of concrete in place, exclusive of forms, 35c or cu. ft.; with forms, 60c.

4-inch concrete basement floor

.....12 1/2c to 14c per sq. ft.

Rat-proofing7 1/2c

Concrete Steps\$1.25 per lin. ft.

Dampproofing and Waterproofing—

Two-coat work, 20c per yard.

Membrane waterproofing—4 layers of saturated felt, \$4.50 per square.

Hot coating work, \$1.80 per square.

Medusa Waterproofing, 15c per lb., San Francisco Warehouse.

Tricocel waterproofing.

Electric Wiring—\$12.00 to \$15.00 per outlet for conduit work (including switches).

Knob and tube average \$3.50 per outlet.

Elevators—

Prices vary according to capacity, speed and type. Consult elevator companies.

Average cost of installing an automatic elevator in four-story building, \$26.00; direct automatic, about \$27.00.

Excavation—

Sand, 60 cents; clay or shale \$1 per yard.

Teams, \$12.00 per day.

Trucks, \$22 to \$27.50 per day.

Above figures are an average without water. Steam shovel work in large quantities; less; hard material, such as rock, will run considerably more.

Fire Escapes—

Ten-foot galvanized iron balcony, with stairs, \$115 installed on new buildings; \$140 on old buildings.

Floors—

Composition Floors—22c to 40c per sq. ft.

In large quantities, 16c per sq. ft. laid.

Mosaic Floors—80c per sq. ft.

Duraflex Floors—23c to 30c sq. ft.

Rubber Tile—50c to 75c per sq. ft.

Terazzo Floors—45c to 60c per sq. ft.

Terazzo Steps—\$1.60 lin. ft.

Hardwood Flooring (delivered to building)—

1 1/2x2 1/4" T & G Maple.....	\$ 88.00 M ft.
1 1/2x2 1/4" T & G Maple.....	115.00 M ft.
7/8x3 1/2" sq. edge Maple.....	100.00 M ft.

	1 1/2x2 1/4"	3/4x2"	5/8x2"
	T & G	T & G	Sq. Ed.
Clr. Qtd. Oak	\$120.00 M	\$ 82.50 M	\$110 M
Sel. Qtd. Oak	99.00 M	69.50 M	84 M
Clr. Pla. Oak	106.00 M	74.50 M	86 M
Sel. Pla. Oak	97.00 M	62.50 M	76 M
Clear Maple	111.00 M	100.00 M	
Laying & Finishing	14c ft.	12c ft.	10c ft.
Wage—Floor layers, \$10.00.			

Note—Above quotations are all board measure except last column which is sq. ft.

Glass (consult with manufacturers)—

Double strength window glass, 20c per square foot.

Plate 75c per square foot (unglazed) in place, \$1.00.

Art, \$1.00 up per square foot

Wire (for skylights), 40c per sq. foot.

Obscure glass, 30c square foot.

Glass bricks, \$2.40 per sq. ft., in place.

Note—If not stipulated add extra for setting.

Heating—

Average, \$1.90 per sq. ft. of radiation, according to conditions.

Warm air (gravity) average \$40 per register.

Forced air, average \$60 per register.

Iron—Cost of ornamental iron, cast iron etc., depends on designs.

Lumber (prices delivered to bldg. site).

No. 1 common	\$29.00 per M
No. 2 common	27.00 per M
Select O. P. common	34.00 per M
2x4 No. 3 floor lumber	24.00 per M
1x4 No. 2 flooring VG	55.00 per M
1x4 No. 3 flooring VG	47.00 per M
1x6 No. 2 flooring VG	60.00 per M
1 1/4x4 and 6, No. 2 flooring	60.00 per M

Slash grain—

1x4 No. 2 flooring	\$43.00 per M
1x4 No. 3 flooring	40.00 per M
No. 1 common run T & G	30.00 per M
Lath	5.25 per M

Shingles (add cartage to price quoted)—

Redwood, No. 1	\$1.10 per bdle.
Redwood, No. 290 per bdle.
Red Cedar	1.10 per bdle.

Milkwork—Standard.

O. P., \$85.00 per 1000. R. W., \$90.00 per 1000 (delivered).

Double hung box window frames, average with trim, \$6.50 and up, each.

Doors, including trim (single panel, 1 3/4 in. Oregon pine) \$8.00 and up, each.

Doors, including trim (five panel, 1 3/8 in. Oregon pine) \$6.00 each.

Screen doors, \$3.50 each.

Patent screen windows, 25c a sq. ft.

Cases for kitchen pantries seven ft. high per lineal ft., \$8.00 each.

Dining room cases, \$9.00 per lineal foot. Rough and finish about 75c per sq. ft.

Labor—Rough carpentry, warehouse heavy framing (average), \$17.50 per M.

For smaller work average, \$35.00 to \$45.00 per 1000.

Marble—(See Dealers)

Painting—

Two-coat work	36c per yard
Three-coat work	50c per yard
Cold Water Painting	10c per yard
Whitewashing	4c per yard
Turpentine, 65c per gal., in 5 gal. cans, and 55c per gal. in drums.	
Raw Linseed Oil—97c gal. in bbls.	
Boiled Linseed Oil—\$1.00 gal. in bbls.	
Medusa Portland Cement Paint, 20c per lb.	

Pioneer or Dutch Boy White Lead in Oil (in steel kegs).

1 ton lots, 100 lbs. net weight	10 1/4c
500 lbs. and less than 1 ton lots	10 1/2c
Less than 500 lb. lots	11c

Pioneer or Dutch Boy Red Lead and Litharge (in steel kegs).

1 ton lots, 100 lb. kegs, net weight	10 1/4c
500 lbs. and less than 1 ton lots	10 1/2c
Less than 500 lb. lots	11c

Pioneer Red Lead in Oil (in steel kegs)

1 ton lots, 100 lb. kegs, net weight	11 1/4c
500 lbs. and less than 1 ton lots	11 1/2c
Less than 500 lb. lots	12c

Note—Accessibility and conditions cause some variance in costs.

Patent Chimneys—

6-inch	\$1.25 lineal foot
8-inch	1.75 lineal foot
10-inch	2.25 lineal foot
12-inch	3.00 lineal foot

Plastering—Interior—

1 coat, brown mortar only, wood lath	Yard \$0.75
2 coats, lime mortar hard finish, wood lath	.80
2 coats, hard wall plaster, wood lath	.85

3 coats, metal lath and plaster	1.30
Keene cement on metal lath	1.30
Ceilings with 3/4 hot roll channels metal lath	.75
Ceilings with 3/4 hot roll channels metal lath plastered	1.50
Single partition 3/4 channel lath 1 side	.85
Single partition 3/4 channel lath 2 sides 2 inches thick	1.50
4-inch double partition 3/4 channel lath 2 sides	1.30
4-inch double partition 3/4 channel lath 2 sides plastered	3.00

Plastering—Exterior—

2 coats cement finish, brick or concrete wall	\$1.00
2 coats Calaveros cement, brick or concrete wall	1.35
3 coats cement finish, No. 18 gauge wire mesh	1.50
3 coats Calaveros finish, No. 18 gauge wire mesh	1.75

Wood lath, \$7.50 to \$8.00 per 1000.	
2.5-lb. metal lath (dipped)	.17
2.5-lb. metal lath (galvanized)	.20
3.4-lb. metal lath (dipped)	.22
3.4-lb. metal lath (galvanized)	.28
3 1/2-inch hot roll channels, \$72 per ton.	
Finish plaster, \$18.90 ton in paper sacks.	
Dealer's commission, \$1.00 off above quotations.	
\$13.85 (rebate 10c sack).	
Lime, f.o.b. warehouse, \$2.25 bbl.; cars, \$2.15	
lime, bulk (ton 2000 lbs.), \$16.00 ton.	
Wall Board 5 ply, \$50.00 per M.	
Hydrate Lime, \$19.50 ton.	

Plasterers Wage Scale	\$1.25 per hour
Lathers Wage Scale	1.25 per hour
Helpers Wage Scale	1.10 per hour
Compositon Stucco—\$1.80 to \$2.00 sq. yard (applied).	

Plumbing—

From \$70.00 per fixture up, according to grade, quantity and runs.

Roofing—

"Standard" tar and gravel, \$6.50 per sq. for 30 sqs. or over.
Less than 30 sqs. \$7.00 per sq.
Tile, \$20.00 to \$35.00 per square.
Redwood Shingles, \$7.50 per square in place.
Copper, \$16.50 to \$18.00 per sq. in place.

Cedar Shingles, \$8.00 per sq. in place.
Recoat, with Gravel, \$3.00 per sq.
Asbestos Shingles, \$15 to \$25 per sq. laid.
Slate, from \$25.00 to \$60.00 per sq. laid according to color and thickness.

Sheet Metal—

Windows—Metal, \$1.75 a sq. foot.
Fire doors (average), including hardware \$1.75 per sq. ft.

Skylights—(not glazed)

Copper, 90c sq. ft. (flat).
Galvanized iron, 30c sq. ft. (flat).
Vented hip skylights 60c sq. ft.

Steel—Structural

\$120 ton (erected), this quotation is an average for comparatively small quantities. Light truss work higher. Plain beams and column work in large quantities \$90 to \$100 per ton.

Steel Reinforcing—

\$80.00 to \$120.00 per ton, set.

Stone—

Granite, average, \$6.50 cu. foot in place
Sandstone, average Blue, \$4.00. Boise \$3.00 sq. ft. in place.
Indiana Limestone, \$2.80 per sq. ft. in place.

Store Fronts—

Copper sash bars for store fronts, corner center and around sides, will average 75c per lineal foot.
Note—Consult with agents.

Tile—Floor, Wainscot, etc.—(See Dealers)

Asphalt Tile—18c to 28c per sq. ft. installed.

Venetian Blinds—

40c per square foot and up. Installation extra.

THE BUILDERS' EXCHANGE OF SAN FRANCISCO STANDARD WAGE SCALE

For mechanics employed on construction work in the Bay Region. Effective September 1, 1937

CRAFT	Journeymen Mechanics
Asbestos Workers	\$ 8.00
Bricklayers (8h-5d)	10.50
Bricklayers' Hodcarriers (6h-5d)	6.75
Cabinet Workers (Outside) (5d)	9.00
Calsson Workers (Open)	6.40
Carpenters (8h-5d)	10.00
Cement Finishers (8h-5d)	10.00
Cork Insulation Workers (8h-5d)	9.00
Electric Workers (8h-5d)	11.00
Electrical Fixture Hangers	8.00
Elevator Constructors	10.40
Engineers, Portable & Hoisting	9.00
Glass Workers (8h-5d)	9.68
Hardwood Floormen	9.00
Housesmiths, Architectural Iron (Shop) (8h-5d)	9.00
Housesmiths, Architectural Iron (Outside) (8h-5d)	10.00
Housesmiths, Reinforced Concrete or Rodmen (8h-5d)	10.00
Iron Workers (Bridge and Structural) Including Engineers (8h-5d)	12.00

CRAFT	Journeymen Mechanics
Laborers, Building (8h-5d)	\$ 6.00
Laborers, Common (8h-5d)	6.00
Lathers, Channel Iron (6h-5d)	9.00
Lathers, All Others	9.00
Marble Setters (8h-5d)	10.50
Marble Setters' Helpers (8h-5d)	5.00
Milwrights	9.00
Model Makers (\$1.50 per hr-6h)	11.00 per hr
Modelers (\$2 per hr-6h)	12.00
Model Casters	7.20
Mosaic and Terrazzo Workers (Outside)	9.00
Painters (7h-5d)	8.50
Painters, Varnishers and Polishers (Outside)	9.00
Pile Drivers and Wharf Builders	9.00
Pila Drivers' Engineers	10.00
Plasterers (6h-5d)	10.00
Plasterers' Hodcarriers (6h-5d)	7.50
Plumbers (8h-5d)	11.00
Roofers, Composition (8h-5d)	9.00
Roofers, All Others (8h-5d)	8.00
Sheet Metal Workers (8h-5d)	10.00
Sprinkler Fitters	10.00

CRAFT	Journeymen Mechanics
Steam Fitters (8h-5d)	\$11.00
Stair Builders (8h-5d)	9.00
Stone Carriers, Soft and Granite (8h-5d)	8.00
Stone Setters, Soft and Granite	12.00
Stone Derricksmen	9.00
Tile Setters (8h-5d)	11.00
Tile Setters' Helpers (8h-5d)	6.50
Title, Cork and Rubber (8h-5d)	9.00
Welders, Structural Steel Frame on Buildings	11.00
Welders, All Others on Buildings	9.00
Dump Truck Drivers, 2 yards or less	6.00
Dump Truck Drivers, 3 yards	6.50
Dump Truck Drivers, 4 yards	7.00
Dump Truck Drivers, 5 yards	7.00
Dump Truck Drivers, 6 yards	7.50
Truck Drivers of Concrete Mixer Trucks: 2 yards or less	6.50
3 yards	7.00
4 yards	7.50
5 yards	7.50
6 yards	8.00

GENERAL WORKING CONDITIONS

- Eight hours shall constitute a day's work for all crafts except as otherwise noted.
- Plasterers' Hodcarriers, Bricklayers' Hodcarriers, Roofers, Laborers, and Engineers, Portable and Hoisting, shall start 15 minutes before other workmen, both at morning and at noon.
- Five days, consisting of not more than eight hours a day, on Monday to Friday inclusive, shall constitute a week's work.
- Transportation costs in excess of twenty-five cents each way shall be paid by the contractor.
- Overtime shall be paid as follows: For the first four hours after the first eight hours, time and one-half. All time thereafter shall be paid

- double time, Saturdays (except Laborers), Sundays and holidays, from 12 midnight of the preceding day, shall be paid double time.
- On Saturday, Laborers shall be paid straight time for an eight-hour day.
- Where two shifts are worked in any twenty-four hours, shift time shall be straight time. Where three shifts are worked, eight hour's pay shall be paid for seven hours on the second and third shifts, allowing one-half hour for lunch.
- All work, except as noted in paragraph 9, shall be performed between the hours of 8 a.m. and 5 P.M.
- In emergencies, or where premises cannot be vacated until the close of business, men then

- reporting for work shall work at straight time. Any work performed on such jobs after midnight shall be paid time and one-half up to four hours of overtime and double time thereafter, provided, that if a new crew is employed on Saturdays, Sundays or holidays which has not worked during the five preceding days, such crew shall be paid time and one-half.
- Recognized holidays to be: New Year's Day, Decoration Day, Fourth of July, Labor Day, Admission Day, Thanksgiving Day, Christmas Day.
- Men ordered to report for work, for whom no employment is provided, shall be entitled to two hours' pay.

EXPERTS DESCRIBE PROGRESS IN CONCRETE HOUSE DESIGN

PROBLEMS confronting two important branches of the concrete construction industry were discussed and analyzed when more than 2,000 concrete contractors and concrete products manufacturers from all parts of the country assembled for their annual joint conventions in Chicago, February 8 to 11.

Convening organizations included the American Concrete Contractors Association, National Concrete Masonry Association, National Cinder Concrete Products Association, and the Cast Stone Institute. It was the second time that concrete contractors and products men held their sessions jointly, the success of which was indicated by the 33 per cent increase in attendance.

Held simultaneously with the conventions was the Concrete Industries Exposition in which 80 exhibitors displayed almost every kind of new concrete equipment and supplies—from form ties and clamps to the latest types of transit mix trucks, concrete block machines and concrete pumps. The success of last year's show brought a 50 per cent increase in the number of exhibitors with the result that 46 per cent more space was occupied. Exhibitors expressed great optimism regarding business prospects as a result of sales closed and prospects developed at this year's exposition.

One of the feature events of the week was the formation of concrete contractors into an organization which was named the American Concrete Contractors Association.

A highlight of the joint session held on the second day was the resolution drawn up by the combined groups endorsing the U. S. Housing Act of 1937 and the National Housing Act.

Copies of this resolution were wired to President Roosevelt, to Administrator Nathan Straus of the U. S. Housing Authority and to Administrator Stewart McDonald of the Federal Housing Administration. Stewart McDonald, commending the action, replied: "Your telegram containing resolutions adopted yesterday is most heartening. The machinery is here for the government to do its part in stimulating home construction. Our success in the long run, however, depends largely upon the whole-hearted voluntary co-operation of such organizations as yours."

Another slant to the housing picture—specifically pertaining to slum clearance as instigated by the United States Housing Authority—was discussed by Ernest M. Culligan, assistant to Administrator Straus, who pointed out the extensive use of concrete in these projects.

Throughout the four convention days, the subject of concrete housing, as the coming market, held an

important place in talks, discussions and round table conferences.

That prospects for contractors and concrete products men are favorable was further corroborated by W. D. M. Allan, Director of Promotion of the Portland Cement Association, who said, "Men in the concrete industry have greater confidence in its future than ever before." He explained how concrete rose from obscurity until today it is an accepted building material with qualities that are recognized by people in all parts of the country. For example, he pointed out, "There were four times as many concrete houses built in 1937 in a recession as in 1927 at the peak of the building boom—when there was a ten and one-half billion dollar total construction market. Relatively sixteen times as many concrete houses in a depression as in the boom. And the concrete industry has only started."

Products men learned of the importance of fitting concrete products to the housing market if they wished to keep in step with rapid advances in house design and construction technique. This was the subject of a paper by E. W. Dienhart, Assistant Manager of the Products Bureau of the Portland Cement Association.

The concrete floor was pointed out as being of equal importance to the development of modern, fire-safe houses. This was described as the coming type of construction for the reason that the cost of building concrete floors had been reduced to a competitive level by the use of precast concrete joists.

Concrete contractors were told of the recent developments in another type of concrete house construction—reinforced concrete—which has been gaining favor rapidly in many sections of the country. In describing these advances, A. L. Rehnquist, reinforced concrete house consultant of the Portland Cement Association, demonstrated an easy method of wall forming in which the concrete walls of a house are built flat on the ground like a sidewalk, then tilted up into position. He also described other forming methods being used successfully today by builders.

A new market for concrete products was described by Albert E. Bill, well-known builder of low-cost concrete masonry houses at Detroit, Mich., who showed that the firesafe concrete home is a profitable enterprise for the operative builder.

In the discussion of advanced methods being used in concrete products manufacture, Benjamin Wilk, Detroit, Mich., described his experience with electric curing. And the practicability of under-cover storage was explained by C. B. Fellabaum, Toledo, Ohio. Eugene B. White, Chicago, Ill., discussed the White-

Steel monolithic method of precast slab construction, while Quentin Twachtman, Irvington, N. Y., told of the use of pre-fabricated sections in wall construction.

A series of demonstrations given before concrete contractors, featured a subject important to modern concrete construction—how to make concrete surfaces beautiful. Three methods of coloring concrete were shown. R. C. Reeves, Holland, Mich., sprayed sample panels to demonstrate how color can be applied with spray guns. Chemical staining and mechanical scoring were demonstrated by R. E. Bishop, Long Island City, New York, and dust-on and integral mix methods of coloring were presented by G. F. Steigerwalt, who is an engineer and housing consultant of the Portland Cement Association. How various textures are produced in reinforced concrete walls was explained by R. E. Copeland, development engineer of the Portland Cement Association.

The vibration of concrete also was demonstrated by A. E. Lindau, Chicago.

Round table discussions held by all groups and an inspection trip through the Underwriters' and Portland Cement Association Laboratories closed the 1938 conventions.

ARCHITECTURAL LEAGUE 52ND EXHIBITION

The Architectural League of New York has issued its Circular of Information which constitutes the invitation to members of the architectural profession and the allied arts to participate in the forthcoming 52nd Annual Exhibition of the League to be held in the Fine Arts Building on West 57th Street in New York from April 18th to May 12th.

This year marks an entirely new type of exhibition in that it is national in scope rather than restricted to New York City and vicinity, with a few exhibits from other parts of the country, as has been the plan in the past. An exhibition of the kind now organized has never been held in this country before. It will cover the interests of architects and allied artists, builders, contractors and producers of building materials.

The country has been divided by the Exhibition Committee into 36 areas, designated by cities, which in turn are grouped into seven sections consisting of Pacific Coast, Rocky Mountain, Middle West, South Atlantic, Far South and South West, New England, and New York City. The various areas are: Seattle, Washington, Portland, Oregon, San Francisco and Los Angeles, in the Pacific Coast Section; Denver and Salt Lake City, in the Rocky Mountain Section; Kansas City, Mo., St. Louis, Mo., Chicago, Ill., Indianapolis, Ind., Minneapolis, Minn., Milwaukee, Wis., Detroit, Mich., Cincinnati, Ohio, Cleveland, Ohio, Columbus, Ohio, Toledo, Ohio, Pittsburgh, Pa., in the Middle West Section; Atlanta, Ga., Baltimore, Md., Washington, D.C., Richmond, Va., Memphis, Tenn., Nash-

ville, Tenn., Chattanooga, Tenn., Palm Beach, Fla., Wilmington, Del., Philadelphia, Pa., in the South Atlantic Section; New Orleans, La., Houston, Texas, Dallas, Texas, Santa Fe, New Mexico, in the Far South and South West Section; Boston, Mass., Providence, R.I., Bennington, Vt., in the New England Section.

In each area an architect has been appointed chairman of a committee for his area. Working with him in nearly every case as members of a central committee, are a sculptor, a painter, and a landscape architect. This committee will organize the exhibit for its area which will be a part of the New York Show. The make-up of the exhibit will be determined entirely by the area committee. This selection of material by each committee is a new approach.

It is already planned that the organization resulting from this year's exhibition will be a nucleus for the 1939 organization. Men active on the area committees will be selected for a national committee for 1939 when the League's exhibition will be made up of work from the entire Western Hemisphere, selected by committees in each country, as is being done this year by areas.

The content of this year's exhibition will be the same kind of material as before, namely, photographs and models of architecture; actual architectural sculpture or facsimiles of pieces installed in buildings; actual decorative paintings incorporated in buildings or otherwise used in connection with architecture; and photographs and models of landscape architecture. There will also be a special gallery for the display of outstanding work in the decorative arts and crafts from all over the country, with emphasis in handicraft work rather than machine or quantity produced objects.

FEDERAL CAMP AT SHASTA

Secretary of the Interior Harold L. Ickes has announced award of contract covering street, driveway, sidewalk, and sewer and water systems for the Government camp at Shasta Dam on the Central Valley project, to the Lowrie Paving Company, Inc., of San Francisco, on its bid of \$45,949.55.

The Government camp at Shasta Dam is located southwest of the dam site and about 14 miles north of Redding, California. With the completion of this contract the camp will be about ready for occupation.

HOUSE AND GARDEN SHOW

Dates of May 14 to 22 are announced for Chicago's annual National House and Garden Exposition. It will be held in the historical Coliseum, scene of many national political conventions, trade shows and exhibitions. Leading architectural, building material, household furnishing and allied groups are cooperating with officials of the show who anticipate an increase in the record attendance of more than 200,000 last year.

DOME WILL HOUSE WORLD'S LARGEST TELESCOPE

UNDER the supervision of a committee of engineers of the California Institute of Technology, workmen shortly will begin installing insulating panels in the 135-foot diameter dome on the summit of Mt. Palomar, near Pasadena, which will house the largest telescope in the world.

The insulating problem faced by the committee was two-fold—maintaining the temperature control necessary to protect the telescope, and providing a modern architectural finish for the interior of the dome surface.

Astronomers plan to keep the building, which will house the telescope beginning sometime in 1940, open to the night air from sunset to dawn. Huge sliding shutters over the opening, which will be 30 feet wide and over 100 feet long, will be closed at dawn, when the atmosphere is coldest, to maintain a low daylong temperature inside. When the shutters are opened in late afternoon, the temperatures inside and outside will thus be about the same. The larger the telescope, the more important it is to avoid temperature changes which might render the telescope unusable for several hours of precious observing time.

The Alfol Company, which has worked out many difficult adaptations of aluminum foil insulation for the U. S. Navy, railroad, bus and marine equipment, aircraft, refrigeration and other equipment applications, as well as for building insulation, solved the insulating problems presented by the dome. They are using a unique all-metal aluminum foil insulation panel, completely enclosed in 5-inch thick pan-shaped trays of light sheet steel covered with a sheet of aluminum on the inside surface. This attractive aluminum surface, satin finished, will form the modern architectural finish of the interior dome surface, set off by the slender lines of the T's which rise from the observation gallery and arch high overhead, converging toward the top of the dome. The panels will form an integral part of the dome structure.

The dome is built up of steel plate, butt-welded together and supported on I beams curved to the radius of the dome and erected in vertical planes. In turn, these I beams are supported by horizontal trusses, carried by larger trusses arching up in circular arcs from the springline of the dome to the large box girders of semi-circular form that frame the dome opening. The insulating panels will be placed in line with the 4 feet deep arching trusses' inside faces to form a ceiling with concave spherical surface which will be 4 feet from the inside surface of the dome plates, except at the very top of the dome, where the insulating ceiling will be flat and will pass horizontally just under the box girders and extend to the sides of the opening.

The panels will be supported by structural T's of aluminum conforming to the curvature of the dome.

Each panel will fit between the stems of the T's, retained by the flange on each side. The side panels, which are about 7 feet high and decrease in width from about 4 feet at the springline to about 2 feet at the flat ceiling, are curved inward to conform to the shape of the dome.

NEW REDWOOD PLYWOOD

A technique for producing beautiful plywood panels with veneers of California redwood has been perfected, and the process is now geared to a production basis. The process was invented in the laboratory of the Harbor Plywood Corporation, Hoquiam, Washington.

Redwood peeler logs from the Hammond Redwood Company on Humboldt Bay, California, are transported to the Northwest plant where, by an exclusive and patented process, they are converted into redwood plywood.

Wood technologists, glue experts, and veneer men have long endeavored to make a redwood plywood, and until the Harbor process was developed the demands of architects, decorators, and designers for laminated panels of redwood were unanswered. So now the trade generally has a plywood with all the beauty, charm, and romantic qualities of redwood, plus the strength, light weight, large sizes, and non-splitting qualities of cross banded construction. Panels as large as 5 ft. by 12 ft. are standard, and larger sizes are available on special order.

WOOD STRUCTURAL DESIGN

The National Lumber Manufacturers Association, Washington, D. C., has just published Supplement No. 5 of the Wood Structural Design Data Series on "Wood Trusses—Stress Coefficients, Length Coefficients and Angles."

Consisting of 48 pages, this pamphlet is ingeniously arranged to assist the designer, architect and engineer in determining with a minimum of effort the stresses, lengths and angles of slope of members of nine common types of pitched and flat trusses. For each type of truss the values have been computed for seven common height-to-span ratios and for four to twelve panels inclusive with top or bottom chord vertical loading.

General formulae are given for determining the values for other height-to-span ratios. Compression and tension members are clearly differentiated by both the weight of lines on the sketches and the signs before the values in the tables. Included in the publication are tables for converting inches and fractions of an inch to decimals of a foot, and for converting fractions of an inch to decimals of an inch.

The arrangement of the data shows conclusively the effects upon the stresses, lengths and angles of the truss

members resulting from variation in the height-to-span ratio, lengths of span, top of bottom chord loading, type of web system and number of panels.

In addition to "Wood Structural Design Data," a 296-page volume of technical data dealing with properties of wood and standard sizes, general formulae, beam and column load tables, there are now available five supplements. No. 1, a four-page pamphlet on "Working Stresses for Structural Lumber and Timber," contains tables which give allowable working stresses and design formulae for various grades and species of structural lumber.

"Bolted Wood Joints," the name of Supplement No. 2, is also four pages and embodies safe allowable working loads for bolts in wood joints and explanatory information of their application including spacing and end margins.

Supplement No. 3 is titled "Maximum Spans for Joists and Rafters." Sixteen pages in length, it describes spans for joists of various sizes and spacings for usual live loads per square foot.

"Wood Columns," or Supplement No. 4, contains 24 pages giving design formulae and tables of loads for solid columns and connector-joined spaced columns.

The series of design data is intended to provide engineers, architects and students with authentic technical information pertaining to structural design in wood.

SHINGLE STANDARDS REVISED

Announcement is made by the National Bureau of Standards of a conference held in Seattle March 31 for revision of the Commercial Standard for Wood Shingles.

The grading standards established in 1931 by the shingle industry in cooperation with the Bureau of Standards have been the guide for the manufacture and certification of No. 1 grade shingles since that time, and concentration on the production of better wood shingles has met with a very gratifying consumer acceptance.

Chief reason for revision of the standard is to extend the benefits of labeling and certification to No. 2 and No. 3 shingles under present grading practices.

These shingles have a very definite place in the construction field and with the growing tendency for the specification of grade marked materials as stimulated by the Federal Housing Administration and other agencies it is felt that the industry and the buying public alike will be benefited by the inclusion of all grades within the shingle standard.

"FLEXIBILITY" OF AIR CONDITIONING

Engineering reports of a series of tests made in the Chicago Tribune building from January 8 to February 10 were characterized by William B. Henderson, executive vice-president of the Air Conditioning Manufacturers' Association, as "one of the most convincing revelations of the utility of air conditioning ever recorded."

The Tribune structure includes its printing plant and complete newspaper layout, radio station WGN and a tower structure filled with offices, all of which have year-round air conditioning.

With equipment adjusted for various requirements based on the different needs of the Tribune's editorial business and mechanical staffs, the special space needs of the radio studios and the tastes of a wide variety of office tenants, the installation was declared by Mr. Henderson to be a striking demonstration of the "flexibility" of air conditioning.

The engineering report showed that the system, which has been operating since the summer of 1934, and, in the radio section, since it was opened October 1, 1935, is supplying air three to four times cleaner than the outside atmosphere, a ratio of moisture content best adapted for health, and temperature that the authorities report is "just right."

The air, incidentally, is changed three times as rapidly as ordinarily is considered necessary.

Four factors were observed in studying the installation and its effects on human comfort and efficiency, the engineers reported. These were air temperature, relative humidity, bacterial count and carbon dioxide content.

The first two factors, according to the engineers, should be considered together. Feelings of warmth and comfort depend not on temperature alone, but also on the moisture content or relative humidity of the air. Dry air, even though the temperature may be comparatively high, feels colder than moist air at a lower temperature.

Furthermore, dry air results in excessive evaporation of moisture from the skin surfaces of the body and respiratory tract. This humidification becomes one of the most important functions of the air conditioning system when one considers how little moisture cold air contains.

For example, one pound of air at zero Fahrenheit can hold a maximum of 5.5 grains of water vapor to attain 100 per cent relative humidity. If this same air finds its way indoors and, without the addition of moisture is heated to 70 degrees, then the relative humidity drops to 5 per cent, even though the absolute moisture content is unchanged.

For this reason all outside air introduced into the Tribune building is put through a water spray after heating. An average of about 20 grains of water per pound of air is added by this method to bring the relative humidity of air at from 72 to 75 degrees up to the ideal amount—about 30 per cent. This average was maintained in all parts of the Tribune where the tests were made.

The bacterial count is a measure of the dust content and general purity of the air. When because of filtration the dust content is low, the number of colonies of air borne bacteria is also low, the engineers explained. The colonies are counted after specially prepared

For Any
Automatic Heating
or
Air Conditioning
Problem

DELCO-FRIGIDAIRE Offers the Most Complete Line of Equipment—



Here is the

DELCO CONDITIONAIR
typical of the General
Motors value in the Delco-
Frigidaire line. Fired by
oil or gas, this famous
product furnishes com-
plete winter or year
'round air conditioning
at remarkably low cost.

Ask For **FREE** Specifications of the **Delco Conditionair** Or Other Heating and Air Conditioning Products

The Delco-Frigidaire line of equipment is built and backed by General Motors, providing quick and easy public acceptance.

Most important product to architects is the Delco Conditionair for oil or gas, offering years of really economical operation because of its quality construction. It automatically heats, humidifies, filters and circulates healthful air throughout the house. And it provides your clients with protection against early obsolescence—because provision can easily be made for adding low-cost summer air conditioning at any time in the future.

For radiator systems Delco-Frigidaire offers the efficient Oil or Gas Automatic Furnace utilizing the Im-Pak-Tor method of extracting heat from the hot gasses before they can escape.

The Delco Oil Burner, famous for its quality and

dependability, furnishes low cost automatic heat for years to come. And the new Delco Stoker features several new developments by General Motors.

Complete Line of Air Conditioning, too

Delco-Frigidaire air conditioning equipment ranges in size from small self-contained units for single rooms to equipment for efficiently air conditioning large buildings. Delco-Frigidaire has had a unique experience in this wide range of installations.

FREE HELP TO ARCHITECTS

Complete detailed specifications on all Delco-Frigidaire equipment are available upon request. No obligation of course. And feel free to call on Delco-Frigidaire at any time for aid in any plans calling for automatic heating or air conditioning.

ALADDIN HEATING CORP.

DELCO-FRIGIDAIRE DEALER

5107 Broadway

Oakland, California

Telephone OLYmpic 5424

JOHNSON SETS A STANDARD IN OIL BURNERS

with the new



"BANKHEAT" Pressure Type
Johnson Oil Burner

"BANKHEAT" PRESSURE TYPE

...compact, efficient... and built for years of service. Automatically shuts off when the required temperatures are reached. As burner stops, counterbalanced draft shutter closes, preventing passage of cold air through boiler, conserving fuel & lengthening life of furnace.

S. T. JOHNSON CO.

940 ARLINGTON, OAKLAND, CALIFORNIA
401 N. BROAD STREET, PHILADELPHIA, PA.

THERE'S A JOHNSON FUEL OIL BURNER FOR EVERY PURPOSE

"Goods of the Woods"

Dependable Building Materials

Lumber and Millwork
for
All Types of Construction

★

Wolmanized or Creosoted
Lumber and Timbers
is your protection against
Termites and Decay

★

E. K. WOOD LUMBER CO.

San Francisco

Los Angeles

Oakland

papers for catching dust are incubated for 48 hours at 98 degrees Fahrenheit.

Outdoors the average bacterial count in the standard measure of air is about 19 colonies. Inside the Tribune building the average bacterial colony count is 5.25. The report said: "The count obtained in the press room was surprisingly low at 4. The highest was obtained in studio A (WGN), where 14 colonies were found." The report explained this count had been taken early in the evening after the audience had arrived and a large amount of dust and lint had been brought in from outdoors.

Analysis of the carbon dioxide content of a room is a convenient means, the engineers say, of determining the extent to which outdoor air is being supplied. Outdoor air contains approximately four parts of carbon dioxide to 10,000 parts of air. An adequately ventilated room would show a high carbon dioxide content. A low content in an occupied room means that a liberal amount of fresh air finds its way inside.

Inside the Tribune building the average content was about 5 parts in 10,000. This is considered exceptionally good. Of one room on the north side of the 10th floor in the tower the report said:

"This room, with the lowest volume of air per occupant obtained in the tests, is receiving approximately three times the minimum volume considered necessary."

L. A. DRAFTSMEN ORGANIZE

Despite inclement weather more than fifty men interested in the formation of an association of architectural draftsmen attended a meeting March 1 in the Architects' Building, Los Angeles.

Aubrey Horn gave a short account of what had been done during the past month and of the number of meetings of the organization committee named by the State Association of California Architects, composed of Messrs. Horn, Balch, Eggers, Fields and Mussa. The constitution and by-laws of the Southern Section of the California Society of Architectural Draftsmen were read and after discussion were adopted as presented. In the discussion much interest was shown concerning the representation of the Society in the conventions of the State Association of California Architects; the extent of this representation, however, has not yet been established. The question of the use of funds for the purpose of publicity aroused considerable discussion.

There were twelve nominations for the six places on the executive board, and from these the following were elected: For two years, Henry Eggers, Bob Fields, and Aubrey Horn; for one year, Olive Shattuck, Glen Balch, and Mr. Rogers. The members of the executive board retired and chose officers as follows: President, Aubrey Horn; vice-president, Bob Fields; secretary, Olive Shattuck; treasurer, Henry Eggers. Dues to the amount of thirty dollars were collected and the meeting adjourned.

The Southern Section of the California Society for Architectural Draftsmen will have its headquarters in Los Angeles.

GOULD MAKES APPOINTMENTS

Appointment of four members of the Seattle area committee for the 52nd annual exhibition of the Architectural League of New York was recently announced by Carl F. Gould, Hoge Building, Seattle, chairman. Acceptances have been indicated by the appointees, as follows: Sculpture, Dudley Pratt, College of Fine Arts, U. of W.; painting, R. B. Inverarity, Washington state division, Federal Art project; landscape architecture, Fred A. Cuthbert; decorative arts and crafts, Mrs. Reginald Parsons.

GRANTED LICENSES TO PRACTICE

Licenses for the practice of architecture in Oregon were granted three Portland men as a result of examinations held recently. H. Abbott Lawrence, son of Ellis F. Lawrence, dean of the school of architecture, University of Oregon, Don Lee Dougan, son of L. L. Dougan, active Portland architect, and Elmer Zeller are the three. All are graduates of the University of Oregon.

WASHINGTON STATE COMPETITION

Lance E. Gowen, Textile Tower, Seattle, has been appointed special professional adviser for a state wide architectural competition for a Washington State building at the New York world's fair. Eric A. Johnston, Spokane, is commission chairman. E. B. McGovern, Seattle, is a member directly interested in the building project.

STRUCTURAL ENGINEERS MEET

Thirty engineering students of Bay Region universities and colleges, with their deans and professors, were guests April 5th at the meeting of the Structural Engineers' Association of Northern California.

The gathering was held at the Engineers' Club, 206 Sansome Street, San Francisco. Dinner preceded the business session.

LODI GRAMMAR SCHOOL

Victor J. Galbraith, architect of Stockton, has completed revised drawings for a one story U shaped frame and stucco school building for the Houston Grammar School District, estimated to cost \$50,000.

BOOK REVIEW

GARDEN BULBS IN COLOR: By McFarland, Hatton and Foley; Macmillan Company, Publishers, New York City, N. Y. Price: \$3.50.

This is one of the most beautiful garden books we have seen. It is easily predictable that gardeners will find here the book for which they have been waiting and hoping for many years. Two hundred and seventy-five pictures in color, together with reproductions from photographs, make this book a veritable gallery of flower pictures. The text is brief, but sufficient, and after all who wants very much text when there are so many entrancing pages of gorgeous color.

SPRINKLER EQUIPPED



Partial view of second floor **Rosenberg's Department Store** SANTA ROSA

(Note ceiling sprinkler heads)

The complete automatic sprinkler system in this modern building is a sure guarantee against destruction by fire. Similar installations may be leased by client and avoid investment of working capital; allowing insurance saving for amortization.

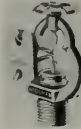

Installed by

Fire Protection Engineering Co.

C. T. CLIFFORD, President

369 Pine Street

San Francisco

M O D E R N

THANKS TO
STANLEY
"SWING-UP"
HARDWARE



You can design any garage door treatment and be sure it can be carried out, with the help of Stanley "Swing-Up" Hardware. The single flat surface is unbroken, is easily decorated. Size and shape are unrestricted, too.

FOR NEW OR
OLD DOORS

Stanley "Swing-Up" Hardware may be applied to any pair of stock doors, old or new, or a single door of any design. A slight pull "floats" the door up out of the way. Garage need be no longer than the car.

Write for full details. The Stanley Works, New Britain, Conn. Los Angeles: 407 American Bank Building; San Francisco: 576 Monadnock Building; Seattle: 568 First Avenue, South.

STANLEY

BUILD WELL~

A PROPERLY designed and well constructed building is a credit to any city and a profitable investment for its owner.

Such structures are the STANDARD OIL BUILDING, MATSON BUILDING, FOUR-FIFTY SUTTER STREET, STOCK EXCHANGE, S. F. BASE BALL PARK, MILLS TOWER, OPERA HOUSE and VETERANS' MEMORIAL, San Francisco, OLYMPIC CLUB ALTERATIONS, SANTA ANITA RACING PLANT and other notable structures — all built or supervised by —

Lindgren & Swinerton, Inc.

Standard Oil Building 605 W. Tenth Street
San Francisco Los Angeles
We Maintain a Termite Control Department

The better homes of today are
AIR CONDITIONED
for year-round weather

Consult us for the answer to your problems
MANUFACTURERS



OIL FIRED FURNACES
GAS FIRED FURNACES
SHEET METAL PRODUCTS

Harer-Perry Company

5662 Keith Ave., Oakland, Cal.
Phone HUmboldt 7928

A Permanent Exposition
of the newest ideas
in home planning
and equipment.



THE BUILDING MATERIAL EXHIBIT

Architects Bldg. • Fifth & Figueras • Los Angeles • MU-6306

INCLUDE TREES IN YOUR PLANS

DAVEY, ORIGINATOR OF TREE SURGERY, OFFERS FREE INSPECTION AND ESTIMATE.



SAN FRANCISCO Fresno LOS ANGELES
Russ Bldg., Mattei Bldg. Story Bldg.
SUTHER 3377 TUCKER 1929
Local phones in: Pasadena, Palo Alto,
Oakland, San Rafael, San Mateo

SKILL - KNOWLEDGE - RESPONSIBILITY

STRUCTURAL STEEL

For Class A Buildings,
Bridges, etc.

JUDSON PACIFIC CO.

609 MISSION STREET
SAN FRANCISCO

Plants: San Francisco - Oakland

USE BASALITE

Light-weight, pre-fabricated Concrete building products for floors, walls, and roofs in your next building.

BASALT ROCK COMPANY, INC.

Napa, California

NOISE Control

Office Quieting
Sound-proof Partitions
Acoustical Correction

WESTERN ASBESTOS CO.

Building Materials *Mechanical Specialties*
SACRAMENTO OAKLAND
SAN FRANCISCO

MULLEN MFG. COMPANY

BANK, STORE AND OFFICE
FIXTURES—CABINET WORK
OF GUARANTEED QUALITY
CHURCH SEATING

Office and Factory:
40-80 RAUSCH ST., Bet. 7th and 8th Sts.
San Francisco
Telephone UNderhill 5815

OVER NIGHT OR JUST A MEAL



SANTA MARIA INN

FRANK J. McCoy, Manager
On the Coast Highway, midway between
San Francisco and Los Angeles

SPECIFY

DUTCH BOY

Painter Products

BASS - HUETER

Paints and Varnishes

NATIONAL LEAD COMPANY

San Francisco Seattle
Portland Los Angeles

Branches and dealers in all principal cities

G. P. W. JENSEN & SON

Building Construction

320 Market Street, San Francisco
Phone: GARfield 2444

SOCIAL SECURITY PAYMENTS

A recent report of the Federal Social Security Board shows that 4,307 California wage earners or their families had received lump-sum settlements under the old-age insurance program of the social security act at the end of February. Total payments to these recipients amounted to \$128,800.

These settlements under the old-age insurance program should not be confused with payments made to needy aged persons under the public assistance provisions of the social security act. Federal old-age insurance covers wage earners employed in covered occupations and is pointed toward the providing of a monthly annuity at age 65 to workers who meet the requirements of the act.

The lump sum settlement is the answer to the question frequently raised by employees who ask "But suppose I don't live to be 65. What happens then?"

When a worker dies after being employed at an occupation covered by the old-age insurance plan, the Federal government makes a lump-sum settlement with his family or estate. This represents one of the two types of claims paid under this part of the social security act. The other type of claimant is the worker who attains age 65 this year and who also has been employed at some covered occupation since the plan became effective on January 1, 1937.

Within recent months the field managers of the social security board in California have initiated a campaign to familiarize employers with this feature of the old-age insurance system in order that the employer in turn might bring this information to the attention of his employees or to the families of employees who die.

Many California employers, it is reported, are now informing the nearest field office of the Social Security Board of persons who appear to be eligible claimants under the old-age insurance system.

The number of claimants and the average value of lump sum settlements have increased steadily since the old-age insurance program became effective. The reason for this

**HOTEL
L'AREMON**

20 Acres of Park

Enjoy...

... all the benefits of a country estate in town.

Tennis, riding, golf, dancing, quiet nights to insure sound sleep. Excellent meals at moderate family prices. Large outside rooms with bath \$2.00 and \$2.50. Ideal location overlooking Golden Gate, convenient to all Bay cities. Write today for descriptive booklet.

BERKELEY California

OFFICE FURNITURE
MODERATE PRICES
LIBERAL BUDGET TERMS

H. S. CROCKER COMPANY, Inc.

565 Market St. 260 Montgomery St.
SAN FRANCISCO

Robert W. Hunt Company ENGINEERS

Inspection - Tests - Consultation

Schools and Other Structures
Are Built as Designed

When Construction Materials are
Inspected at point of Manufacture
and during Erection by

ROBERT W. HUNT COMPANY

Cement, Concrete, Chemical, Metallurgical,
X-Ray and Physical Laboratories

Chicago - New York - Pittsburgh
Los Angeles - All Large Cities
San Francisco, 251 Kearny Street



No longer a problem
for the Architect

TRANSIT MIX CONCRETE AND MORTAR

makes delivery of material to the job swift and inexpensive . . . minimizing the architect's supervision costs and assuring his client a dependable mix.

Speed . . . Reliability . . . Economy
Let us co-operate with you

Golden Gate-Atlas Materials Co.

16th and Harrison Streets
San Francisco
UNderhill 3650

COMBINATION WATER FAUCET AND DRINKING FOUNTAIN FOR PUBLIC LAVATORIES



Model No. 2G

Here is a combination water faucet and drinking fountain, designed for lavatories in both public and private buildings. Not only a great convenience but saves cost of more expensive installations.

Have you our Catalog "R"

HAWS DRINKING FAUCET CO.
1808 Harman Street Berkeley

is that the settlement with both classes of claimants is computed at 3½ per cent of the wages earned at covered employments between January 1, 1937, when the system became effective, and the date of death or attainment of age 65. Not more than \$3000 in wages from any one employer in a calendar year is considered in computing the amount of a lump sum settlement.

In California, for example, total payments to the two types of claimants in January and February of this year exceeded payments made for the entire year 1937. The average settlement with California claimants increased from \$27.64 in December to \$38.18 in February. All valid claims received by field offices of the Social Security Board are prepared for submission to the Board in Washington regardless of the size of the claim.

A few examples of the amount of the settlement under varying rates of pay will illustrate the increasing importance of these payments. At the end of March, 1938, the old-age insurance program will have been in effect approximately 65 weeks (52 weeks in 1937 plus 13 weeks in the first quarter of 1938).

If the worker has been employed at covered work during these 65 weeks at a wage or salary of \$30 per week, his total earnings will aggregate \$1950. The lump sum settlement, based upon 3½ per cent of those earnings would be \$68.25. At a wage of \$40 per week during this time the total earnings would be \$2600 and the settlement—in case of death or the attainment of age 65 after these earnings had been made—would be \$91. These settlements, it will be observed, amount to slightly more than a half month of wages.

Those attaining 65 may receive the lump sum settlement from the Federal government without retiring from employment in a cover occupation.

The essential purpose of the old-age insurance system is to provide a monthly annuity at age 65 to persons who meet the following requirements: (1) They must have worked at a covered occupation in 5 different calendar years after December 31, 1936 and previous to attaining age 65; (2) they



Original ideas in modern lighting as well as beautiful interpretations of pure period Light-oliers are always available in a wide and interesting variety at Incandescent. Although finely finished and beautifully executed, these selections are priced for today's restricted budgets.

Booklet "The Charm of a Well Lighted Home" available upon request.

INCANDESCENT SUPPLY CO.

SAN FRANCISCO
OAKLAND
FRESNO
LOS ANGELES

SISALKRAFT

REG. U. S. PAT. OFF.

"More than a
building paper"

THE SISALKRAFT CO.

205 West Wacker Drive
(Canal Station) Chicago, Ill.
55 West Montgomery Street
San Francisco, Calif.

Pacific Manufacturing Company

High Class Interior Finish
Quality Millwork

454 Montgomery St. 6820 McKinley Ave.
San Francisco Los Angeles
GARfield 7755 THornwall 4196

1315 Seventh Street, Oakland
GLEncourt 7850

Here's the last word IN BATHROOM HEATING



The WESIX "49er"!

Every new home should have one.
List price, only\$21.50
For catalog sheet and specifications
write to
1018 Wesix Building
San Francisco, California

WESIX

ELECTRIC HEATER CO.

must have earned at least \$2000 in total wages after December 31, 1936 and previous to attaining age 65.

Monthly annuities will be based upon total wages earned in covered employments. Any employee desiring an estimate of the amount of the monthly annuity he will receive at age 65, based upon his present age and a prediction of his earnings up to that time, can obtain that information from any field office of the Social Security Board.

These field offices will supply the necessary forms to eligible claimants for a lump sum settlement and will also assist in preparing the forms for transmittal to the social security board in Washington. There is no charge to the claimant for this service. California employers and employees alike are invited to write to the nearest office of the Social Security Board for further information.

A list of Social Security Board offices in California, with the local address and name of the manager, follows:

Eureka, 205 Post Office Building, George A. Burkhead.

Fresno, 1221 Fulton Street, Arthur W. Louch.

Long Beach, 320 Pine Avenue, Victor C. Broome.

Los Angeles, 1121 South Hill Street, Charles H. Cunningham.

Oakland, 1440 Broadway, John A. Stellern.
Pasadena, 117 East Colorado Street, Charles E. C. Burnett.

Sacramento, 719 K Street, James G. Bretherton.

San Bernardino, Room 1, Court Building, John J. Cassidy.

San Diego, 306 Security Bank Building, James J. Norris.

San Francisco, 402 Humboldt Bank Building, James B. Cress.

Santa Barbara, 216 Post Office Building, Marion C. Mohen, (Acting Manager).

ABBOT A. HANKS, INC. Engineers & Chemists

INSPECTING — TESTING — CONSULTING
CONCRETE • STEEL • MATERIALS
CHEMICAL AND TESTING
LABORATORIES
• RESEARCH AND INVESTIGATION •

TESTS OF STRUCTURAL MATERIALS
DESIGN OF CONCRETE MIXES
SHOP AND ERECTION INSPECTION OF
STRUCTURES AND EQUIPMENT
INVESTIGATION OF STRUCTURES
AND MATERIALS
TESTS AND INVESTIGATION OF
FOUNDATION SOILS
FIRE RESISTANCE AND INSULATION
TESTS

624 Sacramento Street, San Francisco

VAUGHN - G. E. WITT Co.

Manufacturers and Distributors

Pump Governors	Oil Heaters
Safety Pump Governors	Relief Valves
Automatic Gas Regulating Valves	Oil Burner Governors
Gas Burning Equipment	Oil Burners
Vacuum Pump Governors	Oil Pumping Sets
Vacuum Regulating Valves	Oil Valves
Continuous Flow Steam Traps	Oil and Steam Strainers
Thermostats	Duplex Oil Pumps
Reducing Valves	Rotary Oil Pumps
	Boiler Feed Pumps
	Water Heaters
	Boiler Feed-Water Regulators

4224-28 Hollis St., Emeryville, Oakland



HERRICK IRON WORKS

STRUCTURAL STEEL

18TH AND CAMPBELL STS.
OAKLAND, CALIF.

Phone GLEncourt 1767

FORDERER Cornice Works

Manufacturers of

Hollow Metal Products
Interior Metal Trim
Elevator Fronts and Cabs
Metal Wall Plugs, Anchors, Etc.
Sheet Metal Products
Sanitary Metal Base
Commercial Refrigerators
Building Paper
Metal and Wire Accessories
for Concrete

269 POTRERO AVENUE
San Francisco, Calif.

HEmlock 4100
CONSULT OUR ENGINEERING
DEPARTMENT

BUSINESS TREND SURVEY

Based on records covering more than 10 per cent of the dollar volume of American business, the preliminary report of the Survey of Business Trends in the March issue of Dun's Review states: "Manufacturing sales of \$45.8 billions in 1935 increased 20 per cent to \$55.1 billions in 1936 and 13 per cent to \$62.4 billions in 1937. Retailing advanced from the 1935 level of \$33.2 billions to \$38.3 in 1936 and \$41.4 billions in 1937. Despite the

PAN-AMERICAN (Simplex)



Model 12

AUTOMATIC OIL BURNER

The model illustrated is the smallest of many sizes and types of oil burners built by

PAN-AMERICAN ENGINEERING CO.

820 Parker Street • Berkeley
Phone BErkeley 6755

ECONOMY OF SUB-STRUCTURE

That has to be
considered on
every job.

FERRO - PORCELAIN
needs but a
frame to hold it,
and it is
'quake' proof.

Inquiries promptly answered

FERRO ENAMELING CO.

1100 - 57th Ave., Oakland, Calif.

disastrous final quarter in 1937, the total sales for the year in all major divisions of business except construction were appreciably larger than in 1936, but the rate of increase was not as sharp as the gain in 1936 over 1935."

With respect to inventories, the total estimate for manufacturing, wholesaling and retailing at the end of 1935 is placed at \$16.6 billions. By the end of 1937, this total had increased to \$21.7 billions with a somewhat greater advance in the second year than the first. The Survey points out that the manufacturing industries, which account for about 60 per cent of the total, not only recorded the largest dollar increases but the greatest per cent increases of inventory in each year.

Estimates also presented for accounts receivable show an increase in all lines during 1936, but indicate reductions during 1937 for manufacturing and wholesaling, contrasted with an increase of 8 per cent in retailers' accounts outstanding.

Pitcher

**Improved
Disappearing Doors
Save 20% Space**

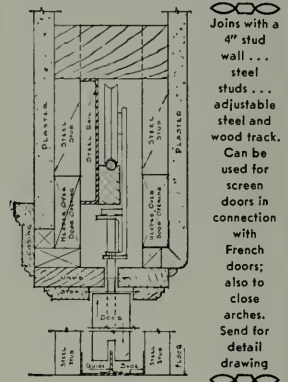

E. C. Pitcher Co.

461 Market Street
San Francisco

Independent Iron Works

Structural Steel
Ornamental Iron
Steel Service Stations
Steel Tanks
Standard Steel Mill Buildings
Bridges

821 Pine Street Oakland

ROLL-AWAY

OF BERKELEY

WINDOW SCREENS

HAVE NO
EQUAL

A specification leaving no opportunity for substitution . . . will be permanently appreciated by every client.

ROLL-AWAY WINDOW
SCREEN COMPANY
8TH & CARLTON STS., BERKELEY, CALIF.
SAN FRANCISCO 557 MARKET ST.
LOS ANGELES 169 N. LA BREA

ANDERSON & RINGROSE

General Contractors

320 Market Street, San Francisco
Phone GARfield 2245

Clinton Construction Co.

of California

General
Contractors

923 Folsom Street
San Francisco
SUtter 3440

HIGH GRADE MILLWORK
AND INTERIOR FINISH
SASH AND DOORS

LANNOM BROS. MFG. CO.

FIFTH AND MAGNOLIA STREETS
OAKLAND, CALIFORNIA
Telephone: LAkeside 3663

Phone GARfield 1164

Hunter & Hudson

Consulting Engineers

DESIGNERS OF HEATING
AIR CONDITIONING
VENTILATING AND WIRING
SYSTEMS, MECHANICAL
AND ELECTRICAL EQUIP-
MENT OF BUILDINGS

41 SUTTER STREET
ROOM 710

San Francisco California

Whether large or small
Stucco Buildings
are Best Protected
with

CEMENTEX DUNNE'S

Coating for Stucco
The Hayward High School
is
one example

FRANK W. DUNNE CO.

41st and Linden Sts. Oakland, Calif.
MAKERS OF GOOD PAINT

COMFORT

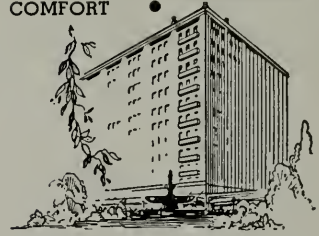

New

HOTEL CLARK

in Downtown

LOS ANGELES

Convenience is another offering of this hotel. Whether on business or pleasure bent, the Hotel Clark makes an ideal "base of operations," as well as a restful "billet" at the end of the day's "campaign." Good Food, naturally. And moderate charges, as well as for room accommodations, give final significance to assuring word — COMFORT

Single from \$2.50
Double from \$3.50

ROOMS
5 5 5
BATHS

Fifth and Hill

P. C. B. MORRIS, Manager

"AMERICAN MARSH" Redi-Vac Vacuum Heating Pump

Send for
Bulletin 441

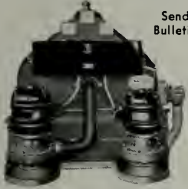

SIMONDS MACHINERY CO.
San Francisco Los Angeles
816 FOLSOM ST. 522 EAST 4TH ST.

REPUBLIC STEEL CORPORATION



Manufacturers of

ENDURO Stainless Steel; TON-
CAN Copper Molybdenum Iron
Sheets and Pipe; and Steel Pipe,
Sheets and Reinforcing Bar for
every building purpose.

Write for information

Rialto Building, San Francisco, Calif.
Edison Building, Los Angeles, Calif.
White-Henry-Stuart Bldg., Seattle, Wash.

DINWIDDIE CONSTRUCTION COMPANY

●
BUILDERS OF
GOOD BUILDINGS

●
CROCKER BUILDING
SAN FRANCISCO

JOHN CASSARETTO

—Since 1886—And Still Active—

Building Materials

READY MIX CONCRETE
ROCK - SAND - GRAVEL - LIME
CEMENT - PLASTER - MORTAR
METAL LATH - WOOD LATH
STUCCO - WIRE NETTING

Service Unexcelled

Bunkers
Sixth and Channel, San Francisco
Phones: GARfield 3176, GARfield 3177

Smith

Lumber Company

WHOLESALE - JOBBING - RETAIL

FACTORY AND BUILDING LUMBER
PLYWOODS - ROOFING

DISTRIBUTING YARDS

San Francisco

Oakland

4th & Channel

19th Ave. &

Estuary

Market 0103

FRuitvale 3174

YOUR INQUIRIES SOLICITED

Carl T. Doell Co.

*Plumbing
Heating*

Plumbing Contractor
Veterans Memorial Building
Oakland

467 21ST STREET
OAKLAND

Telephone GLencourt 8246

THE TORMEY COMPANY

GENERAL PAINTERS
AND DECORATORS

—
Phone UNDERhill 1913

563 FULTON STREET
San Francisco

JOSEPH MUSTO SONS-KEENAN COMPANY

MARBLE

and

ONYX

535 NORTH POINT STREET
SAN FRANCISCO
1801 S. SOTO STREET
LOS ANGELES

MOORE & ROBERTS

Builders of
ROSENBERG'S DEPARTMENT STORE
Santa Rosa, Calif.

•
693 Mission Street San Francisco
Phone GARfield 8546

Firms on This Page
Contributed to the Successful
Construction of
Rosenberg's Department Store,
Santa Rosa
and the
Sky Room, Hotel Empire,
San Francisco

THE HANDSOME BAR
in the
Skyroom of the Empire Hotel
San Francisco
by

WM. BATEMAN

CONTRACTOR
1915 Bryant Street San Francisco

James A. Nelson, Inc.

Heating, Ventilating and Plumbing
Contractors

FOR
ROSENBERG'S DEPARTMENT STORE

•
1375 HOWARD STREET
Cor. Tenth
San Francisco

G. A. Meyer, President

American Electric Construction Co.

(Incorporated)

ELECTRICAL CONTRACTORS

Telephone EXbrook 6689

•
426 Bryant St. San Francisco, Calif.

SKY ROOM

HOTEL EMPIRE

Stainless steel bar interior,
cocktail racks, sinks, drain-
boards, bottle chests and
metal trim

Manufactured and installed by

BARTHOLD

SODA FOUNTAIN CO., LTD.
910 HOWARD STREET SAN FRANCISCO
Phone EXbrook 5351

PRESTON P. HOPKINS

ILLUMINATION
DESIGNER

210 POST STREET SAN FRANCISCO

"MOULTILE"

REINFORCED
ASPHALT TILE

Installed in all ground floor
areas in
Rosenberg's Main Store
and Shops

The answer to problems of
floor coverings for con-
crete on or below ground.



Encaustic floor and wall
tile installed in lavator-
ies, Hotel Empire Sky
Room, San Francisco.



American Art Tile Co.

231 FRANKLIN STREET
SAN FRANCISCO

Sky Room, Hotel Empire
San Francisco

AIR CONDITIONED

— by —

Cochran & St. John, Ltd.

952 Mission Street
San Francisco



MERCURY PRESS

We Print
The ARCHITECT and
ENGINEER

*"A Thing of Beauty
Is a Joy Forever"*

942 HOWARD STREET
SAN FRANCISCO

Copper Halftones
in this issue

Made by

Continental Engraving & Color Plate Co.

156 Second Street
San Francisco

ARCHITECTS' AND ENGINEERS' SPECIFICATION INDEX

Classified Directory of Building Material Manufacturers, Dealers and Contractors

*Denotes subscriber of ARCHITECTS' REPORTS, sponsored and endorsed by State Association of California Architects, and published daily by THE ARCHITECT AND ENGINEER.

ACOUSTICAL AND SOUND CONTROL
ARMSTRONG CORK PRODUCTS Co., 1355 Market Street, San Francisco.

*JOHNS-MANVILLE Sales Corp., 116 New Montgomery Street, San Francisco.

WESTERN ASBESTOS Co., 675 Townsend Street, San Francisco.

CRAMER Co., 50 Howard Street, San Francisco.

TURNER RESILIENT FLOORS, Inc., 141 New Montgomery Street, San Francisco.

CELOTEX Corp., 675 Townsend Street, San Francisco.

AIR CONDITIONING

S. T. JOHNSON Company, 940 Arlington, Oakland.

*ELECTRIC APPLIANCES, Inc., 2001 Van Ness Avenue, San Francisco.

*ALADDIN HEATING Corporation, 5107 Broadway, Oakland.

*FRANK EDWARDS Co. (General Electric), 930 Van Ness Avenue, San Francisco.

GENERAL Air Conditioning & Heating Company, 4001 Piedmont Avenue, Oakland.

ARCHITECTURAL METAL SUPPLIES

*BRAUN-STEEPLE Co., 636 Potrero Ave., San Francisco.

ARCHITECTURAL TERRA COTTA

N. CLARK & SONS, 116 Natoma Street, San Francisco.

GLADDING McBEAN & Co., 9th and Harrison Streets, San Francisco; 2901 Los Feliz Boulevard, Los Angeles; 1500 First Avenue South, Seattle; 79 S. E. Taylor Street, Portland; 22nd and Market Streets, Oakland; 1101 N. Monroe Street, Spokane; Vancouver, B.C.

KRAFTILE COMPANY, Niles, California, and 525 Market Street, San Francisco.

BATHROOM HEATERS

WESIX ELECTRIC Heater Company, 390 First Street, San Francisco; 631 San Julian Street, Los Angeles; 2008 Third Avenue, Seattle, Wash.

BLINDS—VENETIAN

GUNN-CARLE & Co., 20 Potrero Avenue, San Francisco.

*H. E. ROOT, 1865 California Street, San Francisco.

*RY-LOCK Co., 1355 Market Street, San Francisco.

BOILERS AND PIPE

*C. C. MOORE & Company, 450 Mission Street, San Francisco.

BRICK—FACE, COMMON, ETC.

N. CLARK & SONS, 116 Natoma Street, San Francisco.

GLADDING McBEAN & Co., 9th and Harrison Streets, San Francisco; 2901 Los Feliz Boulevard, Los Angeles; 1500 First Avenue, South, Seattle; 79 S. E. Taylor Street, Portland; 22nd and Market Streets, Oakland; 1102 N. Monroe Street, Spokane; Vancouver, B.C.

BRASS

AMERICAN BRASS Co., Russ Building, San Francisco.

BUILDERS HARDWARE

THE STANLEY WORKS, New Britain, Conn.; Monadnock Bldg., San Francisco; Los Angeles and Seattle.

*SCHLAGE LOCK Co., 20 Blanken Avenue, San Francisco.

*FARMER'S UNION, 151 W. Santa Clara Street, San Jose.

*MAXWELL HARDWARE Company, 1320 Washington Street, Oakland.

*P. and F. CORBIN, New Britain, Conn.

BUILDING MATERIALS

BUILDING MATERIAL EXHIBIT, Architect's Building, Los Angeles.

*CONTRA COSTA BUILDING MATERIALS Company, 2824 Shattuck Ave., Berkeley.

*MISSION BUILDING MATERIALS Co., Millbrae, Calif.

*RHODES & KENNEDY, 101 4th Street, Oakland.

BUILDING PAPERS

THE SISALKRAFT Company, 205 W. Wacker Drive, Chicago, Ill., and 55 New Montgomery Street, San Francisco.

BUILDING PRODUCTS

"BASALITE," a lightweight, pre-fabricated material for floors, walls and roofs—Basalt Rock Co., Inc., Napa, California.

CABINET WORK

*FINK and SCHINDLER, 552 Brannan Street, San Francisco.

MULLEN MANUFACTURING Co., 64 Rausch Street, San Francisco.

*MODERN FIXTURE & Cabinet Co., 59 Oak Grove Street, San Francisco.

CEMENT

*CALAVERAS CEMENT Company, 315 Montgomery Street, San Francisco.

PORTLAND CEMENT Association 564 Market Street, San Francisco; 816 West Fifth Street, Los Angeles; 146 West Fifth Street, Portland; 518 Exchange Building, Seattle.

"GOLDEN GATE" and "OLD MISSION" manufactured by Pacific Portland Cement Co., 111 Sutter Street, San Francisco; Portland, Los Angeles and San Diego.

*HENRY COWELL Lime & Cement Company, 2 Market Street, San Francisco.

*SANTA CRUZ PORTLAND Cement Company, Crocker Building, San Francisco.

CEMENT—COLOR

"GOLDEN GATE TAN CEMENT" manufactured by Pacific Portland Cement Co., 111 Sutter Street, San Francisco; Portland, Los Angeles and San Diego.

CEMENT PAINT

FRANK W. DUNNE Company, 41st and Linden Streets, Oakland.

CHEMICAL ENGINEERS

ABBOT A. HANKS, Inc., 624 Sacramento Street, San Francisco.

ROBERT W. HUNT, 251 Kearny Street, San Francisco.

CLAY PRODUCTS

GLADDING McBEAN & Company, San Francisco, Los Angeles, Portland and Seattle.

N. CLARK & SON, San Francisco and Los Angeles.

KRAFTILE Company, Niles, California, and 525 Market St., San Francisco.

*GLADDING BROS. Mfg. Co., San Jose.

CLOCKS—ELECTRIC TIME

*INTERNATIONAL BUSINESS Machines Corp., 25 Battery Street, San Francisco.

CONCRETE AGGREGATES

GOLDEN GATE ATLAS Material Company, Sixteenth and Harrison Streets, San Francisco.

JOHN CASSARETTO, Sixth and Channel Streets, San Francisco.

*TRANSIT CONCRETE, Inc., 2500 Peralta Street, Oakland.

CONCRETE CURING & PROTECTION

THE SISALKRAFT Company, 205 W. Wacker Drive, Chicago, Ill., and 55 New Montgomery Street, San Francisco.

CONTRACTORS—GENERAL

LINDGREN & SWINERTON, Inc., Standard Oil Building, San Francisco.

DINWIDDIE CONSTRUCTION Co., Crocker Building, San Francisco.

CLINTON CONSTRUCTION Company, 923 Folsom Street, San Francisco.

ANDERSON & RINGROSE, 320 Market Street, San Francisco.

G. P. W. JENSEN, 320 Market Street, San Francisco.

*GEO. ARTHUR & SON, 941 So. Claremont Street, San Mateo.

*A. T. BECKETT, 224 Scenic Avenue, Piedmont.

*L. M. G. PETERSON, 520 Bowdoin Street, Palo Alto.

*BARRETT & HILP, 918 Harrison Street, San Francisco.

DAMP-PROOFING & WATERPROOFING

"GOLDEN GATE TAN PLASTIC Waterproof Cement," manufactured by Pacific Portland Cement Co., 111 Sutter Street, San Francisco; Portland, Los Angeles and San Diego.

DOOR HANGERS

PITCHER'S SLIDING DOOR HANGERS, Sheldon Building, San Francisco.

DOORS—HOLLOW METAL

FORDERER CORNICE Works, Potrero Avenue, San Francisco.

KAWNEER Mfg. Co., Eighth Street and Dwight Way, Berkeley.

ACID PROOF DRAIN PIPE

CORROSION—Acid resisting pipe, fittings exhaust fans, pumps, etc., Pacific Foundry Co., 3100 19th Street, San Francisco; 1400 S. Alameda Street, Los Angeles.

DRINKING FOUNTAINS

HAWS DRINKING FAUCET Co., 1808 Harmon Street, Berkeley; American Seating Co., San Francisco, Los Angeles and Phoenix.

ELECTRIC ADVICE

PACIFIC COAST ELECTRICAL Bureau, 447 Sutter Street, San Francisco, and 601 W Fifth Street, Los Angeles.

ELECTRIC FIXTURES

*THE FRINK Corporation, 557 Market Street, San Francisco.

ELECTRICAL CONTRACTORS

*ALTA ELECTRIC and Mechanical Company 467 O'Farrell Street, San Francisco

*ELECTRICAL EQUIPMENT—SUPPLIES

*TRUMBULL ELECTRIC Mfg. Co., 260 Van Ness Avenue, San Francisco.

*GENERAL ELECTRIC Supply Corp., 1201 Bryant Street, San Francisco.

*NATIONAL ELECTRIC Products Co., 400 Potrero Avenue, San Francisco.

*WESTINGHOUSE ELECTRIC & Mfg. Co., 1 Montgomery Street, San Francisco.

ELEVATORS

*WESTINGHOUSE ELECTRIC Elevator Company, 1 Montgomery Street, San Francisco.

*OTIS ELEVATOR Company, Beach Street, San Francisco.

ENAMELING—PORCELAIN

FERRO ENAMELING Company, 1100 57th Street, Oakland.

FLOORING

ASPHALT TILE, Western Asbestos Company, 675 Townsend Street, San Francisco.

*L. S. CASE, Inc., 7th and Daggett Streets, San Francisco.

*JOHNS-MANVILLE Sales Corp., 116 New Montgomery Street, San Francisco.

MAPLE FLOORING MANUFACTURERS ASSOCIATION, McCormick Building, Chicago. Ask your lumber dealer.

LE ROY OLSON COMPANY, 3070 - 17th Street, San Francisco.

*LILLY & CROWLEY, 123 Kansas Street, San Francisco.

*FIXTURES—BANK, OFFICE, STORE MULLEN MANUFACTURING Co., 64 Rausch Street, San Francisco.

PACIFIC MANUFACTURING Company, 454 Montgomery Street, San Francisco, 1315 Seventh Street, Oakland, Los Angeles and Santa Clara.

ARCHITECTS' AND ENGINEERS' SPECIFICATION INDEX

Classified Directory of Building Material Manufacturers, Dealers and Contractors

*Denotes subscriber of ARCHITECTS' REPORTS, sponsored and endorsed by State Association of California Architects, and published daily by THE ARCHITECT AND ENGINEER.

FURNITURE

*ALLIED ART GUILD, Menlo Park.
*PENN. FURNITURE Shops, Inc., 130 Second Avenue, San Mateo.

GAS BURNERS

VAUGHN-G. E. WITT Company, 4224-26 Hollis Street, Emeryville, Oakland.

GLASS

W. P. FULLER & Co., 301 Mission Street, San Francisco. Branches and dealers throughout the West.

LIBBEY-OWENS-FORD GLASS Co., Toledo, Ohio; 633 Rialto Building, San Francisco; 1212 Architect's Building, Los Angeles; 550 Skinner Building, Seattle.

PITTSBURGH PLATE GLASS Company, Grant Building, Pittsburgh, Pa. W. P. Fuller & Co., Pacific Coast Distributors.

*L. H. BUTCHER COMPANY, Fifteenth and Vermont Sts., San Francisco.

*EAST VAY GLASS Company, 621 Sixth Street, Oakland.

*COBBLEDRICK-KIBBE GLASS Company, San Francisco and Oakland.

HEATING—ELECTRIC

WESIX ELECTRIC Heater Company, 390 First Street, San Francisco; 631 San Julian Street, Los Angeles; 2008 Third Avenue, Seattle, Wash.

HEATING—GAS

PACIFIC GAS & ELECTRIC Co., 245 Market Street, San Francisco.

GENERAL Air-Conditioning & Heating Company, 4001 Piedmont Avenue, Oakland.

HARER-PERRY Co., 5662 Keith Avenue, Oakland.

*W. H. PICARD, Inc., 4166 Broadway, Oakland.

*ALADDIN HEATING Corp., 5107 Broadway, Oakland.

HEATING—OIL

S. T. JOHNSON Company, 940 Arlington, Oakland.

HEAT GENERATORS

*WATROE CORPORATION, LTD., 1170 Howard Street, San Francisco.

HEATING & VENTILATING EQUIPMENT

*AMERICAN RADIATOR Company, 4th and Townsend Streets, San Francisco.

HEAT REGULATION

JOHNSON SERVICE Company, Milwaukee, represented on the Pacific Coast by the following branch offices: 814 Rialto Bldg., San Francisco; 153 West Avenue, 34, Los Angeles; 1312 N.W. Raleigh Street, Portland; and 473 Coleman Bldg., Seattle.

HOLLOW BUILDING TILE (Burned Clay)

N. CLARK & SONS, 116 Natoma Street, San Francisco.

GLADDING McBEAN & Co., 9th and Harrison Streets, San Francisco; 2901 Los Feliz Boulevard, Los Angeles; 1500 First Avenue South, Seattle; 79 S.E. Taylor Street, Portland; 22nd and Market Street, Oakland; 1102 N. Monroe Street, Spokane; Vancouver, B.C.

KRAFTILE Company, Niles, California, and 525 Market Street, San Francisco.

HOTEL AND RESTAURANT EQUIPMENT

*DOHRMANN HOTEL SUPPLY Company, 973 Mission Street, San Francisco.

INSPECTION AND TESTS

ABBOT A. HANKS, Inc., 624 Sacramento Street, San Francisco.

ROBERT W. HUNT Co., 251 Kearny Street, San Francisco.

INSULATION

CELOTEX Corp., 675 Townsend Street, San Francisco.

*JOHNS-MANVILLE Sales Corp., 116 New Montgomery Street, San Francisco.

WESTERN ASBESTOS Co., 675 Townsend Street, San Francisco.

CABOT'S QUILT—Gunn, Carle & Co., 20 Potrero Avenue, San Francisco.

VAPORSEAL, Mfg. by Celotex Corp., 919 N. Michigan Avenue, Chicago.

FIRTEX of Northern California, 461 Market Street, San Francisco.

*GEORGE D. KARSCH, Builders Exchange, Sacramento, California.

INSURANCE

*FIREMAN'S FUND Insurance Company, 401 California Street, San Francisco.

INTERIOR DECORATORS

*REED DRAPERY SERVICE, 440 Post Street, San Francisco.

*M. H. WALES, 1933 Laguna Street, San Francisco.

KITCHEN EQUIPMENT

*MANGRUM, HOLBROOK & ELKUS, 301 Golden Gate Avenue, San Francisco.

LACQUERS

W. P. FULLER & Co., 301 Mission Street, San Francisco. Branches and dealers throughout the West.

LIGHTING FIXTURES

*W. W. WARREN Company, 955 Mission Street, San Francisco.

*INCANDESCENT SUPPLY Company, 726 Mission Street, San Francisco.

*PHOENIX-DAY Company, 729 Mission Street, San Francisco.

LIMESTONE

*INDIANA LIMESTONE Company, 130 Lundo Way, San Francisco.

LINOLEUM, CARPETS, Etc.

*WEST COAST LINOLEUM & CARPET Co., 1163 Market Street.

*VAN FLEET-FREEAR Company, 557 Howard Street, San Francisco.

TURNER RESILIENT FLOORS, Inc., 141 New Montgomery Street, San Francisco.

*D. N. & E. WALTER & Company, 567 Mission Street, San Francisco.

*CONGOLEUM-NAIRN, Inc., 180 New Montgomery Street, San Francisco.

*K. M. BURCK, 505 B Street, San Mateo.

LOCKERS—METAL

*TRASK & SQUIER, 39 Natoma Street, San Francisco.

LUMBER

PACIFIC MFG. Co., 454 Montgomery Street, San Francisco; 1315 Seventh Street, Oakland; Los Angeles and Santa Clara.

SMITH LUMBER Company, Nineteenth Avenue and Estuary, Oakland.

MELROSE LUMBER & SUPPLY Co., Forty-sixth Avenue and E. Twelfth Street, Oakland.

E. K. WOOD LUMBER Company, 4701 Santa Fe Avenue, Los Angeles; 1 Drumm Street, San Francisco; Frederick and King Streets, Oakland.

*SANTA FE LUMBER Company, 16 California Street, San Francisco.

FRIEND & TERRY LUMBER Co., Front & S Streets, Sacramento.

*OAKLAND LUMBER Co., 6901 E. 14th Street, Oakland.

MACHINERY—PUMPS, Etc.

SIMONDS MACHINERY Company, 816 Folsom Street, San Francisco.

MARBLE

JOSEPH MUSTO SONS-KEENAN Co., 535 N. Point Street, San Francisco.

MILLWORK

E. K. WOOD LUMBER Company, No. 1 Drumm Street, San Francisco, Oakland, Los Angeles.

LANNOM BROS. Mfg. Co., Fifth and Magnolia Streets, Oakland.

MELROSE LUMBER & SUPPLY Company, Forty-sixth Avenue and E. Twelfth Street, Oakland.

PACIFIC MFG. Co., 454 Montgomery Street, San Francisco; 1315 Seventh Street, Oakland; Los Angeles and Santa Clara.

SMITH LUMBER Company, Nineteenth Avenue and Estuary, Oakland.

*WESTERN DOOR and SASH Company, 5th and Cypress Streets, Oakland.

*OAKLAND PLANING MILL, 105 Washington Street, Oakland.

*T. P. HOGAN Company, 2d and Alice Streets, Oakland; 630 Mission Street, San Francisco.

*SAN MATEO PLANING MILL, San Mateo.

MONEL METAL

"INCO" BRAND, distributed on the Pacific Coast by the Pacific Metals Company, 3100-19th Street, San Francisco, and 1400 So. Alameda Street, Los Angeles.

*WHITEHEAD METAL APPLIANCE CO., 4238 Broadway, Oakland.

NURSERY STOCK

*C. J. BURR, 305 Lytton Avenue, Palo Alto.

*CALIFORNIA NURSERIES, Niles.

OIL BURNERS

*SAN MATEO FEED and FUEL Company, San Mateo, Cal.

S. T. JOHNSON Co., 585 Potrero Avenue, San Francisco; 940 Arlington Street, Oakland; 1729 Front Street, Sacramento, and 1020 El Camino Real, San Carlos, Calif.

VAUGHN-G. E. WITT Co., 4224-28 Hollis Street, Emeryville, Oakland.

*HORABIN OIL & BURNER Company, 234 Hamilton Avenue, Palo Alto.

PAN-AMERICAN SIMPLEX OIL BURNER, 820 Parker Street, Berkeley.

ONYX

JOSEPH MUSTO SONS-KEENAN Co., 535 No. Point Street, San Francisco.

ORNAMENTAL IRON

INDEPENDENT IRON WORKS, 821 Pine Street, Oakland.

PAINTING, DECORATING, Etc.

THE TORMEY Co., 563 Fulton Street, San Francisco.

*RAPHAEL Company, 270 Tehama Street, San Francisco.

PAINTS, OIL LEAD

W. P. FULLER & CO., 301 Mission Street, San Francisco. Branches and dealers throughout the West.

FRANK W. DUNNE Co., 41st and Linden Streets, Oakland.

NATIONAL LEAD Company, 2240-24th Street, San Francisco. Branch dealers in principal Coast cities.

*SHERWIN-WILLIAMS Company, 1415 Sherwin Avenue, Oakland.

PARTITIONS—MOVABLE OFFICE

PACIFIC MFG. Co., 454 Montgomery Street, San Francisco; 1315 Seventh Street, Oakland; factory at Santa Clara.

PLASTER

"EMPIRE" and "RENO HARDWARE PLASTER," manufactured by Pacific Portland Cement Co., 111 Sutter Street, San Francisco; Portland, Los Angeles and San Diego.

ARCHITECTS' AND ENGINEERS' SPECIFICATION INDEX

Classified Directory of Building Material Manufacturers, Dealers and Contractors

*Denotes subscriber of ARCHITECTS' REPORTS, sponsored and endorsed by State Association of California Architects, and published daily by THE ARCHITECT AND ENGINEER.

PLASTERING CONTRACTOR

*JAMES F. SMITH, 271 Minna Street, San Francisco.

PLASTER—ACOUSTICAL

CALACOUSTIC, Sound Absorbing Plaster, manufactured by Pacific Portland Cement Co., 111 Sutter Street, San Francisco, Los Angeles and San Diego.

PLASTER MATERIALS

*U. S. GYPSUM Company, Architect's Building, Los Angeles.

PLATE GLASS

LIBBEY-OWENS-FORD GLASS Co., Toledo, Ohio; 633 Rialto Building, San Francisco; 1212 Architect's Building, Los Angeles; Mr. C. W. Holland, P.O. Box 3142, Seattle.

PLUMBING CONTRACTORS

CARL T. DOELL, 467-21st Street, Oakland.

*SCOTT Company, 243 Minna Street, San Francisco.

*W. H. PICARD, 4166 Broadway, Oakland.

PLUMBING FIXTURES AND SUPPLIES

CRANE Co., all principal Coast cities.

*STANDARD SANITARY Manufacturing Company, 278 Post Street, San Francisco.

*WALWORTH CALIFORNIA Company, 665 Sixth Street, San Francisco.

*W. R. AMES Co., 150 Hooper Street, San Francisco.

PRESSURE REGULATORS

VAUGHN-G, E. WITT Co., 4224-28 Hollis Street, Emeryville, Oakland.

PUMPS

SIMONDS MACHINERY Company, 816 Folsom Street, San Francisco.

REFRIGERATION

FRIGIDAIRE ELECTRIC REFRIGERATORS, Aladdin Heating Corp., 5107 Broadway, Oakland.

ROOFING CONTRACTORS

*MALLOTT & PETERSON, 2412 Harrison Street, San Francisco.

*MARSHALL SHINGLE Company, 608-16th Street, Oakland.

ROOFING INSULATION

*JOHNS-MANVILLE Sales Corp., 116 New Montgomery Street, San Francisco.

ROOF MATERIALS

*JOHNS-MANVILLE Sales Corp., 116 New Montgomery Street, San Francisco.

*PIONEER FLINTKOTE Company, Shell Building, San Francisco.

*PARAFFINE Company, Inc., 475 Brannan Street, San Francisco.

GLADDING McBEAN & Co., 9th and Harrison Streets, San Francisco; 2901 Los Feliz Boulevard, Los Angeles; 1500 First Avenue South, Seattle; 79 S.E. Taylor Street, Portland; 22nd and Market Street, Oakland; 1102 N. Monroe Street, Spokane-Vancouver, B.C.

N. CLARK & SONS, 112-116 Natoma Street San Francisco; works, West Alameda.

*CERTAIN-TEED PRODUCTS Co., 315 Montgomery Street, San Francisco.

SAFES

HERRING-HALL-MARVIN SAFE Co., 214 California Street, San Francisco.

SAND, ROCK AND GRAVEL

JOHN CASSARETTO, Sixth and Channel Streets, San Francisco.

BASALT ROCK Co., Nepa.

*KAISER PAVING Company, Latham Square Building, Oakland.

MELROSE BUILDING MATERIAL Co., 4501 Tidewater Avenue, Oakland.

SCREENS

ROLL-AWAY WINDOW SCREEN Company, Eighth and Carlton Streets, Berkeley; 557 Market Street, San Francisco.

SEATING

*HEYWOOD-WAKEFIELD Co., 180 New Montgomery Street, San Francisco.

*GENERAL SEATING Company, 160 Second Street, San Francisco.

SHADE CLOTH

CALIFORNIA SHADE CLOTH Co., 210 Bayshore Boulevard, San Francisco.

SHINGLE STAINS

CABOT'S CREOSOTE STAINS, Gunn-Carle & Co., 20 Potrero Ave., San Francisco.

AUTO SPRINKLERS

GLOBE AUTOMATIC SPRINKLER Co., 665-6th Street, San Francisco.

STANDARD STEEL BUILDINGS

INDEPENDENT IRON WORKS, 821 Pine Street, Oakland.

STEEL FURNITURE

*GENERAL FIREPROOFING Company, 160 Second Street, San Francisco.

STEEL—REINFORCING

*SOULE STEEL Company, Army Street, San Francisco and Los Angeles.

GUNN-CARLE Company, Portrero Avenue San Francisco.

CECO STEEL PRODUCTS Co., 1280 Indiana Street, San Francisco.

*W. C. HAUCK & Co., 280 San Bruno Avenue, San Francisco.

*TRUSCON STEEL Company, 604 Mission Street, San Francisco.

STEEL—STAINLESS

REPUBLIC STEEL Corporation, Rialto Building, San Francisco; Edison Building, Los Angeles; White-Henry-Stuart Building, Seattle.

STEEL—STRUCTURAL

INDEPENDENT IRON WORKS, 821 Pine Street, Oakland.

JUDSON PACIFIC Company, C. F. Weber Building, Mission and Second Streets; San Francisco shops, San Francisco and Oakland.

HERRICK IRON WORKS, 18th and Campbell Streets, Oakland.

*MOORE DRYDOCK Company, Foot of Adeline Street, Oakland.

*WESTERN IRON WORKS, 141 Beale Street, San Francisco.

COLUMBIA STEEL Company, Russ Building, San Francisco.

STORE FIXTURES

MULLEN MFG. Co., 60 Rausch Street, San Francisco.

STORE FRONTS

KAWNEER MFG. Co., Eighth Street and Dwight Way, Berkeley.

TEMPERATURE REGULATION

JOHNSON SERVICE Company, Milwaukee, represented on the Pacific Coast by the following branch offices: 814 Rialto Building, San Francisco; 153 West Avenue, 34, Los Angeles; 1312 N.W. Raleigh Street, Portland, and 473 Coleman Building, Seattle.

TELEPHONES—INTERCOMMUNICATING

*PACIFIC TELEPHONE and TELEGRAPH Company, 140 New Montgomery Street, San Francisco.

TERMITE CONTROL—WOOD PRESERVATIVE

E. K. WOOD LUMBER Company, No. 1 Drumm Street, San Francisco; 4701 Santa Fe Avenue, Los Angeles; Frederick and King Streets, Oakland.

TILE—DECORATIVE, Etc.

*CAMBRIDGE TILE Mfg. Co., 1155 Harrison Street, San Francisco.

POMONA TILE MFG. Co., plant, Pomona, Cal.; Sales Rooms, 135 Tenth Street, San Francisco; 217 S. La Brea Avenue, Los Angeles; 6106 Roosevelt Way, Seattle.

GLADDING McBEAN & Co., 9th and Harrison Streets, San Francisco; 2901 Los Feliz Boulevard, Los Angeles.

KRAFTILE Company, Niles California, and 525 Market St., San Francisco.

*CALIFORNIA ART TILE Corp., Richmond, Cal.

TILE CONTRACTORS

*CAMBRIDGE WHEATLEY Company, 1155 Harrison Street, San Francisco.

TREE SURGERY

DAVEY TREE SURGERY Co., Ltd., Russ Building, San Francisco; Story Building, Los Angeles.

TRUSSES

*SUMMERBELL TRUSS Company, 405 Builders Exchange Building, Oakland.

*ARCH-RIB TRUSS Company, 608 Sixteenth Street, Oakland.

VALVES

"KRAMER" Flush Valves, MacDonald Hardware Manufacturing Co., 963 Harrison Street, San Francisco.

SLOAN VALVE Company, Chicago, Ill

SHAND AND JURS Co., Eighth and Carlton Streets, Berkeley.

VARNISHES

NATIONAL LEAD Company, 2240-24th Street, San Francisco. Branches and dealers in all principal Coast cities.

W. P. FULLER Company, San Francisco and principal Coast cities.

FRANK W. DUNNE Co., 41st and Linden Streets, Oakland.

VENTILATING EQUIPMENT

*THE B. F. STURTEVANT Company, 759 Monadnock Building, San Francisco

WALL BOARD

*WESTERN BUILDERS SUPPLY Company, 401 Fourth Street, San Francisco.

WATER HEATERS—GAS AND ELECTRIC

*WATROLA Corporation, Ltd., 1170 Howard Street, San Francisco.

*PITTSBURG WATER HEATER Co., 898 Van Ness Avenue, San Francisco.

*RUUD HEATER Company, 437 Sutter Street, San Francisco.

WESIX ELECTRIC HEATER Company, 380 First Street, San Francisco.

WINDOW SASH AND FIXTURES

"DALMO," SIMPLEX and "HAUSER" Casement Windows, MacDonald Hardware Mfg. Co., 963 Harrison Street, San Francisco.

*DETROIT STEEL PRODUCTS Co., 111 Sutter Street, San Francisco.

KAWNEER MFG. Company, Dwight Way and Eighth Street, Berkeley.

WINDOW SHADES

AEROSHADE Company, represented by W. R. Knight, 557 Market Street, San Francisco.

CALIFORNIA SHADE CLOTH Co., 210 Bayshore Boulevard, San Francisco.

INDEX TO ADVERTISEMENTS

*Indicates Alternate Months

A		K	
ALADDIN Heating Corp.	67	KAWNEER Company	9
AMERICAN Art Tile Company	76	KRAFTILE Company	4
AMERICAN Brass Company	7		
AMERICAN Electric Construction Company	76	L	
ANACONDA Copper Company	7	LANNOM Bros. Manufacturing Company	74
ANDERSON & Ringrose	74	LIBBEY, Owens, Ford Glass Company	*
ARCHITECTS Building	70	LINDGREN & Swinerton, Inc.	70
B		M	
BARTHOLD Soda Fountain Company	76	MacDONALD Hardware Manufacturing Company	4
BASALT Rock Company	70	MAPLE Flooring Manufacturers Association	*
BATEMAN, William	76	MOORE and Roberts	76
BUILDING Material Exhibit	70	MULLEN Manufacturing Company	71
C		N	
CASSARETTO, John	75	MUSTO Sons Keenan Company, Joseph	75
CELOTEX Corporation	*		
CLARK, N., and Sons	13	P	
CLINTON Construction Company	74	NATIONAL Lead Company	71
COCHRAN and St. John, Ltd.	76	NELSON, James A.	76
COLUMBIA Steel Company	*		
CRANE Company	*	P	
CROCKER, H. S.	71	PACIFIC Coast Gas Association	5
D		PACIFIC Coast Electrical Bureau	12
DAVEY Tree Surgery Company	70	PACIFIC Foundry Company, Ltd.	6
DELCO-FRIGIDAIRE	67	PACIFIC Manufacturing Company	72
DINWIDDIE Construction Company	75	PACIFIC Portland Cement Company	Second Cover
DOELL, Carl T., Company	75	PAN-AMERICAN Engineering Co.	73
DUNNE Company, Frank W.	75	PITCHER Company, E. C.	74
F		PITTSBURGH Plate Glass Company	*
FERRO-PORCELAIN Building Co.	74	PORTLAND Cement Association	Back Cover
FIRE Protection Engineering Company	69		
FULLER Company, W. P.	*	R	
FORMERER Cornice Works	73	REPUBLIC Steel Corporation	75
G		ROLL-A-WAY Window Screen Company	74
GLADDING, McBean & Company	11		
GOLDEN Gate Atlas Materials Company	72	S	
GUNN, Carle & Company	2	SANTA Maria Inn	71
H		SIMONDS Machinery Company	75
HANKS, Inc., Abbot A.	73	SISALKRAFT Company	72
HARER-Perry Company	70	SMITH Lumber Company	75
HAWS Drinking Faucet Company	72	STANLEY Works	69
HERRICK Iron Works	73	T	
HOPKINS, Preston P.	76	TORMEY Company, The	75
HOTEL CLAREMONT	71		
HOTEL CLARK	75	U	
HUNT, Robert W. Company	71	UNITED States Steel Products Company	*
HUNTER and Hudson	75		
I		V	
INCANDESCENT Supply Company	72	VAUGHAN-G. E. Witt Company	73
INDEPENDENT Iron Works	74		
J		W	
JENSEN & Son, G. P. W.	71	WESIX Electric Heater Company	73
JOHNSON, S. T., Company	68	WOOD, E. K., Company	68
JOHNSON Service Company	3	WESTERN Asbestos Company	70
JUDSON Pacific Company	70		

THE
ARCHITECT
AND
ENGINEER

MAY
1938



NEVER GETS OUT OF
ADJUSTMENT

S
I
N



... BECAUSE
there's nothing to adjust

• The North Star never requires adjustment. Neither does the Sloan "Royal" Flush Valve. There is no place on either for an adjustment set-screw. • The Sloan Royal Flush Valve automatically delivers the exact requirement of water every time the handle is tripped. Neither accident nor malice can change this constant performance. • It is this mathematical dependability that puts Sloan so far in the lead it is really conservative to say: "More Sloan Valves are sold than all other makes combined."

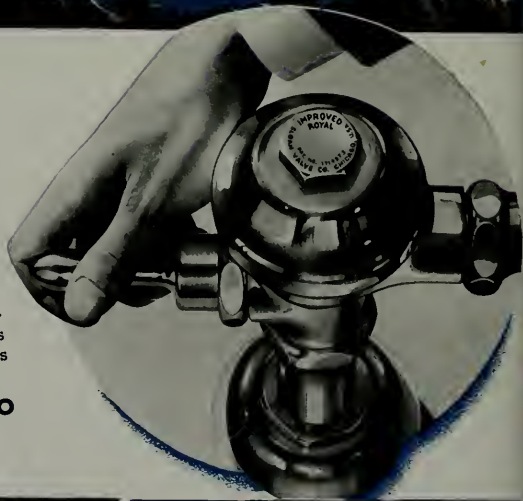
SLOAN VALVE COMPANY • CHICAGO



SLOAN *Flush* VALVES

MAKERS ALSO OF THE "STAR"  "NAVAL"  AND "CROWN"  VALVES

THE ARCHITECT & ENGINEER

May .. 1938 .. Contents

COVER

DETAIL OF ENTRANCE, HUNTINGTON BEACH ELEMENTARY SCHOOL
Allison & Allison, Architects

EDITOR

Fred'k W. Jones

CONSULTING BOARD OF EDITORS

ADMINISTRATION BUILDING, CHAFFEY JUNIOR COLLEGE,
ONTARIO, CALIFORNIA
Allison & Allison, Architects

FRONTISPIECE

Architectural—

Arthur Brown Jr.
Frederick H. Meyer
Timothy L. Pflueger
Will G. Corlett
Harry Michelsen
Lewis P. Hobart
David C. Allison
Gordon B. Kaufmann
Harris C. Allen

Engineering—

H. J. Brunner
L. H. Nishkian
William Adrian
Wm. H. Popert
Homer N. Hadley
Geo. E. Atkins

Assistant Editor—

Edgar N. Kierulff

Advertising Manager—

J. Leslie Meek

Architects' Reports—

Vernon S. Yollop

THE ARCHITECT AND ENGINEER, INC., 68 Post Street, San Francisco, EXbrook 7182. President, K. P. Kierulff; vice-president, Frederick W. Jones; secretary, L. B. Penhollow. Los Angeles office, 832 W. Fifth Street. Published on the 12th on each month. Entered as second class matter, November 2, 1905, at the Postoffice at San Francisco, California, under the Act of March 3, 1897. Subscriptions, United States and Pan America, \$3.00 a year; Foreign countries, \$5.00 a year; single copy, \$.50.

TEXT

RECENT ARCHITECTURE OF ALLISON & ALLISON	13
Irving F. Morrow	
THE NEW FEDERAL PROGRAM FOR MULTI-FAMILY HOUSING	35
C. A. West	
BUILDING RECOVERY DISCUSSED BY INSTITUTE DELEGATES	37
EXTRA!—CLIENT AND ARCHITECT HAVE LIKE IDEAS FOR HOME	39
Joshua H. Vogel	
FAILURE OF THROUGH TRUSS BRIDGES OF NARROW ROADWAY WIDTH	45
P. W. Panhorst	
WORLD'S FAIR BUILDERS—T. F. PFLUEGER	48
Mark Daniels	
CALIFORNIA NEEDS BETTER FLOOD CONTROL	49
Edward Hyatt	
ADOBE CONSTRUCTION	51
WITH THE ARCHITECTS	53

PLATES AND ILLUSTRATIONS

WORK OF ALLISON & ALLISON

University of California of Los Angeles	14-17	Chaffey Union High School, Ontario	25
Francis Willard Junior High School	18	Pomona College, Claremont	26-27
Huntington Beach Elementary School	19	Laguna Beach Elementary School	28-29
Van Nuys High School	20-21	Los Angeles Junior College	30
Santa Ana High School	22-23	U. S. Post Office, Merced	31
Chaffey Memorial Library, Ontario	24	First Congregational Church, Los Angeles	32-34
Residence of Mrs. Bliss		L. W. Crawford, Architect	36
Residence of Mr. and Mrs. A. I. Launder, Seattle		Joshua H. Vogel, Architect	39-40
Residence of Mr. and Mrs. John Holman, San Marino		H. Roy Kelley, Architect	42-43
Damaged Bridges		Timothy F. Pflueger	45-47
Timothy F. Pflueger			48

Notes and Comments

The desire of contractors to be present when bids on building contracts are opened is not opposed by the majority of the architects who have answered a questionnaire sent out by the American Institute of Architects, it was announced at the seventieth annual meeting of the Institute held in New Orleans, in April.

The questionnaire was sent out by request of the Associated General Contractors of America. The contractors wanted information as to the attitude of the architects toward the presence of bidders at the opening of bids.

Replies received show that 199 members of the Institute have no objection to the presence of bidders, while 126 do object. However, only 85 of the architects customarily permit bidders to be present, while 242 do not. Only 95 architects said they did not usually mail out notices to bidders regarding the bids received, while 97 said they did not post the bids in their offices. Sixty-one objected to mailing out or posting in their offices the list of bidders and the bids received.

The Institute's Committee on Construction Industry Relations, headed by William Stanley Parker of Boston, decided, after analyzing the replies to the questionnaire, that the objection of the architects' clients to the presence of bidders, and lack of space to accommodate large gatherings, were deciding factors in many cases. A total of 140 architects said clients had indicated unwillingness to have bidders present at the opening of bids, while 161 reported that contractors had asked to be present.

"In general there are strong opposing convictions expressed as to the desirable policy," the Committee reported. "Some claim it is the owner's private business, and bidders have no rights, while the presence of bidders might make possible undesirable and embarrassing practices by some.

"Others say it is only fair to bidders, who have spent time and money on the bid, to be present at the opening. Some admit the owner prefers to open privately so as to be able to engage in subsequent negotiations with less embarrassment. These negotiations are not always improper, but merely the consideration of personalities and preferences.

"It appears to be falsely assumed by many that the presence of the bidders at the opening means that the owner must make the award immediately. This, of course, is not true, and the contractors do not so claim. The owner, having opened the bids, can then take them under advisement. That is all the contractors desire."

The conviction long held by architects, producers, and contractors that a stabilized return of good business conditions can never be accomplished until the building industry

is put on its feet again is now generally recognized by business, administrative, and executive groups.

It is further well recognized that housing represents the greatest unsatisfied need in building, and possibly affords the approach most susceptible to stimulation in an organized program of recovery.

OREGON Chapter of Architects, through the offices of its past president, Jamieson Parker is receiving merited praise for having successfully "sold" its leading newspaper, the Portland Oregonian, on good design. The Chapter has succeeded in ousting a "plan factory" house design department that appeared every Sunday in the Oregonian and in its place supplies weekly fresh designs of buildable houses with suitable text. The agreement with the publishers covers a period of 25 weeks with a promise to continue the arrangement indefinitely as long as suitable material is available.

Some local interest is attached to the recent announcement that there will be a building of contemporary art at the New York World's Fair, with the feeling that our own Fair might offer a similar attraction. In New York a Fair-built building, originally intended to house community arts, will be

Hundreds of Homes

being planned under the

FEDERAL HOUSING ACT

will be more comfortable,
more livable, more economical to heat in cold weather, if

INSULATED with CABOT'S
QUILT

An effective sound deadener . . .
vermin proof and fire retardant.

GUNN CARLE & CO.

San Francisco
20 Potrero Ave. UNDERhill 5400

made available for the display of the works of living American artists. The building will provide 40,000 square feet of space and make it possible to show at least 800 contemporary works of art, including sculpture paintings, and graphic art. Decision to build ends satisfactorily a controversy in art circles concerning the previous verdict of the Fair not to have an arts building and to leave the art exhibition program to the existing museums in Manhattan and Brooklyn. While the scope of the exhibit as now planned does not embrace the "old masters" it is said to provide ample quarters for living artists' works and satisfies the demands of the art groups.

A BERKELEY banker is authority for the statement that a noticeable change has developed toward the employment of competent architectural service in the design of small houses. He says prospective homeowners, seeking building loans and banker's advice, are definitely "sold" on architectural service and are willing to pay well for such service. It would seem from this that at last the public is beginning to realize the folly of building from stock plans or designs by contractors who promise to save architects' fees; then build houses sans re-sale value.

About eighty years ago at Oxford, England, several illustrious men of arts spent months in painting murals and other decorative pieces on the walls of the Oxford Union. William Morris, D. G. Rossetti, Burne-Jones and other notables toiled mightily at the work—only to find that it is not wise to paint without distemper on naked walls. The paintings soon fell into a sad ruin of cracks and crannies, peeling and fading.

Going back further—to Neolithic man, daubing away in an effort to brighten up the walls of his cave—one finds that since their days artists have endeavored to find new materials on which to paint for better execution and perpetuation of their work.

No really permanent material was discovered for the purpose. Nothing remains today of the Egyptian and Greek paintings. The Thelateristic Frescoes are about the earliest known paintings extant. The process of Fresco painting is very difficult, requiring great skill, and when the walls crack, crumble or are destroyed the paintings sink into oblivion.

A number of artists are turning today to a new kind of material produced by industrial research. This is a galvanized sheet metal having a fine phosphate coating which provides an excellent painting surface for the artist's needs. Its cost is said to be lower than any other of the best available materials. It is durable and sulphur and other atmospheric elements cannot attack the paint from the rear.



For Architects...

A NEW BATHROOM PLANNING SERVICE

Here's a new service available to Architects—a service designed to offer practical, workable suggestions and ideas on bathroom planning both for the simple, inexpensive room as well as for the more costly one in the finer home.

Crane Co. has made a comprehensive study of basic bathroom types and fixture arrangements as well as color effects obtainable in standard materials, that harmonize with bathroom fixture colors. All of this information, showing these materials in actual room settings in colors that are obtainable and giving the manufacturer's name and identification, is a part of this new service.

Complete bathrooms, including all the basic types, have actually been built and photographed in color. These, together with many variations, are illustrated in the new Crane Planner. Here, right at hand, is a wealth of valuable information on color harmony and decorative treatment immediately available to every architect.

You are invited to use the Crane Bathroom Planner as extensively as you wish—its use will save you hours of time in your planning. Step into any Crane Display Room or invite your clients in if you like. The Bathroom Planner will assist them in making their decision.



CRANE

VALVES • FITTINGS • PIPE
PLUMBING • HEATING • PUMPS



CRANE CO. • GENERAL OFFICES: 836 SOUTH MICHIGAN AVENUE • CHICAGO

NATION-WIDE SERVICE THROUGH 134 BRANCHES AND MORE THAN 500 WHOLESALERS

BENJAMIN FRANKLIN STATUE IS UNVEILED

Heroic monument to famous statesman, sculptured by James Earle Fraser, stands in Franklin Hall, Philadelphia. The white marble pedestal, shown below, weighs 90 tons.



● ANNOUNCING

MacDONALD HARDWARE MANUFACTURING CO.

NOW EXCLUSIVE MANUFACTURERS AND DISTRIBUTORS OF

● **DALMO
WINDOWS
SIMPLEX**

● **HAUSER
CASEMENT
WINDOWS**

● **KRAMER FLUSH VALVES**

MacDONALD HARDWARE MANUFACTURING CO.

ENGINEERED HARDWARE

963 HARRISON ST.

SAN FRANCISCO

"Beautiful, Sturdy, Hard Maple... Is Still the Most Economical School Floor!"

say **N. CHESTER SORENSEN**, N. Chester Sorensen Co., Architects, Detroit

Hard Maple was used in both the classrooms and gymnasium of the Western High School, Detroit, Mich. N. Chester Sorensen Co., Architects.

The gymnasium shown at right owes more than cheerful daylight to its light-reflecting floor. Year after year, this floor will withstand the constant wear of scuffing feet and scraping athletic equipment. It's Hard Maple!



"AFTER personally seeing such wide use of Hard Maple floors in school rooms for over twenty years," writes Mr. Sorensen, "it seems to me a remarkable tribute that even after this elapsed time this beautiful, sturdy material is still being accepted today as the most economical floor.

"I have seen several substitutes come and go, but for appearance, maintenance, and economy, Maple Floors in school rooms stand ahead of all flooring."

Architects know how important proper choice of flooring is to every school. So many factors must be considered—economy as well as appearance—low cleaning costs as well as low maintenance costs—everyday comfort as well as long-life. That Northern Hard Maple thoroughly satisfies all requirements, is proved by its continuous use in schools, year after year.

There is no substitute for Hard Maple's smooth, lasting surface—so cheery with its

light-reflecting natural beauty*—so resistant to abrasion and indentation—so easily cleaned and maintained. Hard Maple—tough-fibred, tight-grained—does not splinter, splinter or develop ridges—provides firm anchorage for desks—makes alterations easy. Warm, dry and resilient, it favors health and efficiency.

Architects know that long after many flooring materials would need replacement or repair, Hard Maple will still be giving satisfactory service. Before you build or remodel, check this superior flooring against your requirements. Specify **MFMA**** Northern Hard Maple (in strips or blocks), the only flooring whose grading is MFMA supervised.

MAPLE FLOORING MANUFACTURERS ASSOCIATION

1790 McCormick Building, Chicago, Illinois

See our catalog data in Sweet's, Sec. 11 '76. Write for our folder on "Heavy Duty Finishes" for old and new Maple floors.

**To be sure of Association guaranteed grading, specify and look for the MFMA trademark (indented and stamped). The following manufacturers are licensed to use it:

- Beck, August C. Co., Milwaukee, Wis.
- Brown Dimension Co., Manistique, Mich.
- Bruce, E. L. Company, Memphis, Tenn. (Mill at Reed City, Mich.)
- Connor Lumber & Land Co., Laona, Wis. (Sales Office, Marshfield, Wis.)
- Farrin Lumber Co., M. B., Cincinnati, O.
- Holt Hardwood Co., Oconto, Wis.
- Kerry & Hanson Flooring Co., Grayling, Mich.
- Kneeland-Bigelow Co., Bay City, Mich.
- Kneeland-McLurg Flooring Co., Phillips, Wis.
- North Branch Flooring Co., Chicago, Ill.
- Oval Wood Dish Corp., Tupper Lake, N. Y.
- Robbins Flooring Co., Rhineland, Wis.
- Stephenson Company, L., Wells, Mich.
- Wells, J. W. Lumber Co., Menominee, Mich.
- Wisconsin Land & Lbr. Co., Hermansville, Mich.
- Yawkey-Bissell Lumber Co., White Lake, Wis.

Floor with MFMA Maple (NORTHERN HARD)

*** 3 WAYS YOU CAN USE MAPLE:**
1. In unselected color (natural finish) under standard grading. 2. Grouped for color tone (as "White Clear" or "Brown Clear") and for pattern effects. 3. Color finished—in Early American, Spanish Brown, Ebony Black, and other colors of startling beauty—to match any decorative scheme.

WHERE HOUSE AND GARDEN BLEND AS ONE



RESIDENCE OF MR. AND MRS. CHARLES E. MILLIKAN,
GLENDALE, CALIFORNIA
ARTHUR R. HUTCHASON, ARCHITECT

THE photographs adequately illustrate a home typifying the California ideal. Low and rambling, the house is a splendid example of unity between dwelling and gardens. Mr. and Mrs. Charles E. Millikan are the owners and Arthur R. Hutchason the architect. Ruth Shellhorn was the landscape architect. The house occupies a hillside site above Glendale in Southern California.

Due to the slope of the property, the plan is unusual. The main portion of the house is on an intermediate garden level, while the bedrooms are grouped in a two-story wing which gives proper separation for the sleeping quarters. To the rear the land slopes into a canyon, on the sides of which are century-old oaks. A winding path leads down through terraced gardens to a playground, barbecue and garage on the lower level.

General shape of the house provides ample light and air for all rooms and easy access to the gardens. The living room opens wide upon the verandah and the dining room location permits meals to be served out of doors conveniently. The kitchen is hidden from the dining room by a breakfast room which functions also as a serving pantry.

The service portion is ideal. In the kitchen, corner windows above the sink and dishwasher, which operates hydraulically, overlook the rear entry, while on the other two sides are the modern gas range and gas re-

frigerator. A desk and telephone give added convenience. An automatic storage type gas water heater assures adequate hot water supply. Heat is provided by forced air ventilation from two gas furnaces.

A unique feature of the house is a "clothyery," a word coined by the owner. It is a "room of all trades" to handle laundry, sewing and flowers. All mechanical equipment in this room is carefully concealed under work counters.



ALL GAS KITCHEN IN RESIDENCE OF
MR. AND MRS. CHARLES E. MILLIKAN,
GLENDALE, CALIFORNIA

NOT 2000 A.D. — BUT NOW

GAS-EQUIPPED BUILDING
REVEALS FUTURE TRENDS

COMPARE this beautiful structure with the ugly "business block" of a previous generation! Even more striking is the contrast inside: Trim, spotless cleanliness in the boiler room (thanks to modern gas fuel)—a combined heating and ventilating system under complete automatic control, with provision for summer cooling and ideal working conditions because of uniform temperature and constantly changed, filtered air—acoustically treated ceilings—a roof garden for employes' recreation.

☆ It takes no crystal gazing to foresee the future trend in design and equipment—with gas fuel playing a stellar role in every step forward.

GAS
THE MODERN FUEL



FARMERS INTER-INSURANCE EXCHANGE BUILDING, Los Angeles ☆ Walker & Eisen, Architects ☆ W. S. Kilpatrick & Co., Heating Contractors ☆ Equipped with gas-fired, full mechanical heating and ventilating system, distinguished by low initial cost, high efficiency and operating economy.

QUICK • CLEAN • CONTROLLABLE • DEPENDABLE • ECONOMICAL

PULSE OF THE READER

"MEN IN SMOCKS"

Dear Editor:

I was very much intrigued by the idea contained in the April article entitled "Men in Smocks," but Mr. Gooson's outline for a scenario is simply Col-Lousy. The most prosaic of architects has a more romantic background than is herein described. Let the story be more like Maugham's "Of Human Bondage" rather than "Men in White"—epical in treatment, with the hunger of youth, ambition of the 20s, frustration of the 30s, success coupled with bitterness in the 40s and 50s. I could put in a few touches on the mental latrines I've slept in.

You should pursue the idea further—invalidate a contest inviting architects to submit outlines of a story. I wish I were not so busy as I would like to write something myself.

Yours,

ROI L. MORIN, A.I.A.

Portland, Ore.

PLEASED WITH ARTICLE

Dear Editor:

A friend of mine showed me the April issue of your magazine, showing the Rosenberg Department Store Building on the front cover, with a descriptive article, together with photographs of some of our departments as a story feature.

To say that I was immensely pleased with this exploitation and proud to have our store presented in such a wonderful manner in your magazine, would be to put it mild, indeed. Publicity, such as you have given us in this story, is certainly a fine boost for Santa Rosa and ourselves as well.

We would like very much to have you send us copies of this issue and will ask you that you kindly bill us for same.

Thanking you for your courtesy and with every wish for your continued success, we are

Yours very truly,

ROSENBERG & SON,

By Fred S. Rosenberg,

Santa Rosa, Cal., April 21, '38

A WARNING

Dear Editor:

Construction is the largest single business enterprise in all industry, under normal conditions. It has, however, been depressed to a fifth-rate position by political mal-distribution of taxation and speculative financing interest charges.

Construction assessments carry more than 75 per cent of the nation's taxation, and represent only 5 per cent of the nation's business today. Normally,

the construction industry could employ 10 to 15 million workers to supply the natural demand for buildings, the construction of which has been postponed by many years of depression. The natural expansion of the industry would absorb all the unemployed on the streets of America, within two or three months.

It is the social duty and responsibility of every person to demand that the base of taxation be transferred from construction to the actual social government services that are rendered the taxpayer. An itemized tax bill or invoice must be demanded, which will expose for direct examination and verification the detailed operating expenses of the community. The per capita cost of schools, libraries, police, fire protection and other similar services, can be computed accurately from the statistics of past years by public officials.

The added advantage of this system is that each community will, in fairness, have to compete for its population on the merit and efficiency of its government, and thus assure the taxpayer value for the dollar expended.

Unless social government is placed upon a scientific business basis, similar to that employed in private enterprise, the depressions which we are passing through are insignificant to those ahead of us.

Very truly yours,

GEZA SZMAK,

New York, March 24, '38.

COPYRIGHT PHOTO

Dear Editor:

About a month ago I received a letter from your office in reference to my photograph of the Kirk Thompson house in Spokane, Washington, which was published in your January issue. You stated that you had published this photograph without knowledge that it was copyrighted; therefore no by-line credit was given in the publication to acknowledge copyright of the photograph. In the same letter you suggested that you would publish this photograph again in the March issue of the same publication, acknowledging copyright in this issue. As per my letter in answer to your proposition, I agreed to these terms.

I have just seen the March issue of "The Architect and Engineer" and note that the picture has been published, but again, the copyright acknowledgement has been omitted. I have been distributing this photograph for only the cost of reproduction, receiving no payment from the sale of the picture and have done so

as a mere courtesy to G. A. Pehrson, the architect of the building. The only benefit I receive from this picture, therefore, is the possible publicity I receive through its being published with by-line credit in my name.

I am sorry this item was overlooked and hope that you will adjust this matter satisfactorily at your earliest convenience.

Very truly yours,

L. G. EVANOFF,

Seattle, Wash., March 29, 1938.

Editor's Note: Through a regrettable oversight mention of Mr. Evanoff's name under the copyrighted photograph was omitted in the March issue.

APPRECIATION

Dear Editor:

I take this opportunity to thank you for your efforts in publishing in the April issue of **The Architect and Engineer** a recent talk given by me before the San Francisco Section of the American Society of Civil Engineers.

The generous space which you allowed for the illustrations has stimulated further interest in the public's mind for the 1939 Golden Gate International Exposition.

Very truly yours,

JOHN J. GOULD,

Chief, Div. of Structural Engineering, San Francisco.

AGAINST SLUM CLEARANCE

Dear Editor:

At the request of our Executive Director, Mr. Dick J. Richards, we are enclosing herewith a copy of a letter sent to Hon. Robert F. Wagner and Hon. Henry B. Steagall.

We believe that the suggestions offered in this communication will be of interest to your readers.

Respectfully Yours,

NAT'L HOME BUILDING BUREAU,
Berkeley.

Juanita J. Lyon, Secretary.

Editor's Note: Portions of Mr. Richards' letter are printed herewith:

May we again be permitted to offer some suggestions concerning Senate Bill 1685 known as the Wagner-Steagall Bill, which created the United States Housing Authority. Some time ago we sent you photostatic copies of the houses planned by this organization, then known as the National Housing Bureau. Since that time we have changed the name to the National Home Building Bureau. We will refer to these houses later on in this communication.

We believe that the United States Housing Authority and the Federal Housing Administration with its recent amendments are the two best pieces of legislation which have been passed for many

(Please turn to Page 73)



Residence of Dr. George Calingaert, Detroit, Michigan;
J. Robert F. Swanson, Dearborn, Michigan, architect.

GLASS

distinguishes the modern house

● Today's trend in residential architecture prescribes the generous use of glass. Larger window areas...picture windows...corner windows...dominate design of the modern house—spread sunlight and create a cheerful atmosphere within.

With glass used more extensively than

ever before, its quality becomes a matter of paramount importance. Libbey-Owens-Ford Quality Glass is today, as it has been for many years . . . Clearer, Brighter and Flatter than any that the industry has ever offered.

Libbey-Owens-Ford Glass Company, Toledo, O.

LIBBEY · OWENS · FORD *QUALITY GLASS*



LOOK FOR THE LABEL

For Any
Automatic Heating
or
Air Conditioning
Problem

DELCO-FRIGIDAIRE Offers the Most Complete Line of Equipment—



Here is the
DELCO CONDITIONAIR
typical of the General
Motors value in the Delco-
Frigidaire line. Fired by
oil or gas, this famous
product furnishes com-
plete winter or year
'round air conditioning
at remarkably low cost.

Ask For **FREE** Specifications of the Delco Conditionair Or Other Heating and Air Conditioning Products

The Delco-Frigidaire line of equipment is built and backed by General Motors, providing quick and easy public acceptance.

Most important product to architects is the Delco Conditionair for oil or gas, offering years of really economical operation because of its quality construction. It automatically heats, humidifies, filters and circulates healthful air throughout the house. And it provides your clients with protection against early obsolescence—because provision can easily be made for adding low-cost summer air conditioning at any time in the future.

For radiator systems Delco-Frigidaire offers the efficient Oil or Gas Automatic Furnace utilizing the Im-Pak-Tor method of extracting heat from the hot gasses before they can escape.

The Delco Oil Burner, famous for its quality and

dependability, furnishes low cost automatic heat for years to come. And the new Delco Stoker features several new developments by General Motors.

Complete Line of Air Conditioning, too

Delco-Frigidaire air conditioning equipment ranges in size from small self-contained units for single rooms to equipment for efficiently air conditioning large buildings. Delco-Frigidaire has had a unique experience in this wide range of installations.

FREE HELP TO ARCHITECTS

Complete detailed specifications on all Delco-Frigidaire equipment are available upon request. No obligation of course. And feel free to call on Delco-Frigidaire at any time for aid in any plans calling for automatic heating or air conditioning.

ALADDIN HEATING CORP.

DELCO-FRIGIDAIRE DEALER

5107 Broadway

Oakland, California

Telephone OLYmpic 5424

GLAZED TERRA COTTA WALL UNITS



Typical Wards—showing use of Glazed Terra Cotta Wall Units

26,000 SQUARE FEET . . . N. CLARK & SONS—GLAZED TERRA COTTA WALL UNITS . . . used in all wards and corridors, also in bath and toilet rooms, diet kitchens, dining rooms, examination rooms, utility rooms and special treatment rooms.

There is a place in every building for Glazed Terra Cotta Wall Units . . . available in a wide selection of shapes and colors. The impervious hard glazed surface eliminates maintenance costs.

For economy, simplicity and flexibility in use, the low cost of N. CLARK & SONS—GLAZED TERRA COTTA WALL UNITS makes them available for the moderate type of installation . . . whereas their high quality permits their use in place of more expensive materials.

Illustrated handbook ready now . . . ask for it.

PSYCHOPATHIC HOSPITAL

Seven-story building . . . newest addition to

City and County Hospital

San Francisco

Martin Rist, Architect

Anderson & Ringrose, General Contractors

White & Gloor, Masonry Contractors

N · C L A R K & S O N S

116 NATOMA STREET · SAN FRANCISCO

Los Angeles . . . Portland . . . Salt Lake City



ADMINISTRATION BUILDING, CHAFFEY JUNIOR COLLEGE
ONTARIO, CALIFORNIA
ALLISON & ALLISON, ARCHITECTS

RECENT ARCHITECTURE OF ALLISON & ALLISON

By IRVING F. MORROW

OF the old dictum that the history of civilization may be read in the history of architecture there are numerous possible exemplifications. Revealing analogies may be pointed out in the sphere of taste and general attitude toward life; material activities such as industrial and constructional methods may be investigated; and so on. But the most direct of possible applications—inquiry into the purposes for which people build—is not the least illuminating.

The major preoccupation of every early architecture—primitive; oriental; occidental down to the late Middle Ages—has been religious. After that have come programs of general social utility—open air public theaters; fora and other assembly places—and residences for rulers and wealthy individuals. The Renaissance only shifted a larger emphasis to private programs, without adding any conspicuous new ones.

Recent times have witnessed a wholly new phenomenon—a preponderance of emphasis upon entirely new programs. It is a commonplace of even newspaper supplements to point out that ours is an age of commercial and industrial architecture. But it is questionable if any one aspect of our times is more significant than its unprecedented interest in education. Schools have increased in bewildering numbers; favored institutions have grown to fantastic, even unmanageable sizes; and the buildings devoted to these educational activities have increased in complexity and functional differentiation beyond the dreams of educators of even

a generation ago. Formerly the educational program required of the architect little more than the provision of rudimentary shelter and circulation. Now architecture assumes a definite role in the planning and operation of this extensive scheme.

For years Allison & Allison have been identified with school architecture throughout Southern California and even north to the borders of San Francisco. Without presuming to disturb the dust on venerable magazine files to ascertain dates, I can distinctly recall that one of my early assignments for an architectural journal was an appraisal of their early and even then not inconsiderable volume of work. Since those unverified but assuredly distant days their devotion to educational problems has been unbroken, varying only with the chequered economic movements of the intervening period. They deserve consideration as part of the educational system.

And here, as above (only adopting a more modest unit of time), the course of their output is seen to be not unrelated to the general course of the community's attitude and thought. From compositions based on historic procedures, though never subservient to specific historic example, one witnesses a gradual relaxation of the retrospective motive, while the logic of current structural requirements introduces a trend toward the more modern types of design.

The work here shown is relatively recent. Specific comments appear in the captions accompanying the several illustrations.



UNIVERSITY OF CALIFORNIA AT LOS ANGELES—GENERAL PLAN
 To date several architects have collaborated on this scheme, as follows—

- | | |
|--|--|
| A—Library, Geo. W. Kelham, Architect | G—Wm. G. Kerckhoff Hall, Allison & Allison, Architects |
| B—Josiah Royce Hall, Allison & Allison, Architects | H—Men's Gymnasium, Geo. W. Kelham, Architect |
| C—Physics-Biology Building, Allison & Allison, Architects | I—Women's Physical Education Building, Allison & Allison, Architects |
| D—Chemistry-Geology Building, Geo. W. Kelham, Architect | J—Mira Hershey Hall, Douglas MacLellan, Architect |
| E—Educational Building, Geo. W. Kelham, Architect | K—Administration Building, Allison & Allison, Architects |
| F—Mechanical Arts Building, Marston & Maybury, Architects | L—Open Air Theater, Allison & Allison, Architects |
| President's House, North of Royce Hall, Reginald D. Johnson, Architect | |

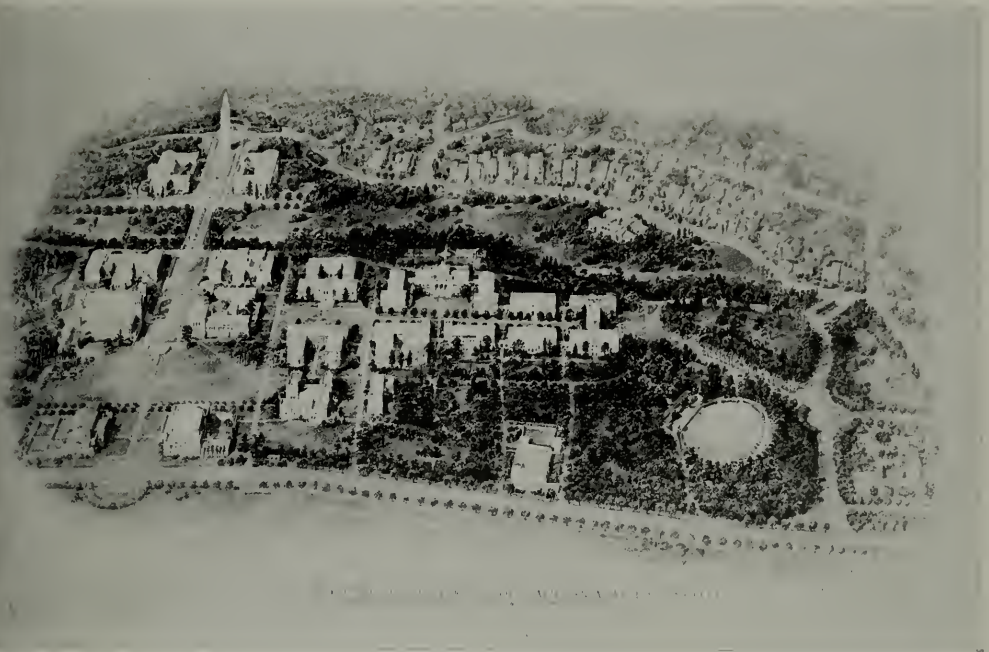

UNIVERSITY OF CALIFORNIA AT LOS ANGELES—AERIAL VIEW

THE point of view of this perspective is below and on the middle of the plan on the opposite page. It is therefore oriented precisely as is the plan, and buildings may be readily identified.

THE University of California at Los Angeles is one of the most extensive and important group schemes in the State. As the plan shows, the development is still far from complete. The style, an adaptation of north Italian Romanesque using brick and stone combined, was set by the initial buildings designed by the late George W. Kelham and by Allison & Allison.



UNIVERSITY OF CALIFORNIA AT LOS ANGELES—OPEN AIR THEATER
ALLISON & ALLISON, ARCHITECTS

The uninterrupted sweep of the plan, the restful gradient of the section, the suppression of superfluous construction, the deft intermingling of structure and planting, are all conspicuous in this theater design. Because of the out-of-door spaciousness, lack of insistence on Architecture with a capital A, and the adroit relationship between the natural and the artificial, it is one of the most successful pieces of recent landscape architecture. As time is of the essence of landscape development, its immediate construction is certainly to be desired.



UNIVERSITY OF CALIFORNIA AT LOS ANGELES
WOMEN'S PHYSICAL EDUCATION BUILDING
ALLISON & ALLISON, ARCHITECTS
This building illustrates the general style of the group



FRANCES E. WILLARD JUNIOR HIGH SCHOOL, SANTA ANA, CALIFORNIA
ALLISON & ALLISON, ARCHITECTS

The earlier school buildings of Allison & Allison have fallen in general into three classes:

- (a) related to the tradition of the north Italian Romanesque;
- (b) related to the sources of the historical California Spanish, (as in this example and that shown in the frontispiece);
- (c) a half naïve, half sophisticated, well-bred Americanism, (as in the example shown on pages 28 and 29).

All exhibit the same easy assurance, not unfriendly dignity, and satisfied relation with the ground.



CENTRAL ELEMENTARY SCHOOL, HUNTINGTON BEACH, CALIFORNIA
ALLISON & ALLISON, ARCHITECTS

As one more contribution to the "battle of the roofs" it may be observed that when the top horizontal slab goes upon a concrete building as a structural diaphragm, the addition of a pitched roof becomes superfluous, and therefore inadmissible where reasonable economy is concerned. It is this practical consideration which is largely responsible for the trend toward modernism in the above school, as well as those on the four pages following and on page 30.



CLASSROOM BUILDING, VAN NUYS HIGH SCHOOL, VAN NUYS, CALIFORNIA
ALLISON & ALLISON, ARCHITECTS



ADMINISTRATION BUILDING, VAN NUYS HIGH SCHOOL,
VAN NUYS, CALIFORNIA
ALLISON & ALLISON, ARCHITECTS



SANTA ANA HIGH SCHOOL, SANTA ANA, CALIFORNIA
ALLISON & ALLISON, ARCHITECTS



SANTA ANA HIGH SCHOOL, SANTA ANA, CALIFORNIA
ALLISON & ALLISON, ARCHITECTS



CHAFFEY MEMORIAL LIBRARY,
CHAFFEY JUNIOR COLLEGE,
ONTARIO, CALIFORNIA

ALLISON & ALLISON, ARCHITECTS

The Mexican Colonial style was used
in this institution to
correspond with previous buildings.

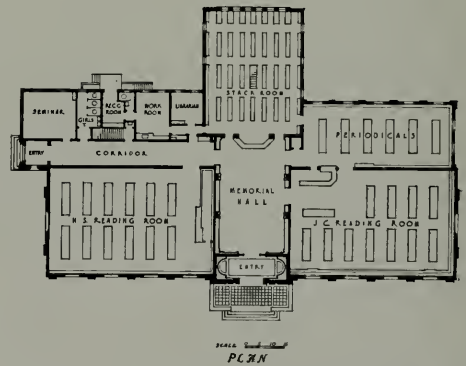



AUDITORIUM BUILDING, CHAFFEY UNION HIGH SCHOOL,
ONTARIO, CALIFORNIA
ALLISON & ALLISON, ARCHITECTS



BLAISDELL HALL,
POMONA COLLEGE,
CLAREMONT, CALIFORNIA

ALLISON & ALLISON,
ARCHITECTS

Plot plan at right. Plan: of present
building on
opposite page.

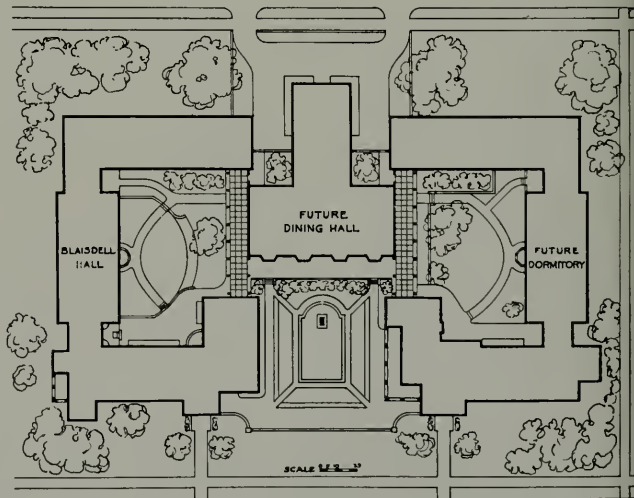



BLAISDELL HALL, POMONA COLLEGE, CLAREMONT, CALIFORNIA
 ALLISON & ALLISON, ARCHITECTS



GROUND FLOOR PLAN



SECOND FLOOR AND TOWER PLAN

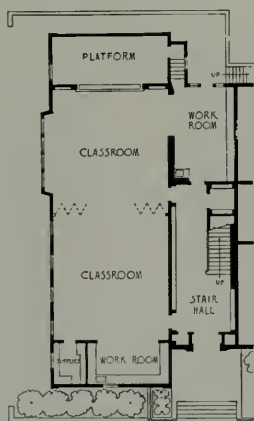

ELEMENTARY SCHOOL, LAGUNA BEACH, CALIFORNIA
ALLISON & ALLISON, ARCHITECTS

The plan of the lower floor is at the left; the plan of the main floor (at the same scale) is on the opposite page.

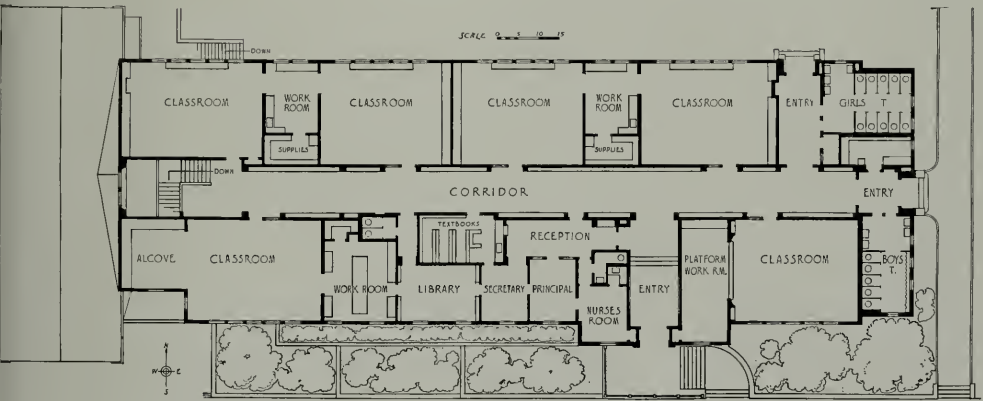

ELEMENTARY SCHOOL, LAGUNA BEACH, CALIFORNIA
ALLISON & ALLISON, ARCHITECTS



PROPOSED LOS ANGELES JUNIOR COLLEGE GROUP

LIFE SCIENCES BUILDING (above) AND AERIAL VIEW OF GROUP (below)
LOS ANGELES JUNIOR COLLEGE, LOS ANGELES, CALIFORNIA
ALLISON & ALLISON, ARCHITECTS



UNITED STATES POST OFFICE, MERCED, CALIFORNIA
ALLISON & ALLISON, ARCHITECTS

There are people who believe that Allison & Allison have never built anything but schools. Of course those who have watched architecture in California know perfectly well that some of their most distinguished work is to be found in clubs, commercial buildings, industrial buildings, churches, and other types. This Post Office will serve as a "believe it or not" exhibit to convince the skeptical.



GOTHIC CHURCH

The groined Gothic vault, outstanding feature of the great cathedrals of France and England, is reflected in the physical characteristics of the First Congregational Church of Los Angeles . . . comparable to the Parish Church of Britain.

Fortunate in its commanding site, the great mass of the central tower dominates the composition. Round about and below the main building are massed the lesser forms—the chapel, the church school, the organ chamber.

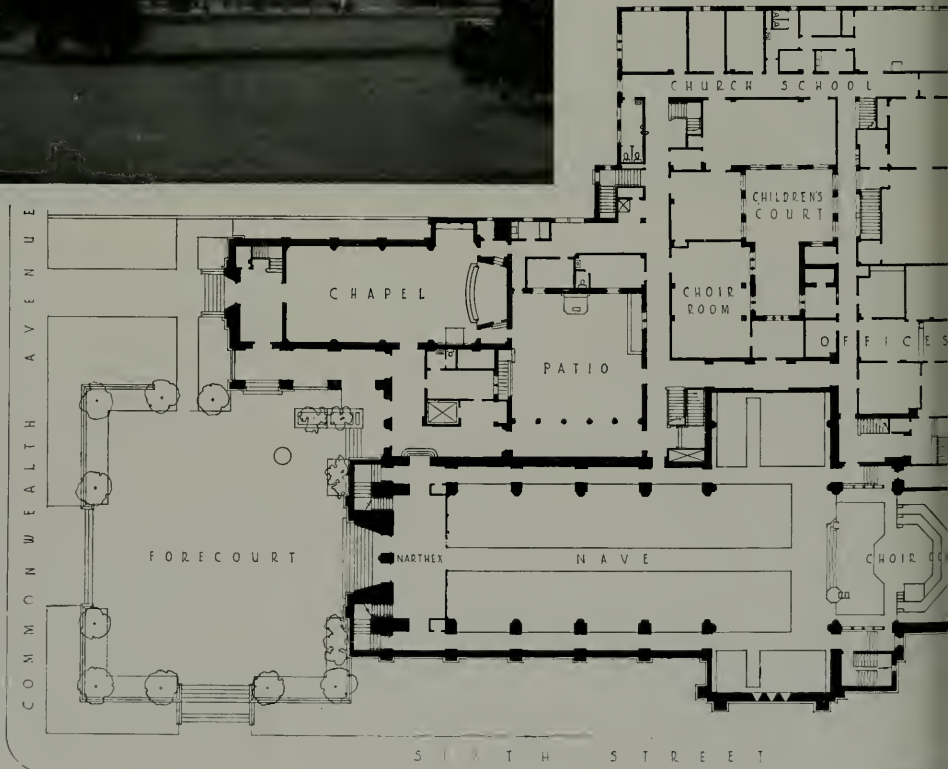

SECOND OR MAIN FLOOR PLAN, FIRST CONGREGATIONAL CHURCH OF LOS ANGELES



GARDEN VIEW, FIRST CONGREGATIONAL CHURCH
OF LOS ANGELES

ALLISON & ALLISON, ARCHITECTS



NAVE, LOOKING TOWARD THE CHANCEL, FIRST
CONGREGATIONAL CHURCH OF LOS ANGELES
ALLISON & ALLISON, ARCHITECTS

THE NEW FEDERAL PROGRAM FOR MULTI-FAMILY HOUSING

By C. A. WEST

THE problem of housing Exposition visitors next year, and relieving cramped conditions in rental housing facilities general throughout the populous centers of California, seems well on the way toward solution. A new financial program, designed to expedite the building of multi-family and group housing projects under the National Housing Act Amendments of 1938, now is available to builders and investors, and already has reaped a bountiful harvest of proposed projects.

The new plan permits the Federal Housing Administration to help finance, under insured mortgages, multiple-family dwellings, ranging from a modest duplex to a pretentious apartment house. The former regulations, still operative, provide for insured mortgages in amounts up to \$16,000 to finance dwellings up to four-family units. These may be written for as much as 80 percent of the appraised value of house and lot, and are repayable within 20 years on equal monthly payments.

The total annual maximum cost to the borrower on such a loan has been reduced to 5½ percent—five percent interest and one-half of one percent mutual mortgage insurance, both computed on declining balances. The service charge, which lending institutions were permitted to make under the old FHA regulations, has been eliminated.

For example, a \$16,000 insured mortgage on a single, duplex, or up to four-family dwelling, written for the maximum term of 20 years, now calls for payments of approximately \$139.64 a month. This includes principal and interest amounting to \$105.60; mutual mortgage insurance, \$6.57; taxes, on the average rate in California, \$24.80; and fire insurance approxi-

mately \$2.67. If the payments were increased to about \$160 a month, including taxes and fire insurance, the insured mortgage could be completely paid off within 15 years.

For dwellings larger than four-family units, the amended law provides a new program which is divided into two main parts. One is designed to promote construction of large scale projects covered by mortgages up to \$5,000,000 and the other to encourage building of smaller developments covered by mortgages ranging from \$16,000 to \$200,000.

An important feature of the new program is the provision for insuring mortgages not only on multi-family dwellings, but also upon developments consisting of single family houses. Under this provision it is possible for developers to obtain blanket mortgage financing, including funds advanced for construction, on groups of single family houses and then sell them on convenient payment terms, or rent them, as the builder sees fit.

The regulations will permit partial releases from the blanket mortgage as separate properties are sold.

The Federal Housing Administration will insure mortgages up to 80 percent of the appraised value of projects provided that, in the case of large scale developments constructed under Section 207 of the Housing Act, the amount of the mortgage may not exceed \$1350 per room, and in the case of the smaller developments financed under insured loans up to \$200,000 under Section 210, the mortgages may not exceed \$1150 per room.

The maximum interest rate which lending institutions are permitted to charge is 4½ percent on large scale developments under Section

207, and 5 percent on mortgages insured under Section 210. The mortgage insurance premium will be charged at the rate of one-half of one percent annually, computed on the outstanding balance of the mortgage.

The multi-family and group housing operations are being carried on separately from the small homes program, designed primarily for individual ownership. A separate insuring fund of \$1,000,000 has been set aside out of appraisal fees collected by the Federal Housing Administration during the past three years.

The Federal Housing Administration large scale housing program should not be confused with the slum clearance and government subsidy program of the United States Housing Authority. It is aimed primarily to promote the construction of housing facilities for wage earn-

ing and salaries families who, by preference or necessity, live in rented dwellings. Such families make up the great majority of the urban population, therefore they constitute the broadest market for new housing.

According to the 1930 census, approximately 56 percent of all urban families in the United States occupy rented quarters. The percentages range from a high of 78.6 percent in New York, to a low of 37.3 percent in Tacoma, Wash. In San Francisco, 117,129 families, or 65.6 percent, are tenants. Because of the relative breadth of the rental market, and the present security and economy of insured mortgage financing, the new FHA program should provide exceptional opportunities for sound investment and stimulate construction of large scale projects.



RESIDENCE OF MRS. BLISS, NEAR SANTA MARIA, CALIFORNIA
L. W. CRAWFORD, ARCHITECT

BUILDING RECOVERY DISCUSSED BY INSTITUTE DELEGATES

DEFINITE proposals for releasing the pent-up resources of the United States construction industries through a vast program of rebuilding were laid before the American Institute of Architects at its seventieth convention held in New Orleans the past month. Over 600 delegates from the Institute's seventy Chapters were in attendance, including a large representation from the Pacific Coast.

Committees representing the nation's architects, builders, materials manufacturers, and the allied arts, submitted studies of building costs, W. P. A. projects, housing and city planning, architectural education, etc., and representatives of the Federal Government outlined the important provisions of the new Housing Acts.

Many other subjects affecting architecture were dealt with at the convention, including allied arts, structural service, public information, preservation of historic buildings, registration laws, civic design, construction industry relations, professional organization of architects, and the development of the National Capital. More than a score of committee reports dealing with progress in these and other fields were submitted.

Under the auspices of the Institute's Committee on Housing, ten regional meetings mobilizing 12,000 architects to cooperate with the Government in stimulating small home building, slum clearance, and low cost housing have been held within the last month in addition to many local meetings. At these gatherings the possibilities of the new Federal Housing Act were explained and clinics held at which architects were made acquainted with all the details necessary in presenting projects for approval.

The Housing Committee, it was announced, has asked every regional and city planning commission in the United States to take steps to remove the barriers to the development of a slum clearance and a private industry building

program. The Housing Act, and the programs of the Federal Administration and the Federal Home Loan Bank Board will, it is declared, "greatly encourage both public and private housing without conflict."

The Institute's sessions were opened by Charles D. Maginnis of Boston, president, at 10 o'clock Tuesday morning in the Roosevelt Hotel, meeting headquarters. Gaston L. Porterie, Attorney General of Louisiana, welcomed the architects, after which Mr. Maginnis delivered the annual presidential address, and Edwin Bergstrom of Los Angeles submitted the Treasurer's report.

On Tuesday, a forum on architectural education was conducted by Dean William Emerson of Massachusetts Institute of Technology. Procedure for "preparation for practice" followed by the National Council of Architectural Registration Boards, the Association of Collegiate Schools of Architecture, and the Beaux Arts Institute of Design, in cooperation with the committee, were outlined.

Wednesday's sessions began with the report of the Committee on Housing by Walter R. McCornack of Cleveland, chairman of the Committee. The report described the major activities of the committee in cooperating closely with the government agencies in Washington and with national organizations engaged in the housing field.

Following the Housing report, the architects were addressed by A. C. Shire, acting director of the Technical Division of the U. S. Housing Authority; Miles Lanier Colean, deputy administrator of the Federal Housing Administration; Ormond E. Loomis, assistant to the chairman of the Federal Home Loan Bank Board; and Coleman Woodbury, director of the National Association of Housing officials.

A joint seminar on housing and luncheon of the Institute and the Producers' Council was held Wednesday with E. O. Shreve, vice presi-

dent of the General Electric Company, the principal speaker. Russell G. Creviston of the Crane Company, Chicago, president of the Council, presided.

Thursday afternoon the architects paid a visit to "Oak Valley," a typical Louisiana plantation house on the Mississippi River. In the evening, the School of Architecture of Tulane University, acted as host at a reception and an exhibition of the work of Henry Hobson Richardson in the galleries of the Newcomb School of Art. Henry R. Hitchcock, Jr., spoke entertainingly on the life and work of Richardson.

Frederick H. Meyer of San Francisco, vice president of the Institute, presided at the concluding business session on Friday morning. Action on the report of the Committee on Resolutions followed an open forum discussion and consideration of revision of Institute documents.

INSTITUTE MEDAL AWARDS

The Gold Medal of the American Institute of Architects, the highest honor bestowed by the architectural profession of this country, was awarded to Paul Philippe Cret of Philadelphia.

Carl Milles, Swedish architectural sculptor, received the Fine Arts Medal. The Craftsmanship Medal was given to Joseph H. Dulles Allen of Philadelphia, founder and president of the Enfield Pottery and Tile Works.

Rufus Cutler Dawes of Chicago, who was president of the Century of Progress Exposition, was elected an honorary member of the Institute. Francis Lorne of London, known for his design of London apartment buildings, and Louis Madeline of Paris, architect of the Grand Palais, were made honorary corresponding members.

Mr. Cret, who is honored for "most distinguished service to the architectural profession" has been professor of architecture at the University of Pennsylvania for the past thirty-five years and in independent practice for the past thirty years. His professional work, comprising a great number of federal buildings, libraries, museums, schools, apartment houses, hotels, bridges, monuments, and city plans, is said to exhibit "so superb a conception of fitness and

beauty that few architects of any time could match him."

Honors previously bestowed on Mr. Cret include the Paris Prize, 1896; Rougevin Prize, 1901; Grand Medal of Emulation of the Ecole des Beaux Arts, Paris, 1901; Gold Medal of the Salon des Champs Elysees, Paris, 1903; Medal of Honor of Architectural League of New York; the Bok Prize in Philadelphia, 1931; and the distinguished award of the Washington Society of Architects.

Mr. Cret is 61 years old and a native of Lyon, France.

Mr. Milles, winner of the Fine Arts Medal, was cited as "one of the greatest living sculptors, who has enriched many of our public buildings and who is an undoubted force in education as well." He is an honorary member of the Institute and of the Mark Twain Society in New York. He is also a member of the Architects League of New York and Vienna, and of the Swedish Academy of Science.

He was born in Sweden, June 23, 1875, and was educated in Stockholm and Paris. He is Doctor of Honor of Bethany College, Lindsborg, Kan. He was formerly professor of art in Stockholm and he now teaches for three months of every year at Cranbrook University, Bloomfield Hills, Mich. In 1932 he became an American citizen.

In 1900 Mr. Milles received a silver medal for work he entered in a Paris exhibition. He won a gold medal in a Munich art show in 1907. He has also exhibited in Buenos Aires, Copenhagen, Dresden, London, Goteborg, Vienna, New York, Brooklyn, and St. Louis.

Mr. Allen was awarded the Craftsmanship Medal for his "pioneer work in the field of ceramics," according to the citation. In 1906 he founded the Enfield Pottery and Tile Works in Enfield, Pa., where for the preceding six years he had been proprietor and manager of a stock farm. He has lectured on ceramics to architectural students in the University of Pennsylvania and has contributed articles on color, ceramics, and craftsmanship to architectural magazines. He is constantly exploring new fields in ceramics.



RESIDENCE OF MR. AND MRS. A. I. LAUNDER, SEATTLE, WASHINGTON

EXTRA! – CLIENT AND ARCHITECT HAVE LIKE IDEAS FOR HOME

By Joshua H. Vogel, Architect

ONE day a fellow member of the Seattle Engineer's Club asked me to have lunch with him. After coffee was served he lighted his pipe and said, "I want to build a house, and here is the house I must have." Immediately I had visions of the average client with preconceived notions of a jumble of unrelated ideas. But as my friend talked on, I began to realize that here was someone different, the client of the Architect's dreams. Yes, my client had preconceived ideas, but they were practical.

His home must first of all be a thing of the simplest beauty. It might face the west where in the golden sunsets ships sail by, bearing gold from Alaska and priceless treasures from the Orient, with a vista of the rugged Olympics across the beautiful blue waters of Puget Sound; or it might face the east where, beyond the sapphire waters of Lake Washington, the lights of villages twinkle and farther on the roll-

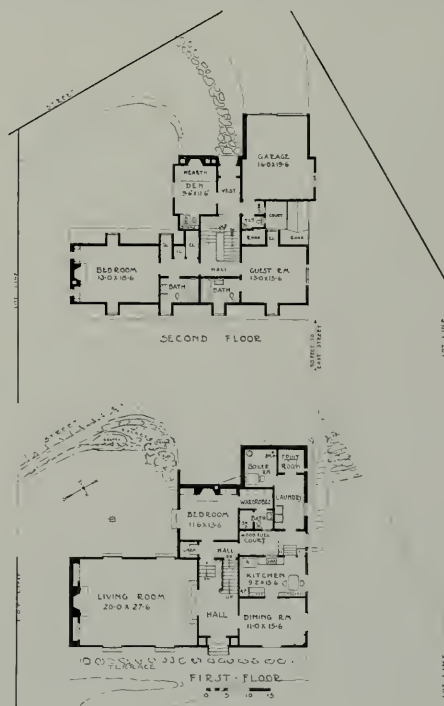

PLANS, RESIDENCE OF MR. AND MRS. A. I. LAUNDER, SEATTLE, WASHINGTON
Joshua H. Vogel, Architect



RESIDENCE OF MR. AND MRS. A. I. LAUNDER, SEATTLE, WASHINGTON
 JOSHUA H. VOGEL, ARCHITECT



INTERIOR, RESIDENCE OF MR. AND MRS.
 A. I. LAUNDER, SEATTLE, WASHINGTON
 Joshua H. Vogel, Architect

ing fir-studded foothills rise to the snow-capped peaks of the mighty Cascades. The house must be livable, with a large living room for evenings of music. A quiet library for reading and study must be entirely separated from living and sleeping quarters, yet handy to the entrance for short callers or for business. Each room where practicable must have its fireplace. There must be no back, no front, but rather solid, yet simple, beauty from all angles, and no sham. There was the problem and the challenge, and here is the result:

Together we searched the hundred miles of shorelines of lakes, bay and sound, and the slopes of the seven hills upon which our beautiful city is built, both by day and by night, in sunshine and rain, in winter and spring and into the summer. To choose from among literally thousands of panoramas is no easy task. Finally, as the days lengthened, we turned more and more to the rolling slopes above Lake Washington. Here the sun rose above the silhouette of the Cascades. In midday and afternoon the reflection was from lake to mountains, rather

than from water back to our eyes as from the western view over Puget Sound. The Sunset was reflected from the mountains in dimming shades of rose and purple long after the day was done.

Ideal Site

The choice of site then narrowed down to Windermere, a beautiful restricted suburb with all utilities underground and all improvements in and paid for. Further, this area lies but two miles distant from the University of Washington Campus, three miles from the University shopping district, and seven miles from the city center over a main arterial. Of the sites, averaging 100 by 200 feet in size, one was selected with the client's specifications in mind. This lot slopes through from a paved street on the West to a slightly diagonally curving gravelled road a little to the South of East. Here, indeed, was the site for our home: From the West we may enter the garage from the pavement. Through a splayed arch in a wall of white sandstone we enter a small hall and on this level, here convenient to garage and door, we have a library, or den, with cathedral ceiling, one end forming a broken marble fireplace and hearth with provision for book cases. On the opposite side of the hall is coat closet and lavatory, the coat closet forming an entry into the garage.

Approaching the house from the East we walk up a gently sloping gravelled path, through a hundred feet square of lawn hedged and made private by a birch copse, southern magnolias, a row of apple trees, and sweet briar roses. Here we see a Colonial type four-dormer house with a white sandstone end-wall, which caused a Massachusetts friend of the owner to exclaim—"This is West Newbury."

The stone end-wall faces a little to the West of South and protects the living room alike from the heat of the summer afternoon sun and the prevailing Southwest rainy winds of January and February.

Interior Described

Entering the main hall we have the large living room on the left panelled and canvassed and painted a soft gray green. Opposite the entry is an onyx fireplace and hearth, with co-

lonial over-mantle. In the right wall of the living room are two pairs of French doors leading to a secluded grass covered court with rockery. Through these doors we see a rockery with a trickle of water running over a large flat stone to a cavern pool from the backs and sides of which reach long fronts of maidenhair ferns transplanted from the mountains across the lake. On the opposite side of the living room is another pair of French doors, through which we see the lake and mountains. From the right side of the hall we enter the dining room with French windows in the East and North. Beyond is the kitchen with French windows opening on the North and casements opening onto an open air service court. From these North, or rather East of North, French windows of dining room and kitchen may be seen another vista of the lake and mountains beyond the headlands of Sand Point to the North.

Coming back to the interesting irregularly ceilinged main hall the Colonial stairway ascends ten steps to the West entry, before described, then turns and goes upstairs to two dormered bedrooms, each with a bath, and one with dressing room and fireplace. Below the library and West hall is a secluded bedroom, with fireplace and small dressing room and built-in shower bath. On the South side of the room are French doors leading to the secluded garden nook and pool we viewed from the living room. A small hallway leads from this room to the Service Court where fuel is stored, deliveries made, and another access is had to laundry and kitchen and to the collie's kennel.

The Design

Having the general features of the house in mind, I should like to discuss briefly some of the fundamentals of the design. First, the materials at hand were utilized—white Wilkeson sandstone from the Cascades, Douglas fir lumber and cedar siding from the green foothills across the lake. Marble for the fireplaces was selected from remnants on hand in the marble shops. Oak was used for flooring even in kitchen and baths, this material considered by both my client and myself to be more sanitary and easily cared for than tile. Lighting fixtures and hardware are

(Please turn to Page 51)

HOME IN SOUTHERN CALIFORNIA by H. ROY KELLEY



RESIDENCE OF MR. AND MRS. JOHN HOLMAN, SAN MARINO, CALIFORNIA

Plans indicate a well studied ground floor, with family living quarters nicely separated from service wing, servants' quarters and garage. Family sleeping rooms all on second floor.

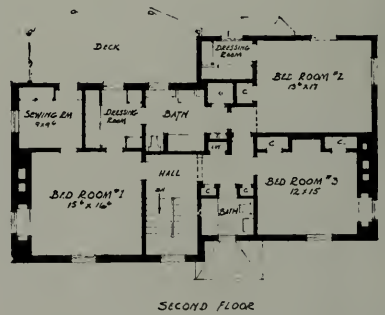



DETAIL OF ENTRANCE, RESIDENCE FOR MR. AND MRS. JOHN HOLMAN,
SAN MARINO, CALIFORNIA



PORCH, RESIDENCE FOR MR. AND MRS. JOHN HOLMAN,
SAN MARINO, CALIFORNIA



ARCHIBALD MEMORIAL PULPIT, FIRST CONGREGATIONAL CHURCH
OF LOS ANGELES (Other photos Pages 32, 33, 34)
ALLISON & ALLISON, ARCHITECTS

FAILURE OF THROUGH TRUSS BRIDGES OF NARROW ROADWAY WIDTH

By F. W. Panhorst

DURING recent years there have been many cases where heavy vehicles have crashed into bridges on the California State Highway System, resulting in the complete collapse of the spans or otherwise causing failure.

What would happen if a huge truck, weighing 60,000 lbs. going at the rate of 30 miles per hour, crashed into a supporting member of an elevated water tank?

The result can easily be imagined. Obviously the water tank is designed only to sustain a vertical load and the comparatively small horizontal force exerted by wind pressures. The

same is true of a bridge. In other words, no matter how sturdily a bridge is constructed, regardless of the fact that it can carry safely the heavy loads which represent a vertical force placed upon the structure, it does not follow that the same bridge can withstand an equal or greater force in a horizontal direction.

Many of the bridges on the California State Highway System are of the through truss type, in which the supporting members extend above the deck of the structure. The more serious accidents have occurred in connection with through truss bridges of narrow roadway width.



*Illustrations
Courtesy of
California
Highways and
Public Works*

LEFT—SACRAMENTO RIVER BRIDGE AT RED BLUFF COLLAPSES. TRUCKS AND STEEL FRAMEWORK ARE SHOWN IN RIVER. RIGHT—TOWER ON SAN BENITO RIVER BRIDGE NEAR HOLLISTER DAMAGED BY TRUCK.



OLD BRIDGES ARE MENACE

ABOVE—GASOLINE TANK TRUCK CRASHES PIT RIVER BRIDGE, NEAR DUNSMUIR, CALIFORNIA, AND BURNS.

CENTER—OVERLOADED TRUCK CAUSES COLLAPSE OF SAN JOAQUIN RIVER BRIDGE IN MERCED COUNTY, CALIFORNIA.

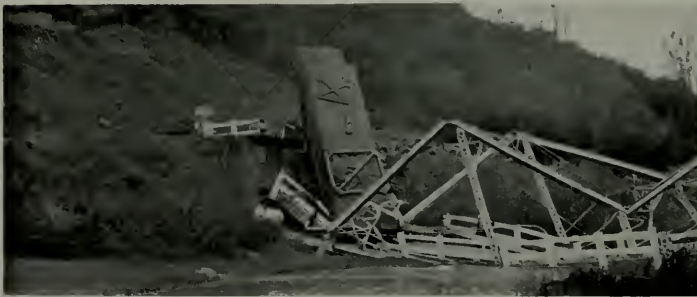

LOWER—TRUSS SPAN OVER WOODS CREEK ON THE OAK FLAT ROAD DEMOLISHED BY TRUCK.

Unless proper precautions are taken by vehicles when crossing such structures, one of the side members may be struck, causing the complete collapse of the span. The seriousness of such an occurrence can readily be seen for it may not only cause loss of life and property damage, but in all probability may block all traffic until the span can be reconstructed.

On October 20, 1937, a truss span over Woods Creek on the Oak Flat Road was de-

molished by a truck carrying two large pontoons to be used in the construction of a gold dredger. The truss was in good condition and strong enough to carry safely legal loads under normal circumstances. The evidence establishes the fact that an end post member of the truss was struck by an overhanging pontoon and knocked from its supports. The result was that the complete span fell into the creek with the truck on it as shown in the accompanying photograph.

A short time before, on September 23, 1937, the westerly arm of the swing span of the San Joaquin River Bridge on the Pacheco Pass Road collapsed under a combination of excess loads, excessive speed and the striking of some of its truss members. This bridge had been posted for reduced load and speed limit. The collapsed span with the trucks on it is shown in the photograph.

On December 2, 1937, a heavy load requiring extra high clearance tore out the portal framing and damaged the end post of a timber truss bridge over Yager Creek on the Trinity Road between Red Bluff and Fortuna. This span had been strengthened temporarily by placing supports under the center of each beam. It was only for this reason that the trusses did not collapse. It was possible in this case to place supplementary bents under the floor beams and maintain traffic over the bridge, subject, however, to the probability of these temporary supports being washed out during any flood that might occur during the winter.

The collapse of the Sacramento River Bridge at Red Bluff in October, 1936, was described in the newspapers and technical journals at the time it occurred, as was also the failure of the timber arch span over Rock Creek in Mendocino County, which occurred April 21, 1937.

While the failure of the Rock Creek Bridge was discovered before any damage was done

to vehicles, it was necessary to stop all heavy traffic for several weeks while a temporary structure was being built across the canyon. This materially affected the hauling of supplies into the communities along the Redwood Highway.

Twice within six weeks, heavy trucks got out of control on the Pit River Bridge, 14 miles north of Redding on the Pacific Highway. In both cases large gasoline trucks were wrecked and caught fire on the bridge causing death or serious injury to the drivers.

The bridge, being of concrete, was not seriously damaged, although it is quite likely that its service life may be impaired. If it had been one of the many light steel structures still in use on the State Highway System it would undoubtedly have been demolished. One of the photographs shows the truck after it had burned on the bridge and also shows a considerable length of concrete handrail which was knocked out. The holes in the end of the tank were made by the bullets of traffic officers in an effort to allow the gasoline to escape and prevent a serious explosion.

Editor's Note—In Southern California many highway and city bridges were washed away by the hard rains in February and early March. The need for building stronger bridges was apparent and doubtless city, county and state engineers will design our future bridges with the increased safety factors in mind.



YAGER CREEK BRIDGE IN HUMBOLDT COUNTY, CALIFORNIA. NOTE BROKEN END POST.

WORLD'S FAIR BUILDERS — T. F. PFLUEGER

“‘God Bless Us All,’
Said Tiny Tim” ... (Dickens)

By MARK DANIELS

TIM rolled up his sleeves an inch or two higher and grinned over a table littered with bas-reliefs, terrazzo samples and plaster models. “The artists have always had a tough time. I’m trying to get more of their work into my jobs.” He needn’t have mentioned the point, for all San Francisco knows of his five years’ service as president of the San Francisco Art Association.

Of course, when a man has headed a civic organization such as the Art Association and the Parilia for years, we get used to him so much that we soon forget to be grateful for our daily blessings. So Tim pops his head over our narrow horizons every now and then in varying new capacities, such as chairman of the board of consulting architects of the San Francisco-Oakland Bay Bridge, and member of the architectural commission of the 1939 Golden Gate International Exposition.

About the time that our wonder at the beauty of the Telephone Building subsides, and we begin to forget him again, Tim Pflueger tosses 450 Sutter in our eyes, and before we can forget that entirely, which is impossible, along comes the Federal Building at the Golden Gate International Exposition. Mr. Pflueger has been doing this for some time, periodically giving birth to such buildings as the Metropolitan Life, the Paramount Theater in Oakland, and the San Francisco Stock Exchange, with no apparent labor pains, and no other midwife than his associate, Jimmy Miller.

For awhile it looked as if Mr. Pflueger was entered upon a long and fixed career. With the George Washington High School, the Roosevelt High and the Jefferson School, there arose a sort of feeling that he might become the architect of all “president” schools. After all, why not? There are only twenty-nine left to go. But the chain was broken when Tim took on the job of the San Francisco Junior College. There still is the chance, however, that the name might be changed to Wilson.



TIMOTHY F. PFLUEGER, ARCHITECT

Tim does a great deal of work for his friends. For eight years he has been chairman of the Farm Committee of the Family Club, where he spends much of his leisure time working. Now he is spending more of that same leisure remodeling the city building for the Family. Some might say that the jobs he turned out for Bal Tabarin and the Circus room at the Fairmont were pastimes. Perhaps so for Timothy L. Pflueger, but for most architects they are a lot of work.

If you ask Tim what are his hobbies he will probably tell you they are work and flying. He does, nevertheless, give a lot of time to the helping of artists and his two favorite clubs, the Bohemian and the Family Clubs.

Tim Pflueger's great rise in architecture has

CALIFORNIA NEEDS BETTER FLOOD CONTROL

By EDWARD HYATT, State Engineer

THE floods of the past winter exceeded those of record in many portions of the State, doing damage estimated at eighty million dollars, and causing the loss of over one hundred and fifty lives. These floods can be considered in three phases—first, the very heavy but short storm of early December in Northern and Central California; second, the continued high water of February and March in the same area; and third, the destructive flood of the first week of March in Southern California.

Total seasonal rainfall in Sacramento on December 1, 1938, was 3.56 inches, just slightly over normal, and in Northern California generally the season appeared to be similar to 1935 or 1928. However, on Thursday, December 9, the United States Weather Bureau charted "a disturbance of much intensity over the Pacific about 600 miles off the California coast," apparently moving toward the coast.

come with what might be called his "logical, horse-sense modern approach" to every suitable problem. This hallmark of Pflueger will be evident all over Treasure Island next year, for great quantities of the Western World's Fair buildings are growing under Tim's hand.

There's the Federal Building as mentioned, there's the Court of Pacifica—through which two-thirds of the visiting millions will thunder for at least ten steps before they pause to gape and gasp, as they come into the Fair from the ferry boats—and there's the widespread California State group.

These three big jobs, at least, Tim Pflueger will toss in our eyes on Treasure Island and he will probably tell you they were fun, too. World's Fair architecture, here today and gone tomorrow, properly ranks as a hobby, but all of Tim's work is a hobby and all of his working world is fun. To relax, he goes down to the office, and that's the way it is nice to be.

On December 10th the storm broke and lasted through the 13th. Rainfall for the first two days reached eighteen inches at points on the Feather and Yuba rivers watersheds and was above ten inches at many Sierra stations. The resulting flood stages in the rivers were very high, in many places the highest on record. A typical example is the Tuolumne River, the crest flow of which was reported at 77,000 second-feet as compared to the previous high of 60,000 second-feet in 1911. In the Sacramento watershed, the peak flow was higher than anything recorded since 1928, and in some cases 1909 or earlier. On the Sacramento River at Red Bluff, where record has been maintained since 1902, the crest was over a foot higher than any previous record. The Feather River was higher than at any time since 1907. In Sonoma County, the Russian River is said by the older inhabitants to have been higher than at any time since 1862. In the San Joaquin Valley, the Kings and San Joaquin rivers are said to have been higher than at any time since 1888.

A large amount of damage resulted from these floods. In the mountain areas this consisted chiefly of damages to roads and bridges and flooding of developments along the stream channels. The towns of Alturas, Chester, and Downieville suffered serious damage. The lower portions of the Yosemite Valley were flooded, and the all year highway and Yosemite Valley Railroad materially damaged.

In the Sacramento Valley, the levee system, designed to protect the cities and agricultural lands from floods, failed at several points in its upper reaches. The Sacramento River overflowed its banks below Red Bluff and flooded the towns of Gerber and Tehama and lands in Tehama and Butte counties. Serious breaks occurred in the levees along the Sacramento

Synopsis of address before San Francisco Section, American Society of Civil Engineers, April 19

River in Glenn and Colusa counties and large agricultural areas were flooded. The Feather River broke through the levee at Hamilton Bend below Oroville and sent a large flow westerly across developed farm lands into Butte Basin, north of the Sutter Buttes, flooding settled areas, including the city of Biggs. Serious breaks also occurred north and south of Marysville, damaging large acreage of developed farm land. From Knights Landing south to the bay the levee system held. Opposite Sacramento the maximum flow was reduced considerably by storage in the upstream flooded areas.

In the north coast area heavy damages were suffered in Sonoma, Mendocino, Humboldt and Lake counties. The Russian River flooded the resort areas in Sonoma County and farm lands in the vicinity of Healdsburg. In Mendocino County the damage was chiefly to roads and bridges and in Lake and Humboldt counties to agricultural development.

In the San Joaquin Valley damages were principally confined to the delta areas of the Kings and Kaweah rivers and the lower lying lands along the San Joaquin River. Reservoirs on the Mokelumne, Stanislaus, Tuolumne, and Merced rivers prevented damage on these streams below the respective reservoirs. It should be pointed out that but for the effect of these reservoirs, large damage would have been inevitable in the lower valleys and delta of the San Joaquin River.

This flood caused damage estimated to exceed fourteen million dollars. There were many levee breaks in the Sacramento Valley, both within the Sacramento Flood Control Project and on the river and tributaries above the project proper. Lack of proper maintenance was a prime cause of these levee failures. A vast amount of debris was swept from the mountains into the stream channels in the valleys causing overflows, channel changes and serious agricultural damage. The repair of damage under local, state and Federal auspices started immediately after the flood had subsided and most of the levee breaks in the Sacramento Valley were closed.

During the remainder of December 1937,

and in January 1938, there were no severe rainstorms but in February a succession of storms raised the streams to dangerous heights in practically all of Northern and Central California. No accurate data are as yet available on the rainfall. Snowfall figures for the season to date at Soda Springs, elevation 7,000 feet, follow: Maximum peak at any one time 230 inches; total fall 802 inches; fall during February 365 inches, the maximum recorded in a single month, a previous maximum having been 296 inches in April 1880. (Figures from Southern Pacific Company.) As of April 1st, the water content of the heavy snowpack above 6000 feet is between 40 and 50 per cent. There are 17,000 square miles in the snow fields of the western Sierra slope. The all-time high record for measured water content was recorded this year at the Mt. Lassen snow course, where the results show 152 inches of water content in a snow cover 282 inches deep.

At places in the Sacramento Valley the peak flows of February equalled those of December, but on account of vigilant maintenance there were few if any breaks. The Sacramento Flood Control Project functioned satisfactorily at all times during February and March. During this period the Feather, Yuba and American rivers did not reach dangerous stages. Many levee breaks and much damage occurred on the San Joaquin River from Mendota to Stockton; in the San Joaquin Delta, where several islands were flooded; on Dry Creek near Fresno, which flooded a suburban area; at Watsonville, where the town was twice flooded; and at many other points. The Tulare Lake Basin area is largely under water at the present time and with the expected snow runoff the greater part of the Lake will probably be inundated this spring.

The Southern California flood of February 28 to March 5, was somewhat similar to the December storm in Northern California in that it was sudden, short, but of extreme intensity. No accurate rainfall data are available, although it is reported that there was an inch an hour for eighteen hours at one station. San Bernardino, Orange, and Los Angeles counties were the hardest hit, with lesser damage in Riverside, San Diego, Ventura, and Santa Bar-

para counties. Peak flows in many streams were more than twice any previous record.

In the four counties—Los Angeles, Orange, Riverside, and San Bernardino, this storm and the resulting flood peaks were of unprecedented magnitude. Total damage in Southern California is variously estimated at from fifty to eighty million dollars from this storm alone, this figure being much larger than that for the remainder of the State.

In the State generally, but in Southern California particularly, it has been demonstrated that zoning restrictions should be enforced in flood channels and on exposed debris cones, until such time as adequate flood control works are constructed.

RESIDENCE IN SEATTLE, WASHINGTON

(Concluded from Page 41)

of solid brass, and each piece was selected by the owner and approved by the architect before the contract was let. Every item of material and construction shows honesty of purpose or "art expressing function." View windows as such were not used and the guest in the house is not constrained to say: "What a magnificent view," and then close Venetian blinds to keep out excess light. Beautiful vistas are to be seen from all openings, but the house was not planned to just spot a frame for one scene, but rather to contemplate them leisurely as one would study a painting.

* * *

A Satisfied Client

The writer asked Mrs. Launder to pen a line telling what she thinks of her home after three years of living in it. Here is her answer: "Each morning as the songs of the birds waken me I look into the hills and am thankful for the beauties of this wonderland. As I come down the stairs I see through the living room arch and window a picture of the majesty of creation in beautiful snowcapped Mount Rainier. As for the arrangement, proportions and detail of the house itself, were I to start all over again I cannot think of a single item I would give permission to change."

ADOBE CONSTRUCTION

(FHA Requirements)

1. General provisions governing masonry walls shall apply to adobe brick walls, except as otherwise herein provided.

2. Adobe walls shall be constructed of approved units in conformity with detailed designs and under competent supervision.

3. Adobe brick in exterior walls shall be rendered water-resisting by mixing asphalt emulsion with the aggregate. Brick shall be thoroughly cured.

4. Brick samples taken from the job shall be tested in compression and shear and for absorption, by an approved engineering laboratory. Such tests shall be at the sole expense of the applicant, and copies of reports shall be sent direct to the San Francisco Insuring Office by the testing laboratory.

5. Adobe brick shall show an ultimate strength of at least 350 pounds per square inch in compression and 40 pounds per square inch in shear. Designed working stresses shall not exceed the following in pounds per square inch:

Compression, 35; Shear, 4 pounds; Tension, zero.

6. Adobe structures shall not exceed 2 stories in height. Height of adobe walls shall not exceed 10 times their thickness and shall not be less than the following thickness:

Exterior: Top story, 18 inches; lower story, 2 feet.

Interior: Top story, 12 inches; lower story, 18 inches.

7. Mortar for adobe walls may be similar in composition to the adobe brick. Time shall be allowed in laying up for equalizing of settlement and drying of mortar. Laying shall be done in uniform stages throughout the structure.

8. Footings for adobe walls shall be specifically designed and proportioned with relation to actual bearing capacity of the soil at the site. Weight of walls shall be assumed as 100 pounds per cubic foot. Footings shall be reinforced with not less than two $\frac{3}{8}$ -inch round bars.

9. Foundation walls shall be of concrete to a height of at least 6 inches above finished grade and thick enough to provide full bearing for the wall plus at least a 3-inch bearing for first floor slab or redwood sill bolted 6 feet o. c. for joists.

10. Adobe walls shall be positively bonded to concrete bearing surfaces and shall be capped at each story height with concrete at least 6 inches thick, the full width of the wall, reinforced with at least two $\frac{3}{8}$ -inch round bars embedded at least 3 inches in the concrete. Walls shall be allowed to settle before caps are placed.

11. Plates for fastening roof and ceiling construction to wall caps shall be bolted to the concrete cap not more than four feet on centers with $\frac{1}{2}$ inch by 8 inch bolts.

12. Interior partitions of stud construction may be

used. Such, if bearing partitions, must be on continuous concrete foundations. All stud partitions in contact with adobe walls shall be anchored thereto with not less than three perforated galvanized strap anchors with hooked ends embedded in the adobe wall at least ten inches.

13. All timber and woodwork in contact with adobe construction or concrete below the first floor shall be protected as required under "Termite Prevention," Paragraph 1 (b). All other wood construction and wood work may be brush or spray-treated.

14. All lintels exceeding a clear span of 4 feet shall be of steel or reinforced concrete.

15. There shall be no pipes or chases in walls, except for reinforcing steel unless walls are thickened accordingly.

16. One-story dwellings of simple straightforward design and generally rectangular plan, not exceeding 800 square feet of floor area inside of the exterior walls may be built without subjection to structural analysis provided the following additional requirements are met:

- (a) The aggregate widths of openings in each length of wall shall not exceed 35% of the length of the wall and no pier nor section of wall less than 3 feet long between openings shall be considered as wall section. Niches and recesses in walls shall be considered as openings.
- (b) The height of any adobe brick wall above foundation shall not exceed 9 feet. Gable ends shall be wood frame construction or may be of adobe not less than 12 inches thick capped with concrete and reinforced vertically as provided for walls in Paragraphs (d) and (e) following.
- (c) The length of any wall between abutting cross walls shall not exceed 25 lineal feet unless such wall is given satisfactory additional support by buttresses or thickening of the wall.
- (d) Each adobe wall shall be reinforced with $\frac{3}{8}$ -inch round steel bars running continuously from footing to wall cap, placed at each corner, at each side of each window and door opening and not over six feet apart on each side of the wall with bars staggered on opposite sides of wall. Ends of bars shall be anchored and cast into footing and wall cap.
- (e) Concrete wall cap shall be 8 inches thick full width of wall, and reinforced with two $\frac{3}{8}$ -inch round steel bars 1 inch from the top surface and two similar bars 1 inch from the bottom surface. Bars shall be laid and tied as called for under Paragraph 10 above.
- (f) Roof rafters or ceiling joists shall be solidly diagonally sheathed.
- (g) Roof rafters and ceiling joists shall be securely spiked to wall plate, and where possible spiked together.

BOOK REVIEWS

GARDENING INDOORS: By F. F. Rockwell and Esther C. Grayson; The Macmillan Co., New York City, N. Y. Price \$2.50.

There is very aptly pointed out in this interesting volume several subjects concerning a neglected phase of gardening—that of growing plants and flowers within the house.

To those who are interested in following a delightful hobby this book gives in detail the necessary procedures in order to create an indoor garden of the right proportions, correct plants, their care, propagation and so forth. This is indeed a book well worth the while of every person who loves plants and flowers.

THE GARDEN OF PINKS: By L. H. Bailey; The Macmillan Co., New York City, N. Y. Price \$3.00.

This is an excellent book on a fascinating flower and its care, propagation and growth. There is contained in the chapters useful knowledge on insects and diseases to which pinks fall a prey, and the manner of successfully combating these evils. Fully illustrated with some plates in color, this book makes a delightful adjunct to the gardening book shelf.

PLANNING AND PLANTING YOUR OWN PLACE: By Louis Van De Boe; The Macmillan Co., New York City, N. Y. Price \$4.50.

A book every home owner will find an inspiration and help. When it comes to planning a garden and the expense of laying out the ground, selecting the proper plants, segregating them or mixing them according to balance, color schemes and so forth, then he who has this book will be thankful and is not likely to regret his purchase. Cost figures are given, types of land discussed, soils analyzed, not chemically perhaps, but from a practical viewpoint. Well illustrated with photographs, drawings, and diagrams, this volume can be of great assistance to the landscape architect as well as the home gardener.

LIGHT, PHOTOMETRY, AND ILLUMINATING ENGINEERING: By William Barrows; McGraw-Hill Book Co., 330 West 42nd Street, New York City, N. Y. Price: \$4.00.

A very fine, clear and well illustrated book dealing with an important subject in every day life. This book should be of especial value to the lighting engineer, who is keeping abreast of these modern times; likewise the architect can find much of value and interest here and is serving the better interests of his clients when his working library contains such books for ready reference.

AIR CONDITIONING—FURNACES AND UNIT HEATERS: By J. Ralph Dalzell; American Technical Society, Drexel Avenue at 58th Street, Chicago, Ill. Price: \$3.00.

An excellent book dealing with a subject of importance to all home and building owners, architects and contractors. Heating engineers will find here a worthwhile addition to their shelves. The book covers a wide field and is well illustrated.

With the Architects

PLACERVILLE RESIDENCE

Harry J. Devine, of Sacramento, has completed drawings for a \$15,000 residence to be built at Placerville for Dr. A. A. McKinnon, 300 Main Street, Placerville. Contract has been let by the same architect for a County Branch Library Building at Carmichael. Mr. Devine is preparing preliminary drawings for an addition to the Grass Valley High School, estimated to cost \$100,000.

NEW BOTTLING PLANT

Plans are being prepared by W. D. Peugh, architect, 333 Montgomery Street, San Francisco, for a one-story addition to the present rectifying and bottling plant of the Schenley Products Company at Battery and Vallejo Streets, San Francisco. Besides adding one-story to the present structure, the building program includes a second two-story mill-type building to be sprinkler-equipped and fireproofed throughout.

OAKDALE GRAMMAR SCHOOL

Frank V. Mayo and Eric Johnson, architects, 931 North El Dorado Street, Stockton, have been commissioned to prepare plans for a group of school buildings for the Oakdale Grammar School District in Oakdale, Stanislaus County. There will be seventeen class rooms and an auditorium. A PWA grant for \$200,000 has been requested.

STORES AND OFFICES

A four-story Class C steel frame and concrete store and office building will be constructed at Fourth and "B" Streets, San Rafael, for Jacob Albert, from plans by Carl F. Gromme, Freitas Building, San Rafael. There will be five stores and thirty-six offices. Construction will be handled by Leibert & Trobock, Albert Building, San Rafael.

HIGH SCHOOL SHOPS

W. G. Corlett and Henry H. Gutterson, associated, have completed drawings and contracts are being let for new shop buildings at Milvia and Kittredge Streets, Berkeley, for the Berkeley High School. Construction is to be reinforced concrete and composition roof. Freight elevators are included in the equipment.

CHURCH ALTERATIONS

Theodore G. Ruegg, architect, 251 Kearny Street, San Francisco, is preparing working drawings for remodeling the Church of Jesus Christ of the Latter Day Saints on Thermal Street, near 98th Avenue, Oakland; also for the same denomination a new edifice at Pacific Grove to cost \$6,500.

BERKELEY RESIDENCE

Plans have been completed by John B. Anthony, 462 Elwood Street, Oakland, for a two-story frame and stucco residence on Euclid Avenue, Oakland, for Frank Carroll.

Another Berkeley residence is being designed by B. Reede Hardman, 2068 Allston Way, Berkeley, on Cragmont Avenue.

PAROCHIAL SCHOOL ADDITION

St. Joseph's Parish, Alameda, has started construction of a two-story, four-room addition to the Boys' Parochial High School, from plans by Henry A. Minton, architect, 525 Market Street, San Francisco.

RAYMOND DeSANNO BUSY

New work in the office of Raymond DeSanno, architect, 2584 Milvia Street, Berkeley, includes four three-room apartments for Wallace Snellgrove in Martinez, and a six-room residence in Richmond for Herbert Johnson.

MEDICO-DENTAL BUILDING

Plans are being completed by C. A. Caulkins, Jr., Rosenberg Building, Santa Rosa, for a two-story frame and stucco medico and dental building at 10th and "B" Streets, Santa Rosa, for Dr. R. E. Hamlin.

SARATOGA RESIDENCE

Birge M. & David Clark, architects, 310 University Avenue, Palo Alto, have completed plans for a \$16,000 residence to be built in Saratoga for Jay Murray. House will be one-story frame and stucco and will contain seven rooms, three baths and double garage.

MORTUARY BUILDING

Plans have been completed and construction started for a two-story reinforced concrete mortuary in Hayward for Sorenson Bros. Henry C. Smith, San Francisco, is the architect.

THEATER ALTERATIONS

A. A. Cantin, architect, 64 Pine Street, San Francisco, has awarded contract for alterations to the Golden Gate Theater at 5812 San Pablo Avenue, Oakland. Improvements will cost under \$10,000.

APARTMENT HOUSE ALTERATIONS

Alterations to the apartment building at 1055 California Street, San Francisco, will cost about \$7,500 from plans by Architect Lewis P. Hobart, 525 Market Street, San Francisco. Mrs. Rudolph Schillings is the owner.

LANDSCAPE ARCHITECTS

San Francisco Chapter, A. S. L. A.

President
L. Glenn Hall, San Francisco

Vice President
Helen Van Pelt, San Anselmo

Secretary-Treasurer
Geraldine Knight, San Anselmo

National Park Policies

The second conference on National Parks held recently in Washington has presented certain policies which concern the profession of landscape architecture. Lay organizations particularly interested in the scope and development of National Parks have not hesitated to express themselves relative to the use and treatment of National Park areas. All officials and representatives of various government bureaus agreed that National Parks should be of National interest and importance and of "high inspirational quality." According to A. D. Taylor, President of the American Society of Landscape Architects, the Society believes that "additional land for National Parks should be acquired until the available superlative scenery of National Park quality is under control of the National Park Service. Landscape architects interested in this conference may refer to the January-March, 1938, number of "Planning and Civic Comment."

Bicycling Through Europe

On April 21st, Fran Violich, graduate of the Division of Landscape Design, University of California, and of Harvard University, presented a very fine illustrated lecture of his bicycle tour through Europe. Members of the Landscape Design Club at the University of California and their friends were especially interested in the illustrations showing many recent modern parks and gardens and city planning projects in Germany, Holland, Italy, France and England. A few interesting views were shown of Dalmatia, a country seldom visited by tourists. Pictures of the Paris Exposition were also of great interest. Mr. Violich is now with Mark Daniels, who is planning many of the courts of the International Exposition on Treasure Island.

Summer Trip for Landscape Students

Professor J. W. Gregg, head of the Division of Landscape Design, University of California, announces that five major students will be directed on a summer traveling trip for one month for the purpose of studying estates, parks, subdivisions and office practice in landscape architecture. The regions concerned will be the Peninsula, Marin County, Sacramento, Stockton and Santa Barbara. Those taking this traveling course which is required for graduation are: Miss Shirley E. Chamber-

lain; Messrs. Chas. Samms, Wm. Seabury, Samuel Jung, Robert Murray.

Landscape Work Under Way

W. Dorr Legg, Assistant Professor of Landscape Architecture, Member of the A. S. L. A., reports that he has prepared a general plan for the development of the Oregon State Fair at Salem. Arrangements for future building program with emphasis on circulation to meet modern traffic requirements, have been studied and planned.

Garden Work in Progress

E. Leslie Kiler, landscape architect, A. S. L. A. of Palo Alto, reports the following garden construction:

Native garden for Mr. and Mrs. George Egleston, Brookdale, California.

Garden for Miss Elizabeth Gamble, Palo Alto. Chas. K. Summer, architect.

Garden for Mr. and Mrs. Walter Severson, Atherton. Farr & Ward, architects.

Garden for Mr. and Mrs. Paul Hanna, Stanford University. Frank Lloyd Wright, architect.

Grounds for Stanford Memorial Hall. Bakewell & Weihe and Arthur Brown, architects.

Garden for Mr. and Mrs. W. F. Wuthman, Los Altos. Gardner Dailey, architect.

Landscape Architect Enlarges Offices

Butler Sturtevant, A. S. L. A., has recently moved into larger offices at 210 Post Street, San Francisco. Of unusual interest is the very vivid color scheme worked out by Elizabeth Banning, noted color consultant, where she has achieved some very startling effects. The ceiling in the drafting room is a chalky blue with off white walls, and the conference room has a carpet greener than any lawn. Mr. Sturtevant travels perhaps more than any other landscape architect in the West with his work for the University of Washington in Seattle and the Principia College development in Elmhurst, Illinois. Some of his recent work was published in "Country Life."—W. H. S.

BERKELEY ARCHITECT MOVES

Frederick L. Confer has moved from Claremont Avenue, Berkeley, to his new studio in the Claremont Hotel, head of Russell Street, Berkeley. Mr. Confer is quite busy on residence work in Alameda and Contra Costa Counties.

Contemplated improvements at the Hotel Claremont include a cocktail lounge and exterior painting.

Pacific Coast Architects' Chapters

NORTHERN CALIFORNIA CHAPTER

The regular monthly meeting of Northern California Chapter, A. I. A., was held at the St. Francis Yacht Club, at 6:30 p. m., Tuesday, March 29, Warren C. Perry presiding.

After consideration of ways to increase attendance at the meetings, a motion was made by Mr. Weihe for the appointment of an attendance committee. Mr. Hertska proposed an amendment that it also be a program committee. The amendment and motion were unanimously carried.

Mr. Perry told of the steps taken by the Chapter to secure architectural representation on the San Francisco Housing Authority, now in process of appointment. He mentioned the possibility of a closely related Advisory Architectural Commission, if no architect members are appointed to the Authority.

Mr. Evers spoke of the serious proposals to convert the Institute from a society of architects, devoted to certain principles to an open society inclusive of all architects. This, he stated, was the subject for discussion in the recent conference of Western representatives of the Institute Committee on State Organization, leading to the recommendation that the convention be asked to give the present State Association plan a more thorough trial and that the Chapters in Washington, Oregon, and Arizona be asked to sponsor the setting up of State Associations in their respective States.

Mr. Allen thought that the Chapter might well adopt these principles, because of the ten years of successful operation of the Association in California in close harmony and co-operation with the Chapters.

Consideration of the subject was ended by the passing of two motions made by Mr. Evers, as follows:

1. That the Chapter endorse the present status of State Associations with the Institute, but with recommendation for increased representation in the Institute's conventions.

2. That the Chapter contact the Chapters of Arizona, Oregon and Washington State and urge them to sponsor the organization in these states of Associations as now set-up in California.

A further matter of business was consideration of the request of Oregon Chapter for endorsement of its effort to have the Equalization and Refund System restored in connection with expenses of delegates to the conventions.

The motion of Mr. Allen was carried that the delegates be requested to do what they can in behalf of the matter and that the Chapter's endorsement be sent to the Institute for submission to the Board of Directors.

Mr. Perry brought up the matter of joining the New York competition organization for the promotion of competitions for public works. He stated that the Executive Committee had felt that it should not be too impetuous in making this affiliation, notwithstanding the authorization extended in a previous meeting for it to do so.

Thereupon, Mr. Wurster moved and it was carried that the Chapter reaffirm its championship of competitions as a proper means of awarding public works and substantiate the officers in their discretion to delay membership in this organization until after the convention.—J. H. M.

ARCHITECTS TOLD OF HOUSING ACT

At the April 12 meeting of Southern California Chapter, A. I. A., features of the National Housing Act were explained by leaders in the movement, in answer to questions by various Chapter members. Some 125 architects were present. Harris C. Allen of San Francisco, associate editor of *The Architect and Engineer*, gave an informal talk on the Housing Bill. As Architectural Consultant for the Federal Housing Administration, Mr. Allen has been giving talks before members of the profession as far North as Seattle. At the Los Angeles meeting, he explained that the act was amended to stimulate building construction and business in general by facilitating the construction of large scale housing projects and to reduce the cost of purchasing small homes.

Economical large scale developments designed for families in the moderate and low income groups should be given special attention, he said, for they constitute a broad market. The architect is really essential to the durability of buildings that can qualify for FHA insurance, he added, and he should have more of the expected one to three billion dollars worth of business that will develop as a result of the amended law.

Mr. Allen's talk was accompanied by a motion picture of four large FHA insured rental projects that are said to be very successful. They are the Falkland Properties, Silver Spring, Maryland; Buckingham Community, Arlington, Virginia; Chatham Village, Pittsburgh, Pennsylvania, and Colonial Village, Arlington, Virginia.

An announcement of three sessions for the purpose of informing architects of the amended sections of the Federal Housing Act was made by W. W. Nixon of Washington, D. C., mortgage conference representative of the FHA. The meetings will be held at the Biltmore Hotel in Los Angeles, April 26 and 27, the first to be a talk on Sections 207 and 210 by Eugene H. Claber, past president of the Chicago Chapter, The

American Institute of Architects. The second meeting will be devoted to the subject of building up the loan application, and the third to illustrations on Sections 207 and 210.

Frank E. Marsh, FHA official, told of the experience of City and Suburban Homes Company of New York, which has successfully conducted a housing business for the past 24 years. Another speaker was Captain W. G. Bingham, associate director of the FHA in Southern California, who stated that applications for mortgage insurance from his district during the month of March represented \$14,000,000 worth of building, \$7,500,000 of it for new construction. He also said that in order to take care of this added business it had been necessary to increase their staff from 211 to 276 employees.

Ford J. Twaits, president of the Southern California Chapter, Associated General Contractors of America, and a member of the national advisory board of that organization, invited the architects to attend an FHA meeting they were sponsoring in the Times Auditorium.

Carleton M. Winslow presented Kenneth Wing of Long Beach with a certificate of membership in the Chapter and S. Graham Latta of Glendale, a certificate of associate membership.

Eugene Weston, Jr., who presided at the meeting, introduced B. Marcus Priteca of Seattle, president of the Washington State Chapter of the Institute, and Huber Earl Smutz of the Los Angeles city planning department.

OREGON CHAPTER

The regular meeting of Oregon Chapter, A. I. A., was held April 19th at Hilaire's Restaurant, Portland, Oregon. The following were present: Messrs. Howell, Jones, Aandahl, Johnston, Morin, Jacobberger, Doty, Stanton, Brookman, Holford, Perrin, Herzog, Parker, Wick, Fritsch, Marsh, Boles, Hilgers, Morden, Baer, Kotchik, Sundleaf, I. Smith, Nielsen, Zeller. Guest: Mr. Orrin E. Stanley.

Mr. Stanton spoke on weekly radio broadcasting series, sponsored by the O. B. C. on home construction, to be given over station KOAC, Corvallis and asked for support in preparing scripts for the broadcasts. The series will be repeated later in Portland.

Howard Perrin, of Klamath Falls, spoke briefly regarding contingent liability insurance for injuries to architects or their employees on construction jobs—asked for suggestions.

President Howell then called upon Mr. Stanley, of the City Engineers' office and past president of the local Chapter of the A. S. C. E., who showed a remarkable series of colored lantern slides developed from photographs he took on a recent trip through old Mexico. From an architect's point of view these films were the finest entertainment this Chapter has had in years and President Howell expressed our appreciation and thanks for Mr. Stanley's kindness in showing them. The pictures were mostly of architectural details of Mexican

churches and were taken with a standard Model A Leica, F 35 lens camera with films 1" x 1 1/2". The color process developing is done by the Eastman Company in Schenectady, costing \$2.50 for a roll of 18 shots.

Mr. Holford reported for the competitions committee, having received a letter from Mr. Crowell advising him of House Bill 10247 on competitions which was prepared by the Institute. Advised Chapter to defer action until report from the Convention at which time competitions will be discussed.

Mr. Jacobberger reported for the Industrial Relations Committee (1) Stock Mouldings: Due to opposition from individual Chapter members, Nicolai's proposal was rejected and (2) Plumbing & Heating Contractors' Association: Typewritten and unsigned explanation from this group in reference to their bid practices was read in part and considerable discussion ensued. Question was tabled and report ordered filed without action.

Mr. Jacobberger advised Chapter to prepare to meet with Oregon State Federation of Professional Societies relative to proposed legislation for 1939 session. The president authorized to draw up new slate of our representatives on this group.

Mr. Doty requested that Chapter go on record as being opposed to activities of Allison Dean, realtor, in the matter of designing homes. Motioned and voted that executive committee appoint a special committee, with power to act, to ask Mr. Dean for an explanation of these activities as defined by advertisements which have been appearing in local papers.

Secretary Morin reported executive committee's negative decision regarding participation in Oregon Journal publicity campaign and reasons therefor.

Mr. Jacobberger took exception to the FHA publicity regarding 90% insured loans. Discussion ensued with explanations from FHA Administrator Parker.—R. L. M.

ARIZONA CHAPTER, A. I. A.

Leslie J. Mahoney of Phoenix, has been elected president of Arizona Chapter, American Institute of Architects, succeeding Roy Place of Tuscon. Other officers this year are: M. H. Starkweather, Tuscon, vice president; Fred Whittlesey, Phoenix, secretary; Richard Morse, Tuscon, treasurer, and Royal W. Lescher, member of the executive committee. The Chapter now has 30 members.

RESIDENCE BUILDING IMPROVES

Some noticeable improvement in the construction of private dwellings is reported in the San Francisco and East Bay area. Banks and other financial institutions have commenced to make new loans under the Federal Housing Act, and indications point to a continued resumption of home building from now on. The absence of architects' names to plans has been noticed in reports of small houses. A closer affiliation of the architects with the lending institutions would seem to be important at this time.

ARCHITECTS' BULLETIN

Issued For

THE STATE ASSOCIATION OF CALIFORNIA ARCHITECTS
Northern Section

ARCHITECTS' FHA MEETINGS

THE first regional meeting of architects to discuss provisions of the new National Housing Act was held in San Francisco on April 5th. Due to late delivery of notices, there was not a large attendance; but many informative points were brought out. Meetings held later, at Portland, Seattle and Los Angeles, were very well attended and showed active interest of architects generally in the opportunities open to the profession in large-scale housing projects as now sponsored by the FHA.

Surveys throughout the country, including California, have shown a definite shortage of adequate rental housing accommodation for wage-earning and salaried families of moderate income. It is also a matter of historical record that such projects, when well constructed and managed, have the greatest stability in both occupancy and return on the investment. For example, one large Eastern company has a record of over 40 years average return of 4.65%, never having passed a dividend; it operates 10,000 rooms at an average rent of \$9.00 per room per month. Its average of vacancies for the entire period was 3.39%. Such an example—and many similar ones could be cited—is the most convincing proof of the economic soundness in this type of long-time investment.

Since durability of building is essential, including good design and planning to prevent obsolescence and insure easy maintenance, this field becomes the province of the architect and it is so recognized by the FHA and approved mortgage lending institutions.

Moreover, there are excellent reasons why architects should take an active and leading role in starting such projects. Such a policy is approved by the A. I. A. Housing Committee, and is welcomed by the FHA. It assures a high standard and commends the project to the attention of conservative individuals and corporate or trustee bodies of integrity, who desire to put their funds into safe long-term investments.

Since this procedure requires both knowledge of the provisions of Sections 207 and 210 of the Act, and certain conditions affecting site and neighborhood which must be determined in advance, it is desirable for architects to secure the necessary information from the nearest FHA office. This is available both in the form of printed circulars, and through personal interviews. It will be found that FHA officials are anxious to assist architects in every way possible, in order to expedite the development of sound building projects and prevent waste of effort and time.



DELEGATE MICHELSEN

President Harry Michelsen went to the A. I. A. Convention at New Orleans as delegate from our Association. He went well primed to demonstrate the satisfactory experience of the "California Plan" as worked out in ten years, and the harmonious co-ordination of activities between the Association and the A. I. A. Chapters. No better plan has been suggested for

STATE ASSOCIATION MEMBER
OF THE
AMERICAN INSTITUTE OF ARCHITECTS

Editor

Harris C. Allen

Address all communications for publication
of the Bulletin to the Editor (Harris C.
Allen) 557 Market Street, Room 218, San
Francisco, California.

Board of Control

Harris C. Allen Otto G. Hintermann
Harry Michelsen Ellsworth E. Johnson
 Chester H. Miller

State Association Officers

Harry M. Michelsen, San Francisco, President
George D. Riddle, Los Angeles, Vice-Pres.
Luis N. Crawford, Santa Maria, Secretary
Otto G. Hintermann, San Francisco, Treas.

Regional Director, A. I. A.

Albert J. Evers, San Francisco

Representative of Regional Director, Southern California

Gordon B. Kaufmann, Los Angeles

Executive Board—Northern Section Officers

Harry M. Michelsen.....President
Clynn Officer.....Vice-President
Ellsworth E. Johnson.....Secretary
Otto G. Hintermann.....Treasurer

Directors

Walter E. Beumberger William G. Merchant
Harry J. Devine Frederick H. Reimers

Executive Board—Southern Section Officers

George D. Riddle.....President
Gordon B. Kaufmann.....Vice-President
Luis N. Crawford.....Secretary
Albert H. Orr.....Treasurer

Directors

Harold C. Chambers Lester G. Hibbard
M. Edelman W. P. Lodge

S. B. Marston

Advisors—Northern Section

Harris C. Allen Edward R. French, Jr.
F. Ashley Arthur F. Dodman
K. Ballantine Joseph Losekann
Wayne S. Hertzka David H. Horn
Conrad T. Kett Robert Stanton
J. I. Garren Charles S. McKenzie
O. G. Merchant Henry C. Collins
Thomas E. Pring Leo J. Sharps
Incent Raney Carl F. Gromme
H. Reimers C. C. Dakin
Edward O. Blodgett F. T. Georgeson
George P. Simonds Ralph D. Taylor
Clynn Officer

unification of the profession nationally than the present affiliation of state organizations with the Institute as Association Members, with adjustments to improve working conditions as need arises.

DRAFTSMEN'S REGISTRATION

Miss Kragen, office secretary, reports

that more draftsmen have been placed with architects and fewer have registered desiring employment, during the past month, than for the past six months' period. This service to the profession is a continuing and valuable activity of the Association.

COMPETITION FOR ART CENTER

More than 400 entries have been received in the competition to select an architect for a proposed Art Center for Wheaton College for Women at Norton, Massachusetts.

Perhaps the most important major competition held in the United States since the 1922 Chicago Tribune Tower project, its challenging problems have secured the participation of many prominent architects; in addition to the four invited firms, Gropius and Breuer, Cambridge, Massachusetts; William Lescaze, New York City; Lyndon and Smith, Detroit, and Richard J. Neutra, Los Angeles, who were selected for their achievements in building schools of modern design.

The purpose of the Art Center is to provide a building or related group of buildings to serve the common and individual needs of the departments of Art, Dance, Drama and Music, which are closely related in curricular activities, and such extra-curricular activities as lectures, concerts, exhibitions and dramatic productions.

A theater seating 500 persons, a rehearsal room having the same width and depth of stage as the actual theater, and all the dramatic department work-shops, such as painting, designing property room and sewing rooms, as well as dressing rooms, are required. There will be a smaller auditorium for lectures, dancing and concerts. There will be class rooms, studios and practice rooms, all sound proof, for the Department of Music. A library for books, photographs, slides, records and all such special equipment as is necessary for these departments will be included, as well as offices for each of the departments.

The contest will close midnight, May 24, and the names of the judges will be announced June 2, the first day of judging.

COLUMBIA FELLOWSHIPS

Award of two fellowships and an exchange scholarship in the Columbia University School of Architecture is announced by Dean Leopold Arnaud.

The \$2,000 McKim fellowship, given every three years to a graduate of the school, has been granted for

1938-39 to Harry Beardslee Brainerd of 681 Fifth Avenue, New York City, architect and city planner. Mr. Brainerd will investigate the educational, legislative, and physical correlation of civic design with city planning in the principal cities of Europe. The research, which will have the scope of a doctoral dissertation, is expected to be of value to the entire architectural profession.

A \$1,500 University fellowship goes to Herbert D. Phillips of 240 West End Avenue, New York City, senior in the School of Architecture, for graduate work leading to the master of science degree.

Richard Compton Harrison, Jr., of 120 East End Avenue, New York City, graduate of the School of Architecture in 1937, has been appointed exchange scholar to the University of Rome. An Italian student chosen by the Italian Government will study architecture at Columbia.

AWARDED ION SCHOLARSHIP

Edward M. Hicks of Portland, Oregon, has been awarded the Ion Lewis Traveling Scholarship in Architecture, of the University of Oregon, for 1938. Hicks finished at the University in 1934, and was awarded a scholarship at the Massachusetts Institute of Technology where he did his graduate work. He then spent a year in Washington, D. C., in the employ of Kenton Hamaker, and later worked in the offices of Trowbridge and Livingston in New York.

The Ion Lewis Scholarship provides an annual award of \$1,000.00 to University of Oregon students, or graduates, who are eligible. This is the fifth award. Arthur Riehl, the fourth fellow and holder of the 1937 award, is now studying in Vienna.

Ellis F. Lawrance, Dean of the School of Architecture, University of Oregon; Hollis Johnston, and Glenn Stanton, Portland architects, are the managing committee.

NEW CORNELL DEAN

Gilmore D. Clarke, nationally known landscape architect, chairman of the National Commission of Fine Arts, and professor of City and Regional Planning at Cornell University since 1935, has been appointed dean of the College of Architecture, effective July 1. Dr. Clark will succeed Dean George Young, Jr., the incumbent since 1927, who will remain on the faculty as Professor of Architecture. Professor John N. Tilton, Jr., who has been acting dean during the recent leave of absence of Dean Young, will become assistant dean of the college on July 1.

SAN MATEO SHOP BUILDINGS

For remodeling the San Mateo High School shop building a bond election for \$49,000 will be held June 3rd. Harold B. Hammill, structural engineer, 381 Bush Street, San Francisco, is preparing the plans.

Structural Engineers Association of Northern California

OFFICERS

Harold B. Hammill, President

S. S. Gorman, Vice President

H. M. Engle, Secretary-Treasurer

Other Directors:

F. F. Hall

A. V. Saph, Jr.

DYNAMIC SHEARS IN A 16-STORY MODEL

Following is a technical report of the recent laboratory demonstration and discussion of results of dynamic shears in a 16 story building model, at Stanford University, conducted under the auspices of the Structural Engineers Association of Northern California:

The Model is made of 16 duralumin plates mounted one above the other in such a way that each plate is supported vertically at its center of gravity by a ball type of carriage which allows five degrees of freedom to the plate. A total of 5×16 or 80 degrees of freedom are therefore present, but since the model represents a somewhat idealized office building with two-fold symmetry, and since the experiments have been restricted to a ground motion of one direction only, a total of 32 degrees of freedom enter into the experiments. Moreover, since primary interest centers around the dynamic shears, only the sixteen displacement coordinates, i. e., sixteen degrees of freedom, are given detailed consideration.

The model attempts to give a true picture of the dynamic behavior of an idealized, elastic prototype, both in regard to shear and flexure. The elastic ground distortion is also taken into account, but the values of the ground rigidities are somewhat arbitrarily taken. The linear scale of the model is 1 to 50; the weight scale is 1 to 503, and the moment of inertia scale is 1 to 505. Each plate is connected to adjacent plates by two sets of springs—plate springs for vertical distortions, and coiled springs for horizontal distortions. The plate springs represent the flexural rigidity of the prototype to the scale of 1 to 505, and the coiled springs represent the horizontal shearing rigidity of the prototype in the ratio of 1 to 503. As a result of these scales the periods as well as the dynamic displacements of the model stand in a one-to-one ratio with those of the prototype. The dynamic distortion scale of the model is 50 to 1. Shear distortion indicators are provided on every floor of the model.

The Ground Motion is a transitory, impact type of harmonic motion with a definite period and damped by rubbing friction so as to last for a definite length of time, namely, 2.2 seconds. The intensity of the ground motion is defined by the maximum harmonic velocity occurring in the beginning of the motion, and this velocity is kept constant whatever may be the harmonic period. A maximum velocity of 1 inch per second has been taken as an arbitrary intensity. At a period of 1 second this velocity corresponds to a harmonic maximum acceleration of 1.63 per cent gravity, at a period of $1/2$ second it corresponds to 3.26 per cent gravity, and at a period of $1/10$ second the correspondence is 16.3 per cent gravity. Altogether, about sixty different periods ranging from 0.1 second to 1.8 seconds have been used in the tests.

The Tests were made primarily to ascertain whether or not the existing methods of design were applicable to "normal" types of buildings, but in addition to this purpose it was considered interesting to see how a "normal" building would compare with one having a decidedly flexible first story. But what is a "normal" first-story rigidity? Since this question is somewhat difficult to answer, it was considered better to compare all the tests to those on a

uniformly rigid first story building, defining "uniformly rigid" as having the same shearing rigidity in the first story as in those immediately above it. However, the term "normal" has been retained in the tests as referring to the actual prototype of the model. By changing the horizontal springs in the first story of the model, four distinct models have been made. They are:

- (a) Uniformly rigid first story model . . . $k_2/k_1 = 1$
- (b) "Normal" first story model . . . $k_2/k_1 = 4.6$
- (c) Slightly flexible first story model . . . $k_2/k_1 = 6.6$
- (d) Very flexible first story model . . . $k_2/k_1 = 19.0$

Results:

1. The current design rule prescribing a triangular, horizontal load distribution applies quite well to a building when only the fundamental mode motion is considered.

2. When the second mode motion is probable as well as when other higher modes must be taken into account, a trapezoidal load distribution is indicated as being more rational than the triangular.

3. Flexibility in the first story reduces the dynamic shears in the superstructure, as well as in the first story itself.

4. The shear reduction is least for the fundamental mode, being respectively 91, 74, and 55 per cent of the uniformly rigid first story model for models (b), (c), and (d).

5. The shear reduction for the second mode motion is greater than for the fundamental mode; in other words, the efficiency of the flexibility is increased. It is: 78, 60, and 25 per cent for the models (b), (c), and (d).

6. For the third mode motion, the dynamic shears are reduced to 69, 52, and 21 per cent of the uniformly rigid first story model.

7. For the fourth mode motion, the figures are: 47, 42, and 19 per cent.

B. Considering the period intervals between the fundamental and the fourth mode periods as being representative of the period range that may be encountered in an actual earthquake, the average dynamic shears in the superstructure compared to the average shear in the uniformly rigid first story model are as follows:

- 69 per cent for the "normal" first story model.
- 55 per cent for the slightly flexible first story model.
- 26 per cent for the very flexible first story model.

STANDING COMMITTEES FOR 1938

The Structural Engineers Association of Northern California have named the following chairmen of standing committees for the year:

Advisory, S. S. Gorman; Professional Guidance, T. P. Dresser, Jr.; Committee on Relation Between Employers and Employees, H. C. Powers; Program, H. A. Schirmer; Professional Activities and Welfare, A. W. Earl; Legislative, J. Rosenwald; Membership, J. G. Wright; Fees, L. H. Nishkian; Structural Engineering and Research, F. P. Ulrich; Committee on Attendance, K. Theill; Disaster Program, City of Berkeley, J. G. Wright; Publicity, William H. Popert.

STUDENTS GUESTS OF S. E. A.

A sizeable delegation of structural engineering students of the San Francisco Bay Area were guests of the Structural Engineering Association of Northern California at their monthly dinner meeting at the Engineer's Club, April 5. Of the 100 members and guests attending, 22 were students of the University of California, Stanford, Santa Clara, and the College of the Pacific. Other guests included the deans and professors of Engineering of the colleges.

Introductory remarks were given by the faculty representatives of the several colleges. Then the students were introduced and each gave a short talk on some subject that interested him. The topics chosen dealt mainly with the theses which the students had worked on, ranging from a description of one student's recent trip to a description of another student's home town. The students were then given the opportunity of asking any question they desired of the members of the Association present. The members who answered the questions indicated by the adequacy of their replies that they had given considerable thought to the subjects. In the short time allotted for the talks, both students and members quite belied the popularly held conception that to be an engineer one must be incoherent.

The Structural Engineers Association of Northern California can be justly proud of the interest and consideration they have shown to the young engineer just out of college. By pioneering a program of officially helping young graduates, the members of the Association have done much toward the furthering of the ideals of an eminent profession in the minds of the engineers of the future.

ANNUAL OUTING

The annual picnic and barbecue of the Structural Engineers of Northern California will be held Saturday, June 4 at the Phelan country estate, near Saratoga.

INFORMATION FOR ENGINEERS

A course of free lectures on "Moment Distribution Applied to Concrete Building and Bridge Frames" is being given for the benefit of Los Angeles structural engineers by Professor David M. Wilson of the College of Engineering, University of Southern California. The lectures are held in the conference room of the Biltmore Hotel, consecutive Monday's in May and June, and are sponsored by the Portland Cement Association.

The talks deal with moment distribution as applied to important problems which arise in design of concrete frames in buildings and bridges. Professor Wilson has given special study to such problems and has made outstanding contributions to their solution.

The American Concrete Institute building code and the Progress Report of the joint committee now both state that building frames must be analyzed as continuous structures, not as individual units of beams and

columns. And in bridge design, the use of continuous beams and frames has recently grown to a considerable extent. These and related subjects will be analyzed by application of the moment distribution method. The course is arranged specifically for professional engineers engaged in the design of buildings and bridges.

STEEL HOUSES FOR WORLD'S FAIR

Housed in ultramodern steel bungalows, and employing other "attention getters," a \$40,000 exhibit of the Christian Business Men's Committee will present a "business appeal for Christianity" at the Golden Gate International Exposition in 1939.

The committee, made up of business men from many creeds, has leased 8,000 square feet of outdoor space at one of the Fun Zone exits on Treasure Island, site of the Western World's Fair on San Francisco Bay. In this strategic location the committee will seek to interest the "complacent business man or woman."

Two or perhaps three of the new Le Tourneau portable steel dwellings will be set up. R. G. Le Tourneau, Vice President of Christian Business Men's International, devised this novel steel bungalow for his factory personnel at Peoria, Ill.

The standard welded structure is 32 by 44 feet in size, weights 41 tons, and may be dropped three feet without damage. Fabricated in the factory, many of them have been moved on trailers to building lots, where a derrick engages three steel rings in the roof and places the house on its foundations.

One of these houses on Treasure Island will be fitted up as a dwelling for exhibition purposes; another will be offices for the committee sponsoring the presentation, and a third steel house may contain a Bible exhibit. Other spectacular features will present Christianity in convincing form to the business man.

In a large steel auditorium the committee will present, several times daily, Irwin A. Moon and his "Sermons from Science," a series of scientific phenomena illustrating spiritual truths. More than a ton of electrical and scientific equipment allows Moon to pass a million volts through his body, cause metal to float in space, turn dull gray rocks into glowing gems, project the voice on a beam of light, and achieve other astonishing effects.

PROVISIONAL CERTIFICATES

The California State Board of Architectural Examiners, Southern Division, April 12 issued provisional certificates to the following persons to practice architecture in California: Nicholas M. Cirino, 3759 Woodlawn Avenue, Los Angeles; Charles Eugene Fry, 241 Cresta Avenue, San Gabriel; Ernest Lynn McCoy, 1215 Nile Street, Bakersfield; Benjamin Stiger Parker, 1180 Lorain Road, San Marino; Chester Reginald Phillips, 2316 Observatory Avenue, Los Angeles; Albert John Haight, 861 Highland Avenue, Highgrove; Stephen Ackland Stepanian, 9140 Santa Monica Boulevard, Beverly Hills.

Estimator's Guide

Giving Cost of Building Materials, Wage Scale, Etc.

Amounts given are figuring prices and are made up from average quotations furnished by material houses to San Francisco contractors. 3% Sales Tax on all materials but not labor.

All prices and wages quoted are for San Francisco and the Bay District. There may be slight fluctuation of prices in the interior and southern part of the state. Freight charge, at least, must be added in figuring country work.

End—1/2% amount of contract.

Work—

Common, \$40 to \$45 per 1000 laid, (according to class of work).
Face, \$100 to \$110 per 1000 laid, (according to class of work).
Brick Steps, using pressed brick, \$1.25 lin. ft.
Brick Veneer on frame buildings, \$.75 sq. ft.
Common f.o.b. cars, \$14.00 at yard. Cartage extra.
Face, f.o.b. cars, \$45.00 to \$50.00 per 1000, carload lots.

DOLLOW TILE FIREPROOFING (f.o.b. job)

3x12x12 in. \$ 84.00 per M
4x12x12 in. 94.50 per M
6x12x12 in. 126.00 per M
8x12x12 in. 225.00 per M

DOLLOW BUILDING TILE (f.o.b. job)

carload lots.
8x12x5/2 \$ 94.50
6x12x5/2 73.50

Building Paper—

1 ply per 1000 ft. roll \$3.50
2 ply per 1000 ft. roll 5.00
Brownskin, 500 ft. roll 6.25
Brownskin, Pro-tect-o-mat, 1000 ft. roll 9.00
Sisakraft, 500 ft. roll 5.00
Sash cord com. No. 7 \$1.20 per 100 ft
Sash cord com. No. 8 1.50 per 100 ft
Sash cord spot No. 7 1.90 per 100 ft
Sash cord spot No. 8 2.25 per 100 ft
Sash weights cast iron, \$50.00 ton.
Nails, \$3.50 base.
Sash weights, \$45 per ton.

Concrete Work (material at San Francisco bunkers)—Quotations below 2000 lbs. to the ton. \$2.00 delivered.

No. 3 rock, at bunkers.....\$1.45 per ton
No. 4 rock, at bunkers..... 1.45 per ton
Elliott top gravel, at bunkers 2.10 per ton
Washed gravel, at bunkers..... 1.45 per ton
Elliott top gravel, at bunkers 2.10 per ton
City gravel, at bunkers..... 1.45 per ton
River sand, at bunkers..... 1.40 per ton
Delivered bank sand..... 1.00 cu. yd.

ote—Above prices are subject to discount of 2% per ton on invoices paid on or before the 10th of month, following delivery.

AND

Del Monte, \$1.75 to \$3.00 per ton.
Fen Shell Beach (car lots, f.o.b. Lake Matiello), \$2.75 to \$4.00 per ton.

Cement (paper sacks) \$3.00 bbl., warehouse or delivery.

Car-load lots delivered \$2.70, f.o.b. cars \$2.52

(Cloth sacks) \$3.00 bbl..

Rebate 10 cents bbl. cash in 15 days.

Atlas White (1 to 100 sacks, \$1.50 sack, warehouse or delivery; over 100 Calaveras White sacks, \$1.25; 2% discount 10th of month.)
Medusa White (of month.)

Forms, Labors average \$40.00 per M.

Average cost of concrete in place, exclusive of forms, 35c per cu. ft.; with forms, 60c.

4-inch concrete basement floor

.....12 1/2c to 14c per sq. ft.

Rat-proofing

Concrete Steps\$1.25 per lin. ft.

Dampproofing and Waterproofing—

Two-coat work, 20c per yard.

Membrane waterproofing—4 layers of saturated felt, \$4.50 per square.

Hot coating work, \$1.80 per square.

Medusa Waterproofing, 15c per lb., San Francisco Warehouse.

Tricocel waterproofing.

Electric Wiring—\$12.00 to \$15.00 per outlet for conduit work (including switches).

Knob and tube average \$3.50 per outlet.

Elevators—

Prices vary according to capacity, speed and type. Consult elevator companies.

Average cost of installing an automatic elevator in four-story building, \$2800; direct automatic, about \$2700.

Excavation—

Sand, 60 cents; clay or shale \$1 per yard.

Teams, \$12.00 per day.

Trucks, \$22 to \$27.50 per day.

Above figures are an average without water. Steam shovel work in large quantities, less; hard material, such as rock, will run considerably more.

Fire Escapes—

Ten-foot galvanized iron balcony, with stairs, \$115 installed on new buildings; \$140 on old buildings.

Floors—

Composition Floors—22c to 40c per sq. ft.

In large quantities, 16c per sq. ft. laid.

Mosaic Floors—80c per sq. ft.

Duralex Floor—23c to 30c sq. ft.

Rubber Tile—50c to 75c per sq. ft.

Terazzo Floors—45c to 60c per sq. ft

Terazzo Steps—\$1.60 lin. ft.

Hardwood Flooring (delivered to building)—

3/4x2 1/4" T & G Maple \$ 88.00 M ft.

1 1/4x2 1/4" T & G Maple 115.00 M ft.

3/8x3/4" sq. edge Maple 100.00 M ft.

	3/4x2 1/4" T&G	3/8x2 1/4" T&G	3/4x2" Sq. Ed.
Clr. Qtd. Oak	\$120.00 M	\$ 82.50 M	\$110 M
Sel. Qtd. Oak	99.00 M	63.50 M	84 M
Clr. Pla. Oak	106.00 M	74.50 M	86 M
Sel. Pla. Oak	97.00 M	62.50 M	76 M
Clear Maple	111.00 M	100.00 M	
Laying & Finishing	14c ft.	12c ft.	10c ft.
Wages—Floor layers	\$10.00.		

Note—Above quotations are all board measure except last column which is sq. ft.

Glass (consult with manufacturers)—

Double strength window glass, 20c per square foot.

Plate 75c per square foot (unglazed) in place, \$1.00.

Art, \$1.00 up per square foot.

Wire (for skylights), 40c per sq. foot.

Obscure glass, 30c square foot.

Glass bricks, \$2.40 per sq. ft., in place.

Note—If not stipulated add extra for setting.

Heating—

Average, \$1.90 per sq. ft. of radiation, according to conditions.

Warm air (gravity) average \$40 per register.

Forced air, average \$60 per register.

Iron—Cost of ornamental iron, cast iron, etc., depends on designs.

Lumber (prices delivered to bldg. site).

No. 1 common \$29.00 per M
No. 2 common 27.00 per M
Select O. P. common 34.00 per M
2x4 No. 3 form lumber 24.00 per M
1x4 No. 2 flooring VG 55.00 per M
1x4 No. 3 flooring VG 47.00 per M
1x6 No. 2 flooring VG 60.00 per M
1 1/4x4 and 6, No. 2 flooring 60.00 per M

Slash grain—

1x4 No. 2 flooring \$43.00 per M
1x4 No. 3 flooring 40.00 per M
No. 1 common run T. & G. 30.00 per M
Lath 5.25 per M

Shingles (add cartage to price quoted)—

Redwood, No. 1 \$1.10 per bdle.
Redwood, No. 290 per bdle.
Red Cedar 1.10 per bdle.

Millwork—Standard.

O. P. \$85.00 per 1000. R. W., \$90.00 per 1000 (delivered).

Double hung box window frames, average, with trim, \$6.50 and up, each.

Doors, including trim (single panel, 1 3/4 in. Oregon pine) \$8.00 and up, each.

Doors, including trim (five panel, 1 3/8 in. Oregon pine) \$6.00 each.

Screen doors, \$3.50 each.

Patent screen windows, 25c a sq. ft.

Cases for kitchen pantries seven ft. high, per lineal ft., \$8.00 each.

Dining room cases, \$8.00 per lineal foot. Rough and finish about 75c per sq. ft.

Labor—Rough carpentry, warehouse heavy framing (average), \$17.50 per M.
For smaller work average, \$35.00 to \$45.00 per 1000.

Marble—(See Dealers)

Painting—

Two-coat work	36c per yard
Three-coat work	50c per yard
Cold Water Painting	10c per yard
Whitewashing	4c per yard
Turpentine, 65c per gal., in 5 gal. cans, and 55c per gal. in drums.	
Raw Linseed Oil—97c gal. in bbls.	
Boiled Linseed Oil—\$1.00 gal. in bbls.	
Medusa Portland Cement Paint, 20c per lb.	

Pioneer or Dutch Boy White Lead in Oil (in steel kegs).

	Per lb.
1 ton lots, 100 lbs. net weight	10/4c
500 lbs. and less than 1 ton lots	10/6c
Less than 500 lb. lots	11c

Pioneer or Dutch Boy Red Lead and Litharge (in steel kegs).

1 ton lots, 100 lb. kegs, net weight	10/4c
500 lbs. and less than 1 ton lots	10/2c
Less than 500 lb. lots	11c

Pioneer Red Lead in Oil (in steel kegs)

1 ton lots, 100 lb. kegs, net weight	11/4c
500 lbs. and less than 1 ton lots	11/2c
Less than 500 lb. lots	12c

Note—Accessibility and conditions cause some variance in costs.

Patient Chimneys—

6-inch	\$1.25 lineal foot
8-inch	1.75 lineal foot
10-inch	2.25 lineal foot
12-inch	3.00 lineal foot

Plastering—Interior—

	Yard
1 coat, brown mortar only, wood lath	\$0.75
2 coats, lime mortar hard finish, wood lath	.80
2 coats, hard wall plaster, wood lath	.85

3 coats, metal lath and plaster	1.30
Keene cement on metal lath	1.30
Ceilings with 3/4 hot roll channels metal lath	.75
Ceilings with 3/4 hot roll channels metal lath plastered	1.50
Single partition 3/4 channel lath 1 side	.85
Single partition 3/4 channel lath 2 sides 2 inches thick	1.50
4-inch double partition 3/4 channel lath 2 sides	1.30
4-inch double partition 3/4 channel lath 2 sides plastered	3.00

Plastering—Exterior—

2 coats cement finish, brick or concrete wall	\$1.00
2 coats Calaveras cement, brick or concrete wall	1.35
3 coats cement finish, No. 18 gauge wire mesh	1.75
3 coats Calaveras finish, No. 18 gauge wire mesh	1.50

Wood lath, \$7.50 to \$8.00 per 1000.	
2.5-lb. metal lath (dipped)	.17
2.5-lb. metal lath (galvanized)	.20
3.4-lb. metal lath (dipped)	.22
3.4-lb. metal lath (galvanized)	.28
3/4-inch hot roll channels, \$72 per ton	
Finish plaster, \$18.90 ton; in paper sacks.	
Dealer's commission, \$1.00 off above quotations. \$13.85 (rebate 10c sack).	
Lime, f.o.b. warehouse \$2.25 bbl.; cars, \$2.15	
Lime, bulk (ton 2000 lbs.), \$16.00 ton.	
Wall Board S ply, \$50.00 per M.	
Hydrate Lime, \$19.50 ton.	

Plasterers Wage Scale	\$1.25 per hour
Lathers Wage Scale	1.25 per hour
Hot Carriers Wage Scale	1.10 per hour
Composition Stucco—\$1.80 to \$2.00 sq. yard (applied).	

Plumbing—

From \$70.00 per fixture up, according to grade, quantity and runs.

Roofing—

"Standard" tar and gravel, \$6.50 per sq. for 30 sqs. or over.
 Less than 30 sqs, \$7.00 per sq.
 Tile, \$20.00 to \$35.00 per square.
 Redwood Shingles, \$7.50 per square in place.
 Copper, \$16.50 to \$18.00 per sq. in place.

Cedar Shingles, \$8.00 per sq. in place.
 Recoat, with Gravel, \$3.00 per sq.
 Asbestos Shingles, \$15 to \$25 per sq. laid.
 Slate, from \$25.00 to \$60.00 per sq. laid according to color and thickness.

Sheet Metal—

Windows—Metal, \$1.75 a sq. foot.
 Fire doors (average), including hardware \$1.75 per sq. ft.

S Skylights—(not glazed)

Copper, 90c sq. ft. (flat).
 Galvanized iron, 30c sq. ft. (flat).
 Vented hip skylights 60c sq. ft.

Steel—Structural

\$120 ton (erected), this quotation is an average for comparatively small quantities. Light truss work higher. Plain beams and column work in large quantities \$90 to \$100 per ton.

Steel Reinforcing—

\$80.00 to \$120.00 per ton, set.

Stone—

Granite, average, \$6.50 cu. foot in place.
 Sandstone, average Blue, \$4.00, Boise \$3.00 sq. ft. in place.
 Indiana Limestone, \$2.80 per sq. ft. in place.

Store Fronts—

Copper sash bars for store fronts, corner center and around sides, will average 75c per lineal foot.
 Note—Consult with agents.

Tile—Floor, Weinscot, etc.— (See Dealers)
 Asphalt Tile—18c to 28c per sq. ft. in stalled.

Venetian Blinds—

40c per square foot and up. Installatio extra.

THE BUILDERS' EXCHANGE OF SAN FRANCISCO STANDARD WAGE SCALE

For mechanics employed on construction work in the Bay Region. Effective September 1, 1937

CRAFT	Journeymen Mechanics	CRAFT	Journeymen Mechanics	CRAFT	Journeymen Mechanics
Asbestos Workers	\$ 8.00	Laborers, Building (8h-5d)	\$ 6.00	Steam Fitters (8h-5d)	\$11.00
Bricklayers (6h-5d)	10.50	Laborers, Common (8h-5d)	6.00	Stair Builders (8h-5d)	9.00
Bricklayers' Hodcarriers (6h-5d)	6.75	Lathers, Channel Iron (8h-5d)	9.00	Stone Cutters, Soft and Granite (8h-5d)	12.00
Cabinet Workers (Outside) (5d)	8.00	Lathers, All Others	9.00	Stone Setters, Soft and Granite	12.00
Caisson Workers (Open)	6.40	Marble Setters (8h-5d)	10.50	Stone Darrickmen	9.00
Carpenters (8h-5d)	10.00	Marble Setters' Helpers (8h-5d)	5.00	Tile Setters (8h-5d)	11.00
Cement Finishers (8h-5d)	10.00	Millwrights	9.00	Tile Setters' Helpers (8h-5d)	6.00
Cork Insulation Workers (8h-5d)	9.00	Model Makers (\$1.50 per hr-6h)	9.00	Tile, Cork and Rubber (8h-5d)	9.00
Electric Workers (8h-5d)	11.00	Modelers (\$2 per hr-6h)	12.00	Welders, Structural Steel Frame on Buildings	11.00
Electrical Fixture Hangers	8.00	Model Casters	7.20	Welders, All Others on Buildings	9.00
Elevator Constructors	10.40	Mosaic and Terrazzo Workers (Outside)	9.00	Dump Truck Drivers, 2 yards or less	6.00
Engineers, Portable & Hoisting	9.00	Painters (7h-5d)	8.50	Dump Truck Drivers, 3 yards	6.00
Glass Workers (8h-5d)	9.60	Painters, Varnishers and Polishers (Outside)	9.00	Dump Truck Drivers, 4 yards	7.00
Hardwood Floormen	9.00	Pile Drivers and Wharf Builders	9.00	Dump Truck Drivers, 5 yards	7.00
Housesmiths, Architectural Iron (Shop) (8h-5d)	9.00	Pile Drivers' Engineers	10.00	Dump Truck Drivers, 6 yards	7.00
Housesmiths, Architectural Iron (Outside) (8h-5d)	10.00	Plasterers (6h-5d)	10.00	Truck Drivers of Concrete Mixer Trucks: 2 yards or less	6.00
Housesmiths, Reinforced Concrete or Rodmen (8h-5d)	10.00	Plasterers' Hodcarriers (6h-5d)	7.50	3 yards	7.00
Iron Workers (Bridge and Structural) Including Engineers (8h-5d)	12.00	Plumbers (8h-5d)	11.00	4 yards	8.00
		Roofers, Composition (8h-5d)	9.00	5 yards	8.00
		Roofers, All Others (8h-5d)	8.00	6 yards	8.00
		Sheet Metal Workers (8h-5d)	10.00		
		Sprinkler Fitters	10.00		

GENERAL WORKING CONDITIONS

- Eight hours shall constitute a day's work for all crafts except as otherwise noted.
- Plasterers' Hodcarriers, Bricklayers' Hodcarriers, Roofers, Laborers, and Engineers, Portable and Hoisting, shall start 15 minutes before other workmen, both at morning and at noon.
- Five days, consisting of not more than eight hours a day, on Monday to Friday inclusive, shall constitute a week's work.
- Transportation costs in excess of twenty-five cents each way shall be paid by the contractor.
- Overtime shall be paid as follows: For the first four hours after the first eight hours, time and one-half. All time thereafter shall be paid double time, Saturdays (except Laborers), Sundays and holidays, from 12 midnight of the preceding day, shall be paid double time.
- On Saturday, Laborers shall be paid straight time for an eight-hour day.
- Where two shifts are worked in any twenty-four hours, shift time shall be straight time. Where three shifts are worked, eight hour's pay shall be paid for seven hours on the second and third shifts, allowing one-half hour for lunch.
- All work, except as noted in paragraph 9, shall be performed between the hours of 8 a.m. and 5 p.m.
- In emergencies, or where premises cannot be vacated until the close of business, men then reporting for work shall work at straight time. Any work performed on such jobs after midnight shall be paid time and one-half up to four hours of overtime and double time there after, provided, that if a new crew is employed on Saturdays, Sundays or holidays which he not worked during the five preceding days, such crew shall be paid time and one-half.
- Recognized holidays to be: New Year's Day, Decoration Day, Fourth of July, Labor Day, Admission Day, Thanksgiving Day, Christmas Day.
- Men ordered to report for work, for whom employment is provided, shall be entitled to two hours' pay.

MODERNIZED PRODUCTS

Brief Notes on New Materials and Equipment in the Building Industry.

32. CEDAR SHINGLES

The Red Cedar Shingle Bureau has issued a most interesting booklet or handbook on Red Cedar Shingles. It should be of more than considerable interest to all our readers. Send your copy.

33. ALUMINUM WINDOWS

Windows of Alcoa Aluminum is the title of a new brochure recently issued by The Aluminum Company of America. The coupon will bring you a copy of your files.

34. "BAKELITE"

Bakelite Corporation has put out a very fine little booklet called "Bakelite Laminated," which contains some pertinent data of interest to the building profession.

35. CORK COVERING

Armstrong Cork Products Company's new bulletin contains much useful information for the building profession. It is issued in the form of a wall news sheet. The coupon will bring you a copy.

36. WALL PRODUCT

"Transite Walls" by Johns-Manville, is the title of a broadside issued recently. Excellent illustrations and interesting reading matter relative to this important building material make this message to the reader who wishes to be informed on the progress of wall materials.

37. DAYLIGHTING

Barkon-Frink Tube Lighting Corporation have just put out a booklet which they titled Dayblended Lighting and use as a description "Bring the Sky Indoors with Dayblend." Send your copy of this illustrated booklet.

38. WALL VENTILATION

The Eckenroth Register Company have a new catalogue detailing their all season combination air conditioning wall registers." There is much interesting data and price lists contained.

39. PLYWOOD

"Harbordata" is the heading of a broadside put out by The Harbor Plywood Corporation, which describes their new and interesting product "Harborside," a fir and redwood siding. The coupon will bring a ready response and will insure your having all this information relative to the uses to which this siding may be put.

40. GLASS INSULATION

The Anaconda Wire and Cable Company announce another very interesting product in their recent broadside detailing "Vitrotex," a glass insulation for magnet wire.

41. REFRIGERATION

"Cold Selling Talk" is the title of a literature issued by The Westinghouse Electric and Manufacturing Company. It will be worth while to send in the coupon for your copy.

42. STREAMLINE PAINT

A new streamline paint called "Rezi-cote" is announced by I. F. Raucks, Inc., in a new descriptive booklet. This product comes in paste form and is used in the treatment of stucco, cement and brick.

43. TOWEL RACKS

The Holley Manufacturing Company have just issued a colorful catalogue illustrating their "pulls" towel racks, etc., in color to match other fixtures throughout a house. Send for your copy by using the coupon.

44. CINDERELLA WOOD

"Kraftwood," the modern Cinderella wood, is the title of a very beautifully arranged catalogue and brochure recently issued by the M and M Woodworking Company. The illustrations used in this brochure are striking and the whole set-up is interesting and should be seen to be appreciated.

45. MODERN HEATING

A most interesting booklet put out by the American Radiator Company called "A new kind of heating you've never seen before" should be of more than considerable interest to the home owner, as well as to the heating contractor and perchance the architect will find here something worthwhile.

46. ELECTRIC EYE

Teletouch Industries have issued a broadside and photographs of their new Teletouch Electric Eye Burglar Alarm. This is a new departure in burglar alarms. Send in the coupon for your copy and further information.

FREE FOR THE ASKING

Check items on coupon, paste on letter head or postal card, and mail to Architect and Engineer.

Architect and Engineer
68 Post Street
San Francisco, Calif.

Please send me literature on the following items as checked below. This request places me under no obligation.

- | | |
|-----------------------------|-----------------------------|
| 32 <input type="checkbox"/> | 39 <input type="checkbox"/> |
| 33 <input type="checkbox"/> | 40 <input type="checkbox"/> |
| 34 <input type="checkbox"/> | 41 <input type="checkbox"/> |
| 35 <input type="checkbox"/> | 42 <input type="checkbox"/> |
| 36 <input type="checkbox"/> | 43 <input type="checkbox"/> |
| 37 <input type="checkbox"/> | 44 <input type="checkbox"/> |
| 38 <input type="checkbox"/> | 45 <input type="checkbox"/> |
| | 46 <input type="checkbox"/> |

My Name.....

Name of Company.....

Street.....

City..... State.....

BIDS FOR GIANT SHASTA DAM

ONE of the largest construction jobs ever undertaken in California has been advertised for bidding by the United States Bureau of Reclamation which announced that bids for building giant Shasta Dam and power plant on the upper Sacramento River near Redding will be opened June 1, at the Central Valley Project office in Sacramento.

Shasta Dam will be the second largest concrete dam in the world, exceeded in height only by Boulder Dam on the Colorado River and exceeded in mass only by Grand Coulee under construction on the Columbia River. Boulder and Grand Coulee also are Bureau of Reclamation projects.

Commissioner of Reclamation John C. Page, in the official call for bids, announced the work will include excavating about 3,215,000 cubic yards of earth and rock to prepare a foundation for the dam; placing 5,610,000 cubic yards of concrete and 26,000,000 pounds of reinforcement steel in the dam and powerhouse; and installing 13,600,000 pounds of large penstock and outlet pipes, 8,000,000 pounds of small tubing for cooling and grouting, and 12,870,000 pounds of steel gates and control mechanisms.

Other items include over 1,600,000 cubic yards of rock and earth fills, 1,500,000 cubic feet of pressure grouting, 370,000 linear feet of metal sealing strips, 3,200,000 pounds of trashracks, 935,000 linear feet of electrical conduit and 166,000 linear feet of electrical cable.

A guarantee in the sum of \$2,000,000 will be required with each bid. The bidder to whom the contract is awarded will be required to post a performance bond of \$5,000,000, as well as a payment bond of \$2,500,000 to assure against default on labor and material bills.

The contractor, who must start work within 30 days after the Government gives official notice to proceed with construction, will be allowed 2,000 calendar days, or about 5½ years, to complete the job.

Walker R. Young, construction engineer of the Central Valley Project, said Shasta Dam will rise 560 feet from the lowest foundation to the top—higher than the tallest skyscrapers of San Francisco and Los Angeles—and will be about 3,400 feet, or almost two-thirds of a mile long on the crest. It will be 580 feet thick at the base.

The structure has been designed as a gravity-section concrete dam with a slightly curved axis. It will have a 375-foot overflow spillway in the center, 15 river-regulating outlets through the dam, and five 14-foot diameter penstocks leading to a 350,000-kilowatt power plant below the dam on the west bank of the river.

Shasta Dam will back up the waters of three rivers—the Sacramento, Pit and McCloud—a distance of 35

miles, to create a conservation reservoir with a storage capacity of 4,500,000 acre-feet which will be used for multiple benefits of improved irrigation, flood control, navigation, salinity repulsion and power generation.

NEW AIR CONDITIONING UNIT

A three-ton capacity, self-contained air conditioning unit designed especially for retail establishments and other commercial applications of average requirements, has been developed by Delco-Frigidaire Conditioning Division, General Motors Sales Corporation, and will be introduced nationally to supply the 1938 cooling season market.

Built in the air conditioning equipment manufacturing plant of General Motors in Dayton, the new unit provides cooling, dehumidification, filtering and air circulation. A heating coil may be added as optional equipment to provide year 'round utility, and provision may be made for ventilation by a simple duct connection.

Delco-Frigidaire anticipates a receptive market for the new unit in the retail field, since it has been designed to answer the needs of retail stores, apparel shops, offices, public rooms in hotels, restaurants and like operations.

Technically, the unit is as simple as its appearance.

Operating parts are enclosed in a compact cabinet. The cabinet is available in brown wrinkle finish, or may be refinished to match a specific plan of interior decoration.

Installation is extremely easy since the unit is entirely self-contained. All that is necessary is to move the unit in and make the necessary power, water and drain connections. The unit can be removed and reinstalled in a new location as a unit, with full salvage value. This is particularly desirable for installations on premises held on short term leases.

Aladdin Heating Corporation of Oakland are Delco-Frigidaire dealers.

C. P. FAREWELL

The many friends of C. P. Farewell, architects' representative for the Celotex Company in the San Francisco Bay Area, were saddened by news of his passing last month. An able representative of his company, Mr. Farewell was well known and liked by the architects and builders in his territory. No announcement has been made by the Celotex Company in regard to Mr. Farewell's successor.

MODESTO STORE BUILDING

Five stores, estimated to cost \$35,000, will be built at once at 13th and "J" Streets, Modesto, from plans by Russell G. DeLappe, architect, 1901 Downey Street, Modesto. The owners are Thomas C. Boone and R. E. Covell.

TEMPLE OF JEHOI (CHICAGO) COMING DOWN

THE striking reproduction of China's Golden Temple of Jehoi, one of the last remaining buildings of Chicago's Century of Progress Exposition, is being removed at last to make way for a landscaping project of the Works Progress Administration.

The picturesque Lama Temple, sole existing reproduction of the famous shrine in Northern China where the great Manchu emperors repaired to worship in the summers before the revolution of 1911, will not be demolished, however. It will be dismantled, carefully packed and stored away for future use.

Each of its 28,000 pieces of wood will be marked carefully for reassembly. When originally constructed, the directions for reassembly of the Temple were destroyed inadvertently and its erection was something in the nature of the working out of a gigantic jig-saw puzzle.

The site upon which it stood, and over which hundreds of thousands of visitors to the Exposition roved respectfully, visioning Lama monks turning prayer wheels in devout worship of their Buddha, is to be landscaped and beautified by the WPA in cooperation with local authorities who are beautifying the Lake Michigan waterfront.

No Chinese, save members of the royal family, were permitted to enter the original Golden pavilion of Jehoi, but in the two years of the Chicago Fair, 1,971,651 visitors paid \$217,709 to enter the exact replica erected at 16th Street and the Lake.

It was Sven Hedin, Swedish scientist and explorer, who conceived the idea of bringing such a temple to the Western World, and in 1929 the necessary financial backing was provided by Vincent Bendix, Chicago industrialist. The hunt for a suitable temple was commenced the same year.

"In inner Mongolia," Mr. Hedin said, "we examined a score of temples, but not one measured up to our demands. In 1930 we proceeded to Jehoi, the summer palace of the emperors, three days' journey north of Peking. There we came upon the object of our search, the perfect type of Chinese temple.

"It was standing on a high hill among thirty sacred buildings of Tibetan architecture. A wall with four gigantic towers was enclosing it, the holiest of Potala, the Golden Pavilion of Jehoi. It was a gem of Chinese art. In its lines, form, color and composition it was a masterpiece, of the highest order. There was not another like it in all China."

There was the temple, and all that remained was to move it to America. Which couldn't be done, because that particular gem was fixed too fast in its setting for any possibility of removal. Individual pieces crumbled when separated from the structure. Arrangements then were made for a faithful reproduction, and that, too, entailed a bit of ingenuity.

Ivory carvers prepared a model, seven feet square and six feet high, scaled to show just where each piece of wood was placed in the original. Chinese architects prepared the plans, skilled craftsmen shaped all the pieces except the heavy beams, columns and the roof, and several months later the unassembled Temple was shipped, in 173 crates, from Peking to Chicago.

A Chinese architect aided in erecting the Temple, a task retarded when it was found that the Chinese instructions on each packing case, meaningless to American workmen, had been destroyed. However, the building finally was joined and Chinese painters were brought to Chicago to make the final, exquisite decorations on the exterior and ceiling.

The receipts from the visitors to the Temple went directly into the Century of Progress treasury, the structure having been donated to the Exposition by its trustees, Mr. Bendix, Daniel H. Burnham and Yates Cassels.

The Temple will remain in storage until some one offers to take it over and maintain it as a museum. Mr. Burnham indicated there was a possibility it might be exhibited at the forthcoming New York World's Fair, if pending negotiations are successful.

Already in storage are the articles which graced the building's exterior. These are valued nominally at about \$300,000, but Mr. Burnham said many of them literally were priceless.

NEW CELOTEX OFFICIALS

The election of Henry W. Collins, New York, as a vice president of The Celotex Corporation, was recently announced by Bror G. Dahlberg, president of the company. The appointment of J. Z. Hollmann, Chicago, as general sales manager was also made public. In a third promotion, Harry W. Conway, New York, was appointed manager of the company's New York sales division, succeeding Mr. Collins in that post.

Mr. Collins will be in charge of merchandising with headquarters at Chicago, taking up his duties here May 1, Mr. Dahlberg stated.

Mr. Collins, thirty-five years of age, has been with The Celotex Corporation since 1923. Starting as a salesman on leaving Fordham University, he was appointed manager of the company's Chicago sales division early in 1927. He became New York sales division manager November 1, 1936. Married and the father of two children, Mr. Collins is at present a resident of Bronxville, New York.

Mr. Hollmann, forty-two years old, has been with The Celotex Corporation since 1926. Formerly branch manager of the St. Louis sales division, he was appointed assistant general sales manager November 1, 1936. A graduate of Washington State College, Pullman, Washington, he is married and has two children.

Mr. Conway, who succeeds to the post of New York sales division manager, was formerly assistant manager of that division.

U. S. PLANS SURVEY OF CALIFORNIA FLOOD AREAS

A comprehensive survey of California's recently flooded areas will be undertaken jointly by the State of California, the United States Army and the Department of the Interior, Secretary of the Interior Harold L. Ickes announced recently.

The survey, which will provide pertinent facts and figures for future flood control work as well as for the ordinary requirements of engineering and building projects of the Federal Government and the State of California, will be directed by the Geological Survey, Department of the Interior.

Reports from Geological Survey field engineers indicate that the storm and flood which inundated sections of Southern California in March, following closely on the heels of the December floods in the Central Valley and Northern California, were the most severe for that region for a period extending back at least to the year 1884. The Santa Ana River flood at San Bernardino was nearly twice as great as any earlier flood known there. That of the San Gabriel was 25 per cent greater than any of record, despite the two great dams now existing in its canyon, which greatly reduced the maximum flow.

The flood runoff from the five-day March storm filled Los Angeles County's fifteen flood-storage reservoirs, swept away old bridges, damaged the approaches to numerous modern bridges, and isolated the area for several days, causing, besides loss of life, property damage estimated to be well over \$50,000,000. Although final details for financing the entire flood survey project have not been completed, it is highly important that the work begin immediately with the portion of funds now available, Secretary Ickes said.

Each of the Federal agencies contributing to the survey has specific projects in the California area which require detailed flood data. The Bureau of Reclamation, Department of the Interior, which is contributing \$20,000 to the survey, has under construction the \$170,000,000 California Central Valley project designed to control floods, and navigation on the Sacramento and San Joaquin Rivers, provide supplemental irrigation water for about one and one-half million acres of land in the San Joaquin Valley and Suisun Bay areas, and supplement the domestic and industrial water supply in that region. Many of the details of design for this project, particularly for the storage reservoirs and intakes, are based on the continuous record of river flows in the area.

In addition to a \$10,000 contribution of funds and possible further financial aid from the State of California, it is expected that many local agencies of the State will co-operate in furnishing equipment and labor for the survey, and information for the final report.

Data obtained from the survey, in addition to supplying records of floods that are among the greatest floods in California's history, will supplement the con-

tinuous water records which have been compiled over a long period of years by the Geological Survey through its more than 280 gauging stations in the State. The December flood destroyed or seriously damaged twelve of these stations in the Great Valley while the March flood wrecked ten and seriously damaged at least twelve in the southern part of the State. Work of re-establishing them, at an estimated cost of \$55,000 will begin immediately in conjunction with the flood survey. The Corps of Engineers, United States Army, will repair those gauging stations which are located on streams upon which it is conducting activities relating to authorized flood control projects, contributing an estimated aggregate amount of \$12,500 to the work.

The information to be gathered will include: a detailed discussion of the weather conditions associated with the floods; records of flood heights and discharges at river measurement stations throughout the critical flood rises; flood discharges which will show the peaks for December and March, and dates and amounts of previous maxima, for comparison; crest stages of the floods at frequent intervals along all flooded streams; review of available information regarding previous notable floods with a view of making such information readily available for future use; general studies of the rainfall, run-off, and other features of the floods, with a view to providing a more exact knowledge of flood potentialities and adequate protective measures.

Compilation of the information will afford essential facts and figures for more economic location of highways, for the provision of adequate channel capacity and clearance at bridges, for the fixing of elevations for dams, intakes, canals and sewers.

AMBROSE J. RUSSELL

Tacoma lost a pioneer creator of artistic buildings in the death of Ambrose J. Russell, architect, who passed away, March 18, in his eightieth year. A member of the firm of Russell, Lance and Muri, Mr. Russell held honorary positions in both the Washington State Chapter, A.I.A., and the Tacoma Society of Architects.

Mr. Russell was born in India, October 15, 1875, his parents being Scottish missionaries. He received his advanced education and professional training at the University of Glasgow and the Ecole des Beaux Arts in Paris. He came to America in 1884, and worked for several years in Boston architects' offices.

Among the buildings in Tacoma which he designed are: The Masonic Temple, the Perkins Building, Christ Episcopal Church, Tacoma Country and Golf Club House, the Woodstock-Rutland and Earlham Court Apartment buildings, Washington National Guard Armory, Bishop Wells Hall of the Episcopal Church, Point Defiance Pavilion, and the Bridge Clinic. His largest single assignment was the design of the Standard Bank building in Vancouver, B. C.

LUXURIOUS COMFORT



NOW—WESIX BUILT-IN HEATERS

The new Wesix built-in electric heater is designed to give instant heat and luxurious comfort in the average size bathroom. It operates on the same principle as the world-famous Wesix portable heaters, with these advantages: the double action heating principle provides the desired amount of healthful infra-red rays and, at the same time circulates warm air at a normal velocity without fans or motors; the two-in-one heating chamber provides the highest known efficiency in electric heating; twin deflectors direct the heat flow away from the wall above the heater.

All Wesix heaters are fully and completely tested and approved by the Fire Underwriters' Laboratories and guaranteed for five years. The brilliant chromium finish of the Wesix "Built-In" harmonizes with any bathroom color scheme.

JOBS FOR DRAFTSMEN

A permanent employment bureau for architectural draftsmen has been established in Seattle by the U. of W. Architectural Alumni Association. Any architect desiring the services of a qualified draftsman may call at 1006 Securities Bldg., Seattle. The bureau registers applicants for drafting according to training, experience and special qualification.

Association officers elected to serve during the year 1938 are: President, Perry B. Johnson; secretary, Paul Carlson; vice-president, Robert L. Durham; treasurer, Waldo B. Christensen.

THE HOUSE THAT IS DESIGNED FOR LIVING

The architect's plans for this house include provision for **adequate** electrical wiring, because that is the basis of comfort and convenience for those who will live in it.

Adequate electrical wiring is the architect's concern because wiring is an integral part of the structure. It must provide plenty of outlets for appliances in use at present and new ones as they are acquired, as well as lighting.

If it does not, it will be a source of inconvenience and annoyance. If the building has to be rewired after it is completed, it will be much more expensive than if it had been done correctly in the first place.

Specify **RED SEAL** wiring in your plans, and be assured a sound foundation for adequate electrical convenience both now and for the future.

RED SEAL information, plans, and consultation without cost or obligation.

PACIFIC COAST ELECTRICAL BUREAU

SAN FRANCISCO • CALIFORNIA • LOS ANGELES
447 Sutter Street 601 W. 5th Street

LADDI DU-ALL BOILER-BURNER

... a compact and complete automatic unit furnishing hot water for medium sized apartments, heat or both heat and hot water for small and medium sized homes at low initial cost.

Designed and built in three sizes by the manufacturers of

JOHNSON OIL BURNERS

There's a JOHNSON Fuel Oil Burner for every purpose. Our engineers will assist in preparation of layouts and estimates.



Descriptive Bulletin on request

S. T. JOHNSON CO.

940 ARLINGTON AVENUE · OAKLAND, CALIFORNIA
401 NORTH BROAD ST., PHILADELPHIA, PA.

"Goods of the Woods"

Dependable Building Materials

Lumber and Millwork
for
All Types of Construction



Wolmanized or Creosoted
Lumber and Timbers
is your protection against
Termites and Decay



E. K. WOOD LUMBER CO.

San Francisco

Los Angeles

Oakland

LEAKING WIRES ARE COSTLY

By N. Stuart Irwin

LIKE pipes, wires leak when overloaded. They leak heat, lack power, lose money. Lights dim and dip, your refrigerator runs too long, and your iron heats so slowly and poorly it takes hours longer, when wires are too small.

Most homes were wired when electricity was intended only for lighting. These wiring systems are overloaded, inadequate and obsolete. They have to supply more light than was ever dreamed of, in addition to an appliance load which is sixty-seven percent heavier than they were intended for.

Fifty years ago, people thought food cooked by electricity was poison. Now, mixers, stoves, grills and griddles are as familiar as pots and pans in a modern kitchen. Electricity does everything from cooking a meal to giving a sun bath. And there is no reason why the next fifty years will not witness an even greater advance.

Overnight, the sales of water heaters, room coolers, and electric roasters have doubled. Twenty-eight million radios and eleven million refrigerators have been sold in less than ten years. All, creating demands for better wiring.

The reason for this increase is obvious. On a year's general average, 6½ cents runs a clock; \$18 protects food; \$3.50 does the ironing; \$1.31 does the washing; \$1.05 cleans the carpet; and \$4.38 buys entertainment. Electricity is the cheapest way of offsetting other higher costs.

Therefore, it is most imperative that wiring systems carry their intended load, without failure. And it is economically desirable that they permit expansion for additional loads as needs arise.

The new wires on the market today are plainly marked and measured as well as flame and moisture proof. At no additional cost it is possible to tell the name of the manufacturer, size, type and voltage, at a glance. Until now, buying was a matter of blind faith, for it was as hard to judge wires by their insulation as books by their covers. Today you can be sure your home is adequately wired, and that it will be livable, rentable, or salable.

For the cost of a piece of furniture you save in the preparation of food, laundering, cleaning, comfort, health and entertainment. Adequacy pays, pays for itself.

RESTAURANT ADDITION

A brick addition is planned to the restaurant building of E. Messina in San Jose, from drawings by Charles S. McKenzie, architect, Twohy Building, San Jose. Building will cover ground area 54 x 85 feet, and will be used as a banquet room.

BERKELEY RESIDENCE

Plans have been completed in the office of W. W. Wurster, architect in the Newhall Building, San Francisco, for a two-story frame residence to be built in Berkeley for Edward Glass.

ARCHITECTS VISIT COLUMBIA SQUARE

Columbia Broadcasting System's new home at 6111 Sunset Boulevard in Hollywood, Columbia Square, was the locale for the regular monthly meeting of Southern California Chapter, American Institute of Architects, May 2.

Attending the meeting was the designer of the building, William Lescaze of New York City. Mr. Lescaze spoke briefly on modern architecture, which he termed the architecture of our time; the use of materials available today, put together in a manner that will create a pleasing form.

According to Mr. Lescaze, the successful architect is bound to become more of an organizer, but one with an idea and the courage of his convictions. He stated that the local architects are the most lively and alert Chapter of the Institute.

Earl T. Heitschmidt, associate architect on the Columbia project, related experiences during the construction of the building and referred to his association with Mr. Lescaze as a liberal education. He introduced Paul O. Davis, who was his representative on the job and who handled all of the intricate detail.

Mr. Heitschmidt also introduced other men who were engaged in co-ordinating the work. They were: Ralph Phillips, associate mechanical and air conditioning engineer; S. B. Barnes, associate structural engineer; J. C. Edwards, vice-president of the William Simpson Construction Co., general contractors, and George S. Hoffmire, construction representative for Columbia.

D. W. Thornburgh, vice-president of Columbia Broadcasting System and general manager of Radio Station KNX, and John M. Dolph, assistant general manager of KNX, were introduced. Mr. Thornburgh stated that the buildings are wonderfully well designed from the standpoint of the use to which they will be put and, in his estimation, are convenient, comfortable and attractive.

Following the meeting the architects made a tour of the plant under the direction of guides regularly employed for that purpose. The studios, auditorium and sound effects department were visited, where explanations and demonstrations of the equipment were made.

A brief report on the Institute convention, held in New Orleans last month, was made by Eugene Weston, Jr., who presided at the meeting. He said the June meeting of the Chapter would be specifically of a business nature, when delegates to the convention would report on the apparent trend of the Institute nationally.

The delegates were: Carleton M. Winslow, Earl T. Heitschmidt, Harbin Hunter, A. M. Edelman, Sumner Spaulding, Eugene Weston, Jr., and Edgar F. Bissantz. Charles A. Hunter and William Schuchardt attended the convention in a non-official capacity.

STOCKTON STORE BUILDING

J. H. Cloudsley and Eric Johnson, Exchange Building, Stockton, are preparing plans for a one-story and mezzanine brick and concrete store building in Stockton for an unnamed client.

No Worry for the Architect

"—All acid proof drain pipe and fittings shall be ferro-silicon—CORROSIRON—"

The architect who writes this in his specifications solves at once his problem of overcoming corrosion.

[Write for this specification]



FEDERAL BUILDING • CIVIC CENTER • SAN FRANCISCO

Arthur Brown, Jr., Architect

CORROSIRON DRAIN LINES and FITTINGS and LABORATORY EQUIPMENT was specified because of its superior resistance to corrosion and wear.

Pacific Foundry Company, Ltd.

NEW YORK • 3100 NINETEENTH ST., SAN FRANCISCO • LOS ANGELES

BUILD WELL~

A PROPERLY designed and well constructed building is a credit to any city and a profitable investment for its owner.

Such structures are the STAND-ARD OIL BUILDING, MATSON BUILDING, FOUR-FIFTY SUT-TER STREET, STOCK EXCHANGE, S. F. BASE BALL PARK, MILLS TOWER, OPERA HOUSE and VETERANS' MEMORIAL, San Francisco, OLYMPIC CLUB AL-TERATIONS, SANTA ANITA RAC-ING PLANT and other notable structures — all built or super-vised by —

Lindgren & Swinerton, Inc.

Standard Oil Building
San Francisco

605 W. Tenth Street
Los Angeles

We Maintain a Termite Control Department



"Color - Pulls"

Durable Plastic - Ultra Modern
Wide variety of Color Combinations
Drawer Pulls - Knobs - Towel Racks



Literature on Request

HOLLEY MANUFACTURING COMPANY

912 S. E. HAWTHORNE BOULEVARD

PORTLAND, OREGON



Write for "The Charm of a Well Lighted Home" — to help you plan attractive healthful lighting.

Plan your lighting when you're planning. Incandescent provides ideas for any decorative effect in beautiful traditional and contemporary Lightoliers wrought for a lifetime of perfect lighting.

INCANDESCENT SUPPLY CO.

SAN FRANCISCO : OAKLAND : FRESNO : LOS ANGELES

The better homes of today are
AIR CONDITIONED
for year-round weather

Consult us for the answer to your problems

MANUFACTURERS



OIL FIRED FURNACES
GAS FIRED FURNACES
SHEET METAL PRODUCTS

Harer - Perry Company

5662 Keith Ave., Oakland, Cal.
Phone HUmboldt 7928

A Permanent Exposition
of the newest ideas
in home planning
and equipment.



THE BUILDING MATERIAL EXHIBIT

Architects Bldg. • Fifth & Figueroa • Los Angeles • MU-6306

INCLUDE TREES IN YOUR PLANS

DAVEY, ORIGINATOR OF TREE SURGERY, OFFERS FREE INSPECTION AND ESTIMATE.



SAN FRANCISCO Russ Bldg. SUTter 3377
Fresno Mattei Bldg. TUCKer 1929
LOS ANGELES Story Bldg. TUCKer 1929

Local phones in: Pasadena, Palo Alto, Oakland, San Rafael, San Mateo

SKILL - KNOWLEDGE - RESPONSIBILITY

STRUCTURAL STEEL

For Class A Buildings,
Bridges, etc.

JUDSON PACIFIC CO.

609 MISSION STREET
SAN FRANCISCO

Plants: San Francisco - Oakland

USE BASALITE

Light-weight, pre-fabricated Concrete building products for floors, walls, and roofs in your next building.

BASALT ROCK COMPANY, INC.

Napa, California

NOISE Control

Office Quieting
Sound-proof Partitions
Acoustical Correction

WESTERN ASBESTOS CO.

Building Materiall Mechanical Specialist
SACRAMENTO OAKLAND
SAN FRANCISCO

MULLEN MFG. COMPANY

BANK, STORE AND OFFICE
FIXTURES—CABINET WORK
OF GUARANTEED QUALITY
CHURCH SEATING

Office and Factory:
60-80 RAUSCH ST., Bet. 7th and 8th Sts.
San Francisco
Telephone UNDERhill 5815

OVER NIGHT OR JUST A MEAL



SANTA MARIA INN

FRANK J. McCoy, Manager

On the Coast Highway, midway between
San Francisco and Los Angeles

SPECIFY

DUTCH BOY

Painter Products

BASS - HUETER

Paints and Varnishes

NATIONAL LEAD COMPANY

San Francisco Seattle
Portland Los Angeles

Branches and dealers in all principal cities

G. P. W.

JENSEN & SON

Building Construction

320 Market Street, San Francisco

Phone: GARfield 2444

WINNERS OF STEEL COMPETITION

Elevated highways to relieve congestion and to speed the flow of traffic through densely populated cities can be designed not only economically but aesthetically. This was proved by the 273 designs submitted in the competition just held by the American Institute of Steel Construction.

The first prize of \$5,000 goes to Hazelet & Erdal, consulting engineers, of Chicago, Ill. Theirs was a streamlined design supporting a four-lane roadway upon a cantilevered floor beam supported on a central bent the spread of the legs of which is sufficiently close not to impinge upon, but forms a center safety zone upon the street below. Mr. Hazelet is a graduate of the University of Washington, and of Massachusetts Institute of Technology.

The second prize of \$2,000 was awarded to Madigan-Hyland, consulting engineers of New York—E. H. Praeger, Chief Engineer and C. F. Lloyd, Architectural Designer. The design they submitted was that actually built for that portion of the new Henry Hudson Parkway, between St. Clair Place and 13th Street, New York.

The third prize of \$1,000 was given to Walter W. W. Jones, a civil service employee with the title of Engineering Illustrative Designer, Department of Borough Works, Borough of Manhattan.

RADIANT HEAT

Under a new technical advisory committee set up by the Committee on Research of the American Society of Heating and Ventilating Engineers, a coordinated study of the effects of radiant heat on human comfort and its economic value as compared to convected heat, will be undertaken on a broad scale, according to an announcement by W. L. Fleisher, chairman of the Society's general research committee.

The new committee, headed by J. C. Fitts, executive secretary of the Heating, Piping and Air Conditioning Contractors' National Association, proposes to assemble and coordinate existing data with a view to defining more easily the physiological aspects of supplying more or less heat to the

HOTEL L'AREMONT



20 Acres
of Park

Enjoy...

... all the benefits of a
country estate in town.

Tennis, riding, golf, dancing, quiet nights to insure sound sleep. Excellent meals at moderate family prices. Large outside rooms with bath \$2.00 and \$2.50. Ideal location overlooking Golden Gate, convenient to all Bay cities. Write today for descriptive booklet.

BERKELEY California

OFFICE FURNITURE
MODERATE PRICES
LIBERAL BUDGET TERMS

H. S. CROCKER COMPANY, Inc.

565 Market St. 260 Montgomery St.
SAN FRANCISCO

Robert W. Hunt Company ENGINEERS

Inspection - Tests - Consultation
Schools and Other Structures
Are Built as Designed

When Construction Materials are
Inspected at point of Manufacture
and during Erection by

ROBERT W. HUNT COMPANY

Cement, Concrete, Chemical, Metallurgical,
X-Ray and Physical Laboratories

Chicago - New York - Pittsburgh
Los Angeles - All Large Cities
San Francisco, 251 Kearny Street



No longer a problem
for the Architect

TRANSIT MIX CONCRETE AND MORTAR

makes delivery of material to the job swift and inexpensive . . . minimizing the architect's supervision costs and assuring his client a dependable mix.

Speed . . . Reliability . . . Economy
Let us co-operate with you

Golden Gate-Atlas Materials Co.

16th and Harrison Streets
San Francisco
UNderhill 3650



Model No. 80 "Capitol"

It's flush with the wall

This completely recessed HAWS sanitary drinking fountain, made of vitreous china in colors to suit, offers the architect a flush-to-the-wall fixture that is modern in design . . . good looking . . . attractively priced.

Made by

HAWS DRINKING FAUCET CO.

1808 Harmon Street Berkeley

Send for New Catalog "R"

body by direct radiation and to determine the degree and range of comfort experienced by persons subject to radiant heat. The committee will also be concerned with interpreting research laboratory data resulting from studies made at Yale under Professor C. E. A. Winslow and at the University of Cincinnati under Dr. C. A. Mills and others. Broad objective is to supplement previous research in comfort air conditioning with similar studies on radiant heat.

BENEFITS PLUMBING INDUSTRY

Realization of the potential business to be developed under the Property Improvement Credit Plan of the National Housing Act amendments of 1938 is rapidly being crystallized by the aggressive plumbing and heating industry—pioneers in modernization work under the FHA plan.

Between August 13, 1934, when the plumbing and heating industry secured the first modernization job under the old Modernization Credit Plan, and the day that it expired, April 1, 1937, more than half a billion dollars of business developed. The significant fact underlying these figures, however, is that the plumbing and heating industry gained about a quarter of the total business. This is doubtlessly responsible for the enthusiastic reception with which the industry has received the restored Property Improvement Credit Plan.

While it is virtually impossible to estimate the amount of work currently being done by plumbing and heating engineers, in that lending agencies have thirty days in which to report these loans to FHA, it is evident that the industry is again receiving a large share of the business. One indication of the extent to which the plumbing and heating industry is participating in the program can be found in the announcement of a spokesman for a large heating company, who declared that one day's mail brought 2,700 applications from dealers for modernization loan blanks, constituting "a response which is without parallel in our experience."

HIGH FIRED

Kraftile

THE TERRA COTTA WITH THE 10 ADVANTAGES

Master Kraftile...Terra Cotta Wall Units...Ceramic Facings...Cutting Machines...Swimming Pool Ladder Steps...Swimming Pool Overflow Hand Rails...Bathroom Accessories...Enameled Brick...Special Shapes

See Success Architectural Catalog, No. 11-5, Section 11, Fifth Catalog

KRAFTILE COMPANY
NILES - CALIFORNIA
(San Francisco Bay Area)



MERCURY DRESS

We Print
The ARCHITECT and
ENGINEER

"A Thing of Beauty
Is a Joy Forever"

942 HOWARD STREET
SAN FRANCISCO

SISALKRAFT

REG. U. S. PAT. OFF.

"More than a
building paper"

THE SISALKRAFT CO.

205 West Wacker Drive
(Canal Station) Chicago, Ill.
55 New Montgomery Street
San Francisco, Calif.

Pacific Manufacturing Company

High Class Interior Finish
Quality Millwork

454 Montgomery St. 6820 McKinley Ave.
San Francisco Los Angeles
GARfield 7755 THORNwall 4196

1315 Seventh Street, Oakland
GLEncourt 7850

Here's the last word IN BATHROOM HEATING



The WESIX "49er"!

Every new home should have one.
List price, only \$21.50
For catalog sheet and specifications
write to

1018 Wesix Building
San Francisco, California

WESIX

ELECTRIC HEATER CO.

PULSE OF THE READER

(Concluded from Page 8)

years. We believe that by the passage of these bills a step has been taken in the right direction, and also that you have selected the man best fitted for the position as Administrator of the United States Housing Authority. Briefly, we are firm and enthusiastic supporters of both these legislative acts. However, we believe that Senate Bill 1685 should be amended and our reasons for the same are as follows:

It would cost twenty billion dollars to clear the slums in the United States. There has been voted in the above bill, (S-1685) one-fortieth of this amount. Even if the full amount of twenty billion had been voted, there are too many obstacles to overcome in order to clear and rebuild the entire slum districts in the United States. It would seem to us that the first objective should be to build the fifteen million houses that we need at the present time and also to care for the annual demand of over one and one-half million new homes.

Your bill provides for "the elimination by demolition, condemnation, and effective closing, or the compulsory repair or improvement of unsafe or insanitary dwellings situated in the locality or metropolitan area, substantially equal in number to the number of newly constructed dwelling units provided by the project . . ."

It seems to us that this provision is absolutely impossible, and that you would only further congest the existing slum and blighted districts. The proposition of postponing the demolition of existing buildings would never be consummated inasmuch as it will be many years before we have sufficient homes built to cover the existing shortage and also the one and one-half million new homes which are needed annually. This annual demand has not been met at any time. Therefore there exist old, worn-out houses that should have been destroyed long ago. However, people do have to have shelter, and at the prevailing rates they can only afford possibly one or two rooms, which is insufficient space for an average family. Concerning the greater part of the United States, it seems to us that we will have to enter into an extensive campaign of building single family dwellings.

In the photostatic copies which we sent you, the four family dwellings (illustrated in The Architect and Engineer for April) can be built and rented in the State of California at the following prices, including house, garage, five hundred dollar lot, landscaping—all complete ready for occupancy—financed on a 3½ per cent basis and amortized over a period of 40 years.

Model "A" Home \$15.00 per month
Model "B" and "C"

Homes \$16.50 per month
Model "D" Home about \$18.00 per month

We believe that the same space in any slum clearance project would cost and rent for twice this amount. By building single family houses you could build two homes for the same price for which one home could be built in a slum clearance project.

Some of the cities complain about the tax exemption clause. It is an admitted fact that those persons owning property outside of the slum districts are paying 90 per cent of the charges for health, police, fire, delinquency, and crime, for the slum districts. The well built home where the children have air space, sun-

ABBOT A. HANKS, INC. Engineers & Chemists

INSPECTING — TESTING — CONSULTING
CONCRETE • STEEL • MATERIALS
CHEMICAL AND TESTING
LABORATORIES
• RESEARCH AND INVESTIGATION •

TESTS OF STRUCTURAL MATERIALS
DESIGN OF CONCRETE MIXES
SHOP AND ERECTION INSPECTION OF
STRUCTURES AND EQUIPMENT
INVESTIGATION OF STRUCTURES
AND MATERIALS
TESTS AND INVESTIGATION OF
FOUNDATION SOILS
FIRE RESISTANCE AND INSULATION
TESTS

624 Sacramento Street, San Francisco

VAUGHN - G. E. WITT Co.

Manufacturers and Distributors

Pump Governors	Oil Heaters
Safety Pump Governors	Relief Valves
Automatic Gas Regulating Valves	Oil Burner Governors
Gas Burning Equipment	Oil Burners
Vacuum Pump Governors	Oil Pumping Sets
Vacuum Regulating Valves	Oil Valves
Continuous Flow Steam Traps	Oil and Steam Strainers
Thermostats	Duplex Oil Pumps
Reducing Valves	Rotary Oil Pumps
	Boiler Feed Pumps
	Water Heaters
	Boiler Feed-Water Regulators

4224-26 Hollis St., Emeryville, Oakland



HERRICK IRON WORKS

STRUCTURAL STEEL

18TH AND CAMPBELL STS.
OAKLAND, CALIF.

Phone GLencourt 1767

FORDERER Cornice Works

Manufacturers of

Hollow Metal Products
Interior Metal Trim
Elevator Fronts and Cabs
Metal Wall Plugs, Anchors, Etc.
Sheet Metal Products
Sanitary Metal Base
Commercial Refrigerators
Building Paper
Metal and Wire Accessories
for Concrete

269 POTRERO AVENUE
San Francisco, Calif.

HEmlock 4100
CONSULT OUR ENGINEERING
DEPARTMENT

PAN-AMERICAN (Simplex)



Model 12

AUTOMATIC OIL BURNER

The model illustrated is the smallest of many sizes and types of oil burners built by

PAN - AMERICAN ENGINEERING CO.

820 Parker Street • Berkeley

Phone BErkeley 6755

BEAUTY CLEANLINESS DURABILITY

All three combined
in one material —

FERRO-PORCELAIN

Exteriors of build-
ings, interiors of rest
rooms, kitchens and
bathrooms are all
logical places for
this material.

Inquiries promptly answered

FERRO ENAMELING CO.

1100 - 57th Ave., Oakland, Calif.

Independent Iron Works

Structural Steel
Ornamental Iron
Steel Service Stations
Steel Tanks
Standard Steel Mill Buildings
Bridges

821 Pine Street

Oakland

Clinton Construction Co.

of California

*General
Contractors*

923 Folsom Street
San Francisco
SUtter 3440

shine, flowers and gardens, would elimi-
nate a very large percentage of this tax
burden.

The realtor feels that he is left out in
the cold. This is not true. The realtor
never has, does not now, and never will
sell 65 per cent of our people's real
estate. On the contrary, as if and when a
real building program is put into effect
to take care of these persons in the lower
brackets of income, it will create new
business entirely, by which the realtor, the
material men, and the butcher, baker and
candle-stick maker would profit.

In closing may we suggest that this bill
be amended to call for a five billion dol-
lar bond issue by the United States Gov-
ernment for housing the people as set
forth in the Wagner-Steagall Bill, elimi-
nating all the stumbling blocks except
that no person will be eligible to rent
one of these homes if their income is over
five times the rent and charges for light,
gas, water, and heat.

By doing this we would not only de-
crease our costs for crime, delinquency,
health, police, fire, and other services
rendered, but we would build up the
morale of our people to an extent hither-
to unknown. We would stimulate business
activities, decrease unemployment, and
become real humanitarians. We have no
right to claim that we are a civilized peo-
ple when we allow that vast multitude of
human beings to live in dirt, filth, and
squalor.

As we have repeatedly stated, the build-
ing of low cost homes will be the greatest
economic adventure ever known. If Con-
gress and the President would get squarely
behind this five billion dollar housing
program we believe that it would greatly
assist in eliminating the present business
recession.

Pitcher

Improved
Disappearing Doors
Save 20% Space

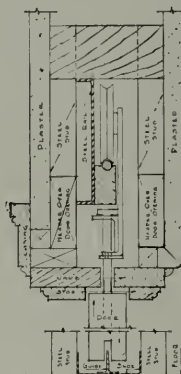

Joins with a
4" stud
wall...
steel
studs...
adjustable
steel and
wood track.
Can be
used for
screen
doors in
connection
with
French
doors; also
to close
arches.
Send for
detail
drawing

E. C. Pitcher Co.

461 Market Street
San Francisco

ROLL-AWAY

OF BERKELEY

WINDOW SCREENS

HAVE NO
E Q U A L

A specification leaving no oppor-
tunity for substitution . . . will be
permanently appreciated by
every client.

ROLL-AWAY WINDOW SCREEN COMPANY

8TH & CARLTON STS., BERKELEY, CALIF.
SAN FRANCISCO 557 MARKET ST.
LOS ANGELES 169 N. LA BREA

ANDERSON & RINGROSE

General Contractors

320 Market Street, San Francisco
Phone GARfield 2245

HIGH GRADE MILLWORK
AND INTERIOR FINISH
SASH AND DOORS

LANNOM BROS. MFG. CO.

FIFTH AND MAGNOLIA STREETS
OAKLAND, CALIFORNIA
Telephone: LAKeside 3663

Phone GARfield 1164

Hunter & Hudson

Consulting Engineers
DESIGNERS OF HEATING
AIR CONDITIONING
VENTILATING AND WIRING
SYSTEMS, MECHANICAL
AND ELECTRICAL EQUIP-
MENT OF BUILDINGS

41 SUTTER STREET
ROOM 710
San Francisco California

"AMERICAN MARSH" Redi-Vac Vacuum Heating Pump

Send for
Bulletin 441

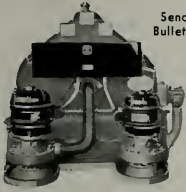

SIMONDS MACHINERY CO.
San Francisco Los Angeles
816 FOLSOM ST. 522 EAST 4TH ST.

DINWIDDIE CONSTRUCTION COMPANY

BUILDERS OF
GOOD BUILDINGS

CROCKER BUILDING
SAN FRANCISCO

Carl T. Doell Co.

*Plumbing
Heating*

Plumbing Contractor
Veterans Memorial Building
Oakland

467 21ST STREET
OAKLAND

Telephone GLencourt 8246

Another Monument
to

DUNNE PRIMER SEALER and DUNNE SATIN WALL

The Best For
Looks - Protection - Economy

Inspect the
Alameda County Court House

FRANK W. DUNNE CO.
41st and Linden Sts. Oakland, Calif.
MAKERS OF GOOD PAINT

REPUBLIC STEEL CORPORATION



Manufacturers of

ENDURO Stainless Steel; TON-
CAN Copper Molybdenum Iron
Sheets and Pipe; and Steel Pipe,
Sheets and Reinforcing Bar for
every building purpose.

Write for information

Rialto Building, San Francisco, Calif.
Edison Building, Los Angeles, Calif.
White-Henry-Stuart Bldg., Seattle, Wash.

JOHN CASSARETTO

—Since 1886—And Still Active—

Building Materials

READY MIX CONCRETE
ROCK - SAND - GRAVEL - LIME
CEMENT - PLASTER - MORTAR
METAL LATH - WOOD LATH
STUCCO - WIRE NETTING

Service Unexcelled

Bunkers
Sixth and Channel, San Francisco
Phones: GARfield 3176, GARfield 3177

THE TORMEY COMPANY

GENERAL PAINTERS
AND DECORATORS

Phone UNDERhill 1913

563 FULTON STREET
San Francisco

COMFORT

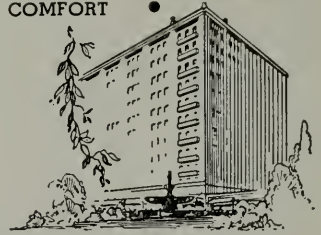

New HOTEL CLARK

in Downtown
LOS ANGELES

Convenience is another altering of
this hotel. Whether on business or
pleasure bent, the Hotel Clark
makes an ideal "base of operations,"
as well as a restful "billet" at the
end of the day's "campaign." Good
Food, naturally. And moderate
charges, as well as for room accom-
modations, give final significance
to assuring word — COMFORT

Single from \$2.50
Double from \$3.50

ROOMS
555
BATHS

Fifth and Hill

P. G. B. MORRIS, Manager

Smith

Lumber Company

WHOLESALE - JOBBING - RETAIL
FACTORY AND BUILDING LUMBER
PLYWOODS - ROOFING

DISTRIBUTING YARDS

San Francisco | Oakland
4th & Channel | 19th Ave. &
Market 0103 | Estuary
FRUITVALE 3174

YOUR INQUIRIES SOLICITED

JOSEPH MUSTO SONS-KEENAN COMPANY

MARBLE
and
ONYX

535 NORTH POINT STREET
SAN FRANCISCO
1801 S. SOTO STREET
LOS ANGELES

“The Selling Punch”

In the boxing game they call it “the one-two.” We certainly don’t infer you should go out and punch your prospect on the nose (even though you might feel like it some times after he has given the business to your competitor). What we want to call your attention to is the doubly effective complete advertising-selling plan offered by THE ARCHITECT AND ENGINEER and ARCHITECTS REPORTS.

- **Make it easy for your prospect to buy or specify your product**

A series of advertisements in THE ARCHITECT AND ENGINEER will serve to familiarize the architects, contractors, engineers, owners whom you aim to sell, with the advantages of your product . . . break down resistance . . . arouse interest . . . impel favorable action.

- **Follow up your advantage at the right time**

ARCHITECTS REPORTS will tell you when to intensify your efforts with the right man, when he is in position to place new business . . . by reporting building projects of every description, from the earliest stages of development to the awarding of the last sub-contract.

Other producers and marketers of building supplies (including in all probability your competitors) are *profitably* utilizing one or both of these selling forces. Why not fortify *your* business-getting efforts with this “Selling Punch”?



The ARCHITECT and ENGINEER

Architects Reports

68 POST STREET • SAN FRANCISCO

“*Thirty-second Year of Continuous Publication*”

ARCHITECTS' AND ENGINEERS' SPECIFICATION INDEX

Classified Directory of Building Material Manufacturers, Dealers and Contractors

*Denotes subscriber of ARCHITECTS' REPORTS, sponsored and endorsed by State Association of California Architects, and published daily by THE ARCHITECT AND ENGINEER.

ACOUSTICAL AND SOUND CONTROL
ARMSTRONG CORK PRODUCTS Co., 1355 Market Street, San Francisco.

*JOHNS-MANVILLE Sales Corp., 116 New Montgomery Street, San Francisco.

WESTERN ASBESTOS Co., 675 Townsend Street, San Francisco.

CRAMER Co., 50 Howard Street, San Francisco.

TURNER RESILIENT FLOORS, Inc., 141 New Montgomery Street, San Francisco.

CELOTEX Corp., 675 Townsend Street, San Francisco.

AIR CONDITIONING

S. T. JOHNSON Company, 940 Arlington, Oakland.

*ELECTRIC APPLIANCES, Inc., 2001 Van Ness Avenue, San Francisco.

*ALADDIN HEATING Corporation, 5107 Broadway, Oakland.

*FRANK EDWARDS Co. (General Electric), 930 Van Ness Avenue, San Francisco.

GENERAL Air Conditioning & Heating Company, 4001 Piedmont Avenue, Oakland.

ARCHITECTURAL METAL SUPPLIES

*BRAUN-STEEPLE Co., 636 Potrero Ave., San Francisco.

ARCHITECTURAL TERRA COTTA

N. CLARK & SONS, 116 Natoma Street, San Francisco.

GLADDING McBEAN & Co., 9th and Harrison Streets, San Francisco; 2901 Los Feliz Boulevard, Los Angeles; 1500 First Avenue South, Seattle; 79 S. E. Taylor Street, Portland; 22nd and Market Streets, Oakland; 1101 N. Monroe Street, Spokane; Vancouver, B.C.

KRAFTILE COMPANY, Niles, California, and 525 Market Street, San Francisco.

BATHROOM HEATERS

WESIX ELECTRIC Heater Company, 390 First Street, San Francisco; 631 San Julian Street, Los Angeles; 2008 Third Avenue, Seattle, Wash.

BLINDS—VENETIAN

GUNN-CARLE & Co., 20 Potrero Avenue, San Francisco.

*H. E. ROOT, 1865 California Street, San Francisco.

*RY-LOCK Co., 1355 Market Street, San Francisco.

BOILERS AND PIPE

*C. C. MOORE & Company, 450 Mission Street, San Francisco.

BRICK—FACE, COMMON, ETC.

N. CLARK & SONS, 116 Natoma Street, San Francisco.

GLADDING McBEAN & Co., 9th and Harrison Streets, San Francisco; 2901 Los Feliz Boulevard, Los Angeles; 1500 First Avenue South, Seattle; 79 S.E. Taylor Street, Portland; 22nd and Market Streets, Oakland; 1102 N. Monroe Street, Spokane; Vancouver, B.C.

BRASS

AMERICAN BRASS Co., Russ Building, San Francisco.

BUILDERS HARDWARE

THE STANLEY WORKS, New Britain, Conn.; Monadnock Bldg., San Francisco; Los Angeles and Seattle.

*SCHLAGE LOCK Co., 20 Blanken Avenue, San Francisco.

*FARMER'S UNION, 151 W. Santa Clara Street, San Jose.

*MAXWELL HARDWARE Company, 1320 Washington Street, Oakland.

*P. and F. CORBIN, New Britain, Conn.

BUILDING MATERIALS

BUILDING MATERIAL EXHIBIT, Architect's Building, Los Angeles.

*CONTRA COSTA BUILDING MATERIALS Company, 2824 Shattuck Ave., Berkeley.

*MISSION BUILDING MATERIALS Co., Millbrae, Calif.

*RHODES & KENNEDY, 101 4th Street, Oakland.

BUILDING PAPERS

THE SISALKRAFT Company, 205 W. Wacker Drive, Chicago, Ill., and 55 New Montgomery Street, San Francisco.

BUILDING PRODUCTS

"BASALITE," a lightweight, pre-fabricated material for floors, walls and roofs—Basalt Rock Co., Inc., Napa, California.

CABINET WORK

*FINK and SCHINDLER, 552 Brannan Street, San Francisco.

MULLEN MANUFACTURING Co., 64 Rausch Street, San Francisco.

*MODERN FUTURE & Cabinet Co., 59 Oak Grove Street, San Francisco.

CEMENT

*CALAVERAS CEMENT Company, 315 Montgomery Street, San Francisco.

PORTLAND CEMENT Association 564 Market Street, San Francisco; 816 West Fifth Street, Los Angeles; 146 West Fifth Street, Portland; 518 Exchange Building, Seattle.

"GOLDEN GATE" and "OLD MISSION" manufactured by Pacific Portland Cement Co., 111 Sutter Street, San Francisco; Portland, Los Angeles and San Diego.

*HENRY COWELL Lime & Cement Company, 2 Market Street, San Francisco.

*SANTA CRUZ PORTLAND Cement Company, Crocker Building, San Francisco.

CEMENT—COLOR

"GOLDEN GATE TAN CEMENT" manufactured by Pacific Portland Cement Co., 111 Sutter Street, San Francisco; Portland, Los Angeles and San Diego.

CEMENT PAINT

FRANK W. DUNNE Company, 41st and Linden Streets, Oakland.

CHEMICAL ENGINEERS

ABBOT A. HANKS, Inc., 624 Sacramento Street, San Francisco.

ROBERT W. HUNT, 251 Kearny Street, San Francisco.

CLAY PRODUCTS

GLADDING McBEAN & Company, San Francisco, Los Angeles, Portland and Seattle.

N. CLARK & SON, San Francisco and Los Angeles.

KRAFTILE Company, Niles, California, and 525 Market St., San Francisco.

*GLADDING BROS. Mfg. Co., San Jose.

CLOCKS—ELECTRIC TIME

*INTERNATIONAL BUSINESS Machines Corp., 25 Battery Street, San Francisco.

CONCRETE AGGREGATES

GOLDEN GATE ATLAS Material Company, Sixteenth and Harrison Streets, San Francisco.

JOHN CASSARETTO, Sixth and Channel Streets, San Francisco.

*TRANSIT CONCRETE, Inc., 2500 Peralta Street, Oakland.

CONCRETE CURING & PROTECTION

THE SISALKRAFT Company, 205 W. Wacker Drive, Chicago, Ill., and 55 New Montgomery Street, San Francisco.

CONTRACTORS—GENERAL

LINDGREN & SWINERTON, Inc., Standard Oil Building, San Francisco.

DINWIDDIE CONSTRUCTION Co., Crocker Building, San Francisco.

CLINTON CONSTRUCTION Company, 923 Folsom Street, San Francisco.

ANDERSON & RINGROSE, 320 Market Street, San Francisco.

G. P. W. JENSEN, 320 Market Street, San Francisco.

*GEO. ARTHUR & SON, 941 So. Claremont Street, San Mateo.

*A. T. BECKETT, 224 Scenic Avenue, Piedmont.

*L. M. G. PETERSON, 520 Bowdoin Street, Palo Alto.

*BARRETT & HILP, 918 Harrison Street, San Francisco.

DAMP-PROOFING & WATERPROOFING

"GOLDEN GATE TAN PLASTIC Water-proof Cement," manufactured by Pacific Portland Cement Co., 111 Sutter Street, San Francisco; Portland, Los Angeles and San Diego.

DOOR HANGERS

PITCHER'S SLIDING DOOR HANGERS, Sheldon Building, San Francisco.

DOORS—HOLLOW METAL

FORDERER CORNICE Works, Potrero Avenue, San Francisco.

KAWNEER Mfg. Co., Eighth Street and Dwight Way, Berkeley.

ACID PROOF DRAIN PIPE

CORROSION—Acid resisting pipe, fittings exhaust fans, pumps, etc., Pacific Foundry Co., 3100 19th Street, San Francisco; 1400 S. Alameda Street, Los Angeles.

DRINKING FOUNTAINS

HAWS DRINKING FAUCET Co., 1808 Harmon Street, Berkeley; American Seating Co., San Francisco, Los Angeles and Phoenix.

ELECTRIC ADVICE

PACIFIC COAST ELECTRICAL Bureau, 447 Sutter Street, San Francisco, and 601 W. Fifth Street, Los Angeles.

ELECTRIC FIXTURES

*THE FRINK Corporation, 557 Market Street, San Francisco.

ELECTRICAL CONTRACTORS

*ALTA ELECTRIC and Mechanical Company 467 O'Farrell Street, San Francisco

ELECTRICAL EQUIPMENT—SUPPLIES

*TRUMBULL ELECTRIC Mfg. Co., 260 Van Ness Avenue, San Francisco.

*GENERAL ELECTRIC Supply Corp., 1201 Bryant Street, San Francisco.

*NATIONAL ELECTRIC Products Co., 400 Potrero Avenue, San Francisco.

*WESTINGHOUSE ELECTRIC & Mfg. Co., 1 Montgomery Street, San Francisco.

ELEVATORS

*WESTINGHOUSE ELECTRIC Elevator Company, 1 Montgomery Street, San Francisco.

*OTIS ELEVATOR Company, Beach Street, San Francisco.

ENAMELING—PORCELAIN

FERRO ENAMELING Company, 1100 57th Street, Oakland.

FLOORING

ASPHALT TILE, Western Asbestos Company, 675 Townsend Street, San Francisco.

*L. S. CASE, Inc., 7th and Daggett Streets, San Francisco.

*JOHNS-MANVILLE Sales Corp., 116 New Montgomery Street, San Francisco.

MAPLE FLOORING MANUFACTURERS ASSOCIATION, McCormick Building, Chicago. Ask your lumber dealer.

LE ROY OLSON COMPANY, 3070 - 17th Street, San Francisco.

*LILLY & CROWLEY, 123 Kansas Street, San Francisco.

FIXTURES—BANK, OFFICE, STORE

MULLEN MANUFACTURING Co., 64 Rausch Street, San Francisco.

PACIFIC MANUFACTURING Company, 454 Montgomery Street, San Francisco, 1315 Seventh Street, Oakland, Los Angeles and Santa Clara.

ARCHITECTS' AND ENGINEERS' SPECIFICATION INDEX

Classified Directory of Building Material Manufacturers, Dealers and Contractors

*Denotes subscriber of ARCHITECTS' REPORTS, sponsored and endorsed by State Association of California Architects, and published daily by THE ARCHITECT AND ENGINEER.

FURNITURE

- *ALLIED ART GUILD, Menlo Park.
- *PENN. FURNITURE Shops, Inc., 130 Second Avenue, San Mateo.

GAS BURNERS

- VAUGHN-G. E. WITT Company, 4224-28 Hollis Street, Emeryville, Oakland.

GLASS

- W. P. FULLER & Co., 301 Mission Street, San Francisco. Branches and dealers throughout the West.
- LIBBEY-OWENS-FORD GLASS Co., Toledo, Ohio; 633 Rialto Building, San Francisco; 1212 Architect's Building, Los Angeles; 550 Skinner Building, Seattle.
- PITTSBURGH PLATE GLASS Company, Grant Building, Pittsburgh, Pa. W. P. Fuller & Co., Pacific Coast Distributors.
- *L. H. BUTCHER COMPANY, Fifteenth and Vermont Sts., San Francisco.
- *EAST BAY GLASS Company, 621 Sixth Street, Oakland.
- *COBBLEDICK-KIBBE GLASS Company, San Francisco and Oakland.

HEATING—ELECTRIC

- WESIX ELECTRIC Heater Company, 390 First Street, San Francisco; 631 San Julian Street, Los Angeles; 2008 Third Avenue, Seattle, Wash.

HEATING—GAS

- PACIFIC GAS & ELECTRIC Co., 245 Market Street, San Francisco.
- GENERAL Air Conditioning & Heating Company 4001 Piedmont Avenue, Oakland.
- HARER-PERRY Co., 5662 Keith Avenue, Oakland.
- *W. H. PICARD, Inc., 4166 Broadway, Oakland.
- *ALADDIN HEATING Corp., 5107 Broadway, Oakland.

HEATING—OIL

- S. T. JOHNSON Company, 940 Arlington, Oakland.

HEAT GENERATORS

- *WATROLO CORPORATION, LTD., 1170 Howard Street, San Francisco.

HEATING & VENTILATING EQUIPMENT

- *AMERICAN RADIATOR Company, 4th and Townsend Streets, San Francisco.

HEAT REGULATION

- JOHNSON SERVICE Company, Milwaukee, represented on the Pacific Coast by the following branch offices: 814 Rialto Bldg., San Francisco; 153 West Avenue, 34, Los Angeles; 1312 N.W. Raleigh Street, Portland, and 473 Coleman Bldg., Seattle.

HOLLOW BUILDING TILE (Burned Clay)

- N. CLARK & SONS, 116 Natoma Street, San Francisco.
- GLADDING McBEAN & Co., 9th and Harrison Streets, San Francisco; 2901 Los Feliz Boulevard, Los Angeles; 1500 First Avenue South, Seattle; 79 S.E. Taylor Street, Portland; 22nd and Market Street, Oakland; 1102 N. Monroe Street, Spokane; Vancouver, B.C.
- KRAFTILE Company, Niles, California, and 525 Market Street, San Francisco.

HOTEL AND RESTAURANT EQUIPMENT

- *DOHRMANN HOTEL SUPPLY Company, 973 Mission Street, San Francisco.

INSPECTION AND TESTS

- ABBOT A. HANKS, Inc., 624 Sacramento Street, San Francisco.
- ROBERT W. HUNT Co., 251 Kearny Street, San Francisco.

INSULATION

- CELOTEX Corp., 675 Townsend Street, San Francisco.
- *JOHNS-MANVILLE Sales Corp., 116 New Montgomery Street, San Francisco.
- WESTERN ASBESTOS Co., 675 Townsend Street, San Francisco.
- CABOT'S QUILT—Gunn, Carle & Co., 20 Potrero Avenue, San Francisco.
- VAPORSEAL, Mfg. by Celotex Corp., 919 N. Michigan Avenue, Chicago.
- FIRTEX of Northern California, 461 Market Street, San Francisco.
- *GEORGE D. KARSCH, Builders Exchange, Sacramento, California.

INSURANCE

- *FIREMAN'S FUND Insurance Company, 401 California Street, San Francisco.

INTERIOR DECORATORS

- *REED DRAPERY SERVICE, 440 Post Street, San Francisco.
- *M. H. WALES, 1933 Laguna Street, San Francisco.

KITCHEN EQUIPMENT

- *MANGRUM, HOLBROOK & ELKUS, 301 Golden Gate Avenue, San Francisco.

LACQUERS

- W. P. FULLER & Co., 301 Mission Street, San Francisco. Branches and dealers throughout the West.

LIGHTING FIXTURES

- *W. W. WARREN Company, 955 Mission Street, San Francisco.
- *INCANDESCENT SUPPLY Company, 726 Mission Street, San Francisco.
- *PHOENIX-DAY Company, 729 Mission Street, San Francisco.

LIMESTONE

- *INDIANA LIMESTONE Company, 130 Lunado Way, San Francisco.

LINOLEUM, CARPETS, Etc.

- *WEST COAST LINOLEUM & CARPET Co., 1163 Market Street.
- *VAN FLEET-FREAR Company, 557 Howard Street, San Francisco.
- TURNER RESILIENT FLOORS, Inc., 141 New Montgomery Street, San Francisco.
- *D. N. & E. WALTER & Company, 562 Mission Street, San Francisco.
- *CONGOLEUM-NAIRN, Inc., 180 New Montgomery Street, San Francisco.
- *K. M. BURCK, 505 B Street, San Mateo.

LOCKERS—METAL

- *TRASK & SQUIER, 39 Natoma Street, San Francisco.

LUMBER

- PACIFIC MFG. Co., 454 Montgomery Street, San Francisco; 1315 Seventh Street, Oakland; Los Angeles and Santa Clara.
- SMITH LUMBER Company, Nineteenth Avenue and Estuary, Oakland.
- MELROSE LUMBER & SUPPLY Co., Forty-sixth Avenue and E. Twelfth Street, Oakland.
- E. K. WOOD LUMBER Company, 4701 Santa Fe Avenue, Los Angeles; 1 Drumm Street, San Francisco; Frederick and King Streets, Oakland.
- *SANTA FE LUMBER Company, 16 California Street, San Francisco.
- FRIEND & TERRY LUMBER Co., Front & S Streets, Sacramento.
- *OAKLAND LUMBER Co., 6901 E. 14th Street, Oakland.

MACHINERY—PUMPS, Etc.

- SIMONDS MACHINERY Company, 816 Folsom Street, San Francisco.

MARBLE

- JOSEPH MUSTO SONS-KEENAN Co., 535 N. Point Street, San Francisco.

MILLWORK

- E. K. WOOD LUMBER Company, No. 1 Drumm Street, San Francisco, Oakland and Los Angeles.
- LANNON BROS. Mfg. Co., Fifth and Magnolia Streets, Oakland.
- MELROSE LUMBER & SUPPLY Company, Forty-sixth Avenue and E. Twelfth Street, Oakland.
- PACIFIC MFG. Co., 454 Montgomery Street, San Francisco; 1315 Seventh Street, Oakland; Los Angeles and Santa Clara.
- SMITH LUMBER Company, Nineteenth Avenue and Estuary, Oakland.
- *WESTERN DOOR and SASH Company, 5th and Cypress Streets, Oakland.
- *OAKHEAD PLANING MILL, 105 Washington Street, Oakland.
- *T. T. HOGAN Company, 2d and Alice Streets, Oakland; 630 Mission Street, San Francisco.
- *SAN MATEO PLANING MILL, San Mateo.

MONEL METAL

- "INCO" BRAND, distributed on the Pacific Coast by the Pacific Metals Company, 3100-19th Street, San Francisco, and 1400 So. Alameda Street, Los Angeles.
- *OAKHEAD METAL APPLIANCE CO., 4238 Broadway, Oakland.

NURSERY STOCK

- *C. J. BURR, 305 Lytton Avenue, Palo Alto.
- *CALIFORNIA NURSERIES, Niles.

OIL BURNERS

- *SAN MATEO FEED and FUEL Company, San Mateo, Cal.
- S. T. JOHNSON Co., 585 Potrero Avenue, San Francisco; 940 Arlington Street, Oakland; 1729 Front Street, Sacramento, and 1020 El Camino Real, San Carlos, Calif.
- VAUGHN-G. E. WITT Co., 4224-28 Hollis Street, Emeryville, Oakland.
- *HORABIN OIL & BURNER Company, 234 Hamilton Avenue, Palo Alto.
- PAN-AMERICAN SIMPLEX OIL BURNER, 820 Parker Street, Berkeley.

ONIX

- JOSEPH MUSTO SONS-KEENAN Co., 535 N. Point Street, San Francisco.

ORNAMENTAL IRON

- INDEPENDENT IRON WORKS, 821 Pine Street, Oakland.

PAINTING, DECORATING, Etc.

- THE TORMEY Co., 563 Fulton Street, San Francisco.
- *RAPHAEL Company, 270 Tehama Street, San Francisco.

PAINTS, OIL, LEAD

- W. P. FULLER & CO., 301 Mission Street, San Francisco. Branches and dealers throughout the West.
- FRANK W. DUNNE Co., 41st and Linden Streets, Oakland.
- NATIONAL LEAD Company, 2240-24th Street, San Francisco. Branch dealers in principal Coast cities.

- *SHERWIN-WILLIAMS Company, 1415 Sherwin Avenue, Oakland.

PARTITIONS—MOVABLE OFFICE

- PACIFIC MFG. Co., 454 Montgomery Street, San Francisco; 1315 Seventh Street, Oakland; factory at Santa Clara.

PLASTER

- "EMPIRE" and "RENO HARDWARE PLASTER," manufactured by Pacific Portland Cement Co., 111 Sutter Street, San Francisco; Portland, Los Angeles and San Diego.

ARCHITECTS' AND ENGINEERS' SPECIFICATION INDEX

Classified Directory of Building Material Manufacturers, Dealers and Contractors

*Denotes subscriber of ARCHITECTS' REPORTS, sponsored and endorsed by State Association of California Architects, and published daily by THE ARCHITECT AND ENGINEER.

PLASTERING CONTRACTOR

*JAMES F. SMITH, 271 Minna Street, San Francisco.

PLASTER—ACOUSTICAL

CALACOUSTIC, Sound Absorbing Plaster, manufactured by Pacific Portland Cement Co., 111 Sutter Street, San Francisco, Los Angeles and San Diego.

PLASTER MATERIALS

*U. S. GYPSUM Company, Architect's Building, Los Angeles.

PLATE GLASS

LIBBEY-OWENS-FORD GLASS Co., Toledo, Ohio; 633 Rialto Building, San Francisco; 1212 Architect's Building, Los Angeles; Mr. C. W. Holland, P.O. Box 3142, Seattle.

PLUMBING CONTRACTORS

CARL T. DOELL, 467-21st Street, Oakland.
*SCOTT Company, 243 Minna Street, San Francisco.

*W. H. PICARD, 4166 Broadway, Oakland.

PLUMBING FIXTURES AND SUPPLIES

CRANE Co., all principal Coast cities.
*STANDARD SANITARY Manufacturing Company, 278 Post Street, San Francisco.
*WALWORTH CALIFORNIA Company, 665 Sixth Street, San Francisco.
*W. R. AMES Co., 150 Hooper Street, San Francisco.

PRESSURE REGULATORS

VAUGHN-G. E. WITT Co., 4224-28 Hollis Street, Emeryville, Oakland.

PUMPS

SIMONDS MACHINERY Company, 816 Folsom Street, San Francisco.

REFRIGERATION

FRIGIDAIRE ELECTRIC REFRIGERATORS, Aladdin Heating Corp., 5107 Broadway, Oakland.

ROOFING CONTRACTORS

*MALLOTT & PETERSON, 2412 Harrison Street, San Francisco.

ROOFING INSULATION

*JOHNS-MANVILLE Sales Corp., 116 New Montgomery Street, San Francisco.

ROOF MATERIALS

*JOHNS-MANVILLE Sales Corp., 116 New Montgomery Street, San Francisco.
*PIONEER FLINTKOTE Company, Shell Building, San Francisco.
*PARAFFINE Company, Inc., 475 Brannan Street, San Francisco.
GLADDING McBEAN & Co., 9th and Harrison Streets, San Francisco; 2901 Los Feliz Boulevard, Los Angeles; 1500 First Avenue South, Seattle; 79 S.E. Taylor Street, Portland; 22nd and Market Street, Oakland; 1102 N. Monroe Street, Spokane-Vancouver, B.C.
*MARSHALL SHINGLE Company, 608-16th Street, Oakland.

N. CLARK & SONS, 112-116 Natoma Street San Francisco; works, West Alameda.

*CERTAIN-TEED PRODUCTS Co., 315 Montgomery Street, San Francisco.

SAFES

HERRING-HALL-MARVIN SAFE Co., 214 California Street, San Francisco.

SAND, ROCK AND GRAVEL

JOHN CASSARETTO, Sixth and Channel Streets, San Francisco.

BASALT ROCK Co., Napa.

*KAISER PAVING Company, Latham Square Building, Oakland.

MELROSE BUILDING MATERIAL Co., 4501 Tidewater Avenue, Oakland.

SCREENS

ROLL-AWAY WINDOW SCREEN Company, Eighth and Carlton Streets, Berkeley; 557 Market Street, San Francisco.

SEATING

*HEYWOOD-WAKEFIELD Co., 180 New Montgomery Street, San Francisco.

*GENERAL SEATING Company, 160 Second Street, San Francisco.

SHADE CLOTH

CALIFORNIA SHADE CLOTH Co., 210 Bayshore Boulevard, San Francisco.

SHINGLE STAINS

CABOT'S CREOSOTE STAINS, Gunn-Carle & Co., 20 Potrero Ave., San Francisco.

AUTO SPRINKLERS

GLOBE AUTOMATIC SPRINKLER Co., 665-6th Street, San Francisco.

STANDARD STEEL BUILDINGS

INDEPENDENT IRON WORKS, 821 Pine Street, Oakland.

STEEL FURNITURE

*GENERAL FIREPROOFING Company, 160 Second Street, San Francisco.

STEEL—REINFORCING

*SOULE STEEL Company, Army Street, San Francisco and Los Angeles.

GUNN-CARLE Company, Potrero Avenue San Francisco.

CECO STEEL PRODUCTS Co., 1280 Indiana Street, San Francisco.

*W. C. HAUCK & Co., 280 San Bruno Avenue, San Francisco.

*TRUSCON STEEL Company, 604 Mission Street, San Francisco.

STEEL—STAINLESS

REPUBLIC STEEL Corporation, Rialto Building, San Francisco; Edison Building, Los Angeles; White-Henry-Stuart Building, Seattle.

STEEL—STRUCTURAL

INDEPENDENT IRON WORKS, 821 Pine Street, Oakland.

JUDSON PACIFIC Company, C. F. Weber Building, Mission and Second Streets; San Francisco shops, San Francisco and Oakland.

HERRICK IRON WORKS, 18th and Campbell Streets, Oakland.

*MOORE DRYDOCK Company, Foot of Adeline Street, Oakland.

*WESTERN IRON WORKS, 141 Beale Street, San Francisco.

COLUMBIA STEEL Company, Russ Building, San Francisco.

STORE FIXTURES

MULLEN MFG. Co., 60 Rausch Street, San Francisco.

STORE FRONTS

KAWNEER MFG. Co., Eighth Street and Dwight Way, Berkeley.

TEMPERATURE REGULATION

JOHNSON SERVICE Company, Milwaukee, represented on the Pacific Coast by the following branch offices: 814 Rialto Building, San Francisco; 153 West Avenue, 34, Los Angeles; 1312 N.W. Raleigh Street, Portland, and 473 Coleman Building, Seattle.

TELEPHONES—INTERCOMMUNICATING

*PACIFIC TELEPHONE and TELEGRAPH Company, 140 New Montgomery Street, San Francisco.

TERMITE CONTROL—WOOD PRESERVATIVE

E. K. WOOD LUMBER Company, No. 1 Drumm Street, San Francisco; 4701 Santa Fe Avenue, Los Angeles; Frederick and King Streets, Oakland.

TILE—DECORATIVE, Etc.

*CAMBRIDGE TILE MFG. Co., 1155 Harrison Street, San Francisco.

POMONA TILE MFG. Co., plant, Pomona, Cal.; Sales Rooms, 135 Tenth Street, San Francisco; 217 S. La Brea Avenue, Los Angeles; 6106 Roosevelt Way, Seattle.

GLADDING McBEAN & Co., 9th and Harrison Streets, San Francisco; 2901 Los Feliz Boulevard, Los Angeles.

KRAFFILE Company, Niles California, and 525 Market St., San Francisco.

*CALIFORNIA ART TILE Corp., Richmond, Cal.

TILE CONTRACTORS

*CAMBRIDGE WHEATLEY Company, 1155 Harrison Street, San Francisco.

TREE SURGERY

DAVEY TREE SURGERY Co., Ltd., Russ Building, San Francisco; Story Building, Los Angeles.

TRUSSES

*SUMMERBELL TRUSS Company, 405 Builders Exchange Building, Oakland.

*ARCH-RIB TRUSS Company, 608 Sixteenth Street, Oakland.

VALVES

*"KRAMER" Flush Valves, MacDonald Hardware Manufacturing Co., 963 Harrison Street, San Francisco.

SLOAN VALVE Company, Chicago, Ill

SHAND AND JURS Co., Eighth and Carlton Streets, Berkeley.

VARNISHES

NATIONAL LEAD Company, 2240-24th Street, San Francisco. Branches and dealers in all principal Coast cities.

W. P. FULLER Company, San Francisco and principal Coast cities.

FRANK W. DUNNE Co., 41st and Linden Streets, Oakland.

VENTILATING EQUIPMENT

*THE B. F. STURTEVANT Company, 759 Monadnock Building, San Francisco.

WALL BOARD

*WESTERN BUILDERS SUPPLY Company, 401 Fourth Street, San Francisco.

WATER HEATERS—GAS AND ELECTRIC

*WATROLA Corporation, Ltd., 1170 Howard Street, San Francisco.

*PITTSBURGH WATER HEATER Co., 898 Van Ness Avenue, San Francisco.

*RUUD HEATER Company, 437 Sutter Street, San Francisco.

WESIX ELECTRIC HEATER Company, 380 First Street, San Francisco.

WINDOW SASH AND FIXTURES

"DALMO," SIMPLEX and "HAUSER" Casement Windows, MacDonald Hardware Mfg. Co., 963 Harrison Street, San Francisco.

*DETROIT STEEL PRODUCTS Co., 111 Sutter Street, San Francisco.

KAWNEER MFG. Company, Dwight Way and Eighth Street, Berkeley.

WINDOW SHADES

AEROSHADE Company, represented by W. R. Knight, 557 Market Street, San Francisco.

CALIFORNIA SHADE CLOTH Co., 210 Bayshore Boulevard, San Francisco.

INDEX TO ADVERTISEMENTS

*Indicates Alternate Months

A		K	
ALADDIN Heating Corp.	10	KAWNEER Company	*
AMERICAN Brass Company	*	KRAFTILE Company	72
ANACONDA Copper Company	*		
ANDERSON & Ringrose	74	L	
ARCHITECTS Building	70	LANNOM Bros. Manufacturing Company	74
		LIBBEY, Owens, Ford Glass Company	9
B		LINDGREN & Swinerton, Inc.	69
BASALT Rock Company	70		
BUILDING Material Exhibit	70	M	
C		MacDONALD Hardware Manufacturing Company	4
CASSARETTO, John	75	MAPLE Flooring Manufacturers Association	5
CELOTEX Corporation	Third Cover	MERCURY Press	75
CLARK, N., and Sons	11	MULLEN Manufacturing Company	71
CLINTON Construction Company	74	MUSTO Sons Keenan Company, Joseph	75
COLUMBIA Steel Company	*		
CRANE Company	3	N	
CROCKER, H. S.	71	NATIONAL Lead Company	71
D		P	
DAVEY Tree Surgery Company	70	PACIFIC Coast Gas Association	7
DELCO-FRIGIDAIRE	10	PACIFIC Coast Electrical Bureau	67
DINWIDDIE Construction Company	75	PACIFIC Foundry Company, Ltd.	69
DOELL, Carl T., Company	75	PACIFIC Manufacturing Company	72
DUNNE Company, Frank W.	75	PACIFIC Portland Cement Company	*
		PAN-AMERICAN Engineering Co.	73
F		PITCHER Company, E. C.	74
FERRO-PORCELAIN Building Co.	74	PITTSBURGH Plate Glass Company	*
FULLER Company, W. P.	*	PORTLAND Cement Association	Back Cover
FORDERER Cornice Works	73		
G		R	
GLADDING, McBean & Company	*	REPUBLIC Steel Corporation	75
GOLDEN Gate Atlas Materials Company	72	ROLL-A-WAY Window Screen Company	74
GUNN, Carle & Company	2		
H		S	
HANKS, Inc., Abbot A.	73	SANTA Maria Inn	71
HARER-Perry Company	70	SIMONDS Machinery Company	75
HAWS Drinking Faucet Company	72	SISALKRAFT Company	72
HERRICK Iron Works	73	SLOAN Valve Co.	Second Cover
HOLLEY Manufacturing Co.	70	SMITH Lumber Company	75
HOTEL CLAREMONT	71	STANLEY Works	*
HOTEL CLARK	75		
HUNT, Robert W. Company	71	T	
HUNTER and Hudson	75	TORMEY Company, The	75
I		U	
INCANDESCENT Supply Company	70	UNITED States Steel Products Company	*
INDEPENDENT Iron Works	74		
J		V	
JENSEN & Son, G. P. W.	71	VAUGHAN-G. E. Witt Company	73
JOHNSON, S. T., Company	68		
JOHNSON Service Company	*	W	
JUDSON Pacific Company	70	WESIX Electric Heater Company	73
		WOOD, E. K., Company	68
		WESTERN Asbestos Company	70

THE
ARCHITECT
AND

ENGINEER

SAN FRANCISCO
PUBLIC LIBRARY
PERIODICAL DEPT.

AMERICAN TRUST COMPANY

JUNE 1938

TAN PLASTIC PROVIDES *Beauty plus Protection* for This GE Model Home



*General Electric Model Home, Berkeley, California.
John Ekin Dinwiddie, Architect J. M. Walker, Builder*

"We knew when construction of this model home was started that it would be the show place of the San Francisco Bay district.

"Literally thousands upon thousands of people were destined to inspect it before it was finally placed on the market and sold, and it naturally followed that neither expense nor effort were spared in the selection of materials for its construction.

"Logically then, Pacific Portland Cement Company's Tan Plastic Cement was selected for all stucco and concrete work. The results speak for themselves."

(Signed) J. M. WALKER, Builder

LEADING ARCHITECTS SPECIFY IT
COMPETENT BUILDERS USE IT
RELIABLE DEALERS HANDLE IT

*S*OUND home construction includes *permanent* protection against moisture. TAN PLASTIC Waterproof Cement provides the strength of *True* Portland Cement but seals out dampness forever.

Try TAN PLASTIC on your next job — see how its *pourability* makes impervious, pocket-proof concrete — how easily it handles — how smoothly it works. Used right, it never disappoints.



PACIFIC PORTLAND CEMENT COMPANY

SAN FRANCISCO · LOS ANGELES · COASTWIDE SERVICE · PORTLAND · SEASIDE

THE ARCHITECT & ENGINEER

June .. 1938 .. Contents

COVER

AMERICAN TRUST BUILDING, SACRAMENTO, CALIFORNIA
Harry J. Devine, Architect

EDITOR
Fred'k W. Jones

CONSULTING BOARD
OF EDITORS

FRONTISPIECE

DETAIL, ERNEST INGOLD AUTOMOBILE DISPLAY AND SERVICE BUILDING, SAN FRANCISCO
John Ekin Dinwiddie, Architect

Architectural—

Arthur Brown, Jr.
Frederick H. Meyer
Timothy L. Pflueger
Will G. Corlett
Harry Michelsen
Lewis P. Hobart
David C. Allison
Gordon B. Kaufmann
Harris C. Allen

TEXT

MODERN TREND REFLECTED IN NEW AUTO SALES BUILDING	13
John Ekin Dinwiddie, Architect	
UNIFICATION OF THE ARCHITECTURAL PROFESSION	21
Harry M. Michelsen	
NEW NOTE IN INDUSTRIAL BUILDING DESIGN	25
I AM A STOCK PLAN BOOK	29
L. S. Sanderson, Architect	
SPRECKELS SUGAR PLANT AT WOODLAND, CALIFORNIA	31
Harry M. Thomsen, Jr., Architect	
THE ARCHITECT AND HIS SHORT COMINGS	35
Frederick Hamilton	
NEW FEDERAL BUILDING AT REDDING, CALIFORNIA	39
Homer N. Hadley	
TRENDS IN HOME DECORATION	41
Mary Davis Gillies	
BUILDING BAY BRIDGE RAILROAD TERMINAL	43
WORLD'S FAIR BUILDERS—ERNEST E. WEIHE	47

Engineering—

H. J. Brunner
L. H. Nishkian
William Adrian
Wm. H. Popert
Homer N. Hadley
Geo. E. Atkins

Assistant Editor—

Edgar N. Kierulff

Advertising Manager—

J. Leslie Meek

Architects' Reports—

Vernon S. Yallop

PLATES AND ILLUSTRATIONS

Ernest Ingold Automobile Display and Service Building	13-19
John Ekin Dinwiddie, Architect	
Building for Owens-Illinois Pacific Coast Company, Oakland	25
Spreckels Sugar Refinery, Near Woodland, California	30-33
Geo. W. Kelham and Harry A. Thomsen, Architects	
Ranch House, Lafayette, California	34
John Ekin Dinwiddie, Architect	
New Federal Building, Redding, California	39-40
Albert F. Roller, Architect	
San Francisco-Oakland Bay Bridge Terminal	43-46

THE ARCHITECT AND ENGINEER, INC., 68 Post Street, San Francisco, EXbrook 7182. President, K. P. Kierulff; vice-president, Frederick W. Jones; secretary, L. B. Penhorough. Los Angeles office, 832 W. Fifth Street. Published on the 12th on each month. Entered as second class matter, November 2, 1905, at the Postoffice at San Francisco, California, under the Act of March 3, 1897. Subscriptions, United States and Pan America, \$3.00 a year; Foreign countries, \$5.00 a year; single copy, \$.50.

Notes and Comments

"Functional architecture" is a phrase that thrums from many a harp today, with the persistence of something new and strange. The house is described as a machine for living—as a part of its surroundings, to be blended with the easy comfort of an old shoe into every requirement of home life.

All this is true, and was true, before architecture existed, as we know it today, in the United States. An example is the housing history of the buffalo-hunting Indian of the Great Plains. First they lived in earth lodges, circular and as large as 100 feet in diameter. These were topped by conical roofs which began at ground level and built of poles, thatch and sod. Mandans, Pawnees, Kiowas and many others used them.

As the horse became more common, these tribes became nomadic to follow the buffalo. They abandoned the earth lodge in favor of the teepee—the most efficient type of portable shelter imaginable, until trailer days. The teepee was made of tanned buffalo hides until the herds were destroyed, when the red man easily adapted himself to canvas. Canvas is lighter and better, and it is doubtful if teepee-dwellers of today would go back to the buffalo hide if they could.

Functionalism, with the regional variation of primitive housing, will be an important part of the \$500,000 Indian presentation at the Golden Gate International Exposition in 1939. "The number of different Indian houses is unbelievable," says Rene d'Harnoncourt, manager of the Federal Indian Arts and Crafts Board, who is in charge of the presentation.

H. H. Richardson's three indispensable requirements for good architecture: (a) Get the job, (b) Get the job, (c) Get the job.

A Chicago architect, in a communication to the Monthly Bulletin of the Illinois Society of Architects, offers the following suggestions as possible remedies for curing the existing ills of the building industry in general and the architectural profession in particular:

"We can, for the near future, continue to 'trim our sails to meet the business weather' of the next few years, meanwhile planning for the future on a sound stable basis. We can promote saner ways of financing construction. We can revamp our antiquated building codes and laws. We can study the rebuilding of our vast slum areas in terms of socialized planning. We can promote the welfare of our urban centers by introducing new methods of city planning, larger areas of fresh air and sunlight, and in general a more practical and beautiful relation of units. And, last but not least, we can campaign to arouse and create public interest

in architecture and in the social and economic value of the architect.

"We can take a keener interest in our architectural education and requirements, eliminating from the field those not fully qualified to practice or those who are not temperamentally fit to assume their professional duty to the public. In place of six hundred underpaid positions, it would be better to graduate half as many qualified to make their proper contribution to society."

The first of a series of "Consult Your Architect" motion pictures for commercial and educational showing will be released by Mason Wadsworth, New York and Hollywood business film producers, shortly. Terry Kimball, of the Mason Wadsworth staff, has been appointed managing editor, and will be assisted by a reviewing committee of American architects. This series is designed to show the importance of the work of American architects in the building of America—and the building of the America of tomorrow.

"He didn't carve a career for himself as an architect, he chiselled it."

Eliminate the appalling loss of life on highways. Stop the loss of life from accidental causes in the home and in industry. That's

the program for the Western Safety Conference to be held in Los Angeles September 12-16. Sectional meetings will be held in connection with the conference covering the building industry, aviation, motion picture, industrial safety in all such institutions, traffic, home and public safety.

The facts enumerated in the following editorial in the San Francisco Chronicle if true seem almost incredible in these times of unemployment and financial worry. Just what are we heading for anyway?

"It is astounding to see employing painters and unions agreeing to eliminate spray guns in painting office buildings and houses. This is simply an attack on the consumer—that is everyone who owns or rents offices or homes. It is to make all of these pay an unnecessary cost of hand painting where the value is no more than that of the cheaper spray gun painting. In other words, it is a holdup.

"As such it is a stupid holdup. It is a holdup applied to the building industry by which both the employing painters and the working painters make their living. It is a scheme to give an unnecessary boost to the high costs that now discourage building. It is a scheme, therefore, to discourage building and make less business for employing painters and less work for working painters. It is astonishing that both of these should be so shortsighted.

"If this holdup is to set a precedent we may expect next to see master painters and working painters conspiring to soak the consumer again by banning the use of factory mixed paints and requiring all paints and varnishes to be mixed on the job. It would be just as logical for other building trades and their employers to conspire to ban the use of steam shovels, cement mixers, electric hoists, rivet guns and all other mechanica helps so as to make building of all kinds cost more. We might get back to agreement between contractors and unions to use one-horse carts for delivery of their materials so as to make work for stablemen in the city and haymakers on the farms or better still, the materials might be carried on the backs of the men who are to use them.

"This would certainly jolt prospective builders, and prospective renovators of buildings already built. It would be a fine way wouldn't it, to cooperate in getting the building industry going again? What a help to people who would like to build if it were not for excessive costs!

"Nor do we see any choice between the master painters who have agreed and the unions with which they have agreed. They are equally culpable. Both sides are in a conspiracy to gyp the consumer—and their own industry."

That Desired SOFT WEATHERED SILVERY GREY

ON
Shingles, Shakes

AND
Other Exterior
Woodwork

IS SECURED

BY USING

CABOT'S BLEACHING OIL

●
GUNN, CARLE & CO.

DISTRIBUTORS

20 Potrero Avenue

San Francisco

UNDERhill 5480

LIBERAL USE OF RUSTLESS METAL Makes Any Store Front Design More Effective

SEE ZOURI FOR:

- ✓ THE COMPLETE STORE FRONT INCLUDING—
- ✓ SASH AND BARS
- ✓ AWNING BARS
- ✓ ENTRANCE DOORS
- ✓ PILASTERS
- ✓ MOULDINGS
- ✓ METAL SIGN LETTERS
- ✓ PANELING
- ✓ ORNAMENTAL WORK



Glass Protection

To be safe, plate glass must be handled and HELD with care! That's why the new ZOURI Extruded Sash and Bars as well as the famous Rolled Safety Key - set construction are designed to provide FULL CUSHION GRIP on glass. This important feature assures maximum protection against the danger and expense of glass breakage — protection vital to the satisfaction of owner and merchant.

Important to architects and builders is the modern demand for more attractive store fronts. That's why store front designers are turning to the liberal use of ZOURI Rustless Metal — for its life and lustre, for rich lasting beauty, and for interesting lines and contrasts.

Zouri offers a complete line of store front construction in either rolled or extruded metal. In most cases striking effects may be obtained by the use of standard sections,

which are carried in stock. In others, ZOURI fabricates special architectural metal work in aluminum, bronze or stainless steel—to face the entire front with modern metal, to produce doors or metal letters in harmony with the store front design, or to satisfy any modern demand. A 14-page catalog is at your disposal in SWEET'S. See your ZOURI distributor or write direct to ZOURI STORE FRONTS, BERKELEY, CAL., for f. s. details.

ZOURI STORE FRONTS

*Mark Daniels and his "Running Fire"
have caught The Architect and Engineer*

It is the kid in us that prompts us to run to a fire. It is the craving for refreshing wit and penetrating thought that prompts us to pursue "Running Fire." *The Architect and Engineer* has been chasing "Running Fire" for several years and has at last caught up with it. Whether it has burned out or lost any of its heat you will learn by reading the July issue, for in that number Mr. Mark Daniels will continue his pungent column "Running Fire," impatiently awaited by all who have read it, and quoted in many parts of the world.

Mr. Daniels is distinguished in most branches of the arts. As a member of the American Institute of Architects he has designed buildings in many parts of the United States and in foreign lands. As a landscape architect he has planned and developed a large number of famous residence parks and private estates and is at present directing the landscape treatment of the Golden Gate International Exposition that is being developed for the State of California.

As a writer Mr. Daniels is the author of such works as "Green Symbols" and several plays for the famous Bohemian and Family Clubs. Now, as Associate Editor of *The Architect and Engineer*, he will continue his "Running Fire" and various essays on architecture, gardening, botany, music and travel.

Don't miss the July issue.

The Editor

GROUND COVERS

By BERNIECE ASHDOWN

GROUND covering plants, although much more important than many better known groups of plants, are often overlooked by amateur gardeners. There are countless places in the average garden where good ground covers greatly enhance beauty and value. In place of lawns, on hillsides, under trees, shrubs or bulbs, on dry sandy banks or for odd corners in the garden, they are indispensable. They include a wide range of trailing, semi-trailing and dwarf tufted plants and shrubs, most of which are hardy as well as inexpensive.

There are many plants which are charming when planted among bulbs. They not only make a more attractive setting for the bulbs in bloom, but prevent the dry, bare appearance which usually follows short blooming seasons. Suitable plants for planting under small bulbs include:

Veronica repens, with small leaves and pale lavender flowers.

Sedum album, with attractive white flowers.

Mentha Requienii, for a moist shady place.

Gypsophila repens, which produces clouds of white flowers in summer.

Linaria cypalaria (Kenilworth ivy), a neat perennial plant with lavender and purple flowers.

For planting among larger bulbs: *Aubrietias* which grow 4 inches high and produce bright colored flowers in spring and early summer; *Arabis alpina*, a drought resisting plant with white flowers in spring; *Arenaria montana*, a creeping plant having attractive white flowers in early summer; *Veronica pectinata* which has lovely blue flowers in May and June; *Veronica repens* with showy light blue flowers in May; *Veronica nana* which forms a dense carpet of dark foliage one inch and has blue flowers in the spring; *Phlox amoena* with bright pink flowers; and *Phlox subulata* which bears myriads of white, blue, lilac and rose colored flowers above dark, moss-like foliage.

Planting has been used extensively to check erosion on steep banks. If the soil is rich and deep, *Cotoneasters* and *Junipers* are very desirable, as both have long roots which give sub-surface support as well as surface protection. The prostrate *Junipers* include: *Juniperus canadensis*, *J. chinensis procumbens*, *J. horizontalis*, *J. chinensis Sargentii*, *J. Sabina tamariscifolia*, *Cotoneaster adpressa*, *C. dammeri* and *C. horizontalis*. All grow flat to the ground and have attractive red berries.

For warm sandy hillsides and in places where water is scarce, *Mesembryanthemum australe* or *M. aequilalerale* are unequaled. *M. australe*, which has white flowers, is better for this purpose as it forms a dense thick, impenetrable carpet and is very hardy. There are, however, many other suitable varieties which have similar habits of growth and bear attractive bright colored flowers. The spotted rock rose (*Cistus cyprius*) is also a very

effective cover for dry slopes. The flowers are white, spotted with dark reddish brown.

There are many plants desirable for use as fill-ins to relieve seasonal bareness or to make odd corners more attractive. These include a wide range of low tufted and trailing plants adapted to extreme climatic and soil conditions.

In places where a blaze of color is desirable, *Lantanas* may be used. They grow rapidly and are extremely free flowering. The blossoms are lavender, yellow and red orange.

Tunica saxifraga is a neat, tufted plant which grows only a few inches high. It thrives in any soil and blooms all season with attractive pink blossoms.

Nepeta mussini grows about a foot high, has small aromatic, lavender-like foliage and pale mauve colored blossoms.

Silene maritima is well suited to hot, dry places and blooms in late summer with pinkish white flowers.

The horned violet (*Viola cornuta*) and the common garden violet (*Viola odorata*) make splendid ground covers. They grow well in any good garden soil in sun or semi-shade.

Planting beneath shade trees presents many problems. If the trees have many surface roots, they sap not only the food from the top soil but the water as well, making it very difficult for small plants to survive. Much can be done, however, by fertilizing frequently and watering during dry seasons. But even with extra care it is often impossible to raise grass or shrubs.

For planting beneath surface-rooted trees such as Norway Maple or Eucalyptus, nothing can surpass periwinkle (*Vinca*). They are evergreen, trailing plants which have blue, white or pink, funnel shaped blossoms. There are two varieties equally well suited to this purpose; the large leaved, better known *Vinca major* and the new *Vinca minor*, which has smaller leaves of the same color and texture.

Japanese spurge (*Pachysandra terminalis*) is also adaptable to this purpose. It grows six to eight inches tall, has glossy, light colored, evergreen foliage and small spikes of flowers in May or June. It grows equally well in sun or shade and has no special soil requirements, yet it pays large dividends for a little extra care.

Bugle (*Ajuga*), a creeping plant which grows six to eight inches tall, is another excellent shade plant. It blooms in May and June with attractive, lipped flowers. *Ajuga Brochbankii* has bronzy, metallic foliage and deep blue flowers. *A. reptans rubra* has the same type of foliage and paler blue flowers. *A. genevensis* has dark green foliage.

Hypericum calycinum is extensively used as a ground cover under trees in Golden Gate Park. It has attractive dark leaves and bright yellow blossoms which resemble stars.

For damp shady places, English ivy is very satisfactory. The miniature-leaved variety *Hedera Helix gracilis* is daintier than the generally grown type and is just as hardy.



Exposition Internationale Paris 1937
Pavillon Suisse. Jardin alpestre/Steingarten

SOCIETY SPONSORS GLASS HOUSE FOR FAIR

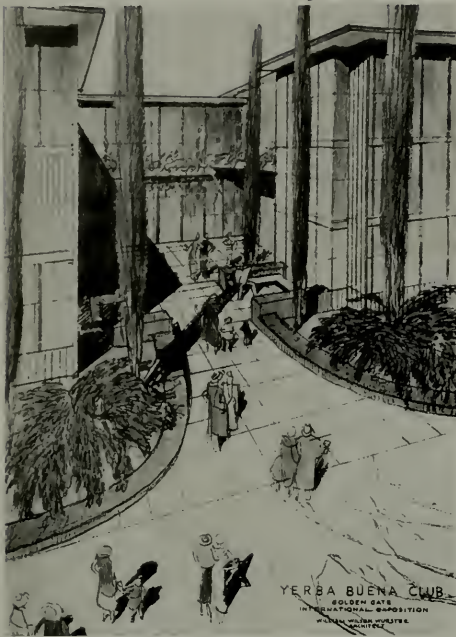

Sketch of building for Yerba Buena Women's Club, G. G. International Exposition. The architect, William W. Wurster, has deliberately subordinated architecture in an aim to enclose space, rather than build a structure.

SMART California women, with their flair for the unusual, have once again maneuvered the spotlight in their direction. They're building themselves a club house of glass at the 1939 Golden Gate International Exposition. The Yerba Buena Club, the official hospitality center of the Exposition, will be a building that's unique not only on Treasure Island, man-made site of the Fair, but in the whole of California.

William Wurster, architect, known for his country home and town house designs, has deliberately subordinated architecture in plans for the club, in his aim to enclose space rather than build a structure. Since Yerba Buena Club is one of Treasure Island's temporary buildings, no effort will be made to create an architectural landmark. The club is designed as a "frame for living," and its modern garden architecture technique is intended to enhance the beauty of the gardens which will surround it. The club house will be the only "out-turning" building on Treasure Island, in distinct contrast to the huge exhibit palaces with their intended impression of heaviness and stability.

The club house will occupy 33,390 square feet, at the south end of the Exposition grounds, between the Ad-

ministration Building and an airplane hangar, and will overlook a spacious lagoon. While some wood will be used in construction, glass will be the principal material. severely simple in line, with the exception of the balconies and terraces upon which every room on both floors will open. A ramp will lead from the first to the second story.

The first floor will house a large dining room, a smaller coffee shop, spacious central hall, lounge with cocktail bar, rest rooms, writing room, and a gay children's room opening on a special children's garden. The second floor features another large dining room, a private dining hall, auditorium, and Founders' room. The entire club house will be steam heated and air conditioned, but a number of working fireplaces have been included in the plans to satisfy the idea of coziness demanded by women.

The simple architectural design of the club house will be complemented by a profusion of color. The Furnishings, decorative accessories, and interior designs will incorporate all the exquisite colorings characteristic of California. Lemon-yellow curtains, vermilion chairs, peach table cloths, brilliant parasols, gay porch furniture are to be the dominating motifs.

ENGINEERED HARDWARE

FOR NEW SCHOOL CONSTRUCTION

DALMO SIMPLEX WINDOW FIXTURES

"THE NATION'S SCHOOLHOUSE WINDOW"

HAVE BEEN USED IN OVER 200 SCHOOLS IN CALIFORNIA IN THE PAST TWO YEARS

KRAMER FLUSH VALVES

SHEER SIMPLICITY OF CONSTRUCTION MAKES FOR POSITIVE PERFORMANCE AND LOW MAINTENANCE

MacDONALD 
HARDWARE MANUFACTURING CO.

YUkon 0123

963 Harrison St.

San Francisco



*High School
Montgomery, Minnesota*



*G. Washington Feaser Grade School
Middletown, Pennsylvania*



*Senior High School
Rock Island, Illinois*



*Oceanside High School
Oceanside, New York*

W

JOHNSON
TEMPERATURE
AND HUMIDITY
CONTROL
FOR
SCHOOLS

E



*Auditorium
Standard School District
Oildale, California*



*High School
Cumberland, Maryland*



*Cesar Cone School
Greensboro, North Carolina*

S

In all climates, Johnson has had extensive experience in temperature and humidity requirements for educational buildings. A single, nation-wide organization, engaged in just one line of business: Automatic Temperature Control applied to every type of heating, ventilating, and air conditioning system.

JOHNSON SERVICE COMPANY

MILWAUKEE, WISCONSIN AND DIRECT BRANCHES IN PRINCIPAL CITIES

PULSE OF THE READER

WANTS NEW MEXICO NUMBER

Dear Editor:

I have taken advantage of the slump to visit this much-talked-of Southern California city and its environment.

Having spent a month in New Mexico, I can not resist asking why you don't get out a New Mexico number? There is a state with some architecture worth talking about.

New work of special interest is a W.P.A. job on the University campus at Albuquerque and the U. S. Forestry Building at Taos. In the language of William Lescaze, used in describing his C.B.S. job here for the press, they are "functional" and show the process of applying thought to building design . . . which the Indians must have done also, for it is pleasant, though difficult, to pick out a new building from an old one. As they are all adobe the words "organic," "logic" and "low cost housing" seem peculiarly appropriate . . . and outside of the Goodhue Exposition palaces at San Diego, the only man-made objects I observed artists painting on the entire trip.

While I have seen a few delightful new buildings around L.A. in reward for intense rubber-necking, I have strained my vision in trying to pick them out of the maze of glaring red signs everywhere encountered . . . no few of which cover every square foot of facade and suggest an illustrated essay entitled, "Sign Writers vs. Architects in Los Angeles."

Yours very truly,

L. S. SANDERSON, Architect.
Los Angeles, May 1, '38.

REMEDY FOR DEPRESSION

Dear Editor:

It is the belief of this corporation that a simple formula will help restore employment, purchasing power and prosperity to this nation.

The formula, which we feel sure is the key to better business, consists in building the American salesman's morale to a point where he believes, as we do, that he is a figure of prime importance in our economic scheme.

We are convinced . . . and we want to instill this conviction in the minds of those who contact the ultimate buyer . . . that the salesman through untiring work not only creates the desire to own the products made by other men, but provides the employment that furnishes a still greater market for the countless products of farm and factory. Thus, the salesman is one of the most important men in America today, possessed of the

power, if he acts in concert with his fellow-salesmen, to help this country back to prosperity.

The task, as we see it, is turning the business wheel past dead center—and we believe this is the salesman's job. We believe further that there are plenty of people left with the ability and the willingness to buy if the salesman presents his product so as to awaken a desire for ownership stronger than the fears that have kept people from satisfying their normal needs, hence we have inaugurated a movement called the "National Salesmen's Crusade."

Back of the salesman's crusade is the belief that if the salesman of America can be made to realize how vitally important their efforts are to the general economic welfare of the nation, a real step will have been made in the direction of lasting recovery.

Cordially,

NASH-KELVINATOR CORPORATION.

T. H. MASON, President.

THE BEST YET

Dear Editor:

Yesterday we received through the mail our copy of *The Architect and Engineer* for May.

Both my brother and I feel that the material in this issue was set up in a thoroughly beautiful way. The arrangement of the photographs on the pages with pertinent paragraphs underneath in each case made a very fine effect and Morrow's little foreword and comments were very good and much to the point.

We believe the format and general makeup constitute one of the most attractive issues (architecture excepted) that you have put out.

We should like to have 50 copies of this number at least, and if you have others on hand will you please let us know what another fifty could be had for.

Assuring you of our appreciation of the fine issue you have given our work, and with kindest personal regards, we are,

Very truly yours,

ALLISON & ALLISON,

By DAVID C. ALLISON,

Los Angeles, May 20, '38.

STOCK PLANS

Dear Editor:

"Stock Plans" always make an interesting subject for discussion. Let's quote from Wm. H. Reid, Jr., architect, Billings, Montana, in his recent report to the Committee on Housing, A.I.A.:

"In answer to your question: 'How do Billings architects feel about the use of stock plans or plan books for homes in the \$5,000 bracket?' I will reiterate my story to Mr. Pierce as briefed to you in his report.

"For my part, I have found in the past three years, after working on some 200 home plans, varying in price from \$4,000 to \$10,000, the majority of which were in the interpreted \$5,000 bracket, that stock plans have been of able assistance generally, in this office. An inherited feeling, acquired perhaps while working on residences in the higher brackets, was entirely overcome when we put the so-called nuisance to work for us.

"An office working with homes in the \$5,000 bracket must make economy a first law. Economy must be maintained along all avenues of contribution, to the final completion of the project. Success lies in quality, but in the \$5,000 bracket it is quality strained through economy. Labor and materials from every trade and craft must feel its responsibility and the architect is not immune.

"Upon a thorough investigation of any community, stock plans and plan services will be found firmly established. They are backed by substantial, existing examples and living sales propaganda furnished by lumber and building material dealers. With this as a foregone conclusion, the architect must catch the disease and live with it, or harness it with a toxin.

"It is a proven fact that the average prospective home owner will finger through many plan services and books, and come up with a knitted brow. A man's home is as individual as his thumb print and his family has a great deal to do with the development of that print. 'The plan is reverse; the bedroom could be increased two feet without serious cost effect; it only has a half basement; I'd like to increase the dormer on the rear to give Jimmie enough room to get into his PJ's; Dad likes a big bathroom; can't we add a coat closet at the entrance; Mother must have more closet space or additional cabinet space in the kitchen; where's the broom closet and the laundry chute? Junior must have a work shop and bicycle space in the garage; boy, wouldn't that be a honey drawn up in one of those new-day, hispano-anglais effects; change the stone front to one of those stucco and wide siding, half-timber and brick combinations—like the banker's house on Eucalyptus Street.' On and on into the night, until you find the sponsor of the plan service hiring local students

(Please turn to Page 74)

Specify "PENNVERNON"...not just "window glass" ⁵⁷



Photograph by Johnston & Johnston

Pennvernon
double strength
WINDOW GLASS



ACCURATE TO OUNCES IN MANY TONS! The pure, specially selected Pennvernon ingredients are carefully weighed by this Pennvernon Craftsman as his contribution to the creation of that superior quality for which Pennvernon Window Glass has become justly famous.

Our new booklet, called "The Making of a Leader", describes in dramatic pictures the manufacture of Pennvernon Window Glass. To get your copy of this interesting book, sign and mail this coupon to

PITTSBURGH
PLATE GLASS COMPANY
2375 Grant Building, Pittsburgh, Pa.

Name _____
Address _____
City _____ State _____

W. P. FULLER & CO., PACIFIC COAST DISTRIBUTORS



ASK YOUR CLIENT:

"Why get rustable pipe when Anaconda Copper Tubes cost hardly any more?"

Copper Tubes...*the outstanding "buy"*

for low-cost, durable piping

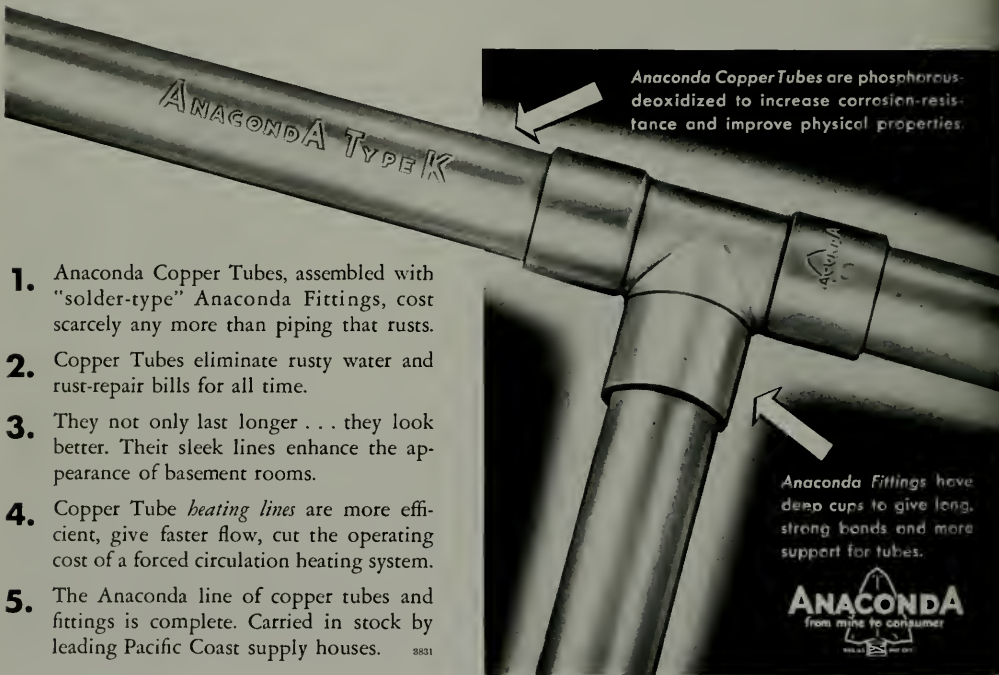

Anaconda Copper Tubes are phosphorus-deoxidized to increase corrosion-resistance and improve physical properties.

1. Anaconda Copper Tubes, assembled with "solder-type" Anaconda Fittings, cost scarcely any more than piping that rusts.
2. Copper Tubes eliminate rusty water and rust-repair bills for all time.
3. They not only last longer . . . they look better. Their sleek lines enhance the appearance of basement rooms.
4. Copper Tube *beating lines* are more efficient, give faster flow, cut the operating cost of a forced circulation heating system.
5. The Anaconda line of copper tubes and fittings is complete. Carried in stock by leading Pacific Coast supply houses. 8831

Anaconda Fittings have deep cups to give long, strong bonds and more support for tubes.



Anaconda DEOXIDIZED Copper Tubes

THE AMERICAN BRASS COMPANY • General Offices: WATERBURY, CONNECTICUT
 In Los Angeles, 411 West Fifth Street . . . In San Francisco, 235 Montgomery Street . . . In Seattle, 1338 Fourth Avenue



CERAMIC
 VENEER
 15"x24"

CHANDLER'S SHOE STORE • WILSHIRE BOULEVARD AT CLOVERDALE •
 JAMES P. MILLER, ARCHITECT • C. W. DRIVER, INC., GEN. CONTR. •

The adaptability of Ceramic Veneer as a facing material is demonstrated
 here in remodeling this two-story building.

In this modern design, the architect effectively combined yellow, brown,
 and grey bright glazes and utilized machine-made Ceramic Veneer even to the
 window sills and horizontal stripes. The field ashlar is 15"x24".



BEFORE MODERNIZATION

LADDING, McBEAN & CO.

MANUFACTURERS OF CLAY PRODUCTS

SAN FRANCISCO LOS ANGELES PORTLAND SEATTLE SPOKANE DALLAS VANCOUVER, B. C.



DETAIL, ERNEST INGOLD AUTOMOBILE DISPLAY AND SERVICE
BUILDING, SAN FRANCISCO
JOHN E. DINWIDDIE, ARCHITECT

MODERN TREND REFLECTED IN NEW AUTO SALES BUILDING

By JOHN EKIN DINWIDDIE



ERNEST INGOLD AUTOMOBILE DISPLAY AND SERVICE BUILDING,
SAN FRANCISCO, CALIFORNIA

John E. Dinwiddie, Architect

AN honest attempt to reconcile four sets of conditions—the peculiarities of the site, display and advertising possibilities, facilities, and the budget, characterized the design of the Ernest Ingold automobile display and service building, Van Ness Avenue, San Francisco.

Following the trend of design in this type of building, the service department received first consideration. This was planned for ease of entry and exit from side streets where traffic was less congested, and because of the uphill site this placed the main service floor on the

mezzanine level. Display of new cars, because of the dramatic advertising value of the site in the heart of San Francisco's "automobile row," was given more emphasis than is currently considered necessary, and was allotted the entire Van Ness front of the building, extending in height two stories. The rear of the first floor, under the mezzanine is largely underground, and is devoted to new car storage and preparation for display and delivery.

Auditing offices and bookkeeping occur on the mezzanine floor, partially separating the service department from the display rooms.



ENTRANCE, ERNEST INGOLD AUTOMOBILE DISPLAY AND SERVICE BUILDING, SAN FRANCISCO
John E. Dinwiddie, Architect

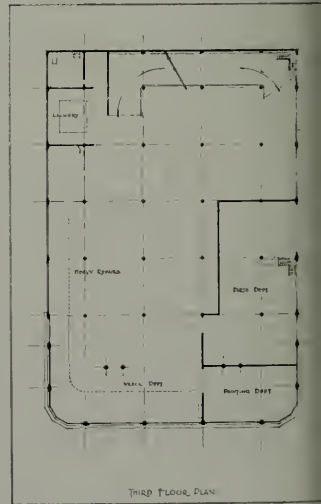
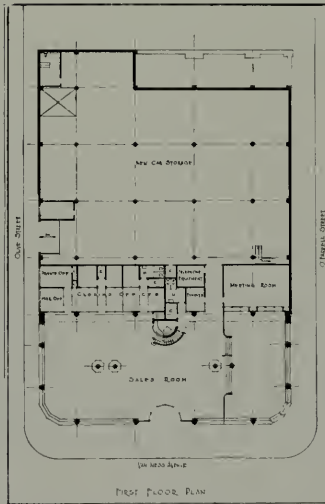
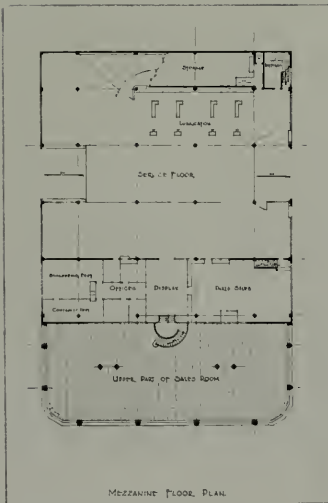

PLANS, ERNEST INGOLD AUTOMOBILE DISPLAY AND SERVICE BUILDING
San Francisco, California

Inasmuch as most people driving to the building would enter on the mezzanine level into the service department, an attempt was made to provide some display here, and to open the view into the sales room by means of glass partitions. Thus the customer coming in for service is provided an interesting display and comfortable place to wait, and is influenced to continue into the display room to inspect new models.

Likewise, prospective buyers are influenced to see the display on the balcony at the mezzanine level, and thus see the extraordinary facilities for servicing of cars. It has been found that the service facilities are of great importance in this respect, particularly where there are several agencies for the same car in the city.

The third floor is devoted to heavy repairs, painting and parts storage. The parts storage department occurs directly over the parts display on the mezzanine, thus bringing the parts department close to the three demands—customers, light repair and service, and heavy repair.

The roof is used as an overflow storage space, and is designed so that another floor may be added. Communication between floors is by ramp and stairs, elevators being considered uncertain because of the danger of shut-down through power failure.

The proper coordination of the foregoing conditions determined the entire design, and with the limitations of the budget careful selection of the most effective and economical materials was essential.

Reinforced concrete was determined by R. J. Fisher to be the most economical method of constructing a fireproof building. With this determined, the opportunity was seen to eliminate the corner columns on Van Ness, and open this for display.

The original plan called for columns 22 feet on centers with slab floors. This would have been satisfactory and allowed less floor to floor height. Mr. Ingold, however, felt that wider spacing would greatly facilitate the servicing, movement of cars, etc. The final spacing of columns, 27 feet on centers, was determined as

being the amount of space necessary for working comfortably on three cars between columns. This necessitated using beam and girder construction, increasing the cost somewhat.

All stairs are concrete except the circular stair to the balcony. It is interesting to note that many details originally planned for other materials, such as stairs, partitions, etc., were changed to concrete as being no more expensive on a concrete operation of this size.

Floor surfaces were designed for appearance and service. Agatex hardening and integral coloring were used throughout the building except in the display room and offices. In these rooms tile and carpet directly on the slab were used.

In the service portion of the building, plywood forms were used, giving a clean smooth surface that required only paint for finishing. Wherever possible the concrete was left exposed both for the sake of economy, and because the architect wished to develop the native beauty of the material where possible to do so. In those cases where veneers were necessary, they are frankly veneers with no attempt to suggest the strength or structural quality.

The exterior was left in concrete, plastered and waterproofed on wall surfaces. Columns were poured against plaster forms and all detail and ornament cast thus in place; the whole producing a simple and effective treatment. The advertising value of the facade accounts for the use of a rather dramatic application of detail.

The intercourse outside is of cast stone so nearly approaching granite in appearance as to deceive most people.

The interior of the sales room itself is further dramatized by the introduction of steel columns and girders which support the concrete of the second floor. The use of steel allowed the large span of forty-seven feet between the twin columns without loss of ceiling height.

On the whole it is an interesting example of what can be achieved trying to bring out the native beauty of simple materials simply used. It has proven its case in the sales value of the building and the extraordinary amount of business done since its occupancy.



SERVICE ENTRANCE TO ERNEST INGOLD AUTOMOBILE DISPLAY AND SERVICE BUILDING, SAN FRANCISCO

John E. Dinwiddie, Architect



VAN NESS AVE. FRONT, ERNEST INGOLD AUTOMOBILE DISPLAY AND SERVICE BUILDING, SAN FRANCISCO
John E. Dinwiddie, Architect



EXECUTIVE OFFICES, ERNEST INGOLD AUTOMOBILE DISPLAY AND SERVICE BUILDING, SAN FRANCISCO

John E. Dinwiddie, Architect



DISPLAY FLOOR, ERNEST INGOLD AUTOMOBILE DISPLAY AND SERVICE BUILDING, SAN FRANCISCO

John E. Dinwiddie, Architect



RUTH SCHOOL AUDITORIUM,
EL MONTE, CALIFORNIA

G. Stanley Wilson, Architect

GARDEN FRONT,
RUTH SCHOOL, ELMONTE, CALIFORNIA

G. Stanley Wilson, Architect



UNIFICATION OF THE ARCHITECTURAL PROFESSION

By HARRY M. MICHELSEN,

President, State Association of California Architects

UNIFICATION of the Institute and State Associations may be generally defined as a progressive procedure in establishing a strong background for the architectural profession through consolidating the individual groups into one great organization. Advancement in this direction has been restricted in the past, but due to the evergrowing complications that have become apparent in both private and public enterprises during the past several years, it has become recognized that a centralization of power is essential if we are to cope with these problems in the most efficient way.

ACCOMPLISHMENTS OF THE INSTITUTE

During its many years of existence the Institute has substantiated a profound sense of good fellowship among the architects of America, and has promoted the profession of architecture to a degree of respect and certainty for which it has become known as an organization of national standing. The betterment of conditions for the members, the maintenance of principles of ethics and integrity, and the equalization of fees may be considered of primary importance among the beneficial achievements that have resulted from years of effort and research. In general, it may readily be seen that the fair code of practice as established and followed by the Institute has favorably affected general business methods and professional standards, not only for those architects who are supporters of the Institute but also for those who have not had the opportunity to become acquainted with its many advantages.

PURPOSE OF STATE ASSOCIATIONS

The architects in a number of states have formed state organizations in order that municipal and state legislation, business practices, affairs pertaining directly to local architecture, and general civic activities, all of which are beyond the control of a national body, may be regulated to the best advantage of the greatest majority. Just as other trades and associations cooperate in obtaining their objectives, it is the desire of these local groups to have a united representation to bring into effect favorable conditions for the improvement of the architectural profession.

COMBINED ACTIVITIES OF BOTH GROUPS

It is clear that national affairs may be better coped with by the American Institute of Architects, and that local problems should receive the attention of the State Associations, but due to the constant evolution of business enterprises, difficulties have become evident that require a combination of state and national forces, in other words, an affiliation between the American Institute of Architects and the various State Associations. Unity in this sense should not be construed to mean that the state societies would relinquish their rights or become subservient to the Institute, but that both groups would work simultaneously for the best interests of the profession. The State Associations may be so organized as to represent the architects in city and state affairs and follow through with the Institute the national problems where they concern local activities. This ar-

rangement may give the impression of requiring a repetition of efforts on many subjects, which would not necessarily apply, as each group would have a distinct function to perform notwithstanding the close cooperation that is desired. With an added element of security and possessing strength and stability, this affiliation should prove to be a sound foundation upon which may be built a great organization that will be able successfully to meet the increasing demands of professional progress.

UNITY IN CALIFORNIA

The State Association of California Architects has for many years maintained a harmonious relationship with the Institute, and is hopeful that new and existing societies may be influenced to incorporate in their method of procedure similar principles that will encourage proficiency in the unification movement. Our Association is fully conscious of the need for centralization of efforts in undertaking to solve civic problems for the betterment of the building industry, and has without exception experienced quicker and more thoroughly effective results upon having worked in amity with the Institute. Convinced that a synonymous affinity between the Institute and other state organizations would likewise be efficient, we are anxious to introduce our system into other localities where state societies do not exist or where a smooth working organization is desirable. However, many different theories are expounded in other states, and since they are operating successfully in their own ways and it is conceded that each society shall enjoy independent rights under the direction of the Institute, it is not intended that their plans should be revolutionized to correspond with those of ours, but that they should be encouraged to proceed in forming rapid-functioning societies to promote greater congruity among the construction industry and others allied with architecture.

THE PRESIDENT'S ADDRESS

Mr. Charles D. Maginnis, president of the American Institute of Architects, delivered a very brilliant address at the Seventieth Annual

Convention held in New Orleans, expressing that the Institute has always been ready to extend its membership to those of ability and integrity who are willing to subscribe to a code of practice that was formed to protect the relations of the architects with the public. The activity of increasing the membership has been carried on by the local Chapters with due consideration to principles that would insure the Institute a continuity of professional ethics that are essential to the practice of architecture. His message eminently brought forth his desire that unification be given sincere consideration with the thought in mind that a friendly relationship may be established between the national group and the State Associations. This constitutes the belief of many members of the Institute who have over a period of years realized that the architects should be united in some form to protect their professional standards and objectives.

HISTORY OF UNIFICATION

Unification of the State Associations with the Institute was conceived more than ten years ago, and since then the subject has been studied by a committee authorized at the Convention in San Antonio in 1931, and further discussions followed in 1932 and 1934, resulting in the adoption of a resolution in favor of affiliation and approving in principle modifications pertaining to the duties of regional directors and the expansion of the Institute Chapters and the State Associations. Since the present policies of unification were approved at Milwaukee in 1935, continual advancements have been made.

There are now sixteen known State Associations, four of which are directly affiliated with the Institute, but in most groups the paid membership is approximately equally divided between Institute and non-Institute members, with the majority of officers and directors of State Associations being Institute members. This alone signifies the necessity for national and local groups to be organized to represent the architects in various business and professional activities.

FORMATION OF THE COMMITTEE

While state societies were being formed, the Institute was contributing further serious consideration to unification, and the Convention in the summer of 1937 at Boston, resolutions and recommendations were adopted for the formation of a new committee on state organizations, consisting of a chairman and members of the Institute from the existing state societies, irrespective of their affiliations with the Institute as it was considered important that each association should be represented in order to obtain the benefit of their ideas and experiences.

COMMITTEE'S PROGRESS

Under the leadership of Mr. John R. Fugard of Illinois, the committee on state organizations has been actively engaged during the past year in making an extensive investigation of State Associations; and based chiefly on the findings of this group, the discussion of unification was continued from previous conventions at the Seventieth Annual Convention of the American Institute of Architects held recently in New Orleans. Information gathered by the committee from sectional meetings and conferences throughout the nation disclosed that the architects who were unattached to the Institute were inclined to welcome the guidance and security of an organization that has been successful through its many years of existence. The progress made by conventions during the last few years was analyzed by the committee in a broad and unbiased way, and a complete report, embodying recommendations for the formation of new societies and the results of a research conducted in states where they already exist, was presented for discussion.

Since successful societies are known to be in effect in various localities, it is considered advisable and practical that similar ones should be formed throughout the nation. The forming of state organizations in itself is not where the difficulty lies, but affiliating them with the Institute presents certain complications inasmuch as the ideals of one state differ from those of another. However, facts uncovered by Mr. Fugard's committee seem to indicate that

either the ideals of existing societies or the general policies applying to new organizations would be effective in creating a favorable foundation upon which to build a substantial organization. It is of paramount importance that each group should realize that affiliation will not interfere with the enjoyment of state rights and that it is intended that independent operation will continue under the guidance of the Institute, with both organizations striving for greater accomplishments and for the betterment of the architectural profession.

MEETING OF STATE ASSOCIATIONS

Representatives of the State Societies met on Monday afternoon, April 18, with John R. Fugard presiding, to determine a precise method of presentation of their ultimate motives to the meeting of the Convention proper. Following an explanation of the committee's report, it was unanimously agreed that it would be advisable to coherently weld together the Institute with its Chapters, State Associations, unorganized practitioners, draftsmen, and others directly connected with architecture. The various working theories of the associations were presented, and Mr. Fugard commented on the organization of the Institute and the distribution of Chapters, stating that there seemed to be a necessity for an augmentation in the membership and a closer unity of the profession for effective power. Supplementing Mr. Fugard's call for an increase in the number of members, Richmond H. Shreve, one of the vice-chairmen of the committee, brought forth recommendations that the Institute urge an expansion in the Chapter form of membership, and that state societies be so reorganized as to effect a greater representation in the Institute, affiliation to be through the local Chapters instead of direct. Messrs. Tirrell J. Ferrenz, Arthur B. Holmes, Thomas Pym Cope, and others, further amplified the apparent need for an all-inclusive architectural federation to contend with both national and state issues, especially since other divisions of the building industry are well represented in numbers and are financially strong enough to attain their objectives.

Recommendations from California included that the affiliated associations be permitted a

larger representation at Institute Conventions and that there be appointed to the Institute Board a duplicate set of regional directors to represent each region's State Associations, which directors could vote only if all the societies in their respective regions are affiliated. Furthermore, it was suggested that the Institute should create a new office to be known as "State Association Secretary of the Institute," which would be maintained jointly by the Institute and the associations.

Publicity and revenue are essential in the maintenance of State Associations, and during the review attention was called to the mediums of magazines, report services, and the publication of building codes as being a partial source of financial income for California, Wisconsin, and Illinois. The success of the State Association of California Architects may be attributed to their interest and close cooperation in promulgating and developing the western publications and promoting a better report service, which activities have advanced the publications and report service to outstanding positions in their respective fields. Continuous publicity received by our Association and the building industry is invaluable toward establishing the requirements for powerful unification.

In approval of the committee's report, the Board of Directors of the Institute recommended the adoption of a resolution which in

substance included that the unification of the entire architectural profession in a single, strong, national body, without relinquishing any of the Institute's present professional authority, is essential to the success of future undertakings, and which provided that the by-laws and the charter be modified to create a directorship entitled "State Association Director," who shall be elected by the Convention of the Institute to represent the State Associations. The resolution was sanctioned, and Leigh Hunt of Wisconsin was nominated for the position of Director, which characterized the adjournment of the meeting.

RESULTS

On Thursday, April 21, Mr. Fugard presented the resolution to the Convention, and it was adopted by an enthusiastic majority.

The following day representatives of State Associations passed resolutions expressing their gratitude to the Institute and pledging their support and resources to assist Leigh Hunt in the formation of new state societies and in strengthening those in existence.

Since the Institute has contributed generous financial aid to developing the principles of unification, every architect should concentrate his energy and efforts towards building this federation into a strong and successful organization that will represent the architectural profession.



BUILDING FOR OWENS-ILLINOIS PACIFIC COAST COMPANY,
OAKLAND, CALIFORNIA

NEW NOTE IN INDUSTRIAL BUILDING DESIGN

FEW new industrial buildings have attracted more attention from both the architectural and engineering professions than the recently completed plant of the Owens-Illinois Pacific Coast Company at Oakland, California.

Modern in design and equipment, the plant offers many features of exceptional interest. The buildings are of reinforced concrete and steel and are equipped with a complete automatic sprinkler system. The exteriors are of clay and glass brick, the latter providing the maximum of properly diffused light.

The manner of handling the interior of the plant's office building has aroused much favorable comment. The attractive and useful combination of glass blocks and terra cotta wall units is exemplified in these interiors which express the most up-to-date manner for industrial installation. Here is shown a method by which machine-run terra cotta units of modern size and precision may be handled to successfully complement the modern glass blocks.

Partitions of glass blocks with wainscoting of terra cotta wall units, feature the interior which affords a maximum of perfect light, and attractive use of color along with other advantages. In certain of the partitions, Kraftile wall units were of a thickness of $3\frac{3}{4}$ inches and glazed on both sides. These were used as wainscots above which were placed glass blocks to make a finished wall in one operation, both the terra cotta wall units and the glass blocks being laid up by brick layers.

Glass blocks used were of the varying standard sizes, with flat surfaces and ninety degree curve units. Terra cotta wall units, of Kraftile, were of two sizes— 5×8 and $7\frac{3}{4} \times 7\frac{3}{4}$, and were precision sized with a tolerance not to exceed $1/16$ of an inch per lineal foot.



ENTRANCE VESTIBULE, OWENS-ILLINOIS PACIFIC COAST COMPANY
OAKLAND, CALIFORNIA

Showing exemplary use of glass blocks and tile for maximum utility and beauty of design



RECREATION ROOM FOR WOMEN EMPLOYEES, DONE IN KRAFTILE OF IVORY AND TWO SHADES OF GREEN

Below:
SAMPLE ROOM, OFFICE BUILDING OWENS - ILLINOIS PACIFIC COAST COMPANY, OAKLAND, CALIF.
Structural steel uprights are sheathed to match walls done in Unit tiles, pastel green in color.





General offices of the Owens-Illinois Pacific Coast Company, Oakland, Calif. Combination of glass blocks and tile afford abundant light and attractive coloring. Tile is new ivory above a wainscoting of light pastel green and baseboard of green in a darker tone.

I AM A STOCK PLAN BOOK

By L. S. SANDERSON, Architect

I AM a stock plan book. I am mature, prosperous and well established. Los Angeles has been my home for many years. I have numerous relatives elsewhere. My future is bright owing to the unique service I render. Whether good or bad is beside the point. I make my owner a profit—the supreme virtue of capitalism.

I am also mass production, for a single set of tracings will yield hundreds of blue prints. At \$10.00 per copy and extras for special orders, it runs into money.

In my youth architects brought my owner many customers. I served clients they had no interest in. I am circulated by lumber yards. They purchase me in small lots with their name on my cover for 25 cents. It pays them to give me to people they think likely to build because they can get more for their lumber selling it to contractors they finance, than to contractors that finance themselves.

Like the Phenix I rise rejuvenated from my own ashes annually. Largely for the profit I make as a new edition and secondly because no one has yet devised a style for a residence that has stuck.

Employing the carpenter's simple framework of two by fours, I have shown the way to represent everything from the moss covered cottages of Scotland to the latest modern inventions of plastered stripes and galvanized rails. With the optimism of a milliner and caution of a pawnbroker my owner overlooks nothing to make me the sigma of fashion.

Accumulated photographs are sifted for new facades of promise. Few builders ever object to my owner making photographs or notes of the houses they are building. Generally they regard it as a compliment and sometimes explain where they got this or that idea. A roof may have been seen in Glendale—the

porch at Long Beach, all depending of course on where the man lives and works. Some, more talkative than others, will offer the card of the salesman that sold them the combination porch posts and vine trellis for the modern north Hollywood colonial just completed across the street.

Such leads are valuable, for the boss can usually sell the factory an advertisement by having the draftsman feature their product on a snappy looking facade. If the boss runs across an occupied house that has promise of becoming what is known as a "Blue Ribbon Honey-moon Dream Home" the draftsmen can generally work out a floor plan from the photograph in models of from 4 to 7 rooms.

Until recent times I have been the work of ordinary folk. Today, however, I am pedigreed and blessed according to the latest laws and rulings. Formerly architects could poo-poo me for this and that defect. I was the work of laymen and therefore neither architecture nor engineering. Carpenters abused me too. I was not practical, sane or sound. But my blood was dyed blue with the legislation to make architecture the work of architects.

Today I furnish bread, and sometimes wine, to various licensed professionals. If one can not stand prosperity and boosts his price, there is always another to cut it. Men are like that, they can not be perfected by lawyers as readily as books like me—and with times as they are you can't blame a graduate for making at least one plan before taking up a career on a truck.

The satisfaction I derive from having many of my old best sellers retraced by a licensed man is great and fills a long felt want. I am no longer a poor layman's plan book. I am the new American Architecture from Coast to Coast—the lure and instrument of the largest mortgage debt yet written.



DETAIL OF ENTRANCE, SPRECKELS SUGAR
PLANT, NEAR WOODLAND, CALIFORNIA
Geo. W. Kelham, Harry A. Thomsen, Jr., Architects



ADMINISTRATION UNIT, SPRECKELS SUGAR REFINERY

SPRECKELS SUGAR PLANT AT WOODLAND, CALIFORNIA

By HARRY A. THOMSEN, JR.*

BECAUSE it is a great functional engineering unit, the plotting and layout of a sugar plant is no part of an architect's business practice. But a sugar plant can be, as other types of industry have found, an efficient array of machinery enclosed and sheltered in a pleasing structure. And that is where the architect, in recent years, has become increasingly important to industrial planning.

To process the great tonnage of sugar beets now produced in the Sacramento Valley, the Spreckels Sugar Company, pioneers in the development of beet sugar in America, has recently completed the most modern sugar factory in the world. Located at Woodland, California, near a great coast highway, Plant No. 3 gleams clean and white—a great symbolic sugar loaf against the green of the beet fields that surround it.

*Successor to the late Geo. W. Kelham, Architect, San Francisco. The architectural work in the building was started by Mr. Kelham and completed by the writer.

Spreckels' competent engineers designed the plant and then turned it over to the writer to develop the most pleasing exterior possible within the budget allowed. It was not an ordinary architectural problem. Because the layout of the machinery and the spaces surrounding it were necessarily flexible, the outlines of the structure were predetermined, and it was the duty of the architect to elevate the walls of the various units of the structure over these plans and to achieve whatever esthetic effects were possible.

It was immediately apparent that the dominant elevation feature of the structure would be the five concrete storage bins which were not only tall, but had definite form and, because they were to be concrete, possessed texture and color. Concrete, then, was the only material that would achieve uniformity in ap-

SPRECKELS SUGAR PLANT, NEAR WOODLAND, CALIFORNIA
Administration Unit in Foreground, Refinery in Rear. Huge Tanks on
the Left.

Note modern decorative treatment of office building. Six vertical
fins open curved reveals above entrance portico.

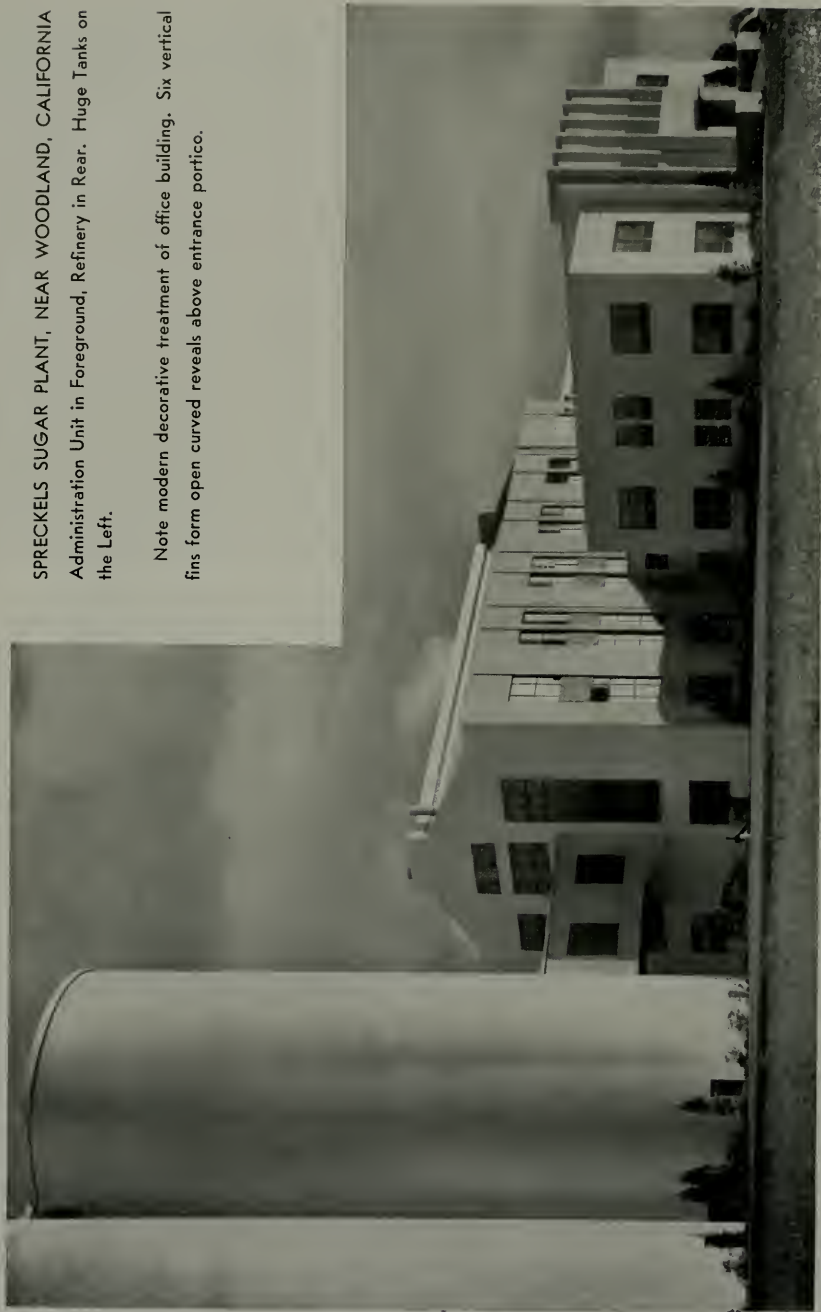



ANOTHER VIEW OF SPRECKELS SUGAR REFINERY,
SHOWING PARKING FACILITIES IN FOREGROUND

pearance, hence the entire structure naturally moved toward architectural concrete in the mind of the architect.

A further necessity in obtaining desired uniformity, was to make all the lines of the building as simple, direct and purposeful as the outlines of the bins. This turned out to be a splendid move, for in simplifying the structure, eliminating all but most essential monitors and penthouse structures, considerable sums were saved under the anticipated cost of the building.

The only pure decorative forms employed anywhere about the structure were confined to the administration unit which, because it stands far forward from the rest of the structure and presents an entirely independent facade, was suitable for such treatment. Here six vertical fins form open curved reveals and produce pleasing shadow effects by day and under floodlights at night.

Working effectively with the company engineers, the design was completed to the satisfaction of the owners and construction was started in October, 1936.

Wide shiplap forms were used for all plain wall surfaces with milled wood employed only

for shallow reveals and rustication lines. The final finish of the building was a stucco spatter dash in a buff shade which heightened the character of the walls and made all surfaces generally uniform in texture.

Immediately after opening, the plant went into full operation with day and night shifts, for during the sugar campaign tons of beets arrive daily and must be put into process as rapidly as possible.

In completing the Spreckels building superstructure, the work of the architect was not entirely finished, for he was asked to advise on interior color treatment, planting and night lighting. The use of aluminum paint on many of the large tanks inside was suggested to protect the equipment, to reflect light and to provide a pleasing, cheerful interior effect. The floodlights, some white and some amber, emphasize the architectural features and give the structure advertising value at night.

Architectural work on the project was started by the late George W. Kelham, architect of San Francisco, and completed by the writer. Dinwiddie Construction Co., of San Francisco, was the general contractor.



RANCH HOUSE, LAFAYETTE, CALIFORNIA
JOHN E. DINWIDDIE, ARCHITECT

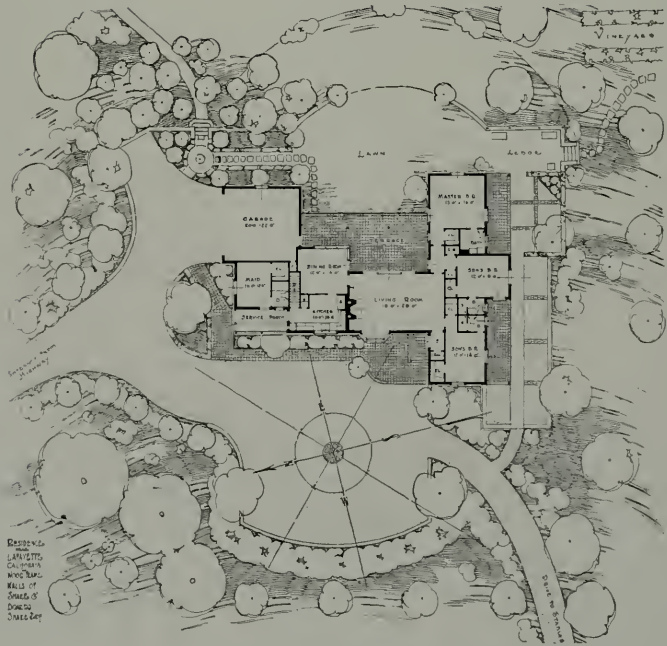

PLAN, RANCH HOUSE, LAFAYETTE, CALIFORNIA
JOHN E. DINWIDDIE, ARCHITECT

THE ARCHITECT AND HIS SHORT COMINGS

Should He Cater More to the Clients' Whims?

By FREDERICK HAMILTON

IN times of old there were great architects, probably pretty cranky fellows; perhaps the greatest of them all, Leonardo da Vinci, "handsome, tall, graceful, eager, affectionate, generous, an extraordinary athlete, horseman and fencer." Such were a few of his accomplishments besides being an inventor and an architect of surpassing skill.

In our own day we've had some pretty tall and nifty fellows too, clever and all that. Willis Polk, for example.

But our average isn't quite that kind, albeit not a few have the notion that were they not misunderstood, kept down by cruel fate, they, too, would be Leonardos.

Much has been written by architects themselves, and other enthusiasts, that would lead people to believe architects are more or less infallible and all quite "geniusy"—so to speak. And lately there have been literary efforts that extolled them so we've all grown a bit top-heavy. Long and profusely illustrated articles go so far as to deplore the stupidity of clients who will not let them, the architects, go wild, unrestrained, so that they can do really wonderful things, spend money lavishly and all that sort of flubdub. Indeed one article actually expresses great pain that the owner of a prospective building should have any special wishes or tastes or desires. The owner is looked upon as just a necessary evil, only to be tolerated. And most architects have fatuously come to believe the same silly thing.

* * *

Another author declares that all great architects are expensive architects; "wasters" some call them, and they are not great unless it be as bluffers. "Some architects have in-

sisted upon such absolute obedience that the client has not been granted a single whim." And again, "another architect is said to have even dictated what the lady who lives in one of his very original houses should wear!"

Yet the fact remains, get a lot of architects together and you'll find the conversation drifting into a discussion and lament as to their various clients, what tight-wads they are, low-brows, termagants, etcetra.

That attitude is their undoing. They feel that clients are a nuisance, are keeping them, (the architects) down, are selfish and unappreciative, enemies, and very soon that attitude has for reaction that the architect is giving less and less earnest service, his work suffers, people become more discontented with him, and his standing is lowered; people lose patience with him and more and more are dealing direct with building companies, buying ready made plans and trying every method to get away from any contact with the profession.

The architect, of course, does have some just cause for a few indictments against the average client, but the latter has just as many and greater ones against the average architect.

Client Swayed by Notions

Too often the client is swayed by silly notions; he gives the job to a lodge, club, church or bridge acquaintance, or to a relative and almost invariably gets stung. Proof of this is that mighty few people who build ever employ the same architect twice.

The only way to select an architect is to find one who has had experience in that particular line of building, who has a good record of accomplishment on a number of such buildings that have been finished within a rea-

sonable distance of his estimate of cost and time, and whose buildings are livable, well planned and artistic. Just how to go about finding such a man is something of a job in itself. It surely requires as much effort as is put forward in employing an executive officer in one's own bank or business.

The purpose of the building is decided upon before the architect is called in. It is very definite, it rarely is purely a monument, and generally is erected to produce revenue, or to house some special commercial plant, or as a home, or house of worship, whose occupants have especial needs or notions and limitations that should be catered to and served. His is the task of putting those ideas into reality, of producing that revenue, of making convenient and easy of operation that factory or school. Advantage must be taken of the site already selected or owned, consideration must be given to the surroundings. A perfect structure, with all its complexity of details and specialties, must be produced, and the whole must be kept within a limit of cost that has been prophesied, anticipated by the architect. On top of all that, if he be a true architect, he will make that building beautiful, whatever its purpose, whatever its cost, however humble it may be. And such a task elevates that work into the most ideal, the noblest, the grandest, the finest of the Fine Arts, and, without exception, the greatest and most complex of all the sciences. For it must take into account and actually comprehend at least the rudiments or some of the details of them all.

Architects are Inconsistent

Some offices turn out uniformly good work but, again, one building may be excellently designed and the very next one, by the same author, may sin in endless ways. Architects' sins are apparently not consistent nor habitual, they break out in unexpected places. The under-estimating habit, however, seems to be the most general and ingrowing. They know how many things the owner would like to have and they try to give them and probably hope against hope that they can achieve the impossible in getting something for nothing, and undoubtedly estimate and promise accord-

ingly, basing their calculations not upon facts, but hopes. It is a most ordinary sin to make plans that would cost to execute anywhere from thirty per cent to even one hundred and fifty percent more than the estimate, or the sum the owner has available for the investment. Cases are not infrequent where this underestimating has proven an absolute disaster to the owner, turning what was hoped to be a profitable investment into an initial and continual loss, a building that not only did not produce commensurate returns, but that could not be disposed of for anywhere near the amount invested, and all on account of either the architect's culpable lack of accurate information or his moral cowardice in not frankly telling the owner that neither he nor anyone else could possibly get him ten dollars' worth of building for six. And here it may be well to remark that an extra \$2,000 on an \$8,000 house is as important to the man who has skimped and saved for years to get the \$8,000 and has ONLY that, as is the \$150,000 or so extra to the bank or corporation that has figured its returns upon a \$1,000,000 investment.

What would you think of plans (most attractive looking plans and of a very well arranged house and artistic) so faulty that a beam crossed a main stairway so you would have to crawl under it: the framing so arranged that no door or window was provided to a very fine billiard room and lounge in an attic: and the two equal sides of a house figured so that one was nearly two feet longer than the other? And the architect wanted the owner to pay, as extras, the cost of all those plan blunders!

And here's another, a very fine club. The architect promised five stories of members' rooms, the real revenue-producing part of the building. Bids came in so high above his estimate he had to cut and instead of lopping off fine marbles inside and oodles of carved stone outside (frills) his only retrenchment was to slice off two stories of bed rooms!

Here's a week's work of a skilled adviser who passed on the run of a number of building projects that went through a Building Loan Company or Bond house shortly before the

depression. Eight percent cut off the bids on a big hotel and without impairing looks or space, just foolishness cut off and at that more than the entire cost of architect's service: 40% cut off the cost of the structural parts of a church and 13% off the total of another: an ugly building turned into a fairly attractive one without disarranging plans that were not at all bad: three rooms added to every floor of a tall apartment house and without additional cost, just that much more rent every year: a set of plans rescued from endless extras and fusses and two sets of plans passed on without suggestion of radical change. Changes could have been made but that would have been but one man's taste and judgment against another's, perhaps as good. The architects had done well and the results were satisfactory.

But that's about the ratio, two projects well handled out of eight. In fact its a rather high ratio. The year's average wouldn't touch it. But let it go as average.

Is the profession giving what it is supposed to be giving in service?

It would seem to be up to the architectural societies to encourage and help their members to a better understanding and appreciation of what they owe the public and their employers. Greater safeguards should be built around the profession so as to make it

harder to get into. There should be not only tests of ability but of character. More attention should be given to construction, plan-arrangement and costs, not at the sacrifice of ART but with ART as part of it all.

No art or science involves as many details, as much complex interweaving of specialties, and requires as masterly handling, far-seeing, almost prophetic, vision and wide information as does architecture. It is indeed the comprehending, the application of a hundred arts and crafts in one entity, and requires genius, skill, experience to handle it successfully. Few men in the profession have the native talent or have had the time or opportunity to perfect themselves, to be really thorough.

So let it be prescribed that architects should have longer and better training, an especial training in estimating.

And the owner, what of him?

He mustn't expect too much of an architect. He should make as sure as he can by every known business device to have his architect's efforts and especially estimates pass muster before some one qualified to so audit plans, and last but not least he should use intelligence, judgment, logic and lots of good common sense in selecting his architect. Then he can go ahead and build without fear and trepidation.



RESIDENCE OF MR. AND MRS. BLISS, NEAR SANTA MARIA, CALIFORNIA
L. W. CRAWFORD, ARCHITECT



COURT, RESIDENCE OF MR. AND MRS. ELISS, NEAR SANTA MARIA, CALIFORNIA
L. W. CRAWFORD, ARCHITECT



POST OFFICE BUILDING, REDDING, CALIFORNIA
ALBERT E. ROLLER, ARCHITECT

NEW FEDERAL BUILDING AT REDDING, CALIFORNIA

By HOMER N. HADLEY, C. E.

THE new Post Office at Redding, California, is another example of the simple yet pleasing and attractive small buildings which have been erected in considerable numbers in late years by the Public Buildings Branch of the U. S. Treasury Department. With only a limited amount of ornamentation and having neither pronounced breaks nor deep reveals, the building has a nicety of balance and proportion. It is simple, almost plain, yet reserve, dignity and character are evident. The design presents a most interesting solution of the old problem of accomplishing much with comparatively little.

The building is 114 feet by 72 feet in plan, one story and mezzanine. It has a basement under part of its area for boiler and fuel room. Its ground area is about 8,000 square feet with cubical content of 214,800 cubic feet.

The design is contemporary, executed in concrete with exterior walls a brushed finish above a rough wire brushed concrete base. Molded

panels, a small cornice and parapet walls of concrete continue around the building enclosing a flat roof. The principal front has vertical fluted pilasters between long metal spandrel windows. Basement walls, foundation, and floor slabs are concrete. The flat roof is of composi-

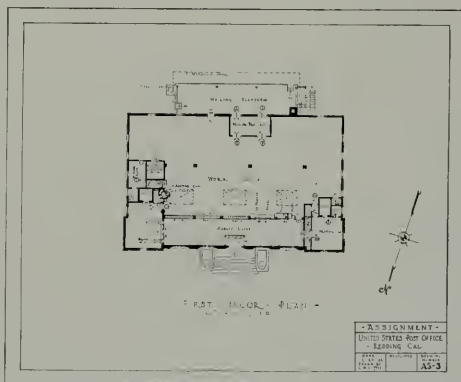

PLAN, POST OFFICE BUILDING, REDDING, CALIFORNIA
Albert F. Roller, Architect



DETAIL OF ENTRANCE, REDDING POST OFFICE BUILDING, REDDING, CALIFORNIA
ALBERT F. ROLLER, ARCHITECT

tion material on wood plank over steel framing. Exterior doors and windows are steel. Three skylights in this roof provide ventilation and abundance of light for the inside of the work room and counters behind the postal screen.

The concrete walls were poured in three sections using plywood for forms; first, to the top of water table; then to top of windows; and then to top of coping. The 22-foot pilasters without a horizontal break were poured in one section.

The interior public lobby has terrazzo floor, marble base, borders, and wainscot, wood trim, plaster walls, cornice and ceiling. The Postmas-

ter's office, entered from this lobby, has 275 square feet floor area. The mailing work room has 6,050 square feet of floor area and a financial section of 500 square feet back of the postal screen to serve the public. The mezzanine provides rooms for post office inspector, postal storage, and carriers' swing rooms.

The building was designed by Albert F. Roller, architect, of San Francisco, under contract with the Treasury Department for architectural services. The Public Works Administration authorized \$113,000 for the improvement. Dinwiddie Construction Company, San Francisco, were the contractors.

TRENDS IN HOME DECORATION

By MARY DAVIS GILLIES, Associate Editor *McCall's*

MODERNISM came into being as a reaction against the stuffiness of Victorian decoration. In Europe, principally Vienna and Paris, it came into life at the beginning of the 20th century. But nothing was heard of it here until 1925. The governing committee of the Industrial Arts Exposition in Paris at that time would only permit those designs to be shown which were wholly original and patterned on none of the old schools. As a result American designers had nothing to show. But they went over en masse only to be overwhelmed by the impact of the flat smooth surfaces and the new simplified approach to design.

Immediately merchandisers, store officials, furniture manufacturers, pursed their lips and said, "Tush, tush, now maybe this is a way we can revive the waning furniture industry!"

They came back and made stupendous preparations for the presentation of modern design in this country. In 1927 and '28 every big store up and down Fifth Avenue and, for that matter every big store in the country, had an exhibition of modern furniture, brought over piece by piece on the *Ile de France*. People came in droves to see it.

No furniture show in New York ever caused such a flurry and such heated debate as those first modern shows.

Grand Rapids and Chicago went to work on their new lines. They put the designers who had been copying period pieces all their lives into designing modern furniture and the results at the next market were pathetic. Still it was labeled modern. Modern had brought droves of people to furniture stores in New York so it was bought by buyers from Walla Walla, Washington and Albuquerque, New Mexico. But they

got it home and they didn't know what to do with it. The stuff looked terrible on the floor and it looked almost as bad stuck in one of the model rooms. People laughed at it, but they had had the good judgment not to buy it.

Modern Flops

After that first sad experience with modern, some manufacturers dropped it completely, but others listened to criticism and imported real modern designers to do their next line. Donald Deskey, Gilbert Rhode, Russel Wright, all did make contributions and for the first time in a hundred years the designer's name was linked with his furniture.

Some of the style leaders, some of we magazine people, clapped our hands at the next market but the depression had arrived and having been stung with their first modern furniture, buyers let alone this more intelligently designed second offering.

Then they tried the classic modern. It seemed to offer a method of creeping up on the public but it flopped. Finally along came the Century of Progress in Chicago in 1933. The best exhibits in the fair were the housing group which were for the most part modern in design and furnishing. Thousands of people came and for the first time the masses from the small towns of the middle west saw designed rooms. Rooms with furniture arranged logically, and color schemes that clicked.

So modern furniture began to sell, that is modern furniture for bedrooms. By 1935, approximately 35% of all furniture sold for bedrooms was modern. Another interesting feature was that modern furniture sold in only the high priced brackets or the specially designed stuff and in the very bottom brackets—really the borax field.

Abstract of a talk to the Home Economics Women in Business Group, Chicago.

As a matter of fact modern has made a contribution to the industry in almost shoving borax furniture off the map.

In July, 1935, modern furniture accounted for 24% of the furniture exhibited and borax furniture accounted for 23%. In January, 1937, modern furniture accounted for 34% of the case goods shown and borax for only 6%.

It's perfectly true a great deal of the modern furniture shown is so bad I want to close my eyes whenever I encounter it, but even so it's better than the old borax school.

Incidentally, how many of you know what borax furniture is? Well borax is the pet name the trade applies to furniture that just grows up like Topsy. It ain't got no mammy and it ain't got no pappy—it just isn't anything.

Modern Recovers

So now that modern has had the vitality to replace borax furniture it isn't intelligent to ignore it. It deserves a hearing and it deserves consideration even if you prefer traditional forms.

Modern design is an honest expression of this age and one that has developed from no mere whim. Throughout the ages the art of a period has reflected the thought and activity of the people.

Let's stop for a moment to analyze the thoughts behind the popular 18th century form. One needs no more than glance at Chippendale, Sheraton and Hepplewhite furniture to realize that a gracious age produced it, a period of manners, a period when women were ladies and dressed the part, when entertaining was a high art. Then observe the carving and the inlay work, the fine detail and you know that speed in manufacture and handwork was of no moment. Note the finish and you know that there were servants and plenty to keep it in shape.

This analysis is by no means an indictment of 18th century furniture but compare life then, with the hasty, unsocial life of today, with its labor problems, its servant problems, its mechanized mood. Is it possible that the furniture of that day could serve us ideally? Is it possible

that there is no furniture form more suitable to our small, cramped houses and low ceilinged rooms, our broader viewpoint?

There will always be traditionalists in design who are ancestor worshippers and who will devote their lives to it. But there are a growing number of vigorous young designers who with broad vision realize that new ways, new manners dictate new forms and that new materials and new tools make fresh forms possible. They thrill to steel, chromium, glass bricks, bakelite, flexwood, huge sheets of mirror glass and new woods. These are the designers who are going to revise our surroundings.

Today, even the thousands who express a distaste for modern design are accepting it in the home unconsciously. Automobiles, of course, are purely modern in detail today. But more than that, almost 95% of the kitchens which are built or modernized today are modern in design. 100% of refrigerator and range designs are modern—moreover they are designed by such men as Henry Dreyfus, Raymond Lowey, Lurelle Guild and equally well known men. Plumbing fixtures are modern. Pots and pans and small electrical appliances are modern. Cereal, coffee and dried fruits in modern packages designed by Egmont Ahrens sell better than old fashioned ones. Practically all clocks sold today are modern. Modern design has become something to reckon with in rugs.

Now even period furniture is used in a modern way. If by chance I wander into a room done in a pure period fashion I think I'm in a museum. It's stuffy.

The best decorators today are using fresh modern motifs, colors, upholstery and architectural features with beautiful old furniture. So don't condemn modern—it's here and it's here to stay in a constantly evolving and changing form.

A Look at Today

Now to take a more practical vein for a moment. You may select 18th century English mahogany furniture. But the chances are you may put it in a room with one wall painted yel-

(Please turn to Page 48)



San Francisco Terminal, Facing Mission Street, showing center unit under construction. Street car ramp in the foreground. East and west units not visible.

BUILDING BAY BRIDGE RAILROAD TERMINAL

SOON after the first of next year a three-quarter century old custom around San Francisco Bay will pass into history.

For the picturesque ferry boats which for decades have carried passengers between metropolitan Oakland and San Francisco will be replaced by smooth running electric trains plying across the San Francisco Bay Bridge.

Both Key System and Interurban Electric (Southern Pacific) will operate trains across the span at an average saving to passengers of 15 minutes.

Trains will operate directly from Alameda, Berkeley and Oakland to the terminal in San Francisco.

This structure, facing Mission Street and extending within the vicinity of Beale and Second Streets, will be longer than the Ferry Building, and will bring 50 per cent of the daily commuter traffic to within walking distance of their destination in San Francisco.

Street cars will loop in front of the terminal over an elevated ramp. The ramp will have three tracks, with a capacity of four cars each.

The terminal is a reinforced concrete structure to be faced with granite. To date, all structural concrete in the building units has been placed up to and including the track floor, the highest floor elevation in the project.

Above the track floor the side walls and roof slab are within 20 per cent of completion. All steel framing over the train shed, with the exception of the east unit, has been erected, and only steel construction for the viaduct remaining to be placed is that over South First and South Fremont Streets.

Because the Bay Bridge railroad will of necessity handle as many as 17,000 passengers one way at a twenty minute period over one track, close headway schedules will be required. Ten-car trains will run as close as 63 seconds apart. By way of comparison, New York subway trains have a 90-second headway.



Trains will roll in the San Francisco Terminal over six tracks arranged in pairs. View of the elevated track level.



Looking down the East Bay Crossing shows ties and tracks in place.

Illustrations courtesy California Highways and Public Works



Trains will leave westerly end of Bay Bridge over a viaduct paralleling the truck and "off" vehicular ramps

To assure maximum safety and efficiency, the most complete automatic interlocking and signal system has been designed

Replacing the old system of manually operated levers will be a trim control board, six and a half feet long and four feet and three inches high, designed so that the operator may sit before it as he would at a high-topped desk. Engraved on the face of the board is a track diagram with a signal knob or button placed at the entrance of each "route."

To "set up a route" the operator has only to press the signal knob at the entrance to the route and the completion knob at the exit to the route.

Such a control board will be installed in the San Francisco Terminal. The design on this board will show the six tracks over which bridge trains will roll to discharge and pick up passengers. On it will be indicated the 36 track switches and 40 wayside signals which comprise the interlocking plants of the terminal and viaduct.

A similar board will be placed in the high signal tower now completed in the Oakland yards situated just opposite the Toll Plaza. It will differ

only in respect to its diagram which will show a design of the yards comprising the storage tracks and the mainline tracks. The Oakland interlocking plant controls 36 track switches and 62 wayside signals.

Each train has its corresponding numeral or letter (numeral for Interurban Electric; letter for Key System) identified on the board. When the train leaves either terminus the operator presses the proper button identifying the train to the operator at the other terminus.

Trains will loop into the San Francisco Terminal from the bridge over a viaduct, so insulated as to eliminate noise to the greatest possible degree.

The trains will leave and enter the lower deck of the bridge at a point west of and paralleling the truck and "off" vehicular ramps.

East and westbound trains will share a common viaduct between the bridge and Clementina Street at which point the viaduct separates to form a gigantic loop which will encompass the approximate equivalent of seven city blocks. San Francisco-bound trains from this connection take an easterly to westerly curve into the Terminal.



Where Bay Bridge trains will enter and leave the easterly end of the span.

All foundations for the viaduct are practically completed, as is the neat work on the piers. The concrete crossing over Harrison is finished, and other crossings are rapidly nearing completion.

On the bridge proper, the trains will ply over two tracks on the south side of the lower deck, paralleling the truck lanes.

California redwood has been selected for the ties. On the bridge proper the ties are laid directly on the stringers, after the steel had received two coats of inertol.

Each tie is dapped at either end. Ties are marked according to their position on the roadbed and enter the dapping machine in precise relation to the order in which they will be laid on the bridge. The depth of the dap is determined by the stringer, which has been previously surveyed, and upon this depth is also determined the elevation of the track. Depths vary from one-quarter inch to one and one-quarter inch. The dap in most cases is eleven inches wide.

A total of 150,000 ties or approximately 7,000,000 board feet of California redwood comprise the tie order for the Bay Bridge railroad. This is said to be the largest individual order made on the Pacific Coast in a decade.

The running rail is a 90-pound rail, in 39-foot sections. The guard rail is a 90-pound relay. On the main bridge and San Francisco loop the running rails will have a total gross tonnage of 1830; the guard rails, 1315 and the contact rail (to be used by the Key System only) a gross tonnage of 1400 pounds.

The Key System, which now operates on 600 volts, will continue to do so over the bridge. The Interurban Electric will continue to operate on 1200 volts as at present over a catenary system.

An approximate total of 400,000 spikes weighing 160 tons will be used for the tracks on the main bridge alone.

Trim steel catenary bridges painted aluminum, are replacing the timber trolley poles used by the trains at present. Erection of the catenary bridges has been completed.

WORLD'S FAIR BUILDERS — ERNEST E. WEIHE

THEY left it to Architect Ernest E. Weihe to create the "first impression" of the Golden Gate International Exposition in the minds of the millions who will go there next year, sailing out to Treasure Island aboard a ferry, or rolling around the bend of the broad highway on Yerba Buena.

Since Architect Weihe likes best of all to work in monumental masses, and to do it playfully when possible, the main entrances and facade on Treasure Island will say "Pageant of the Pacific" to these millions. They will say it with a gay flourish of trumpets containing more than a trace of swing-music, for an Exposition entrance shouldn't look like a mausoleum entrance. It should be—and it is—alluring.

The elephants help, standing up there fourteen stories high with their traditional flavor of foofaraw and "big doings." The setback pyramids help, for this most stable of geometric forms has been shaped somehow to rise from a substantial base toward a frolicking skyline that whets the appetite for inside. The vermilion floodlighting, when the Fair gets going, will help, by pulling attention and feet toward the turn-stiles.

For a World's Fair that aims to be the Pageant of the Pacific, and to pull millions through the turnstiles, this is all good stuff, and Weihe did it. He began working at architecture in San Francisco offices in 1907, and his first experience with a mad-house was as an employee of the Panama-Pacific International Exposition Company in 1912 and 1913.

A more tranquil career with Bakewell & Brown from 1913 to 1919 gave him further opportunity to get his hand into Panama Pacific Exposition buildings. In 1918 Weihe took his diploma from the Beaux Arts Institute of Design of America; the next year he won the National Competition for the Paris Prize, and



ERNEST E. WEIHE—called the "Front Door Planner" for the Golden Gate International Exposition.

from 1920 to 1923 he studied at the Ecole des Beaux Arts in Paris.

Back with Bakewell & Brown in 1923, he entered partnership with John Bakewell upon dissolution of the older firm in 1927. Weihe's thought, in association with John Bakewell and Arthur Brown, Jr., has crept into various building of the Stanford University campus from 1927 to the present.

In the list of masonry that bears the Bakewell & Weihe touch are found the Balboa High School and Phoenix Assurance Company buildings in San Francisco; the George Wagner, Walter Sullivan, Dr. A. Lincoln Brown and Joseph Bransten homes, also in San Francisco; and the homes of Lindsay Howard at Hillsborough, Norman B. Livermore at Ross, and Lydia Hopkins at Woodside.

Since the horse, in these days, is a rarified animal of considerable social significance, an architect is justified in sharpening any number of pencils over the design of a stable. The neat stables of Frank and Dana Fuller at Beresford, and of John Rosekrans at Woodside, are products of sharpened Bakewell & Weihe pencils and architecturally speaking, at least, they have no flies on them, as the old phrase went.

In addition to all of which, Mr. Weihe is a member of the American Institute of Architects and the Society of Beaux Arts Architects. He likes long discussions about weighty topics better than anything except architecture providing the discussions can be held sitting down and in architecture he likes monumental pieces better than anything except group planning. For group planning, see Stanford.

All these things went along, and now Mr. Weihe is a member of the Architectural Commission of the 1939 Golden Gate International Exposition. His share of Treasure Island—the main entrance towers and western facade of the walled city—is nearly completed, except for the life-giving touches of color, horticulture and illumination. It can speak for itself now, almost as clearly as it will speak to millions next year.

It speaks in a polyglot medley of Oriental tongues, for this is a Pacific Fair. It speaks with considerable zip-tarara-boom-de-ay about it, for educational marvels are all very well but you go to World's Fairs to have fun. It's a swell

front door, because it beckons you through into the living room, the kitchen, and especially the rumpus room.

TRENDS IN HOME DECORATION

(Concluded from Page 42)

low and the other three grey; you may have a modern grey textured rug on the floor and loose woven modern yellow draperies shot with grey at the windows.

Again you may choose American, Colonial, Federal or Empire furniture, simpler versions of the 18th century English school. You may get very loving hands and homey and get exact reproductions of chintzes and rugs, possibly some used at Williamsburg, an important style influence of the moment. But nine times out of ten you will have a modern radio in that room, a modern heating system, modern electric lights and perhaps modern machine turned woodwork.

Again you may turn to maple. If you do I warn you, get either pure Early American design with the new rubbed finish or the extreme modern type in blond finish. Beware as of the plague of the in-between clubby stuff. However, even with reproduction maple, modern details inevitably creep in.

Then for something different you can turn to Provincial, Victorian or Regency furniture. As a matter of fact, good Queen Ann, bow legs and all, is coming back into circulation. It's a new note.



STONE CLOISTER OF A SUMMER
HOME NEAR LAKE TAHOE



CHESLEY BONESTELL'S CONCEPTION OF THE GOLDEN GATE
INTERNATIONAL EXPOSITION AT NIGHT

Pacific Coast Architects' Chapters

NORTHERN CALIFORNIA CHAPTER

The regular meeting of Northern California Chapter, A.I.A., was held May 10, at the University of California, in observance of the annual "University Night." The meeting was convened at 6:30 with Warren C. Perry presiding and Ernest E. Weihe, acting secretary.

The following were present: Harris C. Allen, John Knox Ballantine, Jr., Will G. Corlett, John J. Donovan, Albert J. Evers, Henry H. Gutterson, Wm. C. Hays, Lester Hurd, Raymond W. Jeans, Thomas J. Kent, Lawrence A. Kruse, Charles F. Masten, Chester H. Miller, Irving F. Morrow, Harry A. Michelsen, Howard Moise, Gwynn Officer, Warren C. Perry, Ernest E. Weihe, Alfred C. Williams, Wm. Wilson Wurster, Ralph Wyckoff.

In addition to the Chapter members there were present as guests the members of the School of Architecture of the University, architectural alumni, members of the newly formed Society of California Draughtsmen and newly certificated architects. The combined attendance amounted to 82.

Harold W. Hawes, president of the Society of California Draughtsmen, was introduced. He expressed the desire of his group to encourage close cooperation with the Chapter and with draughtsmen's employers.

Harris Allen, architectural consultant of the Federal Housing Bureau, gave a short outline of the work his Bureau has scheduled for the near future.

There followed reports by delegates to the annual Institute Convention at New Orleans. Mr. Wyckoff gave an account of the first day's proceedings, Mr. Evers the second day's, and Mr. Michelsen the third day's.

Regret was expressed at the absence of Mr. Meyer and Mr. Mitchell.

After adjourning the group proceeded in traditional manner to the "Ark" where the annual scholastic awards were made to the students of the school. Mr. Donovan graciously presented the awards on behalf of the Institute.

The remainder of the evening was passed in viewing the excellent exhibition of student work.—J. H. M.

OREGON CHAPTER

At the May 17th meeting of Oregon Chapter, President Howell requested that all Chapter members who wish to contribute photos and drawings of their work to be published in the special Oregon number (July) of THE ARCHITECT AND ENGINEER, send same to Glenn Stanton on or before June 1st. Mr. Stanton has

been appointed guest editor of this number by the San Francisco publication.

New associates, including Ben Smith of the City Building Department, were introduced by the secretary.

President Howell asked ex-regional-director Crowell to report to the Chapter on the New Orleans Convention. Mr. Crowell regretted the absence from this meeting of his fellow delegate, Morris H. Whitehouse, who had promised to attend to give an account of the lighter side of the activities in New Orleans, including Sazerac cocktails. Mr. Crowell reported that the retiring Board of Directors had passed a resolution favoring a return to a Tax and Refund system for equalization of delegates' expenses, this recommendation to be acted upon by the new Board in November. He advised Chapter to continue agitation for this measure through his successor, Robert K. Fuller of Denver. Mr. Crowell further reported on the convention activities in regard to State Associations, Housing and Competitions and then gave an impassioned account of old Louisiana plantations, the levees and the miasmatic beauty of the bayous.

Mr. Logan reported for the exhibition committee on the forthcoming exhibition of travel sketches of Hal Onstad to be held at Meier & Frank's in July.

Mr. Doty read a letter addressed to Allison Dean by special committee Sundeleaf, Morin and Doty, protesting Mr. Dean's architectural activities.

Mr. Herzog reported as favoring draft of new Plumbing Code as written, and in spite of objections from Mr. Morin it was moved and passed that the Chapter endorse Mr. Herzog's approval. Mr. Herzog further reported on draft of proposed new Plastering Code, and registered opposition to sections on licensing and issuing separate permits. It was moved and passed that the Chapter go on record as opposing these sections and that remainder of draft be turned over to Linn Forrest for further study, to report to the Executive Committee at the next meeting.

An account was given of a dinner tendered William Lescaze of New York at the University Club recently and attended by Messrs. Johnston, Brookman, Belluschi, Stanton, Church, Doty, Pipes, Tucker and Morin. Mr. Lescaze expressed himself strongly in favor of competitions.—R. L. M.

WASHINGTON STATE CHAPTER

Passage of an enabling act by the next Legislature authorizing cities to take advantage of the Federal Housing Act was discussed by the Washington Chapter, A.I.A., at a dinner meeting May 5 in the New Washington Hotel, Seattle. About 60 members attended the

meeting at which President B. Marcus Priteca presided.

John T. Jacobsen gave a comprehensive report on recent Federal Housing and National Housing Authority legislation. A summary also was given of the research work done by the Seattle mayor's committee on housing.

The business session devoted considerable discussion to the proposed formation of a state association of architects to include all those having licenses. Advantages gained by such an association in California were cited.

Thirteen students and faculty members from the School of Architecture, University of Idaho, were guests.

F. H. A. BUILDING INDUSTRY DINNER

The F. H. A. has asked the cooperation of the building industry in publicizing the recent amendments to the Housing Act, under which provision is made for insurance for large scale housing loans insured through the banks. The original F. H. A. program under which smaller home construction has been insured through the a great help to home building and the two new amendments will assist greatly in heavier construction for multi-family dwellings. It is possible that many millions of dollars worth of new private work can be promoted in Northern California through the two new sections. Same are as follows:

Section 207, under which F. H. A. insures mortgages financing large scale housing projects for loans up to \$5,000,000.

Section 210, under which F. H. A. insures mortgages for housing projects, for 10 or more families where the cost is between \$16,000 and \$200,000.

The Building Industry Conference Board composed of the organizations of architects, engineers, Associated General Contractors, Central California Chapter, and the Producers' Council, held an informal dinner on Wednesday, June 1, at the Mart Club in the Furniture Exchange, San Francisco.

Many organizations connected with the industry, including various loan agencies, were represented. Speakers, well informed on all details of obtaining loans under these two amended sections and on recent rulings made by F. H. A. in Washington, were introduced, followed by an open forum.

BERKELEY Y.M.C.A. BUILDING

Contracts have been awarded for a 2-story frame and stucco branch Y.M.C.A. building in West Berkeley to cost \$25,000. W. H. Ratcliff, of Berkeley, is the architect.

SPANISH STYLE RESIDENCE

A Spanish style residence of 18 rooms and 10 baths will be built near Guerneville for William D. Frisbee, from plans by Eldredge T. Spencer, 369 Pine Street, San Francisco.

HAROLD H. WEEKS BUSY

New work in the office of Harold H. Weeks, 503 Market Street, San Francisco, includes an addition to the gymnasium, library, cafeteria and swimming pool of the San Benito County High School District, Hollister, \$90,000; addition to the San Martin Grammar School auditorium, \$14,000; science building and auditorium for the Ceres Union High School District, \$167,000; addition to Pleasant Hills Grammar School, Walnut Creek, \$20,000; building for the Rockridge United Brethren Church, Oakland, \$40,000; classrooms, auditorium and gymnasium for the Oakley Grammar School District, \$50,000; classrooms for the Orinda Grammar School District, \$50,000.

SHASTA DAM

Shasta Dam, for which bids were opened recently by the Bureau of Reclamation in Sacramento, will be the second largest concrete dam in the world, both as to height and mass. Its only rivals will be mighty Boulder Dam, completed by the Bureau on the Colorado River, and Grand Coulee Dam, under construction by the Bureau on the Columbia River.

A comparison of the designed size of these three water conservation giants follows:

	Shasta Dam feet	Boulder Dam feet	Grand Coulee Dam feet
Height	560	727	553
Crest length	3,500	1,282	4,200
Base thickness	580	660	520
	cu. yds.	cu. yds.	cu. yds.
Concrete	5,610,000	4,360,000	10,250,000

An allegorical picture of Shasta Dam is a mass of masonry higher than San Francisco's Telephone Building, as long as the distance up Market Street from the Ferry Building to the Palace Hotel, as thick at the base as the distance between Market and Mission Streets. The dam will be taller than Los Angeles' City Hall, Fresno's Pacific-Southwest Building or Seattle's Smith Tower, and twice as tall as the California State Capitol in Sacramento. It will require concrete enough to build a solid monument an average city block square and slightly higher than New York's Empire State Building.

Second to Boulder in height and second to Grand Coulee in mass, Shasta Dam will be first in at least one respect—as the highest overflow type of dam in the world. Water falling over the 375-foot spillway in the center of Shasta Dam will have a drop of 480 feet, which is three times the height of Niagara Falls.

Bids for building the dam were opened June 1 with Pacific Constructors, Inc., of 609 South Grand Avenue, Los Angeles, a syndicate of 12 contracting firms, the low bidder at \$35,939,450.

One other bid was submitted, by the Shasta Construction Company, of 1,000 Balfour Building, San Francisco, a syndicate of nine firms, at \$36,202,357.

With the Architects

OFFICERS OF STATE BOARD

At the May 17 meeting of the California State Board of Architectural Examiners held in Los Angeles, the following officers were elected:

Harry J. Devine, President of the State Board and of the Northern District Board.

A. M. Edelman, Secretary-Treasurer of the State Board and of the Southern District Board.

Harold E. Burket, Vice-President of the State Board, President of the Southern District Board.

Frederick H. Reimers, Assistant Secretary-Treasurer of the State Board, Secretary-Treasurer of the Northern District Board.

The Northern District Board also wishes to announce the removal of its office from 450 McAllister Street, to Room 208, 515 Van Ness Avenue, San Francisco, the phone number remaining the same, UNderhill 8700.

CERTIFICATES TO PRACTICE

The State Board of Architectural Examiners has called in provisional certificates and issued state certificates to practice architecture to the following: Geoffrey N. Lawford, Gene H. Brockow, Roy W. Cheesman, Francis J. Heusel, Norman N. Kandl, Walter B. Phillips, Frederic Bortzmeyer, John S. Butler, Cabell Gwathmey, John P. Clark, Rowland H. Crawford, Jerome C. De Hetre, Arthur R. Doggart, Julian F. Everett, Philip C. Fisk, Arthur Freehlich, Joseph R. Kelly, W. George Lutz, Arthur C. Metcalf, Robert B. Morrison, Lowell N. Pidgeon, Nelson P. Rice, Lloyd A. Ruocco, Burton A. Schutt, Allastair Simpson, Harold R. Smith, George N. Sprague, and J. Warren Wright.

RESTAURANT AND STORES

Douglas D. Stone, 381 Bush Street, San Francisco, has completed plans for a one-story frame and stucco restaurant building at the Golden Gate Fair Grounds for Crillo. Estimated cost is \$20,000. The same architect has let a contract for remodeling the store at Sutter & Powell Streets, San Francisco. Chester N. Weaver, owner.

HOTEL, PASO ROBLES

Working drawings are in progress in the office of Hertzka & Knowles, architects, 369 Pine Street, San Francisco, for extensive remodeling and landscaping at the Paso Robles Hot Springs Hotel. Later on the building is to be completely equipped with a fire sprinkler system.

BURLINGAME APARTMENTS

Five four-room apartments will be erected on El Camino Real, San Mateo County, for Anton Rulfs, from plans by E. H. Denke, 1317 Hyde Street, San Francisco. Improvements will cost \$25,000.

PERSONAL

Percy G. Ball is now unofficial mayor of Redondo, King County, Washington, according to Architect **Silas E. Nelsen**, Tacoma, with whom he is associated in practice.

Floyd A. Naramore, and **Clifton J. Brady**, until recently PWA engineer examiner in charge of Washington State PWA architectural projects, have formed a partnership for the practice of architecture under the firm name of Naramore & Brady. They will have offices in the Central Building, Seattle.

Anne G. Rockefeller, who came to Tucson, Arizona, 43 years ago after graduation from Massachusetts Institute of Technology, served two years as a member of the faculty of University of Arizona, and then embarked in practice of architecture, has retired from business and taken up her residence at Santa Barbara. She was the designer of El Conquistador hotel, La Fonda Buen Proceha, Safford school and the Tucson Y.W.C.A. building.

Arthur H. Adams, former city engineer of Long Beach, has been appointed public works engineer of Los Angeles County, succeeding Charles Clark.

Russel Ray of Pasadena has moved his architectural offices from 170 E. California Street, to 1140 S. Pasadena Avenue, Pasadena.

E. Keith Lockard, of Santa Barbara, has formed a partnership for the practice of architecture with **Roy W. Cheesman**, Dayton, Ohio, who came to Santa Barbara on a visit and decided to remain permanently. Mr. Cheesman is a graduate of the College of Architecture of Cornell University. He had practiced in Dayton since 1925.

Louis Selden announces the removal of his offices to larger quarters at 854 S. Robertson Boulevard, Los Angeles.

FEDERAL APPOINTMENT

Richard J. Neutra, San Francisco and Los Angeles, is one of eight architects appointed by the Secretary of the Treasury to serve as a jury in competitions for plans for new Federal postoffices. Prizes totaling \$19,000 have been offered by the Treasury Department.

For the ten best drawings for small postoffices to cost \$50,000 each, prizes of \$1,000 each are offered. Prizes of \$3,000, \$2,000 and \$1,000 are offered for the three best designs for a \$450,000 postoffice and courthouse at Covington, Kentucky, in a competition to close July 26.

With the first prize a salary of \$3,000 will go to the winner as consultant on specifications.

COMPETITION JURY

The Museum of Modern Art announces that the Wheaton College (Norton, Mass.) competition for designs for a half-million-dollar art center will be judged by a jury composed of the following: Dr. Walter Curt Behrendt, architect; John Wellborn Root, architect, Chicago, member of Holabird and Root, one of the best known architectural firms in the United States; Edward Stone, architect, New York, associated with Philip Goodwin on design of new building for the Museum of Modern Art; Roland Wank, architect, Principal Architect, Department of Regional Planning Studies, Tennessee Valley Authority; Stanley R. McCandless, lighting and theater consultant; John McAndrew, Curator of Architecture, Museum of Modern Art, and Esther Isabel Seaver, Ph. D., Professor of Art, Wheaton College, Norton, Mass.

George Nelson, Associate Editor of the Architectural Forum is Professional Adviser in the competition which closed at midnight Tuesday, May 24. Of the 460 architects who signified their intention of entering the contest, 243 submitted designs.

RESIDENCE WORK

Ed Munson Sharpe, 111 Sutter Street, San Francisco, has completed drawings for a two-story frame and stucco residence in Burlingame for H. B. Rucker; also the same architect has awarded a contract for a two-story stucco house at Woodside costing \$16,000 for L. M. G. Peterson, 520 Bowdoin Street, Palo Alto.

SKETCHES AND WORKING PLANS

Frank Wynkopp, Haberfelde Building, Bakersfield, has prepared sketches for an auditorium and cafeteria for the Delano Joint Union High School District. The same architect has working drawings in progress for remodeling a frame residence into a physicians' office and apartment for Dr. Harry Lang, Bakersfield. Estimated cost is \$10,000.

BOTTLING PLANT CONTRACT

A contract has been awarded for the construction of a rectifying and bottling plant for the Schenley Products Company, 415 Montgomery Street, San Francisco. The building will be located at Battery and Vallejo Streets, San Francisco, at a cost of \$150,000. W. D. Peugh, is the architect.

SONORA THEATER

Harvey Amusement Company, 291 Golden Gate Avenue, San Francisco, has had plans prepared by Frederick W. Quandt, Phelan Building, San Francisco, for a reinforced concrete theater with a seating capacity of 1000 to be built in Sonora at an estimated cost of \$45,000.

INCAN AND MAYAN ART

One of the finest exhibits of the art and culture of ancient Peru ever shown in America will be presented at the 1939 Golden Gate International Exposition, according to Exposition officials.

Collections from the old civilizations of South and Central America will be included in the Division of Pacific Cultures exhibit under Dr. Langdon Warner, director of the Fogg Museum.

Wendell C. Bennett, curator in the field for the American Museum of Natural History in New York, has been appointed field curator for the Pacific Basin show of the \$50,000,000 Pageant of the Pacific. Bennett, who is now doing field work high in the Mountains of Peru, will return to Lima next July to take active charge of assembling the San Francisco Exposition's Peruvian display.

The main collection for the Peru exhibit will come from the Inca civilization, which in its heyday included more than a million square miles of territory. The majority of the material, which will come from private collections and government loans, was found in the vicinity of Cuzco, ancient capital of the Incas.

Excellent examples of pottery, fine gold and silver work, glass and precious jewelry, fabrics and stone and wood carvings will be included in the Exposition exhibit. In metal work the Peruvians were the most advanced of all early American peoples. They discovered the process of smelting metal from the ore, the art of making bronze, and the use of conical ore furnaces. They were also skilled workers in stone and wood.

From the Mayas will come some fine pieces of architectural stone carving. Among the objects expected to be shown at the World's Fair of the West are several lintels, stone monuments, a complete ceremonial altar, and intricately carved stone columns.

ENGINEERS FORFEIT CHARTER

Because of disagreement over membership regulations, Los Angeles Chapter of the American Association of Engineers has surrendered its charter, according to E. H. Clarkson, Jr., Pacific Coast director of the national organization. The local group will continue, however, as the Engineers' and Architects' Association of Southern California, the original name, with the same officers headed by Gerald Marsac as president.

SYMMES AND WILLARD BUSY

New work in the office of Symmes & Willard, Bakersfield, includes an auditorium for the Bakersfield School District costing \$175,000; school building for the Panama School District, \$55,000; auditorium and gymnasium at McFarland, \$80,000; auditorium and gymnasium, Shafter, \$48,000; and store building for the Pioneer-Allen Company.

ARCHITECTS' BULLETIN

Issued For

THE STATE ASSOCIATION OF CALIFORNIA ARCHITECTS
Northern Section

STATE ASSOCIATION MEMBER
OF THE
AMERICAN INSTITUTE OF ARCHITECTS

Editor

Harris C. Allen

Address all communications for publication
of the Bulletin to the Editor (Harris C.
Allen) 557 Market Street, Room 218, San
Francisco, California.

Board of Control

Harris C. Allen
Otto G. Hintermann
M. Michelsen
Ellsworth E. Johnson
Chester H. Miller

State Association Officers

M. Michelsen, San Francisco, President
D. Riddle, Los Angeles, Vice-Pres.
N. Crawford, Santa Maria, Secretary
O. G. Hintermann, San Francisco, Treas.

Regional Director, A. I. A.

Albert J. Evers, San Francisco

Representative of Regional Director,
Southern California

Gordon B. Kaufmann, Los Angeles

Executive Board—Northern Section Officers

M. Michelsen.....President
N. Crawford.....Vice-President
Ellsworth E. Johnson.....Secretary
O. G. Hintermann.....Treasurer

Directors

Ernest E. Baumberger William G. Merchant
J. Devine Frederick H. Reimers

Executive Board—Southern Section Officers

D. Riddle.....President
G. B. Kaufmann.....Vice-President
N. Crawford.....Secretary
H. H. Orr.....Treasurer

Directors

W. C. Chambers Lester G. Hibbard
W. P. Edelman W. P. Lodge
S. B. Marston

Advisors—Northern Section

Harris C. Allen Edward R. French, Jr.
M. Ashley Arthur F. Dodman
Ballantine Joseph Losekann
H. S. Hertzka David H. Horn
Ed T. Kett Robert Stanton
Garren Charles S. McKenzie
G. Merchant Henry C. Collins
H. E. Pring Leo J. Sharps
H. Raney Carl F. Gromme
H. Reimers C. C. Dakin
W. O. Blodgett F. T. Georgeson
G. P. Simonds Ralph D. Taylor
H. Orr

A. I. A. CONVENTION

PRESIDENT MICHELSEN, Delegate of the S. A. C. A. to the Institute Convention at New Orleans, has submitted a very complete and interesting report of the arguments and actions which concerned State Organizations. To make a brief digest of the report, the Convention voted (practically unanimously) to continue and strengthen the system of affiliation between State Associations and the Institute, and to create a new office of "State Association Director" to represent the State Associations on the A. I. A. Board of Directors. This resolution, embodied in the report of the Committee on State Organizations, was seconded by Delegate Michelsen (with appropriate remarks) who also moved, as the sense of the Committee meeting, that "recommendations of the Regional Director for State Associations to the Board of the American Institute of Architects on matters of policy between the Institute and state associations should be based on the response of the majority of such societies replying within 30 days of his inquiry." The full resolution, as adopted, is as follows:

"WHEREAS, the unification of the entire architectural profession in a single strong national organization representing numerically the architects of the country is essential; and

"WHEREAS, the Institute has always been the leader in professional organization and will continue as such; and

"WHEREAS, the present form of affiliation of state societies has not proven itself sufficiently attractive to the state societies; and

"WHEREAS, the Institute should relinquish none of its present professional authority, but should aim to increase its prestige by so changing its form as to represent and organize and unite in fellowship all qualified architects; and in order to further the uniting of all unorganized architects into state societies; now, therefore be it

"RESOLVED, that the Seventieth Convention of The American Institute of Architects directs the Board to prepare changes in the by-laws and charter of the Institute necessary to create a new office of Director, to present them to the Seventy-first Convention for adoption. The holder of the new Directorship is to be titled 'State Association Director,' whose status shall be similar to that of Regional Director, whose term of office shall be two years, who shall represent the state associations on the Board, who shall be nominated by such associations and elected by the Convention of the Institute."

Leigh Hunt of Wisconsin was nominated by the committee and appointed by the Board of Directors, to serve as the new State Association Director until next year's Convention. Mr. Michelsen says that we are fortunate in this choice, both for Mr. Hunt's personal qualifications and because the Wisconsin and California forms of association are similar.

A sub-committee to formulate plans for new State associations was appointed by Mr. Fugard (chairman of the A. I. A. State Organization Committee) on which a member from California is to be chosen by our Executive Board. The Institute is adding \$1000 to the sum of \$450 remaining from last

year's appropriation, to be used at the discretion of the committee and the new Director.

It was announced that Alabama and Texas have recently formed State Associations and are looking forward to affiliation with the Institute.

S. A. C. A. OFFICE

The Old Trouper's motto is "No matter what happens, the show must go on." Even though our indispensable and omnifarious office secretary, Miss Kragen, is to take a well deserved vacation from June 17th to July 5th, there will be a substitute secretary at the office every morning, during Miss Kragen's absence, to attend to the Association business. If unable to give any particular information desired, she will refer the question to someone on the Board.

Architects are again reminded of the valuable registration service for draftsmen which the Association conducts. Our office should be the first place to apply when draftsmen are needed, as a very complete register is kept of persons available, with records of their training and experience.

COMPETITIONS

Notices have been received at the Association office of two international competitions to which our members are invited. One is for the best preliminary plan for a new university in San Salvador, with prizes of \$1500 and \$500; rules and information may be procured from Jorge Ramirez, Consul General of El Salvador, San Francisco.

The other is for a monument to Jose Marti in Cuba, with prizes of \$10,000, \$5,000, \$2,000, five prizes of \$1,000 and "Ten Honorific Mentions and Diplomas." A book of information is on file at the Association office. The monument is to be a "free architectural and sculptural conception to be devoted, in addition to representing the physical or symbolic figure of Marti, (called the Apostol and Martir of the Struggle for Liberty which culminated in Cuba's independence) to a Martinian Library and Museum." Cost of the monument is to be from \$500,000 to \$600,000, including the author's fee. The competition will close October 8, 1938, with the Jury's decision October 30. The book may be consulted at our office or at the Cuban Consulate in San Francisco, where J. J. Zarza is Consul.

ERRATA

A typographic error was made on page 52, April issue, The Architect and Engineer, FHA Construction Requirements under "Applications"; reference should be to Northern California Property Standards, Circular No. 2, Par. VI (not IV).

RECORD MONTH FOR PERMITS

The largest number of permits credited to a single day in the history of the Los Angeles city building department was 408 issued on Monday, May 2. The previous high record for a single day was 406 permits issued in October, 1923.

WINS PHELAN TRAVELING SCHOLARSHIP

Arthur Brown, Jr., President of the San Francisco Art Association, has announced award of the 1938 Phelan Traveling Scholarship of \$2000 to Miss Una McCann, painter.

Miss McCann is 25 years old. Though born in Redwood City, California, she was reared on the Monterey Peninsula, having attended elementary and high schools at Pacific Grove.

During her elementary school years she started sketching the Italian Fishermen at Monterey. During high school a special arrangement was made whereby she spent her art periods sketching out-of-doors, for which she received school credit. No members of her family have been artists.

She first enrolled in the California School of Fine Arts in August, 1932. She has studied life drawing with Lee Randolph, life drawing and painting with Maurice Sterns, sculpture with Ralph Stackpole, lithography with Ray Bertrand and fresco with Victor Arnautoff.

The San Francisco Museum of Art exhibited her collection of bridge drawings in June, 1936. The same collection was later shown at Gelber Lillienthal Galleries.

The Phelan Traveling Scholarship is limited to present students of the California School of Fine Arts who have completed two consecutive years of study, and who are under 30 years of age. Provision was made for this scholarship under the terms of the bequest left the San Francisco Art Association by the late Senator James D. Phelan. The California School of Fine Arts is a non-profit school operated by the San Francisco Art Association.

Through persistence, physical endurance and courage Miss McCann has the only chronological graphic story of the building of the Oakland Bay Bridge and the Golden Gate Bridge. She devoted her entire time for over a year sketching and painting all the operations which went into the construction of these structures. Her hundreds of sketches remain the only visual intimate history of the bridges in the making.

CRANE COMPANY MOVIE

Several hundred architects and engineers attended the informal meeting given on April 28 by Crane Company under the auspices of the Producers' Council Club of Southern California. Open house was held at the Crane Company exhibit rooms on Highland Avenue, Los Angeles. J. F. Gehring, president of Producers' Council Club, presided and the guests were welcomed by D. D. Updegraff, manager of the Los Angeles branch of Crane Company.

A feature of the evening was the showing of a sound motion picture entitled "Flow" which depicted and explained the precision manufacture of Crane products. It was stated the Crane Company manufactures more than 42,000 items of valves, fittings, plumbing fixtures, etc., which are important to modern civilization.

Structural Engineers Association of Northern California

OFFICERS

Harold B. Hammill, President

S. S. Gorman, Vice President

H. M. Engle, Secretary-Treasurer

Other Directors:

F. F. Hall

A. V. Saph, Jr.

ENGINEERS HOLD ANNUAL OUTING AT PHELAN ESTATE, SARATOGA

By HYMAN ROSENTHAL, Structural Engineer

THE Structural Engineers Association of Northern California held their annual picnic on Saturday, June 4, at Villa Montalvo, near Saratoga, California. Grounds of the old Phelan Estate were graciously opened for the event by the San Francisco Art Association.

Plans for the picnic had been prepared for weeks in advance by Milo S. Farwell and William E. Emmett, registered picnic engineers. Farwell received his early training at Ohio Wesleyan. He did graduate work at the University of Heidelberg, the Sorbonne, and the University of Bologna, home of the famous boloney. Emmett wrote his masters' thesis on "The Elastic Properties of the Welded Sandwich," in which he developed a theory which has provoked wide discussion.



Engineer Bley (sitting) appears to be feeling none too well, which explains the consultation going on between the three men in the foreground, Engineers Gould and Adrian and Architect Beutner.



The East Bay Charlies (Whitton and Bley) whetting their appetites.

One hundred and twenty members of the Association, friends and relatives turned out for the groundbreaking ceremonies, which were held from 10:00 a. m.

to 8:30 p. m., roughly speaking. The ceremony consisted of a brief address of welcome to each arriving carload of merrymakers. The speeches were delivered over a public address system by anyone standing near the microphone. The guests then dispersed to (a) go swimming, (b) walk around the spacious and beautifully-landscaped grounds, or (c) introduce Junior to a few of the boys from Papa's office.

Following the discovery by many of the picnickers of three kegs of beer and unlimited quantities of soda pop, preliminary work on construction began. For this,

it was necessary to let a general contract for the destruction and/or removal of large quantities of lunch, which cluttered up the site on which actual construction was planned.

After luncheon, Professors Wells and Thomas of Stanford University were appointed Garbage Engineers. None of their students was present to object. After deep thinking they developed a brand-new system of garbage removal, called the "Let-George-Do It" plan. The garbage contract was let to Gus Saph and a corps of assistants, who worked, as expected, with a maximum of efficiency.



Former President Saph, Sub-contractor on Garbage Collection, and his office assistant.

As work progressed, Program Engineer Howard Schirmer stepped into the picture with a corps of consultants. Schirmer directed a horse-shoe tournament, baseball game and miniature track meet. The baseball game was notable for the crushing defeat of a team led by Sunshine Gorman. It required only one other team and an umpire to do this.

Other happenings of the day: Mr. and Mrs. Stan King brought lunch for a whole bevy of bachelors, some genuine and some imitation; Mr. and Mrs. J. B. Leonard brought their wire-haired fox terrier, Bob; President Harold Hammill reportedly delivered the shortest speech made by any President since Calvin Coolidge. The speech: "What fun."

S. F. CIVIL ENGINEERS ACTIVE

Francis T. Letchfield, consulting engineer and assistant vice-president of Wells Fargo Bank, will be guest speaker at the meeting of the Section at the Engineers Club Tuesday evening, June 21, at 6:00 o'clock. Mr. Letchfield will talk on the subject "Back Stage in Europe's Industries." He is well qualified to discuss

this subject as he recently returned from France, England and Germany where, as one of twenty-five American scientists, he was privileged to visit forty-six European research laboratories. On account of the present stage of international relations this talk will be of intense interest to Section members and to the general public.

AUGUST AND OCTOBER MEETINGS

The Sanitary Committee will have charge of the technical program for the August meeting and the October technical program will be sponsored by the Committee on Soil Mechanics and Foundations.

EXCURSION TO BE ANNOUNCED

J. G. Bastow, chairman of the Excursion Committee, expects to arrange a trip to the San Francisco terminals of the Interurban Railroad of the San Francisco Bay Bridge during the latter part of June.

JUNIOR FORUM

The Junior Forum held its last meeting on Tuesday evening, May 17, at California Inn, Turk and Polk Streets, San Francisco. Present were some twenty-eight members of the Forum and A. V. Saph representing the senior section of the A.S.C.E.

"Should All Construction Projects Be Economically Sound?" was the topic for general discussion, and brought forth spirited comment from the members present.

The paper for the evening was delivered by W. T. Corum of the U. S. Forest Service, and dealt with the floods of early March in Southern California. His talk was accompanied by slides and illustrations dealing with the floods.

SO. CALIFORNIA STRUCTURAL ENGINEERS

The regular monthly dinner meeting of the Structural Engineers Association of Southern California was held at the Clark Hotel, 426 South Hill Street, Los Angeles, May 4, seventy-five members and guests being present.

Sidney F. Bamberger, Jr., Am. Soc. C. E., Chairman of the Junior Group, reviewed a paper by Leon H. Nishkian, M. Am. Soc. C. E., Consulting Engineer, San Francisco, which was read before the Seismological Society. It was entitled: "Why a Constant Seismic Factor for Buildings?"

Clarence J. Derrick, M. Am. Soc. C. E., Consulting Engineer, Los Angeles and also a member of the Structural Engineers Association of Northern California, read the paper he had prepared and presented before the Seismological Society entitled: "Some Hypotheses for a Rational Method of Earthquake Loadings."

W. G. LENGENHEIM

William G. Lengenheim, classmate of the late Joseph B. Strauss, noted bridge engineer, and associated with him on many of his engineering projects, died in Los Angeles May 18, aged 67 years. He had been living here since he retired from professional practice four years ago.

Estimator's Guide

Giving Cost of Building Materials, Wage Scale, Etc.

Amounts given are figuring prices and are made up from average quotations furnished by material houses to San Francisco contractors. 3% Sales Tax on all materials but not labor.

All prices and wages quoted are for San Francisco and the Bay District. There may be slight fluctuation of prices in the interior and southern part of the state. Freight charge, at least, must be added in figuring country work.

Laid—1 1/2% amount of contract.

Work—

Common, \$40 to \$45 per 1000 laid, (according to class of work).

Face, \$100 to \$110 per 1000 laid, (according to class of work).

Brick Steps, using pressed brick, \$1.25 lin. ft.

Brick Veneer on frame buildings, \$.75 sq. ft.

Common f.o.b. cars, \$14.00 at yard. Cartage extra.

Face, f.o.b. cars, \$45.00 to \$50.00 per 1000 carload lots.

FOLLOW TILE FIREPROOFING (f.o.b. job)

3x12x12 in.	\$ 84.00 per M
1x12x12 in.	94.50 per M
1x12x12 in.	126.00 per M
3x12x12 in.	225.00 per M

FOLLOW BUILDING TILE (f.o.b. job)

carload lots.	
1x12x5/2	\$ 94.50
1x12x5/2	73.50

Building Paper—

ply per 1000 ft. roll	\$3.50
ply per 1000 ft. roll	5.00
ply per 1000 ft. roll	6.25
townskin, 500 ft. roll	4.50
townskin, Pro-tect-o-mat, 1000 ft. roll.....	9.00
townskin, 500 ft. roll	5.00
ash cord com. No. 7	1.20 per 100 ft
ash cord com. No. 8	1.50 per 100 ft
ash cord spot No. 7	1.90 per 100 ft
ash cord spot No. 8	2.25 per 100 ft
ash weights, cast iron, 350.00 ton.	
ash, \$3.50 base.	
ash weights, \$45 per ton.	

Concrete Work (material at San Francisco bunkers)—Quotations below 2000 lbs. to be ton. \$2.00 delivered.

No. 3 rock, at bunkers.....	\$1.45 per ton
No. 4 rock, at bunkers.....	1.45 per ton
Cliffert top gravel, at bunkers 2.10 per ton	
Washed gravel, at bunkers....	1.45 per ton
Cliffert top gravel, at bunkers 2.10 per ton	
City gravel, at bunkers.....	1.45 per ton
river sand, at bunkers.....	1.40 per ton
delivered bank sand.....	1.00 cu. yd.

Re—Above prices are subject to discount of 2% per ton on invoices paid on or before the 10th of month, following delivery.

ND
Del Monte, \$1.75 to \$3.00 per ton.
en Shell Beach (car lots, f.o.b. Lake Matella), \$2.75 to \$4.00 per ton.

Cement (paper sacks) \$3.00 bbl., warehouse or delivery.

Car-load lots delivered \$2.70, f.o.b. cars \$2.52

(Cloth sacks) \$3.00 bbl.,
Rebate 10 cents bbl. cash in 15 days.

Atlas White } 1 to 100 sacks, \$1.50 sack,
Calaveras White } warehouse or delivery; over 100
Medusa White } sacks, \$1.25; 2% discount 10th of month.

Forms, Labors average \$40.00 per M.
Average cost of concrete in place, exclusive of forms, 35c per cu. ft.;

with forms, 60c.

4-inch concrete basement floor
.....12/2c to 14c per sq. ft.

Rat-proofing7/2c
Concrete Steps\$1.25 per lin. ft.

Dampproofing and Waterproofing—

Two-coat work, 20c per yard,
Membrane waterproofing—4 layers of saturated felt, \$4.50 per square.

Hot coating work, \$1.80 per square.
Medusa Waterproofing, 15c per lb., San Francisco Warehouse.

Tricocul waterproofing.

Electric Wiring—\$12.00 to \$15.00 per outlet for conduit work (including switches).

Knob and tube average \$3.50 per outlet.

Elevators—

Prices vary according to capacity, speed and type. Consult elevator companies.

Average cost of installing an automatic elevator in four-story building, \$2800; direct automatic, about \$2700.

Excavation—

Sand, 60 cents; clay or shale \$1 per yard.
Teams, \$12.00 per day.

Trucks, \$22 to \$27.50 per day.
Above figures are an average without water. Steam shovel work in large quantities; less hard material, such as rock, will run considerably more.

Fire Escapes—

Ten-foot galvanized iron balcony, with stairs, \$115 installed on new buildings; \$140 on old buildings.

Floors—

Composition Floors—22c to 40c per sq. ft. in large quantities. 16c per sq. ft. laid.

Mosaic Floors—80c per sq. ft.
Duraflex Floors—23c to 30c sq. ft

Rubber Tile—50c to 75c per sq. ft.
Terrazzo Floors—45c to 60c per sq. ft.

Terrazo Steps—\$1.60 lin. ft.

Hardwood Flooring (delivered to building)—
1 1/2x2 1/4" T & G Maple.....\$ 88.00 M ft.
1 1/2x2 1/4" T & G Maple115.00 M ft.
7/8x3 1/2" sq. edge Maple.....100.00 M ft.

	1 1/2x2 1/4"	3/4x2"	5/8x2"
	T & G	T & G	5q. Ed.
Clr. Old. Oak	\$120.00 M	\$ 82.50 M	\$110 M
Sel. Old. Oak	95.00 M	69.50 M	84 M
Clr. Pla. Oak	106.00 M	74.50 M	86 M
Sel. Pla. Oak	97.00 M	62.50 M	76 M
Clear Maple	111.00 M	100.00 M	
Laying & Finishing	14c ft.	12c ft.	10c ft.
Wage—Floor layers, \$10.00.			

Note—Above quotations are all board measure except last column which is sq. ft.

Glass (consult with manufacturers)—
Double strength window glass, 20c per square foot.

Plate 75c per square foot (unglazed) in place, \$1.00.

Art. \$1.00 up per square foot.
Wire (for skylights), 40c per sq. foot.

Obscure glass, 30c square foot.
Glass bricks, \$2.40 per sq. ft., in place.

Note—If not stipulated add extra for setting.

Heating—

Average, \$1.90 per sq. ft. of radiator according to conditions.

Warm air (gravity) average \$40 per register.
Forced air, average \$60 per register.

Iron—Cost of ornamental iron, last iron etc., depends on designs.

Lumber (prices delivered to bldg. site).

No. 1 common	\$29.00 per M
No. 2 common	27.00 per M
Select O. P. common	34.00 per M
2x4 No. 3 form lumber	24.00 per M
1x4 No. 2 flooring VG	55.00 per M
1x4 No. 3 flooring VG	47.00 per M
1x6 No. 2 flooring VG	60.00 per M
1 1/4x4 and 6, No. 2 flooring	60.00 per M

Slash grain—

1x4 No. 2 flooring	\$43.00 per M
1x4 No. 3 flooring	40.00 per M
No. 1 common run T. & G.	30.00 per M
Lath	5.25 per M

Shingles (add cartage to price quoted)—

Redwood, No. 1	\$1.10 per bdle.
Redwood, No. 290 per bdle.
Red Cedar	1.10 per bdle.

Millwork—Standard.

O. P. \$85.00 per 1000. R. W., \$90.00 per 1000 (delivered).

Double hung box window frames, average with trim, \$6.50 and up, each.

Doors, including trim (single panel, 1 1/4 in. Oregon pine) \$8.00 and up, each.

Doors, including trim (five panel, 1 1/4 in. Oregon pine) \$6.00 each.

Screen doors, \$3.50 each.
Patent screen windows, 25c a sq. ft.

Cases for kitchen pantries seven ft. high per lineal ft., \$8.00 each.

Dining room cases, \$8.00 per lineal foot. Rough and finish about 75c per sq. ft.

Labor—Rough carpentry, warehouse heavy framing (average), \$17.50 per M.

For smaller work average, \$35.00 to \$45.00 per 1000.

Marble—(See Dealers)

Painting—

Two-coat work	36c per yard
Three-coat work	50c per yard
Cold Water Painting	10c per yard
Whitewashing	4c per yard
Turpentine, 65c per gal., in 5 gal. cans, and 55c per gal. in drums,	
Raw Linseed Oil—97c gal. in bbls.	
Boiled Linseed Oil—\$1.00 gal. in bbls.	
Medusa Portland Cement Paint, 20c per lb.	

Pioneer or Dutch Boy White Lead in Oil (in steel kegs)

1 ton lots, 100 lbs. net weight	10 1/4c
500 lbs. and less than 1 ton lots	10 1/2c
Less than 500 lb. lots	11c

Pioneer or Dutch Boy Red Lead and Litharge (in steel kegs)

1 ton lots, 100 lb. kegs, net weight	10 1/4c
500 lbs. and less than 1 ton lots	10 1/2c
Less than 500 lb. lots	11c

Pioneer Red Lead in Oil (in steel kegs)

1 ton lots, 100 lb. kegs, net weight	11 1/4c
500 lbs. and less than 1 ton lots	11 1/2c
Less than 500 lb. lots	12c

Note—Accessibility and conditions cause some variance in costs.

Patent Chimneys—

6-inch	\$1.25 lineal foot
8-inch	1.75 lineal foot
10-inch	2.25 lineal foot
12-inch	3.00 lineal foot

Plastering—Interior—

1 coat, brown mortar only, wood lath	80
2 coats, lime mortar hard finish, wood lath	80
2 coats, hard wall plaster, wood lath	85

3 coats, metal lath and plaster	1.30
Keene cement on metal lath	1.30
Ceilings with 3/4 hot roll channels metal lath plastered	1.50
Ceilings with 3/4 hot roll channels metal lath plastered	.85
Single partition 3/4 channel lath 1 side 2 inches thick	1.50
4-inch double partition 3/4 channel lath 2 sides	1.30
4-inch double partition 3/4 channel lath 2 sides plastered	3.00

Plastering—Exterior—

2 coats cement finish, brick or concrete wall	\$1.00
2 coats Calaveros cement, brick or concrete wall	1.35
3 coats cement finish, No. 18 gauge wire mesh	1.50
3 coats Calaveros finish, No. 18 gauge wire mesh	1.75

Wood lath, \$7.50 to \$8.00 per 1000.	
2.5-lb. metal lath (dipped)	.17
2.5-lb. metal lath (galvanized)	.20
3.4-lb. metal lath (dipped)	.22
3.4-lb. metal lath (galvanized)	.28
3/4-inch hot roll channels, \$72 per ton.	
Finish plaster, \$18.90 ton; in paper sacks.	
Dealer's commission, \$1.00 off above quotations.	
\$13.85 (rebate 10c sack).	

Lime, f.o.b. warehouse, \$2.25 bbl.; cars, \$2.15	
Lime, bulk (ton 2000 lbs.), \$16.00 ton.	
Wall Board 5 ply, \$50.00 per M.	
Hydrate Lime, \$19.50 ton.	

Plasterers Wage Scale	\$.125 per hour
Lathers Wage Scale	\$.125 per hour
Head Carriers Wage Scale	\$.110 per hour
Composition Stucco—\$1.80 to \$2.00 sq. yard (applied).	

Plumbing—

From \$70.00 per fixture up, according to grade, quantity and runs.

Roofing—

"Standard" tar and gravel, \$6.50 per sq. for 30 sqs. or over.	
Less than 30 sqs. \$7.00 per sq.	
Tile, \$20.00 to \$35.00 per square.	
Redwood Shingles, \$7.50 per square in place.	
Copper, \$16.50 to \$18.00 per sq. in place.	

Cedar Shingles, \$8.00 per sq. in place	
Recoat, with Gravel, \$3.00 per sq.	
Asbestos Shingles, \$15 to \$25 per sq. laid.	
Slate, from \$25.00 to \$60.00 per sq. laid according to color and thickness.	

Sheet Metal—

Windows—Metal, \$1.75 a sq. foot.	
Fire doors (average), including hardware \$1.75 per sq. ft.	

Skylights—(not glazed)

Copper, 90c sq. ft. (flat).	
Galvanized iron, 30c sq. ft. (flat).	
Vented hip skylights 60c sq. ft.	

Steel—Structural

\$120 ton (erected), this quotation is an average for comparatively small quantities. Light truss work higher. Pa. beams and column work in large quantities \$90 to \$100 per ton.

Steel Reinforcing—

\$80.00 to \$120.00 per ton, set.

Stone—

Granite, average, \$6.50 cu. foot in place	
Sandstone, average Blue, \$4.00. Base \$3.00 sq. ft. in place.	
Indiana Limestone, \$2.80 per sq. ft. in place.	

Store Fronts—

Copper sash bars for store fronts, come center and around sides, will average 75c per lineal foot. Note—Consult with agents.

Tile—Floor, Weinscot, etc.—(See Dealers)
Asphalt Tile—18c to 28c per sq. ft. in stalled.

Venetian Blinds—

40c per square foot and up. Installed extra.

THE BUILDERS' EXCHANGE OF SAN FRANCISCO STANDARD WAGE SCALE

For mechanics employed on construction work in the Bay Region. Effective September 1, 1937

CRAFT	Journeymen Mechanics	CRAFT	Journeymen Mechanics	CRAFT	Journeymen Mechanics
Asbestos Workers	\$ 8.00	Laborers, Building (8h-5d)	\$ 6.00	Steam Fitters (8h-5d)	\$11.00
Bricklayers (6h-5d)	10.50	Laborers, Common (8h-5d)	6.00	Stair Builders (8h-5d)	9.00
Bricklayers' Hodcarriers (6h-5d)	6.75	Lathers, Channel Iron (6h-5d)	9.00	Stone Cutters, Soft and Granite (8h-5d)	8.00
Cabinet Workers (Outside) (5d)	8.00	Lathers, All Others	8.00	Stone Setters, Soft and Granite	12.00
Coisson Workers (Open)	6.40	Marble Setters (8h-5d)	10.50	Stone Derricksmen	11.00
Carpeners (8h-5d)	10.00	Marble Setters' Helpers (8h-5d)	5.00	Tile Setters (8h-5d)	9.00
Cement Finishers (8h-5d)	10.00	Millwrights	9.00	Tile Setters' Helpers (8h-5d)	6.50
Cork Insulation Workers (8h-5d)	9.00	Model Makers (\$1.50 per hr-6h)	12.00	Welders, Structural Steel Frame on Buildings (10h)	9.00
Electric Workers (8h-5d)	10.00	Modelers (\$2 per hr-6h)	12.00	Welders, All Others on Buildings	9.00
Electrical Fixture Hangers	8.00	Metal Casters	7.20	Dump Truck Drivers, 2 yards or less	7.00
Elevator Constructors	10.40	Mosaic and Terrazzo Workers (Outside)	9.00	Dump Truck Drivers, 3 yards	6.50
Engineers, Portable & Hoisting	9.68	Painters (7h-5d)	8.50	Dump Truck Drivers, 4 yards	7.00
Glass Workers (8h-5d)	9.00	Painters, Varnishers and Polishers (Outside)	9.00	Dump Truck Drivers, 5 yards	7.50
Hardwood Floormen	9.00	Pile Drivers and Wharf Builders	9.00	Dump Truck Drivers, 6 yards	7.50
Housesmiths, Architectural Iron (5hsp) (8h-5d)	9.00	File Drivers' Engineers	10.00	Truck Drivers of Concrete Mixer Trucks: 2 yards or less	6.50
Housesmiths, Architectural Iron (Outside) (8h-5d)	10.00	Plasterers' Hodcarriers (6h-5d)	10.00	3 yards	7.00
Housesmiths, Reinforced Concrete or Rodmen (8h-5d)	10.00	Plumbers (8h-5d)	11.00	4 yards	7.50
Iron Workers (Bridge and Structural) Including Engineers (8h-5d)	12.00	Roofers, Composition (8h-5d)	9.00	5 yards	7.50
		Roofers, All Others (8h-5d)	8.00	6 yards	8.00
		Sheet Metal Workers (8h-5d)	10.00		
		Sprinkler Fitters	10.00		

GENERAL WORKING CONDITIONS

- Eight hours shall constitute a day's work for all crafts except as otherwise noted.
- Plasterers' Hodcarriers, Bricklayers' Hodcarriers, Roofers' Laborers, and Engineers, Portable and Hoisting, shall start 15 minutes before other workmen, both at morning and at noon.
- Five days, consisting of not more than eight hours a day, on Monday to Friday inclusive, shall constitute a week's work.
- Transportation costs in excess of twenty-five cents each way shall be paid by the contractor.
- Overtime shall be paid as follows: For the first four hours after the first eight hours, time and one-half. All time thereafter shall be paid double time. Saturdays (except Laborers), Sundays and holidays, from 12 midnight of the preceding day, shall be paid double time.
- On Saturday, Laborers shall be paid straight time for an eight-hour day.
- Where two shifts are worked in any twenty-four hours, shift time shall be straight time. Where three shifts are worked, eight hour's pay shall be paid for seven hours on the second and third shifts, allowing one-half hour for lunch.
- All work, except as noted in paragraph 9, shall be performed between the hours of 8 a.m. and 5 p.m.
- In emergencies, or where premises cannot be vacated until the close of business, men then reporting for work shall work at straight time. Any work performed on such jobs after midnight shall be paid time and one-half up to four hours of overtime and double time thereafter, provided, that if a new crew is employed on Saturdays, Sundays or holidays, which has not worked during the five preceding days, such crew shall be paid time and one-half.
- Recognized holidays to be: New Year's Day, Decoration Day, Fourth of July, Labor Day, Admission Day, Thanksgiving Day, Christmas Day.
- Men ordered to report for work for whom employment is provided, shall be entitled to two hours pay.

MODERNIZED PRODUCTS

Brief Notes on New Materials and Equipment in the Building Industry.

1. MAGAZINE

Westinghouse has issued a new member of their "magazine." It contains a great deal of interesting material and is very well arranged. Clip the coupon and send for your copy.

2. METAL TRIM

"Snap On"—a metal trim of distinction, is the new product of the Ramrod Metals Company, announced in a very smart brochure just off the press. By sending in the coupon you can have a copy.

3. LIGHTING EQUIPMENT

The Curtis Lighting Company have just issued a new booklet "Recessed Lighting Equipment." It details their new products—the latest in modern lighting, and contains some very interesting views of recent installations.

4. MAPLE FLOORING

A new type of hard maple flooring, iron bound edge-grain continuous strip, is announced by the Robbins Flooring Company. Their broadside giving the particulars of this new flooring is well worth having. Send for your copy.

5. CONCRETE

The Portland Cement Association has just put out a new bulletin giving the latest news on concrete; illustrated and diagramed, this bulletin contains excellent information on uses of concrete.

6. LIGHTING FIXTURES

A brand new catalog by Pittsburgh Reflector Company will prove highly interesting and has illustrated every imaginable type of lighting fixture. The coupon will bring you a copy for your information and for filing.

7. FURNACE & HEATER

The Superbo Manufacturing Company has issued two interesting little booklets on their furnaces and water

heaters for homes. These should prove valuable.

54. WESTERN PINE

One of the handsomest booklets of the month has been issued by the Western Pine Association, called "Western Pine Camera Views."

55. PAINTS & VARNISH

Dutch Boy Painter Magazine for May contains a fund of information about paints and varnish. Published by National Lead Co.

56. HOME LIGHTING

"Light in The Home" is the title of a new booklet just put out by The Pacific Coast Electrical Bureau, it is nicely arranged and has much useful information.

57. HEAT DIFFUSERS

The Carrier Corporation's new catalogue detailing their "Heat Diffusers" and other heating data is just received. Statistical data is given considerable space and is well arranged.

58. COPPER ALLOYS

The Copper and Brass Research Association's latest bulletin is extremely well gotten up and the illustrations are clear cut and interesting. There is considerable data on rustproof protection and copper alloys.

59. PLYWOOD

A brand new catalogue is just off the press—the Plywood Catalogue, issued by The United States Plywood Corporation. The coupon will bring your copy in an early mail.

60. LIGHT

The Pacific Coast Electrical Bureau has another booklet, very interesting and very well gotten up. It has for a title "Light Through the Ages" and details in short sketches lighting as it has progressed through the centuries.

61. TERMITES PROTECTION

E. I. Dupont de Nemours Company have issued a very fine booklet on Termites and Rot and have called their booklet one dealing with the so-called Building Bogies. Send the coupon for your copy.

62. KITCHEN CABINET SINKS

Three new kitchen cabinet sinks are the subject of a new, two-color folder issued by Crane Co., 836 South Michigan Avenue, Chicago, Ill. The sinks—the Kitchen Queen, Kitchen Pride and Homemaker, representing three different sizes and designs—are described and illustrated in detail. Card will bring the folder.

FREE FOR THE ASKING

Check items on coupon, paste on letter head or postal card, and mail to Architect and Engineer.

Architect and Engineer
68 Post Street
San Francisco, Calif.

Please send me literature on the following items as checked below. This request places me under no obligation.

- | | |
|-----------------------------|-----------------------------|
| 47 <input type="checkbox"/> | 55 <input type="checkbox"/> |
| 48 <input type="checkbox"/> | 56 <input type="checkbox"/> |
| 49 <input type="checkbox"/> | 57 <input type="checkbox"/> |
| 50 <input type="checkbox"/> | 58 <input type="checkbox"/> |
| 51 <input type="checkbox"/> | 59 <input type="checkbox"/> |
| 52 <input type="checkbox"/> | 60 <input type="checkbox"/> |
| 53 <input type="checkbox"/> | 61 <input type="checkbox"/> |
| 54 <input type="checkbox"/> | 62 <input type="checkbox"/> |

My Name

Name of Company

Street

City State

AVERAGE MONTHLY OUTLAY OF OWNING HOME

AMERICAN small town home owners spend for taxes, repairs, upkeep, insurance, and interest on mortgages about two-thirds as much, on the average, as the rents paid by families at the same income level. Depreciation and interest on invested capital were not included in the cash outlay of home owners.

The figures are from more than 9,000 families in 140 cities representative of the country as a whole, for a 12-month period in 1935-36. The survey was made by the Bureau of Home Economics of the U. S. Department of Agriculture in its Nation-wide family-living study.

The difference between the cash outlay of owners and renters varied considerably for families at different income levels and in different sections of the country. The section where the home owners' outlays were smaller was the Pacific region where the average ranged from \$4 to \$13 per family per month in the income brackets below \$4000. This amounted to about 50 per cent of the average expense for rented homes, which averaged \$9 to \$23 per family per month.

"These figures show that the outlay of home owners was less than that of the renters on housing during the year," says Dr. Louise Stanley, Chief of the Bureau of Home Economics. "However, in addition to the cash outlay, the home owners' interest on his investment and the depreciation on his house should be considered in any financial comparison. Then, too, a detailed study of the relative quality of the housing enjoyed by the owners and renters should be made and the satisfactions of ownership should be considered by the family trying to make a decision as to home purchase."

In New England, the owners' expenses for their homes ran close to those of renters. In two of the income brackets, the expenditures of the owners exceeded those of the renters. Average expense for owners was \$14 per family per month at the lowest income level (\$500-\$749) and \$29 in the highest analyzed in that region (\$3000-\$3999); for the renters, these averages were \$13 and \$27. In no case did the monthly expenditures of the renters average more than \$7 in excess of those of the owners. Included in the renter's outlay was whatever home repairs he made out of his own pocket as well as his rent.

In the North Central and Middle Atlantic region, home owners paid an average of \$5 to \$17 per family per month for upkeep, taxes, interest, and insurance. Rental expenses for the same income classes ranged in average from \$9 to \$23.

In the Mountain and Plains region average rental expenses ranged from \$4 to \$12 a month more than the average cost of repairs, upkeep, taxes, interest, and insurance on owned home. The average monthly expense for owned homes ranged from \$3 per family in the lowest income bracket to \$18 in one of the higher brackets. Average expense on rented homes ran from \$9 in the lowest income bracket to \$28 in the highest.

In the Southeast, the study of white families showed home owners' expenses to be higher than in any other region except New England. The renters' expenses, however, were lower than in any other section analyzed. In one income bracket (\$500 to \$749), expenditures for owned homes averaged \$1 more per family per month than those of rented homes, \$8 as to \$7; in another (\$4000-\$4999), the owned homes exceeded the rented homes in cost by an average of \$2 per family per month, \$25 as against \$23. In none of the income brackets were the home costs of renters more than an average of \$8 per month in excess of the costs of owners.

In a special negro study in the Southeast it was shown that on the whole the negroes who owned their homes were gainers thereby. The average cost of the owned homes ranged from \$2 per family per month for the income bracket \$250 to \$500, to \$5 per family per month for income between \$750 and \$1500. The average cost of renting a home ranged from \$3 per family per month for incomes under \$250 to \$7 for the incomes between \$1000 and \$1250. The negro families reporting incomes above \$1500 were so few that their expenditures were not analyzed.

Only nonrelief families containing both husband and wife, born in this country, were included in this Study of Consumer Purchases, conducted by the Bureau of Home Economics of the U. S. Department of Agriculture as a Works Progress Administration project, in cooperation with the Bureau of Labor Statistics of the U. S. Department of Labor, the National Resources Committee, and the Central Statistical Board.

ALADDIN HEATING CORPORATION EXPANDS

Increased business, the addition of several new lines and consequent demand for more shop room and storage facilities, were factors in determining a policy of expansion just inaugurated by Aladdin Heating Corporation. The company has moved from 5107 Broadway, Oakland, to 22d and San Pablo Avenue where it has one of the largest and best equipped sheet metal shops in the San Francisco area, together with attractive display windows, facing the Avenue, an enlarged sales department, executive offices and drafting room.

A more central location could not have been found and Manager Sam Terry feels that the latest move of his company is sure to result in increased business, and improved service. Architects in San Francisco, as well as in the East Bay, like to do business with the Aladdin Company because of the splendid service it gives regardless of the size of a contract. The new quarters are about two and one-half times larger than the old plant. The shop is electrically equipped.

Besides a complete line of Aladdin gas and floor furnaces and Aladdin air conditioning equipment, the company is agent for the Delco heating systems, Ruud hot water heaters and Kelvinator electric refrigerators.

BUILDING CODE REQUIREMENTS

SMOKE and panic as well as fire should be taken into consideration in framing building code requirements to prevent hazard to life, according to D. Knickerbocker Boyd, Fellow of the American Institute of Architects, who, in a survey of municipal building codes, has found many "costly, cumbersome, and unnecessary restrictions."

"Smoke and panic can be worse destroyers of human life than fire," Mr. Boyd points out. "Provisions against such hazards are assurances of safety which should be better understood."

Technical guidance exists which enables municipal officials responsible for building codes to take advantage of a vast field of accumulated data and to effect justifiable economies in construction and design requirements pertinent to the fire problem, Mr. Boyd asserts. The "fear" psychology which has come in waves coincident with disastrous loss of life in buildings should be discarded in favor of intelligent code-writing, he holds.

"It is in many places almost impossible to build modest homes of the fire-proof apartment type at low cost because of the unnecessary provisions for extra stairways which are required to be of the same number as in combustible types for certain story heights," Mr. Boyd says.

"People do not necessarily have to descend to the street level and get outdoors in case of fire if adequate provision is made for occupants of buildings to go horizontally into other portions of non-combustible buildings or to the roof and from one roof to another. Some cities, recognizing these factors, allow apartment houses, office buildings, and similar structures of fire-proof construction to be built without excessive exit requirements.

"It should be axiomatic that with sound construction and adequate safety provisions, costly and space consuming down and out exits should be decreased in number rather than become an added penalty upon those willing to build well. Codes should give latitude in favor of a well-planned building as against one merely complying with the letter of the law."

The "duration value" of a building in case of fire can be computed as a result of tests made by the American Society for Testing Materials, the National Bureau of Standards, the U. S. Bureau of Mines, and the American Society of Civil Engineers in collaboration with the National Board of Fire Underwriters and the Associated Factory Mutuals Companies, Mr. Boyd explains.

"The 'standard' fire by definition starts as an incipient blaze and rises in force, intensity, and temperature for a period of one hour to 1,700 degrees Fahrenheit of heat, and continues gradually to a temperature of 2,000 degrees at the end of four hours, by which time it resembles an inferno. The fire test has been applied to all kinds of columns used in building construction and to

walls and partitions. Machines of great power simulated the load of a building afire. In other experiments, powerful machines crushed every sort of wall and floor.

"Out of all these endeavors have emerged tabulated results for the use of all code framers. It is now possible, in properly prepared codes, through appropriate selection by some one expertly familiar with the 'duration' values, to require the various component parts of a building to be capable of resisting the devastating effects of fire, water, and falling structural members for a definite period of time.

"Thus, certain columns, walls, and stair enclosures may be required to have a four-hour duration, or three hours or two hours, while partitions, exits, floors and other structural features have a similar or less duration. It is of course inadvisable to have a four-hour wall with a fifteen-minute window. By proper adjustment of duration values, composite buildings can also be provided to accommodate several different kinds of occupancies."

Users of local codes should be made aware of mandatory requirements in state laws with regard to fire and panic, health and sanitation, storage and use of inflammable liquids, explosives, motion picture booths, and similar safety measures, Mr. Boyd continues.

"Code authorities should also realize," he adds, "that responsible national authorities have thoroughly standardized a great many materials and assemblies. Why should code framers, for instance, attempt to go into the details of elevator requirements when this work has been done fully and well by elevator authorities in collaboration with technical and trade organizations acting together under the sponsorship and final approval of the American Standards Association? Such requirements can be included merely by appropriate reference."

Mr. Boyd is not in favor of abbreviated building codes, even for small municipalities, because of the difficulty of finding properly qualified and disinterested persons to administer short codes. "Codes should be long enough to express properly all requirements and to eliminate all possible ambiguities," he declares. "The use of a long document is a comparatively simple matter when the contents are fully indexed and cross-indexed.

"The work of the building inspector would be far easier and building much more economical, if all codes in states which require architects and engineers to be licensed would also provide that permits to build be issued only upon drawings and specifications for which full responsibility of authorship is assured by a person legally practicing in the state.

A disinterested board of authority composed of a small number of architects, engineers, and other technically experienced men to whom the chief of the

building bureau may refer all special matters concerning code interpretation should be created by each building code. Mr. Boyd advises.

"Such a board can pass upon new materials and assemblies, the use of which cannot be foreseen when codes are drafted. It can oversee plans of properly designed exits and other matters of public safety, and coordinate the work of the various municipal officials in charge of zoning, sanitation, fire regulations, and other similar fields of action."

Modern codes, according to Mr. Boyd, require "certificates of occupancy," guaranteeing use of a building in accordance with its design. "All-purpose" buildings, constructed strongly enough to carry materials such as metals, paper, machinery, hides, or other heavy loads whether or not ever to be used in such a way, are things of the past, he says.

"Each building may now be constructed to carry only one of three loads—light, medium, or heavy—with a consequent saving of costs where the lighter types are ample. The certificate of occupancy, renewable with each change, is a necessary safeguard against improper use and overloading in the interest of the public as well as the individual owner."

WINNERS OF COLLEGE COMPETITION

Two young draughtsmen in New York offices won the most important architectural competition held in America during the last fifteen years. Richard M. Bennett, a draughtsman in the office of Edward Stone, architect of New York, and Caleb Hornbostel, son of the famous architect, Henry Hornbostel, have received the commission for the half-million-dollar art center to be erected at Wheaton College, Norton, Mass. Two hundred fifty-three unsigned designs were submitted by 243 individuals and firms throughout the United States. One California entrant, Richard J. Neutra of San Francisco and Los Angeles, received honorable mention.

EUREKA THEATER

A contract has been awarded to Moore & Roberts, 693 Mission Street, San Francisco, for the construction of a reinforced concrete theater and store building, Eureka, for Eureka Theaters, Incorporated. Contract price is \$124,986. Plans were prepared by R. C. Younger, 25 Taylor Street, San Francisco.

SMALL HOUSE COMPETITION

A national small house competition open to all architects and draftsmen, with nineteen prizes totaling \$7,500, has been announced by the Ladies' Home Journal.

In framing the details of the competition, the Journal has worked closely with the Federal Housing Administration, and with its national advisory committee, consisting of Mrs. Franklin D. Roosevelt, chairman; Gen. Hugh S. Johnson, and Stewart McDonald, Federal Housing Administrator.

The theme of the competition is, broadly, the judicious enclosure of the greatest amount of useably convenient living area within the cubage limitations for the least amount of money.

The competition closes midnight, July 18th, 1938 and the schedule of prizes includes a grand first prize of \$1,500; prizes for the next best five designs of \$1,000 each; seventh prize \$250; eighth, ninth and tenth prizes at \$100; and nine honorable mentions of \$50 each.

J. B. STRAUSS—BRIDGE BUILDER

Joseph Baermann Strauss, 68, chief engineer during construction of the Golden Gate Bridge, passed away in Los Angeles May 16th following a brief illness.

In Southern California for his health, Mr. Strauss was not considered seriously ill until stricken with coronary thrombosis March 28. He had been bedridden since.

Retired from active work since completion of the Golden Gate Bridge exactly a year ago Mr. Strauss had sought rest and an escape from the financial, political and personal tribulations endured before and during the bridge construction.

During his lifetime Mr. Strauss was chief engineer or consultant in the construction of 500 major bridges in the United States, Canada and European countries. The \$35,000,000 span across the Golden Gate was his last and most dramatic achievement.

Mr. Strauss was born in Cincinnati. He was graduated from the University of Cincinnati in 1892, later served the school as an instructor in the engineering department.

His first job was as draftsman for the New Jersey Steel and Iron Company, Trenton, N. J. He acted as designer for the sanitary district of Chicago and then founded the Strauss Engineering Corporation of Chicago and San Francisco.

He designed the Republican bridge at Petrograd, Russia; the Longview, Wash., bridge across the Columbia River; the bascule span of the famous Arlington Memorial bridge at Washington, D.C., and others of equal note.

Mr. Strauss held the capacity of consulting engineer to the Port of New York Authority, and a half dozen foreign governments.

A poet and dreamer, as well as a great engineer, Strauss, barely five feet tall, was termed by his associates, "the little man with the big dreams."

His poetry won recognition when three pieces, "The Redwoods," "Yosemite," and the "Bridge of Ages" were selected for California's contributions to a 1934 anthology.

Mr. Strauss was the originator of five types of the Strauss trunnion bascule bridge, standard throughout the world, and originated two types of lift bridges. A

type of portable searchlight he invented was used by the United States and Russian governments during the World War.

Mr. Strauss' first big job was the designing of a railroad bascule bridge in Cleveland. Concrete instead of steel was used for counterweights. The new bridge worked perfectly and provided the key for his success.

Although the main office of Strauss & Paine is in Chicago, Strauss spent most of the past nine years in San Francisco, helped to organize support for authorization of the bridge's construction, then saw to its building and the realization of his greatest dream.

ELECTRICALLY MODERN HOMES

Good wiring pays higher dividends than any other factor of expense in a home, according to a recent survey.

Fifty years ago, people thought food cooked by electricity was poison. Now, mixers, toasters, griddles and grills are as familiar as pots and pans in the modern kitchen. Electricity does everything from cooking a meal to giving a sun bath. And there is no reason why the next fifty years will not witness an even greater advance in its use.

In the first place, electricity is cheaper than ever. Since 1920, the average cost of a kilowatt hour has dropped from 7½ to 4 1/3 cents. Six and one-half cents winds the clock, \$1.05 sweeps the carpet, \$4.38 furnishes entertainment and \$4.81 does the washing and ironing, for an entire year.

In the second place, appliances cost less and offer more service. You may be surprised to know that twenty-eight million radios and eleven million electric refrigerators have been sold in less than ten years. Over night, the sales of water-heaters, room-coolers, electric roasters and razors have doubled. Electricity is the cheapest way of offsetting other higher costs.

The Wall Street Journal estimates that 300,000,000 more appliances—floor polishers, ranges, refrigerators, clocks—worth \$18,000,000,000 will be bought before the saturation point is reached.

Therefore, it is most imperative that wiring systems carry their intended load, without failure. And it is economically desirable that they permit expansion for additional loads as needs arise.

LOW COST HOUSING IN PORTLAND

Medium cost residences are being built in goodly number on acreage tracts in the vicinity of Portland while the construction of new dwellings in the city itself has decreased. A steady demand is found for suburban properties and numerous sales are being made in small acreage tracts. Seventy-three tracts have been sold this year in the Kilpatrick Addition on Palatine Hill Road, where some twenty new houses have been completed or are in the course of construction.

COPPER SENSE

With his keen appreciation for the beauty and charm of fine art objects, the architect might easily prefer an antique copper lamp with its rich patina, to a few miles of copper wire hidden in the walls of his building.

But today the architect cannot choose beauty alone. Another demand is made. Beauty, yes—but the first requirement is utility.

Instead of being used to form a lamp, copper today is drawn into wires to carry the energy for light—and power too.

Scores of services depend upon the copper wires hidden in the walls of buildings. Here people are not looking for beauty in their copper. In a wiring system, they want just one thing—electric service when and where they need it.

Today buildings that fail to provide adequate electrical service are not revered as antiques—they are condemned for obsolescence.

Be sure your buildings provide for the increasing use of electric service.

PACIFIC COAST ELECTRICAL BUREAU

447 Sutter Street

601 W. 5th Street

SAN FRANCISCO • CALIFORNIA • LOS ANGELES

*Modern Homes are
Air-Conditioned by*

SELECTAIR

● DESIGNED and built by the S. T. Johnson Co., pioneer manufacturers of Oil Burners, this smart new air-conditioner combines in one compact unit every feature desired by home-owners, architects and engineers for economical heating, air-conditioning and ventilating the modern home. Year-round hot water. Forced air circulation for summer. Equipped with the popular BANKHEAT Pressure-Type Burner. Furnished in enamel with chrome trim.

Send for "Selectair" Bulletin & complete specifications

S. T. JOHNSON CO.

Oil Burners

940 Arlington Avenue, Oakland, California
401 Broad Street, Philadelphia, Pa.

● THERE'S A JOHNSON OIL BURNER FOR EVERY PURPOSE

"Goods of the Woods"

Dependable Building Materials

Lumber and Millwork
for
All Types of Construction

★

**Wolmanized or Creosoted
Lumber and Timbers
is your protection against
Termites and Decay**

★

E. K. WOOD LUMBER CO.

San Francisco

Los Angeles

Oakland

SAFE PLUMBING

How can plumbing be made 100 per cent safe?

What must be done to prevent the contamination of the drinking water in a building by water of doubtful purity?

In order to find the correct and scientific answers to these important questions, the plumbing industry two years ago asked the Institute of Hydraulic Research at the State University of Iowa to undertake a comprehensive research program.

In a recently published booklet entitled "Cross-Connections and Back-Siphonage Research" appears a report on the research work which members of the plumbing industry believe is of interest to everyone who is concerned with buying plumbing, writing specifications for plumbing, or installing plumbing.

Six specific recommendations for water connections to air conditioning equipment are made in the report, one of which reads as follows: "All water and waste connections to air-conditioning equipment should be made by skilled and licensed men who understand the health hazards of cross-connections and back-siphonage."

Included in the chapter on "Proper Design of Water-Supply Piping in Plumbing Systems" is much new and significant information on the correct sizing of piping for the prevention of excessive friction losses.

"Most of the vacuums that occur in water pipes," says the report, "are caused by improper pipe sizing and by the use of fittings and valves which introduce excessive friction loss. At least 90 per cent of all vacuum formations, and therefore 90 per cent of the hazards of back-siphonage could be prevented if water-piping were sized and installed correctly."

After suggesting certain regulations regarding pipe sizing, rates of flow to fixtures, and location of water pipes, the report concludes with the following statement:

"No amount of regulation will ever insure proper water-piping design and installation of all the great variety of water-piping systems. To a great extent dependence for proper installation must be placed on the designer and contractor.

"It is, therefore, imperative that all water piping to all the individual fixtures and units of equipment shall be installed by persons who possess, and who are required to possess by law, a knowledge of flow of fluids and of the action of back-siphonage, and an understanding of the dangers of bacterial infection of the water supply.

"The proper and correct installation of no other part of the plumbing system is so important to the preservation of public health as is that of the water-supply piping."

Copies of the report may be obtained from the National Association of Master Plumbers, Edmonds Building, Washington, D. C.

MAKE THAT ROOM SEEM EITHER

Higher or Wider

Set *vertical*, Master Kraftile units seem to increase the height from floor to ceiling.

Set *horizontal* . . . these six by nines add *width* to a room.

And their architecturally correct shapes . . . width in ideal proportion to length . . . make possible modern wall treatments strikingly different in design. Yet these Kraftile six by nines cost no more installed than conventional 4 1/4" tile.

Write for a beautifully illustrated folder that shows unusual room treatments with Master Kraftile as created by California architects. Address: Kraftile Company, Niles, California.

See your Sweet's: Catalog 5, Section 11

NEW 6 x 9

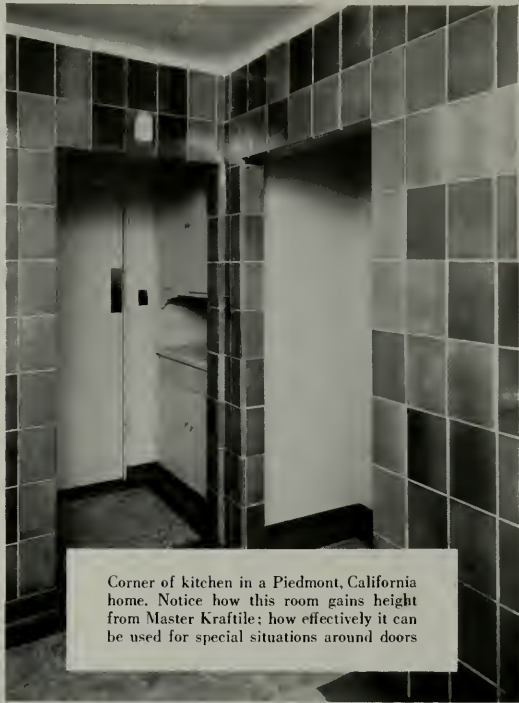

Corner of kitchen in a Piedmont, California home. Notice how this room gains height from Master Kraftile: how effectively it can be used for special situations around doors

*Protect the Beauty
you Create!*



SPECIFY

DUTCH BOY

PAINTER PRODUCTS

Your client will recognize your quality choice . . . your contracting painter will be glad to use Dutch Boy products. . . . They are long-lived and economical in use. Your National Lead Company Specification Book gives you correct information for specific uses. . . . Or, if you need further technical advice—

ASK THE NATIONAL LEAD MAN

National Lead Company branches in all principal cities

ALADDIN OFFERS—

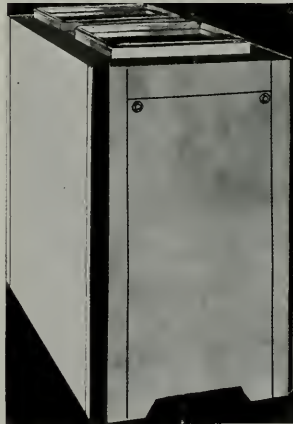

The new gas-fired winter air conditioning unit.

It automatically heats, humidifies, filters and circulates healthful air throughout the house.

**Low in purchase price
Low in operating costs**

Let us solve your heating problem

ALADDIN HEATING CORPORATION
2222 SAN PABLO AVENUE • OAKLAND

**Pressure
Treated Lumber?
Specify**

BAXCO CZC

**"Chromated Zinc
Chloride"**

**Protects against decay
and termite attack**

•
*Available for prompt shipment
throughout California*

•
J. H. BAXTER & CO.

601 W. 5th Street
LOS ANGELES
Phone Michigan 6294

333 Montgomery Street
SAN FRANCISCO
Phone DOUGLAS 3883

CRACKING OF CONCRETE BY ALUMINIUM

An enquirer reported an interesting case of extensive fracture of concrete posts in which were embedded aluminium plates carrying traffic reflectors. Photographs of a number of posts were submitted and these showed consistently cracking of the form. An explanation of the cracking was requested:—

Reply

Aluminium combines readily with free lime to form calcium aluminates and hydrogen gas, a reaction which results in gross expansion. As free lime is liberated when cement sets, corrosion of aluminium embedded in concrete is inevitable under moist conditions and the consequent expansion will result in the fracture of the set concrete. The form of failure shown in the photographs indicates that general expansion has occurred, and there seems little doubt that the formation of calcium aluminate was the cause of the failure.

Aluminium, zinc and galvanized iron cannot safely be embedded in concrete unless completely protected by an application of bituminous paint or other suitable material, and in the present case this precaution must be adopted or some other metal employed.

It is of interest in this connection to note that aluminium powder is used as an active agent in the manufacture of so-called gas-concrete—a light weight concrete. A proportion of the metal powder is added to the wet mix and the hydrogen evolved causes an increase in volume. In the manufacture of lightweight concrete the proportion of aluminium powder is so adjusted as to yield an expansion of about 100 per cent.

—Building.

FREE REIN For Your Architectural Motif



**When You Specify
STANLEY
"ROLL-UP"
DOORS**

•
No mechanical problems of door construction or operation will interfere with your architectural plan if you use Stanley "Roll-Up" Door Hardware. Applied to either stock doors or individual designs, the same carefree service is assured.

From the standard private garage opening to the largest commercial door—Stanley "Roll-Up" Doors offer the best solution. Ball bearing rollers in perfectly aligned steel tracks. Heavy springs counterbalance the door in any position. Requires little headroom. Descriptive literature on request. The Stanley Works, New Britain, Conn. Los Angeles: 407 American Bank Bldg.; San Francisco: 576 Monadnock Bldg.; Seattle: 568 First Ave., South.

**MADE TO FIT
ANY SIZE
OPENING**

**STANLEY HARDWARE
FOR *Carefree* DOORS**

BUYS SANTA BARBARA HOTEL

Frank J. McCoy, owner and manager of Santa Maria Inn, located on the highway about 90 miles north of Santa Barbara, has purchased the entire property of the beautiful El Encanto hotel property, Santa Barbara, where the State architects held their annual meeting last year. El Encanto is located on the so-called Riviera, Santa Barbara, commanding a wonderful view of the city and environs. Charles C. Hervey now has a lease on El Encanto which expires in October. Mr. McCoy will then take possession. In the meantime, Mr. McCoy is vacationing in Honolulu. Mr. McCoy is famous as having operated the Inn at Santa Maria for many years, and in the Santa Maria Daily Times recently appeared a special editorial devoted to Mr. McCoy and praising his splendid citizenry and commenting on his high standing in his community.

Fernand Pimentel, resident manager of the Santa Maria Inn for many years, will be manager of the El Encanto, and George A. Thompson, of Southern California and Arizona hotel experience, becomes resident manager of the Inn.

BOOK REVIEWS

PLAN YOUR HOUSE TO SUIT YOURSELF: By Tyler Stewart Rogers; Charles Scribners Sons Co., New York City, N. Y. Price: \$3.50.

Here, in a very convenient form, is summarized the base fundamentals of construction. The book is written by a member, in fact by the head of one of the leading architectural firms of Chicago. It has been prepared as an up-to-the-minute handbook for the person who is to do that very important piece of work in the building of a home—supervision.

There are over twenty chapters, all well arranged and containing a wealth of valuable and useable information.

* * *

AIR CONDITIONING—FURNACES AND HEATERS: By J. Ralph Dalzell; American Technical Society, Drexel Avenue, at 58 Street, Chicago, Ill. Price: \$3.00.

An excellent book dealing with a subject of importance to all home and building owners, architects and contractors. Heating engineers will find here a worthwhile addition to their shelves. The book covers a wide field, is well illustrated.

* * *

LIGHT, PHOTOMETRY, AND ILLUMINATING ENGINEERING: By William Barrows; McGraw-Hill Book Co., 330 West 42nd Street, New York City, N. Y. Price: \$4.00.

A very fine, clear and well illustrated book dealing with an important subject in every day life. This book should be of especial value to the lighting engineer, who is keeping abreast of times; likewise the architect can find much of value and interest here and is serving the better interests of his clients when his working library contains such books for ready reference.

BUILDING MATERIALS ANNOUNCEMENT

Golden Gate-Atlas Materials Co., San Francisco, and Transit Concrete, Ltd. in the East Bay Area (subsidiaries of Pacific Coast Aggregates, Inc.) announce the following personnel changes, effective May 5:

Transit Concrete, Ltd.—Chas. M. Cadman, president; Carroll Stephens, vice-president and general manager; Orlo P. Steele, assistant to general manager; H. W. Senter, secretary and treasurer; W. S. Betts, assistant secretary and assistant treasurer; A. R. Davies, sales supervisor; David M. Graham, sales representative; H. MacManaman, sales representative; A. L. Coady, sales representative.

Golden Gate-Atlas Materials Co.—Chas. M. Cadman, president; Carroll Stephens, vice-president and general manager; Orlo P. Steele, assistant to general manager; H. W. Senter, secretary and treasurer; Maurice W. Griffin, assistant secretary; Frank W. Harrison, sales representative; Stanley L. Crawford, sales representative; J. E. McClintock, sales representative; Robert C. Ford, and Robert T. Morris, Jr., specialty sales.

No Worry for the Architect

—All acid proof drain pipe and fittings shall be ferrosilicon—CORROSIRON—

The architect who writes this in his specifications solves at once his problem of overcoming corrosion.

[Write for this specification]



FEDERAL BUILDING • CIVIC CENTER • SAN FRANCISCO

Arthur Brown, Jr., Architect

CORROSIRON DRAIN LINES and FITTINGS and LABORATORY EQUIPMENT was specified because of its superior resistance to corrosion and wear.

Pacific Foundry Company, Ltd.

NEW YORK • 3100 NINETEENTH ST., SAN FRANCISCO • LOS ANGELES

BUILD WELL~

A PROPERLY designed and well constructed building is a credit to any city and a profitable investment for its owner.

Such structures are the STANDARD OIL BUILDING, MATSON BUILDING, FOUR-FIFTY SUTTER STREET, STOCK EXCHANGE, S. F. BASE BALL PARK, MILLS TOWER, OPERA HOUSE and VETERANS' MEMORIAL, San Francisco, OLYMPIC CLUB ALTERATIONS, SANTA ANITA RACING PLANT and other notable structures—all built or supervised by—

Lindgren & Swinerton, Inc.

Standard Oil Building
San Francisco

605 W. Tenth Street
Los Angeles

We Maintain a Termite Control Department



"Color - Pulls"

Durable Plastic - Ultra Modern
Wide variety of Color Combinations
Drawer Pulls - Knobs - Towel Racks



Literature on Request

HOLLEY MANUFACTURING COMPANY
912 S. E. MAWTHORNE BOULEVARD PORTLAND, OREGON



*S*PECIAL lighting equipment for distinguished residences is no longer required. Now Lightoliers, in all periods, for all locations, styled and constructed from expensive "specials" are available at low cost — through dealers or at our showrooms. Send for "The Charm of a Well Lighted Home", an informative manual on correct residential lighting.

INCANDESCENT SUPPLY CO.
SAN FRANCISCO : OAKLAND : FRESNO : LOS ANGELES

The better homes of today are
AIR CONDITIONED
for year-round weather

Consult us for the answer to your problems



MANUFACTURERS
of
OIL FIRED FURNACES
GAS FIRED FURNACES
SHEET METAL PRODUCTS

Harer-Perry Company

5662 Keith Ave., Oakland, Cal.
Phone HUmboldt 7928

A Permanent Exposition
of the newest ideas
in home planning
and equipment.



THE BUILDING MATERIAL EXHIBIT

Architects Bldg. • Fifth & Figueroa • Los Angeles • MU-6306

INCLUDE TREES IN YOUR PLANS

DAVEY, ORIGINATOR OF TREE SURGERY, OFFERS FREE
INSPECTION AND ESTIMATE.



SAN FRANCISCO Fresno LOS ANGELES
Russ Bldg. Mattei Bldg. Story Bldg.
SUtter 3377 TUCKER 1929
Local phones in: Pasadena, Palo Alto,
Oakland, San Rafael, San Mateo

SKILL - KNOWLEDGE - RESPONSIBILITY

STRUCTURAL STEEL

For Class A Buildings,
Bridges, etc.

JUDSON PACIFIC CO.

609 MISSION STREET
SAN FRANCISCO

Plants: San Francisco - Oakland

USE BASALITE

Light-weight, pre-fabricated Con-
crete building products for floors,
walls, and roofs in your next
building.

BASALT ROCK COMPANY, INC.

Napa, California

NOISE Control

Office Quieting
Sound-proof Partitions
Acoustical Correction

WESTERN ASBESTOS CO.

Building Materials *Mechanical Specialties*
SACRAMENTO OAKLAND
SAN FRANCISCO

MULLEN MFG. COMPANY

BANK, STORE AND OFFICE
FIXTURES—CABINET WORK
OF GUARANTEED QUALITY
CHURCH SEATING

Office and Factory:
60-80 RAUSCH ST., Bet. 7th and 8th Sts.
San Francisco
Telephone UNDERhill 5815

OVER NIGHT OR JUST A MEAL



SANTA MARIA INN

FRANK J. MCCOY, Manager

On the Coast Highway, midway between
San Francisco and Los Angeles

Phone GARfield 1164

Hunter & Hudson

Consulting Engineers

DESIGNERS OF HEATING
AIR CONDITIONING
VENTILATING AND WIRING
SYSTEMS, MECHANICAL
AND ELECTRICAL EQUIP-
MENT OF BUILDINGS



41 SUTTER STREET
ROOM 710

San Francisco California

G. P. W. JENSEN & SON

Building Construction

320 Market Street, San Francisco

Phone: GARfield 2444

REALTY BOOM IN THE MAKING

There is every indication of increased real estate activity, and those who have money to invest should forget the "calamity howlers," Col. Harold Lee, Deputy General Manager of the Home Owners' Loan Corporation, declared in a recent Washington interview.

If people don't purchase property in today's market, Col. Lee warned, they soon may find prices up, interest rates higher, and terms less favorable.

Assuring real estate men that they need have no fear of the Home Owners' Loan Corporation policy on sale of real estate, since it still was "mindful of the need for stabilization of the market," he added:

"Real estate today is in an unusually favorable position. We have never lived in a period when the vacancy ratio and interest rates have been so low, money so plentiful and terms so favorable to the buyer. The situation is most tempting from the buyer's point of view.

"The Metropolitan Life Insurance Company has announced that it plans to spend \$100,000,000 on rental housing in the next five years. The Prudential Insurance Company also is investing in low rent housing and it is not unlikely that other life insurance companies will follow suit. Federal Housing Administration has insured loans amounting to more than \$20,000,000 on large scale renting developments and many more projects are under consideration.

"The briskly increasing monthly sales of the Home Owners' Loan Corporation and evidence from every quarter definitely point toward increased real estate activity. Ordinarily such activity is reflected in higher prices, higher interest rates and more restrictive terms. Those who have money to invest should forget the calamity howlers. They should go ahead and purchase in today's market."

BETTER SCHOOL LIGHTING

The fact that 23 per cent of the U. S. citizens have poor eyesight before they reach 20, and 48 per cent before 40, as recorded by the Illuminating Engineering Society and Amer-

HOTEL L'AREMONT

20 Acres
of Park

Enjoy...

... all the benefits of a
country estate in town.

Tennis, riding, golf, dancing, quiet nights to insure sound sleep. Excellent meals at moderate family prices. Large outside rooms with bath \$2.00 and \$2.50. Ideal location overlooking Golden Gate, convenient to all Bay cities. Write today for descriptive booklet.

BERKELEY *California*

OFFICE FURNITURE
MODERATE PRICES
LIBERAL BUDGET TERMS

H. S. CROCKER COMPANY, Inc.

MARKET STREET AT SECOND
SAN FRANCISCO

Robert W. Hunt Company ENGINEERS

Inspection - Tests - Consultation
Schools and Other Structures
Are Built as Designed

*When Construction Materials are
Inspected at point of Manufacture
and during Erection by*

ROBERT W. HUNT COMPANY

*Cement, Concrete, Chemical, Metallurgical,
X-Ray and Physical Laboratories*

Chicago - New York - Pittsburgh
Los Angeles - All Large Cities
San Francisco, 251 Kearny Street



No longer a problem
for the Architect

TRANSIT MIX CONCRETE AND MORTAR

makes delivery of material to the job swift and inexpensive . . . minimizing the architect's supervision costs and assuring his client a dependable mix.

Speed . . . Reliability . . . Economy
Let us co-operate with you

Golden Gate-Atlas Materials Co.

16th and Harrison Streets
San Francisco
UNderhill 3650

Modern Design Dignified and Good Looking



Model No. 75

This new semi-recessed HAWS DRINKING FOUNTAIN is made of Vitreous China and answers a demand for an attractive, well built fixture for public and semi-public buildings.

HAWS DRINKING FAUCET CO.
1808 Harmon Street Berkeley, Calif.

ican Institute of Architects recently, indicates the need for better school-room lighting.

As an aid in improving this condition engineers have developed an unerring monitor of light, which silently and without outside attention automatically turns room lights on when artificial illumination is needed, and which likewise turns them off when natural light provides adequate lighting.

The device, similar in cost to a wall clock, is simple in operation. By two knobs on the face of the instrument, proper adjustment can be made, so that when the light intensity is not adequate for correct vision, artificial light is turned on. It is turned off again automatically when no longer required.

So that the control can be readily applied to existing rooms as well as in new buildings, two types of mounting have been developed. A surface-mounted equipment is used in an existing building where it is not expedient to cut into the walls. A flush-type equipment has been designed for installation in new buildings. The connection to existing light circuits is made at the wall switch.

Improper and inadequate light is a detriment, not only to eyes, but to the work of school children, as shown in a test study made in the Tuscomb, Ala., city school. Two adjoining rooms were used for the three-year test, and students of similar grade, as determined by the teachers by previous progress, were seated in the two rooms. The teachers alternated in the teaching tasks.

One room was equipped with two 150-watt, direct-type fixtures and in the other room were installed four 300-watt, totally indirect fixtures controlled by a photoelectric relay. This relay incorporated an "electric eye" and a switch for turning the lights on and off. It was mounted so that it measured the amount of natural light available. A time clock was also used to put the mechanism into operation at eight o'clock in the morning and to turn it off at three o'clock in the afternoon, on school days.

At the end of the first year, it was found that 21.1 per cent less failures

Donovan Automatic Awning Type Windows

Give 100% natural ventilation
and day-lighting control

•
**UNIVERSAL WINDOW
COMPANY**
Berkeley, California

"AMERICAN MARSH" Redi-Vac Vacuum Heating Pump

Send for
Bulletin 441

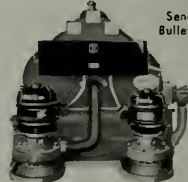

SIMONDS MACHINERY CO.
San Francisco Los Angeles
816 FOLSOM ST. 522 EAST 4TH ST.

SISALKRAFT

REG. U. S. PAT. OFF.

"More than a
building paper"

THE SISALKRAFT CO.
205 West Wacker Drive
(Canal Station) Chicago, Ill.
55 New Montgomery Street
San Francisco, Calif.

Pacific Manufacturing Company

High Class Interior Finish
Quality Millwork

154 Montgomery St. 6820 McKinley Ave.
San Francisco Los Angeles
GARfield 7755 THornwell 4196

1315 Seventh Street, Oakland
GLencourt 7850

Here's the last word IN BATHROOM HEATING



The WESIX "49er"!

Every new home should have one.
List price, only\$21.50
For catalog sheet and specifications

write to
1018 Wesix Building
San Francisco, California

WESIX

ELECTRIC HEATER CO.

occurred in the room which was photoelectrically controlled, while in the second year the percentage of failures in the normally lighted room was 19.1 per cent above that of the indirectly lighted room. In the third year of the test, 12 per cent fewer failures were noted in the room having automatically controlled lighting.

Automatic light control makes manual attention to lighting unnecessary. It eliminates guessing on the part of the teacher whose desk, incidentally, is usually nearer the window and hence better lighted than that of the child sitting back against the blackboard wall who may not be receiving enough light.

The controlled system of lighting provides for more even distribution of lighting at all times. As soon as the natural illumination falls below a predetermined level, the relay goes into action and more artificial light is produced. In turn, as the natural light intensity increases, the artificial illumination is turned off, without requiring the attention of teachers or janitors.

It was found in Wyandotte, Mich., schools that the cost of the equipment was less than that spent for clocks. The resulting power costs, following installation of the photoelectric control equipment, were in many cases lowered, since artificial illumination was not used when it was not needed. In this connection, it was found that in some schools the lights were turned on in the morning and left on all day, regardless of outside illumination.

HALF MILLION TUNNEL

The contract for the Shoo-fly Tunnel at Shasta dam site in the Sacramento River Canyon, north of Redding, California, has been awarded to the Colonial Construction Company, of Spokane, Washington, for \$426,475.

The tunnel will be driven through the west abutment at the dam site. Temporarily, it will be used to relocate the main line of the Southern Pacific Railroad, which passes through the dam site and through the reservoir area following the canyon. Relocation of the railroad through the tunnel will permit work to begin in the near future on Shasta dam, itself, the key engineering structure of the huge project.

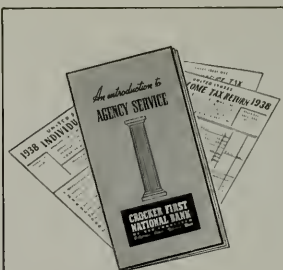

Less Work Next Year

If you have substantial holdings of securities, this booklet will interest you. It explains how our inexpensive Agency Service would be helpful to you, not only at income tax time, but throughout the year...by relieving you of all bothersome routine and time-wasting details.

You may have a copy, on request.

**CROCKER FIRST
NATIONAL BANK**
OF SAN FRANCISCO
California's Oldest National Bank



HERRICK IRON WORKS

STRUCTURAL STEEL

18TH AND CAMPBELL STS.
OAKLAND, CALIF.
Phone GLencaurt 1767

FORDERER Cornice Works

Manufacturers of

Hollow Metal Products
Interior Metal Trim
Elevator Fronts and Cabs
Metal Wall Plugs, Anchors, Etc.
Sheet Metal Products
Sanitary Metal Base
Commercial Refrigerators
Building Paper
Metal and Wire Accessories
for Concrete

269 POTRERO AVENUE
San Francisco, Calif.
HEmlock 4100
CONSULT OUR ENGINEERING
DEPARTMENT

PAN-AMERICAN

(Simplex)



Model 12

AUTOMATIC OIL BURNER

The model illustrated is the smallest of many sizes and types of oil burners built by

**PAN-AMERICAN
ENGINEERING CO.**

320 Parker Street • Berkeley
Phone BErkeley 6755

/N ONE-PIECE WATER CLOSET



The first and finest one-piece water closet. No elevated tank and not attached to wall. Can be installed in corners, under stairs or windows. Simplified fittings assuring positive, quiet performance. Special regulating stop, designed for either angle or straight supply, permitting volume regulation of water under all pressures. Sold only by Master Plumbers.

Distributed by

TAY HOLBROOK, INC.

SAN FRANCISCO

OAKLAND

SACRAMENTO

SAN JOSE

FRESNO

DINWIDDIE CONSTRUCTION COMPANY

BUILDERS OF
GOOD BUILDINGS

CROCKER BUILDING
SAN FRANCISCO

Carl T. Doell Co.

Plumbing
Heating

Plumbing Contractor
Veterans Memorial Building
Oakland

467 21ST STREET
OAKLAND

Telephone GLencourt 8246

ROOFING ODDITIES

The Egyptian peasants of today use the identical roofing material—sun-dried bricks—to fill the roofs of native houses, as their ancestors used in Biblical times.

* * *

Superstitious natives of Sicily paint huge snakes on the roofs of their houses as a protection against lightning.

* * *

In Central Nigeria, Africa, the natives place a lion's body on the roof of their hut over the entrance, so that roaming lions will be frightened away.

* * *

Hildestein Cathedral, in Germany, has the oldest copper roof in the world. It was put on in 1320.

* * *

It is stated that the Norwegian peasants paint the roofs of their houses a different color once a month, so that evil spirits will not recognize the house and haunt its occupants.

* * *

In Burmah the roof of a house in which someone dies is promptly destroyed and a new one built in its place to prevent the ghost from haunting the house.

* * *

During early times in Egypt it was customary for priests to hold church services on the roofs of various buildings in order to be nearer heaven.

* * *

When a Hindu suitor is accepted by a girl's father, he always kisses the roof of her home to show his respects.
—Building, Sydney, Australia.

KITCHENS AND HOMES

Kitchen-minded are citizens of Spokane as a result of Washington Water Power Co.'s and Spokane Better Housing Committee's concentration on the subject of all-electric kitchens, says a writer in "Electrical West." Activity which last year accounted for completion of plans for more than 450 kitchens is being continued this year on the same, though more closely supervised, scale.

Tying in with the National Kitchen Modernizing Bureau's activity, the utility in 1937 drew nearly 300 entries

COMFORT

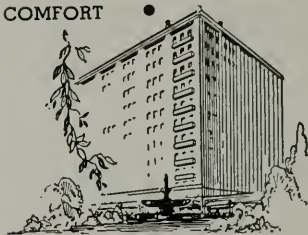

New HOTEL CLARK

in Downtown

LOS ANGELES

Convenience is another offering of this hotel. Whether on business or pleasure bent, the Hotel Clark makes an ideal "base of operations," as well as a restful "billet" at the end of the day's "campaign." Good Food, naturally. And moderate charges, as well as for room accommodations, give final significance to assuring word — COMFORT

Single from \$2.50

Double from \$3.50

Fifth and Hill

ROOMS
555
BATHS

P. G. B. MORRISS, Manager

Smith

Lumber Company

WHOLESALE - JOBBING - RETAIL

FACTORY AND BUILDING LUMBER

PLYWOODS - ROOFING

DISTRIBUTING YARDS

San Francisco

Oakland

4th & Channel

19th Ave. &

Market 0103

Estuary

FRuitvale 3174

YOUR INQUIRIES SOLICITED

JOSEPH MUSTO SONS-KEENAN COMPANY

MARBLE
and
ONYX

535 NORTH POINT STREET
SAN FRANCISCO
1801 S. SOTO STREET
LOS ANGELES

ABBOT A. HANKS, INC.
Engineers & Chemists

INSPECTING — TESTING — CONSULTING
CONCRETE • STEEL • MATERIALS
CHEMICAL AND TESTING
LABORATORIES
• RESEARCH AND INVESTIGATION •

TESTS OF STRUCTURAL MATERIALS
DESIGN OF CONCRETE MIXES
SHOP AND ERECTION INSPECTION OF
STRUCTURES AND EQUIPMENT
INVESTIGATION OF STRUCTURES
AND MATERIALS
TESTS AND INVESTIGATION OF
FOUNDATION SOILS
FIRE RESISTANCE AND INSULATION
TESTS

624 Sacramento Street, San Francisco

VAUGHN - G. E. WITT Co.

Manufacturers and Distributors

Pump Governors	Oil Heaters
Safety Pump Governors	Relief Valves
Automatic Gas Regulating Valves	Oil Burner Governors
Gas Burning Equipment	Oil Burners
Vacuum Pump Governors	Oil Pumping Sets
Vacuum Regulating Valves	Oil Valves
Continuous Flow Steam Traps	Oil and Steam Strainers
Thermostats	Duplex Oil Pumps
Reducing Valves	Rotary Oil Pumps
	Boiler Feed Pumps
	Water Heaters
	Boiler Feed-Water Regulators

4224-28 Hollis St., Emeryville, Oakland



MERCURY PRESS

We Print
*The ARCHITECT and
ENGINEER*

*"A Thing of Beauty
Is a Joy Forever"*

942 HOWARD STREET
SAN FRANCISCO

Copper Halftones
in this issue

Made by

**Continental Engraving
& Color Plate
Co.**

156 Second Street
San Francisco

from 3,000 kits distributed in the kitchen planning contest.

Meetings, at which the kitchen modernizing program was explained and illustrated, were held with both Spokane and suburban dealers. The story of the step-saving kitchen was told at several women's club sessions and at cooking schools. Ten new model kitchens were built in local stores and ten in the main suburban offices of the company.

An indication of how well the story was put across is a survey made toward the end of the year of 218 kitchens planned in Spokane. Of the 185 replies, 85 reported that they had completed the kitchen; 82 that they were in the process of completion; 22 that they did not intend to do any work. Eighty-four had installed new lighting and/or wiring; 24, ventilating fans; 43, ranges; 46, refrigerators. A high percentage had made other improvements such as painting, plastering and plumbing.

Budget for the 1938 effort is set at the same figure, \$8,000, as last year. Last year, however, the electrical industry carried only 29 per cent of the burden; this year it will carry over 33 per cent.

COLOR AND HEAT

Due largely to recent work in connection with the heat emission from radiators of various colors, an impression has been circulated that the painting of radiators different colors will affect the fuel consumption of a building. The basis for this reasoning is the finding that a black or dark radiator will emit more heat per square foot of surface than will a radiator painted a lighter color.

"This is a perfectly logical and true finding," says Allen J. Johnson, Director of the Anthracite Industries Laboratory at Primos, Pa., "but the fallacy of attempting to apply this to an interpretation of coal consumption is that if a room is adequately heated, the amount of heat which it consumes is independent of the size or efficiency of the radiators. In other words, the heat is used not for heating the radiator but rather the radiator acts as a medium for holding the heat until it can be discharged into the room."

Another Monument
to

**DUNNE PRIMER SEALER
and
DUNNE SATIN WALL**

The Best For
Looks - Protection - Economy

Inspect the
Alameda County Court House

FRANK W. DUNNE CO.
41st and Linden Sts. Oakland, Calif.
MAKERS OF GOOD PAINT

**REPUBLIC STEEL
CORPORATION**



Manufacturers of

ENDURO Stainless Steel; TON-CAN Copper Molybdenum Iron Sheets and Pipe; and Steel Pipe, Sheets and Reinforcing Bar for every building purpose.

Write for information

Rialto Building, San Francisco, Calif.
Edison Building, Los Angeles, Calif.
White-Henry-Stuart Bldg., Seattle, Wash.

**JOHN
CASSARETTO**

—Since 1886—And Still Active—

Building Materials

READY MIX CONCRETE
ROCK - SAND - GRAVEL - LIME
CEMENT - PLASTER - MORTAR
METAL LATH - WOOD LATH
STUCCO - WIRE NETTING

Service Unexcelled

Bunkers
Sixth and Channel, San Francisco
Phones: GARfield 3176, GARfield 3177

**THE TORMEY
COMPANY**

**GENERAL PAINTERS
AND DECORATORS**

Phone UNDERhill 1913

563 FULTON STREET
San Francisco

ARCHITECTS' AND ENGINEERS' SPECIFICATION INDEX

Classified Directory of Building Material Manufacturers, Dealers and Contractors

*Denotes subscriber of ARCHITECTS' REPORTS, sponsored and endorsed by State Association of California Architects, and published daily by THE ARCHITECT AND ENGINEER.

ACOUSTICAL AND SOUND CONTROL
RMSTRONG CORK PRODUCTS Co., 1355 Market Street, San Francisco.
JOHNS-MANVILLE Sales Corp., 116 New Montgomery Street, San Francisco.
EASTERN ASBESTOS Co., 675 Townsend Street, San Francisco.
RAMER Co., 50 Howard Street, San Francisco.
JRNER RESILIENT FLOORS, Inc., 141 New Montgomery Street, San Francisco.
ELOTEG Corp., 675 Townsend Street, San Francisco.

AIR CONDITIONING

T. JOHNSON Company, 940 Arlington, Oakland.
ELECTRIC APPLIANCES, Inc., 2001 Van Ness Avenue, San Francisco.
ALADDIN HEATING Corporation, 5107 Broadway, Oakland.
FRANK EDWARDS Co. (General Electric), 930 Van Ness Avenue, San Francisco.
GENERAL Air Conditioning & Heating Company, 4001 Piedmont Avenue, Oakland.

ARCHITECTURAL METAL SUPPLIES

BRAUN-STEEPLE Co., 636 Potrero Ave., San Francisco.

ARCHITECTURAL TERRA COTTA

I. CLARK & SONS, 116 Natoma Street, San Francisco.

LADDING McBEAN & Co., 9th and Harrison Streets, San Francisco; 2901 Los Feliz Boulevard, Los Angeles; 1500 First Avenue South, Seattle; 79 S. E. Taylor Street, Portland; 22nd and Market Streets, Oakland; 1101 N. Monroe Street, Spokane; Vancouver, B.C.

KRAFTILE COMPANY, Niles, California, and 525 Market Street, San Francisco.

BATHROOM HEATERS

VESIX ELECTRIC Heater Company, 390 First Street, San Francisco; 631 San Julian Street, Los Angeles; 2008 Third Avenue, Seattle, Wash.

BLINDS—VENETIAN

SUNN-CARLE & Co., 20 Potrero Avenue, San Francisco.

H. E. ROOT, 1865 California Street, San Francisco.

RY-LOCK Co., 1355 Market Street, San Francisco.

BOILERS AND PIPE

C. C. MOORE & Company, 450 Mission Street, San Francisco.

BRICK—FACE, COMMON, ETC.

N. CLARK & SONS, 116 Natoma Street, San Francisco.

LADDING McBEAN & Co., 9th and Harrison Streets, San Francisco; 2901 Los Feliz Boulevard, Los Angeles; 1500 First Avenue, South, Seattle; 79 S.E. Taylor Street, Portland; 22nd and Market Streets, Oakland; 1102 N. Monroe Street, Spokane; Vancouver, B.C.

BRASS

AMERICAN BRASS Co., Russ Building, San Francisco.

BUILDERS HARDWARE

THE STANLEY WORKS, New Britain, Conn.; Monednock Bldg., San Francisco; Los Angeles and Seattle.

***SCHLAGE LOCK Co.**, 20 Blaken Avenue, San Francisco.

***FARMER'S UNION**, 151 W. Santa Clara Street, San Jose.

***MAXWELL HARDWARE Company**, 1320 Washington Street, Oakland.

***P. and F. CORBIN**, New Britain, Conn.

BUILDING MATERIALS

BUILDING MATERIAL EXHIBIT, Architect's Building, Los Angeles.

***MELROSE BUILDING MATERIAL Co.**, 4501 Tidewater Avenue, Oakland.

***CONTRA COSTA BUILDING MATERIALS Company**, 2824 Shattuck Ave., Berkeley.

***MISSION BUILDING MATERIALS Co.**, Millbrae, Calif.

***RHODES & KENNEDY**, 101 4th Street, Oakland.

BUILDING PAPERS

THE SISALKRAFT Company, 205 W. Wacker Drive, Chicago, Ill., and 55 New Montgomery Street, San Francisco.

BUILDING PRODUCTS

"BASALITE" a lightweight, pre-fabricated material for floors, walls and roofs—Basalt Rock Co., Inc., Napa, California.

CABINET WORK

***FINK and SCHINDLER**, 552 Brannan Street, San Francisco.

MULLEN MANUFACTURING Co., 64 Rausch Street, San Francisco.

***MODERN FIXTURE & Cabinet Co.**, 59 Oak Grove Street, San Francisco.

CEMENT

***CALAVERAS CEMENT Company**, 315 Montgomery Street, San Francisco.

PORTLAND CEMENT Association 564 Market Street, San Francisco; 816 West Fifth Street, Los Angeles; 146 West Fifth Street, Portland; 518 Exchange Building, Seattle.

"GOLDEN GATE" and "OLD MISSION" manufactured by Pacific Portland Cement Co., 111 Sutter Street, San Francisco; Portland, Los Angeles and San Diego.

***HENRY COWELL Lime & Cement Company**, 2 Market Street, San Francisco.

***SANTA CRUZ PORTLAND Cement Company**, Crocker Building, San Francisco.

CEMENT—COLOR

"GOLDEN GATE TAN CEMENT" manufactured by Pacific Portland Cement Co., 111 Sutter Street, San Francisco; Portland, Los Angeles and San Diego.

CEMENT PAINT

FRANK W. DUNNE Company, 41st and Linden Streets, Oakland.

CHEMICAL ENGINEERS

ABBOT A. HANKS, Inc., 624 Sacramento Street, San Francisco.

ROBERT W. HUNT, 251 Kearny Street, San Francisco.

CLAY PRODUCTS

GLADDING McBEAN & Company, San Francisco, Los Angeles, Portland and Seattle.

N. CLARK & SON, San Francisco and Los Angeles.

KRAFTILE Company, Niles, California, and 525 Market St., San Francisco.

***GLADDING BROS. Mfg. Co.**, San Jose.

CLOCKS—ELECTRIC TIME

***INTERNATIONAL BUSINESS Machines Corp.**, 25 Battery Street, San Francisco.

CONCRETE AGGREGATES

GOLDEN GATE ATLAS Material Company, Sixteenth and Harrison Streets, San Francisco.

JOHN CASSARETTO, Sixth and Channel Streets, San Francisco.

***TRANSIT CONCRETE, Inc.**, 2500 Peralta Street, Oakland.

CONCRETE CURING & PROTECTION

THE SISALKRAFT Company, 205 W. Wacker Drive, Chicago, Ill., and 55 New Montgomery Street, San Francisco.

CONTRACTORS—GENERAL

LINDGREN & SWINERTON, Inc., Standard Oil Building, San Francisco.

DINWIDDIE CONSTRUCTION Co., Crocker Building, San Francisco.

CLINTON CONSTRUCTION Company, 923 Folsom Street, San Francisco.

ANDERSON & RINGROSE, 320 Market Street, San Francisco.

G. P. W. JENSEN, 320 Market Street, San Francisco.

***GEO. ARTHUR & SON**, 941 So. Claremont Street, San Mateo.

***A. T. BECKETT**, 224 Scenic Avenue Piedmont.

***L. M. G. PETERSON**, 520 Bowdoin Street, Palo Alto.

***BARRETT & HILP**, 918 Harrison Street, San Francisco.

DAMP-PROOFING & WATERPROOFING
"GOLDEN GATE TAN PLASTIC Water-proof Cement" manufactured by Pacific Portland Cement Co., 111 Sutter Street San Francisco; Portland, Los Angeles and San Diego.

DOOR HANGERS

PITCHER'S SLIDING DOOR HANGERS, Sheldon Building, San Francisco.

DOORS—HOLLOW METAL

FORDERER CORNICE Works, Potrero Avenue, San Francisco.

KAWNEER Mfg. Co., Eighth Street and Dwight Way, Berkeley.

ACID PROOF DRAIN PIPE

CORROSION—ACID resisting pipe, fittings exhaust fans, pumps, etc., Pacific Foundry Co., 3100 19th Street, San Francisco; 1400 S. Alameda Street, Los Angeles.

DRINKING FOUNTAINS

HAWS DRINKING FAUCET Co., 1808 Harmon Street, Berkeley; American Seating Co., San Francisco, Los Angeles and Phoenix.

ELECTRIC ADVICE

PACIFIC COAST ELECTRICAL Bureau, 447 Sutter Street, San Francisco, and 601 W Fifth Street, Los Angeles.

ELECTRIC FIXTURES

***THE FRINK Corporation**, 557 Market Street, San Francisco.

ELECTRICAL CONTRACTORS

***ALTA ELECTRIC and Mechanical Company** 467 O'Farrell Street, San Francisco

ELECTRICAL EQUIPMENT—SUPPLIES

***TRUMBULL ELECTRIC Mfg. Co.**, 260 Van Ness Avenue, San Francisco.

***GENERAL ELECTRIC Supply Corp.**, 1201 Bryant Street, San Francisco.

***NATIONAL ELECTRIC Products Co.**, 400 Potrero Avenue, San Francisco.

***WESTINGHOUSE ELECTRIC & Mfg. Co.**, 1 Montgomery Street, San Francisco.

ELEVATORS

***WESTINGHOUSE ELECTRIC Elevator Company**, 1 Montgomery Street, San Francisco.

***OTIS ELEVATOR Company**, Beach Street, San Francisco.

ENAMELING—PORCELAIN

FERRO ENAMELING Company, 1100 57th Street, Oakland.

FLOORING

ASPHALT TILE, Western Asbestos Company, 675 Townsend Street, San Francisco.

***JOHNS-MANVILLE Sales Corp.**, 116 New Montgomery Street, San Francisco.

MAPLE FLOORING MANUFACTURERS ASSOCIATION, McCormick Building, Chicago. Ask your lumber dealer.

LE ROY OLSON COMPANY, 3070 - 17th Street, San Francisco.

***LILLY & CROWLEY**, 123 Kansas Street, San Francisco.

FIXTURES—BANK, OFFICE, STORE

MULLEN MANUFACTURING Co., 64 Rausch Street, San Francisco.

PACIFIC MANUFACTURING Company, 454 Montgomery Street, San Francisco.

1315 Seventh Street, Oakland, Los Angeles and Santa Clara.

ARCHITECTS' AND ENGINEERS' SPECIFICATION INDEX

Classified Directory of Building Material Manufacturers, Dealers and Contractors

*Denotes subscriber of ARCHITECTS' REPORTS, sponsored and endorsed by State Association of California Architects, and published daily by THE ARCHITECT AND ENGINEER.

FURNITURE

*ALLIED ART GUILD, Menlo Park.
*PENN. FURNITURE Shops, Inc., 130 Second Avenue, San Mateo.

GAS BURNERS

VAUGHN-G. E. WITT Company, 4224-26 Hollis Street, Emeryville, Oakland.

GLASS

W. P. FULLER & Co., 301 Mission Street, San Francisco. Branches and dealers throughout the West.

LIBBEY-OWENS-FORD GLASS Co., Toledo, Ohio; 633 Rialto Building, San Francisco; 1212 Architect's Building, Los Angeles; 550 Skinner Building, Seattle.

PITTSBURGH PLATE GLASS Company, Grant Building, Pittsburgh, Pa. W. P. Fuller & Co., Pacific Coast Distributors.

*L. H. BUTCHER COMPANY, Fifteenth and Vermont Sts., San Francisco.

*EAST BAY GLASS Company, 621 Sixth Street, Oakland.

*COBBLEDDICK-KIBBE GLASS Company, San Francisco and Oakland.

HEATING—ELECTRIC

WESIX ELECTRIC Heater Company, 390 First Street, San Francisco; 631 San Julian Street, Los Angeles; 2008 Third Avenue, Seattle, Wash.

HEATING—GAS

PACIFIC GAS & ELECTRIC Co., 245 Market Street, San Francisco.

GENERAL Air Conditioning & Heating Company, 4001 Piedmont Avenue, Oakland.

HARER-PERRY Co., 5662 Keith Avenue, Oakland.

*W. H. PICARD, Inc., 4166 Broadway, Oakland.

*ALADDIN HEATING Corp., 22d and San Pablo Avenue, Oakland.

HEATING—OIL

S. T. JOHNSON Company, 940 Arlington, Oakland.

HEAT GENERATORS

*WATROLO CORPORATION, LTD., 1170 Howard Street, San Francisco.

HEATING & VENTILATING EQUIPMENT

*AMERICAN RADIATOR Company, 4th and Townsend Streets, San Francisco.

HEAT REGULATION

JOHNSON SERVICE Company, Milwaukee, represented on the Pacific Coast by the following branch offices: 814 Rialto Bldg., San Francisco; 153 West Avenue, 34, Los Angeles; 1102 N.W. Raleigh Street, Portland, and 473 Coleman Bldg., Seattle.

HOLLOW BUILDING TILE (Burned Clay)

N. CLARK & SONS, 116 Natoma Street, San Francisco.

GLADDING McBEAN & Co., 9th and Harrison Streets, San Francisco; 2901 Los Feliz Boulevard, Los Angeles; 1500 First Avenue South, Seattle; 79 S.E. Taylor Street, Portland; 22nd and Market Street, Oakland; 1102 N. Monroe Street, Spokane; Vancouver, B.C.

KRAFTILE Company, Niles, California, and 525 Market Street, San Francisco.

HOTEL AND RESTAURANT EQUIPMENT

*DOHRMANN HOTEL SUPPLY Company, 973 Mission Street, San Francisco.

INSPECTION AND TESTS

ABBOT A. HANKS, Inc., 624 Sacramento Street, San Francisco.

ROBERT W. HUNT Co., 251 Kearny Street, San Francisco.

INSULATION

CELOTEX Corp., 675 Townsend Street, San Francisco.

*JOHNS-MANVILLE Sales Corp., 116 N. Montgomery Street, San Francisco.

WESTERN ASBESTOS Co., 675 Townsend Street, San Francisco.

CABOT'S QUILT—Gunn, Carlo & Co., 20 Potrero Avenue, San Francisco.

VAPORSEAL, Mfg. by Celotex Corp., 919 N. Michigan Avenue, Chicago.

FIPTX of Northern California, 461 Market Street, San Francisco.

*GEORGE D. KARSCH, Builders Exchange, Sacramento, California.

INSURANCE

*FIREMAN'S FUND Insurance Company, 401 California Street, San Francisco.

INTERIOR DECORATORS

*REED DRAPERY SERVICE, 440 Post Street, San Francisco.

*M. H. WALES, 1933 Laguna Street, San Francisco.

*BETTY KENDALL, 251 Post Street, San Francisco.

KITCHEN EQUIPMENT

*MANGRUM, HOLBROOK & ELKUS, 301 Golden Gate Avenue, San Francisco.

DOHRMANN HOTEL SUPPLY CO., 972 Mission Street, San Francisco.

LACQUERS

W. P. FULLER & Co., 301 Mission Street, San Francisco. Branches and dealers throughout the West.

LIGHTING FIXTURES

*W. W. WARREN Company, 955 Mission Street, San Francisco.

*INCANDESCENT SUPPLY Company, 726 Mission Street, San Francisco.

*PHOENIX-DAY Company, 729 Mission Street, San Francisco.

LIMESTONE

*INDIANA LIMESTONE Company, 130 Lundo Way, San Francisco.

LINOLEUM CARPETS, Etc.

*WEST COAST LINOLEUM & CARPET Co., 1163 Market Street.

*VAN FLEET-FREAR Company, 557 Howard Street, San Francisco.

TURNER RESILIENT FLOORS, Inc., 141 N. Montgomery Street, San Francisco.

*D. N. & E. WALTER & Company, 562 Mission Street, San Francisco.

*CONGOLEUM-NAIRN, Inc., 1355 Market Street, San Francisco.

LOCKERS—METAL

*TRASK & SQUIER, 39 Natoma Street, San Francisco.

LUMBER

PACIFIC MFG. Co., 454 Montgomery Street, San Francisco; 1315 Seventh Street, Oakland; Los Angeles and Santa Clara.

SMITH LUMBER Company, Nineteenth Avenue and Estuary, Oakland.

MELROSE LUMBER & SUPPLY Co., Forty-sixth Avenue and E. Twelfth Street, Oakland.

E. K. WOOD LUMBER Company, 470 1/2 Santa Fe Avenue, Los Angeles; 1 Drumm Street, San Francisco; Frederick and King Streets, Oakland.

*SANTA FE LUMBER Company, 16 California Street, San Francisco.

FRIEND & TERRY LUMBER Co., Front & S Streets, Sacramento.

*OAKLAND LUMBER Co., 6901 E. 14th Street, Oakland.

MACHINERY—PUMPS, Etc.

SIMONDS MACHINERY Company, 816 Folsom Street, San Francisco.

MARBLE

JOSEPH MUSTO SONS-KEENAN Co., 535 N. Point Street, San Francisco.

MILLWORK

E. K. WOOD LUMBER Company, No. 1 Drumm Street, San Francisco, Oakland, Los Angeles.

LANNON BROS. Mfg. Co., Fifth and Magnolia Streets, Oakland.

MELROSE LUMBER & SUPPLY Company, Forty-sixth Avenue and E. Twelfth Street, Oakland.

PACIFIC MFG. Co., 454 Montgomery Street, San Francisco; 1315 Seventh Street, Oakland; Los Angeles and Santa Clara.

SMITH LUMBER Company, Nineteenth Avenue and Estuary, Oakland.

*WESTERN DOOR and SASH Company, 5th and Cypress Streets, Oakland.

*OAKLAND PLANING MILL, 105 Washington Street, Oakland.

*T. P. HOGAN Company, 2d and Alice Streets, Oakland; 630 Mission Street, San Francisco.

*SAN MATEO PLANING MILL, San Mateo.

MONEL METAL

"INCO" BRAND, distributed on the Pacific Coast by the Pacific Metals Company, 3100-19th Street, San Francisco, and 1400 So. Alameda Street, Los Angeles.

*OAKHEAD METAL APPLIANCE CO., 4238 Broadway, Oakland.

NURSERY STOCK

*C. J. BURR, 305 Lytton Avenue, Palo Alto.

*CALIFORNIA NURSERIES, Niles.

OIL BURNERS

*SAN MATEO FEED and FUEL Company, San Mateo, Cal.

S. T. JOHNSON Co., 585 Potrero Avenue, San Francisco; 940 Arlington Street, Oakland; 1729 Front Street, Sacramento, and 1020 El Camino Real, San Carlos, Calif.

VAUGHN-G. E. WITT Co., 4224-26 Hollis Street, Emeryville, Oakland.

*HORABIN OIL & BURNER Company, 234 Hamilton Avenue, Palo Alto.

PAN-AMERICAN SIMPLEX OIL BURNER, 820 Parker Street, Berkeley.

ONYX

JOSEPH MUSTO SONS-KEENAN Co., 535 N. Point Street, San Francisco.

ORNAMENTAL IRON

INDEPENDENT IRON WORKS, 821 Pine Street, Oakland.

PAINTING, DECORATING, Etc.

THE TORMEY Co., 563 Fulton Street, San Francisco.

*RAPHAEL COMPANY, 270 Tehama Street, San Francisco.

PAINTS, OIL, LEAD

W. P. FULLER & CO., 301 Mission Street, San Francisco. Branches and dealers throughout the West.

FRANK W. DUNNE Co., 41st and Linden Streets, Oakland.

NATIONAL LEAD Company, 2240-24th Street, San Francisco. Branch dealers in principal Coast cities.

*SHERWIN-WILLIAMS Company, 1415 Sherwin Avenue, Oakland.

*WALTER N. BOYSEN PAINT CO., 42nd and Linden Street, Oakland.

PARTITIONS—MOVABLE OFFICE

PACIFIC MFG. Co., 454 Montgomery Street, San Francisco; 1315 Seventh Street, Oakland; factory at Santa Clara.

PLASTER

"EMPIRE" and "RENO HARDWARE PLASTER," manufactured by Pacific Portland Cement Co., 1111 Sutter Street, San Francisco; Portland, Los Angeles and San Diego.

ARCHITECTS' AND ENGINEERS' SPECIFICATION INDEX

Classified Directory of Building Material Manufacturers, Dealers and Contractors

*Denotes subscriber of ARCHITECTS' REPORTS, sponsored and endorsed by State Association of California Architects, and published daily by THE ARCHITECT AND ENGINEER.

PLASTERING CONTRACTOR
AMES F. SMITH, 271 Minna Street, San Francisco.

PLASTER—ACOUSTICAL
LACOSTIC, Sound Absorbing Plaster, manufactured by Pacific Portland Cement Co., 111 Sutter Street, San Francisco, Los Angeles and San Diego.

PLASTER MATERIALS
S. GYPSUM Company, Architect's Building, Los Angeles.

PLATE GLASS
BEY-OWENS-FORD GLASS Co., Toledo, Ohio; 633 Rialto Building, San Francisco; 1212 Architect's Building, Los Angeles; Mr. C. W. Holland, P.O. Box 3142, Seattle.

PLUMBING CONTRACTORS
L. T. DOELL, 467-21st Street, Oakland.
COTT Company, 243 Minna Street, San Francisco.

V. H. PICARD, 4166 Broadway, Oakland.

PLUMBING FIXTURES AND SUPPLIES
LANE Co., all principal Coast cities.
STANDARD SANITARY Manufacturing Company, 278 Post Street, San Francisco.
WALWORTH CALIFORNIA Company, 665 Sixth Street, San Francisco.
V. R. AMES Co., 150 Hooper Street, San Francisco.
LY-HOLBROOK, Inc., 165 Eighth Street, San Francisco.

PRESSURE REGULATORS
LAUGHN-G. E. WITT Co., 4224-28 Hollis Street, Emeryville, Oakland.

PUMPS
MONDS MACHINERY Company, 816 Folsom Street, San Francisco.

REFRIGERATION
ALCO-FRIGIDAIRE ELECTRIC REFRIGERATORS, Aladdin Heating Corp., 22d and Broadway, Oakland.

ROOFING CONTRACTORS
MALLOTT & PETERSON, 2412 Harrison Street, San Francisco.

ROOFING INSULATION
OHNS-MANVILLE Sales Corp., 116 New Montgomery Street, San Francisco.

ROOF MATERIALS
OHNS-MANVILLE Sales Corp., 116 New Montgomery Street, San Francisco.
IONEER FLINTKOTE Company, Shell Building, San Francisco.

ARAFFINE Company, Inc., 475 Brannan Street, San Francisco.

LADDING McBEAN & Co., 9th and Harrison Streets, San Francisco; 2901 Los Feliz Boulevard, Los Angeles; 1500 First Avenue South, Seattle; 79 S.E. Taylor Street, Portland; 22nd and Market Street, Oakland; 1102 N. Monroe Street, Spokane; Vancouver, B.C.

MARSHALL SHINGLE Company, 608-16th Street, Oakland.

CLARK & SONS, 112-116 Natoma Street, San Francisco; works, West Alameda.

CERTAIN-TEED PRODUCTS Co., 315 Montgomery Street, San Francisco.

SAFES
ERRING-HALL-MARVIN SAFE Co., 214 California Street, San Francisco.

SAND, ROCK AND GRAVEL
OHN CASSARETTO, Sixth and Channel Streets, San Francisco.
ASALT ROCK Co., Napa.

ASISER PAVING Company, Latham Square Building, Oakland.

ELROSE BUILDING MATERIAL Co., 4501 Tidewater Avenue, Oakland.

SCREENS
ROLL-AWAY WINDOW SCREEN Company, Eighth and Carlton Streets, Berkeley; 557 Market Street, San Francisco.

SEATING
*HEYWOOD-WAKEFIELD Co., 180 New Montgomery Street, San Francisco.
*GENERAL SEATING Company, 160 Second Street, San Francisco.

SHADE CLOTH
CALIFORNIA SHADE CLOTH Co., 210 Bayshore Boulevard, San Francisco.

SHINGLE STAINS
CABOT'S CREOSOTE STAINS, Gunn-Carle & Co., 20 Potrero Ave., San Francisco.

AUTO SPRINKLERS
GLOBE AUTOMATIC SPRINKLER Co., 665-6th Street, San Francisco.

STANDARD STEEL BUILDINGS
INDEPENDENT IRON WORKS, 821 Pine Street, Oakland.

STEEL FURNITURE
*GENERAL FIREPROOFING Company, 160 Second Street, San Francisco.

STEEL—REINFORCING
*SOULE STEEL Company, Army Street, San Francisco and Los Angeles.
GUNN-CARLE Company, Portrero Avenue, San Francisco.

CECO STEEL PRODUCTS Co., 1280 Indiana Street, San Francisco.
*W. C. HAUCK & Co., 280 San Bruno Avenue, San Francisco.

*TRUSCON STEEL Company, 604 Mission Street, San Francisco.

STEEL—STAINLESS
REPUBLIC STEEL Corporation, Rialto Building, San Francisco; Edison Building, Los Angeles; White-Henry-Stuart Building, Seattle.

STEEL—STRUCTURAL
INDEPENDENT IRON WORKS, 821 Pine Street, Oakland.

JUDSON PACIFIC Company, C. F. Weber Building, Mission and Second Streets; San Francisco shops, San Francisco and Oakland.

HERRICK IRON WORKS, 18th and Campbell Streets, Oakland.

*MOORE DRYDOCK Company, Foot of Adeline Street, Oakland.

*WESTERN IRON WORKS, 141 Beale Street, San Francisco.

COLUMBIA STEEL Company, Russ Building, San Francisco.

STORE FIXTURES
MULLEN MFG. Co., 60 Rausch Street, San Francisco.

STORE FRONTS
ZORI STORE FRONTS, Niles, Michigan.
KAWNEER MFG. Co., Eighth Street and Dwight Way, Berkeley.

STUCCO NETTING—WELDED
"WELDWEAVE," E. H. EDWARDS CO., 200 Bush Street, San Francisco; 620 E. 61st Street, Los Angeles; 1252 6th Avenue S., Seattle; 2690 N.W. Nicolai Street, Portland.

TEMPERATURE REGULATION
JOHNSON SERVICE Company, Milwaukee represented on the Pacific Coast by the following branch offices: 814 Rialto Building, San Francisco; 153 West Avenue, 34, Los Angeles; 1312 N.W. Raleigh Street, Portland, and 473 Coleman Building, Seattle.

TELEPHONES—INTERCOMMUNICATING
*PACIFIC TELEPHONE and TELEGRAPH Company, 140 New Montgomery Street, San Francisco.

TERMITE CONTROL—WOOD PRESERVATIVE
E. K. WOOD LUMBER Company, No. 1 Drumm Street, San Francisco; 4701 Santa Fe Avenue, Los Angeles; Frederick and King Streets, Oakland.
J. H. BAXTER & COMPANY, 333 Montgomery Street, San Francisco.

TILE—DECORATIVE, Etc.
*CAMBRIDGE TILE Mfg. Co., 1155 Harrison Street, San Francisco.
POMONA TILE MFG. Co., plant, Pomona, Cal.; Sales Rooms, 135 Tenth Street, San Francisco; 217 S. La Brea Avenue, Los Angeles; 6106 Roosevelt Way, Seattle.

GLADDING McBEAN & Co., 9th and Harrison Streets, San Francisco; 2901 Los Feliz Boulevard, Los Angeles.
KRAFTLE Company, Niles California, and 525 Market St., San Francisco.

*CALIFORNIA ART TILE Corp., Richmond, Cal.

TILE CONTRACTORS
*CAMBRIDGE WHEATLEY Company, 1155 Harrison Street, San Francisco.

TREE SURGERY
DAVEY TREE SURGERY Co., Ltd., Russ Building, San Francisco; Story Building, Los Angeles.

TRUSSES
*SUMMERBELL TRUSS Company, 405 Builders Exchange Building, Oakland.
*ARCH-RIB TRUSS Company, 608 Sixteenth Street, Oakland.

VALVES
"KRAMER" Flush Valves, MacDonald Hardware Manufacturing Co., 963 Harrison Street, San Francisco.
SLOAN VALVE Company, Chicago, Ill.
SHAND AND JURS Co., Eighth and Carlton Streets, Berkeley.

VARNISHES
NATIONAL LEAD Company, 2240-24th Street, San Francisco. Branches and dealers in all principal Coast cities.
W. P. FULLER Company, San Francisco and principal Coast cities.

FRANK W. DUNNE Co., 41st and Linden Streets, Oakland.

VENTILATING EQUIPMENT
*THE B. F. STURTEVANT Company, 759 Monodneck Building, San Francisco.

WALL BOARD
*WESTERN BUILDERS SUPPLY Company, 401 Fourth Street, San Francisco.

WATER HEATERS—GAS AND ELECTRIC
*WATROLA Corporation, Ltd., 1170 Howard Street, San Francisco.
*PITTSBURG WATER HEATER Co., 898 Van Ness Avenue, San Francisco.

*RUUD HEATER Company, 437 Sutter Street, San Francisco.
WESIX ELECTRIC HEATER Company, 380 First Street, San Francisco.

WINDOW SASH AND FIXTURES
"DALMO," SIMPLEX and "HAUSER" Casement Windows, MacDonald Hardware Mfg. Co., 963 Harrison Street, San Francisco.

*DETROIT STEEL PRODUCTS Co., 111 Sutter Street, San Francisco.

KAWNEER MFG. Company, Dwight Way and Eighth Street, Berkeley.

UNIVERSAL WINDOW COMPANY, (Donovan) 950 Parker Street, Berkeley.

WINDOW SHADES
AEROSHADE Company, represented by W. R. Knight, 557 Market Street, San Francisco.
CALIFORNIA SHADE CLOTH Co., 210 Bayshore Boulevard, San Francisco.

INDEX TO ADVERTISEMENTS

*Indicates Alternate Months

A		K	
ALADDIN Heating Corp.	67	KAWNEER Company	3
AMERICAN Brass Company	10	KRAFTILE Company	67
ANACONDA Copper Company	10		
ANDERSON & Ringrose	74	L	
ARCHITECTS Building	70	LANNOM Bros. Manufacturing Company	74
		LIBBEY, Owens, Ford Glass Company	*
B		LINDGREN & Swinerton, Inc.	69
BASALT Rock Company	70		
BAXTER & Company, J. H.	68	M	
BUILDING Material Exhibit	70	MacDONALD Hardware Manufacturing Company	6
		MAPLE Flooring Manufacturers Association	*
C		MERCURY Press	76
CASSARETTO, John	76	MULLEN Manufacturing Company	71
CLARK, N., and Sons	*	MUSTO Sons Keenan Company, Joseph	75
CLINTON Construction Company	74		
CRANE Company	*	N	
CROCKER First National Bank	73	NATIONAL Lead Company	67
CROCKER, H. S.	71		
		P	
D		PACIFIC Coast Gas Association	3rd Cover
DAVEY Tree Surgery Company	70	PACIFIC Coast Electrical Bureau	65
DELCO-FRIGIDAIRE	67	PACIFIC Foundry Company, Ltd.	69
JINWIDDIE Construction Company	75	PACIFIC Manufacturing Company	72
DOELL, Carl T., Company	75	PACIFIC Portland Cement Company	2nd Cover
DUNNE Company, Frank W.	76	PAN-AMERICAN Engineering Co.	73
		PITCHER Company, E. C.	74
F		PITTSBURGH Plate Glass Company	9
FERRO-PORCELAIN Building Co.	74	PORTLAND Cement Association	Back Cover
FULLER Company, W. P.	9		
FORDERER Cornice Works	73	R	
		REPUBLIC Steel Corporation	76
G			
GLADDING, McBean & Company	11	S	
GOLDEN Gate Atlas Materials Company	72	SANTA Maria Inn	71
GUNN, Carle & Company	2	SIMONDS Machinery Company	72
		SISALKRAFT Company	72
H		SLOAN Valve Co.	*
HANKS, Inc., Abbot A.	76	SMITH Lumber Company	75
HARER-Perry Company	70	STANLEY Works	68
HAWS Drinking Faucet Company	72		
HERRICK Iron Works	73	T	
HOLBROOK, J., Inc.	75	TORMEY Company, The	76
HOLLEY Manufacturing Co.	70		
HOTEL CLAREMONT	71	U	
HOTEL CLARK	75	UNIVERSAL Window Company	72
HUNT, Robert W. Company	71		
HUNTER and Hudson	71	V	
		VAUGHAN-G. S. Witt Company	76
I			
INCANDESCENT Supply Company	70	W	
INDEPENDENT Iron Works	74	WESIX Electric Heater Company	73
		WOOD, E. K., Company	66
J		WESTERN Asbestos Company	70
JENSEN & Son, G. P. W.	71		
JOHNSON, S. T., Company	66	Z	
JOHNSON Service Company	7	ZOURI Store Fronts	3
JUDSON Pacific Company	70		

THE
ARCHITECT
AND
ENGINEER

JULY 1938

Recent Work of Portland, Oregon, Architects



In the
LONGEST BRIDGE

Crossing the long arm of lower San Francisco Bay is the San Mateo-Hayward Bridge — longest in the world, 12 miles. * Towering above the surrounding landscape like a giant finger, at Selby, California, is the new concrete stack of American Smelting & Refining Co. — highest in the world, 605 feet. * Delving deep into the very bowels of the earth at Wasco, California, is the No. K.C.L.A.-2 well of the Continental Oil Company — deepest in the world, 15,001 feet.

The
**HIGHEST
STACK**

For all three of these unmatched engineering achievements of man, Golden Gate Cements were specified and used exclusively. * Thus, as the world looks to the Pacific Coast for outstanding projects, the Coast looks to Golden Gate Cement for outstanding performance and unqualified assurance of permanence.

The
**DEEPEST
OIL WELL**

Whether you are planning a structure of record-breaking magnitude or merely a foundation for a house, it will pay you, too, to specify and use "Golden Gate Cement for Sound Construction."

Ask Your Building Material Dealer

**GOLDEN
GATE
CEMENTS**
were used
EXCLUSIVELY

Produced by

San Francisco
Los Angeles

PACIFIC PORTLAND CEMENT COMPANY

Portland
Seattle

COASTWIDE SERVICE

The JULY 1938

ARCHITECT & ENGINEER

Fred W. Jones, Editor

Mark Daniels, A. I. A., Associate Editor

Glenn Stanton, A. I. A., Guest Editor

CONSULTING BOARD
OF EDITORS

Contents

FRONTISPIECE

Architectural—

- Arthur Brown, Jr.
- Frederick H. Meyer
- Timothy L. Pilueger
- Will G. Corlett
- Harry Michelsen
- Lewis P. Hobart
- David C. Allison
- Gordon B. Kaufmann
- Harris C. Allen

**ENTRANCE PORCH, HOUSE FOR MR. AND MRS. FRANK MEIER,
CLACKAMAS RIVER, OREGON**

Hollis Johnson and Herman Brookman, Architects

TEXT

RUNNING FIRE	3
Mark Daniels, A. I. A.	
WHAT THE OREGON ARCHITECTS HAVE BEEN DOING	13
Glenn Stanton, A. I. A., Guest Editor	
THROUGH A MONOCLE	43
Harry Sanders, Jr., B. Arch.	
RECENT TRENDS IN LIBRARY ARCHITECTURE	45
Carl B. Roden	
WORLD'S FAIR BUILDERS—WM. GLADSTONE MERCHANT	48
PARABLE ON STYLE	49
Irving F. Morrow, Architect	
PACIFIC COAST ARCHITECTS' CHAPTERS	51
WITH THE ARCHITECTS	53

Engineering—

- H. J. Brunner
- L. H. Nishkian
- William Adrian
- Wm. H. Popert
- Homer N. Hadley
- Geo. E. Atkins

PLATES AND ILLUSTRATIONS

Domestic

House for Mr. Lloyd Babler	13	Residence of F. W. Cutler	18
House for Dr. Millard Rosenblatt	14	Residence for Frank Kiernan	19
House for Mrs. M. J. Sammons	14	House for Spencer Biddle	21
House for Dr. Frank B. Kistner	15	Two Portland Heights Houses	22
Residence of Dr. Richard Wells	15	Town Club, Portland	23
House for Irvin G. Reinke	16	Residence for Mr. and Mrs. Robert Arneson	24
Residence of Wade Newbegin	17		

Public

Timberline Lodge, Mt. Hood	27	Klamath Falls Armory	31
Tuberculosis Hospital	29	Nurses Homes, Good Samaritan Hospital	33
Mortuary Building for Hennessey, Goetsch & McGee	30	Finley's Mortuary	35-36
City Hall, Canby	31	Art Museum	36

Commercial

Clinic Building for Dr. E. H. McLean	20	Store for Burnett Bros.	40
Jantzen Knitting Mills	32	Deady Building Alterations	41
Fifth Avenue Shop, Portland	37	Regent Apartments	41
Stone-Margulis Store, Portland	40	Klamath Falls Bank	42

Ecclesiastical

St. George's Episcopal Church	34	St. Mary's Episcopal Church	34
---	----	---------------------------------------	----

Educational

Library, University of Oregon	28	All Saints' School, Portland	38
Library, Willamette University	37	Senior High School, Salem	38-39

Landscape

Garden of Mrs. T. B. Wilcox	26	Garden of Mrs. Inc. B. Yeon	26
---------------------------------------	----	---------------------------------------	----

Assistant Editor—

Edgar N. Kierulff

Advertising Manager—

J. Leslie Meek

Architects' Reports—

Vernon S. Yallop

THE ARCHITECT AND ENGINEER, INC., 68 Post Street, San Francisco, EXbrook 7182. President, K. P. Kierulff; vice-president, Frederick W. Jones; secretary, L. B. Penhorwood. Los Angeles office, 832 W. Fifth Street. Published on the 12th on each month. Entered as second class matter, November 2, 1905, at the Postoffice at San Francisco, California, under the Act of March 3, 1897. Subscriptions, United States and Pan America, \$3.00 a year; Foreign countries, \$5.00 a year; single copy, \$.50.

IT'S EASY TO MAKE KITCHENS *More Livable*



The Crane Kitchen Queen Sink well deserves its title—"America's finest sink." Every bit of space is efficiently utilized in this sink. The large compartments make dishwashing easy; and the depressed drainboard prevents water surging over the rim. Comfort angle supply panel keeps controls out of the way, yet right at the finger tips when wanted. Recessed center panel permits correct posture.

with CRANE Sinks

THE kitchen has been promoted! It is no longer a room just intended for cooking. Of course, Mrs. America today wants a livable, humanized kitchen; and besides, she may want a place to iron, or perhaps she likes the convenience of a breakfast bar.

But in making the kitchen pleasant and homelike—there must be no sacrifice in efficient arrangement. The floor plan should be considered from the standpoint of saving steps, and all materials used must serve the functional need for which they are intended, most effectively.

In the sink, for example, it is possible to emphasize the color scheme for the kitchen, making this room as bright and interesting as any in the house. For Crane Porcelain Enamel Sinks come in a wide variety of colors as well as in black and white. Then, too, any client will be more than pleased with the beauty of gleaming porcelain enamel—so easy to clean and keep clean. That smooth, lustrous surface never shows a trace of stains or fingerprints and, as the years roll by, the surface of a Crane sink remains bright and shining.

If you are interested in making kitchens gayer, drop into the nearest Crane Branch and see how well Crane's newest sinks, in these modern colors, will fit into your plans.

Crane Co. has made a comprehensive study of basic bathroom types and fixture arrangements, as well as color effects obtainable in standard materials. All this information is contained in the Crane Bathroom Planner—a wealth of practical bathroom planning information immediately available to architects.



Perfected automatic heating for coal, oil or gas is offered by the Crane line of heating products, each designed for maximum efficiency and economy.

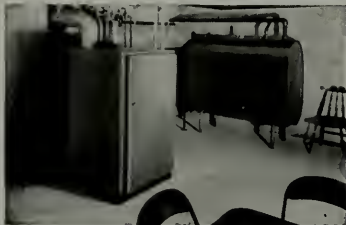

CRANE VALVES FITTINGS
PIPE • PLUMBING
HEATING • PUMPS

CRANE CO., GENERAL OFFICES: 838 SOUTH MICHIGAN AVE., CHICAGO

NATION-WIDE SERVICE THROUGH 134 BRANCHES AND MORE THAN 500 WHOLESALEERS

RUNNING FIRE

by
MARK DANIELS, A.I.A.

Mental Calisthenics

We architects are forever being cursed of a lack of imagination. I cannot get the basement on the roof and the attic in the basement, we are dumb. If we cannot design a shop front that will quadruple, overnight, the business of a merchant engaged in trying to sell dried radishes, we have no imagination.

In all fairness, there is merit to the complaint in some instances. So I have devised certain exercises in imagination—calculated to develop that mental attribute to the nth degree.

1. Try to imagine Tim Pflueger at home in a Baroque boudoir.
2. Picture, if you can, Arthur Brown, Jr. living in a Frank Lloyd Wright bungalow.
3. Think of Charley Purcell building an arch superior for an orthopedist.

If you can do these exercises you are qualified to design a Turkish bath that will function perfectly as a first class convent.

* * *

Just Two Grains Of Corn, Lather

I want to see a garden where the bees look happy and the saplings sway with the wind, but I don't know where to look for it.

I want to find a house where the doors invite entrance and the windows are placed to admit light into rooms occupied by people who like to look out of windows, but I don't know where it is.

I want to write a book that will be free from swastikas and slaves, Russians and rape, fools and Fascism. I want to take my readers back to the day when men sang to the tempo of the mallet and the riel rather than to the beat of the meral drum, but I don't know how.

* * *

Map Judgment

There were two men just ahead of me passing from picture to picture that hung on the walls of a

small gallery. At one canvas they paused long enough for the man on the right to say "That's lousy," and for the other to smack his aesthetic lips in agreement. I followed them because I have a penchant for eavesdropping.

When the brave critics had gone, I returned to the "lousy" canvas. After a few moments it looked pretty good. Soon I began to like it. There was a simplicity of composition and a restraint in technique that was restful. The artist knew when to quit.

As I thought of the "lousy" criticism I recalled the courteous but cogent reply of my friend Andrew, a waiter at the club, to a guest who asked if Andrew recognized him as the person who was two seas over a few nights before. Andrew's reply was "I never develop a final picture on one exposure."

* * *

Censor Wanted

By gosh, we're getting there. Every day, in every way, we're getting purer and purer. We are censoring plays, dictionaries, radios, music, the press and public soup spoons. We are starting to enforce the draping of the human figure in architecture, and there is a movement to prohibit deaf mutes from carrying on public conversation unless they wear antiseptic gloves.

* * *

Faith

A friend of mine spent thirty years in research work, seeking proof of miraculous cures, the formula for happiness and the explanation of contentment. He was not actuated by mere curiosity nor did he proceed in an untrained or haphazard manner. He had earned both his M.S. and his Ph.D. in archaeology and psychology. Years on end he spent in Egypt and the Holy Land, India and China. His faith in biblical miracles and similar phenomena seemed to be unshakable.

One day, not long ago, he dropped into the easy chair in my library. He looked so dejected, so disconsolate and so different from the man I had known for years that my first question was whether he was ill, or had picked up a fever in the tropics. He replied, "No, physically I am all right. But I am beginning to think that this life work of mine is a lot of nonsense. I am beginning to doubt the value of it all."

I thought he had merely gone stale until I talked to my friend Andrew about it. When I had told Andrew the whole story of a lost ambition, he cast a ruminative eye upward and said, "Many men struggle so hard to gain a knowledge of things that they lose faith in them."

Since then I have attacked my problems with renewed faith and less fuss.

* * *

Nature In 1938

At the aquarium, sea urchins, striped fish, creatures with lanterns in their noses and double-ended wiggling things were passing in endless parade behind the glass front of the tanks.

Nearby was a biped who should have been on the other side of the glass—one of those who think that a rubber ball is a marvel of nature. As I came near he turned and said, "Marvelous age we're living in, eh, buddy?"

* * *

A Narrow Escape

If you find that your favorite magazine or, say, "Running Fire," bores you, stroll through the shopping street between noon and one o'clock and you will have a fair chance of getting a few laughs.

Yesterday, as I stood near a corner, two gushing gals met on the curb. "Oh! Agnes! I'm so thrilled to see you," said one. "I've been thinking of you all day. Can you believe it, darling, I almost rang you up this morning!"

HEAVENS!

EVERYWHERE GLASS DOMINATES DESIGNS ...



Interior design by Paul MacAlister, A.I.D.

Grosfeld House Exhibition, New York.

Glass has long contributed its remarkable utility and charm to every type of residential construction. Today—it is a dominant feature of architectural design and interior decoration.

Here, an intriguing curved window of peach color plate glass adds a delicate mellowness to the view reflected in the large peach mirror above the mantel. Of striking decorative beauty, this mirror lends its subtle inference of greater spaciousness within—brightens far corners and repeats engaging colors. A further contribution to the colorful yet dignified decorative scheme is found in the fireplace faced with maroon Vitrolux, the new color fused tempered plate glass. With the many modern effects to be obtained with glass, its quality becomes a matter of paramount importance. Libbey-Owens-Ford Quality Glass is today, as it has been for many years, unexcelled by any that the industry has ever offered.

LIBBEY-OWENS-FORD GLASS COMPANY, TOLEDO, OHIO



LIBBEY · OWENS · FORD  QUALITY GLASS

NEVER GETS OUT OF ADJUSTMENT BECAUSE...there's nothing to adjust



● The multiplication table never varies . . . nor do Sloan Royal Flush Valves—even after many years of constant use. Because, with the Sloan "Royal" there is nothing to adjust. Exact, unvarying water measurement is the function of the Royal—so simple in design and positive in performance there is neither use nor place for an adjustment set-screw.

Specify Sloan Valves for your building, the kind that saves water and cuts maintenance costs to the irreducible minimum . . . The kind that (for years) has been sold and installed in greater numbers than all other makes combined.

SLOAN VALVE COMPANY • CHICAGO



SLOAN *Flush* VALVES

MAKERS ALSO OF THE "STAR"  "NAVAL"  AND "CROWN"  VALVES



William Wilson Wurster

Direct, honest solutions—free from affectation—have won national recognition for the work of William Wilson Wurster. Featuring his work in its May, 1936, edition, Architectural Forum said: "His houses not only have a remarkable range of expression but, by virtue of their adaptability to special conditions, possess a strong local character which can today be found in the work of few men."

Mr. Wurster was born in Stockton, California, and studied architecture at the University of California. He has traveled in Hawaii, the Philippines and the Orient, and has lived in Europe and New York. His first work in America was in the San Francisco office of John Reid. In 1926 Mr. Wurster opened his own office in San Francisco. One reason for the wide acceptance of his work is that he never feels he must put over a given expression.



Flexibility of design possible with Douglas Fir Plywood adds charm to the walls and ceiling of a bedroom in this Wurster-designed home at Carmel, Calif.

**"Flexibility of design
and adaptability to
alterations are high
points in the use of
DOUGLAS FIR
PLYWOOD"**

...William Wilson Wurster

DOUGLAS FIR PLYWOOD is one material that places few limitations on the architect. It is practical for both exterior and interior use. And it combines the unusual strength of cross-grained lamination—light weight—low cost—and the labor saving advantages of large panels.

Specify Douglas Fir Plywood for wall and roof sheathing and sub-floors in home construction. You'll add extra strength and rigidity to the structure—substantially reduce labor costs. For interior finishing Douglas Fir Plywood is adaptable to practically any use—wall paneling, cabinet work, built-ins, ceiling and walls of playrooms, etc.

Douglas Fir Plywood Concrete Form panels allow the architect freedom of expression in designing mass structures. They give a smooth finish with minimum joints, sharply reduce

rubbing and finishing costs—and can be reused repeatedly.

Stock panels of Douglas Fir Plywood (3, 5 and 7 ply) are manufactured in various thicknesses, as large as 4 x 8 feet, and even larger on special order. Standard grades include Wall-board, Sheathing, Standard Panel and Concrete Form. Special grades can be obtained for any building and industrial need, including hot-pressed, resin-bonded plywood for permanent exterior exposures.

Sweet's Catalog contains complete data on Douglas Fir Plywood. Our well-equipped Technical Division offers cooperation to architects, engineers and others in adapting Douglas Fir Plywood to special problems and recommending the proper types and grades to produce utmost serviceability and economy. Address DOUGLAS FIR PLYWOOD ASSOCIATION, Tacoma Building, Tacoma, Washington.

**DOUGLAS FIR
PLYWOOD**

Real Lumber
**MADE LARGER, LIGHTER
SPLIT-PROOF
STRONGER**



Answering the Dry Construction Problem



★ When architects began looking for something to solve the dry construction demand, they naturally turned first to wood paneling or veneers. But the joint problem handicapped plywood for years. It was not until Art-Ply came out with a sealed and concealed joint that architects said, "here is the answer."

ART-PLY NOW PROVED BY TEST

Some of America's finest homes have installed Art-Ply in living rooms, dining rooms, bedrooms, kitchens and baths. The decorative effects have been as varied as the uses. That is one of the nice things about Art-Ply. It takes any finish wood will take; and a newly developed sealer eliminates all possibility of checking and grain raising.

Art-Ply saves time and lowers cost of construction and heating. The surface is durable and lasting. See Art-Ply 12-page insert in Sweet's Catalogue.

Western Distributors who stock ART-PLY

Lumber Supply & Warehouse Co. Seattle	Diamond Match Co. Chico
W. P. Fuller & Co. Seattle, Portland, Tacoma	San Pedro Lumber Co. Los Angeles
Nicolai-Neppach Co. Portland	Hammond Lumber Co. Los Angeles
J. E. Higgins Lumber Co. San Francisco	E. K. Wood Lumber Co. Los Angeles
Strable Hardware Co. Oakland	Sullivan Hardwood Lumber Co. San Diego
	J. G. Doerr Co. Boise



ARTEPLY
THE INLAID PLYWOOD

Art-Ply inlaid multi-paneled sections come in four standard patterns. Sizes 4 ft. x 8 ft.; 3-ply thickness durable Douglas Fir.

VANCOUVER PLYWOOD & VENEER COMPANY

Vancouver, Washington, U. S. A.

Gentlemen: Please send me more information about Art-Ply.

Name.....

Address.....

AE-1

For Lasting Beauty

IN

Craftsmanship in Metal

OREGON BRASS WORKS ARCHITECTURAL METAL

*Universally Preferred by
Northwest Architects*



Plant of OREGON BRASS WORKS, Portland, Oregon.
Largest Architectural and Ornamental Metal Factory
in the Pacific Northwest.

Illustrated in this issue are but a few of many outstanding buildings in the Pacific Northwest where ORNAMENTAL METAL by OREGON BRASS WORKS was used because of its exceptional beauty, craftsmanship and lasting quality.

Office, Jantzen Knitting Mills
Portland, Ore. Page 32

Stone-Margulis, Jewelry Store
Portland, Ore. Page 40

Burnett Bros., Jewelry Store
Portland, Ore. Page 40

OREGON BRASS WORKS
S. E. 10TH AND SALMON PORTLAND, ORE.

PULSE OF THE READER

OPPOSED TO UNIFICATION

Dear Mr. Editor:

We have received a copy of The Architect and Engineer, containing an article by Mr. Harry M. Michelsen, entitled "Unification of the Architectural Profession." In the article, Mr. Michelsen states concerning the address of the president of the American Institute of Architects at the Seventieth Convention.

"His message eminently brought forth the desire that unification be given sincere consideration, with the thought in mind that a friendly relationship may be established between the national group and State Associations."

This Chapter believes that the so-called "unification" movement that is being promoted within the Institute is confusing and unnecessary. We believe that the State Associations and the American Institute of Architects should work in friendly cooperation on all matters of mutual interest, but that they should maintain their separate identities without affiliation, however tenuous. We believe that the words of the president at the Convention, which are quoted in the enclosed copy of a resolution, unanimously adopted at our recent Chapter meeting, are in agreement with our position.

In view of the fact that you have given so much publicity to the article by Mr. Michelsen, we hope that you will also print this letter and a full copy of our resolution.

Sincerely yours,

EDGAR BISSANTZ,

Secretary Southern California Chapter, American Institute of Architects.

Los Angeles, June 29, '38.

RESOLUTION:

Whereas, The President of The American Institute of Architects in his Address to the Seventieth Convention stated:

"It is protested here and there that The Institute is too selective and affects the airs of an Academy. There is a certain cruelty in that indictment.

The Institute has never closed its doors to an architect who was ready to meet a tolerant standard of capacity and willing to conform to a code of practice designed to protect him in his relation to the public and his fellows. To that extent only has The Institute of Architects been exclusive ever.

"It is true that numerically we make no convincing claim to nationally representative character. But our title has rested, and securely rested, upon other foundations, and few there are,

I believe, who have questioned the national scope of our authority.

"The Institute has been eager for an enlarged membership and has constantly stimulated the activity of the Chapters through whose direct agency alone that can be normally accomplished. Along the traditional avenues of increase a general drive is at this moment in process under the direction of the new Membership Committee. This effort, if energetically pursued, should fairly establish the number of those who conspicuously value our membership and, reasonably perhaps, the full stature of which the nature of The Institute is independently capable"; and

Whereas, The Southern California Chapter of The American Institute of Architects is in full agreement with the above statements of The President and deplors the fact that the Seventieth Convention, in its subsequent action concerning State Associations, did not accept the wise counsel of The President; and

Whereas, constant changes of the status of The Institute and of its membership only complicate and make confusing the true position of The Institute as an independent, self-respecting organization; and

Whereas, Chapters of The Institute may cooperate with State Associations on matters of common interest, which cooperation is in no way aided by a tenuous connection with them; and

Whereas, the Report of the Committee on State Organizations indicated that State Associations generally do not desire affiliation with The Institute, and that the few affiliated State Associations do not value such affiliation; and

Whereas, the stated membership of certain State Associations is open to question, because of the inclusion of non-dues-paying members; and

Whereas, the inclusion of "Members of State Association Members" in the published membership statistics of The Institute is a fiction having no validity nor significance for The Institute; and

Whereas, the increased stringency of licensing laws will automatically increase the proportionate number of architects who value and seek Institute Membership; and

Whereas, the influence of any organization depends upon the unity of purpose of its members, and not upon mere numbers; and

Whereas, an architect qualified for any acceptable form of "special" membership would, by the same token, be qualified for normal Institute Membership;

Therefore Be It Resolved:

1. That the Southern California Chapter of The American Institute of Architects re-affirms The President's fine statement as a sound expression of the true and proper position and scope of The Institute; and

2. That the further breaking down of membership qualifications in the impatient desire for increased numbers is unnecessary and reduces the character and desirability of Institute Membership; and

3. That if The Institute, as an independent organization, will pursue a progressive policy in the interest of architecture and the profession, it need not fear the interference of a third organization, nor seek to augment its nominal membership by connection with another organization; and

4. That we will continue our friendly cooperation with an independent State Association in this region and encourage our members to maintain their memberships in that Association; and

5. That we urge The Institute Board and all Members who value their memberships in The Institute to resist the "unification" movement to the end that further changes may be prevented, and that The Institute may return to its traditional, independent position described by The President.

Architects designing new homes under the Federal Housing Plan, will definitely insure their clients' perfect comfort by

INSULATING WITH CABOT'S QUILT

Placed in walls and ceilings Cabot's Quilt not only conserves heat and reduces fuel bills, but deadens sound. Furthermore it is vermin proof and fire resistive.

GUNN, CARLE & CO.

DISTRIBUTORS

20 Potrero Avenue
San Francisco

Underhill 5480

Oregon Architects

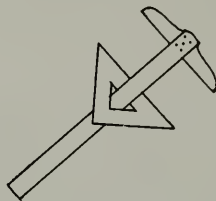

have found a dependable excellence of materials and service very much to their liking . . . available from N. Clark & Sons. As one of four Western distribution points, our sales representation is maintained by McCracken-Ripley Co., 2221 No. Albina Avenue in Portland; affording samples, information and estimates on N. Clark & Sons Architectural Terra Cotta and other clay products . . . all uniformly high quality, specified with confidence by members of the profession throughout the entire West for more than 50 years.

As this issue, in which this particular advertisement appears is devoted to Oregon architecture . . . we offer to Guest Editor Glenn Stanton, A.I.A. and all architects represented, our sincere congratulations . . . on this excellent portrayal of architecture in one of the West's most favored regions.

USE THESE CLAY MATERIALS
WHEREVER POSSIBLE

✓ *Ceramic Veneer*

*Architectural Terra Cotta
Unitile*

✓ *Glazed Hollow Wall Units*

✓ *Quarry Tile*

✓ *Terra Cotta Shower Base Units*

N • CLARK & SONS

116 NATOMA STREET

SAN FRANCISCO

PORTLAND

.

LOS ANGELES

.

SALT LAKE CITY

Carrier Engineers

SAFEGUARD AGAINST RUST

in new air-conditioning unit



The Carrier Portable Summer Air-Conditioner is completely automatic, needs only "plugging-in". It cools, dehumidifies, cleans and circulates the air. Made by Carrier Corporation, Syracuse, New York.

They select strong, non-rust EVERDUR METAL

One of the latest applications of Everdur Copper-Silicon Alloy has been made by the engineers of the Carrier Corporation in their new Portable Summer Air-Conditioner. This concern . . . world famous for its air-conditioning installations . . . has discovered that where dampness, condensation and corrosion constitute a problem, Everdur Metal is the logical answer.

Strong as steel, completely immune to rust and even more resistant to general corrosion than

copper, Everdur Metal is readily adaptable to all types of fabrication—including welding. Furthermore, its reasonable price makes Everdur doubly interesting wherever high strength and exceptional durability are determining factors in the selection of metal. Throughout the world, at innumerable tasks, Everdur Metal performs creditably. It is truly a modern material for modern engineering—available in all commercial forms. Our Technical Department is at your service.

38232



Exposed rear view of the Carrier Portable Summer Air-Conditioner shows the drip pan and internal casing of Everdur Metal. Tubes, "fins" and other parts are Copper or Brass. Result: rust eliminated, promoting efficiency, economy and durability.

Everdur Metal

THE AMERICAN BRASS COMPANY, General Offices: WATERBURY, CONNECTICUT
Offices and Agencies in Principal Cities • In Canada: ANACONDA AMERICAN BRASS LTD., New Toronto, Ont.



"EVERDUR" is a trade-mark of The American Brass Company, registered in the United States Patent Office.



Rambling design

HEAT PROBLEM SOLVED WITH GAS

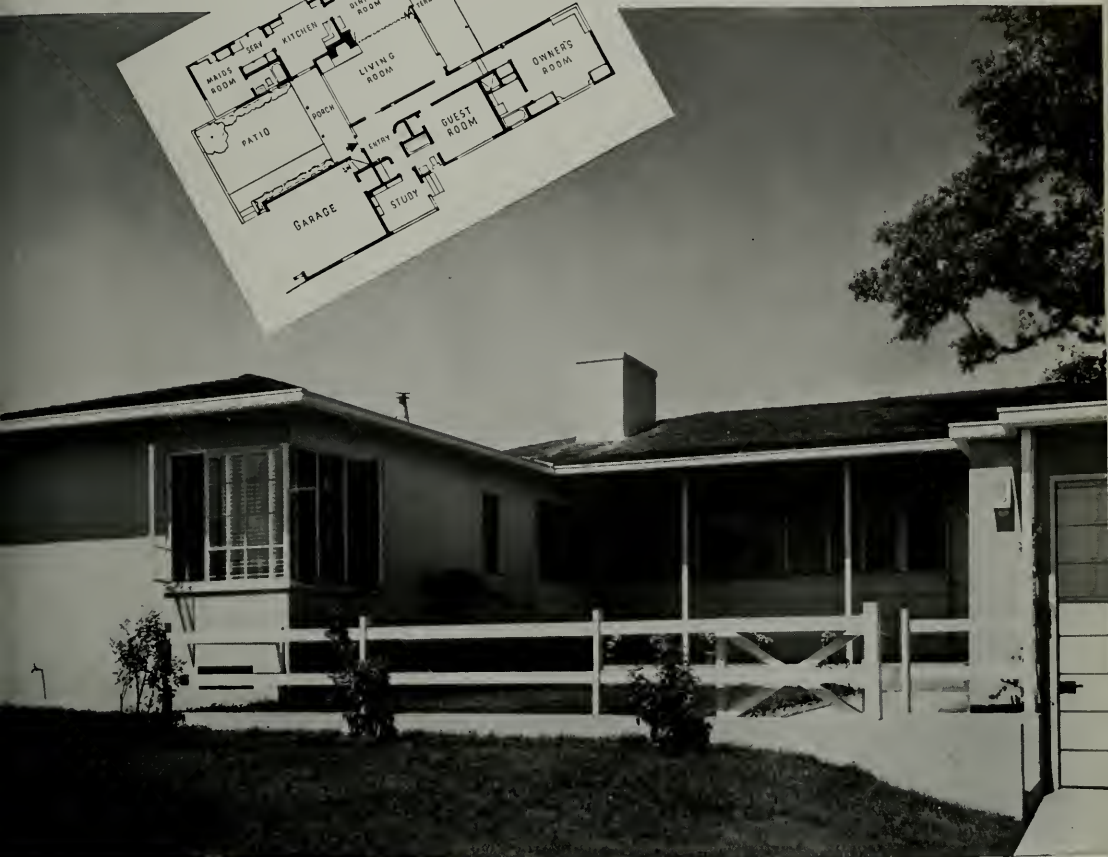
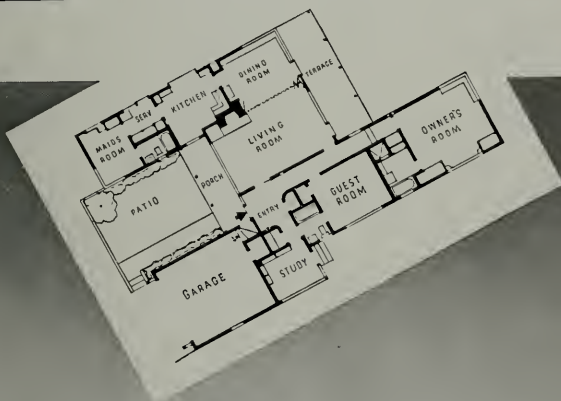

This small home was one of several California designs chosen in a nationwide contest, for publication in "House & Garden."

☆ Architects *Erle Webster* and *Adrian Wilson* achieved a happy combination in this interesting home for *Mr. and Mrs. Horace N. Gilbert, Pasadena*. ☆ The design affords a feeling of "openness," with privacy, on a 64-ft. lot. Yet, despite the separation of wings, and intervening patio, uniform heating is assured in all rooms by a forced-air, gas-fired heating unit, automatically controlled. ☆ There's a gas range, of course, and automatic gas water heater; even a gas lighter for wood fires in the fireplace. ☆ According to the architects, the owner originally considered other appliances, but "*changed to all-gas at a considerable saving in cost.*" This suggests a practical answer to your client who wants to put more money into other features without increasing his total investment: *quick, clean, dependable, economical gas appliances throughout.*

GAS

THE MODERN FUEL

HEATING - COOKING - HOT WATER - REFRIGERATION



Photo by W. Boychuk

ENTRANCE PORCH, HOUSE FOR MR. AND MRS. FRANK MEIER,
CLACKAMAS RIVER, OREGON
HOLLIS JOHNSTON AND HERMAN BROOKMAN, ARCHITECTS



Photo by Erven Jourdan

HOUSE FOR MR. LLOYD BABLER, PORTLAND, OREGON
HOLLIS JOHNSTON AND HERMAN BROOKMAN, ARCHITECTS

WHAT THE OREGON ARCHITECTS HAVE BEEN DOING

by GLENN STANTON, A. I. A., Guest Editor

NOW comes Oregon's own number, and since ponderous texts are preferably omitted when there are illustrations at hand, this article will have the merit of brevity at least, letting the cuts tell their own story.

The architectural background of the Pacific Northwest was particularly well covered by Charles H. Alden, F.A.I.A., when he presented the work of the Washington architects in the March issue of this periodical. As with Washington, we have no important historical precedent. The span from the log cabin to the present day was indeed remarkably brief.

There is one marked period, however, found chiefly in the Willamette Valley and that is the simple colonial style of the houses built from

about 1865 to 1880 by the immigrants who came over the old Oregon Trail from the Ohio Valley and eastern points. Quite a few show a feeling of the Greek Revival, others are finer in scale—a translation of style left in the old home states.

These early examples have influenced in a limited way, the domestic design of the architects, who have found in their simplicity and rugged character, a fair answer to the requirements of our climate.

As in our neighboring state to the north, Oregon is divided by the Cascades into the western quarter with a mild climate and the eastern three-quarters, with an arid and more severe climate. The earlier and characteristic

WELL STUDIED DETAIL IS FOUND IN MANY HOMES



Photo by Erven Jourdan

HOUSE FOR DR. MILLARD ROSENBLATT, PORTLAND, OREGON
HOLLIS JOHNSTON AND HERMAN BROOKMAN, ARCHITECTS



HOUSE FOR MRS. M. J. SAMMONS
PORTLAND, OREGON
Hollis Johnston and Herman Brookman, Architects

architecture of eastern Oregon is found in the simple ranch structures in the region around the Steens Mountains, which was settled by the Basque immigrants. Their buildings are low, and the walls of stone or adobe are often three feet in thickness. Unfortunately this simplicity and honesty of construction has not been followed in the present day building of the locality, where corrugated sheet iron and other abbreviations seem to suffice.

Oregon is more or less influenced from a financial and business standpoint by its largest city, Portland, which lies between the Willamette and the Columbia Rivers.

Our fresh water harbor brings ships from all important world-wide ports; and our nearness to the Orient has had a subtle effect on the feeling of much of our design.

Portland was settled by conservative New Englanders, and for better or for worse, we have followed a conservative pace. We have



Photo by Jourdan

GARDEN FRONT, HOUSE FOR DR. FRANK B. KISTNER, PORTLAND
WADE PIPES, ARCHITECT



ENTRANCE FRONT, RESIDENCE OF DR. RICHMOND WELLS,
PORTLAND, OREGON
WADE PIPES, ARCHITECT

Mr. Pipes, a native of Oregon, studied in England. His domestic work is distinguished in its adaptation to our climate and background.



HOUSE FOR IRVIN G. REINKE, PORTLAND, OREGON
ALBERT W. HILGERS, ARCHITECT

not known any great boom periods, nor have we experienced the opposite slumps as severely as faster growing centers have, in times past. One reason for this stability is that Portland is practically self-owned. We are not affected by the investments of great amounts of outside capital.

This short outline is given as a supplementary background. We all know that architecture is an expression of the times, and of the many complexities of the community's life and composition, so we will let the illustrations of our local work speak for themselves.

Our profession includes many men of distinguished taste and ability. Some of our colleagues are known nationally for their sensitive domestic design, while others have specialized in commercial, educational and public work.

About ninety per cent of Oregon's architects live in and about Portland and the natural community spirit has resulted in the group re-

solving into a very friendly association and one in which cooperation is becoming increasingly apparent.

Younger men are bringing with them a spirit of understanding, tolerance, and breadth of vision. Many of these men are recruited from the graduates of the University of Oregon, a school which is a leader in national educational training, and one that attracts students from the four corners of the country.

As is evident from even a brief perusal of the illustrations, our styles are varied. Many offices follow a traditional interpretation in a great deal of their work, yet are not aloof to the "functional" manner on occasion.

The illustrations have been confined chiefly to the work done since the passing of the days fondly known as "good-old"; that is since about 1929. And while we do not feel smug or self-satisfied, we believe that the future of Oregon architectural development is in thoughtful heads and good hands.

DESIGNED BY A NATIONALLY KNOWN ARCHITECT



Photo by Jourdan

ENTRANCE FRONT, RESIDENCE FOR WADE NEWBIGIN,
GREEN HILLS, PORTLAND, OREGON

HAROLD W. DOTY, ARCHITECT

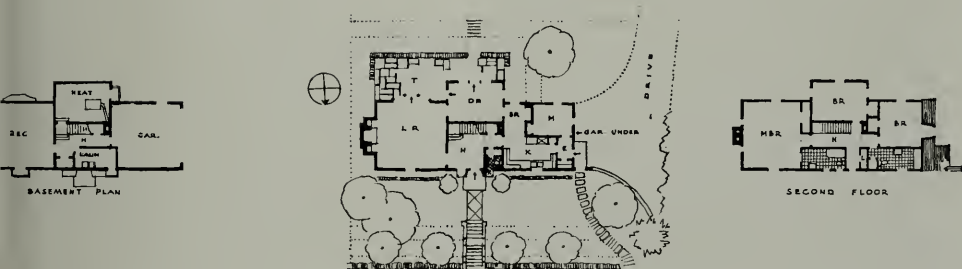

Mr. Doty's work has several times received national recognition. Although frequently founded on the English precedent, it is invariably characterized by distinct individuality.

PLANS OF RES.
MR. AND MRS. WADE NEWBIGIN
GREEN HILLS
HAROLD W. DOTY ARCHT.



Photo by Boychuk

RESIDENCE FOR F. W. CUTLER, LAKE OSWEGO, OREGON
MORGAN HARTFORD, ARCHITECT



DETAIL

THE Cutler residence is built on a peninsula of Lake Oswego. A high rock promontory was cut back, and grades established so the roof terrace connects with the rocky ridge and the lower terrace with the front of the house. Each room in the house has a view of the Lake; the master bed room has an outside door leading to the roof terrace, of concrete slab with brick paving, and a living porch adjacent to the living room is close to the lake. There is a large recreation room over the garage, and a boat house is provided with dressing rooms for swimmers.

The house is of brick veneer construction, painted white, with a roof stained blue. A forced warm air heating plant is placed in a utility room on the first floor.



RESIDENCE FOR FRANK KIERNAN, JR., WESTOVER TERRACES,
 PORTLAND, OREGON
 ROI L. MORIN, ARCHITECT

THE problem in designing the Kiernan residence was to set a dignified small house on an extremely narrow lot and yet take full advantage of the sunlight and view. The lot was only 54 feet wide at the sidewalk, but fanned back in a butterfly shape, so that it was 70 feet wide at the very edge of a steep back to the rear. This extra width allowed sufficient latitude to extend the long side of the living room to the view.

The plan was made very compact with every room opening off a small center hall, both upstairs and down, to make for a minimum of housekeeping. The house is of simple frame construction and the charm it possesses is due to meticulous detailing of all trim and millwork.

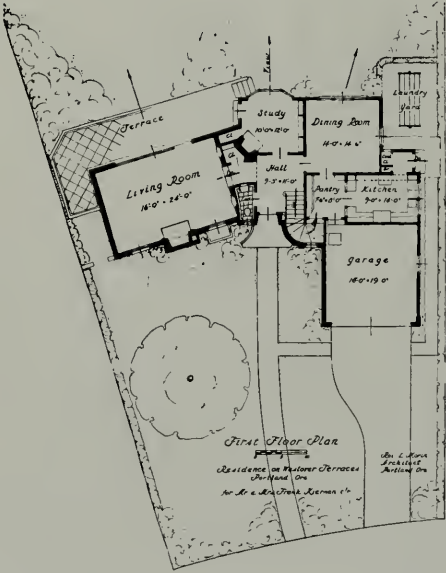

PLAN



CLINIC BUILDING FOR DR. E. H. McLEAN, OREGON CITY
TUCKER & WALLMANN, ARCHITECTS

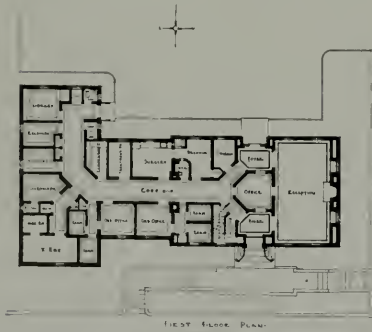
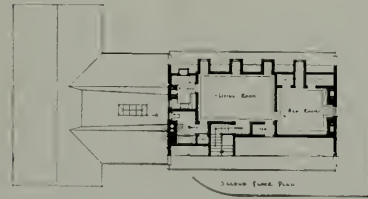

CLINIC BUILDING FOR DR. E. H. McLEAN
OREGON CITY - OREGON
TUCKER & WALLMANN - ARCHITECTS
PELLER DESIGN

PLANS

The clinic building is appropriately designed for its Oregon City background, the oldest city in the State. . . .

Many of the early buildings show the colonial influence of its founders. . . .

Across the street is the house of Dr. John McLoughlin, who came to Oregon from his post at Ft. Vancouver with the Hudson Bay Company.



Photo by Boychuk

HOUSE FOR SPENCER BIDDLE, VANCOUVER, WASHINGTON
 ERNEST F. TUCKER, ARCHITECT

THE residence of Mr. and Mrs. Spencer Biddle is located on the Evergreen Highway about seven miles East of Vancouver, Wash. In general, the site was well established with conifers, deciduous trees, an old orchard and lawns rolling down to the river bank. The house faces the river to the South with the entrance on the North side, giving all the major rooms a commanding view of the river. Although quite large, every attempt in its design was made to hold a simple, unpretentious relationship between house, garden, indoor and outdoor living the year round. Another consideration in planning the house, was the circulation of the various rooms, namely, family, entertaining, service and business.

The exterior is rough sawn boards and battens and shakes, painted white, with a black shingled roof. The detail is inspired from English and Colonial precedent. The house is of frame construction with a split indirect air-conditioned heating system.



HOUSE OF MR. & MRS. SPENCER BIDDLE
 VANCOUVER, WASHINGTON
 ERNEST F. TUCKER, ARCHITECT
 - PRESENT DESIGN



PLAN

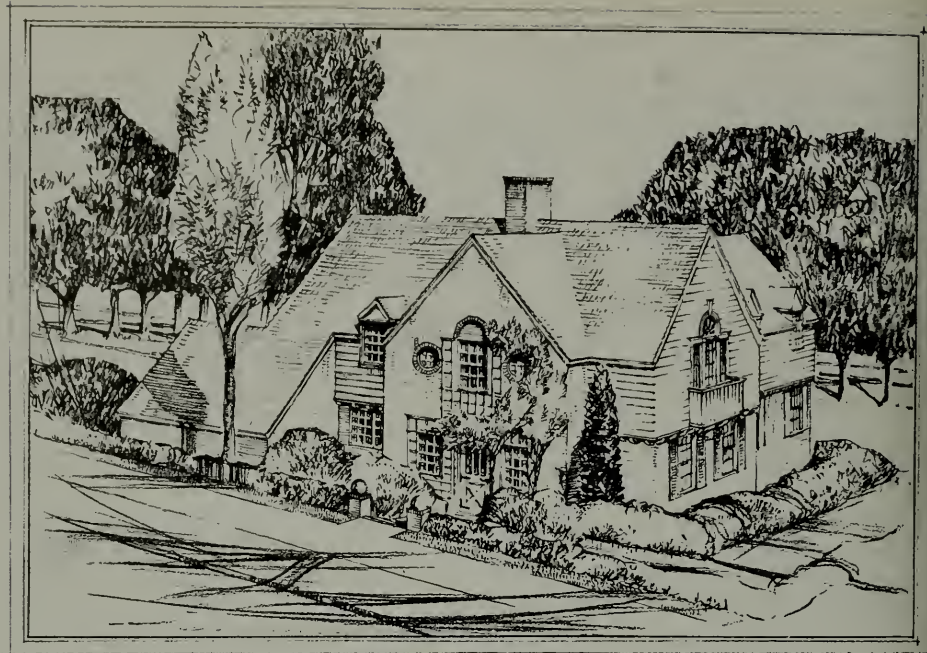

RESIDENCE FOR FREDERICK M. DE NEFFE, PORTLAND HEIGHTS, PORTLAND
ROI L. MORIN, ARCHITECT

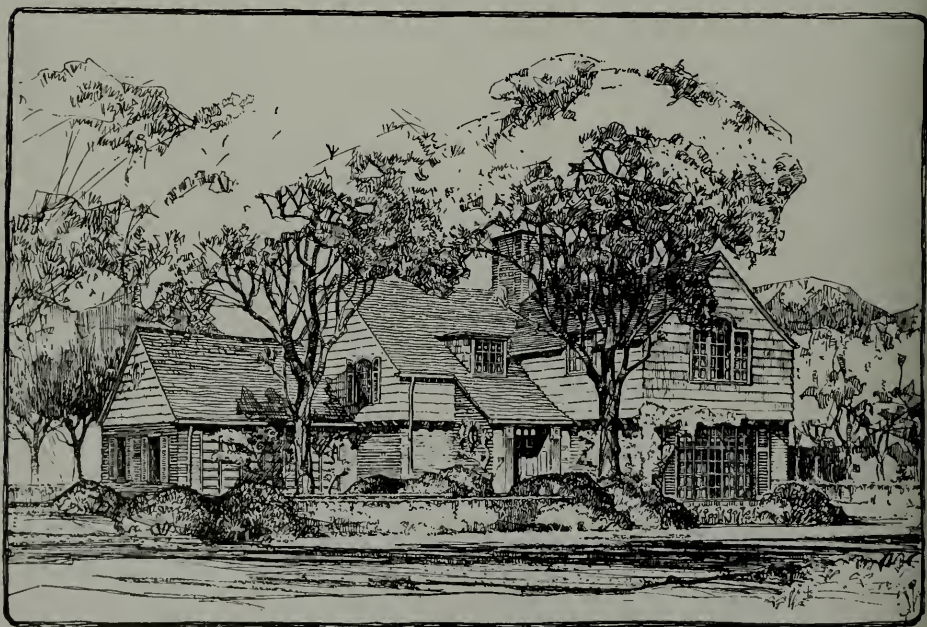

PERSPECTIVE, RESIDENCE FOR JAMES D. PLATT, "THE HIGHLANDS," OREGON
ROI L. MORIN, ARCHITECT



Photo by Jourdan

TOWN CLUB, PORTLAND, OREGON
JOHNSON, WALLWORK & DUKEHART, ARCHITECTS



RESIDENCE FOR DR. AND MRS. PAUL BAILEY, PORTLAND
JOHNSON, WALLWORK & DUKEHART, ARCHITECTS



ARCHITECT'S SKETCH, RESIDENCE FOR MR. AND MRS. ROBERT ARNESON,
LAKE OSWEGO
GLENN STANTON, ARCHITECT



Photo by Boychuk

RESIDENCE FOR MR. AND MRS. ROBERT ARNESON, LAKE OSWEGO, OREGON
GLENN STANTON, ARCHITECT

WIDE BALUSTRADED STEPS GIVE PLEASING ENTRANCE APPROACH



ENTRANCE FRONT, RESIDENCE FOR MR. AND MRS. ROBERT ARNESON,
LAKE OSWEGO, OREGON

GLENN STANTON, ARCHITECT

DISTINGUISHED FOR SOUNDNESS AND UNITY



GARDEN OF
MRS. T. B. WILCOX,
PORTLAND, OREGON

FLORENCE HOLMES GERKE,
WALTER GERKE,
LANDSCAPE ARCHITECTS

Photo by Walter F. Haver, Jr.

GARDEN OF
MRS. JOHN B. YEON,
PORTLAND, OREGON

FLORENCE HOLMES GERKE,
WALTER GERKE,
LANDSCAPE ARCHITECTS

Photo by Geo. A. Corley



NO, THIS IS NOT THE ALPS IN SWITZERLAND



GENERAL VIEW, TIMBERLINE LODGE, MT. HOOD, OREGON
U. S. FOREST SERVICE, ARCHITECTS
GILBERT STANLEY UNDERWOOD CO., ASSOCIATE ARCHITECTS

MT. HOOD TIMBERLINE LODGE IN THE MT. HOOD NATIONAL FOREST WAS BUILT WITH W.P.A. LABOR AT AN APPROXIMATE COST OF \$1,000,000. ELEVATION IS 6,000 FEET. THERE ARE 250 GUEST ROOMS IN ADDITION TO SPACIOUS LOUNGE, DINING ROOM, COFFEE SHOP, SKI LOUNGE, BALCONY AND LARGE PUBLIC SPACE. . . . 104,000 SQ. FT. OF FIR-TEX USED.



CORNER OF MAIN FLOOR LOUNGE,
TIMBERLINE LODGE, MT. HOOD
U. S. Forest Service, Architects
Gilbert Stanley Underwood Co., Associate Architects

A WELL STUDIED TREATMENT OF BRICK AND TERRA COTTA

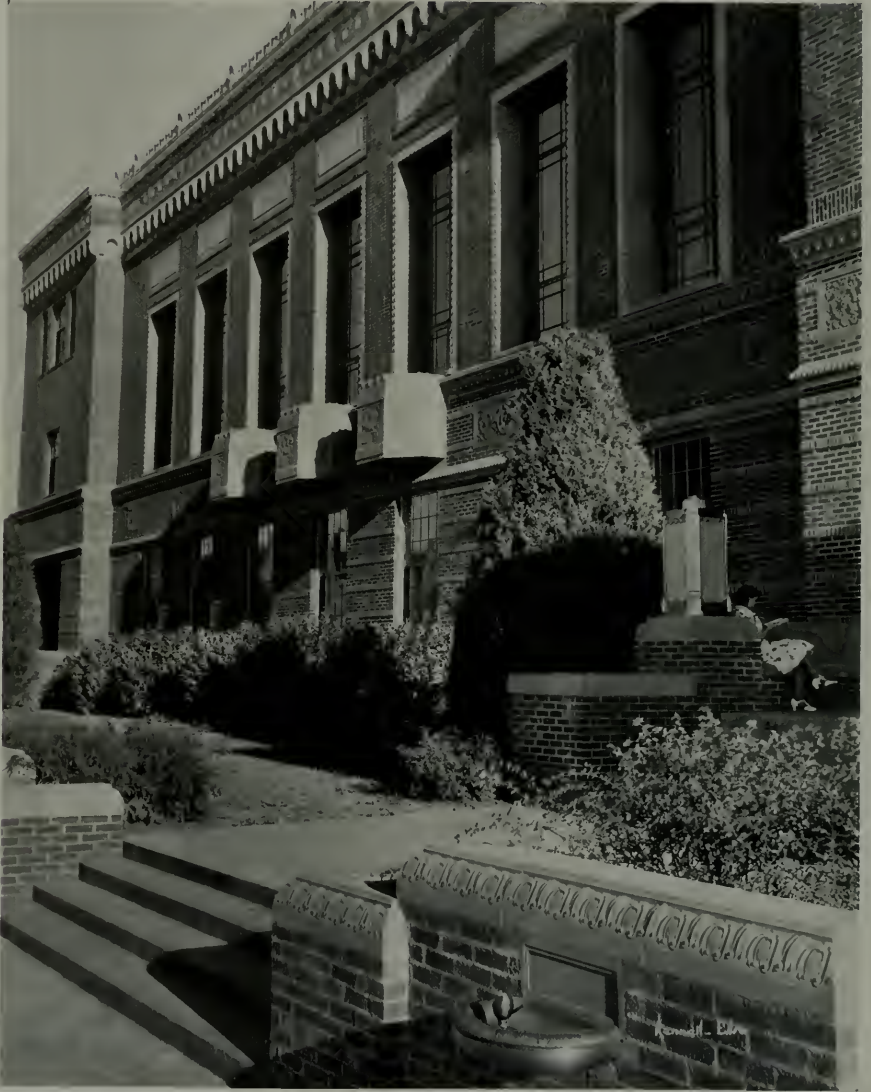

Roof insulation, "Fir-Tex"

LIBRARY, UNIVERSITY OF OREGON, EUGENE, OREGON
LAWRENCE, HOLFORD AND ALLYN, ARCHITECTS

THE BUILDING FITS PERFECTLY INTO THE LANDSCAPE



SKETCH OF FIRST UNIT, TUBERCULOSIS HOSPITAL, PORTLAND, OREGON
LAWRENCE, HOLFORD AND ALLYN, ARCHITECTS

ALTERATION FOR
MILTON L. GUMBERT,
PORTLAND, OREGON

Lawrence, Holford &
Allyn, Architects

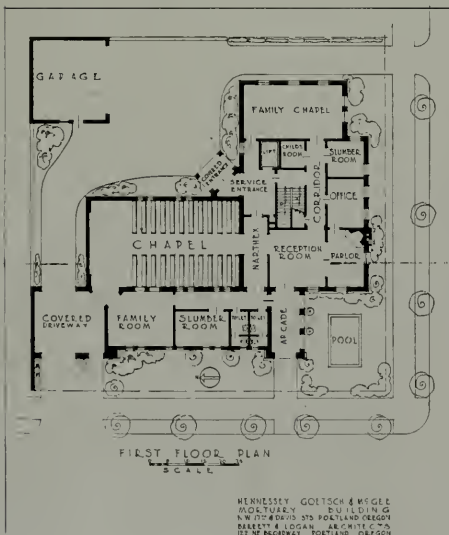

Photo by Columbia Studio



MORTUARY BUILDING FOR HENNESSEY, GOETSCH & MCGEE,
PORTLAND, OREGON

BARRETT AND LOGAN, ARCHITECTS



PLAN

BUILDING was finished in January, 1936, at a cost of \$38,000. The exterior finish is light buff brick with native bush-hammered-granite finish. The roof is Granada Clay Tile. . . .

An electric heating plant heats the building, which is partly air conditioned. . . .

The interior of first floor and basement is finished with Fibre Board Decorative Nu-Wood walls and ceilings. The family chapel has open truss ceiling with art-glass windows. . . .



CITY HALL, CANBY, OREGON
JONES AND MARSH, ARCHITECTS



Photo by Kennell Ellis

KLAMATH FALLS ARMORY, KLAMATH FALLS, OREGON
HOWARD PERRIN, ARCHITECT

TWO WELL DESIGNED COMMERCIAL BUILDINGS



Roof insulation, "Fir-TeX"

ENTRANCE DETAIL,
JANTZEN KNITTING MILLS,
PORTLAND, OREGON

Richard Sundeleaf
Architect

WAREHOUSE,
JANTZEN KNITTING MILLS,
PORTLAND, OREGON

Richard Sundeleaf,
Architect





GARDEN VIEW BETWEEN NURSES' HOMES, GOOD SAMARITAN HOSPITAL,
PORTLAND, OREGON
SUTTON, WHITNEY & AANDAHL, ARCHITECTS

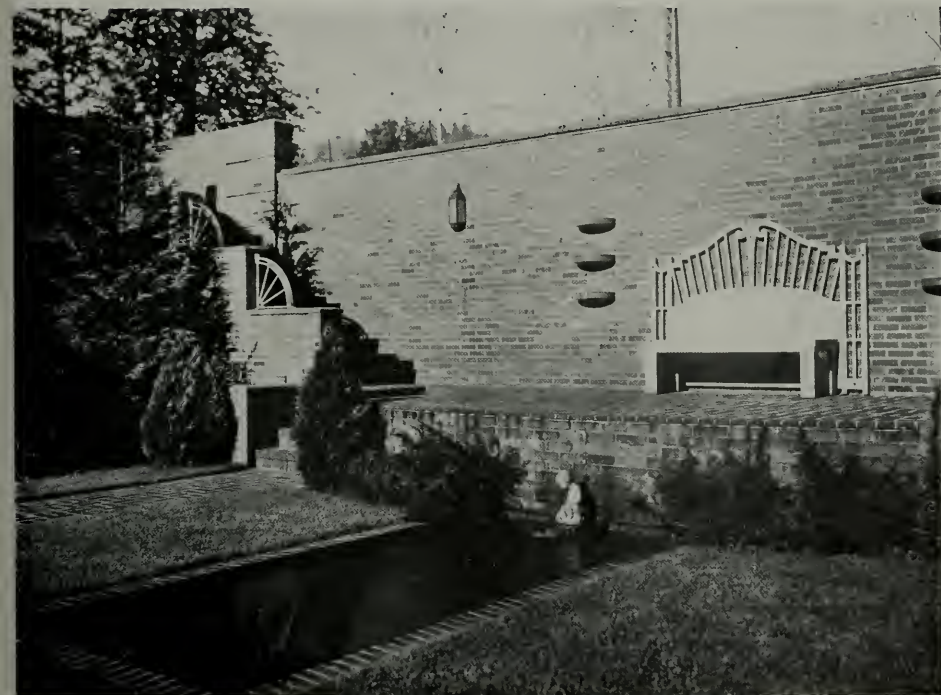

DETAIL



SAINT **G**EORGE'S **E**PISCOPAL CHURCH ROSEBURG OREGON

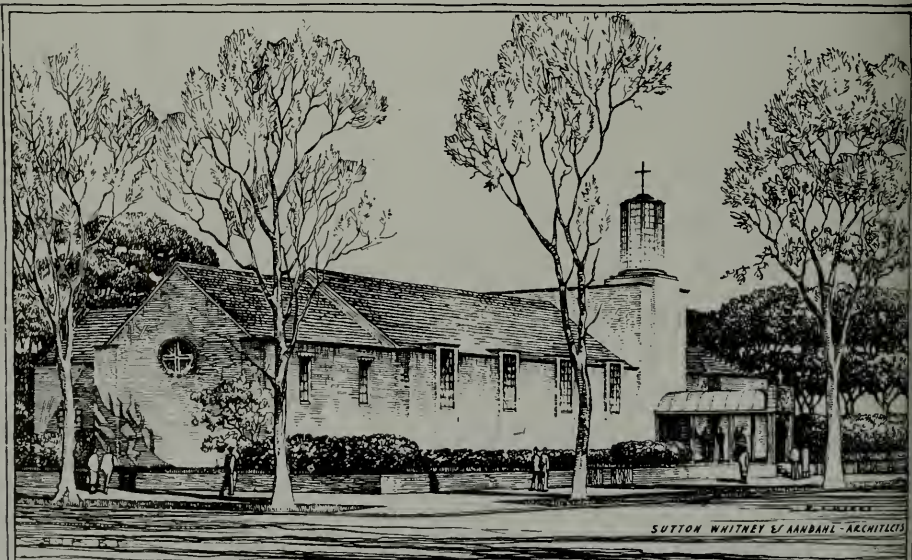

SAINT **M**ARY'S **E**PISCOPAL CHURCH EUGENE OREGON



FRONT ELEVATION, FINLEY'S MORTUARY, PORTLAND, OREGON
A. E. DOYLE AND ASSOCIATE, ARCHITECTS

This building awarded Honorable Mention at the National Exhibition of the New York Architectural League in April. Also named by the A. I. A. as one of the best one hundred buildings done in America during the past 20 years.

TWO BUILDINGS THAT HAVE WON NATIONAL RECOGNITION



SIDE ELEVATION, FINLEY'S MORTUARY,
PORTLAND, OREGON

A. E. DOYLE AND ASSOCIATE, ARCHITECTS

Elimination of superfluous detail and constant crispness of design mark this firm's work. . . .

Their interpretation of the traditional as well as their functional style is always modern, and distinguished for its freshness.

DETAIL OF ENTRANCE, ART MUSEUM,
PORTLAND, OREGON

A. E. Doyle and Associate, Architects

Selected by the A. I. A. as one of the best 100 buildings done in America in the past 20 years.





Exterior of Willamina brick

LIBRARY, WILLAMETTE UNIVERSITY, SALEM, OREGON
A. E. DOYLE & ASSOCIATE, ARCHITECTS



Photo
Erven Jourdan

FIFTH AVENUE SHOP, PORTLAND, OREGON
A. E. DOYLE & ASSOCIATE, ARCHITECTS



ALL SAINT'S SCHOOL, PORTLAND, OREGON
FRANCIS B. JACOBBERGER, ARCHITECT

BELOW—END BAY IRVINGTON SCHOOL,
PORTLAND, OREGON
GEO. H. JONES, ARCHITECT



SENIOR HIGH SCHOOL, SALEM, OREGON
(See opposite page)

Pupil capacity: 1800.
Cost of building and equipment: \$700,000.00.
Cost per cubic foot: 20c.
Cost per pupil: \$389.00.

Class rooms	32
Commercial department	7
Number of laboratory rooms	14
Library reading room	1
Librarian's office	1
Librarian's workroom	1
Study rooms (auditorium)	
Commercial Art	2
Fine Arts	}
Public speaking (auditorium)	
Music room	1
Offices	4
Book storage	1
Matron	}
Nurse	
Clinic	
Girls' rest	
Teachers	5

SIZE OF LARGER ROOMS:

Auditorium	88' x 100', Capacity 1750
Cafeteria	78' x 82' (below auditorium)
Gymnasium	76'-6" x 122'. Seating capacity 780
Shops building containing 5 class rooms, 4 shops and 1 office.	



SENIOR HIGH SCHOOL, SALEM, OREGON
KNIGHTON & HOWELL, ARCHITECTS

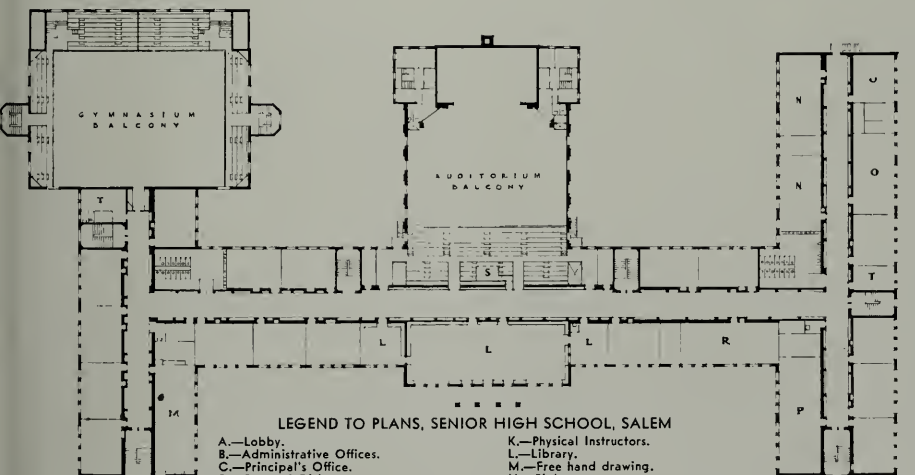
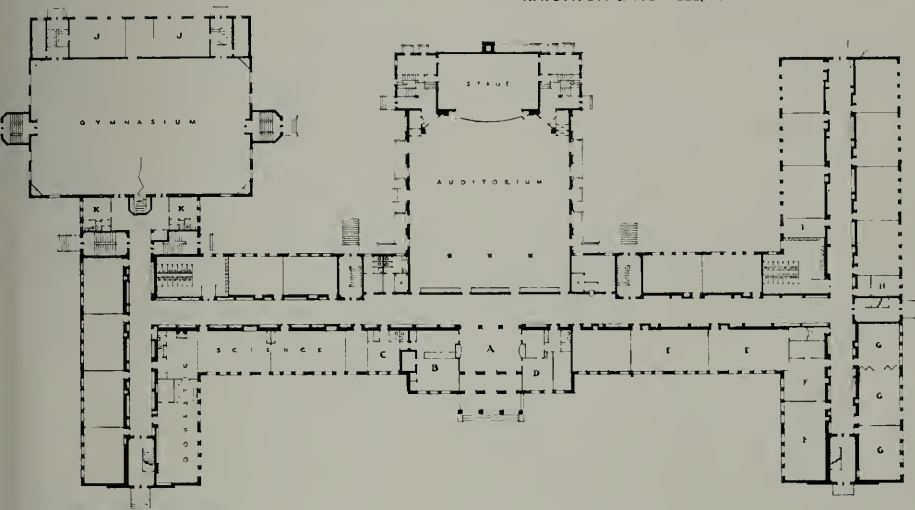

LEGEND TO PLANS, SENIOR HIGH SCHOOL, SALEM

- | | |
|-------------------------------------|--------------------------|
| A.—Lobby. | K.—Physical Instructors. |
| B.—Administrative Offices. | L.—Library. |
| C.—Principal's Office. | M.—Free hand drawing. |
| D.—Dean of Girls. | N.—Biology. |
| E.—Bookkeeping. | O.—Chemistry. |
| F.—Stenography and Office Training. | P.—Physics. |
| G.—Typing. | R.—General Science. |
| H.—Boys' Advisor. | S.—Projection room. |
| I.—Student activities. | T.—Teachers. |
| J.—Corrective rooms. | |

JEWELRY STORE FOR
STONE-MARGULIS, PORTLAND,
OREGON

Harry A. Herzog,
Architect

Photo by Maurice Hodge



ALTERATION, STORE FOR BURNETT BROS., PORTLAND, OREGON
HARRY A. HERZOG, ARCHITECT



ALTERATION, DEADY BUILDING, PORTLAND, OREGON
HARRY A. HERZOG, ARCHITECT

REGENT APARTMENTS,
PORTLAND, OREGON

Harry A. Herzog,
Architect





KLAMATH FALLS BRANCH, U. S. NATIONAL BANK OF PORTLAND
SUTTON, WHITNEY AND AANDAHL, ARCHITECTS

THROUGH A MONOCLE

London Architect Surveys United States—Its Muffins and its Architecture

By HARRY SANDERS, JR., B. Arch.

"YOUR muffins are our scones; our hot scones are your hot biscuits; your crackers are our biscuits; our sweet biscuits are your cookies; your griddle cakes are our sweet cakes and muffins . . ."

C. Hugh Crawford, M.A., R.I.B.A., of London and Belfast, sat in the lobby of his hotel one evening during his month-of-June visit to San Francisco and discussed multiple phases of the United States—culinary as well as architectural.

"But that is one of the many reasons I wanted to spend almost a year in your magnificent and refreshing country," he went on. "The average European thinks of 'The States' as one vast country without contrasts and comes over here to see the 'highspots' such as New York, Washington, Niagara Falls, San Francisco and the Grand Canyon. Yet I was determined to spend enough time here to learn to know—not just see—the real people of your country and to learn something of the customs of your varied localities. I came here with few pre-conceived ideas; I came here to absorb America and its architecture, not to compare it with premonitions."

Mr. Crawford, a graduate of Cambridge University and of the Architectural Association School, London, and now a practicing residential architect in London, has not found as yet what he expects to remember as the typical American city. He admits disappointment in finding romantic details atop New York's skyscrapers, "which had massed so beautifully when seen from the deck of the 'Queen Mary'." He found Boston "a charming city whose Georgian houses are comparable to Park Lane, London." In Philadelphia, where he had expected to see the best old architecture, he was surprised to find also some of the best modern work. He admired only the city plan and the railroad sta-

tion's location in Washington, "a city of too great contrasts and a city without feeling." He credits Savannah and Charleston with having the best city plans in the country. He planned to stay one week in New Orleans but spent seven weeks there and in Natchez and the Teche country. He admired Texas' cities for "their freshness of outlook"; New Mexico "because its strange medieval customs are not a revival but a survival"; Los Angeles "for its unlimited possibilities in the future," and . . .

"Well, San Francisco!" he exclaimed. "It not only has character but it is character-full! Its position on hills—and on the bay—reminds one of Oslo, and the Golden Gate is similar to the entrance to a Norwegian fjord; the flat-roofed white structures of Telegraph Hill are reminiscent of Palestine, and yet the downtown shopping section quite naturally possesses the atmosphere of the Orient. And furthermore, the lovely scenery of Marin County is like that of our own Dorset hills!"

"As for the architecture in San Francisco," continued Mr. Crawford, "there seems to be vigor and freshness in the more recent work. And the architects of the city have realized their responsibilities in building to take full advantage of the climate and of the views. Here—because of stepped terraces, decks and view windows—the ordinary house becomes an interesting solution. And your two bridges, together with New York's Tri-borough bridge, impress me as being the finest examples of modern architecture in the United States."

But C. Hugh Crawford has not found the typical American city.

"For, you see," he explained, "the English mind is too often influenced by your Hollywood films—gangsters and drug stores and what not!

"I have, of course, found your skyscrapers

most typical of every city and most foreign to me," he began when I asked him—perhaps unfairly so—to speak frankly about the United States compositely. "But it seems frightfully illogical to find a Greek colonnade or a Gothic tower or a chateau-pitched roof used to ornament a structure with a purpose so straightforwardly functional. Your means of transportation, your radios in cars, your speed in your every move—all are so modern that it seems bad to think of your buildings as 'What style?' However, I am pleased to see that your most recent skyscrapers are evading romanticism.

"As for your city planning and parks, I commend you for the remarkable tidiness of these public areas, and your filling stations are far less offensive than those of England. Your highways are splendid, but I can not help but ask why your railroad stations are often so far removed from the hearts of the cities. I have seen some cities where railroad tracks cross thoroughfares and where the stations, because of their isolation, lose their value as a gate to the city. Likewise, I have been impressed with the immediate change from your smartest streets to your worst slums and with the slight progress in slum clearance.

"As for the recent residential work in 'The States,' again I have found a great mixture of the styles. This surprises me for there are so many parts of the country, so free from a past, where it would be refreshing to trade on the present-day rather than to attempt to re-create the yesterday. But your residential neighborhoods have a far better feeling of openness and oneness than they have in England. Each home here seems to contribute to the general interest and welfare of the community, whereas at home each small plot of ground is isolated by means of walls and hedges.

"Another thing I can not understand," the London architect continued, "is why some of you Americans come to Europe and clamor aloud that there is no old work worthy of mention in the United States. You have many places in this country that are not appreciated as yet. Moreover, it is a fascinating study to follow the

development of the early settlers. But I have found many examples of fictitious valuations of historic spots. For instance, I consider the bear and bull ring in Monterey one of the most interesting places in the country, but it is seldom mentioned and is decaying while much is made over a house where Robert Louis Stevenson spent but a short time."

Mr. Crawford spoke of recent architectural problems with which he had been confronted in London and spoke understandingly of modern architecture in the various European cities.

"In Europe we are trying to build in a logical, functional manner. We try to consider the surroundings so as to avoid terrific contrasts and yet bring about the sensible solution; and if the solution to the architectural problem turns out to be Modern or Regency, let it come! There is great danger of a "Modern" style being born; yet regional characteristics are being developed and will develop to a much greater extent.

"As you know, England was one of the last countries in Europe to take an interest in modern work, but today I believe we are as far advanced as any country. The feeling in the country seems to be that extreme Modern and Regency have a common bond—that of being the architectures developed in times of similar economic stresses when simplicity and plainness were requisites. The two types are used together often and have brought about some happy solutions."

From San Francisco Mr. Crawford expected to travel East via Salt Lake City, Denver and Chicago. He will spend the rest of the summer in New England and Canada and before sailing in the late fall will visit Virginia and re-visit New Orleans.

Before his departure I offered to drive him once more to the Coit Tower on Telegraph Hill. I explained that the battery of my car was "weak" and that we might have trouble in starting the car.

"Oh," said he, "I do hope we shall not have to swing it!"

RECENT TRENDS IN LIBRARY ARCHITECTURE

By CARL B. RODEN*

"THE public library is one of the most highly developed types of buildings to be found in American architectural practice. By careful study of the problems it presents, primarily by librarians and secondarily by architects, its requirements and the best means for meeting them have been more completely worked out and standardized than those of any other type of edifice except the modern office building. Taken as a whole, the libraries of the United States, large and small, represent American architecture well-nigh at its best."

These words form the opening paragraph of a chapter on the Essentials of Library Planning in a useful and well illustrated manual issued in 1915 by Snead and Company, one of the leading manufacturers of library bookstacks. Their author was A. D. F. Hamlin, late professor of the history of architecture at Columbia, and at that time consultant to the building committee of the Brooklyn Public Library. The chapter embodies a summary of his observations resulting from a study of library architecture, both American and European, made for the Brooklyn committee, and contains many counsels and conclusions still sound and practical. It contains, also, a definition of libraries as "devices for bringing books and readers together," about as shrewd and pregnant a characterization of these institutions as was ever formulated.

But the Brooklyn building on which Dr. Hamlin collaborated was never built, and is only now, after many postponements, once again approaching the construction stage, under new architects and with new plans which show considerable variation from the monumental project developed nearly thirty years ago. Sketches thus far available indicate not only a new and appropriately modern rendering of the exterior, but even more interesting changes in the

arrangement and allocation of interior spaces, and these changes would doubtless have been still more radical but for the hampering compulsion imposed upon the architects of utilizing in part the old foundations, laid in Prospect Park some time before 1910.

Significant of the progress made in library planning since Dr. Hamlin wrote, are the elimination of the lofty flight of external steps, as well as of the "grand staircase" on the ground floor, and a considerable shortening of the space to be traversed from the front door to the rooms where books and readers are to be brought together—all features of a new approach to those problems, which, in his view, had been largely solved and standardized in 1915. The truth is that the library plan, particularly that of the public library, is, happily, far from standardization—farther now than it was a quarter century ago—and that it will scarcely reach that definite state so long as the functions and objectives of the public library continue to expand and librarians retain the enterprise to develop new service ideals and the ingenuity to realize them.

Meanwhile the current trend in library planning and its development to date are exemplified in four public library buildings—Cleveland, Los Angeles, Baltimore and Rochester, N. Y.—all built within the past ten or a dozen years, and each representing the progressive development and application of a group of ideas that sets it apart from its predecessors. . . .

In brief, the new library plan may be characterized as the embodiment of a conscious effort on the part of librarians to abandon the traditional conception of the public library as an "institution," which must be housed in a building monumental in outline but which, too often, proves to be overwhelming rather than impressive, forbidding than inviting, in effect. Sec-

*Bulletin, Illinois Society of Architects.

only, the present-day librarian knows, or thinks he knows, that the shortest distance and the straightest line between the reader, once he has passed the library portals, and the books provided for his use are ends to be achieved at all costs—even at the cost of majestic stairways and approaches without, and dazzling corridors and bewildering angles within.

Imbued with such aspirations, those of our colleagues to whom has recently been accorded the rare privilege of planning a new library building, have sought to give expression in the buildings themselves to that spirit of service and of expansive hospitality which animates their institutions; to bring the library and its wares to the attention of the citizen first of all through the inviting and friendly aspects of facade, entrance, and windows, and thus to enlist these architectural elements in its never-ending campaign for the abatement of those hazards, both mental and physical, that seem still to intervene between it and a large part of the public that it seeks to serve. And within the walls the same inviting effect is sought and largely achieved by the disposal of the principal rooms in the most prominent locations, wherever possible on the street level floor, directly accessible as soon as one enters the building. The public library has come out into the open and, in coming into the open, has gone a long way toward coming into its own.

Four Outstanding Libraries

The first of the four buildings mentioned as illustrating the new direction is that of the Cleveland Public Library, completed in 1925. Designed as a unit in a civic center plan, the Cleveland building conforms in general to the pattern of the group and is perhaps less typical of the modern library plan than its successors. Internally, however, it sets the pace in the new direction by introducing the so-called departmental system under which, in place of a large central circulation hall and central reading room where books of all classes are issued, the contents of the library are divided among a series of connected rooms around the perimeter of the building, each devoted to a single literary class or group of allied classes, and each

containing all of the essential books in its class. An inner belt of small stack rooms, lighted from a central court, is installed immediately adjacent to, and accessible from, these rooms, and takes the place of the huge bookstacks of the older libraries in which all of the books are shelved and from which they must be drawn by requisition and delivered by messenger.

In Los Angeles, erected in 1926, the architect was instructed that the building must "express warmth, hospitality, attractiveness and invitation," a combination that was more or less completely realized in the picturesque composition in concrete and stucco, the general architectural character of which, as explained by the architect himself, "cannot be classified at this time." Here, too, the departmental plan was adopted, with some modifications imposed by the irregular contour of the building, but, on the whole, with less practical success and without the effect of simplicity and cohesion apparent in the severely rectangular Cleveland structure.

The most distinguished exemplar of the modern library plan, and one that will not soon be surpassed, is the beautiful Enoch Pratt Free Library of Baltimore, opened in 1932, whose suave lines, dignified facade, block-long row of beckoning windows and beautiful portal are eloquent with gracious hospitality. The building is entered on its main service floor at sidewalk level. The same spirit of welcome and good will pervades the interior, which comprises a great central hall surrounded by the public rooms, each devoted to a single field of knowledge, but, unlike Cleveland and Los Angeles, all open and directly visible from the central hall which is in effect a spacious lobby rising to a two-story height and surmounted by a decorative skylight. Twelve large windows at pedestrian level not only transmit an abundance of daylight but serve in their lower sections for window displays in the mercantile manner, definitely planned to demonstrate the relation of books to every community interest. The only evidence of formality and control is in the two service desks for the performance of the necessary but simple routines incidental to the lending of books, and these desks are discreetly placed on either

side of the entrance where they meet the visitor's eye only as he turns to leave the building.

The new Rochester public library, completed in 1936, pays to Baltimore in generous measure that tribute which is known as the sincerest form of flattery, particularly in its interior which comprises the sky-lighted central hall with open subject-departments ranged around it. Externally, however, the Rochester building presents a somewhat sterner front and more of those "institutional" aspects that the new trend seeks so sedulously to avoid. In both Baltimore and Rochester, ample storage stacks are provided in basements directly beneath the main floor with access from the several departments.

Thus it appears that some, if not much, water has passed under the bridge that spans the small stream called Library Architecture, since Prof. Hamlin wrote in 1915. It is a small stream, indeed, and one that few in the architectural profession have found it either interesting or profitable to turn to for the occasional flotsam borne on its feeble current. But it is still a flowing stream, in no immediate danger of disappearing altogether into the ground, and one which contrives, now and again, to cut out new channels for itself leading into new and virgin fields. To speculate upon the future course of its meanderings is a favorite pastime of librarians, and since, as we read with some satisfaction Dr. Hamlin's opening paragraph, such progress as has been made in working out the problems of library architecture is due "primarily to librarians and secondarily to architects," it would seem that their speculations had been carried on to some purpose and should be continued, if only to postpone the day when the "last word" on library building and the function of the public library shall be spoken.

Library of the Future

As one more speculation the following is, therefore, submitted, namely, that the next turn in the tide will be towards smaller library buildings with less space for the storage of books, and that the public library of the future will gradually give over the policy to which, since time immemorial, it has been committed, of zealously hoarding great numbers of books that have no longer a bearing upon the wants of its patrons or are of such infrequent use as to entail a cost in space and care out of all ratio to their intrinsic worth. For such books a central storehouse will be provided, probably to serve a wide area, whence they may be withdrawn with reasonable expedition in the rare event of their need, and to which they may be as expeditiously returned.

This is not a new notion. The memory still lingers of a similar proposal at a library conference some thirty years ago, and the shrill screams of protest with which it was greeted. But the fact that all the books worth keeping in all the world can still with ease be counted in six figures—and probably in five—will one day work its way into library administration, and the librarian of the future, when his time comes to build a new library, will resolutely protect himself against his occupational vice of book hoarding by omitting or greatly reducing the conventional "storage stack" with a capacity of astronomical figures, and will, with book collections kept well balanced and alive through rigid and continuous weeding, succeed in amply serving, at much lower cost of time and money, space and peace of mind, the most exacting and inclusive wants of his constituency. This, as has been said, is not a new notion, and was properly scorned in its time. But it has latterly been advanced again by some of our forward-looking colleagues and is likely to meet with increasingly favorable consideration.

WORLD'S FAIR BUILDERS—Wm. Gladstone Merchant

NEW DESIGNS for new fields, things never done before, fantastic enterprises in which utility blends with symbolism to the point where they become practical enough so that they might some day happen—these are the favorite architectural pastures of William Gladstone Merchant.

Long back in 1933 his roving chalk sketched the firm outlines of Treasure Island, between two bridges that weren't there yet. He was a member then of the Advisory Committee of the Bridge Celebration Founding Committee, a collection of citizens who were indulging in pipe-dreams. Merchant had some pipe-dreams of his own, and put a lot of them on paper in big chalk sketches; one of them is Treasure Island today.

Others of Bill Merchant's chalk sketches are out there on the pipe-dream island, notably the East Towers at the margin of the Pacific Area; the Pacific House itself, standing as a theme building in the center of the lagoon with great elliptical windows facing each point of the compass, and a supervisory finger in the Pacific Basin itself. This latter is a dream of a project in itself—whole squads of pavilions dedicated to separate foreign nations, each one faithful architecturally to the traditions of its sponsor country.

It was chalk that drew Bill Merchant into architecture, with no double meaning intended. He was born in Sonoma County, near Healdsburg, where anybody with a hammer, nails and some lumber was a qualified architect, and he looked at the life of a cartoonist with considerable interest for a time. Then it came home to him that chalk-marks in the architectural field were much more promising, if a man wanted to sketch something that would last a while, and his self-expression veered that way.



WM. GLADSTONE MERCHANT
AND HIS PROPHETIC CHALK

So Bill Merchant literally grew up in an office, starting with John Galen Howard and receiving an early training that stuck. Then he helped Bernard Maybeck for three solid years on the Palace of Fine Arts for the 1915 World's Fair, and has been associated with him, more or less, ever since. For many years, concurrently, he was associated with the late George W. Kelham, working on many downtown buildings in San Francisco, particularly the Medico-Dental Building.

In 1930 Bill Merchant set up an independent office, containing his close identification with Mr. Maybeck. Recently he has been consultant for the Recreation Department, City of San

PARABLE ON STYLE

By Irving F. Morrow

San Francisco, and he laid out the forty-acre Crocker Amazon tract as a playground, elaborately compact. The Woodlawn mausoleum reconstruction is a job he remembers, but he likes better to do something that hasn't been done before.

That's why he was suited when the Bridge Celebration Founding Committee grew into the 1939 Golden Gate International Exposition, with Bill Merchant on the Architectural Commission and the Pacific Basin in his hands. The Pacific Basin expresses the theme of the Exposition, and its importance inspired Bill Merchant to make more chalk sketches than could possibly be jammed into the construction budget, for it was something that hadn't been done before.

It's being done now, with architectural unity and symbolism that will penetrate the public consciousness. It is for Bill Merchant to see the golden finials, cornices and doorways of Siam harmonize with the sculptures of Cambodia, and that everything falls into the spirit of his East Indian temple-towers without losing native individuality.

The lagoon, with its fringe of colorful pavilions and its regatta of sampans, catamarans and bumboats, won't last. Neither will the exotic landscaping around it, for such things don't belong on an airport. But the congress of Pacific and world nations—dozens of them, discussing matters of mutual importance in the Hall of Pacific Relations, and rubbing elbows on Treasure Island—can easily bring Bill Merchant's chalk sketches the stability he likes them to have. Political stability, which is even more vital than architectural stability.

When Le Roy Sylvester Tuttle thought of building,
He, being a methodic sort of man,
Of simple tastes, averse to lily gilding,
Conceived this seeming-reasonable plan:
He would seek an architect of reputation,
One whose soundness was attested by his fame,
And confide himself, relieved of trepidation,
To one who knew the game.

After inquiry among his friends, abetted
By allusions garnered from the public press,
His conservative proclivities were whetted
To approach Horatio Inigo Van Ness.
With reserve that sprang from deference to station
He revealed his simple needs and modest purse,
While Van Ness discoursed of Classic Inspiration
In periods diverse.

Quote:—"We first peruse the plates of best examples
In folios and quartos, leather bound,
Where with diligence and application, samples
Of all prospective motifs may be found.
Let the Parthenon and Baths of Caracalla
Serve as models for the study of your plan,
Though a wayward note of free Pompeian gala
Need not incur the ban.

"With the toilet in the poche of a column,
While pediments the plumbing vents denote,
We achieve that modern synthesis which solemn
Dialect makes incumbent."—end of quote.
But alas! as Tuttle feared, the price transcended
By many times his purse's modest plight,
While on every side the spreading plan extended
Beyond the given site.

Somewhat dazed by this result, but nothing daunted
(Though poorer by Van Ness's ample fee)
He chanced to meet acquaintances who vaunted
The Mediaeval Synthesis (which see).
T. Aquinas Pugin Walpole inculcated
The gospel as revealed by Brother Cram,
A doctrine whose purport, succinctly stated,
Ensues in diagram.

Somewhere 'round about the latter Middle Ages
Mankind indulged an interdicted turn,
Which, by subsequently cumulative stages,
Induced the ills of present-day concern.

So a man who builds a kitchen, bath, or basement,
Aware of these historical arrears,
Must humbly and in cheerful self-effacement
Turn back five hundred years.

This philosophy of past historic lapses,
Translated into structural display,
Was interpreted by chapels, shrines and apses
Where leaded casements dimmed the light of day.
There were gargoyles simulating forms benighted;
A buttress flew across the entrance porch;
All of which, its author seemed to feel, relighted
The waning Christian torch.

For a simple soul in search of simple living
Lighting torches was a luxury pursuit.
He began to harbor touches of misgiving
Lest housing prove a too elusive fruit.
But he realized the times are so conditioned
That modernism's all the rage today;
So to draw a modern dwelling he commissioned
John Doe, F, A, I, A.

Doe's discussion was replete with integration—
Although of what he never gave a clue;
And he dogmatized on interpenetration
Of time and space, and four dimensions too.
Transcendental metaphysics were connived at
In the principle that underlay design,
Which was "Open Plumbing Openly Arrived At"
Reduced to vital line.

His message dealt with function, both as notion
And as mentor to supinely sequent form,
And he talked of stress as fountain of emotion,
Of equilibrium's dynamic norm;
All of which lush philosophical abstractions
Reduced to pipe rails on a terrace roof,
And winging balconies, from whose reactions
Construction held aloof.

Others followed in profusion, advocating
Each one respectively his favored style,
And each, employment duly terminating,
Received his check for drawings placed on file
As he viewed this retrospective panorama
It seemed to say, in sundry styles and ways,
That, like the woman in the melodrama,
The client always pays.

Then at last his patience broke. Resentment rumbled.
He called a conference, inviting all
His former architects; who, nothing humbled,
No more suspecting, headed for their fall.
To his startled guests he read a fervid lecture

Berating each according to his share,
And suggesting where to put their architecture
For all that he might care.

His vocabulary bordered the abusive
As accumulated grievances were aired,
And by way of making Shakespeare more inclusive,
"A plague on ALL your houses," he declared.
Then he stuck his tongue to east, to south, and west
ward,
In identical directions thumbed his nose,
And with this informal recognition guestward
The meeting came to a close.

Having drawn a sketch himself of what he needed
He took it to a builder of repute,
And in terms no misplaced reticence impeded
He made his orders clear, and brief to boot.
"As to what I want, let THIS replace conjecture;
The price can't be augmented by one bob;
If I spot a trace of God damned architecture
I'll kick you off the job."

Now Le Roy Sylvester Tuttle's house is finished
His habitual composure is restored,
And his many friends rejoice in undiminished
Companionship and simple, hearty board.
But whatever be the theme of conversation,
Soon or late the speaker's certain to inject,
"Why, I think your house a genuine creation;
Who was your architect?"

CONTRACTING BUSINESS NOT SO GOOD

One thousand California licensed contractors have quit, died, or have moved leaving no forwarding address, within the past twelve months, according to Arthur Alber, State Registrar, who has announced that over a thousand renewal notices to licensees have been returned by the post office.

Licenses are required of all general contractors and subcontractors, and over 33,000 renewal notices are sent out the first of June requiring the licensee to apply for his new license before June 30th. The renewal fee is \$5.00, and doubles after that date, when it becomes delinquent and the license is automatically suspended.

GLENN STANTON ON STATE BOARD

Glenn Stanton, guest editor of this issue of The Architect and Engineer, and prominent Portland architect, has been appointed by Governor C. H. Martin of Oregon to membership on the State Board of Architect Examiners. The other board members are Francis B. Jacobberger, Portland; Kenneth C. Legge, Portland; John V. Bennes, Frank C. Clark, Medford, and J. E. Tourtellotte, Portland. Mrs. Margaret Gooding Fritsch is secretary of the Board.

Pacific Coast Architects' Chapters

LOS ANGELES ARCHITECTS MEET

Southern California Chapter's delegates to the Seventieth Annual Convention of the American Institute of Architects, held in New Orleans, April 19 to 22, made interesting reports at the regular monthly meeting of the Chapter, June 14.

A. M. Edelman, senior member of the delegation, reported on the National Council of Architectural Registration Boards and gave a resume of the activities of state societies and associations. Accounts of their trips and descriptions of the city of New Orleans were given by Sumner Spaulding and Earl T. Heitschmidt.

The address of Institute president, Charles D. Maginnis, was well worth while, according to Edgar Bissantz, who made a concise report of the business of the convention. Carleton M. Winslow said that the seventy Chapters of the Institute were well represented, the Louisiana Chapter was hospitable and that parts of the program were inspiring.

Guests of the Chapter included Robert E. McClain, S. Kenneth Johnson, William M. Mann, Jan F. Carr, Maria Geier, Hilyard M. Brown, J. S. Butler and Clifford Yates. They are members of the graduating class of the College of Architecture, University of Southern California.

Sumner Spaulding, chairman of the Chapter membership committee, complimented the college on the type of work it is doing and spoke a few words of greeting and encouragement to the students. He introduced John Rex, a member of his staff who graduated from the University of Southern California several years ago.

Eugene Weston, Jr. presided and announced the names of members of the honor awards committee. They are William H. Harrison, Herbert J. Powell, Arthur R. Hutchason, David C. Allison and Gordon B. Kaufmann.

Mr. Weston also announced that Samuel E. Lunden, Henry Carlton Newton and Reginald D. Johnson had been appointed members of a committee on competitions. Mr. Lunden, chairman of the committee, reported progress and invited suggestions of possible projects that would be proper subjects for competitions.

WASHINGTON CHAPTER

Lakewood Center in southwest Tacoma was the scene of the annual gathering of members of the Washington State Chapter, A.I.A., as guests of the Tacoma group. The monthly dinner meeting was held in the community dining hall, with Charles T. Pearson in charge

of arrangements. Lakewood Center is the architectural creation of Silas E. Nelson.

During the afternoon and evening the visiting architects were guests of the Tacoma Society of Architects of which Mr. Pearson is president and Herbert A. Bell, secretary. Nelson J. Morrison was chairman of the day.

George Wellington Stoddard and Floyd A. Naramore tied in the medal play for the Clay Products at the Chapter's annual golf tournament, June 8, at the Maplewood golf course in Seattle.

OREGON CHAPTER

Regular meeting of Oregon Chapter, A. I. A., was held in Hilaire's Restaurant, Portland, June 21. Present were Messrs. Howell, Jones, Aandahl, Johnston, Morin, Schneider, Crowell, Jacobberger, Parker, Herzog, Brookman, Wick, Hilgers, Hayslip, Hartford, Turner, Baer, I. Smith, Barnes, Heims, Zeller, Kotchik and Robert Thompson, the latter a guest.

Mr. Schneider reported on the annual picnic to be held at Carver's Hatton Beach Tuesday, July 19th, promising many surprises, including the possibility of having cold roast turkey.

Mr. Herzog introduced a draft of the new electric code. Much discussion ensued, with objections to Secs. 23 and 24 making it mandatory that complete wiring diagrams be approved by the Building Department before construction permits are issued. It was moved by Mr. Herzog, seconded and passed, that the secretary be instructed to write the O. B. C., sending a copy to City Inspector Going, to-wit:

1st—Objecting to any Code provisions which will not allow an architect to obtain general construction permit approval without full mechanical details, and,

2nd—That the Oregon Chapter desires more time to study balance of Code draft, particularly Secs. 23 and 24 before recommending same.

The secretary reported for Mr. Stanton in reference to the special Oregon number of The Architect and Engineer. It was moved and passed, that the secretary be instructed to order fifty extra copies of this number, paying for same out of Chapter funds, for resale at cost to membership.

The secretary reported for Mr. Logan on the forthcoming exhibition of Hal Onstad's sketches.

Mr. Jacobberger requested that the Chapter's Housing Committee, composed of Messrs. Stanton, Fritsch and Morin, follow the City Council's forthcoming activities with reference to a Housing Authority and report at the July meeting.

Mr. Jacobberger launched forth in a barrage of criticism, couched in no uncertain terms, with reference

to the current Procurement Division's open competition for small postoffice buildings. These sentiments were echoed by several other members, and it was moved that the Chapter take action in the matter. President Howell appointed the following committee to draw up a letter of protest: Messrs. Crowell, Aandahl and Jacobberger.

The secretary reported in reference to Tom Burns' application for Institute Membership.

The secretary reported Southern California Chapter's vitriolic resolution regarding Institute's Small Housing and limited-service activities.—R. L. M.

NORTHERN CALIFORNIA CHAPTER

A regular meeting of Northern California Chapter was held at the St. Francis Yacht Club, San Francisco, at 6:30 P. M., June 21, President Warren C. Perry presiding.

Present: Wm. Clement Ambrose, Henry C. Collins, Gardner A. Dailey, Albert J. Evers, Henry H. Gutterson, Wayne S. Hertzka, Ellsworth E. Johnson, Charles F. Masten, Charles F. Maury, Harry M. Michelsen, Chester H. Miller, James H. Mitchell, Gwynn Officer, Warren C. Perry, Eldridge T. Spencer, Roland I. Stringham, Ernest E. Weihe, Wm. Wilson Wurster, W. Raymond Yelland.

Wm. Wurster, chairman of the exhibit committee, presented a report of the progress made in arranging for the coming exhibit, setting forth the date and space reserved in the San Francisco Museum during the month of October. He also expressed the attitude of the committee, that the exhibit should carry a definite theme and present to the public what the profession is doing to advance architecture in keeping with the trend of the times, and be all-encompassing in a way that will stimulate public appreciation and understanding of this effort.

Various factors that would have direct bearing on the form and scope of the exhibit were discussed and led to the passage of the following motions:

1. Motion by Mr. Weihe—That the exhibit committee be authorized to call upon persons outside the Chapter for assistance and consultation.

2. Motion by Mr. Michelsen—That the exhibit be limited to entries by certificated architects of Northern California.

3. Motion by Mr. Evers—That the Committee shall have discretion to invite group exhibits tending to develop the theme of the exhibit.

4. Motion by Mr. Miller—That the granting of Honorary Awards be discontinued for this particular exhibit.

Mr. Gutterson spoke on behalf of the public relations committee on the matter of a successor to Charles H. Sawyer who is to retire as City Architect. It was instructed that a letter be sent to the Mayor to urge the appointment of a certificated architect to the position.

—J. H. M.

COAST ARCHITECTS WIN PRIZES

Award of 27 prizes totalling \$13,700 has been announced by the New York World's Fair 1939, in two competitions for architects, one for moderate size homes, the other for a neighborhood plan, in which there were approximately 675 contestants, sponsored by the American Gas Association.

As a result of the competition one of the winning designs may be used for a structure in the Fair's "Tomorrow Town," which is to represent the latest ideas in individual and community housing.

The first contest—design of a residence for an average American family, called "Liberty Home" and thoroughly equipped for heating, cooking, refrigeration and water heating—was divided into two classes, one for a home containing 18,000 to 24,000 cubic feet, the other for a home of 24,000 to 32,000 cubic feet. In each class there were four prizes of \$1,000, four of \$300 and four of \$200.

Pacific Coast awards were as follows:

CLASS ONE—First Prize, Alden Becker, 730 North Ardmore Street, Los Angeles.

Second Prize—Frederick E. Emmons, Jr., 1612 Como Street, Los Angeles.

Don Emmons, 803 South Highland Avenue, Los Angeles.

CLASS TWO—Second prize, R. C. Levanas, 224 West 78 Street, Los Angeles.

Third prize—Malcolm P. Cameron and Howard A. Topp, Architects Building, Los Angeles.

Yukio Kako, 837 Laveta Terrace, Los Angeles, California.

Planning section—third prize, James M. Berkey, 517 Radio Central Building, Spokane, Washington.

"This architectural competition," said H. Roy Kelley, of Los Angeles, chairman of the awarding jury, "is one of the largest and, in many ways, most significant one ever held in this country. The designs submitted by architects from all parts of the country and from Canada reveal a distinct trend in domestic architecture. They show the determination to get away from stereotyped designs of homes, to be definitely creative instead of merely reproductive of long-used types.

"It is at once obvious that the contestants have given much thought to the living needs that homes should express. This is disclosed in the manner in which many of them have given highly intelligent consideration to the emplacement of the chief chambers in their houses, the living room, dining room and bedroom. They have situated the living and dining rooms in pleasant relation to the garden, providing both privacy and a pleasant outlook."

COUNTY HOSPITAL ADDITION

Russell G. De Lappe, 1901 Downey Street, Modesto, has had plans approved for a \$25,000 addition to the County Hospital at Modesto.

With the Architects

\$60,000 SCHOOL ADDITION

Messrs. Franklin & Kump, Patterson Building, Fresno, have prepared drawings for a \$60,000 addition to the Delano Grammar School. The same firm have completed preliminary drawings for an addition to the Kings County Hospital at Hanford to cost \$160,000. Other work in this office includes a grammar school at Waukena; a \$15,000 school at Kettleman; a \$20,000 agricultural building at Visalia; a \$20,000 hospital addition at Madera; \$170,000 high school at Dos Palos and a fire house for the city of Fresno.

SACRAMENTO SCHOOLS

The Sacramento school building program will include additions to nearly all the city schools, including an assembly hall for the Judah School; classrooms and assembly hall, El Dorado School; assembly hall for the high school; and a cafeteria for the same building. Plans for all these structures will be prepared by Charles S. Dean, California State Life Building, Sacramento.

Plans for new buildings at the Junior College will be prepared by Architect Harry J. Devine, Cronan Building, Sacramento.

COURT HOUSE ANNEX

A PWA grant has been approved for the construction of an annex to the Redwood City Court House to cost \$240,000. Plans for a two-story concrete building are being prepared by William H. Toepke, 215-7th Avenue, San Mateo.

SAN RAFAEL RESIDENCE

Revised drawings have been made by H. H. Winner, of Ross, for an \$8,000 six-room house in San Rafael for John Morton. The same architect has plans for remodeling the Mechanics and Merchants Bank in Vallejo.

APARTMENT COURT

An \$18,000 apartment court of three units is being designed by E. P. Whitman, 54 Cleveland Avenue, Los Gatos. The house will be situated in Menlo Park.

POLICE STATION AND JAIL

James H. Mitchell, 369 Pine Street, San Francisco, is preparing plans for a one-story reinforced concrete police station and jail to be built in the rear of the Burlingame City Hall at a cost of \$20,000.

ATHERTON RESIDENCE

Plans have been completed and a contract has been awarded for a two-story frame and stucco residence in Atherton, San Mateo County, for Blake Darling, Middlefield Road, Palo Alto. W. W. Wurster, San Francisco, is the architect.

ADMINISTRATION BUILDING

Working drawings have been completed by Williams & Wastell, 374-17th Street, Oakland, for an administration building, boat house and bathhouse at Lake Temescal, in the East Bay Regional Park. The building will be frame and concrete with rustic exterior and wood shake roof.

CITY HALL AND JAIL

Application has been made for a PWA grant to build a \$150,000 city hall and jail at Marysville. Preliminary drawings have been made by Starks & Flanders of Sacramento, who have also been selected as architects for additions to the Crocker & McClatchey Schools in Sacramento.

BERKELEY APARTMENTS

Preliminary drawings are in progress in the office of O. A. Deichmann, 321 Bush Street, San Francisco, for a twelve-unit apartment court at Berkeley, estimated to cost \$35,000.

CITY ARCHITECT TO RETIRE

Charles H. Sawyer, who has been City Architect in San Francisco for a number of years, will shortly retire from active business and his successor will probably be chosen from a list of certificated architects having the approval of the Northern California Chapter.

SANTA ROSA JUNIOR COLLEGE

Preliminary drawings have been completed by C. A. Caulkins, Jr., of Santa Rosa for a group of junior college buildings estimated to cost \$300,000. Application has been made for a PWA grant.

EMERYVILLE FIREHOUSE

Working drawings have been prepared for a one-story frame and stucco firehouse for the City of Emeryville to be built at 61st and Doyle Streets, from drawings by George M. Cantrell, 325 Fremont Street, San Francisco.

SAN FRANCISCO GARAGE

A \$25,000 concrete garage will be built on Pine Street, west of Davis, San Francisco, for John D. and A. B. Spreckels. Harry A. Thomsen is the architect and H. J. Brunner, structural engineer.

\$60,000 CHURCH

The Jesus Christ of the Latter Day Saints Church is building a \$60,000 edifice at 22nd Avenue and Lawton Street, San Francisco, from drawings by Walter C. Clifford, 310 Locust Street, San Francisco.

New Type Concrete Block Wall Sets Record In Fire Test

Fire, water and pressure were used at the Underwriters' Laboratories in Chicago recently to determine the fire-protection provided by a new type of concrete masonry unit. Tests of the 11 by 10 foot wall constructed of solid masonry units were witnessed by members of the Chicago Building Code Council Committee, members of the Engineers' Code Committee and independent engineers and architects. As a result of the test which continued for more than four hours, the 8-inch thick wall was given a 3½-hour fire classification—one-half hour greater than has been given heretofore to any eight inch wall of concrete masonry units.

The masonry units used in the wall were designed by the Portland Cement Association which sponsored the test. According to W. G. Kaiser, manager of the Concrete Products Bureau of the Portland Cement Association, these blocks will soon be available and will provide an economical material for fire resistant construction of fire and party walls in multiple dwellings and commercial buildings.

The units used in the wall were designed to meet the requirements of the building codes of New York (1938), Chicago (1937), and the National Board of Fire Underwriters. The specifications of these codes stipulate that concrete masonry units shall have a void of not more than 25%. The blocks tested had a void space of 24.9% average.

In a large furnace specially designed at Underwriters' Laboratories for fire tests, and burning ten thousand cubic feet of gas per hour—as much as a small city—the wall was subjected to four hours of fire exposure. In the first five minutes of test the fire raised the temperature to 1000 degrees F. At the end of one hour the temperature of the exposed face of the wall was 1700 degrees, at two hours 1850, at three 1925 and at four hours and the completion of the exposure, the temperature was 2000. During the entire test the wall was loaded by means of hydraulic jacks which exerted a pressure 945 pounds each—a pressure of 175 pounds per square inch. This pressure was adjusted during the test so as to remain constant in spite of the expansion of the wall.

At the end of the four-hour fire exposure the red hot wall was immediately withdrawn from the furnace and a hose stream was played over the incandescent face which has been next to the flames. The hose stream was directed from a distance of twenty feet and issued from a 2½-inch fire hose at 45 pounds per square inch pressure. Great clouds of steam were developed as the water struck the hot face. Snapping and cracking were audible from the rapid contraction. The hose stream duplicated the condition which might exist in an actual fire. It was played back and forth

across the wall for 5½ minutes—a time determined by the area of the wall.

The wall remained intact after this test, only slight surface spawling resulting. Architects and engineers examining the wall after the test expressed surprise at the slight effects of such severe treatment.

Temperatures taken on the unexposed face of the wall during the fire exposure resulted in the 3½ hour classification being given. This will automatically be extended to a four hour classification when such walls are surfaced with ¾-inch of gypsum plaster.

ENGINEERS ASSOCIATION REORGANIZED

At the regular meeting of the Engineers and Architects Association of Southern California at Royal Palms Hotel, Los Angeles, June 29, plans for reorganization were perfected. The board of directors was authorized to employ Earl S. Glass as executive secretary. A clause was also written into the By-laws to enable the board of directors to represent member engineers and architects in matters involving their salary scale and employment code.

A. L. Sonderegger, prominent consulting engineer, principal speaker, discussed the meteoric development of Southern California in an address entitled "Nature's Balance."

Sigfred Geotze, housing consultant, appeared in behalf of the California Sponsoring Committee for the Sixteenth International Housing and Town Planning Congress which is to be held in Mexico City August 13-20, 1938. A delegation of architects and engineers and city planners will leave Los Angeles on a specially chartered train on August 5. Lloyd Wright will lead the Los Angeles contingent, which is to be joined at El Paso by another group headed by Frank Wright, architect.

SHASTA DAM CONTRACT

The contract for construction of Shasta dam, on the Sacramento river, has been awarded by Secretary of the Interior Harold L. Ickes, to Pacific Constructors, Inc., of Los Angeles, a syndicate of 12 construction firms, on their bid of \$35,939,450.

Shasta dam will be the key structure of the great Central Valley Federal Reclamation Project, designed to adjust the water fills of an area 400 miles long and in places almost 100 miles wide.

HALL OF RECORDS BUILDING

Modesto is to have a new Hall of Records at a cost of \$136,000. Of this amount, a \$61,000 grant has been approved. Plans for a three-story reinforced concrete building are progressing in the office of G. N. Hilburn, architect, of Modesto.

ARCHITECTS' BULLETIN

Issued For

THE STATE ASSOCIATION OF CALIFORNIA ARCHITECTS

Northern Section

STATE ASSOCIATION MEMBER
OF THE
AMERICAN INSTITUTE OF ARCHITECTS

Editor

Harris C. Allen

Press all communications for publication
of the Bulletin to the Editor (Harris C.
Allen) 557 Market Street, Room 218, San
Francisco, California.

Board of Control

Harris C. Allen Otto G. Hintermann
George P. Michelson Ellsworth E. Johnson
Chester H. Miller

State Association Officers

George P. Michelson, San Francisco, President
George D. Riddle, Los Angeles, Vice-Pres.
Ellsworth E. Johnson, Santa Maria, Secretary
Otto G. Hintermann, San Francisco, Treas.

Regional Director, A. I. A.

Albert J. Evers, San Francisco

**Representative of Regional Director,
Southern California**

Gordon B. Kaufmann, Los Angeles

**Executive Board—Northern Section
Officers**

George P. Michelson.....President
George D. Riddle.....Vice-President
Ellsworth E. Johnson.....Secretary
Otto G. Hintermann.....Treasurer

Directors

Walter E. Baumberger William G. Merchant
George P. Michelson Frederick H. Reimers

**Executive Board—Southern Section
Officers**

George D. Riddle.....President
Gordon B. Kaufmann.....Vice-President
Ellsworth E. Johnson.....Secretary
George H. Orr.....Treasurer

Directors

Walter C. Chambers Lester G. Hibbard
W. P. Edelman W. P. Lodge

S. B. Marston

Advisors—Northern Section

Harris C. Allen Edward R. French, Jr.
F. Ashley Arthur F. Dodman
J. Ballantine Joseph Losevann
Wynne S. Hertzka David H. Horn
Harold T. Kett Robert Stanton
W. L. Garren Charles S. McKenzie
Walter E. Baumberger Henry C. Collins
Thomas E. Pring Leo J. Sharps
Robert Raney Carl F. Gromme
Frederick H. Reimers C. C. Dakin
Walter O. Blodgett F. T. Georgeson
George P. Simonds Ralph D. Taylor
George P. Michelson, Secretary

CONVENTION AFTERGLOW

IN a contemporary periodical is published what purports to be a "Review of the A.I.A. Convention" by one of the California delegates. The querulous, captious tone of the article reminds one of the old story about Johnny's mother watching the company parade—"They're all out of step but Johnny." Ordinarily such criticism would be best ignored. But the misleading statements and inferences, in this case, might do harm if unanswered.

An uninformed reader of this article would conclude:

1. That the Institute "does not pretend to represent ALL practicing architects" (sic). It would hardly seem necessary to repeat that the Institute, without pretense, has for three-quarters of a century represented the profession of architecture and all practicing architects, as the one National Organization; and that the Unification Movement was started mainly to strengthen this position and prevent the possibility of another rival National Organization.

2. That the State Associations were formed "RECENTLY in a few states" (our own Association being now ten years old) but in some miraculous unexplained manner had already been joined together into a second National body—"This tenuous siamese union between the two organizations." There is no basis in fact for either conclusion.

3. That the objectives of the Institute and State Associations are at variance, and that legislative activities were improper for the Institute but not for State Associations. In its Constitution, the objects of the Institute are given as follows:

"To organize and unite in fellowship the architects of the United States of America, to combine their efforts so as to promote the aesthetic, scientific and practical efficiency of the profession, and to make the profession of ever-increasing service to society."

These are also the objects of the State Associations, and it was for reasons of "practical efficiency" that legislative activity was entrusted to them, not because it was not proper for the Institute. Affiliation is bound to make our public policy more efficient and more practical.

4. That unification is not really approved by Institute members; "There is indication that such a convention as this one will not be possible in the future, due to the increasing awareness of many of the delegates of the necessity for intelligent action."

The fact is that a resolution opposing unification (or affiliation) was proposed by the author of this article and three of his fellow delegates; and it was defeated by a vote of 200 (approximately) to 4. In short, Convention action for uniting the entire profession, in definite but flexible method, and creating a special directorship to represent state associations, was practically unanimous.

It is quite probable that this Convention rebuke was responsible for the peevish tone of the article and its unwarranted inferences. A general looseness in writing does not improve the effect. When one reads "such methods may lead inevitably to degradation" one marvels at the discovery of something that MAY happen INEVITABLY!

Such criticism is not constructive. It is, of course, not criticism at all, but argument in garbled form. The public should know that such misunderstandings are rapidly decreasing, and that the architectural profession is in process of becoming officially the unit that it actually and essentially is and must be, for a safe and satisfactory existence.

CONSTRUCTION DATA

For adequate control of construction now, architects should be familiar with many new methods and materials. A large amount of information comes voluntarily through the mail—some of it not only unsought, but unreliable. Attention may be directed to the page headed "Modernized Products" which appears regularly in this journal, as well as the advertisements of materials and services. All of these data have been carefully investigated and offer to architects reliable information. Requests mailed either directly or through "The Architect & Engineer" office will bring more complete and detailed information.

1938 CONVENTION

The convention committees, under the general chairmanship of John K. Ballantine, are at work planning and preparing for a meeting in San Francisco next October which promises to be one of the most interesting and valuable in our history. Reserve the time from October 13 to 16 for this event—and don't forget that special arrangements are being made for entertainment of visiting ladies.

"The Architect & Engineer" will publish a Pre-Convention Number which will also mark the tenth anniversary of the Association.

ADVISORS

It is called to the attention of all Advisors that elections of 1939 Advisors must be called prior to August 15—two months before the Convention—in accordance with our Constitution. Advisors please take notice and call meetings accordingly.

WASHINGTON ARCHITECTS' SOCIETY

Two competitions, one architectural sketching and the other photographic, were announced for summer activity at the monthly dinner meeting of the Washington Society of Architects, June 9. President James M. Taylor is making plans for one summer outdoor affair. The next regular meeting will be September 8.

The freehand sketching competition dealing with an architectural subject will be handled by a committee of which Harry E. Nordquist is chairman. All members of the profession are eligible. The competition featuring photographs and plans of finished work is in charge of a committee headed by Fred J. Rogers. This is open to society members.

BOOK REVIEWS

ANNUALS FOR YOUR GARDEN: By Daniel J. Foley; The Macmillan Co., New York City, N.Y. Price: \$1.00.

A nice book to add to your garden references. It contains the last word in annuals and how to plant and care for them. Well illustrated, brief and most practical, this book is a volume for any home owner with a garden which he himself cares for.

GADGETS AND WRINKLES: By H. A. Calahan; The Macmillan Co., New York City, N.Y. Price: \$3.00.

If you live near the water or own a boat, here is a book that will give you all the little details and as its title implies, all the "gadgets and wrinkles" dear to the heart of the boat owner.

AIR CONDITIONING—HEATING AND VENTILATING: By J. R. Dalzell, and C. L. Hubbard; American Technical Society, Chicago, Ill. Price: \$2.00.

Herein are contained facts and details concerning this most important of building installations. With 571 pages of information, 300 illustrations and 149 tables, there is a wealth of data for the architect and contractor who wish to keep abreast of the modern trends in building. An excellent reference volume and solid technical reading.

PRACTICAL VENEERING: By Charles H. Hayward; J. B. Lippincott Co., Philadelphia, Pa. Price: \$1.75.

A very fine and serviceable little handbook of veneering, especially suited to the reference needs of the worker in wood, and the users of power tools. The book is well written and in understandable language. There are illustrations which enhance the text materially.

STANDARD PLUMBING DETAILS: By Louis J. Day; John Wiley & Sons, Inc., 440 Fourth Ave., New York, N.Y. Price: \$6.00.

Another of the splendid "Standard" series. This volume should be the book that the plumbing contractors with vision have been waiting for. It is filled with fine detail and a wealth of useful data.

LOUIS J. GILL HONORED

Louis J. Gill, architect of San Diego, and prominent in the affairs of the State Association of California Architects, has been conferred the degree of Doctor of Fine Arts by Syracuse University, of which school Mr. Gill is an alumnus. Syracuse was the first university in the United States to give the degree Bachelor of Architecture. The Department of Architecture was founded in 1870.

Mr. Gill, now in his fifty-third year, took the degree Bachelor of Architecture at Syracuse in 1911. He has practiced architecture in San Diego since that year.

Structural Engineers Association of Northern California

OFFICERS

Harold B. Hammill, President

S. S. Gorman, Vice President

H. M. Engle, Secretary-Treasurer

Other Directors:

F. F. Hall

A. V. Saph, Jr.

Important Commission

Harold M. Engle of San Francisco has been commissioned to do the structural design for a group of four new buildings for the San Rafael High School. He is also working on plans for the reconstruction of a grammar school for the City of Sausalito, and supervising the alteration work at the Eagles Hall in San Francisco.

Engineer for Alterations

Mac D. Perkins of San Francisco is working on two additions and alterations in connection with the Palo Alto Grammar School, and is also working on one new school for the Town of Palo Alto. He has likewise been called on to report on the structural condition of the Salinas rodeo grandstands and to make a design for strengthening the same. Mr. Perkins is also working on a design of a net dipping plant at Fisherman's Wharf.

Adrian Solves Problem

William Adrian, Market Street, San Francisco, is consulting engineer for the Marin Dairymen's Building at 13th & Howard Streets, San Francisco, and had a very unusual condition in reference to the foundations of this building. Running water, approximately fifteen feet below the street grade, was found which necessitated a unique foundation design. Mr. Adrian will elaborate on the interesting solution to this problem in a later issue.

Brunnier a Busy Man

Past President H. J. Brunnier was a busy man last month as chairman of the "Host" committee to 12,000 Rotarians from all over the world. Mr. Brunnier is past president of the San Francisco Rotary Club, was the first governor of the San Francisco Rotary District, and was first vice president of Rotary International.

"Full" Professor

Professor James Bertrand Wells was made a "full" professor last month. Professor Earl C. Thomas was similarly honored last year.

Notes—Personal and Otherwise

William E. Emmett is arranging for an exhibit of competitive designs for an elevated structure sponsored by the American Institute of Steel Construction some time in the near future in San Francisco.

George Washington was unable to attend the Struc-

tural Engineers picnic on June 1st. Reason: Anita Louise (March 20) sister to George, Junior, age 8 and Mary Louise, age 4. (Arithmetic progression.)

R. S. Chew cooperated with Professor R. E. Davis in the preparation of a Shearing Test on plywood frames, anticipating their use in the Federal Building of the Golden Gate International Exposition.

William H. Popert, publicity chairman, is away for a well-earned vacation. Everyone remembers that Bill had a very serious operation last fall, and we all hope that the rest will put him back on his feet and restore his old-time pep and energy.

J. E. Mackie, manager of the Western office of National Lumber Manufacturers Association, has moved his office to Room 278 Monadnock Building, 681 Market Street, San Francisco. Telephone—Garfield 2417.

Speakers at L. A. Meeting

William E. Emmett, Field Engineer of the American Institute of Steel Construction, was chairman on Section "Materials of Construction, Quality, Use and Inspection" at the Tenth Annual Institute of Government held in Los Angeles, June 13th to 17th. J. C. Mackie delivered a lecture on "Lumber," and Mr. M. C. Poulsen also represented the Structural Engineers.

Named Principal Engineer

Director Sidney S. Gorman was recently appointed principal construction engineer of the California Commission for the Golden Gate International Exposition, with headquarters at 660 Market Street, San Francisco, and on Treasure Island.

LETCHFIELD ADDRESSES ENGINEERS

Members of the San Francisco section, American Society of Civil Engineers, on June 21 heard a first-hand description of the current situation in Industrial Europe when F. T. Letchfield, consulting engineer and assistant vice-president of the Wells Fargo Bank, told of his recent visit to France, England and Germany.

Addressing the bi-monthly meeting of the section, Mr. Letchfield used as his topic, "Backstage in Europe's Industries." As one of a group of 25 American scientists, Mr. Letchfield visited 46 European research laboratories during his recent tour.

"Industrial research, progress, and philosophy in Europe," he declared, "have been strongly influenced by the political backgrounds of the individual countries."

GEOLOGISTS STUDY ARTIFICIAL EARTHQUAKES

ARTIFICIAL earthquakes, set off by powerful quarry blasts, will be studied by geologists this summer to determine the structure of the earth's crust to depths more than twenty miles below the surface it is announced by the Geological Society of America. Observing staffs will be stationed at varying distances from several quarries in New England with instruments more delicate and more sensitive than those usually employed in measuring real earthquakes.

Dr. Louis B. Slichter, professor of geophysics in Massachusetts Institute of Technology, will direct the study under a grant of \$5,350 from the Penrose Bequest of the Society. Dr. Slichter hopes that the recording of the blasts will shed light on the popular geological hypothesis that the earth's crust is composed of a number of layers of rock, not unlike the physical makeup of the onion.

Fresh knowledge concerning the structure of the earth's crust at depths of twenty miles and more, and new data on the nature and depth of the transition from the layer of granite to the underlying rocks, is one object of the investigation. At present, it is explained, the earth is conceived by some geologists to consist of a series of concentric shells; an outer layer of sedimentary rocks, an underlying granite-gneiss shell, a shell of peridotite or basic rock, and a core of nickel and iron, with a transitional layer between the peridotite and the core. To bolster or deflate this theory is another objective.

Twelve super-sensitive portable seismographs, specially designed by Dr. Slichter for the project, will be placed at regular intervals within 100 miles or more from the point of the blast to record the results of the man-made earthquakes. Supplemented by radio receiving apparatus and a central control board, each seismograph station will be equipped to record the most microscopic tremors. More than twenty-four observers will man the field stations.

The gigantic blast will be recorded on instruments scores of miles away as a series of jagged lines. So delicate are the supersensitive seismographs that they are capable of detecting a ground movement as slight as a hundred-thousandth of an inch. The size of the blast will determine the distance at which the field stations will be located.

Scientists expect to supply information on the nature of rocks at varying depths by measuring the time elapsing between the detonation and the recording of the shock at the field stations. Through a microphone and radio transmitting apparatus at the scene of the blast, all field stations are simultaneously apprised of the explosion, which is automatically recorded on a tape.

When the ground tremors finally reach the machine

through different underground paths, they are registered on the same tape. The space on the tape between the record of the blast as received by the radio and the record marked by the seismograph gives the time consumed by the tremors in reaching the field stations. These records will be analyzed and calculated by special machines at the Massachusetts Institute of Technology.

Seismic waves, Dr. Slichter explained, travel more swiftly in rocks of increasing depth. He expects that his research this summer will determine accurately how swiftly wave velocities travel in the deeper crustal rocks. The part played by depth in the variation of wave velocities will also be investigated.

While the actual field work will be completed this summer, the entire program, including interpretation of the results in the laboratories of the Massachusetts Institute of Technology, will occupy a year.

Construction of the field equipment was financed in part by an earlier grant of \$3,000 from the Penrose Bequest, in part by Godfrey L. Cabot and in part by the Whitney Fund at M. I. T.

The Penrose Bequest was established in 1932 under the will of Dr. Richard A. F. Penrose, Jr., a former president of the Geological Society of America, to promote research in geology and related sciences. Grants totaling more than \$269,000, embracing nearly 250 projects, have already been made.

LEIPZIG FAIR DATES ANNOUNCED

The 1980th session of the Leipzig Trade Fair will be held from August 28th to September 1st, inclusive. It will comprise some 6,000 exhibits of the newest products of thirty-two countries. To accommodate the increased exhibits two large exhibition halls will be added to the forty-two buildings already in use. The entire space of several of the halls has already been engaged. An attendance of a quarter of a million exhibitors and buyers attracted from seventy-four countries is assured. Several important congresses of industrial leaders from many countries will be held in connection with the Fair which serves as a world clearing house for new ideas and products. The total turnover for the Spring Fair was \$217,000,000, an increase of 10 per cent over 1937 and 262 per cent over 1933. The export sales totalled \$70,000,000.

WINS NATIONAL PRIZES

First prize in the residential remodeling division and the sweepstakes prize for all four divisions of the 1937 national competition, conducted by Better Homes and Gardens magazine, were won by Alvin E. Erickson, architect, Central Building, Everett, Wash. The project involved improvement of the E. A. Adams residence, Arlington, Wash., by removing the front porch, adding four new rooms and redesigning the exterior.

Estimator's Guide

Living Cost of Building Materials, Wage Scale, Etc.

Amounts given are figuring prices and are made up from average quotations furnished by material houses to San Francisco contractors. 3% Sales Tax on all materials but not labor.

prices and wages quoted are for San Francisco and the Bay District. There may be slight fluctuation of prices in the interior southern part of the state. Freight charge, at least, must be added in figuring dry work.

-1 1/2% amount of contract.

Common. \$40 to \$45 per 1000 laid, (according to class of work).

Car-load lots delivered \$2.70, f.o.b. cars \$2.52

(Cloth sacks) \$3.00 bbl..

Rebate 10 cents bbl. cash in 15 days.

Atlas White } 1 to 100 sacks, \$1.50 sack,
Calaveras White } warehouse or delivery; over 100
Medusa White } sacks, \$1.25; 2% discount 10th of month.

Forms, Labors average \$40.00 per M.

Average cost of concrete in place, exclusive of forms, 35c per cu. ft.;

with forms, 60c.

4-inch concrete basement floor 12 1/2c to 14c per sq. ft.

Rat-proofing 7 1/2c

Concrete Steps \$1.25 per lin. ft.

Cement (paper sacks) \$3.00 bbl., warehouse or delivery.

Car-load lots delivered \$2.70, f.o.b. cars \$2.52

(Cloth sacks) \$3.00 bbl..

Rebate 10 cents bbl. cash in 15 days.

Atlas White } 1 to 100 sacks, \$1.50 sack,
Calaveras White } warehouse or delivery; over 100
Medusa White } sacks, \$1.25; 2% discount 10th of month.

Forms, Labors average \$40.00 per M.

Average cost of concrete in place, exclusive of forms, 35c per cu. ft.;

with forms, 60c.

4-inch concrete basement floor 12 1/2c to 14c per sq. ft.

Rat-proofing 7 1/2c

Concrete Steps \$1.25 per lin. ft.

Dampproofing and Waterproofing—

Two-coat work, 20c per yard.

Membrane waterproofing—4 layers of saturated felt, \$4.50 per square.

Hot coating work, \$1.80 per square.

Medusa Waterproofing, 15c per lb., San Francisco Warehouse.

Tricocel waterproofing.

Electric Wiring—\$12.00 to \$15.00 per outlet for conduit work (including switches).

Knob and tube average \$3.50 per outlet.

Elevators—

Prices vary according to capacity, speed and type. Consult elevator companies.

Average cost of installing an automatic elevator in four-story building, \$2800; direct automatic, about \$2700.

Excavation—

Sand, 60 cents; clay or shale \$1 per yard.

Teams, \$12.00 per day.

Trucks, \$22 to \$27.50 per day.

Above figures are an average without water. Steam shovel work in large quantities, less; hard material, such as rock, will run considerably more.

Fire Escapes—

Ten-foot galvanized iron balcony, with stairs, \$115 installed on new buildings; \$140 on old buildings.

Floors—

Composition Floors—22c to 40c per sq. ft. In large quantities, 16c per sq. ft. laid.

Mosaic Floors—80c per sq. ft.

Duraflex Floor—23c to 30c sq. ft.

Rubber Tile—50c to 75c per sq. ft.

Terazzo Floors—45c to 60c per sq. ft.

Terazzo Steps—\$1.60 lin. ft.

Hardwood Flooring (delivered to building)—

3 1/2 x 2 1/4" T & G Maple \$ 88.00 M ft.

1 1/2 x 2 1/4" T & G Maple 115.00 M ft.

7/8 x 3 1/2" sq. edge Maple 100.00 M ft.

	3 1/2 x 2 1/4"	3/4 x 2"	3/4 x 2"
	T & G	T & G	5/8 Ed.
Clr. Qtd. Oak	\$120.00 M	\$ 82.50 M	\$110 M
Sel. Qtd. Oak	99.00 M	69.50 M	84 M
Clr. Pla. Oak	106.00 M	74.50 M	86 M
Sel. Pla. Oak	97.00 M	62.50 M	76 M
Clear Maple	111.00 M	100.00 M	
Laying & Finishing	14c ft.	12c ft.	10c ft.
Wage—Floor layers,	\$10.00.		

Note—Above quotations are all board measure except last column which is sq. ft.

Glass (consult with manufacturers)—

Double strength window glass, 20c per square foot.

Plate 75c per square foot (unglazed) in place, \$1.00.

Art, \$1.00 up per square foot.

Wire (for skylights), 40c per sq. foot.

Obscure glass, 30c square foot.

Glass bricks, \$2.40 per sq. ft., in place.

Note—If not stipulated add extra for setting.

Heating—

Average, \$1.90 per sq. ft. of radiation, according to conditions.

Warm air (gravity) average \$40 per register.

Forced air, average \$60 per register.

Iron—Cost of ornamental iron, cast iron, etc., depends on designs.

Lumber (prices delivered to bldg. site).

No. 1 common \$29.00 per M

No. 2 common 27.00 per M

Select O. P. common 34.00 per M

2x4 No. 3 form lumber 24.00 per M

1x4 No. 2 flooring VG 55.00 per M

1x4 No. 3 flooring VG 47.00 per M

1x6 No. 2 flooring VG 60.00 per M

1 1/4 x 4 and 6, No. 2 flooring 60.00 per M

Slash grain—

1x4 No. 2 flooring \$43.00 per M

1x4 No. 3 flooring 40.00 per M

No. 1 common run T. & G. 30.00 per M

Lath 5.25 per M

Shingles (add cartage to price quoted)—

Redwood, No. 1 \$1.10 per bdle.

Redwood, No. 290 per bdle.

Red Cedar 1.10 per bdle.

Millwork—Standard.

O. P. \$85.00 per 1000. R. W., \$90.00 per 1000 (delivered).

Double hung box window frames, average, with trim, \$6.50 and up, each.

Doors, including trim (single panel, 1 3/4 in. Oregon pine) \$8.00 and up, each.

Doors, including trim (five panel, 1 3/8 in. Oregon pine) \$6.00 each.

Screen doors, \$3.50 each.

Patent screen windows, 25c a sq. ft.

Cases for kitchen pantries seven ft. high per lineal ft., \$8.00 each.

Dining room cases, \$8.00 per lineal foot. Rough and finish about 75c per sq. ft.

Labor—Rough carpentry, warehouse heavy framing (average), \$17.50 per M.

For smaller work average, \$35.00 to \$45.00 per 1000.

LOW TILE FIREPROOFING (f.o.b. job)

2x12 in. \$ 84.00 per M

2x12 in. 94.50 per M

2x12 in. 126.00 per M

2x12 in. 225.00 per M

LOW BUILDING TILE (f.o.b. job)

load lots.

2x5 1/2 \$ 94.50

2x5 1/2 73.50

ing Paper—

ly per 1000 ft. roll \$3.50

ly per 1000 ft. roll 5.00

ly per 1000 ft. roll 6.25

nskin, 500 ft. roll 4.50

nskin, Pro-tect-o-mat, 1000 ft. roll 9.00

1 1/2 ft. roll 5.00

cord com. No. 7 \$1.20 per 100 ft.

cord com. No. 8 1.50 per 100 ft.

cord spot No. 7 1.90 per 100 ft.

cord spot No. 8 2.25 per 100 ft.

weights cast iron, \$50.00 ton, \$3.50 base.

weights, \$45 per ton.

rete Work (material at San Francisco)

workers—Quotations below 2000 lbs. to ton. \$2.00 delivered.

3 rock, at bunkers \$1.45 per ton

4 rock, at bunkers 1.45 per ton

ott top gravel, at bunkers 2.10 per ton

shed gravel, at bunkers 1.45 per ton

ott top gravel, at bunkers 2.10 per ton

ly gravel, at bunkers 1.45 per ton

er sand, at bunkers 1.40 per ton

livered bank sand 1.00 cu. yd.

—Above prices are subject to discount 2% per ton on invoices paid on or before the 10th of month, following delivery.

Monte, \$1.75 to \$3.00 per ton.

Shell Beach (car lots, f.o.b. Lake Mailla), \$2.75 to \$4.00 per ton.

1938

Marble—(See Dealers)

Painting—

Two-coat work	36c per yard
Three-coat work	50c per yard
Cold Water Painting	10c per yard
Whitewashing	4c per yard
Turpentine, 65c per gal., in 5 gal. cans, and 55c per gal. in drums.	
Raw Linseed Oil—97c gal. in bbls.	
Boiled Linseed Oil—\$1.00 gal. in bbls.	
Medusa Portland Cement Paint, 20c per lb.	

Pioneer or Dutch Boy White Lead in Oil (in steel kegs). Per lb.

1 ton lots, 100 lbs. net weight	101/4c
500 lbs. and less than 1 ton lots	101/2c
Less than 500 lb. lots	11c

Pioneer or Dutch Boy Red Lead and Litharge (in steel kegs).

1 ton lots, 100 lb. kegs, net weight	101/4c
500 lbs. and less than 1 ton lots	101/2c
Less than 500 lb. lots	11c

Pioneer Red Lead in Oil (in steel kegs)

1 ton lots, 100 lb. kegs, net weight 111/4c	
500 lbs. and less than 1 ton lots	111/2c
Less than 500 lb. lots	12c

Note—Accessibility and conditions cause some variance in costs.

Patent Chimneys—

6-inch	\$1.25 lineal foot
8-inch	1.75 lineal foot
10-inch	2.25 lineal foot
12-inch	3.00 lineal foot

Plastering—Interior—

2 coats, brown mortar only, wood lath	Yard \$0.75
2 coats, lime mortar hard finish, wood lath	1.00
2 coats, hard wall plaster, wood lath85

3 coats, metal lath and plaster	1.30
Keene cement on metal lath	1.30
Ceilings with 3/4 hot roll channels metal lath75
Ceilings with 3/4 hot roll channels metal lath plastered	1.50
Single partition 3/4 channel lath 1 side85
Single partition 3/4 channel lath 2 sides 2 inches thick	1.50
4-inch double partition 3/4 channel lath 2 sides	1.30
4-inch double partition 3/4 channel lath 2 sides plastered	3.00

Plastering—Exterior—	Yard
2 coats cement finish, brick or concrete wall	\$1.00
2 coats Calaveras cement, brick or concrete wall	1.35
3 coats cement finish, No. 18 gauge wire mesh	1.50
3 coats Calaveras finish, No. 18 gauge wire mesh	1.75
Wood lath, \$7.50 to \$8.00 per 1000.	
2.5-lb. metal lath (dipped)17
2.5-lb. metal lath (galvanized)20
3.4-lb. metal lath (dipped)22
3.4-lb. metal lath (galvanized)28
3/4-inch hot roll channels, \$72 per ton.	
Finish plaster, \$18.90 ton; in paper sacks.	
Dealer's commission, \$1.00 off above quotations.	
Hydrate Lime, \$19.50 ton.	

Plasterers Wage Scale	\$1.25 per hour
Lathers Wage Scale	1.25 per hour
Hod Carriers Wage Scale	1.10 per hour
Composition Stucco—	\$1.80 to \$2.00 sq. yard (applied).

Plumbing—

From \$70.00 per fixture up, according to grade, quantity and runs.

Roofing—

"Standard" tar and gravel, \$6.50 per sq. for 30 sqs. or over.	
Less than 30 sqs. \$7.00 per sq.	
Tile, \$20.00 to \$35.00 per square.	
Redwood Shingles, \$7.50 per square in place.	
Copper, \$16.50 to \$18.00 per sq. in place.	

Cedar Shingles, \$8.00 per sq. in place.
Recoat, with Gravel, \$3.00 per sq.
Asbestos Shingles, \$15 to \$25 per sq. laid,
Slate, from \$25.00 to \$60.00 per sq. according to color and thickness.

Sheet Metal—

Windows—Metal, \$1.75 a sq. foot.
Fire doors (average), including hardware, \$1.75 per sq. ft.

Skylights—(not glazed)

Copper, 90c sq. ft. (flat).
Galvanized iron, 30c sq. ft. (flat).
Vented hip skylights 60c sq. ft.

Steel—Structural

\$120 ton (erected), this quotation is average for comparatively small quantities. Light truss work higher. P. beams and column work in large quantities \$90 to \$100 per ton.

Steel Reinforcing—

\$80.00 to \$120.00 per ton, set.

Stone—

Granite, average, \$6.50 cu. foot in place.
Sandstone, average Blue, \$4.00, \$3.00 sq. ft. in place.
Indiana Limestone, \$2.80 per sq. ft. in place.

Store Fronts—

Copper sash bars for store fronts, corner center and around sides, will average 75c per lineal foot.
Note—Consult with agents.

Tile—Floor, Wainscot, etc.— (See Dealers)
Asphalt Tile—18c to 28c per sq. ft. stelled.

Venetian Blinds—

40c per square foot and up. Install extra.

THE BUILDERS' EXCHANGE OF SAN FRANCISCO STANDARD WAGE SCALE

For mechanics employed on construction work in the Bay Region. Effective September 1, 1937

CRAFT	Journeymen Mechanics
Asbestos Workers	\$ 8.00
Bricklayers (6h-5d)	10.50
Bricklayers' Hodcarriers (6h-5d)	6.75
Cabinet Workers (Outside) (5d)	8.00
Coisson Workers (Open)	6.40
Carpenters (8h-5d)	10.00
Cement Finishers (8h-5d)	10.00
Cork Insulation Workers (8h-5d)	9.00
Electric Workers (8h-5d)	11.00
Electrical Fixture Hangers	8.00
Elevator Constructors	10.40
Engineers, Portable & Hoisting	9.00
Glass Workers (8h-5d)	9.68
Hardwood Floormen	9.00
Housemiths, Architectural Iron (Shop) (8h-5d)	9.00
Housemiths, Architectural Iron (Outside) (8h-5d)	10.00
Housemiths, Reinforced Concrete or Rodmen (8h-5d)	10.00
Iron Workers (Bridge and Structural) Including Engineers (8h-5d)	12.00

CRAFT	Journeymen Mechanics
Laborers, Building (8h-5d)	\$ 4.00
Laborers, Common (8h-5d)	6.00
Lathers, Channel Iron (6h-5d)	9.00
Lathers, All Others	9.00
Marble Setters (8h-5d)	10.50
Marble Setters' Helpers (8h-5d)	5.00
Millwrights	9.00
Model Makers (\$1.50 per hr-6h)	9.00
Modelers (\$2 per hr-6h)	12.00
Model Casters	7.20
Mosaic and Terrazzo Workers (Outside)	9.00
Painters (7h-5d)	8.50
Painters, Varnishers and Polishers (Outside)	9.00
Pile Drivers and Wharf Builders	9.00
File Drivers' Engineers	10.00
Plasterers (6h-5d)	10.00
Plasterers' Hodcarriers (6h-5d)	7.50
Plumbers (8h-5d)	11.00
Roofers, Composition (8h-5d)	9.00
Roofers, All Others (8h-5d)	8.00
Sheet Metal Workers (8h-5d)	10.00
Sprinkler Fitters	10.00

CRAFT	Journeymen Mechanics
Steam Fitters (8h-5d)	11.00
Steel Builders (8h-5d)	10.00
Stone Cutters, Soft and Granite (8h-5d)	10.00
Stone Setters, Soft and Granite	10.00
Stone Derricksman	10.00
Tile Setters (8h-5d)	10.00
Tile Setters' Helpers (8h-5d)	9.00
Tile, Cork and Rubber (8h-5d)	10.00
Welders, Structural Steel Frame on Buildings	10.00
Welders, All Others on Buildings	10.00
Dump Truck Drivers, 2 yards or less	8.50
Dump Truck Drivers, 3 yards	9.00
Dump Truck Drivers, 4 yards	9.50
Dump Truck Drivers, 5 yards	10.00
Dump Truck Drivers, 6 yards	10.50
Dump Truck Drivers of Concrete Mixer Trucks:	
2 yards or less	8.50
3 yards	9.00
4 yards	9.50
5 yards	10.00
6 yards	10.50

GENERAL WORKING CONDITIONS

- Eight hours shall constitute a day's work for all crafts except as otherwise noted.
- Plasterers' Hodcarriers, Bricklayers' Hodcarriers, Roofers, Laborers, and Engineers, Portable and Hoisting, shall start 15 minutes before other workmen, both at morning and at noon.
- Five days, consisting of not more than eight hours a day, on Monday to Friday inclusive, shall constitute a week's work.
- Transportation costs in excess of twenty-five cents each way shall be paid by the contractor.
- Overtime shall be paid as follows: For the first four hours after the first eight hours, time and one-half. All time thereafter shall be paid

- double time. Saturdays (except Laborers), Sundays and holidays, from 12 midnight of the preceding day, shall be paid double time.
- On Saturday, Laborers shall be paid straight time for an eight-hour day.
 - Where two shifts are worked in any twenty-four hours, shift time shall be straight time. Where three shifts are worked, eight hour's pay shall be paid for seven hours on the second and third shifts, allowing one-half hour for lunch.
 - All work, except as noted in paragraph 9, shall be performed between the hours of 8 a.m. and 5 p.m.
 - In emergencies, or where premises cannot be vacated until the close of business, men then

- reporting for work shall work at straight time. Any work performed on such jobs after night shall be paid time and one-half for four hours of overtime and double time thereafter, provided, that if a new crew is employed on Saturdays, Sundays or holidays which not worked during the five preceding days such crew shall be paid time and one-half.
- Recognized holidays to be: New Year's, Decoration Day, Fourth of July, Labor Admission Day, Thanksgiving Day, Christmas Day.
 - Men ordered to report for work, for whom employment is provided, shall be entitled to two hours' pay.

MODERNIZED PRODUCTS

Brief Notes on New Materials and Equipment in the Building Industry.

63a. ABOUT LEAD

Two interesting booklets on the uses of lead in the building industry. Issued by the Lead Industries Association. Well illustrated.

LIGHTING

The Pittsburgh Reflector has issued another excellent catalogue entitled "Lamps, Lamps and Urns," No. 39. A coupon will bring you a copy.

INSULATION

Mikolite Company announces a line of cork-like mineral insulation in a new brochure. This product is for use in residences and public buildings as well as for use in industrial plants.

BOILERS

A new broadside issued by Crane Company deals with "stoke-fired boilers" and is gotten up in a very interesting manner; send for your copy.

RUST DEFYER

The Parker Rust-Proof Company announces processes for defying rust in iron and steel products. Plenty of explanatory text and well illustrated.

VALVES

A complete catalogue with description matter has just been issued by the Weststead Valve Company. The content in will assure you of a copy of your files.

ALL ABOUT PLYWOOD

An old friend is with us again; a new issue of Harbordata, issued by the Harbor Plywood Corporation. As before, this little sheet always contains interesting news of interest.

WELDING

Bulletin No. R-5 has been issued by the Harnischfeger Corporation, dealing with P. & H. "smootharc" welding electrodes; this bulletin should be well worth adding to your files; send in the coupon for a copy.

71. AIR CONDITIONING

"Enjoy a cool summer in a nature conditioned house" is the title of a broadside issued recently by the American Radiator Company. It contains information of interest and value.

72. BOILERS

The same company has also issued a complete catalogue on "ideal" cast iron boilers. This booklet gives the latest information on these units.

73. MORE INSULATION

Celotex Corporation has issued an interesting broadside dealing with insulation material, especially adapted for the use of the home builder. Cut out the coupon and send in for your copy.

74. NEW HEATING UNIT

From the York Ice Machinery Company comes a broadside illustrating "Yorkaire" heating; this is a new unit and has several interesting features.

75. FLOORING

In the form of a news-sheet the Haselkete Manufacturing Corporation has issued some interesting data on compound flooring. Send for your copy.

76. GLASS

Two little folders detailing some new products of the Pittsburgh Plate Glass Company and the Casein Company, have been issued through the Oakland Lumber Co. These will be found to contain information of value to builders.

77. FLOOR TILE

The Belmont Products Company has put out a fine brochure on floor tile, stair treads and copper tile. This is the first time we have had the pleasure of reviewing any of this company's literature and believe that our readers will find the booklet of great interest.

78. UNIQUE SHEET

Carrier Corporation has a news letter called "International News." A unique little sheet; the cover of the May issue is amusing as well as interesting. Send for your copy.

79. AIR CONDITIONING

The Modine Manufacturing Company's new booklet on air conditioning is an attractive booklet; well arranged and nicely illustrated.

FREE FOR THE ASKING

Check items on coupon, paste on letter head or postal card, and mail to Architect and Engineer.

Architect and Engineer
68 Post Street
San Francisco, Calif.

Please send me literature on the following items as checked below. This request places me under no obligation.

- | | | | |
|--------|--------------------------|----|--------------------------|
| 63-63a | <input type="checkbox"/> | 71 | <input type="checkbox"/> |
| 64 | <input type="checkbox"/> | 72 | <input type="checkbox"/> |
| 65 | <input type="checkbox"/> | 73 | <input type="checkbox"/> |
| 66 | <input type="checkbox"/> | 74 | <input type="checkbox"/> |
| 67 | <input type="checkbox"/> | 75 | <input type="checkbox"/> |
| 68 | <input type="checkbox"/> | 76 | <input type="checkbox"/> |
| 69 | <input type="checkbox"/> | 77 | <input type="checkbox"/> |
| 70 | <input type="checkbox"/> | 78 | <input type="checkbox"/> |
| | | 79 | <input type="checkbox"/> |

My Name.....
Name of Company.....
Street.....
City..... State.....

CRANE COMPANY NEW KITCHEN CABINET SINKS

THREE new kitchen cabinet sinks are being introduced by Crane Co., 836 South Michigan Avenue, Chicago, Ill., . . . the "Kitchen Queen," "Kitchen Pride," and "Homemaker."

Largest and most complete of the three is the "Kitchen Queen," 72 inches long, 36 inches high, with a two-sink compartment 8 inches deep. There are two drainboards depressed to prevent water from running over the edge. The back is 4 inches high so that the sink may be accommodated under a window. The sink is in one piece—acid-resisting enamel on cast-iron.



Crane "Kitchen Queen" Cabinet Sink

Other features of the "Kitchen Queen" are a retractable spray hose, controls placed at a comfortable angle, swinging mixing spout, safety ledge for drying stem ware, recessed center panel to allow knee room, two removable containers for fruits and vegetables concealed by a small door, sliding towel rack, recessed toe space, linoleum-lined cutlery compartment, removable cup strainer and hand-operated stopper and removable wooden cutting board.

There are four deep drawers, two shallow drawers, space beneath the sink for storage in the all steel cabinet and a wire utility rack for holding soap.

* * *

Where a sink is desired for a continuous counter the "Kitchen Pride" with its two compartments, 8 inches deep, is recommended by Crane Co. Features of this sink include water controls at a comfortable angle, swinging mixing faucet, retractable vegetable spray, 4-inch high back, safety ledge for drying stemware, acid-resisting porcelain enamel on cast-iron. There are three types in this model, varying in design, cabinet arrangement and facilities. The sink is 38 x 25 $\frac{1}{4}$ inches and 36 inches high.

Where a practical sink for the small home is desired Crane Co. offers the "Homemaker." It has a porcelain enamel, acid-resisting finish on cast iron and chromium-



Crane "Kitchen Pride" Kitchen Sink with De Luxe Cabinet

plated hardware at a comfortable angle on the panel. The sink has two different styles of all-steel cabinets with varied arrangements of drawers and interior facilities. The drainboard is depressed to prevent water from splashing on the floor. The back of the sink is 4 inches high to make it easy to place under windows.

There is a safety ledge for drying stemware, a swinging spout and removable cup strainer. Also available



Crane "Homemaker" Kitchen Sink

with this sink is a retractable spray hose. The sink, which is available in sizes 42 x 25 $\frac{1}{4}$ inches or 52 x 25 $\frac{1}{4}$ inches, 36 inches from the floor, may be installed as a separate unit or continuous with counter.

85 Per Cent of Building Minus Architectural Service

THE production of small houses must approximate the mechanism of other large scale products which the public buys, it is declared in a report of the Small House Committee of the New York Chapter of the American Institute of Architects, of which Harvey Stevenson is chairman.

"It cannot succeed unless it is done on a large scale," says the report. "The costs at the moment are too high to induce individual production. This means that from the producer's point of view the house must be handled from start to finish with the closest cooperation between financing, designing, construction, and supervision. From the purchaser's point of view the finished product must be produced at a given price without the distraction and uncertainties of dealing with disassociated controls."

A plan to secure professional supervision for the 85 per cent of building which now receives no architectural service was outlined in the report. The plan envisions "central offices," wherever justified by demand, from which the potential client, whether an individual or a developer, could obtain the necessary information and advice, and could make all arrangements so that the completed building or buildings would be satisfactory to himself, the lending institution, and the Government.

"These offices should have a supervising architect directing the standards of design and supervision," it is asserted. "The production of the designs, the arrangements for designing for the client, and the apportionment of fees could all be worked out as soon as the fundamental premises are assured.

"When the house or houses are completed in a manner satisfactory to the lending institutions they would receive a stamp of approval, the significance and value of which would be properly publicized. It is conceivable that the market value of this 'seal' would become sufficient to lead developers to conform to the requirements laid down in order to obtain this stamp.

"The first hurdle to be overcome is the competitive quality of the individual lending institutions. If it is possible for the architects and the technical participants to collaborate it ought to be possible for the financial institutions to do the same.

"This cooperative effort suggests other facilities which the individual institution cannot afford to maintain at a high standard; for example, a skilled inspector from a central organization can handle the work of inspection for a number of operations better than a dozen less competent inspectors working full or part time for the various individuals."

A primary reason for professional service, according to the report, is the safeguarding of loans, particularly when these loans are amortized only over long periods. "In relation to this factor the raising of standards and all esthetic considerations are, as far as making the proposition a business one, secondary."

"The architects have tried to improve this situation at their own expense. They cannot afford to do it. No real advance in the standards of small homes is to be expected till the bulk of the lending institutions is prepared to require uniform standards of professional control as a prerequisite to their loans; and, furthermore, to bear the expense of setting up and maintaining such control as an insurance on their own money."

Although officials of various lending institutions are sympathetic to the "central office" plan, competition and the recession deter them from independent action, the committee says. "Federal influence naturally suggests itself," the report continues, adding that the plan should receive its first test in the smaller communities.

"The interest of the Washington organizers of the Federal Home Loan Bank in their plan, which is substantially the same as ours, continues most solicitous. It has chances of success in Westchester and in medium-sized communities where the building interests are concentrated in a few hands and civic pride is a more intimate asset. It falls down in the metropolitan area because there is not enough business of this variety to encourage the bank's individual members in uniform development of competent personnel and methods in the face of probable sacrifices of cash and autonomy.

"The Federal Housing Authority is everywhere and provides an Olympian terminal to which the buck may be passed. When asked if professional supervision could not be insisted upon as a prerequisite to FHA guarantees, the Authority answered that this could be done only where communities, as in the case of Memphis, Tenn., were already organized with this service in full swing.

"The FHA could not, at least not now in the face of Government pressure for immediate production, do anything that might handicap volume. Here again, if any such plan is to be tried it should be begun in those smaller communities where the bulk of building is individually owned and where all the interested parties may be organized to demand professional control as community interest. The FHA, or any big business for that matter, will support any plan for building that a whole community wants.

"An outline of the plan in Los Angeles, which is apparently still sufficiently civic-minded to compensate for its size, is worthy of scrutiny. It is directed by a board of financiers, building material company hands, members of the Real Estate Board, and architects. The chairman is a local FHA architect. Preliminary financing is loaned by those interested. Management cost is to be met by membership fees, sale of portfolio of designs, and 10 per cent of all architectural fees received.

"The architects contribute the portfolio designs and receive a small fee for each submitted, and a further fee from the mortgage lender for working drawings.

In general, the service provided is a limited one, with standard forms. The principal is identical with the original New York plan with the incomparable advantage of pledged funds and FHA-sponsored direction."

The report declares that "the Small House Committee of the New York Chapter does not deny that a 10 per cent fee is none too much for the individual private house job; nor does it deny that there is a definite cash value to disinterested professional service from the small home-builder's viewpoint, and that where such service is dispensed with 'to keep costs down,' the speculative builder often spends many times the cost of the service in promotion, salesmanship and advertising."

"But the committee does repeat that about 85 per cent of building receives no architectural service under the existing inept attitude; that all building should have such service, and that if the client cannot afford it he should buy a finished house from someone who can; that operating companies in most thickly settled areas can alone afford to produce sufficiently cheap houses; and that as 'big' business finds small house building to be good business, the standard of production is bound to improve. The architect must be willing and able to inject himself into this collaborative picture."

MOST BEAUTIFUL BRIDGES

The most beautiful bridges of steel built during the past year are:

Golden Gate Bridge, San Francisco, California;

The Little Hell Gate, Low Level Bridge, New York City;

Chesterfield-Brattleboro Bridge, New Hampshire;

Marine Parkway Bridge, New York City.

Announcement of these awards was made at the Engineers' Club on Thursday evening, June 23, at a dinner extended by the American Institute of Steel Construction to the Jury of Award and the engineers and architects concerned with the construction of the bridges. The awards were made in four classes, namely, monumental, medium, and small size bridges, and movable bridges.

The jury selecting the prize-winning bridges this year consisted of:

Prof. H. E. Wessman, College of Engineering, New York University;

Mr. William H. Yates, Consulting Engineer;

Mr. L. Andrew Reinhard of the architectural firm of Reinhard & Hofmeister;

Mr. William Lescaze, Architect;

Mr. Kenneth Reid, Editor of Pencil Points;

all of New York City.

In connection with the jury's report the following description of the Golden Gate Bridge is given:

"Class A, First Place—Golden Gate Bridge—from Fort Point to Lime Point across the Golden Gate at San Francisco, California; Total cost \$27,000,000 (construction cost); Engineers, Joseph B. Strauss, Chief Engineer; Consulting Engineers, O. H. Ammann, L. S.

Moisseiff and Charles Derleth, Jr.; Fabricators, Bethlehem Steel Company; Owners, Golden Gate Bridge and Highway District; Date completed, May 26, 1937; Opened to traffic, May 27, 1937; Span length: Main span, 4,200 feet, center to center of towers; Total length 9,200 feet.

"Class C, First Place—Chesterfield - Brattleboro Bridge—Over Connecticut River on Route 9; Total cost, \$198,425.72; Engineers: John W. Childs, Bridge Engineer, Harold E. Langley, Designing Engineer, New Hampshire State Highway Department; Fabricators, Bethlehem Steel Company; Owners, States of New Hampshire and Vermont; Date completed, August 2, 1937; Open to traffic, July 31, 1937; Span length, 425 feet, center to center pins.

"Movable Bridge Class, First Place—Marine Parkway Bridge—Over Rockaway Inlet, New York City; Total cost, \$3,750,000; Engineers, Madigan-Hyland, Consulting and Supervising Engineers on entire project; Waddell & Hardesty, Consulting Engineers on design of lift and flanking spans; Robinson & Steinman, Consulting Engineers on design of deck spans; Aymar Embury II, Consulting Architect; Fabricators and Erectors, American Bridge Company; Owners, Marine Parkway Authority; Date completed and opened to traffic, July 3, 1937; Span length, lift span, 540 feet.

"Class B, Honorable Mention—Northern Boulevard Bridge Over Intramural Drive—Flushing Meadow Park, New York City; Total cost \$448,376; Engineers, Madigan-Hyland; Fabricators, American Bridge Company; Owners, Department of Parks, City of New York; Date completed, September 10, 1937; Opened to traffic, June 8, 1937; Span lengths: 7 spans at 49.5 feet center to center of columns.

"Movable Bridge Class, Honorable Mention—Shark River Bridge—Ocean Avenue, between Belmar and Avon, Monmouth County, New Jersey; Total cost, \$324,982.68; Engineers, Ash-Howard-Needles & Tammen, and Morris Goodkind acting as Associate Consultants; Fabricators, Virginia Bridge Company, structural steel; American Bridge Company, machinery; owners, Board of Chosen Freeholders of Monmouth County, New Jersey; Date completed and opened to traffic, May 29, 1937; Span lengths: Double leaf simple trunnion bascule span 112 feet center to center of trunnions, and two flanking spans each 68 feet long; Total length 338 feet, 8 inches."

"CONSULT YOUR ARCHITECT" MOVIES

The "Consult Your Architect" Motion Picture Council, 551 Fifth Avenue, New York, sponsoring a series of consumer education film programs on home modernization and new construction, is enlisting an advisory board.

Film productions, designed for showing to clubs, civic organizations and adult groups, are being planned and supervised by D. Everett Waid, F.A.I.A., and a former president of the American Institute of Architects.



KLAATH FALLS BRANCH, U. S. NATIONAL BANK OF PORTLAND
 Architects: J. P. Whitney & Aandahl, Architects
 Contractors: Drake, Wyman & Voss, Contractors

Cream and bronze Ceramic Veneer expresses permanence and dignity in the facade of this bank building.

GLADDING, McBEAN & CO.

Manufacturers of Clay Products

SAN FRANCISCO LOS ANGELES SEATTLE PORTLAND OAKLAND SPOKANE VANCOUVER, B. C.

*Modern Homes are
Air-Conditioned by*

SELECTAIR

● DESIGNED and built by the S. T. Johnson Co., pioneer manufacturers of Oil Burners, this smart new air-conditioner combines in one compact unit every feature desired by home-owners, architects and engineers for economical heating, air-conditioning and ventilating the modern home. Year-round hot water. Forced air circulation for summer. Equipped with the popular BANKHEAT Pressure-Type Burner. Furnished in enamel with chrome trim.

Send for "Selectair" Bulletin & complete specifications

S. T. JOHNSON CO.

Oil Burners

940 Arlington Avenue, Oakland, California
401 Broad Street, Philadelphia, Pa.

● THERE'S A JOHNSON OIL BURNER FOR EVERY PURPOSE

"Goods of the Woods"

Dependable Building Materials

Lumber and Millwork

for

All Types of Construction

★

**Wolmanized or Creosoted
Lumber and Timbers
is your protection against
Termites and Decay**

★

E. K. WOOD LUMBER CO.

San Francisco

Los Angeles

Oakland

WINDOW CONDITIONING CAMPAIGN

A broad advertising and merchandising program to focus attention upon the most important single form of insulation—window conditioning by means of double glass—is being launched by the Libbey-Owens-Ford Glass Company.

Designed primarily to educate the public to the many advantages of window conditioning, the campaign will be conducted in such a way as to be of direct benefit to the building industry.

Fundamentally, it will stress the fact that despite the great progress made by twentieth century methods to increase the efficiency, comfort and convenience of the home, one thing has been forgotten—the most important form of insulation, double glazing of windows and doors by one method or another.

"It is highly important to remember that the benefits to be derived by the building industry from this program do not depend alone upon new construction," said John D. Biggers, president of Libbey-Owens-Ford, in announcing the campaign.

"There are 12,000,000 homes in the United States with central heating plants. This vast number of dwellings represent an immediate market for window conditioning."

In focusing nation-wide attention upon window conditioning, Libbey-Owens-Ford will specifically promote the interests of lumber dealers. Such phrases as "See Your Lumber Dealer," and other specialized copy, will be given prominence in all advertisements and supporting literature so as to give lumbermen every possible merchandising advantage.

Sash and door manufacturers and their affiliates will be assisted by national advertising and other material designed to boost the products they have to sell. As a further effort to make the campaign as all-inclusively helpful as possible, Libbey-Owens-Ford will promote the interests of carpenter contractors and heating and air-conditioning manufacturers. The program will also prove of definite interest to speculative builders and operators of rentable properties.

It is significant that Libbey-Owens-Ford does not contemplate a brief campaign, but rather a program of carefully scheduled activities designed to build up interest over an extended period so as to assure increasing and permanent benefits both to the building industry generally and the consumer.

SORORITY HOUSE

A twenty-room sorority house for the Alpha Delta Pi will be built at Corvallis, Oregon, from plans by Architect E. L. Snyder, of Berkeley.

COLLEGE HALL ADDITION

A \$10,000 addition will be built to Lisser Hall at Mills College, Oakland, from plans by W. H. Ratcliff, Jr., Berkeley.

ARCHITECTURAL PORCELAIN ENAMEL

Professor R. M. King, technical director of the Porcelain Enamel Institute, talked to the Eastern Enameler's Club at Baltimore recently on "Architectural Porcelain Enamel—Its Qualities and Its Future."

"Porcelain enamel on steel," said Professor King, "is aiding the architect with modern ideas to satisfy the public with a variety of form and color and to attain a maximum of magnificence with a minimum of material and money."

The first house finished in porcelain enamel was erected in Germany in 1895, but in Russia there is a church with porcelain enameled panels in the doors which are reputed to be 300 years old.

Trends in architecture, such as streamlining, functionalization, re-styling, and pre-fabrication are forcing the use of new materials, and new methods. Porcelain enameled sheets can easily be used in buildings which have felt these modern influences.

Enamel is at present being quite extensively used on stores, office buildings, schools, laboratories, theaters and restaurants. It has many qualities which make it desirable in these fields.

PROMENADE TRAFFIC TOP

The Celotex Corporation of Chicago has launched a vigorous sales drive for a new product, Promenade Traffic Top, with which flat roofs may be converted into open air playgrounds, roof gardens and recreational areas for sun bathers.

Sales efforts are being concentrated in cities where congestion places limits on recreational space, and utilize the appeal of adding usable areas to buildings at little cost.

The new product is applied over the roof, and protects the roofing from damage by traffic and rays of the sun. It is made of cane fiber impregnated with asphalt and provides a resilient, non-slippery wearing surface. It is supplied in three colors—black, green and red.

When used on apartment buildings, hotels, hospitals, factories and homes it gives occupants additional space for sun bathing and various forms of recreation and utility. Additional play areas may be provided for schools and children's homes above the danger of city traffic. Hospitals and sanitariums may provide open air space for convalescents without securing additional ground area.

The State Association of California Architects will celebrate its Tenth Anniversary in October.

THE ARCHITECT AND ENGINEER
Will Publish a Special Number
That Month.

ENGINEERED HARDWARE

FOR NEW SCHOOL CONSTRUCTION

DALMO SIMPLEX WINDOW FIXTURES

"THE NATION'S SCHOOLHOUSE WINDOW"

HAVE BEEN USED IN OVER 200
SCHOOLS IN CALIFORNIA IN THE
PAST TWO YEARS

KRAMER FLUSH VALVES

SHEER SIMPLICITY OF CONSTRUCTION
MAKES FOR POSITIVE PERFORMANCE
AND LOW MAINTENANCE

MacDONALD 
HARDWARE MANUFACTURING CO.

YUkon 0123

963 Harrison St.

San Francisco



For GAS HEAT choose the DELCO CONDITIONAIR

Built and Backed by General Motors

● This extremely efficient unit automatically warms, purifies, humidifies and circulates the air—supplies complete winter air conditioning to which summer cooling can easily be added. A quality product of unusual efficiency with the plus value of the "General Motors" name. Also models for oil heat. Get complete specifications from —

ALADDIN HEATING CORPORATION

Delco - Frigidaire Dealer

2222 SAN PABLO AVENUE • OAKLAND

**Pressure
Treated Lumber?**

Specify

BAXCO C Z C

**"Chromated Zinc
Chloride"**

**Protects against decay
and termite attack**

•
*Available for prompt shipment
throughout California*

•
J. H. BAXTER & CO.

601 W. 5th Street
LOS ANGELES
Phone Mlchigan 6294

333 Montgomery Street
SAN FRANCISCO
Phone DOuglas 3883

The Popularity Of WILLAMINA BRICK

Is indicated by the class of Oregon architects
employing WILLAMINA BRICK in the following
buildings featured in this "Oregon" issue.

Library, University of Oregon, Eugene, Ore.,	Page 28
First Unit, Tuberculosis Hospital, University of Oregon, Portland, Oregon	Page 29
Lawrence, Holford & Allyn, Architects	
All Saints School, Portland, Oregon	Page 38
Francis B. Jacobberger, Architect	
Library, Willamette University, Salem, Ore.	Page 37
Finley's Mortuary, Portland, Oregon	Page 36
Art Museum, Portland, Oregon	Page 36
A. E. Doyle and Associates, Architects	
Town Club, Portland, Oregon	Page 23
Johnson, Wallwork and Dukehart, Architects	
Regent Apartments, Portland, Oregon	Page 41
Harry A. Herzog, Architect	
Senior High School Building, Salem, Oregon	Page 39
Knighon and Howell, Architects	
Goetz & McGee Mortuary, Portland, Oregon	Page 30
Barrett & Logan, Architects	
Irvington School, Portland, Oregon	Page 36
George H. Jones, Architect	

**WILLAMINA
CLAY PRODUCTS CO.**

0132 S. W. MILL ST., PORTLAND, ORE.

NEW GRADE PLYWOOD SHEATHING

A substantial contribution to the current demand for practical low-cost housing is shown in the development of a new grade of Douglas Fir Plywood Sheathing which is being grade-marked and scored under the name Plyscord. Announcement of the availability of the new product is made by W. E. Difford, managing director of the Douglas Fir Plywood Association.

The new grade has been standardized by all members of the Association to meet the needs of architects, contractors, and builders for a sheathing that is easy to apply, economical to use and which will, at the same time, add strength and rigidity to homes.

Each panel of Plyscord will be plainly marked and scored with parallel lines across the panel. The lines are spaced 16 inches apart and when the carpenter lays the panel horizontally over the studs, the lines indicate their exact location for nailing. The scoring is also helpful in locating studding when siding is to be laid over the sheathing.

The scoring lines on the panels consist of a substantial blue line over which the name Plyscord is printed every few inches. Allowance for imprinting the name of the individual producing mill is made between the words Plyscord.

Plyscord will be available in standard 8-foot lengths, 32" and 48" widths and in 5/16", 3/8" and 5/8" thicknesses. These sizes were decided upon after consulting architects, contractors, and builders for their suggestions. For most ordinary structures it was found that 5/16" and 3/8" thicknesses would be suitable, but where maximum strength and rigidity is a factor, the 5/8" thickness is to be recommended.

The new sheathing grade has an improved face and presents a solid surface. There are no large knot holes or pitch pockets and the stripping of paper tape is reduced to a maximum of not more than two to each panel.

Extensive tests and research indicates that builders may expect a saving of more than 50 per cent in nailing. Because of the large panels, also, there will be labor savings in cutting and fitting as compared with ordinary types of horizontal or diagonal sheathing.

Many builders have commented on the appearance of model homes sheathed with Plyscord, adding that it has a favorable effect upon prospective home-owners who visit the projects during construction. This type of sheathing, they say, gives builders a realistic picture of the reasons why Plyscord sheathing makes walls warmer and windproof, while at the same time adding strength to the entire structure.

Jesse M. Warren, architect of Washington and a leader in real estate development in the northeastern district of Seattle, recently was named business manager of the Hillman Investment Co., 1012 E. 65th Street, Seattle. He will have direct charge of the company's building program.

CALIFORNIA ARCHITECTS WIN

Seven California architects and students of architecture were among the winners of national home design and town planning competition sponsored by the American Gas Association in collaboration with Architectural Forum. A first prize of \$1,000 was awarded a design for a model home submitted by Alden Becker, student of architecture at the University of Southern California. Another student at this university, Yukio Kako, was awarded a third prize of \$200. The firms of Frederick E. Emmons, Jr. and Don Emmons, Hollywood architects; and Malcolm P. Cameron and Howard A. Topp, Los Angeles architects, each won \$200 third prizes; and a \$300 second prize was won by R. C. Levans, U. S. C. graduate, who is a home designer in the firm of R. W. Middlebrook, developer of "Lakewood Village" in North Long Beach.

The contest was divided into two parts, competition in house design and in neighborhood planning. There were two classes in the former, the first for a house of either one or two stories of 18,000 or 24,000 cubic feet content for comfortable all-year occupancy by a moderate-income family consisting of parents and two or three children with income from \$2,000 to \$7,000 yearly. The second class is similar except that the cubic content shall range from 24,000 to 32,000 feet.

In each class there was requirement of separate detail plan of kitchen and basement or utility room, including laundry, and further that the structures should contain all necessary equipment to use gas for cooking, water-heating, house-heating, refrigeration, clothes drying and other laundry appliances. The awards in each class were: Four prizes of \$1,000, four of \$300 and four of \$200.

In the neighborhood planning contest, the first prize was \$1,000; second, \$500; third, \$500; the competition being to plan a complete neighborhood for families of diverse occupation with incomes ranging from \$2,000 to \$7,000 a year.

The winning designs will be displayed in Pacific Coast cities later on.

CERTIFICATES TO PRACTICE

State Board of Architectural Examiners, Southern Division, June 14 issued provisional certificates to the following persons to practice architecture in California: Donald Port Ayres, 7970 Sunset Boulevard, Hollywood; Harold James Bissner, 595 E. Green Street, Pasadena; John Northcliffe Douglas, 408 Ninita Parkway, Pasadena; Charles Elwyn DuBois, 2409 W. 59th Street, Los Angeles; Henry Lawrence Eggers, 327 S. Alexandria Avenue, Los Angeles; Jay Herbert Ellsworth, 9815 Wilshire Boulevard, Beverly Hills; Wm. H. Godwin, 2053 Kerwood Avenue, Los Angeles; Carl Collins McElvy, 3464 E. 7th Street, Los Angeles; John Leon Rex, 220 California Bank Building, Beverly Hills; James Cecil Strawn, 1516 Sherbourne Drive, Los Angeles.

Equipped with Corrosiron Fan



Life Science Building, University of California, Berkeley

Federal, State and Municipal Architects Specify

—CORROSIRON—

fans, ducts, drain pipes and fittings because they are acid-resisting

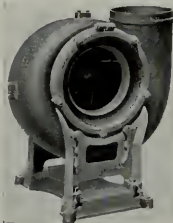

Corrosiron Fan

Architects and Mechanical Engineers

write for suggested specification form to

Pacific Foundry Co., Ltd.

New York Los Angeles
3100 Nineteenth Street, San Francisco, Calif.

BUILD WELL

A PROPERLY designed and well constructed building is a credit to any city and a profitable investment for its owner.

Such structures are the STANDARD OIL BUILDING, MATSON BUILDING, FOUR-FIFTY SUTTER STREET, STOCK EXCHANGE, S. F. BASE BALL PARK, MILLS TOWER, OPERA HOUSE and VETERANS' MEMORIAL, San Francisco, OLYMPIC CLUB ALTERATIONS, SANTA ANITA RACING PLANT and other notable structures — all built or supervised by —

Lindgren & Swinerton, Inc.

Standard Oil Building 605 W. Tenth Street
San Francisco Los Angeles

We Maintain a Termite Control Department

OREGON ARCHITECTS

for the past 30 years
have successfully used

COLUMBIA BRICK PRODUCTS

in many of Oregon's
outstanding building
projects.

COLUMBIA BRICK WORKS

—Manufacturers—

BRICK • STRUCTURAL HOLLOW TILE • FIREPROOFING

1390 S. E. WATER AVE. — PORTLAND, OREGON



ARCHITECTS and their clients are quick to appreciate the decorative effectiveness of the new Lightoliers—especially in view of their sound construction and reasonable cost. Available in all periods, at dealers nationally or at our show-rooms.

Write for "The Charm of a Well Lighted Home" — to help you plan attractive healthful lighting.

INCANDESCENT SUPPLY CO.

SAN FRANCISCO : OAKLAND : FRESNO : LOS ANGELES

The better homes of today are
AIR CONDITIONED
for year-round weather

Consult us for the answer to your problems
MANUFACTURERS



OIL FIRED FURNACES
GAS FIRED FURNACES
SHEET METAL PRODUCTS

Harer-Perry Company

5662 Keith Ave., Oakland, Cal.
Phone HUmboldt 7928

A Permanent Exposition
of the newest ideas
in home planning
and equipment.



THE BUILDING MATERIAL EXHIBIT

Architects Bldg. • Fifth & Figueroa • Los Angeles • MU-6306

WINNERS OF LANGLEY SCHOLARSHIP

Among the seven winners of the Edward Langley scholarship for 1938-39, announced by the American Institute of Architects, is Jack Donald Gilchrest, architectural draftsman of Santa Barbara, California, who will study at Harvard, Columbia or the University of Pennsylvania, and John T. Jacobsen, architect of Seattle, awarded a scholarship for travel in Europe and eastern United States to study low cost housing.

Before going abroad Mr. Jacobsen will call on Colman Woodbury and Hugh Pomeroy of the National Association of Housing Officials, and Walter Blucher, executive secretary of the American Society of Planning Officials, in Chicago.

The Edward Langley Scholarship was made available to the American Institute of Architects by Edward Langley, architect of Scranton, Penn., and is awarded each year to outstanding architects for the purpose of advanced study, research and travel. The award is made on character, ability and purpose.

Mr. Jacobsen was born in Seattle, attended West Seattle High School and is a graduate of the University of Washington in architecture. He also took a post-graduate course in architecture at the University of Pennsylvania and obtained his Master's degree there. Prior to practicing architecture in Seattle, he was in the offices of Cram & Ferguson of Boston

Jack Donald Gilchrest of 1532 Mountain Avenue, Santa Barbara, California, the other Pacific Coast scholarship winner is thirty-two years old and a native of Santa Barbara. He was proposed by John Frederick Murphy, Santa Barbara architect, as one "whose qualifications and achievements have demonstrated outstanding ability in his chosen work."

Mr. Gilchrist has been engaged in architectural work since 1924, when he entered the office of Soule, Murphy and Hastings in Santa Barbara. He was graduated from Santa Barbara High School in 1925. In 1926-27 he was associated with Louis E. Davis in Honolulu. Returning to Santa Barbara, he worked as draftsman in the offices of Edwards, Plunkett and Howell, of Russell Ray, and of Lockwood deForest, Jr. From 1928 to 1930 he was employed by Virgil Westbrook at San Clemente. Since 1935 he has been with Soule and Murphy.

POMONA TILES

FOR

Bathrooms and Kitchens
in over 60 colors

Warehouses and Display Rooms

135 Tenth St. . . . San Francisco

629-33 North La Brea Ave. Los Angeles

6106 Roosevelt Way . . . Seattle

POMONA TILE MFG. CO.
PLANT — POMONA, CALIF.

INCLUDE TREES IN YOUR PLANS

DAVEY, ORIGINATOR OF TREE SURGERY, OFFERS FREE INSPECTION AND ESTIMATE.



SAN FRANCISCO Fresno LOS ANGELES
 Russ Bldg. Maffei Bldg. Story Bldg.
 SUITE 3377 TUCKER 1929
 Local phones in: Pasadena, Palo Alto,
 Oakland, San Rafael, San Mateo

SKILL - KNOWLEDGE - RESPONSIBILITY

KILL TWO BIRDS WITH ONE STONE



1 INSULATION 2 ATTRACTIVE INTERIOR FINISH

At the Cost of Insulation Alone

FIR-TEX gives you double your money's worth, by doing two jobs at the cost of one.

Fir-TEX, the modern dual-purpose insulating board, does these two things. (1) Takes the place of ordinary structural materials; (2) Gives you the finest insulation money can buy.

One of the many double-duty uses of Fir-TEX is for interior finish plus insulation.

For Double Value, Use Fir-TEX These 3 Ways

A Interior Finish plus Super Insulation: The Fir-TEX Ivorykote board has a beautiful mottled ivory

Fir-TEX Insulating Lath gives you a smooth, crack-resisting job. Seals the room from top to bottom.

C Outer Sheathing plus Super Insulation: Fir-TEX Fir-kote Sheathing takes the place of wood sheathing and building paper. Has a glazed surface; clean to handle. Is water-proofed throughout. May be sawed and nailed without breaking any seal. Has greater bracing strength than lumber. Wind-proof, dust-proof. Encloses house with an unbroken area of insulation.

Clean, White Wood Fibres
 Fir-TEX is made from clean, white natural fibres of sound wood. These

STRUCTURAL STEEL

For Class A Buildings,
 Bridges, etc.

JUDSON PACIFIC CO.

609 MISSION STREET
 SAN FRANCISCO

Plants: San Francisco - Oakland

USE BASALITE

Light-weight, pre-fabricated Concrete building products for floors, walls, and roofs in your next building.

BASALT ROCK COMPANY, INC.

Napa, California

NOISE Control

Office Quieting
 Sound-proof Partitions
 Acoustical Correction

WESTERN ASBESTOS CO.

Building Materials Mechanical Specialties
 SACRAMENTO OAKLAND
 SAN FRANCISCO



In this room Fir-TEX both beautifies and insulates. The walls are of the popular new Fir-TEX Ivorykote—the super insulating board with the attractive mottled ivory surface. Fir-TEX makes the room more comfortable in summer and winter by providing a barricade against outside temperatures. Fir-TEX also stops outside noises.

surface. Smooth and washable. Use Ivorykote to finish rooms in any part of the house—living room, dining room, bedroom, recreation room, or to make an extra bedroom in the attic. If desired, Ivorykote may be kalsomined or painted without further sizing. Provides insulation continuity of walls and ceiling.

B Plaster-base plus Super Insulation: The modern way to prepare walls for plaster is to use Fir-TEX Insulating Lath. The Insulating Lath is nailed directly to the studding. Eliminates plaster wastage, which is common with ordinary lath. Lath marks are unknown.

fibres are sterilized, "felted", and pressed into rigid boards. Water-proof throughout; vermin-proof; fire-retardant.

Buy Fir-TEX at your building materials dealer. Send for beautifully illustrated book, "Double Value for Your Insulation Dollar." Dant & Russell, Inc., National Distributors, Porter Bldg., Portland, Oregon.



FIR-TEX

The Double-Duty Insulating Board





No longer a problem
for the Architect

TRANSIT MIX CONCRETE AND MORTAR

makes delivery of material to the job swift and inexpensive . . . minimizing the architect's supervision costs and assuring his client a dependable mix.

Speed . . . Reliability . . . Economy
Let us co-operate with you

Golden Gate-Atlas Materials Co.

16th and Harrison Streets
San Francisco
UNderhill 3650

Modern Design Dignified and Good Looking



Model No. 75

This new semi-recessed HAWS DRINKING FOUNTAIN is made of Vitreous China and answers a demand for an attractive, well built fixture for public and semi-public buildings.

HAWS DRINKING FAUCET CO.
1808 Harman Street Berkeley, Calif.

OUR ARCHITECT SAVED US \$700



"**W**E figured conservatively that our architect saved us \$700 on our \$7,000 home, and that's not taking into consideration the increased beauty and livability that has enhanced the value of our home materially. * Even in the case of our hot water heater, which cost less than 1% of the total—the architect could have specified any one of thirty makes—but he insisted on **DAY AND NIGHT**. He explained that it costs no more than the conventional types—yet it has exclusive gas saving features that will pay for the total cost of the heater through lower gas bills. We wouldn't have known about the patented **HEAT TRAP—HEAT WAVE FLUE** and other features that have outmoded the old system of water heating. We are glad now that he insisted on a **DAY AND NIGHT** Water Heater. Its saving will continue month after month, and we will be thankful we had an architect every time we receive our gas bill." * If you're considering building a new home or replacing your old water heater, mail this coupon today for the complete answer to your water heating problem.

DAY and NIGHT WATER HEATER COMPANY MONROVIA, CALIFORNIA

Day and Night Water Heater Co.
Monrovia, California

Please send me the free booklet,
"How to Cut Gas Bills 33 1/3%."

Name _____
Address _____
City _____ State _____

Donovan Automatic Awning Type Windows

Give 100% natural ventilation
and day-lighting control

UNIVERSAL WINDOW
COMPANY
Berkeley, California

"AMERICAN MARSH" Redi-Vac Vacuum Heating Pump

Send for
Bulletin 441



SIMONDS MACHINERY CO.
San Francisco 816 FOLSOM ST. Los Angeles 522 EAST 4TH ST.

SISALKRAFT

REG. U. S. PAT. OFF.

"More than a
building paper"

THE SISALKRAFT CO.
205 West Wacker Drive
(Canal Station) Chicago, Ill.
55 New Montgomery Street
San Francisco, Calif.

Pacific Manufacturing Company

High Class Interior Finish
Quality Millwork

454 Montgomery St. 6820 McKinley Ave.
San Francisco Los Angeles
GARfield 7755 THornwall 4196

1315 Seventh Street, Oakland
GLencourt 7850



CLIENTS will bless you for installing the Wesix "49'er" ELECTRIC BATHROOM HEATER. But try it first in your own home. Certain that you will like its forty-nine inches of INSTANT RADIANT HEAT and QUICK CIRCULATING HEAT, we are offering this smart new heater at factory cost to architects, for personal use. Limit one heater per architect. List price \$21.50. Please write on your regular letterhead, to: 1018 WESIX BLDG., SAN FRANCISCO

WESIX
WESIX ELECTRIC HEATER CO.



**HERRICK
IRON WORKS**

STRUCTURAL STEEL

18TH AND CAMPBELL STS.
OAKLAND, CALIF.

Phone G Lencourt 1767

**FORDERER
Cornice Works**

Manufacturers of

Hollow Metal Products
Interior Metal Trim
Elevator Fronts and Cabs
Metal Wall Plugs, Anchors, Etc.
Sheet Metal Products
Sanitary Metal Base
Commercial Refrigerators
Building Paper
Metal and Wire Accessories
for Concrete

269 POTRERO AVENUE
San Francisco, Calif.

HEmlock 4100
CONSULT. OUR ENGINEERING
DEPARTMENT

GOOD CONSTRUCTION MONTH

Total construction contracts awarded in the 37 Eastern States during the month of May reached the largest dollar total since July of last year, according to F. W. Dodge Corporation. The May 1938 total figure was \$283,156,000, which was an increase of 28 per cent over the preceding month, and an increase of 16 per cent over May 1937. While the increase was largely in the heavy engineering classifications, residential building also showed a decided increase over the preceding month and compared more favorably with the corresponding month of 1937, than has any preceding month this year. Privately financed work of all kinds was only 8 per cent less in dollar volume than in May of last year, while publicly financed work increased 55 per cent.

Residential building contracts, with a total of \$83,153,000, were only 1 per cent behind May of last year, and represented the largest dollar volume recorded since June of last year.

WILL DISCUSS SAFETY LAWS

Safety laws and orders of eleven Western States are the subject of a survey to be made by a new W.P.A. project at a cost of \$10,000. This project, just approved by the Federal government at Washington, will be directed by C. H. Fry, Chief of the Industrial Accident Commission of California, and Interim Chairman of the Western Safety Conference to be held in Los Angeles, September 12-16.

Under the provisions of the project, 27 experienced safety engineers and attorneys will unite in re-codifying all safety laws and orders for the prevention of accidents.

Robert W. Hunt Company
ENGINEERS

Inspection - Tests - Consultation
Schools and Other Structures
Are Built as Designed

When Construction Materials are Inspected at point of Manufacture and during Erection by

ROBERT W. HUNT COMPANY

Cement, Concrete, Chemical, Metallurgical, X-Ray and Physical Laboratories

Chicago - New York - Pittsburgh
Los Angeles - All Large Cities
San Francisco, 251 Kearny Street



Going away?

Leave Worries Behind!

Our booklet, *An Introduction to Agency Service*, tells how we would collect the income, execute orders through your own broker for purchases and sales, collect principal upon maturity, etc.,... relieving you of all bothersome routine connected with your investments.

You may have a copy, on request. Ask for booklet M-2



PAN-AMERICAN

(Simplex)



Model 12

AUTOMATIC OIL BURNER

The model illustrated is the smallest of many sizes and types of oil burners built by

**PAN - AMERICAN
ENGINEERING CO.**

820 Parker Street • Berkeley
Phone B ERkeley 6755

Pitcher

Improved
Disappearing Doors
Save 20% Space

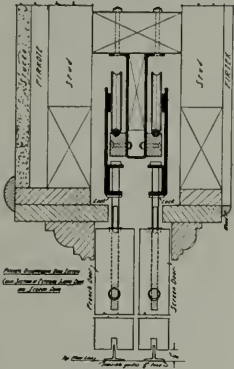

Joins with a 3 1/2" stud wall . . . steel studs
adjustable steel and wood track.
Can be used for screen doors in connection
with French doors. Send for detail drawing.

E. C. Pitcher Co.
461 Market Street
San Francisco

Independent Iron Works

Structural Steel
Ornamental Iron
Steel Service Stations
Steel Tanks
Standard Steel Mill Buildings
Bridges

821 Fine Street Oakland

Clinton Construction Co. of California General Contractors

923 Folsom Street
San Francisco
SUtter 3440

HIGH FINED

Kraftile

THE TERRA COTTA WITH THE 12 ADVANTAGES

Master Kraftile . . . Terra Cotta Wall
Units . . . Ceramic Facings . . . Cutting
Machines . . . Swimming Pool Ladder
Steps . . . Swimming Pool Overflow
Hand Rails . . . Bathroom Accessories
. . . Enameled Brick . . . Special Shapes

See *Sweets Architectural Catalog, No. 11-5,*
Section 11, Fifth Catalog

KRAFTILE COMPANY
NILES - CALIFORNIA
(San Francisco Bay Area)

THE HERMANN SAFE CO.

MANUFACTURERS AND DEALERS
OF
FIRE AND BURGLAR PROOF
SAFES AND VAULTS, SAFE-
DEPOSIT BOXES, ETC.

200 HOWARD STREET
SAN FRANCISCO
GARfield 3041 - 3042

ROLL-AWAY

OF BERKELEY

WINDOW SCREENS

HAVE NO
EQUAL

A specification leaving no oppor-
tunity for substitution . . . will be
permanently appreciated by
every client.

ROLL-AWAY WINDOW
SCREEN COMPANY
8TH & CARLTON STS., BERKELEY, CALIF.
SAN FRANCISCO 557 MARKET ST.
LOS ANGELES 169 N. LA BREA

FERRO— PORCELAIN

A brilliant and lus-
trous surface, has
an eye appeal sec-
ond to no other
building material.

Store owners,
everywhere are
looking for some-
thing different.

Here it is.

Low in cost—too.

Inquiries promptly answered

FERRO ENAMELING CO.
1100 - 57th Ave., Oakland, Calif.

ANDERSON & RINGROSE

General Contractors

320 Market Street, San Francisco
Phone GARfield 2245

HIGH GRADE MILLWORK
AND INTERIOR FINISH
SASH AND DOORS

LANNOM BROS. MFG. CO.

FIFTH AND MAGNOLIA STREETS
OAKLAND, CALIFORNIA
Telephone: TEmplebar 3663

MULLEN MFG. COMPANY

BANK, STORE AND OFFICE
FIXTURES—CABINET WORK
OF GUARANTEED QUALITY
CHURCH SEATING

Office and Factory:
60-80 RAUSCH ST., Bet. 7th and 8th Sts.
San Francisco
Telephone UNDERhill 5815

G. P. W. JENSEN & SON

Building Construction

320 Market Street, San Francisco
Phone: CAfield 2444

DINWIDDIE CONSTRUCTION COMPANY

BUILDERS OF
GOOD BUILDINGS

CROCKER BUILDING
SAN FRANCISCO

Carl T. Doell Co.

Plumbing
Heating

Plumbing Contractor
Veterans Memorial Building
Oakland

467 21ST STREET
OAKLAND

Telephone CLencourt 8246

A BACHELOR'S PARADISE

One of San Francisco's leading pioneers in decoration, F. Eldon Bauldauf, will decorate the ideal room for a bachelor which will be a part of the decorative arts exhibit at the 1939 Golden Gate International Exposition. Bauldauf won the honor in a competition conducted by the Northern California Division of the American Institute of Decorators in which twenty-seven prominent decorators submitted plans. The contest was judged by the officers of the A.I.D. and by the Exposition's decorative arts committee headed by Dorothy Wright Liebes. Members of the committee, all internationally known for their accomplishments in the decorative arts field included Ernest Amberg, Richard F. Bach, Mrs. Cabot Brown, Mrs. Norman Chandler, Mrs. Walter Dillingham, Mrs. Herbert Fleishacker, Jr., Jean-Michel Frank, Morgan A. Gunst, Miss Frances Heard, Mrs. Roger Lapham, Mrs. Samuel Lewisoohn, Mrs. Charles J. Liebman, Miss Frances McCadden, Grover Magnin, Dr. Elizabeth Moses, Dr. Lila M. O'Neale, Dr. Mary F. Patterson, Mrs. Atherton Richards, Mrs. Joseph B. Sheffield, Mrs. Phillip Spaulding, Mrs. Eldridge Spencer, Mrs. Charles Messer Stower, Mrs. James W. Thorne, Richardson Wright, Miss Grace Alexandra Young, and Miss Margaret McElroy.

The winning room, a combination living-bedroom, combines beauty and utility from a man's viewpoint. The walls will be of pearl gray, accented by heavy burnt-orange drapes. The two outstanding features of the room are its large cathedral window, and a spacious fireplace with a specially invented collapsible screen. Chartreuse green, black, and gold trim will be used as dominating colors in the furniture. The utility highlight of the room is a dressing cabinet with compartments for every piece of apparel and accessories a man might use—including collar buttons, riding boots, and a top hat.

Bauldauf was born in Germany and began his studies in Dresden at the Royal Art School at the age of sixteen. Here he received the basis of his present broad knowledge in the then pioneer field of creative work

COMFORT

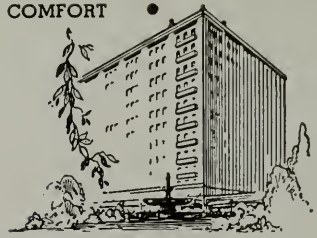

New HOTEL CLARK in Downtown LOS ANGELES

Convenience is another offering of this hotel. Whether on business or pleasure bent, the Hotel Clark makes an ideal "base of operations," as well as a restful "billet" at the end of the day's "campaign." Good Food, naturally. And moderate charges, as well as for room accommodations, give final significance to assuring word — COMFORT

Single from \$2.50
Double from \$3.50

ROOMS
555
BATHS

Fifth and Hill

P. G. B. MORRIS, Manager

Smith

Lumber Company

WHOLESALE - JOBBING - RETAIL

FACTORY AND BUILDING LUMBER

PLYWOODS - ROOFING

DISTRIBUTING YARDS

San Francisco

Oakland

4th & Channel

19th Ave. &

Market 0103

Estuary

Market 0103

FRuitvale 3174

YOUR INQUIRIES SOLICITED

JOSEPH MUSTO SONS-KEENAN COMPANY

MARBLE

and

ONYX

535 NORTH POINT STREET
SAN FRANCISCO
1801 S. SOTO STREET
LOS ANGELES

ABBOT A. HANKS, INC.
Engineers & Chemists

INSPECTING — TESTING — CONSULTING
 CONCRETE • STEEL • MATERIALS
 CHEMICAL AND TESTING
 LABORATORIES

- RESEARCH AND INVESTIGATION •
- TESTS OF STRUCTURAL MATERIALS
- DESIGN OF CONCRETE MIXES
- SHOP AND ERECTION INSPECTION OF
- STRUCTURES AND EQUIPMENT
- INVESTIGATION OF STRUCTURES
- AND MATERIALS
- TESTS AND INVESTIGATION OF
- FOUNDATION SOILS
- FIRE RESISTANCE AND INSULATION
- TESTS

624 Sacramento Street, San Francisco

VAUGHN - G. E. WITT Co.

Manufacturers and Distributors

Pump Governors	Oil Heaters
Safety Pump Governors	Relief Valves
Automatic Gas Regulating Valves	Oil Burner Governors
Gas Burning Equipment	Oil Burners
Vacuum Pump Governors	Oil Pumping Sets
Vacuum Regulating Valves	Oil Valves
Continuous Flow Steam Traps	Oil and Steam Strainers
Thermostats	Duplex Oil Pumps
Reducing Valves	Rotary Oil Pumps
	Boiler Feed Pumps
	Water Heaters
	Boiler Feed-Water Regulators

4224-28 Hollis St., Emeryville, Oakland

Phone GARfield 1164

Hunter & Hudson

Consulting Engineers

DESIGNERS OF HEATING
 AIR CONDITIONING
 VENTILATING AND WIRING
 SYSTEMS, MECHANICAL
 AND ELECTRICAL EQUIP-
 MENT OF BUILDINGS

41 SUTTER STREET
 ROOM 710

San Francisco California

OVER NIGHT OR JUST A MEAL



SANTA MARIA INN

FRANK J. McCoy, Manager

On the Coast Highway, midway between
 San Francisco and Los Angeles

which laid stress on observation and direct contact with nature instead of resorting to the work left by the past. His study itinerary included the better known schools and museums of Munich, Duesseldorf, Paris, Rome and Florence.

CAN "TAKE IT"

Man-made machinery's ability to "take it" was dramatically demonstrated recently when a 25 horsepower air conditioning compressor unit withstood the intense heat of a ravaging fire, and yet was put in operating condition simply by cleaning it and reconnecting it to the proper lines.

Hundreds of firemen battled for more than three hours to control a fire in the William Hahn & Company shoe store in Washington, D. C.

Down in the basement of the store, workers discovered a Westinghouse Sealless 25 horsepower condensing unit, the "heart" of the store's air conditioning system. Part of a crumbled wall had fallen on it, shearing off power and water supply connections. The main floor had collapsed, showering the unit with scorching embers and heavy beams. Tons of water, poured into the inferno from firemen's hose lines, had nearly submerged it.

A thorough examination revealed that the only action necessary to put the unit back in operating condition was to clean it thoroughly on the exterior parts with an iron brush, and connect new copper lines to it. The heat of the fire was so great that it melted the copper tubing running to and from the unit. With a good exterior cleaning and some new copper tubing the unit was quickly placed in operating condition.

**FINE WATER COLORS
 AND PAPERS
 FOR ARCHITECTURAL
 RENDERINGS**

**H. S. CROCKER
 COMPANY, Inc.**

720 MISSION STREET
 MARKET STREET AT SECOND
 SAN FRANCISCO

Looking for something that will stand the gaff in

BAKERIES
BREWERIES
DAIRIES

RENOLIN

an Alkyd Resin Enamel for top coat is the answer.

FRANK W. DUNNE CO.
 41st and Linden Sts. Oakland, Calif.
MAKERS OF GOOD PAINT

REPUBLIC STEEL CORPORATION



Manufacturers of

ENDURO Stainless Steel; TON-CAN Copper Molybdenum Iron Sheets and Pipe; and Steel Pipe, Sheets and Reinforcing Bar for every building purpose.

Write for information

Rialto Building, San Francisco, Calif.
 Edison Building, Los Angeles, Calif.
 White-Henry-Stuart Bldg., Seattle, Wash.

JOHN CASSARETTO

—Since 1886—And Still Active—

Building Materials

READY MIX CONCRETE
 ROCK - SAND - GRAVEL - LIME
 CEMENT - PLASTER - MORTAR
 METAL LATH - WOOD LATH
 STUCCO - WIRE NETTING

Service Unexcelled

Bunkers
 Sixth and Channel, San Francisco
 Phones: GARfield 3176, GARfield 3177

THE TORMEY COMPANY

GENERAL PAINTERS
 AND DECORATORS

Phone UNDERhill 1913

563 FULTON STREET
 San Francisco

ARCHITECTS' AND ENGINEERS' SPECIFICATION INDEX

Classified Directory of Building Material Manufacturers, Dealers and Contractors

*Denotes subscriber of ARCHITECTS' REPORTS, sponsored and endorsed by State Association of California Architects, and published daily by THE ARCHITECT AND ENGINEER.

Acoustical and Sound Control
STRONG CORK PRODUCTS Co., 1355 Market Street, San Francisco.

OHNS-MANVILLE Sales Corp., 116 New Montgomery Street, San Francisco.

STERN ASBESTOS Co., 675 Townsend Street, San Francisco.

AMER Co., 50 Howard Street, San Francisco.

RNER RESILIENT FLOORS, Inc., 141 New Montgomery Street, San Francisco.

LOTEX Corp., 675 Townsend Street, San Francisco.

AIR CONDITIONING

T. JOHNSON Company, 940 Arlington, Oakland.

ELECTRIC APPLIANCES, Inc., 2001 Van Ness Avenue, San Francisco.

LADDIN HEATING Corporation, 5107 Broadway, Oakland.

RANK EDWARDS Co. (General Electric), 930 Van Ness Avenue, San Francisco.

GENERAL Air Conditioning & Heating Company, 4001 Piedmont Avenue, Oakland.

ARCHITECTURAL METAL SUPPLIES

RAUN-STEELP Co., 636 Potrero Ave., San Francisco.

ARCHITECTURAL TERRA COTTA

CLARK & SONS, 116 Natoma Street, San Francisco.

LADDIN McBEAN & Co., 9th and Harrison Streets, San Francisco; 2901 Los Feliz Boulevard, Los Angeles; 1500 First Avenue South, Seattle; 79 S. E. Taylor Street, Portland; 22nd and Market Streets, Oakland; 1101 N. Monroe Street, Spokane; Vancouver, B.C.

ARTILE COMPANY, Niles, California, and 525 Market Street, San Francisco.

BATHROOM HEATERS

ESIX ELECTRIC Heater Company, 390 First Street, San Francisco; 631 San Julian Street, Los Angeles; 2008 Third Avenue, Seattle, Wash.

BLINDS—VENETIAN

JUN-CARLE & Co., 20 Potrero Avenue, San Francisco.

L. E. ROOT, 1865 California Street, San Francisco.

Y-LOCK Co., 1355 Market Street, San Francisco.

BOILERS AND PIPE

C. MOORE & Company, 450 Mission Street, San Francisco.

BRICK—FACE, COMMON, ETC.

CLARK & SONS, 116 Natoma Street, San Francisco.

LADDIN McBEAN & Co., 9th and Harrison Streets, San Francisco; 2901 Los Feliz Boulevard, Los Angeles; 1500 First Avenue, South, Seattle; 79 S.E. Taylor Street, Portland; 22nd and Market Streets, Oakland; 1102 N. Monroe Street, Spokane; Vancouver, B.C.

BRASS

AMERICAN BRASS Co., Russ Building, San Francisco.

BUILDERS HARDWARE

E STANLEY WORKS, New Britain, Conn.; Monadnock Bldg., San Francisco; Los Angeles and Seattle.

CHLAGE LOCK Co., 20 Blanken Avenue, San Francisco.

ARMER'S UNION, 151 W. Santa Clara Street, San Jose.

AXWELL HARDWARE Company, 1320 Washington Street, Oakland.

and F. CORBIN, New Britain, Conn.

BUILDING MATERIALS

UILDING MATERIAL EXHIBIT, Architect's Building, Los Angeles.

ELROSE BUILDING MATERIAL CO., 4501 Tidewater Avenue, Oakland.

*CONTRA COSTA BUILDING MATERIALS Company, 2824 Shattuck Ave., Berkeley.

*MISSION BUILDING MATERIALS Co., Millbrae, Calif.

*RHODES & KENNEDY, 101 4th Street, Oakland.

BUILDING PAPERS

THE SISALKRAFT Company, 205 W. Wacker Drive, Chicago, Ill., and 55 New Montgomery Street, San Francisco.

BUILDING PRODUCTS

"BASALITE," a lightweight, pre-fabricated material for floors, walls and roofs—Basalt Rock Co., Inc., Napa, California.

CABINET WORK

*FINK and SCHINDLER, 552 Brannan Street, San Francisco.

MULLEN MANUFACTURING Co., 64 Rausch Street, San Francisco.

*MODERN FIXTURE & Cabinet Co., 59 Oak Grove Street, San Francisco.

CEMENT

*CALAVERAS CEMENT Company, 315 Montgomery Street, San Francisco.

PORTLAND CEMENT Association 564 Market Street, San Francisco; 816 West Fifth Street, Los Angeles; 146 West Fifth Street, Portland; 518 Exchange Building, Seattle.

"GOLDEN GATE" and "OLD MISSION" manufactured by Pacific Portland Cement Co., 111 Sutter Street, San Francisco; Portland, Los Angeles and San Diego.

*HENRY COWELL Lime & Cement Company, 2 Market Street, San Francisco.

*SANTA CRUZ PORTLAND Cement Company, Crocker Building, San Francisco.

CEMENT—COLOR

"GOLDEN GATE TAN CEMENT" manufactured by Pacific Portland Cement Co., 111 Sutter Street, San Francisco; Portland, Los Angeles and San Diego.

CEMENT PAINT

FRANK W. DUNNE Company, 41st and Linden Streets, Oakland.

CHEMICAL ENGINEERS

ABBOT A. HANKS, Inc., 624 Sacramento Street, San Francisco.

ROBERT W. HUNT, 251 Kearny Street, San Francisco.

CLAY PRODUCTS

GLADDING McBEAN & Company, San Francisco, Los Angeles, Portland and Seattle.

N. CLARK & SON, San Francisco and Los Angeles.

KRAFTILE Company, Niles, California, and 525 Market St., San Francisco.

*GLADDING BROS. Mfg. Co., San Jose.

CLOCKS—ELECTRIC TIME

*INTERNATIONAL BUSINESS Machines Corp., 25 Battery Street, San Francisco.

CONCRETE AGGREGATES

GOLDEN GATE ATLAS Material Company, Sixteenth and Harrison Streets, San Francisco.

JOHN CASSARETTO, Sixth and Channel Streets, San Francisco.

*TRANSIT CONCRETE, Inc., 2500 Peralta Street, Oakland.

CONCRETE CURING & PROTECTION

THE SISALKRAFT Company, 205 W. Wacker Drive, Chicago, Ill., and 55 New Montgomery Street, San Francisco.

CONTRACTORS—GENERAL

LINDGREN & SWINERTON, Inc., Standard Oil Building, San Francisco.

DINWIDDIE CONSTRUCTION Co., Crocker Building, San Francisco.

CLINTON CONSTRUCTION Company, 923 Folsom Street, San Francisco.

ANDERSON & RINGROSE, 320 Market Street, San Francisco.

G. P. W. JENSEN, 320 Market Street, San Francisco.

*GEO. ARTHUR & SON, 941 So. Claremont Street, San Mateo.

*A. T. BECKETT, 224 Scenic Avenue, Piedmont.

*L. M. G. PETERSON, 520 Bowdoin Street, Palo Alto.

*BARRETT & HILP, 918 Harrison Street, San Francisco.

DAMP-PROOFING & WATERPROOFING

"GOLDEN GATE TAN PLASTIC Water-proof Cement," manufactured by Pacific Portland Cement Co., 111 Sutter Street, San Francisco; Portland, Los Angeles and San Diego.

DOOR HANGERS

PITCHER'S SLIDING DOOR HANGERS, Sheldon Building, San Francisco.

DOORS—HOLLOW METAL

FORDERER CORNICE Works, Potrero Ave nue, San Francisco.

KAWNEER Mfg. Co., Eighth Street and Dwight Way, Berkeley.

ACID PROOF DRAIN PIPE

CORROSION—ACID resisting pipe, fittings exhaust fans, pumps, etc., Pacific Foundry Co., 3100 19th Street, San Francisco

1400 S. Alameda Street, Los Angeles.

DRINKING FOUNTAINS

HAWS DRINKING FAUCET Co., 1808 Harmon Street, Berkeley; American Seating Co., San Francisco, Los Angeles and Phoenix.

ELECTRIC ADVICE

PACIFIC COAST ELECTRICAL Bureau, 447 Sutter Street, San Francisco, and 601 W Fifth Street, Los Angeles.

ELECTRIC FIXTURES

*THE FRINK Corporation, 557 Market Street, San Francisco.

ELECTRICAL CONTRACTORS

*ALTA ELECTRIC and Mechanical Company 467 O'Farrell Street, San Francisco

ELECTRICAL EQUIPMENT—SUPPLIES

*TRUMBULL ELECTRIC Mfg. Co., 260 Van Ness Avenue, San Francisco.

*GENERAL ELECTRIC Supply Corp., 1201 Bryant Street, San Francisco.

*NATIONAL ELECTRIC Products Co., 400 Potrero Avenue, San Francisco.

*WESTINGHOUSE ELECTRIC & Mfg. Co., 1 Montgomery Street, San Francisco.

ELEVATORS

*WESTINGHOUSE ELECTRIC Elevator Company, 1 Montgomery Street, San Francisco.

*OTIS ELEVATOR Company, Beach Street, San Francisco.

ENAMELING—PORCELAIN

FERRO ENAMELING Company, 1100 57th Street, Oakland.

FLOORING

ASPHALT TILE, Western Asbestos Company, 675 Townsend Street, San Francisco.

*JOHNS-MANVILLE Sales Corp., 116 New Montgomery Street, San Francisco.

MAPLE FLOORING MANUFACTURERS ASSOCIATION, McCormick Building, Chicago. Ask your lumber dealer.

LE ROY OLSON COMPANY, 3070 - 17th Street, San Francisco.

*LILLY & CROWLEY, 123 Kansas Street, San Francisco.

FIXTURES—BANK, OFFICE, STORE

MULLEN MANUFACTURING Co., 64 Rausch Street, San Francisco.

PACIFIC MANUFACTURING Company, 454 Montgomery Street, San Francisco, 1315 Seventh Street, Oakland, Los Angeles and Santa Clara.

ARCHITECTS' AND ENGINEERS' SPECIFICATION INDEX

Classified Directory of Building Material Manufacturers, Dealers and Contractors

*Denotes subscriber of ARCHITECTS' REPORTS, sponsored and endorsed by State Association of California Architects, and published daily by THE ARCHITECT AND ENGINEER.

FURNITURE

- *ALLIED ART GUILD, Menlo Park.
- *PENN. FURNITURE Shops, Inc., 130 Second Avenue, San Mateo.

GAS BURNERS

- VAUGHN-G. E. WITT Company, 4224-28 Hollis Street, Emeryville, Oakland.

GLASS

- W. P. FULLER & Co., 301 Mission Street, San Francisco. Branches and dealers throughout the West.
- LIBBEY-OWENS-FORD GLASS Co., Toledo, Ohio; 633 Rialto Building, San Francisco; 1212 Architect's Building, Los Angeles; 550 Skinner Building, Seattle.
- PITTSBURGH PLATE GLASS Company, Grant Building, Pittsburgh, Pa. W. P. Fuller & Co., Pacific Coast Distributors.
- *L. H. BUTCHER COMPANY, Fifteenth and Vermont Sts., San Francisco.
- *EAST BAY GLASS Company, 621 Sixth Street, Oakland.
- *COBBLEDICK-KIBBE GLASS Company, San Francisco and Oakland.

HEATING—ELECTRIC

- WESIX ELECTRIC Heater Company, 390 First Street, San Francisco; 631 San Julian Street, Los Angeles; 2008 Third Avenue, Seattle, Wash.

HEATING—GAS

- PACIFIC GAS & ELECTRIC Co., 245 Market Street, San Francisco.
- GENERAL Air Conditioning & Heating Company, 4001 Piedmont Avenue, Oakland.
- HARER-PERRY Co., 5662 Keith Avenue, Oakland.
- *W. H. PICARD, Inc., 4166 Broadway, Oakland.
- *ALADDIN HEATING Corp., 22d and San Pablo Avenue, Oakland.

HEATING—OIL

- S. T. JOHNSON Company, 940 Arlington, Oakland.

HEAT GENERATORS

- *WATROLO CORPORATION, LTD., 1170 Howard Street, San Francisco.

HEATING & VENTILATING EQUIPMENT

- *AMERICAN RADIATOR Company, 4th and Townsend Streets, San Francisco.

HEAT REGULATION

- JOHNSON SERVICE Company, Milwaukee, represented on the Pacific Coast by the following branch offices: 814 Rialto Bldg., San Francisco; 153 West Avenue, 34, Los Angeles; 1312 N.W. Raleigh Street, Portland, and 473 Coleman Bldg., Seattle.

HOLLOW BUILDING TILE (Burned Clay)

- N. CLARK & SONS, 116 Natoma Street, San Francisco.
- GLADDING McBEAN & Co., 9th and Harrison Streets, San Francisco; 2901 Los Feliz Boulevard, Los Angeles; 1500 First Avenue South, Seattle; 79 S.E. Taylor Street, Portland; 22nd and Market Street, Oakland; 1102 N. Monroe Street, Spokane; Vancouver, B.C.
- KRAFTILE Company, Niles, California, and 525 Market Street, San Francisco.

HOTEL AND RESTAURANT EQUIPMENT

- *DOHRMANN HOTEL SUPPLY Company, 973 Mission Street, San Francisco.

INSPECTION AND TESTS

- ABBOT A. HANKS, Inc., 624 Sacramento Street, San Francisco.
- ROBERT W. HUNT Co., 251 Kearny Street, San Francisco.

INSULATION

- CELOTEX Corp., 675 Townsend Street, San Francisco.
- *JOHNS-MANVILLE Sales Corp., 116 New Montgomery Street, San Francisco.
- WESTERN ASBESTOS Co., 675 Townsend Street, San Francisco.
- CABOT'S QUILT—Gunn, Carle & Co., 20 Potrero Avenue, San Francisco.
- VAPORSEAL, Mfg. by Celotex Corp., 919 N. Michigan Avenue, Chicago.
- FIRTEX of Northern California, 461 Market Street, San Francisco.
- *GEORGE D. KARSCH, Builders Exchange, Sacramento, California.

INSURANCE

- *FIREMAN'S FUND Insurance Company, 401 California Street, San Francisco.

INTERIOR DECORATORS

- *REED DRAPERY SERVICE, 440 Post Street, San Francisco.
- *M. H. WALES, 1933 Loguna Street, San Francisco.
- *BETTY KENDALL, 251 Post Street, San Francisco.

KITCHEN EQUIPMENT

- *MANGRUM, HOLBROOK & ELKUS, 301 Golden Gate Avenue, San Francisco.
- DOHRMANN HOTEL SUPPLY CO., 972 Mission Street, San Francisco.

LACQUERS

- W. P. FULLER & Co., 301 Mission Street, San Francisco. Branches and dealers throughout the West.

LIGHTING FIXTURES

- *W. W. WARREN Company, 955 Mission Street, San Francisco.
- *INCANDESCENT SUPPLY Company, 726 Mission Street, San Francisco.
- *PHOENIX-DAY Company, 729 Mission Street, San Francisco.

LIMESTONE

- *INDIANA LIMESTONE Company, 130 Lunado Way, San Francisco.

LINOLEUM, CARPETS, Etc.

- *WEST COAST LINOLEUM & CARPET Co., 1163 Market Street.
- *VAN FLEET-FREAR Company, 557 Howard Street, San Francisco.
- TURNER RESILIENT FLOORS, Inc., 141 New Montgomery Street, San Francisco.
- *D. N. & E. WALTER & Company, 562 Mission Street, San Francisco.
- *CONGOLEUM-NAIRN, Inc., 1355 Market Street, San Francisco.

LOCKERS—METAL

- *TRASK & SQUIER, 39 Natoma Street, San Francisco.

LUMBER

- PACIFIC MFG. Co., 454 Montgomery Street, San Francisco; 1315 Seventh Street Oakland; Los Angeles and Santa Clara.
- SMITH LUMBER Company, Nineteenth Avenue and Estuary, Oakland.
- MELROSE LUMBER & SUPPLY Co., Forty-sixth Avenue and E. Twelfth Street, Oakland.
- E. K. WOOD LUMBER Company, 4701 Santa Fe Avenue, Los Angeles; 1 Drumm Street, San Francisco; Frederick and King Streets, Oakland.
- *SANTA FE LUMBER Company, 16 California Street, San Francisco.
- FRIEND & TERRY LUMBER Co., Front & S Streets, Sacramento.
- *OAKLAND LUMBER Co., 6901 E. 14th Street, Oakland.

MACHINERY—PUMPS, Etc.

- SIMONDS MACHINERY Company, 816 Folsom Street, San Francisco.

MARBLE

- JOSEPH MUSTO SONS-KEENAN Co., 535 N. Point Street, San Francisco.

MILLWORK

- E. K. WOOD LUMBER Company, No. Drumm Street, San Francisco, Oakland, Los Angeles.
- LANNOM BROS. Mfg. Co., Fifth and Mariposa Streets, Oakland.
- MELROSE LUMBER & SUPPLY Company, Forty-sixth Avenue and E. Twelfth Street, Oakland.
- PACIFIC MFG. Co., 454 Montgomery Street, San Francisco; 1315 Seventh Street, Oakland; Los Angeles and Santa Clara.
- SMITH LUMBER Company, Nineteenth Avenue and Estuary, Oakland.
- *WESTERN DOOR and SASH Company, 5th and Cypress Streets, Oakland.
- *OAKLAND PLANING MILL, 105 Westington Street, Oakland.
- *T. P. HOGAN Company, 2d and Alameda Streets, Oakland; 630 Mission Street, San Francisco.
- *SAN MATEO PLANING MILL, San Mateo.

MONEL METAL

- "INCO" BRAND, distributed on the Pacific Coast by the Pacific Metals Company, 3100-19th Street, San Francisco, and 140 So. Alameda Street, Los Angeles.
- *WHITEHEAD METAL APPLIANCE CO., 4238 Broadway, Oakland.

NURSERY STOCK

- *C. J. BURR, 305 Lytton Avenue, Palo Alto.
- *CALIFORNIA NURSERIES, Niles.

OIL BURNERS

- *SAN MATEO FEED and FUEL Company, San Mateo, Cal.
- S. T. JOHNSON Co., 585 Potrero Avenue, San Francisco; 940 Arlington Street, Oakland; 1729 Front Street, Sacramento, and 1020 El Camino Real, San Carlos, Calif.
- VAUGHN-G. E. WITT Co., 4224-28 Hollis Street, Emeryville, Oakland.
- *HORABIN OIL & BURNER Company, 23 Hamilton Avenue, Palo Alto.
- PAN-AMERICAN SIMPLEX OIL BURNER, 820 Parker Street, Berkeley.

ONYX

- JOSEPH MUSTO SONS-KEENAN Co., 535 N. Point Street, San Francisco.

ORNAMENTAL IRON

- INDEPENDENT IRON WORKS, 821 Pine Street, Oakland.

PAINTING, DECORATING, Etc.

- THE TORMEY Co., 563 Fulton Street, San Francisco.
- *RAPHAEL Company, 270 Tehama Street, San Francisco.

PAINTS, OIL, LEAD

- W. P. FULLER & Co., 301 Mission Street, San Francisco. Branches and dealers throughout the West.
- FRANK W. DUNNE Co., 41st and Linden Streets, Oakland.

- NATIONAL LEAD Company, 2240-24th Street, San Francisco. Branch dealers in principal Coast cities.

- *SHERWIN-WILLIAMS Company, 1415 Sherwin Avenue, Oakland.
- *WALTER N. BOYSEN PAINT CO., 42nd and Linden Street, Oakland

PARTITIONS—MOVABLE OFFICE

- PACIFIC MFG. Co., 454 Montgomery Street, San Francisco; 1315 Seventh Street Oakland; factory at Santa Clara.

PLASTER

- "EMPIRE" and "RENO HARDWARE PLASTER," manufactured by Pacific Portland Cement Co., 111 Sutter Street, San Francisco; Portland, Los Angeles and San Diego.

ARCHITECTS' AND ENGINEERS' SPECIFICATION INDEX

Classified Directory of Building Material Manufacturers, Dealers and Contractors

*Denotes subscriber of ARCHITECTS' REPORTS, sponsored and endorsed by State Association of California Architects, and published daily by THE ARCHITECT AND ENGINEER.

PLASTERING CONTRACTOR
AMES F. SMITH, 271 Minna Street, San Francisco.

PLASTER—ACOUSTICAL
LACOUSTIC, Sound Absorbing Plaster, manufactured by Pacific Portland Cement Co., 111 Sutter Street, San Francisco, Los Angeles and San Diego.

PLASTER MATERIALS
S. GYPSUM Company, Architect's Building, Los Angeles.

PLATE GLASS
BEY-OWENS-FORD GLASS Co., Toledo, Ohio; 633 Rialto Building, San Francisco; 1212 Architect's Building, Los Angeles; Mr. C. W. Holland, P.O. Box 3142, Seattle.

PLUMBING CONTRACTORS
L. T. DOELL, 467-21st Street, Oakland.
COTT Company, 243 Minna Street, San Francisco.

J. H. PICARD, 4166 Broadway, Oakland.

PLUMBING FIXTURES AND SUPPLIES
LANE Co., all principal Coast cities.
STANDARD SANITARY Manufacturing Company, 278 Post Street, San Francisco.
WALWORTH CALIFORNIA Company, 565 Sixth Street, San Francisco.
V. R. AMES Co., 150 Hooper Street, San Francisco.
Y-HOLBROOK, Inc., 165 Eighth Street, San Francisco.

PRESSURE REGULATORS
LUGHN-G. E. WITT Co., 4224-28 Hollis Street, Emeryville, Oakland.

PUMPS
MONDS MACHINERY Company, 816 Folsom Street, San Francisco.

REFRIGERATION
LCO-FRIGIDAIRE ELECTRIC REFRIGERATORS, Aladdin Heating Corp., 22d and Broadway, Oakland.

ROOFING CONTRACTORS
MALLOTT & PETERSON, 2412 Harrison Street, San Francisco.

ROOFING INSULATION
OHNS-MANVILLE Sales Corp., 116 New Montgomery Street, San Francisco.

ROOF MATERIALS
OHNS-MANVILLE Sales Corp., 116 New Montgomery Street, San Francisco.
PIONEER FLINTKOTE Company, Shell Building, San Francisco.

ARAFFINE Company, Inc., 475 Brannan Street, San Francisco.

LADDING McBEAN & Co., 9th and Harrison Streets, San Francisco; 2901 Los Feliz Boulevard, Los Angeles; 1500 First Avenue South, Seattle; 79 S.E. Taylor Street, Portland; 22nd and Market Street, Oakland; 1102 N. Monroe Street, Spokane; Vancouver, B.C.
MARSHALL SHINGLE Company, 608-16th Street, Oakland.

CLARK & SONS, 112-116 Natoma Street, San Francisco; works, West Alameda.
CERTAIN-TEED PRODUCTS Co., 315 Montgomery Street, San Francisco.

SAFES
ERRING-HALL-MARVIN SAFE Co., 214 California Street, San Francisco.

SAND, ROCK AND GRAVEL
OHN CASSARETTO, Sixth and Channel Streets, San Francisco.
SALT ROCK Co., Napa.

HAISER PAVING Company, Latham Square Building, Oakland.
ELROSE BUILDING MATERIAL Co., 4501 Tidewater Avenue, Oakland.

SCREENS
ROLL-AWAY WINDOW SCREEN Company, Eighth and Carlton Streets, Berkeley; 557 Market Street, San Francisco.

SEATING
*HEYWOOD-WAKEFIELD Co., 180 New Montgomery Street, San Francisco.
*GENERAL SEATING Company, 160 Second Street, San Francisco.

SHADE CLOTH
CALIFORNIA SHADE CLOTH Co., 210 Bayshore Boulevard, San Francisco.

SHINGLE STAINS
CABOT'S CREOSOTE STAINS, Gunn-Carle & Co., 20 Potrero Ave., San Francisco.

AUTO SPRINKLERS
GLOBE AUTOMATIC SPRINKLER Co., 665-6th Street, San Francisco.

STANDARD STEEL BUILDINGS
INDEPENDENT IRON WORKS, 821 Pine Street, Oakland.

STEEL FURNITURE
*GENERAL FIREPROOFING Company, 160 Second Street, San Francisco.

STEEL—REINFORCING
*SOULE STEEL Company, Army Street, San Francisco and Los Angeles.
GUNN-CARLE Company, Portrero Avenue San Francisco.

CECO STEEL PRODUCTS Co., 1280 Indiana Street, San Francisco.

*W. C. HAUCK & Co., 280 San Bruno Avenue, San Francisco.
*TRUSCON STEEL Company, 604 Mission Street, San Francisco.

STEEL—STAINLESS
REPUBLIC STEEL Corporation, Rialto Building, San Francisco; Edison Building, Los Angeles; White-Henry-Stuart Building, Seattle.

STEEL—STRUCTURAL
INDEPENDENT IRON WORKS, 821 Pine Street, Oakland.
JUDSON PACIFIC Company, C. F. Weber Building, Mission and Second Streets; San Francisco shops, San Francisco and Oakland.

HERRICK IRON WORKS, 18th and Campbell Streets, Oakland.

*MOORE DRYDOCK Company, Foot of Adeline Street, Oakland.

*WESTERN IRON WORKS, 141 Beale Street, San Francisco.
COLUMBIA STEEL Company, Russ Building, San Francisco.

STORE FIXTURES
MULLEN MFG. Co., 60 Rausch Street, San Francisco.

STORE FRONTS
ZORI STORE FRONTS, Niles, Michigan.
KAWNEER MFG. Co., Eighth Street and Dwight Way, Berkeley.

STUCCO NETTING—WELDED
"WELDWEAVE," E. H. EDWARDS CO., 200 Bush Street, San Francisco; 620 E. 61st Street, Los Angeles; 1252 6th Avenue S., Seattle; 2690 N.W. Nicolai Street, Portland.

TEMPERATURE REGULATION
JOHNSON SERVICE Company, Milwaukee, represented on the Pacific Coast by the following branch offices: 814 Rialto Building, San Francisco; 153 West Avenue, 34, Los Angeles; 1312 N.W. Raleigh Street, Portland, and 473 Coleman Building, Seattle.

TELEPHONES—INTERCOMMUNICATING
*PACIFIC TELEPHONE and TELEGRAPH Company, 140 New Montgomery Street, San Francisco.

TERMITE CONTROL—WOOD PRESERVATIVE
E. K. WOOD LUMBER Company, No. 1 Drumm Street, San Francisco; 4701 Santa Fe Avenue, Los Angeles; Frederick and King Streets, Oakland.
J. H. BAXTER & COMPANY, 333 Montgomery Street, San Francisco.

TILE—DECORATIVE, Etc.
*CAMBRIDGE TILE Mfg. Co., 1155 Harrison Street, San Francisco.

POMONA TILE MFG. Co., plant, Pomona, Cal.; Sales Rooms, 135 Tenth Street, San Francisco; 217 S. La Brea Avenue, Los Angeles; 6106 Roosevelt Way, Seattle.
GLADDING McBEAN & Co., 9th and Harrison Streets, San Francisco; 2901 Los Feliz Boulevard, Los Angeles.

KRAFTILE Company, Niles California, and 525 Market St., San Francisco.
*CALIFORNIA ART TILE Corp., Richmond, Cal.

TREE SURGERY
DAVEY TREE SURGERY Co., Ltd., Russ Building, San Francisco; Story Building, Los Angeles.

TRUSSES
*SUMMERBELL TRUSS Company, 405 Builders Exchange Building, Oakland.
*ARCH-RIB TRUSS Company, 608 Sixteenth Street, Oakland.

VALVES
"KRAMER" Flush Valves, MacDonald Hardware Manufacturing Co., 963 Harrison Street, San Francisco.

SLOAN VALVE Company, Chicago, Ill
SHAND AND JURS Co., Eighth and Carlton Streets, Berkeley.

VARNISHES
NATIONAL LEAD Company, 2240-24th Street, San Francisco. Branches and dealers in all principal Coast cities.
W. P. FULLER Company, San Francisco and principal Coast cities.

FRANK W. DUNNE Co., 41st and Linden Streets, Oakland.

VAULTS AND SAFES
HERMANN SAFE Company, 200 Howard Street, San Francisco.

VENTILATING EQUIPMENT
*THE B. F. STURTEVANT Company, 759 Monadnock Building, San Francisco

WALL BOARD
*WESTERN BUILDERS SUPPLY Company, 401 Fourth Street, San Francisco.

WATER HEATERS—GAS AND ELECTRIC
*WATROLA Corporation, Ltd., 1170 Howard Street, San Francisco.

*PITTSBURGH WATER HEATER Co., 898 Van Ness Avenue, San Francisco.
*RUUD HEATER Company, 437 Sutter Street, San Francisco.

WESIX ELECTRIC HEATER Company, 380 First Street, San Francisco.

WINDOW SASH AND FIXTURES
"DALMO," SIMPLEX and "HAUSER" Casement Windows, MacDonald Hardware Mfg. Co., 963 Harrison Street, San Francisco.

*DETROIT STEEL PRODUCTS Co., 111 Sutter Street, San Francisco.

KAWNEER MFG. Company, Dwight Way and Eighth Street, Berkeley.
UNIVERSAL WINDOW COMPANY, (Donovan) 950 Park Street, Berkeley.

WINDOW SHADES
AEROSHADE Company, represented by W. R. Knight, 557 Market Street, San Francisco.
CALIFORNIA SHADE CLOTH Co., 210 Bayshore Boulevard, San Francisco.

INDEX TO ADVERTISEMENTS

*Indicates Alternate Months

A		K	
ALADDIN Heating Corp.	67	KAWNEER Company	*
AMERICAN Brass Company	10	KRAFTILE Company	74
ANDERSON & Ringrose	74		
ARCHITECTS Building	70	L	
B		LANNOM Bros. Manufacturing Company	74
BASALT Rock Company	71	LIBBEY, Owens, Ford Glass Company	4
BAXTER & Company, J. H.	68	LINDGREN & Swinerton, Inc.	69
BUILDING Material Exhibit	70	M	
C		MacDONALD Hardware Manufacturing Company	67
CASSARETTO, John	76	MAPLE Flooring Manufacturers Association	*
CELOTEX Corporation	3rd Cover	MULLEN Manufacturing Company	75
CLARK, N., and Sons	9	MUSTO Sons Keenan Company, Joseph	75
CLINTON Construction Company	74	N	
COLUMBIA Brick Works	70	NATIONAL Lead Company	*
CRANE Company	2	P	
CROCKER First National Bank	73	PACIFIC Coast Gas Association	11
CROCKER, H. S.	76	PACIFIC Coast Electrical Bureau	*
D		PACIFIC Foundry Company, Ltd.	69
DAVEY Tree Surgery Company	71	PACIFIC Manufacturing Company	72
DAY and Night Water Heater Company	72	PACIFIC Portland Cement Company	2nd Cover
DELCO-FRIGIDAIRE	67	PAN-AMERICAN Engineering Co.	73
DINWIDDIE Construction Company	75	PITCHER Company, E. C.	74
DOELL, Carl T., Company	75	PITTSBURGH Plate Glass Company	*
DOUGLAS Fir Plywood Association	6	POMONA Tile	70
DUNNE Company, Frank W.	76	PORTLAND Cement Association	Back Cover
F		R	
FERRO-PORCELAIN Building Co.	74	REPUBLIC Steel Corporation	76
FIRTEX	71	ROLL-AWAY Screen Company	74
FORDERER Cornice Works	73	S	
FULLER Company, W. P.	*	SANTA Maria Inn	76
G		SIMONDS Machinery Company	72
GLADDING, McBean & Company	65	SISALKRAFT Company	72
GOLDEN Gate Atlas Materials Company	72	SLOAN Valve Co.	5
GUNN, Carle & Company	8	SMITH Lumber Company	75
H		STANLEY Works	*
HANKS, Inc., Abbot A.	76	T	
HARER-Perry Company	70	TORMEY Company, The	76
HAWS Drinking Faucet Company	72	U	
HERMANN Safe Company	74	UNIVERSAL Window Company	72
HERRICK Iron Works	73	V	
HOLLEY Manufacturing Co.	70	VANCOUVER Plywood	7
HOTEL CLARK	75	VAUGHAN-G. S. Witt Company	76
HUNT, Robert W. Company	73	W	
HUNTER and Hudson	76	WESIX Electric Heater Company	73
I		WILLAMINA Clay Products Company	68
INCANDESCENT Supply Company	70	WOOD, E. K., Company	66
INDEPENDENT Iron Works	74	WESTERN Asbestos Company	71
J		Z	
JENSEN & Son, G. P. W.	75	ZOURI Store Fronts	*
JOHNSON, S. T., Company	66		
JOHNSON Service Company	*		
JUDSON Pacific Company	71		

HE

ARCHITECT

ND

ENGINEER

AUGUST 1938

Mark Daniels' "Running Fire" — Page 2



Home of Mr. and Mrs. Werner Herold, Berkeley
 Designed by John Hudspeth, Built by J. M. Walker

TAN PLASTIC answered the requirements for this ADOBE TEXTURED WALL

LEADING ARCHITECTS
 SPECIFY IT

★

COMPETENT BUILDERS
 USE IT

★

RELIABLE DEALERS
 HANDLE IT

"In copying the adobe texture of the old Mexican
 houses, we needed a cement that would spread
 and easily, work uniformly under the trowel
 make a watertight wall.

"Pacific Portland Cement Company's 'Tan Plastic'
 answered all our requirements on this home."

{Signed} J. M. Walker, Builder



Rightly Used, It Never Disappoints

PACIFIC PORTLAND CEMENT COMPANY

SAN FRANCISCO • LOS ANGELES

COASTWIDE SERVICE

PORTLAND •

The AUGUST 1938

ARCHITECT & ENGINEER

Fred W. Jones, Editor

Mark Daniels, A. I. A., Associate Editor

Edgar N. Kierulff, Assistant Editor

CONSULTING BOARD OF EDITORS

Architectural—

Arthur Brown, Jr.
Frederick H. Meyer
Timothy L. Pflueger
Will G. Corlett
Harry Michelsen
Lewis P. Hobart
David C. Allison
Gordon B. Kaufmann
Harris C. Allen

Engineering—

H. J. Brunner
L. H. Nishkian
William Adrian
Wm. H. Popert
Homer N. Hadley
John J. Gould
Geo. E. Atkins

Advertising Manager—

J. Leslie Meek

Architects' Reports—

Vernon S. Yallop

THE ARCHITECT AND ENGINEER, INC., 68 Post Street, San Francisco, EXbrook 7182. President, K. P. Kierulff; vice-president, Frederick W. Jones; secretary, L. B. Penhorough. Los Angeles office, 832 W. Fifth Street. Published on the 12th on each month. Entered as second class matter, November 2, 1905, at the Postoffice at San Francisco, California, under the Act of March 3, 1897. Subscriptions, United States and Pan America, \$3.00 a year; Foreign countries, \$5.00 a year; single copy, \$.50.

Contents

FRONTISPIECE

CENTRAL TOWER, SAN FRANCISCO
Albert F. Roller, Architect

TEXT

OLD FASHIONED GARDENS	6
Berniece Ashdown	
CENTRAL TOWER—A NEW NOTE IN SAN FRANCISCO'S SKYLINE	15
STRUCTURAL PROBLEMS OF CENTRAL TOWER	17
H. J. Brunner, C. E.	
DIARY REVEALS INSIGHT INTO EARLY AMERICAN ARCHITECTURE	24
ALONG THE MISSISSIPPI	25
Harry M. Michelsen, A. I. A.	
NEW RACING PLANT, LOS ANGELES	28
ARCHITECTURE — A PROFESSION	33
Emilio John Di Rienzo	
"WHAT IS THE A. I. A. DOING FOR ME?"	35
Francis P. Sullivan	
BETTER AND SAFER HOME OWNERSHIP	41
John H. Fahey	
CONSTRUCTION OF MOUNTAIN HIGHWAYS	45
Ernest McGaffey	
WORLD'S FAIR BUILDERS — LEWIS P. HOBART	48
STANDARD ACCOUNTING SYSTEM FOR ARCHITECTS	50
Irving F. Morrow, Architect	

PLATES AND ILLUSTRATIONS

HOUSE AT RIO DEL MAR, CALIFORNIA	4
W. E. Schirmer, Architect	
RESIDENCE FOR HENNAH RODAKIEWICZ	10
R. M. Schindler, Architect	
CENTRAL TOWER, SAN FRANCISCO	15 to 21
Albert F. Roller, Architect	
PLANT OF OWENS-ILLINOIS PACIFIC COAST COMPANY, LOS ANGELES	23
Albert F. Roller, Architect	
SKETCHES BY H. M. MICHELSEN, A. I. A.	26-27
HOLLYWOOD RACING PLANT	28-29
Stiles O. Clements, Architect	
BUILDING FOR THE INSURANCE COMPANY OF NORTH AMERICA, SAN FRANCISCO	30
Harry A. Thomsen, Jr., Architect	
SANTA FE TERMINAL, SAN FRANCISCO	32
H. L. Gilman, Architect	
BUILDING FOR DEAN WITTER & CO.	37
Allan G. Siple, Architect	
FIRST CHURCH OF CHRIST, SCIENTIST, BEVERLY HILLS	38-39
CIVIC AUDITORIUM, SANTA CRUZ	40
Mark Daniels, Architect	

RUNNING FIRE

by
MARK DANIELS, A.I.A.

Lucrezia from Nippon

Not all the statements we see in print are lies. No, not all, but it is a pretty good practice to question more than we do. At that, these comments do not begin to touch the field of written expressions of competing architects' opinions of one another.

For a perfect example of twisted truth, born of sweet insouciance and sired by wishful thinking, I have yet to read the equal of an ingenious, but none the less sincere, statement of Samuel H. Wainright, Jr., in his work "Beauty in Japan." After a simple description of the love of the Japanese for all the little things that count he writes, "The Japanese feel that every living thing has a right to its life and are loathe to kill even a common enemy."

A sworn statement that it was published in Shanghai in 1938 would not have helped.

★ ★ ★

Bread on the Waters

It has always been a puzzle to me why like reproduces like. Despite the explanations of the functions of genes, hormones, and the like, I sometimes wonder why a cabbage doesn't reproduce an occasional turnip, although I can clearly understand why a bullet through the brain or a bomb in a crowd might result in death. Yet there are others who see these things in the reverse.

For instance, I have read lately that the United States have sold to Japan over \$6,000,000 worth of death dealing war material during the last six months, followed by the announcement that Washington has rigorously protested the bombing of Chinese cities by the Japanese. Just what should we expect Johnny to do with the nice round rock we give him, when he finds an unbroken, shiny window in a vacant house?

It is all so naive.

★ ★ ★

More Jargon

In a recent daily there appeared the following manful, sturdy denial of what sounded like a bit of slander.

"None of his allegations was true. For sheer prevarications his assertions were obvious figments of an imagination distorted by prejudicial hallucinations that are apparent to the most superficial observer and erstwhile auditor."

Ah! Scintillate, scintillate, diminutive constellation.

★ ★ ★

Back to Normal

Well, it's all over. The annual play in the Bohemian Grove has been shelved in the archives of the club. The river water in the pool is clearing and the gentle sigh of the breeze in the lofty tops of the forest giants is heard again. Crickets are humming on the hillsides, lizards are darting from tree roots and woodpeckers are back at their autumn task.

Haig Patigan has donned his smock, Lewis Hobart was seen yesterday entering his office, George Creel is making appointments, Ed O'Day has a smudge of editorial ink on his nose and I, for one, actually got Tim Pflueger on the telephone.

Whether the closing of the Grove will have any noticeable effect on Jess Stanton's conception of the Exposition color scheme will be learned soon, we hope. Heaven be praised, it is all over.

★ ★ ★

Architects and Doctors

We architects brought it on ourselves, and we got both barrels. There was a time when we never said doors. They were openings. The arrangement of windows was fenestration, a porch was a stoa, an inclined wall was one with a batter, if you please, a corner was an arsis, necking was known only to students of the Roman Doric order and a halo was a nimbus to you.

We went further, until the "Lowells who spoke only to God" were hoydens. Anyone who was presumptuous enough to think of designing, to say less of building, before he could run the gamut of architecture from Abacus to Zoophorus deserved to live in an igloo. Finally many people chose exactly that. People who needed housing swallowed their resentment at our

refusal to state the amount of our fees, and went to others who would. Also, they went whole hog and jumped right over the heads of the architectural polygots into the lap of the contractors. Yes, architecture was once a white collar profession that called for a vocabulary, a book and some art. Now look at the damned thing.

The thought that misery loves company is poor comfort but when we see the drug clerk acting as the medical advisor to more than half the population, it is difficult for us architects to hide a broad grin.

★ ★ ★

What Label?

Let's have done with this Bufanory. The more the question of artistic merit, or the lack of it, is discussed, the further we get from reason or accord. Nor can the question of propriety be settled by argument. The artists who had votes were opposed, while those who thought a mallet was used only in croquet and a chisel was a reduction in price voted for the thing in preponderant number, as usual; and that's that.

The only criticism that seems irrefutable is one of name. If we are going to erect a statue of George V we should endeavor to make it look like him. If we put up a design that looks like a lawn mower with the mumps we might be justified in calling it the "Spirit of George V," but hardly a statue of him. Perhaps St. Francis in cans will inspire incantations, but let us be honest enough to put the right label on it.

SAINT AND CITY

Written on the morning of the St. Francis Commemoration, 1927, by Joseph M. Cumming

while a patient in Saint Francis Hospital, S. F.

His joy-spent youth
Lived out its span,
Ere, in his groping for the Truth,
His inward, Christ-like life began.

Adown the years, his life has been
A call to men, their kind to love—
When he had found the God within,
Expression of the God above.

Take heed, O City, hear in mind
Our care-free, reckless youth has fled;
Now, Duty calls our soul to find
And follow where our Saint has led.

Be OURS the task to show mankind
That tho' we swarm the busy mart,
His precepts, still its pulsing life shall bind—
Our City of the Open Heart!

**THE MOST IMPORTANT
STORE FRONT CON-
STRUCTION PRINCIPLE**

RESILIENCY

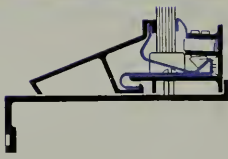

✦ EXTRUDED SASH



★ ROLLED SASH

KAWNEER Store Front construction is not only up-to-date and attractive—it is also efficiently designed to give lasting, trouble-free service. That is why so many prominent architects and builders specify Kawneer Resilient Store Front Sash.

They know that this superior resilient construction allows for the inevitable movement of plate glass, yet holds it in a secure and powerful grip—regardless of variations in thickness. Pressure is distributed evenly along the glass surface. Looseness and rattling are eliminated and the possibilities of glass breakage reduced to an absolute minimum.

Kawneer Store Front Sash is available in either resilient extruded (with a choice of three attractive face pieces) or rolled construction—in either aluminized aluminum or architectural bronze. In addition, the Kawneer line includes complete metal construction such as transom bars, hood, recessed and concealed awning bars, entrance doors, pilasters, mouldings, sign letters and special metal work. Complete information will be sent on request. The Kawneer Company, BERKELEY, CALIF.

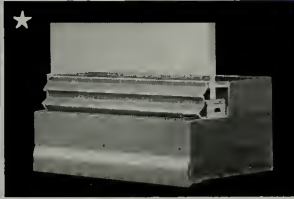
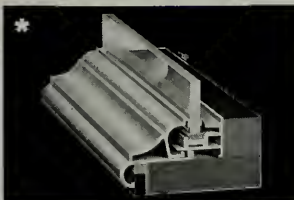
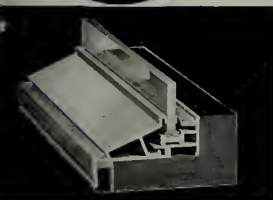

FOUNDED IN 1905—
BY A PRACTICING ARCHITECT

Kawneer

Hustless Metal Store Fronts • Doors • Sealair Windows • Architectural Metal Work
For data see catalogs in SWEET'S, or write The Kawneer Company, at Niles, Michigan, New York, Chicago, or Berkeley, Calif.
Dealers in principal cities.



HOUSE AT RIO DEL MAR, CALIFORNIA
William Edward Schirmer, Architect

TILE LENDS COLOR TO KITCHEN

INTERESTING phases of development of modern kitchens and bathrooms are shown in the new Schirmer dwelling at Rio Del Mar, designed by W. E. Schirmer of Oakland.

The use of tile on the walls of these rooms provides employment of color and affords ease of cleansing. Glass blocks for day light and tubular electric fixtures for artificial light take care of another important problem.

Stove and refrigerator are in recesses which are completely tiled, ceiling-high, with the new 6 x 9 Krafttile. Set in straight joint horizontally, the larger size of tile adds handsome lines to the design as well as the warmth of pleasant color. The attractive shade of rust color of the tile contrasts effectively with the white equipment and blends decoratively with the built-in white cabinets' trim of blue. The floor covering is cream-colored linoleum, mottled with blue and two tints of gray. Baseboard and border of floor covering are of solid blue. The spacious surfaces of the drainboards are of white tile, 6 x 6, diagonal set. Capping is of vitreous tile, also white.

Contrary to usual increased cost of installation for tiles of the larger size, this job was completed at no greater cost per square foot than for tiling of smaller and less attractive size. One phase of economy was the specification of wood moulding at door jambs, thus eliminating cost of tile trim there.

A striking effect was the result of using the window
(Please turn to Column 2, Page 66)

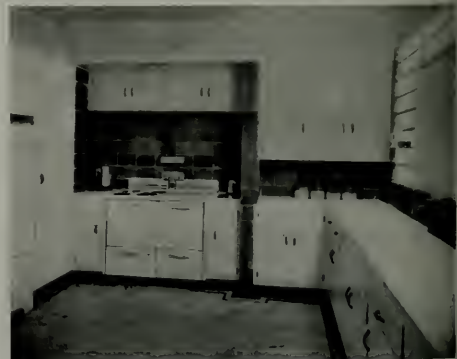
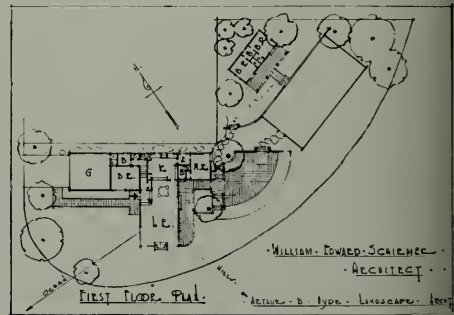

THE KITCHEN—TILED WITH KRAFTILE

THE ARCHITECT AND ENGINEER

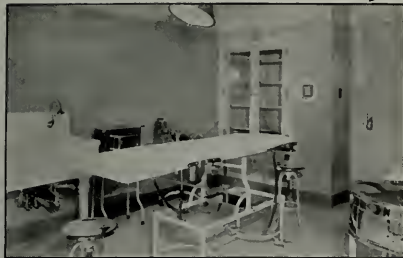

Minor Operating Room, St. Elizabeth's Hospital, Chicago, Ill. Herman J. Gaul & Son, Architects

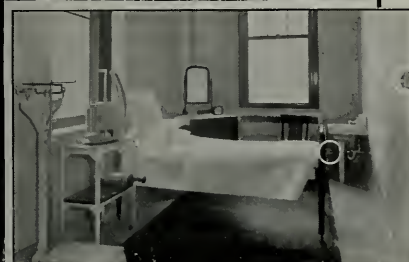

Basal Metabolism Room, St. Elizabeth's Hospital, Chicago, Ill. Showing Johnson room thermostat and radiator valve

GREATER SUCCESS IN CONTROLLING LIFE WITH CORRECTLY CONTROLLED ROOM TEMPERATURES

In hospitals, correct room temperatures are important. Operating rooms, oxygen chambers, premature birth incubators, private rooms and wards, preparation rooms, and the corridors through which patients pass, each present distinct problems as to the temperatures to be maintained. . . . A Johnson thermostat in each room controls the radiators in that room, separately and independently, solving the temperature problem for each individual requirement. There can be no oversight or negligence. Hospital personnel, relieved of this responsibility, is free to give undivided attention to technical work. . . . Ask to see a Johnson engineer.

JOHNSON SERVICE CO., MILWAUKEE, WIS.

Direct Branches in all Principal Cities



St. Mary's Hospital, Knoxville, Tenn. Crowe and Schulte, Architects. 125 Johnson room thermostats control 154 Johnson radiator valves

JOHNSON

AUTOMATIC TEMPERATURE AND HUMIDITY CONTROL

for Heating - Cooling - Ventilating & Air Conditioning Systems

OLD FASHIONED GARDENS

By BERNIECE ASHDOWN

IF there is a suitable corner in your yard for a simple design of informal planting, nothing could be lovelier than an old-fashioned garden.

It should include only the simplest of architectural features: neat bordered walks, a sundial or a grape arbor and somewhere a seat designed for comfort and rest. If there is an old tree handy, nothing could be more charming than a seat built around the trunk.

The planting should consist of the hardy, old, familiar flowers that pay such large dividends for the little care and attention they require. With rare exceptions they all do well in any good, fertile, well drained soil, if given a moderate amount of water.

In our modern rush for the new and different, we too often neglect the garden beauties of a few decades ago. Indeed, it is seldom that we see Sweet Williams (*Dianthus barbatus*) in the modern border, yet few flowers are so delightful or repay us so well for the little attention they require. The same may be said of their cousins, the clove pinks (*Dianthus plumarius*). Both thrive in almost any garden soil if given a sunny location.

Pungent Dutch hyacinths have taken the place of the dainty Roman hyacinth (*Hyacinth orientalis albus*). New double hollyhocks have replaced most of the more graceful single varieties; and the fragrant soft-petaled Damask roses have faded into obscurity.

My grandmother's garden held a multitude of these quaint and lovely treasures. There were brightly colored Verbenas and Geraniums and fluffy white Milfoil (*Achillea Ptarmica*), Evening scented stocks (*Mathiola bicornis*) and Damask roses: the soft white variety with the thorny stems and heavenly aroma and the large red ones that drooped on their stems. There were all sorts of fragrant herbs such as Thyme, Sweet marjoram, Sage, Mint, Lavender, Rosemary and gold flowered Tansy.

In early spring there were multitudes of Snowdrops and Crocus, followed by Bleeding Heart (*Dicentra spectabilis*), whose curious pink blossoms hung along arched stems above blue Roman Hyacinths and early Violas. Later, rich-toned Pansies and Polyanthus (*Primula polyantha*) with their gay colored blossoms arranged in ready-made boutonnieres edged the walk. Still

later, the treasured herbaceous Peonies burst into bloom one by one.

Pale Columbines (*Aquilegia*) four feet high bloomed in a sheltered semi-shady spot near the house. Early Mignonette (*Reseda*) exhaled their fragrance from a corner which they shared with small, yellow trailing Buttercup (*Ranunculus repens*) and pale For-get-me-nots (*Myosotis*).

Against a rugged stone wall there were graceful, single Hollyhocks (*Althaea rosea*) planted with blue, Ragged Cornflowers (*Centaurea Cyanus*), spicy little Nasturtiums, and the delicately scented Tuberoso-flowered Tobacco (*Nicotiana affinis*) that bloomed all summer with white trumpet shaped flowers.

Bold clumps of blue and yellow German

blocks of shade over the lawn. A long grape arbor led to the orchard and was flanked on both sides by groups of tall, prim Cosmos, Four-O'Clocks (*Mirabilis Jalapa*), charming single Canterbury bells (*Campanula Medium*) and Golden Glow (*Rudbeckia laciniata hortensis*) in its six-foot glory. Bright clumps of multi-colored Drummond Phlox (*Phlox Drummondii*) and Balsam (*Impatiens Balsamina*), passed in gay panorama with the seasons.

Perhaps the loveliest of all was a clump of pure white Madonna lilies (*Lilium candidum*) which burst into their glory late in May or early in June. Their fragile, wax-like petals and delicate fragrance gave them an indescribable ethereal quality and during their short blooming season, made them rulers over the domain.

The most remarkable thing about the garden was the simple ease and hardness with which everything seemed to grow. In spite of meticulous care, her garden never became stiff or suggestive of work. It was truly a place for repose where one could wander among ever-fragrant blossoms or lie in the old hammock which was hung between two large maples.

It was a garden alive by day with the hum of bees and chatter of nesting birds, and by night enchanted by the pungent fragrance of moist earth and blossoms, while an orchestra of crickets throbbed out their tunes.

Why don't you have one?

* * *

GARDEN NOTES

Rhododendrons and azaleas do best when kept mulched the year around with old leaves or pine needles.

* * *

Eucalypti have been known to grow fifty feet tall in five years.

* * *

Soil can be made acid by treating it with aluminum sulphate.

* * *

The merest trace of copper sulphate in the water of a pool will kill algae without harming the fish.

* * *

The color of *Hydrangea hortensis* blossoms is determined by the soil. An acid soil tends to give blue flowers while an alkaline soil will produce pink flowers with the same variety



The Bishop's Boxwood Garden, Mount St. Albans, Washington, D.C.

—Photo by Cecil Rawle Postlethwaite

Iris (*Iris vulgaris*) and taller white Siberian Iris (*Iris sibirica*) grew rampantly in the sun. Feathery annual Larkspur (*Delphinium ajacis*) showed their brilliant spikes of color in June; vivid, unruffled Petunias grew happily in odd corners and double Tuberoses (*Polianthea tuberosa*) deliciously fragrant and rich creamy white, bloomed in May.

In a favored corner grew a tuft of Zebra Grass (*Eulalia zebrina*). Often, to the great delight of us children, grandmother would pluck bits of green and ivory blades and tie them around our fingers or in our hair.

Cool, green Periwinkle (*Vinca*) covered one side of the dry wall terrace. Virginia Creeper (*Ampelopsis quinquefolia*) hung from the porch posts and in the autumn waved scarlet leaves, like gay flags.

There were great trees that splashed cool



● The long life of reinforced concrete construction is a proven fact! Add to this outstanding quality the other important features that favor Concrete Joist Construction. Speed of erection, without sacrifice of durability . . . big savings in labor

to towering skyscrapers—stand today as substantial tribute to these known facts about this truly modern construction method. To make every building you design a lasting contribution to sound architectural principles, use modern Concrete Joist Construction.

**CONCRETE
JOIST
CONSTRUCTION
means
PERMANENCE**

and materials . . . reduced "dead load", with its resultant economies. Concrete Joist Construction is the modern, economical construction method for any type of building.

Thousands of fine structures throughout America—from beautiful homes

● **SEND FOR THIS HANDBOOK**
A free copy of "Concrete Joist Construction" is yours for the asking. Send for this valuable 28-page Handbook today. It contains standard specifications, load tables and useful designing data.

CONCRETE REINFORCING STEEL INSTITUTE
Builders Building, (Department 58), Chicago, Illinois

- Forms Department Members:**
 Hugh J. Baker & Company . . . Indianapolis, Ind.
 Caco Steel Products Corporation . . . Omaha, Nebr.
 Colorado Builders' Supply Co. . . . Denver, Colo.
 Concrete Steel Company New York, N. Y.
 Donley Brothers Company Cleveland, Ohio
 Goldsmith Metal Lath Company . . Cincinnati, Ohio
 Hausman Steel Company Toledo, Ohio
 National Concrete Metal Forms Corp. Newark, N. J.
 Steelform Contracting Co. . . . San Francisco, Calif.
 Truscon Steel Company Youngstown, Ohio

Contributing Non-Members: Soule Steel Company, San Francisco; Mercer Steel Company, Portland, Ore.

CONCRETE JOIST CONSTRUCTION



PULSE OF THE READER POPULAR MAGAZINE

Dear Editor:

Will you kindly send me two copies of the May, 1938 issue of *The Architect and Engineer*, which issue contained an article by Mr. Vogel regarding my home.

You might be interested in knowing that for many years I have read your magazine, which may always be found at the Engineers' Club, and which seems to be one of the most popular magazines in the club library. Several features of my home were suggested by articles and advertising in *The Architect and Engineer*.

Thanking you, I am

Very truly yours,

ARTHUR LAUNDER.

Seattle, June 21, '38.

MODEL BUILDING PROJECTS

Dear Editor:

Perhaps the following brief description of a WPA project entitled "Models Depict Architecture of Ancient Buildings" will interest you and readers of *The Architect and Engineer*.

This Baltimore model building project is one of a number of such undertakings in various parts of the country. In Colorado, for instance, a model building project has produced material depicting pioneer days of the West, the development of the transcontinental railroad systems, the pony express, etc. In New York City, a project has been in operation for a number of months producing models of all kinds to be used in public schools as visual education aids.

Sincerely yours,

ROSCOE WRIGHT, Director

Washington, D. C., June 29, 1938.

Interested persons soon will not have to go to Europe, Asia, Africa and South America to inspect in detail some of the world's most famous architectural masterpieces. Nor will they have to wander the highways and byways of Eastern United States to inspect types of American colonial architecture. Provided, of course, that they be content to inspect miniatures built faithfully according to scale, since 12 of these are to be or have been constructed on a Works Progress Administration project at Baltimore, Maryland.

While tens of thousands of workmen, many of them in slavery, labored in some cases for generations to complete the original architectural masterpieces, each of its distinctive kind, the miniatures are the work of about 20 persons from the relief rolls under the direction of Benjamin Kurtz, well known Baltimore sculptor. And, while workers on only a few of the originals

are known to have been paid or to have received any reward for their work, the workers at Baltimore, in addition to having received a security wage, have become so proficient that most of them have excellent chances of future private employment, constructing models for fairs, etc.

Three models have been completed. They are of the Temple of Karnak at Thebes, the Ishtar Gate of Babylon, and the Throne Room of the Palace of Cnossus, Crete.

Two more were under construction in July. They were scale replicas of the Parthenon at Athens and the Arch of Titus at Rome. Remaining to be constructed are those of the Church of Santa Sofia at Constantinople, the Court of the Nunnery at Uxmal in Yucatan, the Cathedral of Chartres in France, the Temple of Ellor in India, and an Italian Renaissance palace. In addition models will be made of the Homewood mansion on the John Hopkins University campus at Baltimore, as an example of pure American colonial style, and of an ultra-modern American structure to be designed especially by Sculptor Kurtz for the purpose.

The reproductions will, for the most part, be about two feet high, ingeniously fashioned from wood and cardboard. They are or will be in most cases "sections" of buildings, some designed to show interiors and others exteriors. All are constructed so that they are shown as separate scenes on stages.

All the architectural details on the models are as historically accurate as research and the scale of the models permit, according to Mr. Kurtz. For instance small details on the hieroglyphics on the model of the Temple of Karnak necessarily had to be omitted, he said, but the hieroglyphics themselves otherwise are genuine reproductions.

In connection with the work on the models, the workers also have been completing costumed statuettes to represent the men and women of Ancient Egypt, Crete, China, Greece, Rome, Byzantium, Mediaeval Europe, Bagdad, Aztec Mexico, Elizabethan England, the France of Louis the XIV and Colonial America. The statuettes are about 15 inches high and will be displayed, along with the models, to pupils of the Baltimore schools before they become a part of a permanent exhibition.

COMPREHENSIVE REPORT

Dear Editor:

Thanks so much for *The Architect and Engineer* containing Mr. Michelsen's article "Unification of the Archi-

tectural Profession." It is a very comprehensive report of the work of our committee and the accomplishments of the New Orleans Convention. If possible, I would like to have you send copies of the magazine to Tom Cope, Arthur Holmes, and Leigh Hunt.

Very truly yours,

(Signed) JOHN R. FUGARD
Chairman.

Chicago, June 6, 1938.

PACK BOX ARCHITECTURE

Dear Editor:

When in Los Angeles some of the architects there were surprised to learn that "pack box" architecture was the exception rather than the rule in Mexico.

At the present time there are 37 substantial residences under construction here in Monterrey, all of which conform to traditional Spanish design of the villa type—the most pretentious of which are richly decorated in carved stone, wood and plaster with a generous use of decorated ceramic and ornamental iron work.

Further than this, a bullfighter remains the highest paid performer in the republic and there are still millions of Mexicans that think their country and its colonial architecture is the most beautiful on earth.

L. S. SANDERSON, Architect.

Laredo, Texas, June 26, '38.

Treat Wood with **CONSERVO**

The cost is small
the benefits 100 fold

Architects, structural engineers, builders, will find the penetrating power of **Conservo** a dependable preventative of **termite destruction**, dry rot and other forms of fungus and decay in heavy wood timber construction in factories, warehouses, bridges, wharves, etc.

Applied to old lumber, it penetrates cracks, holes, soft spots and checks further rotting or decay.

Write for descriptive pamphlet

GUNN, CARLE & CO.
20 Potrero Ave. UNDERHILL 5480
SAN FRANCISCO - CALIFORNIA



Picture

YOUR CLIENT...HAPPY...



.. IN AN ALL-GAS KITCHEN LIKE THIS

"It's perfect; you've thought of everything." Such expressions by clients spell SUCCESS —and one of your most effective aids is modern kitchen planning. It provides *efficiency* through step-saving arrangement and use of modern appliances, plus *sparkling beauty*, a constant source of pride. ☆ Pacific Coast Architects lead the nation in transforming the kitchen from a workshop into a social asset. And, increasingly, they specify GAS cooking, *water-heating*, *refrigeration* — plus gas-fired automatic *heating* to round out a complete home-comfort-and-economy plan. ☆ Your Gas Company gladly places its technical data at your disposal and invites consultation with its engineers.

CALIFORNIA ARCHITECTS who recently have designed "All-gas" homes include . . .
LOS ANGELES—Edgar Bissantz, Ralph C. Flewelling, Frank W. Green. ☆ ☆ SAN FRANCISCO —Mark Daniels, Albert Evers, W. P. Day. ☆ ☆ OAKLAND —Earl R. MacDonald, Miller & Warneke; and many others throughout the State.

MODERN TREND REFLECTED IN THIS HILLSIDE HOME



RESIDENCE FOR HENNA R. RODAKIEWICZ, LOS ANGELES
R. M. Schindler, Architect

THE ideals of space, adaptation to environment and utility are well illustrated in this modern residence by R. M. Schindler, architect, for Henna Rodakiewicz, Los Angeles. Located on a one-acre site at the foot of a small canyon, and with an outlook towards the ocean, this residence was planned to provide a simple style of living for a large family.

Both patio and playground were designed at natural and suitable positions, and the living room faces both the ocean and patio. The usual hallway connecting the bedroom was developed into a flower room with one wall facing the patio, formed of sheets of plate glass twelve feet high. The master bedroom is on top of the house and connects with the garden by means of a bridge across the patio.

In construction, the house is of wood frame with stucco finish and beach wood trim. Wainscoting in the kitchen is of bakemamel. In keeping with the modern design, gas fuel is used for heating, cooking and water heating. An automatic forced air gas furnace provides comfortable temperatures at all times, and an automatic gas water heater assures a plentiful supply of hot water.



Gas fuel is used for heating, cooking and hot water

“DATED” HOUSES

A house is old when it fails to provide convenience and comfort to those living in it. A house with a score or more useful years behind it may yet be young, and one built yesterday may not be modern.

The electrical age is here, and electrical convenience is increasingly important. Antiquated lighting or an insufficient number of convenience outlets definitely place a house in the “pre-electrical” age.

The house which provides for the convenient use of appliances will remain modern indefinitely. The house in which few outlets are available, requiring unsightly and dangerous extension cords run under rugs or festooned around the room is unnecessarily out of date.

Guard against premature obsolescence of the homes you design by including adequate electrical specifications.

RED SEAL plans, information, or consultation without charge or obligation.

PACIFIC COAST ELECTRICAL BUREAU

447 Sutter Street

601 W. 5th Street

SAN FRANCISCO • CALIFORNIA • LOS ANGELES

P. J. Walker Company

●

Builders

of the

Central Tower

San Francisco

ALBERT F. ROLLER

Architect

H. J. BRUNNIER

Structural Engineer

●

Other current work illustrated in this issue

OWENS-ILLINOIS PACIFIC COAST
COMPANY PLANT

Los Angeles

●

Sharon Building

San Francisco

FAITHFUL GUARDIANS OF ARCHITECTURAL BEAUTY



SPECIFY **DUTCH BOY** PAINTER PRODUCTS

Your client knows and your painting contractor knows you are specifying "quality." These paints have proved their ability to give outstanding service.

Your National Lead Company Specification Book gives you correct information for specific uses. . . . Or, if you need further technical service —

ASK THE NATIONAL LEAD MAN

National Lead Company branches in all leading cities

23 Stories of Paint!

ANOTHER GEM IN SAN FRANCISCO'S MATCHLESS SKYLINE, "CENTRAL TOWER," FORMERLY THE CLAUS SPRECKELS BUILDING, MARKET AND THIRD STREETS. ALL LACQUERING, PAINTING, DECORATING AND WATERPROOFING COMPLETED BY

D. ZELINSKY & SONS, INC.

"Leaders in the Painting Industry"

165 GROVE STREET • SAN FRANCISCO

Phone MArket 0721

★

ALBERT F. ROLLER, Architect
P. J. WALKER CO.
General Contractors

Los Angeles - Portland, Ore.
Seattle - Washington, D. C.

For Lasting Beauty

IN

Craftsmanship in Metal

OREGON BRASS WORKS ARCHITECTURAL METAL

*Universally Preferred by
Northwest Architects*



Plant of OREGON BRASS WORKS, Portland, Oregon,
Largest Architectural and Ornamental Metal Factory
in the Pacific Northwest.

Illustrated below is the Modern Bronze Entrance to the recently remodeled Failing Building Lobby. Lawrence Holford & Allyn, Architects.



OREGON BRASS WORKS

S. E. 10TH AND SALMON PORTLAND, ORE.

HOW MASTER KRAFTILE 6 x 9's "STRETCH" SMALL WALL SPACES



↖ VERTICALLY
HORIZONTALLY ↘

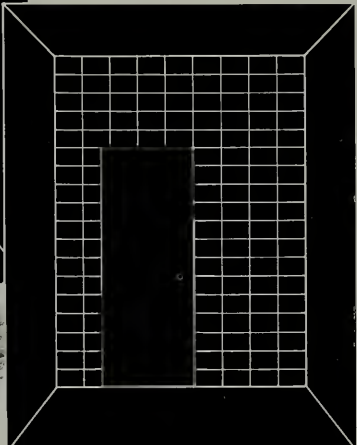

Set horizontally, walls gain a semblance of increased width; set vertically, height is added. Thus Master Kraftile's new 6 x 9's achieve with the eye a correction of proportion which the dimensions of the room may not otherwise permit. This is one of the many reasons this easily handled tile is becoming so popular in modern construction. Quicker to install, more highly fired than ordinary tile, available in a wide selection of attractive colors, *Master Kraftile now costs no more than regular 4 1/4" x 4 1/4" tile.* Write for free copy of illustrated folder. Kraftile Company, Niles, California. See your Sweet's: Catalog 5, Section 11

JOHNSON

Since 1904, the name of Johnson on an oil burner has been accepted as the seal of fine engineering, skilled craftsmanship and dependability. Johnson Burners on an architect's specifications insures satisfaction and comfort for the home owner. Johnson builds oil burners for every need of industry, commerce and home. Data sheets on each type of Johnson Improved Burners give complete information and specifications. Johnson engineers will be glad to assist in preparation of layouts & estimates.



THERE'S A JOHNSON OIL BURNER FOR EVERY PURPOSE
AIR-CONDITIONING? See the Johnson SELECTAIR, a compact, efficient unit which offers every desired feature for economical heating, air-conditioning and ventilating the home. With year-round domestic hot water. Oil-fired by the Johnson Pressure-type "Bankheat" Burner.
BOILER-BURNER UNIT? Test the "LADDI DU-ALL", a compact and completely automatic unit furnishing heat and hot water for small and medium-sized homes and apartments at low initial cost. ... *Descriptive bulletins on request.*

S. T. JOHNSON CO.

940 ARLINGTON, OAKLAND, CALIFORNIA
401 N. BROAD STREET, PHILADELPHIA, PA.

Why... HAVE AN ARCHITECT?

"THE worst punishment that God could inflict upon mankind would be to condemn us to live without architects," so wrote Blondel, an eighteenth century architect. Granted that he may have been slightly prejudiced, the fact remains that in the creations of man-made things,



brains are the most indispensable ingredient, and an architect's service assures quality, livability and high resale value.

When an architect specifies a DAY and NIGHT Water Heater for your home, he does so secure in the knowledge that there is no finer water heater made. He knows that the DAY and NIGHT HEAT TRAP—HEAT WAVE FLUE, and other exclusive features will save you many dollars every year of your Dayanite's long life. He knows of the twenty-eight years of gas engineering that has developed "America's finest water heater." He knows his reputation as an architect is strengthened when he specifies DAY and NIGHT.

Yes, architects are not only indispensable to home builders, but to the manufacturers of the finest household appliances.

DAY and NIGHT WATER HEATER COMPANY
MONROVIA, CALIFORNIA



Photo by Moulin

OLD TIMERS WILL HARDLY RECOGNIZE THIS AS THE LANDMARKED CLAUD SPRECKELS BUILDING, BETTER KNOWN AS THE "CALL" BUILDING, AT THIRD AND MARKET STREETS, SAN FRANCISCO. REID BROS. DESIGNED THE ORIGINAL STRUCTURE, ALBERT F. ROLLER WAS ARCHITECT OF THE NEW BUILDING.



Ornamental Bronze Grill, Sartorius Co., Inc.

DETAIL OF MARKET STREET FRONT, CENTRAL TOWER, FORMERLY THE CLAUD SPRECKELS BUILDING, SAN FRANCISCO

Albert F. Roller, Architect

CENTRAL TOWER – A NEW NOTE IN SAN FRANCISCO'S SKYLINE

SAN Francisco's Claus Spreckels Building, (better known as the Call Building) one of the first tall office structures to dominate the city's skyline, has recently shed its old garments for a more modern dress and simultaneously has taken a new name, appropriately termed the "Central Tower." This change of attire was prompted not alone by the change of fashions, but by the necessity of replacing much of the old sandstone above the fog "ceiling," coupled with the desire to make the building more efficient to serve present day demands.

After structural analysis, it was found that by using light weight concrete and definite limits of wall thickness, six floors of modern offices

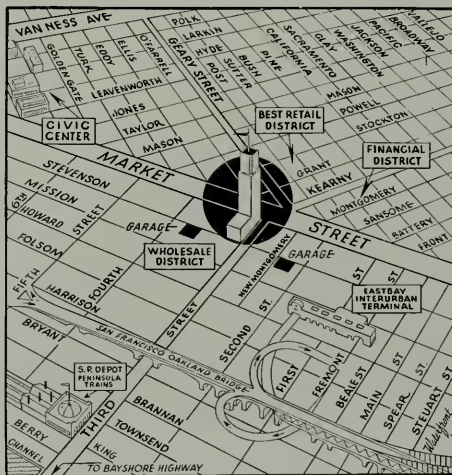

DIAGRAM SHOWS CLOSE PROXIMITY OF TOWER TO RETAIL, FINANCIAL AND WHOLESALE DISTRICTS OF SAN FRANCISCO.

LOSS OF PLANS OF ORIGINAL DESIGN MADE

could be made to replace the masonry dome and turrets with their exceptionally heavy floor



CLAUS SPRECKELS BUILDING AS IT LOOKED BEFORE MODERNIZATION. ORNAMENTAL DOME HAS BEEN REPLACED WITH SIX FLOORS OF RENTABLE OFFICE SPACE.

construction, together with the cupola, overhanging masonry cornice and belt courses and deep revealed arches. The old forms had served their purpose.

The exterior trappings below were stripped off and spandrels cut back, creating forms to give rise to the modern vertical treatment of the new tower floors. Contrasting materials formed a new base and entrance. Set backs of the new tower portion nicely balanced new loads on old structural centers. These structural centers were laid out in 1896 when contemporary thoughts were beyond the reach of the architect's imagination. The accommodation of new requirements of fenestration and story heights for the new floors to the scale and structure of the old, presented an extraordinary problem. The designers were further restrained by economic insistence upon simplicity of form and materials, the absence of embellishment and the preservation and adaptation of as much of the old structure as possible.

The builders also faced and met unusual problems, as the demolition of the old dome and erection of new frame were accomplished during winter storms. Temporary roofs and tarpaulins prevented damage to the lower twelve floors that were continuously occupied. Services to these floors were at all times maintained. The new elevators were installed one at a time, maintaining service in the other shafts. The old mechanism and surrounding columns high in the old dome had to remain while the rest of the structure was taken down and the new built up around them, and as it arose above them, one by one, the new machines took over the duties of the old. Thus part of the old structure came down as part of the new went up and those who observed the progress of construction saw a gradual transformation and emergence of the new form.

One floor at a time, the corridors and toilet rooms were modernized, and the entire plumbing system was replaced. Additional floor space and consequent greater revenue from the ground floor stores was gained by rearranging

RECONSTRUCTION WORK DIFFICULT FOR ENGINEERS

stairways and completely modernizing the lobby with bronze, marble and glass blocks.

To the south of the tower and separated from it by a 25'0" one story building, is a five story store and loft building, fronting on Third and Stevenson Streets and known as the "Annex." This has received a modern exterior treatment, a new entrance lobby from Third Street, new elevator and stairs. It has been connected with the tower by intercommunicating stairs and corridors in a new building of five stories that replaced the one story 25'0" building. This 25'0" structure has been designed as one with the modernized annex. These buildings now have direct access to Market Street, connecting on all upper floors with the tower and providing ideal lofts for clerical space, with adjoining executive offices in the tower.

Albert F. Roller was the architect, H. J. Brunnier, the structural engineer, Robert L. St. John, the electrical engineer and P. J. Walker Company, the builders.

STRUCTURAL PROBLEMS

by H. J. BRUNNIER, C. E.

THE structural engineering for the Central Tower Building was complicated by the fact that the plans of the original design had to be reconstructed by information from many sources. In fact, the story of linking this information together could, by a good imaginative mind, be written in a novel form. After unsuccessfully following through every possible lead of contractors' organizations connected with the original construction, endeavoring to obtain either design drawings or shop details, a research of engineering literature was started. Upon reading the reports of the effects of earthquake and fire on structures in San Francisco in 1906, there was found in the United States Geological Survey Report a reference to articles in the Engineering Record published during the month of April, 1898. These articles gave a fairly comprehensive description of the structural design and construction with some detail drawings and photographs. While insufficient, the information found here later devel-

oped to be of great value, as well as some discouragements.



A PLEASING TRANSFORMATION OF DOME TO A 6 STORY SET-BACK PAVILION WITH MODERN VERTICAL TREATMENT. P. J. WALKER COMPANY, BUILDERS.

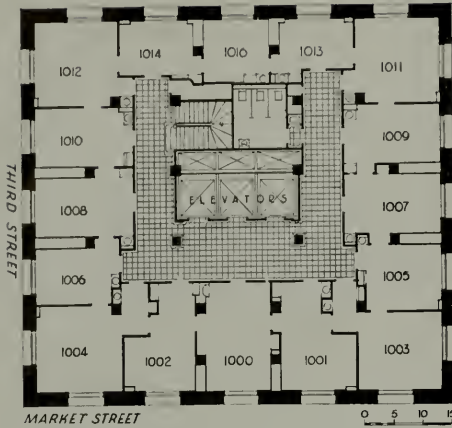

TYPICAL FLOOR PLAN
2nd to 13th inclusive

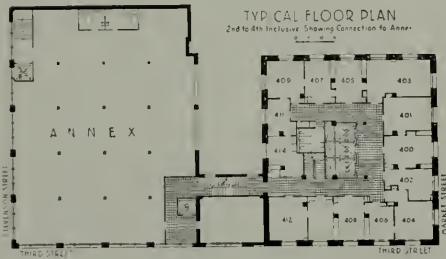

TYPICAL FLOOR PLAN
2nd to 13th Inclusive Showing Connection to Annex

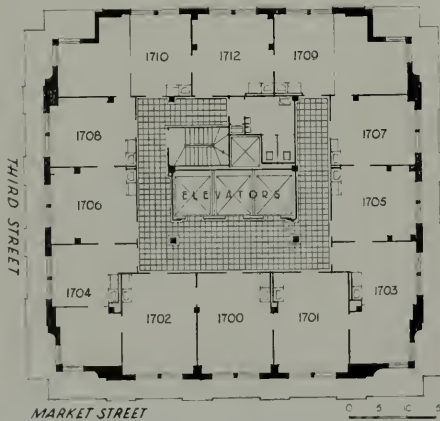

TYPICAL FLOOR PLAN
14th to 21st inclusive

These articles gave the information that Charles Louis Strobel of Chicago was the engineer and on checking up in the Year Book of the American Society of Civil Engineers, it was found that he was still a member. Upon writing him, we learned from his office that he passed away only a few months before and also that some time prior to his death there had been a fire in his office which had destroyed all his records.

Finally, an inquiry was made at the University of California and Stanford University but neither had a record of any plans of this building. However, Professor Derleth, Dean of Engineering, University of California, became interested and on investigating in an old storeroom finally located some blueprints which proved to be the floor plans and some sections of the steel framing. But the column schedule and the foundation framing were missing. The Engineering Record gave a complete description of the foundation. Therefore all the design information was available except the column schedule which eventually was reconstructed by exposing a sufficient number of columns on different floor levels to establish a ratio so that by interpolation the column sections for each tier were established.

The following is a brief description of the original building, based on data gathered from various sources: The building was 69'0" x 74'0" for 15 stories, terminating in a central dome about 60 feet in diameter with four more stories. The foundation is a very substantial construction, the base of which is 25 feet below the street level and consists of a concrete mat 2 feet thick covering an area of 96 feet x 100 feet and resting on a firm compact sand. On this platform 58 heavy steel beams are laid in one direction and continuous. On top of these and at right angles are placed 63 other full length heavy steel beams. The spaces in between the beams are filled solidly with concrete—thus making a solid mat foundation 4½ feet thick of an area approximately 70% greater than the area of the building. The building has a heavy structural steel frame throughout for the support of the walls and floors. Around the outside perimeter of the building there is a

heavy portal bracing system up to the fourth floor and from there up heavy gusset connections to all spandrel beams. In addition to this there is a system of diagonal bracing between interior columns, all of which are for the purpose of resisting lateral forces, such as earthquakes. The building was designed for a lateral force of 50 pounds a square foot.

A quotation from the Engineering Record of 1898 is of interest: "The development of the modern steel-cage construction of tall office buildings may be considered a distinctive mark of American architectural engineering, which is practically unknown abroad. A number of the most prominent of these structures which presented either special features or illustrated modifications of construction have been described and illustrated in these columns. These instances have been drawn mainly from New York, Chicago, Philadelphia and Boston, as the requirements which demand such lofty structures obtain chiefly in the largest cities. The direction of these buildings is not, however, confined to the cities named, and in the following columns we present a description and illustrations of a 19-story office building of advanced type recently completed in San Francisco, Cal. This structure gains in interest from having been planned for a region in which earthquakes are to be expected."

Likewise a quotation in part from the 1906 report of the United States Geological Survey is reassuring:

"Of all the commercial buildings in San Francisco, by far the most interesting was that known as the Call (Spreckels) Building, at the corner of Third and Market Streets. This building is remarkable for the care and skill shown in the design of its steel work. It is a steel-frame building, all the walls, floors, partitions, etc., being carried on steel work. . . . It is probably, on the whole, the best designed piece of such work in the United States. Another remarkable thing about it is that the execution was apparently as good as the design. . . . The bracing of the steel work seems to have taken up the vibration due to the earthquake, so as to preserve the masonry of the outer walls. . . . The engineer



ARCHITECT'S SKETCH OF MARKET STREET ENTRANCE, CENTRAL TOWER

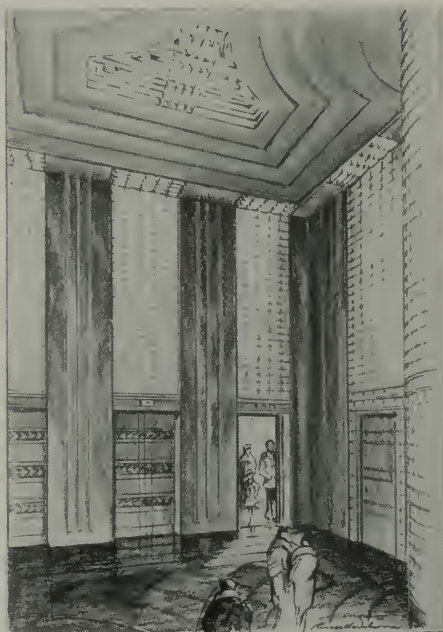

ARCHITECT'S SKETCH OF ELEVATOR LOBBY, CENTRAL TOWER



Photo by Maudin

Plastering by Marconi Plastering Com

ELEVATOR LOBBY, LOOKING OUT, CENTRAL TOWER, SAN FRANCISCO
ALBERT F. ROLLER, ARCHITECT



by Moulin

Terrazzo Floor by California Terrazzo Company

ELEVATOR LOBBY, LOOKING IN, CENTRAL TOWER, SAN FRANCISCO
ALBERT F. ROLLER, ARCHITECT

who designed the foundations and steel frame of this building may well be gratified at the admirable manner in which his structure fulfilled its purpose."

In the process of the alteration work, all of the masonry above the 14th floor was removed and it was found that no unusual care had been taken in the original anchoring of the stone masonry, although the large projecting stone cornice at the 15th floor was thoroughly bolted to a substantial steel framing bracketed out from the main steel frame. The removal of this masonry relieved the steel frame of a very considerable load and in particular the exterior columns.

All of the steel framing was removed to an elevation below the 15th floor, except certain columns, including the four supporting the machinery of the elevators. Incidentally, one of the problems that required considerable thought was to work out a method of demolition and erection of new work so as to maintain in operation at all times at least two of the three elevators.

Through the preliminary work, values of safe load carrying capacity were established for each column below the 15th floor and thus to obtain the most efficient maximum rentable areas in the added structure, a series of girders to support the new columns were framed into the existing columns at the 15th floor. The interior columns which supported the dome had

a far greater load carrying capacity than the exterior columns. The girders supporting the new columns of necessity framed between the exterior and the interior columns and the longitudinal location of the new columns approached a problem in the law of "diminishing returns." Since the exterior columns determined the limit of the loads that could be added and since it was essential that a balance be found between the rentable areas to be added and the cost of the work to be done, studies were made to determine whether to increase the total area by added floors of lesser area or increase the areas of each added floor and reduce the number of floors.

The final conclusion was the adding of six new rectangular floors with the exterior columns of the new construction set back 3'4" from the center line of the existing exterior columns. These old and new exterior columns were rigidly connected by X-bracing so as to tie into the lateral bracing system of the old building. The weight of the new work was reduced to a minimum by the use of light weight aggregate concrete for all walls and floors. Since the concrete for the exterior walls is the exposed finish there was careful supervision of the batching of the concrete so as to secure uniform workability and quality. The dry concrete has a weight of approximately 103 pounds per cubic foot and the 28-day tests averaged a compression strength of approximately 2700 pounds per square inch.



AIRPLANE VIEW OF MANUFACTURING PLANT, OWENS-ILLINOIS
PACIFIC COAST COMPANY, LOS ANGELES
Albert F. Roller, Architect



COMPLETED UNIT OF OWENS-ILLINOIS PACIFIC COAST COMPANY
PLANT, LOS ANGELES
Albert F. Roller, Architect

DIARY REVEALS INSIGHT INTO EARLY AMERICAN ARCHITECTURE

INTIMATE facts of early American history have been brought to light in many unexpected places during the last two years by workers employed in the Historical Records Survey of the Works Progress Administration. More than three thousand HRS employees are scanning old records—which have been discovered by them in many surprising places, in dusty attics, in dirty basements, jammed into staircase closets, etc.—in all parts of the country.

Locked in the yellowed pages of an old diary, recently discovered by researchers of the WPA in Louisiana, is a colorful chapter in the life of James A. Dakin, pioneer American architect. Dakin was the man who gave the famous James Gallier his first job in the United States at the salary of \$4 a day as his assistant. The subject of the Dakin diary discovery is a basis of an interesting report recently received at Washington HRS headquarters by Dr. Luther H. Evans, National Director of this WPA undertaking.

In the precise handwriting of the architect and builder, each stilted phrase formed in the flowery style of the middle 19th century, is recounted the building of the State Capitol in Baton Rouge in 1848.

Buried between an account of a shipment of lumber received by steamboat, is a notation recounting a fist fight on the scaffolding of the building with a member of a firm furnishing brick for the structure. The cause of the fight was the inferior quality of the brick furnished.

The faded handwriting reveals Dakin's disdain for the plans submitted by Gallier to the United States government for the erection of the United States Customhouse at New Orleans. He sets forth in the diary an account of the submission of his own plans which he considered far superior to Gallier's.

The document contains copies of letters from Isaac Johnson, Governor of the state, and A. D. Crossman, Mayor of New Orleans, to Robert J. Walker, Secretary of the Treasury of the United States, regarding a proposed visit to

Washington to discuss the plans for the Customhouse at New Orleans.

Dakin, the architect and builder of such edifices as the New Orleans Customhouse, the old Christ Church Cathedral and the finishing of St. Patrick's Cathedral, was far from the office architect of today.

Born August 24, 1806, he began his career in New York City. It was there young Gallier, fresh from universities in France, was given his first job in America. Dakin came to Louisiana and set up shop. He became a popular and respected citizen of his adopted state and was made a colonel in the Louisiana regiment which saw service during the Mexican war.

Charles Dakin, brother of James and also an architect, came to New Orleans in 1834 and formed a partnership with Gallier. He constructed St. Patrick's Church, the old Knights of Columbus Hall, the Merchants Exchange, and others buildings in New Orleans and died in the Crescent City in 1840, broken-hearted because the foundation of the Cathedral sank and threatened the entire structure. James Gallier strengthened the foundation and saved the church.

A stickler for honest construction, Dakin was continually fighting sub-contractors for materials according to specifications. Throughout the diary, he stresses the fact that \$100,000 was allotted for the old State Capitol building and he could not exceed that figure by one penny.

The Louisiana concern, McHatton-Pratt & Company, according to the diary, was given a contract to furnish the 3,000,000 bricks necessary for the construction of the building. The diary recounts the trouble Dakin was confronted with in getting good, hard, standard bricks and perhaps what was a most serious problem to Dakin is extremely amusing with the passage of almost 100 years.

The diary states:

"August 3d. In consequence of the very bad quality of bricks furnished by Messrs. McHat-

(Please turn to Page 49)

ALONG THE MISSISSIPPI

By HARRY M. MICHELSEN, A.I.A.

ONE afternoon in April we crossed the Huey P. Long Bridge, leaving behind picturesque New Orleans with its fascinating history and its quaint old buildings in the Vieux Carre. Flanked on both sides with levees densely populated with olive-green trees, the Mississippi extended like a muddy sea to the horizon, above which everchanging masses of white clouds, tinted with ivory, floated across a pale blue sky. To the south, the river followed a winding path through the cypress covered swamps into the Gulf. Rolling lands, spotted with natural evergreen trees, receded on either side of the river as far as the eye could reach.

As we travelled along the highway on our way to the historic gems of French, Spanish, and American Colonial architecture located along the west bank of the river, our interest was attracted by azure-blue water hyacinths which lay in silence on the dark green waters of the lakes, changing to a deep blue and then to a pale pearl color in the distance. Gigantic oaks, hickories, and sycamores, draped in trailing green-grey moss, lined the bayous, casting swaying shadows upon the motionless water; groups of cypresses seemingly conversed together in solemn dignity; tall grass gracefully swayed along the shores in the gentle spring breeze.

Plantation houses are located along the banks of the Mississippi and throughout the surrounding country known as the "Sugar Bowl." The early houses, a blend between Spanish and French architecture distinguished as the Creole type, are simple in design and plan, and well suited for the tropical climate of Louisiana. A few discriminating characteristics may be touched upon: the houses are one story, raised slightly above the ground on brick piers; cypress



HARRY M. MICHELSEN, PRESIDENT
STATE ASSOCIATION OF CALIFORNIA
ARCHITECTS

timber was used in the construction of the framework, voids having been filled with moss and clay or brick; and the gracefully pitched roofs are covered with split cypress shingles. All of the rooms have a common axis; porches with projecting roofs are found both in front and in back of the house.

Later the Louisiana type of house was developed, this being two stories high but otherwise similar in arrangement to the earlier houses. The lower floor rests on the ground and is paved with brick or stone; and the second floor balconies or galleries are carried on either square or cylindrical brick piers. Light, graceful, cypress columns, with open wood balustrades fitted between them, support the roofs. Stairways to the second floor are located

AUTHOR'S NOTE:—I wish to express my sincere appreciation to Miss Lutch Maria Riggs, A.I.A., who contributed certain important information that has made this article possible.



"OAK ALLEY," NEAR DONALDSONVILLE, LA.
Sketch by H. M. Michelsen, A.I.A.

at one end of the gallery. This style of house was built during the Spanish reign, and is often referred to as Louisiana-Spanish architecture.

When the American planters settled in the valley, the classic revival architecture found its way into the South, and was slightly modified to meet the tropical climate. Country houses built between 1830 and 1860 are surrounded with columns two stories high, with galleries on four sides, sometimes modified so that these features are only in front. These buildings were usually constructed under the supervision of French or British architects.

Many old houses now stand in great splendor, surrounded by oaks, hickories, and bays, fragrant magnolias and jasmine, red and white oleander, mimosa, and other tropical shrubs. Exquisite wax-like roses hang in profusion over the walls and balconies; Creole lilies and variegated flowers grow in abundance on these estates.

We first visited the "Homeland" plantation, a real old Creole house, having four rooms in a line, with porches on both sides. The mellowed cypress superstructure is supported on light orange colored brick with patches of stucco. A continuous gallery, with a stairway in the center, surrounds the upper floor. Interior details are distinguished by the excellently designed wood mantels of delicate workmanship that is symbolic of French architecture. Each room is designed with a fireplace which adds comfort to the living quarters.

The original kitchen was a separate building, which is now in ruins, and all that remains is the large brick fireplace, chimney, and a small part

of the roof, as a whole resembling a California outdoor barbecue place.

Continuing our journey, we admired the huge oaks standing like silent giants on the roadside, bending their ancient branches into graceful knotted forms, and covered with dark olive-green foliage. Fresh green fields were before us at all times, and soon we arrived at the "Whitney" plantation, which appeared to be unmolested through its many years of existence. This real old Louisiana plantation house has a similar plan to "Homeland," except that there is a cool, somber dining room on the ground floor. In front and back are galleries with stairs leading to the ground floor; all rooms open onto porches covered with climbing vines.

The living room ceiling has a light grey background, decorated in soft colors with medallions of blue and gold, all characteristic of the period of Louis XVI. Walls and mantels are true to French tradition, with all the refinement of the later Renaissance. Bedroom walls are well decorated, and the mantel, having well rounded mouldings and heavy pilasters, reflects the influence of Henry IV.

Farther on we came to "Oak Alley," which should be classified among the wonders of the



PRESCOTT HOUSE, NEAR BATON ROUGE, LA.
Sketch by H. M. Michelsen, A. I. A.

world. Enormous oaks, two centuries old and having a spread of about 160 feet, line the approach to the plantation house. There are now 28 of these trees, 14 on each side of the alley, forming an arch of interlacing beauty for about one-half mile. It is told that years ago these oaks extended twice as far, but were destroyed by the everchanging course of the river.

"Oak Alley" is one of the finest old plantation houses in Louisiana and was built by Governor Roman in 1836, replacing an earlier house which had occupied the site. The present building, surrounded with shell-pink Doric columns, and a gallery at the second floor, is a fine example of the classic revival period. A well proportioned roof slope forms a fine outline against the tracery of trees in the background. For many years it stood vacant before being purchased by Andrew Stewart, who, with the aid of Armstrong and Koch, New Orleans architects, restored it to its original magnificence. When viewed through the avenue of interlacing oaks, the house forms an interesting study of a beautiful architectural composition.

Entirely different from the "Whitney" and "Homeland," the plan includes a huge center entrance hall on the first floor which contains a stairway and provides access to the living and dining rooms. Bedrooms are on the second floor, and guest rooms, in the attic. There is no indication of an earlier kitchen out-building, which was probably destroyed during the "dark years."

The interiors of the rooms are well designed Georgian architecture, with walls and ceilings finished in soft oyster white. All of the furniture is antique and true to tradition of the period of architecture; the draperies, rugs, and furniture coverings are delicate pastel shades, of blue, peach, and rose, that blend together and suggest coolness and comfort.

Across the road from the entrance gates, the top of the levee affords a fine view of the river. Reflecting a burning red and orange sunset and broken clouds of fleecy gold, the muddy Mississippi was like a crimson lake, fading to aurora yellow at the horizon. Willows in the background formed a blue-green mass against the western sky, and to the east was the



UNCLE SAM PLANTATION, NEAR CONVENT, LA.
Sketch by H. M. Michelsen, A.I.A.

Bonnet-Carre Spillway to Lake Pontchartrain. Since twilight comes on rapidly in the South, these brilliant colors were almost momentarily transformed into the dusky tones of night.

Scented with the perfume from the jasmine and magnolia, a cool breeze accompanied the engulfing darkness, slightly stirring the silhouettes of moss-covered trees and reminding us that night had fallen. Reluctantly, we turned toward New Orleans, and in quiet reverie watched the flickering lights of the countless fireflies, reminiscent of the sparks from smoldering fires that burned during the early days of Louisiana.

NEW RACING PLANT HAS

Enclosed Paddock is World Innovation

WITH two of the largest and best designed racing plants in the country, Los Angeles has become a race track center second to none in the United States. Recently the initial summer meeting at the city's newest racing plant operated by the Hollywood Turf Club, was concluded with records made for attendance and financial speculation. The new plant is an impressive example of modern architectural design and is notable for a world innovation, an enclosed paddock, the first to be constructed anywhere.

Located on a 315-acre tract at Prairie Avenue and Century Boulevard, the track is on the east side of the grounds and the grand stand, which parallels Prairie Avenue, is set back from that thoroughfare to provide an immense area for parking automobiles. The stables are south of the track and east of the stand. The grounds between the parking space and the stand and inside the track are landscaped, a lake being the central feature. Large plumosa palms line the drive from Prairie Avenue up to the main entrance to the stand and are also conspicuous in the planting which is banked up against the structure.

The grand stand, facing east, is approximately 320 ft. long and 133 ft. deep with a large circular bay at the south end of the main section of the stand, in which the club facilities for the public and for the members of the Turf Club are provided. The stand has a structural steel frame erected upon a reinforced concrete substructure which rises to the main floor level. There are two decks, the upper one carrying about 13,500 seats, and the lower one forming a mezzanine. Access to these is provided by wide circular ramps on either side of the main entrance.

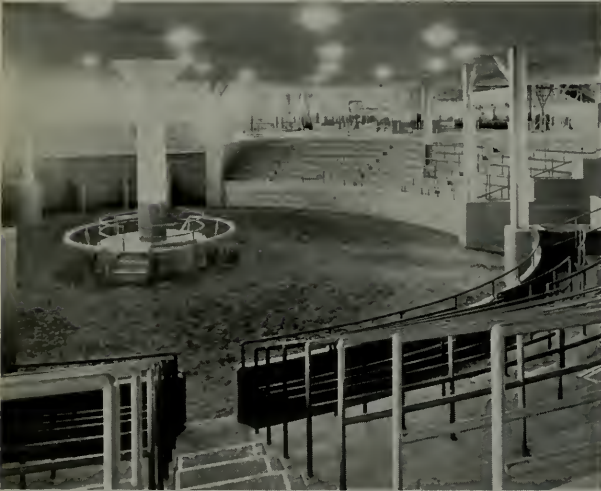

SOME NOVEL FEATURES

Floors of these decks are mill construction, consisting of 2x4's on edge, spiked together and covered with bituminous mastic. The enclosing walls of the stand are metal lath and plaster on wood studs, the exterior being treated with a light green waterproof paint. Horizontal lines are accented in the design by metal louvers extending the full length of the stand over the window areas.

The club rooms are on the top floor of the circular bay. These have polished oak floors and mahogany trim. The architectural treatment is modern—as is the furniture. One side of the circular club lobby is covered with high plate glass mirrors. On the opposite side, the walls are finished full height with mahogany veneer. The mutual windows, which are circular, are placed on this side of the lobby. On the floor just below the Turf Club quarters are the club rooms for patrons of the grand stand. The floor in the public club lobby is asphalt tile. Catering facilities for both floors are in an extension of the structure to the southeast.

The enclosed paddock on the ground floor of the circular bay is a novelty. The horses are brought from the stables through a separate building at the south end of the stand where they are prepared for the mounts and pass in under the stand to the paddock. This room has a diameter of 160 ft. with a ceiling about 20 ft. in height. The ring is 84 ft. in diameter with a platform in the center from which the officials may view the runners. On one side of the ring are stalls for 16 horses. A reinforced concrete stand for spectators is stepped up from the ring around the arena providing standing room for about 1000. On the side of the ring just above the stalls is a glass screen to prevent anything being dropped on the horses that might disconcert them. A runway from the paddock direct to the track is provided.

Stables have been built to accommodate 1600 horses. The plant represents an investment of \$2,500,000.

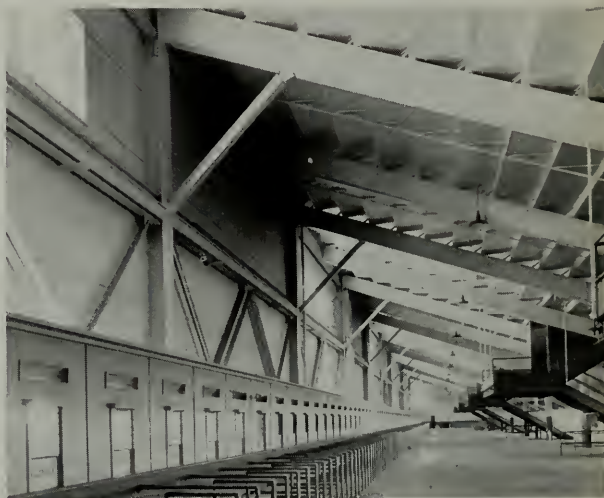

VIEWS OF NEW RACING PLANT OF HOLLYWOOD TURF CLUB, INGLEWOOD, LOS ANGELES
STILES O. CLEMENTS, ARCHITECT

Upper left on opposite page—Rear of Grand Stand, looking South.

Center—Enclosed Paddock, showing Ring and Spectators' Gallery. Officials' Platform in Center of Ring; Stalls at left.

Lower left—Rear of Grand Stand, looking North; Main Entrance in foreground.

Upper right, this page—View of Track from Grand Stand; note Stables in distance.

Below—Pari-mutuel Windows in main Betting Concourse.

Pictures courtesy, Southwest Builder and Contractor.



Photo by Moulin

Faced with Gladding, McBean Ceramic Veneer

**BUILDING FOR THE INSURANCE COMPANY OF NORTH AMERICA,
SAN FRANCISCO**

HARRY A. THOMSEN, JR., ARCHITECT



DETAIL, BUILDING FOR THE INSURANCE COMPANY OF NORTH AMERICA, SAN FRANCISCO
HARRY A. THOMSEN, JR., ARCHITECT

THE TREND OF MODERN TRANSPORTATION FACILITIES



SANTA FE PASSENGER TERMINAL
San Francisco

Designed by Engineering Department
Santa Fe Railway Co.

H. L. GILMAN, Architect

M. C. BLANCHARD, Chief Engineer

From its new centrally located Passenger Terminal in San Francisco, Santa Fe carries travelers by motor coach over the new Bay Bridge to connecting main line trains, and by transfer ways stages through to Eastern points. The new building is faced with Ceramic veneer, a machine-made terrazzo, manufactured by N. Clark & Sons. The colors are orange and blue.

TICKET OFFICE AND
WAITING ROOM, SANTA
FE TERMINAL DEPOT,
SAN FRANCISCO.



ARCHITECTURE—A PROFESSION

By EMILIO JOHN DI RIENZO, Columbia University

MUCH has been said and written concerning the profession of "Architecture." How much has actually been done by architects themselves to maintain the high standards of the profession and to protect them, is the proposition the writer would discuss in this article, and in addition thereto comment upon some practical solutions in the interests of the profession.

Speaking with architects, we find that they are dubious about the future; some apprehensive, some expectant, but none sure. One certainty is that whatever may happen to the architect or to architecture, both will continue to exist as long as civilization lasts. An architect is a master builder. Building will continue always and some group of men will be the master of it. They may or may not be the men we today call architects. If bankers, real estate developers, industrialists, or politicians determine how we are to build, they will be the real architects, even though they hire draftsmen and engineers to give shape to their ideas. The result will be good architecture or bad architecture, expressing truth or falsehood, frankness or hypocrisy. But we cannot avoid having architecture.

Architecture is the outward form of our civilization as it has been the lithic history of all civilizations. It affects and is affected by our political, social, and economic institutions. The ugliness and confusion of most parts of our cities, the slovenliness of many of our country villages, the shrieking falseness of many of our suburban developments, are the architectural expression of a defective society. The trained architects are there; our schools of today have finally awakened to the pulse of the times and are preparing architects as well as they ever did. But the profession itself has crawled into its snug little shell and has permitted the quacks to run riot over our field.

The architect has a duty to society over and above his duty to his associates, his clients, the

money lenders, etc. He will have no part in creating slums, in vulgarizing the countryside, in congesting the cities. His duty to society is to build more livable homes, more beautiful cities, more pleasant places of work. His duty is to build useful buildings in a beautiful way. His duty is to create beauty and discourage ugliness. If, by adding the individual parts, the architect cannot produce more than the sum of the parts, then he has failed. For the engineer can do that simple addition. The architect has to contribute that certain something which does not exist in the individual parts. His determined aspiration with his fellow architects is to produce a great architecture; one that will truly express the dominant aspirations of our civilization. When his work is done, he can say, "This may not be what we are, but it is what we hope to be."

TOO MANY QUACKS

But there is something wrong in the relationship between the profession and society. The greater portion of our buildings are not designed by architects, and many of them have the minimum architectural service to comply with existing laws. Thus many opportunities for creating beautiful cities go into the hands of the quacks who give us the well-known monstrosities

Now let us get to the core of the trouble. So far we have tried to briefly state the importance of the architect in the development of a society toward its highest ideals. We have also stated that the architect is there today, but for some reason he does not play his important part in the scheme of things. For some reason a great many of our important buildings are constructed without the benefit of his services, thousands of badly designed and uneconomic homes are forced on the community by the retired silk merchant just become "suburban de-

veloper." From every side the architect finds forces at work limiting his sphere of activity. He finds the field pregnant with devices intended to avoid the use of the architect. He discovers stock-plan experts, draftsmen working for small fees, manufacturers offering plan services with their products, the Federal Government chiseling down professional services to the detriment of the private architect, fly-by-night developers jerry-building thousands of structures by exploiting "talented younger university men."

Besides all these loopholes in the profession, the architect awakes with a stunned consciousness to the fact that the profession itself is not really doing anything about it. Occasionally one reads a fine article in one of the architectural monthlies. But the public does not see it. Occasionally one architect exchanges feelings with another. But still the public does not hear about it. In fact, the public is quite ignorant of the architectural profession, and public opinion is far from unanimous as to the value of the architect. To them the architect is still the fellow who makes blueprints for the contractors. He is thought of as a most impractical business man and a most unnecessary fellow. There is the rub.

Public relations play a vital part in the life of the other professions, corporations, and businesses. Millions are spent yearly to acquaint the Americans with the beneficent services of the telephone companies, the steel companies, and other industries. Professional associations, such as the American Medical Association and the American Dental Association, are constantly on the alert to see that the country is not misinformed concerning the function of the doctor or the dentist. Yet we sit by with an apparent indifference to the way our profession is presented to the public.

When one is ill, one immediately consults his physician, not the druggist. The medical profession has educated the public and the public's law-makers to the value of the doctor's services. The dental profession has likewise made the country aware of the invaluable and indispensable services of the dentist. Yet when a man contemplates a building operation, he usually

calls in the contractor, for some reason or other, and not the architect. The contractor then hires the architect or draftsman. The result: bad planning, uneconomic construction, ugly buildings, the owner has a white elephant, the community one more eyesore, and the architect has lost one more opportunity.

MISSIONARY WORK NEEDED

Without the concerted effort of each and every member of this honorable profession to show a willingness to stamp out the evil practices which are daily undermining our profession, we must make up our minds that we cannot and will not achieve the high aims and purposes to which we have dedicated our lives. It seems it is up to us to instill interest and enthusiasm into the individual local organizations and memberships and from these local media receive such publicity as can be had, so that in the final analysis the entire country may become aware of the position and importance of the architect in the community.

Our dilemma does not rest so much with the problem of honest competition between ourselves, but with the dishonest, fraudulent, and highly inexperienced competition from the unprofessional person who represents himself and appears to the public as capable of performing our work. Most of the complaint we can correct ourselves through honest publicity media. The rest can be cured by necessary protective legislation against the quack.

If we have been lax to protect our own interest up to the present, it is not yet too late, in the opinion of the writer, to put our shoulders to the wheel in our own self-preservation and in the interests of our noble profession. The position of leader in the community once held by the architect must be regained. He must win back his place as the originator, developer, and planner of fine buildings and cities.

Let us think not

"it nobler in the mind to suffer

The slings and arrows of outrageous
fortune"

BUT

"to take arms against a sea of troubles,
And by opposing end them."

"WHAT IS THE A. I. A. DOING FOR ME?"

By FRANCIS P. SULLIVAN

I HAVE had occasion recently to listen to some criticisms of the American Institute of Architects by its members; as chairman of one of its committees I have had letters reflecting such criticisms, and I am told by those best able to judge that this critical attitude is becoming more and more evident among the younger members of the profession.

The Institute, I have been told repeatedly, is asleep on its feet. It accomplishes nothing; it shirks the great issues in which its membership is interested. It ought to take a bold stand; it ought to tell the rest of the world where it gets off; it ought to make the United States Government do something about providing more jobs for Architects; it ought to step on the gas, turn on the steam, open wide the throttle, and go somewhere in a large way.

If it is true that the Institute's long record of accomplishments on behalf of the architectural profession—individually and collectively—and for the public at large are of no moment, then we may disregard all that the Institute has done with respect to Ethical Standards, Schedule of Proper Minimum Charges, Architectural Education, Public Information, Registration of Architects, Contract Document and Accounting Procedure, National Leadership and many other subjects.

If it is true that the Institute no longer serves the needs or advances the aims of its membership, there is no doubt that it is time to recast its activities along lines which will more clearly represent the aspirations of those who compose it. I believe it is very necessary, however, before undertaking such a reconstruction, to determine what these aims and aspirations are, because there are two possible alternatives: one, that the purposes of the Institute no longer measure up to the ideals and aims of its membership; and the other that the ideals and aims of the membership no longer measure up to the purposes of the Institute.

My reason for suggesting this second alternative is that a very large proportion of the criticisms that I have heard, when boiled down

to a brief phrase, amount substantially to the question "What has the Institute done for me?" or "What is the Institute going to do for me?". It was bluntly stated in the report of an Institute committee not long since that young men declined to join the Institute because they felt that it had not done enough to help them get commissions.

AIMS OF THE INSTITUTE

The aims of the Institute are set forth very clearly in the second paragraph of its By-laws:

To organize and unite in fellowship the architects of the United States of America; to combine their efforts so as to promote the aesthetic, scientific, and practical efficiency of the profession; to advance education in architecture and in the arts and sciences allied therewith, and to make the profession of ever increasing service to society.

I have studied this declaration of principle with great care and I am unable to see that anywhere in it is there the slightest indication of any intention on the part of the founders of the Institute to make the organization a direct means of putting money in the pockets of its members or of getting them jobs. It would seem rather that their purpose was, through the Institute, to give the architects of this country, as professional men, an opportunity to advance the interests of their clients, the public, and as artists to contribute to the development and perfection of the art which they practice, even though the advancement of their clients' interest and the development of the art should be at their own expense.

Put thus bluntly, this purpose may seem to many to be absurdly idealistic and impractical.

Nevertheless, if the purpose of the Institute is not precisely that which is stated, and if it does not intend to devote its efforts to that end, then this statement of principles is a piece of hypocrisy and the sooner it is erased from the Institute documents and replaced by a frank statement of what our aims really are, the better for the Institute and the better for the individual architect.

True enough it is an idealistic statement, but if there is any place where practical idealism

has its place it is in an organization composed of professional men and artists. I do not mean to suggest that an architect can disregard the fact that his profession is to him a means of livelihood. The point is that the existence of the architectural profession and the livelihood of the architect drawn from his practice of it depend entirely upon the fact that his clients believe that he will advance their interests even when they are in conflict with his own.

To indicate what I mean by this I would like to analyze the position of the architect first as a professional man and second as an artist.

As a professional man he is entrusted with the administration of the expenditure of his client's money. His only claim to have this trust reposed in him is the justified belief that he will administer this expenditure in the interests of the client even though these interests may be opposed to his.

To claim the title of an artist he must be prepared to pursue the highest aesthetic development of the buildings which he designs, even though in his research for this perfect expression he is obliged to devote a greater amount of time and money than if he had been satisfied with the first imperfect solution of the problem which presented itself to him.

In his private professional practice, therefore, he represents himself as willing to subordinate his own interests to those of his client and his work.

Just as long as his clients believe that these representations are true they will feel that it is in their interest to employ him. Whenever they believe that these representations are false and that the architect will look first to his own profit and secondly to the interest of his client, the whole excuse for the existence of the architect disappears. So that just in the measure that the architects adopt a commercially-minded attitude towards their work, they are cutting away the ground from under their own feet and destroying their own reason for being.

IS THE ARCHITECT SLIPPING?

This process, we must realize, has already gone far. There is no doubt whatever in my mind that the professional prestige of the architect is now declining in the public eye. I believe

that this loss of prestige is due in large measure to the very fact that the public believes that the advice of the architect can not always be accepted as disinterested and unselfish, but is some times open to suspicion as an attempt to benefit himself at the client's expense.

It seems very strange that, just at the time when the world at large is beginning to feel an increased sense of social responsibility and to realize that the pursuit of the dollar is not man's most important purpose, we should find among some in our own body a tendency to revert to an out-moded philosophy of life.

It is curious also to observe how frequently this particular point of view is attributed to the younger men of the profession as if they, as a group, stood for a course of action mainly shaped in their own self-interest. It is among these men, if anywhere, that true idealism ought to be found; among men whose enthusiasms are still fresh and vivid, whose consciences are not yet dulled by contact with the cynicism of the market-place, whose responsibilities are not yet so staggering that they outweigh the claims of justice, honesty, and truth.

These are the men upon whom I believe we can depend to foster the most noble and generous view of their professional duties and responsibilities.

I believe that it is our duty when these men ask the Institute what it has done for them or what it will do for them, to tell them frankly, "You are missing the whole point of the Institute's purpose." The real question is, "What can You and what will You do for the public good and for the good of your profession?"

It may be that conditions demand that there should be an organization which should be mainly concerned with the advancement of the material benefit of the architect. Even so there still remains room for an organization whose principal efforts are concerned with those objects laid down in the Institute's present statement of principles. What we must clearly understand is that we can not carry water on both shoulders; that the two purposes are in a measure contradictory and that no possible organization can be framed which will accomplish both of them satisfactorily.

BACKGROUND OF CRITICISMS

It is of course possible, and indeed probable, that I have misunderstood the meaning of these criticisms and have read into them something which they were not intended to express. If this is so the very fact that I have misunderstood them indicates the need for them to be stated more clearly.

If the members responsible for them mean merely that they believe that the Institute should pursue the aims which it sets forth in its statement of principles with greater vigor and more earnest effort, and if it be true that we have in any way slackened in our pursuit of these objects let us, by all means, buckle down to the task with renewed earnestness.

If they mean, however, that the membership desire to direct its actions toward a different goal from that laid down for it in the past; if they desire that the Institute should devote its efforts to pushing the pecuniary benefit of the architect, to getting him more and better jobs, to making him commercially successful, let us know it and admit it and state it in plain words so that we and the public may know where we stand.

For the most important thing in life is for us to understand clearly what our own purposes are. A man who understands what destination he desires to reach, has some hope of getting there eventually even though he may reach it by a circuitous route, but the man who feels vaguely that he would like to go to Canada, and that on the other hand there would be some advantage in going to Panama, will in all probability never reach either place but will run out of gas somewhere in the neighborhood of Lincoln, Nebraska.

And the next most important thing is that we should adopt the means that are best adapted to accomplish the purposes defined. The man who has devoted his efforts to constructing an instrument of precision for scientific uses cannot reasonably complain if it is not efficient in breaking rocks. If we have deliberately built an organization which is intended to accomplish altruistic ends, to advance the public good, and to promote professional efficiency it is absurd to criticize it on the grounds that it does not at the same time directly promote our material interests and help us make more money.



BUILDING FOR DEAN WITTER & COMPANY, WESTWOOD, CALIFORNIA
Allan G. Siple, Architect



Seating by American Seating Company.

AUDITORIUM, FIRST CHURCH OF CHRIST, SCIENTIST, BEVERLY HILLS
P. P. Lewis, Architect

Note the fluted pilasters at each side of the rostrum and the extensive use of both run and ornamental cast cement. The ceiling and walls are treated with acoustical plaster in color.

FIRST CHURCH OF CHRIST, SCIENTIST
BEVERLY HILLS, CALIFORNIA

P. LEWIS, ARCHITECT
SCHERICH BROS., BUILDERS

Construction is of reinforced concrete. Exterior
plastered. The main auditorium is pictured be-
low. At the left of the main entrance, ap-
proached by wide steps, is the Sunday School
unit, covering approximately the same floor
area as the church. The cornices and Sunday
school entrance, shown at the right, are of cast
concrete.

Illustrations courtesy California Plasterer



ENTRANCE DETAIL, SUNDAY SCHOOL UNIT,
FIRST CHURCH OF CHRIST, SCIENTIST,
BEVERLY HILLS, CALIFORNIA



Structural Steel, Pacific Iron & Steel Co.

FIRST CHURCH OF CHRIST, SCIENTIST, BEVERLY HILLS, CALIFORNIA
P. P. Lewis, Architect



AUDITORIUM AND FIRE HOUSE SANTA CRUZ CALIFORNIA
MARK DANIELS A. I. A. ARCHITECT SAN FRANCISCO

CIVIC AUDITORIUM, SANTA CRUZ, CALIFORNIA
MARK DANIELS, A. I. A., ARCHITECT

The auditorium proper has a seating capacity of 2200 with a permanent bank of seats on three sides of a basket ball court on the main floor. The plans also include seven conference rooms, diet kitchen, dressing rooms for actors and athletic teams. A feature of the building is a tower from which will be broadcast Christmas and Easter carols and other music, from a great organ.

BETTER and SAFER HOME OWNERSHIP

By JOHN H. FAHEY

THE thrift and savings institutions of the United States for decades have rendered an extraordinary service in the development of this country. Your mutual savings banks, the building and loan associations and the life insurance companies, as well as the savings departments of the commercial banks, have safeguarded the small hard-earned savings of millions of our people and have been almost entirely responsible for providing the funds with which our urban homes have been built.

Great as their public service has been in the past, it seems to me that the mutual savings banks and all classes of savings and lending institutions are today confronted with far greater responsibilities and opportunities for usefulness than ever before. Their operations represent not only services of fundamental value to savers and to borrowers but to the country as a whole. Saving, borrowing, building, all have a close relationship to national prosperity, to our steady progress, and to the maintenance of economic stability.

It is generally recognized that in the field of production nothing is more important to the national welfare than steady but safe activity in the construction industry. No one can analyze the facts and figures carefully without realizing that we have in this country today a very great housing shortage. It is undoubtedly the largest we have ever had. As has always been the case, conditions relative to the need of housing vary from one section of the country to the other, but it is here and it should be met without delay. The sooner we deal with it intelligently and energetically the better it will be for all of us. Aside from the definite shortage of housing which we know exists, it is also apparent that there are hundreds of thousands of disgraceful shacks in existence in this country which are still called "homes" but which really are unfit for human habitation and should be destroyed. The housing problem of the United States is one of our greatest problems. It is a complicated

problem and we will not find satisfactory solutions all at once.

ENGLAND FAR ADVANCED

Nevertheless, that should not deter us from employing all our efforts and ingenuity, and utilizing the enormous resources at our command, to get at it without loss of time. Great Britain, which undoubtedly has led in providing better housing for its people, has been experimenting for half a century. It has not answered some of the questions which arise in connection with any study of housing, but during the last seven years particularly it has certainly gained more from experience and accomplished more in the housing field than any other country in the World. With our resources in men, material and money, unrivaled in any other country, the United States should be able to provide for its people not only the best but the most economical housing to be found anywhere.

The kind and quality of housing which the country needs cannot be provided, of course, except through the energetic employment of private enterprise and private funds—primarily as in the past through mobilization of the small savings of the great mass of our people—but the task will not be accomplished in my judgment through the activity of private enterprise alone. Complete cooperation of private enterprise and the Government agencies active in the housing field is as important to success and safety as the intelligent management of those who direct private organization. Real achievement means that mortgage lenders, labor, land owners, architects, builders, material suppliers and all others interested in construction must really work together and not just talk about it.

When we enlist with enthusiasm in that spirit as did the people of Britain, the results will come. In undertaking such a comprehensive program we should recognize the part which Government can and should properly play. I think it is important for business men to realize that in conjunction with them there are some things which the Government can do in the

interests of all, which they cannot do for themselves.

REAL ESTATE SPECULATION

In the field of housing and mortgage lending the depression experiences since 1930 surely demonstrate this fact. Although I do not think the evil has ever received the attention it deserves, over-speculation in real estate is as dangerous to the general welfare as over-speculation in securities. Extreme speculation in real estate contributed as much toward the collapse which followed the 1929 panic as any other weakness in the economic structure. Just as private enterprise had no facilities for common action to restrain the dangerous real estate speculation which went on in many directions before 1929, so also it had no effective means for dealing with the chaotic conditions which developed in the mortgage field immediately thereafter. The Government—and only the Government—had sufficient power, resources and public confidence to check the steady decline in home values and constantly increasing foreclosures which menaced the nation's homes.

If we are to deal adequately with the problem of protecting savings, provide mortgage money on a sound basis, and give the country the housing it needs and should have, it is worth while to consider briefly the events of recent years in their relation to thrift and home ownership.

Let us recall that in 1932 there was held in Washington a great national conference on the subject of housing. A long list of committees labored for many months before that meeting. The best authorities in the land worked hard to contribute toward the formulation of a national housing program. There were many differences of opinion, of course, and it is well to remember that unfavorable economic conditions, the full significance of which were not given sufficient consideration at that time, prevented the attainment of results from that conference which might have accrued otherwise. The truth is that the conference came too late—at least ten years too late. Out of it, however, there was one very important recommen-

dation which received the approval of the President and, soon after, of Congress. It provided for the organization of the Federal Home Loan Bank System. This was to be a financial institution the membership of which would be mutual savings banks, building and loan associations, cooperative banks, and life insurance companies. It was to operate along lines similar to those of the Federal Reserve System and to render to these savings and mortgage lending institutions services similar to those rendered by the Federal Reserve System to commercial banks.

RESERVE FOR HOME FINANCING

The purpose was to afford these mortgage lending institutions a resource to which they could turn at any time when they might need money, without being forced to sell at a loss valuable investments or to foreclose or sell home mortgages which should not thus be sacrificed. This mortgage reserve system of twelve regional banks was also conceived of as a facility which in conjunction with the Federal Reserve System and the Federal Land Banks, representing the farm mortgage interests of the country, should represent a power able to meet any financial emergency, to forestall panics and prevent the terrific losses with which we have been afflicted in the past because of the lack of adequate reserve institutions to deal promptly with such difficulties.

As you know, unfortunately the Federal Home Loan Bank System, with 125 millions of capital provided by the Government, came into existence too late. It was not ready to function until the Fall of 1932 and it was unable to stem the rising tide of foreclosures which was sweeping the country.

As a result, to meet the acute home mortgage distress, the Government was forced to enter the field of direct lending in the summer of 1933 and Congress established the Home Owners' Loan Corporation. If, long before that, the private mortgage lending institutions of the country had pooled their resources, forgotten their jealousies and the irritating incidents which always grow out of active competition, they could have prevented development of the

mortgage panic to the proportions it assumed.

If these institutions had seen the advantage of mobilizing their great power through the medium of a comprehensive reserve bank system twenty years ago, in my judgment most of the weaknesses in our mortgage lending system, which have become so apparent since 1930, would have been cured, and the impact of dangerous financial developments would have been met with much greater success long before 1933.

The organization of the Home Owners' Loan Corporation and the advent of the Government into the field of direct lending not only rescued the homes of some millions of families from foreclosure, but it also saved thousands of lending institutions from collapse. In that process, it is well to remember that its operations prevented the loss of savings in these institutions to a great host of people and it soon placed in circulation at a time when it was badly needed, two billions of dollars, including over half a billion tied up in closed banks.

The Home Owners' Loan Corporation is an emergency agency of the Government. Temporarily it served as a great mortgage reserve institution. It was created to meet an unusual condition, but the lessons we can learn from its operation should not be forgotten. They can be extremely helpful to all savers, to all mortgage lenders, and to the country. Before it stopped lending in the summer of 1936 it closed a million and twenty one thousand loans amounting to three billion one hundred millions of dollars. These loans were made in every county in the United States, in Alaska, the Hawaiian Islands, and Puerto Rico. They are to be found in practically every town of 2500 inhabitants, as well as in our more populous centers.

UNSOOUND MORTGAGE OPERATION

In the development of the Home Owners' Loan Corporation we found that various weaknesses had contributed to the unsound situation in the urban home mortgage field which precipitated the mortgage panic. Over-lending, stimulated by excessive appraisals, and the existence of the inflated second mortgage, were the chief defects the Corporation encountered

in undertaking to refinance home mortgages in process of foreclosure. Most of the second mortgages involved bonuses of 25% or more and few of them carried interest rates of less than 9%. Some were as high as 16% and 18%.

Excessive interest rates, in various sections of the country, represented a threat to the home owner and, as I think is now generally recognized, the existence of so many short term mortgages for a modest part of the supposed value of the property, was not only a menace to the borrower but it proved dangerous to the institution. Most of the evils in our mortgage system to which I have referred are disappearing, and out of the experience we are going to have, in my belief, a better and a sounder mortgage structure—better for the borrower because it will be fairer and safer for him, and better for the savers because their savings invested in mortgages will have greater protection.

I presume that there will always be a certain proportion of home mortgages made for three or five years and representing but 50 or 60 per cent of the true value of the property. Because of the depression experiences of borrowers and also the institutions, however, it seems to me inevitable that most lending institutions hereafter will make longer term amortized mortgages. I believe they will insist upon better appraisals than have prevailed in the past and recognize that modest, regular payments on a mortgage over a series of years is of great importance to the lending institution as well as a real advantage to the borrower.

ADVANTAGES OF LONG TERM LOAN

Such success as the Home Owners' Loan Corporation has achieved is due largely to the liberal character of the loan offered by the Government and the fact that it was to be paid in monthly installments spread out for fifteen years. On the average these million loans, when refinanced, were over two years in default on principal and interest and between two and three years on taxes. The homes thus mortgaged were lost to their owners. When these obligations were reduced, however, to moder-

ate monthly payments, borrowers, with confidence restored, were able to meet the charges. When one recalls the hopeless character of these loans taken over by Home Owners' Loan Corporation, it is interesting to observe that as of the first of any month the Corporation has had paid in approximately 85% of all the accruals due on the loans now outstanding. You will agree I think that this is but a renewed demonstration of the integrity and respect for obligations of the American people.

It is true that the Corporation has completed foreclosures on some 70,000 homes. It will be obliged to take over others as additional foreclosures proceed. A large portion of the foreclosures are due to death, abandonment and willful default. The Corporation does not foreclose, if there is any reasonable alternative. On the average in the country our foreclosures represent over twenty months of failure to meet payments and over two years of tax defaults. The outstanding fact is not that the Corporation may ultimately have fifteen per cent of foreclosures but that 85% or more of homes that were absolutely lost have been saved. The explanation, as I have said, is that if you give honest people who are living within their means a fair chance to pay, they will pay. When we think of long term amortized loans for a substantial proportion of the value of a home it is worth while remembering that HOLC loans were high percentage loans and to borrowers in distress. I have seen 40% loans which were grave risks and 100% loans which were sound. The real test of any mortgage loan is not merely the property security but the man behind the loan, and whether he has a fair chance to pay it within the stipulated time.

SHOULD DISCOURAGE "OVERHOUSING"

In making loans on urban homes, I think it is important that mortgage lending institutions should not overburden the borrower by encouraging him to assume an obligation on a home he cannot really afford. Too much of the trouble with which the Home Owners' Loan Corporation had to deal was due to the attempt of borrowers to live in homes which by no stretch of the imagination they could ever hope to pay for. The fault was not theirs alone, for lending

institutions too frequently, under the pressure of real estate promoters, were unwise enough to acquiesce in the making of excessive loans. The lending institution renders a real service not only to the borrower but to the community when it helps the borrower to see that he should not take on an obligation he has no chance of discharging. Moreover, the lending institutions which adhere firmly to such a policy justify the confidence of their savers as well as the public.

At the same time, let me say that I believe that enterprising mortgage lending institutions today should energetically go out after business in the interest of their savers as well as to help in solving the housing problem. They should seek good loans, and in doing so, educate the borrower as well as the public on good housing and sound lending. May I suggest that the day has passed when the mortgage lending institution can sit by and wait for borrowers to seek out its services. I think it must sell itself to the public more energetically than ever. It should not only stress the safeguards it provides for those who entrust their savings to its care, but it should arouse the interest of those families in the community who ought to have homes, or better homes, and who can afford them safely. These prospective borrowers they should help, in my judgment, in planning the worthwhile home and in seeing that it is soundly constructed. As a result its loan will not only be better protected but the borrower will be given the benefit of experience he cannot otherwise command.

By all this I mean that, as in almost every other direction, today there is need for studying and giving full consideration to new ideas in home building and mortgage lending without in the least abandoning those principles which have proven sound in the past. While we are thinking of building new homes and making new loans, let us not forget to provide the utmost possible protection to the millions of workers in this country whose small savings accumulated in our institutions represent that great reservoir of funds with which most of our homes are built. Savings are rising again. They will continue to increase especially if we see to it that the man in the street has every reason to believe his savings are safe.

CONSTRUCTION OF MOUNTAIN HIGHWAYS

By ERNEST McGAFFEY

ROAD building in a number of the states presents a comparatively simple proposition. The soil in such states is everywhere about the same, and there are no mountain summits to be grappled with. The rivers are not subjected to sudden and disastrous floods, and the rainfall is so evenly distributed that it offers no major difficulties. Bridges can be economically constructed, with rarely any danger of their being swept away. As to highway maintenance, the extremes of winter and summer very lightly affect the surfacing, although at times deep snows may require considerable expense to keep the roadways clear. But where, as in California, the country is liberally supplied with mountain ranges and lofty peaks, the problem of highway building becomes a vastly harder nut to crack.

Where the necessity for putting in mountain highways exists, conditions may vary in different areas of the same state. In certain sections, considerable timber has to be chopped or sawed down, yet there may be only a comparatively small amount of heavy rock work encountered. In other states, or other places in the same state, the main task consists in surmounting the grades, without much big timber to contend with, and only occasional rock work to handle. In still other conditions embracing the mountain country, highway construction includes the felling of numbers of scattered trees, the preparing at some points of a solid sub-grade, more or less culvert and bridge preparation, and sometimes long stretches where sheer walls of granite, sandstone or limestone obstructs the line of route; and where drilling, blasting, crow-baring and pickaxing are the only means of forcing a passage through such almost un conquerable barriers.

The advances in mountain highway building during the past twenty-five years have been nothing short of phenomenal. The improve-

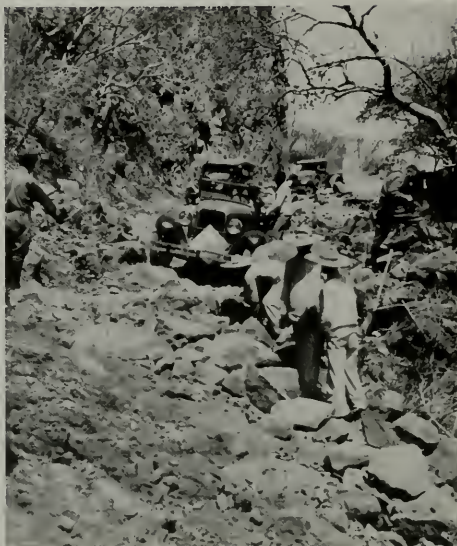

WHERE MODERN ENGINEERING BUILT A MOTOR HIGHWAY IN MEXICAN MOUNTAIN GORGES. FIRST SCOUTING TRIP OVER THE BARRANCAS COUNTRY. THREE TENTHS OF A MILE AT THIS POINT TOOK A DAY FOR THE AUTOMOBILES TO TRAVEL. ALMOST A FOOT AT A TIME.

ments in highway machinery have kept step with these advances, and the engineering profession has reduced the art of constructing these mountain causeways to a uniformity which has attained to a nearly perfect degree of efficiency. Of course there can be no absolute prevention of sporadic rock slides, earth slides, and cloud-bursts in a mountain country, because these unforeseen catastrophes naturally entail an inevitable risk. On some of the higher elevations the roadways are so narrow that "controls" have been established, where automobiles are only permitted to drive one way at a time, as there is no possibility, in places, of room for cars to pass one another.

The engineering force which moves forward along the line of a mountain highway is as carefully provisioned, thoroughly equipped, and ably commanded as an army in the field.

It is, in fact, an industrial army, and it would be a long stride ahead in our so-called civilization, if such armies were the only ones in the strenuous progress of the world.

The machinery composing the heavy and the light artillery of this army, ranges from ponderous power shovels and huge trucks, to the one-man compressed air and hand-worked drill, which has replaced the old drill and hammer process with a marvellously effective factor in constructive value.

The spanning of mountain streams by the erection of steel and concrete bridges is a work of particular importance in connection with the installation of the mountain roadways. Many of these structures are liable, especially in the spring months, to be pounded savagely by seasonal floods or infrequent cloud-bursts; and must be able to successfully withstand not only ordinary, but even extraordinary emergencies. Travelers from the Prairie States, or states where there are no mountain summits, are often amazed at the elaborate and sturdy buttressed structures in the way of bridges over the mountain gulches, which they find in the far Western States, and along the coast of the Pacific Ocean. Perhaps at the time they cross these gorges there may be a peaceful little current meandering under them which looks entirely harmless. But in April and May, when the drifts on the mountain ranges are melting, these apparently placid brooklets may be quickly changed to raging torrents, not only gnawing at foundations and approaches, but bearing on their surfaces boulders and trunks of trees which batter at the length and breadth of the bridges with the fury of an avalanche, and test their strength and endurance to the utmost limit.

Drainage by means of culverts is an essential element in the work. For ages the arch has been recognized, with its central bulwark, as the very embodiment of lasting permanency. No one knows this as fully as the highway engineer, whose work leads him through the mountainous regions. Wherever there are indications that an unusual flow of water may be expected at times, stone culverts are often put in to meet such emergencies. As such

adjuncts are expected to last as long as the highway itself, their construction is carried on with mathematical precision and the highest maximum of thoroughness and skill.

At other places on a mountain highway where only a small volume of water can reasonably be apprehended, round metal culverts are usually laid down. These are capable of sustaining great weight, and immunity from rust, and are of approved standard makes, tried and tested for their efficiency; and will last almost indefinitely. Special preparation for melting snows bringing floods from the mountain heights is one of the vital needs in preventing damage to mountain highways, and no pains are spared to accomplish such a desirable purpose. No road through the mountains is stronger than its weakest link, and proper drainage is a super-important factor in its final completion.

If a bridge is washed out on a highway that leads over level ground, or where a portion of such a roadway is carried away by reason of a wrecked culvert, a detour can often promptly obviate the difficulty for a while. But very often the destruction of a bridge, or the clogging of travel across a bridge by having trees cast upon it, may mean a complete stopping of cars at that point until the bridge is replaced, if carried down stream, or the debris is removed if the bridge still remains. The building of a mountain highway requires an unusually strict supervision in each and every one of its branches, and the engineering responsibility is a weighty one.

Present day engineers can and do build travelable motor highways, over cliffs where before they started in, a mountain sheep or billy-goat would have broken his neck trying to climb. Mexico has just finished a passage-way which was once the untravelled section of the Barrancas region between Plan de Barrancas and Magdalena in the Republic of Sonora, Lower California, Mexico. This section is a part of the projected International Pacific Highway from Fairbanks, Alaska, to Buenos Aires in the Argentine Republic, South America. It includes 29 miles, and the first scouting trip over it took



FEATHER RIVER CANYON BRIDGE ABOVE WESTERN PACIFIC RAILWAY,
NORTHERN CALIFORNIA

16 hours and 45 minutes to cross. The journey was headed by the Chief Engineer of the Automobile Club of Southern California and at one point a whole day was taken to cover three tenths of a mile. No wheeled vehicle had before attempted the feat. Yet today the Barancas can be crossed with motor vehicles because of modern highway science and latter-day engineering.

The stimulus to touring, by reason of the construction of these cloud-approaching automobile highways, cannot be rightfully overestimated. They bring the motorist to unsurpassed and unsurpassable scenes of outdoor beauty and grandeur. It will not be long before the tourist from any State of the Union can cover the distance from Alaska, California, and on down through to Mexico City, in a single

trip, and over the longest motor highway on the North American Continent. Both Alaska and Mexico contain magnificent scenic possibilities, and high in that scale are the mountain highways, and included in such a journey will be California's superb system of lofty flung roadways, modernized in all respects, and extending through miles of splendid scenery.

Twenty-five years ago mountain highway construction was in its infancy; today it is progressing by leaps and bounds; a quarter of a century hence will find it binding two Continents with links of concrete and asphalt, when North and South America will have joined hands and lands in a renaissance of mutual interest, and peace between the countries will be then more solidly welded than even in these days that greet us now.

WORLD'S FAIR BUILDERS — Lewis P. Hobart

DEEP holes will be worn in the pavements of the East Courts on Treasure Island during the World's Fair next year, by the shuffling feet of photographers who are snapping the arcades of the Court of Flowers through the Arch of Triumph; the pools of the Court of Reflections through the Arch of Triumph, and their dear old Aunt Mary standing in the Arch of Triumph.

All these photographers, and the workmen who patch the holes in the pavements, can thank Lewis P. Hobart for one of the classic photographic "frames" on the island, and for the courts on either side of it. He designed them all, and this main east-west axis of the Fair is one of the strongholds of glamour in the Golden Gate International Exposition's architecture.

Lewis Hobart was born in St. Louis, Mo., but he spent his boyhood in California, somehow acquiring a taste for architecture to the exclusion of all other professions. He was never in any doubt about it. After a year at the University of California he went to Italy, where he studied two years in the Architectural School at Rome. His next stop was Paris for three years, with study at the Ecole des Beaux-Arts.

From Paris he came to New York, where he opened his own office in 1905. Next year came the San Francisco fire, an event of far-reaching architectural significance; Lewis Hobart yielded to an urge he had felt for some while, and returned to San Francisco to establish himself in his favorite environment.

Since then the city's skyline has taken on a definite Hobart contour. Outstanding examples of his design are the Mills Tower, Grace Cathedral, Temple Methodist Episcopal Church and William Taylor Hotel (now the Empire), Fireman's Fund Insurance Building, University of California Hospital, Bohemian Club and San



MR. LEWIS P. HOBART THINKS TWICE

Francisco Zoological Gardens — which latter did not materially affect the skyline. Remote from San Francisco, the Hobart touch is seen in the Hotel Del Monte and the United States Post Office at Portland, Oregon.

Hobart was elected the first President of the Art Commission of the City and County of San Francisco, when it was established in 1932. Somehow he had escaped the Panama-Pacific International Exposition in 1915, but the Golden Gate of 1939 got him—got him on its Architectural Commission, that is to say. His Court of Flowers captivated the Bureau of

Horticulture instantly, with its cascades of Paul Scarlet roses showering down from niches around the walls, over the arcades.

So the horticulturalists junked the carpenters' name for it—East Square Court—and called it Flowers from Heaven. Astronomers denied the truth of this assertion, cited its physical location, and all but named it Court of the Sunrise. A confused publicity department was calling it the Court of Names when the Committee on Naming decreed Court of Flowers, which stuck. It's a lovely court.

So is the adjacent Court of Reflections, in which the electricians will surpass themselves with floodlighting, and between the two is the Arch of Triumph—the perfect frame for photographs. Returning to Mr. Hobart, their creator, he is a member of the American Institute of Architects, Society of Beaux-Arts Architects, and the American Academy at Rome.

EARLY AMERICAN ARCHITECTURE

(Concluded from Page 24)

ton Pratt & Co. for the State Capitol this day and daily for the last month, Mr. Pratt and myself came to a personal conflict on the stagings of the building. I had during the morning been employed in throwing from the stagings a large quantity of soft and very bad bricks, and had also thrown over some portions of walls which had been built with said bad bricks in the midst of which occupation Mr. Pratt came suddenly up to me in a hostile attitude and at the same time using menacing words and expressions, at which I became enraged and struck at Pratt. A general contest then commenced and blows were passed without much damage however, to either party.

"On the morning of the 4th inst the Mayor of Baton Rouge had us both arrested for disorderly conduct and tried. He fined me \$10 and \$3 cost because I struck the first blow. He

fined Pratt \$3 cost and discharged us without comment. Thus terminated the affair for the present at least.

"Mr. Pratt had for some time past showed the most abandoned spirit of villiany in furnishing bricks for the Capitol, which would all have been avoided had any of the other partners been present, but unfortunately they were all off in Kentucky or elsewhere, and Pratt alone managed the contract. He manifested such a faithless and dishonest disposition in the matter and appeared to be determined to persist, notwithstanding all our complaints or protests."

In another portion of the diary, Dakin tells of the difficulty in procuring Quincy granite and Cape Girardeau marble from eastern quarries. He finally terminated the contract and replaced much of the granite foundation with wrought iron.

What Mark Twain termed "an architectural monstrosity" when he first sighted the old Capitol from a steamboat on the Mississippi River, was referred to with a great deal of pride by the architect as "Castellated Gothic."

Dakin said in his original submission of plans: "I have used the 'Castellated Gothic' style of architecture in this design because it is quite as appropriate as any other style or mode of building and because no style or order of architecture can be employed which would give suitable character to a building with so little cost as this . . . Should a design be adopted in the Grecian or Roman order of architecture, we should accomplish only what unavoidably would appear to be a mere copy of some other edifice already erected and often repeated in every city and town of our country."

The recently discovered diary will be placed in the museum at Louisiana State University. Historians say that this document is one of the few having to do with the life of Dakin and it will form a nucleus for a collection of the papers of this pioneer architect and builder.

STANDARD ACCOUNTING SYSTEM FOR ARCHITECTS

By IRVING F. MORROW, Architect

I knew an architect of parts
Impelled by twofold aims, amounting
To joint allegiance to the arts
And scientific cost accounting.

His love of sketching, though intense,
Could not outweigh a predilection
To pause and calculate expense
Of paints and things of like complexion.

In office work—design, detail,
Specification, engineering—
No criticism could assail
His careful plans and skillful steering.

The one necessity he lacked
In office practice was a system
Designed to register each fact
On profits as he made or missed 'em.

One day the morning's mail disclosed
A pamphlet tuned to his obsession,
Wherein the A.I.A. exposed
A standard scheme for the profession.

It told how a committee solved
The problems posed by each condition,
Perfecting all details involved
By research touched with intuition.

Its sample forms revealed, it seemed,
Discretely tinted, ruled and centered,
More columns than he'd ever dreamed
For lines of figures to be entered.

Straightway he forwarded demands
For handbooks, ledgers, forms and journals,
Enriched with monel metal bands
And cowhide leather for externals.

Though with discount at members' rate
They totalled to a pretty penny,
This system now would compensate
For fiscal years he hadn't any.

He read the Manual, in fine,
For explanation and instruction,
And learned to recognize the line
'Twixt loss and capital deduction.

He chose a page with childish glee—
Which one it really didn't matter—
And, adding columns two and three
Took some percentage of the latter.

When he received or wrote a check
The problem of its proper entry
Reduced him to a nervous wreck,
Distracted by notions argument'ry.

He dreamed of balance sheets flung free,
Where syntheses of many facets
Revealed supine equality
Of liabilities and assets.

As time went on (which time will do
Despite the best-intentioned talents)
A shift of accent overthrew
His heretofore unerring balance.

The drafting board's dominion waned;
His interests foresook creation;
One sole reality remained—
The mysteries of tabulation.

One morning those who neared his door
Were startled by suspicious grumbings,
And found him seated on the floor
Engrossed in incoherent mumbings.

Through tones monotonously dull
Emerged, amid his ramblings myriad,
Such words as "fees," "receivable,"
"Net worth," "accrued," "accounting period."

Around him on the floor there lay
The Manual and loose-leaf folders
Arranged in orderly array
With reams of forms and gold-stamped holders.

The Standard System smoothly flowed—
No detail lacking, nothing twisted—
Although his check stubs clearly showed
No money to account existed.

To date, with maniacal bent
He languishes in sole confinement,
A monument to good intent
Diverted from humane alignment.

Pacific Coast Architects' Chapters

ANNUAL SUMMER OUTING

The annual summer outing of Southern California Chapter, American Institute of Architects, was held at the Flintridge Riding Club July 12, about 25 members and guests attending. Eugene Weston, Jr., president of the Chapter, presided.

A report of the progress being made by the committee in charge of publishing the volume of photographs of last year's honor awards, sponsored by the Chapter, was made by Paul Robinson Hunter.

William H. Harrison, chairman of the honor awards committee for 1938, stated that plans for this year's competition are already well advanced. Buildings, other than single family residences, are to be submitted to the jury, the personnel of which will be announced later. Other members of the committee are Herbert J. Powell, Arthur R. Hutchason, David C. Allison and Gordon B. Kaufmann.

Plans for the International Housing Congress in Mexico City this month were announced by Lloyd Wright.

The September meeting of the Chapter will be the annual social meeting and will be held at the Huntington Library in San Marino.

WASHINGTON STATE CHAPTER

Thirty-four architects and draftsmen attended the June meeting of Washington State Chapter, A.I.A., as guests of the Tacoma Society of Architects. Neison J. Morrison, vice-president of the Washington Chapter, officiated as chairman of the day. The report of the housing committee on multiple housing financing as provided under Sections 207 and 210 of the amended F.H.A. Act, was presented by George Wellington Stoddard, who discussed methods of procedure. He explained the proposed multiple housing enabling act to be presented to the next Washington State Legislature. George Gove outlined Tacoma's problem in the line of multiple housing.

The report of the civic design committee, proposing a city planning commission for Seattle, was presented by Carl F. Gould. The ensuing discussion included a similar commission for Tacoma and Pierce County.

Mr. Gould urged that a new committee be appointed to confer with the New York Fair Commission regarding the selection of a Washington architect to design the Washington State building at the fair. He suggested that the Washington State Progress Commission hold a competition for the selection of an architect.

FOUNTAINS ON TREASURE ISLAND

Fountains, among the oldest architectural entities in the world, will grace the 1939 Golden Gate International Exposition on San Francisco Bay with matchless beauty. These are now being prepared on Treasure Island, the man-made site of the World's Fair of the West.

One of the loveliest fountains will be found in the Court of Pacifica, designed by Timothy L. Pflueger. To the east of The Western Gateway, the entrance opposite the main ferry terminal, this fountain, operated by three pumps, has a capacity of 92,000 gallons of water.

Surrounding the sunken basin of this fountain, and on the fountain itself, are pieces of sculpture fashioned by such artists as Jacques Schnier, whose male and female statues symbolize the spirit of India; Brents Carlton, with a Polynesian group; Sargent Johnson's Inca Indians; Carl George's figures of North American Indian women; the statues of Adaline Kent which are symbolical of the Islands of the Pacific; a North American group by Ruth C. Wakefield; a South American group by Cecilia Graham, and a Chinese group by Helen Phillips.

"Movement and life will predominate at this fountain," explained J. E. Stanton, the Exposition's color expert. "Colored lights concealed beneath the water will play on the cascading waters, giving them an ever-changing rainbow of colors."

Looking down on the fountain from the north will be the gigantic statue of "Pacifica," fashioned by Ralph Stackpole. From the base of this statue a cascade of water, also brilliantly illuminated, will flow into the fountain.

To enhance the beauty of this fountain, the horticultural division of the Exposition under Julius L. Girod will feature such blooms as the new yellow tulips perfected by the De Graaf brothers of Holland; the blue veronica autumn glory, something new in the floral world, and masses of green creeping juniper.

Five fountains will be found in the Court of the Flowers, designed by Lewis P. Hobart. The largest of these rises from a circular basin just beyond the Triumphal Arch which is between the Court of the Flowers and the Court of Reflections, both of which are to the east of the Tower of the Sun. This fountain has a capacity of 158,000 gallons of water.

The dominating piece of sculpture for this fountain was fashioned by O. C. Malmquist, as were the lesser figures around the base. The main figure is that of a woman, which is called "The Rainbow." Figures of mermaids, seals and other denizens of the sea are to be placed around the base of the main fountain. In

each corner of the court, close to the arcades of the surrounding buildings, will be four smaller fountains. Here, too, illumination engineers will paint the arching waters with brilliant hues.

Surrounding this beautiful main fountain in the Court of Flowers will be solid beds of euonymus, a golden bloom; gunnera manicata, a tropical plant with leaves six to eight feet in diameter, and birds of paradise, flowers of golden yellow with brilliant blue trimmings.

In the Court of Honor, designed by Arthur Brown, Jr., there will be four smaller fountains with a combined capacity of 100,000 gallons. Fountains in this court necessarily are less heroic than those in other courts, because of the dominating Tower of the Sun rising from its center, and because visitors will spill into this area from the main entrance.

Striving for a new and spectacular effect, engineers, in planning the fountain for the South Gardens, have succeeded in shooting what are called "long drops" from the fountain jets. These create the illusion of the drops of water falling and rising simultaneously and will be a rare sight when flooded by colored lights.

LANDSCAPE ARCHITECTS' FEES

Representatives of the American Society of Landscape Architects have approved the following schedule of "Minimum Fees for Landscape Architects' Services (including supervision) on Housing Projects":

Landscape Construction (Estimated Normal cost)	Landscape Architect's Minimum Fee	
	% of Estimated Cost	Minimum Lump Sum Fee
Below \$10,000	10% plus \$450 (for supervision)	10% plus \$450
\$ 10,000	12.5%	\$ 1,250
15,000	10.8%	1,620
20,000	10.4%	2,030
30,000	9.8%	2,940
40,000	9.3%	3,720
50,000	9.0%	4,500
75,000	8.4%	6,300
100,000	8.0%	8,000
125,000	7.7%	9,625
150,000	7.5%	11,250
175,000	7.3%	12,775
200,000	7.2%	14,400
250,000	7.0%	17,500
300,000	6.8%	20,400
350,000	6.7%	23,450
400,000	6.6%	26,400
450,000	6.5%	29,250
500,000	6.4%	32,000

Representatives of the A.S.L.A. consider the following items of work, on housing projects, to involve costs on the basis of which the landscape architect computes his lump sum fee, in accordance with the A.S.L.A. "Schedule of Minimum Fees for Landscape Architects'

Services (including supervision) on Housing Projects."

Excavation*, grading, walks, fences and walls for recreation areas, drainage affecting lawns and recreation areas, water supply for irrigation, lawns, recreation areas, playground equipment, pools and planting.

*Extent of excavation. (It is the understanding of the United States Housing Authority that "the extent of excavation" refers to the part of the cost of excavation which shall be used in calculating the landscape architect's fee and which shall be determined by agreement in each case, based on the degree to which the excavated material is used in fills for which the landscape architect makes grading plans.)

HUGE L. A. BUILDING PROJECT

Construction of the largest rental housing project ever undertaken by private ownership in the nation will be launched in Los Angeles within the next sixty days, according to Harry Bennett, representing the D. Herbert Hostetter Estate.

The project involves more than \$6,000,000, the building site being a 72½ acre tract located on the east side of Los Angeles, between East Eighth and East Olympic Streets and extending from Soto Street to Grande Vista.

The project provides for the construction of 142 two-story residence apartments with 1102 living units, divided into three, four and one-half, and six room apartments and a total of 4443 rooms. Each unit will have its own front and rear entrance except some of the smaller units.

In the new project nearly 50 per cent of the total area of 72½ acres will be devoted to gardens and landscaping, and children's play yards with sand boxes, swings and other recreational facilities.

In conjunction with the residential development, it is planned to erect a retail shopping district controlled to conform with the general plan. Witmer & Watson are the architects.

The project is being undertaken by the estate of D. Herbert Hostetter, on a site which constitutes a portion of a 350 acre tract which has been owned by the Hostetter family for more than fifty years.

ARCHITECTURAL COMPETITION

The government of El Salvador is planning to erect new university buildings at a cost of \$1,000,000. Announcement has been made of an architectural competition with a first prize of \$1500 and a second prize of \$500. The architectural designs must be received at the Secretariat of the University of El Salvador not later than noon, October 31st. Under the terms of the competition the prize winning designs become the property of the University.

Further details with reference to the competition may be secured by writing to the Director General of the Pan American Union, Washington, D.C.

With the Architects

SUMMER RESORT BUILDINGS

A boat house and store building is being designed by Architect J. K. Ballantine, San Francisco, for C. Rocca, Echo Lake. The same architect has preliminary drawings under way for two apartment buildings to cost \$30,000 in San Mateo and for a \$20,000 residence for an unnamed client in Mill Valley.

CIVIC AUDITORIUM

Mark Daniels, 101 Post Street, San Francisco, is preparing the plans for a reinforced concrete civic auditorium at Santa Cruz, estimated to cost \$250,000. The structure will have a seating capacity of 2200. A P.W.A. grant has been approved and a bond issue will be held September 13th.

GILROY AUDITORIUM

A civic auditorium to cost approximately \$70,000 will be built at Gilroy, provided a P.W.A. grant is received. Messrs. Binder and Curtis have been retained as architects.

BERKELEY POLICE BUILDING

A police administration building to cost \$350,000 will be built adjoining the Berkeley City Hall if bonds carry. A P.W.A. grant for \$160,000 has already been approved. James W. Plachek is the architect.

BOTTLING PLANT

Albert R. Williams, 251 Post Street, San Francisco, has let a contract to W. C. Tait for construction of a \$25,000 one-story frame and steel bottling plant on San Bruno Avenue, San Francisco.

CAFE BUILDING

A contract has been awarded for \$40,000 for a 1 1/2 story frame and stucco cafe building and cocktail bar for F. Campiano at El Cerrito, from plans by E. Keith Narbett, of Richmond.

DIXON HIGH SCHOOL

Preliminary drawings have been prepared by W. G. Corlett, Bank of America Building, Oakland, for a one-story reinforced concrete high school building at Dixon, to cost \$210,000.

CITY HALL AND LIBRARY

Robert Stanton, Del Monte Hotel, Del Monte, has prepared preliminary drawings for a city hall and library at King City. A P.W.A. grant has been applied for.

BUSY WITH RESIDENCE WORK

New work in the office of Leo J. Sharpe, 1319 Howard Avenue, Burlingame, includes a \$12,000, nine-room residence in the Baywood Tract, San Mateo for F. A. Wisnom; a \$15,000, eight-room house in Hillsborough; and an eight-room house at Atherton for unnamed client.

SCHOOL ADDITION

Harry J. Devine, of Sacramento, has prepared preliminary plans for five classrooms and a gymnasium for the Grass Valley Union High School District; also a cafeteria, gymnasium and science building for the Placerville Union High School District, to cost \$100,000.

COURT HOUSE ANNEX

Plans have been completed by W. H. Toepke, Thos. Edwards and H. A. Schary of San Francisco for a \$240,000 court house annex at Redwood City. There will be three floors, two elevators, oak trim and gas steam heat.

ENJOYS EASTERN TRIP

Charles T. Pearson, president of the Tacoma Society of Architects and member of Lea, Pearson & Richards, 329 Tacoma Building, Tacoma, left for Chicago by train early in June. Returning, he drove home in a new motor car purchased in Chicago.

SCHOOL BONDS VOTED

Bonds for a \$200,000 school at Oakdale have been voted and working drawings are being completed by Architects Frank Mayo and Eric Johnson of Stockton. R. H. Cooley of Oakland is the structural engineer.

MEDICO DENTAL BUILDING

At Reno, Nevada, Dr. A. J. Hood will build a four-story Class A reinforced concrete and steel Medico-Dental building from plans by Architect Douglas D. Stone, 381 Bush Street, San Francisco.

LARKSPUR FIREHOUSE

Plans have been completed and construction started for a two-story frame and stucco firehouse at Larkspur, Sam Heiman, 605 Market Street, San Francisco, architect. The building will cost \$20,000.

SCHOOL BUILDING ADDITION

A \$45,000 addition is planned for the Calistoga Joint Union High School. The improvement will consist of a gymnasium and shop building. Wm. Herbert is the architect.

NEW CONDITIONS IN HOUSING

LARGE-SCALE housing promises to develop a new technique of town building, attracting the best minds in the profession of architecture, Sir Raymond Unwin, British housing authority, says in a report on "The Housing Problem" appearing in "The Octagon," publication of the American Institute of Architects.

"Hitherto, able architects have been mainly interested in the few larger commercial, industrial and cultural buildings, and have left to the speculative builder the designing of houses which, though small and relatively unimportant individually, generally occupy from 80 to 85 per cent of the area of the town and very largely determine its character and appearance," Sir Raymond points out.

"If the building of small dwellings is to be undertaken on a large scale by public authorities quite new conditions arise. Although each individual house may be a small matter, the planning, design, and building of a large scale housing scheme, covering a wide area of land, becomes a very important undertaking; one which should command the highest skill and which offers scope in design sufficient to inspire the ablest architects.

"There is another aspect of special interest to architects. The planning of large scale housing projects undoubtedly tends to release the scope of design from the single building, to which it has for long been too much confined, to a wider field of relations. The scope is extended to the grouping of buildings, to the relations of differing groups to each other, to the system of streets, to open spaces, and to the neighborhood as a whole.

"This may well be the beginning of a new technique of town building through which escape may be found from the muddle and confusion which have mainly prevailed during the last century and has been the chief cause or excuse for that undue concentration of attention and design on the individual building, which by ignoring any wider relations has too often increased the confusion.

"Architects have so long endured this fate of being set to design single buildings which may be flanked on each side by others of the most divergent and incongruous character, without even the protection of the gilt frame which the picture artist enjoys, that they seem often to have ceased themselves to have any consideration for the neighboring buildings. Instead of producing a note of harmony with them, they seem rather to utter a fresh loud note, which, however fine and pure in itself, can but produce the jangle of discord when combined with those uttered by the two adjacent neighbors."

Development of housing for the lower income groups on a large scale by public authorities offers a great opportunity for raising the standard of planning and design in the urban residential areas, according to Sir Raymond.

"Commencing at the bottom of the scale of size and cost of the dwellings, where the special difficulties are being surmounted by public aid, if this section is well laid out and designed, a standard will be set which must spread upward, and this may well prove the first step in the redemption of modern towns from the degraded muddle of ill-assorted buildings into which they have fallen," he explained.

"If, however, architects are to make to this movement the contribution which they might, and to take advantage of the fine opportunities for town improvement which it offers, they must understand the problem and its conditions, otherwise they will be unable to cooperate intelligently in securing the best solution, the best architecturally as well as socially and economically."

America is now faced with the urgent need to find an effective solution for the serious housing problem, Sir Raymond declares. "The position," he adds, "is aggravated by the tendency to overlook the fact that when the rate of increase in a population diminishes the number of families per thousand of the population increases.

"There is a tendency to estimate the housing need in terms of the small increase in the number of persons, whereas it is the increase in the number of families which measures the need of dwellings. Now the falling off in the rate of increase in a population generally implies a diminution in the average size of the families, so that for a considerable period a small increase in people may be accompanied by a large increase in families.

"In England, for example, in the decade 1921 to 1931 while the population only increased 5.5 per cent, the number of families increased 17.1 per cent, or more than three times as fast. This means that the increase in number of dwellings needed would be 17 per cent, not 5 per cent. This tendency is affecting the conditions in the United States, and must greatly aggravate the shortage due to the small amount of house building during the recent years of depression."

GOLDEN GATE FAIR BUILDING

Architects McClelland & Jones, Republic Building, Seattle, have been retained by the Owl Drug Co. to prepare plans for a \$150,000 drug store building to be erected at the Golden Gate Exposition on Treasure Island.

ARCHITECTS' BULLETIN

Issued For

THE STATE ASSOCIATION OF CALIFORNIA ARCHITECTS Northern Section

STATE ASSOCIATION MEMBER
OF THE
AMERICAN INSTITUTE OF ARCHITECTS

Editor
Harris C. Allen

Address all communications for publication
of the Bulletin to the Editor (Harris C.
Allen) 557 Market Street, Room 218, San
Francisco, California.

Board of Control
Harris C. Allen Otto G. Hintermann
Henry Michelson Ellsworth E. Johnson
Chester H. Miller

State Association Officers
Henry M. Michelson, San Francisco, President
George D. Riddle, Los Angeles, Vice-Pres.
E. N. Crawford, Santa Maria, Secretary
Otto G. Hintermann, San Francisco, Treas.

Regional Director, A. I. A.
Albert J. Evers, San Francisco

**Representative of Regional Director,
Southern California**
Gordon B. Kaufmann, Los Angeles

Executive Board—Northern Section Officers

Henry M. Michelson.....President
Gordon B. Kaufmann.....Vice-President
Ellsworth E. Johnson.....Secretary
Otto G. Hintermann.....Treasurer

Directors

Walter E. Baumberger William G. Merchant
Henry J. Devine Frederick H. Reimers

Executive Board—Southern Section Officers

George D. Riddle.....President
Gordon B. Kaufmann.....Vice-President
E. N. Crawford.....Secretary
Walter H. Orr.....Treasurer

Directors

Walter C. Chambers Lester G. Hibbard
W. M. Edelman W. P. Lodge
S. B. Marston

Advisors—Northern Section

Harris C. Allen Edward R. French, Jr.
F. Ashley Arthur F. Dodman
L. Ballantine Joseph Losekann
Elyse S. Hertzka David H. Horn
Brad T. Kett Robert Stanton
William I. Garren Charles S. McKenzie
G. Merchant Henry C. Collins
Thomas E. Pring Leo J. Sharps
Vincent Raney Carl F. Gromme
H. Reimers C. C. Dakin
George O. Blodgett F. T. Georgeson
Ward P. Simonds Ralph D. Taylor
Henry M. Michelson, Northern Section
Secretary

STATE CONVENTION

PLANS for the annual convention are developing rapidly. Arrangements have been made with the Fairmont Hotel, San Francisco, for all necessary accommodations and for attractive convention hotel rates, details of which, together with other specific information, will be sent members in due time.

The tentative program has been established as follows:

Thursday, October 13th:

Joint meetings of Executive Board and State Board of Architectural Examiners.

Stag Dinner, 6 to 8 P.M., for board members, advisors, committee chairman; this will be open to all other members who wish to attend or have any subjects to submit to the board for their final meeting Thursday night.

Friday, October 14th:

Convention convened, with usual business and Board reports.

Special program, starting with a convention luncheon featuring special speaker and continuing Friday afternoon with prepared and open forums.

Hospitality Hour, followed by convention banquet, in the form of a dinner dance with pageant and special entertainment features.

Saturday, October 15th:

Morning session with report of resolutions committee and convention action on all resolutions; election of officers; and adjournment.

There will be no golf tournament, but a special committee will arrange golf games for private groups on Saturday afternoon and Sunday morning.

A trip to Treasure Island will be arranged for delegates and ladies for Saturday afternoon.

An architectural exhibit is being planned by the Northern California Chapter of the Institute, which will be open during the convention at the San Francisco Art Gallery in the Veterans' Building, Civic Center.

The general convention committee consists of John K. Ballantine, chairman; Otto G. Hintermann, Harris C. Allen, William I. Garren and Roland I. Stringham.

Special committee chairmen are: Reception and Registration, Lester W. Hurd; Resolutions, Gwynn Officer; Program, Vincent Raney; Entertainment, Harris C. Allen; Publicity, Ellsworth E. Johnson; Golden Gate Exposition Trip, William G. Merchant; Finance, Otto G. Hintermann.

FEE SCHEDULE

A schedule of approved fees for architects on different classes of work, which was determined by executive boards and Institute Chapters in both Northern and Southern Sections several years ago, is now to be issued in printed leaflet form, by order of the executive board. This will be available at cost to all members for information to their clients.

PUBLIC BUILDINGS

Architects throughout the state are advised to inform the State Association of California Architects office of any proposed new public build-

ings, schools, etc., in order that the proper authorities may be communicated with, in regard to correct procedure, fees, etc. The Association has a number of copies of an excellent brochure "Advice in the Planning of Public Buildings" which was prepared by a former Public Information Committee, headed by Henry Collins, and which can be of practical assistance to Boards of Education, School Superintendents, and other public officials.

BUILDING CONGRESS

Our indefatigable president, Harry Michelsen, has accepted the chairmanship of the California Building Congress, Northern Section, of the State Chamber of Commerce. This is in line with his well known determination to put the architectural profession in the forefront of closer organization of the building industry in its various branches.

ABOUT DRAFTSMEN

Stanford White was at one time showing visitors about his office and one of them said with courteous interest: "How many draftsmen do you employ, Mr. White?" To which the great architect replied: "One hundred and ten—one hundred in the drafting-rooms and ten in the toilets."

* * *

To Jack Frost, of Bennett, Parsons and Frost is attributed the following: When he was a young draftsman in a certain architectural office, someone asked him how he was getting along with a drawing that had been assigned to him. "It's almost finished," he replied, "I have it all in my head, all I have to do is draw it."

* * *

Anonymous: "I wish you fellows wouldn't make so much noise; I might hear it strike five o'clock."

* * *

Head-draftsman stuff: "When a man is absent from his board, I place my hand on the seat of his chair. If it is still warm, I know he has not been gone an unreasonable length of time." —Federal Architect.

STEEL RAILROAD BRIDGE

Construction of the first unit of the permanent Southern Pacific railroad relocation around the Shasta Reservoir site is expected to get under way this summer with the building of a steel railroad bridge across the Sacramento River at Redding, California.

The bridge will be four-fifths of a mile long, most of it on a curve leading from the cliffs at the northerly edge of Redding, across the river channel and adjacent lowlands toward the foothills. The three river spans will total about 400 feet in length. There will be 71 approach spans of from 35 to 80 feet each.

Walker R. Young, construction engineer of the Cen-

tral Valley Project, said the bridge work will be divided into two schedules. One schedule will cover the construction of reinforced concrete abutments and piers, and alterations to Riverside Drive in Redding under the south end of the bridge. The other schedule will cover the furnishing, erecting and painting of the steel superstructure, construction of a timber deck, and laying of the track.

The specifications provide that the substructure shall be completed within 330 days and the superstructure within 430 days from the date of the Government's notice to proceed with construction.

The existing Southern Pacific line between San Francisco and Portland, Ore. goes up the Sacramento River Canyon past the Shasta Dam site and through the reservoir site. Thirty-seven miles of the present line are to be replaced by 30 miles of new line between Redding and Delta, Shasta County, at an elevation above the high water level of the future reservoir.

Commissioner of Reclamation John C. Page has announced that agreement has been reached between the Southern Pacific Company and the Government upon all principal points regarding the relocation, and that it remains only for the necessary contracts to be completed in detail for signature. The Bureau of Reclamation is to contract the work of excavation, grading, tunneling and bridge building for the new line. The Southern Pacific is to lay the track and install its block signal system, and will be reimbursed by the Government on a cost basis.

The start of work on Shasta Dam itself will not have to await completion of the new railroad, for an 1880-foot diversion tunnel, contract for which has been awarded, is to be bored through the west abutment of the dam site and will be used temporarily for carrying trains past the scene of dam construction. When the thirty-mile railroad line is completed and opened to traffic, the canyon tunnel will be used to divert the flow of the Sacramento River past the dam site during the second stage of dam construction.

BOOK ON STRUCTURAL INSULATION

A new twelve-page book in colors describing the uses of structural insulation in home building has recently been prepared by The Insulite Company. The book, entitled "Increasing Home Enjoyment with Insulite," explains in layman's language the benefits which the company claims are offered to users of their products.

Of interest to architects is a section in the book devoted to the theory of Balanced Insulation. A chart is used to show the advantages of distributing insulation equally over the entire wall area of a home.

Copies of this book may be obtained by writing to The Insulite Company, Minneapolis, Minnesota.

Structural Engineers Association of Northern California

OFFICERS

Harold B. Hammill, President

S. S. Gorman, Vice President

H. M. Engle, Secretary-Treasurer

Other Directors:

F. F. Hall

A. V. Saph, Jr.

ENGINEERING PROBLEMS OF G. G. EXPOSITION

"A Modern Exposition—Its Engineering Problems and Their Solution" was the subject of technical discussion at the August 2nd meeting of the Structural Engineers' Association of Northern California, at the Engineers' Club in San Francisco.

The speakers were W. P. Day, Vice-President and Director of Works of the Golden Gate International Exposition, and John J. Gould, Chief of the Division of Structural Engineering, both of whom are members of the Association.

Mr. Day presented the general engineering problems encountered in the design and construction of the Exposition, and also gave a brief resume of the accomplishments of the various divisions in his department. He disclosed that a new development in the electric lighting field will be used commercially for the first time on the fair grounds. This light, developed in the laboratories of the General Electric Company, consists of long glass tubes filled with argon and chemically coated on the inside. When the current is turned on the tubes glow with a soft colored luminosity. An almost unlimited color palette is possible by using different chemicals for the inside coating.

The tree planting program is nearing completion. Because of the large number of huge trees and the difficulty in transporting them, the work is on the order of a major engineering project. It is being done by the Exposition Company at a substantial saving over earlier competitive bids. As this work is being completed roads are being laid and surfaced. The road-work had to wait on the completion of the above program so that the heavy duty equipment used in moving the trees would not damage the pavements.

Lagoons are being lined with a sand clay material which is deposited in layers and rolled and compacted to a final thickness of 10".

Mr. Gould discussed the features of the structural design and some of the methods used in their solution. One of the points discussed was the use of diagonal sheathing diaphragms carrying unusually high shears. Contrary to usual practice the details at all points of these diaphragms were designed to withstand all stresses which were calculated to exist under a rigorous analysis.

Because of the nature of the green fill material, piling was indicated as the best solution for the foundations of the slender 400' high Tower of the Sun. Borings showed

that 90' pile lengths were needed and of these 224 were used. The piles were concentrated mainly at the rim of a huge reinforced concrete wheel with 8 spokes. This conformed to the octagonal plan of the tower. Thus far, no settlement has been observed in this tower.

An interesting detail was pointed out where 5 members meet at the point at the inside corner of a 3 hinged arch. All members carry heavy compressions and only minor tensions under maximum lateral loads. A 12" thick concrete prism was poured in the space between the ends of the 5 timber members at this joint and the 2 steel side gusset plates. This block contains 2½ cu. ft. of concrete, is reinforced and is connected by bolts to the steel plates. The compressive forces are transmitted through the concrete prism, tensile forces pass through the steel gussets.

In the Hall of Western States the structural elements were a part of the architectural treatment. Three-hinged diagonal sheathed arches were used here. Long span 36' joists were exposed. Plywood walls were used in lieu of plaster board and also to resist lateral forces.

At the conclusion of the speakers' remarks, questions were asked from the floor and lively discussions were entered into.

Get-Together Meeting in Oakland

George Washington is marshalling his forces and promises a variety of program to interest every phase of association membership. A large attendance is expected at this Oakland gathering.

Joint Architects Meeting

J. E. Mackie is cooperating with the architectural societies of the Bay area to make the joint meeting of structural engineers and architects on September 6th the best ever held. Main topic will be one of great interest to every member of both professions.

October Annual Convention

Date and place not yet determined. (Probably Santa Barbara.) Our Southern members are arranging the program. Northern Section will have charge of the entertainment features of the affair, which after all are the most important. Those who took their wives last year will remember the big event put on by one of our own members.

WE'RE ON THE SPOT!

BUT WHAT A SPOT . . . the only Professional Architectural and Building Publication of Coast-wide Coverage . . . in the Whitest Spot in the Nation's Building Industry.

35% of the F. H. A. mortgage loans insured during the first seven months of this year were in the Pacific Coast States — California, Oregon and Washington. During the same period, the Northern California office of the F. H. A. has approved more loans on new home construction than during the entire twelve months of 1937 . . . 4,845 new homes at a total cost of \$23,890,000 were approved during 1937 and 6,372 homes totaling \$30,677,000 for this year, with five months to go. The total to date is more than the combined figure for the two years 1935 and 1936.

Here is the most important concentrated market for building materials and supplies in the nation today. And here is a publication that covers this field like the proverbial blanket, sponsored and endorsed by the State Association of California Architects, in an authoritative position of reader interest and confidence earned through more than three decades of valued service to the architectural and building profession . . . a logical and profitable advertising medium for producers of building equipment and materials.

The ARCHITECT and ENGINEER

68 POST STREET • SAN FRANCISCO

Thirty-third Year of Continuous Publication

Estimator's Guide

Living Cost of Building Materials, Wage Scale, Etc.

Amounts given are figuring prices and are made up from average quotations furnished by material houses to San Francisco contractors. 3% Sales Tax on all materials but not labor.

prices and wages quoted are for San Francisco and the Bay District. There may be fluctuation of prices in the interior southern part of the state. Freight charge, at least, must be added in figuring any work.

-1/2% amount of contract.

work—
Common, \$40 to \$45 per 1000 laid, (according to class of work).

ce, \$100 to \$110 per 1000 laid, (according to class of work).

ck Steps, using pressed brick, \$1.25 in. ft.

ck Veneer on frame buildings, \$.75 sq. ft.

Common f.o.b. cars, \$14.00 at yard. Cartage extra.

ce, f.o.b. cars, \$45.00 to \$50.00 per 1000, carload lots.

OW TILE FIREPROOFING (f.o.b. job)

2x12 in. \$ 84.00 per M
2x12 in. 94.50 per M
2x12 in. 126.00 per M
2x12 in. 225.00 per M

OW BUILDING TILE (f.o.b. job)

load lots.
2x5 1/2 \$ 94.50
2x5 1/2 73.50

ing Paper—

ly per 1000 ft. roll \$3.50
ly per 1000 ft. roll 5.00
ly per 1000 ft. roll 6.25
wskinn, 500 ft. roll 4.50
wskinn, Protect-o-mat, 1000 ft. roll 9.00
lkraft, 500 ft. roll 5.00
cord com. No. 7 \$1.20 per 100 ft.
cord com. No. 8 1.90 per 100 ft.
cord spot No. 7 1.90 per 100 ft.
cord spot No. 8 2.25 per 100 ft.
weights cast iron, \$50.00 ton.
s, \$3.50 base.
weights, \$45 per ton.

crete Work (material at San Francisco
bunkers)—Quotations below 2000 lbs. to
ton. \$2.00 delivered.

3, 3 rock, at bunkers.....\$1.45 per ton

4, 4 rock, at bunkers..... 1.45 per ton

lott top gravel, at bunkers 2.10 per ton

ashed gravel, at bunkers.... 1.45 per ton

lott top gravel, at bunkers 2.10 per ton

ly gravel, at bunkers..... 1.45 per ton

ver sand, at bunkers..... 1.40 per ton

livered bank sand..... 1.00 cu. yd.

—Above prices are subject to discount
2% per ton on invoices paid on or be-
fore the 10th of month, following delivery.

D
Monte, \$1.75 to \$3.00 per ton.
n Shell Beach (car lots, f.o.b. Lake Ma-
jella), \$2.75 to \$4.00 per ton.

Cement (paper sacks) \$3.00 bbl., ware-
house or delivery.

Car-load lots delivered \$2.70, f.o.b. cars
\$2.52

(Cloth sacks) \$3.00 bbl..

Rebate 10 cents bbl. cash in 15 days.

(1 to 100 sacks, \$1.50 sack.
warehouse or delivery; over 100
Atlas White) sacks, \$1.25; 2% discount 10th
Calaveras White)
Medusa White) of month.

Forms, Labors average \$40.00 per M.

Average cost of concrete in place, exclu-
sive of forms, 35c per cu. ft.;
with forms, 60c.

4-inch concrete basement floor
..... 12 1/2c to 14c per sq. ft.

Rat-proofing 7 1/2c

Concrete Steps \$1.25 per lin. ft.

Dampproofing and Waterproofing—

Two-coat work, 20c per yard.

Membrane waterproofing—4 layers of sat-
urated felt, \$4.50 per square.

Hot coating work, \$1.80 per square.

Medusa Waterproofing, 15c per lb., San
Francisco Warehouse.

Tricocel waterproofing.

Electric Wiring—\$12.00 to \$15.00 per outlet
for conduit work (including switches).

Knob and tube average \$3.50 per outlet.

Elevators—

Prices vary according to capacity, speed
and type. Consult elevator companies.

Average cost of installing an automatic
elevator in four-story building, \$2800;
direct automatic, about \$2700.

Excavation—

Sand, 60 cents; clay or shale \$1 per yard.

Teams, \$12.00 per day.

Trucks, \$22 to \$27.50 per day.

Above figures are an average without
water. Steam shovel work in large quan-
tities, less; hard material, such as rock,
will run considerably more.

Fire Escapes—

Ten-foot galvanized iron balcony, with
stairs, \$115 installed on new buildings;
\$140 on old buildings.

Floors—

Composition Floors—22c to 40c per sq. ft.

In large quantities, 16c per sq. ft. laid.

Mosaic Floors—80c per sq. ft.

Duraflex Floor—23c to 30c sq. ft.

Rubber Tile—50c to 75c per sq. ft.

Terezo Floors—45c to 60c per sq. ft. *

Terezo Steps—\$1.60 lin. ft.

Hardwood Flooring (delivered to building)—

3 1/2" x 2 1/4" T & G Maple..... \$ 88.00 M ft.

1 1/2" x 2 1/4" T & G Maple..... 115.00 M ft.

7/8" x 3 1/2" sq. edge Maple..... 100.00 M ft.

	3 1/2" x 2 1/4"	3/4" x 2"	1 1/2" x 2"
	T & G	T & G	Sq. Ed.
Clr. Old. Oak.....	\$120.00 M	\$ 82.50 M	\$110 M
Sel. Old. Oak.....	99.00 M	69.50 M	84 M
Clr. Pla. Oak.....	106.00 M	74.50 M	86 M
Sel. Pla. Oak.....	97.00 M	62.50 M	76 M
Clear Maple.....	111.00 M	100.00 M	
Laying & Finishing	14c ft.	12c ft.	10c ft.
Wage—Floor layers, 100.00.			

Note—Above quotations are all board measure
except last column which is sq. ft.

Glass (consult with manufacturers)—

Double strength window glass, 20c per
square foot.

Plate 75c per square foot (unglazed) in
place, \$1.00.

Art, \$1.00 up per square foot.

Wire (for skylights), 40c per sq. foot.

Obscure glass, 30c square foot.

Glass bricks, \$2.40 per sq. ft., in place.

Note—If not stipulated add extra for set-
ting.

Heating—

Average, \$1.90 per sq. ft. of radiation
according to conditions.

Warm air (gravity) average \$40 per regis-
ter.

Forced air, average \$60 per register.

Iron—Cost of ornamental iron, cast iron
etc., depends on designs.

Lumber (prices delivered to bldg. site).

No. 1 common \$29.00 per M
No. 2 common 27.00 per M
Select O. P. common 34.00 per M
2x4 No. 3 form lumber..... 24.00 per M
1x4 No. 2 flooring VG..... 55.00 per M
1x4 No. 3 flooring VG..... 47.00 per M
1x6 No. 2 flooring VG..... 60.00 per M
1 1/4 x 4 and 6, No. 2 flooring..... 60.00 per M

Slash grain—

1x4 No. 2 flooring \$43.00 per M
1x4 No. 3 flooring 40.00 per M
No. 1 common run T. & G. 30.00 per M
Lath 5.25 per M

Shingles (add cartage to price quoted)—

Redwood, No. 1 \$1.10 per bdle.
Redwood, No. 290 per bdle.
Red Cedar 1.10 per bdle.

Millwork—Standard.

O. P. \$85.00 per 1000. R. W., \$90.00
per 1000 (delivered).

Double hung box window frames, average
with trim, \$6.50 end up, each.

Doors, including trim (single panel, 1 3/4
in. Oregon pine) \$8.00 and up, each.

Doors, including trim (five panel, 1 3/8 in.
Oregon pine) \$6.00, each.

Screen doors, \$3.50 each.

Patent screen windows, 25c a sq. ft.

Cases for kitchen pantries seven ft. high
per lineal ft., \$8.00 each.

Dining room cases, \$8.00 per lineal foot.

Rough end finish about 75c per sq. ft.

Labor—Rough carpentry, warehouse heavy
framing (average), \$17.50 per M.

For smaller work average, \$35.00 to \$45.00
per 1000.

Marble—(See Dealers)

Painting—

Two-coat work	36c per yard
Three-coat work	50c per yard
Cold Water Painting.....	10c per yard
Whitewashing	4c per yard
Turpentine, 65c per gal., in 5 gal. cans, and 55c per gal. in drums.	
Raw Linseed Oil—97c gal. in bbls.	
Boiled Linseed Oil—\$1.00 gal. in bbls.	
Mixed Portland Cement Paint, 20c per lb.	

Pioneer or Dutch Boy White Lead in Oil (in steel kegs).

	Per Lb.
1 ton lots, 100 lbs. net weight.....	10/4c
500 lbs. and less than 1 ton lots.....	10/2c
Less than 500 lb. lots.....	11c

Pioneer or Dutch Boy Red Lead and Litharge (in steel kegs).

1 ton lots, 100 lb. kegs, net weight.....	10/4c
500 lbs. and less than 1 ton lots.....	10/2c
Less than 500 lb. lots.....	11c

Pioneer Red Lead in Oil (in steel kegs)

1 ton lots, 100 lb. kegs, net weight.....	11/4c
500 lbs. and less than 1 ton lots.....	11/2c
Less than 500 lb. lots.....	12c

Note—Accessibility and conditions cause some variance in costs.

Patent Chimneys—

6-inch	\$1.25 lineal foot
8-inch	1.75 lineal foot
10-inch	2.25 lineal foot
12-inch	3.00 lineal foot

Plastering—Interior—

	Yard
1 coat, brown mortar only, wood lath.....	\$0.75
2 coats, lime mortar hard finish, wood lath.....	.80
2 coats, hard wall plaster, wood lath.....	.85

3 coats, metal lath and plaster.....	1.30
Keene cement on metal lath.....	1.30
Ceilings with 3/4 hot roll channels metal lath.....	1.75
Ceilings with 3/4 hot roll channels metal lath plastered.....	1.85
Single partition 3/4 channel lath 1 side.....	.50
Single partition 3/4 channel lath 2 sides 2 inches thick.....	1.50
4-inch double partition 3/4 channel lath 2 sides.....	1.30
4-inch double partition 3/4 channel lath 2 sides plastered.....	3.00

Plastering—Exterior—

2 coats cement finish, brick or concrete wall.....	\$1.00
2 coats Calaveras cement, brick or concrete wall.....	1.35
3 coats cement finish, No. 18 gauge wire mesh.....	1.50
3 coats Calaveras finish, No. 18 gauge wire mesh.....	1.75

Wood lath, \$7.50 to \$8.00 per 1000.....	
2.5-lb. metal lath (dipped).....	.17
2.5-lb. metal lath (galvanized).....	.20
3-lb. metal lath (dipped).....	.22
3-lb. metal lath (galvanized).....	.28
3/4-inch hot roll channels, \$72 per ton. Finish plaster, \$18.90 ton; in paper sacks. Dealer's commission, \$1.00 off above quotations. \$13.85 (rebate 10c sack).	
Lime, L. & B. warehouse, \$2.25 bbl.; cars, \$2.15 lime, bulk (ton 2000 lbs.), \$16.00 ton.	
Wall board 5 ply, \$50.00 per M.	
Hydrate Lime, \$19.50 ton.	

Plasterers Wage Scale \$1.25 per hour
 Hod Carriers Wage Scale 1.25 per hour
 Laborers Wage Scale 1.10 per hour
Composition Stucco—\$1.80 to \$2.00 sq. yard (applied).

Plumbing—

From \$70.00 per fixture up, according to grade, quantity and runs.

Roofing—

“Standard” tar and gravel, \$6.50 per sq. for 30 sqs. or over.
 Less than 30 sqs. \$7.00 per sq.
 Tile, \$20.00 to \$35.00 per square.
 Redwood Shingles, \$7.50 per square in place.
 Copper, \$16.50 to \$18.00 per sq. in place.

Cedar Shingles, \$8.00 per sq. in place.
 Recoot, with Gravel, \$3.00 per sq.
 Asbestos Shingles, \$15 to \$25 per sq. laid.
 Slate, from \$25.00 to \$60.00 per sq. laid according to color and thickness.

Sheet Metal—

Windows—Metal, \$1.75 a sq. foot.
 Fire doors (average), including hardware \$1.75 per sq. ft.

Skiylights—(not glazed)

Copper, 90c sq. ft. (flat).
 Galvanized iron, 30c sq. ft. (flat).
 Vented hip skylights 60c sq. ft.

Steel—Structural

\$120 ton (erected), this quotation is an average for comparatively small quantities. Light truss work higher. Plate beams and column work in large quantities \$90 to \$100 per ton.

Steel Reinforcing—

\$80.00 to \$120.00 per ton, set.

Stone—

Granite, average, \$6.50 cu. foot in place.
 Sandstone, average Blue, \$4.00. Boston \$3.00 sq. ft. in place.
 Indiana Limestone, \$2.80 per sq. ft. in place.

Store Fronts—

Copper sash bars for store fronts, corner center and around sides, will average 75c per lineal foot.
 Note—Consult with agents.

Tile—Floor, Wainscot, etc.—(See Dealer)

Asphalt Tile—18c to 28c per sq. ft. installed.

Venetian Blinds—

40c per square foot and up. Installation extra.

THE BUILDERS' EXCHANGE OF SAN FRANCISCO STANDARD WAGE SCALE

For mechanics employed on construction work in the Bay Region. Effective September 1, 1937

CRAFT	Journeymen Mechanics	CRAFT	Journeymen Mechanics	CRAFT	Journeymen Mechanics
Asbestos Workers	\$ 8.00	Laborers, Building (8h-5d)	\$ 6.00	Steam Fitters (8h-5d)	\$11
Bricklayers (8h-5d)	10.50	Laborers, Commercial (8h-5d)	6.00	Stair Builders (8h-5d)	9
Bricklayers' Hodcarriers (8h-5d)	6.75	Lathers, Channel Iron (8h-5d)	9.00	Stone Cutters, Soft and Granite (8h-5d)	8
Cabinet Workers (Outside) (5d)	8.00	Lathers, All Others	9.00	Stone Setters, Soft and Granite	12
Casson Workers (Open)	6.40	Marble Setters (8h-5d)	10.50	Stone Derricks	11
Carpenters (8h-5d)	10.00	Marble Setters' Helpers (8h-5d)	5.50	Tile Setters (8h-5d)	11
Cement Finishers (8h-5d)	9.00	Model Makers (\$1.50 per hr-6h)	9.00	Tile Setters' Helpers (8h-5d)	6
Cork Insulation Workers (8h-5d)	9.00	Modelers (\$2 per hr-6h)	12.00	Tile, Cork and Rubber (8h-5d)	9
Electric Workers (8h-5d)	11.00	Model Casters	7.20	Welders, Structural Steel Frame on Buildings	11
Electrical Fixture Hangers	8.00	Mosaic and Terrazzo Workers (Outside)	9.00	Welders, All Others on Buildings	11
Engineers, Portable & Hoisting	10.40	Painters (7h-5d)	8.50	Dump Truck Drivers, 2 yards or less	6
Elevator Constructors	9.00	Painters, Varnishers and Polishers (Outside)	9.00	Dump Truck Drivers, 3 yards	7
Engineers, Glass Workers (8h-5d)	9.68	Pile Drivers and Wharf Builders	9.00	Dump Truck Drivers, 4 yards	7
Hardwood Floormen	9.00	File Drivers' Engineers	10.00	Dump Truck Drivers, 5 yards	7
Housemiths, Architectural Iron (Shop) (8h-5d)	9.00	Plasterers (8h-5d)	10.00	Dump Truck Drivers, 6 yards or less	7
Housemiths, Architectural Iron (Outside) (8h-5d)	10.00	Plasterers' Hodcarriers (8h-5d)	7.50	Truck Drivers of Concrete Mixer Trucks: 2 yards or less	6
Housemiths, Reinforced Concrete or Rodmen (8h-5d)	10.00	Plumbers (8h-5d)	11.00	3 yards	6
Iron Workers (Bridge and Structural) Including Engineers (8h-5d)	12.00	Roofers (8h-5d)	9.00	4 yards	7
		Roofers, All Others (8h-5d)	8.00	5 yards	7
		Sheet Metal Workers (8h-5d)	10.00	6 yards	8
		Sprinkler Fitters	10.00		

GENERAL WORKING CONDITIONS

- Eight hours shall constitute a day's work for all crafts except as otherwise noted.
- Plasterers' Hodcarriers, Bricklayers' Hodcarriers, Roofers' Laborers and Engineers, Portable and Hoisting, shall start 15 minutes before other workmen, both at morning and at noon.
- Five days, consisting of not more than eight hours a day, on Monday to Friday inclusive, shall constitute a week's work.
- Transportation costs in excess of twenty-five cents each way shall be paid by the contractor.
- Overtime shall be paid as follows: For the first four hours after the first eight hours, time and one-half. All time thereafter shall be paid

- double time, Saturdays (except Laborers), Sundays and holidays, from 12 midnight of the preceding day, shall be paid double time.
- On Saturday, Laborers shall be paid straight time for an eight-hour day.
- Where two shifts are worked in any twenty-four hours, shift time shall be straight time. Where three shifts are worked, eight hour's pay shall be paid for seven hours on the second and third shifts, allowing one-half hour for lunch.
- All work, except as noted in paragraph 9, shall be performed between the hours of 8 a.m. and 5 p.m.
- In emergencies, or where premises cannot be vacated until the close of business, men then

- reporting for work shall work at straight time. Any work performed on such jobs after a night shall be paid time and one-half up four hours of overtime and double time the after, provided, that if a new crew is employed on Saturdays, Sundays or holidays which not worked during the five preceding days such crew shall be paid time and one-half.
- Recognized holidays to be: New Year's Day, Decoration Day, Fourth of July, Labor Day, Admission Day, Thanksgiving Day, Christmas Day.
- Men ordered to report for work, for whom employment is provided, shall be entitled two hours' pay.

MODERNIZED PRODUCTS

Brief Notes on New Materials and Equipment in the Building Industry.

MONEL METAL

The International Nickel Company has issued an interesting booklet dealing with their Trade Mark, "Monel," and entitled #35 Monel-Food Service Equipment. A very nicely arranged and illustrated booklet. Send for a copy by clipping the coupon.

86. DATA BOOK

The 1938-1939 Data Book by Westinghouse Electric and Manufacturing Company is just out and is a very well arranged catalogue. It is bound and has a comprehensive index and contains data and illustrations on Westinghouse equipment.

92. "LESS WATER"

"Less Water Yet More Placeability" is the title of a brand new booklet issued by the Master Builders Company. It has excellent illustrations and is well arranged.

RUBBER GOODS

The Goodyear Tire and Rubber Company's new catalogue, which they call "Mechanical Rubber Goods," has just been received. It is extremely well gotten up and is most interesting. It covers the field of industrial rubber products.

87. METAL LATH

"Metal Lath News" is the title of a new booklet received from the Metal Lath Manufacturers Association. Contains news and data on metal lath which should be of interest to contractors and builders. Send for your copy.

93. AIR CONDITIONING

Carrier Corporation announces a new booklet and it has a very cryptic message in its first page "Air Conditioning Is Only As Old As Carrier." This should prove an interesting piece of reading. Clip the coupon for your copy.

ALL ABOUT HARDWOOD

E. L. Bruce Company are issuing a new always worth-while little booklet each month. Much interesting material goes into this small monthly magazine and it has many illustrations and pertinent facts. Send for your copy.

88. GARDEN LIGHTING

The Pacific Coast Electrical Bureau has issued a very delightful broadside dealing with the lighting of gardens and is given the title of "Dinner at Eight . . . In the Garden." Clip the coupon for your copy.

FREE FOR THE ASKING

Check items on coupon, paste on letter head or postal card, and mail to Architect and Engineer.

88-A. ELECTRIC FANS

Two very interesting brochures have just been issued by the Emerson Electric Company. Both deal with this company's electric fans and contain a great deal of practical information on this subject which is of importance these summer days.

88-A. HOME LIGHTING

The same Bureau also announce the issuance of a new "Light in the Home," worth while booklets containing interesting material on the all-important question of proper lighting.

Architect and Engineer
68 Post Street
San Francisco, Calif.

Please send me literature on the following items as checked below. This request places me under no obligation.

- | | |
|----------------------------------|-------------------------------|
| 80 <input type="checkbox"/> | 87 <input type="checkbox"/> |
| 81 <input type="checkbox"/> | 88 <input type="checkbox"/> |
| 82 <input type="checkbox"/> | 88-A <input type="checkbox"/> |
| 83-83 A <input type="checkbox"/> | 89 <input type="checkbox"/> |
| 84 <input type="checkbox"/> | 90 <input type="checkbox"/> |
| 85 <input type="checkbox"/> | 91 <input type="checkbox"/> |
| 86 <input type="checkbox"/> | 92 <input type="checkbox"/> |
| | 93 <input type="checkbox"/> |

MODERNIZATION CLINIC

The Celotex Corporation have announced the opening of a "Basement Modernization Clinic" in Chicago and have issued some data which is most interesting, demonstrating what can be done with basement space heretofore unused. Send for this enlightening data.

90. HEAT CONTROL

Marsh Tritrol Company have a new broadside illustrating their heating system and featuring a new control "Marsh Unitrol." Send for your copy—clip the coupon.

NEW BOOK ON TILE

The Krafttile Company announce the issuance of a new booklet on their new #9 "Master Krafttile" high-fired. This information should prove of value to those interested in ceramics and modern tile.

91. ARMCO SALES APPEAL

From the American Rolling Mill Co. comes a broadside entitled "How Armco helps you Sell." This appears to be a very interesting item and should be well worth while to secure. The coupon will bring you a copy.

My Name

Name of Company

Street

City State

ARCHITECTS AND THE U. S. HOUSING ACT

By NATHAN STRAUS

THE time has come when architects are deliberately casting off the robes of high priests of the art of decoration and are donning instead the workaday clothes of men engaged in the business of designing machines for living. The disappearance of the luxury market has caused the profession to awaken from its lethargy, rub its collective eyes, and look around for greener pastures. Lo and behold, the fertile fields of public housing have appeared over the horizon. Public housing promises to raise the standards of architecture and also public esteem for the architect. If it does not, there will be no public housing worthy of the name.

The new concept of public housing will demand of the architects a reversal of many of their own old concepts. Formerly, the residential architect planned for a single purpose. He translated the standard of living, the personal idiosyncrasies, the culture (or lack of culture) of a single family into a creation too often dominated by the habits and conditions of Spanish peasantry of the 15th century or Gallic noblemen of the 17th century. The architect began by planning on as large and spacious a scale as possible and then later cut down, the cut depending upon the depth of his client's pocketbook and due regard for ostentation rather than regard for comfort and convenience.

Now, if the architect is to attain the place in the public housing scheme of things which is rightfully his, he must learn to blueprint for thousands of human beings, with all his senses alert to these elementary requirements: health, comfort, convenience, economy, durability. He will learn, bound by such limitations, to plan small and complete and to expand if, and as, his allotment of funds permits. However, all the essentials for good and wholesome living will be embodied in his first attempts. Whatever is added will only augment those essential qualities.

The new housing program presents great possibility for a long delayed renaissance of architecture. The first architect in history was the man who planned the first cave-dwelling, the first home. The production of homes was the prime function of the architect in those earliest days of history and will be, in my belief, the prime function of the architect in the world of tomorrow. The architect has in recent years been preoccupied with design for appearance. The architect for the world of tomorrow must concentrate on the fundamental purpose of architectural design—to make a place for living.

One effect of the United States Housing Authority program is to create the demand for this new type of architect, concerned with basic human needs, familiar with social and economic trend, trained to translate his knowledge of these human needs into the best

that modern scientific knowledge of building makes it possible to produce. Out of this must appear quite logically a strong functional architecture, pleasing in design, satisfying to its creators, answering completely its purpose.

It is my belief that this oldest of professions, architecture, is the one that shows today the greatest promise as the newest of new and broadened opportunities in the years ahead.

A REAL CREDIT

(Journal of Commerce, Portland, Ore.)

While it is a generally accepted fact that architectural talent of the highest order is to be found right here in Oregon, the many beautiful designs by Portland architects in the July number of "The Architect and Engineer" establishes the fact more clearly than ever. This special number is a real credit to Portland and Oregon.

Representative of the best in architecture in and near Portland, the artistic views of fine homes and public buildings that abound in the attractive pages of the volume leave no doubt of the ability of our local craftsmen, architects and engineers.

Glenn Stanton, well known Portland architect, is guest editor of this particular edition and selected the material. The magazine is published in San Francisco. Fred W. Jones is editor and Mark Daniels, associate editor.

The splendid photography and artistic presentation of the various architectural studies combines to show them to their best advantage. All who contributed to the pages, including the designers of the buildings, the builders and contractors, as well as those responsible for the art work and selection of material incorporated in the pages, deserve credit.

NEW MANAGER

E. Earl Glass is the new manager of the Engineers and Architects Association of Southern California, with headquarters in Los Angeles.

Mr. Glass is a former director and president of the Association. He was at one time executive secretary and manager of the Southern California Chapter, A.G.C., and the Southern California Rock Products Association.

CONSTRUCTORS' CONVENTION

A convention of all members of the construction industry of Southern California is announced for November 18-19 at the Biltmore Hotel in Los Angeles, sponsored by the Building Contractors Association of Southern California. Speakers of national reputation are being sought for the meeting.

ARCHITECTS' FEES FOR FEDERAL WORK

A SCHEDULE of fees for architectural services on housing projects has been transmitted by the American Institute of Architects to Nathan Straus, Administrator of the United States Housing Authority, for one year's trial.

The fees, which include normal engineering and landscape architectural services, range from 5 per cent for a project costing \$100,000 to 2.5 per cent for a \$10,000,000 project. The committee authorized by the Institute to prepare the schedule consisted of Walter R. McCormack of Cleveland, Ohio, chairman of the Institute's Committee on Housing; Richmond H. Shreve of New York; C. C. Zantzing of Philadelphia; William Stanley Parker of Boston, and Frederick W. Garber of Cincinnati.

The committee, in response to a request by Mr. Straus, conferred with officials of national organizations representing civil and mechanical engineers, landscape architects, and city planners. Determined "with due regard to the interests of all the technical branches of the work and reasonable economy in the provision of their services to low rental housing projects," the fees are as follows:

\$5,000, or 5 per cent, for work costing \$100,000; \$10,000, or 5 per cent, for a \$200,000 project; \$47,500, or 4.75 per cent, for a \$1,000,000 project; \$86,000, or 4.3 per cent, for a \$2,000,000 project; \$114,000, or 3.8 per cent, for a \$3,000,000 project; \$136,000, or 3.4 per cent, for a \$4,000,000 project; \$155,000, or 3.1 per cent, for a \$5,000,000 project; \$174,000, or 2.9 per cent, for a \$6,000,000 project; \$192,500, or 2.75 per cent, for a \$7,000,000 project; \$212,000, or 2.65 per cent, for an \$8,000,000 project; \$229,500, or 2.55 per cent, for a \$9,000,000 project; and \$250,000, or 2.5 per cent, for a \$10,000,000 project.

For intermediate costs, the fee is to be interpolated. Where earthquakes or other special structural conditions exist, or where sub-soil conditions require special foundations or more than one basement is involved, the architect is to be paid the extra cost to him, in accordance with a prepared schedule of fees for structural and foundation engineering services.

"The most economical results will be secured where full responsibility therefor is placed upon the architect and where his technical decisions are permitted to control the results," declares a statement by the Institute. "The Institute believes that the success of the housing projects requires that the architects be employed for full services of design and supervision.

"The practice indulged in by both public and private groups of engaging an architect for the preparation of drawings and refusing to permit him to supervise the construction will ultimately seriously undermine the profession and the art it represents."

Decentralization of the program of the Federal Housing Authority, with no more delay in carrying on the work than in private practice, was assumed by the Institute's committee. Projects intended to be covered

by the table of fees are those undertaken by local Housing Authorities, under the terms of the Housing Act of 1937, as administered by the United States Housing Authority. In one year the schedule may be reconsidered, following the hearing of evidence from architects engaged in the various projects.

"The committee feels that the maximum number of architects to be engaged on any one project should not exceed three, and that this organization might be considered on the basis of a firm of three partners," it is explained. "The fees agreed upon set a premium on ability to organize. It is obvious that this is not only an advantage to the housing movement but to the architects as well.

"It is recommended that the fee be made a lump sum amount, composed of the total of the architectural, engineering, and landscape architects' fees, with the contract so written as to protect the architect from delays and changes beyond his control."

Pointing out that little data was found as to the cost of preparing drawings, the committee suggests that architects employed on housing projects make an accurate record of costs confidentially available to the Institute's Housing Committee, to be used as a basis for determining fair fees. The items included in the committee's breakdown of costs are as follows:

Total cost of construction, total fee for architect as stipulated in the original contract, extras allowed, total final fee.

Expenses of the architect—architectural and structural drafting; overhead, embracing rent, wages, blue prints, travel, supplies, and miscellaneous; structural, foundation, and mechanical engineering; landscape architecture; profit.

The committee warns that "there is much to be done by architects in all localities in making sure that the all-inclusive fee is secured and supervision included."

Following is the schedule of fees as approved by the Institute:

Cost of Work	Architects %	Architects Fee	Structural Eng. %	Structural Eng. Fee	Foundation Eng. %	Foundation Eng. Fee	Hear. Pl. & Elec. %	Hear. Pl. & Elec. Fee
\$ 50,000			6		7.5		5.5	2750
100,000	5	5000	5		6		5	5000
200,000	5	10000	4		5.5		4.75	9500
300,000			3.5		5		4.5	13500
400,000			3.25		4.5		4.25	17000
500,000			3		4		4	20000
1,000,000	4.75	47500	2.5		3.5		3	30000
2,000,000	4.3	86000	2		3		2.5	50000
3,000,000	3.8	114000	1.75		2.75		2	60000
4,000,000	3.4	136000	1.75		2.75			
5,000,000	3.1	155000						
6,000,000	2.9	174000						
7,000,000	2.75	192500						
8,000,000	2.65	212000						
9,000,000	2.55	229500						
10,000,000	2.5	250000						

NOTE: For intermediate costs, the appropriate fee will be interpolated. In each case the percentage is applied to the cost of the work on which the service is rendered. In the case of the special structural and foundation engineers' fees where there is duplication of units, the percentage fee may be charged against the cost of each different unit plus an additional charge for each repeat of each unit rather than applying the percentage to the total cost of the work involved. Also, where such engineering services are required some element of the architect's work may in some cases be eliminated and the extra charge may reasonably be less, in such cases, than the actual amount of the special engineers' fees. For these reasons the actual amount of the fee in each case has not been developed in the above table.

Approval of The Institute refers solely to the architects' fees and not to the engineers' fees, approval of which may be by their respective organizations.

BACKSTAGE IN EUROPE'S INDUSTRIES *

By F. T. LETCHFIELD

A SCIENTIFIC research laboratory reflects the psychology of the country in which it is found, thus it may be used to gauge national habits. The natural sciences are universal in their application, so by observing the speed and the rate at which engineers translate scientific discoveries into industrial practices, within a given country, one may learn much of the long term economic outlook for that country.

It is quite impossible for anyone traveling in Europe to return without a host of impressions all centering upon the marked differences in economic philosophies, social outlook and standards of living existing between America and those countries across the Atlantic. The definite feeling of kinship which grows as one revels in the historical riches of England accentuates the disappointment which comes with the realization that physically, in an engineering sense, England has hardly emerged from the Victorian Era. Wooden cars, funny looking automobiles and 19th century plumbing are but surface effects—looking deeper one concludes that England's backwardness is primarily due to the Englishman's religious regard for tradition, with its concomitant of complacent satisfaction with things as they are.

And so it was something of a shock to observe the very splendid abilities at the top and the definite mediocrity at the bottom of the industrial structure in England. Nor is it easy for the American to rationalize the great disparity between the standards of living for a considerable number in the upper social strata of England and the great masses at the bottom. The evidence of such a gulf made one question the widespread belief held here in America that England has solved her social and labor problems on a much more enlightened basis than have we. We found England a country which is dropping farther and farther behind the rest of the world in all these things we call modernization, but, on the other hand, one is convinced that London is still the financial and business center of the world. The thought occurred to me that, could England adopt more of America's industrial philosophy and if in our own country we might follow the English practice of basing our laws on proven experience rather than upon wishful thinking and theoretical experimentation, both countries might be better off.

France, like England has contributed greatly to the field of pure science. But the French scientist seems to be working in an intellectual vacuum. It is due primarily, I believe, to the Frenchman's conviction that Paris is the hub of the intellectual universe. One will find students from all over the world in French schools and colleges but will find few Frenchmen studying beyond the borders of France. Such intellectual inbreeding is a devitalizing influence tending to confine scientific progress to academic limits. The French are good mechanics and good engineers and individually do

much brilliant work but their collective genius is frustrated by a medieval industrial philosophy which still regards labor as a commodity to be purchased in the cheapest market which still refuses to replace obsolete equipment, which still regards the purchase of a labor-saving device as an unwarranted extravagance. All in all, one is forced to the conclusion that France has much more to learn from America than it has to teach us. One does regret, however, that those among us who believe that the high road to industrial greatness lies in the direction of legislative restrictions or coercion could not be compelled to visit France and observe at first-hand what happens to industry when it is placed in a legislative straitjacket.

Our first contact with the precise mental processes of the German engineers was when we crossed the border and noticed the smoother road bed and cleaner buildings. Herr Hitler has torn up the Versailles Treaty, has given back to Germany her army, her navy, her air force and—more than all else—has restored the Germans' belief in themselves and their pride in their country. He is determined that Germany is to be economically self-contained and so all are mobilized and coordinated on a program of "ersatz"—meaning substitute. The scientists, engineers and research laboratories are endeavoring to find some indigenous material or to produce some synthetic product as a substitute for something heretofore imported.

I left Germany with a feeling of pathos and tragedy for, on one hand, one sees in Germany evidence of splendid physical accomplishments but, on the other hand, one sees sixty-five million splendid people being led by a madman waving a sword at a mad world, attempting an impossible economy which is rapidly raising the cost of living, lowering the standards of living and generating social pressures which sooner or later will explode unless they are relieved or diverted by war. It is fear of this last which covers all Europe like a pall.

And so after the disappointments of England, the archaic and chaotic picture in France and the tragic atmosphere of Germany, it is perhaps not surprising that as we set sail for home the query kept running through my mind—"Why is it that America is pre-eminent among all nations?" There are some who believe that America's unique economic status is due to our vast natural resources. But if that were the answer, then Russia would excel us. If it were due to a large, intelligent population, then China would lead the world. If it were because of the so-called "Capitalistic System" then France would have living standards approaching our own. If it were solely because of a democratic form of government, then the masses in England would be far better off. If it were the result of engineering skill or scientific knowledge, then Ger-

*Abstract of an address before the American Society of Civil Engineers, San Francisco.

many would crowd us for first place as a producer and consumer of the world's goods. America's greatness springs primarily from three factors. First, the age-old struggle for freedom blossomed and flourished here; second, the qualities of self reliance, resourcefulness and courage required to conquer our physical frontiers, became dominant, national traits; third, the sovereignty of the individual, the quality of rights, without hereditary or arbitrary privileges and rights not vouchsafed to all—the absence of caste or tradition.

WHERE BUILDING DOLLAR GOES

Where does the building dollar go today and how does its value compare with the 1926 dollar? In the Chicago area, according to the Employers' Association, which has recently completed a study of the cost of typical, modest dwelling houses in frame and brick, the former to cost \$5000, the latter \$6000 in 1926, compared with the same houses built as of May 1, 1938.

They find that the increased cost today over 1926 is 7.57% for frame and 8.69% for brick. Material costs are 12.5% and 10.8% less today than in 1926, overhead slightly higher, the increase attributed to higher labor costs and increased taxation. Overhead is responsible for an increase of 9%, labor 49 to 47%, and taxation 42 to 44%.

While material prices at this time are below those of 1926 due to sharp competition owing to lack of business, it must be realized that material dealers assumed the extra burdens of taxation and wage increases in processing and distribution without adding these, or at least adding only a part of them to their sales cost. With more active times, material prices would naturally go up and these overhead charges added onto the cost that the consumer pays.

The labor situation is different. Wage scales are not a question of supply and demand but of collective bargaining, with little hope of reduction. The present tendency to shorten hours can mean only an increase of wages to compensate for the differential.

WASHINGTON MONUMENT SINKING

Professor Dimitri P. Krynine, research associate in soil mechanics at Yale University, has just made a

diagnosis of soil conditions under the Washington Monument and under Pisa's famous leaning tower. The professor made his report at a clinic at the Connecticut Academy of Arts and Sciences at New Haven. The Washington Monument, he says, is sinking and Pisa's tower is swaying. The former he considers safe though afflicted with a slight foot disorder. A layer of clay 10 to 40 feet thick far below the monument is compressing like a sponge and the monument is settling slowly.

At Pisa the results of his studies seem almost incredible. "During September 1934 the tower moved north; but at the end of that month turned around and moved south. In January the movement to the north started again and the tower also moved eastward."

FOREST PRODUCTS LABORATORY

As an aid in answering questions about wood utilization research work of the Forest Service, the U. S. Department of Agriculture has just published "The Forest Products Laboratory."

The Forest Products Laboratory is the oldest institution in the world devoted to timber and wood research. Its 28 years of investigations have improved timber harvesting methods and have aided economy in use and diversification of forest crops.

The publication describes the work of the world-famous laboratory in timber harvesting and in the conversion of trees into commercial products, in silvicultural relations, in the chemistry and composition of wood, and the products being obtained by new processes. Investigations have also been made in timber mechanics and in means of obtaining greater structural strength with wood, in seasoning wood and controlling its moisture content, and in treating wood for better protection and service. Wood pathology and pulp and paper making also have been studied. One result of chemical and mechanical treatments developed by the Laboratory was the vast growth of the kraft paper industry in the South which became possible when the problems of using pine with a high pitch content had been solved.

"Scientific research is the means that must be used to gain a more thorough knowledge of wood in its chemistry, growth and structure."



Specify
CONDITIONED AIR HEAT
with the **DELCO CONDITIONAIR**
Product of General Motors

• The Delco Conditionair automatically heats, humidifies, filters, circulates healthful air throughout the home. Many exclusive features that contribute to greater economy and durability. Models for oil or gas. Get all the facts.

ALADDIN HEATING CORPORATION
Delco-Frigidaire Dealer

2222 SAN PABLO AVENUE • OAKLAND



Entrance Detail, Central Tower, San Francisco
Albert F. Roller, Architect

Ornamental Bronze Grille

Executed by

Sartorius Company, Inc.

2530 - 18TH STREET

SAN FRANCISCO

Underhill 2888

"Goods of the Woods"

Dependable Building Materials

Lumber and Millwork
for
All Types of Construction



Wolmanized or Creosoted
Lumber and Timbers
is your protection against
Termites and Decay



E. K. WOOD LUMBER CO.

San Francisco

Los Angeles

Oakland

TILE LENDS COLOR TO KITCHEN

(Concluded from Page 4)

of glass blocks to ceiling-height and complementing the clear transfused light with the generous use of color in tile.

A Venetian blind for the ordinary window which is empanelled in the glass block area, provides outlook above the sink as well as controlled ventilation. Another feature of the kitchen is that toe-space is provided by a convenient recess around the entire room beneath both the built-in cabinet work and the installed equipment.

For the bathroom off the master bedroom, Kraftile attained an exact match in color to "Corallin," a glowing deep pink which is an exclusive shade of a well-known manufacturer of plumbing fixtures. Tiled in harmonious lighter pink to door-height, the walls present an attractive surface. The 6 x 9 set (straight joint, horizontal) gives lines which add a sense of breadth to the room. Flooring 6 x 6 tile of old rose, deeper in hue than that of wainscoting and walls, completes an effective color scheme. In this room, the tub, equipped with shower, is recessed and the bottom of the tub set lower than the level of the flooring. Faced with tile, the tub's frontal area blends pleasingly with walls, floor and fixtures.

Color of unusual but attractive contrast was used in the guest bathroom which is also tiled to door height in the modern manner with 6 x 9 Kraftile. Here two shades of "faun" in the wall area complement the flooring of 6 x 6 tiles of a solid but lively tone of blue.

OIL DATA FOR ARCHITECTS

The formation of a special information department for architects, engineers and builders has been announced by Oil Burner Institute.

This department will concentrate entirely on supplying information on oil burner installations and heating costs, to firms in these fields. A large volume of detailed data on the subject of heating costs has been prepared, and will be supplied to any architect, engineer or builder requiring the information.

In announcing the opening of this department, G. Harvey Porter, Managing Director of Oil Burner Institute, said: "It is hoped that the information we shall be able to supply to architects, engineers, and builders regarding oil burners and heating costs will simplify their tasks and assist in providing their clients with products of our industry affording the greatest economy and satisfaction. We sincerely hope that persons or firms in these fields contemplating or undertaking the specification of oil burners, whether for large or small buildings, will not hesitate to call upon us for any information that may be desired."

All requests for information of this nature should be addressed to Oil Burner Institute, 30 Rockefeller Plaza, New York, N.Y.

15 PER CENT REWARD FOR SAFE DRIVING

Nine out of ten insured automobile drivers will receive a reduction in rates under the Safe Driver Reward Plan which went into effect Tuesday, February 1 on the 40th anniversary of automobile liability insurance, William Leslie, general manager of the National Bureau of Casualty and Surety Underwriters, estimated.

Starting February 1 in 27 states and the District of Columbia, private passenger car liability policies written by 32 stock companies, members of the National Bureau, carry the provision that at the end of a year from the time a newly issued policy becomes effective, the holder will receive a money reward of 15 per cent of the premium, provided no loss has occurred under the policy.

"Simultaneously with the introduction of the plan, insurance rates are being revised to reflect the latest experience in each territory. In many territories rates will be lower than they have been in the past. In others they will be higher because of unfavorable experience. In some they will remain the same," said Mr. Leslie.

"Included in the new rates will be a factor of 4.8 per cent which is an additional charge upon the driver who has accidents that produce losses. The 15 per cent reward to the safe driver will not only offset this factor but will produce for him an actual net saving of approximately 11 per cent in insurance cost. On the basis of our past experience, 88 per cent of our insured drivers should earn this 15 per cent reward. Under the stimulation of this plan, this percentage may be increased, and the resultant improvement in general experience should permit the establishment of lower basic rates in future periodic rate revisions," Mr. Leslie added.

"We believe the new plan is the greatest single contribution ever made toward promoting individual interest in traffic safety," said Mr. Leslie. "It should operate as a constant and effective reminder to insured motorists that good driving now has a real pocketbook appeal. We hope that this appeal will have an important effect in reducing traffic accidents."

The plan went into effect in Arizona, Arkansas, California, Colorado, Connecticut, Delaware, Florida, Georgia, Idaho, Kentucky, Maine, Maryland, Michigan, Minnesota, Missouri, Montana, Nebraska, Nevada, New Jersey, North Dakota, Rhode Island, South Carolina, South Dakota, Tennessee, Utah, Vermont, Wyoming, the District of Columbia.

"It is significant that in these states it has been indicated that if the award were allowed in the form of a 15 per cent reduction in the premium of the renewal policy, rather than a return of 15 per cent of the premium already paid, there would be no question of the legality of the plan. Our objection to making such modification in the plan is that it would compel the automobile owner to continue his insurance in the same company year after year in order to obtain the benefit which he had earned by his good driving

ENGINEERED HARDWARE

FOR NEW SCHOOL CONSTRUCTION

DALMO SIMPLEX WINDOW FIXTURES

"THE NATION'S SCHOOLHOUSE WINDOW"

HAVE BEEN USED IN OVER 200 SCHOOLS IN CALIFORNIA IN THE PAST TWO YEARS

KRAMER FLUSH VALVES

SHEER SIMPLICITY OF CONSTRUCTION MAKES FOR POSITIVE PERFORMANCE AND LOW MAINTENANCE

MacDONALD 
HARDWARE MANUFACTURING CO.

YUkon 0123

963 Harrison St.

San Francisco

STANLEY

THE SYMBOL OF LEADERSHIP
IN DOOR HARDWARE FOR 90 YEARS

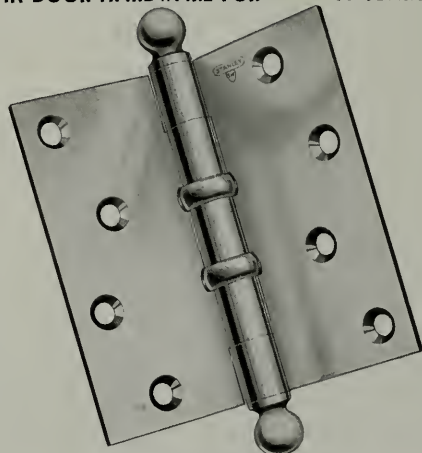

THE STANLEY WORKS
New Britain, Conn.

SAN FRANCISCO
576 Monadnock Bldg.

LOS ANGELES
407 American Bank Bldg.

SEATTLE
568 First Avenue, South

STANLEY

TRADE MARK

HARDWARE FOR CAREFREE DOORS

**Pressure
Treated Lumber?
Specify**

BAXCO C ZC

**"Chromated Zinc
Chloride"**

**Protects against decay
and termite attack**

•
*Available for prompt shipment
throughout California*

•
J. H. BAXTER & CO.

601 W. 5th Street
LOS ANGELES
Phone Michigan 6294

333 Montgomery Street
SAN FRANCISCO
Phone DOuglas 3883



INTERNATIONAL REVOLVING DOORS

were selected by ALBERT ROLLER, architect, for the main entrance to the new CENTRAL TOWER building.

Manufacturers of bronze, formica, stainless steel, aluminum, nickel silver and wood revolving and swing doors.

PACIFIC COAST REPRESENTATIVES

Frank Peck Specialty Co., Los Angeles, Calif.
Rolph Mills & Co., San Francisco, Calif.
D. E. Fryer & Co., Seattle, Wash.

MAIN OFFICE

**INTERNATIONAL
REVOLVING DOOR CO.**

EVANSVILLE, INDIANA

record. We feel that the assured is entitled to the reward, irrespective of whether he continues his insurance in the same or another company—in fact, we feel that he is entitled to it even if he should dispose of his automobile and not have any further need for the insurance."

The companies participating in the Safe Driver Reward Plan are: Aetna Casualty and Surety Company, Aetna Life Insurance Company, American Surety Company, Bankers Indemnity Insurance Company, Century Indemnity Company, Columbia Casualty Company, Eagle Indemnity Company, Fidelity and Casualty Company, Fireman's Fund Indemnity Company, Glens Falls Indemnity Company, Globe Indemnity Company, Great American Indemnity Company, Hartford Accident and Indemnity Company, London Guarantee and Accident Company, Ltd., London and Lancashire Indemnity Company, Maryland Casualty Company, Massachusetts Bonding and Insurance Company, New Amsterdam Casualty Company, New York Casualty Company, Norwich Union Indemnity Company, Occidental Indemnity Company, Ocean Accident and Guarantee Corporation, Ltd., Phoenix Indemnity Company, Royal Indemnity Company, Standard Accident Insurance Company, Standard Surety and Casualty Company, Sun Indemnity Company, Travelers' Indemnity Company, Travelers' Insurance Company, United States Casualty Company, United States Fidelity and Guaranty Company, Zurich General Accident and Liability Insurance Company, Ltd.

ETCHING SOLUTIONS AND PASTE

Glass frosting materials for application to every kind of glassware have been developed by the Westinghouse Electric & Manufacturing Company. These four materials are the results of many years of research for the exacting duties of frosting lamp bulbs.

A glass etch solution has been formulated which will produce permanent white markings on glass. Being very fluid, it can be applied with a rubber stamp. It will dry rapidly with a small amount of heat.

A metal etch solution is for application by rubber stamp to brass, copper and silver. It produces a permanent and pleasing black finish, drying rapidly in the air without heat.

Acid glass frosting solution is an etching material in paste form. It produces a fine grained white satin frost on any type of glass in 10 to 15 seconds. It is unique in the soft quality of the surface which it produces.

Normally designs are applied to glass by coating the surface with paraffin or lacquer and cleaning off the portion which is to be etched.

REJOINS PWA OFFICE

R. C. Stanley, member of Jones & Stanley, architects, Medical Arts Building, Seattle, returned early in July to his former post as engineer-inspector with the Public Works Administration. He is attached to the Washington division of the regional office, Failing Building, Portland.

BOOK REVIEWS

PAINTING AND DECORATING: By Dalzell and Sabin; American Technical Society; Drexel Ave. and 58th Street, Chicago. Price: \$1.50.

A thoroughly practical and interesting little book. Nicely illustrated, indexed and bound in a water-proof and vermin-proof binding. It is essentially modern in format and text and is a "How-to-do-it" book. This type of volume is very popular at the present time when home owners and others are doing so much of their own work.

BOOKKEEPING FOR PERSONAL AND BUSINESS USE: By Raymond V. Gradit; American Technical Society, Chicago. Price: \$2.50.

A really excellent volume and one which can afford the studious reader much pleasure and instruction in a phase of daily life in which most of us are more or less unfamiliar and at a loss to understand. This book is well arranged and gives details in setting up sets of books and the accurate methods of keeping careful and well balanced accounts. Should be of great value to any owner of a small business and to the average householder.

HIGH SPEED DIESEL ENGINES: By L. H. Thompson; American Technical Society, Chicago. Price: \$2.00.

A well written and practical handbook on Diesel engines. Such books as this one are within the range of the average buyer and are excellent for reference. Indexing is complete and diagrams are accurately rendered.

MACHINE SHOP OPERATIONS: By J. W. Barrett (formerly of Westinghouse Electric Co.); American Technical Society, Chicago.

A large book bound in flexible boards and containing industrial and technical data and general information. Especially valuable to shop foremen and superintendents. There is probably no question arising in machine shop operations or management that is not answered in this book which is indexed and well illustrated.

A HISTORY OF ARCHITECTURE—On The Comparative Method: By Sir Banister Fletcher, M. Arch.; F. S. A.; Charles Scribners Sons, New York City, N. Y. Price: \$12.00.

The Tenth Edition completely revised, enlarged and with some 4,000 illustrations. This is one of the most interesting of the historical treatises on architecture written by a scholar who has devoted time, thought and research to produce such a volume. Is worthy of a place in the library of any architect and could easily fill a space on the working shelf as a ready source of reference.

Equipped with Corrosiron Fan



Life Science Building, University of California, Berkeley

Federal, State and Municipal Architects Specify

—CORROSIRON—

fans, ducts, drain pipes and fittings because they are acid-resisting



Corrosiron Fan

Architects and Mechanical Engineers write for suggested specification form to

Pacific Foundry Co., Ltd.

New York

Los Angeles

3100 Nineteenth Street, San Francisco, Calif.

BUILD WELL

A PROPERLY designed and well constructed building is a credit to any city and a profitable investment for its owner.

Such structures are the STANDARD OIL BUILDING, MATSON BUILDING, FOUR-FIFTY SUTTER STREET, STOCK EXCHANGE, S. F. BASE BALL PARK, MILLS TOWER, OPERA HOUSE and VETERANS' MEMORIAL, San Francisco, OLYMPIC CLUB ALTERATIONS, SANTA ANITA RACING PLANT and other notable structures — all built or supervised by —

Lindgren & Swinerton, Inc.

Standard Oil Building
San Francisco

605 W. Tenth Street
Los Angeles

We Maintain a Termite Control Department

POMONA TILES

FOR

**Bathrooms and Kitchens
in over 60 colors**

Warehouses and Display Rooms

135 Tenth St. . . . San Francisco

629-33 North La Brea Ave. Los Angeles

6106 Roosevelt Way . . . Seattle

POMONA TILE MFG. CO.
PLANT — POMONA, CALIF.



Original ORIGINAL contours in the new Lightolier designs promote more interesting interiors as definitely as they provide greater lighting efficiency. Equipment of this type, formerly beyond the reach of the average home owner, is now available at exceptionally low prices. Write for the "Charm of a Well Lighted Home," our new interesting and helpful booklet.

INCANDESCENT SUPPLY CO.

SAN FRANCISCO : OAKLAND : FRESNO : LOS ANGELES

HARER GAS FURNACES HEAT

Consult us for the answer to your problems

HARER-PERRY COMPANY

5662 Keith Ave., Oakland, California

Phone HUmboldt 7928

**A Permanent Exposition
of the newest ideas
in home planning
and equipment.**



THE BUILDING MATERIAL EXHIBIT

Architects Bldg. • Fifth & Figueroa • Los Angeles • MU-6306

ARCHITECT IN PLYWOOD FIELD

Joseph Weston, architect of Los Angeles, and former Chief Architect of the National Resettlement Administration, has been appointed Southwestern representative of the Douglas Fir Plywood Association with headquarters in Los Angeles.

Mr. Weston is particularly well-equipped to take charge of Association activity in the Southwest since he is thoroughly familiar with the problems of architecture and construction in that area, having been a practicing architect in Los Angeles for many years. In addition, he has recently been engaged specifically in designing low-cost housing projects.

Mr. Weston studied architecture at the University of Pennsylvania, the New York Beaux Art Institute of Design and the Bellevue School of Arts in Paris, at which he enrolled following service as an aerial observer with the A. E. F. Following these studies he returned to Los Angeles and there practiced with his brother, Eugene Paton, President of the Southern California Chapter, A. I. A. During the 20's the firm of Weston and Weston for a time specialized in bank architecture and were responsible for designing many of the banks built in Los Angeles during that period.

Leaving his practice in 1923, Weston spent nine months in Mexico studying Mexican architecture and in 1925 he spent another year studying in France.

Intensive study of low-cost housing for suburban areas occupied most of Mr. Weston's time in the years following 1931 and as a result of his pioneering efforts in this field, he was asked to assist in the Resettlement Administration and Subsistence Homestead projects in California and Oregon in 1934. Later he was brought to Washington, D. C., as Chief Architect of the National Resettlement Administration and was responsible for the designing of many of the large projects which have been built in various parts of the United States.

Mr. Weston has prepared an article on Plywood for the September Architect and Engineer, which number is to feature this much talked about commodity in the building industry.

HIGH SCHOOL BUILDING

The Fall River Joint Union High School District has commissioned Messrs. Masten and Hurd, 442 Post Street, San Francisco, to prepare plans for a new school unit consisting of eight class rooms and a combination gymnasium and auditorium. Construction of this \$90,000 building will be wood frame and stucco, composition roof and maple floors.



IT'S NOT A HOME

(Commercial or Private)

WITHOUT

Beautiful Trees and Shrubs

MAKE THE

FACTORIES

WHOLESALE HOUSES

PRIVATE HOMES

Really look like

California

Largest selection of specimen plants
in California — from which to plan
your proper and liberal planting.

Roy F. Wilcox & Co.

WHOLESALE GROWERS

MONTEBELLO (Los Angeles County) CALIFORNIA



INCLUDE TREES IN YOUR PLANS

DAVEY, ORIGINATOR OF TREE SURGERY, OFFERS FREE
INSPECTION AND ESTIMATE.



SAN FRANCISCO Russ Bldg. SUtter 3377
Fresno Mattei Bldg.
LOS ANGELES Story Bldg. Tucker 1929
Local phones in: Pasadena, Palo Alto,
Oakland, San Rafael, San Mateo

SKILL - KNOWLEDGE - RESPONSIBILITY

USE BASALITE

Light-weight, pre-fabricated Con-
crete building products for floors,
walls, and roofs in your next
building.

BASALT ROCK COMPANY, INC.

Napa, California

STRUCTURAL STEEL

For Class A Buildings,
Bridges, etc.

JUDSON PACIFIC CO.

609 MISSION STREET
SAN FRANCISCO

Plants: San Francisco - Oakland

NOISE Control

Office Quieting
Sound-proof Partitions
Acoustical Correction

WESTERN ASBESTOS CO.

Building Materials *Mechanical Specialties*
SACRAMENTO OAKLAND
SAN FRANCISCO



No longer a problem
for the Architect

TRANSIT MIX CONCRETE AND MORTAR

makes delivery of material to the job swift and inexpensive . . . minimizing the architect's supervision costs and assuring his client a dependable mix.

Speed . . . Reliability . . . Economy
Let us co-operate with you

Golden Gate-Atlas Materials Co.

16th and Harrison Streets
San Francisco
Underhill 3650

THE BETTER PUBLIC LAVATORIES ARE EQUIPPED WITH CONVENIENT HAWS DRINKING FOUNTAINS



Model No. 2G

A combination water faucet and drinking fountain for lavatory installations in both public and private buildings. Not only a great convenience but saves cost of more expensive installations.

HAWS DRINKING FAUCET CO.

1808 Harmon Street

Berkeley

ARCHITECTS' SALES SERVICE

J. Z. Hollmann, general sales manager of The Celotex Corporation, has announced, supplementing the service and counsel rendered architects in the past, the establishment of a new department at general headquarters in Chicago, to improve architectural relations and make more readily available information in design, specifications or uses. This Architects' Sales Service Department will be managed by Ira L. Birner, who has been a member of the Celotex Company's architectural staff since 1924.

Under the direction of Mr. Birner, a special group of technically-trained men who are thoroughly familiar with present-day building design and construction methods will call on architects in all parts of the country, and will be available to assist in the solution of any problems involving all Celotex materials, or products. Their services for any special problem will be supplemented by research engineering and design staff, in the company's general offices.

STOP COMPLAINING

Can it be possible that American business men are losing the aggressiveness that once was theirs?

Nearly every newspaper or magazine today carries comments by some business leaders that industry is being stifled by government or some other reason is given for the troubles which beset us. Always, always, there is some excuse given for what ails us.

Maybe the government is too paternalistic. Maybe taxes are too high. Maybe the Wagner Labor Act is too severe. Maybe there are a hundred and one things that are all wrong—yet has it not always been so? Is there any time in history when the business man was not beset by numberless problems that seemed to defy solution—yet were solved.

Are the railroads any worse off now than they were during the early days when cutthroat competition was at its worst? Is the oil industry worse off now than years ago when as a youngster it went out and developed vast markets for its products? Are the banks with their swollen coffers

Donovan Automatic Awning Type Windows

Give 100% natural ventilation
and day-lighting control

UNIVERSAL WINDOW
COMPANY
Berkeley, California

"AMERICAN MARSH" Redi-Vac Vacuum Heating Pump

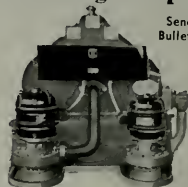

Send for
Bulletin 441

SIMONDS MACHINERY CO.
San Francisco 816 FOLSOM ST. Los Angeles 522 EAST 4TH ST.

SISALKRAFT

REG. U. S. PAT. OFF.

"More than a
building paper"

THE SISALKRAFT CO.

205 West Wacker Drive
(Canal Station) Chicago, Ill.
55 New Montgomery Street
San Francisco, Calif.

Pacific Manufacturing Company

High Class Interior Finish
Quality Millwork

454 Montgomery St. 6820 McKinley Ave.
San Francisco Los Angeles
GARfield 7755 THORnwall 4196

1315 Seventh Street, Oakland
GLEncourt 7850



CLIENTS will bless you for installing the Wesix "49'er" ELECTRIC BATHROOM HEATER. But try it first in your own home. Certain that you will like its forty-nine inches of INSTANT RADIANT HEAT and QUICK CIRCULATING HEAT, we are offering this smart new heater at factory cost to architects, for personal use! Limit one heater per architect. List price \$21.50. Please write on your regular letterhead, to: 1018 WESIX BLDG., SAN FRANCISCO

WESIX
WESIX ELECTRIC HEATER CO.



**HERRICK
IRON WORKS**
STRUCTURAL STEEL

18TH AND CAMPBELL STS.
OAKLAND, CALIF.
Phone GLencourt 1767

**FORDERER
CORNICER WORKS**

Manufacturers of

Hollow Metal Products
Interior Metal Trim
Elevator Fronts and Cabs
Metal Plaster Accessories
Sanitary Metal Base
Metal Cabinets
Flat and Roll Metal Screens
Commercial Refrigerators

269 POTRERO AVE.
San Francisco, Calif.
HEmlock 4100

worse off now than in the early financial history of this country when banking was a hazardous occupation? And so we might go on and on naming industries that have made great strides since their swaddling days.

Logic teaches us that things do not just happen—there is always a cause some place in the background. If our government today is too paternalistic, has not business helped to make it so? For these many years gone by has not business sought the aid of government to accomplish what business felt it could not do alone? Did not the railroads seek help through government land grants in the days of railroad building? Has not the merchant marine been dependent these many years on government subsidy?

Have not our manufacturers looked to the government to aid them through the protective tariff to meet foreign competition?

The government is bitterly denounced for its paternalistic policies today, yet in a recent issue of the staid "Los Angeles Times" appeared a cartoon that was reproachful of the Congress which adjourned last month without providing some solution to the railroad problem. Probably the Congress should not have left this problem dangling in the air—but why should the government be condemned because of its paternalistic policies and then reproached because it does not play the kind uncle to the suffering railroads?

Let us keep this in mind—the American people make their government—the government does not make the people. What we have today came about through our own volition.

We have a problem of unemployment today. At one time we had a problem of producing goods in mass quantities at low prices. Industry solved that. Why cannot industry tackle in the same way the problem of unemployment? American business men are, as a whole, highly intelligent and they had a reputation in the past of approaching their problems with a determination that augured success. Where is that spirit today? Are

How you can save

TIME

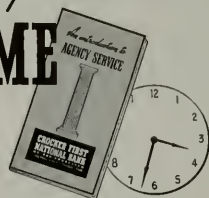

We can save the time you spend keeping records of transactions, collecting coupons, etc. . . . and perhaps save money, too, by helping to avoid losses due to mistakes and delays.

Our free booklet *An Introduction to Agency Service* tells how. Write or telephone for your copy.

Just ask for Booklet M-2

**CROCKER FIRST
NATIONAL BANK**
OF SAN FRANCISCO
California's Oldest National Bank

PAN-AMERICAN
(Simplex)



Model 12

AUTOMATIC OIL BURNER

The model illustrated is the smallest of many sizes and types of oil burners built by

**PAN-AMERICAN
ENGINEERING CO.**

820 Parker Street • Berkeley
Phone BErkeley 6755

Pitcher

**Improved
Disappearing Doors
Save 20% Space**

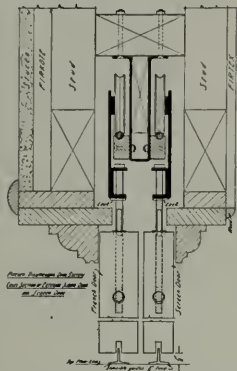

Joins with a 3 3/4" stud wall . . . steel studs
. . . adjustable steel and wood track.
Can be used for screen doors in connection
with French doors. Send for detail drawing.

E. C. Pitcher Co.
461 Market Street
San Francisco

Independent Iron Works

Structural Steel
Ornamental Iron
Steel Service Stations
Steel Tanks
Standard Steel Mill Buildings
Bridges

821 Pine Street Oakland

**Clinton
Construction Co.**
of California
*General
Contractors*

923 Folsom Street
San Francisco
SUtter 3440

American business men whipped?
Are they ready to quit?

The crying need today is for American business men to again adopt the courageous, resourceful attitude that they once had. Where help is really needed from the government, then let them seek it; but to sit on the doorstep and whine that the paternalism of government is killing us—to whine that this is wrong and that is wrong—will never be productive of corrective measures. We made our bed—now if we do not like it, let us get up and rearrange it to suit ourselves. It can be done—and present indications are that it will be done—but not by a lot of fellows that do nothing but spend their time yapping about the injustice being done them.

—California Plasterer.

SAN FRANCISCO FLATS

A two-story frame and stucco residence flat building has been designed by Messrs. Farr and Ward, 68 Post Street, San Francisco. The building will be situated on Greenwich Street, between Hyde and Leavenworth. Dr. Randolph G. Flood is the owner.

CENTRAL TOWER

Albert F. Roller, Architect

Terrazzo Work

by

CALIFORNIA TERRAZZO CO.

2085 SAN BRUNO AVE.
SAN FRANCISCO

EMPIRE
CONSTRUCTION
CO., Ltd.

BUILDERS

RUSS BUILDING
SAN FRANCISCO
SUtter 2989

COMFORT

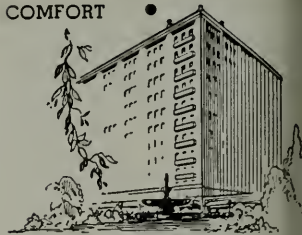

New **HOTEL
CLARK**
in Downtown
LOS ANGELES

Convenience is another offering of this hotel. Whether on business or pleasure bent, the Hotel Clark makes an ideal "base of operations," as well as a restful "billet" at the end of the day's "campaign." Good Food, naturally. And moderate charges, as well as for room accommodations, give final significance to assuring word — COMFORT

Single from \$2.50
Double from \$3.50

ROOMS
555
BATHS

Fifth and Hill

P. G. B. MORRIS, Manager

ANDERSON & RINGROSE

General Contractors

320 Market Street, San Francisco
Phone GARfield 2245

HIGH GRADE MILLWORK
AND INTERIOR FINISH
SASH AND DOORS

LANNOM BROS. MFG. CO.

FIFTH AND MAGNOLIA STREETS
OAKLAND, CALIFORNIA
Telephone: TEmplebar 3663

MULLEN MFG. COMPANY

BANK, STORE AND OFFICE
FIXTURES—CABINET WORK
OF GUARANTEED QUALITY
CHURCH SEATING

Office and Factory:
60-80 RAUSCH ST., Bet. 7th and 8th Sts.
San Francisco
Telephone UNDERhill 5815

G. P. W. JENSEN & SON

Building Construction

320 Market Street, San Francisco
Phone: GARfield 2444

DINWIDDIE CONSTRUCTION COMPANY

BUILDERS OF
GOOD BUILDINGS

CROCKER BUILDING
SAN FRANCISCO

Carl T. Doell Co.

Plumbing
Heating

Plumbing Contractor
Veterans Memorial Building
Oakland

467 21ST STREET
OAKLAND

Telephone GLencourt 8246

MORE HOUSE FOR YOUR MONEY

The nation-wide campaign to tell the story of "More House for Your Money" is spreading from coast to coast, according to Marshall Adams, managing director of The Producers' Council, the national organization of manufacturers of building materials and equipment, which is directing it.

"This campaign stresses," Mr. Adams said, "that you can get not only a better house, more pleasingly designed and better arranged, for your money, but it will be better equipped, more livable and will contain improved health and comfort features. At the same time, it will be cheaper to finance, require less up-keep and have innumerable 'plus value' not available just a few years ago.

"The modern house is actually a bargain. The loose way in which the subject of building costs has been treated, in many cases, has created an erroneous impression on many people and has done much to prevent recovery and the relief of unemployment. This movement was launched to give the correct interpretation of the subject."

"News comes from all over the country that communities are organizing to get this campaign under way," said Mr. Adams. "Builders, realtors, contractors, dealers, chambers of commerce and financial institutions are rallying to tell this true story of present day new home value to the public.

In 29 key cities where the Council has branch organizations known as Producers' Council Clubs, organization of the local industry in support of the program is already underway, Mr. Adams said. In other towns and cities, building materials and equipment dealers are taking the lead in forming groups to underwrite the campaign which will be financed locally in all cases.

"This campaign, the first of its kind in history will," predicted Mr. Adams, "not only stimulate home buying and home building, but it will demonstrate that the building industry is capable of organizing to discharge its responsibility to the public by giving it the facts about what it is providing for them."

ECONOMY OF SUB-STRUCTURE

That has to be
considered on
every job.

FERRO-PORCELAIN
needs but a
frame to hold it,
and it is
'quake' proof.

Inquiries promptly answered

FERRO ENAMELING CO.

1100 - 57th Ave., Oakland, Calif.

Smith

Lumber Company

WHOLESALE - JOBBING - RETAIL
FACTORY AND BUILDING LUMBER
PLYWOODS - ROOFING

DISTRIBUTING YARDS

San Francisco

Oakland

4th & Channel

19th Ave. &

Market 0103

Estuary

FRuitvale 3174

YOUR INQUIRIES SOLICITED

JOSEPH MUSTO SONS-KEENAN COMPANY

MARBLE
and
ONYX

535 NORTH POINT STREET
SAN FRANCISCO
1801 S. SOTO STREET
LOS ANGELES

ABBOT A. HANKS, INC.
Engineers & Chemists

INSPECTING — TESTING — CONSULTING
CONCRETE • STEEL • MATERIALS
CHEMICAL AND TESTING
LABORATORIES
• RESEARCH AND INVESTIGATION •

TESTS OF STRUCTURAL MATERIALS
DESIGN OF CONCRETE MIXES
SHOP AND ERECTION INSPECTION OF
STRUCTURES AND EQUIPMENT
INVESTIGATION OF STRUCTURES
AND MATERIALS
TESTS AND INVESTIGATION OF
FOUNDATION SOILS
FIRE RESISTANCE AND INSULATION
TESTS

624 Sacramento Street, San Francisco

Furring - Lathing
PLASTERING

CENTRAL TOWER

San Francisco

Albert F. Roller, Architect

**MARCONI
PLASTERING CO.**

211 MOULTON STREET
SAN FRANCISCO

ALAMEDA COUNTY COURT HOUSE
Oakland, California

Another Monument
to

DUNNE PRIMER SEALER
and
DUNNE SATIN WALL

The Best For

Looks - Protection - Economy

FRANK W. DUNNE CO.
41st and Linden Sts. Oakland, Calif.
MAKERS OF GOOD PAINT

VAUGHN - G. E. WITT Co.

Manufacturers and Distributors

Pump Governors	Oil Heaters
Safety Pump Governors	Relief Valves
Automatic Gas Regulating Valves	Oil Burner Governors
Gas Burning Equipment	Oil Burners
Vacuum Pump Governors	Oil Pumping Sets
Vacuum Regulating Valves	Oil Valves
Continuous Flow Steam Traps	Oil and Steam Strainers
Thermostats	Duplex Oil Pumps
Reducing Valves	Rotary Oil Pumps
	Boiler Feed Pumps
	Water Heaters
	Boiler Feed-Water Regulators

4224-28 Hollis St., Emeryville, Oakland

**THE
HERMANN SAFE CO.**

MANUFACTURERS AND DEALERS
OF

FIRE AND BURGLAR PROOF
SAFES AND VAULTS, SAFE-
DEPOSIT BOXES, ETC.

200 HOWARD STREET
SAN FRANCISCO
GARfield 3041 - 3042

**REPUBLIC STEEL
CORPORATION**



Manufacturers of

ENDURO Stainless Steel; TON-
CAN Copper Molybdenum Iron
Sheets and Pipe; and Steel Pipe,
Sheets and Reinforcing Bar for
every building purpose.

Write for information

Rialto Building, San Francisco, Calif.
Edison Building, Los Angeles, Calif.
White-Henry-Stuart Bldg., Seattle, Wash.

Phone GARfield 1164

Hunter & Hudson

Consulting Engineers

DESIGNERS OF HEATING
AIR CONDITIONING
VENTILATING AND WIRING
SYSTEMS, MECHANICAL
AND ELECTRICAL EQUIP-
MENT OF BUILDINGS

41 SUTTER STREET
ROOM 710

San Francisco California

Robert W. Hunt Company
ENGINEERS

Inspection - Tests - Consultation
Schools and Other Structures
Are Built as Designed

When Construction Materials are
Inspected at point of Manufacture
and during Erection by

ROBERT W. HUNT COMPANY

Cement, Concrete, Chemical, Metallurgical,
X-Ray and Physical Laboratories

Chicago - New York - Pittsburgh
Los Angeles - All Large Cities
San Francisco, 251 Kearny Street

**JOHN
CASSARETTO**

—Since 1886—And Still Active—

Building Materials

READY MIX CONCRETE
ROCK - SAND - GRAVEL - LIME
CEMENT - PLASTER - MORTAR
METAL LATH - WOOD LATH
STUCCO - WIRE NETTING

Service Unexcelled

Bunkers
Sixth and Channel, San Francisco
Phones: GARfield 3176, GARfield 3177

OVER NIGHT OR JUST A MEAL



SANTA MARIA INN

FRANK J. McCoy, Manager

SANTA MARIA, CALIFORNIA

On the Coast Highway, midway between
San Francisco and Los Angeles

**FINE WATER COLORS
AND PAPERS
FOR ARCHITECTURAL
RENDERINGS**

**H. S. CROCKER
COMPANY, Inc.**

720 MISSION STREET
MARKET STREET at SECOND
SAN FRANCISCO

**THE TORMEY
COMPANY**

GENERAL PAINTERS
AND DECORATORS

Phone UNDERhill 1913

563 FULTON STREET
San Francisco

ARCHITECTS' AND ENGINEERS' SPECIFICATION INDEX

Classified Directory of Building Material Manufacturers, Dealers and Contractors

*Denotes subscriber of ARCHITECTS' REPORTS, sponsored and endorsed by State Association of California Architects, and published daily by THE ARCHITECT AND ENGINEER.

ACOUSTICAL AND SOUND CONTROL

ARMSTRONG CORK PRODUCTS Co., 1355 Market Street, San Francisco.

*JOHNS-MANVILLE Sales Corp., 116 New Montgomery Street, San Francisco.

WESTERN ASBESTOS Co., 675 Townsend Street, San Francisco.

CRAMER Co., 50 Howard Street, San Francisco.

TURNER RESILIENT FLOORS, Inc., 141 New Montgomery Street, San Francisco.

CELOTEX Corp., 675 Townsend Street, San Francisco.

AIR CONDITIONING

S. T. JOHNSON Company, 940 Arlington, Oakland.

*ELECTRIC APPLIANCES, Inc., 2001 Van Ness Avenue, San Francisco.

ALADDIN HEATING Corporation, 2222 San Pablo Avenue, Oakland.

*FRANK EDWARDS Co. (General Electric), 930 Van Ness Avenue, San Francisco.

GENERAL Air Conditioning & Heating Company, 4001 Piedmont Avenue, Oakland.

ARCHITECTURAL METAL SUPPLIES

*BRAUN-STEEPLE Co., 636 Potrero Ave., San Francisco.

ARCHITECTURAL TERRA COTTA

N. CLARK & SONS, 116 Natoma Street, San Francisco.

GLADDING McBEAN & Co., 9th and Harrison Streets, San Francisco; 2901 Los Feliz Boulevard, Los Angeles; 1500 First Avenue South, Seattle; 79 S. E. Taylor Street, Portland; 22nd and Market Streets, Oakland; 1102 N. Monroe Street, Spokane; Vancouver, B.C.

KRAFTILE COMPANY, Niles, California, and 525 Market Street, San Francisco.

BATHROOM HEATERS

WESIX Electric Heater Company, 390 First Street, San Francisco; 631 San Julian Street, Los Angeles; 2008 Third Avenue, Seattle, Wash.

BLINDS—VENETIAN

GUNN-CARLE & Co., 20 Potrero Avenue, San Francisco.

*H. E. ROOT, 1865 California Street, San Francisco.

*RY-LOCK Co., 1355 Market Street, San Francisco.

BOILERS AND PIPE

*C. C. MOORE & Company, 450 Mission Street, San Francisco.

BRICK—FACE, COMMON, ETC.

N. CLARK & SONS, 116 Natoma Street, San Francisco.

GLADDING McBEAN & Co., 9th and Harrison Streets, San Francisco; 2901 Los Feliz Boulevard, Los Angeles; 1500 First Avenue South, Seattle; 79 S.E. Taylor Street, Portland; 22nd and Market Streets, Oakland; 1102 N. Monroe Street, Spokane; Vancouver, B.C.

BRASS

AMERICAN BRASS Co., Russ Building, San Francisco.

BUILDERS HARDWARE

THE STANLEY WORKS, New Britain, Conn.; Monadnock Bldg., San Francisco; Los Angeles and Seattle.

*SCHLAGE LOCK CO., 20 Blanken Avenue, San Francisco.

*FARMER'S UNION, 151 W. Santa Clara Street, San Jose.

*MAXWELL HARDWARE Company, 1320 Washington Street, Oakland.

*P. and F. CORBIN, New Britain, Conn.

BUILDING MATERIALS

BUILDING MATERIAL EXHIBIT, Architect's Building, Los Angeles.

*MELROSE BUILDING MATERIAL CO., 4501 Tidewater Avenue, Oakland.

*CONTRA COSTA BUILDING MATERIALS

Company, 2824 Shattuck Ave., Berkeley.

*MISSION BUILDING MATERIALS Co., Millbrae, Calif.

*RHODES & KENNEDY, 101 4th Street, Oakland.

BUILDING PAPERS

THE SISALKRAFT Company, 205 W. Wacker Drive, Chicago, Ill., and 55 New Montgomery Street, San Francisco.

BUILDING PRODUCTS

"BASALITE," a lightweight, pre-fabricated material for floors, walls and roofs—Basalt Rock Co., Inc., Napa, California.

CABINET WORK

*FINK and SCHINDLER, 552 Brannan Street, San Francisco.

MULLEN MANUFACTURING Co., 64 Rausch Street, San Francisco.

*MODERN FUTURE & Cabinet Co., 59 Oak Grove Street, San Francisco.

CEMENT

*CALAVERAS CEMENT Company, 315 Montgomery Street, San Francisco.

PORTLAND CEMENT Association 564 Market Street, San Francisco; 816 West Fifth Street, Los Angeles; 146 West Fifth Street, Portland; 518 Exchange Building, Seattle.

"GOLDEN GATE" and "OLD MISSION" manufactured by Pacific Portland Cement Co., 111 Sutter Street, San Francisco; Portland, Los Angeles and San Diego.

*HENRY COWELL Lime & Cement Company, 2 Market Street, San Francisco.

*SANTA CRUZ PORTLAND Cement Company, Crocker Building, San Francisco.

CEMENT—COLOR

"GOLDEN GATE TAN CEMENT" manufactured by Pacific Portland Cement Co., 111 Sutter Street, San Francisco; Portland, Los Angeles and San Diego.

CEMENT PAINT

FRANK W. DUNNE Company, 41st and Linden Streets, Oakland.

CHEMICAL ENGINEERS

ABBOT A. HANKS, Inc., 624 Sacramento Street, San Francisco.

ROBERT W. HUNT, 251 Kearny Street, San Francisco.

CLAY PRODUCTS

GLADDING McBEAN & Company, San Francisco, Los Angeles, Portland and Seattle.

N. CLARK & SON, San Francisco and Los Angeles.

KRAFTILE Company, Niles, California, and 525 Market St., San Francisco.

*GLADDING BROS. Mfg. Co., San Jose.

CLOCKS—ELECTRIC TIME

*INTERNATIONAL BUSINESS Machines Corp., 25 Battery Street, San Francisco.

CONCRETE AGGREGATES

GOLDEN GATE ATLAS Material Company, Sixteenth and Harrison Streets, San Francisco.

JOHN CASSARETTO, Sixth and Channel Streets, San Francisco.

*TRANSIT CONCRETE, Inc., 2500 Peralta Street, Oakland.

CONCRETE CURING & PROTECTION

THE SISALKRAFT Company, 205 W. Wacker Drive, Chicago, Ill., and 55 New Montgomery Street, San Francisco.

CONCRETE JOIST CONSTRUCTION

CONCRETE REINFORCING INSTITUTE (Steel Form Contracting Company), Harrison Street, San Francisco.

CONTRACTORS—GENERAL

LINDGREN & SWINERTON, Inc., Standard Oil Building, San Francisco.

DINWIDDIE CONSTRUCTION Co., Crocker Building, San Francisco.

CLINTON CONSTRUCTION Company, 923 Folsom Street, San Francisco.

ANDERSON & RINGROSE, 320 Market Street, San Francisco.

G. P. W. JENSEN, 320 Market Street, San Francisco.

*GEO. ARTHUR & SON, 941 So. Clarendon Street, San Mateo.

*A. T. BECKETT, 224 Scenic Avenue, Piedmont.

*L. M. G. PETERSON, 520 Bowdoin Street, Palo Alto.

*BARRETT & HILP, 918 Harrison Street, San Francisco.

DAMP-PROOFING & WATERPROOFING "GOLDEN GATE TAN PLASTIC Waterproof Cement," manufactured by Pacific Portland Cement Co., 111 Sutter Street, San Francisco; Portland, Los Angeles and San Diego.

DOOR HANGERS PITCHER'S SLIDING DOOR HANGERS, Sheldon Building, San Francisco.

DOORS—HOLLOW METAL FORDERER CORNICE Works, Potrero Avenue, San Francisco.

KAWNEER Mfg. Co., Eighth Street and Dwight Way, Berkeley.

ACID PROOF DRAIN PIPE CORROSION—Acid resisting pipe, fittings exhaust fans, pumps, etc., Pacific Foundry Co., 3100 19th Street, San Francisco; 1400 S. Alameda Street, Los Angeles.

DRINKING FOUNTAINS HAWS DRINKING FAUCET Co., 1808 Harmon Street, Berkeley.

ELECTRIC ADVICE PACIFIC COAST ELECTRICAL Bureau, 447 Sutter Street, San Francisco, and 601 W. Fifth Street, Los Angeles.

ELECTRIC FIXTURES *THE FRINK Corporation, 557 Market Street, San Francisco.

ELECTRICAL CONTRACTORS *ALTA ELECTRICAL and Mechanical Company 467 O'Farrell Street, San Francisco

ELECTRICAL EQUIPMENT—SUPPLIES *TRUMBULL ELECTRIC Mfg. Co., 260 Van Ness Avenue, San Francisco.

*GENERAL ELECTRIC Supply Corp., 1201 Bryant Street, San Francisco.

*NATIONAL ELECTRIC Products Co., 400 Potrero Avenue, San Francisco.

*WESTINGHOUSE ELECTRIC & Mfg. Co., 1 Montgomery Street, San Francisco.

ELEVATORS *WESTINGHOUSE ELECTRIC Elevator Company, 1 Montgomery Street, San Francisco.

*OTIS ELEVATOR Company, Beach Street, San Francisco.

ENAMELING—PORCELAIN FERRO ENAMELING Company, 1100 57th Street, Oakland.

FLOORING ASPHALT TILE, Western Asbestos Company, 675 Townsend Street, San Francisco.

*JOHNS-MANVILLE Sales Corp., 116 New Montgomery Street, San Francisco.

MAPLE FLOORING MANUFACTURERS ASSOCIATION, McCormick Building, Chicago, Ask your lumber dealer.

LE ROY OLSON COMPANY, 3070 - 17th Street, San Francisco.

*LILLY & CROWLEY, 123 Kansas Street, San Francisco.

FIXTURES—BANK, OFFICE, STORE MULLEN MANUFACTURING Co., 64 Rausch Street, San Francisco.

PACIFIC MANUFACTURING Company, 454 Montgomery Street, San Francisco, 1315 Seventh Street, Oakland, Los Angeles and Santa Clara.

ARCHITECTS' AND ENGINEERS' SPECIFICATION INDEX

Classified Directory of Building Material Manufacturers, Dealers and Contractors

*Denotes subscriber of ARCHITECTS' REPORTS, sponsored and endorsed by State Association of California Architects, and published daily by THE ARCHITECT AND ENGINEER.

FURNITURE

*ALLIED ART GUILD, Menlo Park.
*PENN. FURNITURE Shops, Inc., 130 Second Avenue, San Mateo.

GAS BURNERS

VAUGHN-G. E. WITT Company, 4224-28 Hollis Street, Emeryville, Oakland.

GLASS

W. P. FULLER & Co., 301 Mission Street, San Francisco. Branches and dealers throughout the West.
LIBBEY-OWENS-FORD GLASS Co., Toledo, Ohio; 633 Riello Building, San Francisco; 1212 Architect's Building, Los Angeles; 550 Skinner Building, Seattle.
PITTSBURGH PLATE GLASS Company, Grant Building, Pittsburgh, Pa. W. P. Fuller & Co., Pacific Coast Distributors.
*L. H. BUTCHER COMPANY, Fifteenth and Vermont Sts., San Francisco.
*EAST BAY GLASS Company, 621 Sixth Street, Oakland.
*COBBLEDICK-KIBBE GLASS Company, San Francisco, Oakland and San Jose.

HEATING—ELECTRIC

WESIX ELECTRIC Heater Company, 390 First Street, San Francisco; 631 San Julian Street, Los Angeles; 2008 Third Avenue, Seattle, Wash.

HEATING—GAS

*ALADDIN HEATING Corp., 22d and San Pablo Avenue, Oakland.
DAY and NIGHT WATER HEATER Company, Monrovia, California.
GENERAL Air Conditioning & Heating Company, 4001 Piedmont Avenue, Oakland.
HARER-PERRY Co., 5662 Keith Avenue, Oakland.
PACIFIC GAS & ELECTRIC Co., 245 Market Street, San Francisco.

HEATING—OIL

S. T. JOHNSON Company, 940 Arlington, Oakland.

HEAT GENERATORS

*WATROLO CORPORATION, LTD., 1170 Howard Street, San Francisco.

HEATING & VENTILATING EQUIPMENT

*AMERICAN RADIATOR Company, 4th and Townsend Streets, San Francisco.

HEAT REGULATION

JOHNSON SERVICE Company, Milwaukee, represented on the Pacific Coast by the following branch offices: 814 Riello Bldg., San Francisco; 153 West Avenue, 34, Los Angeles; 1312 N.W. Raleigh Street, Portland, and 473 Coleman Bldg., Seattle.

HOLLOW BUILDING TILE (Burned Clay)

N. CLARK & SONS, 116 Natoma Street, San Francisco.
GLADDING McBEAN & Co., 9th and Harrison Streets, San Francisco; 2901 Los Feliz Boulevard, Los Angeles; 1500 First Avenue South, Seattle; 79 S.E. Taylor Street, Portland; 22nd and Market Street, Oakland; 1102 N. Monroe Street, Spokane; Vancouver, B.C.

KRAFTILE Company, Niles, California, and 525 Market Street, San Francisco.

HOTEL AND RESTAURANT EQUIPMENT

*DOHRMANN HOTEL SUPPLY Company, 973 Mission Street, San Francisco.

INSPECTION AND TESTS

ABBOT A. HANKS, Inc., 624 Sacramento Street, San Francisco.
ROBERT W. HUNT Co., 251 Kearny Street, San Francisco.

INSULATION

CELOTEX Corp., 675 Townsend Street, San Francisco.
*JOHNS-MANVILLE Sales Corp., 116 New Montgomery Street, San Francisco.
WESTERN ASBESTOS Co., 675 Townsend Street, San Francisco.
CABOT'S QUILT—Gunn, Carle & Co., 20 Potrero Avenue, San Francisco.
VAPOREAL, Mfg. by Celotex Corp., 919 N. Michigan Avenue, Chicago.
FIRTEX of Northern California, 461 Market Street, San Francisco.
*GEORGE D. KARSCH, Builders Exchange, Sacramento, California.

INSURANCE

*FIREMAN'S FUND Insurance Company, 401 California Street, San Francisco.

INTERIOR DECORATORS

*REED DRAPERY SERVICE, 440 Post Street, San Francisco.
*M. H. WALES, 1933 Laguna Street, San Francisco.
*BETTY KENDALL, 251 Post Street, San Francisco.

KITCHEN EQUIPMENT

*MANGRUM, HOLBROOK & ELKUS, 301 Golden Gate Avenue, San Francisco.
DOHRMANN HOTEL SUPPLY CO., 972 Mission Street, San Francisco.

LACQUERS

W. P. FULLER & Co., 301 Mission Street, San Francisco. Branches and dealers throughout the West.

LIGHTING FIXTURES

*W. W. WARREN Company, 955 Mission Street, San Francisco.
*INCANDESCENT SUPPLY Company, 726 Mission Street, San Francisco.
*PHOENIX-DAY Company, 729 Mission Street, San Francisco.

LIMESTONE

*INDIANA LIMESTONE Company, 130 Lundo Way, San Francisco.

LINOLEUM, CARPETS, Etc.

*WEST COAST LINOLEUM & CARPET Co., 1163 Market Street.
*VAN FLEET-FREAR Company, 557 Howard Street, San Francisco.
TURNER RESILIENT FLOORS, Inc., 141 New Montgomery Street, San Francisco.
*D. N. & E. WALTER & Company, 562 Mission Street, San Francisco.
*CONGOLEUM-NAIRN, Inc., 1355 Market Street, San Francisco.

LOCKERS—METAL

*TRASK & SQUIER, 39 Natoma Street, San Francisco.

LUMBER

PACIFIC MFG. Co., 454 Montgomery Street, San Francisco; 1315 Seventh Street, Oakland; Los Angeles and Santa Clara.
SMITH LUMBER Company, Nineteenth Avenue and Estuary, Oakland.
MELROSE LUMBER & SUPPLY Co., Forty-sixth Avenue and E. Twelfth Street, Oakland.
E. K. WOOD LUMBER Company, 4701 Santa Fe Avenue, Los Angeles; 1 Drumm Street, San Francisco; Frederick and King Streets, Oakland.
*SANTA FE LUMBER Company, 16 California Street, San Francisco.
*FRIEND & TERRY LUMBER Co., Front & S Streets, Sacramento.
*OAKLAND LUMBER Co., 6901 E. 14th Street, Oakland.

MACHINERY—PUMPS, Etc.

SIMONDS MACHINERY Company, 816 Folsom Street, San Francisco.

MARBLE

JOSEPH MUSTO SONS-KEENAN Co., 535 N. Point Street, San Francisco.

MILLWORK

E. K. WOOD LUMBER Company, No. 1 Drumm Street, San Francisco, Oakland Los Angeles.
LANNON BROS. Mfg. Co., Fifth and Mag-nolle Streets, Oakland.
MELROSE LUMBER & SUPPLY Company, Forty-sixth Avenue and E. Twelfth Street, Oakland.
PACIFIC MFG. Co., 454 Montgomery Street, San Francisco; 1315 Seventh Street, Oakland; Los Angeles and Santa Clara.
SMITH LUMBER Company, Nineteenth Avenue and Estuary, Oakland.
*WESTERN DOOR and SASH Company, 5th and Cypress Streets, Oakland.
*OAKLAND PLANING MILL, 105 Washington Street, Oakland.
*T. P. HOGAN Company, 2d and Alice Streets, Oakland; 630 Mission Street, San Francisco.
*SAN MATEO PLANING MILL, San Mateo.

MONEL METAL

"INCO" BRAND, distributed on the Pacific Coast by the Pacific Metals Company 3100-19th Street, San Francisco, and 1400 So. Alameda Street, Los Angeles.
*WHITEHEAD METAL APPLIANCE CO., 4238 Broadway, Oakland.

NURSERY STOCK

*C. J. BURR, 305 Lytton Avenue, Palo Alto.
*CALIFORNIA NURSERIES, Niles.

OIL BURNERS

*SAN MATEO FEED and FUEL Company, San Mateo, Cal.
S. T. JOHNSON Co., 585 Potrero Avenue, San Francisco; 940 Arlington Street, Oakland; 1729 Front Street, Sacramento, and 1020 El Camino Real, San Carlos, Calif.
VAUGHN-G. E. WITT Co., 4224-28 Hollis Street, Emeryville, Oakland.
*HORABIN OIL & BURNER Company, 234 Hamilton Avenue, Palo Alto.
PAN-AMERICAN SIMPLEX OIL BURNER, 820 Parker Street, Berkeley.

ONIX

JOSEPH MUSTO SONS-KEENAN Co., 535 No. Point Street, San Francisco.

ORNAMENTAL IRON

INDEPENDENT IRON WORKS, 821 Pine Street, Oakland.

PAINTING, DECORATING, Etc.

THE TORMEY Co., 563 Fulton Street, San Francisco.
*RAPHAEL Company, 270 Tehama Street, San Francisco.

PAINTS, OIL, LEAD

W. P. FULLER & Co., 301 Mission Street, San Francisco. Branches and dealers throughout the West.
FRANK W. DUNNE Co., 41st and Linden Streets, Oakland.

NATIONAL LEAD Company, 2240-24th Street, San Francisco. Branch dealers in principal Coast cities.

*SHERWIN-WILLIAMS Company, 14 S Sherwin Avenue, Oakland.
*WALTER N. BOYSEN PAINT CO., 42nd and Linden Street, Oakland

PARTITIONS—MOVABLE OFFICE

PACIFIC MFG. Co., 454 Montgomery Street, San Francisco; 1315 Seventh Street, Oakland; factory at Santa Clara.

PLASTER

"EMPIRE" and "RENO HARDWALL PLASTER," manufactured by Pacific Portland Cement Co., 111 Sutter Street, San Francisco; Portland, Los Angeles and San Diego.

ARCHITECTS' AND ENGINEERS' SPECIFICATION INDEX

Classified Directory of Building Material Manufacturers, Dealers and Contractors

*Denotes subscriber of ARCHITECTS' REPORTS, sponsored and endorsed by State Association of California Architects, and published daily by THE ARCHITECT AND ENGINEER.

PLASTERING CONTRACTOR

JAMES F. SMITH, 271 Minna Street, San Francisco.

PLASTER—ACOUSTICAL

ALACOUSTIC, Sound Absorbing Plaster, manufactured by Pacific Portland Cement Co., 111 Sutter Street, San Francisco, Los Angeles and San Diego.

PLASTER MATERIALS

U. S. GYPSUM Company, Architect's Building, Los Angeles.

PLATE GLASS

IBBEY-OWENS-FORD GLASS Co., Toledo, Ohio; 633 Rialto Building, San Francisco; 1212 Architect's Building, Los Angeles; Mr. C. W. Holland, P.O. Box 3142, Seattle.

PLUMBING CONTRACTORS

CARL T. DOELL, 467-21st Street, Oakland. SCOTT Company, 243 Minna Street, San Francisco.

W. H. PICARD, 4166 Broadway, Oakland.

PLUMBING FIXTURES AND SUPPLIES

CRANE Co., all principal Coast cities.

STANDARD SANITARY Manufacturing Company, 278 Post Street, San Francisco.

WALWORTH CALIFORNIA Company, 665 Sixth Street, San Francisco.

W. R. AMES Co., 150 Hooper Street, San Francisco.

AY-HOLBROOK, Inc., 165 Eighth Street, San Francisco.

PRESSURE REGULATORS

AUGHN-G. E. WITT Co., 4224-28 Hollis Street, Emeryville, Oakland.

PUMPS

DIMONDS MACHINERY Company, 816 Folsom Street, San Francisco.

REFRIGERATION

DELCO-FRIGIDAIRE ELECTRIC REFRIGERATORS, Aladdin Heating Corp., 22d and Broadway, Oakland.

ROOFING CONTRACTORS

MALLOTT & PETERSON, 2412 Harrison Street, San Francisco.

ROOFING INSULATION

JOHNS-MANVILLE Sales Corp., 116 New Montgomery Street, San Francisco.

ROOF MATERIALS

JOHNS-MANVILLE Sales Corp., 116 New Montgomery Street, San Francisco.

PIONEER FLINTKOTE Company, Shell Building, San Francisco.

PARAFFINE Company, Inc., 475 Brannan Street, San Francisco.

GLADDING McBEAN & Co., 9th and Harrison Streets, San Francisco; 2901 Los Feliz Boulevard, Los Angeles; 1500 First Avenue South, Seattle; 79 S.E. Taylor Street, Portland; 22nd and Market Street, Oakland; 1102 N. Monroe Street, Spokane; Vancouver, B.C.

MARSHALL SHINGLE Company, 608-16th Street, Oakland.

N. CLARK & SONS, 112-116 Natoma Street, San Francisco; works, West Alameda.

*CERTAIN-TEED PRODUCTS Co., 315 Montgomery Street, San Francisco.

SAFES

HERRING-HALL-MARVIN SAFE Co., 214 California Street, San Francisco.

SAND, ROCK AND GRAVEL

JOHN CASSARETTO, Sixth and Channel Streets, San Francisco.

BASALT ROCK Co., Napa.

*KAISER PAVING Company, Latham Square Building, Oakland.

MELROSE BUILDING MATERIAL Co., 4501 Tidewater Avenue, Oakland.

SEATING

*HEYWOOD-WAKEFIELD Co., 180 New Montgomery Street, San Francisco.

*GENERAL SEATING Company, 160 Second Street, San Francisco.

SHADE CLOTH

CALIFORNIA SHADE CLOTH Co., 210 Bayshore Boulevard, San Francisco.

SHINGLE STAINS

CABOT'S CREOSOTE STAINS, Gunn-Carle & Co., 20 Potrero Ave., San Francisco.

AUTO SPRINKLERS

GLOBE AUTOMATIC SPRINKLER Co., 665-6th Street, San Francisco.

STANDARD STEEL BUILDINGS

INDEPENDENT IRON WORKS, 821 Pine Street, Oakland.

STEEL FURNITURE

*GENERAL FIREPROOFING Company, 160 Second Street, San Francisco.

STEEL—REINFORCING

*SOULE STEEL Company, Army Street, San Francisco and Los Angeles.

GUNN-CARLE Company, Portrero Avenue, San Francisco.

CECO STEEL PRODUCTS Co., 1280 Indiana Street, San Francisco.

*W. C. HAUCK & Co., 280 San Bruno Avenue, San Francisco.

*TRUSCON STEEL Company, 604 Mission Street, San Francisco.

STEEL—STAINLESS

REPUBLIC STEEL Corporation, Rialto Building, San Francisco; Edison Building, Los Angeles; White-Henry-Stuart Building, Seattle.

STEEL—STRUCTURAL

INDEPENDENT IRON WORKS, 821 Pine Street, Oakland.

JUDSON PACIFIC Company, C. F. Weber Building, Mission and Second Streets; San Francisco shops, San Francisco and Oakland.

HERRICK IRON WORKS, 18th and Campbell Streets, Oakland.

*MOORE DRYDOCK Company, Foot of Adeline Street, Oakland.

*WESTERN IRON WORKS, 141 Beale Street, San Francisco.

COLUMBIA STEEL Company, Russ Building, San Francisco.

STORE FIXTURES

MULLEN MFG. Co., 60 Rausch Street, San Francisco.

STORE FRONTS,

ZORI STORE FRONTS, Niles, Michigan.

KAWNEER MFG. Co., Eighth Street and Dwight Way, Berkeley.

STUCCO NETTING—WELDED

"WELDWEAVE" E. H. EDWARDS CO., 200 Bush Street, San Francisco; 620 E. 61st Street, Los Angeles; 1252 6th Avenue S., Seattle; 2690 N.W. Nicolai Street, Portland.

TEMPERATURE REGULATION

JOHNSON SERVICE Company, Milwaukee, represented on the Pacific Coast by the following branch offices: 814 Rialto Building, San Francisco; 153 West Avenue, 34, Los Angeles; 1312 N.W. Raleigh Street, Portland, and 473 Coloman Building, Seattle.

TELEPHONES—INTERCOMMUNICATING

*PACIFIC TELEPHONE and TELEGRAPH Company, 140 New Montgomery Street, San Francisco.

TERMITE CONTROL—WOOD PRESERVATIVE

E. K. WOOD LUMBER Company, No. 1 Drumm Street, San Francisco; 4701 Santa Fe Avenue, Los Angeles; Frederick and King Streets, Oakland.

J. H. BAXTER & COMPANY, 333 Montgomery Street, San Francisco.

TILE—DECORATIVE, Etc.

*CAMBRIDGE TILE Mfg. Co., 1155 Harrison Street, San Francisco.

POMONA TILE MFG. Co., plant, Pomona, Cal.; Sales Rooms, 135 Tenth Street, San Francisco; 217 S. La Brea Avenue, Los Angeles; 6106 Roosevelt Way, Seattle.

GLADDING McBEAN & Co., 9th and Harrison Streets, San Francisco; 2901 Los Feliz Boulevard, Los Angeles.

KRAFTILE Company, Niles California, and 525 Market St., San Francisco.

*CALIFORNIA ART TILE Corp., Richmond, Cal.

TREE SURGERY

DAVEY TREE SURGERY Co., Ltd., Russ Building, San Francisco; Story Building, Los Angeles.

TRUSSES

*SUMMERBELL TRUSS Company, 405 Builders Exchange Building, Oakland.

*ARCH-RIB TRUSS Company, 608 Sixteenth Street, Oakland.

VALVES

"KRAMER" Flush Valves, MacDonald Hardware Manufacturing Co., 963 Harrison Street, San Francisco.

SLOAN VALVE Company, Chicago, Ill.

SHAND AND JURS Co., Eighth and Carlton Streets, Berkeley.

VARNISHES

NATIONAL LEAD Company, 2240-24th Street, San Francisco. Branches and dealers in all principal Coast cities.

W. P. FULLER Company, San Francisco and principal Coast cities.

FRANK W. DUNNE Co., 41st and Linden Streets, Oakland.

VAULTS AND SAFES

HERMANN SAFE Company, 200 Howard Street, San Francisco.

*THE B. F. STURTEVANT Company, 759 Monadnock Building, San Francisco.

VENTILATING EQUIPMENT

WALL BOARD

*WESTERN BUILDERS SUPPLY Company, 401 Fourth Street, San Francisco.

WATER HEATERS—GAS AND ELECTRIC DAY AND NIGHT WATER HEATER Company, Monrovia, California.

*WATROLA Corporation, Ltd., 1170 Howard Street, San Francisco.

*PITTSBURGH WATER HEATER Co., 898 Van Ness Avenue, San Francisco.

*RUUD HEATER Company, 437 Sutter Street, San Francisco.

WESIX ELECTRIC HEATER Company, 380 First Street, San Francisco.

WINDOW SASH AND FIXTURES

"DALMO," SIMPLEX and "HAUSER" Casement Windows, MacDonald Hardware Mfg. Co., 963 Harrison Street, San Francisco.

*DETROIT STEEL PRODUCTS Co., 111 Sutter Street, San Francisco.

KAWNEER MFG. Company, Dwight Way and Eighth Street, Berkeley.

UNIVERSAL WINDOW COMPANY, [Donovan] 950 Parker Street, Berkeley.

WINDOW SHADES

AEROSHADE Company, represented by W. R. Knight, 557 Market Street, San Francisco.

CALIFORNIA SHADE CLOTH Co., 210 Bayshore Boulevard, San Francisco.

INDEX TO ADVERTISEMENTS

*Indicates Alternate Months

A		K	
ANDERSON & Ringrose	74	KAWNEER Company	3
ARCHITECTS Building	70	KRAFTILE Company	13
ANDERSON & Ringrose	74	L	
ARCHITECTS Building	70	LANNOM Bros. Manufacturing Company.....	74
B		LIBBEY, Owens, Ford Glass Company.....	*
BASALT Rock Company	71	LINDGREN & Swinerton, Inc.....	69
BAXTER & Company, J. H.	68	M	
BUILDING Material Exhibit	70	MacDONALD Hardware Manufacturing Company..	67
C		MAPLE Flooring Manufacturers Association.....	*
CALIFORNIA Terrazza Company.....	74	MARCONI Plastering Company.....	76
CASSARETTO, John	76	MULLEN Manufacturing Company.....	75
CELOTEX Corporation	*	MUSTO Sons Keenan Company, Joseph.....	75
CLARK, N., and Sons.....	*	N	
CLINTON Construction Company.....	74	NATIONAL Lead Company.....	12
CONCRETE Reinforcing Steel Institute.....	7	O	
CRANE Company	*	OREGON Brass Works.....	12
CROCKER First National Bank.....	73	P	
CROCKER, H. S.....	76	PACIFIC Coast Gas Association.....	9
D		PACIFIC Coast Electrical Bureau.....	11
DAVEY Tree Surgery Company.....	71	PACIFIC Foundry Company, Ltd.....	69
DAY and Night Water Heater Company.....	13	PACIFIC Manufacturing Company.....	72
DELCO-FRIGIDAIRE	65	PACIFIC Portland Cement Company.....	2nd Cover
DINWIDDIE Construction Company.....	75	PAN-AMERICAN Engineering Co.....	73
DOELL, Carl T., Company.....	75	PITCHER Company, E. C.....	74
DOUGLAS Fir Plywood Association.....	*	PITTSBURGH Plate Glass Company.....	*
DUNNE Company, Frank W.....	76	POMONA Tile	70
E		PORTLAND Cement Association.....	Back Cover
EMPIRE Construction Company.....	74	R	
F		REPUBLIC Steel Corporation	76
FERRO-PORCELAIN Building Company.....	75	S	
FORDERER Cornice Works.....	73	SANTA Maria Inn.....	76
FULLER Company, W. P.....	*	SARTORIUS Company	66
G		SIMONDS Machinery Company.....	72
GLADDING, McBean & Company.....	*	SISALKRAFT Company	72
GOLDEN Gate Atlas Materials Company.....	72	SLOAN Valve Co.....	*
GUNN, Carle & Company	8	SMITH Lumber Company.....	75
H		STANLEY Works	67
HANKS, Inc., Abbot A.....	76	T	
HARER-Perry Company	70	TORMEY Company, The.....	76
HAWS Drinking Faucet Company.....	72	U	
HERMANN Safe Company.....	76	UNIVERSAL Window Company.....	72
HERRICK Iron Works.....	73	V	
HOTEL CLARK	74	VAUGHAN-G. S. Witt Company.....	76
HUNT, Robert W. Company	76	W	
HUNTER and Hudson	76	WALKER, P. J. Company.....	11
I		WESIX Electric Heater Company.....	73
INCANDESCENT Supply Company.....	70	WILCOX, Roy F., Company	71
INDEPENDENT Iron Works.....	74	WOOD, E. K., Company.....	66
INTERNATIONAL Revolving Door Company.....	68	WESTERN Asbestos Company.....	71
J		Z	
JENSEN & Son, G. P. W.....	75	ZELINSKY, D., & Sons.....	12
JOHNSON, S. T., Company.....	13	ZOURI Store Fronts.....	3
JOHNSON Service Company	5		
JUDSON Pacific Company.....	71		

HE

ARCHITECT

ND

ENGINEER

"I SURE LIKE TO
WORK WITH THIS
NEW PLYSCORD
SHEATHING."

"ME TOO! AND
IT'S SPECIFIED FOR
ROOF, WALLS AND
SUB-FLOORS!"



Today Architects Everywhere Are Building
Better Homes, Saving Clients Money With

TRADE MARK
NEW PLYSCORD SHEATHING!

REG. U. S. PAT. OFF. PEND.

You can build warmer, more rigid, dust-proof homes with PLYSCORD — the new Douglas Fir Plywood trade-marked sheathing. It's *real lumber* — cross-laminated into strong, light panels — and mill-scored for easy nailing, with guide lines on 16-inch centers. For easy fit, PLYSCORD panels come in two widths, 32" and 48", each a full 96" long; three thicknesses, 5/16", 3/8" and 5/8".

You'll save on overall job time, often as much as 50% on comparable labor costs, and prevent unnecessary material waste when you specify PLYSCORD.

These savings have been laboratory tested — and proved on job after job. Yet with these savings PLYSCORD gives six times more rigidity than ordinary horizontal sheathing.

Specify PLYSCORD on your next sheathing job. And remember — there's an economical grade of Douglas Fir Plywood for all subfloor, partition, wall paneling and interior finishing jobs, as well as hot-pressed, resin-bonded grades for permanent exterior use. Douglas Fir Plywood is available through progressive lumber dealers everywhere.



Here's the famed guide line for easier, faster nailing — just one of Plyscord's many advantages.

- QUICK — EASY NAILING
- SAVES TIME — LABOR
- TWO WIDTHS
- TAKES FEWER NAILS
- IMPROVED FACE
- GIVES GREATER COMFORT

**DOUGLAS FIR
PLYWOOD**

Real Lumber
**MADE LARGER, LIGHTER
SPLIT-PROOF
STRONGER**

INFORMATION

Our well-equipped Technical Division offers co-operation in adapting Douglas Fir Plywood to special problems, and recommending the proper types and grades to produce the utmost serviceability and economy. Address DOUGLAS FIR PLYWOOD ASSOCIATION, Tacoma Building, Tacoma, Washington.

The **SEPTEMBER** 1938

ARCHITECT & ENGINEER

Fred W. Jones, Editor

Mark Daniels, A. I. A., Associate Editor

Edgar N. Kierulff, Assistant Editor

CONSULTING BOARD
OF EDITORS

Architectural—

Arthur Brown, Jr.
Frederick H. Meyer
Timothy L. Plueger
Will G. Corlett
Harry Michelsen
Lewis P. Hobart
David C. Allison
Gordon B. Kaufmann
Harris C. Allen
Glenn Stanton

Engineering—

H. J. Brunnier
L. H. Nishkian
William Adrian
Wm. H. Popert
Homer N. Hadley
John J. Gould
Geo. E. Atkins

Advertising Manager—

J. Leslie Meek

Architects' Reports—

Vernon S. Yallop

THE ARCHITECT AND ENGINEER, INC., 68 Post Street, San Francisco, EXbrook 7182. President, K. P. Kierulff; vice-president, Frederick W. Jones; secretary, L. B. Penhorwood. Los Angeles office, 832 W. Fifth Street. Published on the 12th on each month. Entered as second class matter, November 2, 1905, at the Postoffice at San Francisco, California, under the Act of March 3, 1897. Subscriptions, United States and Pan America, \$3.00 a year; Foreign countries, \$5.00 a year; single copy, \$.50.

Contents

FRONTISPIECE

COLUMBIA BROADCASTING STUDIO, HOLLYWOOD, CALIFORNIA

Wm. Lescaze, Architect; Earl Heitschmidt, Associate Architect

TEXT

PLYWOOD BECOMES AN INFLUENCE IN DESIGN	15
Joseph Weston, Architect	
FINISHING DOUGLAS FIR PLYWOOD	25
G. N. Arneson	
FROM SUMMER COTTAGE TO PERMANENT HOME	27
PLYWOOD IN ENGINEERING AND CONSTRUCTION	35
N. S. Perkins, C. E.	
UNIQUE OUT-OF-DOOR LABORATORY IN DOUGLAS FIR FOREST	39
CHINESE ARCHITECTURE AT THE EXPOSITION	41-49
Mark Daniels	

PLATES AND ILLUSTRATIONS

Columbia Broadcasting Studio, Hollywood	16
Philharmonic Auditorium, Los Angeles	17
House of Dr. B. A. G. Fuller, Hollywood	18
Ralph C. Flewellin, Architect	
Four Houses by Michael Goodman, Architect	19-24
Alterations to Summer Cottage Near Tacoma, Washington	27
Silas E. Nelson, Architect	
House of Earl Hoffman, Los Angeles	29-30
Leo F. Bachman, Architect	
Store Modernization	31
Gaston C. Lance, Architect	
Blue Ridge Model Home, Near Seattle	38
T. Francis Bellamy, Architect	
Pack Hall, Near Tacoma, Washington	39
Buildings For Chinatown, Golden Gate International Exposition	41
Mark Daniels, Architect	
Portfolio of Architectural Plates of Douglas Fir Plywood Paneling	45

RUNNING FIRE

by
MARK DANIELS, A.I.A.

Neo Art

At the Family Club outing the lawn was decorated with imitation stuary done in cut outs and painted effects. There was nothing about it that recalled Phidias, Colini or Putnam. In fact its sole merit was an intended laughter-provoking quality that threw a clear light on certain styles of modern art.

We were all trying to give it a new style name, largely based upon the utter absence of any signs of piberty, and had about decided that it should be called "I-Connick-elastic" when Tim Pflueger rushed up shouting "Our stuary has all been Connickized."

* * *

Passé

H. G. Wells started a mild rum-pus a few months ago when he said, in Washington, that the United States was out of date.

Criticism is a recognized form of teaching. At Beaux Arts it is the adopted method. Perhaps we in the United States could learn some things if we took more kindly to criticism.

Surely something can be learned from the example of traffic control in London and throughout all England. Are we not a little behind the times in our crime prevention and punishment? We have some reason on our side in forbidding smoking in the movie theaters. There are still some men who do not smoke. But in radio control the turning of the time over to the publicity hounds really does seem a little out of date.

* * *

Misnomer

Lee Cutler was awake late into the night. He was pondering the problem of selecting a committee that would do certain work at the Exposition and do it "now." The work was important and called for intelligence and action.

In the morning he said to his wife, "My dear, I have done a good night's work. I have fitted together

a personnel for that committee that takes a load of worry from my shoulders."

"Tell me who they are, Lee," his wife replied.

"Well," said Lee, "I have Florence McAuliffe, chairman. Then Charlie Purcell, Jim Smythe, Lloyd Dinkelspiel and Charlie Stanton. Some committee."

"That's not a committee," said Mrs. Cutler. "That's a gang."

* * *

Two Squibbs

From the Pen of Robert Wells Ritchie:

"A few nights before an Easter Sunday, when the rain was coming down like water over a spillway, a rookie cop discovered two gilded youths of society on their hands and knees—raincoats dragging in the slop—before the show window of the town's swankiest candy store. Their noses were pressed against the glass. They shifted from spot to spot with seal-like shufflings and strangled little cries of excitement. When the rookie inquired what-the-hell, the wholly beguiled youths invited him to join them in a swell game. They were looking through the peep-holes in the candy Easter eggs the other side of the glass at the perfectly swell scenes inside them.

The cop accepted their invitation."

THE SECOND

"San Francisco's first fling at the world's fair racket was with its Midwinter Exposition of 1894—a postlude to Chicago's Columbian show. At that time a one-gallus Oregon farm boy not long broken to shoes and carrying the high-falutin' name Homer Davenport was a sketch artist on young Willie Hearst's Examiner. Unmarked as yet by the shining finger of Genius—unmarked by anything but a half-quart of freckles. He carried a raw half-potato to his drawing board and gnawed it while he worked.

A day at the exposition was set aside for San Francisco's Chinese. In gratitude for their emancipation from the bitter hostility of a gen-

eration before, the On Leongs and the Fo' Bluddahs in Chinatown determined to evidence to San Francisco their appreciation of the boon of reinstatement in the general order of human beings. Hearst undertook cheerfully to applaud their efforts. He ordered Davenport out to do a seven-column page-one sketch of the Parade of the Great Dragon for next morning's paper. He sent his best word-smith along with the Oregon rutabaga juggler to do some columns of fancy writing to go under the sketch.

The roguish twain saw the parade all right, but as through a glass—several glasses in point of fact—darkly. For the writer had led the artist down some misty paths where the rye posies bloom and the Mamie Taylors sit behind their shuttered windows of sin. When it came time to go back to the Examiner, Davenport, surveying his rough sketch notes, saw with fluttering pulse he had lined in the many elaborate banners carried in the procession; but they were bare and devoid of ideographic inscription.

"Give it no thought," his companion soothed. "I know where you can copy lots of those chicken tracks." And he led Davenport to the vault in the Chinese building marked GENTS in two languages. Next morning's front page flaunted a colorful Oriental scene crackling with the budding genius of Homer Davenport.

Willie Hearst was jubilant. He was feeling an unwonted fillop of affection for his jayhawker sketch artist. . . . When the Chinese consul-general sent in his card.

"Excuse a natural curiosity, Mr. Hearst! but why you insulting Chinese people who are proud to honor your great city?"

"Insulting!—Insulting!"—in the Hearstian pipe of a startled mother tomtit. "Why, see this seven-column lay-out—this perfect reproduction in India ink of your—"

"Mr. Hearst does not read my language, perhaps."

"No."

"Then permit me to translate the Chinese writing appearing on these banners carried by the paraders."

Which the general did."

LASTING BEAUTY ★ DEPENDABLE SERVICE ★ LOW UPKEEP COST



-WITH RUSTLESS METAL

Entrances

BY **Kawneer**

A MOST significant recent development is the rapidly increasing use of Kawneer Rustless Metal Doors and Entrances in store fronts, commercial and public buildings, and residences. Kawneer Doors offer interesting possibilities for the designer. Attractive and beautiful, they harmonize with the rest of the building and make the entrance unusually inviting. Maintenance and upkeep costs are eliminated, since these sturdy doors require no painting or refitting—will not warp, swell, shrink or sag. They require practically no attention—offer years and years of dependable service. Furnished in aluminum, bronze, or other durable non-ferrous metals—in welded-tubular and flush types for buildings and store fronts; in tubular and casement types for residential work. Kawneer furnishes the complete entrance with doors, frame, transom, side lights and ornamental work as specified.

Standard Kawneer Welded Tubular Door in Alumilited Aluminum. Installed in Home Furniture Co. Store Front, Fort Dodge, Iowa.



Store front, New York.
Chas. Telchin & F.
Ginna, Architects.



Bank, Grand Rapids,
Mich. Knecht, McCarty
& Thebaud, Inc. Arch.



Residence in Kansas
City, Edward W. Tanner,
Architect.

Send for this complete new booklet on Kawneer Doors and Entrances. Write The Kawneer Company, BERKELEY

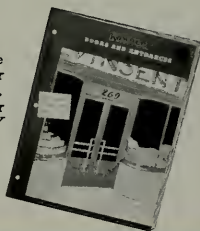

FOUNDED IN 1905 —
BY A PRACTICING ARCHITECT

Kawneer

Rustless Metal Store Fronts • Doors • Sealair Windows • Architectural Metal Work

For data see catalogs in SWEET'S; or write The Kawneer Company, at Niles, Michigan, New York, Chicago, or Berkeley, Calif.

Dealers in principal cities.

TRACTOR BUILDING OF SUPER-HARBORD



THIS building, treated along modern lines, is the new home of the Truck and Tractor Company, Inc., of Aberdeen, Washington. The architect, Clarence W. George, has made extensive use of Harbord throughout the building. The exterior covering is $\frac{3}{4}$ " Super-Harbord with edges shiplap rabbeted and outside edges eased to form a slight "V" joint, which show both vertically and horizontally. The cantilever beams supporting the portico are framed with dimension lumber and have $\frac{3}{4}$ " Super-Harbord nailed and glued into place to form stressed covering.

The interior of the building is completely lined with Harbord fir, with the exception of the executive office which is done in Super-Harbord Philippine mahogany. The truss framing of the roof has Harbord fish plates.

The large front doors were constructed on the job. Super-Harbord was used on both sides of the door frame, being nailed and glued into place. The doors have counter-balanced weight lifts and may be easily raised by one person.

A STREAMLINED PORTLAND SERVICE STATION



TYPICAL of the new trend in streamlined service stations is the Sunset station, Portland, by Clausen & Clausen, architects of Portland, Oregon. Completed at 120th and Stark Streets, it is the first unit of a number to be built for the Federal Distributing Company. The station is constructed completely of Resnprest, a waterproof all-weather plywood, widely used in boat building.

"We used resin-bonded plywood instead of metal," said J. A. Patterson, manager of the company, "because of a 50% saving in cost, and also because of its workability for rounded corners and cut-outs."

The station is designed for the best possible display of merchandise. It is finished in gleaming white with marine blue trimming in horizontal stripes that emphasize the streamlined effect. The interior finish is regular plywood. Eighth-inch Resnprest was used for the rounded corners and three-eighths inch was used for the remainder of the building.

The special waterproof and weatherproof plywood is a product of the M and M Woodworking Company, Portland, Oregon, and is processed on a hot plate press with pure phenol formaldehyde resin glue.

*The CORNER WINDOW is the keynote
of this modern home.*



Residence of Mr. and Mrs. Chalfant Head, Ojai, Cal.

More and more, architectural ingenuity is expressed in intriguing and expansive areas of glass. Larger windows... picture windows ...corner windows...lend a distinctive note to modern design—contribute a more pleasant, more cheerful atmosphere to the home.

With glass used more extensively than ever before, its quality becomes a matter of paramount importance. Libbey-Owens-Ford Quality Glass is today, as it has been for many years, Clearer, Brighter and Flatter than any that the industry has ever offered. Libbey-Owens-Ford Glass Company, Toledo, O.



LIBBEY · OWENS · FORD *QUALITY GLASS*

LOOK FOR THE LABEL

LOCK-TITE

SPEEDS UP EVERY JOB!

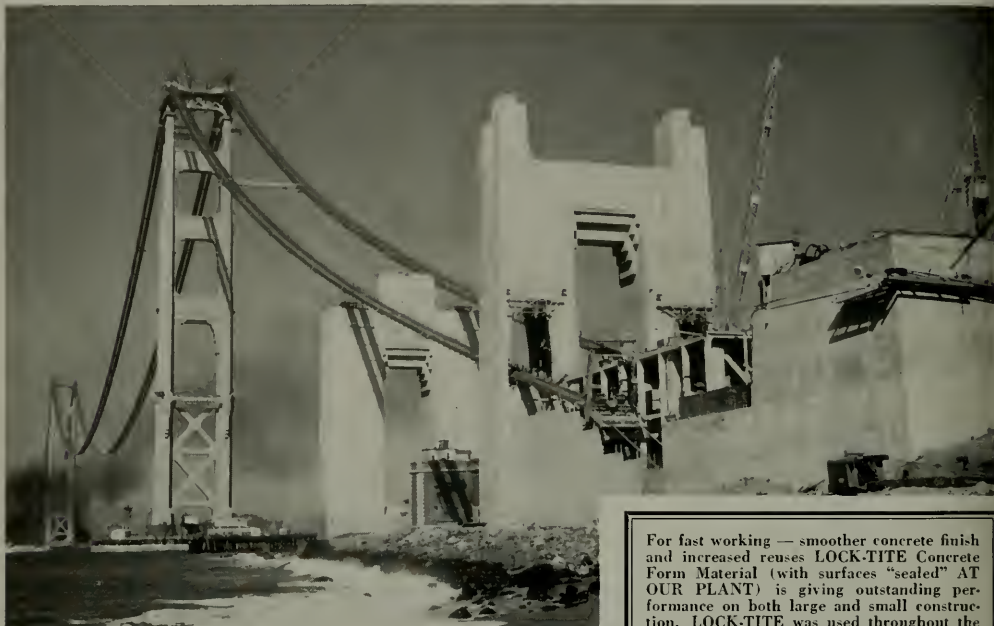

For fast working — smoother concrete finish and increased reuses LOCK-TITE Concrete Form Material (with surfaces "sealed" AT OUR PLANT) is giving outstanding performance on both large and small construction. LOCK-TITE was used throughout the entire San Francisco-Oakland Bay Bridge. Photo—Golden Gate Bridge, San Francisco —a perfect example of plywood concrete form construction.

Major Construction Projects Throughout the Nation . . . Have repeatedly proved the Advantages of Specifying

LOCK-TITE

DOUGLAS FIR

CONCRETE FORM · PLYWOOD PANELS

A thickness and finish for every structural need — each made to the same dependable O-W standard including:

- Special Waterproof Glue Bond "Hourly tested" • Tite Core Construction • Carefully Selected Veneers • Precision Methods in Two modern plants • Oil treated — or Resin dipped faces • Mineral paint sealed edges (A LOCKTITE development) •



OREGON-WASHINGTON PLYWOOD CO.

General Offices:

1549 Dock Street, Tacoma, Washington

MILLS:

Tacoma and Everett, Wash.

CHICAGO Daily News Bldg.

NEW YORK 103 Park Ave.

LOS ANGELES 318 W. 9th St.

SAN FRANCISCO 55 New Montgomery St.

. . . and NOW



TRADE MARK

PLYSKOR®

REG. U.S. PAT. OFF. PEND.

BRINGS NEW CONSTRUCTION **ECONOMIES** AND WEATHER **INSULATION**

Plus

GREATER STRENGTH AND RIGIDITY

FOR REMODELING AND NEW CONSTRUCTION

Ask YOUR MATERIAL DEALER TO SECURE SAMPLES FOR YOU



Harborside THE SUPER-HARBORD SIDING!

HARBORSIDE'S several advantages are good reasons why it's profitable to sell this modern plywood siding. You can recommend it unconditionally—with architects' and builders' approval—because it's permanently weatherproof,* made of SUPER-Harbord, the time-tested outdoor plywood . . . guaranteed against ply separation!

HARBORSIDE comes in redwood or fir, double rabbeted at sides and ends: four feet and eight feet by 12½, 15, 18 or 23 inches, grain vertical or horizontal. It's economical to apply—easy to stock in convenient packaged units—profitable to sell—and stock is quickly available on 24 hours notice from our nearest distributing warehouse. Write for informative bulletin on HARBORSIDE.

HARBORD PLYWOOD PRODUCTS

- Harbord Plywood
- Harbord Sheathing
- Harbord Wallboard
- Harbord Plycrete (For Concrete Forms)

- Harbord Industrial Plywood
- Harbord Lauan Plywood

SUPER-HARBORD PRODUCTS

- Super-Harbord Plywood (In All Grades—in Panels as Large as 8 x 16 Feet)
- Super-Harbord Plycrete (For Concrete Forms)
- Super-Harbord Lauan Plywood
- Super-Harbord Redwood Plywood
- Harborside

MANUFACTURED PRODUCTS

- Harbord Tennis Tables
- Sag-Nott Doors (With Cotter-Keyed Joint)

MADE OF **SUPER-Harbord**

*For a weatherproof plywood, guaranteed against delamination, recommend SUPER-Harbord, "as manufactured by the exclusive patented process, hot-pressed with a cresol-formaldehyde synthetic resin binder, and then tempered."



HARBOR PLYWOOD CORPORATION

Mills and General Offices, Hoquiam, Washington

Sold at retail by progressive dealers everywhere

Distributed by

MARIS PLYWOOD CO.
510 10th Street
SAN FRANCISCO, CAL.

GEORGE E. REAM CO.
235 So. Alameda Street
LOS ANGELES, CAL.

JOHNSON & LUNDGREN
440 East 25th Street
TACOMA, WASH.

NICOLAI-NEPPACH CO.
2nd Ave. and Davis St.
PORTLAND, ORE.



"Neat, durable and insulating,
Streamliner doors
presage the trend in new
work and find particular use
in old work where elimination
of moldings and bric-a-brac
is essential."

Paul Thiry



LAMINEX *Streamliner* MEETS TODAY'S DOOR REQUIREMENTS LIGHTNESS • STRENGTH • BEAUTY • ECONOMY



• Keeping abreast of modern architectural and construction achievements, Wheeler Osgood has produced the Streamliner door.

This new development in door construction has been *engineered* to eliminate dead weight without sacrificing strength. The sturdy stiles and rails are braced,

horizontally, with twenty-four bars mortised into the stiles. Two Laminex-built panels (three ply construction) are cemented to the rigid frame, providing a door of unusual lightness and exceptional strength. The numerous advantages afforded by the *Streamliner* have led to its use in many types of installations, both in homes and in commercial buildings. The special construction and the large manufacturing facilities of Wheeler Osgood permit it to be sold at a price which provides one of today's most outstanding door values.

UNLIMITED STYLES of DESIGN and FINISH

The Streamliner lends itself perfectly to modern, period or conventional finish treatment. The plain panel surfaces offer endless possibilities. They may be stained, painted or waxed to harmonize with any interior. Innumerable panel effects may be obtained by routing.

Write for the new A.I.A. file folder giving complete information about the Streamliner door. There is no obligation.



Streamliner doors in E. C. Edwards, Georgian home, overlooking Lake Washington. Architect, Paul Thiry, A. I. A., Seattle.

A STREAMLINER DOOR



Apace with the times this door has everything that a modern door should have—beauty, lightness, strength.

HOTEL DOORS IMPROVED BY STREAMLINING

SINCE the time the early cave dweller rolled a boulder in front of the entrance of his cave, doors have protected the dweller and have been the most frequently used part of the home. The purpose of doors has always been to provide a substantial barrier yet one which would permit easy entrance and exit to the occupant, as situations require.

The first major improvement in door construction is believed to have been made in about the 5th century. At that time it was discovered that the damaging and disturbing effect of moisture could be overcome by substituting a "built-up" door for the door made from a single board or section of wood. Built-up doors first appeared in countries having a damp climate and were designed to overcome the inconvenience caused by warping. Such doors are described as being made of several sections of wood; consisting of a series of vertical planks held together by dowels or horizontal braces. Another method was to form a framework of stiles and rails and place a thinner panel between them; this panel was held in place by grooves or moldings.

It is interesting to observe that even at this early date a crude application of the principle now known as Laminex was being used as well as the application of dowels which plays an important part in the construction of doors today.

Door development has followed closely the development of architectural design. Special doors most suitable for particular styles of architecture have been made available in recent years. One manufacturer produces over 300 separate and distinct styles. The modern tendency to "streamline" in practically everything, has also influenced door design and construction.

Streamlining is principally the elimination of excessive weight by a process or method which does not reduce strength. The

(Please turn to Page 65)

WHEELER OSGOOD SALES CORPORATION
TACOMA, WASHINGTON

The Country's Most Complete Line of Doors
OVER 300 DESIGNS

"WE KNOW OF NO OTHER MATERIAL that will so satisfactorily meet the requirements of a gymnasium floor"

... say KNIGHTON & HOWELL, Architects & Engineers



... note how bright and clean-
looking is the gymnasium floor
of the Senior High School at
Astoria, Oregon, thanks to the
bright-reflecting smooth-
ness of the Hard Maple Floor
(MFMA First Grade, 25/32"
thick). Knighton & Howell
(Portland) were the architects.



IT'S easy to effect "economies" in school floors—but it's easier still to pick the one most economical and satisfactory flooring. Countless schools prove, countless architects agree, this is Northern Hard Maple.

The difference is simply that Hard Maple satisfies every consideration. Nothing practical is more durable—is cleaned and maintained so easily. Nothing is more permanently pleasing than its cheerful, natural beauty—so permanent, yet so simple to change to meet any new decorative plan. And too, warm, dry, resilient Maple, with its smooth and sanitary surface, is most favorable to student health. It anchors desks firmly, simplifies alterations—through the years is ever-practical, ever-dependable.

That is Hard Maple's record in thousands of schools—and the reason why architects, with their years of study and experience, say "Nothing else so satisfactorily meets the requirements."

When building or remodeling, ask your architect about MFMA* Northern Hard Maple (the Association-guaranteed Maple) in strips or blocks—for gymnasiums and classrooms, assembly halls and shops.

MAPLE FLOORING MANUFACTURERS ASSOCIATION

179C McCormick Building, Chicago, Illinois

See our catalog data in Sweet's, Sec. 11/76.

Write for our folder on "Heavy Duty Finishes" for
old and new Maple floors.

*To be sure of Association guaranteed grading, specify and look for the MFMA trademark (indented and stamped). The following manufacturers are licensed to use it:

- Beck, August C. Co., Milwaukee, Wis.
- Brown Dimension Co., Manistique, Mich.
- Bruce, E. L. Co., Memphis, Tenn.
- Mill at Reed City, Mich.
- Connor Lumber & Land Co., Laona, Wis.
- Sales Office, Marshfield, Wis.
- Farrin Lumber Co., M. B., Cincinnati, O.
- Holt Hardwood Co., Ocotto, Wis.
- Kerry & Hanson Flooring Co., Grayling, Mich.
- Kneeland-Bigelow Co., Bay City, Mich.
- Kneeland-McLurg Flooring Co., Phillips, Wis.
- North Branch Flooring Co., Chicago, Ill.
- Oval Wood Dish Corp., Tupper Lake, N. Y.
- Robbins Flooring Co., Rhinelander, Wis.
- Stephenson Company, L., Wells, Mich.
- Wells, J. W. Lumber Co., Menominee, Mich.
- Wisconsin Land & Lbr. Co., Hermansville, Mich.
- Yawkey-Bissell Lumber Co., White Lake, Wis.

*3 WAYS YOU CAN USE MAPLE:

1. In unselected color (natural finish) under standard grading.
2. Grouped for color tone (as "White Clear" or "Brown Clear") and for pattern effects.
3. Color finished—in Early American, Spanish Brown, Ebony Black, and other colors of startling beauty—to match any decorative scheme.

Floor with **MFMA Maple**
(NORTHERN HARD)

MODERN HOMES ARE DEMANDING WALLS OF ENDURING CHARM

Embossed
WESTBOARD
 PRACTICAL • DURABLE • ECONOMICAL

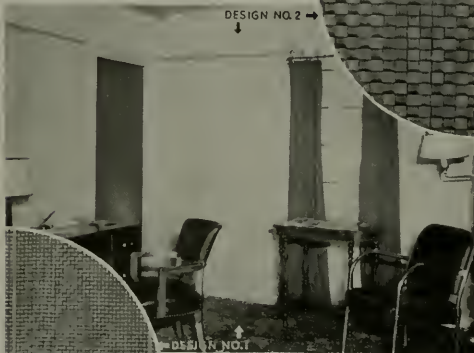

ABSOLUTELY NEW

Economical construction . . . Easy to finish to retain all of the natural beauty of fine wood paneling . . . Yet Embossed Westboard minimizes the monotony of large wood grain surfaces.

Embossed
WESTBOARD

eliminates the use of battens . . . The beveled precision edges make absolutely tight joints . . . Seamless surfaces.

Architects will welcome for its low per finished room cost and its rich room effect . . . It is not an imitation . . . It is real wood . . . New . . . Sensational in the wall panel field.

Embossed
WESTBOARD

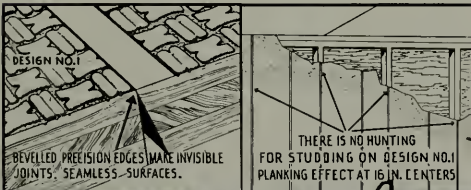

Embossed
WESTBOARD
 MANUFACTURED BY
WASHINGTON VENEER COMPANY
 OLYMPIA, WASHINGTON

Retains Natural Wood Grains



An "Embossed Westboard" Interior NEW WALL PANELING

The Washington Veneer Company of Olympia, Washington, has perfected and is now distributing to the trade a new wall paneling that promises to be a sensation in the interior finishing field. The new panels will be marketed under the trade name "Embossed Westboard."

One of the many features of "Embossed Westboard" it is low cost per finished room and its ability to give a rich room effect. The natural wood grains are retained, but are softened by the over-all embossing which comes in two patterns. Design No. 1 is a finely embossed woven effect with 3/16-inch wide, clear stripes running vertically the full length of the panel and spaced 5", 11", 8", 8" and 11" to produce a beautiful staggered planking design and also to center on 16" wall studding. Battens are not necessary.

Design No. 2 is an attractive basket weave, 1/2" x 1/2", and is particularly adapted to ceilings, drop ceilings and wainscoting or wherever decorative effects are desired. Both designs come in large panels with beveled precision edges which allow the panels to be drawn tightly together, thus eliminating the use of battens and creating beautiful seamless surfaces.

Embossed Westboard will undoubtedly find a wide acceptance among architects who are following the modern trends in interior finishing because of possibilities to cut per finished room costs and its wide variety of uses where truly natural wood finishes are desired. Embossed Westboard also fits nicely into the trend toward dry-built construction.

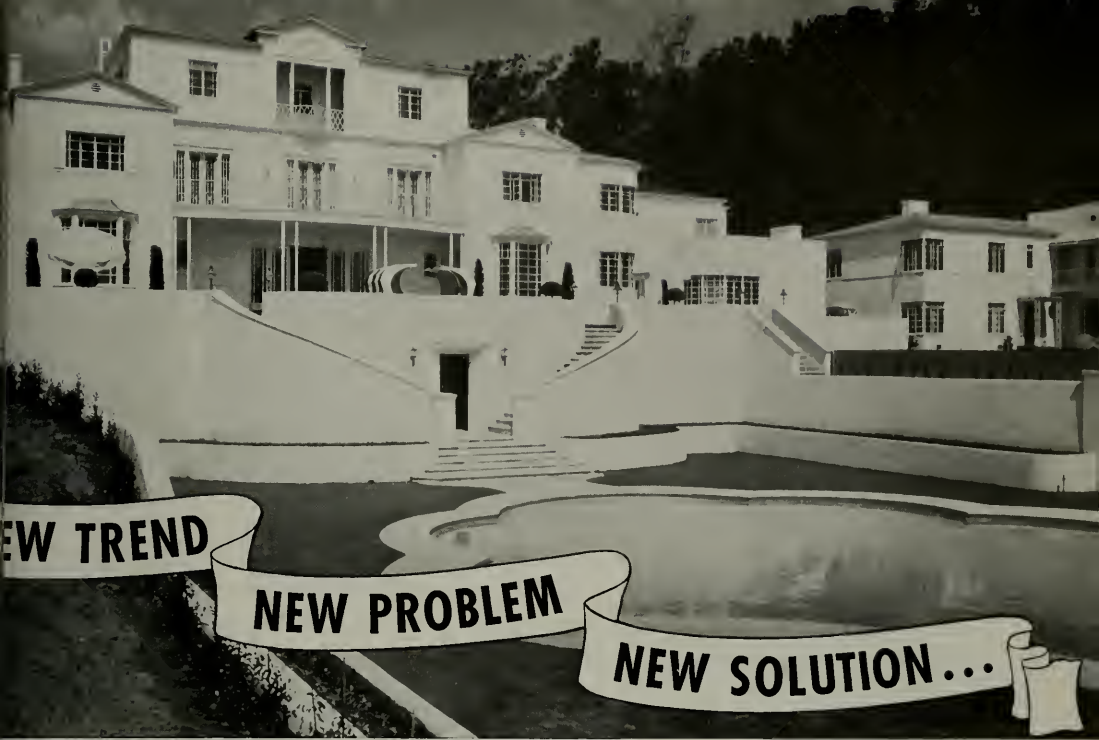

... with modern GAS appliances



SUNSET PLAZA APARTMENTS
WEST HOLLYWOOD
Architect Paul R. Williams
Assoc. Arch. Lester G. Scherer

Eighteen perfect small homes under one roof! Designed for the California climate—with generous light and air, gardens, tennis court and outdoor pool. ☆ Year-around comfort, carefree housekeeping and gracious living are assured by quick, clean, economical gas appliances. ☆ *Architects, builders, owners are invited to use the Gas Company's free engineering service.*

THE trend in apartment house design—individual homes under one roof, instead of cubicles opening from long halls. ☆ *The problem*—individually controlled heating. ☆ *The solution*—forced air, unit gas furnaces, thermostatically regulated by each family according to personal needs. ☆ There's a modern gas range in each kitchen of course; and low-cost, dependable hot water is automatically supplied with gas. Would you as an owner ever lack desirable tenants for such a property? Would you as a tenant be likely to leave it for any other home?



ENDING EFFLORESCENCE

By H. F. RIPPEY

THE destructive and unsightly condition of efflorescence in otherwise sound and attractive walls, has been a problem for many years. But its causes have never been generally understood, and therefore the efforts toward prevention or cure have never been very successful.

When I. F. Laucks, Inc., entered into the exterior painting market with Rezicote, chemists determined to find out what really caused efflorescence and how to stop it.

The result of their work is the manufacture of a new product, Laux Stopit, to be used with Rezicote on stucco, brick, masonry and concrete walls as a scientific antidote for the undesirable conditions of efflorescence.

There are a number of causes for efflorescence.

- (1) Water migrating through the walls—
- (2) Combining with the soluble alkaline salts always present in the brick, cement, stucco, or mortar and—
- (3) Bringing these salts to the surface where the drying action of the air crystallizes them in the familiar blotches we associate with efflorescence. (Sides of buildings more exposed to sun or wind tend to show more efflorescence on this account.)

If there are any decorative coats on the wall they are forced off by this action underneath them or the oils or free fatty acids in the paint coat itself combine with the alkaline salts, saponify (turn soapy) and run down the surface of the wall . . . a common, if less familiar, manifestation of efflorescence.

The water from which all this trouble arises, usually comes from a foundation with "wet feet" or from a roof with faulty flashings, or it may enter the wall through leakages within the building itself or from weather conditions. In any event it passes throughout the wall . . . often for several stories . . . by **capillary action**, the same action as found in a wick or a loaf of sugar dipped into a cup of coffee.

So far there has never been a paint made that could counteract this combined chemical and mechanical action of efflorescence. It will remove even the strongest and most waterproof paints, such as aluminum paint. The real difficulty is that while a paint may stop actual moisture movements at the surface, there are none that arrest the vapor, which is just as damaging in this regard.

(Please turn to Page 63)

Solved: How to Paint Plywood

REZITEX *for outside*
TRADE MARK



PLASTEREZ *for inside*
TRADE MARK

LAUX
ESTABLISHED 1908

2 ENTIRELY NEW Paint Products

BOTH PAINTS formulated to be ideal wall coatings for plywood . . . REZITEX over sealed *Certified* exterior plywood, PLASTEREZ over sealed interior plywood.

- Synthetic resin base assures durability (no water).
- Genuine artistic beauty, to simulate stucco, plaster, etc.
- Hides joints, grain, minor imperfections, etc.
- Takes additional decorative coats without priming.
- FIRE-RESISTANT!

Economical...one or two coats cover...speedy!

Send for Complete Descriptive Booklets

★ SEATTLE · LOS ANGELES
OAKLAND · SACRAMENTO

I. F. LAUCKS, Inc.
ESTABLISHED 1908

★ PHOENIX · DALLAS
VANCOUVER, B. C.



ASK YOUR CLIENT:

"Why get rustable pipe when Anaconda Copper Tubes cost hardly any more?"

Copper Tubes...*the outstanding "buy"*

for low-cost, durable piping

1. Anaconda Copper Tubes, assembled with "solder-type" Anaconda Fittings, cost scarcely any more than piping that rusts.
2. Copper Tubes eliminate rusty water and rust-repair bills for all time.
3. They not only last longer . . . they look better. Their sleek lines enhance the appearance of basement rooms.
4. Copper Tube *heating lines* are more efficient, give faster flow, cut the operating cost of a forced circulation heating system.
5. The Anaconda line of copper tubes and fittings is complete. Carried in stock by leading Pacific Coast supply houses. 8831



Anaconda DEOXIDIZED Copper Tubes

THE AMERICAN BRASS COMPANY • General Offices: WATERBURY, CONNECTICUT
In Los Angeles, 411 West Fifth Street . . . In San Francisco, 235 Montgomery Street . . . In Seattle, 1338 Fourth Avenue

INLAID PLYWOOD—For Beauty



BREAKFAST NOOK, RESIDENCE OF ALDEN BAYLEY, SHELTON, WASHINGTON
Walls of Art-Ply, an inlaid plywood

IN KEEPING with the trends in modern home building the idea of dry wall construction has become a matter of importance to architects and builders everywhere and suitable materials to be used for this purpose are being closely investigated.

To measure up to the standard required a material of this nature must contain both the elements of stability and long life and must be so manufactured that proper interior decorative effects may be obtained. Paints, stains and enamels are known to be the ultimate in obtaining these results but first the base material must be satisfying. This is found in Art-Ply, an inlaid plywood, manufactured by the Vancouver Plywood & Veneer Co., of Vancouver, Washington.

This material has been on the market for the past two years and its acceptance by the architectural profession has proven its merit. It is and has been sold in every state in the Union with many fine installations in homes and interiors of other types of buildings.

Outstanding features of Art-Ply are the sealed and invisible joints which eliminate the batten so commonly used. Also the distinctive patterns obtained by the inlaid mouldings, forming both tile and plank effects and breaking up an otherwise blank surface so noticeable in other wall materials. Grain raising and checking are eliminated.

Plywood as the basic material used in the manufacture of Art-Ply thus enters a field that is a natural with unlimited potential possibilities architecturally. The accompanying picture shows a living room finished in this material and graphically illustrates its possibilities.

KRAFTWOOD—For Refinement



CORNER OF BREAKFAST ROOM, HOUSE OF C. B. MALARKEY, PORTLAND, OREGON
Johnson, Wallwork & Dukehart, Architects
Walls and ceiling of Kraftwood

THE good appearance of fine wood paneling and the economies of plywood have been finally combined into one building material. A product copyrighted as Kraftwood has been perfected by the M and M Woodworking Company of Portland, Oregon, and is now available.

The new plywood paneling has a distinctive Tudor grain indented into the wood. The graining does two things—it replaces the very large uneven graining of ordinary plywood with a refined, handsome pattern, and it eliminates the checking and grain raising tendencies of ordinary plywood. The new surface is easy to finish. Two coats give a satisfactory and permanent finish. Three coats are all that are required for a beautiful two-tone effect.

The new plywood is redried and resin sealed on all sides at the factory to eliminate shrinking, warping and twisting. One Kraftwood millinery display window in Portland, Oregon, subjected to severe summer heat, reveals no twisting or opening of the joints.

All Kraftwood panels are scored with attractive grooved patterns to resemble fine grain wood paneling. All edges are v-grooved so that when two panels are butted together a groove is formed which resembles the grooves of the panel patterns. This grooved joint gives a smooth, attractive wall free from battens. No gluing or stripping is required at the joints. The plywood is available in standard sizes four feet wide by eight feet long. Ten and twelve foot lengths are also available. Two ceiling patterns have also been developed. Standard ceiling panels are four feet square.



**NEVER GETS OUT OF
ADJUSTMENT . . .**
BECAUSE there's nothing to adjust



• The sun always rises in the east—and Sloan Royal Flush Valves work with equal certainty. In neither case is there anything to adjust, the operation being automatic. Sloan Flush Valves, over a period of years, save an immense amount of water over all tank toilets, and very frequently over other types of flush valves. The reason for that lies in the design of Sloan Valves and the precision with which they are manufactured. Maintenance costs on Sloan Valves usually range between $\frac{1}{2}$ and $1\frac{1}{2}$ cents per valve—per year.

Reason enough why more Sloan Flush Valves are used than all other makes combined.

SLOAN VALVE COMPANY • CHICAGO



SLOAN *Flush* **VALVES**

MAKERS ALSO OF THE "STAR"  "NAVAL"  AND "CROWN"  VALVES



COLUMBIA BROADCASTING STUDIO, HOLLYWOOD, CALIFORNIA
WILLIAM LESCAZE, ARCHITECT
EARL HEITSCHMIDT, ASSOCIATE ARCHITECT

An unusual treatment for exterior finish was the use of plywood forms with the grain running vertical instead of horizontal.

PLYWOOD BECOMES AN INFLUENCE IN DESIGN

By JOSEPH WESTON, Architect

MOST of us think we know all about plywood. The fact has penetrated our consciousness that it is the most economic concrete form material now available and one which meets the multiple demands of designer, engineer and erector. We see plywood on all sides of us, in our case work, in the frame of the doll buggy, in furniture, in doors, in trunks, in freight cars, and in innumerable other places. And it is presumed that the interesting Douglas fir plywood developments in the experimental residences produced by the Forest Products Laboratory have been followed.

However—the material has been so easy to handle, its uses have been so broad, its misuse has been so flagrant that the following questions would seem appropriate. Are we sufficiently informed as to the grades, sizes and thicknesses of Douglas fir plywood panels now on the market to specify them appropriately and with the greatest economy? Is it possible that our eyes have been blinded to the inherent beauty of the wood? Can the trained imagination of the architect, coupled with full knowledge of grades and glue principles, increase the handsome appearance of the material through design, pattern and effective finish surface?

The first questions answer themselves. The last one can have an affirmative answer only.

It may be that all of the designers of the West Coast have not seen beyond the dirty brown stain that appears to have tacked itself on to Douglas fir plywood usage, but, if anyone will go to a lumber yard and ask to see a few panels with "good" faces, the challenge of those unfinished pieces of wood will be sufficiently stimulating to demand new design uses and appropriate finishes. Further, they cannot

help but forever eliminate any feeling other than the deepest respect for the beauty (in the most extended meaning of the word) of the material.

UNLIKE ANY OTHER MATERIAL

As stated, the strength of plywood is demonstrated in its use as concrete form material, in which capacity it has proven its ability to sustain the concentrated loadings of wet concrete.

With strength, beauty, low cost of material and application, coupled with immense production facilities and a distribution system which makes the panels available at the nearest lumber yard, Douglas fir plywood finds itself unlike any other material, and it is certain that as increasing architectural and engineering experience is gained with plywood, fields and uses now unthought of will come forward.

It is certain also that plywood will serve as the integrating factor in the architecture of tomorrow. In illustration, the pattern of exposed concrete work is now being hinged upon the plywood form. The new C.B.S. studio in Hollywood by William Lescaze, architect, with Earl Heitschmidt, associate, is an example of such a design.

Architects are, unconsciously or otherwise, approaching the surface appearance of their monumental structures with the pattern effect of form panel material in their minds. This will grow, because the elevation of concrete from that of a core, to that of a splendid and flexible material which is not only structural but which is fine to look upon, is basically sound. It is an advance which, if not allowed to lose itself in poorly conceived detail, has all the possibilities of developing an architectural style with all the qualities necessary to place it on the same pedestal with the Parthenon or Chartres.

PLYWOOD FORMS GIVE BEAUTY TO EXPOSED CONCRETE



GENERAL VIEW OF COLUMBIA BROADCASTING STUDIO, HOLLYWOOD, CALIFORNIA

WILLIAM LESCAZE, ARCHITECT

EARL HEITSCHMIDT, ASSOCIATE ARCHITECT

Referring to the use of Douglas fir plywood for form work, Mr. Lescaze, the architect, says: "Panels were used with the long dimension running vertically and 2x4s 12" on center were used for bracing. No bulging resulted. The smooth finished surface has proved very satisfactory. No attempt was made to conceal the joints between the panels which add materially to the beauty of the surface."

It is said that Bertram Goodhue used to introduce every new man who came into his office, to Professor Lethabys' "The Art of Architecture." In the last chapter of this book, entitled "The Modern Position" written fifty or more years ago, concrete's future was accurately forecast, although the author did not fully realize that one of the governing influences on this growth would be the form material. To those, however, who are acquainted with the worthy Professor's writings, it is obvious that he would have credited plywood form material with being one of the vital impulses necessary to carry concrete to the design heights it has reached today.

AIDS SIMPLIFICATION OF PLANS

In houses, a great deal of consideration has been given "integration"—"Modules." Sifted

from the maze of words, written and spoken, a few things stand out. The depth of a 2x4 stud, and the sixteen inch spacing of joists and studs, represent the two dimensions which affect more items in a house than any others which can be determined. The medicine case, the ironing board, the electric wall heater, in fact everything which goes *into* a wall has crystalized, and is based upon 2x4's—16.

In like manner, where larger elements are used, it is economical and logical to use four feet and eight feet, both dimensions of which are multiples of two inches, four inches and of sixteen inches. A four foot module (which is not too large to meet the demands of floor plan) therefore ties so directly and so naturally to a four foot sheet of Douglas fir plywood, that it seem so obvious that the 4x8 plywood sheets of

subfloor, sheathing, interior wall and ceiling panels, are destined to furnish the unit of size around which we may plan our frame buildings, and the controlling element needed to simplify our plan approach, just as the floor mat of Japan is the controlling modular area which simplifies their planning without limiting variety of perimeter. It is interesting to note, parenthetically, that the Japanese mat, developed over hundreds of years, is approximately 4'x8' in size.

It is realized that the professional man in practice, and this applies particularly to the architect, is called upon to train himself in so many subjects that it is not surprising to find many who place all their Douglas fir plywood thinking in one basket, and others who have not found the opportunity to acquaint themselves with the various grades that have been developed to meet a vast number of problems.

The Douglas fir plywood industry has been brought to established standards as recorded by the National Bureau of Standards of the U. S. Dept of Commerce, and the manufacturers of the material are joined in the Douglas Fir Plywood Association which has an independent inspection force whose duty it is to maintain grade standards so that the purchaser may know that if he specifies, for example, plywood of concrete form grade, manufactured expressly for this use, he is protected by a distinguishing mark so that in his supervision he may easily check as to whether the proper material, as specified, is being used.

HAS STRUCTURAL AND BEAUTY VALUES

The user of Douglas fir plywood may, of course, refer to his catalogues for technical description of the material, but in general it is well to carry in mind the fact that all grades are structurally sound, but that three general glue



NEW PHILHARMONIC BUILDING, FORMERLY THE AUDITORIUM, LOS ANGELES
Douglas fir plywood protective covering used while old face of building is being lifted for new.



STUDY, HOUSE OF DR. B. A. G. FULLER, HOLLYWOOD, CALIFORNIA
RALPH C. FLEWELLING, ARCHITECT

This interior reflects the wide adaptability of Douglas fir plywood in creating the modern motif now so widely demanded for interiors.



ANOTHER VIEW OF THE FULLER STUDY. THE FINISH A SOFT GREEN DADO, UPPER WALL ALUMINUM AND WHITE, WITH MAROON CEILING, THE LATTER REFLECTING COLOR OF RUBBER TILE FLOOR.

lines are in use and that several faces, several thicknesses, and a variety of sizes are on the market.

The standard glue used is stronger than the wood which it bonds, and will withstand any normal interior use, but is not offered as being waterproof. The concrete form panels are manufactured with a special water-resistant glue which has proven its ability to stand up under the severe treatment to which any concrete form material is subjected, to be good for from 7 to 15 reuses and still be satisfactory as subfloor or sheathing.

For permanent exterior application, or for use where conditions of extreme dampness or humidity apply, a third basic glue line is utilized, namely, a synthetic resin which is insoluble in water and which is manufactured by what is known as the hot plate process wherein heat and great pressure are combined to make the binder effective.

As to surface, this can hardly be briefed, but



STRIKING EXAMPLE OF THE USE OF STAIN TO BRING OUT THE NATURAL BEAUTY OF DOUGLAS FIR GRAIN

Used in this manner plywood adds a contrasting effect to the interior decoration.

it would be well for the user to know the difference between a "sound" face and a "good" face. "Good" faces are the especial beauties, and to quote Department of Commerce Standards "shall be of a single piece of smoothly cut veneer of 100 per cent heart wood."

A "sound" face, intended for painted jobs, "shall be of one or more pieces of smoothly cut veneer. When of more than one piece, it shall be well joined and reasonably matched for grain and color at the joints."

In closing it should be brought out that Douglas fir plywood enjoys the most secure future of any element in the building field. It is used in conjunction with steel and wood, it serves as the mould which shapes concrete, and as a base for synthetics. It finds its place in new work and is most adaptable in alterations. It has structural value, it has appearance value and it is not a substitute nor an imitation of anything else. It is genuine in its own right, and it stems back into peoples' sentiments because it is wood.



DINING ROOM, FROM LIVING ROOM, HOUSE FOR PROFESSOR ROBERT TRYON, BERKELEY. (Exterior view on Page 21.) NATURAL FINISH, RIBBON GRAIN MAHOGANY WALLBOARD, TEAK FLOOR.



DETAIL OF ENTRY, HOUSE FOR JOSEPH HENRY JACKSON, BERKELEY,
CALIFORNIA

MICHAEL GOODMAN, ARCHITECT

Interior finish of light ribbon cut mahogany plywood.

FOUR HOUSES IN BERKELEY

By MICHAEL GOODMAN, Architect

- I House for Professor Robert Tryon, Pages 19 and 21.
- II House for Joseph Henry Jackson, Page 20.
- III Studio for Professor Robert Tryon, Pages 22 and 23.
- IV House for Edgar Taylor, Page 24.



HOUSE FOR PROFESSOR ROBERT TRYON, BERKELEY, CALIFORNIA
MICHAEL GOODMAN, ARCHITECT
Exterior of $\frac{1}{4}$ " plywood panels over sheathing used experimentally.



LIVING ROOM FROM UPPER LEVEL, STUDIO HOUSE FOR PROFESSOR
ROBERT TRYON, BERKELEY, CALIFORNIA
MICHAEL GOODMAN, ARCHITECT

Interest in this house centers in the unique arrangement of the plan. The entire floor area is only 28 x 28 with living room, pictured above, occupying three quarters of that space. The view combines entrance, living and dining space. Entrance steps are at extreme left. Back of the fireplace on the right is the kitchen, above which is bed room and bath.



STUDIO HOUSE OF PROFESSOR ROBERT TRYON, BERKELEY, CALIFORNIA
MICHAEL GOODMAN, ARCHITECT

Combination of entrance, living part and dining space of the Robert Tryon studio or guest house, Berkeley. Interior finish is ribbon cut mahogany plywood, Salvich teak wood floor, brick fireplace with tile hearth, natural finish Venetian blinds, gray Celotex ceiling. Artificial lighting is by floor and table lamps.



LIVING ROOM AND DINING SPACE, HOUSE FOR EDGAR TAYLOR,
 BERKELEY, CALIFORNIA
 MICHAEL GOODMAN, ARCHITECT
 Plywood walls and ceiling.



INTERIOR OF HOUSE FOR J. D. FIELD. THE STAIRWAY,
 LEADING TO BALCONY AND SECOND FLOOR, IS DOUGLAS
 FIR PLYWOOD. NOTE CURVED CEILING.



AN INTERESTING TREATMENT OF DOUGLAS FIR PLYWOOD
 IN THE MEIER & FRANK STORE WINDOW, PORTLAND, ORE-
 GON. BACKGROUND AND CUT-OUTS ARE PLYWOOD.

FINISHING DOUGLAS FIR PLYWOOD

By G. N. ARNESON

Chief of Research Section of Douglas Fir Plywood Association

DOUGLAS fir plywood offers an almost limitless variety of possibilities for finishing interiors, including wallpapering, natural, staining, painting, and mechanical surfacing. Each treatment allows for an infinite number of variations, depending on the exact effect desired.

In general, however, the same broad considerations govern each group and the quality of the finished product will depend greatly on the materials used and the care exercised by the workmen in applying the finishes.

The plywood panels are sanded to an even smoothness before they leave the mills and unless soiled through handling and rehandling in transit are ready for preliminary finishing just as they are delivered. After installation, sanding of the joints and the nail holes, together with a thorough dusting, should prepare them for the finishing.

NATURAL WOOD FINISH

Sealing with one of the new clear resin sealers should be standard practice for the natural wood finish or for stained finishes. This has the effect of producing a softened grain-tone and both moisture-penetration and grain-raising are minimized.

Panels are also available with the sealer applied in the mill, immediately after mill-sanding. This treatment prevents the subsequent stain-coat from penetrating into the softer spring-wood of Douglas fir, and thus effects an even distribution with a softened grain tone.

An economical, attractive finish in natural wood consists simply of two coats of clear lacquer, with a finish of wax, sanding after each coat.

STAINING

In staining, the effect that is obtained is very similar to that on hardwoods, the only



THE STRAIGHT EDGED FELT IS TIGHTLY BUTT-JOINTED, PROVIDING A SMOOTH SURFACE FOR THE PAPER.



UNDER WALLPAPER, THE SKILLED DECORATOR PREFERS A BASE OF FIR PLYWOOD. IT IS BEST TO USE A 3/4 LB. DEADENING FELT OVER THE PLYWOOD.

requirement being that the stains must be allowed to stand longer than when applied over an untreated wood surface. When oil stains are used, the operation is more that of glazing, and the stains in general must be heavier bodied than when used over untreated or raw wood. The result is so unusual to fir that in many places stained fir panels can be used where only hardwoods were previously considered suitable.

Steps to produce stained finishes may be tabulated as follows:

Flat Stain	Gloss Stain	Lacquer
Stain	Stain	Stain
Coat of Shellac	Shellac	Lacquer Sealer
Sand	Sand	Clear Lacquer
Flat Varnish	Gloss Varnish	(Flat or Gloss)

PAINTING

Painting technique, as well as panel application and joint treatment, should aim to guard against definitely preventable defects which occasionally occur, i.e., fine hair-checking and hair-cracks at panel joints. This can be prevented if panels are thoroughly dry at installation and if they are primed or sealed soon after. Correct joint filling also provides an elastic expansion joint to eliminate cracks in the paint film.

Brush stippling, and to some extent a plastic finish, is extremely popular as a practical and attractive surface since each type conceals thoroughly any minor blemish or checking in the plywood which might be noticeable in the glossy finishes.

WALLPAPER OVER PLYWOOD

Plywood's popularity as a base for wallpaper is attributed to its freedom from cracking, its smoothness, its large panel size and ease of

erection, and the general economies obtained through its use. Experienced decorators have found that by following a more or less standardized technique, an almost ideal wallpaper job can be obtained over Douglas fir plywood.

The wallboard grade of plywood panels should be closely butted with joints filled with a good joint filler, such as plastic wood, Swedish putty, or similar material. After the filler has dried the joints should be lightly sandpapered.

The panels should now be coated with a wheat flour paste to which has been added a gelatine size. Over the plywood a layer of $\frac{3}{4}$ -pound deadening felt is applied after it has been treated with the same paste and size.

The felt should be butted neatly at the joints, rolled and smoothed. From the ceiling it should run down about one inch on the sidewall so that the strips applied to the sidewall will lap over the ceiling strips about one inch. Many decorators also go over the felt with a smooth brush to assure uniform adhesion to the plywood.

When the felt has been entirely installed the wallpaper is hung in accordance with standard practice, using ordinary wheat flour paste.

A more economical job can be obtained by eliminating the felt, but the felt is recommended as it serves to bridge over the joints between the panels. The felt also adds to the insulation and sound-deadening properties of the wall.

For modernization and repair jobs where old walls have become badly cracked, plywood can be installed by nailing it to the studs or wood frame and following the procedure described above.

FROM SUMMER COTTAGE TO PERMANENT HOME

THE pictures show the transformation of a \$2,500 summer cottage into a \$10,000 permanent home as it was accomplished by Harrison Clark of Lake Steilacoom, near Tacoma, Washington, from plans by Silas E. Nelson, architect.



THE \$2500 SUMMER COTTAGE OF HARRISON CLARK ON LAKE STEILACOOM, NEAR TACOMA, WASHINGTON, BEFORE ALTERATIONS



THE CLARK HOUSE AFTER ALTERATIONS AND ADDITIONS. ROOF IS RED CEDAR SHINGLES APPLIED TO 5/16" DOUGLAS FIR PLYWOOD SHEATHING
SILAS E. NELSON, ARCHITECT

The remodeling was so extensive that even on the interior it is difficult to point out the old from the new except in one room, the kitchen, which has remained intact. Yet it is interesting to note that actually all of the old home is a part of the new home and no materials were discarded in the remodeling.

The cottage had a living room, three small bedrooms, kitchen, dinette and bath, with no basement or attic.

The completed house has a full basement on the lake-side level with laundry room, air-conditioning furnace, fruit rooms, fuel bins and ample space for rumпус room.

On the level above, which is the main floor, there is a large garage and work room, a spacious living room generously supplied with windows, two large bedrooms, a study, dining room, kitchen and bath.

The attic level will eventually be converted into two additional bedrooms, a bath and a children's playroom.

As will be noted from the exterior views, the house was extended toward the lake (these pictures were taken from the lake side) so that the living room now occupies all of the space taken by the original porch. The house was likewise extended to the left to meet the widest dimension of the original roof. The extension of the house toward the lake made possible a very much enlarged dining room at the right and the new porch leading from the living room.

The home is sheathed throughout with 5/16-inch Douglas fir plywood and the shakes and shingles which are used on the exteriors are applied directly to this sheathing.

Subflooring is 5/8-inch Douglas fir plywood in every room, although the finish flooring varied from floor tile to carpeting.

All interior paneling is 1/4-inch Douglas fir plywood and it is subjected to various finishes. The walls of the living room, dining room and bedrooms are papered after a layer of 3/4-pound deadening felt had been pasted to the plywood and the paper applied to the felt, according to standardized technique. The face plies of the plywood used in the entry hall are knotty pine and the face plies of the fireplace wall of the living rooms and the wainscot in the dining room are of knotty cedar. These are finished natural with two coats of clear



CONSTRUCTION PICTURE DURING REMODELING OF THE HARRISON CLARK HOUSE. DOUGLAS FIR PLYWOOD USED FOR CLOSET AND BUILT-INS.

shellac, sanded smooth, and a final coat of flow varnish.

The bathroom and kitchen are painted, with the plywood panels given a gloss enamel finish.

The ceiling treatment consisted of pasting felt to the plywood panels, then applying blank stock and calsmining to give the soft effect desirable for ceilings.



A STAIRWAY OF PLYWOOD IS FINISHED NATURAL WITH WHITE SHELLAC AND WAXED TO GIVE A SOFTER GRAIN TONE.



HOUSE FOR EARL L. HOFFMAN, LOS ANGELES, CALIFORNIA
LEO F. BACHMAN, ARCHITECT

Insulated to meet unusual changes in weather and structurally adequate for any extreme test.



REAR VIEW OF HOFFMAN HOUSE, LOS ANGELES, CALIFORNIA
LEO F. BACHMAN, ARCHITECT



CONSTRUCTION PICTURE OF HOFFMAN HOUSE, SHOWING APPLICATION OF SISALCRAFT PAPER TO GALVANIZED WIRE, $\frac{3}{16}$ " 3-PLY DOUGLAS FIR PLYWOOD SHEATHING ON WALLS AND ROOF.



LAYING OUT ROOM DIVISIONS ON THE $\frac{5}{8}$ " PLY-SCORD SUB-FLOOR OF THE EARL L. HOFFMAN HOUSE, ILLUSTRATED ON PREVIOUS PAGE. LABOR COSTS FOR THIS TYPE OF CONSTRUCTION REDUCED 66%, ACCORDING TO CONTRACTOR. THERE WAS PRACTICALLY NO MATERIAL WASTE.



LIVING ROOM IN THE HOFFMAN HOUSE HAS $\frac{1}{4}$ " 3-PLY PLYWOOD WALLS AND CEILING, WALL-BOARD GRADE UNSANDED, PANELS PAINTED TO GIVE A ROUGH TEXTURE TO THE FINISH. THE DINING ROOM (below) ALSO HAS A CEILING OF $\frac{1}{4}$ " PLYWOOD.



PICTURE ON THE RIGHT SHOWS A STORE MODERNIZATION IN TACOMA, WASHINGTON, BY GASTON C. LANCE OF RUSSELL, LANCE & MURI, ARCHITECTS. DOUGLAS FIR PLYWOOD USED FOR ALL PARTITIONS AND CEILINGS. A GLOSSY COAT WAS GIVEN WALLS AND PARTITIONS WHILE CEILINGS ARE A PLASTIC FINISH.



A RECREATION ROOM FINISHED IN GLOSS ENAMEL, THE DOUGLAS FIR PLYWOOD PANELS BEING PAINTED. CURVED SURFACES ACHIEVED BY BENDING THE 3/16" PLYWOOD TO FIT REQUIREMENTS.





BLUE RIDGE MODEL HOME, NEAR SEATTLE, WASHINGTON
T. FRANCIS BELLAMY, ARCHITECT

Eleven thousand square feet of Douglas fir plywood for wall and roof sheathing, for basement concrete forms, for sub-flooring, for interior wall paneling and for many built-ins, were used in construction of this home designed to sell for \$14,500.



REAR VIEW OF BLUE RIDGE MODEL HOME, NEAR SEATTLE, WASHINGTON
T. FRANCIS BELLAMY, ARCHITECT



LIVING ROOM, BLUE RIDGE MODEL HOME

All windows have Venetian blinds, curtains and drapes and walls are papered.



RECREATION ROOM, BLUE RIDGE MODEL HOME, NEAR SEATTLE, WASHINGTON

The room, octagon in shape, is paneled with Douglas fir plywood. This home was awarded the Good Housekeeping Shield for excellence in construction.



HOUSE FOR A. R. BRADLEY, ALBANY, OREGON
Exterior of hot pressed resin-bonded Douglas fir plywood.



ULTRA MODERN HOUSE FOR R. A. SWANSON, ALBANY, OREGON,
FROM PLANS BY FRANK LLOYD WRIGHT; R. C. MILLER, BUILDER
Exterior of brick and hot pressed resin-bonded Douglas fir plywood with redwood face ply.



THREE YEAR OLD STRUCTURE AT MADISON, WISCONSIN, FOR U. S. GOVERNMENT PRODUCTS LABORATORY. NOTE WALLS, CEILING AND WEBS OF BUILT-UP LAMINATED ARCHES.

PLYWOOD IN ENGINEERING AND CONSTRUCTION

By N. S. PERKINS, C. E.

DOUGLAS fir plywood, having passed a satisfactory apprenticeship in its original field of paneling, wall coverings and cabinet work, is becoming firmly established in the exacting domain where structural dependability is the chief criterion.

All stock Douglas fir plywood whether sheathing, wallboard or panel grade, is made with highly water-resistant glues. The Concrete Form Panel Grade is made with a special and still more highly water-resistant glue and finally, panels for permanent exterior exposure are bonded by the hot-plate process with synthetic resin adhesives of absolute waterproof quality.

As this is being written, new commercial standards of performance for these classes of plywood are in course of preparation and printing by the National Bureau of Standards. These standards, already accepted by the plywood industry, will provide still further assurance of quality for the specifying consumer.

The use of plywood in concrete forms, temporary store fronts and fencing has been familiar to contractors for a number of years. So has the application of plywood for sub-floors, and wall and roof sheathing, and, in the case of waterproof panels, even exterior wall surfacings.

The past few years, however, have seen engineers using Douglas fir plywood as a structural sheathing and stressed covering over wood rigid frames, as in the Hall of Progress at Cleveland's Great Lakes Exposition; as gusset plates for trusses and frames—typical examples are the Del Amo Bridge near Compton, California, designed by the United States Engineer's Office, and various wood-framed oil derricks—and as a stressed covering glued to skeleton wood frames for prefabricated wall and floor panels.

A spectacular example of plywood utilization will be seen in the Federal Exhibit Building at



SPECTACULAR USE OF PLYWOOD AT THE GOLDEN GATE INTERNATIONAL EXPOSITION WHERE, IN THE COLONNADE OF STATES, 48 GIANT COLUMNS, 104 FEET IN HEIGHT, ARE BEING BUILT WITH WEBS 3" THICK, 29 PLY HOT-PRESSED, RESIN-BONDED PLYWOOD. THESE GUSSET PLATES ARE JOINED WITH SPLIT RING CONNECTORS.
T. L. PFLUEGER, ARCHITECT.



the San Francisco World's Fair where, in the colonnade of states, 48 giant columns, 104 feet in height, will be built with webs of 3" thick hot-pressed, resin-bonded Douglas fir plywood, in panels 3'-8½" high and 6' long, placed alternately at 90 degrees to sheets below to form huge crosses that will be filled at corners with heavy fir posts.

Other designs and tests throughout the country have utilized plywood as webs in built-up girders, box-beams, etc., and recently at White Salmon, Oregon, an ingenious builder used plywood as a core in large laminated glued wood arches spanning 40', thereby reducing fabrication costs and maintaining structural adequacy.

Three factors, it is believed, have contributed to this growing technical acceptance of Douglas

fir plywood. One, of course, has been the natural increase in practical experience with the material. A second is the splendid laboratory and field work conducted on plywood by the United States Forest Products Laboratory, and such technical schools as the University of Washington, Stanford University, Iowa State and others. Third is the continued improvement by the plywood industry itself in manufacturing technique and control.

Experience with plywood has built confidence. Laboratory tests have demonstrated that the engineer can design with plywood just as accurately as with other structural materials.

Plywood is made from high quality Douglas fir, a superior structural species of known mechanical properties.

In flexure, for example, we compute plywood deflection from the standard formula, using the same E as for Douglas fir, i.e., 1,600,000 lbs./sq. in., but in figuring the moment of inertia, only those plies having their grain direction parallel to the span, are considered. This means for example that a 5/8" sheathing grade consisting of five equal 1/8" plies, would have an I of .193 ins.⁴ per foot of width. The computation is simplified by taking the I for the entire cross section of 5-ply, deducting the I for the three interior plies and adding back the I for the single core, or

$$I = \frac{b \cdot h^3}{12} - \frac{12(5)^3}{12 \cdot 8} - \frac{3(3)^3}{8} + \frac{(1)^3}{8} = \frac{125 - 27 + 1}{512} = .193 \text{ ins.}^4$$

Numerous tests show that the modulus of rupture of Douglas fir plywood varies from about 8500 to 15,200 lbs. per sq. in. while the fiber stress at proportional limit ranges from about 7000 to 10,000 lbs. per sq. in. Ordinarily deflection rather than flexural strength will govern the thickness of panel to be selected. For 1/2" sanded panels, laid over 16" joist spacing, with deflection limited to 1/20 in., the uniform loading will be 100 lbs. per sq. foot.

Compression and tension are computed on the same principle, i.e. assuming that the cross-bands do not carry any stress.

In shear, the glues used are considerably stronger than the wood itself.

Large panel sizes (4' x 8' being the largest stock size) and cross-lamination of the plies, are

largely responsible for the superiority of plywood as a sheathing and bracing material (see tests at United States Forest Products Laboratory).

This in turn has led many architects and engineers to try plywood as a stressed covering in prefabricated wall and floor panels, and as a result scores of systems employing varying degrees of shop and job fabrication have been developed.

The popularity of plywood as a sheathing and wall covering material brings inquiry as to its insulation properties and the question of vapor barriers. In both instances Douglas fir plywood occupies a particularly favorable position.

Plywood is not generally regarded as insulation, although its thermal conductivity is the same as for Douglas fir, i.e. 0.78. Practically, however, in a standard wall section, the value of U for a wall lined with 1/4" plywood wallboard is .250 and it should be noted in this connection that plywood is proof against air infiltration, a real comfort factor in many areas.

As for vapor barriers, modern science says that where condensation in walls may be a fac-

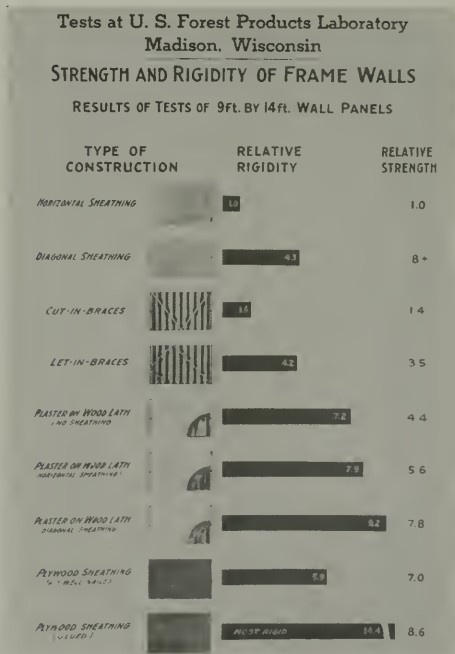



SEWER TRENCHES SHEETED WITH PLYWOOD PANELS. INSTEAD OF THE CUSTOMARY SUPPORT OF TIMBER SHEETING. STANDARD 4 x 8 FT. CONCRETE FORM PANELS OF 3/4 IN. DOUGLAS FIR PLYWOOD.

tor, due to high room humidities and low outside temperatures, the vapor barrier should be placed on the warm side of the wall, and not on the cold or sheathing side of a wall where the exit of moisture from wall cavities may be prevented.

Douglas fir plywood wallboard, with either two coats of asphalt paint on the back, or a layer of 50-lb. asphalt coated and impregnated sheathing paper makes a highly effective and economical vapor barrier, according to no less an authority than the U. S. Forest Products Laboratory.

And so the use of Douglas fir plywood grows in construction and engineering fields. Only the surface has been scratched. Unlimited opportunities seem ahead.

Only recently, in the July 21st issue of Engineering News-Record, appeared a description of a new method of trench sheeting employed in many miles of sewer construction near Chicago. The engineers used 3/4" Concrete Form Panels of Douglas fir plywood braced with screw jacks to sheet the trenches, using the panels over and over again and cutting costs 50 per cent and more. It has been predicted that this will revolutionize trench sheeting technique.

Plywood as a construction material has arrived.

Grade Description of Douglas Fir Plywood

Grade G2S The highest grade of Douglas fir plywood. Faces are in one piece, of 100 per cent heartwood, and are practically clear veneer.

Uses—For natural or lightly stained finishes, where both sides of the panel will be exposed to view.

Grade G1S One face is as good as the faces in a (Good 1 Side) G2S grade, while the opposite face or back is a "Sound" face, as described under the next grade below.

Uses—This grade is also suitable for highest quality of wall paneling, ceiling, partitions, or other surfaces where only one face is exposed, or where the back is only occasionally exposed. Light or dark stains, lacquers, waxes, etc. offer a variety of finishes.

Grade So2S Each face is smooth and free of (Sound 2 Sides) knots, splits, checks or pitch pockets. The smooth surface is suitable for painting. Sapwood, streaks or discolorations, shims, and neatly made patches are permitted. Patches and shims are inconspicuous.

Uses—For use where both faces of panels are to be exposed (as in booth partitions) and where: (1) minor blemishes will not be objectionable in a natural or stained finish, or (2) faces are to be painted.

Grade Wallboard Really a SOUND 1 SIDE panel. One face is equal to the face of a So2S panel, while the back contains sufficient defects, such as knots, splits, pitch pockets, etc. as to render it unfit for patching.

Uses—Probably the most popular plywood grade where only one face is to be exposed.

Grade: Sheathing Grading rules specify that (Trademarked PLYSCORD) one surface shall present a solid surface except that the following will be permitted: (a) Not more than six knot holes, not over 3/8" in greatest dimension, (b) splits not more than 1/16" in width and (c) not more than two strips of paper tape. The panels are scored on 16" centers and marked with the Association stamp.

Uses—A utility grade now made in 5/16", 3/8" and 5/8" thicknesses, suitable for subflooring, sheathing walls or roofs or where strength and rigidity are required.

Grade Concrete Form Panels Panels manufactured with specially highly water-resistant glues, and designed to give numerous reuses and smooth unblemished surfaces. The grade is comparable in appearance with SOUND 2 SIDES, described above. Faces are free from knots or open defects.

Uses—All concrete form plywood is so designated and is for use for concrete forms and where water-resistance is desired.

Supplementing the grades above is the strictly waterproof Douglas fir plywood, manufactured with synthetic resin glues and hot pressed.



PACK HALL, THE ORIGINAL CLASS ROOM BUILDING FOR UNIVERSITY OF WASHINGTON RESEARCH, DOUGLAS FIR FOREST, 30 MILES EAST OF TACOMA, WASHINGTON

BUILT OF PLYWOOD MATERIALS THROUGHOUT, THE BUILDING HAS SHOWN ABSOLUTELY NO MARKS OF DETERIORATION IN TWELVE YEARS.

UNIQUE OUT - OF - DOOR LABORATORY IN DOUGLAS FIR FOREST

By PROFESSOR BROR L. GRONDAL,
College of Forestry, University of Washington

ANSWERS to questions that are being asked today about the future of Douglas fir in the Puget Sound region, and questions that will be asked in the future, are being found in a unique "question-answering forest" 30 miles east of Tacoma, Washington. This forest covers an area of 2,105 acres, and includes a stand of 25 million board feet of valuable merchantable timber that is all available for demonstration. It is owned and managed by the College of Forestry of the University of Washington, and is officially designated the "Charles Lathrop Pack Demonstration Forest."

Funds for the purchase of the land and timber of this forest, as well as much of the equipment used, were provided by the late Dr. Charles Lathrop Pack of Lakewood, New Jersey, lumberman and president of the American Tree Association, who felt that actual demon-

stration to the public would advance the practice of forestry more rapidly than any other single agency. The site for the forest, bordering on the Rainier National Park Highway, was chosen to make the forest readily accessible to the public, and several miles of good roads lead to all major points of interest.

While the primary purpose of the forest is to demonstrate the effectiveness of various silvicultural systems, it has proven to be an ideal practical out-of-door laboratory for forestry students as well. The area includes soils of varying characteristics, site conditions of all classes, exposures of all kinds and elevations that reach as high as 2,000 feet above sea level. There are stands of old-growth Douglas fir, mixed stands, young stands and burned over areas. Experimental plantings of many kinds of trees are available for study, with accurate

records that are always at hand.

So, every spring and summer, a large class of forestry students from the University of Washington comes to the forest for field work in forest surveying, cruising, forest mensuration, nursery practice and practical studies in silviculture. These students must reside on the forest for a minimum period of three months, and this has made necessary the building of adequate quarters for both students and faculty.

When the forest was first established in 1925, temporary accommodations for students were hastily constructed, as funds for permanent buildings were not available. One large building, which included offices and a large class room was, however, at once constructed. As this building was intended for permanent use, a real problem presented itself, for the conditions under which it had to serve were exceptionally severe. It was necessary to hold costs of building to a minimum. During the fall and winter months the building was to be unoccupied. The heavy rainfall in the forest during these months, and the high prevailing humidity, made the use of lath and plaster in finishing this building inadvisable.

Tests of all available materials that could be used instead of lath and plaster were carefully conducted. Insulating materials that developed a musty odor after long exposure to atmospheric moisture were promptly ruled out. Strength tests were conducted in the laboratories of the College of Forestry to determine whether proposed materials would withstand accidental contact with furniture and field equipment. Furthermore, the contribution that proposed materials would make to the structural strength of the building was investigated. The cost of applying the walls was estimated. The extent to which air-infiltration could be prevented was studied. Tests to determine the heat-insulating effectiveness of various materials were made, as proper heating of the building with stoves was a real problem. Finally, the ease of finishing the interior of the building at minimum cost so that it would present a permanently attractive appearance was considered. And when everything was summed up,

there was only one answer: Douglas fir plywood.

Tests demonstrated the fact that Douglas fir plywood was so much stronger than any other material that could be used that maintenance costs would be at the lowest possible figure. Plywood was, therefore, used throughout the building. A short time later, a large log gatehouse was constructed at the entrance to the forest. The interior of the gatehouse was also finished in Douglas fir plywood.

In 1937 it became possible to complete the building program that had originally been planned when the forest was established. All of the old temporary "shacks" that had served for twelve years were torn down, and again the problem of choosing the proper materials for permanent structures presented itself. All framing lumber for the new building was cut in the forest sawmill, Douglas fir being used throughout. All buildings were roofed with Western red cedar, cut in the shingle mill owned by the College of Forestry, and all exterior walls were covered by double coursing with similar shingles. And when interior construction was considered, the original class room building was carefully examined. Good as new! No deterioration could be detected. Each year, when the classes arrived at the forest, this building was ready for use at once. No preliminary "drying out" period had ever been needed. The plywood had performed in the expected manner that tests had indicated, and even in the gate-house, which had never been heated, it was in perfect condition. So Douglas fir plywood was chosen for all new construction.

The recreation hall deserves special mention. During 1935 a C.C.C. camp was established on a portion of the forest, and a picturesque hall was built by the young men as a worthwhile project. This hall is a log building that was unfortunately so hard to heat, due to air infiltration, that it failed, rather dismally, to attract students. During the building program just completed, this building was lined with Douglas fir plywood, and now is one of the most popular structures on the unique university campus-in-the-woods. And it is just as picturesque as ever!

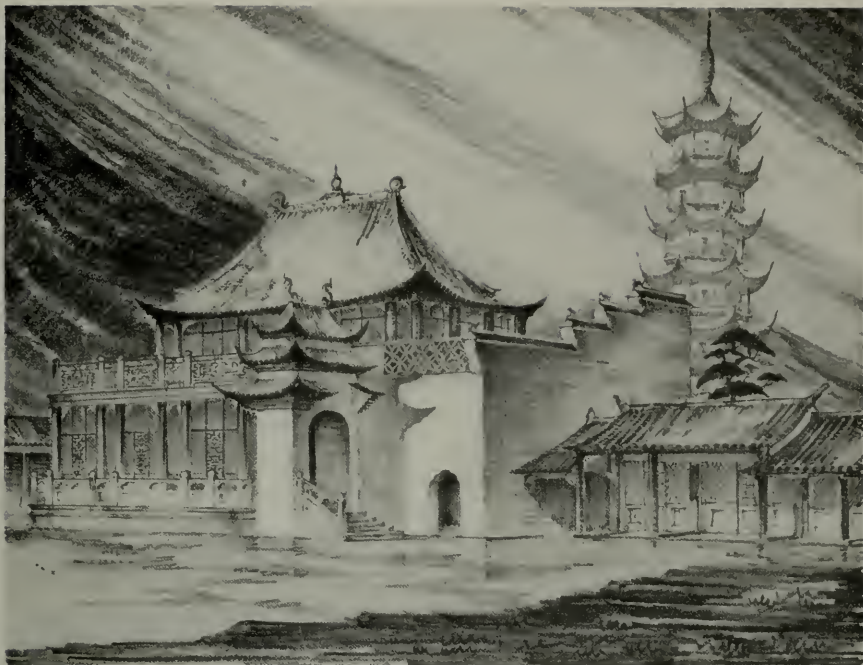

THEATER, CHINATOWN, GOLDEN GATE INTERNATIONAL EXPOSITION
MARK DANIELS, ARCHITECT
Exterior walls, plywood panels.

CHINESE ARCHITECTURE AT THE EXPOSITION

By MARK DANIELS, A.I.A.

IN that two-acre concession at the Exposition which the public has determined to identify as the Chinese Village, regardless of legal titles, types of architecture will be employed that cover many of the important provinces of China.

We occidentals are prone to form hasty mental pictures of the art of foreign countries based on the superficial knowledge that we gather from the few who have touched upon the coast or boundary lines of those countries. This is particularly true of China, for nearly all of us picture Chinese art and architecture as

that which comes from the coast provinces, yet far to the west along the borders of India and Tibet and to the north bordering on Mongolia are provinces with beautiful styles of architecture that are foreign to nearly all of us.

In an effort to give a more general representation of the architecture of China in general, many plans have been drawn predicated upon the styles of the great western provinces of Kensu, Szechuan and Yunnan. There will be buildings in this concession that picture the styles of architecture of Peking, Jehol, Shang-



ENTRANCE TO THEATER, CHINATOWN,
GOLDEN GATE INTERNATIONAL
EXPOSITION

MARK DANIELS, ARCHITECT

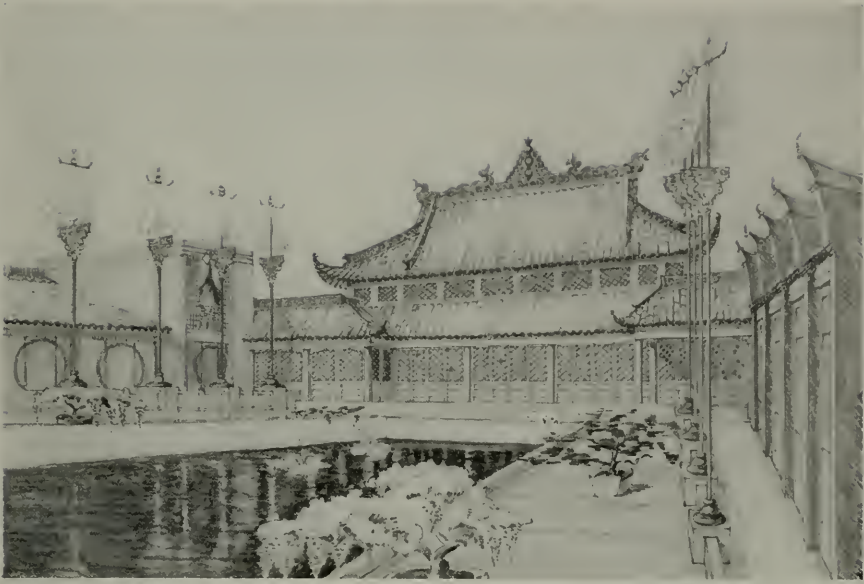

POOL AND ADJACENT BUILDINGS, CHINATOWN,
GOLDEN GATE INTERNATIONAL EXPOSITION



DER LING (EXHIBIT BUILDING), CHINATOWN,
GOLDEN GATE INTERNATIONAL EXPOSITION



EXHIBIT BUILDING, CHINATOWN, GOLDEN GATE INTERNATIONAL EXPOSITION

MARK DANIELS, ARCHITECT

hai, Canton, Kuanhien and Yenchoufu. Obviously, it will be impossible to carry out in accurate detail the ornaments and decorative features that are employed in these various provinces. It took the master craftsmen of the country hundreds of years to carve and enamel work such as the types that are to be represented at the exposition, and despite the great advance in science we have yet to learn how to do masterpieces of sculpture and color with the speed of the kodak.

The pagoda will probably be the dominating structure of the village. It is to be approximately 130 feet in height and will be located in a Chinese garden at the northern end of the concession. The next most dominating picture will be the cafe which is designed as a two story structure with ornamental entrance pailou in the style of Yenchoufu. The main entrance

from the Gayway is a pailou some 48 feet in height which is richly carved and elaborately ornamented. At the northeast corner of the village is located a temple of considerable importance and unusual beauty.

One of the most important buildings in the village will be the Princess Der Ling Pavilion. In this structure the Princess Der Ling will house and display some of her most precious collection of models and fabrics and objets d'art which were given to her by the late and last dowager Empress.

With the multicolored and highly ornamented surfaces, the swinging and flaring cornices, the banners and carvings that are authentically Chinese, it is to be expected that the realistic reproduction of a foreign country's art and culture will be one of the most spectacular sights to be seen at the Exposition.

Portfolio of ARCHITECTURAL PLATES of Douglas Fir Plywood Paneling

Prepared by CARL F. GOULD, F. A. I. A.

INTENDED AS SUGGESTIONS TO THE ARCHITECT AND BUILDER AS A POSSIBLE WAY OF APPLYING DOUGLAS FIR PLYWOOD AS DECORATIVE PANELS IN MODERN HOUSE AND SHOP DESIGN. DOUGLAS FIR PLYWOOD IS MANUFACTURED IN MILLS LOCATED IN THE STATES OF WASHINGTON AND OREGON AND IS PRODUCED FROM SPECIALLY SELECTED "PEELER" LOGS CUT FROM VIRGIN FORESTS ON THE WEST SLOPE OF THE CASCADES AND COASTAL DISTRICTS OF THE NORTHWEST AREA OF THE UNITED STATES.

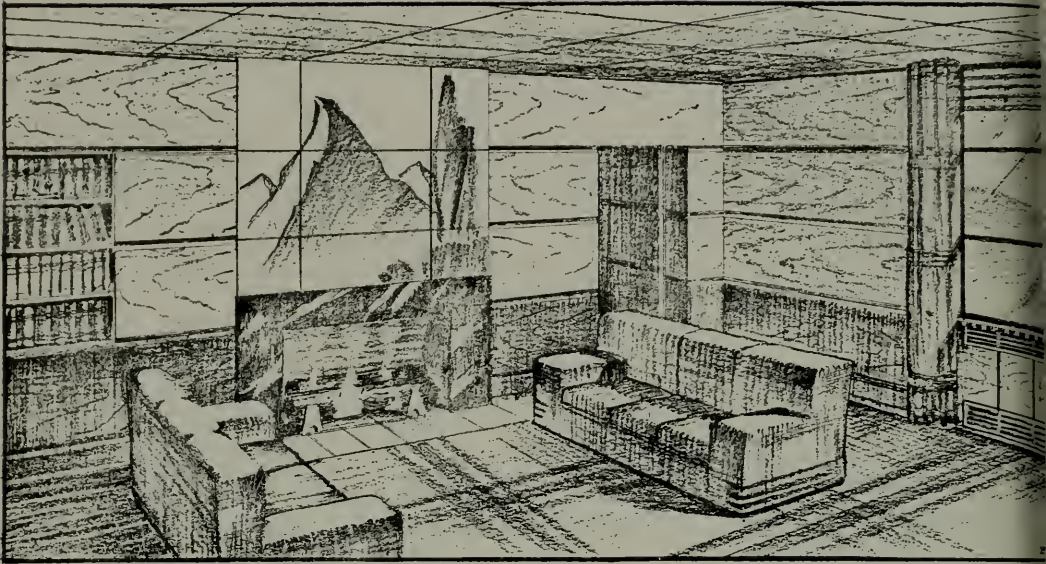

MODERN LIVING ROOM

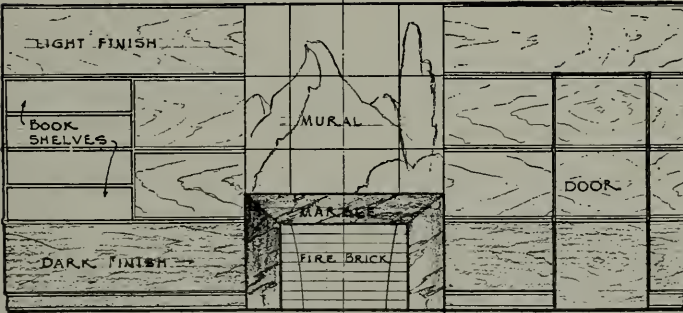

END ELEVATION

SCALE $\frac{1}{4}'' = 1'-0''$

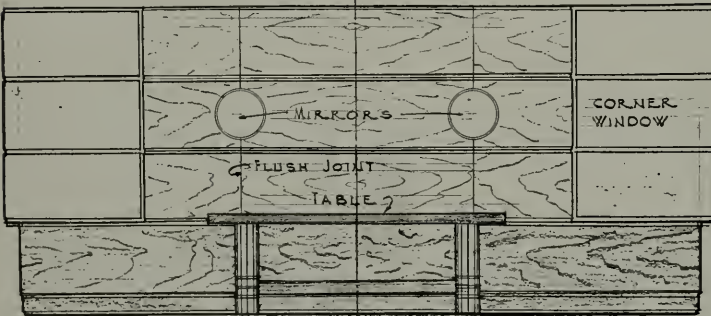

END ELEVATION

SCALE $\frac{1}{4}'' = 1'-0''$

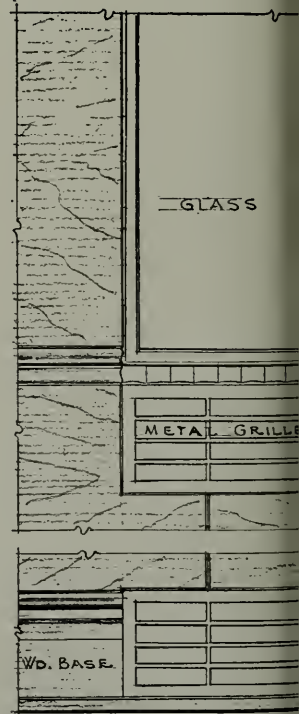

WINDOW DET

SCALE $\frac{1}{2}'' = 1'-0''$

DETAILS

SCALE 1/2 FULL SIZE

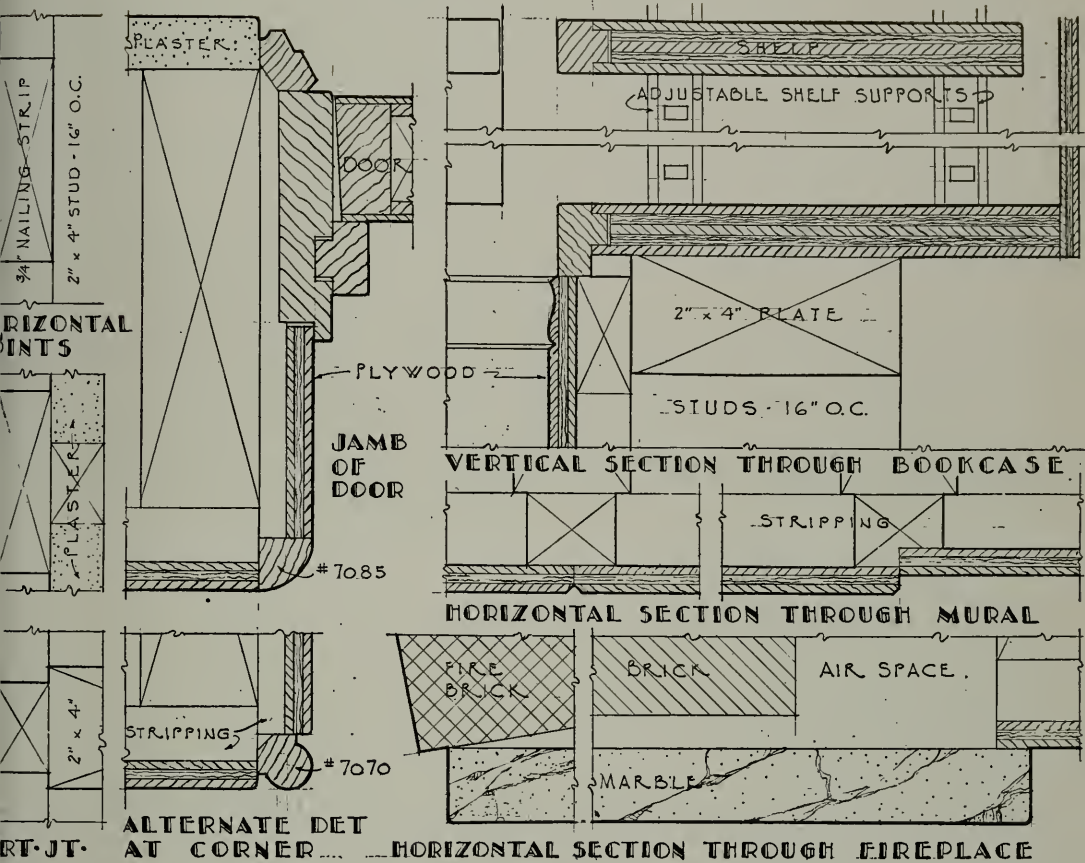

This plate shows the manner in which Douglas Fir plywood may be used in a modern living room where the horizontal motif predominates. Moulded joints carry the horizontal lines across doors, as well as walls. Vertical joints are butted, using a slightly incised V joint. A decorative mural executed in sandblasted plywood is suggested above the mantel. The details show the handling of metal radiator grilles in the dado. Insulation should be placed between the heating element and the plywood.

COLORS

The color scheme in a room of this character calls for a stained finish, either in gray or pale brown color, with the dado finished several shades deeper in tone. The plywood mural can be stained in brighter colors.

MATERIALS

- Wall panels of Douglas Fir Plywood, 1/4" thick in a Good 1-Side Grade or in a Wallboard Grade.
- Book-shelves should be of Sound 2-Sides at least 5/8" thick.
- Numbers in detail drawings refer to the Standard Wood Mouldings, 7000 Series.
- Nailing strips are optional with wood studs, but some architects prefer to use them as a splice under the joints.
- Nails for panels may be 4d finishing or casing.

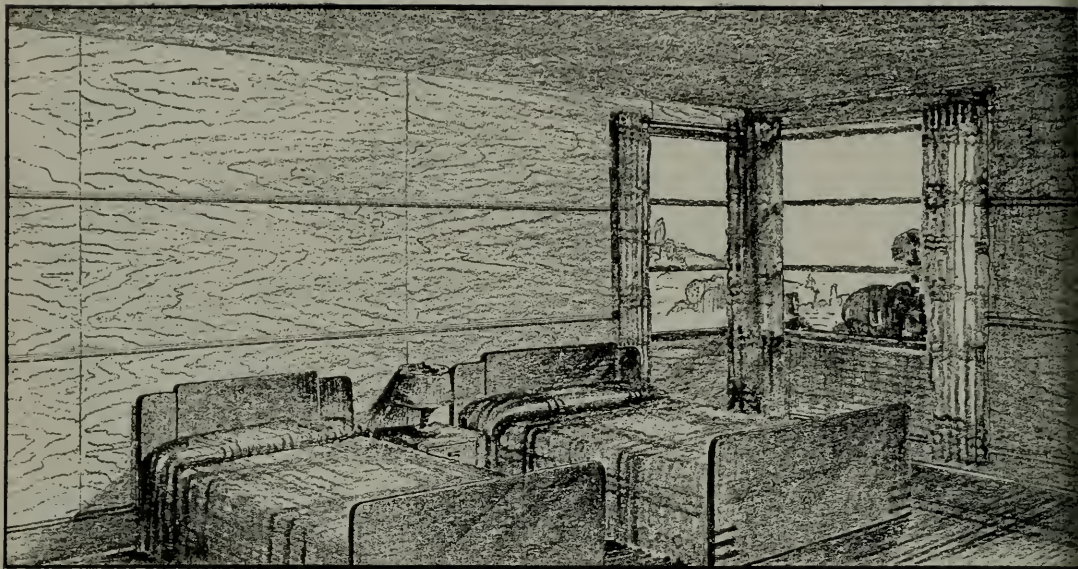

MODERN BED ROOM

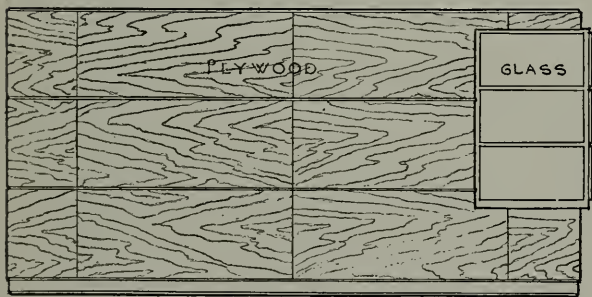

SIDE ELEVATION
SCALE 1/4" = 1'-0"

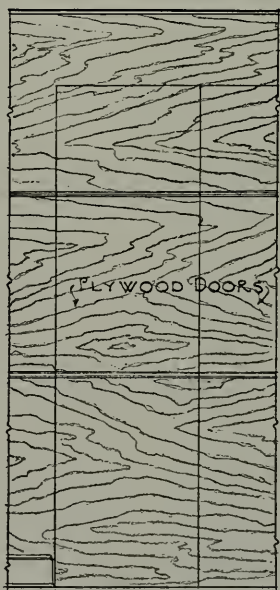

ELEVATION SECTION



END ELEVATION
SCALE 1/4" = 1'-0"

DETAILS OF
CONCEALED CLOSE
SCALE 1/2" = 1'-0"

DETAILS

1/2 FULL SIZE AND 1 1/2" = 1'-0"

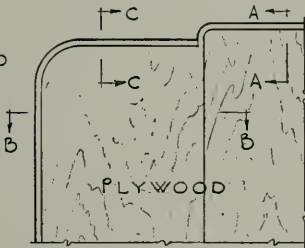
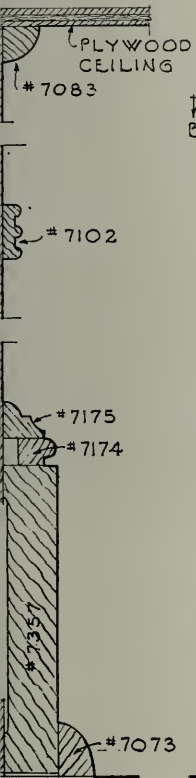

DETAIL AT HEAD OF BED

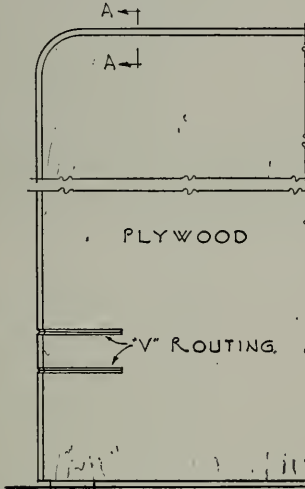

DETAIL AT FOOT OF BED

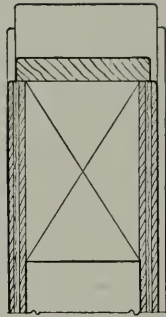

SECTION 'C-C'

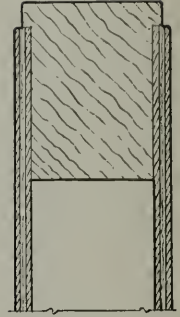

SECTION 'A-A'

SCALE ONE HALF FULL SIZE

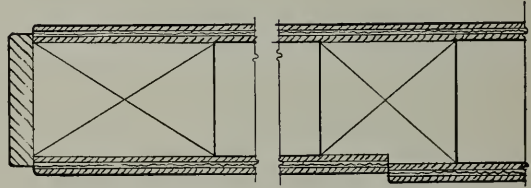

PLAN AT 'B-B'
SCALE 1/2 FULL SIZE

ALL SECTION
SCALE 1/2 FULL SIZE

Expressing the modern trend of design for a bedroom. Both the walls of the room and the furniture are designed for effective use of Douglas Fir plywood. For the room walls, standard lengths and widths of plywood are advantageously employed, with a beaded moulding at the joints to emphasize the horizontal effect. The head boards and foot boards of the beds can be made an integral part of the room design by following the details shown.

COLORS

A warm gray stained effect is suggested as a finish for the woodwork. An alternate finish might be a single priming coat tinted to give desired effect.

MATERIALS

Walls may be of 1/4" Wallboard Grade of Douglas Fir plywood, or of a Good 1-Side Grade, for the highest quality of finish, nailed directly to studs with 4d finishing or casing nails.

Since stock panels are available in even-inch widths from 12 to 32 inches, and also in 36, 42 and 48 inch widths, it will usually be possible to design with, and to utilize, standard widths without cutting.

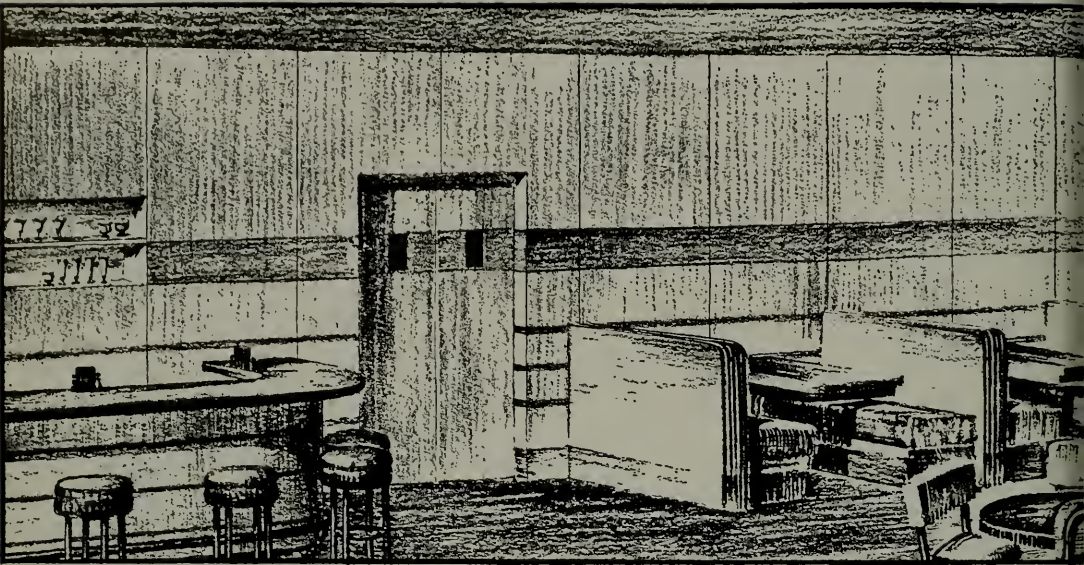

RESTAURANT AND BAR

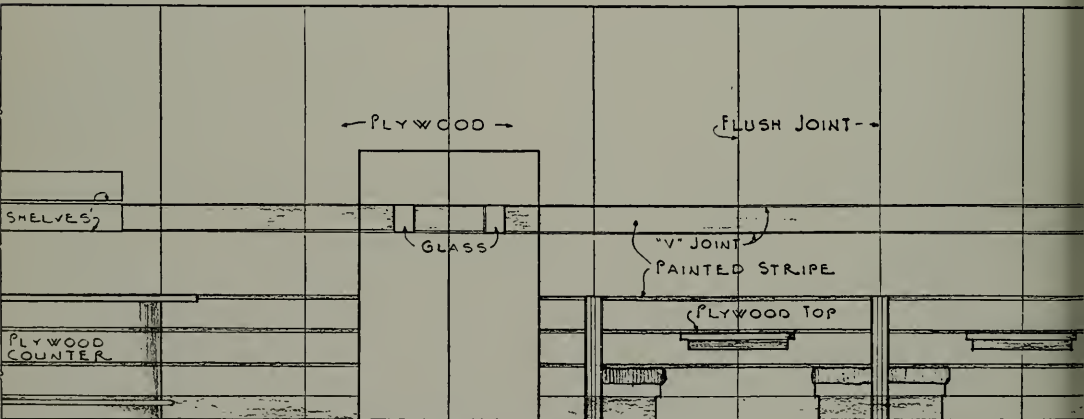

SIDE ELEVATION
SCALE 1/4" = 1'-0"

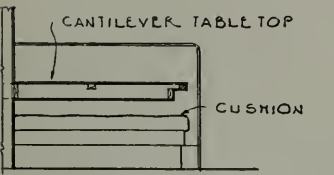

SECT. THROUGH BOOTH
SCALE 1/4" = 1'-0"

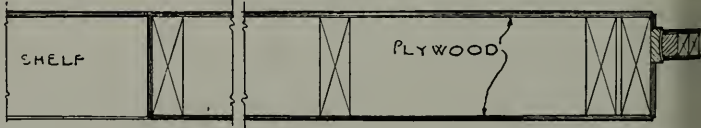

PLAN THROUGH WALL
SCALE 1/2" = 1'-0"

DETAILS

SCALE 1/2 FULL SIZE

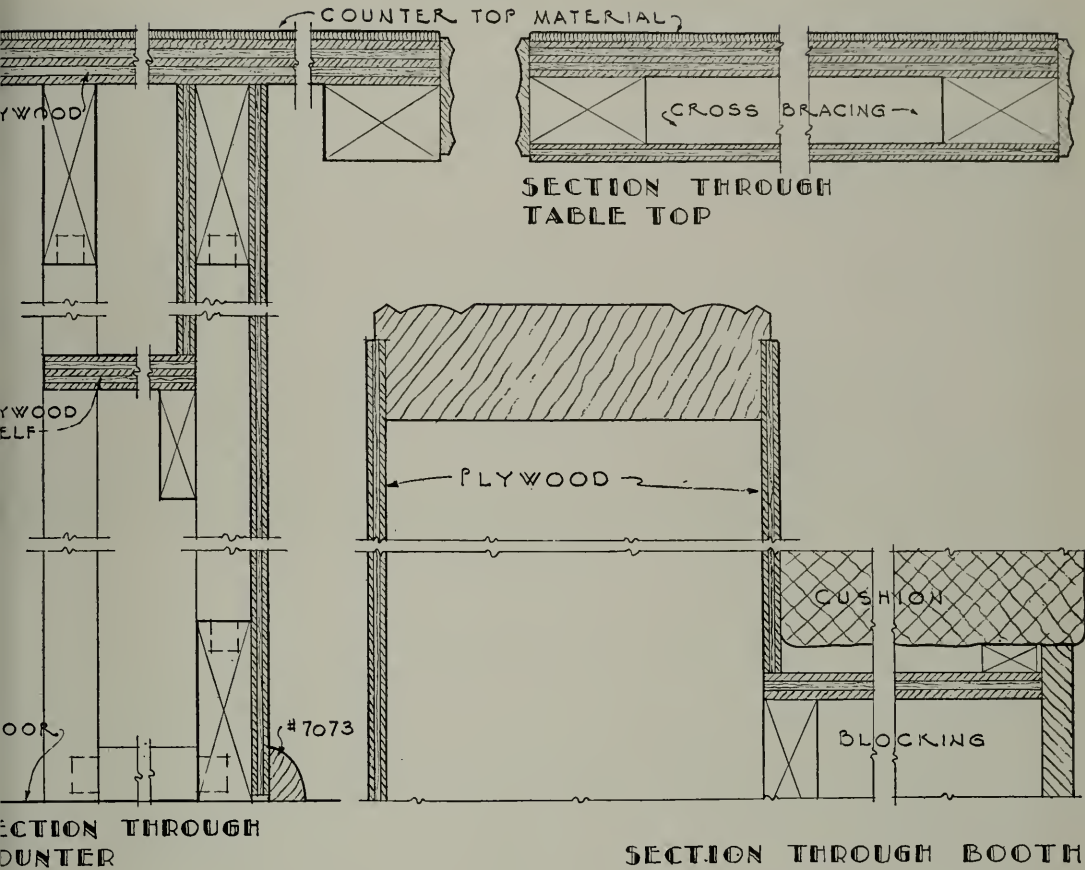

For a semi-formal restaurant and bar, Douglas Fir plywood may be used in various ingenious ways. This drawing shows plywood panels with a combination of flush and V joints. Careful workmanship is required to produce an effective result. The details indicate how plywood may be employed for seats, seat backs, and counter front and top.

COLORS

The plywood surfaces should be painted, with horizontal stripes in contrasting colors, and lined as the judgment may direct with brilliant color. All wood surfaces should be given a dull varnished surface treatment. With this type of design, it is desirable to conceal entirely the grain of the wood.

MATERIALS

Wall panels are of a Wallboard Grade of Douglas Fir plywood, 1/4" thick; stock panels in this grade are available in a 48" width and in 5', 6', 7' and 8' lengths.

Paneling is applied with 4d finishing or casing nails, and puttied.

Seat backs and booth partitions may be of 3/8" or 1/2" panels of Wallboard Grade.

Counter fronts should have grain of face plies running vertically, for ease in bending the 1/4" panels.

Shelving should be 5/8" Sound 2-Sides Grade.

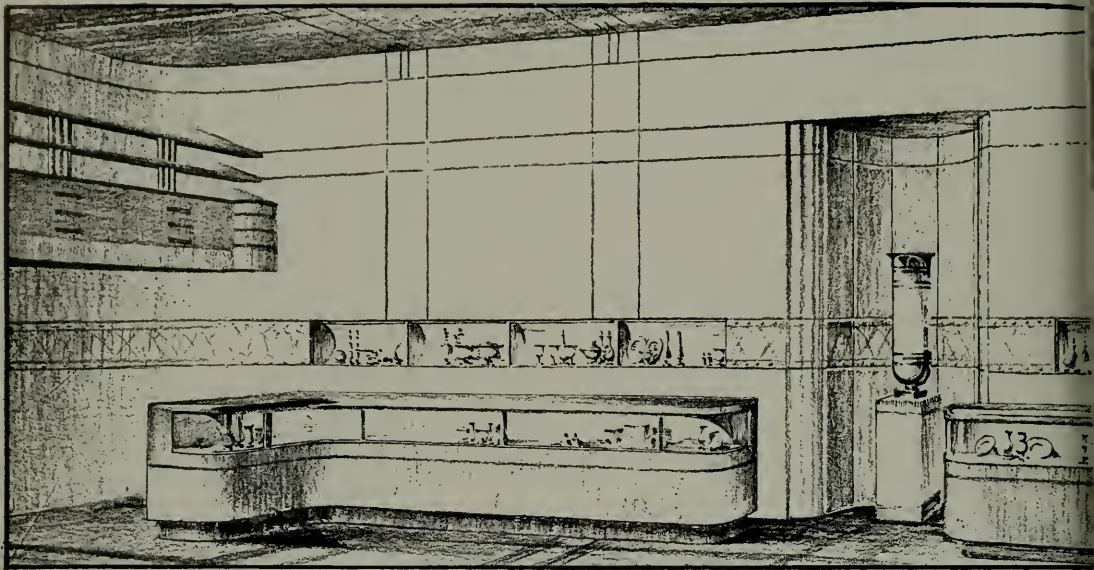

RETAIL DISPLAY ROOM

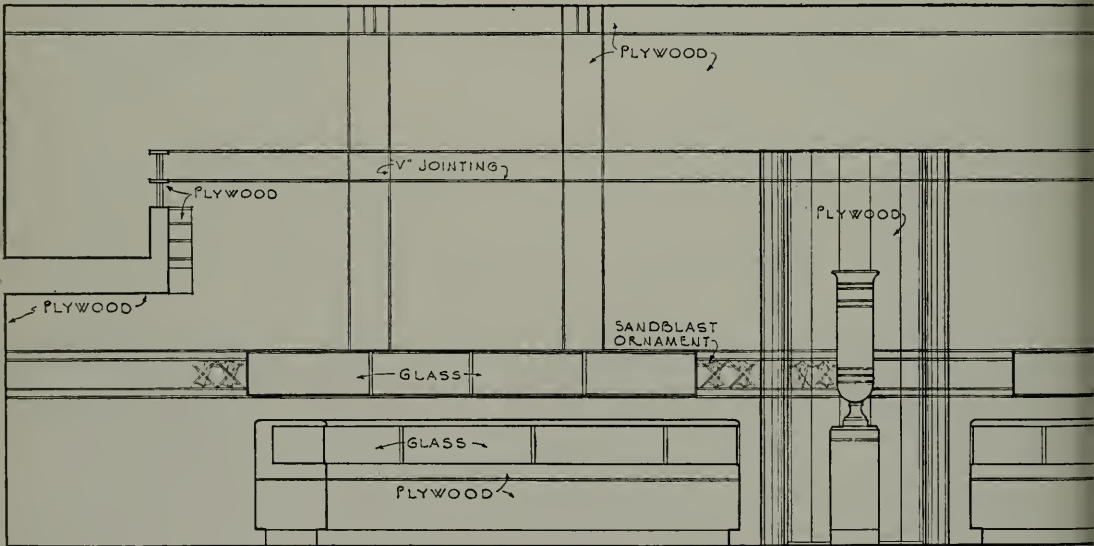

SIDE ELEVATION

SCALE $\frac{1}{4}'' = 1'-0''$

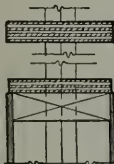

DETAIL OF
BALCONY RAIL
SCALE $1\frac{1}{2}'' = 1'-0''$

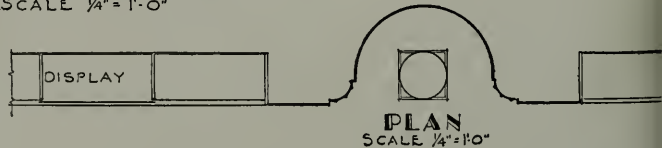

PLAN
SCALE $\frac{1}{4}'' = 1'-0''$

DETAILS

1/2 FULL SIZE AND 1/2" = 1'-0"

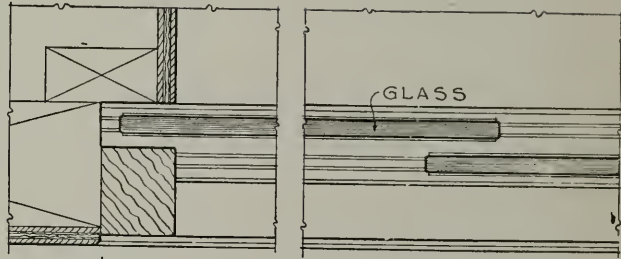
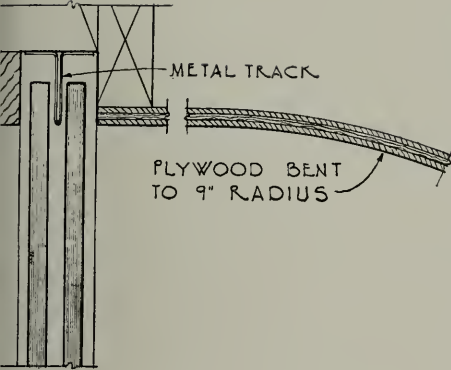

PLAN THROUGH DISPLAY SHELF

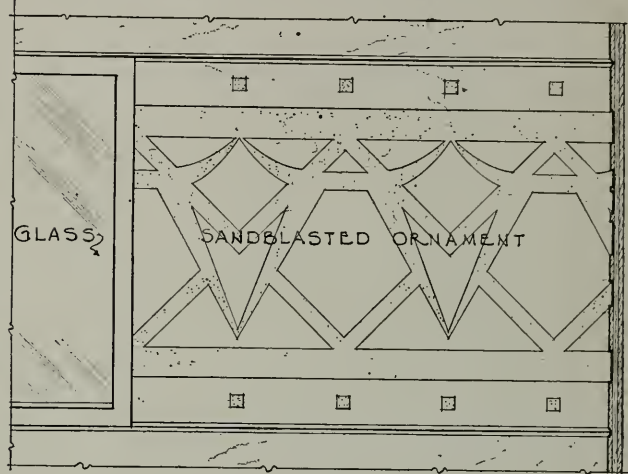
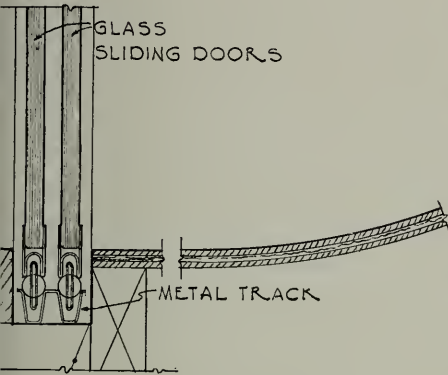

PART ELEVATION OF DISPLAY SHELF AND ORNAMENT

SCALE 1/2" = 1'-0"

A sophisticated modern shop or display room is illustrated here. Douglas Fir plywood is used for walls, balcony, facing, and showcases. This type of design requires careful cabinet work in its execution. The large-radius portions of the semi-circular niche can be faced with strips of plywood, either bent to radius or applied as segments. An ornamental sand-blasted frieze at the height of the recessed wall cases is a feature of the design.

COLORS

The recommended finish would be two coats of paint, in taupe or cafe-au-lait color, applied thinly enough to retain the surface pattern of the underlying wood grain, and slightly stippled.

MATERIALS

The panels should be of a good 1-Side Grade of Douglas Fir plywood, unless the designer elects to cover the grain with paint; in such case 1/4" or 3/8" Wallboard Grade will be adequate. Four penny finishing nails carefully set and puttied are used. The V-jointing at edges of panels is readily accomplished with a plane. Additional scoring of panels is easily done with one of the portable electric saws fitted with a suitable bit.

RESULT OF QUESTIONNAIRE ANENT PUBLIC OPENING OF BIDS

SURVEYING the bidding procedure of architects in private contracts, the Committee on Construction Industry Relations of the American Institute of Architects reports that a large majority of architects do not open bids in the presence of bidders. Some architects, however, believe it desirable to open bids in their presence as a regular practice, according to the committee, of which William Stanley Parker is chairman.

A majority of architects would have no objection to contractors being present at the time the bids are opened, it was found. "But," the report continues, "the fact that a still stronger majority do not permit it indicates that the architects tend to recognize the client's objection, although many replies indicate it is convenience rather than policy that determines the practice. Lack of space in the office for a large gathering or the opening of bids at the client's house or at a committee meeting are cited as reasons."

A second conclusion of the survey, which was conducted at the request of the Associated General Contractors of America, is that notification to bidders of the bids received is not so marked among architects. A very large majority of architects, however, said that they would not object to sending contractors a list of bidders and bids, or posting the list in their offices. A substantial majority of those who now notify prefer mail and oppose open posting in their offices of the bids received.

A bare majority of architects said that they have had requests from contractors to be present at the opening of bids or to be advised as to the names and amounts of the bids received.

The final conclusion is that a strong majority indicate no unwillingness on the part of clients to having bidders present at the opening, which again suggests that convenience rather than policy determines the architect's practice in many cases.

"In general," the report declares, "there are strong opposing convictions expressed as to the desirable policy. Some claim it is the owner's private business and bidders have no rights, and if they were present it might make possible undesirable and embarrassing practices by some of the bidders.

"Others say it is only fair to bidders who have spent time and money on the bid to be present at the opening and some admit the owner prefers to open privately, so as to be able to engage in subsequent negotiations with less embarrassment. These negotiations are not always improper but merely the consideration of personalities and preferences.

"It appears to be falsely assumed by many that the presence of the bidders at the opening means that the owner must make the award immediately. This, of

course, is not true and contractors do not so claim. The owner, having opened the bids, can then take them under advisement. This is all the contractors desire."

Out of 1,200 answers received by the committee in reply to its questionnaire, 357 returns have been analyzed and reported. An added 300 returns have been analyzed which show no significant difference in results. The first 357 returns gave the following response to these six questions:

(1) Do you customarily permit bidders to be present at the opening of bids?

327 answers—Yes, 85; No, 242.

(2) If not, do you customarily notify bidders of the bids received?

(a) By mail—235 answers—Yes, 141; No, 95.

(b) By posting in office—151 answers—
Yes, 54; No, 97.

(3) Have you had any requests from contractors for permission to be present at the opening of bids or to be advised as to the names and amounts of bids received?

305 answers—Yes, 161; No, 144.

(4) Have you any objections to permitting bidders to be present at the opening of bids?

325 answers—Yes, 126; No, 199.

(5) Have you any objection to sending bidders, or posting in your office for general information, the list of bidders and bids received?

304 answers—Yes, 61; No, 243.

(6) Has any client indicated to you that he was willing to have the bidders present at the opening of bids?

331 answers—Yes, 140; No, 191.

Because some of the returns showed the possibility of sectional differences of custom and opinion, the second group of 300 returns were geographically analyzed as to the answers to questions 1, 4 and 6.

"This developed rather marked differences that offer food for thought," the report points out. "In the northeastern section of the country, a much smaller percentage of the architects permit bidders to be present at the opening of bids, but a larger percentage have definite objections to doing so. Yet they report fewer cases of unwillingness on the part of the client. In the south and west, in spite of a larger indication of client objection, there appears to be less objection by the architects and a markedly higher percentage that permits bidders to be present.

"Does this suggest that in the northeast we are more subservient to our clients' wishes while in the south and west architects are more ruggedly individual? Perhaps it would be wise to await a broader foundation of evidence before building any final conclusion in this regard."

ARCHITECTS' BULLETIN

Issued For

THE STATE ASSOCIATION OF CALIFORNIA ARCHITECTS

Northern Section

STATE ASSOCIATION MEMBER
OF THE
AMERICAN INSTITUTE OF ARCHITECTS

Editor

Harris C. Allen

Address all communications for publication
in the Bulletin to the Editor (Harris C.
Allen) 557 Market Street, Room 218, San
Francisco, California.

Board of Control

Harris C. Allen Otto G. Hintermann
Harry Michelsen Ellsworth E. Johnson
Chester H. Miller

State Association Officers

Harry M. Michelsen, San Francisco, President
George D. Riddle, Los Angeles, Vice-Pres.
Louis N. Crawford, Santa Maria, Secretary
Otto G. Hintermann, San Francisco, Treas.

Regional Director, A. I. A.

Albert J. Evers, San Francisco

Representative of Regional Director, Southern California

Gordon B. Kaufmann, Los Angeles

Executive Board—Northern Section

Officers

Harry M. Michelsen.....President
Gwynn OfficerVice-President
Ellsworth E. Johnson.....Secretary
Otto G. Hintermann.....Treasurer

Directors

Walter E. Baumberger William G. Merchant
Harry J. Devine Frederick H. Reimers

Executive Board—Southern Section

Officers

George D. Riddle.....President
Gordon B. Kaufmann.....Vice-President
Louis N. Crawford.....Secretary
Robert H. Orr.....Treasurer

Directors

Harold C. Chambers Lester G. Hibbard
A. M. Edelman W. P. Lodge

S. B. Marston

Advisors—Northern Section

Harris C. Allen Edward R. French, Jr.
G. F. Ashley Arthur F. Dodman
J. K. Ballantine Joseph Losekann
Wayne S. Hertzka David H. Horn
Conrad T. Kett Robert Stanton
W. I. Garren Charles S. McKenzie
W. G. Merchant Henry C. Collins
Thomas E. Pring Leo J. Sharps
Vincent Raney Carl F. Gromme
F. H. Reimers C. C. Dakin
Edward O. Blodgett F. T. Georgeson
George P. Simonds Ralph D. Taylor
Gwynn Officer

1938 CONVENTION OCT. 13-15

PREPARATIONS continue for the gathering at the Fairmont Hotel in San Francisco, October 13-14-15, and there is no doubt that it will be an outstanding one for business and pleasure, and probably for attendance. The committee personnel for the Northern Section is as follows:

ADVISORY COMMITTEE

J. K. Ballantine, Chairman
Harris Allen
William I. Garren
Otto G. Hintermann
Roland I. Stringham
Harry M. Michelsen, Honorary
Ellsworth E. Johnson, Honorary

ENTERTAINMENT

Harris C. Allen, Chairman
Ernest E. Weihe
C. Jefferson Sly
Clarence W. Mayhew
W. A. Talley

RESOLUTIONS

Gwynn Officer
Henry C. Collins
Conrad F. T. Kett

BUSINESS PROGRAM COMMITTEE

Vincent Raney, Chairman
William I. Garren
Frederick H. Reimers
Wayne Hertzka
Richard Stephens
Clark Wayland, Honorary
Wm. Hague, Honorary

PUBLICITY

Ellsworth E. Johnson, Chairman
Otto G. Hintermann
John Davis Young
Wm. Mooser
Geo. P. Simonds

FINANCE

Otto G. Hintermann, Treasurer

GOLF

John J. Donovan

REGISTRATION AND RECEPTION

Lester W. Hurd, Chairman
Chester H. Miller
Chas. H. Sawyer
John J. Donovan

GOLDEN GATE EXHIBITION

Wm. G. Merchant, Chairman
Edward L. Frick
Timothy L. Pflueger

Ernest Weihe has consented to act as Director of the Pageant to be presented at the Convention Banquet on Friday, October 14th, and with his past record as chairman of the Bohemian Club Jinks Committee and for a number of years in charge of their stage scenic effects, an extremely interesting and artistic production may be expected. While not so large or elaborate as the pageants which the New York Architectural League used to present, something of a similar nature is proposed.

1938-9 ADVISORS

The San Francisco District (San Francisco Society of Architects) has elected as advisors: Frederick H. Reimers (president), J. K. Ballantine (secretary), Harris C. Allen, Wm. Merchant, Ernest E. Weihe, Albert R. Williams, Dodge A. Riedy, Harold H. Weeks, Jas. F. McGuinness, Samuel Lightner Hyman.

The North Bay District elected C. A. Caulkins, Jr.

The Lower San Joaquin District (Stockton) has elected Peter Sala advisor and J. U. Cloudsley, secretary; Santa Clara Valley's new advisor is Edw. W. Kress; San Mateo advisor, Mario Corbett. The East Bay held a dinner for the election on the 2nd of September and several of the other districts are yet to be heard from.

F. H. A. MEETINGS

A series of conferences were conducted in San Francisco early this month by Eugene H. Klaber, Associate Director F.H.A. Rental Housing Division. The meetings were for architects only and dealt with new technique and principles underlying the planning of large scale housing projects. Mr. Klaber, a past president of the Chicago Chapter of the Institute, is, perhaps, the best qualified man in this country to deal with this subject. A review of these conferences will be given in a latter issue of the Bulletin.

MINIMUM FEES

The approved schedule of fees, as noted last month, is now in the Association office, and is available to all members. In this connection, let us again emphasize that it is not the ethics (which is the concern directly of the Institute, not the State Association) but sound common sense and good business that we should maintain this established minimum fee standard, rather than cut our own throats by cutting fees. No matter how profitable a special case may appear, in the long run no individual is profited by a policy of fee-cutting, and the amount of architectural service required for adequate completion of a job just cannot be done for much less than these minimum standards—unless the architect is prepared to lose money or to give his own time for nothing. This is an old story, but bears repeating.

POST OFFICE DESIGN WINNERS

Winners of the ten \$1,000 awards in the U. S. Treasury Department architectural design competition for post office buildings, costing approximately \$50,000 each, have been announced by Secretary Morgenthau as follows:

Arthur F. Deam, Saugatuck, Mich.; Theodore Fletcher, Wilmington, Del.; Carl F. Guenther, Cleveland, Ohio, two designs; John E. Miller, Cleveland, Ohio; T. Marshall Rainey, Cincinnati, Ohio; Francis W. Roudebush, New York; Harvey Stevenson and Eastman Studs, New York; and Theo. Ballow White, Philadelphia, Pa.

In addition to the two designs by Guenther, the jury of awards also chose another design submitted by

Miller and Guenther. All designs remained anonymous until judged.

Selection of the winning designs was made by a jury of famed architects which included Charles Z. Klauder and Paul P. Cret, Philadelphia; Aymar Embury, II, and Gilmore D. Clarke, New York; Philip B. Maher, Chicago; Henry R. Shepley, Boston; Richard J. Neutra, Los Angeles; and Edward Bruce, Washington, D. C. Louis A. Simon, supervising architect of the Treasury Department, was adviser.

In addition to choosing ten prize-winning designs, the jury voted honorable mention to the following:

Salvatore Grillo, New York; Hubert Ripley and A. B. Le Boutillier, New York; Eldredge Snyder, New York; Samuel A. Marks, Chicago; Frank Wehrle, New York; Clarence O. Morrison, Brooklyn, N. Y.; John T. Haneman, New York; M. Righton Swicegood, New York, two designs; Edward D. Stone and Morris Ketchum, New York, and Hays, Simpson and Hunsicker, Cleveland, Ohio.

POTTERY AND CERAMIC SCULPTURE

One hundred pieces of pottery and ceramic sculpture will be shown by invitation at the Golden Gate International Exposition next year. The exhibit will be chosen by a Jury of Award at the seventh annual Robineau Memorial National Ceramic Exhibition to be held in the Syracuse Museum of Fine Arts, opening October 27 and continuing through November 20.

All works to be shown must be received on or before October 15 at the Syracuse Museum of Fine Arts, Syracuse, N. Y. For the first time, Canadian ceramists have been invited to participate in the exhibition.

HEADS DUNNE PAINT COMPANY

William L. Turner, for 23 years with the Bass-Heuter Paint Company and for 15 years manager of the East Bay Division of the Bass-Heuter and National Lead Companies, has been chosen president and general manager of the Frank W. Dunne Company, 41st and Linden Streets, Oakland, makers of good paint.

GYMNASIUM AND AUDITORIUM

Preliminary drawings are being made by Thomas M. Edwards, 9 Geary Street, San Francisco, for a frame and stucco gymnasium and auditorium, the latter of reinforced concrete, for the Half Moon Bay High School District to cost \$150,000.

NEW FEDERAL BUILDING

The Federal Government has authorized immediate construction of a parcel-post building on Howard Street, near Seventh, San Francisco, at a cost of \$500,000. The building will be five stories.

Estimator's Guide

Giving Cost of Building Materials, Wage Scale, Etc.

Amounts given are figuring prices and are made up from average quotations furnished by material houses to San Francisco contractors. 3% Sales Tax on all materials but not labor.

All prices and wages quoted are for San Francisco and the Bay District. There may be slight fluctuation of prices in the interior and southern part of the state. Freight cartage, at least, must be added in figuring country work.

3and—1½% amount of contract.

Brickwork—

Common, \$40 to \$45 per 1000 laid, (according to class of work).
 Face, \$100 to \$110 per 1000 laid, (according to class of work).
 Brick Steps, using pressed brick, \$1.25 lin. ft.
 Brick Veneer on frame buildings, \$.75 sq. ft.
 Common f.o.b. cars, \$14.00 at yard. Cartage extra.
 Face, f.o.b. cars, \$45.00 to \$50.00 per 1000, carload lots.

HOLLOW TILE FIREPROOFING (f.o.b. job)

3x12x12 in. \$ 84.00 per M
 4x12x12 in. 94.50 per M
 6x12x12 in. 126.00 per M
 8x12x12 in. 225.00 per M

HOLLOW BUILDING TILE (f.o.b. job)

carload lots.
 8x12x5½ \$ 94.50
 6x12x5½ 73.50

Building Paper—

1 ply per 1000 ft. roll \$3.50
 2 ply per 1000 ft. roll 5.00
 3 ply per 1000 ft. roll 6.25
 Brownskin, 500 ft. roll 4.50
 Brownskin, Pro-tect-o-mat, 1000 ft. roll 9.00
 Sisakraft, 500 ft. roll 5.00
 Sash cord com. No. 7 \$1.20 per 100 ft.
 Sash cord com. No. 8 1.50 per 100 ft.
 Sash cord spot No. 7 1.90 per 100 ft.
 Sash cord spot No. 8 2.25 per 100 ft.
 Sash weights cast iron, 500.00 ton.
 Nails, \$3.50 base.
 Sash weights, \$45 per ton.

Concrete Work (material at San Francisco bunkers)—Quotations below 2000 lbs. to the ton. \$2.00 delivered.

No. 3 rock, at bunkers.....\$1.45 per ton
 No. 4 rock, at bunkers..... 1.45 per ton
 Elliott top gravel, at bunkers 2.10 per ton
 Washed gravel, at bunkers.... 1.45 per ton
 Elliott top gravel, at bunkers 2.10 per ton
 City gravel, at bunkers..... 1.45 per ton
 River sand, at bunkers..... 1.40 per ton
 Delivered bank sand..... 1.00 cu. yd.

Note—Above prices are subject to discount of 2% per ton on invoices paid on or before the 10th of month, following delivery.

SAND

Del Monte, \$1.75 to \$3.00 per ton.
 Fan Shell Beach (car lots, f.o.b. Lake Majella), \$.75 to \$4.00 per ton.

Cement (paper sacks) \$3.00 bbl., warehouse or delivery.

Car-load lots delivered \$2.70, f.o.b. cars \$2.52
 (Cloth sacks) \$3.00 bbl..

Rebate 10 cents bbl. cash in 15 days.
 Atlas White } 1 to 100 sacks, \$1.50 sack,
 Calaveras White } warehouse or delivery; over 100
 Medusa White } sacks, \$1.25; 2% discount 10th
 (of month).

Forms, Labors average \$40.00 per M.
 Average cost of concrete in place, exclusive of forms, 35c per cu. ft.;
 with forms, 60c.

4-inch concrete basement floor
 12½c to 14c per sq. ft.

Rat-proofing 7½c
 Concrete Steps \$1.25 per lin. ft.

Dampproofing and Waterproofing—

Two-coat work, 20c per yard.
 Membrane waterproofing—4 layers of saturated felt, \$4.50 per square.
 Hot coating work, \$1.80 per square.
 Medusa Waterproofing, 15c per lb., San Francisco Warehouse.
 Tricocel waterproofing.

Electric Wiring—\$12.00 to \$15.00 per outlet for conduit work (including switches).
 Knob and tube average \$3.50 per outlet.

Elevators—

Prices vary according to capacity, speed and type. Consult elevator companies.
 Average cost of installing an automatic elevator in four-story building, \$2800;
 direct automatic, about \$2700.

Excavation—

Sand, 60 cents; clay or shale \$1 per yard.
 Trucks, \$12.00 per day.
 Trucks, \$22 to \$27.50 per day.

Above figures are an average without water. Steam shovel work in large quantities, less; hard material, such as rock, will run considerably more.

Fire Escapes—

Ten-foot galvanized iron balcony, with stairs, \$115 installed on new buildings; \$140 on old buildings.

Floors—

Composition Floors—22c to 40c per sq. ft.
 In large quantities, 16c per sq. ft. laid.
Mosaic Floors—80c per sq. ft.
Duraflex Floor—23c to 30c sq. ft.
Rubber Tile—50c to 75c per sq. ft.
Terazzo Floors—45c to 60c per sq. ft.
Terazzo Steps—\$1.60 lin. ft.

Hardwood Flooring (delivered to building)—

3½x2¼" T & G Maple \$ 88.00 M ft.
 1½x2¼" T & G Maple 115.00 M ft.
 7/8x3½" sq. edge Maple 100.00 M ft.

	1½x2¼"	¾x2"	¾x2"
	T & G	T & G	Sq. Ed.
Clr. Old. Oak	\$120.00 M	\$ 82.50 M	\$110 M
Sel. Old. Oak	99.00 M	69.50 M	84 M
Clr. Pla. Oak	106.00 M	74.50 M	86 M
Sel. Pla. Oak	97.00 M	62.50 M	76 M
Clear Maple	111.00 M	100.00 M	
Laying & Finishing	14c ft.	12c ft.	10c ft.
Wage—Floor layers,	\$10.00.		

Note—Above quotations are all board measure except last column which is sq. ft.

Glass (consult with manufacturers)—

Double strength window glass, 20c per square foot.
 Plate 75c per square foot (unglazed) in glass, \$1.00.

Art, \$1.00 up per square foot.
 Wire (for skylights), 40c per sq. foot.
 Obscure glass, 30c square foot.

Glass bricks, \$2.40 per sq. ft., in place.
Note—If not stipulated add extra for setting.

Heating—

Average, \$1.90 per sq. ft. of radiation according to conditions.
 Warm air (gravity) average \$40 per register.
 Forced air, average \$60 per register.

Iron—Cost of ornamental iron, cast iron, etc., depends on designs.

Lumber (prices delivered to bldg. site).

No. 1 common \$29.00 per M
 No. 2 common 27.00 per M
 Select O. P. common 34.00 per M
 2x4 No. 3 form lumber 24.00 per M
 1x4 No. 2 flooring VG 55.00 per M
 1x4 No. 3 flooring VG 47.00 per M
 1x6 No. 2 flooring VG 60.00 per M
 1½x4 and 6, No. 2 flooring 60.00 per M

Slash grain—

1x4 No. 2 flooring \$43.00 per M
 1x4 No. 3 flooring 40.00 per M
 No. 1 common run T. & G. 30.00 per M
 Lath 5.25 per M

Shingles (add cartage to price quoted)—

Redwood, No. 1 \$1.10 per bdle.
 Redwood, No. 290 per bdle.
 Red Cedar 1.10 per bdle.

Millwork—Standard.

O. P. \$85.00 per 1000. R. W., \$90.00 per 1000 (delivered).

Double hung box window frames, average with trim, \$6.50 and up, each.

Doors, including trim (single panel, 1¾ in. Oregon pine) \$8.00 and up, each.

Doors, including trim (five panel, 1¾ in. Oregon pine) \$6.00 each.

Screen doors, \$3.50 each.
 Patent screen windows, 25c a sq. ft.

Cases for kitchen pantries seven ft. high per lineal ft., \$8.00 each.

Dining room cases, \$8.00 per lineal foot.
 Rough end finish about 75c per sq. ft.

Labor—Rough carpentry, warehouse heavy framing (average), \$17.50 per M.

For smaller work average, \$35.00 to \$45.00 per 1000.

Marble—(See Dealers)

Painting—

Two-coat work	36c per yard
Three-coat work	50c per yard
Cold Water Painting	10c per yard
Whitewashing	4c per yard
Turpentine, 65c per gal., in 5 gal. cans, and 55c per gal. in drums.	
Raw Linseed Oil—97c gal. in bbls.	
Boiled Linseed Oil—\$1.00 gal. in bbls.	
Medusa Portland Cement Paint, 20c per lb.	

Pioneer or Dutch Boy White Lead in Oil (in steel kegs).

1 ton lots, 100 lbs. net weight	10 1/4c
500 lbs. and less than 1 ton lots	10 1/2c
Less than 500 lb. lots	11c

Pioneer or Dutch Boy Red Lead and Litharge (in steel kegs).

1 ton lots, 100 lb. kegs, net weight	10 1/4c
500 lbs. and less than 1 ton lots	10 1/2c
Less than 500 lb. lots	11c

Pioneer Red Lead in Oil (in steel kegs)

1 ton lots, 100 lb. kegs, net weight	11 1/4c
500 lbs. and less than 1 ton lots	11 1/2c
Less than 500 lb. lots	12c

Note—Accessibility and conditions cause some variance in costs.

Patent Chimneys—

6-inch	\$1.25 lineal foot
8-inch	1.75 lineal foot
10-inch	2.25 lineal foot
12-inch	3.00 lineal foot

Plastering—Interior—

1 coat, brown mortar only, wood lath	Yard \$0.75
2 coats, lime mortar hard finish, wood lath80
2 coats, hard wall plaster, wood lath85

3 coats, metal lath and plaster	1.30
Keene cement on metal lath	1.30
Ceilings with 3/4 hot roll channels metal lath75
Ceilings with 3/4 hot roll channels metal lath plastered85
Single partition 3/4 channel lath 1 side	1.50
Single partition 3/4 channel lath 2 sides 2 inches thick	1.50
4-inch double partition 3/4 channel lath 2 sides	1.30
4-inch double partition 3/4 channel lath 2 sides plastered	3.00

Plastering—Exterior—

2 coats cement finish, brick or concrete wall	\$1.00
2 coats Calaveras cement, brick or concrete wall	1.35
3 coats cement finish, No. 18 gauge wire mesh	1.50
3 coats Calaveras finish, No. 18 gauge wire mesh	1.75

Wood lath, \$7.50 to \$8.00 per 1000.	
2.5-lb. metal lath (dipped)17
2.5-lb. metal lath (galvanized)20
3.4-lb. metal lath (dipped)22
3.4-lb. metal lath (galvanized)28
3/4-inch hot roll channels, \$72 per ton.	
Finish plaster, \$18.90 ton in paper sacks.	
Dealer's commission, \$1.00 off above quotations, \$13.85 (rebate 10c sack).	
Lime, 1 c. b. warehouse \$2.25 bbl.; cars, \$2.15	
Lime, bulk (ton 2000 lbs.), \$16.00 ton.	
Wall Board 5 ply, \$50.00 per M.	
Hydrate Lime, \$19.50 ton.	

Plasterers Wage Scale	\$1.25 per hour
Lathers Wage Scale	1.25 per hour
Hot Carriers Wage Scale	1.10 per hour
Composition Stucco—\$1.80 to \$2.00 sq. yard (applied).	

Plumbing—

From \$70.00 per fixture up, according to grade, quantity and runs.

Roofing—

"Standard" tar and gravel, \$6.50 per sq. for 30 sqs. or over.
Less than 30 sqs. \$7.00 per sq.
Tile, \$20.00 to \$35.00 per square.
Redwood Shingles, \$7.50 per square in place.
Copper, \$16.50 to \$18.00 per sq. in place.

Cedar Shingles, \$8.00 per sq. in place.
Recoat, with Gravel, \$3.00 per sq.
Asbestos Shingles, \$15 to \$25 per sq. laid.
Slate, from \$25.00 to \$60.00 per sq. laid according to color and thickness.

Sheet Metal—

Windows—Metal, \$1.75 a sq. foot.
Fire doors (average), including hardware \$1.75 per sq. ft.

Skylights—(not glazed)

Copper, 90c sq. ft. (flat).
Galvanized iron, 30c sq. ft. (flat).
Vented hip skylights 60c sq. ft.

Steel—Structural

\$120 ton (erected), this quotation is an average for comparatively small quantities. Light truss work higher. Plain beams and column work in large quantities \$90 to \$100 per ton.

Steel Reinforcing—

\$80.00 to \$120.00 per ton, set.

Stone—

Granite, average, \$6.50 cu. foot in place.
Sandstone, average Blue, \$4.00, Boise \$3.00 sq. ft. in place.
Indiana Limestone, \$2.80 per sq. ft. in place.

Store Fronts—

Copper sash bars for store fronts, corner center and around sides, will average 75c per lineal foot.
Note—Consult with agents.

Tile—Floor, Wainscot, etc.—(See Dealers)
Asphalt Tile—18c to 28c per sq. ft. installed.

Venetian Blinds—

40c per square foot and up. Installation extra.

THE BUILDERS' EXCHANGE OF SAN FRANCISCO STANDARD WAGE SCALE

For mechanics employed on construction work in the Bay Region. Effective September 1, 1937

CRAFT	Journeymen Mechanics
Asbestos Workers	\$ 8.00
Bricklayers (8h-5d)	10.50
Bricklayers' Hodcarriers (6h-5d)	6.75
Cabinet Workers (Outside) (5d)	8.00
Caisson Workers (Open)	6.40
Carpenters (8h-5d)	10.00
Cement Finishers (8h-5d)	10.00
Cork Insulation Workers (8h-5d)	9.00
Electric Workers (8h-5d)	11.00
Electrical Fixture Hangers	8.00
Elevator Constructors	10.40
Engineers, Portable & Hoisting	9.00
Glass Workers (8h-5d)	9.48
Hardwood Floormen	9.00
Housesmiths, Architectural Iron (Shop) (8h-5d)	9.00
Housesmiths, Architectural Iron (Outside) (8h-5d)	10.00
Housesmiths, Reinforced Concrete or Rodmen (8h-5d)	10.00
Iron Workers (Bridge and Structural) Including Engineers (8h-5d)	12.00

CRAFT	Journeymen Mechanics
Laborers, Building (8h-5d)	\$ 6.00
Laborers, Common (8h-5d)	6.00
Lathers, Channel Iron (6h-5d)	9.00
Lathers, Others	9.00
Marble Setters (8h-5d)	10.50
Marble Setters' Helpers (8h-5d)	5.50
Millwrights	9.00
Model Makers (\$1.50 per hr-6h)	9.00
Modelers (\$2 per hr-6h)	12.00
Model Casters	7.20
Mosaic and Terrazzo Workers (Outside)	9.00
Painters (7h-5d)	8.50
Painters, Varnishers and Polishers (Outside)	9.00
Pile Drivers and Wharf Builders	9.00
File Workers' Engineers	10.00
Plasterers (6h-5d)	10.00
Plasterers' Hodcarriers (6h-5d)	7.50
Plumbers (8h-5d)	11.00
Roofers, Composition (8h-5d)	9.00
Roofers, All Others (8h-5d)	8.00
Sheet Metal Workers (8h-5d)	10.00
Sprinkler Fitters	10.00

CRAFT	Journeymen Mechanics
Steam Fitters (8h-5d)	\$11.00
Stair Builders (8h-5d)	9.00
Stone Cutters, Soft and Granite (8h-5d)	8.00
Stone Setters, Soft and Granite	12.00
Stone Derricks	9.00
Tile Setters (8h-5d)	11.00
Tile Setters' Helpers (8h-5d)	6.50
Tile, Cork and Rubber (8h-5d)	9.00
Welders, Structural Steel Frame on Buildings 11.00	
Welders, All Others on Buildings	9.00
Dump Truck Drivers, 2 yards or less	6.00
Dump Truck Drivers, 3 yards	6.50
Dump Truck Drivers, 4 yards	7.00
Dump Truck Drivers, 5 yards	7.00
Dump Truck Drivers, 6 yards	7.50
Truck Drivers of Concrete Mixer Trucks: 2 yards or less	6.50
3 yards	7.00
4 yards	7.50
5 yards	7.50
6 yards	8.00

GENERAL WORKING CONDITIONS

- Eight hours shall constitute a day's work for all crafts except as otherwise noted.
- Plasterers' Hodcarriers, Bricklayers' Hodcarriers, Roofers' Laborers, and Engineers, Portable and Hoisting, shall start 15 minutes before other workmen, both at morning and at noon.
- Five days, consisting of not more than eight hours a day, on Monday to Friday inclusive, shall constitute a week's work.
- Transportation costs in excess of twenty-five cents each way shall be paid by the contractor.
- Overtime shall be paid as follows: For the first four hours after the first eight hours, time and one-half. All time thereafter shall be paid

- double time, Saturdays (except Laborers), Sundays and holidays, from 12 midnight of the preceding day, shall be paid double time.
- On Saturday, Laborers shall be paid straight time to an eight-hour day.
- Where two shifts are worked in any twenty-four hours, shift time shall be straight time. Where three shifts are worked, eight hour's pay shall be paid for seven hours on the second and third shifts, allowing one-half hour for lunch.
- All work, except as noted in paragraph 9, shall be performed between the hours of 8 a.m. and 5 p.m.
- In emergencies, or where premises cannot be vacated until the close of business, men then

- reporting for work shall work at straight time. Any work performed on such jobs after midnight shall be paid time and one-half up to four hours of overtime and double time thereafter, provided, that if a new crew is employed on Saturdays, Sundays or holidays which has not worked during the five preceding days, such crew shall be paid time and one-half.
- Recognized holidays to be: New Year's Day, Decoration Day, Fourth of July, Labor Day, Admission Day, Thanksgiving Day, Christmas Day.
- Men ordered to report for work, for whom no employment is provided, shall be entitled to two hours' pay.

MODERNIZED PRODUCTS

Brief Notes on New Materials and Equipment in the Building Industry.

94-94A. PLUMBING EQUIPMENT

Crane Company have brought out two new booklets illustrating their gas fired air conditioner and some of their new plumbing equipment for the modest cost home. Both booklets appear to be very interesting and worth while. Send the coupon for your copies.

95. PLASTIC PAINT

The I. F. Lauks Company have issued a folder which tells the story of one of their new products, a plastic paint which gives a stucco-like finish for interiors. This coupon will bring you a copy.

96. WINDOW CONDITIONING

The "First Step in Winter Comfort or Window Conditioning" is the title of a new brochure from the Libbey-Owens-Ford Glass Company. This brochure is well illustrated and has a descriptive text.

97. STAINLESS STEEL

A very handsome booklet has just come from the American Rolling Mill Company. It treats of their stainless steels and should prove to be quite worth while. The steels herein mentioned are the heat resisting grades.

98. PAINTS AND LACQUERS

From the National Lead Company, makers of the Dutch Boy line of paints, etc., comes a booklet illustrating the uses for these paints. It is called "Dutch Boy Painter." Send for your copy.

99. HOME LIGHTING

The Pacific Coast Electric Bureau has issued another of their splendid

little books, this one bearing the title "Light Condition Your Home." These books always are interesting.

100. REFRIGERATORS

The Westinghouse, borrowing from one of the current picture magazines, have brought out a booklet entitled "Look"—What can be done with a Westinghouse Refrigerator in Five Minutes". Send for your copy by clipping the coupon below.

101. FILING EQUIPMENT

An interesting booklet on metal filing equipment for all types of offices has been issued by the Art Metal Construction Company.

102-102A. PLYWOOD

Another broadside containing information and illustrations on plywood has been put out by the United States Plywood Corporation, whose booklets and pamphlets contain much instructive material. There are two in this series, one for residences and one of interest to the boat builder.

103. RADIATORS

To help in the sale of small homes the American Radiator Company has issued a booklet illustrating their heating units especially designed for modest cost homes. Send for a copy—the coupon will bring it at once.

104. OXY-ACETYLENE

The Linde Air Products Company's "Oxy-Acetylene Tips," an illustrated booklet, contains some facts worth knowing about this method of welding. The current number has quite a few new ideas which should be of value to the building profession.

105. AIR CONDITIONER

The Lincoln Electric Company has a new broadside just out on an industrial air conditioner. There are several illustrations and descriptive text.

106. DOOR TRIM

From the Kawneer Company, Niles, Michigan, comes a new booklet on doors and entrances in bronze or in aluminum. It is put out in a most interesting manner and contains photographs, text and plans. Send for your copy by using the coupon.

FREE FOR THE ASKING

Check items on coupon, paste on letter head or postal card, and mail to Architect and Engineer.

Architect and Engineer
68 Post Street
San Francisco, Calif.

Please send me literature on the following items as checked below. This request places me under no obligation.

94-94A	<input type="checkbox"/>	100	<input type="checkbox"/>
95	<input type="checkbox"/>	101	<input type="checkbox"/>
96	<input type="checkbox"/>	102-102A	<input type="checkbox"/>
97	<input type="checkbox"/>	103	<input type="checkbox"/>
98	<input type="checkbox"/>	104	<input type="checkbox"/>
99	<input type="checkbox"/>	105	<input type="checkbox"/>
		106	<input type="checkbox"/>

My Name.....

Name of Company.....

Street.....

City..... State.....

JOHNSON

Since 1904, the name of Johnson on an oil burner has been accepted as the seal of fine engineering, skilled craftsmanship and dependability. Johnson Burners on an architect's specifications insures satisfaction and comfort for the home owner. Johnson builds oil burners for every need of industry, commerce and home. Data sheets on each type of Johnson Improved Burners give complete information and specifications. Johnson engineers will be glad to assist in preparation of layouts & estimates.



THERE'S A JOHNSON OIL BURNER FOR EVERY PURPOSE

AIR-CONDITIONING? See the Johnson SELECTAIR, a compact, efficient unit which offers every desired feature for economical heating, air-conditioning and ventilating the home. With year-round domestic hot water. Oil-fired by the Johnson Pressure-type "Bankheat" Burner.

BOILER-BURNER UNIT? Test the "LADDI DU-ALL", a compact and completely automatic unit furnishing heat and hot water for small and medium-sized homes and apartments at low initial cost. ... *Descriptive bulletins on request.*

S. T. JOHNSON CO.

940 ARLINGTON, OAKLAND, CALIFORNIA
401 N. BROAD STREET, PHILADELPHIA, PA.

"I DIDN'T HAVE AN ARCHITECT!"

YES, but you should see his house! He's got dark halls, insufficient closet space, poor lighting, faulty room arrangement—we could go on ad infinitum—but "he wouldn't know." * He paid for a DAY and NIGHT Water Heater—he'll probably pay for the equivalent of two DAY and NIGHTS over a period of years—but he didn't get one. He just bought a water heater. * How should he know about the patented HEAT TRAP—HEAT WAVE FLUE and other exclusive DAY and NIGHT features that would save him many dollars every year of DAY and NIGHTS long life? * But the point is, his architect would have known, and instead of a makeshift water heater, he could have had a DAY and NIGHT, America's finest, at the same price. * An architect's reputation is his "capital." When he specifies DAY and NIGHT, he does so secure in the knowledge that there is no finer water heater made. That's one important reason why DAY and NIGHT enjoys "First Place" in the esteem of architects and the public.



DAY and NIGHT WATER HEATER COMPANY
MONROVIA, CALIFORNIA

SIZES AND THICKNESSES OF DOUGLAS FIR PLYWOOD

Douglas fir plywood comes in stock panels up to four feet in width and eight feet in length, but larger panels may be obtained upon special order.

In thickness, fir plywood is manufactured from 3/16" (which may be sanded to 1/8") up to 1-3/16" in increments of 1/16". Greater thicknesses as required may be obtained for gusset plates and other special uses.

There is a suitable grade and an economical thickness of Douglas fir plywood for almost any use.

By gluing together the veneer so that alternate sheets have their grain running at right angles, the manufacturer of Douglas fir plywood capitalizes on the strength of wood along the grain.

Along the grain, wood has a tensile strength and stiffness many times greater than it has across the grain. Furthermore, wood has practically no expansion or contraction along the grain.

Consequently, through alternating the grain direction of the veneer sheets, fir plywood acquires longitudinal grain both lengthwise and crosswise and with it great strength and stiffness in all directions. At the same time, the stability of each sheet along the grain, plus the assured glue bond, prevents the adjacent sheets from shrinking or expanding when subjected to heat or dampness, resulting in plywood panels being practically immune against expansion or shrinkage.

All stock panels of Douglas fir plywood are manufactured with water-resistant glue.

Concrete form panels are made with special water-resistant glues to assure numerous reuses under severe moisture conditions.

Supplementing such plywood products is the strictly waterproof Douglas fir plywood manufactured with synthetic resin glues and hot pressed.

TABLE OF SIZES AND THICKNESSES OF STOCK PANELS

ITEM	WIDTHS	LENGTHS	THICKNESSES
Standard Panels	From 12", increasing by 2-inch units to 30"; also 36", 42" & 48"	48", 60", 72" 84" & 96"	3/16" (3-ply sanded 2 sides) increasing by 1/16" thicknesses to 1-3/16" (7-ply).
Wallboard	48"	60", 72", 84" & 96"	1/4", 3/8" (3-ply sanded 2 sides) and 1/2" (5-ply sanded 2 sides)
Sheathing (PLYSCORD)	32" and 48"	96"	5/16" and 3/8" (3-ply unsanded) and 5/8" (3-ply or 5-ply unsanded).
Concrete Form Panels	From 12", increasing by 2-inch units to 30"; also 36", 42" & 48"	48", 60", 72" 84" & 96"	1/4" (3-ply form liners), 1/2" (3-ply or 5-ply), 3/16", 5/8", 11/16" or 3/4" (5-ply).

(Larger or odd sized panels may be secured on special order.)

COMMISSIONED TO PREPARE PLANS

Clarence A. Tantau, Shreve Building, San Francisco, has been appointed by the City and County of San Francisco to prepare plans and specifications and to supervise the construction, decorations and furnishings of the interior of the San Francisco exhibit at the Golden Gate International Exposition, Yerba Buena Island Shoals.

PLYWOOD FORMS FOR BRIDGE ROADWAYS

THE San Francisco-Oakland Bay Bridge roadways on both upper and lower levels were laid with the use of $\frac{3}{4}$ " 5-ply "Locktite" Douglas fir plywood concrete form panels, the total job requiring approximately 400,000 square feet.

The outstanding performance of these panels is the fact that in this particular type of roadway construction involving the use of a concrete agitator, they were subjected to the most severe punishment possible while the number of uses that were obtained through careful handling amounted to approximately 12-15 in some cases.



Fig. 1

Figure 1 shows the manner of placement of these panels before pouring the concrete which forms the surface of the roadway. An interesting detail is the manner in which these panels had to be placed on a temporary supporting structure to permit removal after the completion of the roadway. In other words, all of the panels and structural work shown in this picture, with the exception of the steel girders, were removed from the bottom of the roadway upon completion of the cement work.

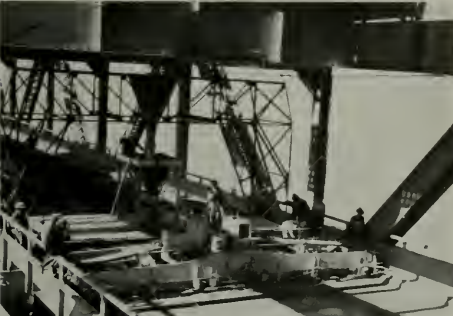

Fig. 2

Figure 2 shows operation of the agitator across the complete width of the roadway which process subjected these panels to such severe service. This picture shows the mixer placing the wet aggregates in front of the

agitator as it moves along performing its work of surface distribution. A completed part of the roadway after the agitator has done its work as well as an in-completed section towards which the agitator is moving, are clearly shown in the photograph.

Progressive builders use Locktite plywood forms because they save up to 50% of labor; eliminate costly rubbing, and speed up stripping and resetting. Engineers specify Locktite brand for more re-uses and smoother concrete finish.

ENDING EFFLORESCENCE

(Concluded from Page 12)

There is really only one way to kill efflorescence and its results surely . . . that is, by **stopping the water at its source**. This is frequently impossible.

Temporary results may be gained by washing the walls down with a solution of zinc sulphate, which takes the deposits off the surface and neutralizes the alkali. Muriatic acid is used sometimes, which removes the deposits or turns them transparent. Also, certain stearates have been used with varying results but they ruin the surface for painting.

But these efforts at best have all been in the way of **correctives after** the trouble has occurred . . . and must soon (six months or less) be repeated. What was obviously needed was a **preventative** . . . something that could arrest the capillary action that brought the destructive salts to the wall surface. It was after the definition of this basic problem that chemists brought out Laux Stopit . . . to be used with Rezicote, the synthetic resin bound paint for stucco, brick, masonry, and concrete exteriors.

Laux Stopit is an acid mixture, non-saponifiable, which, when mixed with kerosene and applied to the wall, prevents efflorescence by arresting the capillary action beneath the surface.

It is **not** a sealer and is only to be used under Rezicote, Laux synthetic resin paint. The two together have a double, complementary action which effectually stops efflorescence.

CEMENT INDUSTRY ON THE AIR

Portland Cement Association goes on the air September 25 over KSFO, in that station's weekly series "A Salute to Industry." The program features Walter Guild in an interview with J. E. Jellick, district manager of the Association. California State Chamber of Commerce co-operates in the series.

Mr. Jellick has been on the engineering staff of the Los Angeles County Road Department, the Wyoming State Highway Department, the Southern California Edison Company, and Washington Water Power Company of Spokane.

The new broadcasts will emphasize that California is fourth in per capita cement use in the United States and second in cement output with 37 states producing the product.

PLEASING HOME WITH HARBORSIDE EXTERIOR



HOUSE OF A. P. TANSCHER, PORTLAND, OREGON
DESIGNED BY J. WAYLAND OWEN
Exterior covering is Harborside

THIS interesting home is in Benz Park, Portland, Oregon. Designed by J. Wayland Owen, the entire exterior covering is composed of Harborside, a recent development of the Harbor Plywood Corporation of Hoquiam, Washington.

Harborside is made of Super-Harbord—the original outdoor plywood—which has been the acclaim of marine architects, watersports equipment builders, industrial engineers and others who have found in it the answer to their demands for a permanently waterproof plywood. It is hot-pressed with a cresol-formaldehyde synthetic resin binder, insoluble in water, fusing the plies together as solidly as a single board, and guaranteed against ply separation. This binder is toxic to termites, insects and rodents. It is impervious to the destructive effects of moisture and weathering, and yet, it has all the workability of wood plus the size and convenience of large panel units. It is free from perceptible change of size due to humidity change, and, consequently, is demanded for swell-proof, shrink-proof construction.

Harborside is manufactured with a shiplap edge rabbeting and may be laid up with the edges lapped, with edge joints flush (for restication moulds) or edges eased and laid up flush so as to form a slight "V" joint restication line.

Harborside is available in fir or redwood face. There is only one grade and it contains no face defects to require special painting or shellacking. It may be used on either new or old construction. It is delivered to the job clean and dry—ready to apply.

MODEL HOMES FOR EXPOSITION TOUR

Visitors to the \$50,000,000 Golden Gate International Exposition on San Francisco Bay next year will be able to visit a series of model homes embracing authentic architectural designs from countries all over the world.

In the Exposition Model Homes Tour a necklace of beautifully designed homes about San Francisco will include representative architecture of foreign nationality. These various locations will be carefully selected so that the landscaping and topography may be in complete harmony with the design. Some of California's leading architects are at work on the plans. Drawings of unusual merit and beauty, which have already been submitted, indicate that this tour will be the outstanding architectural event of 1939.

Stated President Edwyn A. Hunt of the Exposition Model Homes Tour, "It is our plan to have each tour model home builder adopt a theme that will be carried out not only in the architecture but furnishings, decoration and landscaping as well.

"For example, in Marin County two theme homes are being considered for locations already entered in Exposition Model Homes Tour. One of these may take the form of modern architectural adaptation of a picturesque Irish cottage, to be set in the green wooded hills of Sleepy Hollow, to be built by the Lang Realty Corporation. On Belvedere Island, the Belvedere Land Company is considering the adaptation of a Mediterranean Villa for a \$25,000 tour home, with hanging gardens running down to the water's edge.

"In Berkeley, the Mason-McDuffie Company is planning a true New England colonial home, reproduced in all the simple beauty of this country's oldest New England coast homes. Down the peninsula, near Redwood City, plans are being discussed for reproduction of one of California's oldest Spanish haciendas, bringing to life again the gay atmosphere of the days of the Dons, according to Ludwig Werder, president of the Redwood City District Real Estate Board. In back of Piedmont, Emge & Stockman are talking of a true reproduction of the early California farm house type of home, adapted to the hill area of Montclair highlands."

DOUGLAS FIR PLYWOOD LITERATURE

Request to the Douglas Fir Plywood Association, Tacoma, Washington, will bring copies of any of the following.

Douglas Fir plywood, how and where to use it.

Specifications and suggestions for interior paint decoration on Douglas Fir plywood.

Deflection charts for Douglas Fir plywood.

Grade use guide.

Sheathing and subflooring of Douglas Fir plywood.

Tests at U. S. Forest Products Laboratory (Strength and Rigidity of Frame Walls).

Handbook of Douglas Fir plywood.

Sure—Anyone can nail plycord.

American Douglas Fir plywood and its uses (Dept. of Commerce publication).

Concrete forms of Douglas Fir plywood.

How to finish Douglas Fir plywood.

Construction Bulletin No. 1—Money-Making Plans for Builders.

Industrial Bulletin No. 1—Check these advantages of this engineered lumber against your production problems.

Construction Bulletin No. 7—How to build a "Fun Room" for the whole family.

Trench sheathing with Douglas Fir plywood.

Build rumpus-proof rumpus rooms with Douglas Fir plywood.

Hanging wallpaper over Douglas Fir plywood.

Job-fabricated and shop-fabricated systems in residential construction with Douglas Fir plywood.

Plycord sheathing for walls, roofs and subfloors.

Interesting and informative literature on the products of producers of Douglas Fir plywood may also be obtained by addressing the individual mills advertising in this issue.

STREAMLINER DOORS

(Concluded from Page 8)

new "Streamliner Door" manufactured by the Wheeler Osgood Sales Corporation in Tacoma, Washington, is made with plain panel surfaces of three-ply Douglas fir or Philippine mahogany. A rigidly braced, hollow core provides ample strength and yet is

light in weight. It has a series of channels, screened at interior openings which allow thorough circulation of air for resistance to the warping effects of moisture and temperature changes.

The plain panel, of Laminex construction, has been soundly engineered and built to balance the stresses caused by the natural shrinkage of wood. Crossing the grain of each successive ply neutralizes the effect of expansion and contraction. The Laminex cement in holding the individual panels together provides a permanent, moistureproof bond.

The plain paneled surface of the "Streamliner Door" offers wide possibilities in decorative effects. It can be painted or stained to fit in perfectly with any decorative effect desired. Virtually any arrangement of panel effects can be obtained and, in addition, striking inlaid and routed designs are easily provided.

SPECIFY

RESNPREST

(PHENOL FORMALDEHYDE RESIN BONDED)
ALL PURPOSE ALL WEATHER LAMINATED WOOD

For All Modern Streamlined Exterior Construction

Most efficient, most economical building material on the market today. The only Douglas fir plywood bonded with genuine, pure phenol formaldehyde resin—a bond water can not penetrate; heat, cold, time, tide can not affect; resistant to fungi, mold, fire. Available in large economical panels stronger than steel by weight, split proof, crack-proof, time and labor saving. Perfected by M and M Woodworking Co., largest plywood manufacturers in United States. At leading dealers and jobbers.

Ideal for

BOATS - SIGNS - HOME EXTERIORS - SERVICE STATIONS
AIRPLANE HANGARS - INDUSTRIAL PLANTS - FARM BUILDINGS
STORE FRONTS - MARQUEES - GARAGES

TEST IT

WRITE FOR

FREE SAMPLE RESNPREST



M and M

WOODWORKING CO.

PORTLAND, OREGON

Specify

CONDITIONED AIR HEAT with the DELCO CONDITIONAIR

Product of General Motors

● The Delco Conditionair automatically heats, humidifies, filters, circulates healthful air throughout the home. Many exclusive features that contribute to greater economy and durability. Models for oil or gas. Get all the facts.

ALADDIN HEATING CORPORATION

Delco-Frigidaire Dealer

2222 SAN PABLO AVENUE • OAKLAND



FOUNDATIONS AREN'T ALL UNDER THE HOUSE

There is, for instance, the foundation for electrical service that is hidden in the walls — the wiring system.

Upon it rests the weight of the scores of demands that will be made for electrical service every day the building is occupied.

That foundation must provide not only for present demands, but for increasingly heavy loads in the years immediately ahead.

Failure of this basic system means either years of makeshift and inconvenience, an expensive new foundation system, or additions to the inadequate one. In any case the architect comes under severe criticism unless he has included in his original plans provision for proper wiring.

Our free Red Seal plan gives a minimum standard as a basis from which to work. Free consultation service on wiring problems, too, if you wish.

PACIFIC COAST ELECTRICAL BUREAU

447 Sutter Street
SAN FRANCISCO • CALIFORNIA

601 W. 5th Street
LOS ANGELES

CIVIL ENGINEERS MEET

The American Society of Civil Engineers, San Francisco Section, held its regular bi-monthly meeting August 16 at the Engineers Club, San Francisco, with President Ralph W. Wadsworth presiding.

The principal speaker was Dr. Karl F. Meyer, director of the Hooper Foundation for Medical Research, University of California. His subject was "Animal Diseases Transmissible to Man, Especially in Relation to Engineering and Construction Work in Rural and Mountainous Regions." Dr. Meyer said "We all recognize the interest in the Public Health Engineer whose skill provides and maintains the safeguards of sanitation and a pure water supply, which are the foundations of existence of our modern sanitation and industrialization."

Gerald E. Arnold, Chief Water Purification Engineer of the San Francisco Water Department, spoke on "Recent Developments in Water Treatment." He was well qualified to discuss this subject because of his connection with the City of San Francisco.

C. C. Kennedy, consulting engineer, San Francisco, discussed "Recent Developments in Sewage Treatment." Mr. Kennedy has been retained on several sewage disposal plants in the cities of the Bay Area.

Dr. John P. Russell, chief of the Industrial Hygiene Service, California State Department of Public Health, was called on to lead the discussion on "The Industrial Hygiene Service of the California State Department of Public Health." He brought out the point that the engineers' contribution to the art should not be the only one emphasized, but that the inter-dependence and correlation of physicians and engineers should be considered.

Fred Ingram, engineer of the Industrial Hygiene Service, California State Department of Public Health, reviewed the works of the new State Bureau and the opportunity for engineers and physicians to collaborate in this field of activity, that of industrial hygiene.

FRANCIS J. PLYM HONORED

During the recent Swedish Tercentenary celebration, dedicated to the landing of the first Swedish party in America, Francis J. Plym, president of the Kawneer Company, was highly honored by the King of Sweden. The decoration was the Commander of Vasa, which is awarded rarely, and carries with it a very high distinction.

Prince Bertil pointed out that the honor was paid Mr. Plym for the splendid work he had done in connection with the Tercentenary, for his contributions to educational and other institutions in this country and in Sweden, and for his general achievements as an inventor and manufacturer.

Mr. Plym, formerly a practicing architect, is the originator of resilient rustless metal store front construction in 1905, and of the first light aluminum or bronze type of residential window in 1933. He is highly regarded as president of the Kawneer Company and also as donor of the Plym Architectural Scholarship, University of Illinois.

ARCHITECTS AND FEDERAL HOUSING PROJECTS

Contract provisions accepted as standard by the American Institute of Architects are embodied in the agreement for architectural services on housing projects prepared by the United States Housing Authority, it is pointed out by William Stanley Parker, vice-chairman of the Institute's Committee on Housing. The customary phraseology is extended and adapted to meet the special requirements of housing projects which come under the United States Housing Act of 1937.

"The architectural profession is greatly indebted to Housing Administrator Nathan Straus for his recognition of the fact that these housing projects are not Federal projects but local ones which should be carried out as far as possible in accord with sound procedures developed as a result of long years of experience in private architectural practice," Mr. Parker declares.

"The provisions make quite clear that the architect is to render customary full professional services. With this full responsibility goes the responsibility to design the project so that it can be constructed within the amount of money available. If no bids are received that will permit this, the architect may be required at his expense to make such revisions in the plans and specifications as may be necessary to insure the proper construction and completion of the improvement within the estimated improvement cost.

"The architect is protected by the inclusion of a provision that he shall be equitably paid for any extra expense and service involved due to the delinquency or insolvency of the local Authority or contractor, or as a result of damage to the improvement by fire, earthquake, flood, or other natural calamities."

The architect is required to submit preliminary drawings to the various local, state, or Federal agencies having jurisdiction over the project and to obtain their approval. He prepares the form of proposal, assists in the advertising for proposals, secures bids, and awards contracts. The form states that he is to be present at the public opening of bids to review and tabulate the contractors' proposals and to make recommendation to the local Authority for the award of the contract.

The construction of the improvement is to be supervised by the architect, who guards the local Authority against defects and deficiencies in the work of the contractors, but does not guarantee the performance of the work by them.

"The contract also makes clear the usual distinction that the supervision of the construction by the architect is to be distinguished from the continuous personal superintendence which may be obtained by the employment of a clerk-of-the-works," Mr. Parker explains. "It follows regular private practice in providing that, when authorized by the local Authority, the clerk-of-the-works and other inspectors acceptable to both the local Authority and the architect shall be engaged

ENGINEERED HARDWARE

FOR NEW SCHOOL CONSTRUCTION

DALMO SIMPLEX WINDOW FIXTURES

"THE NATION'S SCHOOLHOUSE WINDOW"

HAVE BEEN USED IN OVER 200 SCHOOLS IN CALIFORNIA IN THE PAST TWO YEARS

KRAMER FLUSH VALVES

SHEER SIMPLICITY OF CONSTRUCTION MAKES FOR POSITIVE PERFORMANCE AND LOW MAINTENANCE



YUkon 0123

963 Harrison St.

San Francisco

"Goods of the Woods"

Dependable Building Materials

Lumber and Millwork

for

All Types of Construction

★

Wolmanized or Creosoted
Lumber and Timbers
is your protection against
Termites and Decay

★

E. K. WOOD LUMBER CO.

San Francisco

Los Angeles

Oakland



IT'S NOT A HOME

(Commercial or Private)

WITHOUT

Beautiful Trees and Shrubs

MAKE THE

FACTORIES

WHOLESALE HOUSES

PRIVATE HOMES

Really look like

California

Largest selection of specimen plants in California — from which to plan your proper and liberal planting.

Roy F. Wilcox & Co.

WHOLESALE GROWERS

MONTEBELLO (Los Angeles County) CALIFORNIA



MISSION INN

One of Monterey's oldest historic buildings, yet offering the most modern convenience and comfort to travelers.

Plan to visit Monterey, Carmel and Pebble Beach . . . and plan to stop at this unusual Inn of early California charm.

Private parking.

IN HISTORIC

MONTEREY

**Pressure
Treated Lumber?**

Specify

BAXCO CZC

**"Chromated Zinc
Chloride"**

**Protects against decay
and termite attack**



*Available for prompt shipment
throughout California*



J. H. BAXTER & CO.

601 W. 5th Street
LOS ANGELES
Phone Michigan 6294

333 Montgomery Street
SAN FRANCISCO
Phone DOuglas 3883

by the architect at salaries satisfactory to the local Authority and paid by the Authority upon presentation of the architect's monthly statements.

"The detailed itemization of the various elements of the architect's work during the construction period includes the provision that he shall check and report on contractors' proposals in connection with changes in the contract, whether or not involving change in the contract price, and requires also the approval of certificates for payment."

The designation "architect" embraces the professional group responsible for the entire operation, including architectural, site planning, engineering, and landscaping services. This group is protected in the contract against price changes beyond its control.

Payments to the architect are in general accord with common practice but devised to conform specifically to the required stages of submission of drawings for approval. They are to be made as follows:

A first installment of 15 per cent upon approval of preliminary drawings; a second installment of 20 per cent upon approval of the pencil working drawings; a third installment of 15 per cent upon approval of complete working drawings and specifications; a fourth installment of 10 per cent upon execution of the construction contract; progress payments during construction aggregating 35 per cent; final payment of 5 per cent upon acceptance of the improvement.

Arbitration of all questions in dispute under the agreement is provided for, in accordance with the rules and under the administration of the American Arbitration Association.

SOUTHERN CALIFORNIA CHAPTER

At the August 9th meeting of Southern California Chapter, A.I.A., fees charged for residential work and practices employed in handling residence commissions were discussed in open forum. A number of the architects related methods they use in establishing fees, while a few offered solutions of arriving at an equitable means of charges for services on residence work.

Sumner Spaulding, chairman of the Chapter's Civic Center committee, reported on the activities of the citizens' committee for the Los Angeles county building program and stated that John C. Austin, a member of the committee, had done a creditable job in preparing a diagrammatic plan for the improvements.

Carleton M. Winslow said the plan was the most practical one that had been advanced so far.

A report on legislative matters was made by Earl T. Heitschmidt, chairman of that committee.

Eugene Weston, presiding, stated that the Chapter had sent a letter to the Board of Supervisors suggesting the competition method in selecting architects for the new county courthouse. He said that a letter had also been sent to the Board of Public Works suggesting the same method of selecting architects for at least one of the three proposed new city buildings.

No Worry for the Architect

"—All acid proof drain pipe and fittings shall be Ferro-silicon—CORROSIRON—"

[Write for this specification]



FEDERAL BUILDING • CIVIC CENTER • SAN FRANCISCO

Arthur Brown, Jr., Architect

CORROSIRON DRAIN LINES and FITTINGS and LABORATORY EQUIPMENT was specified because of its superior resistance to corrosion and wear.

Pacific Foundry Company, Ltd.

NEW YORK • 3100 NINETEENTH ST., SAN FRANCISCO • LOS ANGELES

BUILD WELL~

A PROPERLY designed and well constructed building is a credit to any city and a profitable investment for its owner.

Such structures are the STAND-ARD OIL BUILDING, MATSON BUILDING, FOUR-FIFTY SUT-TER STREET, STOCK EXCHANGE, S. F. BASE BALL PARK, MILLS TOWER, OPERA HOUSE and VETERANS' MEMORIAL, San Francisco, OLYMPIC CLUB AL-TERATIONS, SANTA ANITA RAC-ING PLANT and other notable structures — all built or super-vised by —

Lindgren & Swinerton, Inc.

Standard Oil Building
San Francisco

605 W. Tenth Street
Los Angeles

We Maintain a Termite Control Department

POMONA TILES

FOR
Bathrooms and Kitchens
in over 60 colors

Warehouses and Display Rooms

135 Tenth St. . . . San Francisco
629-33 North La Brea Ave. Los Angeles
6106 Roosevelt Way Seattle

POMONA TILE MFG. CO.
PLANT — POMONA, CALIF.



Write for "The Charm of a Well Lighted Home"—to help you plan attractive healthful lighting.

Traditional and contemporary designs of Lightoller fixtures are on display in our showrooms. Whether you are working on a new or modernized home you'll find the very designs you want at Incandescent.

INCANDESCENT SUPPLY CO.
SAN FRANCISCO : OAKLAND : FRESNO : LOS ANGELES

HARER GAS FURNACES HEAT

Consult us for the answer to your problems

HARER-PERRY COMPANY

5662 Keith Ave., Oakland, California

Phone HUmboldt 7928

A Permanent Exposition
of the newest ideas
in home planning
and equipment.



THE BUILDING MATERIAL EXHIBIT

Architects Bldg. • Fifth & Figueroa • Los Angeles • MU-6306

Considerable time was devoted to a discussion of the merits of the public building programs in Los Angeles, as now proposed, the majority of the members apparently agreeing on the suitability of the existing buildings in their present locations as a nucleus for the Civic Center.

The activity of the local art groups in procuring an art center building for Los Angeles was related by Paul Robinson Hunter. A grant to help finance such a structure will be requested of the Public Works Administration.

BOOK REVIEWS

THE BIG FOUR: By Oscar Lewis; Alfred A. Knopf, New York; Price: \$4.50.

It is not often that a nation-wide best seller comes to the book review desk of a technical publication. There are exceptions to the rule, however, and this is one of them.

The engineering features and the stupendous problems that faced the builders of the trans-continental railroad give "The Big Four" a definite place on the review pages of every publication, especially if published in California, because the history of the railroad and its builders is the history of California.

Written clearly, concisely and with great frankness, showing the results of intense research, this book is liberally illustrated.

The author of "The Big Four" is a native Californian, a man to whom should go every credit for giving us one of the very worthwhile books of the year. The first and oldest architectural publication of the West is delighted to include this word of praise of Oscar Lewis in its review pages.

AIR CONDITIONING: By Charles A. Fuller; The Norman W. Henley Co., 2 West 45th Street, New York City, N. Y.; Price: \$4.00.

A brand new book on one of the most important subjects in the building industry of America today. Written by a foremost authority, an engineer who has devoted his professional life to his subject, the book contains much that the professional man will find worth while, particularly with reference to air conditioning problems.

NINE CHAINS TO THE MOON: By R. Buckminster Fuller; J. B. Lippincott Co., Philadelphia, Pa.; Price: \$4.00.

This book has much in it of interest to the professional man and is calculated to arouse some curiosity and, no doubt, provoke not a little controversy. The architect will find something here that will probably cause him to wonder, but the answers are there if he will accept them.

"Nine Chains to the Moon" might well be termed a "streamlined" philosophy of modern thought with building playing a considerable part of this thought.

NEW PLYWOOD FINISHES

Two new products that extend the usefulness of plywood as a building material, have just lately been introduced by I. F. Laucks, Inc., glue and paint manufacturers, Portland Oregon, and whose long and intimate association with the plywood industry has placed them in a most advantageous position for the development of such products.

These two products are known to the trade as Rezitex (for exteriors) and Plasterez (for interiors).

Both are synthetic resin bound paste paints, thinned with mineral spirits and both offer the unique advantage to plywood construction of being fire-resistant. Certified tests with both Rezitex and Plasterez prove these new paints withstand a 1 1/2 hour fire . . . also standard laboratory tests of 180 degrees F. over open Bunsen burner flame for five minutes.

Rezitex may be applied on exterior plywood that is certified by the manufacturer for outside use. It does not impart waterproofing of waterproofing qualities to ordinary plywood, although it does give a heavy, durable, protective coating to the plywood surface.

Both paints are heavy bodied wall coatings which cover minor imperfections, joints, etc. in the plywood surface, and which provide a surface which may, if desired, be stippled or textured to simulate conventional plaster, stucco, or concrete walls. The plywood for either interior or exterior applications must first be sealed, at the mill (Rezitized-at-mill) or on the job with clear synthetic resin sealer.

The materials cover from 150 to 300 square feet, depending upon the surface and the depth of the texture desired, if any. Both paints are supplied in white only, but may be tinted with colors in oil or the surface decorated with synthetic resin bound paints or standard finishing materials.

For the new dry-built type houses where plywood is considered the best of all materials, these new products with their beauty, durability and fire-resistance are considered ideal.

While originally developed for application to fir plywood, it has been proven that these paints are suited to application on interior or exterior stuccos, plaster, plasterboards, cement, brick, etc., especially where re-surfacing seems to be needed.

CHESTER COLE, ARCHITECT

Chester E. Cole, 55, architect of Chico, California, died suddenly at his ranch in Butte County, August 10.

Mr. Cole spent thirty-two years in Chico and was a member of the architectural firm of Cole & Brouchoud. Many of the more prominent buildings in Chico, including the State College, were designed by Mr. Cole and associate.

Mr. Cole leaves a widow and three sons, Phillip, John and James Cole, all of Chico; a brother, Ernest Cole of Culver City, and a sister, Mrs. Oscar Blake of Santa Ana.

INCLUDE TREES IN YOUR PLANS

DAVEY, ORIGINATOR OF TREE SURGERY, OFFERS FREE INSPECTION AND ESTIMATE.



SAN FRANCISCO Russ Bldg. SUHter 3377
 Fresno Mattei Bldg.
 LOS ANGELES Story Bldg. TUCKer 1929
 Local phones in: Pasadena, Palo Alto, Oakland, San Rafael, San Mateo

SKILL - KNOWLEDGE - RESPONSIBILITY

STRUCTURAL STEEL

For Class A Buildings,
 Bridges, etc.

JUDSON PACIFIC CO.

609 MISSION STREET
 SAN FRANCISCO

Plants: San Francisco - Oakland

USE BASALITE

Light-weight, pre-fabricated Concrete building products for floors, walls, and roofs in your next building.

BASALT ROCK COMPANY, INC.

Napa, California

NOISE Control

Office Quietng
 Sound-proof Partitions
 Acoustical Correcction

WESTERN ASBESTOS CO.

Building Materials Mechanical Specialties
 SACRAMENTO OAKLAND
 SAN FRANCISCO



No longer a problem
for the Architect

TRANSIT MIX CONCRETE AND MORTAR

makes delivery of material to the job swift and inexpensive . . . minimizing the architect's supervision costs and assuring his client a dependable mix.

Speed . . . Reliability . . . Economy
Let us co-operate with you

Golden Gate-Atlas Materials Co.

16th and Harrison Streets
San Francisco
UNderhill 3650

Modern Design Dignified and Good Looking



Model No. 75

This new semi-recessed HAWS DRINKING FOUNTAIN is made of Vitreous China and answers a demand for an attractive, well built fixture for public and semi-public buildings.

HAWS DRINKING FAUCET CO.
1808 Harmon Street Berkeley, Calif.

"SAN FRANCISCO OF 1999"

San Francisco as it may appear at the close of the present century, will be visioned by millions of visitors to the 1939 Golden Gate International Exposition on Treasure Island.

In the huge Hall of Mines, Metals and Machinery, the city of San Francisco in the year 1999 will be portrayed according to a definite architectural and engineering plan. The exhibit, which will form part of the United States Steel Corporation's \$250,000 display, will be in the form of a large diorama 35 feet long and 8½ feet deep.

This vision of the bay city sixty years hence is no wild imaginative dream, but an actual plan for rebuilding the city, showing what modern architects and engineers working in steel could accomplish. Not only is the scheme capable of actual fulfillment but feasible. It could be carried out without razing the existing structures before their normal obsolescence and without interruption of the city's normal functions.

Fulllest advantage has been taken of the city's natural features. Streets and avenues on flat or comparatively flat terrain remain unchanged except that alternate streets have been removed to create "super-blocks". Streets and avenues on the slopes have been redesigned to follow the natural contours. This arrangement eliminates steep inclines completely and creates instead an effect of terraced drives. These curving streets occur in residential areas only.

San Francisco's present acute traffic problem, due largely to the scattered and disorganized terminal facilities, is corrected in the new plan, by a huge terminal and pier at the foot of Sixteenth Street, serving all the transport lines, both passenger and freight. Both Sixteenth Street and the terminal are built in several levels to accommodate with maximum efficiency the several kinds of traffic concentrated there.

At the lowest level (the second underground) is the subway, the next two levels for trucks, the one below ground for westbound vehicles from the pier, and the one at ground level for east-bound. All the city's warehouses are

Donovan Automatic Awning Type Windows

Give 100% natural ventilation
and day-lighting control

UNIVERSAL WINDOW
COMPANY
Berkeley, California

"AMERICAN MARSH" Redi-Vac Vacuum Heating Pump

Send for
Bulletin 441

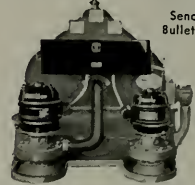

SIMONDS MACHINERY CO.
San Francisco Los Angeles
816 FOLSOM ST. 522 EAST 4TH ST.

SISALKRAFT

REG. U. S. PAT. OFF.

"More than a
building paper"

THE SISALKRAFT CO.

205 West Wacker Drive
(Canal Station) Chicago, Ill.
55 New Montgomery Street
San Francisco, Calif.

Pacific Manufacturing Company

High Class Interior Finish
Quality Millwork

142 Sansome St. 6820 McKinley Ave.
San Francisco Los Angeles
GARfield 7755 THORnwall 4196

1315 Seventh Street, Oakland
GLEncourt 7850



CLIENTS will bless you for installing the Wesix "49'er" ELECTRIC BATHROOM HEATER. But try it first in your own home. Certain that you will like its forty-nine inches of INSTANT RADIANT HEAT and QUICK CIRCULATING HEAT, we are offering this smart new heater at factory cost to architects, for personal use! Limit one heater per architect. List price \$21.50. Please write on your regular letterhead, to: 1018 WESIX BLDG., SAN FRANCISCO

WESIX
WESIX ELECTRIC HEATER CO.



**HERRICK
IRON WORKS**

STRUCTURAL STEEL

16TH AND CAMPBELL STS.
OAKLAND, CALIF.
Phone G Lencourt 1767

**FORDERER
CORNICER WORKS**

Manufacturers of

Hollow Metal Products
Interior Metal Trim
Elevator Fronts and Cabs
Metal Plaster Accessories
Sanitary Metal Base
Metal Cabinets
Flat and Roll Metal Screens
Commercial Refrigerators

269 POTRERO AVE.
San Francisco, Calif.
HEmlock 4100

concentrated along the south side of Sixteenth Street, adjacent to the industrial area, with ramps connecting with the lower level of the street. The elevated level of Sixteenth Street is for automobile and bus traffic.

Trains from the south will follow the shore to the terminal, and those from the north and east will come over the Bay Bridge. For convenience in transferring cargo from train to ship, tracks extend out onto the pier at the end of which is a commercial airport with a catapult for take-offs.

This huge pier affords twelve miles of wharf space and four million square feet of storage space. Improved methods of loading make further dockage facilities unnecessary, so the existing waterfront is replaced with a beautiful landscaped shore drive connecting with the two bridges and the Coast drive.

Even today this concentration of terminal facilities would go far toward solving the traffic problem. Additional features of the plan include the widening of the remaining streets, the creation of cloverleaf intersections at points of heavy traffic convergence, the elevated highway which connects the hilltop communities and forms a by-pass around the business section, the shore drive connecting the bridges and encircling the city, the parking areas under the business buildings, and subway lines to replace surface cars.

In the commercial area the super-blocks are 550 by 800 feet. Each block has one skyscraper about thirty stories in height, but constructed so that the additional stories may be added for future expansion. The remaining area of the block is devoted to one-story shops and landscaping. Ramps give access to the basement parking areas.

Super blocks in the industrial section permit the planning of factories, warehouses, etc., in more open, airy and sunny surroundings. Factories in general are built around the perimeter of the blocks, with ample interior space for parking and gardens. None is higher than five stories. With smoke and soot completely eliminated by 1999, color and artistic design will be practical in industrial buildings.

*A few hours
a few dollars*
AND
Sealcon

WILL MAKE YOUR
BASEMENT



SEALCON forms a water-resisting seal for basement walls and floors, brick, stucco or any other masonry. Just paint it on, inside or outside, to any wet or dry surface. One coat gives lasting protection . . .

conquers
dampness
and seeping
water. A
perfect
base, or
mixture, for
oil paint.

EASIER
TO APPLY
THAN PAINT



ASK DEALER
LISTED
BELOW
ABOUT

Sealcon

GUNN, CARLE & CO.
Distributors
SAN FRANCISCO
20 Potrero Ave. Underhill 5482

HIGH FIRED

Kraftile

THE TERRA COTTA WITH THE 10 ADVANTAGES

Master Kraftile . . . Terra Cotta Wall Units . . . Ceramic Facings . . . Cutting Machines . . . Swimming Pool Ladder Steps . . . Swimming Pool Overflow Hand Rails . . . Bathroom Accessories . . . Enameled Brick . . . Special Shapes

See *Sweets Architectural Catalog*, No. 11-5,
Section 11, Fifth Catalog

KRAFTILE COMPANY
NILES - CALIFORNIA
(San Francisco Bay Area)

Pitcher

Improved
Disappearing Doors
Save 20% Space

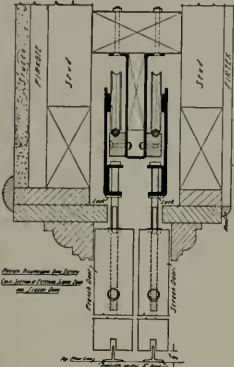

Joins with a 3/4" stud wall . . . steel studs
. . . adjustable steel and wood track.
Can be used for screen doors in connection
with French doors. Send for detail drawing.

E. C. Pitcher Co.

461 Market Street
San Francisco

Independent Iron Works

Structural Steel
Ornamental Iron
Steel Service Stations
Steel Tanks
Standard Steel Mill Buildings
Bridges

821 Pine Street

Oakland

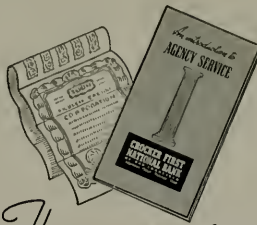

The practical way

TO HANDLE SECURITIES

With an Agency Account you retain complete authority over your holdings, but we relieve you of all time-consuming and irksome details. A simple letter of instructions is the only authorization needed to open an account. On request we shall be glad to send you our interesting booklet, *An Introduction to Agency Service*.

Ask for Booklet M-2

**CROCKER FIRST
NATIONAL BANK**
OF SAN FRANCISCO
California's Oldest National Bank

COMFORT

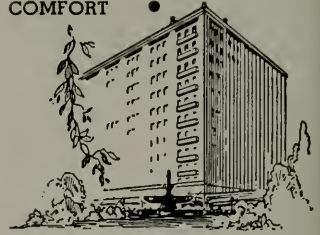

New **HOTEL
CLARK**
in Downtown
LOS ANGELES

Convenience is another offering of this hotel. Whether on business or pleasure bent, the Hotel Clark makes an ideal "base of operations," as well as a restful "billet," at the end of the day's "campaign." Good Food, naturally. And moderate charges, as well as for room accommodations, give final significance to assuring word — COMFORT

Single from \$2.50

Double from \$3.50

ROOMS
555
BATHS

Fifth and Hill

P. G. B. MORRIS, Manager

Louis C. Dunn, Inc.

GENERAL
CONTRACTORS

Monadnock Building
San Francisco

Phone: DOuglas 4632

ANDERSON & RINGROSE

General Contractors

320 Market Street, San Francisco

Phone GArdfield 2245

Clinton Construction Co. of California

General
Contractors

923 Folsom Street
San Francisco
SUtter 3440

Empire Construction Co., Ltd.

Builders

RUSS BUILDING
SAN FRANCISCO
SUtter 2989

HIGH GRADE MILLWORK
AND INTERIOR FINISH
SASH AND DOORS

LANNOM BROS. MFG. CO.

FIFTH AND MAGNOLIA STREETS
OAKLAND, CALIFORNIA
Telephone: TEMplebar 3663

MULLEN MFG. COMPANY

BANK, STORE AND OFFICE
FIXTURES—CABINET WORK
OF GUARANTEED QUALITY
CHURCH SEATING

Office and Factory:
60-60 RAUSCH ST., 8th, 7th and 8th Sts.
San Francisco
Telephone UNDERhill 5815

G. P. W. JENSEN & SON

Building Construction

320 Market Street, San Francisco
Phone: GARfield 2444

DINWIDDIE CONSTRUCTION COMPANY

BUILDERS

CROCKER BUILDING
SAN FRANCISCO

Carl T. Doell Co.

Plumbing
Heating

Plumbing Contractor
Veterans Memorial Building
Oakland

467 21ST STREET
OAKLAND

Telephone GLencourt 8246

Surrounding the Civic Center are universities, stadia, theaters, department stores, churches, clubs, hotels, etc. Seven hilltop communities form the outstanding feature of the residential section. Precipitous slopes have been cleared of existing structures and turned into protective green belts, while at the hill crests are 20, 30 and 40-story apartment houses, disposed to insure maximum light, air and view. Each hilltop community houses from 5,000 to 20,000 people, and each has its own community center, shops, schools, landing field and parking areas. A wide elevated highway connects the seven hilltops, with spiral ramps giving access to the lower levels of the city.

The super-blocks in the lower residential areas are approximately 500 feet square. Individual low-cost homes of steel and three-story apartments are both used. All are planned for maximum light, air and use.

THE CARPENTER'S LIMITATIONS

Dear Editor:

The providing of food and shelter are man's greatest activities. The man with his plow feeds the nation and the man with his blueprint shelters the nation.

Dictionaries define the word "Architect" as meaning a person skilled in the art of building.

Carpentry is the most technical of all the building crafts and as the master carpenter knows much about drafting, he often draws plans for valuable buildings.

This is an age of specialties, therefore the carpenter should limit his activities to those of the man with his square and let the man with his blueprint draw the plans.

A greater mutual interest and good will would exist between architect and builder if the latter would lay out work ONLY from architect's plans. He would also relieve himself of the trouble connected with the laying out of work from poor plans prepared by amateurs.

The architect creates the building on paper and then he makes it into material form. His willing assistants are the draftsmen and the craftsmen.

The association of architects affiliated with a society of draftsmen, should also be affiliated with a society of craftsmen.

An able carpenter-foreman, holding a master carpenter's certificate issued to him by the architects, would feel grateful to the profession to the extent that he will not draw plans nor will he work from plans drawn by amateurs.

LUVINE OLE BERG.

San Francisco, August 17, 1938.

BEAUTY CLEANLINESS DURABILITY

All three combined
in one material —

FERRO-PORCELAIN

Exteriors of buildings, interiors of rest rooms, kitchens and bathrooms are all logical places for this material.

Inquiries promptly answered

FERRO ENAMELING CO.

1100 - 57th Ave., Oakland, Calif.

Smith Lumber Company

WHOLESALE - JOBBING - RETAIL
FACTORY AND BUILDING LUMBER
PLYWOODS - ROOFING
DISTRIBUTING YARDS

San Francisco	Oakland
•	19th Ave. &
4th & Channel	Estuary
MARKet 0103	FRuitvale 3174

YOUR INQUIRIES SOLICITED

JOSEPH MUSTO SONS-KEENAN COMPANY

MARBLE
and
ONYX

535 NORTH POINT STREET
SAN FRANCISCO
1801 S. SOTO STREET
LOS ANGELES

ABBOT A. HANKS, INC.
Engineers & Chemists

INSPECTING — TESTING — CONSULTING
CONCRETE • STEEL • MATERIALS
CHEMICAL AND TESTING
LABORATORIES

- RESEARCH AND INVESTIGATION •
- TESTS OF STRUCTURAL MATERIALS
- DESIGN OF CONCRETE MIXES
- SHOP AND ERECTION INSPECTION OF
STRUCTURES AND EQUIPMENT
- INVESTIGATION OF STRUCTURES
AND MATERIALS
- TESTS AND INVESTIGATION OF
FOUNDATION SOILS
- FIRE RESISTANCE AND INSULATION
TESTS

624 Sacramento Street, San Francisco

Phone GARfield 1164

Hunter & Hudson
Consulting Engineers

DESIGNERS OF HEATING
AIR CONDITIONING
VENTILATING AND WIRING
SYSTEMS, MECHANICAL
AND ELECTRICAL EQUIP-
MENT OF BUILDINGS

41 SUTTER STREET
ROOM 710

San Francisco California

Proven Finishes

Dunne's Satin Wall
Dunamel
Dunne Non-fading Sash
Colors
Cementex

Satisfaction assured when these
products are specified

FRANK W. DUNNE CO.

41st and Linden Streets
Oakland

VAUGHN - G. E. WITT Co.

Manufacturers and Distributors

- | | |
|--------------------------------------|---------------------------------|
| Pump Governors | Oil Heaters |
| Safety Pump Governors | Relief Valves |
| Automatic Gas Regu-
lating Valves | Oil Burner Governors |
| Gas Burning
Equipment | Oil Burners |
| Vacuum Pump
Governors | Oil Pumping Sets |
| Vacuum Regulating
Valves | Oil Valves |
| Continuous Flow
Steam Traps | Oil and Steam
Strainers |
| Thermostats | Duplex Oil Pumps |
| Reducing Valves | Rotary Oil Pumps |
| | Boiler Feed Pumps |
| | Water Heaters |
| | Boiler Feed-Water
Regulators |

4224-28 Hollis St., Emeryville, Oakland

**THE
HERMANN SAFE CO.**

MANUFACTURERS AND DEALERS

OF
FIRE AND BURGLAR PROOF
SAFES AND VAULTS, SAFE-
DEPOSIT BOXES, ETC.

200 HOWARD STREET

SAN FRANCISCO

GAfield 3041 - 3042

**REPUBLIC STEEL
CORPORATION**



Manufacturers of

ENDURO Stainless Steel; TON-
CAN Copper Molybdenum Iron
Sheets and Pipe; and Steel Pipe,
Sheets and Reinforcing Bar for
every building purpose.

Write for information

Rialto Building, San Francisco, Calif.
Edison Building, Los Angeles, Calif.
White-Henry-Stuart Bldg., Seattle, Wash.



SANTA MARIA INN

Santa Maria, California

*On the Coast Highway
between*

Los Angeles and San Francisco

OVER NIGHT

OR

JUST A MEAL

FRANK J. MCCOY, *Owner*
Geo. A. Thompson, *Manager*

El Encanto Hotel

Santa Barbara

*On the Riviera, above the
Old Mission*

Frank J. McCoy, *Owner*
Fred F. Pimental, *Manager*

Robert W. Hunt Company
ENGINEERS

Inspection - Tests - Consultation
Schools and Other Structures
Are Built as Designed

*When Construction Materials are
Inspected at point of Manufacture
and during Erection by*

ROBERT W. HUNT COMPANY

*Cement, Concrete, Chemical, Metallurgical,
X-Ray and Physical Laboratories*

Chicago - New York - Pittsburgh
Los Angeles - All Large Cities
San Francisco, 251 Kearny Street

**JOHN
CASSARETTO**

—Since 1886—And Still Active—

Building Materials

READY MIX CONCRETE
ROCK - SAND - GRAVEL - LIME
CEMENT - PLASTER - MORTAR
METAL LATH - WOOD LATH
STUCCO - WIRE NETTING

Service Unexcelled

Bunkers
Sixth and Channel, San Francisco
Phones: GARfield 3176, GARfield 3177

**FINE WATER COLORS
AND PAPERS
FOR ARCHITECTURAL
RENDERINGS**

**H. S. CROCKER
COMPANY, Inc.**

720 MISSION STREET
MARKET STREET AT SECOND
SAN FRANCISCO

**THE TORMEY
COMPANY**

GENERAL PAINTERS
AND DECORATORS

Phone UNDERhill 1913

563 FULTON STREET
San Francisco

ARCHITECTS' AND ENGINEERS' SPECIFICATION INDEX

Classified Directory of Building Material Manufacturers, Dealers and Contractors

*Denotes subscribers of ARCHITECTS' REPORTS, sponsored and endorsed by State Association of California Architects, and published daily by THE ARCHITECT AND ENGINEER. Other firms listed are regular advertisers, in addition to Reports.

ACOUSTICAL AND SOUND CONTROL
ARMSTRONG CORK PRODUCTS Co., 1355 Market Street, San Francisco.

*JOHNS-MANVILLE Sales Corp., 116 New Montgomery Street, San Francisco.
WESTERN ASBESTOS Co., 675 Townsend Street, San Francisco.

CRAMER Co., 50 Howard Street, San Francisco.

TURNER RESILIENT FLOORS, Inc., 141 New Montgomery Street, San Francisco.

CELOTEX Corp., 675 Townsend Street, San Francisco.

AIR CONDITIONING

S. T. JOHNSON Company, 940 Arlington, Oakland.

*ELECTRIC APPLIANCES, Inc., 2001 Van Ness Avenue, San Francisco.

ALADDIN HEATING Corporation, 2222 San Pablo Avenue, Oakland.

*FRANK EDWARDS Co. (General Electric), 930 Van Ness Avenue, San Francisco.

GENERAL Air Conditioning & Heating Company, 4001 Piedmont Avenue, Oakland.

ARCHITECTURAL METAL SUPPLIES

*BRAUN-STEEPLE Co., 636 Potrero Ave., San Francisco.

ARCHITECTURAL TERRA COTTA

N. CLARK & SONS, 116 Natoma Street, San Francisco.

GLADDING McBEAN & Co., 9th and Harrison Streets, San Francisco; 2901 Los Feliz Boulevard, Los Angeles; 1500 First Avenue South, Seattle; 79 S. E. Taylor Street, Portland; 22nd and Market Streets, Oakland; 1101 N. Monroe Street, Spokane; Vancouver, B.C.

KRAFTILE Company, Niles, California, and 525 Market Street, San Francisco.

BATHROOM HEATERS

WEXIX ELECTRIC Heater Company, 390 First Street, San Francisco; 631 San Julian Street, Los Angeles; 2008 Third Avenue, Seattle, Wash.

BLINDS—VENETIAN

GUNN-CARLE & Co., 20 Potrero Avenue, San Francisco.

*H. E. ROOT, 1865 California Street, San Francisco.

*RY-LOCK Co., 1355 Market Street, San Francisco.

BOILERS AND PIPE

*C. C. MOORE & Company, 450 Mission Street, San Francisco.

BRICK—FACE, COMMON, ETC.

N. CLARK & SONS, 116 Natoma Street, San Francisco.

GLADDING McBEAN & Co., 9th and Harrison Streets, San Francisco; 2901 Los Feliz Boulevard, Los Angeles; 1500 First Avenue, South, Seattle; 79 S.E. Taylor Street, Portland; 22nd and Market Streets, Oakland; 1102 N. Monroe Street, Spokane; Vancouver, B.C.

BRASS

AMERICAN BRASS Co., Russ Building, San Francisco.

BUILDERS HARDWARE

THE STANLEY WORKS, New Britain, Conn.; Monadnock Bldg., San Francisco; Los Angeles and Seattle.

*SCHLAGE LOCK Co., 20 Blanken Avenue, San Francisco.

*FARMER'S UNION, 151 W. Santa Clara Street, San Jose.

*MAXWELL HARDWARE Company, 1320 Washington Street, Oakland.

*P. and F. CORBIN, New Britain, Conn.

BUILDING MATERIALS

BUILDING MATERIAL EXHIBIT, Architect's Building, Los Angeles.

*MELROSE BUILDING MATERIAL CO., 4501 Tidewater Avenue, Oakland.

*CONTRA COSTA BUILDING MATERIALS Company, 2824 Shattuck Ave., Berkeley.

*MISSION BUILDING MATERIALS Co., Millbrae, Calif.

*RHODES & KENNEDY, 101 4th Street, Oakland.

BUILDING PAPERS

THE SISALKRAFT Company, 205 W. Wacker Drive, Chicago, Ill., and 55 New Montgomery Street, San Francisco.

BUILDING PRODUCTS

"BASALITE," a lightweight, pre-fabricated material for floors, walls and roofs—Basalt Rock Co., Inc., Napa, California.

CABINET WORK

*FINK and SCHINDLER, 552 Brennan Street, San Francisco.

MULLEN MANUFACTURING Co., 64 Rausch Street, San Francisco.

*MODERN FIXTURE & Cabinet Co., 59 Oak Grove Street, San Francisco.

CEMENT

*CALAVERAS CEMENT Company, 315 Montgomery Street, San Francisco.

PORTLAND CEMENT Association 564 Market Street, San Francisco; 816 West Fifth Street, Los Angeles; 146 West Fifth Street, Portland; 518 Exchange Building, Seattle.

"GOLDEN GATE" and "OLD MISSION" manufactured by Pacific Portland Cement Co., 111 Sutter Street, San Francisco; Portland, Los Angeles and San Diego.

*HENRY COWELL Lime & Cement Company, 2 Market Street, San Francisco.

*SANTA CRUZ PORTLAND Cement Company, Crocker Building, San Francisco.

CEMENT—COLOR

"GOLDEN GATE TAN CEMENT" manufactured by Pacific Portland Cement Co., 111 Sutter Street, San Francisco; Portland, Los Angeles and San Diego.

CEMENT PAINT

FRANK W. DUNNE Company, 41st and Linden Streets, Oakland.

CHEMICAL ENGINEERS

ABBOT A. HANKS, Inc., 624 Sacramento Street, San Francisco.

ROBERT W. HUNT, 251 Kearny Street, San Francisco.

CLAY PRODUCTS

GLADDING McBEAN & Company, San Francisco, Los Angeles, Portland and Seattle.

N. CLARK & SON, San Francisco and Los Angeles.

KRAFTILE Company, Niles, California, and 525 Market St., San Francisco.

*GLADDING BROS. Mfg. Co., San Jose.

CLOCKS—ELECTRIC TIME

*INTERNATIONAL BUSINESS Machines Corp., 25 Battery Street, San Francisco.

CONCRETE AGGREGATES

GOLDEN GATE ATLAS Material Company, Sixteenth and Harrison Streets, San Francisco.

JOHN CASSARETTO, Sixth and Channel Streets, San Francisco.

*TRANSIT CONCRETE, Inc., 2500 Peralta Street, Oakland.

CONCRETE CURING & PROTECTION

THE SISALKRAFT Company, 205 W. Wacker Drive, Chicago, Ill., and 55 New Montgomery Street, San Francisco.

CONCRETE JOIST CONSTRUCTION

CONCRETE REINFORCING INSTITUTE (Steel Form Contracting Company), Harrison Street, San Francisco.

CONTRACTORS—GENERAL

LINDGREN & SWINERTON, Inc., Standard Oil Building, San Francisco.

DINWIDDIE CONSTRUCTION Co., Crocker Building, San Francisco.

LOUIS C. DUNN, INC., Monadnock Building, San Francisco.

EMPIRE CONSTRUCTION COMPANY, LTD., Russ Building, San Francisco.

CLINTON CONSTRUCTION Company, 923 Folsom Street, San Francisco.

ANDERSON & RINGROSE, 320 Market Street, San Francisco.

G. P. W. JENSEN, 320 Market Street, San Francisco.

*GEO. ARTHUR & SON, 941 So. Claremont Street, San Mateo.

*A. T. BECKETT, 224 Scenic Avenue, Piedmont.

*L. M. G. PETERSON, 520 Bowdoin Street, Palo Alto.

*BARRETT & HILP, 918 Harrison Street, San Francisco.

DAMP-PROOFING & WATERPROOFING
"GOLDEN GATE TAN PLASTIC Waterproof Cement," manufactured by Pacific Portland Cement Co., 111 Sutter Street, San Francisco; Portland, Los Angeles and San Diego.

DOOR HANGERS

PITCHER'S SLIDING DOOR HANGERS Sheldon Building, San Francisco.

DOORS—HOLLOW METAL

FORDERER CORNICE Works, Potrero Avenue, San Francisco.

KAWNEER Mfg. Co., Eighth Street and Dwight Way, Berkeley.

ACID PROOF DRAIN PIPE

CORROSION—Acid resisting pipe, fittings exhaust fans, pumps, etc., Pacific Foundry Co., 3100 19th Street, San Francisco; 1400 S. Alameda Street, Los Angeles.

DRINKING FOUNTAINS

HAWS DRINKING FAUCET Co., 1808 Harmon Street, Berkeley.

ELECTRIC ADVICE

PACIFIC COAST ELECTRICAL Bureau, 447 Sutter Street, San Francisco, and 601 W. Fifth Street, Los Angeles.

ELECTRIC FIXTURES

*THE FRINK Corporation, 557 Market Street, San Francisco.

ELECTRICAL CONTRACTORS

*ALTA ELECTRIC and Mechanical Company 467 O'Farrell Street, San Francisco

ELECTRICAL EQUIPMENT—SUPPLIES
*TRUMBULL ELECTRIC Mfg. Co., 260 Van Ness Avenue, San Francisco.

*GENERAL ELECTRIC Supply Corp., 1201 Bryant Street, San Francisco.

*NATIONAL ELECTRIC Products Co., 400 Potrero Avenue, San Francisco.

*WESTINGHOUSE ELECTRIC & Mfg. Co., 1 Montgomery Street, San Francisco.

ELEVATORS

*WESTINGHOUSE ELECTRIC Elevator Company, 1 Montgomery Street, San Francisco.

*OTIS ELEVATOR Company, Beach Street, San Francisco.

ENAMELING—PORCELAIN

FERRO ENAMELING Company, 1100 57th Street, Oakland.

FLOORING

ASPHALT TILE, Western Asbestos Company, 675 Townsend Street, San Francisco.

*JOHNS-MANVILLE Sales Corp., 116 New Montgomery Street, San Francisco.

MAPLE FLOORING MANUFACTURERS ASSOCIATION, McCormick Building, Chicago. Ask your lumber dealer.

LE ROY OLSON COMPANY, 3070 - 17th Street, San Francisco.

*LILLY & CROWLEY, 123 Kansas Street, San Francisco.

FIXTURES—BANK, OFFICE, STORE

MULLEN MANUFACTURING Co., 64 Rausch Street, San Francisco.

ARCHITECTS' AND ENGINEERS' SPECIFICATION INDEX

Classified Directory of Building Material Manufacturers, Dealers and Contractors

*Denotes subscribers of ARCHITECTS' REPORTS, sponsored and endorsed by State Association of California Architects, and published daily by THE ARCHITECT AND ENGINEER. Other firms listed are regular advertisers, in addition to Reports.

PACIFIC MANUFACTURING Company,
454 Montgomery Street, San Francisco,
1315 Seventh Street, Oakland, Los Angeles and Santa Clara.

FURNITURE

***ALLIED ART GUILD,** Menlo Park.
***PENN. FURNITURE Shops, Inc.,** 130 Second Avenue, San Mateo.

GAS BURNERS

VAUGHN-G. E. WITT Company, 4224-26 Hollis Street, Emeryville, Oakland.

GLASS

W. P. FULLER & Co., 301 Mission Street, San Francisco. Branches and dealers throughout the West.

LIBBEY-OWENS-FORD GLASS Co., Toledo, Ohio; 633 Rialto Building, San Francisco; 1212 Architect's Building, Los Angeles; 550 Skinner Building, Seattle.

PITTSBURGH PLATE GLASS Company, Grant Building, Pittsburgh, Pa. W. P. Fuller & Co., Pacific Coast Distributors.

***L. H. BUTCHER COMPANY,** Fifteenth and Vermont Sts., San Francisco.

***EAST BAY GLASS Company,** 621 Sixth Street, Oakland.

***COBBLECK-KIBBE GLASS Company,** San Francisco, Oakland and San Jose.

HEATING—ELECTRIC

WESIX ELECTRIC Heater Company, 390 First Street, San Francisco; 631 San Julian Street, Los Angeles; 2008 Third Avenue, Seattle, Wash.

HEATING—GAS

***ALADDIN HEATING Corp.,** 22d and San Pablo Avenue, Oakland.

DAY and NIGHT WATER HEATER Company, Monrovia, California.

GENERAL Air Conditioning & Heating Company, 4001 Piedmont Avenue, Oakland.

HARER-PERRY Co., 5662 Keith Avenue, Oakland.

PACIFIC GAS & ELECTRIC Co., 245 Market Street, San Francisco.

HEATING—OIL

S. T. JOHNSON Company, 940 Arlington, Oakland.

HEAT GENERATORS

***WATROLO CORPORATION, LTD.,** 1170 Howard Street, San Francisco.

HEATING & VENTILATING EQUIPMENT

***AMERICAN RADIATOR Company,** 4th and Townsend Streets, San Francisco.

HEAT REGULATION

JOHNSON SERVICE Company, Milwaukee, represented on the Pacific Coast by the following branch offices: 814 Rialto Bldg., San Francisco; 153 West Avenue, 34, Los Angeles; 1312 N.W. Raleigh Street, Portland, and 473 Coleman Bldg., Seattle.

HOLLOW BUILDING TILE (Burned Clay)
N. CLARK & SONS, 116 Natoma Street, San Francisco.

GLADDING McBEAN & Co., 9th and Harrison Streets, San Francisco; 2901 Los Feliz Boulevard, Los Angeles; 1500 First Avenue South, Seattle; 79 S.E. Taylor Street, Portland; 22nd and Market Street, Oakland; 1102 N. Monroe Street, Spokane; Vancouver, B.C.

KRAFTILE Company, Niles, California, and 525 Market Street, San Francisco.

HOTEL and RESTAURANT EQUIPMENT

***DOHRMANN HOTEL SUPPLY Company,** 973 Mission Street, San Francisco.

INSPECTION AND TESTS

ABBOT A. HANKS, Inc., 624 Sacramento Street, San Francisco.

ROBERT W. HUNT Co., 251 Kearny Street, San Francisco.

INSULATION

CELOTEX Corp., 675 Townsend Street, San Francisco.

***JOHNS-MANVILLE Sales Corp.,** 116 New Montgomery Street, San Francisco.

WESTERN ASBESTOS Co., 675 Townsend Street, San Francisco.

CABOT'S QUILT—Gunn, Carle & Co., 20 Potrero Avenue, San Francisco.

VAPORSEAL, Mfg. by Celotex Corp., 919 N. Michigan Avenue, Chicago.

FIRTEX of Northern California, 461 Market Street, San Francisco.

***GEORGE D. KARSCH, Builders Exchange,** Sacramento, California.

INSURANCE

***FIREMAN'S FUND Insurance Company,** 401 California Street, San Francisco.

INTERIOR DECORATORS

***REED DRAPERY SERVICE,** 440 Post Street, San Francisco.

***M. H. WALES,** 1933 Laguna Street, San Francisco.

***BETTY KENDALL,** 251 Post Street, San Francisco.

KITCHEN EQUIPMENT

***MANGRUM, HOLBROOK & ELKUS,** 301 Golden Gate Avenue, San Francisco.

DOHRMANN HOTEL SUPPLY CO., 972 Mission Street, San Francisco.

LACQUERS

W. P. FULLER & Co., 301 Mission Street, San Francisco. Branches and dealers throughout the West.

LIGHTING FIXTURES

***W. W. WARREN Company,** 955 Mission Street, San Francisco.

***INCANDESCENT SUPPLY Company,** 726 Mission Street, San Francisco.

***PHOENIX-DAY Company,** 729 Mission Street, San Francisco.

LIMESTONE

***INDIANA LIMESTONE Company,** 130 Lunado Way, San Francisco.

LINOLEUM, CARPETS, Etc.

***WEST COAST LINOLEUM & CARPET Co.,** 1163 Market Street.

***VAN FLEET-FREEAR Company,** 557 Howard Street, San Francisco.

TURNER RESILIENT FLOORS, Inc., 141 New Montgomery Street, San Francisco.

***D. N. & E. WALTER & Company,** 562 Mission Street, San Francisco.

***CONGOLEUM-NAIRN, Inc.,** 1355 Market Street, San Francisco.

LOCKERS—METAL

***TRASK & SQUIER,** 39 Natoma Street, San Francisco.

LUMBER

PACIFIC MFG. Co., 454 Montgomery Street, San Francisco; 1315 Seventh Street, Oakland; Los Angeles and Santa Clara.

SMITH LUMBER Company, Nineteenth Avenue and Estuary, Oakland.

MELROSE LUMBER & SUPPLY Co., Forty-sixth Avenue and E. Twelfth Street, Oakland.

E. K. WOOD LUMBER Company, 470 Santa Fe Avenue, Los Angeles; 1 Drumm Street, San Francisco; Frederick and King Streets, Oakland.

***SANTA FE LUMBER Company,** 16 California Street, San Francisco.

***FRIEND & TERRY LUMBER Co.,** Front & S Streets, Sacramento.

***OAKLAND LUMBER Co.,** 6901 E. 14th Street, Oakland.

MACHINERY—PUMPS, Etc.

SIMONDS MACHINE COMPANY, 816 Folsom Street, San Francisco.

MARBLE

JOSEPH MUSTO SONS-KEENAN Co., 535 N. Point Street, San Francisco.

MILLWORK

E. K. WOOD LUMBER Company, No. 1 Drumm Street, San Francisco, Oakland and Los Angeles.

LANNOM BROS. Mfg. Co., Fifth and Magnolia Streets, Oakland.

MELROSE LUMBER & SUPPLY Company, Forty-sixth Avenue and E. Twelfth Street, Oakland.

PACIFIC MFG. Co., 454 Montgomery Street, San Francisco; 1315 Seventh Street, Oakland; Los Angeles and Santa Clara.

SMITH LUMBER Company, Nineteenth Avenue and Estuary, Oakland.

***WESTERN DOOR and SASH Company,** 5th and Cypress Streets, Oakland.

***OAKLAND PLANING MILL,** 105 Washington Street, Oakland.

***T. P. HOGAN Company,** 2d and Alice Streets, Oakland; 630 Mission Street, San Francisco.

***SAN MATEO PLANING MILL,** San Mateo.

MONEL METAL

"INCO" BRAND, distributed on the Pacific Coast by the Pacific Metals Company 3100-19th Street, San Francisco, and 1400 So. Alameda Street, Los Angeles.

***WHITEHEAD METAL APPLIANCE CO.,** 4238 Broadway, Oakland.

NURSERY STOCK

***C. J. BURR,** 305 Lytton Avenue, Palo Alto.

***CALIFORNIA NURSERIES,** Niles.

OIL BURNERS

***SAN MATEO FEED and FUEL Company,** San Mateo, Cal.

S. T. JOHNSON Co., 585 Potrero Avenue, San Francisco; 940 Arlington Street, Oakland; 1729 Front Street, Sacramento, and 1020 El Camino Real, San Carlos, Calif.

VAUGHN-G. E. WITT Co., 4224-26 Hollis Street, Emeryville, Oakland.

***HORABIN OIL & BURNER Company,** 234 Hamilton Avenue, Palo Alto.

PAN-AMERICAN SIMPLEX OIL BURNER, 820 Parker Street, Berkeley.

ONIX

JOSEPH MUSTO SONS-KEENAN Co., 535 No. Point Street, San Francisco.

ORNAMENTAL IRON

INDEPENDENT IRON WORKS, 821 Pine Street, Oakland.

PAINTING, DECORATING, Etc.

THE TORMEY Co., 563 Fulton Street, San Francisco.

***RAPHAEL Company,** 270 Tehama Street, San Francisco.

PAINTS, OIL, LEAD

W. P. FULLER & CO., 301 Mission Street, San Francisco. Branches and dealers throughout the West.

FRANK W. DUNNE Co., 41st and Linden Streets, Oakland.

NATIONAL LEAD Company, 2240-24th Street, San Francisco. Branch dealers in principal Coast cities.

***SHERWIN-WILLIAMS Company,** 1415 Sherwin Avenue, Oakland.

***WALTER N. BOYSEN PAINT CO.,** 42nd and Linden Street, Oakland

PARTITIONS—MOVABLE OFFICE

PACIFIC MFG. Co., 454 Montgomery Street, San Francisco; 1315 Seventh Street, Oakland; factory at Santa Clara.

PLASTER

"EMPIRE" and "RENO HARDWALL PLASTER," manufactured by Pacific Portland Cement Co., 111 Sutter Street, San Francisco; Portland, Los Angeles and San Diego.

THE ARCHITECT AND ENGINEER

ARCHITECTS' AND ENGINEERS' SPECIFICATION INDEX

Classified Directory of Building Material Manufacturers, Dealers and Contractors

*Denotes subscribers of ARCHITECTS' REPORTS, sponsored and endorsed by State Association of California Architects, and published daily by THE ARCHITECT AND ENGINEER. Other firms listed are regular advertisers, in addition to Reports.

PLASTERING CONTRACTOR

*JAMES F. SMITH, 271 Minna Street, San Francisco.

PLASTER—ACOUSTICAL

CALACOSTIC, Sound Absorbing Plaster, manufactured by Pacific Portland Cement Co., 111 Sutter Street, San Francisco, Los Angeles and San Diego.

PLASTER MATERIALS

*U. S. GYPSUM Company, Architect's Building, Los Angeles.

PLATE GLASS

LIBBEY-OWENS-FORD GLASS Co., Toledo, Ohio; 633 Rialto Building, San Francisco; 1212 Architect's Building, Los Angeles; Mr. C. W. Holland, P.O. Box 3142, Seattle.

PLUMBING CONTRACTORS

CARL T. DOELL, 467-21st Street, Oakland.

*SCOTT Company, 243 Minna Street, San Francisco.

*W. H. PICARD, 4166 Broadway, Oakland.

PLUMBING FIXTURES AND SUPPLIES

CRANE Co., all principal Coast cities.
*STANDARD SANITARY Manufacturing Company, 278 Post Street, San Francisco.
*WALWORTH CALIFORNIA Company, 665 Sixth Street, San Francisco.
*W. R. AMES Co., 150 Hooper Street, San Francisco.
TAY-HOLBROOK, Inc., 165 Eighth Street, San Francisco.

PRESSURE REGULATORS

VAUGHN-G. E. WITT Co., 4224-28 Hollis Street, Emeryville, Oakland.

PUMPS

SIMONDS MACHINERY Company, 816 Folsom Street, San Francisco.

REFRIGERATION

DELCO-FRIGIDAIRE ELECTRIC REFRIGERATORS, Aladdin Heating Corp., 22d and Broadway, Oakland.

ROOFING CONTRACTORS

*MALLOTT & PETERSON, 2412 Harrison Street, San Francisco.

ROOFING INSULATION

*JOHNS-MANVILLE Sales Corp., 116 New Montgomery Street, San Francisco.

ROOF MATERIALS

*JOHNS-MANVILLE Sales Corp., 116 New Montgomery Street, San Francisco.
*PIONEER FLINTKOTE Company, Shell Building, San Francisco.
*PARAFFINE Company, Inc., 475 Brannan Street, San Francisco.
GLADDING McBEAN & Co., 9th and Harrison Streets, San Francisco; 2901 Los Feliz Boulevard, Los Angeles; 1500 First Avenue South, Seattle; 79 S.E. Taylor Street, Portland; 22nd and Market Street, Oakland; 1102 N. Monroe Street, Spokane; Vancouver, B.C.
*MARSHALL SHINGLE Company, 608-16th Street, Oakland.
N. CLARK & SONS, 112-116 Natoma Street, San Francisco; works, West Alameda.
*CERTAIN-TEED PRODUCTS Co., 315 Montgomery Street, San Francisco.

SAFES

HERRING-HALL-MARVIN SAFE Co., 214 California Street, San Francisco.

SAND, ROCK AND GRAVEL

JOHN CASSARETTO, Sixth and Channel Streets, San Francisco.

BASALT ROCK Co., Napa.

*KAISER PAVING Company, Latham Square Building, Oakland.

MELROSE BUILDING MATERIAL Co., 4501 Tidewater Avenue, Oakland.

SEATING

*HEYWOOD-WAKEFIELD Co., 180 New Montgomery Street, San Francisco.

*GENERAL SEATING Company, 160 Second Street, San Francisco.

SHADE CLOTH

CALIFORNIA SHADE CLOTH Co., 210 Bayshore Boulevard, San Francisco.

SHINGLE STAINS

CABOT'S CREOSOTE STAINS, Gunn-Carle & Co., 20 Potrero Ave., San Francisco.

AUTO SPRINKLERS

GLOBE AUTOMATIC SPRINKLER Co., 665-6th Street, San Francisco.

STANDARD STEEL BUILDINGS

INDEPENDENT IRON WORKS, 821 Pine Street, Oakland.

STEEL FURNITURE

*GENERAL FIREPROOFING Company, 160 Second Street, San Francisco.

STEEL—REINFORCING

*SOULE STEEL Company, Army Street, San Francisco and Los Angeles.

GUNN-CARLE Company, Potrero Avenue, San Francisco.

CECO STEEL PRODUCTS Co., 1280 Indiana Street, San Francisco.

*W. C. HAUCK & Co., 280 San Bruno Avenue, San Francisco.

*TRUSCON STEEL Company, 604 Mission Street, San Francisco.

STEEL—STAINLESS

REPUBLIC STEEL Corporation, Rialto Building, San Francisco; Edison Building, Los Angeles; White-Henry-Stuart Building, Seattle.

STEEL—STRUCTURAL

INDEPENDENT IRON WORKS, 821 Pine Street, Oakland.

JUDSON PACIFIC Company, C. F. Weber Building, Mission and Second Streets; San Francisco shops, San Francisco and Oakland.

HERRICK IRON WORKS, 18th and Campbell Streets, Oakland.

*MOORE DRYDOCK Company, Foot of Adeline Street, Oakland.

*WESTERN IRON WORKS, 141 Beale Street, San Francisco.

COLUMBIA STEEL Company, Russ Building, San Francisco.

STORE FIXTURES

MULLEN MFG. Co., 60 Rausch Street, San Francisco.

STORE FRONTS

ZORI STORE FRONTS, Niles, Michigan.
KAWNEER MFG. Co., Eighth Street and Dwight Way, Berkeley.

STUCCO NETTING—WELDED

"WELDWEAVE," E. H. EDWARDS Co., 200 Bush Street, San Francisco; 620 E. 61st Street, Los Angeles; 1252 6th Avenue S., Seattle; 2690 N.W. Nicolai Street, Portland.

TEMPERATURE REGULATION

JOHNSON SERVICE Company, Milwaukee, represented on the Pacific Coast by the following branch offices: 814 Rialto Building, San Francisco; 153 West Avenue 34, Los Angeles; 1312 N.W. Raleigh Street, Portland, and 473 Coleman Building, Seattle.

TELEPHONES—INTERCOMMUNICATING

*PACIFIC TELEPHONE and TELEGRAPH Company, 140 New Montgomery Street, San Francisco.

TERMITE CONTROL—WOOD PRESERVATIVE

E. K. WOOD LUMBER Company, No. 1 Drumm Street, San Francisco; 4701 Santa Fe Avenue, Los Angeles; Frederick and King Streets, Oakland.

J. H. BAXTER & COMPANY, 333 Montgomery Street, San Francisco.

TILE—DECORATIVE, Etc.

*CAMBRIDGE TILE Mfg. Co., 1155 Harrison Street, San Francisco.

POMONA TILE MFG. Co., plant, Pomona, Cal.; Sales Rooms, 135 Tenth Street, San Francisco; 217 S. La Brea Avenue, Los Angeles; 6106 Roosevelt Way, Seattle.

GLADDING McBEAN & Co., 9th and Harrison Streets, San Francisco; 2901 Los Feliz Boulevard, Los Angeles.

KRAFTILE Company, Niles California, and 525 Market St., San Francisco.

*CALIFORNIA ART TILE Corp., Richmond, Cal.

TREE SURGERY

DAVEY TREE SURGERY Co., Ltd., Russ Building, San Francisco; Story Building, Los Angeles.

TRUSSES

*SUMMERBELL TRUSS Company, 405 Builders Exchange Building, Oakland.

*ARCH-RIB TRUSS Company, 608 Sixteenth Street, Oakland.

VALVES

"KRAMER" Flush Valves, MacDonald Hardware Manufacturing Co., 963 Harrison Street, San Francisco.

SLOAN VALVE Company, Chicago, Ill.

SHAND AND JURS Co., Eighth and Carlton Streets, Berkeley.

VARNISHES

NATIONAL LEAD Company, 2240-24th Street, San Francisco. Branches and dealers in all principal Coast cities.

W. P. FULLER Company, San Francisco and principal Coast cities.

FRANK W. DUNNE Co., 41st and Linden Streets, Oakland.

VAULTS AND SAFES

HERMANN SAFE Company, 200 Howard Street, San Francisco.

VENTILATING EQUIPMENT

*THE B. F. STURTEVANT Company, 759 Monadnock Building, San Francisco.

WALL BOARD

*WESTERN BUILDERS SUPPLY Company, 401 Fourth Street, San Francisco.

WATER HEATERS—GAS AND ELECTRIC DAY and NIGHT WATER HEATER Company, Monrovia, California.

*WATROLA Corporation, Ltd., 1170 Howard Street, San Francisco.

*PITTSBURGH WATER HEATER Co., 898 Van Ness Avenue, San Francisco.

*RUUD HEATER Company, 437 Sutter Street, San Francisco.

WESIX ELECTRIC HEATER Company, 380 First Street, San Francisco.

WINDOW SASH AND FIXTURES

"DALMO," SIMPLEX and "HAUSER" Casement Windows, MacDonald Hardware Mfg. Co., 963 Harrison Street, San Francisco.

*DETROIT STEEL PRODUCTS Co., 111 Sutter Street, San Francisco.

KAWNEER MFG. Company, Dwight Way and Eighth Street, Berkeley.

UNIVERSAL WINDOW COMPANY, (Donovan) 950 Parker Street, Berkeley.

WINDOW SHADES

AEROSHADE Company, represented by W. R. Knight, 557 Market Street, San Francisco.

CALIFORNIA SHADE CLOTH Co., 210 Bayshore Boulevard, San Francisco.

INDEX TO ADVERTISEMENTS

*Indicates Alternate Months

A		K	
ALADDIN Heating Corporation	65	KAWNEER Company	3
AMERICAN Brass Company	12A	KRAFTILE Company	73
ANDERSON & Ringrose	74	L	
ARCHITECTS Building	70	LANNOM Bros. Manufacturing Company	74
B		LAUCKS, F., Inc.	12
BASALT Rock Company	71	LIBBEY, Owens, Ford Glass Company	5
BAXTER & Company, J. H.	68	LINDGREN & Swinerton, Inc.	69
BUILDING Material Exhibit	70	M	
C		M. & M. Woodworking Company	65
CASSARETTO, John	76	MacDONALD Hardware Manufacturing Company	67
CELOTEX Corporation	*	MAPLE Flooring Manufacturers Association	9
CLARK, N., and Sons	3d Cover	MISSION Inn	68
CLINTON Construction Company	74	MULLEN Manufacturing Company	75
CONCRETE Reinforcing Steel Institute	*	MUSTO Sons Keenan Company, Joseph	75
CRANE Company	*	N	
CROCKER First National Bank	74	NATIONAL Lead Company	12
CROCKER, H. S., CO., INC.	76	O	
D		OREGON-Washington Plywood Company	6
DAVEY Tree Surgery Company	71	P	
DAY and Night Water Heater Company	62	PACIFIC Coast Gas Association	11
DELCO-FRIGIDAIRE	65	PACIFIC Coast Electrical Bureau	66
DINWIDDIE Construction Company	75	PACIFIC Foundry Company, Ltd.	69
DOELL, Carl T., Company	75	PACIFIC Manufacturing Company	72
DOUGLAS Fir Plywood Association	2d Cover	PACIFIC Portland Cement Company	*
DUNNE Company, Frank W.	74	PITCHER Company, E. C.	74
E		PITTSBURGH Plate Glass Company	*
EMPIRE Construction Company	74	POMONA Tile Manufacturing Company	70
F		PORTLAND Cement Association	Back Cover
FERRO-PORCELAIN Building Company	75	R	
FORDERER Cornice Works	73	REPUBLIC Steel Corporation	76
FULLER Company, W. P.	*	S	
G		SANTA Maria Inn	76
GLADDING, McBean & Company	*	SIMONDS Machinery Company	72
GOLDEN Gate Atlas Materials Company	72	SISALKRAFT Company	72
GUNN, Carle & Company	73	SLOAN Valve Company	13A
H		SMITH Lumber Company	75
HANKS, Inc., Abbot A.	76	STANLEY Works	*
HARER-Perry Company	70	T	
HARBOR Plywood Corporation	7	TORMEY Company, The	76
HAWS Drinking Faucet Company	72	U	
HERMANN Safe Company	76	UNIVERSAL Window Company	72
HERRICK Iron Works	73	V	
HOTEL CLARK	74	VAUGHAN-G. S. Witt Company	76
HUNT, Robert W. Company	76	W	
HUNTER and Hudson	76	WASHINGTON Veneer Company	10
I		WESIX Electric Heater Company	73
INCANDESCENT Supply Company	70	WILCOX, Roy F., Company	68
INDEPENDENT Iron Works	74	WOOD, E. K., Company	67
J		WHEELER Osgood Sales Corporation	8
JENSEN & Son, G. P. W.	75	WESTERN Asbestos Company	71
JOHNSON, S. T., Company	62	Z	
JOHNSON Service Company	5	ZOURI Store Fronts	*
JUDSON Pacific Company	71		

