

ART MAGAZINE

OVERSIZE X 5



BOOK NO.

ACCESSION

720.5 Ar24 64

162542

NOT TO BE TAKEN FROM THE LIBRARY

FORM NO. 37 2M-5-21

C



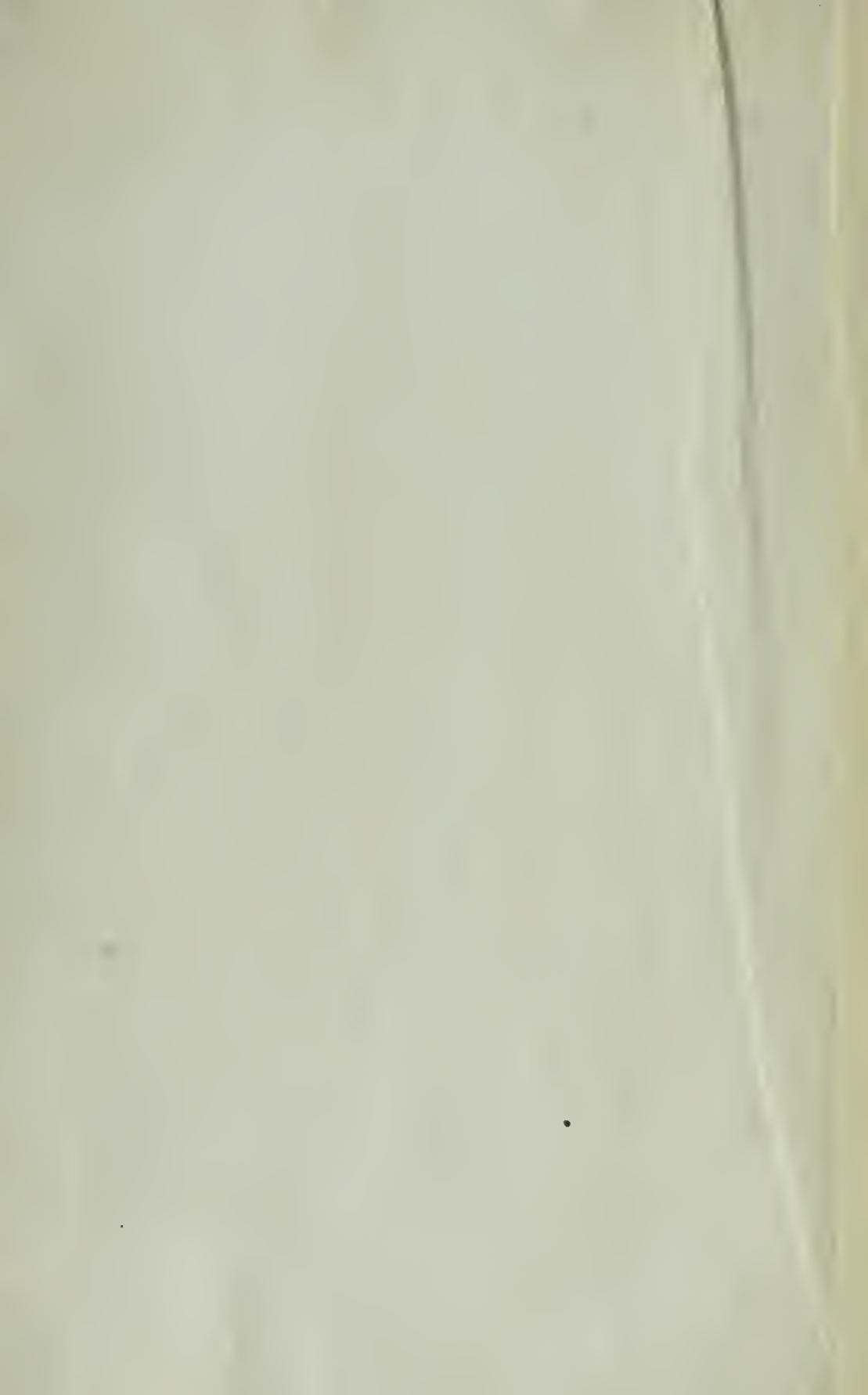

THE UNIVERSITY OF CALIFORNIA
LIBRARY

The ARCHITECT & ENGINEER



JANUARY 1921

*Published in San Francisco
35 cents a copy - \$2⁵⁰ a year*



Your clients can secure
no higher quality than
PACIFIC
PLUMBING FIXTURES



M. Hoxie

MAIN OFFICES: 67 NEW MONTGOMERY ST., SAN FRANCISCO; FACTORIES: RICHMOND
AND SAN PABLO, CALIFORNIA



*Pacific Nash Motor Company's New Building,
San Francisco
Covered with a PABCO 10-Year Roof*

Howard Schultz,
Architect
McDonald & Kahn, Engineers.
Managers of Construction
Alta Roofing Co.,
Roofing Contractors

LASTING ROOFS

PABCO Roofs are well known on the "Automobile Rows" of Pacific Coast Cities. The reason is plain. Not only the splendid buildings, but the valuable stock of motor cars, parts, and equipment must be absolutely protected against the elements by a proved roof.

PABCO 10 and 20-Year Roofs

Are guaranteed for the periods specified because they have fully demonstrated their worth after years of service under the most severe weather conditions in all climates.

Write for Specifications

THE PARAFFINE COMPANIES, Inc.
San Francisco



Roofings, Felts
Building Papers
Wall-Board
Floor Covering
Waterproofing
Materials
Roof Coatings
Industrial and Marine
Paints
Electrical Varnishes
and Insulating
Compounds
Box-Board
Paper-Boxes

STEEL BARS

FOR
CONCRETE REINFORCEMENT

CORRUGATED
TWISTED
SQUARES
OR
ROUNDS
CUT
TO
LENGTH



FABRICATED
AND
INSTALLED
LUMP SUM
BIDS
ON
WORK
COMPLETE

Office, 444 MARKET STREET
Warehouse, 10th and Bryant Streets
Phone: Sutter 2720

"HYDRATITE" FOR WATERPROOFING AND HARDENING CONCRETE "HORNSTONE"

Look for this
Trademark



And if it's there don't worry
any more about your
Valves and Fittings

*Specify and
insist upon
having*

The Kelly & Jones Co.
Valves and Fittings

Byers Genuine
Wrought Iron Pipe

Republic Steel Pipe

Complete Line of Plumbing Supplies
Large Stocks for Prompt Delivery
Catalogue on request

**California Steam &
Plumbing Supply Co.**

671-679 Fifth Street, Corner Bluxome
SAN FRANCISCO, CALIFORNIA





Lights for the home-to-be

Elexits



"Places for Lights"

SILVER SCONCES for the dainty white colonial living room that is so soon to be hers! And the charm of changeable lighting that they embody! For the many "places for lights" in the cozy little home mean a new freedom for experimentation and change in decoration and arrangement.

ELECTRIC OUTLET COMPANY

Inc.

119 West 40th St., New York City

This picture enlarged on heavy mat paper with caption, furnished ready for framing upon receipt of \$5.00. Send check with order.

When writing to Advertisers please mention this magazine.

W. & J. SLOANE



Carpetings Furniture
Rugs
Linoleum Window Shades
Wall Papers
Interior Decorations

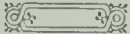

216-228 Sutter Street

Tel. Garfield 2838 San Francisco

TIME CLOCKS

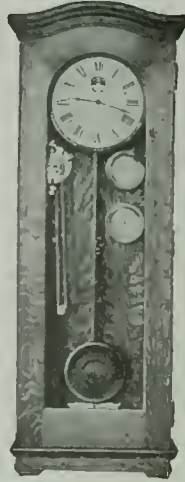

SCHOOLS must have uniform time to secure efficient results. They also need automatic sounding of the program Bells synchronized with the clocks.

All "Standard" Electric Time Equipments are guaranteed against any electrical or mechanical defects for a period of one year from date of installation. Specifications, blue prints and other information will be gladly furnished architects, engineers or officials for planning and installing "Standard" systems. Let us cooperate with you for securing the best results.

STANDARD ELECTRIC TIME COMPANY

461 MARKET STREET

Phune Sutter 241

SAN FRANCISCO

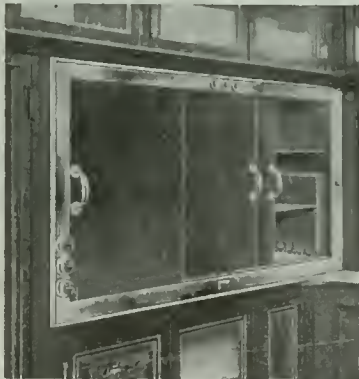

PROMETHEUS

The Electric Food and Plate Warmer

Wherever meals are cooked and served, in apartments, residences and institutions, Prometheus is a highly valued asset. The wireless heating units placed independently of the shelves keep food hot and tasty until ready to serve and cannot injure the finest china.

Write for information and list of installations

The Prometheus Electric Co.

Manufacturers

511 West 42d Street, New York

Showroom. **M. E. HAMMOND**
Mezzanine Floor Pacific Bldg., San Francisco

GLOW

Modern Heating

AS in lighting, the trend in heating is toward central station service. The wastefulness and high maintenance cost of individual heating plants is becoming understood by the public. At the same time gas — not as a supplementary but as the *main* source of heat—is being recognized. Architects, naturally in the forefront of all developments in such matters, ought to be thoroughly informed as to the scope and possibilities of the Gasteam Radiator. It is as revolutionary and far-reaching in its possibilities as concrete.

The subject is fully covered in our booklet. Let us send you a copy.

Frederick A. Hamilton

Sales Agent

Show Rooms:

RIALTO BUILDING
SAN FRANCISCO



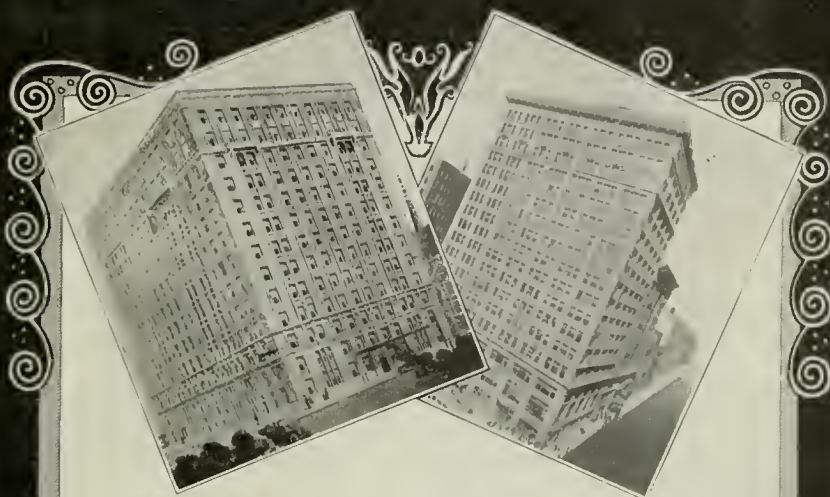

Performance *More Eloquent than Promises*

A FEW OF THE THOUSANDS OF "IDEAL"-
EQUIPPED BUILDINGS

Hotel Breton Hall.....	New York, N. Y.
Palace Theatre.....	New York, N. Y.
Prince George Hotel.....	New York, N. Y.
St. Anthony Hospital.....	Chicago, Ill.
Guger Building.....	Indianapolis, Ind.
Radison Hotel.....	Minneapolis, Minn.
Union Station.....	St. Paul, Minn.
Court House.....	Sioux City, Iowa.
Spaulding Hotel.....	Duluth, Minn.
First National Bank Building.....	Des Moines, Iowa.
Arlington Hotel.....	Washington, D. C.
Caheen Building.....	Birmingham, Ala.
Shawnee Hotel.....	Springfield, Ohio
Herald Building.....	Lexington, Kentucky
Big Four R. R. Office Building.....	Cincinnati, Ohio
Deleo Company Building.....	Dayton, Ohio
Union Trust Building.....	Cincinnati, Ohio
Farmers & Merchants National Bank.....	Stockton, Cal.

Do years of faithful service by "Ideal" Elevator Door Equipment installed in these representative buildings interest you in knowing more about "Ideal" hardware? If so, allow us to send you, without obligation, illustrated catalog A-21, "Ideal Elevator Door Equipment and Checking Devices."



The Door Hanger Institution

R-W "Ideal" Elevator Door Equipment

E. B. Noble, President
A. E. Wilkins, Vice-Pres.

Beam, Angle, Channels, and Universal Mill
Plates for immediate shipment from stock

Pacific Rolling Mill Co.

SUPPLIERS OF

FABRICATED STRUCTURAL STEEL, Forgings,
Bolts, Rivets, Frogs, Switches, Cast Iron Castings

General Office and Works
17th and MISSISSIPPI STS., SAN FRANCISCO
Telephone Market 215

Beams
Channels
Angles
Plates

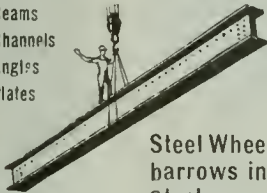

Steel Wheel-
barrows in
Stock

Western Iron Works

W. B. MORRIS, Pres. H. H. MORRIS, V.-P. L. J. GATES, Sec.

STRUCTURAL IRON AND
STEEL CONTRACTORS

141-147 Beale St. and 132-148 Main St. SAN FRANCISCO

Phones: GARFIELD 2575--2576

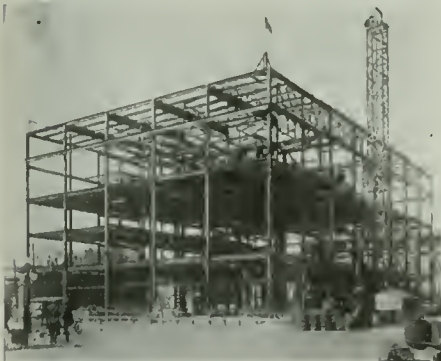

STEEL FRAME, MASONIC TEMPLE,
Sacramento. R. A. HEROLD, Architect.

STRUCTURAL STEEL
(600 tons) Fabricated and
Erected by

THE PALM IRON AND
BRIDGE WORKS (Incorporated)
15th and R Streets, Sacramento, Cal.

Cast Iron Stairs and Store Fronts

Bank and Office Railings, Elevator
Enclosures and Fire Escapes.

C. J. HILLARD CO., Inc.

Nineteenth and Minnesota Streets
Telephone Mission 1763

SAN FRANCISCO, CAL.

Architects' Specification Index

(For Index to Advertisements, see next page)

ARCHITECTURAL TERRA COTTA

Gladding, McBean & Company, Crocker Bldg.,
San Francisco.
Livermore Fire Brick Works, 604 Mission street,
San Francisco.

ASBESTOS ROOFING, PACKING, ETC.

H. H. Robertson Co., Hobart Bldg., San Francisco.
H. W. Johns-Manville Co., San Francisco, Los
Angeles and Portland, Ore.

AUTOMATIC SPRINKLERS

Grinnell Co. of the Pacific, 453 Mission St., San
Francisco.
Pacific Fire Extinguisher Co., 424 Howard St.,
San Francisco.

AUTOMOBILE INSURANCE

Bankers & Shippers Insurance Co. of New York,
Insurance Exchange Bldg., San Francisco.

AUTOMOBILES

W. L. Hughson Co., Geary St., at Van Ness Ave.,
San Francisco.

AWNINGS, TENTS, ETC.

W. A. Plummer, Front, at Pine St., San Fran-
cisco.

BANKS

First National Bank, Post and Montgomery
streets, San Francisco.

BANK FIXTURES AND INTERIORS

Fink & Schindler, 218 13th St., San Francisco.
C. F. Weber & Co., 985 Market St., San Fran-
cisco.

Home Mfg. Co., 543 Brannan St., San Fran-
cisco.

Mullen Manufacturing Co., 64 Rausch St., San
Francisco.

Rucker-Fuller Desk Co., 677 Mission St., San
Francisco.

Pacific Manufacturing Company, San Francisco,
Los Angeles, Oakland and Santa Clara.

BELTING AND PACKING

New York Belting and Packing Company, 519
Mission St., San Francisco.

H. N. Cook Belting Co., 401 Howard St., San
Francisco.

Smith-Booth-Usher Co., San Francisco and Los
Angeles.

BLACKBOARDS

C. F. Weber & Co., 985 Market St., San Fran-
cisco, Los Angeles and Reno, Nevada.

Beaver Blackboards and Greenboards, Rucker-
Fuller Desk Company, Coast agents, 677 Mis-
sion St., San Francisco; also Oakland and
Los Angeles.

BLINDS—VENETIAN AND DIFFUSELITE

J. G. Wilson Corporation, Metropolitan Bldg.,
Los Angeles; Waterhouse-Wilcox, Underwood
Bldg., San Francisco.

Western Venetian Blind Co., Long Beach Ave.,
Los Angeles; C. F. Weber & Co., San Fran-
cisco.

BOILERS

California Hydraulic Engineering & Supply Co.,
70-72 Fremont St., San Francisco.

Kewanee Water Supply System, Simonds Ma-
chinery Co., 117 New Montgomery St., San
Francisco.

General Boilers Co., 322 Monadnock Bldg., San
Francisco.

BOOK BINDERS

Abbott-Brady Printing Corp'n, 460 Fourth St.,
San Francisco.

H. S. Crocker Co., 565 Market St., San Fran-
cisco.

BONDS FOR CONTRACTORS

American Mutual Liability Insurance Co., Balboa
Bldg., San Francisco.

Bonding Company of America, Kohl Bldg., San
Francisco.

Bankers & Shippers Insurance Co. of New York,
Insurance Exchange Bldg., San Francisco.

Globe Indemnity Co., 120 Leidesdorff St., San
Francisco.

Fidelity & Casualty Co. of New York, Merchants
Exchange Bldg., San Francisco.

Fidelity & Deposit Co. of Maryland, Insurance
Exchange, San Francisco.

John H. Robertson, 621 First National Bank
Building, San Francisco.

National Surety Co. of New York, 105 Mont-
gomery St., San Francisco.

BRASS GOODS, CASTINGS, ETC.

H. Mueller Manufacturing Co., 635 Mission St.,
San Francisco.

BRICK, PRESSED, PAVING, ETC.

California Brick Company, 604 Mission street,
San Francisco.

Livermore Fire Brick Works, 604 Mission street,
San Francisco.

Los Angeles Pressed Brick Co., Frost Bldg., Los
Angeles.

United Materials Co., Crossley Bldg., San Fran-
cisco.

Cannon & Co., Sacramento; and Chronicle Bldg.,
San Francisco.

BRICK & CEMENT COATING

Armortite and Concreta, manufactured by W. P.
Fuller & Co., all principal Coast cities.

The Paraffine Companies, Inc., 34 First St., San
Francisco.

R. N. Nason & Co., 151 Potrero Ave., San
Angeles.

Wadsworth, Howland & Co., Inc., Boston, Mass.,
manufacturers of Bay State Brick & Cement

Coating. Hambley & Son, agents, San Fran-
cisco and Los Angeles.

BRICK STAINS

Samuel Cabot Mfg. Co., Boston, Mass., agencies
in San Francisco, Oakland, Los Angeles, Port-
land, Tacoma and Spokane.

Armortite and Concreta, manufactured by W. P.
Fuller & Co., all principal Coast cities.

BUILDERS' HARDWARE

Joost Bros., agents for Russell & Erwin Hard-
ware, 1053 Market St., San Francisco.

The Stanley Works, New Britain, Conn., repre-
sented in San Francisco and Los Angeles by

John Rountree & Co.

Palace Hardware Company, Agents Corbin goods,
581 Market St., San Francisco.

Richards-Wilcox Mfg. Co., Aurora; Ewing-Lewis
Co., 626 Underwood Bldg., San Francisco.

GRINNELL AUTOMATIC SPRINKLER GRINNELL COMPANY

OF THE PACIFIC

VALVES
PIPE and FITTINGS

ENGINEERS AND CONTRACTORS
453 Mission Street, San Francisco

CHEMICAL FIRE
EXTINGUISHERS
and FIRE ENGINES

An Index to the Advertisements

	Page		Page		Page
Abbott-Brady Printing Corp	151	Grinnell Co.	7	Paraffine Companies, Inc.	1
American Face Brick Ass'n.	127	Gunn Carle Company	2	Parker, K. E. Co., Inc.	144
American Insulex Co.	26	Haines, Jones & Cadbury	131	Perfected Mfg. Co.	36-37
American La France Fire Engine Co.	148	Hamilton, F. A.	4	Petrium Sanitary Sink Co.	111
American Mutual Liability Insurance Co.	10	Hammond, M. E.	4	Phillips, Chas. T.	145
American Mail Chute	32	Hannah, J. D.	142	Pitcher Door Hanger	33
American Marble & Mosaic Co.	44	Hauser Window Co.	26	Pittsburg Water Heater Co.	132
American Rolling Mill Co.	133	Haws Sanitary Drinking Faucet Co.	138	Plummer, W. A.	138
American Standard Oil Burner	43	Hillard, C. J., Co.	6	Pope & Talbot	15
American Window Glass Co.	42	Hill, Hubbell & Company	130	Portland Lumber Co.	15
Atlas Heating & Ventilating Co.	146	Holbrook, Merrill & Stetson	147	Portman, Frank	158
Bacon, Edward R., Co.	157	Home Mfg. Co.	158	Power Construction Company	136
Badt-Falk & Co.	145	Hoosier Store	123	Prometheus Electric Co.	4
Baird-Bailhache Company	24	Hughson, W. L. Co.	30	Raymond Granite Co.	152
Bankers' & Shippers' Ins. Co.	34	Hunt, Robt. W. & Co.	132	Redwood Manufacturers	42
Barrett & Hilp	144	Hunter & Hudson	140	Reliance-Grant Elevator Equipment Co.	22
Bartlett, John M.	136	Ideal Heating & Engineering Co.	146	Rex Electric Engineering Co.	155
Bass-Hueter Co.	3rd Cover	Illinois Engineering Co.	146	Richards Wilcox Mfg. Co.	5
Baxter, Reed	31	Imp Mfg. Co.	148	Ringius, John	136
Beach-Robinson Co.	31	Imperial Waterproofing	32	Roberts Mfg. Co.	159
Beckwith, Herbert	145	James & Drucker	146	Robertson Co., H. H.	11
Bowser & Co., S. F.	41	Jarvis, T. P. Mfg. Co.	43	Robertson, John H.	150
Breuner, John	132	Johns-Manville Co.	152	Ruegg Bros.	150
Briminstool Co.	22	Johnson, S. T.	43	Rucker-Fuller Desk Co.	140
Browie-Langlais Company	155	Johnson Service Co.	11	Ryan, M. B.	155
Butte Electrical Equipment Co.	154	Joost Brothers	140	Safety Electric Co.	154
Butte Electric & Mfg. Co.	155	Kawner Mfg. Co.	143	Sampson Spot Cord	136
Cabot, Samuel (Inc.)	41	Key-hold Plaster Lath Co.	32	San Francisco Pioneer Varnish Works	3d Cover
California Artistic Metal and Wire Co.	152	Kissel, I. R.	142	Scott Co.	146
California Bldg. Material Co.	150	Knittle-Cashel Co., Inc.	13	Schrader Iron Works	152
California Brick Co.	23	Knowles, A.	152	Schwabacher-Frey Co.	159
California Granite Co.	146	Lange & Bergstrom	122	Sloane, W. & J.	4
California Hydraulic Engineering and Supply Co.	10	Leiter, E. T. & Son	136	Simmons, O. M. Co.	12
California Paint Co.	14	Liberty Electric Co.	136	Simonds Machinery Co.	129
California Plastic Products Co.	137	Littlefield, R. W.	144	Smith-Booth-Usher Co.	157
California Redwood Ass'n.	153	Livermore Fire Brick Works	23	Smith, Jas. F.	144
California Steam and Plumbing Supply Co.	2	Los Angeles Pressed Brick Co.	28-29, 126	Sommer, I. M.	144
Cannon & Co.	121	MacGruer & Simpson	151	Sonneborn, L. Sons, Inc.	135
Cement Gun Construction Co.	122	MacRorie-McLaren Co.	153	Sonnenschein Bros.	31
Central Electric Co.	132	Magner Bros.	140	Spencer Elevator Co.	24
Central Iron Works	152	Mangrum & Otter	159	Spott Electrical Co.	156
Clow & Sons	4	Marshall & Stearns Co.	141	Standard Varnish Works	22
Cobbedick-Kibbe Glass Co.	136	McCray Refrigerator Co.	32	Standard Electric Time Co.	4
Coleman, Alex	146	McLaughlin, Jas. L.	158	Standard Fence Co.	145
Collman & Spreidl	142	McLeran & Peterson	150	Stanley Works, The	119
Coleman, Alex	146	McNab, H. N.	145	Steelform Contracting Co.	144
Collman & Spreidl	142	Medusa Cement	27	Steel Studing Co.	137
Cook Belting Co.	38	Meese & Gottfried	120	St. Francis Hotel	129
Cowell Lime & Cement Co.	143	Moline Heat	17	Stockholm, Chas. & Son	136
Crane Co.	153	Monite Range & Furnace Co.	18	Strable Hardwood Co.	148
Crocker, H. S. Co.	134	Monson Bros.	142	Sunset Lumber Company	15
Davis, R. J.	9	Mortenson Construction Co.	172	Tay Company, George H.	35
Del Favero and Rasori	142	Mott Co. of Calif.	18	Taylor, F. A. & Co.	31
Del Monte Properties Co.	20	Mueller Mfg. Co.	18	Tittle, H. S.	155
Detroit Steel Products Co.	44	Mullen Mfg. Co.	158	Tormey Co.	140
Dieckmann Hardwood Co.	12	Mushet Co., W. E.	148	Trost, Robt.	142
Direct Line Telephone Co.	159	Musto Sons Keenan Co.	13	Truscon Steel Co.	30
Dolan Wrecking & Construction Co.	158	Myers & Schwartz	36-37	Tuec Cleaner	149
Drendell Elec. & Mfg. Co.	154	Nason, R. N. & Co.	9	Uhl Bros.	38
Dudfield Lumber Co.	158	Nathan, Dohrmann Co.	51	Unit Construction Co.	142
Duncan, W. C.	144	National Magnesite Co.	17	United Electric Co.	149
Dunham, C. A. Co.	35	National Mill & Lumber Co.	33	United Materials Co.	126
Electric Outlet Co.	3	National Surety Co.	150	U. S. Metal Products Co.	26
Elevator Supplies Co.	150	National Valve Co.	130	U. S. Steel Products Co.	40
Elery Arms Co.	140	National Terra Cotta Society	125	Van Fleet-Frear Co.	143
Fess System Co.	43	Nelson, James A.	18	Vernott Marble Co.	34
Fidelity & Casualty Co. of N.Y.	150	Ne Page, McKenny Co.	155	Vukicevich & Bagee	144
Fidelity & Deposit Co. of Maryland	150	Newberry Electric Co.	155	Wadsworth, Howland & Co., Inc	132
Fink & Schindler Co., The	158	New York Belting and Packing Co.	124	Walter, D. N. & E. & Co.	145
Fire Protection Products Co.	16	Norris Co., L. A.	34	Ward, Baldwin D.	140
First National Bank	120	Oak Flooring Mfrs' Ass'n	21	Waterhouse, Wilcox Co.	32
Flagg, Edwin H., Scenic Co.	158	Ocean Shore Iron Works	138	Wayne Oil Tank & Pump Co.	33
Freeman Art Shop	31	Old Mission Portland Cement Co.	25	Weber, C. F. & Co.	153
Fuller & Goepf	24	Otis Elevator Co.	160	Wentworth, F. W.	132
Fuller, W. P. Co.	19	Pacific Coast Steel Company	151	West Coast Porcelain Co.	Back Cover
Garfield Company	157	Pacific Fire Extinguisher Co.	143	Western Blind & Screen Co.	39
Garnett, Young & Co.	20	Pacific Mfg. Co.	15	Western Electric Safety Mfg. Co.	154
General Boilers Co.	121	Pacific Materials Co.	27-41-44	Western Iron Works	6
Gilley-Schmid Co.	140	Pacific Painting and Roofing Co.	14	Western Office, Equipment Co.	34
Gladling, McBean & Co.	138	Pacific Plumbing Fixtures	2d Cover	Western Pipe and Steel Co.	147
Globe Electric Works	155	Pacific Porcelain Ware Co.	2d Cover	White Bros.	117
Globe Indemnity Co.	150	Pacific Pump & Supply Co.	38	Wilson, J. G., Corp.	139
Go-Sign & Letter Co.	145	Pacific Rolling Mills	6	Wilson, W. F., Co.	146
Golden Gate Ornamental Iron Co.	152	Palace Hardware Co.	38	Witt, G. E. Co.	44
		Palm Iron Works	6	Zelinsky, D. & Sons	145
		Palmer & Petersen	142		

Nason's Opaque Flat Finish

A Flat Washable Oil Paint, made in soft Kalsomine tints—a practical article for Walls, Ceilings, Etc. Agency for Tamm & Nolan Company's High Grade VARNISHES and FINISHES, made on the Pacific Coast to stand our climatic conditions.

R. N. NASON & CO. Paint Makers
151 Potrero Ave.—436 Market St., San Francisco—Portland—Seattle—Oregon

ARCHITECTS' SPECIFICATION INDEX—Continued

BUILDING MATERIALS, SUPPLIES, ETC.

California Brick Company, 604 Mission street, San Francisco.

Livermore Fire Brick Works, 604 Mission street, San Francisco.

Pacific Materials Co., Underwood Bldg., San Francisco.

Waterhouse-Wilcox Co., 523 Market St., San Francisco.

Johns-Manville Company, Post and Mason Sts., San Francisco.

CABINET MAKERS

Home Manufacturing Company, 543 Brannan St., San Francisco.

Fink & Schindler Co., 218 13th St., San Francisco.

Mullen Manufacturing Company, 64 Rausch St., San Francisco.

Frank Portman, 1618 Mission St., San Francisco.

CARPETS

W. & J. Sloane, 216-228 Sutter St., San Francisco.

John Breuner Co., 231 Geary St., San Francisco.

D. N. & E. Walter, Mission near Second street, San Francisco.

CASEMENT WINDOW HARDWARE

Richards-Wilcox Mfg. Co., Aurora, Ill., and Underwood Bldg., San Francisco.

CEMENT

Mt. Diablo, sold by Henry Cowell Lime & Cement Co., 2 Market St., San Francisco.

Medusa White Portland Cement, manufactured by Sandusky Cement Co., represented in San Francisco by Pacific Building Materials Co., Underwood Bldg., San Francisco.

Old Mission Portland Cement Co., Mills Building San Francisco.

CEMENT EXTERIOR WATERPROOF PAINT

Armorite, sold by W. P. Fuller & Co., all principal Coast cities.

Bay State Brick and Cement Coating, manufactured by Wadsworth, Howland Co., Boston, Mass. James Hambley & Son, Distributors, San Francisco and Los Angeles.

Hill, Hubbell & Company, No. 1 Drumm St., San Francisco.

Imperial Waterproofing, manufactured by Brooks & Doerr, Reed Baxter, agent, Merchants National Bank Bldg., San Francisco.

Paraffine Paint Co., 34 First St., San Francisco.

Medusa White Portland Cement, manufactured by Sandusky Cement Co., represented in San Francisco by Pacific Materials Co., 525 Market St., San Francisco.

CEMENT GUN

Cement Gun Construction Company of California, 701 Balboa Bldg., San Francisco.

CEMENT TESTS—CHEMICAL ENGINEERS

Robert W. Hunt & Co., 251 Kearny St., San Francisco.

CLAY PRODUCTS

California Brick Company, 604 Mission street, San Francisco.

Cannon & Co., Sacramento; and Chronicle Bldg., San Francisco.

Gladding, McBean & Co., Crocker Bldg., San Francisco.

Livermore Fire Brick Works, 604 Mission street, San Francisco.

Los Angeles Pressed Brick Co., Frost Bldg., Los Angeles.

United Materials Co., Sharon Bldg., San Francisco.

CLOCKS—ELECTRIC TIME

Standard Electric Time Co., 461 Market St., San Francisco.

COLD STORAGE PLANTS

H. W. Johns-Manville Co., Post and Mason Sts., San Francisco.

T. P. Jarvis Crude Oil Burning Co., 275 Connecticut St., San Francisco.

COMPRESSED AIR CLEANERS

United Electric Co., Canton, O., mfr. of Tucc Cleaner, sold by San Francisco Compressed Air Cleaning Co., Sutter and Stockton Sts., San Francisco.

George H. Tay Company, Mission and Second Sts., San Francisco; 10th and Harrison Sts., Oakland.

CONCRETE CONSTRUCTION

Barrett & Hilp, Sharon Bldg., San Francisco.

Clinton Construction Co., 140 Townsend street, San Francisco.

K. E. Parker Co., Inc., Clunie Bldg., San Francisco.

Palmer & Petersen, Monadnock Bldg., San Francisco.

I. M. Sommer, 401 Balboa Bldg., San Francisco.

Steelform Contracting Company, 681 Market St., San Francisco.

CONCRETE MIXERS

Foote and Jaeger mixers sold by Edward R. Bacon Co., 51 Minna St., San Francisco, also Los Angeles.

Ransome mixers sold by the Garfield Co., Hearst Bldg., San Francisco.

Smith-Booth-Usher Co., San Francisco and Los Angeles.

CONCRETE REINFORCEMENT

United States Steel Products Co., San Francisco, Los Angeles, Portland and Seattle.

Twisted Bars. Sold by Gunn, Carle & Co., Inc., 444 Market St., San Francisco.

Clinton Welded Wire Fabric, L. A. Norris Co., 140 Townsend St., San Francisco.

Pacific Coast Steel Company, Rialto Bldg., San Francisco.

Triangle Mesh Fabric. Sales agents, Pacific Materials Co., 525 Market St., San Francisco.

Truscon Steel Co., 527 Tenth St., San Francisco.

Badt-Falk Co., Call-Post Bldg., San Francisco.

CONDUITS

Garnett Young & Co., 612 Howard St., San Francisco.

CONTRACTORS, GENERAL

Barrett & Hilp, Sharon Bldg., San Francisco.

K. E. Parker Co., Inc., Clunie Bldg., San Francisco.

R. W. Littlefield, 357 12th St., Oakland.

Unit Construction Co., Pbelan Bldg., San Francisco.

J. D. Hannah, 142 Sansome St., San Francisco.

Chas. Stockholm & Son, Monadnock Bldg., San Francisco.

John M. Bartlett, 357 Twelfth St., Oakland.

E. T. Leiter & Son, Call-Post Bldg., San Francisco.

R. J. Davis

District Sales Agent

Century

**A. C. Motors
and Fans**

Complete stocks carried at: 171-173 Second St., San Francisco; 906 So. Hope St., Los Angeles

We have returned to our policy-holders annually for 33 years never less than 30% of the premium as a dividend. Dividends declared during 1919, \$2,017,893.

AMERICAN MUTUAL LIABILITY INSURANCE CO. OF BOSTON
Assets \$8,654,667 Surplus \$1,417,173

WORKMEN'S COMPENSATION, AUTOMOBILE, TEAMS AND PUBLIC LIABILITY INSURANCE

SAN FRANCISCO BRANCH OFFICE

1816 Balboa Building. Telephone Kearny 3202

N. F. Hesselatine, California Manager.

C. H. Gray, Assistant Manager.

ARCHITECTS' SPECIFICATION INDEX—Continued

- CONTRACTORS, GENERAL**—Continued
Herbert Beckwith, 323 Newton Ave., Oakland.
Collman & Speidel, 546 Monadnock Bldg., San Francisco.
Clinton Construction Company, 140 Townsend St., San Francisco.
Monson Bros., 1907 Bryant St., San Francisco.
W. C. Duncan & Co., 526 Sharon Bldg., San Francisco.
A. Knowles, Call-Post Bldg., San Francisco.
T. B. Goodwin, 180 Jessie St., San Francisco.
Lange & Bergstrom, Sharon Bldg., San Francisco.
McLeran & Peterson, Hearst Bldg., San Francisco.
Robert Trost, 26th and Howard Sts., San Francisco.
I. M. Somner, 401 Balboa Bldg., San Francisco.
Del Favero & Rasori, 180 Jessie St., San Francisco.
Jas. L. McLaughlin, 251 Kearny street, San Francisco.
- CONTRACTORS' EQUIPMENT**
Edward R. Bacon Co., 51 Minna St., San Francisco, and Los Angeles.
Garfield & Co., Hearst Bldg., San Francisco.
Smith, Booth-Usher Co., 60 Fremont St., San Francisco; 228 Central Ave., Los Angeles.
- CONTRACTORS' INSURANCE**
Bankers & Shippers Insurance Co. of New York, Insurance Exchange Bldg., San Francisco.
- CONVEYING MACHINERY**
Meese & Gottfried, San Francisco, Los Angeles, Portland and Seattle.
- CORK TILE, INSULATION, ETC.**
Van Fleet-Freear Co., Sharon Bldg., San Francisco.
- CRUSHED ROCK**
Coast Rock & Gravel Co., Call-Post Bldg., San Francisco.
- DAMP-PROOFING COMPOUND**
Armorite Damp Resisting Paint, made by W. P. Fuller & Co., San Francisco.
Hill, Hubbell & Company, No. 1 Drumm St., San Francisco.
Imperial Waterproofing, mfrd. by Brooks & Doerr, Reed Baxter, agent, Merchants National Bank Bldg., San Francisco.
"Pabco" Damp-Proofing Compound, sold by Paraffine Co., 34 First St., San Francisco.
- DOOR HANGERS**
Pitcher Hanger, sold by National Lumber Co., 326 Market St., San Francisco.
Reliance Hanger, sold by Waterhouse-Wilcox Co., San Francisco; D. F. Fryer & Co., B. V. Collins, Los Angeles, and Columbia Wire & Iron Works, Portland, Oregon.
Stanley Works, New Britain, Conn. John Rountree, agent, Monadnock Bldg., San Francisco.
Richards-Wilcox Mfg. Co., Underwood Bldg., San Francisco.
- DRINKING FOUNTAINS**
Haws Sanitary Drinking Faucet Co., 1808 Harmon St., Berkeley, and C. F. Weber & Co., San Francisco and Los Angeles.
Crane Company, San Francisco, Oakland, and Los Angeles.
Pacific Porcelain Ware Co., 67 New Montgomery St., San Francisco.
- George H. Tay Company, Mission and Second Sts., San Francisco; 10th and Harrison Sts., Oakland.
Haines, Jones & Cadbury Co., 857 Folsom St., San Francisco.
DUMB WAITERS
Spencer Elevator Company, 166 7th St., San Francisco.
M. E. Hammond, Pacific Bldg., San Francisco.
- ELECTRICAL CONTRACTORS**
Butte Electrical Equipment Company, 530 Folsom St., San Francisco.
Butte Electric & Manufacturing Co., 534 Folsom St., San Francisco.
Brown-Langlais Electrical Construction Co., 213 Minna St., San Francisco.
Central Electric Company, 185 Stevenson street, San Francisco.
NePage, McKenny Co., 589 Howard St., San Francisco.
Liberty Electric Company, 479 Sutter St., San Francisco.
Newbery Electrical Co., 413 Lick Bldg., San Francisco.
Pacific Fire Extinguisher Co., 424 Howard St., San Francisco.
Globe Electric Works, 1959 Mission St., San Francisco.
M. E. Ryan, Redwood City, Calif.
Rex Electric & Engineering Co., 253 Minna St., San Francisco.
H. S. Tittle, 766 Folsom St., San Francisco.
Severin Electrical Company, 185 Stevenson St., San Francisco.
Spott Electrical Co., Sixteenth and Clay Sts., Oakland.
- ELECTRIC PLATE WARMER**
The Prometheus Electric Plate Warmer for residences, clubs, hotels, etc. Sold by M. E. Hammond, Pacific Bldg., San Francisco.
- ELECTRICAL SUPPLIES AND EQUIPMENT**
Garnett Young & Co., 612 Howard St., San Francisco.
Butte Electrical Equipment Co., 530 Folsom St., San Francisco.
Electric Outlet Co., Inc., 119 West 40th St., New York.
Safety Electric Company, 56-65 Columbia Square, San Francisco.
Drendell Electrical & Mfg. Co., 1345 Howard St., San Francisco.
R. J. Davis, District Sales Agent, Century A. C. Motors and Fans, 171 Second St., San Francisco.
Western Electric Safety Mfg. Co., Inc., 247 Minna street, San Francisco.
- ELEVATORS**
Otis Elevator Company, Stockton and North Point, San Francisco.
Spencer Elevator Company, 166 7th St., San Francisco.
- ELEVATOR EQUIPMENT**
Elevator Supplies Company, Inc., 186 Fifth St., San Francisco.
- ENGINEERS—CONSULTING; ELECTRICAL, MECHANICAL**
Chas. T. Phillips, Pacific Bldg., San Francisco.
Hunter & Hudson, Rialto Bldg., San Francisco.
Baldwin D. Ward, 76 13th St., Oakland.

**KEWANEE
GARBAGE BURNERS
AND
BOILERS**

**YEOMANS
BILGE PUMPS
EJECTORS
HOUSE PUMPS**

**OVERHEAD
CARRYING
SYSTEMS**

CALIFORNIA HYDRAULIC ENGINEERING & SUPPLY CO., 80 Fremont St., S. F.



TEMPERATURE REGULATION

JOHNSON SERVICE COMPANY

(OF MILWAUKEE — ESTABLISHED 1885)

Manufacturers and Installers of **JOHNSON Heat Humidity CONTROL**

For schools, residences, hospitals, banks, public buildings, also canneries and all kinds of industrial plants—Hot water tank regulators, air and water reducing valves.

Rialto Bldg., SAN FRANCISCO 605 Van Nuys Bldg., LOS ANGELES



ARCHITECTS' SPECIFICATION INDEX—Continued

- ELEVATOR DOOR HARDWARE**
Richards-Wilcox Mfg. Co., Underwood Bldg., San Francisco.
- FANS AND BLOWERS**
Ideal Heating & Engineering Co., 192 Erie St., San Francisco.
- FENCES—WIRE**
Standard Fence Construction Co., 245 Market St., San Francisco, and 310 12th St., Oakland.
- FILLING STATION EQUIPMENT**
S. F. Bowser & Co., Inc., 612 Howard St., San Francisco.
Wayne Oil Tank & Pump Co., 631 Howard St., San Francisco, 830 S. Los Angeles St., Los Angeles.
- FIRE BRICK**
Livermore Fire Brick Works, 604 Mission street, San Francisco.
- FIRE ESCAPES**
Palm Iron & Bridge Works, Sacramento.
Western Iron Works, 141 Beale St., San Francisco.
Golden Gate Iron Works, 1541 Howard St., San Francisco.
- FIRE EXTINGUISHERS**
American La France Fire Engine Co., Inc., 151 New Montgomery St., San Francisco; Los Angeles and Portland.
- FIRE INSURANCE**
Bankers & Shippers Insurance Co., Insurance Exchange Bldg., San Francisco.
- FIRE PROOFING**
American Insulux Company, Berkeley Bank Bldg., Berkeley.
- FIRE SPRINKLERS—AUTOMATIC**
Grinnell Company, 453 Mission St., San Francisco.
Pacific Fire Extinguisher Co., 424 Howard St., San Francisco.
- FIRE RETARDING PAINT**
The Paraffine Companies, Inc., 34 First St., San Francisco.
- FIXTURES—BANK, OFFICE, STORE, ETC.**
Home Manufacturing Company, 543 Brannan St., San Francisco.
The Fink & Schindler Co., 218 13th St., San Francisco.
Mullen Manufacturing Co., 64 Rausch St., San Francisco.
C. F. Weber & Co., 985 Market St., San Francisco, and 210 N. Main St., Los Angeles, Cal.
- FLOOR TILE**
Mangrum & Otter, 827 Mission St., San Francisco.
- FLOOR VARNISH**
Bass-Hueter and San Francisco Pioneer Varnish Works, 316 Mission St., San Francisco.
Fifteen for Floors, made by W. P. Fuller & Co., San Francisco.
Standard Varnish Works, Chicago, New York and San Francisco.
R. N. Nason & Co., San Francisco and Los Angeles.
- FLOORS—HARDWOOD**
Oak Flooring Manufacturers' Association of the United States, Ashland Block, Chicago, Ill.
- Parrott & Co., 320 California St., San Francisco.
White Bros., Fifth and Brannan Sts., San Francisco.
Strable Hardwood Company, 511 First street, Oakland.
- FLOORS—MASTIC**
Hill, Hubbell & Company, No. 1 Drumm St., San Francisco.
- FLOORS—DUST PROOF CEMENT**
L. Sonneborn Co., United Materials Co., San Francisco agents.
- FLUMES**
California Corrugated Culvert Co., West Berkeley, Cal.
- FLUSH VALVES**
National Valve Company, 23-25 Minna St., San Francisco.
- FRUIT DRYING MACHINERY**
Ideal Heating & Engineering Co., 192 Erie St., San Francisco.
Jas. A. Nelson, 517 Sixth St., San Francisco.
- FUEL OIL SYSTEMS**
S. T. Johnson Co., 1337 Mission St., San Francisco.
S. F. Bowser & Co., Inc., 612 Howard St., San Francisco.
Wayne Oil Tank & Pump Co., 631 Howard St., San Francisco.
- FURNACES—WARM AIR**
Mangrum & Otter, 827 Mission St., San Francisco.
Montague Range and Furnace Co., 826 Mission St., San Francisco.
- FURNITURE—BUILT-IN**
Hoosier Kitchen Cabinet Store, Pacific Bldg., San Francisco.
- FURNITURE—SCHOOL, CHURCH, OFFICE, HOUSE, ETC.**
Home Manufacturing Company, 543 Brannan St., San Francisco.
C. F. Weber & Co., 985 Market St., San Francisco.
Rucker-Fuller Desk Co., 677 Mission St., San Francisco.
F. W. Wentworth & Co., 539 Market St., San Francisco.
W. & J. Sloane, 216-228 Sutter St., San Francisco.
- GALVANIZED IRON WORK**
James A. Nelson, 517 Sixth St., San Francisco.
- GARAGE HARDWARE**
The Stanley Works, New Britain, Conn., represented in San Francisco, Los Angeles, Seattle by John T. Rowntree, Inc.
Richards-Wilcox Mfg. Co., Aurora, Ill., and Underwood Bldg., San Francisco.
- GARBAGE CHUTES AND INCINERATORS**
Kerner Incinerator Co., 77 O'Farrell St., San Francisco.
California Hydraulic Engineering & Supply Co., 70-72 Fremont St., San Francisco.
- GAS STEAM RADIATORS—FUMELESS, ETC.**
Clow Gas Steam Radiators, F. A. Hamilton, Agent, 101 Rialto Bldg., San Francisco.

ROBERTSON PROCESS METAL FOR ROOFING AND SIDING

HH ROBERTSON CO
BUILDING PRODUCTS

FORMERLY ASBESTOS PROTECTED METAL COMPANY

Hobart Building, San Francisco

Phone Garfield 522

When writing to Advertisers please mention this magazine.

DIECKMANN HARDWOOD COMPANY

Office, Mill, Yards, and Dry Kilns
BEACH AND TAYLOR STS.
 SAN FRANCISCO, CAL.
 PHONE FRANKLIN 2302

**Foreign & Domestic
 CABINET WOODS**

ARCHITECTS' SPECIFICATION INDEX—Continued

- GAS STEAM RADIATORS, ETC.**—Continued.
 Ra-Do Fumeless Gas Radiators, manufactured and sold by Baird-Bailhache Co., 478 Sutter St., San Francisco.
- GLASS**
 American Window Glass Co., represented by L. H. Butcher Co., 341 Montgomery St., San Francisco.
 Cobbleck-Kibbe Glass Co., 175 Jessie St., San Francisco.
 Fuller & Goepf, 32 Page St., San Francisco.
 W. P. Fuller & Company, all principal Coast cities.
- GRADING, WRECKING, ETC.**
 Dolan Wrecking & Construction Co., 1607 Market St., San Francisco.
- GRANITE**
 California Granite Co., Gen. Contractors' Ass'n, San Francisco.
 Raymond Granite Co., Potrero Ave. and Division St., San Francisco.
- GRAVEL AND SAND**
 Coast Rock & Gravel Co., Call-Post Bldg., San Francisco.
 Del Monte White Sand, sold by Del Monte Properties Co., Crocker Bldg., San Francisco.
- GYMNASIUM EQUIPMENT**
 Ellery Arms Co., 583 Market St., San Francisco.
 A. G. Spalding & Bros., 158 Geary St., San Francisco.
- HARDWALL PLASTER**
 Henry Cowell Lime & Cement Co., San Francisco.
- HARDWARE**
 Joost Bros., agents for Russell & Erwin hardware, 1053 Market St., San Francisco.
 The Stanley Works, New Britain, Conn.; Coast sales offices, San Francisco, Los Angeles, and Seattle, Wash.
 Corbin hardware, sold by Palace Hardware Co., 581 Market St., San Francisco.
 Richards-Wilcox Mfg. Co., Aurora, Ill., Ewing-Lewis Co., 626 Underwood Bldg., San Francisco.
- HARDWOOD LUMBER—FLOORING, ETC.**
 Dieckmann Hardwood Company, Beach and Taylor Sts., San Francisco. (See advertisement above.)
 Inlaid Floor Co., 600 Alabama St., San Francisco.
 H. N. McNab, 2307 17th Ave., Oakland.
 Parrott & Co., 320 California St., San Francisco.
 White Bros., cor. Fifth and Brannan Sts., San Francisco.
 Strable Hardwood Company, First street, near Broadway, Oakland.
- HEATERS—AUTOMATIC—GAS**
 Pittsburg Water Heater Co., 478 Sutter St., San Francisco.
 George H. Tay Company, Mission and Second Sts., San Francisco; 10th and Harrison Sts., Oakland.
 Ra-Do Fumeless Gas Heater, sold by Baird-Bailhache Company, 478 Sutter St., San Francisco.
- HEATING AND VENTILATING MATERIAL, ETC.**
 Alex Coleman, 706 Ellis St., San Francisco.
- C. A. Dunham Co., Sheldon Building, San Francisco.
 Gilley-Schmid Company, 198 Otis St., San Francisco.
 Hateley & Hateley, Mitau Bldg., Sacramento.
 Knittle-Cashel Co., Inc., 1820 Ellis St., San Francisco.
 General Boilers Co., 332 Monadnock Bldg., San Francisco.
 Mangrum & Otter, 827-831 Mission St., San Francisco.
 Moline Heat, Hobart Bldg., San Francisco.
 James & Drucker, 450 Hayes St., San Francisco.
 James A. Nelson, 517 Sixth St., San Francisco.
 Ideal Heating & Engineering Co., 192 Eric St., San Francisco.
 Illinois Engineering Co., 563 Pacific Bldg., San Francisco.
 William F. Wilson Co., 328 Mason St., San Francisco.
 Pacific Fire Extinguisher Co., 424 Howard St., San Francisco.
 Scott Company, 243 Minna St., San Francisco.
 Mechanical Engineering & Supply Co., 908 7th St., Sacramento.
 George H. Tay Company, Mission and Second Sts., San Francisco; 10th and Harrison Sts., Oakland.
 O. M. Simmons Co., 115 Mission St., San Francisco.
- HOLLOW TILE BLOCKS**
 Cannon & Co., plant at Sacramento; office in Chronicle Bldg., San Francisco.
 Gladding, McBean & Co., San Francisco, Los Angeles, Oakland and Sacramento.
 Los Angeles Pressed Brick Co., Frost Bldg., Los Angeles.
 California Brick Company, 604 Mission street, San Francisco.
 Livermore Fire Brick Works, 604 Mission street, San Francisco.
- HOSPITAL FIXTURES**
 Mott Company of California, 553 Mission St., San Francisco.
 George H. Tay Company, Mission and Second Sts., San Francisco; 10th and Harrison Sts., Oakland.
- HOSPITAL SIGNAL SYSTEM**
 Chicago Signal Co., represented by Garnett, Young & Co., 612 Howard St., San Francisco.
- HOTELS**
 St. Francis Hotel, Powell, Geary and Post Sts., San Francisco.
- INGOT IRON**
 "Armco" brand, manufactured by American Rolling Mill Company, Middletown, Ohio, and 10th and Bryant streets, San Francisco.
- INSPECTIONS AND TESTS**
 Robert W. Hunt & Co., 251 Kearny St., San Francisco.
- INSULATION**
 American Insulux Company, Berkeley Bank building, Berkeley.
- INCINERATORS**
 Kerner Incinerator Co., 77 O'Farrell St., San Francisco.

"The
 Perfect
 Automatic
 Valve"

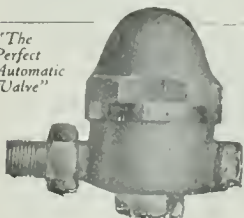

Haines Heating Systems

ASSURE

Heating Satisfaction

O. M. SIMMONS CO.

115 Mission St., San Francisco
 Phone: Douglas 5497

CLARENCE E. MUSTO. Pres.

JOSEPH B. KEENAN. Vice-Pres.

GUIDO J. MUSTO. Sec'y & Treas.

JOSEPH MUSTO SONS=KEENAN CO.Phone Franklin
—6365—**MARBLE**OFFICE AND MILLS:
535-565 North Point St.,
SAN FRANCISCO, CAL.**ARCHITECTS' SPECIFICATION INDEX—Continued****INTERIOR DECORATORS**

Beach-Robinson Co., 239 Geary St., San Francisco.

INTERIOR DECORATORS.—Continued.John Breuner Co., 281 Geary St., San Francisco.
Sonnenschein Bros., 470 Sutter St., San Francisco.The Tormey Co., 1042 Larkin St., San Francisco.
F. A. Taylor & Co., 318 Stockton street, San Francisco.

Freeman Art Shop, 386 Sutter St., San Francisco.

W. & J. Sloane, 216 Sutter St., San Francisco.

KITCHEN CABINETS

Hoosier Kitchen Cabinet Store (O. K. Brown, Mgr.), Pacific Bldg., San Francisco.

KITCHEN EQUIPMENT

James A. Nelson, 517-19 Sixth street, San Francisco.

LAMP POSTS, ELECTROLIERS, ETC.

J. L. Mott Iron Works, 553 Mission St., San Francisco.

LANDSCAPE GARDENERS

MacRorie-McLaren Co., 141 Powell St., San Francisco.

LATHING AND PLASTERING

MacGruer & Simpson, Call-Post Bldg., San Francisco.

A. Knowles, Call-Post Bldg., San Francisco.

Jas. F. Smith, 273 Minna St., San Francisco.

LATHING MATERIAL

Pacific Material Co., 525 Market St., San Francisco.

Key-Hold Plaster Lath Co., 148 Hooper St., San Francisco.

Truscon Steel Co., Tenth St., near Bryant, San Francisco.

LIGHT, HEAT AND POWER

Great Western Power Company, Stockton St., near Sutter, San Francisco.

LIGHTING FIXTURES

Roberts Mfg Co., 663 Mission St., San Francisco.

Perfeelite Manufacturing Co., Seattle, Wash.;
San Francisco Representatives, Myers & Schwartz,
75 New Montgomery street, San Francisco;
1119 S. Los Angeles street, Los Angeles.**LIME**

Henry Cowell Lime & Cement Co., 2 Market St., San Francisco.

LINOLEUM

D. N. & E. Walter & Co., 562 Mission St., San Francisco.

The Paraffine Companies, factory in Oakland;
office, 34 First St., near Market, San Francisco.

W. & J. Sloane, 216-228 Sutter St., San Francisco.

LUBRICATING OIL STORAGE TANKS AND PUMPS

S. F. Bowser & Co., Inc., 612 Howard St., San Francisco.

LUMBER

California Redwood Association, 216 Pine St., San Francisco.

Dudfield Lumber Co., Palo Alto, Cal.

Hart-Wood Lumber Co., Fifth and Berry Sts., San Francisco.

Pacific Manufacturing Company, San Francisco, Oakland and Santa Clara.

Pope & Talbot, foot of Third St., San Francisco.

Portland Lumber Co., 16 California St., San Francisco.

Sunset Lumber Company, First and Oak Sts., Oakland.

MAIL CHUTES

American Mailing Device Corp., represented on Pacific Coast by Waterhouse-Wilcox Co., 523 Market St., San Francisco.

MANTELS

Mangrum & Otter, 827-831 Mission St., San Francisco.

California Brick Company, 604 Mission street, San Francisco.

MANUAL TRAINING EQUIPMENT

Richards-Wilcox Mfg. Co., Ewing-Lewis Co., 626 Underwood Bldg., San Francisco.

Smith-Booth-Usher Co., San Francisco and Los Angeles.

MARBLE

American Marble and Mosaic Co., 25 Columbus Square, San Francisco.

Joseph Musto Sons, Keenan Co., 535 N. Point St., San Francisco.

Vermont Marble Co., Coast branches, San Francisco, Portland and Tacoma.

METAL DOORS AND WINDOWS

Fire Protection Products Co., 3117 20th St., San Francisco.

Waterhouse-Wilcox Co., Inc., 523 Market St., San Francisco.

U. S. Metal Products Co., 330 Tenth St., San Francisco.

MILL WORK

Dudfield Lumber Co., Palo Alto, Cal.

Pacific Manufacturing Company, San Francisco, Oakland and Santa Clara.

National Mill and Lumber Co., San Francisco and Oakland.

The Fink & Schindler Co., 218 13th St., San Francisco.

Frank Portman, 1619-20 Mission St., San Francisco.

MOTORS AND FANS

R. J. Davis, Dist. Sales Agent Century Motors and Fans, 171 Second St., San Francisco.

OIL BURNERS

American Standard Oil Burner Company, Berkeley.

Fess System Co., 220 Natoma St., San Francisco.

S. T. Johnson Co., 1337 Mission St., San Francisco.

T. P. Jarvis Manufacturing Co., 275 Connecticut St., San Francisco.

W. S. Ray Mfg. Co., 29 Spear St., San Francisco.

G. E. Witt Co., 862 Howard St., San Francisco.

OIL STORAGE AND DISTRIBUTING STATIONS

S. F. Bowser & Co., Inc., 612 Howard St., San Francisco.

S. T. Johnson Co., 1337 Mission St., San Francisco.

KNITTLE-CASHEL CO., Inc.

HEATING CONTRACTORS

STEAM HEATING
HOT WATER HEATINGVENTILATING
POWER PLANTSGENERAL PIPE WORK
REPAIRING

1820-22 Ellis Street, San Francisco

Phone West 964



CAL-PA-CO On Your Best Work Specify

CAL-PA-CO DAMPSTOP (Outside)
WASHABLE WALL (Inside)

FOR CONCRETE BUILDINGS.

Everything Reliable in PAINT and VARNISH

CALIFORNIA PAINT COMPANY, OAKLAND, CALIF., U. S. A.
MANUFACTURERS SINCE 1865 SAN FRANCISCO OFFICE, MONADNOCK BUILDING

ARCHITECTS' SPECIFICATION INDEX—Continued

- Wayne Oil Tank & Pump Co., 631 Howard St., San Francisco; 830 S. Los Angeles St., Los Angeles.
- OFFICE EQUIPMENT**
C. F. Weber Co., 985 Market St., San Francisco.
Rucker-Fuller Co., 677 Mission St., San Francisco.
- F. W. Wentworth & Co., 539 Market St., San Francisco.
- ORNAMENTAL IRON AND BRONZE**
California Artistic Metal and Wire Co., 349 Seventh St., San Francisco.
Palm Iron & Bridge Works, Sacramento.
C. J. Hillard Company, Inc., 19th and Minnesota Sts., San Francisco.
- ORNAMENTAL IRON AND BRONZE.—Cont.**
Schrader Iron Works, Inc., 1247 Harrison St., San Francisco.
- OVERHEAD CARRYING SYSTEMS**
California Hydraulic Engineering & Supply Co., 70-72 Fremont St., San Francisco.
Richards-Wilcox Mfg. Co., Aurora, Ill., and Underwood Bldg., San Francisco.
- PAINT FOR STEEL STRUCTURES, BRIDGES, ETC.**
The Paraffine Companies, Inc., 34 First St., San Francisco.
Premier Graphite Paint and Pioneer Brand Red Lead, made by W. P. Fuller & Co., San Francisco.
- Hill, Hubbell & Company, No. 1 Drumm St., San Francisco.
Wadsworth, Howland Co., makers of Bay State Brick and Cement Coating, Boston, Mass.
Hambly & Son, Distributors in San Francisco and Los Angeles.
- PAINTING, TINTING, ETC.**
I. R. Kissel, 1747 Sacramento St., San Francisco.
D. Zelinsky & Sons, San Francisco and Los Angeles.
The Tormey Co., 681 Geary St., San Francisco.
Pick Bros., 475 Haight St., San Francisco.
Pacific Painting and Roofing Co., Pacific building, San Francisco; and 388 12th street Oakland.
- PAINTS, OILS, ETC.**
California Paint Company (see advertisement above).
Magner Bros., 414-424 Ninth St., San Francisco.
Bass-Hueter Paint Co., Mission, near Fourth St., San Francisco.
R. N. Nason & Company, San Francisco, Los Angeles, Portland and Seattle.
Ronfle Company, Pacific building, San Francisco; and 388 12th street, Oakland.
W. P. Fuller & Co., all principal Coast cities.
"Satinette," Standard Varnish Works, 55 Stevenson St., San Francisco.
Palace Hardware Co., 581 Market St., San Francisco.
- PANELS AND VENEER**
White Bros., Fifth and Brannan Sts., San Francisco.
- PARTITIONS—FOLDING AND ROLLING**
J. G. Wilson Corporation, 600 Metropolitan Bldg., Los Angeles; Waterhouse-Wilcox Co., Underwood Bldg., San Francisco.
- PENCILS**
Eberhard Faber, Monadnock Bldg., San Francisco.
- PIPE—STEEL AND WROUGHT IRON**
Western Pipe & Steel Co., 444 Market St., San Francisco; 1758 N. Broadway, Los Angeles.
George H. Tay Company, Mission and Second Sts., San Francisco; 10th and Harrison Sts., Oakland.
- PLAYGROUND EQUIPMENT**
A. G. Spalding & Bros., 158 Geary St., San Francisco.
- PLUMBING CONTRACTORS**
Alex Coleman, 706 Ellis St., San Francisco.
Gilley-Schmid Company 198 Otis St., San Francisco.
Hateley & Hateley, Mitau Bldg., Sacramento.
Scott Co., Inc., 243 Minna St., San Francisco.
Wm. F. Wilson Co., 328 Mason St., San Francisco.
- PLUMBING FIXTURES, MATERIALS, ETC.**
California Steam & Plumbing Supply Co., 671 Fifth St., San Francisco.
Jas. B. Clow, plumbing, Rialto Bldg., San Francisco.
Crane Co., San Francisco, Oakland, Los Angeles.
Gilley-Schmid Company, 198 Otis St., San Francisco.
Haines, Jones & Cadbury Co., 857 Folsom St., San Francisco.
H. Mueller Manufacturing Company, 635 Mission St., San Francisco.
Holbrook, Merrill & Stetson, 64 Sutter St., San Francisco.
J. L. Mott Iron Works, D. H. Gulick, selling agent, 553 Mission St., San Francisco.
National Valve Company, 23-25 Minna St., San Francisco.
Pacific Sanitary Manufacturing Co., 67 New Montgomery St., San Francisco.
George H. Tay Company, Mission and Second Sts., San Francisco; 10th and Harrison Sts., Oakland.
West Coast Porcelain Manufacturers, Rialto building, San Francisco.
Wm. F. Wilson Co., 328 Mason St., San Francisco.
- POWER PLANTS**
Knittle-Cashel Co., Inc., 1820 Ellis St., San Francisco.
- POWER TRANSMITTING MACHINERY**
Meese & Gottfried, San Francisco, Los Angeles, Portland, Ore., and Seattle, Wash.
- PUMPS**
Chicago Pump Co., represented by Garnett, Young & Co., 612 Howard St., San Francisco.
California Hydraulic Engineering & Supply Co., 70 Fremont St., San Francisco.
Simonds Machinery Co., 117 New Montgomery St., San Francisco.
Ocean Shore Iron Works, 558 Eighth St., San Francisco.
Pacific Pump & Supply Company, 851-853 Folsom St., San Francisco.
George H. Tay Company, Mission and Second Sts., San Francisco; 10th and Harrison Sts., Oakland.
- PUMPS—HAND OR POWER, FOR OIL AND GASOLINE**
S. F. Bowser & Co., Inc., 612 Howard St., San Francisco.

DUNN SPRAY METHOD OF PAINTING

Saves Time, Labor and Material—Will outwear paint applied by other methods.
→ **ROBELE** Special Paints for Specific Purposes Used Unless Otherwise Specified.

PACIFIC PAINTING AND ROOFING COMPANY

G. D. NEWTON, Manager

PACIFIC BLDG., SAN FRANCISCO. 388-12th St., OAKLAND



Yards { TRACY, CAL.
BRENTWOOD, CAL.

Phone KEARNY 2074

PORTLAND LUMBER COMPANY

A. J. RUSSELL, Agent

LUMBER

SIMPLEX SILOS
SAGINAW SPECIAL SHINGLES
*Ship Timbers, Oil Rigs and
Special Bills Cut to Order.*

16 California Street

San Francisco, Cal.

from tree to Consumer

Pine and Redwood Lumber

SASH DOORS AND MILL WORK

SUNSET LUMBER COMPANY

MANUFACTURERS — WHOLESALE AND RETAIL

Main Office and Yards:

FIRST AND OAK STREETS, OAKLAND

Phone Oakland 1820

POPE & TALBOT

Manufacturers, Exporters and Dealers in

Lumber, Timber, Piles, Spars, etc.

Office, Yards and Planing Mills

859-869 THIRD ST., SAN FRANCISCO, CAL.

Mills, Port Gamble, Port Ludlow and Utsalady, Washington

PACIFIC MANUFACTURING COMPANY

MILLWORK, SASH AND DOORS

Hardwood Interior Trim a Specialty

Main Office:

SANTA CLARA, CALIF.

SAN FRANCISCO, 177 Stevenson Street
OAKLAND, 1001 Franklin Street

LOS ANGELES, 908 Washington Building
SAN JOSE, 16 North First Street

ARCHITECTS' SPECIFICATION INDEX—Continued

- PUMPS (Continued)**
 S. T. Johnson Co., 1337 Mission St., San Francisco.
 Wayne Oil Tank & Pump Co., 631 Howard St., San Francisco; 830 S. Los Angeles St., Los Angeles.
 George H. Tay Company, Mission and Second Sts., San Francisco; 10th and Harrison Sts., Oakland.
- RADIATOR TRAPS**
 C. A. Dunham Co., Sheldon Bldg., San Francisco.
- REFRIGERATORS**
 McCray Refrigerator Company, San Francisco office, 765 Mission street.
- REVERSIBLE WINDOWS**
 Hauser Window Company, 157 Minna St., San Francisco.
- ROOFING AND ROOFING MATERIALS**
 Bender Roofing Company, Monadnock Bldg., San Francisco.
 "Malthoid" and "Ruberoid," manufactured by Paraffine Companies, Inc., San Francisco.
 United Materials Co., Crossley Bldg., San Francisco.
 H. H. Robertson Co., Hobart Bldg., San Francisco.
- ROOFING AND ROOF MATERIALS**
 California Brick Company, 604 Mission street, San Francisco.
- RUBBER TILING**
 New York Belting and Packing Company, 518 Mission St., San Francisco.
- SAFETY TREADS**
 Pacific Materials Co., 525 Market St., San Francisco.
- SAND**
 Del Monte White Sand, Del Monte Properties Co., 401 Crocker Bldg., San Francisco.
- SASH CORD**
 Samson Spot Sash Cord, John T. Rowntree, Pacific Coast Agent, San Francisco and Los Angeles.
- SCENIC PAINTING—DROP CURTAINS, ETC.**
 The Edwin H. Flagg Scenic Co., 1638 Long Beach Ave., Los Angeles.
- SCHOOL FURNITURE AND SUPPLIES**
 C. F. Weber & Co., 985 Market St., San Francisco; 512 S. Broadway, Los Angeles.
 Rucker-Fuller Desk Company, 677 Mission St., San Francisco.
- SHEATHING AND SOUND DEADENING**
 Samuel Cabot Mfg. Co., Boston, Mass., agencies in San Francisco, Oakland, Los Angeles, Portland, Tacoma and Spokane.
 The Paraffine Companies, Inc., 34 First St., San Francisco.
- SHEET METAL WORK**
 Jas. A. Nelson, 517 Sixth St., San Francisco.
- SHINGLE STAINS**
 Bass-Hueter Paint Company, all principal Coast cities.
 Cabot's Creosote Stains, sold by Pacific Building Materials Co., 525 Market St., San Francisco.
 Fuller's Pioneer Shingle Stains, made by W. P. Fuller & Co., San Francisco.
 Argonaut Shingle Stains, The Glidden Co., 123 Hooper St., San Francisco.
- SINKS—COMPOSITION**
 Petrium Sanitary Sink Co., Fifth and Page Sts., Berkeley.
- SKYLIGHTS**
 H. H. Robertson Co., Hobart Bldg., San Francisco.
 Jas. A. Nelson, 517 Sixth St., San Francisco.
- STATIONERY AND SUPPLIES**
 Schwabacher-Frey Stationery Co., 609 Market St., San Francisco.
 H. S. Crocker Co., 565 Market street, San Francisco.
- STEEL HEATING BOILERS**
 California Hydraulic Engineering & Supply Co., 70-72 Fremont St., San Francisco.
 General Boilers Co., 332 Monadnock Bldg., San Francisco.
- STEEL TANKS, PIPE, ETC.**
 Ocean Shore Iron Works, 558 Eighth St., San Francisco.
 S. T. Johnson Co., 1337 Mission St., San Francisco.
 Western Pipe & Steel Co., 444 Market St., San Francisco.
- STEEL AND IRON—STRUCTURAL**
 Central Iron Works, 621 Florida St., San Francisco.
 Golden Gate Iron Works, 1541 Howard St., San Francisco.
 Mortenson Construction Co., 19th and Indiana Sts., San Francisco.
 Pacific Rolling Mills, 17th and Mississippi Sts., San Francisco.
 Palm Iron & Bridge Works, Sacramento.
 U. S. Steel Products Co., Rialto Bldg., San Francisco.
 Schrader Iron Works, Inc., 1247 Harrison St., San Francisco.
 Western Iron Works, 141 Beale St., San Francisco.
- STEEL PRESERVATIVES**
 Hill, Hubbell & Company, No. 1 Drumm St., San Francisco.
- STEEL ROLLING DOORS**
 Kinnear Steel Rolling Door Co., Pacific Building Materials Co., agents, Underwood Bldg., San Francisco.
 J. G. Wilson Corporation, 600 Metropolitan Bldg., Los Angeles.
- STEEL SASH**
 Bayley-Springfield solid steel sash, sold by Pacific Materials Co., 525 Market St., San Francisco.
 "Fenestra," solid steel sash, manufactured by Detroit Steel Products Company, Detroit, Mich. Direct factory sales office, Foxcroft Bldg., San Francisco.
 U. S. Metal Products Company, 330 Tenth St., San Francisco.
 Truscon Steel Company, 527 Tenth street, San Francisco.
- STEEL WHEELBARROWS**
 Champion and California steel brands, made by Western Iron Works, 141 Beale St., San Francisco.
- STORE FRONTS**
 The Kawneer Manufacturing Company, West Berkeley, California.
 Zouri Safety Sash Bars—Cobbledick-Kibbe Glass Company, 175 Jessie St., San Francisco.
- STUDDING—FIREPROOF STEEL**
 Steel Studding Company, 1216 Folsom St., San Francisco.
- SUMP AND BILGE PUMPS**
 California Hydraulic Engineering & Supply Co., 70-72 Fremont St., San Francisco.
- SWITCHES**
 Wemco Safety Switch, manufactured and sold by W. E. Mushet Co., 502 Mission St., San Francisco.
 Western Electric Safety Switch Co., Inc., 247 Minna street, San Francisco.
- TANKS FOR OIL, GASOLINE, KEROSENE, ETC.**
 S. F. Bowser & Co., Inc., 612 Howard St., San Francisco.
 Wayne Oil Tank & Pump Co., 631 Howard St., San Francisco; 830 S. Los Angeles St., Los Angeles.
- TANKS—REDWOOD**
 Redwood Manufactures Co., Hobart Bldg., San Francisco.
- TELEPHONE AND ELECTRIC EQUIPMENT**
 Direct Linc Telephone Co., 320 Market St., San Francisco.

STEEL SASH — FIRE DOORS — SHEET METAL

Kalamein, Copper and Bronze Doors and Trim Sheet Metal Work of Every Description

FIRE PROTECTION PRODUCTS CO.

3117-3119 TWENTIETH STREET, Near Harrison, SAN FRANCISCO. Phone Mission 2607

ARCHITECTS' SPECIFICATION INDEX—Continued

THEATER AND OPERA CHAIRS

C. F. Weber & Co., 365 Market St., San Francisco.
Rucker-Fuller Desk Co., 677 Mission St., San Francisco.

THERMOSTATS FOR HEAT REGULATION

Johnson Service, Rialto Bldg., San Francisco.

TILES, MOSAICS, MANTELS, ETC.

Mangrum & Otter, 827-831 Mission St., San Francisco.

TILE FOR ROOFS

Cannon & Co., Sacramento; and Chronicle Bldg., San Francisco.

California Brick Company, 604 Mission street, San Francisco.

Gladding, McBean & Co., Crocker Bldg., San Francisco.

United Materials Co., Crossley Bldg., San Francisco.

TRANSMISSION MACHINERY

Meese & Gottfried Co., San Francisco, Los Angeles and Portland.

VACUUM CLEANERS

United Electric Company, Canton, O., manufacturers of Tucc Cleaners, sold in California by San Francisco Compressed Air Cleaning Co., Stockton and Sutter Sts., San Francisco.

VALVES—PIPES AND FITTINGS

California Steam & Plumbing Supply Co., 671 Fifth St., San Francisco.

Crane Radiator Valves, manufactured by Crane Co., Second and Brannan Sts., San Francisco.

National Valve Company, 23-25 Minna St., San Francisco.

Grinnell Co., 453 Mission St., San Francisco.

O. M. Simmons Co., 115 Mission St., San Francisco.

H. Mueller Mfg. Co., 635 Mission St., San Francisco.

W. E. Mushet Co., 502 Mission St., San Francisco.

George H. Tay Company, Mission and Second Sts., San Francisco; 10th and Harrison Sts., Oakland.

VALVE PACKING

N. H. Cook Belting Co., 317 Howard St., San Francisco.

VARNISHES

California Paint Company, 1797 Twelfth St., Oakland.

W. P. Fuller Co., all principal Coast cities.

R. N. Nason & Co., San Francisco, Los Angeles, Portland and Seattle.

S. F. Pioneer Varnish Works, 816 Mission St., San Francisco.

Standard Varnish Works, 55 Stevenson St., San Francisco.

VENETIAN BLINDS, AWNINGS, ETC.

C. F. Weber & Co., 985 Market St., San Francisco.

Western Blind & Screen Co., 2702 Long Beach Ave., Los Angeles.

VENTILATORS

H. H. Robertson Co., Hobart Bldg., San Francisco.

VITREOUS CHINAWARE

Pacific Porcelain Ware Company, 67 New Montgomery St., San Francisco.

West Coast Porcelain Manufacturers, Rialto Building, San Francisco.

WALL BEDS, SEATS, ETC.

Marshall & Stearns Co., 1154 Phelan Bldg., San Francisco.

WALL BOARD

"Amiud" Wall Board, manufactured by The Paraffine Companies, Inc., 34 First St., San Francisco

"Liberty" Wall Board, manufactured by Key-Hold Plaster Lath Co., 148 Hooper St., San Francisco.

WALL PAINT

Nason's Opaque Flat Finish, manufactured by R. N. Nason & Co., San Francisco, Portland and Los Angeles.

San-A-Cote and Vel-va-Cote, manufactured by the Brininstool Co., Los Angeles.

WALL PAPER AND DRAPERIES

Beach-Robinson Co., 239 Geary St., San Francisco.

The Tormey Co., 681 Geary St., San Francisco.

W. & J. Sloane, 216-228 Sutter St., San Francisco.

Uhl Bros., San Francisco.

WATERPROOFING FOR CONCRETE, BRICK, ETC.

Armorite Damp Resisting Paint, made by W. P. Fuller & Co., San Francisco.

Bay State Brick & Cement Coating, manufactured by Wadsworth, Howland Co., Boston; Hambley & Son., Distributors for Northern and Southern California.

Imperial Waterproofing, mfrd. by Brooks & Doerr, Reed Baxter, agent, Merchants National Bank Bldg., San Francisco.

Pacific Materials Co., 525 Market St., San Francisco.

Samuel Cabot Mfg. Co., Boston, Mass., agencies in San Francisco, Oakland, Los Angeles, Portland, Tacoma and Spokane.

WATER SUPPLY SYSTEMS

Kewanee Water Supply System—Simonds Machinery Co., agents, 117 New Montgomery St., San Francisco.

Pacific Pump & Supply Company, 851-853 Folsom St., San Francisco.

Smith-Pooth-Usher Co., San Francisco and Los Angeles.

WATER HEATERS

Pittsburg Water Heater Co., 478 Sutter street, San Francisco.

WHEELBARROWS—STEEL

Western Iron Works, Beale and Main Sts., San Francisco.

WHITE CEMENT

"Medusa White," sold by Pacific Materials Co., Underwood Bldg., San Francisco.

WHITE ENAMEL

"Gold Seal," manufactured and sold by Bass-Hueter Paint Co. All principal Coast cities.

"Silkenwhite," made by W. P. Fuller & Co., San Francisco.

"Satinette," Standard Varnish Works, 55 Stevenson St., San Francisco.

WINDOW SHADES

W. & J. Sloane, 216-228 Sutter St., San Francisco.

WINDOW SASH CORD

Sampson Spot Cord, John T. Rowntree, Pacific Coast agents, San Francisco and Los Angeles.

WINDOWS, REVERSIBLE, CASEMENT, ETC.

Hauser Window Co., 157 Minna St., San Francisco.

The Kawneer Company, West Berkeley, California. (Simplex Fixtures.)

J. G. Wilson Corporation, 600 Metropolitan Bldg., Los Angeles; Waterhouse-Wilcox Co., Underwood Bldg., San Francisco.

WIRE FABRIC

U. S. Steel Products Co., Rialto Bldg., San Francisco.

Clinton Wire Lath, sold by L. O. Norris, 140 Townsend St., San Francisco.

WIRE FENCE

Standard Fence Co., 245 Market street, San Francisco; and 310 12th street, Oakland.

WOOD MANTELS

Fink & Schindler, 218 13th St., San Francisco.

Mangrum & Otter, 827 Mission St., San Francisco.

MOLINE HEAT

Hobart Building

San Francisco

TELEPHONE SUTTER 3818

MOTT PLUMBING FIXTURES

Architects and their clients are invited to visit our Showrooms, 553-555 Mission Street, San Francisco; D. H. Gulick, Sales Agent. Los Angeles Office, 1001 Central Building; J. R. Mayhew, Sales Agent.

Mott Company of California

MUELLER -- BRASS GOODS

Recognized as the Standard of excellence in plumbing. It pays to use them, and other Mueller Brass Goods. *The first cost is practically their last cost.*

H. Mueller Mfg. Co.

635 MISSION STREET, SAN FRANCISCO, CAL.

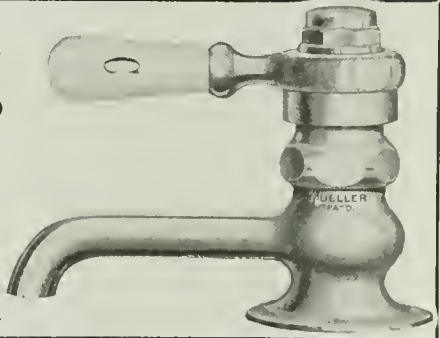

STORM KING and AMERICAN WARM AIR FURNACES

FURNACE FITTINGS AND REPAIRS

Montague Range & Furnace Company

327-329 JESSIE STREET

Phone Garfield 1422

826-830 MISSION STREET

SAN FRANCISCO, CALIF.

**DON'T NEGLECT YOUR HEATING SYSTEM.
THE BEST IS NONE TOO GOOD!**

All kinds of Galvanized Iron Work — Furnaces, Pipes, Ventilators — Sheet Metal for Planing Mills, Fruit Dryers, Rice Mills. Kitchen Equipment, including Steam Tables, Sinks, Canopies, Urn Stands, Etc.

JAMES A. NELSON

Heating and Ventilating Contractor

Phone, Garfield 1959

517-519 SIXTH ST., SAN FRANCISCO



Residence of Mrs. Thomas McDougall. N. Orange Grove Avenue, Pasadena California
 Architect—Harold H. Martin Builder—C. M. Hansen

At the end of the walk —

THERE is a subtle appeal to you to inspect this charming home at the end of the gravel walk. The attractive grounds do suggest a residence of this type to preserve the harmonious relationship between Nature's handiwork and man's labors.

THE impulse to walk in — to "see how the house looks," is due in no small measure to

FULLER'S PAINTS and VARNISHES

These products were used exclusively for the inviting interior, as well as the pleasing exterior of this beautiful Pasadena home.

W. P. FULLER & Co.

Since '49

MANUFACTURERS

Paints

Varnishes

**"CHICAGO"
SILENT
SIGNAL
HOSPITAL
SYSTEMS**

Garnett Young and Company

Pacific Coast Sales Engineers

612 Howard Street, San Francisco

SEATTLE

LOS ANGELES

PORTLAND

THERE is something Cheery about a White Cement House that appeals to the owner. Possibly that is why Stucco Homes have predominated in California in recent years.

DEL MONTE WHITE SAND

and

FAN SHELL BEACH SAND

used with a White Cement make a perfect stucco finish.

**DEL MONTE
PROPERTIES CO.**

401 Crocker Building

Phone Sutter 6130

San Francisco



OAK FLOORS

(For Everlasting Economy)



American Oak For American Homes

Mr. Architect, insure the continued satisfaction of your clients by specifying American Oak Flooring. A thorough investigation will convince any fair-minded professional man that it is superior in finish, grade and durability to any other.

The purchase of inferior Oak Flooring at low prices is a false economy against which you want to protect your clients.

Domestic vs. Foreign Oak

The low quality Japanese oak sold in this country is a poor substitute for the American. It not only lacks the grain or flower

which make American oak so beautiful, but it also lacks its strength.

It will be found to be very porous, breaking off evenly, which shows its brashy nature.

This trade-mark, stamped on every stick, is always a guarantee to you and to your clients of American-grown Oak Flooring of the highest quality.

This Association maintains its own inspection over every phase of air seasoning, kiln drying, milling and grading.

Insist upon its trade-mark when specifying Oak Floors.



Upon request we will mail booklets outlining our educational and other work for Oak Floors, which you will find interesting and valuable in the practice of your profession.

OAK FLOORING MERCHANTS' ASSN.
1036 Ashland Block, Chicago, Ill.



See page 389, Sweet's Catalogue, for specifications of various grades.



Brininstool

San - a - Cote

(GLOSS—Can be Scrubbed)

AN INTERIOR WALL FINISH

For bath rooms, kitchens, hospitals, schools, office and public buildings. Ask dealers, owners, architects and contractors about this durable, sanitary, washable, economical wall covering. Brininstool makes a paint for every purpose, and every can purposely good.

THE BRININSTOOL CO., LOS ANGELES

COLOR GRINDERS AND PAINT MANUFACTURERS

Distributors—The Brininstool Co., 1174 Phelan Bldg., San Francisco, Cal.; The Brininstool Co., 222 Abington Bldg., Portland, Ore.; Schutz Paint Co., Fresno, Cal.; Schneider, Chappell & Jones, Sacramento, Cal.; Salt Lake Glass & Paint Co., Salt Lake City, Utah; Griffin Paint Co., Ogden, Utah; Campbell Hardware Co., First and Madison Sts., Seattle, Wash.; Imperial Valley Hardware Co., El Centro, Calexico, Imperial, Brawley, Seeley, Cal.; Spokane Hardware Co., Spokane, Wash.; Continental Paint Company, 328 South First St., San Jose, Cal.; Los Angeles Wallpaper & Paint Co., 525 So. Main St., Los Angeles, Cal.; H. A. Berger, 3838 13th St., San Diego, Cal.; H. L. Christian, Blythe, Cal.; Ezra Thayer, Phoenix, Ariz.; Miami Lumber & Supply Co., Miami, Ariz.

RELIANCE BALL BEARING DOOR HANGERS

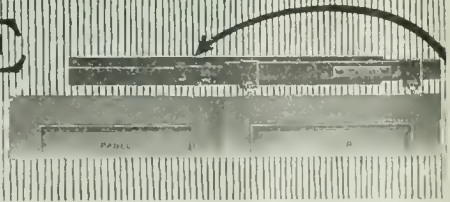

To get as near perfection as possible, use

RELIANCE "HANGERS" and "Reliance-Grant" Controllers

These insure fast service, practically noiseless and slamless doors.

Reliance-Grant Elevator Equipment Corp'n

PARK AVENUE AND 40TH STREET, NEW YORK

PACIFIC COAST AGENTS

Waterhouse-Wilcox Co.
Columbia Wire & Iron Works
D. E. Fryer & Company

San Francisco and Los Angeles, Cal.
Portland, Ore.
Seattle, Spokane, Tacoma, Wash. and Great Falls, Mont.

FOR ALL
FINISHING
REQUIREMENTS

THE
IMMACULATE
WHITE ENAMEL



STANDARD VARNISH WORKS

GENERAL OFFICES: NEW YORK - 90 WEST STREET
BRANCHES: LONDON - SAN FRANCISCO - PARIS - MELBOURNE

SAN FRANCISCO OFFICES & WAREHOUSE 55 STEVENSON STREET

When writing to Advertisers please mention this magazine.



The Charm of Color Harmony
in Roofing Tile

LOS ANGELES PRESSED BRICK CO.

“Varicolor”

“Varicolor” Roofing Tile

Wonderfully attractive effects, which contribute much to the beauty and charm of architecture, may be produced with “Varicolor,” Granada and Mission patterns in roofing tile as suggestive color illustration on opposite page.

The blending of the tile may be so handled as to produce the extreme in colors, or the conservative, according to individual preference. These tile are everlasting and the colors are burned through and through. The cost is but a trifle more than ordinary tile.

LOS ANGELES PRESSED BRICK CO.
MANUFACTURERS OF CLAY PRODUCTS
FROST BLDG., LOS ANGELES, CAL.

Bungalow Building Blox

Hollow Building Tile
Hollow Partition Tile

California Brick Co.

604 Mission Street
San Francisco, Cal.

BRICK

Red Ruffled Face Brick
Paving Brick
Step and Walk
Brick

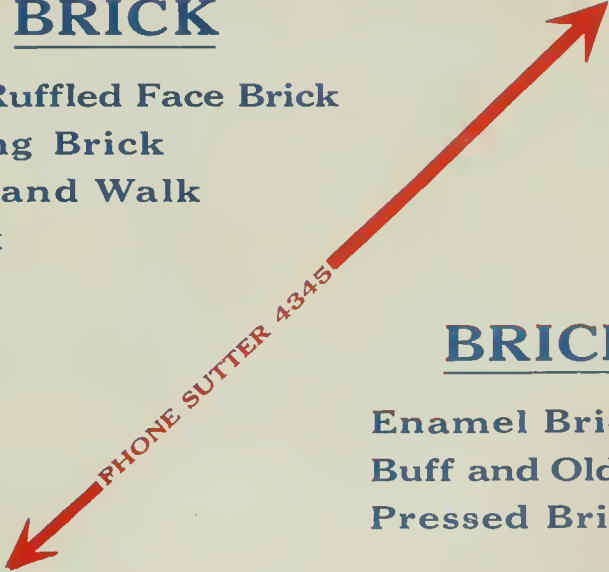

BRICK

Enamel Brick
Buff and Old Gold
Pressed Brick

Livermore Fire Brick Works

604 Mission Street
San Francisco, Cal.

Fire Brick and
Molded Fire Tile

Architectural Terra Cotta



FULLER & GOEPP

32 Page Street, San Francisco. Telephone Market 499
PRIVATE EXCHANGE CONNECTING ALL DEPARTMENTS

MANUFACTURERS OF

MIRRORS, ART AND LEADED GLASS

Dealers in **WHITE** Glass for Table Tops, Counter Tops, Sink
Backs & Etc. Complete Stock — Prompt Deliveries.

Passenger and Freight Elevators



"MADE IN SAN FRANCISCO"

Factory and Warehouse, 166-180 Seventh
Street, San Francisco. Phone Kearny 66

SPENCER ELEVATOR COMPANY



RA-DO^{FUMELESS} GAS RADIATORS

ALL CAST IRON—3 Sizes (3, 5, and 7 Sections)

The Ideal "Year-Round" Heating System
For The Home—New or Old

Easiest and Cheapest to Install
Lowest Operating Cost

BAIRD - BAILHACHE COMPANY
MANUFACTURERS

478 Sutter St., San Francisco

'Phone Sutter 6858

OLD MISSION PORTLAND CEMENT COMPANY



Each shipment of "OLD MISSION" Portland Cement is guaranteed not only to equal but to surpass all requirements of the standard specifications for Portland Cement as adopted by the U. S. Government and by the American Society for Testing Materials. A Guarantee Certificate is mailed with the bill of lading of each car, giving number of car, date packed, and number of barrels, over the signature of the chief chemist.

8000 SACKS DAILY

SALES OFFICE:

MILLS BLDG., SAN FRANCISCO

PHONE SUTTER 3075

PLANT:

SAN JUAN, CAL.

This new heat insulation not only
excels in durability and efficiency
as a steam pipe covering but

Insulex

is especially adaptable
to refrigeration practice.

AMERICAN INSULEX COMPANY
204 BERKELEY BANK BUILDING, BERKELEY Phone Berkeley 641



Keep Down Insurance Premiums

SPECIFY

SAINO FIRE DOORS

Standard Automatic Sliding or Swinging Fire Doors.
Tested and Labeled by the Underwriters' Laboratories.

STEEL SASH AND HOLLOW METAL
UNDERWRITERS WINDOWS

U. S. METAL PRODUCTS CO.

326-338 Tenth Street, San Francisco

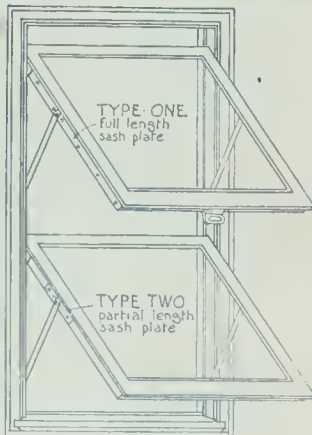

Hauser Reversible Windows

The Ideal Window is one that
will operate in any size frame—
wood or metal—the HAUSER
is such a window — easy to
install — a positive protection
against rain, dust and wind.

Hauser Window Company

OFFICE AND FACTORY
157 Minna St. (Phone Kearny 3706) San Francisco



Residence of Mr. Fred V. Kennon, Edgewood, Providence, R. I. Built 1915-1916. Mr. Thomas J. H. Peirce, Architect.
Twelve rooms; foundation 28x53 feet; two-car garage in rear

Unharmred by Storm or Stain

This interesting home overlooks Roger Williams Park in the outskirts of Providence. The specifications provided for a base and scratch coat of gray portland cement mortar on Clinton wire cloth. Over this is stucco (dash finish) of Medusa Waterproofed White Cement and light-colored bank sand. The face brick is also laid up with Medusa Waterproofed White Cement mortar.

The architect, Mr. Peirce, who is connected with the City of Providence Department of Public Buildings, has recently built a home for himself, using face brick laid in Medusa Waterproofed White Cement mortar.

Medusa Stainless White Cement not only helps you get the exact effect your plans call for while the building is still new, but assures *permanence* of results. Architects are cordially invited to ask for Medusa booklets and for information upon specific problems.

THE SANDUSKY CEMENT COMPANY
Department P CLEVELAND, OHIO

PACIFIC COAST DISTRIBUTORS:
Pacific Materials Co., San Francisco, Cal. Riverside Portland Cement Co., Los Angeles, Cal. A. McMillan & Co., Portland, Ore. Galbraith & Co., Seattle, Wash.



Detail of fireplace in living room.
Brick laid in Medusa Waterproofed
Stainless White Cement.

MEDUSA Stainless White Cement - *Waterproofed*

THE STANDARD OF QUAL



STOCK EXCHANGE BUILDING, LOS ANGELES

The two Office Buildings shown here were

*The Stock Exchange Building is faced
with Grey Enamel Brick and Terra Cotta*

LOS ANGELES PRESSED

ENTIRE SIXTH FLOOR, FROST BUILDING

ITY IN CLAY PRODUCTS



HOLLINGSWORTH BUILDING, LOS ANGELES

designed by Messrs. Morgan, Walls & Morgan

*The Hollingsworth Building is
faced with White Enamel Brick*

BRICK COMPANY =

SECOND and BROADWAY, LOS ANGELES

How daylight helps workmen do more and better work

DAYLIGHT and fresh air are powerful aids to production. The stimulus of plenty of light and fresh air is reflected in greater volume and accuracy of output, with diminished wastage. Operatives enjoy better health, are freer from eye-strain, lose fewer days through sickness. Labor turnover is reduced—output is noticeably increased. All of this is accomplished with TRUSCON Daylight Sash.

Truscon Daylight Engineers at your Service

All sizes of Truscon Steel Sash carried in stock in San Francisco Warehouse.

Largest stock of fireproof material and reinforcing bars on the Pacific Coast.

TRUSCON STEEL COMPANY

CHAS. HOLLOWAY, JR., Branch Manager

527 Tenth Street, San Francisco



TRUSCON DAYLIGHT SASH

Ford

THE ideal car for commercial purposes with its low cost of maintenance and operation.

For eighteen years we have catered to the wants of the Ford buying public.

We give you the benefits of a coastwise service.

William L. Hughson Co.

Since 1903

Prospect 607

Geary at Van Ness, San Francisco

Seattle

Portland

Oakland

Los Angeles

San Diego



**THE HOUSE
BEAUTIFUL**



THE interior of a Home should have those little touches of refinement that come with the co-operation of an experienced interior decorator.

CONSULT US

Decorative ideas, artistic framing, bybompa ware, floor lamps, table lamps, chair lamps, lamp shades, mirrors, candlesticks, decorated candles, book-ends, store window fixtures, odd furniture, pictures, Emma B. Freeman's Prints, pieces in unique colorings and indefinite carvings and other objects of art.

FREEMAN 'ART SHOP

386 SUTTER STREET
SAN FRANCISCO

Tel. Sutter 1593



Beach-Robinson Co.

Decorators and Furnishers

Carpets

Draperies

Furniture

Rugs

Wall Paper

Ransom E. Beach

239 Garry Street, 3d Floor

Union Square

Phone. Sutter 580

San Francisco, Cal.



ADD CHEER and COMFORT
to the Home by having a
WELL DESIGNED INTERIOR

Before Completing Your Plans, CONSULT

SONNENSCHN BROS.

INTERIOR DECORATORS

Furniture and Draperies Made to Order

Factory

718 NATOMA ST., Phone Market 1145

Show and Salesroom

470 SUTTER ST., Phone Kearny 2051



*The Finishing Touch
of Right Building —*

F. A. TAYLOR CO.

318 Stockton Street, San Francisco

Second Floor



Mercedes Bldg.

*Hand-made
Furniture,
Rugs,
Hangings,
Upholstering,
Decorating,
Wall Paper.*

The **GOLD MEDAL
MAIL CHUTE**



INSTALLED IN
THE NEW
SAN FRANCISCO
CITY HALL
AND THE
WHITE MARBLE
MERRITT
BUILDING.
LOS ANGELES

Given highest award at
Panama - Pacific Interna-
tional Exposition, 1915.

Waterhouse-Wilcox Co.

California
Representatives

**523 Market Street
SAN FRANCISCO**

**331 E. 4th Street.
LOS ANGELES**

**F. T. CROWE & CO.
Seattle, Wash.**

**THE J. McCracken Co.
Portland, Oregon**

**American Mailing
Device
Corporation**



**LIBERTY
WALL BOARD**

MANUFACTURED BY
KEY-HOLD PLASTER LATH COMPANY

A Fibered Gypsum Plaster that will not
shrink, warp or buckle.
Resists Fire, Moisture, Heat and Cold.
Key-hold plaster lath possesses a perfect
mechanical key—admitted for fire proof con-
struction in all classes of buildings.

KEY-HOLD PLASTER LATH CO.

Office and Factory
148 Hooper St. San Francisco
Phone Market 5767

McCRAY
**REFRIGERATORS
FOR ALL PURPOSES**

It is our particular desire to
impress the *Architects of
America* with the fact that
McCray builds refrigerators
for all purposes. Thousands
of fine residences, hotels,
clubs, restaurants, factory
cafeterias, hospitals, stores and
markets depend on McCray
for efficient, economical re-
frigerator service.

McCRAY REFRIGERATOR CO.
765 Mission Street, San Francisco, Calif.
Home Office and Factory
Keokuk, Iowa.

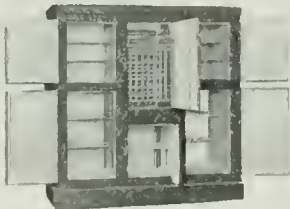

YOU KNOW that a building
should be watertight and
WE KNOW that it can be
made so with

**IMPERIAL
WATERPROOFING**

LOOK FOR  THE LABEL

If your building is leaking through
the walls or around the windows, or
if the Basement walls are wet below
ground — call up SUTTER 978.

IMPERIAL WATERPROOFING
is manufactured by BROOKS &
DOERR, 460 7th St., San Francisco

**WATEREX REED BAXTER
DISTRIBUTOR**

1002-04 Merchants National Bank Building,
Phone Sutter 978
SAN FRANCISCO, CAL.
3419 Broadway, OAKLAND, CAL.

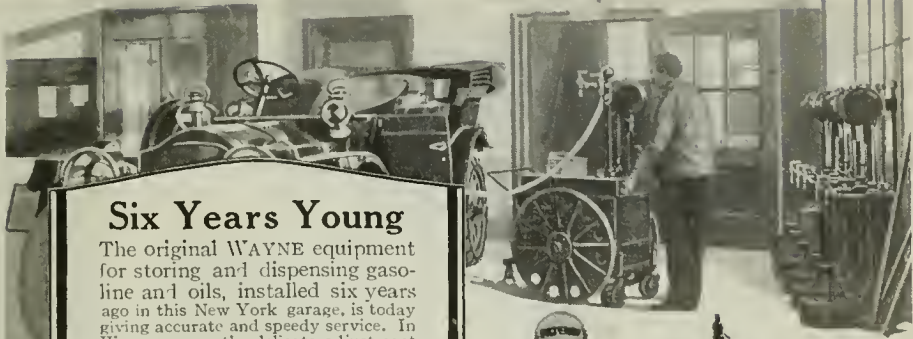

Six Years Young
 The original WAYNE equipment for storing and dispensing gasoline and oils, installed six years ago in this New York garage, is today giving accurate and speedy service. In Wayne pumps the delicate adjustment essential for accuracy is combined with a durability that assures satisfaction for years and years.
 There is a Wayne System for every need of the public garage. The service of Wayne engineers in advising and planning is yours without cost or obligation.

Wayne Oil Tank & Pump Co.
 746 Canal St., Ft. Wayne, Ind.

San Francisco Office Los Angeles Office
 631-633 Howard St. 830 S. Los Angeles St.
 Phone Garfield 1350 Phone Main 1600

Wayne
REG. U.S. PAT. OFF. TRADE MARK
Liquid Storage Systems



Cut No. 280
 One-gallon gasoline



Cut No. 230
 For Gas and Oil



Cut No. 200
 Lubricating oils

For the
 Exacting Client

Pitcher Hangers

Give Satisfaction

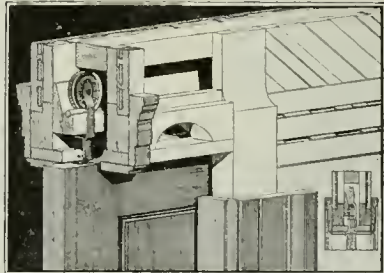

Smooth Running — Noiseless — Efficient
 Inexpensive

MANUFACTURED BY

NATIONAL MILL & LUMBER CO.

318 Market Street, San Francisco, Cal.

Telephone Kearny 3626



IT'S not enough to say "Good For All Time" unless there is something back of it. ¶ There is in this case. ¶ Vermont Marble already has an unblemished record of over one hundred and fifty years. ¶ We know what it will do. It's not necessary to guess at it. ¶ And our quarries in Alaska and Texas are also proving themselves. ¶ So please don't think of "Good for All Time" as merely a happy phrase.

IT'S THE MARK OF A SERVICE.
It means exactly what it says.

VERMONT MARBLE COMPANY
PROCTOR, VERMONT
San Francisco - Portland - Tacoma

A PROPRIETOR BOUND HIMSELF

to maintain fire insurance for the amount paid by him to the contractor as the construction of the building progressed. The building was burned while in course of construction and the company denied liability on the ground that the proprietor had no insurable interest. The court held that the proprietor had an insurable interest in the building equal to the amount paid to the contractor.

DIXWELL DAVENPORT
Manager Pacific Coast Department

**BANKERS & SHIPPERS
INSURANCE COMPANY**
INSURANCE EXCHANGE BLDG.
SAN FRANCISCO
Telephone Kearny 3561

A Bargain in Files—



HOLDS
20,000
letters. That's the capacity of this special four-drawer file, designed and built to meet the demand for steel storage at less than the price of high grade wood. See it today.

Van Dorn
**STEEL
EQUIPMENT**

Phone Douglas 1183

Western Office Equipment Co.
467 Market Street - San Francisco

CLINTON

WELDED WIRE
FABRIC AND LATH

The Perfect Support for Stucco and Interior Plaster. Complete Stock for Immediate Delivery. Steel Reinforcing Bars in Stock.

L. A. NORRIS CO.

140 Townsend Street

Phone Kearny 5375 San Francisco



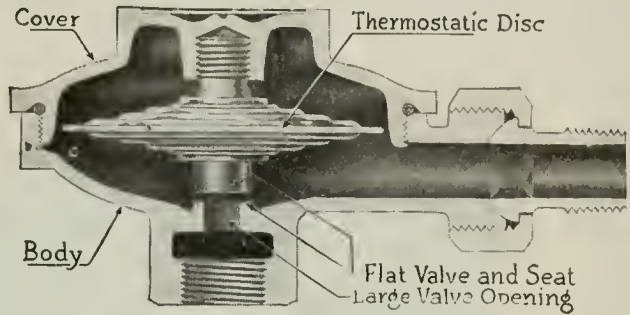

Cross-Section of No. 2 Trap

Be Emphatic

When you write your steam heating specifications be emphatic in your specification of the Dunham Radiator Trap. The builder may hesitate, but once you and the owner decide to get maximum heating comfort there can be no quibbling about the best way to get it. This way is fully described in "The Dunham Hand Book." Have you received your copy?

The DUNHAM
HEATING SERVICE

C. A. DUNHAM COMPANY

LOS ANGELES 600 Metropolitan Bldg. SAN FRANCISCO 524 Sheldon Bldg.

SEATTLE
206 First Ave. South

PORTLAND 410 Board of Trade Bldg. SPOKANE 405 Sherwood Bldg.

Administrative Office: CHICAGO, ILLINOIS



TAY PIPE
Valves & Fittings
STEAM & WATER SUPPLIES
Heating Material
PLUMBING GOODS
Pumps

GEORGE H. TAY COMPANY
SAN FRANCISCO OAKLAND
MISSION & SECOND STS. TENTH & HARRISON STS.
TELEPHONE DOUGLAS 2240 TELEPHONE LAKESIDE 4200

PERFECLITE
MANUFACTURING CO.

f

SEATTLE, WASHINGTON

TAKE PLEASURE IN ANNOUNCING
THE APPOINTMENT OF

MYERS & SCHWARTZ

AS EXCLUSIVE DISTRIBUTORS OF THEIR PRODUCTS
IN THE
STATE OF CALIFORNIA

75 NEW MONTGOMERY STREET
SAN FRANCISCO

1119 S. LOS ANGELES STREET
LOS ANGELES

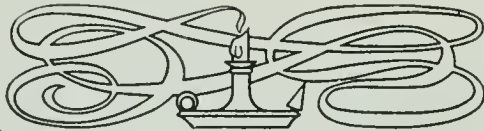

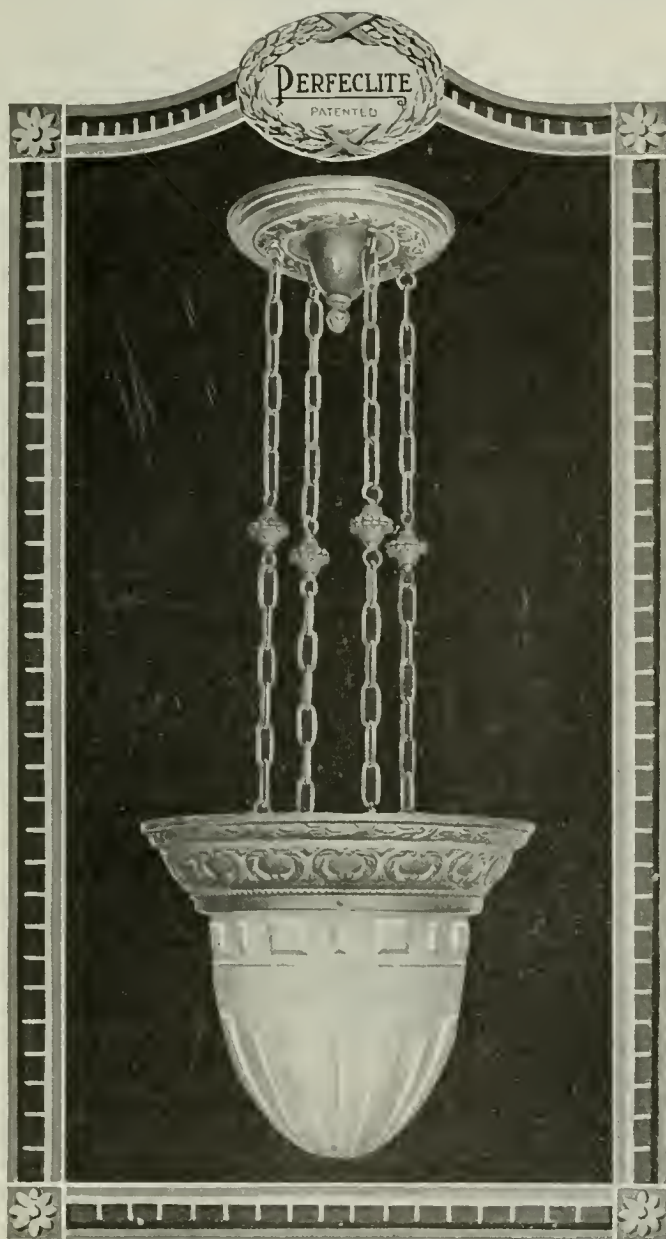

ILLUSTRATING ONE OF FORTY PERFECLITE DESIGNS

When writing to Advertisers please mention this magazine.

USE
UHL'S DIAMOND FLOOR WAX

1—3—5-lb. Cans. A Finishing Wax of best quality in Paste Form

UHL SEATTLE
OAKLAND
PORTLAND
LOS ANGELES
SAN FRANCISCO **BROS.**
 "WALL PAPER" - "PAINTS"

LEADER WATER SYSTEM

No country home is complete without this modern water system. Running water under pressure whenever and wherever needed. Convenient, economical, sanitary.

**Pacific Pump & Supply
 Company, Distributors**

851-853 Folsom Street
 SAN FRANCISCO, CALIF.

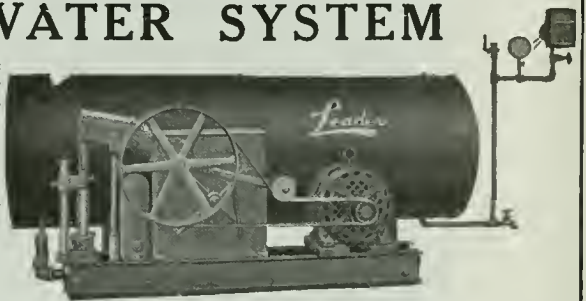

QUALITY HARDWARE



LOCKS AND BUILDERS'
 HARDWARE

PALACE HARDWARE CO.

"San Francisco's Leading Hardware Store"

581 MARKET STREET. SUTTER 6060



Pack your Radiator Valves with
Palmetto Twist Packing

It can be unstranded to fit any size valve. It does not get hard.

H. N. COOK BELTING CO.

401-433 Howard St.

San Francisco, Cal.

**WESTERN
VENETIAN BLINDS
WESTERN**

ELMINATE the unsightly awnings — Preserve the exterior beauty of your buildings by *Specifying*

**WESTERN VENETIAN
BLINDS**

Some 1920 contracts for complete equipment:

- 12-story Mattie Building,
Fresno, California
- 9-story Pantages Building,
Los Angeles, California
- 7-story Marland Refining Bldg.
Ponca City, Oklahoma
- 10-story Trademens Bank Bldg.
Oklahoma City, Okla.
- 5-story Railway Exchange,
Muskogee, Oklahoma



LOS ANGELES TRUST
AND SAVINGS BLDG.
LOS ANGELES, CAL.

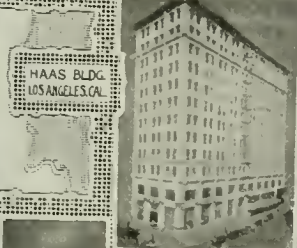

HAAS BLDG.
LOS ANGELES, CAL.



CITIZENS SAVING
BLDG.
PASADENA, CAL.



GLOBE GRAIN &
MILLING CO.
LOS ANGELES, CAL.



COUNTY COURT
HOUSE
WALLA WALLA, WASH.

When you consider the fact that **WESTERN VENETIAN BLINDS** take the place of both awning and window shade and will last practically as long as the building stands you'll realize that they are the logical equipment for modern buildings

WESTERN BLIND & SCREEN CO.
2704 LONG BEACH AVE.
LOS ANGELES CALIFORNIA

United States Steel Products Co.

Rialto Bldg., San Francisco

SELLERS of the products of the American Bridge Co., American Sheet and Tin Plate Co., American Steel and Wire Co., Carnegie Steel Co., Illinois Steel Co., National Tube Co., Lorain Steel Co., Shelby Steel Tube Co., Tennessee Coal, Iron and Railroad Co., Trenton Iron Co.

MANUFACTURERS OF

Structural Steel for Every Purpose—Bridges, Railway and Highway—"Triangle Mesh" Wire Concrete Reinforcement—Plain and Twisted Reinforcing Bars—Plates, Shapes and Sheets of Every Description—Rails, Splice Bars, Bolts, Nuts, etc.—Wrought Pipe, Trolley Poles—Frogs, Switches and Crossings for Steam Railway and Street Railway—"Shelby" Seamless Boiler Tubes and Mechanical Tubing—"Americore" and "Globe" Rubber Covered Wire and Cables—"Reliance" Weatherproof Copper and Iron Line Wire—"American" Wire Rope, Rail Bonds, Springs, Woven Wire Fencing and Poultry Netting—Tramways, etc.

United States Steel Products Co.

OFFICES AND WAREHOUSES AT

San Francisco - Los Angeles - Portland - Seattle



Accuracy and Safety with **BOWSER** Piston Type Measuring Pumps

Gasoline users demand Accurate Measurement and Safety from any danger of fire and explosion. The 35 years' consistent record of Accuracy and Safety of Bowser pumps fulfills this demand.

ACCURACY of Bowser pumps is determined positively by mechanical means. The Piston Type Pump is arranged to permit exactly the same amount to be repeatedly discharged.

SAFETY—There is no possibility of breakage or spilling of gasoline with Bowser pumps to endanger lives and property. There has never been a fire caused by a Bowser pump.

S. F. BOWSER & COMPANY, Inc.

FORT WAYNE, INDIANA

San Francisco Office: 612 HOWARD STREET



*Walls finished with Cabot's Old Virginia White
Roof finished with No. 36 Dark Gray Creosote Stain
Walter Boschen, Architect, St. Joseph, Mo.*

The soft, brilliant "whitewash white" of the Old Virginia White is particularly suitable for this type of house, and the rich greens and velvety dark gray stains harmonize perfectly for the roof, with the old New England dark green blinds.

Samples and information sent on request

SAMUEL CABOT, Inc., Mfg. Chemists, Boston, Mass.

Cabot's Creosote Stains, Waterproof Cement, and Brick Stain
"Quilt" Conservo Wood Preservative, Damp-Proofing
Protective Paints, Waterproofing, etc.

Pacific Materials Co., San Francisco
Waterhouse-Wilcox Co., Los Angeles

S. W. R. Dally, Seattle
Timms, Cress & Co., Portland
Theo. F. Snyder, San Diego, Cal.

The Latest Country-house Color-schemes

An especially appropriate and harmonious exterior color-treatment has been developed for the dignified and beautiful type of country-house that our leading architects have now firmly established, in place of the fifty-seven varieties that have prevailed in recent years.

Cabot's Old Virginia White,
for the walls

**Cabot's Creosote Stains, in
greens or dark gray, for the roofs**



CENTRAL HIGH SCHOOL, MINNEAPOLIS, MINN.

Architect, William B. Ittner

Contractors, Pike & Cook Co.

Glazed by Forman, Ford & Co

Completely equipped with American Window Glass Co.'s Double Strength AA Quality
First Choice of Leading Architects

Because of its absolute dependability, American Window Glass has been used in many fine buildings. Our care in inspection practically eliminates all imperfections and assures uniformity in thickness.

American Window Glass Co., General Office, Pittsburgh, Pa.

DOMESTIC SALES OFFICES

New York, 220 Fifth Avenue
Chicago, 1011 Peoples Gas Building
Boston, Mass., 43 Tremont Street
San Francisco, Cal., 341 Montgomery Street
St. Louis, Mo., 1303 Syndicate Trust Building
Memphis, Tenn., 440 North Main St.
New Orleans, La., 904 Hennen Bldg.
Atlanta, Ga., 1408 Candler Building

EXPORT SALES OFFICES

Havana, Cuba, Apartado No. 930
Buenos Aires, Argentina
Mexico City, Mex., Apartado Postal No. 237
Barranquilla, Colombia
Bogota, Colombia
Valparaiso, Chile
Lima, Peru
Toronto, Canada, 205 Continental Life Building



The above Trade-Mark appears on every light

Highest Quality

Finest Workmanship

Remco Redwood Tanks

Underwriters — Standard — Specials

All dimensions and capacities

Towers Designed and Erected

For Prices, Data or Estimates Phone GARFIELD 1910

Redwood Manufacturers Company

SOLE MAKERS

Hobart Building, San Francisco

When writing to Advertisers please mention this magazine.

JOHNSON'S ROTARY CRUDE OIL BURNER

Can be installed in any BOILER or FURNACE

Gives Satisfactory Results. Simple to Operate—
Automatic—Safe. Let us tell you more about this
Oil Burner.

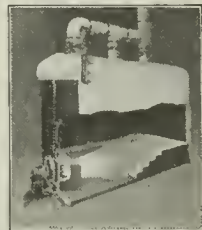

BURNER IN OPERATION

S. T. JOHNSON CO.

1337 Mission Street - San Francisco, Cal.

Ask for Bulletin No. 28 Phone Market 2759

Agencies: SEATTLE LOS ANGELES FRESNO SAN DIEGO SACRAMENTO
Member of the Oil Burners Manufacturers' Association of California.

Fess System Turbine Fuel Oil Burner

The latest word in the science of burning fuel
oil in an efficient and economical method

Ask for Bulletin No. 20

FESS SYSTEM CO., Inc.

1310 S. HILL ST.,
LOS ANGELES

218-220 Natoma Street, San Francisco

HOUSTON,
TEXAS

Member of the Oil Burners Manufacturers' Association of California.

OIL BURNER EQUIPMENTS

Low Pressure Air and Rotary Mechanical Atomizing Types

Refrigerating and Ice-Making Machines

Direct Expansion and Brine Circulating Systems

T. P. JARVIS MANUFACTURING CO.

CONTRACTING ENGINEERS AND MANUFACTURERS

275 Connecticut Street, San Francisco

Phone Market 3397

Member of the Oil Burners Manufacturers' Association of California.



TRADE MARK

Phone BERKELEY 6389

SIMPLICITY OF CONSTRUCTION together with
SUCCESSFUL and ECONOMIC OPERATION of

SIMPLEX BURNERS

reported by their many users, is the best recommenda-
tion we can furnish to those desiring crude oil burners.

American Standard Oil Burner

Company

FIFTH AND PARKER STREETS
BERKELEY, CALIFORNIA

Member of the Oil Burners Manufacturers' Association of California.



Pump Governors
Oil Burner Governors
Reducing Valves
Safety Valves
Oil Valves
Blowoff Valves
Boiler Feed Water
Regulators

Oil Pumping Sets
Little Giant Improved
Oil Burners
Duplex Oil Pumps
Rotary Oil Pumps
Oil Heaters
Draft Gauges
Boiler Feed Pumps

G. E. WITT CO., Inc.

ENGINEERS

Manufacturers and Distributors

862-864 HOWARD ST.

Phone Douglas 4404

SAN FRANCISCO, CAL.

NO DUST in Their Bread



LANGENDORF BAKING CO.

Nathaniel Blaisdell, Architect W. C. Duncan & Co., Contrs.

Dustproofed and wearproofed their floors
with *Vitri-fyx*.

PACIFIC MATERIALS CO.

525 Market St., San Francisco

A. F. EDWARDS, President
J. M. FABBRIS, Vice-President

J. A. MACKENZIE
Secretary

CHAS. F. EISELE } Asst. Managers
J. RUBIOLO }

AMERICAN MARBLE & MOSAIC CO.

25-29 Columbia Square, San Francisco

Telephone Market 5070

Factory on Canal, South San Francisco Telephone South San Francisco 161

DETROIT STEEL PRODUCTS CO., Detroit

Direct Factory Branch, 68 Post Street, San Francisco

Phone Sutter 125



The Architect and Engineer

CONTENTS FOR JANUARY, 1921

GARAGE FOR F. D. NAYLOR, STOCKTON, CALIFORNIA	Frontispiece
<i>Charles W. McCall, Architect</i>	
RECENT WORK BY CHARLES W. MCCALL, ARCHITECT	PAGE 47
<i>Irving F. Morrow</i>	
HOUSING SHORTAGE GROWING SERIOUS	61
FIGURES ON CONSTRUCTION COSTS	62
MR. MAYBECK'S SUGGESTION FOR A CALIFORNIA BRANCH, NATIONAL CONSERVATORY OF MUSIC AND ART	65
<i>Gilbert Moyle</i>	
PORTFOLIO OF RECENT CALIFORNIA ARCHITECTURE BY MORGAN, WALLS & MORGAN, O'BRIEN BROS., B. J. S. CAHILL AND S. HELMAN	67
THE PLANNING OF THEATRES AND AUDITORIUMS	81
<i>Edwin H. Flogg</i>	
COLLAPSE OF LONG BEACH CHURCH DOME	90
THE FLAT FEE AS A MEASURE OF EQUITY	92
<i>John Lawrence Mauran</i>	
NOTES ON RECENT DEVELOPMENTS IN CONCRETE	94
<i>Lieut.-Col. H. C. Boyden</i>	
COMPETITION FOR PLANS AND EQUIPMENT OF A MODEL KITCHEN	101
DEPARTMENT OF SAFETY	105
ELECTRICAL DEPARTMENT—THEATRE EQUIPMENT ON THE PACIFIC COAST	110
<i>Chas. Felix Butte</i>	

PUBLISHED MONTHLY BY

THE ARCHITECT AND ENGINEER, INC.
626-27 FOXCROFT BUILDING, SAN FRANCISCO

W. J. L. KIERULFF
President

FREDERICK W. JONES
Vice-President

L. B. PENHORWOOD
Secretary



GARAGE FOR F. D. NAYLOR, STOCKTON, CALIFORNIA
CHARLES W. McCALL, ARCHITECT

120.5
A 7224 64

162542 THE
ARCHITECT
AND
ENGINEER

Vol. LXIV

SAN FRANCISCO, JANUARY, 1921

No. 1

Recent Work by Charles W. McCall, Architect

By IRVING F. MORROW

QUIETLY, without ostentation, for some years past Mr. McCall has been building up an increasing volume of increasingly commendable architecture on both sides of San Francisco Bay and beyond. Mr. McCall's work embraces buildings of all types and sizes. Recently (May, 1920) we published with favorable notice an illustration of one of the largest of his efforts, the remodeled Robert Dollar building in San Francisco. Of this building we shall have more to say in a later issue. We show here plates of a few residential buildings and garages, typical of the spirit of Mr. McCall's work but by no means representative of his output.

Mr. McCall's work is well grounded in tradition, but never hampered by precedent. From the technical architectonic standpoint there is little that is strictly original; there is, on the other hand, almost always originality, and at least freshness, in the point of view. The composition is careful and unconfused. A penchant for the picturesque is well marked. It is, however, a picturesqueness which is strictly accountable to the simplicity, sobriety and common sense of the composition. Proportion is not infrequently distinctly felicitous, almost never displeasing. The scale of both elements and details is usually just; where questionable the error is apt to be on the side of smallness rather than of exaggeration. As a result Mr. McCall's work is never coarse or crude; although it may sometimes exhibit a tendency toward prettiness, which, however, rarely degenerates into sheer pettiness. The taste is sensitive and disciplined, at best distinctly charming, never offensive. The color effects, which have eluded the camera, are often piquant and ingenious. All told, Mr. McCall's work is dignified, varied, unprejudiced, unquestionably an asset to the community. Though it be neither unusually brilliant, nor strikingly original, his personal mark is unmistakably upon it. He derives, it would appear, a quiet but genuine pleasure from the doing of his work; and he is assuredly entitled to an equally calm satisfaction in his achievement.

Despite his obvious liking for the picturesque and his understanding of it, Mr. McCall is never more fortunate than in houses of the quasi-formal type, such as the Alberger residence on page 50 of this issue, and the house shown on page 53 of that of October, 1920. Although severely balanced as to plan and mass, the compositions display a freedom of handling which dispels any tendency toward formalism, and is in itself, in fact, a subtle kind of picturesqueness. The more freely treated compositions are occasionally



LIBRARY HOUSE FOR MR. J. A. MONROE
Charles W. McCall, Architect

marred by an anomaly like the weakened corner on the Clarke house on page 51 of this issue. With the garages from Oakland and Stockton here shown Mr. McCall has been particularly successful. He has fully recognized the necessity for huge yawning openings in such buildings, but at the same time he has overcome the appearance of emptiness and structural

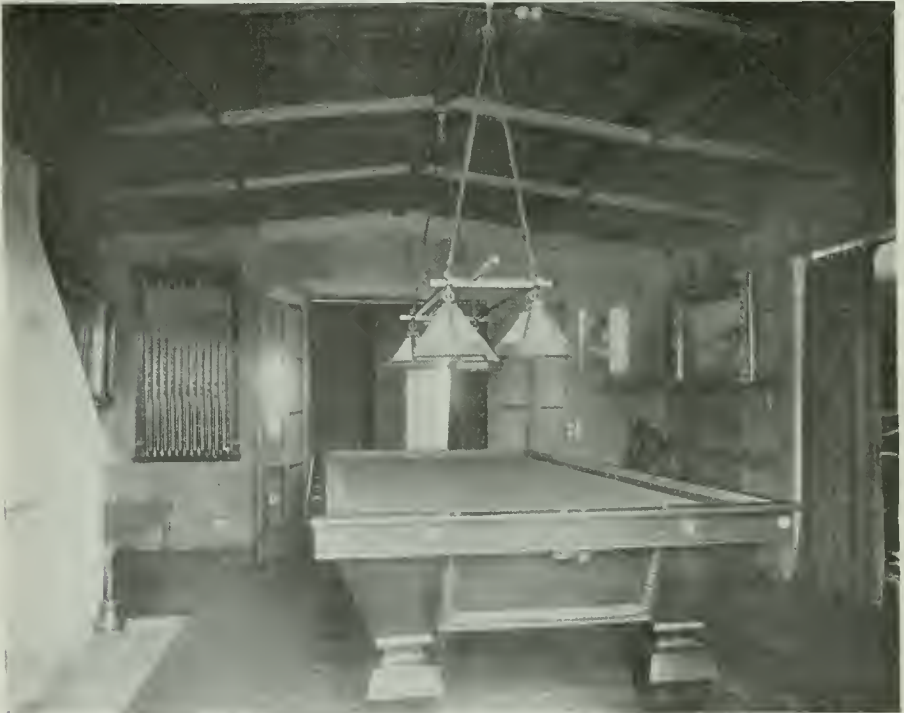

BILLIARD ROOM, HOUSE FOR MR. JAMES TYSON
Charles W. McCall, Architect



SHOW ROOM, GARAGE FOR F. D. NAYLOR, STOCKTON, CALIFORNIA
Charles W. McCall, Architect

inadequacy generally so obtrusive. They are, in addition, invested with a charm of design not inappropriate to, but rarely found in industrial buildings. San Francisco's automobile row contains many buildings of greater size and importance, but probably none of equal merit from the human point of view.



TOWER ROOM, HOUSE IN SAN FRANCISCO
Charles W. McCall, Architect



HOUSE FOR MR. W. R. ALBERGER, PIEDMONT, CALIFORNIA
CHARLES W. McCALL, ARCHITECT

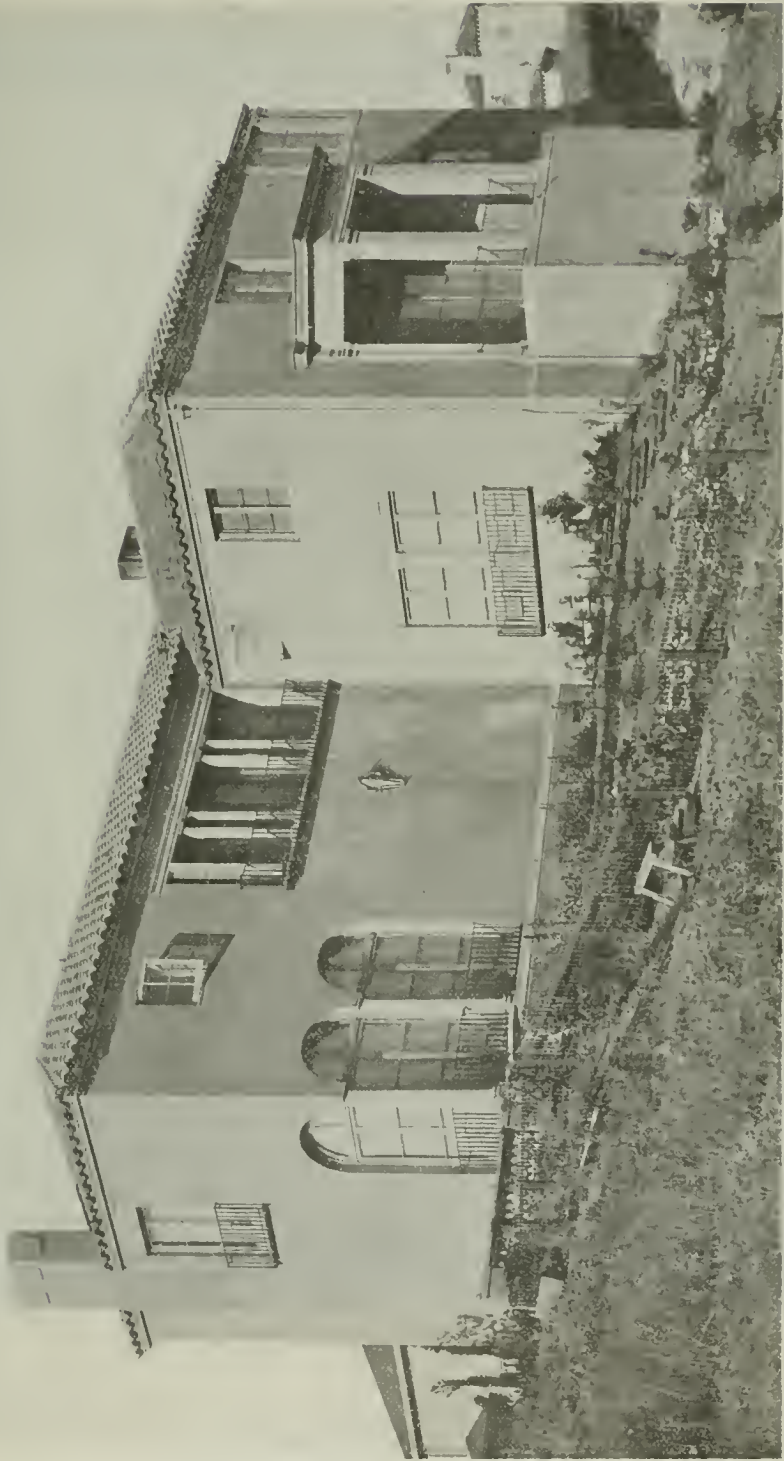

HOUSE FOR DR. AUSTIN CLARKE, OAKLAND, CALIFORNIA
CHARLES W. McCALL, ARCHITECT



LIVING ROOM, HOUSE FOR DR. AUSTIN CLARKE, OAKLAND,
CALIFORNIA. CHARLES W. McCALL, ARCHITECT



HALL, HOUSE FOR DR. AUSTIN CLARKE, OAKLAND,
CALIFORNIA. CHARLES W. McCALL, ARCHITECT



ENTRANCE, HOUSE FOR DR. AUSTIN CLARKE, OAKLAND,
CALIFORNIA. CHARLES W. McCALL, ARCHITECT



ENTRANCE, HOUSE FOR MR. CHARLES W. GARDNER, OAKLAND,
CALIFORNIA. CHARLES W. McCALL, ARCHITECT

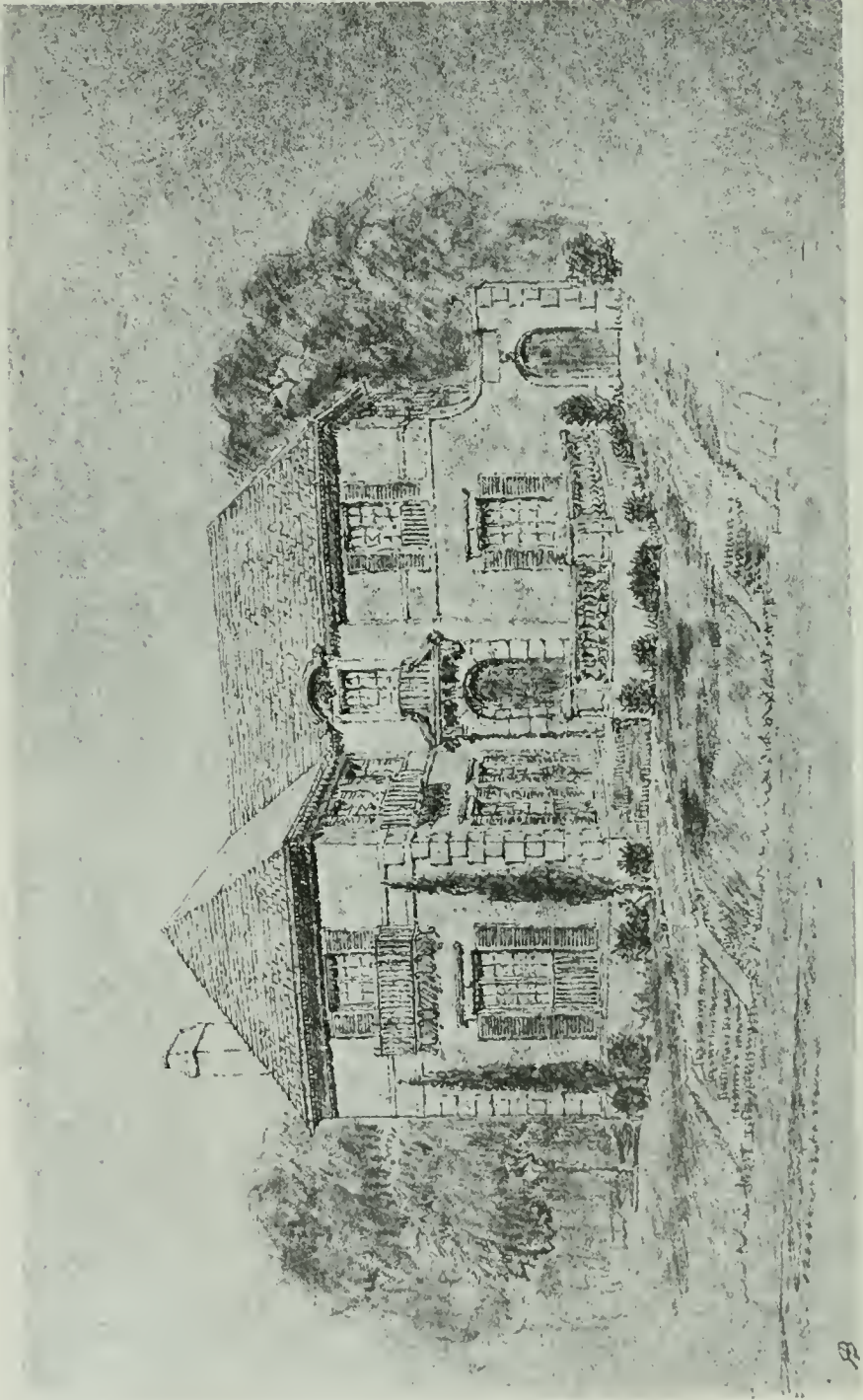

DESIGN FOR A HOUSE IN OAKLAND, CALIFORNIA
CHARLES W. McCALL, ARCHITECT

22

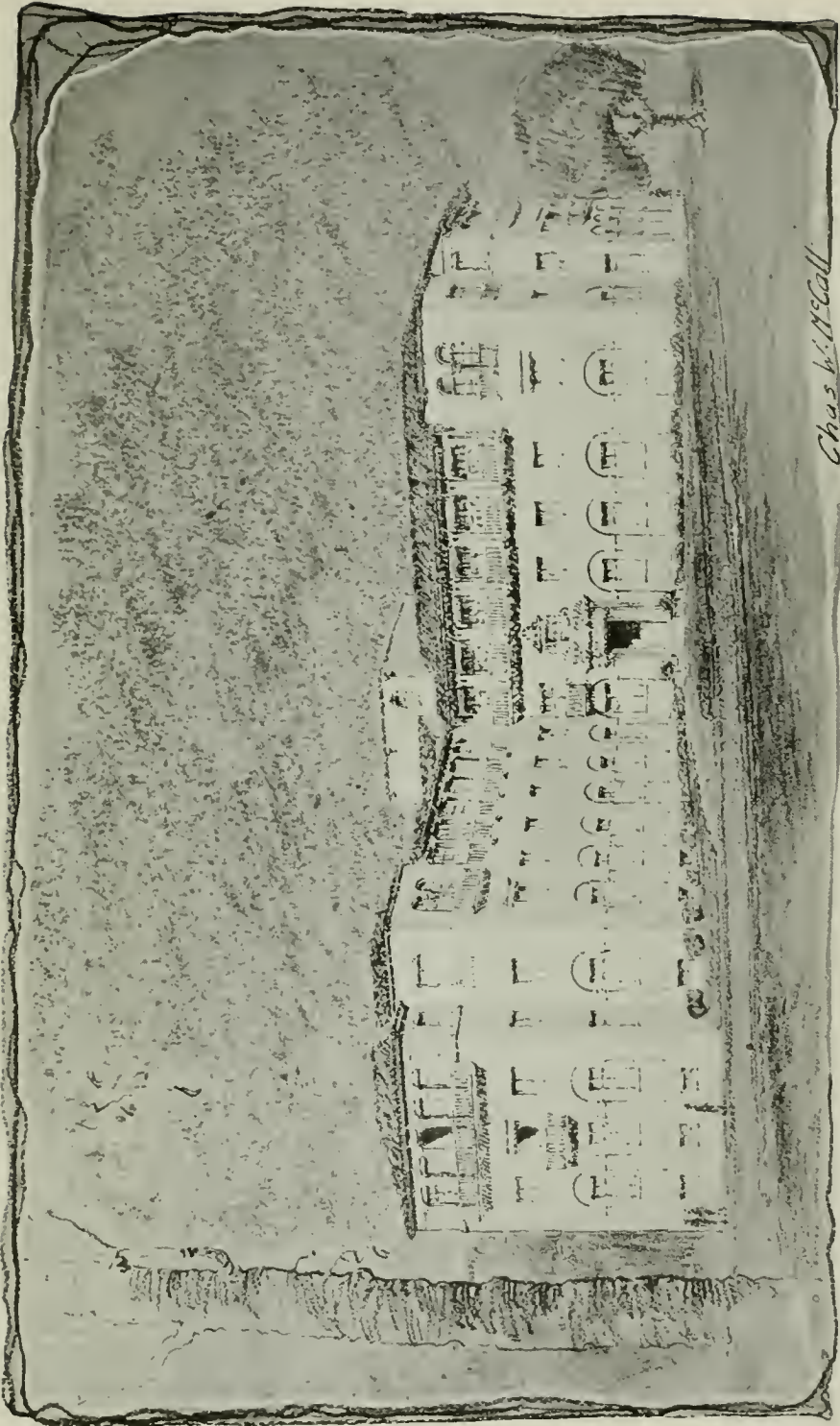

Chas. W. McCall

DESIGN FOR AN APARTMENT HOUSE, OAKLAND, CALIFORNIA
CHARLES W. McCALL, ARCHITECT



GARAGE FOR F. D. NAYLOR, STOCKTON, CALIFORNIA
CHARLES W. McCALL, ARCHITECT



OAKLAND GARAGE, OAKLAND, CALIFORNIA
CHARLES W. McCALL, ARCHITECT

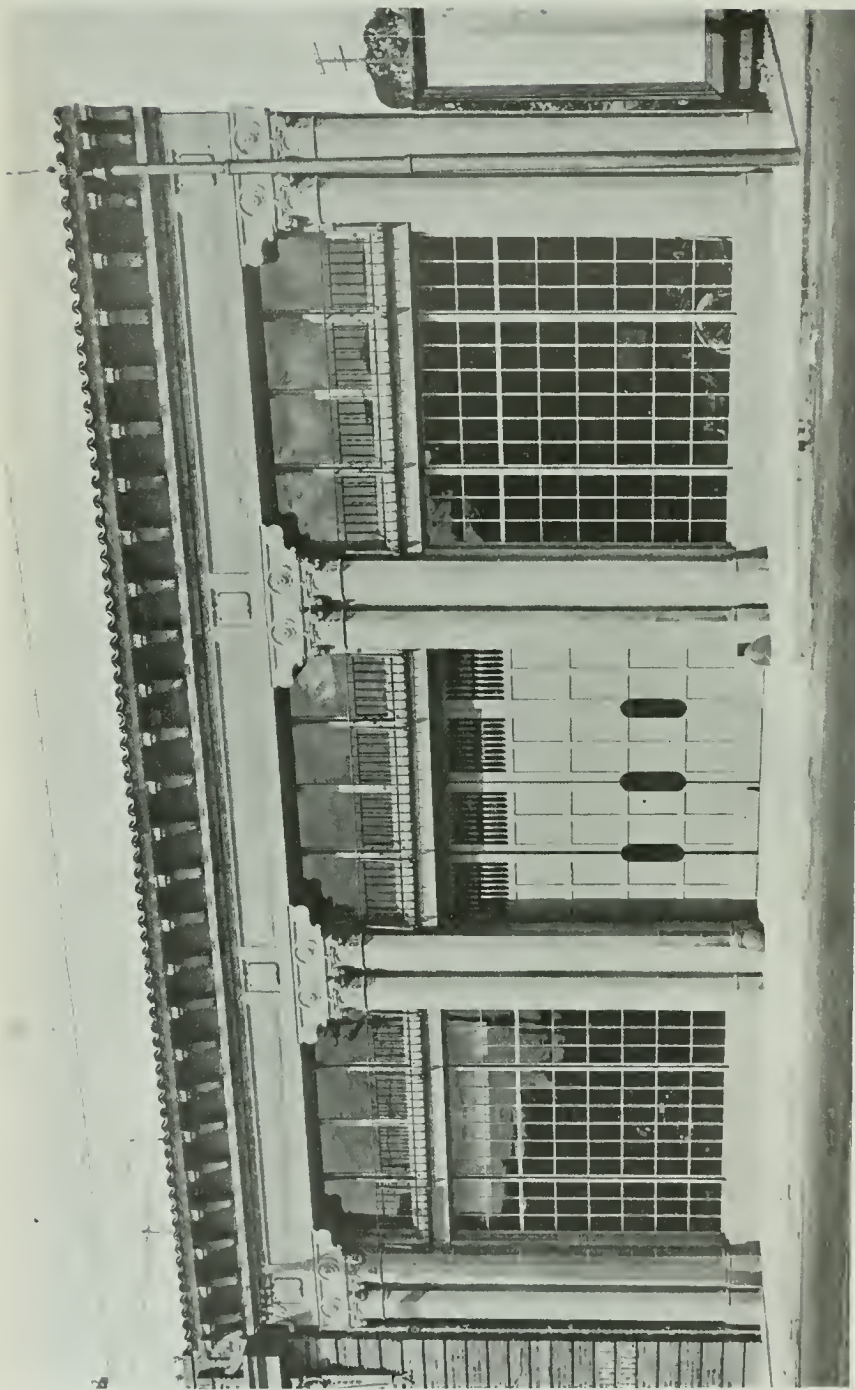

GARAGE, PIEDMONT, CALIFORNIA
CHARLES W. McCALL, ARCHITECT

Housing Shortage Growing Serious

ESTIMATES placing the shortage of houses in America at more than 1,250,000 will be placed before the National Council of the Chamber of Commerce of the United States at a meeting to be held in Washington January 27 and 28, which will discuss measures to relieve the situation.

The housing shortage, according to John Ihlder, manager of the National Chamber's Civic Development Department, has reached a point where four million persons are inadequately housed. Mr. Ihlder is helping in the preparation of a program for the conference, which will bring representatives of the 1,400 industrial and commercial organizations making up the National Chamber's membership. He has made a close study of the housing problem.

"For a number of years prior to the World War," said Mr. Ihlder today, "it is conservatively estimated that there are erected in the United States between 350,000 and 400,000 family dwellings in a year. This includes homes and apartments. During the war construction of houses was practically at a standstill, with the exception of what building was done by the Government. As a result of this we came out of the war far behind our regular building program. The situation has not improved a great deal since the signing of the armistice except for a brief spurt early in 1919, because those who contemplated building homes put it off until prices should become stabilized.

"In 1919 it is estimated that there were built only about 70,000 houses in the United States, while the number erected during 1920 will probably turn out to have been even smaller than that figure.

"While it is true there are many houses for sale, these are nearly all now occupied by tenants. The number of houses for rent in most communities is practically nil and the majority of these houses are not suitable for the needs of the average wage earner. A man with an income of \$5,000 a year or more doesn't have as much trouble getting desirable quarters as the wage earner who cannot afford to pay high rents. The wage earner and those earning small salaries are the ones who are hit hardest by the housing shortage. It is for these folks that decent homes must be built.

"Meanwhile they, as well as many with larger incomes, are doubling up or taking in lodgers. Increased rents, too, have caused many families to share their quarters with outsiders, so we have the anomaly of a block or an apartment house containing a larger number of people than it ever did in the past, yet with an occasional house or apartment vacant, because those needing better quarters can't afford to pay any higher rents. This overcrowding of rooms is viewed with anxiety by the public health officials who realize how infectious diseases spread under such conditions.

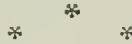

Fireproofing Wood

A process has been made public in England by which timber is made fireproof, according to Scientific American. It consists in submitting the wood in a closed cylinder to a steaming and vacuum treatment, which removes the air and moisture in the pores of the wood and vaporizes the sap water. The wood is then impregnated under hydraulic pressure with a solution of fire-resisting chemicals, which replaces the elements driven out by the preliminary treatment. Finally the water of the solution is dried

off, and the chemicals in minute crystal form remain embedded in the fibers. The effect of this treatment is explained as being that on the application of heat the crystals expand and form a glossy coating, which excludes the oxygen of the air and prevents its combination with the wood, thus rendering flame an impossibility. The higher the temperature, the more the crystals expand, and though in time the chemical action of each crystal becomes exhausted and the wood becomes charred, fresh crystals come into play, and though the wood may eventually be charred completely through, no flame will be generated. Wood treated in this way does not differ in appearance from wood that has not been treated, and it is claimed that it does not corrode nails or screws.—Engineer and Contractor.

* * *

Figures on Construction Costs—Actual Competitive Bids Taken by Architects, Show Trend from 1917 to 1920

IN a recent issue of the Monthly Bulletin of the Illinois Society of Architects, the president of the society, Mr. F. E. Davidson, of Davidson & Weiss, architects, Chicago, presented some interesting figures on construction costs as reflected in actual competitive bids submitted on the trades mentioned for a four story and basement Standard Mill Sprinklered Warehouse Building in Chicago, from plans prepared in the office of Messrs. Davidson & Weiss. This building was designed in accordance with the building code of Chicago for a live load of 200 pounds per square foot. The building was to be equipped with a dry pipe sprinkler system. The heating system was to provide heat in the basement, the office section, toilet rooms and for the gravity tank only. Only eight toilet fixtures were provided for in the plumbing system.

"A careful analysis of the estimates for the different classes of work will result in some interesting conclusions," says the Bulletin. "Particular attention is called to the trend in prices for cut stone, sheet metal, hollow metal doors, elevator doors, glazing, painting, plumbing and heating.

"At the time the original proposals were received the owner, while possessing ample funds to build, and was in need of the structure, was of the opinion that the estimates submitted were entirely too high and deferred construction, hoping that costs would be reduced. At various times, as outlined in the schedule, the work was again estimated with the results indicated":

	Aug. 29, 1917.	June 18, 1918.	June 18, 1919.	Sept. 15, 1919.	Feb. 3, 1920.	Nov. 9, 1920.
Masonry, carpentry and concrete	\$98,783.00	\$119,283.00	\$136,700.00	\$155,532.00	\$213,000.00	\$207,000.00
Structural steel and miscel. iron..	13,468.00	15,400.00	16,300.00	16,300.00	21,535.00	19,665.00
Cut stone	1,195.00	1,965.00	2,438.00	2,792.00	3,748.00	4,970.00
Sheet metal	240.00	282.00	360.00	360.00	475.00	807.00
Hollow metal stair doors.....	2,100.00	2,135.00	2,121.00	2,121.00	2,522.00	3,450.00
Elevator doors	2,400.00	2,450.00	2,580.00	2,880.00	3,700.00	4,570.00
Fire escapes	2,428.00	2,428.00	2,381.00	2,518.00	2,923.00	2,923.00
Plastering	525.00	550.00	570.00	665.00	833.00	1,000.00
Glazing	1,820.00	1,645.00	1,526.00	1,681.00	2,524.00	2,919.00
Roofing	1,192.00	1,240.00	1,380.00	1,640.00	2,000.00	2,580.00
Vault doors	185.00	220.00	250.00	260.00	265.00	290.00
Painting	2,593.00	3,140.00	3,412.00	3,712.00	4,327.00	5,200.00
Plumbing	5,355.00	5,782.00	6,054.00	6,654.00	8,538.00	10,040.00
Elevators	4,740.00	4,800.00	4,900.00	5,100.00	6,450.00	6,700.00
Heating	4,000.00	4,300.00	4,500.00	4,800.00	6,500.00	8,000.00
Electric wiring	2,000.00	2,000.00	2,000.00	2,400.00	3,000.00	3,400.00
Sprinklers	17,500.00	17,500.00	18,000.00	18,900.00	23,187.00	23,187.00
Hardware	500.00	520.00	560.00	575.00	800.00	875.00
Total	\$161,024.00	\$185,640.00	\$206,032.00	\$228,890.00	\$308,327.00	\$307,576.00
Cost per sq. ft.....	\$1.46	\$1.68	\$1.87	\$2.07	\$2.80	\$2.79
Cost per cu. ft.....	.097	.114	.124	.132	.187	.186
Increase over 1917.....		15%	28%	41%	92%	91%

The "Individual" Element

WE most earnestly commend to the careful consideration of every reader of this magazine the thought involved in the following excerpt from the Financial and Business Summary of the Citizens National Bank, of Los Angeles:

Nearly everything in the zone of business today hinges upon the sincerity of the interest that the individual takes in the performance of his duties. All occupations are suffering from the indifference of the bulk of their operatives. Both men and women workers do not seem to see that the losses their neglect and half-hearted work entail bulks to a terrific total which is projected directly against their own comfort. Many have more regret over the loss of a dollar than they have over a loss of the consciousness of duty. The real fact of the matter today is that this country is in far greater danger of a self-indulgence panic than it is of a money panic. Safety, prosperity and the ability to enjoy more fully the privileges of the present advancement of civilization are each wrapped in the desire to serve in the manner that the individual himself would be served. Such a belief PRACTICED makes one first worthy of prosperity, then presents him with it and protects him in it.

Once we can get a general acceptance of the fact—and it is a fact beyond dispute—that "safety, prosperity, and the ability to enjoy more fully the privileges of the present advancement of civilization are each wrapped in the desire to serve in the manner that the individual himself would be served," we shall have advanced far toward a satisfactory solution of our economic problems. It is because of this fact that our appeal almost invariably is to the individual rather than to the mass.

Each one of us must come to feel individual responsibility for existing conditions and to practice individual effort to bring about a change in these conditions. Progress lies along the way of individual consciousness and effort, not along the way of mass consciousness and effort. The "individual element" always has held, holds now and always will hold the secret of human advancement, morally, socially, and economically.—Valve World.

* * *

Office Hours of New York City Architects

The range of office hours for important New York City engineering and construction firms and architects, was recently the subject of a brief investigation by the Merchants' Association's Industrial Bureau of New York City. Of eight architects' offices investigated, all open at 9 o'clock and close at 5 daily, closing at 1 o'clock on Saturday. In some cases this is varied during the summer months: One firm opens at 8:30 and closes at 5:30 daily for five days, remaining closed all day Saturday; another firm retains its winter hours five days a week, but remains closed all day Saturday; still another firm closes at 12 o'clock instead of 1 on Saturdays. Of twelve engineering and construction firms investigated, seven have hours from 9 to 5 daily (five of these seven close at 1 on Saturday, one at 12, and one at 12 or 12:30), one opens daily at 9 and closes at 5 or 5:30 (closing Saturdays at 12 or 1), two open at 8:30 and close at 5:30 daily (one closing at 1 o'clock and one at 12:30 Saturdays), another opens at 8:45 and closes daily at 5:15 (closing at 1 on Saturday), and still another opens at 8 and closes daily at 5:30 (closing at 2 on Saturday).

* * *

Women Study Architecture

Two women are majoring in architecture at the University of Oregon, Eugene. They are specializing in design and domestic architecture instead of construction work. This will lead to interior and exterior decorating, floor plans and structural design.

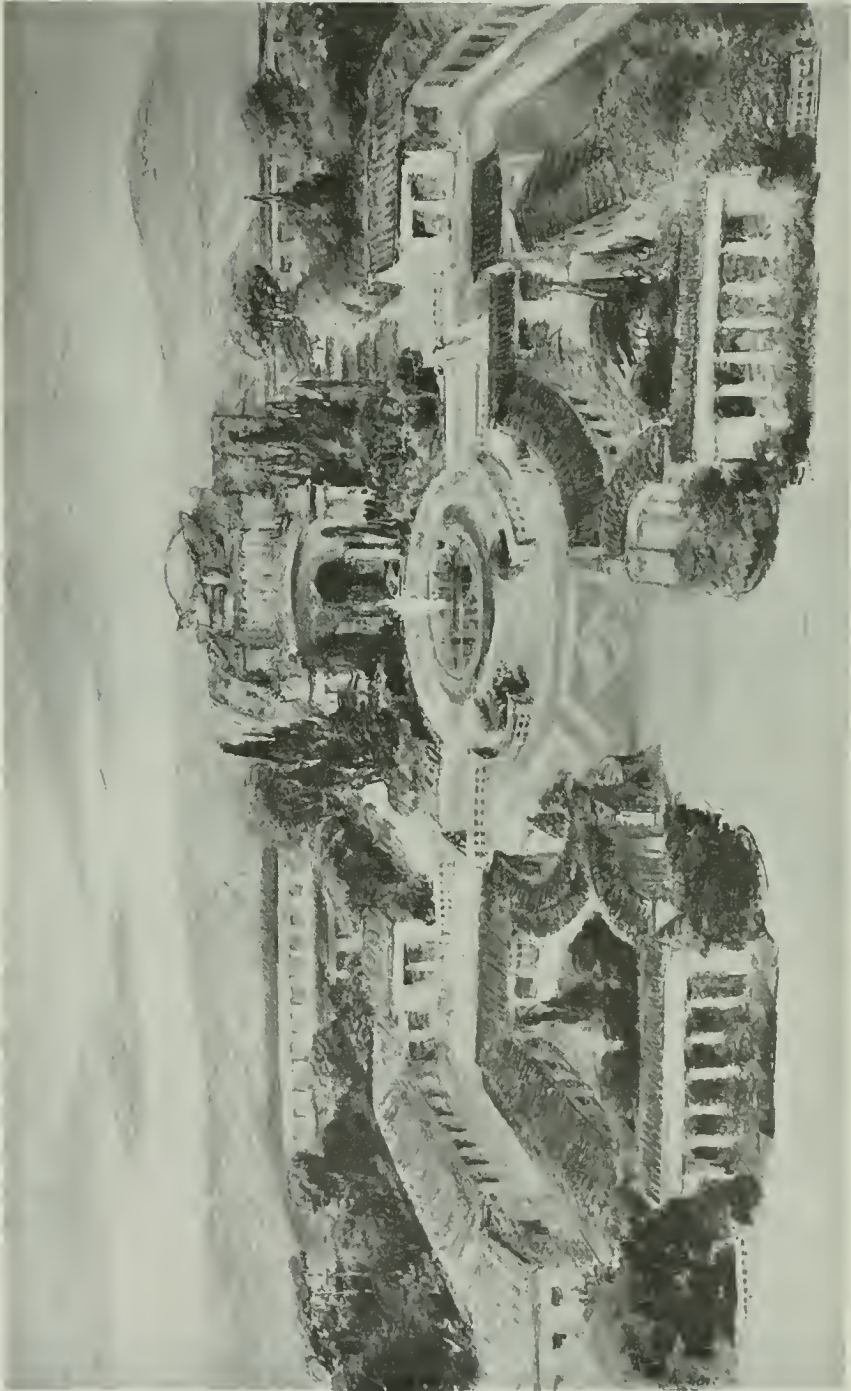

SUGGESTION FOR GROUP OF BUILDINGS FOR THE CALIFORNIA BRANCH NATIONAL CONSERVATORY OF MUSIC AND ART. BERNARD R. MAYBECK, ARCHITECT

Mr. Maybeck's Suggestion for a California Branch of the National Conservatory of Music and Art

By GILBERT MOYLE.

A DEPARTMENT of Fine Arts, with a secretary in the president's cabinet, is provided for in the Fletcher Bill now pending in Congress. The bill further provides for the establishment of a National Conservatory of Music and Art to consist of five branches of equal standard, one of which would be located in the District of Columbia, the second in Florida, the third in the City of New York, the fourth in Chicago, and the fifth in California "in or about Los Angeles or in or about San Francisco."

A mutual interest in the fine arts led to a series of discussions between the writer and Bernard R. Maybeck, architect of the Palace of Fine Arts, concerning the California branch of the proposed conservatory. One day, when the conversation had drifted to the character of the building or buildings to house the institution, Mr. Maybeck found it necessary to illustrate his remarks with a piece of chalk. As the conversation progressed the sketch grew until it developed into the basis of the accompanying drawing, which, like the original, is a free-hand study subject to modification as the detail is worked out. A brilliant color scheme would supplant the plain black and white necessary for reproduction purposes.

The drawing has been shown to various groups of widely different professions—painters, poets, musicians, laymen and politicians—and the response has been immediate and unanimous. They were one in pronouncing it an inspiration. Seeming at first glance purely idealistic, on closer examination it is found to be the most practical kind of a structure.

First, it is California! It could not be found in New York or Chicago. It proclaims to the world the spaciousness and grandeur of the Golden State and her serene and incomparable loveliness. The New England Conservatory, familiar to architects, with the traditions of the Pilgrims and the heroic years of the Revolution for inspiration, nevertheless falls so far short of what was possible that it might belong with equal ease to Philadelphia or Denver, or, for that matter, to London or Berlin. OUR conservatory, on the other hand, would epitomize the history of California and express in one majestic chord of "frozen music" the glory of her golden days, past and to come.

The central building contains a small auditorium for lectures, recitals, etc. The stage serves a double purpose, opening on occasion upon a large outdoor theatre (shown in the center) where thousands might gather. The studios are in the buttressed walls. They are together and yet apart. They provide what a conservatory most needs—solitude in a crowd. Their arrangement has met with the particular approval of musicians who are familiar with the drawbacks of the customary close quarters of studio buildings.

An active campaign is now being conducted throughout the country for the establishment of the Department of Fine Arts and the National Conservatory. Before the war it was estimated that 10,000 American students studied abroad. It was not so much the cost that was objected to, though that was considerable, but the fact that these students returned with foreign ideals that impaired or nullified attempts to establish a culture of our own. The conservatory would prevent a recurrence of that condition. It is a legitimate part of the reconstruction program. California is first in the field with a definite plan for a particular site.

Lumber Selling Below Cost

“**M**ANUFACTURERS of Southern pine are very anxious to do what they can to assist in bringing about those conditions which will make possible the resumption of building activities with the coming of the building season of next spring,” said Mr. J. E. Rhodes, secretary-manager of the Southern Pine Association, at the Lumbermen's Club of New Orleans recently.

“Lumber is taking its share of the liquidation now going on in all lines of industry,” declared Mr. Rhodes, “the average price of Southern Pine at the mill having declined 51 per cent from the price which prevailed in March last. At that time there was a wild scramble for lumber, several buyers bidding against each other for each board. Since April there has been a marked decline each month until now the wholesale price has gone down below cost of production of the average mill. As a result, many hundreds of the smaller mills have ceased operations, and the larger mills, which are anxious to keep their crews together, are operating at reduced time. The curtailment of output is about 45 per cent below normal.

“The demand for lumber has not been as light as it is now in recent years,” said Mr. Rhodes, “being about 22 per cent below what the mills are actually producing. The total production reported by members of the Southern Pine Association during November was 235,196,175 feet, as compared with 450,000,000 feet November a year ago.

“Lumber is not independent of other building materials, the prices of which must come down before building can proceed. Reductions have been made in structural steel, cement, clay products, roofing, etc.” Mr. Rhodes states that the retail lumbermen of the country are reducing retail prices of lumber and other materials as rapidly as they can in view of the amount of high priced material which some of them have in their yards.

* * *

Book Paper from Southern Pine and Red Gum

The possibility of using southern pine and red gum for the production of high-grade book and magazine paper has been demonstrated in recent trials at the U. S. Forest Products Laboratory, Madison, Wis. Book paper requires for its manufacture two kinds of woods—a long-fibered wood, such as spruce, to impart strength, and some short-fibered hardwood to give the formation, finish, opacity, and other printing qualities. The southern pines are long-fibered woods, excellently suited for the manufacture of wrapping paper and fiber board, but their pitch content and the difficulty of bleaching them have heretofore been obstacles in the way of their use for white paper. These obstacles, it has been shown, can be overcome in a large measure by the proper cooking conditions and improved bleaching methods. Red gum is typical of many southern hardwoods that might be used with the pines in the manufacture of the better grades of printing paper.

The laboratory experiments indicate that one cord each of loblolly pine and red gum are capable of yielding one ton of paper, at a cost which should allow a good profit under prevailing conditions. The utilization of the southern pines for book paper would spread the burden of the pulpwood supply over considerable territory which is favored with a large annual growth of timber.

Portfolio of Recent California Architecture

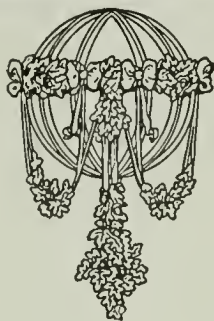

By

Morgan, Walls & Morgan
Los Angeles

O'Brien Bros.
San Francisco

S. Heiman
San Francisco

B. J. S. Cahill
Oakland



SAVOY HOTEL, LOS ANGELES. MORGAN,
WALLS & MORGAN,
ARCHITECTS



HOLLENBECK HOME FOR AGED PEOPLE, LOS ANGELES
MORGAN, WALLS & MORGAN, ARCHITECTS

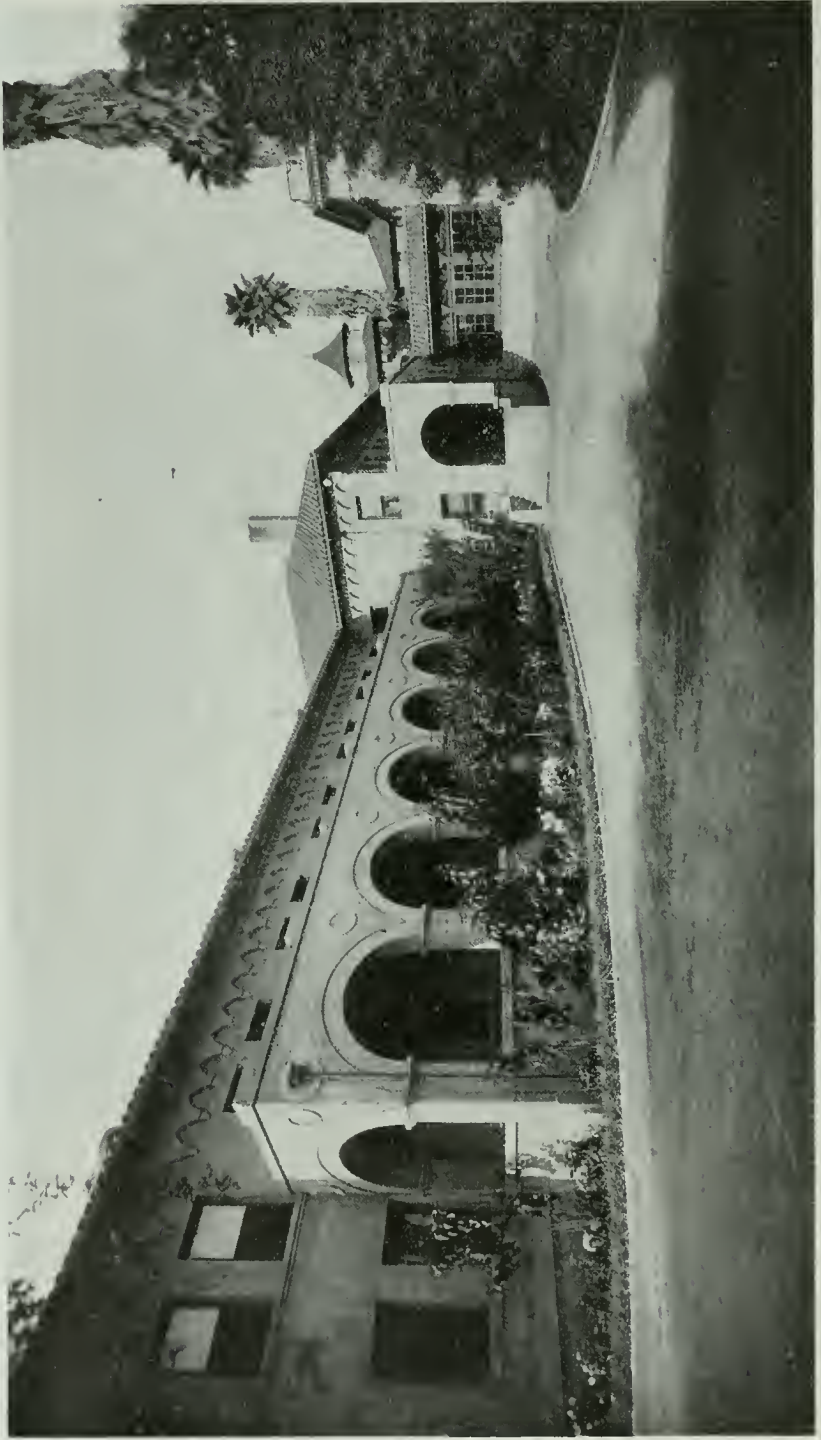

HOLLENBECK HOME FOR AGED PEOPLE, LOS ANGELES
MORGAN, WALLS & MORGAN, ARCHITECTS



HOLLENBECK HOME FOR AGED PEOPLE, LOS ANGELES,
MORGAN, WALLS & MORGAN, ARCHITECTS



VAN NUYS BUILDING, LOS ANGELES
MORGAN, WALLS & MORGAN, ARCHITECTS



VAN NUYS BUILDING, LOS ANGELES
MORGAN, WALLS & MORGAN, ARCHITECTS

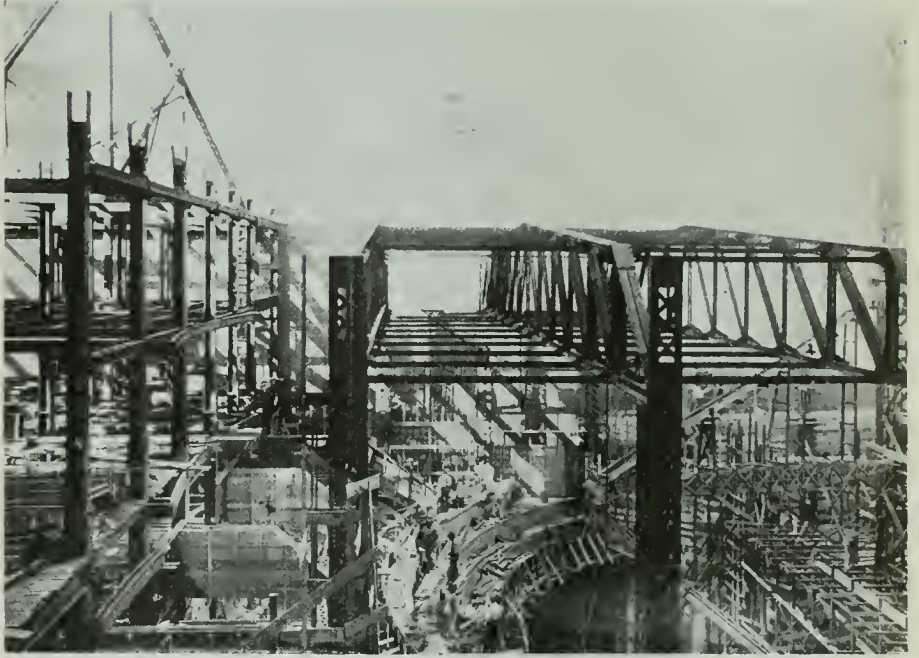

CONSTRUCTION PHOTOGRAPHS, MOROSCO THEATRE,
LOS ANGELES, MORGAN, WALLS & MORGAN, ARCHITECTS

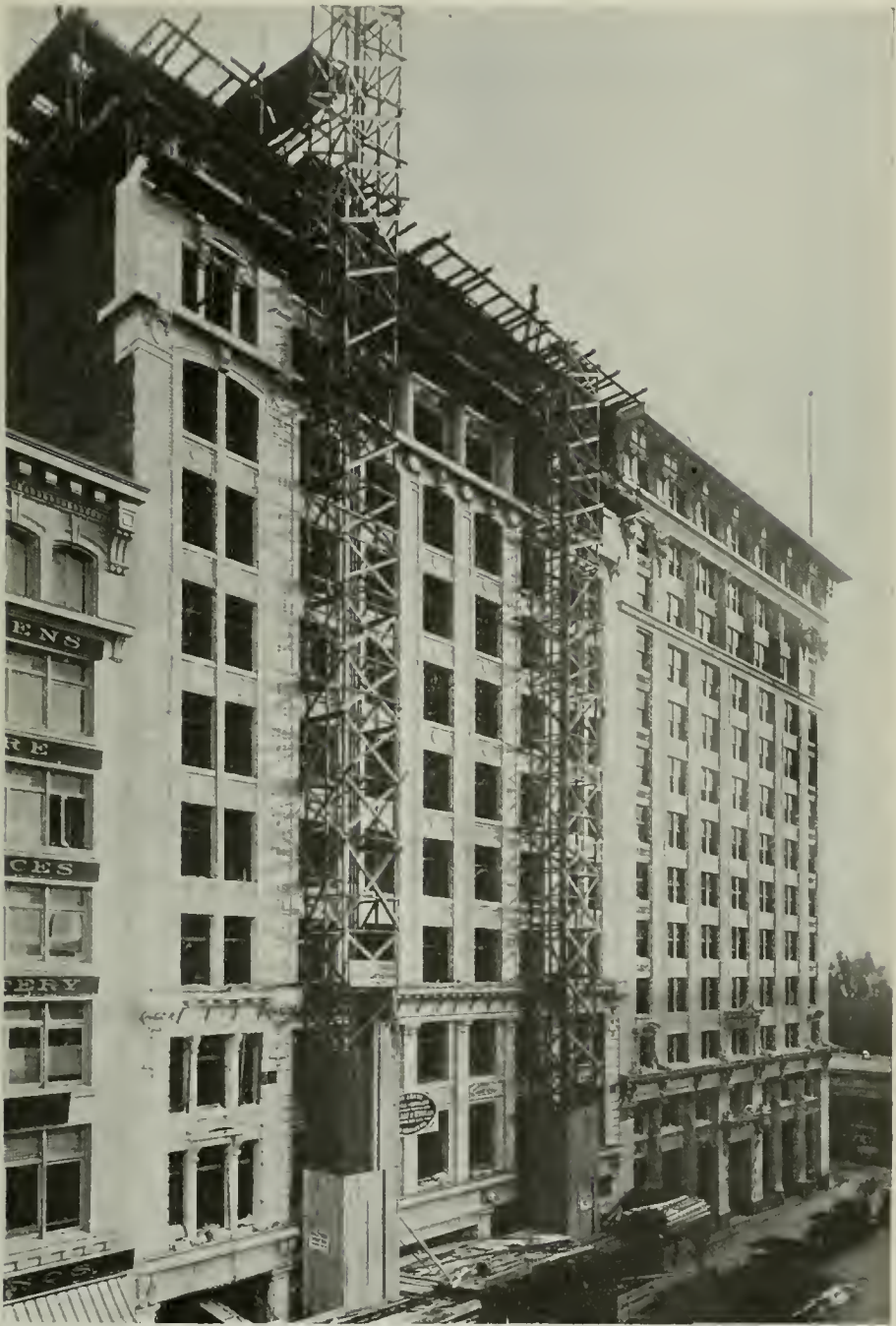

MOROSCO THEATRE, LOS ANGELES
MORGAN, WALLS & MORGAN, ARCHITECTS



LOS ANGELES STOCK EXCHANGE BUILDING, LOS ANGELES
MORGAN, WALLS & MORGAN, ARCHITECTS



HOUSE FOR DR. L. W. MANSUR, SHERMAN, CALIFORNIA
Morgan, Walls & Morgan, Architects



HALL, HOUSE FOR DR. L. W. MANSUR, SHERMAN, CALIFORNIA
Morgan, Walls & Morgan, Architects



PALACE GARAGE, SAN FRANCISCO
O'BRIEN BROS., ARCHITECTS



CHAPEL, CATACOMBS OF CYPRESS LAWN
B. J. S. CMILL, ARCHITECT



HOUSE FOR MR. C. H. WILLIAMS, FOREST HILL

S. HEIMAN, ARCHITECT



HOUSE FOR MR. J. W. HAMMOND, FOREST HILL

S. HEIMAN, ARCHITECT

The Planning of Theatres and Auditoriums*

By EDWIN H. FLAGG



New Orpheum Theatre, New Orleans, La.
G. Albert Lansburgh, Architect

IN speaking of Garnier, the designer of the National Opera House, Paris, Mr. Edwin O. Sachs, noted London architect, says: "Garnier was not in sympathy with any of the prevailing theories of acoustics. He rather emphatically claimed he was not guided by scientific data on acoustics when he determined the principal lines.

"Now Charles Garnier succeeded in designing an auditorium in which one can hear well and in which the general properties are highly satisfactory, and so his intuition may be taken as having been correct.

"But it is very rare that successful results are obtained by mere intuition, unless by such specialists as have, in addition, had a very considerable experience in the matter, and even some of these have been known to have made the worst of mistakes."†

In an editorial in the *American Architect*, under date of December 31, 1913, appears the following: "As the searchlight of investigation is directed upon each of the elements and properties of building construction, the more fully we realize that no one man can be a specialist in every one of them.

"Rather the architect is coming more and more to be a director of other men's services in producing the design which he conceived as a whole.

"The director, as well as the small practitioner, who does his own work should have an accurate general knowledge of the methods employed by the experts."

The theatre designer should keep in mind topography of location, regulating levels of exits and their relation to the stage and auditorium so that they interfere the least with the practical operation of both stage and auditorium; he should also keep in mind the seating capacity desired and the locating of shops or offices in whatever additional space that is available; remembering not to sacrifice any seat space for stores, as more can be realized from seats than from stores.

Let us first consider the stage—the size and equipment. Marking off the stage usually calls for something in excess of thirty feet deep by sixty feet wide, in the clear, exclusive of dressing rooms, establishing the arch itself in the center of the auditorium side.

The proscenium arch should be about 24 ft. high by 36 ft. wide. Wider if possible by from 2 to 10 ft., but there is not so much reason for its being any higher, unless it be an especially large auditorium. As very few top galleries are being built now, there cannot be that argument for the higher arch, and in any event as front draperies, i. e. valance, grand drapery and

†Modern Opera Houses and Theatres, published in London in 1898.

*Second installment. Mr. Flagg's first article appeared in the October, 1920, *Architect and Engineer*.

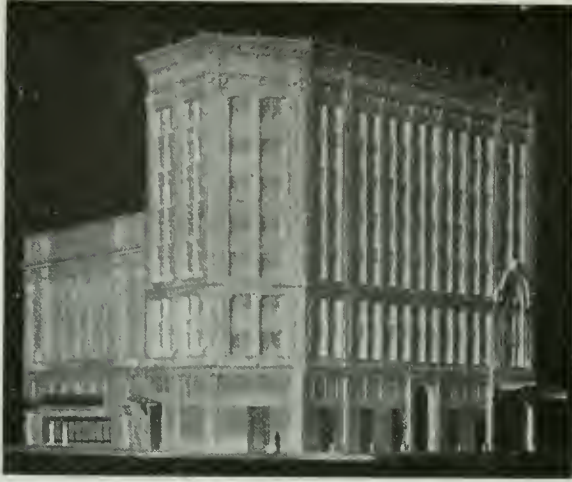

LOWE'S STATE THEATRE, SAN FRANCISCO
G. Albert Lansburgh, Architect



MERCY THEATRE
North Yakima, Wash.

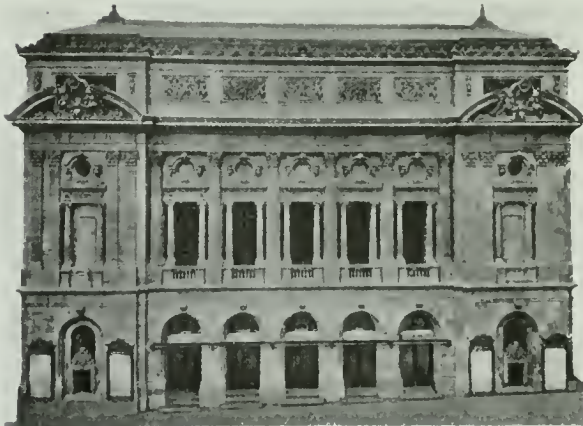

ORPHEUM THEATRE, KANSAS CITY, MO.
G. Albert Lansburgh, Architect

teaser, have to be sufficiently low to mask regulation scenery, there is no gain in increasing the height of the arch.

But as to width it is different. An arch should be as wide as possible, leaving not less than ten, and preferably sixteen feet in the clear, between the side of the arch and the side wall of the stage. The wider an arch the better it is for those seated on either side of the auditorium in the front. But it is of more vital importance to have off-stage working space at each side of the arch.

There are many examples of this mistake, but probably the worst, and one for which there was not the slightest excuse, is the stage of the San Francisco Polytechnic high school. Here the space was practically unlimited. The construction was the costliest. After trying to use it, the faculty of the school and the building department attaches of the city pronounced it impossible to use it as a stage until about five thousand dollars worth of partitions (lath and plaster) were removed. It was almost unbelievable that hundreds of square feet of concrete partitions had been for no reason in the world placed where they rendered the stage utterly useless, except as a rostrum.

The stages in the State Normal school in San Jose and the one in the Modesto High school have the same mistake, in fact in each of these, though they are pretentious, elaborately outfitted stages, equipped with scenery, border lights, etc., each and every mistake that it was possible to make and still leave any semblance to a stage was made.

Contrast these with the Grammar school stage in the little town of Los Banos, located about half way between and about fifty miles distant from each of the above cities.

Although this stage didn't cost a fraction of what each of the other stages cost, still it is more commodious and far more practical, answering admirably every requirement that can ever be put upon it.

I do not know who the architects were on any of these three buildings, so that I cannot be accused of partiality or prejudice. Only I equipped all three of them.

The width of the prosceniums of most of the theatres in the country which have proven satisfactory, it will be noted from the table of dimensions of existing theatres shown in another part of this article, is from 36 to 38 feet. But if sufficient off-stage space is available, additional width is advisable. Additional height is not essential but width is.

The laws of some cities notwithstanding, the footlights need not be over one foot from the curtain line, and they should extend in a straight line (not curved) from one side of the proscenium arch to the other, stopping one foot from the arch. The curtain line is where the fire curtain touches the stage.

Stage Directions

The side of the stage on which the switchboard is located, usually the right, looking from the stage toward the auditorium, is called the "prompt" side, derived from the fact that that was where the prompters stood. The extreme left side of the stage is called the "O. P.," or opposite prompt, side. The central part at right angles with the proscenium is called "center." And at right angles with the proscenium, half way toward the center from the right is the "right center"; the opposite side is called "left center."

Toward the back wall from any part of the stage is called "upstage," and towards the footlights is "downstage." Right and left is always designated by looking from the stage toward the auditorium. "Off-stage"



JUNIOR ORPHEUM, LOS ANGELES
G. A. Lansburgh, Architect

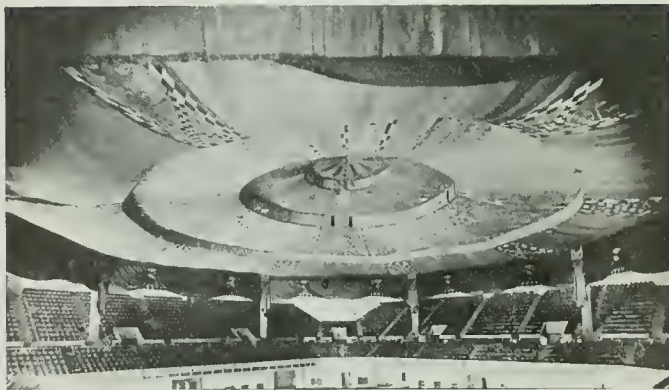

This immense canopy, dropped beneath the dome of San Francisco's Auditorium with a number of other changes and improvements, removed all echoes and reverberations. G. Albert Lansburgh, Architect.

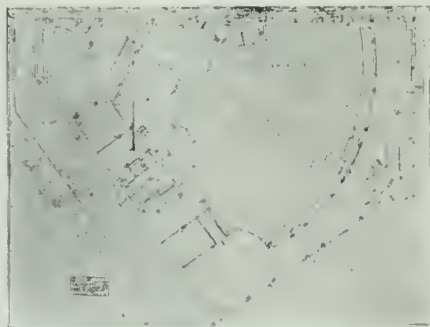

Perfect utilization of available space, new Lowe's State Theatre, San Francisco. G. Albert Lansburgh, Architect.

designates either to the right or to the left from the center of the stage. "On-stage" means toward the center from either side.

On the switchboard side, usually, and extending from the front to the back wall, is the "fly-gallery," from four to six feet or wider, built out from the side wall, about 24 ft. above the stage—or not higher than half the distance from the stage to gridiron—less five feet, or not closer than 19 ft. to the stage.

On the on-stage side, except in the Boller model, are the "pin-rails," in which the "belaying-pins" are inserted, and to which the lines operating the "drops" are "tied-off." There are two of these pin-rails, a "lower" and an "upper" one. Where fire laws will allow it, and elsewhere if possible, this rail should be of Oregon pine, six inches high and four inches wide, the lower rail, two feet from the floor to the under side. The face of it back ten inches from the face of the fly-gallery. The upper-rail sets with its on-stage side flush with the fly-gallery, 3 feet 6 inches from its under side to the floor of the fly-gallery.

Both of these rails should be sunk into both the front and back wall a couple of inches, and supported and bolted down to the fly-gallery about every seven feet. As the strain is all upwards, a two by four, edgewise, will hold them up, placed beside each $\frac{3}{4}$ -in. iron rod that, carried up through the fly-floor, passes through the center of the rail, made fast with a nut and a large brick washer to hold it down. The supports of the floor of this fly-gallery must be strong enough to hold down a strain of several tons pulling up, but distributed over the length of these rails. The rails should be bored with one and one-eighth-inch holes vertically on eight-inch centers to receive the belaying pins. The holes should be staggered where there are two rails.

These pins are furnished in oak or hickory of a standard pattern used exclusively throughout the United States and should be supplied by any distributor of J. R. Clancy of Syracuse, N. Y. It is preferable to use not only Clancy's belaying pins but his entire line of stage hardware, as it is not only the most practical and economical, but so universally used that most users of stage hardware for two generations know of no other source of supply.

If local fire laws absolutely compel it, the pin-rails must be of five-inch iron pipe, and should have a wooden core, so that the pins will not spin out when drops are lowered.

The old style O. P. fly-gallery is almost extinct, as drops are always worked from one side of the stage only. If desired as a tie to brace the back wall to the proscenium, or to store junk, or use as a light gallery, to set spot and flood lights to illuminate certain parts of the stage, it is permissible to then have an O. P. fly-gallery.

No beams can extend from the front to the back wall, with the exception of these galleries, as they would interfere with the hanging and operation of drops, borders or cycloramas. The back wall of the stage must be sufficiently strong to withstand wind pressure and all other emergencies, without the employment of any other braces or tie beams, excepting the gridiron or rigging loft, and the fly-galleries.

The "gridiron" is the open lattice work, six feet below the roof, and twice the height of the proscenium arch plus 5 ft., above the stage. It commonly extends over the entire stage and is divided by four open slots, extending through it from the front to the back wall. Three of these slots are for the lines to which the drops are hung to pass through, up and over six-inch iron sheaves, over to the side of the stage over the pin-rail, through a triple, tandem, headblock and down to the pin-rail to be tied off,

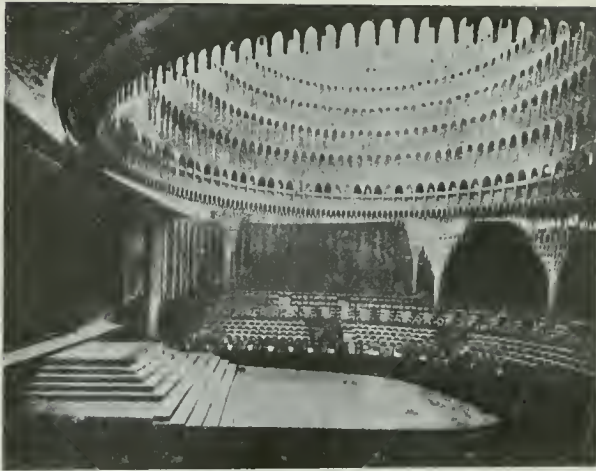

Max Reinhardt's new 3000 seat house in Berlin, the remodeled Schumann Circus, showing the old Greek orchestra, and 90 ft. stage, all parts of which may be raised and lowered.

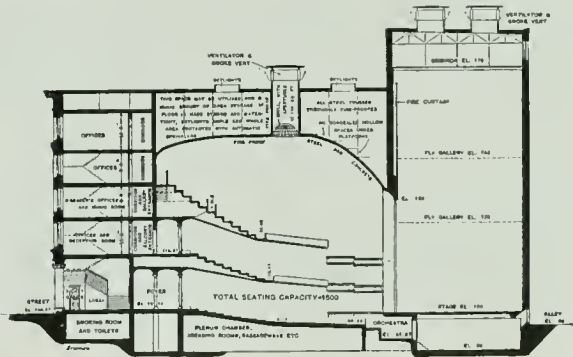

Three plans by Freeman, showing section, ground floor and balcony arrangement of fire exits, open court, and passage under stage to alley, ventilators over stage, offices, etc.

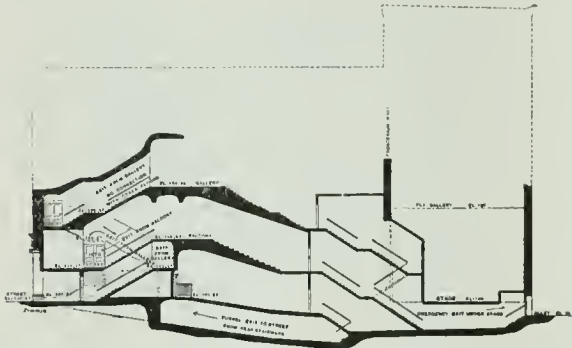

Section (Freeman) showing exit from balcony to alley without losing valuable stage space, and from sides of auditorium through basement tunnel to street.

or down to a counterweight (sand bag or cast iron) which in turn is operated with an endless line extending to the stage, threaded through a floor sheave, and back up to the gridiron where it passes over another sheave, and back down to and is, tied off at the top of the counterweight.

These slots and the sheaves that rest in each one, and the lines that run through each one, are named, and universally are called by their position from the pin-rail. Experience has proven that the regulation drop can be more satisfactorily hung and trimmed square with the stage when lowered, when it is suspended from three lines. Naturally the center is the first place to tie one line, and about three feet from each end balances the drop the best for each of the other two.

The center, line, sheave and slot are called "center." The line running up, over and down nearest to the pin-rail is naturally shorter than the center, so it is called the "short," line, sheave and slot; and the one farthest away is the longest, so it is called the "long" line, sheave and slot. These slots should each be about eight inches wide. The headblock slot should be about sixteen inches wide to accommodate the three sheaves, tandem, which, with their construction shell, requires an open slot, either, to be exact, $13\frac{3}{4}$ " or $18\frac{1}{2}$ ", depending on the choice of block desired. These, as well as all other dimensions on stage hardware fittings, should be settled by the architect, after consulting an expert, before plans are made; by the actual sizes of the patterns that are determined, to be the best for the particular job, and the patterns decided upon are marked in, and a copy of a Clancy catalogue, retained by the architect, for future reference, as the measurements apply to other parts of the construction.

As the usual drop is thirty-six feet wide, three feet from each end would place the lines, fifteen feet from center each way. This gives the rule for the long and short line slots being each fifteen feet on center right and left from the center slot.

The best cordage from which these drops can be suspended has been found to be a pure manila plymouth soft laid rope for theatrical purposes. It is more pliable, soft to the hands, free of kinks and twists, and while it costs slightly more per pound, it runs more feet to the pound and is stronger than any other kind of rope of the same diameter.

The minimum tensile strength of this rope is as follows:

$\frac{1}{2}$ "	2450 lbs.	Ft. per lb.	13' 4"
$\frac{9}{16}$ "	3150 lbs.	Ft. per lb.	9' 7"
$\frac{5}{8}$ "	4000 lbs.	Ft. per lb.	7' 6"

New Zealand or British manila is 82 per cent the strength of the above and Sisal is 67 per cent. Rope runs about 1200 feet to the coil.

Drops are usually painted on heavy, coarse cotton or on coarse, open linen cloth, which is sandwiched at the top and bottom between two $\frac{7}{8}$ " by $3\frac{1}{2}$ " sugar or white pine battens spliced to the desired length, with the joints properly scarfed. A scarfed-joint is one that is lapped with a long angle end, securely glued, tacked and nailed, forming a continuous batten.

Road show drops are rolled up and transported on these battens, having a 30" width of duck tarpaulin tacked on the back of the upper batten, into which the whole drop and both battens are rolled for protection.

In the Boller (Carl and Robt. Boller, Architects, Kansas City, Mo.) model of fly-gallery the headblock slot is against the side wall, and the fly-gallery itself is built out from the wall about sixteen inches, allowing the counter weights and lines to either extend down to and be operated from a pin-rail on the stage, or if desired to be tied off at either of two pin-rails, one at each side of the fly-gallery, each 3 feet from fly floor to under side of rail.

(To be Continued.)

Losses of Housing Due to Fire Waste

By WHARTON CLAY, Architectural Engineer

IN 1918 there were approximately 20,000 houses built. During the same year there was approximately \$63,000,000 of loss in residential occupancies paid by fire insurance companies (this is, of course, less than the total losses due to non-insurance of many houses). These figures are furnished by the National Board of Fire Underwriters. Sixty-three million dollars would construct about sixteen thousand \$4,000 houses, while only twenty thousand houses were built. In other words, the fire loss in residential construction was almost as great as the value of the housing constructed that year.

Fifty-three per cent of all the fires reported in Wisconsin last year were in places of residence, there being 1395 residence fires and 112 flat building fires. To quote Mr. J. E. Florin, Superintendent of Fire Prevention of Wisconsin:

"Why burn 125 houses a month when we have far from enough?"

In 1917, the loss was \$66,000,000. It is understood, of course, that this does not indicate that 16,000 houses were burned to the ground, but that the same amount of labor, transportation and material which were lost could have been converted into 16,000 houses, a very material yearly contribution to our housing shortage.

Ninety-six per cent of all fires originate within the house on which the loss is paid. The balance of 4 per cent only is due to conflagration, but the great majority of fires originate and are stopped by the fire department within the individual house.

Approximately 99 per cent of the housing construction normally has wood stud partitions and wood joists—a very economical construction but usually not protected to a sufficient degree of security against fire. Data as to the spread of fires in homes may be obtained from the statistics credited to the National Board of Fire Underwriters printed in "Fire Protection Magazine," Cincinnati, issued June 4, 1920, and has been found to have been compiled by the chief of the New York Fire Department:

Manner of Extension of Fires in New York—	Percentage of Total
Lofts	1.3
Doors	4.0
Dumbwaiter Shaft	13.8
Flooring	14.2
Halls and Stairways	8.5
Lath and Plaster Partitions.....	28.6
Light and Air Shafts.....	5.8
Pipe Recesses	11.7
Windows	12.1

The ratio of fire losses to value of new buildings (all classes) for the last ten years in 171 cities in the United States was .265. In other words, over 25 per cent of the value of the new buildings, of all classes, was lost each year due to fire. This information, published in "Concrete in Architecture and Engineering," and reprinted in "Fire Protection," Cincinnati, June, 1920, based on figures on building values compiled by the "American Contractor," Chicago, as compared to fire losses compiled by Bradstreet's report of January 17, 1920.

As a vast majority of houses contain wood construction, the most logical and most effective recommendations are those which will deal with the protection of wood construction against fire.

The points most vulnerable to attack by fire are:

Bearing partitions and stud exterior walls, including the usual inefficient fire stop at juncture of floors and partitions;

Ceilings under inhabited floors, especially over heating plants and coal bins;

At chimney breasts, around flues and back of kitchen ranges;

Stair wells and under stairs.

While the instances of conflagration develop a very spectacular object lesson of housing loss, it must be always remembered that the every-day fire which occurs here, there and everywhere every few minutes throughout the United States, originating within the house and never getting beyond it, produces the greater loss.

The latest estimates on loss of life due to fires made at a conference between the National Board of Fire Underwriters and the Fire Marshals' Association places the loss at 23,000 persons per year. Information was obtained from Mr. Brearley, National Board of Fire Underwriters, New York. The economic value of 23,000 lives is considerable. If each one of these lives was reckoned as of an economic value of \$5,000, this would amount to a loss of \$125,000,000.

All of the above information has been brought to light through an investigation for the metallic lathing manufacturers, and in my opinion, transcends their commercial interest. Because of its relation to housing conditions, it becomes a matter of nationally important public concern.

It is evident that losses due to fire in residence construction are a constant drain upon the housing resources of this nation. There are economical materials available which can be employed in even the most modest houses to protect the structural wood members for about an hour. Studies by such agencies as the Underwriters' Laboratories and Bureau of Standards, should be given full publicity and more stringent restrictions by building ordinances or governmental authority should be promulgated to conserve the terrific life and property loss which is occurring in this country every day and has no parallel in any country in the world.

* * *

Waterproofing Blue Prints and Drawings

A simple method of waterproofing drawings, blue prints, etc., described by Mr. F. A. McLean, in the *American Machinist*, consists in saturating the prints with "parawax," a melted parafine wax such as is used for sealing fruit jars. Mr. McLean states that if the prints are placed directly into a pan filled with this molten wax they will soak up too much of it and will always feel more or less greasy to the touch. The most convenient way, therefore, is to soak a number of pieces of absorbent cotton cloth a foot or more square in the wax. When these pieces of cloth are cool lay as many as are required (depending on the size of the blueprint) on a table or other smooth surface, place the print on top of these and then on top of the print lay more of the cloths until it is entirely covered. After this is done it is only necessary to run a hot iron over them for a few moments. The print will immediately absorb the parafine until the surface becomes saturated. If the table on which the work is carried out has a highly finished surface a layer or two of heavy wrapping paper should be placed between the cloths and the table. Should one of the family irons be used in the process it would be a good plan to interpose a piece of wrapping paper between the iron and the cloth, as it will prevent the iron from being fouled with the wax.

Collapse of Long Beach Church Dome

FALLING of the concrete dome over the auditorium of the new edifice of the First Christian church in Long Beach, December 16, caused damage to the structure estimated at about \$100,000. The accident occurred at noon, just after the workmen had quit for lunch and, fortunately, there were no fatalities and slight injuries only were sustained by a few men. The dome had been completed about four months and the forms had been removed for some time. The ceiling in the auditorium was plastered and the art stone on the exterior was being set.

Both the architectural and engineering plans for the structure had been carefully prepared and checked by three different engineers, it is said, and the structural work had passed rigid inspection, the concrete in the dome being described as fully up to specifications. An investigation is now under way with a view to determining, if possible, the cause of the accident.

The concrete dome, the top of which was 76 ft. above ground, was supported by four reinforced concrete columns and a series of steel trusses. The columns carried four 10-panel steel Howe trusses, each about 62 ft. in length, 14 ft. deep in the center and 9 ft., 6 in. deep at the ends. In the square formed by these trusses were four diagonal 5-panel steel trusses, each 41 ft. long, the ends of which were riveted to and supported by the main trusses. The third series of steel trusses, of which there were also four, each 25 ft. long, with 3 panels, cut the angles in the second square and formed an octagonal base for the circular dome, which was 48 ft. in diameter at the top.

At the base of the dome was a vertical solid wall of 8-in. concrete from which sprung a ribbed segment with radius of 37 ft., 4 in. There were eight ribs, each 12x12 in., carrying a concrete shell 3 in. thick, reinforced with rods and steel fabric. The weight of the dome, estimated at about 200 tons, was carried directly on the series of steel trusses supported by the concrete piers. When the dome fell the steel trusses sheared away from the reinforced concrete columns which stood intact, the plates at the tops remaining in place.

The following statement was submitted by Mr. Robert H. Orr, the architect, to the official board of the First Christian church:

An investigation is now being conducted by the State Accident Commission and the City of Long Beach of the collapse of the dome of your church building while under construction.

Owing to the many rumors and articles appearing in the daily press, it seems a statement should be made of the facts as far as known in order to correct erroneous impressions.

The plans were carefully made and checked. All the reinforced concrete designs passed through the hands of two competent engineers. The steel work was engineered by my engineer, checked by two others of repute whose signed reports have been on file in my office for more than a year. In addition to this the fabricating company rechecked the steel trusses before erecting the same.

The work was being carried out in strict compliance with the plans and specifications. My files do not show any but minor changes which did not affect construction or stability, and where changes did occur they were authorized by written order.

The contractor and superintendent took every precaution to see that the workmanship was of the best. The reinforced concrete is an excellent job, which statement is borne out by the fact that the gallery, balcony and main floor withstood the terrific impact of tons of falling materials.

One thing appears unquestionably evident: the failure was not due to reinforced concrete, as the four columns supporting the dome are still standing with the anchor bolts in place. Whatever else may be the cause will be determined by the investigating committees. Every assistance will be given them and a full and thorough investigation into the design, quality of materials and workmanship will be made and in due time official reports rendered and the cause of the accident fixed. At the present time the real cause is unknown.

It is most fortunate that no lives were lost. The financial loss is great, and coupled with the magnitude of the undertaking in the first place it seems an insurmountable task. The whole Brotherhood will be back of the Long Beach church and the completion, though delayed, can be accomplished.

The building can be entirely restored, without weakness in any place, and made absolutely safe. Let the original designs be carried out, making such changes in material and loads as shall now be necessary for structural stability.

Aided by your fortitude, Mr. Sherer, the contractor, Mr. Bird, the faithful superintendent, and I will, as before, give due vigilance and attention to restoring the damage and completing the task.

* * *

Architects Have a "Colony"

MINNEAPOLIS architects now boast of a "colony" of their own. A spacious building of Florentine design, located at Second avenue S. and Twelfth street, was thrown open to the public the first of last month.

"The exterior follows the Florentine style because it lends itself peculiarly well to varied window arrangements," Mr. Edwin H. Hewitt, architect, stated. "It is built of Indiana Bedford stone, has a frontage of 65 feet on Twelfth street and 110 feet on Second avenue, is four stories high, and cost \$150,000. The elevator well terminates in a tower in upper story, and above the machinery, is an artists' studio. Even the chimney carries out the design."

One of the unusual phases, according to the Minneapolis Daily Journal, is that while each firm will maintain its individual practice, many things will be used in common, such as the library, sample rooms, stenographers' room, blueprinting and specification printing.

The third and fourth stories are especially designed for offices, library, sample room, clients' room, consultation rooms, blueprinting room, contractors' consultation and reference room, stenographers' room, a fireproof vault for permanent records and valuable plans, and large drafting rooms that are subdivided by glass partitions, making them private for each firm, yet easily accessible to others, when consultation or suggestions are desired.

These two floors will house a group of professional men. A special addition on the first floor, and a large part of the basement, will be occupied by professional clubs, such as the Attic club, the Minnesota chapter of the American Institute of Architects, the Post and Lintel club and the Skylight club.

One of the rooms in the basement will be for the exclusive use of draftsmen who desire to study at night. A professor from the University of Minnesota will be available as instructor in design, and the studies will be in the nature of university extension work.

At one side of the building, away from Twelfth street, is a large lot that is to be terraced and developed into gardens in the spring. A colonnaded veranda opens on this space from the first floor.

The Flat Fee as a Measure of Equity

By JOHN LAWRENCE MAURAN

ABOUT ten years ago one of our most loyal and important clients came to us with an alteration and remodeling problem involving a considerable expenditure compared to the result he was seeking. He was, as we well knew, a timid man in matters wherein architects feel they are on their home grounds, although bold enough in the financial and real estate field. The exigencies of time and the character of reconstruction led us, as a condition to fulfilling his wishes, to insist on the selection of a certain contractor on a cost plus basis, and in spite of the fact that in those good days now gone by the "cost plus" had a definite limit of liability of about two hundred thousand dollars, our client showed his timidity by hesitating over the indefinite amount of our fee of ten per cent. Although we could hardly fathom the causes of hesitancy, the inspiration of the moment led us to suggest that we would do the work—whatever it might cost—for a flat fee of twenty thousand dollars. With unmistakable relief he seized upon the suggestion and everyone was happy even upon the day of completion a week ahead of time and with a saving of over seventeen thousand dollars. There is a psychology in it, for in spite of paying us some seventeen hundred dollars more than ten per cent, he had found security against the bugbear of increased costs involving increased architects' fees.

Now every architect worthy of the name would hotly repudiate the implied suggestion of bad faith, but we must remember that often the client's mind visualizes added fees with any suggested betterment, no matter how high his confidence in the disinterested character of the suggestion.

From the deep impression left on us of the satisfaction of the owner we profited a little later on when he retained us as architects for the first reinforced concrete building of any importance in St. Louis. It was an eight story wholesale building covering an entire city block and at an early stage in the negotiations, we perceived symptoms which led us to repeat our offer of a flat all-inclusive fee.

Our attitude through both these experiences was a more or less passive acceptance of the state of mind of a client, but quite recently we caught again the same note in the comments of clients during preliminary conferences, sounding a vague alarm as to skyrocketing of the fee in case of a pyrotechnic display in building costs.

This turned our thoughts to the two previous experiences, and changed our attitude from a passive one to an active advocacy of the fixed and all-inclusive fee, and late in 1919, when the material market had all the symptoms of an ascending escalator, we expressed our desire to fix in advance the exact obligation of the client for full architectural services, including the fixed fees, which we in turn agreed to pay the engineers engaged by us on work in their various branches.

Of course, the percentage system applied to the estimated cost furnished the basis for determining the fee named, but the fact that it was fixed gave our clients every assurance that their interests were paramount, and hence while we were bending every endeavor to protect them against spectacular advances, there could be no possible ground for even the unformulated suspicion that we, too, were profiteering at their expense through the unpreventable increases in cost over the already high level of the moment.

While there was a certain amount of surprise expressed, there were unmistakable signs of appreciation of what commended itself to them as to

us, as a business-like co-operation insuring justice to all concerned, for the surprise centered about an unsuspected flexibility of the architect's mind in his methods of calculating his remuneration.

It may prove of interest to record the rather unusual method we adopted in the handling of these commissions under very trying conditions. First of all we urged the immediate selection of a contractor of proved ability in the particular type of work, of absolute integrity and whose conditions of other work in progress at the moment justified such a step.

We further assured our clients that they could engage such a contractor to perform the work at cost plus a fixed fee. We also pointed out that in the purchase of material long in advance of the preparation of plans and specifications, that the logical method of handling such an undertaking was through the functioning of a "Committee of the Whole," consisting of owner, architect, contractor, the owner's operating engineer or manager and the architect's engineers (structural, mechanical, electrical, etc.) sitting together with one common purpose to discuss, decide and act on every matter whether to purchase or the choice of methods and materials.

Another phase of "all-inclusiveness" as pertaining to the architect's fee (however arrived at) is the oft-time unspoken objection in the client's mind to the little understood separate payment of the clerk of the works, as well as the engineers. One of our clients voiced this feeling recently when he blurted out "we paid for your superintendents on the last job." From our recent experiences I can vouch for the fact that while we have been fully reimbursed, our clients' satisfaction in the "all-inclusive fixed fee" has fully justified its adoption.

In looking back over the operation of the "Committee system," the application of the "fixed fee" to sub-contractors as well as the general contractors, and especially to our own "all-inclusive fixed fee" for architectural and engineering services, there were many occasions which spring to mind when we were thankful, indeed, not only because the disinterested character of our services excluded them from the often trying discussions over jumping prices, but more particularly because of the comfortable feeling that while we were being adequately paid for the service rendered, we were not profiting by the misfortunes of our clients, and so we feel that we can conscientiously commend to the profession and to our future clients, "the flat fee as a measure of equity."—Journal of American Institute of Architects.

* * *

An Electric City

Mr. Franklin K. Lane, in *The National Geographic Magazine*, writes of the change that has come over Idaho: "Seven years ago I visited the Minidoka project in that state and found the people discontented. Today, they are, I suppose, among the happiest farmers and the most contented people in our country. Here I saw a town where there never has been a fire lighted and some houses without fireplaces and without chimneys. No fires were necessary because at the dam above the town the water had been stored to irrigate the land and at the dam electric power was generated for use as heat, light and for cooking. The women churned with electricity. I suppose they had a sort of paddling machine for the naughty children that they ran by electricity. It was an electric city. Idaho is a rich state and is growing rapidly."

Notes on Recent Developments in Concrete

By LIEUT. COL. H. C. BOYDEN.*

IT is possible that some of the points to be brought out in this paper are more or less familiar to some of those present, through the reading of publications on the subject and the discussion of them in the technical press. The art of making concrete is an old one, but it is only in recent years that serious large scale investigations of its structure and the real effect of various combinations of the ingredients, have been undertaken.

In 1914 the structural materials research laboratory was established at Lewis Institute, Chicago, with Prof. Duff A. Abrams at its head. The establishment of this laboratory was made possible through the co-operation of the Portland Cement Association and the Lewis Institute. This laboratory is a striking example of co-operation between an engineering college and a manufacturing industry of international scope.

There are only two ideas governing the policy of this laboratory; the first is, that the real facts regarding concrete and its ingredients shall be found out, with a liberal policy regarding the time required and the expense involved; the second is, that whatever the conclusions may be, they shall be given to the engineering profession for the improvement of the art of making concrete.

These investigations are still being carried on, but many points of vital importance have been established. As an example, the established data warrants the use of considerably higher unit stresses than those in common use today, with a consequent reduction in section.

Conclusions have also been arrived at that will enable us to obtain excellent results with aggregate heretofore condemned and to greatly increase the ability of concrete to resist wear.

These conclusions and many others, are all based on tests running into the thousands and covering long periods of time. Incidentally I might mention that the laboratory is equipped for and is making close to 50,000 tests a year, so that there is no lack of facilities for carrying out investigations in the most thorough manner.

General—The study of concrete may be conveniently divided into three phases:

1. The study of the characteristics of the ingredients.
2. The study of the effect of making various combinations of these ingredients.
3. The study of the effect of the various manipulations of the ingredients in making and curing the concrete.

I shall only attempt in this paper to touch on those investigations that have brought out essential changes in our previous ideas of the subject or have confirmed those ideas beyond a doubt.

It has been the custom to speak of concrete as having three ingredients, cement, fine aggregate and coarse aggregate. The laboratory studies have shown the desirability of classifying the ingredients as cement, aggregate and water, or if it is still desired to maintain the purely arbitrary division of the aggregate into fine and coarse, to add the fourth ingredient, water.

Although cement is one of the most important ingredients of concrete, it requires probably the least discussion, as all the standard brands of Portland cement on the market today conform to generally accepted speci-

*Member of American Society of Civil Engineers. Paper read at a meeting in Los Angeles, under the auspices of the Joint Committee of Technical Societies.

cations and the laboratory investigations have brought out no essential changes in these specifications.

As stated above, the aggregate has always been divided into two parts, sand and crushed stone or pebbles. The line of division, purely an arbitrary one, has been the quarter-inch screen, the portion passing through this screen has been classified as fine aggregate or sand, and that portion retained on the screen being called the coarse aggregate. There is no particular advantage gained by this division but it would be much better to consider the aggregate as a whole, with a proper gradation of the various sizes from the largest to the smallest. It is not intended by this, however, to recommend the use of bank run or crusher run aggregate, as under no conditions should they be used without separating the sizes and recombining in the proper proportions.

However, until such time as this method of considering the aggregate shall have become of general practice we will consider it as divided into two parts by the $\frac{1}{4}$ -inch or No. 4 screen, and will so discuss it.

Fine Aggregate—We have been accustomed to specify that the fine aggregate shall be clean, sharp and not too fine. It would be better to use the word hard rather than sharp, since rounded particles find their way into place more readily than do sharp ones and require less water to produce a workable mixture. It is this lowering of the relative quantity of water used that causes the greater compressive strength found in concrete made with smooth rounded sands.

The laboratory studies have brought out two important facts regarding sands. One of these is the great importance of being sure that the material is clean, not only in appearance but in fact. Very often sand which appears to the eye to be clean, contains enough humus or vegetable matter to reduce the strength of the concrete very considerably.

As an illustration, a clean sand gave a compressive strength at 28 days of 1900 pounds. This same sand with one-tenth of one per cent of tannic acid added, gave a strength of only 1400 pounds; in other words, one thousandth part of organic impurities in terms of the weight of the sand reduced the strength of the concrete over 25 per cent. In the investigation of the effect of organic impurities many natural sands were used, but as it was not feasible to secure sands containing a wide variation of organic impurities, tannic acid was used as a substitute for the purpose of making further tests. It was felt that the effect produced by such a material would probably be a measure of the effect produced by other organic impurities which might be present in natural sand.

How can we detect these organic impurities if we cannot see them by ordinary inspection? By using the colorimetric test for organic impurities devised at the laboratory. This test consists of digesting a representative sample of the sand in a dilute solution of sodium hydroxide (caustic soda—Na OH) and observing the resulting color of the liquid.

All that is needed is a 12-oz. prescription bottle and a little 3 per cent solution of caustic soda or sodium hydroxide, both obtainable at any drug store.

Put in about 4 1-2 ounces of the sand to be tested, fill up to the 7-ounce mark, after shaking, with the solution of caustic soda, let it stand for 24 hours and observe the liquid on top. If this liquid is clear or light straw colored use the sand, if it runs into the brown color and especially dark brown, reject the sand or wash it thoroughly before using.

The second fact is that fine sand behaves exactly the same as coarse sand with one exception. In order to produce a plastic workable mixture with fine sand it is necessary to use more water than with a coarse sand. It is the excess of water that reduces the strength of the concrete. In other words, if we could mix our concrete with the same quantity of water regardless of the grading of the sand, and obtain a plastic mix in both cases, we would secure the same strength in the concrete.

Coarse Aggregate—When studying the characteristics of the coarse aggregate one conclusion has been brought out very sharply; namely, that the hardness of the aggregate is a secondary consideration as compared with other factors in developing high crushing strength in concrete, and of less importance than ordinarily supposed in developing wearing qualities. This was very clearly shown in comparative tests made of burnt shale for use in building concrete ships. Samples made with this aggregate compared very favorably with those made up using a much harder aggregate. A stone must be very friable indeed if it is not strong enough, when properly combined in concrete, to more than maintain the load likely to be carried by the concrete.

The reason for high compressive results given where a light, soft aggregate is used is because the water content is reduced, owing to the porosity of the aggregate and not due to a higher compressive strength in the aggregate. Again we find the relative quantity of the mixing water to be the governing factor.

For road surfaces, however, we need another quality in our concrete, namely, wearing or abrasive quality, and to obtain this the stone must not be too soft. It is not advisable to use a stone with a French coefficient of less than 7, although pavements have given excellent results made with stone having a coefficient as low as 6.

It is not intended in calling attention to the above results to advise throwing down the bars and allowing the use of any and all stones, irrespective of their hardness or wearing qualities. It is desired, however, to show that many of the safeguards we have been putting into specifications in past years are not safeguards at all, but that the effect of following them may be entirely lost through neglect to observe other factors of more vital importance. It is always advisable to use the best materials obtainable but there have been many cases, where the local and easily obtained material has been rejected, when it could have been used with excellent results, by following proper principles in proportioning and protecting the concrete.

Oftentimes better results would have been obtained than resulted from the use of imported materials and then neglecting the really important factors in making good concrete.

Water—The remaining ingredient of concrete, water, is in reality of equal importance with the cement in obtaining good concrete, and yet it is often the most carelessly used and most loosely specified of all the ingredients, generally not mentioned in specifications and frequently not even reported in test data.

The laboratory is now conducting tests of waters sent in from all parts of the country, but definite conclusions have not as yet been developed. It is safe to say, however, that waters which are strongly alkaline should not be used and, owing to the possibility that marsh waters may contain sufficient humus matter to seriously affect the strength of concrete, they should be looked upon with suspicion until tested in concrete and found satisfactory.

With regards to the temperature of the mixing water, tests have been made, using water ranging in temperature from 32 degrees to 212 degrees F. It was found that the temperature of the mixing water had very little to do with the strength of the concrete at seven days to one year. The use of hot water is, however, a valuable aid in removing frost from the aggregate in cold weather owing to its high specific heat and may be used without danger of harming the concrete.

It is, on studying the second phase of concrete making, that there has been brought out at the laboratory new and, in some ways, radical changes in the past and present practices of proportioning.

These investigations have brought out the following facts: That the present method of designing concrete mixtures by using arbitrary volumes is wrong; that there is one single proportion which will give the best results with a certain mixture of given fine and coarse aggregates; adding to or reducing the amount of cement is of value only as it affects the relative quantity of water required to make a workable plastic mixture and, above all, that the water-ratio is the most important element of a concrete mix. The water-ratio is the ratio of volume of water to the volume of cement in the batch. If 1 cu. ft. of water (7.5 gals.) is used for each sack of cement, the water-ratio is 1.00.

The use of more cement in a batch does not produce any beneficial effect except from the fact that a plastic, workable mix can be produced with a lower water-ratio. The reason that a rich mixture gives a higher strength than a leaner one is not that more cement is used, but because the concrete can be mixed with a water-ratio which is relatively lower for the richer mixture than for the lean one. If advantage is not taken of this possibility of reducing the water-ratio the additional cement in the richer mixture is wasted.

Fineness Modulus—In studying the results of the tests of many samples of various combinations of aggregates it was evident that there must be some relation between the size and grading of the aggregates and the strength of the concrete. In trying to find this relation Professor Abrams struck upon what is called the "fineness modulus" of aggregates and when this was compared with the strengths of the concretes a direct relation was found to exist.

The fineness modulus is a very simple function of the sieve analysis of the aggregate used for any particular concrete. The sand and stone are analyzed with a set of Tyler standard sieves, each one of which has a clear opening double the width of the next smaller. The following sizes are used: 100, 48, 28, 14, 8, 4, $\frac{3}{8}$ ", $\frac{3}{4}$ " and $1\frac{1}{2}$ ". The percentages (by volume or by weight) of the total aggregate coarser than each sieve are added together, the sum of these percentages is divided by 100 and the result is the fineness modulus. The fineness modulus of any combination of the fine and coarse aggregates may be found in exactly the same manner.

Many different gradings may possess the same fineness modulus; in other words, many different gradings may be used and still secure the same compressive strength in the concrete.

It is not possible to go into details of the use of this factor for the design of concrete mixtures in a talk of this length but they have been published in the Engineering News-Record on April 17, 1919, and a careful study will enable one to use it successfully.

It is not claimed that this method of designing concrete mixtures is the only one that will give the desired results, but the laboratory tests prove

beyond a doubt that there is a direct relation between the compressive strength of concrete and the factor called the "fineness modulus." This is due to the fact that the fineness modulus reflects the changes in water ratio necessary to produce a given plastic condition in concrete. Accepting this as a fact, it is possible to design a concrete mixture that will give a certain desired compressive strength from almost any combination of aggregates.

Abrams' Tables of Proportions—In order to make this more easily available to the engineers of the country, Prof. Abrams has worked out a table containing 135 proportions with different combinations of aggregates, which if used with materials acceptable as to quality, will give a concrete with a comprehensive strength at 28 days of approximately 3000 lbs. per sq. in. All the tests for the determination of the factors in this table were made of a concrete of a workable plasticity, formed into cylinders 6x12 ins. and tested at the end of 28 days.

In conformity with present practice the aggregate is divided in the table into fine and coarse, and covers combinations of five classes of fine aggregates with twenty-seven classes of coarse aggregates.

In order to determine what class a known aggregate shall be placed in, the following rules should be followed: if a fine aggregate, at least 15 per cent of the total shall be retained on the next smaller sized sieve; if a coarse aggregate, at least 10 per cent shall be retained in the same manner.

This table shows a considerable reduction in the amount of cement required as compared with previously published tables, especially when combined with the larger sizes of aggregates. As an illustration, the quantities used today for a 1:2:3 mix, with sand up to No. 4 and stone from No. 4 to 1½ ins. are 1.74 bbls. cement; 0.52 cu. yds. sand and 0.77 cu. yd. of stone, while Prof. Abrams' table calls for 1.61 bbls. cement, 0.47 cu. yd. sand and 0.72 cu. yd. stone.

These figures are the exact quantities required for the making of one cubic yard of concrete, and if used will effect a very material saving in the cost of the thousands of miles of concrete roads, pavements and other concrete structures to be built in the years to come.

An allowance for waste, varying for each ingredient and also according to the particular method employed in handling the work, should be added to the quantities given in the table. Professor Abrams is now preparing tables similar to the one already published, for concrete with a compressive strength of 2000 and 2500 lbs. per square inch. As soon as these tables are completed they will be published in the technical press.

Water Content—It is upon studying the water content that we find the most radical change from our previous ideas on the design of concrete mixtures.

Based upon thousands of tests, it has been established that there is a direct connection between the relative quantity of mixing water used and the strength of the concrete, and there is probably no other one factor which has so great an effect upon the strength as the water content.

It has been found that the less water used down to a certain point, the stronger will be the concrete, but this does not mean that we can go too far in reducing the amount of water, nor can we in actual construction reduce it to a point that would give the maximum strength shown in laboratory tests. There is another factor that must be taken into account in construction and that is the workability of the mix. In general terms we can say that the lowest amount of water should be used that will give a workable mix.

The strength falls off very quickly with the addition of a small amount of water; so much so that in a one-bag batch the addition of one pint of water more than is necessary to give a workable mix produces the same loss in strength as if we had left out two or three pounds of cement. Do not think from this that we can use a very lean mix with a small quantity of water and obtain as strong a concrete as a rich mix with the same quantity of water. This is not true, because it will require a higher water-ratio to produce a workable mix with the lean mixture, thereby causing a loss in strength.

The proper consistency for concrete will vary according to the use to be made of it.

The effect of pressure on concrete immediately after moulding is found to be due to the amount of water squeezed out, making a consequent reduction of the water-ratio. Tests were made on concrete of the same proportions, by applying pressure from zero to 500 lbs. per sq. in. The water expelled was carefully collected and measured. It was found the strength increased quite materially with the higher pressures and this increased strength was almost directly proportional to the amount of water squeezed out. We may not be surprised to find, then, that the duration of the pressure had no effect whatever on the strength of the concrete. Whether pressure was applied for a few minutes or for several hours, the effect produced was exactly the same.

It is undoubtedly due to the squeezing out of the water and consequent reduction of water-ratio that produces the excellent results when the roller method of finishing concrete roads is used.

The time that can be allowed between the time of mixing and the time of placing has not as yet been made the subject of extensive tests at the laboratory. This knowledge is of value when considered in conjunction with central mixing plants, which are used with success in many places. The lapsed time is undoubtedly governed to a certain extent by the kind of cement used, by the temperature of the ingredients and by the temperature of the mixed concrete. In Illinois a limit of 40 minutes lapsed time is allowed, but it is generally believed that the economical haul for the job will be the governing factor rather than the fixing of a time limit.

It is possible that some of our present ideas regarding this factor may be changed by the results of such series of tests, but until such a time it would not be advisable to allow retempering of concrete that has been too long in transit, as the addition of water will no doubt result in a reduction in strength.

Protection—The proper protection of concrete during the early hardening period is a detail of construction that is only too often overlooked and many times only indifferently carried out.

The effect of proper curing conditions upon the ability of the concrete to withstand abrasion has been very strongly brought out by numerous tests in the laboratory. There is probably no method of handling concrete that so affects its wearing ability, as that of providing proper protection while curing or hardening.

It is true that any and all of the factors that tend to produce strength in concrete also tend to increase its wearing qualities, nevertheless all of our tests show that other factors being the same the concrete which is properly protected will show much less wear than that which has been allowed to dry out too quickly. As an illustration of this, the strength of a concrete of 1.25 consistency was about 1700 lbs. per sq. in. when it was allowed to dry out in the air unprotected, and exactly the same concrete

stored in damp sand for 21 days gave a strength of about 4000 lbs. per sq. in. and a correspondingly less wear under the rattler test.

One of the principal causes of the poor wearing resistance that we sometimes find in concrete floors is due to the practice of allowing them to dry out without proper protection during the hardening period.

Concrete floors under roof should be covered and kept moist just as outside roads and pavements are protected. Why throw away one-half the life of a concrete floor by failing to observe this rule and holding back from using them for so short a period?

The essential requirements for proper hardening are warmth and the presence of moisture, especially the latter. The test shows a less increase in wearing resistance and strength after 21 days have elapsed and a constant rate of increase during this period. In deciding on the length of time that a pavement, or other structure, shall be kept covered and moist, it is simply a matter of deciding how much of the potential strength and wear resisting qualities it is desirable to throw away and reduce the 21 day period by that amount.

There are several methods of protecting concrete pavements during this period, the most effective of which is the ponding method and where the grades and other conditions will permit this method to be used, it will give the most lasting results. The protection of concrete structures other than pavements is very often either neglected altogether or at best only half carried out. Many times the leaving on of the forms is considered to be sufficient protection in itself, but this is not so.

The forms and all exposed surfaces should be kept thoroughly wet or, at least very moist, continuously for not less than 14 days, and whenever possible for 21 days or more.

Conclusion—I have outlined to you some of the more important developments resulting from our studies at the laboratory with two ideas in mind. First, I wanted to impress upon you the advisability of designing each concrete mixture to produce a concrete of a certain desired strength, with the particular ingredients available. Second, I wanted to show you how the desired results could be obtained.

In reviewing the methods to be employed in obtaining good concrete it appears to me that there are two which stand out above all others, and if these are followed more good will have been done than by following all other refinements put together.

The first of these is: that the least amount of mixing water shall be used that will give a workable mix and not one drop more.

The second is: that no matter with what care we choose the ingredients, proportion them, mix them and place the resulting concrete, we will nullify a considerable portion of the beneficial results of this care unless we keep the concrete moist during the early hardening period.

* * *

Fire's Weekly Toll in the United States

It is said that every week in the year fire destroys in the United States alone: 1,600 dwellings, 3 theaters, 3 public buildings, 12 churches, 10 schools, 150 apartment buildings, 2 hospitals, 26 hotels, 2 college buildings, 3 department stores, 2 asylums, 2 jails.

The total of this destruction averages almost \$10,000,000 a week, but worst of all is the toll in human life. Each week 300 lives are sacrificed to the ravages of fires.

This vast waste of life and property is due to carelessness and improper fire prevention and protection.

Competition for Plans and Equipment of a Model Kitchen

CONSIDERABLE local interest is attached to the recent competition for the best plan and equipment for a model kitchen, conducted by the Hoosier Manufacturing Company, by reason of the fact that an Oakland firm of architects, Messrs. R. O. Hutchison and R. L. Mills, participated in the contest, and a picture of their excellent plan is shown herewith, together with a plate of the prize-winning plan.

Following is an extract from the report of the jury, of which Mr. Herbert Foltz, F. A. I. A., was the professional advisor:

We herewith hand you the report of the jury on the drawings submitted in the competition of the plan and equipment of a model kitchen conducted by the Hoosier Manufacturing Company, of Newcastle, Indiana, manufacturers of the Hoosier Kitchen Cabinet.

In making the awards, the decision of the jury hung upon its interpretation of certain general statements in the competition program, the more important of which are here recalled:

"The problem involves the design of a fully equipped kitchen for a family of four or five without a servant.

"The jury will give consideration to the kitchen plan as an effective working unit; to the character of the several items of equipment and their relation each to the other; to the relation of the kitchen to other adjacent parts of a practical house plan; and to the skill and ingenuity displayed in the solution of the problem as a whole. The question of skilfulness in the execution of the drawings will not be considered, though neatness in their presentation is not to be disparaged."

Before proceeding to a judgment of the 343 drawings submitted, the jury formulated an opinion concerning what certain of the phrases of the program meant in terms of plan and arrangement.

"Family without a servant" implied that the kitchen must be self-contained, complete, capable of fulfilling its function without a pantry. It implied a small kitchen in a comparatively small house. Nor should the operation of such a kitchen depend on the use of special equipment, unusual materials, or features which are not to be readily procured in the open market.

"Effective working unit" implied that there is a definite procedure which should be followed in the use of the kitchen—the preparation, the serving, and the clearing away of a meal. In terms of plan, arrangement and items of equipment, the jury interpreted this phrase to mean a sequence in the use of equipment in preparing a meal, as follows: Refrigerator, kitchen cabinet, range, serving table, to dining room; the sequence of use following a meal, from dining room to table or counter for soiled dishes, sink, drain board, china closet, all so arranged that work goes on from right to left, leaving the dishes after drying in or adjacent to the dining room. That is to say, clearing away should proceed from and return to the dining room in a direction opposite to the movement of the hands of a clock, or "anti-clock-wise." This movement of the dishes was generally disregarded by the competitors. The phrase "effective working unit" also implied the provision of ample light from sources which would also provide a cross circulation of air.

The phrase in the program, "the relation of the kitchen to other adjacent parts of the house," was given a broad interpretation. To the jury this meant that the essentials of the scheme should be contained within a simple, preferably rectangular, arrangement of the walls surrounding the kitchen. Thus only could the arrangement be applied generally. As to the location of the doors connecting the kitchen with other portions of the house, the jury was satisfied on this point when a design was such as to lend itself to arrangements usually found in houses of this general category.

It was upon the foregoing summarized basis of interpretation that the work of elimination proceeded and upon which the following choice of designs was made. Because of the difficulty in reaching a decision as to the four best designs for mention out of the six last remaining drawings, suggestion was made that these six designs be mentioned, which suggestion was accepted by the Hoosier Manufacturing Company.

First Prize, \$500. A. Thompson Thorne, Tulsa, Oklahoma.

Second Prize, \$200. Linden LaRue Perrine, Washington, D. C.

Third Prize, \$100. Oscar T. Lang, Minneapolis, Minnesota.

Fourth Prize, \$50. Mary Drago, Gibsland, Louisiana.

Mentions regardless of rating, \$25 each: William Berg, New York City; Louis Cowles, Santa Rosa, California; Mrs. William Favrao, Springfield, Mass.; Elmer E. Nieman, Colorado Springs, Colo.; Ellis J. Potter, Detroit, Mich.; E. D. Townsley, Ithaca, New York.

== DESIGN FOR A SMALL FAMILY ==
 - MODEL KITCHEN -
 - AS SUBMITTED IN THE -
 HOOSIER MANUFACTURING COMPANY'S -
 COMPETITION -



- PERSPECTIVE VIEW -

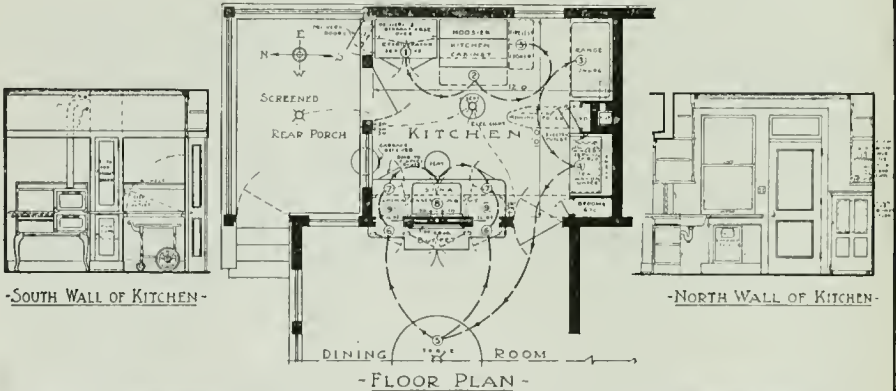

- SOUTH WALL OF KITCHEN -

- NORTH WALL OF KITCHEN -

- FLOOR PLAN -

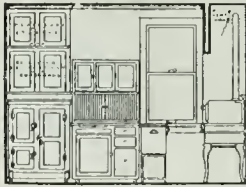

- EAST WALL OF KITCHEN -

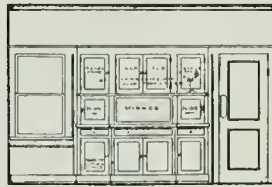

- DINING ROOM SIDE OF CASES -

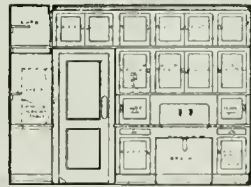

- WEST WALL OF KITCHEN -

- SCALE IN FEET -

DESIGN FOR A SMALL FAMILY MODEL KITCHEN. SUBMITTED BY A. THOMPSON THORNE, TULSA, OKL.

Some Architectural Acrobatics

THOSE who have watched the vast quantity of cement that has been poured into the foundation of the new Hibernia bank building in New Orleans have wondered "how much are they going to put in before they're finished?" Here is the answer—3,650 cubic yards. If that amount of concrete was made into a single stick one foot square, it would take a man walking seven hours to step the distance.

This weight is supported on 3,153 piles, which were driven into the ground until the tops were 16 feet below the sidewalk. These piles are 50 feet long, and if placed end to end would measure a mere matter of thirty miles of solid timber. Sufficient to rail off the famous sailing course over which the Shamrock IV and Resolute raced for the America cup!

The new building will be of modern and beautiful design, rising 23 stories above financial New Orleans. The top of the tower will be 345 feet above the sidewalk. But within the building will be seven passenger elevators, electrically operated, gearless, traveling at a speed of 600 feet a minute. Thus, the tower will be only 30 seconds from the street—via the Hibernia express! Smooth running—no chance of losing your breath. Particularly as within the building will be 4,000,000 cubic feet of free air for breathing purposes!

The steel frame of the building will weigh approximately 3,500 tons. The largest column weighs 550 pounds per lineal foot. It is 46 feet long, a total weight of 25,000 pounds. This little piece of refined iron will carry a load of 1,475,000 pounds, resembling the heavy column of the Woolworth building in New York. The girders which carry the court walls above the banking rooms have a clear span of 45 feet and are seven feet six inches over all. Each of these fellows weighs 35,000 pounds.

All of this tremendous weight is carried on that little concrete foundation resting on those few piles. The prescription for mixing the concrete was 4,000 tons of gravel, 1,400 cubic yards of sand, 125 tons of steel reinforcement, and 5,500 barrels of cement.

The stone columns of the main entrance of the building are monolithic, 30 feet long and three feet nine inches in diameter, weighing 18 tons each.

The vault door of the new building will measure only eight feet in diameter, but it will tip the scale at 80,000 pounds. Even the solid bronze doors of the main entrance will be one ton each!

* * *

Billions for Construction This Year

Early resumption of home building and other forms of construction is assured if contemplated building projects reported by the F. W. Dodge Company may be taken as a criterion for the coming year.

Reports from this company show that contemplated building projects for the territory north of the Ohio river and east of the Missouri will probably reach the tremendous amount of \$4,800,000,000, which under normal conditions would indicate actual construction during 1921 of approximately \$3,200,000,000.

The low lumber market now prevailing paves the way for a big reduction in building costs. Thousands upon thousands of homes, so badly needed, will be built under these conditions. This will necessarily call upon thousands of men from all trades for the production of building materials.

Such demands will naturally lead to steady production and universal employment, which in turn will make for better business activity and general prosperity.

Department of Safety

Conducted in the Interests of the Building
Public and with the Co-operation of the
California Industrial Accident Commission

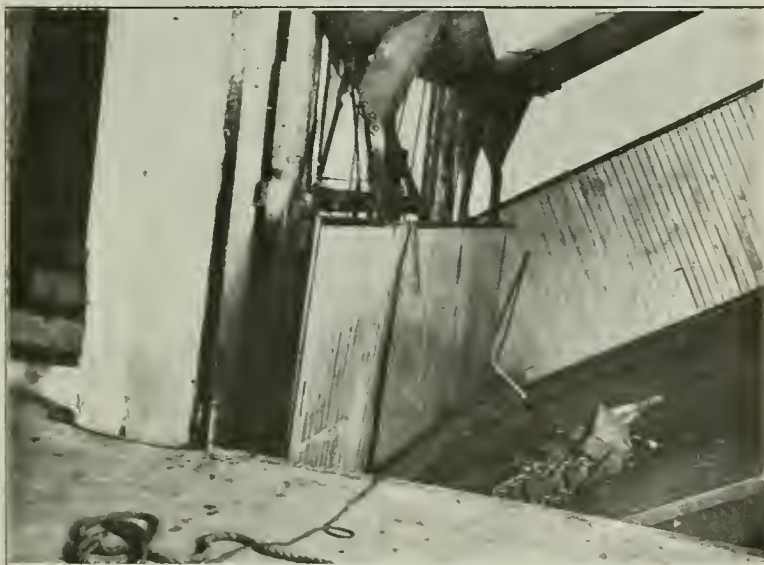

APPEARANCE OF ELEVATOR AFTER TEST.

An Unsuccessful Drop Test

By D. J. HARRIS,

Inspector Elevator Division, California Industrial Accident Commission

THE accompanying photographs aptly illustrate a type of accident which may be entirely eliminated through strict conformity with the Elevator Safety Orders of the California Industrial Accident Commission.

Elevator Safety Order 324 (i) provides that all types of elevator safety devices be subject to an actual drop test in the presence of an authorized representative of the Safety Department.

A drop test consists in raising the car with capacity load aboard, to a height in the hatchway sufficiently great to permit of a free fall. A sling of manila rope approximately two inches in diameter, or a five-eighths-inch steel cable is then passed around the overhead beams and the top of the car



GRIPPING PORTION OF SAFETY DEVICE.

frame, and made fast. The car is then lowered until the combined weight of the car and load is suspended by the sling, allowing the hoisting cables to become slack. The hoisting cables are then removed, and the sling cut, allowing the car and load to drop. It should come to rest in from two to nine feet, dependent upon the type of safety used, providing the governor and safety are of satisfactory construction and actuate properly.

The accompanying photographs were taken of an elevator used for handling automobiles. It serves five floors, having a rise of forty-six feet. The platform was thirteen feet six inches by twenty feet.

It may be readily realized what the result would have been to an automobile and passengers, had the ropes parted when the car was at the top landing, instead of fourteen feet from the bottom, where this test was made. Needless to say the test was unsuccessful, and this governor and safety were ordered replaced by one of a type that had been tested and approved by the Commission.

A Preventable Fatal Construction Accident

By J. J. ROSEDALE, Construction Engineer

On July 6, 1920, a foreman plasterer, 36 years of age, fell 25 feet from a pole scaffold while working on a garage under construction in San Francisco.

The deceased stepped on a loose plank which had no supports at the ends, causing him and the plank to fall to the sidewalk. This pole scaffold was flimsily constructed and contained the following dangerous conditions:



FLIMSILY CONSTRUCTED SCAFFOLD WITHOUT RAILINGS OR TOEBOARDS.

1. The uprights were made of 2-inch by 4-inch common lumber spaced about 7 feet by 6 inches center to center. These uprights should have been made of at least 4-inch by 4-inch clear merchantable lumber.

2. The ledgers were made of $\frac{3}{4}$ -inch by 4-inch and 1-inch by 6-inch common lumber and only two such ledgers were used on about half of the scaffold at each point of support. These ledgers should have been made of either one piece of 2-inch by 6-inch, securely fastened at each point of support, or should have been made of two pieces of 1-inch by 8-inch, one piece on each side of the post or upright, and fastened securely at each point of support.

3. The platform consisted of only three planks, the dimensions of which were $1\frac{1}{2}$ inches by 10 inches and $1\frac{1}{2}$ inches by 12 inches. These planks were not laid closely together and adequately secured to prevent them from slipping or tipping. Some of the planks were spaced from 3 inches to 6 inches apart and were not supported at the ends by ledgers. This dangerous condition caused the plank on which the deceased was working to tip.

4. The scaffold was constructed of a very inferior grade of lumber. Most of this lumber had already been used before and contained a great many knots and cracks. There was no guard rail or toeboard on the outside of the scaffold.

5. The platform of this scaffold should have been at least 4 feet in width, constructed of planks at least 2 inches thick, laid closely together and adequately secured to prevent them from slipping, tipping or collapsing. The platform should have been supported by putlogs or ledgers, nailed securely to the posts. A standard railing 3 feet 6 inches in height and a toeboard 10 inches high should have been provided on the outside of this scaffold.

The cost of this accident for compensation and burial expenses was \$5,600. A substantial scaffold as required by the above safety orders would have cost \$100 more than the one shown in this article.

**THE
Architect and Engineer**

INCORPORATED

Founded 1905 by E. M. C. WHITNEY
 W. J. L. KIERULFF - *President and Manager*
 FRED'K W. JONES - *Vice-Pres. and Editor*
 L. B. PENHORWOOD - *Secretary*
 T. C. KIERULFF - *Attorney*

ASSOCIATE EDITORS

IRVING F. MORROW - *Architectural Critic*
 CHAS. H. CHENEY - *City Planning and*
 } *Book Reviews*
 WILBUR DAVID COOK, *Landscape Architecture*
 WM. B. GESTEK, *Inspection and Tests*
 O. P. SHELLEY, C. E. } *Fireproof Construction*
 F. W. FITZPATRICK, }
 T. RONNEBERG, C. E., - *Structural Steel*
 W. H. LOWE - *Roofs and Roofing*
 FRED'K N. WOODS, JR., - *Rock and Gravel*
 W. H. GEORGE - *Cement*
 CHAS. FELIX BUTTE *Electrical Construction*
 H. J. BRUNNIE - *Reinforced Concrete*
 I. W. FRICKE, - *School Equipment*
 C. H. WHITE - *Hardwood*
 WILL I. FRENCH, *Department of Safety*

**Published Monthly in the Interest of the
 Architects, Structural Engineers, Contractors
 and the Allied Trades of the Pacific
 Coast by The Architect and Engineer, Inc.**

BUSINESS OFFICE AND EDITORIAL ROOMS
 627-629 Foxcroft Building, San Francisco
 Telephone Douglas 1828

Los Angeles Representative: Bert Butterworth Agency, Citizens Bank Building, Los Angeles.

Portland office: 210 Stock Exchange Building, Portland, Oregon.

The publishers disclaim any responsibility for statements made in the advertisements of this magazine

TERMS OF SUBSCRIPTION

(Including postage) to all parts of the United States \$7.50 per annum; to Canada 75c additional; to all Foreign points \$1 additional

Vol. LXIV. January, 1921 No. 1

THE GOLDEN OPPORTUNITY

The building industry has been introspective for four or five years and up to date nothing has been found basically the matter with it. The building industry, by government edict, and by the exigencies of war has passed through a purging fire. In other lines of business the extravagant and the unfit have been able to proceed on account of unusual demand and the general pyramiding of prices and now that the prices have begun to fall, possibly many of the unstable, small-minded, careless and unfit business men will fall too; but the building industry has been freed from all such circumstances, what is left is sound and stable, and now is about to enter upon its great era of prosperity.

"Those who take all they can get today risk the loss of all they have tomorrow." Doubtless a few elements in the building industry have so acted. Those who rose the highest

on the wave of price increases will possibly feel the greatest drop. It is well known that little profits never harm any business. The building industry is the largest but one and deals with the most fundamental property values and the most basic securities of our national wealth. The building industry could, if it would, hew the profits to the bone and hold the whole craft of business and industry on a steady keel, and it behooves every one connected with it to drop any idea of panic and begin at once in the closest co-operation to go on with the work with the least possible profit and overhead expense.

The way to resume building is to build. If for a brief time the banks, in their race for "all they can get," overlook the value of the building industry, let the building interests get together and devise other and possibly safer financial plans. The little savings of individuals put together make great ownerships. If those savings, gathered by the banks, are diverted to consumable and speculative investments for the time being, let the building industry, without waiting for the banks to disgorge, institute a strong team-work drive for individual initiative in building ownerships, gather what individual capital is left here and there, organize co-operative ownerships and go ahead. It is the golden opportunity for the building and construction industry to save the nation's welfare and thus save itself.

HENRY K. HOLSMAN.

DEVELOPMENT OF ARCHITECTURAL PRACTICE

More publicity seems to be the watchword of the American Institute of Architects in its endeavor to educate the public into appreciating and utilizing the services of the profession. Various methods of accomplishing this have been under discussion for some time. A few architects have proceeded on their own initiative by experimenting with newspaper advertising. It cannot be said that the results have been over gratifying.

Mr. Taylor, in the Architectural Forum, offers a few constructive sug-

gestions, and recommends one method of activity which he thinks would materially assist in developing local practice. Briefly, he says:

We have in mind the possibility of forming local groups of architects co-operating to produce general publicity which will promote in the public mind a better conception of the value of architectural service, both to the individual and to the community.

In traveling through various smaller cities and towns * * * it is amazing to note the lack of architectural merit in the designs of dwellings, small store groups and other smaller types of construction. Naturally, many comments have been made regarding such conditions, but it is also evident in starting new construction that very little progress is being made in impressing owners and communities as to the value of architecture applied not only to the design of individual dwellings, but in relation to unity of mass, which is so lacking even in the newly constructed residential and business sections of our cities and towns. * * *

The development of really good stock plans for homes which has been carried out through various manufacturers' associations and through the activities of certain publications has had beneficial influence on the less expensive domestic architecture of the United States. The fact, however, that a very large percentage of this construction is carried out without the services of good architects is plainly evidenced in a study of new building developments of a residential character.

The same criticism may be made of store blocks, usually two stories in height, containing space for several stores and possibly residential quarters for storekeepers' families. Here and there one may see a new store block which has character and consequently attractiveness. Casual inquiry seems to show that in blocks of this kind store rentals are higher, not because cost of construction is higher, but because atmosphere has been created.

The public at large, and particularly the building public, has no mentor to point out the basic reason why certain houses or certain blocks are more attractive. There is no simple manner through which appreciation in the public mind is being developed regarding the fact that the more attractive units or sections of the community are those which have received architectural study. Consequently, as millions of dollars are being spent in the development of new homes and smaller buildings of various types, there is not an increasing percentage of this work coming under the control of trained designers.

It would seem logical, therefore, that under normal conditions, and particularly in smaller communities, definite co-operation could be carried out among local architects to enter into a campaign of advertising, the purpose of which would be to develop public appreciation in order that prospective builders of homes and smaller building groups might be induced to at least give consideration to the possibility of using good plans, both from an artistic, community and real estate valuation viewpoint. * * *

Suppose a group of local architects were to prepare a number of attractive house plans and offer them to prospective builders in the community at a comparatively low cost. Certainly there would be considerable publicity not only for the architects who entered into such an activity, but for the idea of bettering residential design, and this spirit, once established locally, would result in practical elimination of ugly stock plans and the untrained conceptions of the average builder.

To the lay mind, in considering the construction of an inexpensive home the services of an architect mean added expense. If, however, the architect be of practical mind, he will usually be able to produce a design involving additional features which would more than offset any charge which he might make for the work.

Through the activities of such an organized group of architects real estate developers could be induced to avoid common errors in locating dwellings on subdivisions. With a studied campaign of education carried out along simple and dignified lines of community benefit there can be no doubt that a very large percentage of money to be expended for building construction in the community would carry an architect's commission.

* * * * *

There is no doubt that architects have been somewhat lax in at least one respect—that is, in waiting for prospective builders to learn, through one manner or another, appreciation of the practical, artistic element in the preparation of building plans, and consequently awaiting calls for their services. In other lines of activity demand for services is definitely developed by some more or less scientific plan of publicity.

No serious obstacle can be foreseen which might preclude co-operative activity of this nature on the part of local architects. The actual division of the work would naturally be left to individual selection, but it is certain that if the demand for architectural services can be increased through the development of public appreciation, there would be more work to go around, and consequently more work for the individual architect.

Electrical Department

Theatre Equipments on the Pacific Coast*

By CHARLES FELIX BUTTE

AN ever increasing demand for buildings for theatrical purposes, moving pictures and other types of amusement, have afforded architects opportunities to design structures possessing unique fea-

varies during the various periods of the performance. How to evolve a satisfactory scheme to meet these conditions has been a problem for many architects. In order to harmonize the illuminating scheme with the decorative scheme in a number of instances, coves have been provided for concealing the sources of light. This method has proved very satisfactory, but further developments have added a center fixture of large diameter with concealed lighting placed therein. The center fixtures are made of ornamental plaster with perforations and are placed under the ventilating outlet. They serve two purposes, providing means of concealed distributed light and ornamenting the usual flat ventilating grill. The interiors shown herewith illustrate the two methods very well. The distribution of the lighting is so arranged that varied colored lights can be thrown on, giving a beautiful glowing effect in the auditorium. In addition to the color lighting arrangement, dimmers are provided which make it possible to vary the intensity of the illumination at will, also changing the tone of the color as may be desired.

The exterior of the building must attract attention and individualize the loca-

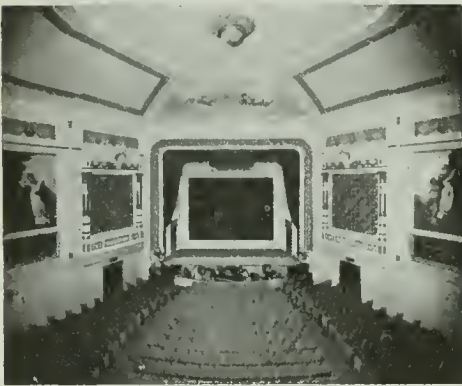

NEW LYCEUM THEATRE, SAN FRANCISCO
Reid Bros., Architects

tures heretofore not attempted. Present-day demands of the public call not only for modern conveniences, but unusual effects in design and equipment.

The structural details and artistic embellishments must at all times be pleasing to the eye and must harmonize with the illuminating scheme during the period of the picture projection and while the interior is brilliantly illuminated. The interior details and decorative scheme should be so designed as to appear pleasing to the eye while the theatre is lighted and also during the period that the auditorium is dimmed. To meet these conditions the architect must give this portion of the structure much study that he may produce an interior scheme in perfect harmony with the conditions that prevail at various times. The problem would not be so difficult if only one condition were imposed, but the fact remains that particularly in motion picture work, the illuminating scheme

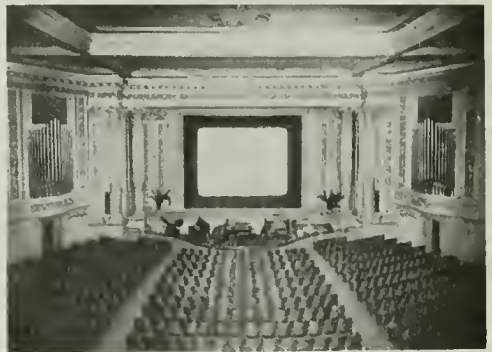

NEW MISSION THEATRE, SAN FRANCISCO
Reid Bros., Architects

*First of a series of articles describing modern theatre equipments on the Pacific Coast, with special reference to the electrical installations. The author personally supervised the electrical work in the buildings described. The electrical equipment and mechanical arrangements in various California theatres will be described in the next article.



COLISEUM THEATRE, SAN FRANCISCO
Reid Bros., Architects

tion of the theatre. The exterior decorative scheme and architectural details must be attractive in the day time as well as night. In many theatres, floodlighting has been provided to flood the front of the building at night to illuminate the

architectural details of the facade. The details of ornamentation must be designed, in the event that flood lighting is used, to prevent distortion by shadows during the period that the flood lights are in use.

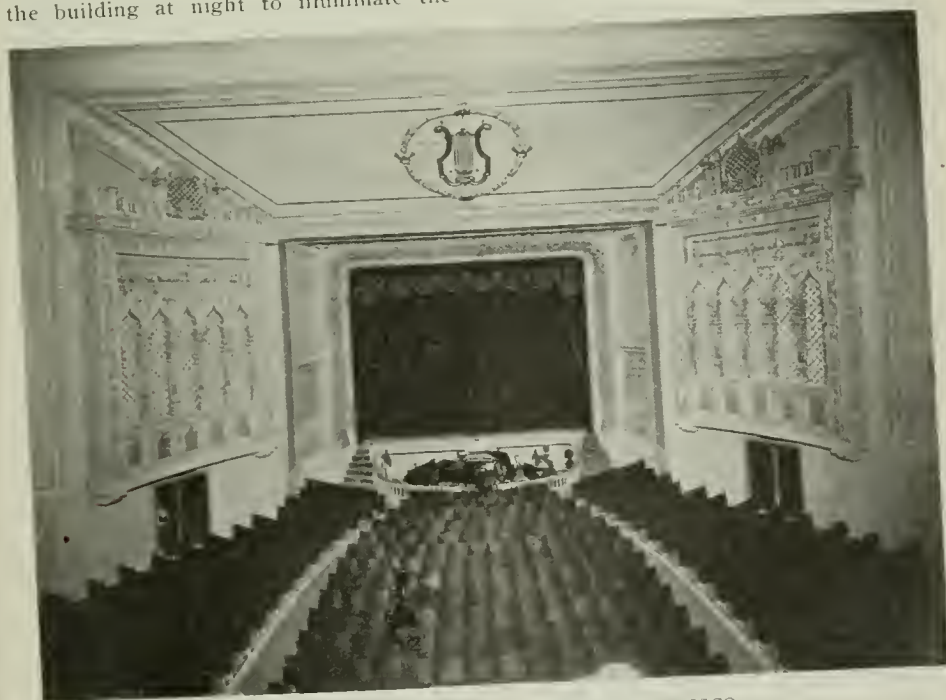

INTERIOR, COLISEUM THEATRE, SAN FRANCISCO
Reid Bros., Architects

The main entrance to the theatre is a very important subject, as it is human nature for a person to go into a theatre that appears pleasing; it is, therefore, advantageous to owners that the public be given a favorable impression of his playhouse before entering.

In many instances insufficient thought has been given to the seating arrangement of the balcony, in relation to the structural details that must be provided for carrying the loads, to prevent interference with the vision of the patrons. Columns supporting the balcony where necessary, should be so placed that the line of vision from any seat is not interfered with. The angle of vision of the seats close to the proscenium arch should be so arranged that the view of the stage or picture is not cut off. Considering the comfort of the patrons of the theatre, sufficient space should be allowed between the seats to prevent inconvenience in so far as the passing of patrons in front of one another is concerned. The comfort of the patron should also be taken into consideration in establishing the distance between the chairs. The shape and style of chair is a very important point to be considered as the restfulness of the chair will create a feeling of satisfaction to the patron. The elevation of the various rows of chairs in relation to the stage level is another very important factor to be considered as the vision of the patrons will be interfered with if the auditorium pitch is improperly calculated.

The details of ornamentation of the proscenium arch and the relative arrangement of the curtain and screen in relation thereto, if not designed by an architect experienced in the designing of theatre buildings may result in a serious disappointment upon completion of this portion of the interior. The patrons of the theatre during the period of attendance will at all times look at the proscenium arch. Any harsh designs or over embellishment scheme that exists will detract from the performance on the stage or on the screen and result in dissatisfied patrons, no matter how well the actors may perform or how interesting the picture.

The arrangement of the musicians' pit in relation to the level of the auditorium floor and the stage is becoming a point of vital importance, particularly as the demands made upon motion picture houses for orchestral numbers is increasing. The architectural details surrounding the pit must harmonize with the general scheme of the proscenium arch and make a pleasing appearance to the eye of the patron.

The level of the orchestra pit in many instances has been raised within six inches of the level of the auditorium

floor at the orchestra pit line. The reason that the orchestra pit floor level has been raised above the levels established in the past, is the fact that the audience appreciates the selection rendered a great deal more when they can observe the musicians. The latter also take more interest in the selections when they are within view of the audience.

Considerable discussion has taken place regarding the arrangement of the entrance and entrance lobby leading to the auditorium proper. The consensus of opinion is that where conditions will permit it is best to provide an outer and an inner lobby. This arrangement is particularly of value to a theatre displaying motion pictures as the patrons on entering the outer lobby meet an illuminated area of the same intensity as the exterior light, and upon entering the inner lobby meet a graduated illumination that is equal to the auditorium lighting upon entering the auditorium. It can be readily seen that the eye strain of a patron caused by immediately entering the auditorium from the brilliantly lighted street or daylight is avoided by the long lobby. The reverse of the above holds true when the patron leaves the theatre, and the eye strain caused by leaving the dim auditorium and entering the brilliant street light, is avoided by the graduated illumination of the lobbies.

These requirements cannot always be met as the structural conditions prevailing will not provide for a long lobby. Aside from the advantage to the patron in the case of the long lobby, provision is made therein to take care of the waiting patrons and avoids the congregation of the patrons at the entrance door.

The arrangement of the rest rooms on the mezzanine floors in many of the theatres creates a home like surrounding and the interior hangings and furniture of this portion of the theatre are exceedingly elaborate in many of the present day motion picture theatres. The arrangement of these rooms in relation to the incline and entrances to the balcony should produce a promenade effect. In a number of instances the beautiful surroundings of the mezzanine floor and the incline to the balcony create a desire on the part of many of the patrons to enter the balcony rather than the first floor, as the promenade effect produces a very pleasing effect on such patrons. The accommodations provided for the patrons should be of the highest character and any expenditures made in this respect are fully justified by the attraction of permanent patrons to the theatre. The present day theatre depends more and more upon the permanent patrons, and any provisions that may be made to accommodate them should be embodied in the original structure.

With the Architects

Building Reports and Personal Mention of Interest to the Profession

Miller and Warnecke Busy

Messrs. Chester H. Miller and Carl I. Warnecke, Perry building, Oakland, report prospects excellent for a good year. Plans are being prepared for a \$40,000 addition to the Hotel Taylor at Paso Robles; a \$60,000 store and office building for Mr. W. C. Henderson in Paso Robles, the structure to be two stories high, of brick, and will contain approximately fifteen offices and two stores; an addition to Mr. Henderson's garage on Spring street in the same town; a one-story brick tailor shop for the Paso Robles Tailoring Company, and alterations to the Blackburn building. Besides the work in Paso Robles the firm has six houses in Sunnyside, San Francisco, to cost \$4,000 each, and plans are on the boards for the new Rockridge school in the city of Oakland, for which there is an appropriation of \$68,000. Plans are complete and construction is expected to start at once on extensive alterations and additions to the Kellogg Estate building at Fifteenth and Grove streets, Oakland. Bids have been taken and are under advisement.

Memorial Auditoriums

Mr. W. H. Ratcliff, Jr., Berkeley architect, has prepared preliminary drawings for a war memorial auditorium for the American Legion to be built east of the Berkeley city hall at an estimated cost of \$275,000.

Messrs. Morrow and Gerin of San Francisco have been commissioned to prepare plans for a Community club house and auditorium for the Kelseville Post of the American Legion. Funds for the structure are now being raised.

Large Apartment House

Mr. Joseph L. Stewart, architect, in the Claus Spreckels building, San Francisco, has prepared plans for a four-story and basement reinforced concrete loft building to be erected on First street, near Mission, San Francisco, for the Moss Glove House. Mr. Stewart has been commissioned to make plans for a large apartment house in Santa Monica to cost in excess of \$500,000.

Museum and War Memorial

Mr. G. A. Applegarth, Claus Spreckels building, San Francisco, is preparing working drawings for a museum and war memorial to be built in Lincoln Park, San Francisco, for the California Legion of Honor. The design is to be French Renaissance, and construction will be of concrete and stone. The edifice will cover ground area 175 by 275 feet.

Mr. Applegarth is also working on preliminary drawings for a nine-story community apartment house for Jackson and Laguna streets for Mr. Frank Thornburg and associates.

Designing a Bohemian City

Messrs. William Curlett & Sons, Merchants National Bank building, Los Angeles, are preparing plans for a Bohemian City to be erected on a 20-acre tract at Melrose and Western avenues, Los Angeles, for Mr. Oliver Morosco and associates. The principal structure will be a theatre to seat 2500 people. There will also be an art gallery, cafes and other amusement places. The buildings will be of reinforced concrete, brick and frame, and will represent an expenditure of several million dollars.

Two Portland Buildings

Messrs. Lawrence & Holford, Chamber of Commerce building, Portland, have drawn plans for Grace Memorial Church, to cost \$60,000. The edifice will be of brick. Plans have been completed by the same architects for a \$60,000 concrete garage for Herbert Gordon, president of the Lawyers Title and Trust Company, Portland, Oregon.

Designing Berkeley Homes

Mr. John H. Thomas, First National Bank building, Berkeley, has prepared plans for two residences—one for Mr. Thos. H. Gerdtts at Thousand Oaks, to cost \$7000, and the other at Claremont for Mr. C. A. Ferrin, to cost \$10,000.

\$600,000 High School

Messrs. W. H. Weeks of San Francisco and Robert H. Orr of Los Angeles have been commissioned to prepare plans for a \$600,000 high school building at Pomona, in Southern California.

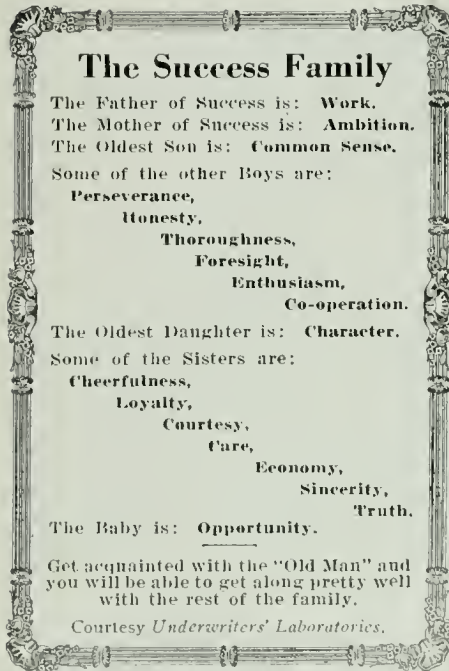

Personal

MESSEURS. HORNOSTEL, EDMUND M. ASHE and JOSEPH BAILEY ELLIS have been appointed members of the faculty of the Carnegie Institute of Technology, division of arts. Mr. Hornostel, formerly a member of the architectural firm of Palmer & Hornostel, New York City, has been made professor of design.

Architect Sues for Fee

The suit of Mr. Sidney B. Newsom, a San Francisco architect, against Mr. James McMullen of Richmond, by which the plaintiff seeks to recover \$540 alleged to be due for preparing plans and specifications for a building in that city, was tried before Judge R. H. Latimer and the matter was taken under advisement by the court.

Examination for Architects

The next examination for architects in the State of Idaho will be held in the office of the Department of Law Enforcement March 8th. For application blanks and full information concerning this examination, address Bureau of License, Boise, Idaho.

Western Addition Garage.

Mr. Earl Scott has prepared plans for a two-story and basement reinforced concrete commercial garage to be erected on Polk street in the Western Addition of San Francisco at an estimated cost of \$40,000.

Store and Bank Buildings

Messrs. Barrett and Hilp of San Francisco, have been awarded contracts this month for the construction of two buildings of considerable importance—one a two-story reinforced concrete store and loft building on Mission street, near First, San Francisco, for Mr. Walter H. Sullivan, from plans by Mr. Leo J. Devlin, and the other a concrete bank building at Daly City, from plans by Mr. W. H. Toepke.

To Design Stadium.

Mr. Myron Hunt, 1107 Hibernian building, Los Angeles, has been commissioned to prepare plans for a large stadium to be erected in the Arroyo Seco at Pasadena for the Pasadena Rose Tournament Association. Mr. A. J. Bartonneau is chairman of the stadium committee. The stadium will be designed to accommodate the thousands of people who witness the annual New Year's football game and other events.

Granted Certificates

At the regular monthly meeting of the California State Board of Architecture (Northern Branch) December 28, 1920, the following were granted certificates to practice architecture in this State:

Edward W. Peterson, Fresno, Cal.; T. Kurahashi, Consular building, San Francisco; Ferris Le Roy Francisco, formerly New York City; Robert E. Jacobus, formerly New York City.

Stockton Comfort Station

Mr. Ralph P. Morrell, architect, of Stockton, has been commissioned to prepare plans for a reinforced concrete and enamel tile comfort station to be built under the Court House grounds in Stockton for the San Joaquin County Supervisors. An appropriation of \$20,000 has been made.

To Design County Jail

Mr. C. H. Biggar, Morgan building, Bakersfield, has been commissioned to prepare plans for a new county jail building to be erected on the court house site at Bakersfield. It will contain fifty cells. The present county jail will be remodeled into an emergency hospital.

Sacramento Bank Building

The H. H. Winner Company of San Francisco has prepared plans and will manage construction of a two-story and basement reinforced concrete bank building on Seventh street, Sacramento, for the newly organized Merchants National Bank of that city. The estimated cost is \$75,000.

Architects Named for Los Angeles Schools

The Los Angeles Board of Education has commissioned the following architects to prepare plans and specifications for new school buildings:

Barton Hill, 8 rooms, \$72,000; Montgomery & Nibecker, architects.
 Belvedere, 8 rooms, \$72,000; Train & Williams.
 Breed street, 10 rooms, \$90,000; Norenberg & Johnson.
 Buchanan street, 8 rooms, \$72,000; Montgomery & Nibecker.
 Budlong avenue, 4 rooms, \$36,000; Rea & Garstang.
 California street, 8 rooms, \$72,000; C. F. Skillington.
 Custer avenue, 8 rooms, \$72,000; Hunt & Burns.
 First street, 12 rooms, \$108,000; Krepml & Erkes.
 Santa Monica avenue, 4 rooms, \$36,000; Parker O. Wright.
 South Park avenue, 8 rooms, \$72,000; Walker & Eisen.
 Utah street, 12 rooms, \$108,000; Albert C. Martin.
 Vine street, 12 rooms, \$108,000; Witmer & Watson.
 Wilton Pl., 14 rooms, \$126,000; will be designed by Edgar H. Cline, the school board's architect.

Washington State Society Elects

The Washington State Society of Architects held its annual election in Seattle on December 7th and re-elected the old board of officers as follows: Messrs. Harry H. James, American Bank building, Seattle, president; Clayton D. Wilson, Mutual Life building, Seattle, first vice-president; Julius Zittel, Spokane, second vice-president; Watson Vernon, Aberdeen, third vice-president; Richard V. Gough, Okanogan, fourth vice-president; Edgar Blair, Epler building, Seattle, secretary, and L. L. Mendel, Empire building, Seattle, treasurer. The new board of trustees consists of Harry H. James, chairman, Frank H. Fowler, A. Warren Gould, Wm. J. Jones and R. H. Rowe.

Architects in New Offices

Mr. N. W. Sexton of San Francisco has moved to new offices on the sixteenth floor of the Chronicle building. Mr. Sexton has considerable new work on the board, including a two-story and basement mill construction warehouse for the San Francisco News Company to be erected on Howard street, at a cost of \$100,000. Preliminary drawings are also being made by Mr. Sexton for a high school building in Northern California.

Mr. Walter Parker has moved his offices from Pine street to the Mechanics Library building, San Francisco. Mr. Parker has just completed plans for two new school houses in Mill Valley.

Kansas to Use California Act as Model

Kansas will use the California State Land Settlement Act as a model for a system of land colonies similar to those in this state.

Portland Competition Decided

Messrs. Sutton & Whitney, architects, with offices in the Lewis building, Portland, Oregon, won first prize in the competition held recently for a design for a Scottish Rite cathedral.

The winners were given \$1,000 and are to receive the commission to prepare the plans and specifications for the proposed structure, which will cost in excess of \$1,000,000.

The edifice planned by Messrs. Sutton & Whitney is to be 190 by 220 feet in dimensions and 100 feet in height. The exterior walls are to be of brick and terra cotta. The structure is of a rather severe type of architecture, symbolic of Masonry.

Judges selected to appraise the merits of the plans submitted were: Messrs P. A. Malcolm, A. M. Wright, W. C. Alvord, Louis G. Clarke, all of Portland, and W. R. B. Wilcox, a Seattle architect. Mr. W. G. Purcell assisted the judges as an architectural adviser.

Second prize in the contest, consisting of \$600, was awarded to Messrs. W. C. Knighton and Morris Whitehouse, and a third prize of \$400 was won by Mr. Richard Martin, Jr. There were six Portland architects in the competition, all of them being Scottish Rite Masons.

Architect Brings Suit

Five hundred and fifty-seven dollars and fifty cents is asked of the city of Colusa by Mr. Martin A. Sheldon, a San Francisco architect, in an amended complaint filed in the Superior Court at Colusa.

Mr. Sheldon claims this amount is due him for fees for work on the municipal swimming pool. He details his bill as follows: Traveling expenses, \$80; salary of self and draughtsman, \$330; designing, \$75; obtaining mechanical and structural data, \$92.50.

Returns From Paris

Mr. and Mrs. Arthur Brown, Jr., have returned to California after an absence of six months abroad. Most of their visit was passed in France and during that time Mr. Brown received the cross of the Legion of Honor in recognition of his architectural achievements. He also holds the distinction of having been made a member of the Institute of France, the honor having been bestowed upon only one other American architect, Mr. Whitney Warren of New York.

Architectural League Exhibition

The Architectural League of New York will hold its Annual Exhibition of Architecture and the Allied Arts in the unfinished south wing of the Metropolitan Museum of Art, New York City, March 25 to April 26, 1921. Mr. Lawrence Grant White is secretary.

American Oak Floors are the Best

The architect employed to draw the plans of a building is the first one concerned about what kind of floors should be specified. The community judges him by the quality of his work. The builder, who builds well, finds an increasing demand for the buildings he erects; the owner, who builds a house in which to live, gets the greatest satisfaction out of a house that is well built and of a pleasing and dignified appearance.

A home well floored is half furnished. There is nothing that gives a home a more distinctive or individual look than oak flooring. Oak flooring also gives a building extra commercial value and a salability this goes with distinctive things.

American oak flooring exceeds all others from the standpoint of character and grades, and may be selected to suit conditions. It is very durable, artistic when finished, and can be safely recommended.

On the Pacific Coast there is some Japanese oak being used for cabinet making and for flooring. Its introduction in this country was due to the fact that it could be bought very cheap.

A great deal of this kind of flooring will be found soft and very porous. It indicates its own presence in the finished floor. It is the grain or flower that gives oak its strength. This being much smaller in Japanese oak than in the American, is evidence of its weakness. Much of it can be broken very easily, showing a brashy nature. The broken ends of such pieces show no jagged edges as would be seen in a better material. The very great difference in quality between American oak and that imported from Japan is probably due to the climatic conditions affecting the main source of the Japanese oak supply—Hokkaido Island—and to the nature of the soil in which it grows.

Much of the timber is mature or dead. The flooring made from such timber may be bright in color, yet varying in respect to hardness, finishes unevenly, or, for the want of a better term, looks spotted. That you will get this kind of material, you may satisfy yourself, if you will take the trouble to inspect some of the Japanese oak floors laid in this city.

British firms, who are large importers of hardwoods, say that Japanese oak is not suitable for railway construction purposes; that it is much inferior to American oak, and that it could best be used in the manufacture of fumed oak furniture, for by that process the imperfections might be covered up.

In the United States oak has long been displaced in railroad construction work, either by Douglas, fir from the Northwest or by pine from the South. One transcontinental line after trying out

Japanese oak ties announced that such ties were unsatisfactory and their use would be discontinued. Because of its inferiority, the city of Los Angeles, after a thorough investigation refused to allow its use on the municipal warehouses.

Many contractors and architects refuse to use Japanese oak or specify it. There are instances where it has been substituted and had to be torn up.

Architects' Chapter Elects Officers

Mr. Edwin Bergstrom was unanimously re-elected president of the Southern California Chapter of the American Institute of Architects at the December meeting at the City Club. The other officers elected were: Mr. Henry F. Withey, vice-president; Mr. R. Germain Hubby, secretary; Mr. Robert H. Orr, treasurer; and Mr. D. C. Allison, director.

Amendments to the constitution and by-laws were discussed and adopted, the principal changes being an increase in the initiation fee and annual dues. The executive committee reported that Messrs. Edward Cray Taylor, Los Angeles; W. Horace Austin, Long Beach; and William Templeton Johnson and Richard S. Requa, of San Diego, had been elected to Institute membership.

A very sincere letter from President Kendall of the Institute was read. Mr. Kendall expressed the appreciation of the board of directors of the Institute for the invitation received from the Chapter and other civic bodies and officials of Los Angeles for the Institute to hold its next convention in Los Angeles, but stated that for urgent reasons the board of directors had finally decided upon Washington, D. C., for the annual meeting. Mr. Kendall expects to be in Los Angeles in January and to attend the meeting of the Chapter at that time.

President Bergstrom reported on the activities of the Joint Technical Society and other organizations with which the Chapter is affiliated.

Fresno Firm Busy

The Trewhitt-Shields Company of Fresno reports having contracts for considerable new work to be carried on this year. They will erect a \$350,000 building for the California Peach Growers' Association at Fresno, and later in the year will build an office structure for the Peach and Raisin Growers' Association at a cost of \$300,000. Plans for both buildings will be prepared by Messrs. Glass and Butner, Fresno architects. Messrs. Trewhitt-Shields will also be in charge of construction of the Sanger and Olig grammar school buildings in Fresno county.

With the Engineers

Reports from the Various Pacific Coast Societies,
Personal Mention, Etc.

Engineers as City Managers

The engineers of the State of Washington are looking forward with more than ordinary interest to this year's session of the State Legislature. In addition to the engineers' license bill and the proposed lien law, a bill is being prepared by Senator D. C. Morthland of Yakima, providing that cities up to and including those of the second class may adopt the commission manager form of government. Under this plan three commissioners are elected instead of a mayor and city council and these commissioners select the city manager, who shall have general charge of all departments of the city government.

This form of government has already been adopted by nearly two hundred cities and towns in the United States and has generally proved very successful, none of these cities having abandoned the system. Constitutional amendments permitting this form of government have been adopted by twenty-three states.

It is significant that engineers have usually been chosen as city managers, the broadness of their training having especially fitted them for these responsible positions. The following, with name of city, state, population and amount of salary respectively given, have this form of government: Phoenix, Ariz., 40,000, \$5,000; San Jose, Calif., 40,000, \$6,000; Tallahassee, Florida, 6,500, \$4,200; Eldorado, Kansas, 11,000, \$3,600; Waltham, Mass., 33,000, \$5,000; Crystal Falls, Mich., 7,000, \$3,000; Edgworth, Penn., 2,500, \$3,000; Akron, Ohio, 200,000, \$10,000; Bakersfield, Calif., 20,000, \$4,000; Santa Barbara, Calif., 12,000, \$4,000.

It is unnecessary to emphasize the importance of the bill to all of us, and every engineer should inform himself on the merits and do his part in the campaign for its adoption.

License Law for Montana Engineers

The Montana Assembly of the American Association of Engineers has printed and distributed a proposed license law for engineers and land surveyors which will be introduced before the next Legislature for adoption. In addition to the license bill, the assembly has printed a bill defining the compensation of county surveyors. The first of these two bills prescribes that the county surveyor shall be a professional engineer, not less than twenty-four years of age, who shall either be a graduate of a recognized college with

at least two years' practical engineering experience or an engineer with seven years of experience of which three shall have been in responsible charge of work. The chief deputy, authorized for counties of the first and second class, must have the same qualifications as the county surveyor. All other deputies shall be graduates or else shall have had five years' experience.

The bill on compensation allows a salary of \$3,600 per annum for county surveyors of first and second class counties and \$3,000 per annum for surveyors of other counties. Chief deputies will receive \$3,000 per annum and all other deputies a minimum of \$200 a month.

A. A. E. Gains Many Members

The results of the membership campaign recently conducted by the American Association of Engineers, now officially tabulated, show that more applications were received during the drive, lasting from September 15 to October 30, than the association had members twenty-two months ago. In addition, many more than the usual number of applications have come in since the campaign due to the impetus of the drive. The total number of applications received in the campaign was 3735.

The membership on December 8, 1920, was 23094. It now has 240 chapters and clubs and maintains offices in thirteen cities—New York, Washington, Pittsburgh, Boston, Detroit, St. Louis, St. Paul, Omaha, El Paso, San Francisco, Los Angeles, Seattle and Portland. The association has state assemblies in ten states—Nebraska, Montana, Ohio, Washington, California, North Carolina, Illinois, Arizona and Tennessee. State chapters have been established in Nevada, North Dakota, South Dakota, Minnesota, Idaho and Oregon.

American Association of Engineers

At a meeting of Los Angeles Chapter, American Association of Engineers, December 17th, the constitution of the proposed state assembly for California, was ratified.

Mr. William L. Woollett, architect, read a paper on "The Los Angeles Plan," giving his idea of what it should be.

Mr. D. E. Godfrey has resigned as secretary of the Chapter and the directors have appointed Mr. W. S. Pepper, asso-

ciated with Mr. Paul Kressly, consulting engineer, to fill the vacancy. Mr. Godfrey, who has been connected with the office of the division engineer of the State Highway department in Los Angeles, contemplates leaving the engineering field to embark in other business.

Drop Ladders on Fire Escapes

An amendment to the Los Angeles city building ordinance requiring a drop ladder, counter-balanced stairway or permanent ladder or stairway from the lower balcony of a fire escape to the ground, has been adopted by the city council and became effective January 10th. It is also provided that all existing fire escapes shall be so equipped within one year from that date. Following is the text of the amendment, which is a revision of subdivision (j) of Sec. 157, of the building code:

(j) To the lowest balcony of any fire escape hereafter erected or constructed, there shall be attached a counterbalanced stairway, drop ladder or a permanent ladder or stairway, extending from such balcony to the street, alley or ground.

From and after one year from the date of the passage of this ordinance it shall be unlawful for any person, firm or corporation to maintain or permit to be maintained, any fire escape upon any building in the City of Los Angeles unless there shall be attached to the lowest balcony thereof a counterbalanced stairway, drop ladder or a permanent ladder or stairway extending from such balcony to the street, alley or ground.

Such counterbalanced stairway, drop ladder or permanent ladder or stairway shall be of similar construction and of the same width as the "Standard" fire escape stairways, and shall be designed to carry similar live loads.

The type of all such counterbalanced stairways or drop ladders shall first be approved by the Board of Fire Commissioners, and shall be approved by the Board of Public Works as to construction and erection.

High Class Bungalows

Mr. E. H. Foster of the Rucker Realty Co., San Jose, has purchased the old Spence property at the corner of The Alameda and Fremont street, San Jose, and will erect on the site seven high class bungalows, ranging in cost from \$8000 to \$10,000.

Controversies a Detriment to the Institute

Mr. Willis Polk has sent the following telegram to Mr. Thomas R. Kimball, President of the American Institute of Architects:

SAN FRANCISCO, CAL., December 17, 1920.
Thos. R. Kimball, Esq.,
836 World Herald Bldg., Omaha, Neb.

Objections here to Kansas City program seem to be founded on the general ground that it is not in accord with the code so far as it does not call for a two form submission. Furthermore, objection is set forth that especially invited competitors opens the door to favoritism in their selection. Beyond that the owner's right to select an outside architect to collaborate with the winner of the competition is included in the objections. Personally I do not sympathize with any of these objections. It is not clear to me whether the Nebraska program was open to the same criticism or not. I think you should thoroughly ventilate this matter to make clear that the aim of the Institute should not be confined to the establishment of precedents on narrow lines, and if petty jealousy can voice criticism of the character herein alluded to then it should be the first duty of the Institute to correct the code and broaden its scope so that the little fellow's bark shall not militate against the standing of the Institute in public esteem. Beyond and above all this I believe that controversies of this sort have in the past been detrimental to the whole purpose of the Institute. It is time to stop such controversies. My application for reinstatement in the Chapter and in the Institute is on file, but between ourselves I have no desire to affiliate with organizations from which I have retired because they indulged in practices that destroyed public confidence and opened the door to the assumption by general contractors of the first place in the building world and the retirement of architects to second place. In brief, the history of the Institute seems to have been an assiduous misuse of its prestige for ignoble purposes. I firmly believe that a policy along proper lines with the right kind of propaganda could restore public confidence not only in a national way but local respect could be retained in every community.

WILLIS POLK.

U. S. Civil Service Examination

The United States Civil Service Commission announces open competition examinations for senior engineer, grade 2, which embraces civil, electrical, mechanical, signal, structural, telegraph and telephone architect. Applications should be filed with the Civil Service Commission, Washington, D. C.

HARDWOOD HEADQUARTERS

ASH-BASSWOOD-BIRCH
AROMATIC RED CEDAR
COTTONWOOD-ELM-HOLLY
SOUTHERN RED GLUM
HICKORY-LAUREL-MAPLE
OREGON MAPLE-PLAIN OAK
- QUARTERED OAK
WYBRODY BENDING OAK
POPLAR-WALNUT



BOXWOOD-EBONY-ROSBARK
JENSEN-ISA-SPANISH CEDAR
LIGHTWYTAE-MAHOGANY
ROSEWOOD-TEAK-RED BEAN
SPOTTED GUM-CASSIA WALNUT

LUMBER-TIMBER
HARDWOOD FLOORING
WYBRODY VENEERED PANELS
DOWELS-TREANAILS-VENEERS

WHITE BROTHERS

FIFTH and BRANNAN STREETS SAN FRANCISCO, CAL.

Our New Trade Mark!



Announcement

WITH the purchase by The Stanley Works of The Stanley Rule and Level Company a new trade mark, as above shown, has been established. In the future it will be stamped upon dependable

*Wrought Steel Hardware
and
Carpenters' Tools*

which will be manufactured under the name

THE STANLEY WORKS

Main offices and Plants: NEW BRITAIN, CONN.

Branch offices:

NEW YORK CHICAGO SAN FRANCISCO LOS ANGELES SEATTLE

We have ready for distribution to architects, an architectural service sheet, AE-1, featuring Storm Sash Hardware which will be mailed on request.



BUILDING BUSINESS

CALIFORNIA'S OLDEST NATIONAL BANK HAS BEEN A VITAL FACTOR IN THE UPBUILDING OF SAN FRANCISCO AND THE ENTIRE WEST.

WHEN LAYING PLANS FOR THE FUTURE OF YOUR BUSINESS CONSULT THE OFFICER OF THIS INSTITUTION

THE FIRST NATIONAL BANK OF SAN FRANCISCO

Affiliated with
FIRST FEDERAL TRUST COMPANY

Combined Resources \$60,473,521.88

The Contractor

Contractor Cannot Submit Plans

The Supreme Court of Oregon has handed down a decision to the effect that contracts let on bids which carry the contractor's own plans and specifications for work on municipal improvements are not valid. This was the case of Montague O'Reilly Company, a corporation, against the town of Milwaukee. The plaintiff brought action to recover damages from the town for its failure to provide a fund to meet the contract price of pavement laid within its corporate limits by the company. The gist of the opinion is that to provide for competition, as the statute requires of all invitations for bids on public work, there must be a fixed standard in the form of established plans and specifications as a means of comparing proposals received.

Eastern Cement Prices Cut

The Lehigh Portland Cement Company, with offices in Allentown, Pa., and ten other cities throughout the United States, recently announced a reduction from 10 to 40 cents per barrel in the price of cement. This company has fifteen mills so located as to be able to serve at least 80 per cent of the Eastern population, and this move therefore is expected to have a far-reaching effect in stimulating immediate activity in all classes of building construction.

Discussing this announcement, an authority on the trade yesterday said:

"Estimates vary as to the sum total of accumulated deferred building of the past two or three years, but it is unquestionably several billions of dollars. As cement enters so largely into all kinds of building construction these days, it is evident that this contribution toward readjustment in price levels will make other industries look around and see

whether they, too, cannot do something toward setting our house in order."

Oakland Builders Organize

An organization, to be named the Builders' Exchange of Alameda County, and to have as one of its purposes arranging arbitration, adjustment and avoidance as far as practical of controversies and misunderstandings which arise between individuals and members engaged in the building and contracting business, has been incorporated. The other purposes of the new corporation are encouragement and protection of building interests, and uniting into one organization of all contractors. The corporation will have no stock. The following are named as directors. Messrs. J. K. Nelson, Robert King, F. D. Parsons, A. K. Goodmundson, Edwin C. Graff, Henry McManus, W. T. Bond, Fred H. Austin, Fred Miller, A. J. Hillam, Albert Jorgensen and B. N. Osborn. All except

TRANSMISSION EQUIPMENT

For Mill or Factory



Pulleys - - Shafting - - - Gears - - -
Hangers - - Bearings - - - Take Ups - -
Sprockets - Clutches - - Chain Belts -
Floor Stands - Belt Tighteners - Rope Sheaves

Meeseco Short Center Drives

Meeseco & Gottfried Company

ENGINEERS AND MANUFACTURERS
CONVEYING, ELEVATING, SCREENING
AND MECHANICAL POWER TRANSMITTING
MACHINERY

SAN FRANCISCO 560 Mission Street SEATTLE 538 First Ave So PORTLAND 67 Front Street LOS ANGELES San Pedro 4 E 3rd St

CANNON & CO.

Clay Products

Denison Interlocking Tile

Face Brick

Hollow Tile

Roof and Floor Tile

San Francisco Office, 1605-6 Chronicle Building

Factory and General Offices:
Sacramento, California

GENERAL BOILERS COMPANY

DEPARTMENT OF SALES

A. W. MERRILL, Manager

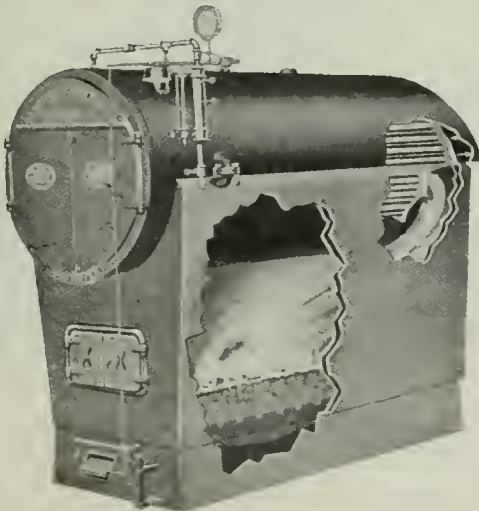

MANUFACTURERS of
Pacific Patented Steel
Portable Double Return Tube
— Low Pressure Steam and
Hot Water Heating Boilers
— Pacific Steel Circulating
Tanks — Pacific Steel Tank
Heaters and Storage Tanks.

General Office and Plant:
WAUKEGAN, ILLS.

Sales Offices: 322 Monadnock Building, San Francisco and 1310 South Hill St.,
Los Angeles, California.



CEMENT GUN

Will Make Your
Concrete Waterproof

Cement Gun Con-
struction Company
of California

701 Balboa Building,
San Francisco

For
DAMS
RESERVOIRS
TUNNELS
BULKHEADS
CANAL
LININGS
CEMENT
FLUMES
use the
Cement Gun
—
SPEED
ECONOMY
PERMANENCE

Jorgensen, who is a resident of Berkeley, are from Oakland.

Youthful Architects

Oakland Technical High School boys and girls who will grow up to be architects, interior decorators and home builders can assign the foundation of their training to construction and designing doll houses. The diminutive kewpie homes are built by students of the household administration classes, and fully equipped. The houses are then turned over when completed to the technical chapter of the Red Cross for sale.

Practical rules of architecture and interior decoration are applied by the instructors in the construction of the homes, who say that the students attain excellent results.

Break in La Jolla Reservoir

A break in the new La Jolla reservoir at the top of Biological grade in San Diego caused the waste of 4,000,000 gals. of water stored in the reservoir. A hole 3 ft. in diameter was found in the concrete side of the reservoir and an earth embankment 55 ft. wide was washed away. The break occurred during the night and was not discovered until the next morning. It is believed the reservoir was dynamited by vandals, as the character of the break does not indicate it was the result of any structural failure.

Annual Report of Oregon State Board of Architects

In the annual report of the Oregon State Board of Architect Examiners, recently filed at the State Capitol, Salem, a suggestion is made whereby smaller cities would be governed in the construction of buildings as is now the case in Portland.

While some of the smaller towns have building codes, they do not protect the public against unsafe buildings from a standpoint of structural safety as well as sanitation.

In the report they suggest the passage of a State building code, with its resultant administrative officers, or providing that buildings be erected from plans and specifications prepared only by registered architects or registered engineers. The report goes on to state:

"The present architects' law states that any person or persons may prepare plans and specifications and erect buildings therefrom, provided they do not use the title architect.

"This safeguards the building public to the extent that persons employing registered architects, are assured that such persons have certain knowledge and skill as provided by law, but does not protect those who, in their ignorance, seek to erect buildings without the services of persons qualified by law, with sometimes disastrous results."

A. H. Bergstrom
Eric Lange

Phone Kearny 3526

LANGE & BERGSTROM

Building Contractors

(Established 1900)

207-210 SHARON BUILDING
San Francisco

TIMKEN BUILDING
San Diego

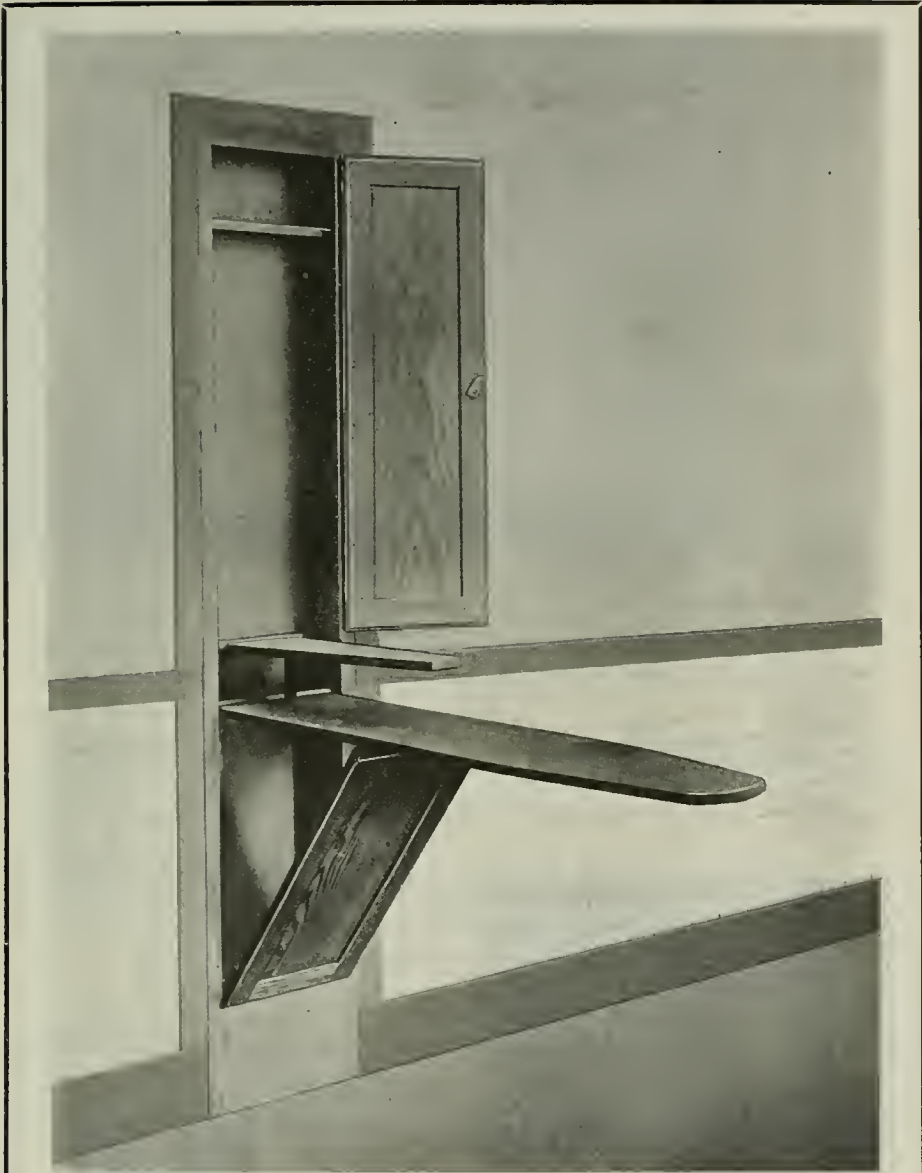

The Peerless Ironing Board

Correctly named, is acknowledged to be the best in points of construction and appearance on the market, and it costs no more than other types.

It fits in an opening between studding, 14 in. by 6-8 (the average door height).

A remarkably rigid fixture, the lower half of the door being used as a brace or support. The upper door may be closed when board is in position. Equipment includes sleeve board.

MANUFACTURED AND SOLD BY

THE HOOSIER STORE

MEZZANINE FLOOR

PACIFIC BUILDING, SAN FRANCISCO

There has been some criticism of the present architect law, according to the report, for the reason that it prohibits landscape architects and naval architects from practicing under their respective titles within the State, without qualifying as architects under the general title.

The members of the board are: Messrs. William C. Knighton, Portland, president; J. E. Wicks, Astoria, vice-president; Morris H. Whitehouse, Portland, treasurer; Lee A. Thomas of Bend, and Frank C. Clarke of Medford. George M. Post is secretary.

Passing of Mr. L. A. Larsen

During the height of festivities at the San Francisco Civic Auditorium December 17th in honor of Mr. Ellis Lewis Garetson, Imperial Potentate of the Mystic Shrine, Mr. Louis Albert Larsen, drum major of the famed "Million Dollar" Islam Temple band, and owner of the Daily Pacific Builder, was stricken with apoplexy and died two hours later.

Mr. Larsen was a member of Islam Temple and of California Commandery No. 1, Knights Templar, to which organization he devoted a great deal of his time. He was a member of the old Knickerbocker quartet, and was possessed of a splendid voice.

Moves to Larger Offices.

One of the handsomest cards of the holiday season received by the Architect

and Engineer was from the McCray Refrigerator Co. of Kendallville, Ind. It came to the editor with the compliments of the San Francisco manager, Mr. G. B. Moore. The McCray company, by the way, has moved its San Francisco sales offices from the Monadnock building to larger quarters at 765 Mission street, where a spacious show room has been fitted up. The old phone number is retained—Douglas 2097.

Opens Los Angeles Branch

The Raymond Granite Co., whose quarries are located at Knowles, Madera County, and whose main offices are in San Francisco, has reopened its Los Angeles finishing plant at 1350-4 Palmetto street under the management of Mr. C. A. Speer. This granite, which possesses a distinctive beauty combined with enduring qualities out of the ordinary, and adaptability for the finest carving, has been used extensively throughout the Pacific Coast. The Raymond company has undertaken a promotion campaign to put its product on a par with the well-known Eastern stones, and is working for an equitable freight rate that will enable it to compete in the Middle West and Eastern markets.

Catalogues Ready

The West Coast Porcelain Manufacturers, makers of high class two-fire vitreous china sanitary ware, announce that

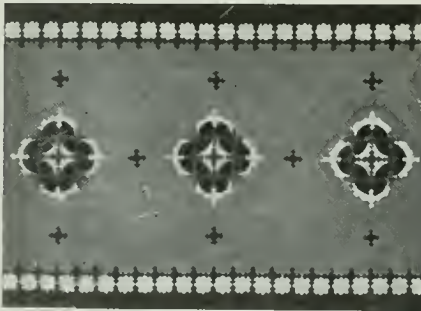

INTERLOCKING RUBBER TILING

material that is sure to give satisfaction. **Twenty tons installed in the Standard Oil Building, San Francisco.** Stock on hand for immediate delivery.

New York Belting and Packing Co.

NEW YORK

San Francisco Branch 519 MISSION ST. Phone Douglas 1837

Small booklet of designs mailed on request.

The Elevator Floor

whether in Office Building, Hotel or Department Store, is subjected to a great deal of wear and tear.

— SPECIFY —

INTERLOCKING RUBBER TILING

and you've provided your client's building with a Durable, Economical, Practical,

material that is sure to give satisfaction. **Twenty tons installed in the Standard Oil Building, San Francisco.**

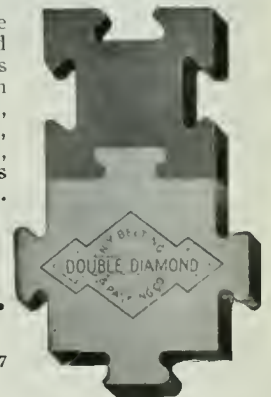

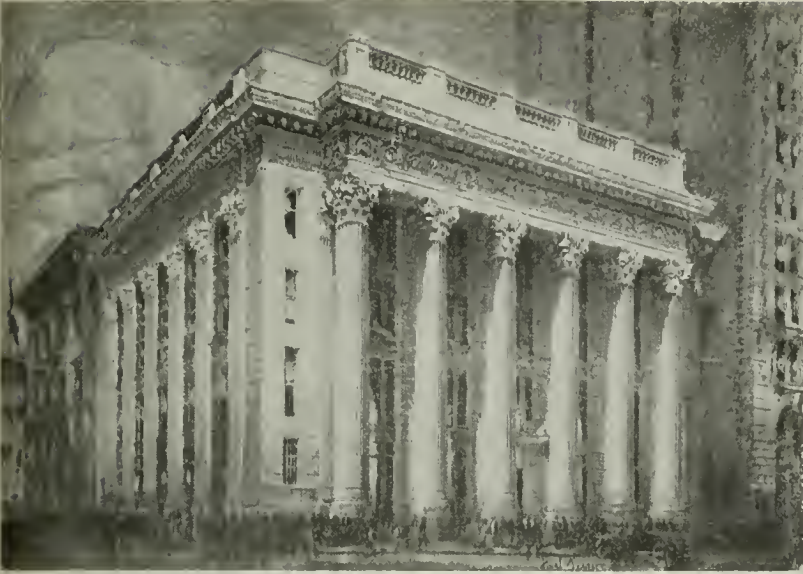

UNITED STATES
NATIONAL BANK
Portland, Ore.
Warm Grey Matt Glazed
Terra Cotta
A. E. Doyle, Architect

Copyright, 1920, by National Terra Cotta Society

Drawing by Hugh Ferriss

BUILDING and BANKING

THE Architect and the Banker are both advisors in investments. The Architect's specification of Terra Cotta is ratified by the Banker not only when it is specified as the material for the bank itself, but for all types of income-producing buildings.

When the Banker, who finances many projects, agrees with the Architect on Terra Cotta, the fact is a significant one for every investor.

The reason underlying the fact is found in the inherent nature of Terra Cotta—*permanent* because it is a resistant of fire, weather and climate; *beautiful* because it is a medium for the expression of the finest architectural design; *profitable* because it not only reduces a building's initial and maintenance cost, but establishes a paying scale of rental.

Bankers, merchants, investors, committee members, and the renting public in general are being told these Terra Cotta facts through the advertising pages of *The Literary Digest*, in a series of unusual advertisements which every architect is earnestly invited to read.

NATIONAL TERRA COTTA SOCIETY is a bureau of service and information. Its publications cover not only the technical and structural use of the material but show, as well, examples of its application to buildings of various types.

Brochures of specific value, as indicated by their titles, will be sent to Architects on request addressed to National Terra Cotta Society, 1 Madison Avenue, New York City.

The School The Theatre The Garage The Store The Bank

These brochures consist of a selection of illustrations, with text and comment, showing Terra Cotta buildings of the respective types.

Terra Cotta—Standard Construction
A Valuable Technical Reference Work for Architects and Engineers.

TERRA COTTA

Permanent Beautiful Profitable

When writing to Advertisers please mention this magazine.



MORRIS PLAN BANK BUILDING, LOS ANGELES
Morgan, Walls & Morgan, Architects

The entire facade is of Grey Mat

Glazed Terra Cotta

Manufactured by

Los Angeles Pressed Brick Co.

FROST BUILDING, LOS ANGELES

UNITED MATERIALS COMPANY

SHARON BUILDING, SAN FRANCISCO

Distributors for Northern California

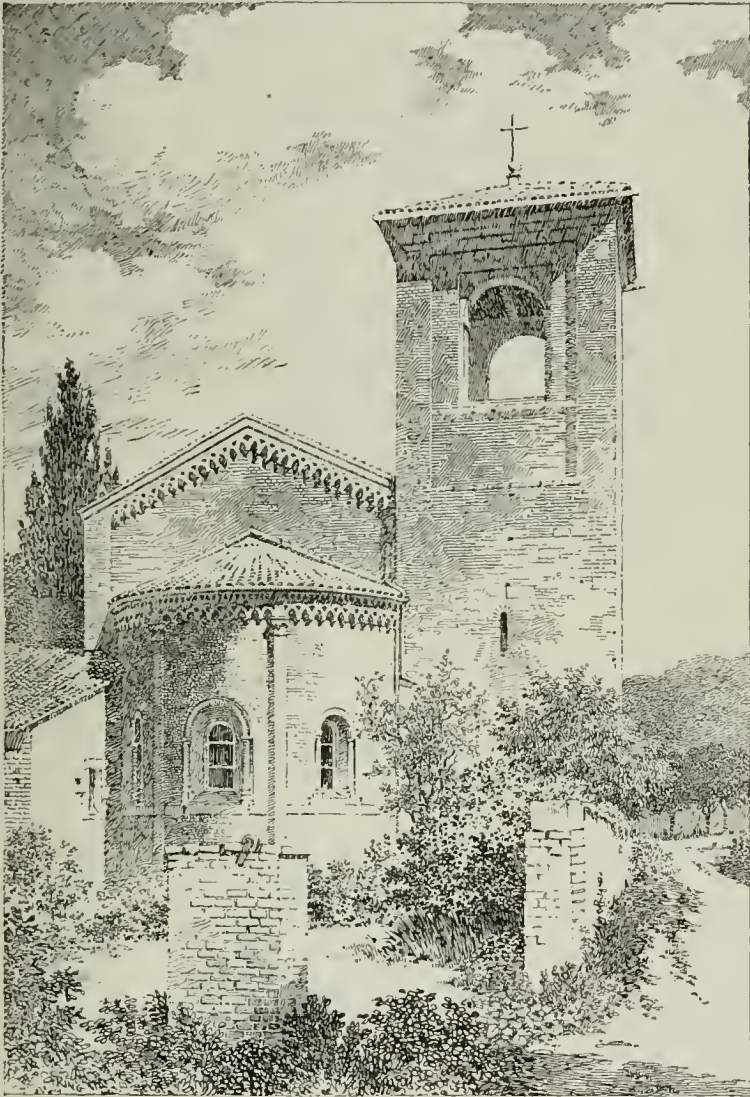

Santa Maria
at Vezzolana, Italy
Built 1189

IN MEDIEVAL EUROPE, following the Crusades, brick architecture enjoyed a remarkable development, as may be seen in this charming Romanesque Italian church of the twelfth century.

Italian ecclesiastical architecture, which has been an inspiration to architects the world over, gives many a convincing proof of the adaptability of brick in church building.

And now, in our time, American face brick

manufacture has added a wealth of color tones and textures to enhance the interest in the wall surface. It has drawn on the whole sweep of color, and has placed in the hands of the architects of this country an almost infinite variety of artistic possibilities.

Any member of this association is at all times ready to discuss the architect's face brick problems with him; and to co-operate with him to the fullest extent.

AMERICAN FACE BRICK ASSOCIATION

1159 WESTMINSTER BUILDING · CHICAGO, ILLINOIS

their new catalogue is ready for distribution. A copy will be mailed on request to architects and others interested. This company is now operating at Millbrae, California, one of the largest porcelain plants on the Coast, specializing in closet tanks and bowls, lavatories, urinals and drinking fountains. The company's main offices are in the Rialto building, San Francisco.

Myers & Schwartz New Distributors for Perfectlite Fixtures

Myers & Schwartz, the well known distributors of Connecticut telephones and Pittsburg reflectors, have recently been appointed distributors in the State of California for the fixtures of the Perfectlite Manufacturing Co. of Seattle, Wash. Suitable show rooms and stock for immediate delivery will be maintained at their stores, 75 New Montgomery street, San Francisco, and 1119 South Los Angeles street, Los Angeles.

Particular attention will be given to the distribution of Perfectlite products, embracing some forty units, to high efficiency lighting for commercial purposes, such as stores, offices, banks, theatres, and in fact every place where efficient and proper lighting is desired.

The Perfectlite lighting fixture line is a coast-made product, well known in this section, having been sold for several years past. The Perfectlite Company feels that in making this new arrangement with Messrs. Myers & Schwartz they will, through the lighting division of the firm, give the trade in general the benefit of the service and knowledge of a competent staff of illuminating specialists whose advice will be of value where installation of Perfectlite Units are considered for correct and efficient lighting.

Prominent Painting Contractor Praises Gold Seal Enamel

On the inside page of the back cover in this issue will be found an interesting letter addressed to the Bass-Hueter Paint Company from D. Zelinsky & Sons, painting contractors of San Francisco. The letter is a splendid indorsement of the Bass-Hueter Paint Company's Gold Seal brand white enamel, which is now being used so extensively and with excellent results by architects and builders throughout the Pacific Coast.

New Berkeley School Damaged by Fire

As if Berkeley had not experienced enough disappointment in the realization of its splendid school building program, by reason of a dormant bond market, fire damaged the only large structure to be completed under the bond issue—the Thousand Oaks school, built at an expense of \$135,000. On January 3 fire starting from a defective flue damaged the

building and equipment to the extent of \$30,000 or more.

Opens Los Angeles Branch

Mr. H. J. Quinn, for the past fourteen years manager of the Oakland branch of the Pacific Manufacturing Company, has been transferred to Los Angeles in charge of the new office there. Mr. Quinn made many friends while in Oakland, who regret his departure yet wish him every success in his new field. The Los Angeles office will be in the Washington building.

The Pacific Manufacturing Company announces that its business policy is constructive and that, while it desires to secure a share of its class of work on large jobs throughout Southern California and Arizona, it has no intention of demoralizing the local market through destructive price cutting, but it seeks business on the basis of quality, service and fair profits.

Mr. Clarence C. Quinn succeeds his brother as manager of the Oakland office, and Mr. J. G. Kennedy, vice-president of the company, becomes manager of the San Francisco office, with Mr. Carl Koenig as his assistant.

Three Pacific Coast Sales Offices for the Stanley Works

With the merger of The Stanley Rule and Level Company and The Stanley Works, both of New Britain, Conn., it became advisable on January 1st to open three new sales offices on the Pacific Coast, as follows:

San Francisco—With Mr. S. V. Armstrong as district sales manager.

Los Angeles—With Mr. L. M. Knouse as district sales manager.

Seattle—With Mr. Bruce Findlay as district sales manager.

These new offices, with the above men as managers, will be very glad to take care of the wants of the hardware trade on the Pacific Coast, both for wrought steel hardware and carpenters' tools manufactured by The Stanley Works.

Plumbers' Strike Ended.

After being on strike for several weeks for an increase of \$2.00 per day to \$12.00, twenty-seven plumbers of Bakersfield and Taft have voted to return to work at the old scale of \$10 per day. The Building Trades Council refused to sanction the strike.

Two Residences

Willis Polk & Company, Hobart building, San Francisco, are designing a \$60,000 house for Mr. Ehrmann to be erected at Washington and Laurel streets and a \$40,000 house at Pebble Beach for Mr. W. W. Crocker, Jr.



The
ST. FRANCIS
 One of the world's great hotels
 Facing Union Square
 SAN FRANCISCO CALIFORNIA

EXPRESSES MOST PLEASANTLY
 THE HOSPITALITY AND ANIMATION
 THAT ARE CHARACTERISTIC
 OF SAN FRANCISCO

Thos. J. Coleman
 Manager

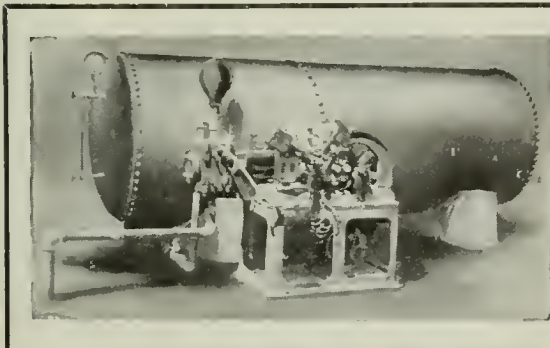

Kewanee Water System

Maintain your own Plant.
 Small Operating Expense.
 A Perfect Water Supply to
 Country Homes, Hotels
 and Parks.

Simonds Machinery Co.

117-121 Montgomery Street
 SAN FRANCISCO
 Phone Kearny 1457

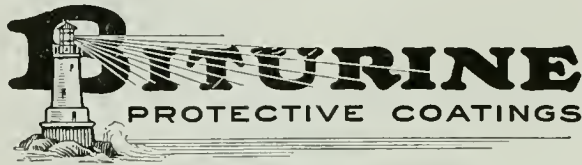

(Anti - Corrosive — Water-proofing)

VULCANITE
Mastic Floors

LINOTOL
Plastic Flooring

Twenty years of manufacturing and contracting experience; let us help solve your problems.

Hill, Hubbell & Company

Manufacturers and Contractors
1 DRUMM STREET, SAN FRANCISCO

LOS ANGELES

SEATTLE

NEW YORK

WaterSavR FLUSHING VALVE

Non-Clogging, Self-Cleaning, Controlling By-Pass

NOTE
Controlling water is in two enclosed chambers B, and separated from the flushing water.

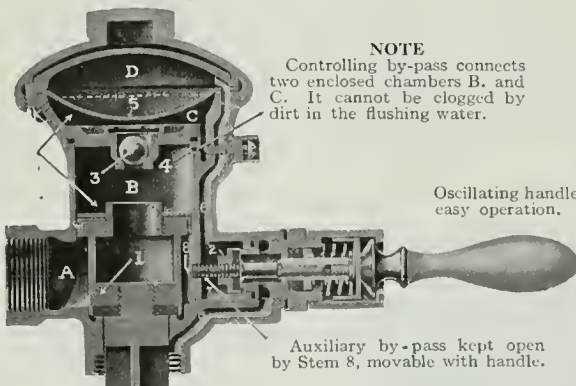

NOTE
Controlling by-pass connects two enclosed chambers B, and C. It cannot be clogged by dirt in the flushing water.

**OPERATES
EQUALLY AS
WELL WITH
DIRTY
AS WITH
CLEAN WATER**

Oscillating handle easy operation.

Auxiliary by-pass kept open by Stem 8, movable with handle.

The by-pass is positively and automatically kept open and free of obstruction and cannot become clogged no matter how dirty the water may be.

Patented March 18, 1919

NATIONAL VALVE COMPANY

Phone Douglas 5093

23-25 MINNA STREET, SAN FRANCISCO

The Heart *of the* Kitchen

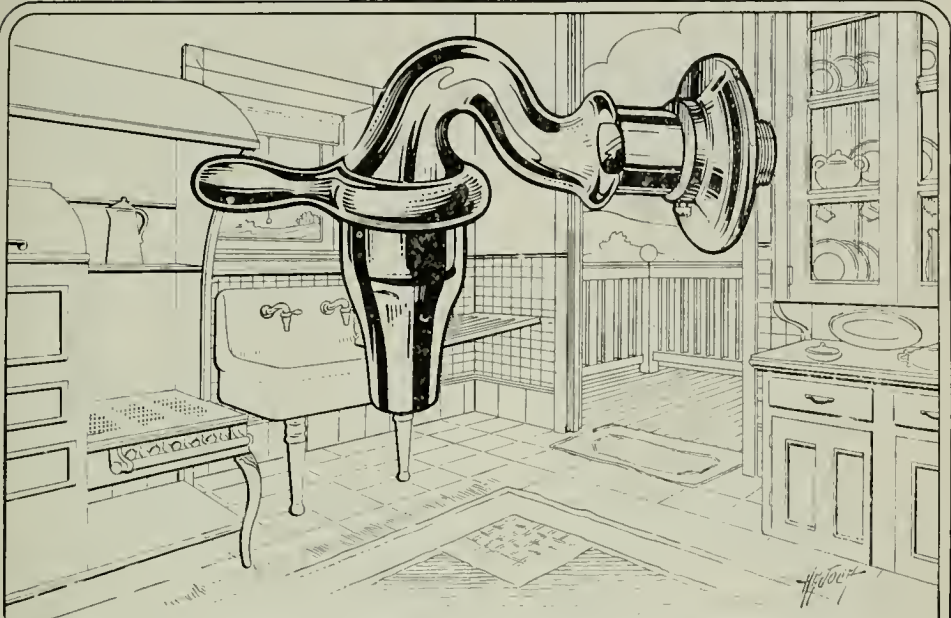

ONE of the most prominent Architect firms in San Francisco, and well known throughout the country, without solicitation on our part, wrote us as follows:

"We not only specify but insist on the plumber furnishing HAJOCA 'Quick' Faucets for all sinks in buildings constructed by us.

We consider everything from the rapid flowing stream to the simplicity of re-washing a delight to the user."

HAJOCA "Quick" Faucets are used not only on kitchen sinks, but shop sinks, laundry trays and factory wash sinks.

Many Architects, like the firm above quoted are standardizing their specifications on HAJOCA "Quick" Faucets.

HAINES, JONES & CADBURY Co.

MAKERS OF PLUMBING SUPPLIES

851 9 FOLSOM STREET, SAN FRANCISCO

PHILADELPHIA-NEW YORK-RICHMOND, VA.-SAVANNAH



WIRING

CONTRACTORS

CENTRAL ELECTRIC
 CO.
 AND DEALERS

135 Stevenson Street, San Francisco
 Phone Douglas 4832

Shop and Compare—that's the
 only true test of values.

Furnishings for the home of distinctive style are featured in this shop at prices that will bear the strictest comparison.

John Breuner Co.
 San Francisco

281 GEARY STREET

Furniture	Draperies
Floor Coverings	Interior Decorations

**Business Systems
 Office Furniture**

F. W. WENTWORTH & CO.
 Distributors for LIBRARY BUREAU
 539 Market Street, San Francisco
 LOS ANGELES OAKLAND SEATTLE

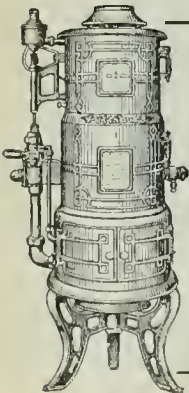

Pittsburg

It Insures
 Instant
 Hot Water
 Service

**PITTSBURG WATER
 HEATER COMPANY**
 478 Sutter St., San Francisco
 Phone Sutter 5025

SERVICE

TESTING
 INSPECTION
 CONSULTATION
 PRODUCTION

Structural and Engineering
 Materials



Robert W. Hunt & Co.
 Engineers

**Chemical and Physical
 Testing Laboratories**

New York	Chicago	Pittsburgh
St. Louis	San Francisco	Mexico City
	London	Montreat



*Residence of W. W. Orcutt, 408 So. Mariposa St., Los Angeles, Calif.,
 H. F. Dierker, Architect.*

**BAY STATE
 Brick and Cement COATING**

A HOUSE takes its place in the front rank of beautiful homes after one or two applications of Bay State Brick and Cement Coating. And it protects as it beautifies. It waterproofs all walls of brick, cement or stucco. Rain can't beat through it. In white, and a large range of delightful tints. Let us send you a sample. Write for Booklet No. 43. It shows many Bay State Coated Homes.

**WADSWORTH, HOWLAND
 & CO., INC.**
 Boston, Mass.

James Hambly & Sons, 268 Market St., San Francisco, Cal., and 447-449 E. Third Street, Los Angeles.

 THE BAY STATER

Present Cost of Building Materials*

With Labor Wage Scale, Bonds, Etc.

THESE quotations are based on reliable information furnished by San Francisco material houses. Date of quotations, January, 1921.
All prices f. o. b. cars San Francisco or Oakland.

American Institute of Architects' Fees

New work—6 per cent minimum basis.
Alterations—7 to 10 per cent as a minimum basis.

High class residence work—10 per cent as a minimum.

Bond—1½% amount of contract.

Brickwork—

Common, \$38.00 per 1000 laid.
Face, \$70.00 per 1000 laid.
Common, f. o. b. cars, \$18.00 plus cartage.
Face, f. o. b. cars, \$45.50 per 1000, carload lots.
12x12x3 in., 10¼c. per square foot.
12x12x4 in., 11¾c. per square foot.
12x12x6 in., 16¼c. per square foot.
Hod carriers, \$8.00 per day.
Bricklayers, \$10.00 per day.
Lime—\$3.25 per bbl.; carload, \$2.75 per bbl.

Composition Floors—30c. per sq. ft.

Concrete Work (material at San Francisco bunkers)—

No. 3 rock.....\$2.50 per yd.
No. 4 rock..... 2.75 per yd.
Niles pea gravel..... 3.25 per yd.
Niles gravel..... 2.50 per yd.
Niles top gravel..... 3.00 per yd.
City gravel..... 2.50 per yd.
River sand..... 1.65 per yd.
Bank sand..... 1.00 per yd.

Monterey White Sand—

Del Monte, \$1.25 to \$1.50 per ton.
Fan Shell Beach, \$2.50 to \$3.00 per ton.
Car lots, f. o. b. Lake Majella.
Cement (f. o. b. cars)....\$4.09 per bbl.
Rebate for sacks, 25c. each.
Atlas "White".....\$9.50 per bbl.
Medusa cement..... 9.50 per bbl.
Forms.....\$60.00 per M

Wage—
Laborers.....\$6.00 per day
Concrete workers..... 7.50 per day
Cement finishers..... 9.00 per day

Dampproofing—

Two-coat work, 30c. per yard.
Membrane waterproofing—4 layers of P. B. saturated felt, \$6.00 per square.
Hot coating work, \$2.00 per square.
WAGE—Roofers, \$9.00 per day.

Electric Wiring—\$8.00 to \$15.00 per outlet (including switches).

WAGE—Electricians, \$9.00 per day. For conduit work, knob and tube average \$4.50 outlet.

Elevators—

Prices vary according to capacity speed and type. Consult elevator companies.

Excavation—

\$2.25 per yard.
Teams, \$12.00 per day.
Trucks, \$30.00 to \$40.00 per day.
Above figures are an average without water. Steam shovel work in large quantities, less; hard material, such as rock, will run considerably more.

Fire Escapes—

Ten-foot balcony, with stairs, \$100.00 per balcony.

*NOTE.—For country work add freight and cartage to prices given.

Glass—(Consult with manufacturers.)

21 ounce, 20c per square foot.
Plate, \$1.75 per square foot.
Art, \$1.00 up per square foot.
Wire (for skylights), 45c. per square foot.
Obscure glass, 30c. per square foot.
Note.—Add extra for setting.
WAGE—Glaziers, \$9.00 per day.

Heating—

Average, \$2.25 per sq. ft. of radiation, according to conditions.
WAGE—Steamfitters, \$10.00 per day.

Iron—

Cost of ornamental iron, cast iron, etc., depends on design.

Lumber—

Common (at building), \$36.00 per 1000 (average).
Common O. P. (select), \$65.00 per 1000 (average).

Flooring—

1x3 No. 1.....	\$87.00 per 1000
1x3 No. 2.....	78.00 per 1000
1x4 No. 1.....	84.00 per 1000
1x4 No. 2.....	81.00 per 1000
1x4 No. 3.....	74.00 per 1000
1x6 No. 1.....	85.00 per 1000
1x6 No. 2.....	92.00 per 1000
1¼x4 and 6 No. 1.....	90.00 per 1000
1¼x4 and 6 No. 2.....	89.00 per 1000
Slash grain, 1x4 No. 2.....	71.00 per 1000
Slash grain, 1x4 No. 3.....	55.00 per 1000
No. 1 common run to	
T. & G.....	54.00 per 1000
Lath.....	7.50 per 1000

Shingles—

Redwood, No. 1.....\$1.20 per bdle.
No. 2..... 1.10 per bdle.
Red cedar..... 1.30 per bdle.
(Add cartage to above)

Hardwood Floors—

Maple floor (laid and finished), 30c per foot.
Factory grade floors (laid and finished), 23c per foot.
Oak (quartered, finished), 65c. per foot.
¾ Oak (clear), 39c per foot (plain).
¾ Oak (select), 37c. per foot (plain).
¾ Oak, quartered, sawed, clear, 45c.
WAGE—Floor layers, \$10.00 per day.

In flooring the usual grades of oak used are

	Grades	Quartered	Plain
		Sawed	Sawed
5/16".....	Clear	45	39
	Select	41	37
1"x3"-13/16"x2¼".....	Clear	65	50
	Select	55	45
	No. 1 (very little used)		

Hardwood Floors (not laid)— Per M ft.

5/16x2" sq. edge	Clear quartered oak.....	\$245.00
	Select quartered oak.....	207.00
	Clear Plain oak.....	150.00
	Select plain oak.....	125.00

THE ARCHITECT AND ENGINEER

Hardwood Floors (not laid)—Continued

	Per M ft.
13/16x3 1/4" face Clear quartered oak.....	\$290.00
Select quartered oak.....	200.00
Clear plain oak.....	200.00
Select plain oak.....	175.00
Clear maple.....	177.50
Clear maple—white.....	250.00
13/16x3 1/4" face Clear maple.....	177.50
1 1/8x2 1/4" face Clear maple.....	177.50
1 1/8x2" face Clear quartered oak.....	215.00
Select quartered oak.....	160.00
Clear plain oak.....	150.00
Select plain oak.....	130.00
Clear maple.....	122.50

Millwork—

O. P., \$150 per 1000. R. W., \$140 per 1000.	
Double hung box frame windows (average) with trim.....	\$9.50 each
Doors, includ. trim (single panel).....	\$13.50 each
Doors, including trim (five panel).....	\$11.00 each
Screen doors.....	5.00 each
Window screens.....	3.50 each
Medicine cases.....	5.00 each
Cases for kitchen pantries seven feet high, per lineal foot.....	7.50 each
Dining room cases same price, if not too elaborate... ..	7.50 each
Flag poles, per foot.....	1.50

Labor—Rough carpentry, warehouse heavy framing, \$13.00 per 1000.
For smaller work, average, \$21.00 to \$28.00 per 1000.
WAGE—Laborers, \$6.50 per day.
Carpenters, \$9.00 per day.

Marble—(Not set) add 60c up per ft. for setting

Columbia.....	\$2.05 sq. ft.
Alaska.....	2.05 sq. ft.
San Saba.....	3.65 sq. ft.
Tennessee.....	2.50 sq. ft.
Verde Antique.....	4.55 sq. ft.

Painting—

Two-coat work, 42c. per yard.
Three-coat work, 55c per yard.
Whitewashing, 6c per yard.
Cold water paint, 10c. per yard.
Turpentine, \$1.32 per gal. in cases and \$1.17 per gal in tanks.
Pioneer white and red lead, 11 3/4c lb. in one ton purchases; 12 1/2c lb. for less than 500 lbs.
WAGE—Painters, \$8.50 per day.
NOTE—Accessibility and conditions cause wide variance of costs.

Patent Chimneys—

6-inch.....	\$1.50 lineal foot
8-inch.....	1.75 lineal foot
10-inch.....	2.25 lineal foot
12-inch.....	3.00 lineal foot

Pipe Casings—\$8.00 each.

Plastering—

Interior, on wood lath, 75c per yard.
Interior, on metal lath, \$1.40 per yard.
Exterior, on brick or concrete, \$1.35 per yard.
Portland White, \$1.75 to \$2.00.
Interior on brick or terra cotta, 60c to 70c per yard.
Exterior, on metal lath, \$2.25 to \$2.75 per yard.
Wood lath, \$8.00 at yard per 1000.
Metal studding, \$1.25 to \$1.50 per yard.
Metal studding, with lath and plaster,

\$2.15 per yard.
Galv. (metal lath), 38c. and up per yard, according to gauge.
Lime, f. o. b. warehouse, \$3.25 per bbl.
Hardwall plaster, \$24.00 per ton, f. o. b. warehouse.
WAGE—Hod carriers \$9.00 per day.
Plasterers, \$11.00 per day.

Plumbing—

From \$70.00 per fixture up, according to grade, quantity and runs.
WAGE—Plumbers, \$10.00 per day.

Reinforcing Steel—

Base price for less than car load lots, \$5.75 per 100 lbs.
Car load lots, \$5.50 per 100 lbs., f. o. b. San Francisco. (Mill delivery.)

Roofing—

Five-ply tar and gravel, \$7.50 per square for 30 squares or over.
Less than 30 squares, \$8.00 per square.
Tile, \$35.00 per square.
Redwood shingle, \$13.00 per sq. in place.
Cedar shingle, \$13.00 per square in place.
Reinforced Pacbo roofing, \$8.25 per square. WAGE—Roofers, \$9.00 per day.

Rough Hardware—

Nails, per keg, \$7.00 base and very scarce.
Deafening felt, \$170.00 per ton.
Building paper, P. & B.,
1 ply, \$6.50 per 1000 ft. roll.
2 ply, \$9.75 per 1000 ft. roll.
3 ply, \$14.00 per 1000 ft. roll.
Sash cord,
(Sampson spot), \$3.00 per hank 100 ft.
Common, \$1.75 per hank 100 feet.
Sash weights, cast iron, \$80.00 per ton.

Sheet Metal—

Windows—Metal, \$2.00 a square foot.

Skylights—

Copper, \$1.25 a square foot (not glazed).
Galvanized iron, 40c a square foot (not glazed).
WAGE—Sheet metal workers, \$10.00 per day.

Store Fronts—

Kawneer copper bars for store fronts.
Corner, center and around sides, will average \$1.35 per lin. foot.
Zouri bar, \$1.25 per lin. foot.
Zouri Underwriters' Specification sash, \$1.60 per lin. foot.

Structural Steel—\$140.00 per ton.

This quotation is an average for comparatively small quantities.
Light truss work higher; plain beam and column work in large quantities, less.

Steel Sash—

Fenestra, from S. F. stock, 45c. per sq. ft.
Fenestra, Plant shipment, 40 1/2c. per sq. ft. (Includes mullions and hardware.)
Trus-con, from San Francisco stock, 40c to 45c per sq. ft.
Trus-con, plant shipment, 35c to 42c per sq. ft.
U. S. Metal Products Co., 40c per sq. ft. in San Francisco.

Tile—

White glazed, 80c. per foot.
White floor, 80c. per foot.
Colored floor tile, \$1.00 per foot.
Promenade tile, \$1.00 per sq. foot, laid.
WAGE—Tilers, \$9.00 per day.

ARMCO IRON



Window Frames and Other Galvanized Metal Building Products

WHEN you build, *build for permanence.* Use Armco Iron for all galvanized parts—roofing, coping, cornices, gutters, pent-houses, skylights, water-tanks, ventilators, conductor pipes, window frames and sashes. Armco Iron (galvanized) has been employed extensively in various building operations which have recently been started or completed. For instance, in the Railway Exchange Building, St. Louis, more than one million pounds of Armco Iron are used in the window frames.

Because of its purity, evenness and freedom from imprisoned gases, Armco (Ameri-

can Ingot) Iron takes and holds a purer and more lasting galvanizing coat than any other metal. So securely is the galvanizing fused with the base metal (Armco Iron), that it will not crack, scale or peel off. Leading architects specify Armco Iron, builders use it, sheet-metal workers endorse it, and property owners and investors sanction it for every kind of building, new or altered—residential, industrial, school, church, public or office.

Look for the Blue Triangle when purchasing Armco Iron Sheets.



The trade mark ARMCO iron bearing that mark is manufactured by The American Rolling Mill Company with the skill, intelligence and fidelity associated with its products, and hence can be depended upon to possess in the highest degree the merit claimed for it.

THE AMERICAN ROLLING MILL COMPANY MIDDLETOWN, OHIO

*Licensed Manufacturers under Patents granted to the
International Metal Products Company*

Pacific Coast Sales Office — 10th & Bryant Streets, San Francisco,
other Branch Offices in New York, Chicago, Pittsburgh, Cleveland,
Detroit, St. Louis, Cincinnati, Atlanta, Washington, D. C. and Buffalo

AN AMPLE STOCK CARRIED AT SAN FRANCISCO

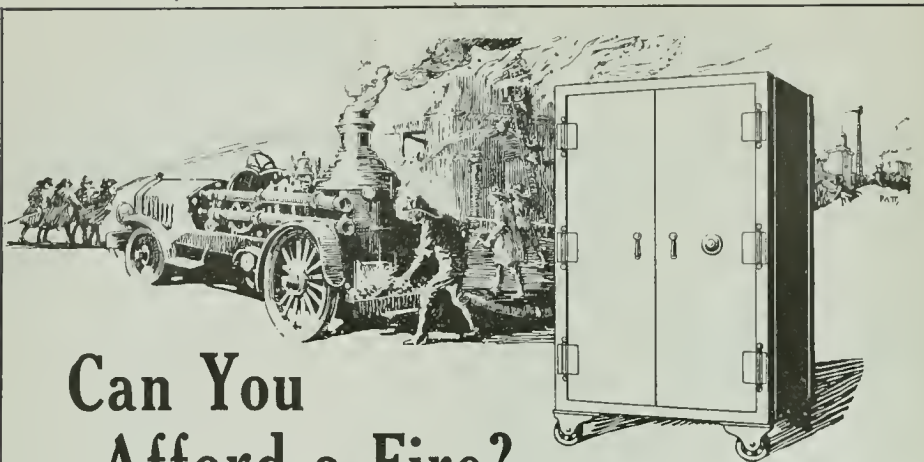

Can You Afford a Fire?

A "Safe First" Story

ROADES had made good headway and was accredited with something more than the average business acumen. He was cautious, moreover, and — as he thought — had fully protected the business with ample fire insurance.

But like many careful business men, he had overlooked the most important thing of all. No insurance written could ever make up for the loss of certain of his business records and data. Many of them were absolutely irreplaceable.

And yet, down in the wooden filing case of H. B. Roades & Company, there lay exposed the vital records of their hard earned development, the most important documents the firm possessed.

One night Roades received this message over the wire from his partner: "The offices are on fire. *Hurry!*"

Of course he was too late, then. The documents were destroyed.

The past two years have gone hard with Roades. In addition to costly and extended litigation, he has had to bear the expense of gathering an entirely new set of records — all because his office had lacked a good steel safe.

Finally established in another office, he approached H. S. Crocker Company

to make sure that his records would be given every protection in the future. Now, he wanted a good "catastrophe proof" safe.

The burglar and fire-proof specifications of the Globe-Wernicke Steel Safe, the Underwriters' Label guarantee — combined with Roades' own painful experience obviated the need of any salesman's persuasion. All that was required of us was to point out the particular size and type best suited to his particular business.

Roades protected his business after he had let himself be cleaned out — but like you, he could have forestalled all this.

You cannot afford a fire. A relatively small investment will bring you a safe first. Why not consult Crocker today by phone or call?

H. S. CROCKER CO., INC.

565-571 Market Street, San Francisco

Los Angeles

1444 Broadway, Oakland

Sacramento

SONNEBORN PRODUCTS

Grind-Proof *and* Dust-Free Concrete Floors!

DUSTING WEARING CONCRETE FLOORS
ARE A THING OF THE PAST WHEREVER
ARCHITECTS HAVE SPECIFIED

Lapidolith

THIS liquid chemical has been flushed on 70,000,000 square feet of concrete floors old and new during the last two years alone. These lapidolized floors are now wearproof and dust-proof, because Lapidolith has completed the hydration of the Portland Cement and this Concrete is harder than granite.

Have you seen the results secured by the Lapidolith treatment? If not, let us refer you to a lapidolized floor near you. Thereafter you will specify Lapidolith on your old and new concrete work.

SONNEBORN PRODUCTS:

Cemcoat

the durable Mill White, Washable, of exceptional covering capacity, Gloss, Flat and Egg-shell, also all colors.

Lignophol

the modern wood preservative gives new life to old or new wooden floors.

Write for sample, literature and specification form

*Concrete for Permanence
Lapidolith for Dustlessness*

L. SONNEBORN SONS, Inc.

San Francisco

Los Angeles

Seattle

SONNEBORN

ZOURI**SAFETY SASH BARS**

Accepted by the Insurance Underwriters for Safety Setting of Plate Glass used in Store Front Construction.

COBBLEDICK-KIBBE GLASS CO.175 JESSIE ST. WASHINGTON AT THIRD ST.
SAN FRANCISCO, CAL. OAKLAND, CAL.**POWER CONSTRUCTION CO.**

INCORPORATED

CONTRACTING ENGINEERSPreliminary Estimates Given in All Types
of Buildings, Towers and BridgesSHARON BUILDING, SAN FRANCISCO
Phone Sutter 5478**CHAS. STOCKHOLM & SONS****GENERAL CONTRACTORS**

849 MONADNOCK BUILDING Phone DOUGLAS 4657 SAN FRANCISCO

John Ringius Company, Inc.

MANUFACTURERS OF

Multivane Volume Fans and Steel Plate Blowers made to order,
any size, for Heating and Ventilating Plants in Theatres,
Schools, Public Buildings, Etc.**Sheet Metal Products****Fans and Blowers**

330 Ritch Street

SAN FRANCISCO

Phone Garfield 1108

JOHN M. BARTLETT**GENERAL CONTRACTOR**Office
357 - 12th ST., OAKLANDPhone Lakeside 6750
Res. Phone Berkeley 6884W**E. T. LEITER & SONS****BUILDING CONSTRUCTION**

412 CALL-POST BUILDING Phone SUTTER 1980 SAN FRANCISCO

CHAS. G. FRIES.

TELEPHONE SUTTER 5706

VICTOR A. KUEHN

LIBERTY ELECTRIC COMPANY

479 Sutter St. Electrical Contractors San Francisco, Cal.

SAMSON SPOT SASH CORD

SPOT IT BY THE SPOTS

Made of extra quality cotton yarn, firmly braided and smoothly finished. Carefully inspected and guaranteed free from all imperfections of braid and finish. → Can be distinguished at a glance by our trade-mark, the Colored Spots. Send for catalogue and samples.

Pacific Coast Agent, JOHN T. ROWNTREE, Inc., San Francisco and Los Angeles, Cal.

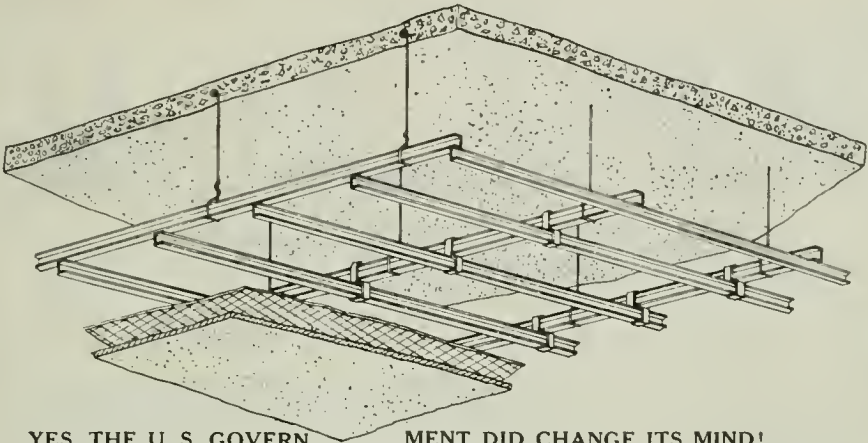

YES, THE U. S. GOVERNMENT DID CHANGE ITS MIND!

The specifications on the U. S. Government Building at Portland, Oregon, called for the tying together of the carrying bar and lathing bar with wire.

We submitted our system, and after an explanation of the S. S. System for fastening bars, the engineers and government officials were convinced that here, at last, is the perfect and economical system, and these reasons added weight in deciding.

It is a positive tie, no slipping or shearing.

It is strong, Smith Emery test to 353 lbs. before failing.

It is fast, can be applied on the bench or on the scaffold.

Made for 1 inch carrying bar and 3/4 inch lathing bar and 3/4 inch carrying bar and 3/4 inch lathing bar. Can be used for wall furring as well as for ceiling work.

THE STEEL STUDDING COMPANY

Also Manufacturers of

THE PRONG CHANNEL FOR SOLID AND HOLLOW PARTITIONS

Agents Wanted Everywhere

1216 Folsom Street, San Francisco

A TEN YEAR GUARANTEE

is back of this roof covering and it **costs less** than other roofing materials



2400 gallons used on the Fairmont Hotel, San Francisco.

Bekin's Warehouse is waterproofed with it.

The W. O. W. Building, Oakland, is roofed with it.

You make no mistake when you specify

LIQUID ASBESTOS PATCH-HOLE CEMENT

Write for sample and price list.

California Plastic Products Company

521 SHELDON BUILDING, SAN FRANCISCO, CALIFORNIA

**FOR MODERN
STORE FRONTS**

Plummer's Disappearing Awnings

Are constructed with no outside attachments below awning recess. All mechanical parts entirely concealed. Send for Architects' Sheet showing specifications for recess construction, etc.

W. A. PLUMMER MFG. CO., 35-37 Front Street, San Francisco

JOHN TRAYNOR

CHARLES HARCOURT

OCEAN SHORE IRON WORKS

Manufacturers of Oil Tanks, Water Tanks, Pressure Tanks, Air Receivers, Feed Water Heaters, Breechings, Smoke Stacks, Water Pipe, Boilers, Retorts, Digestors, Pneumatic Pressure Tanks, Riveted or Oxy-Acetylene Welded Tanks, and dealers in Boilers, Tanks, Pumps, Engines, Machinery, Steel Plates, Shapes

Special Attention Given to Government and Export Orders

OCEAN SHORE IRON WORKS

Office and Works: 550-558 EIGHTH STREET, SAN FRANCISCO, CAL.

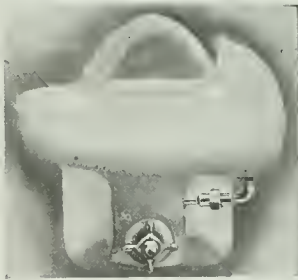

Model No. 7A.

NO GERMS HERE

HAWS IMPROVED SANITARY DRINKING FAUCET eliminates all possibility of contracting disease from dirty bulbs or unsanitary bowls. Provided with an overhead cowl, the drinker's lips never touch the source of supply. A slanting stream throws the water from right to left and away from the bubbler, instead of straight up to fall back over the fountain head. Recommended for Schools and Public Playgrounds. A type used extensively by the U. S. Government. Manufactured by

Haws Sanitary Drinking Faucet Co., Inc.
1808 Harmon Street, Berkeley Phone Piedmont 3742

GLADDING, McBEAN & CO.

MANUFACTURERS CLAY PRODUCTS

CROCKER BUILDING, SAN FRANCISCO

WORKS, LINCOLN, CAL.

WILSON

2800 ROLLING STEEL DOOR

Chain Gear Operation

Standard for 45 years

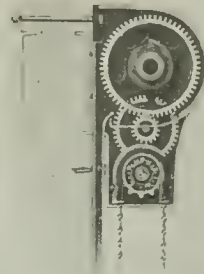
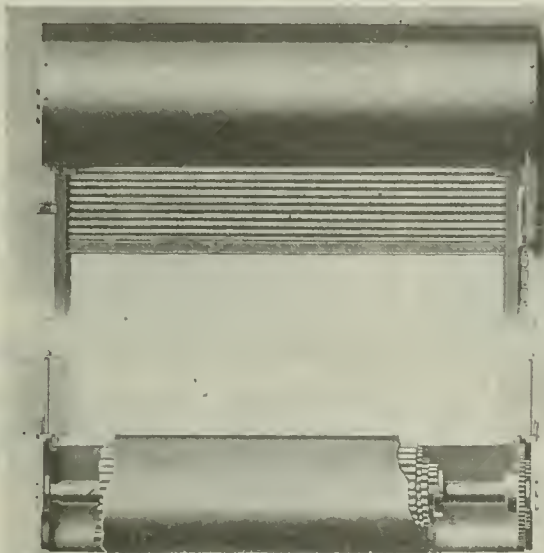

WILSON 2800
One of our
Standard
Designs

Coil placed on face of wall above Lintel with Grooves on face of Wall. "Big 4 Slats."

Adapted to openings 3x10 up to 20x25. Especially suitable for freight sheds, piers, driveways, etc.

Gearing protected from the weather insuring efficient operation. Openings over 14 feet wide may be fitted with safety grooves.

THE J. G. WILSON CORPORATION

Manufacturers of

Diffuselite Blinds and Awnings, Rolling Partitions, Rolling Steel Doors, Folding Partitions, School Wardrobes, Folding Casements

Pacific Coast Office and Exhibit:

600 Metropolitan Bldg. ·Phones: 60871; Bdy. 502, Los Angeles, Calif.

Waterhouse-Wilcox Co., San Francisco; Theo. F. Snyder, San Diego; F. W. Farrington & Co., Portland; F. W. Farrington & Co., Seattle; Hawley-Richardson-Williams Co., Salt Lake City; Walter Durbree, Phoenix.

THE TORMEY CO.

General
Painters

Phone Franklin
5-5-9-8

1042 Larkin St., San Francisco, Cal.

Alvaline, Cementoline

and other

Jones-Duncan Products

MAGNER BROTHERS
PAINT MAKERS

Telephone: Market 113
414-424 Ninth St. San Francisco

HEATING=PLUMBING

COMPLETE PLUMBING AND
HEATING SYSTEMS INSTALLED
IN ALL CLASSES OF BUILDINGS
ALSO POWER PLANTS

GILLEY-SCHMID CO., Inc.

198 OTIS STREET, SAN FRANCISCO.
Tel. MARKET 965

"BLAZING" THE TRAIL

We've been doing it for many years—giving the Sportsman Better Value for Quality than he ever before received. "Value at a Fair Price" in everything for the Sportsman.

The
Ellery Arms
Company

583-85 MARKET ST
SAN FRANCISCO, CAL

SEND FOR CATALOG *The Sign of Quality*

Phone Douglas 3224

Hunter & Hudson
ENGINEERS

Designers of Heating, Ventilating
and Wiring Systems. Mechanical
and Electrical Equipment of
Buildings.

703 Rialto Bldg., San Francisco, Cal.

**BEAVER BLACKBOARD
BEAVER GREENBOARD**

SCHOOL FURNITURE
AND SUPPLIES—
OFFICE, BANK AND
COURTHOUSE FURNITURE—
THEATRE AND
AUDITORIUM SEATING

Rucker-Fuller Desk Co.

677 Mission St., SAN FRANCISCO, CAL.
434 Higgins Bldg., LOS ANGELES, CAL.
432 - 14th Street - OAKLAND, CAL.

ELECTRICAL MECHANICAL

BALDWIN DREW WARD

Consulting Engineer
Power and Industrial Plants

Associate Member A. I. E. E.

76 Eleventh St. Oakland, Cal.

RUSSWIN

BUILDERS' HARDWARE

JOOST BROS., Inc.

SAN FRANCISCO AGENTS.

We Carry Complete Stock:

Fishing Tackle—Guns—Mechanics' Tools—
Paints—Crockery and Glassware—Stoves—
Household Goods. Telephone Market 891.

NO BRANCH STORE

Mazda Lamps Electric Goods

Your Client, Mr. Architect Demands

Snow White Brilliance

Upon a Smooth Surface

☞ Petrium Sanitary Sinks answer every requirement. They are non-porous, non-absorbent and lye-proof. There are no crevices or corners to catch the dirt and grease. ☞ Therefore Specify this sink.

☞ Can be installed in any home or apartment — new or old. A California product.

Send for our Booklet and Price List

**Petrium Sanitary Sink
Company**

Factory and Office, West Berkeley



PORTAL Economy Plan Service and PORTAL Quality Wall Beds

PORTAL wall-beds have received Highest Award wherever exhibited—an evidence of quality that should interest the Builder.

Patented oscillating arm permits the "Portal" bed to revolve in a foot less space than any other revolving bed—a good point to remember.



See
Show Rooms
in the
Phelan
Building

MARSHALL & STEARNS CO.

1152 Phelan Bldg.,
1774 Broadway,

San Francisco
Oakland

When writing to Advertisers please mention this magazine.

A. D. COLLMAN	P. F. SPEIDEL
COLLMAN AND SPEIDEL	
GENERAL CONTRACTING	CONSTRUCTION ENGINEERS
Telephone SUTTER 4858	MONADNOCK BUILDING, SAN FRANCISCO

Phone Franklin 548
I. R. KISSEL
<i>Decorator, Painter and Paperhanger</i>
1747 SACRAMENTO ST., Bet. Polk St. and Van Ness Ave., SAN FRANCISCO

PHONE MISSION 2209	
ROBERT TROST	
General Building Contractor	
We Specialize in High Grade Work and Employ Skilled Labor in every Branch of the Building Industry.	26th and Howard Streets SAN FRANCISCO

P. A. Palmer	Peter Petersen	W. L. Kelly
PALMER & PETERSEN		
Contracting Engineers		
782-796 Monadnock Building	SAN FRANCISCO, CAL.	

S. RASORI, RES. 2042 TAYLOR ST. PHONE FRANKLIN 6258	J. DEL FAVERO, RES. 1839 MASON ST. PHONE FRANKLIN 9524
DEL FAVERO & RASORI	
GENERAL CONTRACTORS	
MEMBERS OF THE S. F. BUILDERS EXCHANGE AND THE BUILDING INDUSTRIES ASS'N	
OFFICE: 110 JESSIE STREET	SAN FRANCISCO, CALIF.

MONSON BROS.	
GENERAL CONTRACTORS	
Telephone Market 2693	1908 Bryant Street, San Francisco

UNIT CONSTRUCTION COMPANY	
(INCORPORATED)	
ENGINEERING AND CONSTRUCTION	
Telephone Kearny 28	429-36 Phelan Building, SAN FRANCISCO

J. D. HANNAH	
Contractor and Builder	
OFFICE: 142 Sansome Street San Francisco, Cal.	Telephone Douglas 3895 BUILDERS EXCHANGE, 180 JESSIE STREET

**MOUNT DIABLO CEMENT
COWELL SANTA CRUZ LIME**

ALL KINDS OF

BUILDING MATERIALS

HENRY COWELL LIME AND CEMENT CO.

Phone Kearny 2095

No. 2 MARKET STREET, SAN FRANCISCO

Automatic Fire Sprinklers

Protect your building and business from destruction by fire and reduce your Insurance Rate.

Pacific Fire Extinguisher Co.

FIRE PROTECTION ENGINEERS

424-440 HOWARD STREET
SAN FRANCISCO

MANUFACTURING PLANT
272 STEUART STREET

LINOTILE

“The Floor that’s Built to Fit the Room”

Furnished and Laid by

VAN FLEET-FREEAR CO.

Telephone :
Douglas 1227

61 New Montgomery Street
San Francisco, California

Kawneer

Factory
Berkeley, Calif.
Berkeley 8710

MANUFACTURING COMPANY
of California

San Francisco Office :
180 Jessie Street
Sutter 6700

Kawneer
Store-Fronts
All Metal Mouldings

Kawneer
Simplex Windows
Weightless & Reversible

I. M. SOMMER,**CONTRACTOR & ENGINEER**

Phone Kearny 4582

401 BALBOA BLDG., SAN FRANCISCO

K. E. PARKER COMPANY, Inc.**GENERAL CONTRACTORS**

Phone Sutter 5661

Room 515 Clunie Building, SAN FRANCISCO

R. W. LITTLEFIELD
BUILDING CONSTRUCTION

357 12th Street, Room 9, Oakland, Cal.

Phone Lakeside 6750

H. H. HILP, Jr.

J. FRANK BARRETT

BARRETT & HILP**CONCRETE CONSTRUCTION BUILDERS GENERAL CONTRACTORS**

SHARON BUILDING, SAN FRANCISCO

TELEPHONE SUTTER 1168 or 1169

Res. Phone Mission 5049

JAMES F. SMITH — Plasterer

273 Minna Street, San Francisco

Phone KEARNY 740

Member Builders Exchange

STEELFORMS Signify ECONOMY, RAPIDITY, and EFFICIENCY

STEELFORM CONTRACTING COMPANYSTEELFORMS FOR
CONCRETE
BUILDINGS

C. B. Hopkins, C. E., Manager

681 Market Street, San Francisco

CONCRETE JOIST
FLOOR
CONSTRUCTION**W. C. DUNCAN & CO.**

508 Sharon Bldg.

General Contractors

San Francisco

M. E. VUKICEVICH

SPENCER B. BAGGE

VUKICEVICH & BAGGE
GENERAL CONTRACTORS

Phone Sutter 6700

Office, Builders Exchange, 180 Jessie St., San Francisco

245 Market St. **Standard Fence Co.** 310 Twelfth St.
 S. F. Kearny 2028 **WIRE AND IRON WORKS** Oakland 475

DESIGNERS - BUILDERS
 FACTORY PROTECTION FENCE
 AVIARY AND TENNIS COURT FENCE
 320 North Los Angeles Street, Los Angeles, Cal. Phone 67188

WIRE GRILL WORK—WIRE SCREEN
 FLEXIBLE WIRE CONVEYOR BELT
 WIRE SPECIALTIES

Steel Bars FOR CONCRETE REINFORCEMENT
 Cut to Length, Fabricated, Installed

BADT-FALK & CO.

Tel. Douglas 3466 346 Call-Post Bldg., 74 New Montgomery St., San Francisco

BUILDING DIRECTORIES [INTERCHANGEABLE STEEL
 LETTERS AND NUMBERS]

FOR OFFICE BUILDINGS, SCHOOLS, CAFETERIAS, Etc.
 Bargains Lists for Auto Sales Companies. Sold Outright.

Go-Sign and Letter Manufacturing Co.

1106 Franklin Street Oakland, California

D. N. & E. WALTER & CO.
 "SINCE 1858"

LINOLEUMS—CARPETS LARGE STOCKS CARRIED
 Estimates furnished on request

562-572 MISSION STREET SAN FRANCISCO

Phone Merritt 668

H. N. McNAB

Hardwood Floors  Floor Sanding

2307 - 17th Ave. Oakland, Cal.

Res. Tel. Merritt 3600

HERBERT BECKWITH
Building Construction

Formerly with ARTHUR ARLETT 323 Newton Ave.
 Oakland

D. ZELINSKY & SONS
 PAINTERS AND DECORATORS

420 TURK STREET, SAN FRANCISCO

CHARLES T. PHILLIPS
CONSULTING ENGINEER

PACIFIC BUILDING SAN FRANCISCO
 HEATING VENTILATION WIRING ILLUMINATION

Ideal Air-Washers. Ideal Fruit-Dryers. Fan Systems for Heating, Cooling and Drying.

Ideal Heating and Engineering Co.

Air-Conditioning, Heating, Cooling and Drying

192 ERIE STREET

Phone Market 3708

SAN FRANCISCO

Atlas Heating and Ventilating Co., Inc.

ENGINEERS and CONTRACTORS

STEAM AND HOT WATER HEATING, FANS, BLOWERS,
FURNACES, POWER PLANTS--SHEET METAL WORK

Phone Douglas 378

Fourth and Freelon Sts., Bet. Bryant & Brannan, SAN FRANCISCO

Illinois Automatic Vacuum and Vapor Systems of Heating

"TWENTY-FIVE YEARS OF QUALITY"

ILLINOIS ENGINEERING COMPANY

JAS. I. KRUEGER, *Representative*

559-561 Pacific Building, San Francisco

Telephone: Kearny 3047

HEATING
VENTILATION

FLOOR AND WALL TILING

PLUMBING
SHEET METAL WORK

SCOTT CO., Inc.

SUCCESSOR TO JOHN G. SUTTON CO.

243 MINNA STREET

SAN FRANCISCO

ALEX COLEMAN

CONTRACTING PLUMBER

706 ELLIS ST., SAN FRANCISCO

Phone FRANKLIN 1006

WM. F. WILSON COMPANY

MODERN SANITARY APPLIANCES

Special Systems of Plumbing for Residences, Hotels, Schools, Colleges, Office Buildings, Etc.

Phone Sutter 357

328-330 Mason Street, San Francisco.

C. DRUCKER

J. C. JAMES

JAMES & DRUCKER

Plumbing—Heating Contractors

Phone Market 275

450 Hayes Street, San Francisco, Cal.

The Granite Work on Eldorado County Courthouse; National Bank of D. O. Mills, Sacramento;—
and Sen. Nixon Mausoleum, Reno, WAS FURNISHED BY

CALIFORNIA GRANITE COMPANY

Phone Sutter 2646

STONE CONTRACTORS

Builders' Exchange, San Francisco
Quarries, Rocklin and Porterville

Main Office, Rocklin, Placer Co., Cal.
Telephone Main 82

GOODS OF QUALITY

A new syphon action closet at a moderate price that is not only ultra-efficient but pleasing in appearance and combining many new sanitary features.

On display at our show room—

64 Sutter Street, San Francisco

Main office and warehouse: Sixth, Townsend & Bluxome Sts.



Holbrook, Merrill & Stetson

Designers - Fabricators - Erectors

General Plate Work



Hydro - Pneumatic Pressure Tanks —
Hemispherical Bottom Tanks and Towers
— Oil and Water Tanks — Oil Stills —
Pipe Lines—Smoke Stacks—Well Casing
— Rock Screens — "Western" Corru-
gated Culvert Pipe.

Western Pipe and Steel Company

OF CALIFORNIA

444 MARKET STREET
SAN FRANCISCO

1758 NORTH BROADWAY
LOS ANGELES

A FLOORING for discriminating Architects and Builders, and characteristically a Michigan product in every way, from the excellence of the wood itself to the superior millwork and careful grading.

Strable Hardwood Co.
 HARDWOOD LUMBER
 Phone, Oakland 245
 511-545 FIRST STREET OAKLAND, CAL.

LA FRANCE SAFETY DEVICES
FOR EVERY INDUSTRY

Consider Fire Protection in Making Your Plans

If you are planning a factory provide a space for a LaFrance No. 20 Chemical Engine, for it is simple in construction and easy to operate. It contains twenty gallons of fluid forty times as effective as water for extinguishing fires. It is made by the world's largest manufacturer of fire apparatus, with a full knowledge of what is best for effective fire fighting.

Write for complete information in regard to this and our other appliances, such as Hose, Hose Raeks, Reels, Nozzles, Axes and many others.

AMERICAN LA FRANCE FIRE ENGINE COMPANY, INC.
 ELMIRA, N. Y.

929 South Hill Street, Los Angeles, Calif.  151 New Montgomery Street, San Francisco, Calif.

QUEBRACHO!

One coat Argentine Quebracho paint on steel will out-wear three of red lead and graphite at fraction of cost. Contains South American gum that gives great tenacity. Ask about records on steel; also for damp-proofing concrete and for protecting piling from teredoes.

IMP MANUFACTURING CO.
 Plaza Building, Oakland Phone Lakeside 478

TELEPHONE MISSION 1105

Pacific Foundry Company

CONTRACTORS' SUPPLIES
 Hand Hot Rollers, Tamping Irons, Smoothing Irons, Sewer Fittings

Send for Bulletins

18th and Harrison Sts., San Francisco

GENUINE SQUIRES STEAM TRAPS
 Great Durability and High Efficiency.
 Main joints above water line.
 Valve and Seat accessible without breaking joints.
 Every Trap unconditionally guaranteed.

W. E. MUSHET CO

SOLE AGENTS
 Phone Sutter 4797

502 Mission Street
 San Francisco, Cal.

LARGE STOCK ON HAND

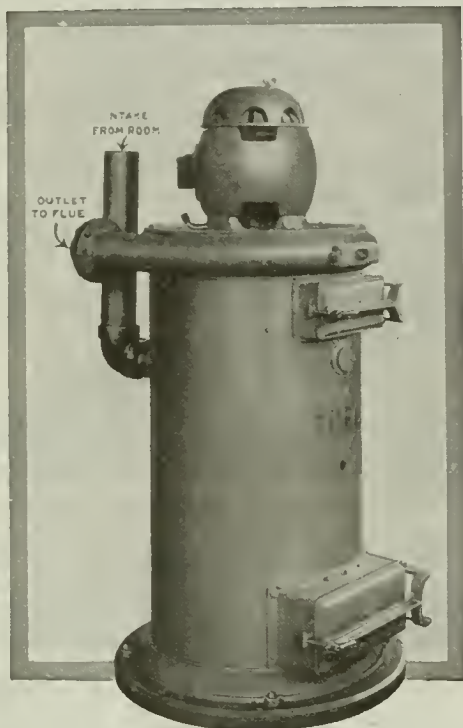

TUEC STATIONARY CLEANER.

THE cleaner that reduces building maintenance expense by keeping floors, walls, stairways, merchandise and other stocks, carpets, furniture and furnishings free from dust and dirt. No other cleaning device or dust removal method is so thorough, efficient, and economical. Investigate yourself and invite your client to do so. Write for our free catalog and full information.

THE UNITED ELECTRIC CO.

CANTON, OHIO.

Canadian Plant: Toronto, Ont.

California Distributors

S. F. COMPRESSED AIR CLEANING CO.
397 Sutter Street, San Francisco

BARKER BROS.

724 S. Broadway, Los Angeles



POSITIVE ELECTRIC INTERLOCK

(BAR LOCK TYPE)

Prevents Elevator Accidents Occurring at the Entrance Door

Approved by National Underwriters Laboratories—Meets requirements of Elevator Safety Orders of Industrial Accident Commission, State of California

ELEVATOR SUPPLIES COMPANY, Inc. 186 FIFTH STREET, SAN FRANCISCO

Capital \$1,000,000

CALIFORNIA DEPARTMENT

Surplus \$1,122,000

THE FIDELITY AND CASUALTY COMPANY OF NEW YORK

Prompt Service for

BONDS AND CASUALTY INSURANCE

203-206 Merchants Exchange Building

SAN FRANCISCO, CAL.

ANY PLACE ANY TIME PROMPTLY "We Serve You"

JOHN H. ROBERTSON

Successor to Robertson & Hall

GENERAL INSURANCE

Phone Sutter 2750

621 First National Bank Building, San Francisco

CONTRACT BONDS

Fidelity and Surety Bonds of every kind.

C. K. BENNETT, Manager

FIDELITY AND DEPOSIT COMPANY OF MARYLAND

Telephone Kearny 1452

622 Insurance Exchange, San Francisco, Calif.

PACIFIC DEPARTMENT

Globe Indemnity Company

BONDS and CASUALTY INSURANCE for CONTRACTORS

FRANK M. HALL, formerly Robertson & Hall, Mgr.

120 Leidesdorff Street Phone Sutter 2280 SAN FRANCISCO

National Surety Company of New York

The World's Largest Surety Company

Assets over \$20,000,000

Pacific Coast Department: 105 MONTGOMERY ST., SAN FRANCISCO, CAL.

Frank L. Gilbert, Vice-President

Phone, Sutter 2636

PHONE DOUGLAS 2370

McLERAN & PETERSON

GENERAL CONTRACTORS

HEARST BUILDING

SAN FRANCISCO, CAL.

L. J. RUEGG

J. B. RUEGG

RUEGG BROS.

CONTRACTORS AND BUILDERS

Phone Douglas 1599

719 Pacific Building, SAN FRANCISCO



Steel ^{Open} ^{Hearth} Bars ^{For Concrete} ^{Reinforcement}

Square, Deformed and Cold Twisted, Plain Rounds and Squares

PACIFIC COAST STEEL COMPANY

General Office, Rialto Building, San Francisco. Phone Sutter 1564

Sales Office, Rialto Building, SAN FRANCISCO
Sales Office, Union Oil Building, LOS ANGELES
Sales Office..... SEATTLE, WASH.

ROLLING MILLS:
SOUTH SAN FRANCISCO.....CAL.
SEATTLE, WASH. PORTLAND, ORE.

Architects and Building Contractors!

The HICKS-JUDD COMPANY, Inc., and SUNSET PUBLISHING HOUSE
have consolidated under the name of
ABBOTT-BRADY PRINTING CORPORATION
460 Fourth Street, San Francisco, Calif.

THE Binding of Magazines and Periodicals
will continue as one of Our Specialties;
also Expert Plate and Map Mounting.

Reprinting of The Architect and Engineer Advertisements for Circular or File Use

George S. MacGruer }
Robert M. Simpson } Members of Builders Exchange

MacGruer & Simpson

CONTRACTING PLASTERERS
PLAIN AND ORNAMENTAL

Cement, Stucco and Artificial Stone

Phone Sutter 5688

540 Call-Post Building, San Francisco

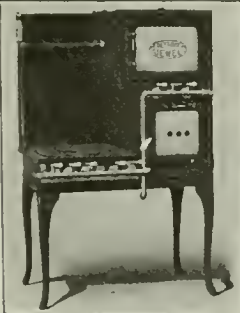

Detroit Jewel Gas Ranges

FOR HOME, RESTAURANT, HOTEL AND CLUB

We carry a Full Line of Stock Sizes

SELLING AGENTS

NATHAN DOHRMANN CO.

Gearry and Stockton Streets, San Francisco

PARMELEE-DOHRMANN CO.

436-444 S. BROADWAY, LOS ANGELES

CALIFORNIA ARTISTIC METAL & WIRE CO.
 J. T. McCORMICK, PRESIDENT
 ORNAMENTAL IRON AND BRONZE
 349-365 SEVENTH ST. SAN FRANCISCO

MORTENSON CONSTRUCTION CO.
 CONTRACTORS FOR STRUCTURAL STEEL AND IRON
 H. MORTENSON, PRES. CHAS. G. MORTENSON, VICE-PRES. AND MGR.
 OFFICE AND SHOPS: CORNER 19TH AND INDIANA STREETS
 PHONE: MISSION 5033 SAN FRANCISCO, CAL.

RAYMOND GRANITE COMPANY, Inc.
 Owing and operating at Knowles, Madera County, the largest Quarry in the world
 CONTRACTORS FOR STONE WORK
 Designers and Manufacturers of Exclusive Monuments and Mausoleums
 Main Office and Yard: No. 1 and 3 Potrero Avenue, San Francisco, California
 Also at 1350-Palmetto Street, Los Angeles

CAEN STONE  **A. KNOWLES**
 A refined, elegant, interior finish. CONTRACTOR and PLASTERER
 442 Call-Post Building San Francisco

THE GOLDEN GATE IRON WORKS
STRUCTURAL STEEL
 1541-1549 HOWARD STREET, BETWEEN 11th AND 12th STREETS
 Tel. Market 5445 SAN FRANCISCO

Telephone Mission 58 A. A. Devoto, President
CENTRAL IRON WORKS, Inc.
 STRUCTURAL STEEL
 Office 2050 BRYANT STREET SAN FRANCISCO, CAL.

JOHNS-MANVILLE
 SERVES IN CONSERVATION
 Through
ASBESTOS and its ALLIED PRODUCTS

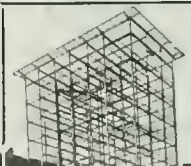
 **SCHRADER IRON WORKS, Inc.**
 STRUCTURAL STEEL CONTRACTORS
 Fire Escapes, Waterproof Trap Doors, Ornamental Iron Work
 1247-1249 HARRISON STREET SAN FRANCISCO, CAL.
 Bet. 8th and 9th Telephone Market 337

THE HYLOPLATE BLACKBOARD

SCHOOL FURNITURE
AUDITORIUM SEATING

MAPS
GLOBES
ATLASES

C. F. WEBER & CO.

985 Market Street
SAN FRANCISCO

222-224

S. Los Angeles St.
LOS ANGELES

100 W. Commercial
Row, RENO, NEV.

524 W. Washington
Street, PHOENIX, ARIZ.



**BEAUTIFUL GARDEN
EFFECTS** for the City
and Suburban Home

MacRORIE-McLAREN CO.

Landscape Engineers
and General Nurserymen



Office Nurseries at
141 Powell Street Beresford,
San Francisco San Mateo County

When writing to Advertisers please mention
this magazine.

Resists Fire

Freedom from pitch or resin gives California Redwood an unusual resistance to fire. For this reason Redwood construction, whether for home building, industrial, specialty, or engineering work, is long lasting.

Due to a natural preservative, Redwood also resists rot—a quality valuable in any industrial construction exposed to the elements or in contact with the ground.

CALIFORNIA REDWOOD
ASSOCIATION
San Francisco

California Redwood

Resists fire and rot

**THE HEART OF A BUILDING
IS ITS PIPING EQUIPMENT**

A complete line for the Piping Features of Buildings—Power, Plumbing, Heating, Ventilating, Refrigerating, Vacuum-Cleaning, Gas, Water, etc.—is furnished by Crane Co. through the Plumbing and Heating trade.

The Architect, Engineer and Builder, or Investor, may enjoy, through the facilities of this Company, the distinct advantage of dealing entirely with one Competent and Responsible House.

Exhibit Rooms, Offices and Warehouses in San Francisco and Oakland and Fifty-one other cities.

CRANE CO.

1855-1918

VALVES AND
FITTINGS

Telephone
DOUGLAS
2046

Butte Electrical Equipment Company

BEECO

TRADE MARK - REG.

530
FOLSOM
STREET

CONTRACTORS FOR POWER LIGHTING
AND INDUSTRIAL INSTALLATIONS

For the convenience and guidance of our customers,
we have adopted **BEECO** as our trade name.

SAFETY ELECTRIC COMPANY

MANUFACTURERS OF

SWITCHBOARDS
SAFETY SWITCHES
SAFETY CONTROLS



PANEL BOARDS
SAFETY PANELS
KNIFE SWITCHES

59-65 Columbia Square

San Francisco, Calif.

Telephone Market 2949

L. SIEBERT

J. GENSLER

Drendell Electrical & Mfg. Co.

Incorporated

SWITCHBOARDS, PANEL BOARDS, KNIFE SWITCHES,
CABINETS, THEATRE INSTALLATIONS,
PROTECTIVE POWER PANELS

1345-1353 Howard St., San Francisco

Telephone Market 1753

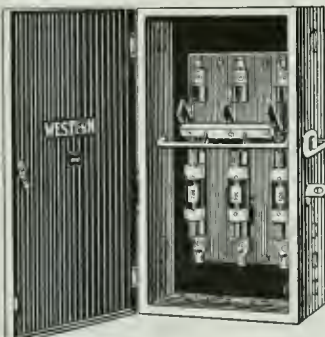

"TYPE C"

Western Safety Man'fg. Co. Inc.

Formerly

MEYERS ELECTRIC SAFETY SWITCH CO., Inc.

Manufacturers of

Enclosed Externally Operated Safety
Switches, Knife Switches, Metal Switch
and Cut Out Boxes, Safety Switch Boards

Office, 247 Minna Street

SAN FRANCISCO

Telephone, Sutter 3008

BUTTE ELECTRIC & MFG. CO. DOUGLAS 145

(Paul C. Butte) at it since 1904
WIRING FOR BUILDINGS

534 Folsom Street

SAN FRANCISCO

H. S. TITTLE

CONTRACTING ELECTRICAL ENGINEER

766 FOLSOM ST., SAN FRANCISCO

Phone SUTTER 4278



To Be "Low Bidder" Not Always Our Aim.

Our most particular attention is given to prompt and skillful handling of all electrical work of any nature with "QUALITY AND SERVICE GUARANTEED."

Our nation-wide organization and large experience in this field assures you always of fair estimates and absolute satisfaction.

F. E. NEWBERY ELECTRIC CO.

163 Sutter St. (413 Lick Bldg.) San Francisco, Phone Sutter 521

San Francisco, Cal.

Oakland, Cal.

Los Angeles, Cal.

NEPAGE, McKENNY CO.

Electrical Engineers and Contractors

Phone Sutter 2369

589 Howard St., San Francisco, Cal.

Phone Market 2541

M. FLATLAND

GLOBE ELECTRIC WORKS

Estimates Furnished on Everything Electrical

ELECTRIC SUPPLIES

1959 Mission Street, bet. 15th and 16th

SAN FRANCISCO

E. E. BROWNE

Telephone Douglas 976

C. A. LANGLAIS

**BROWNE-LANGLAIS ELECTRICAL
 CONSTRUCTION COMPANY**

213 Minna Street

SAN FRANCISCO

M. E. RYAN

Electrical Contractor

Phones: Store, Red. 250J
 Residence, Red. 250M

216 Main Street
 REDWOOD CITY, CAL.

Thomas J. Bennett

Edward W. Lauer

Rex Electric and Engineering Co.

Contracting and Repairing

253 Minna Street

Telephone Sutter 2148

San Francisco

Oakland 540

The Largest Exclusive Electrical House in the State

MOTORS

BOUGHT — SOLD
RENTED — REPAIRED

Lighting Fixtures

Manufactured

Construction

MAINTENANCE
SUPPLIES

Estimates and engineering data cheerfully furnished

SPOTT ELECTRICAL CO.

Yours for Service

16th & CLAY STREETS

OAKLAND, CALIFORNIA

KLINGSTONE

WILL NOT CRACK

Modern Flooring Requirements

¶ In this day of modern building construction, sanitary and fireproof requirements are sought by the architect in building specifications.

Klingstone Sanitary Flooring Rates 82%^o

—Cork tile, 72%^o; linoleum, 70%^o; oak or maple, 63%^o; white pine 62%^o; marble, 52%^o; rubber tile, 49%^o; clay tile, 43%^o; terrazo 43%^o; Portland Cement concrete, 42%^o; common brick rating 25%^o. ¶ KLINGSTONE SANITARY FLOORING is being extensively used in modern office buildings, schools, hospitals, factories, churches, railroad cars, steamships, hotels, public buildings, theatres, banks, stores, restaurants, cafes, garages, dairies, creameries, high-class residences and apartment houses.

¶ **GUARANTEE.** — We rigidly guarantee our KLINGSTONE Sanitary Flooring, and where applied according to our printed specifications, will replace, free of charge, any defective material, including labor for installing same.

NATIONAL MAGNESITE PRODUCTS CORPORATION

833 MARKET STREET, SAN FRANCISCO

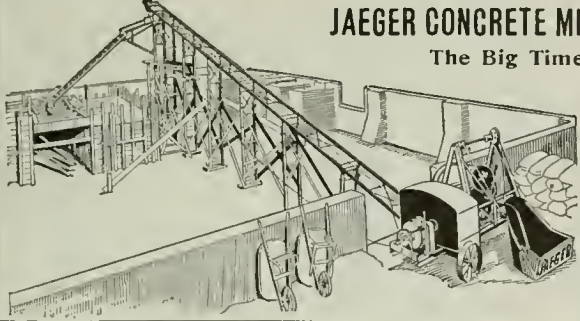

JAEGER CONCRETE MIXING AND PLACING PLANT
 The Big Time and Money Saver

All Sizes and Models in Stock

Edward R. Bacon Company

51 Minna St. 165 E. Jefferson St.
 SAN FRANCISCO LOS ANGELES

CONTRACTOR'S MACHINERY

RANSOME MIXERS OSHKOSH MIXERS
 INSLEY SPOUTING PLANTS
 OSHKOSH EVEREADY SAW RIGS INSLEY STEEL CARS and TRACKS
 HOISTING BUCKETS, HOPPERS, GATES, ETC.
 STEAM AND ELECTRIC HOISTS

EVERYTHING USED BY CONTRACTORS
 CARRIED IN STOCK BY

GARFIELD & CO.

Hearst Building, San Francisco Phone Sutter 1036

**LAKESWOOD - MILWAUKEE
 CONCRETE MIXERS**

ARE STURDY, HIGH SPEED, LABOR - SAVING MACHINES

Built in All Commercial Sizes. Driven by Kerosene Engine or Electric Motor.

COMPLETE STOCKS ON HAND





SMITH-BOOTH-USHER CO.
 SAN FRANCISCO-TAFT-LOS ANGELES

MACHINE TOOLS
 WOODWORKING MACHINERY
 ENGINES - MOTORS
 AIR COMPRESSORS - PUMPS
 POWER TRANSMISSION
 OIL & MINING EQUIPMENT
 CONSTRUCTION-INDUSTRIAL
 ROAD MAKING MACHINERY
 PIPE-FITTINGS-VALVES-SUPPLIES ETC.

CATALOG ON REQUEST

School and Theatre

STAGES AND EQUIPMENT

EDWIN H. FLAGG

SCENIC COMPANY, Inc.
400 Pantages Bldg., San Francisco, Cal.
1638 Long Beach Ave., Los Angeles, Cal.

MILLWORK Manufactured and Delivered Anywhere

Plans or Lists sent us for Estimates will have Careful and Immediate Attention.

Jno. Dudfield, Pres. and Manager **DUDFIELD LUMBER CO.** Joseph A. Jury, Sec'y & Mill Supt.

MAIN OFFICE, YARD AND PLANING MILL — PALO ALTO, CALIFORNIA

FRANK PORTMAN

MILL AND CABINET WORK

Window Frames and Inside Finish A Specialty
Band Sawing, Sticking and Sand Papering

1618-20 MISSION STREET

SAN FRANCISCO

ALL KINDS OF
MOULDINGS
IN STOCK

Phone Park 6204

A. C. SCHINDLER, President.

CHAS. F. STAUFFACHER, Secretary

THE FINK & SCHINDLER CO.

Manufacturers of INTERIOR WOODWORK AND FIXTURES
BANK, OFFICE AND STORE FITTINGS
SPECIAL FURNITURE

218-228 THIRTEENTH ST
Bet. Mission and Howard Sts.

SAN FRANCISCO, CAL.
Telephone: Market 474

O. BAMANN, President

ERNEST HELD, Vice-President

HOME MANUFACTURING CO.

BANK, STORE AND OFFICE FITTINGS
FURNITURE AND HARDWOOD INTERIORS
CABINET WORK OF EVERY DESCRIPTION

543 and 545 BRANNAN ST.

Phone Kearny 1514

San Francisco, Cal.

JAMES L. McLAUGHLIN

GENERAL CONTRACTOR

Phone Kearny 4654

251 KEARNY STREET, SAN FRANCISCO

MULLEN MANUFACTURING CO.

BANK, STORE AND OFFICE FIXTURES—CABINET WORK OF
GUARANTEED QUALITY—CHURCH SEATING

Telephone Market 8692

Office and Factory:
64 Rausch St., Bet. 7th and 8th Sts., San Francisco

Dolan Wrecking & Construction Co.

(D. J. DOLAN)

Lumber, Lath, Nails, Shingles, Doors, Windows
and Plumbing Supplies, New and Second Hand

Phone Market 4264

Office and Yard, 1607-1639 MARKET ST., SAN FRANCISCO

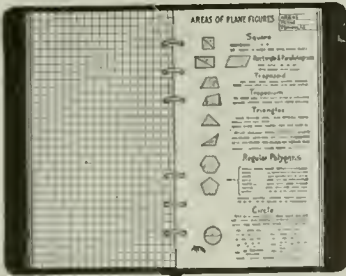

LEFAX

LEAF + FACTS

Pocket Cyclopedias

The facts that you want *instantly available* are not the same ones that some one else in your profession might desire. That's why LEFAX is made Loose Leaf. You file, in whatever order you wish, those sheets of facts that you want to have constantly at hand. If you wish, you may also file, in the same book, sheets for keeping data, for figuring, etc.

LEFAX sets cost but 50c. and \$1.00. You cannot fully appreciate their handiness—their value—until you use them. Ask us about them.

SCHWABACHER-FREY STATIONERY CO.
 PRINTERS LITHOGRAPHERS STATIONERS
 611 Market Street San Francisco

Steam Heating and Ventilating

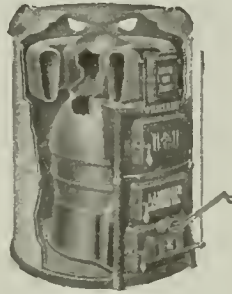

For Commercial and Public Buildings

Furnace Heating
 For the Home

Mangrum & Otter, Inc.

827-831 Mission Street
 Phone Kearny 3155 SAN FRANCISCO

"Talk—Don't Walk"

Baker, Hamilton & Pacific Co.; California Packing Corporation; J. Barth & Company; Robert Dollar Company; Bass-Imeter Paint Co.; Sperry Flour Company, So. Vallejo; J. D. & A. B. Spreckles Securities Co.

WHY are the above firms using the AUTOMATIC PRIVATE TELEPHONE SYSTEM?

BALFOUR, GUTHRIE Co.; HOWARD AUTOMOBILE COMPANY; U. S. MARINE HOSPITAL KNOW WHY, and are also installing the AUTOMATIC PRIVATE TELEPHONE SYSTEM.



DIRECT-LINE TELEPHONE COMPANY

Telephone Electrical Engineers
 THEODORE HALL, MANAGER
 320 MARKET STREET, SAN FRANCISCO
 Phone Douglas 722

Have you read "A Pair of Wires and A Dial?"

ROBERTS MFG. CO.

Lighting Fixtures
 Electric Appliances
 Incandescent Lamps

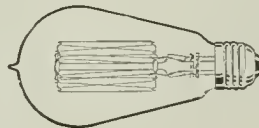

WILLYS FARM LIGHTING AND POWER PLANTS

663 Mission St., San Francisco

Washed Gravel and Sand

Quality For Concrete Construction *Service*

Thoroughly Washed and Accurately Graded—An Ideal Concrete Aggregate



View of Plant at Niles

California Building Material Co.

Plants at Eliot and Niles, Cal.

500 Call Building, San Francisco

Otis Elevators

THE Architect or Engineer can specify "Otis Elevators" assured that the responsibility of the Otis Elevator Company extends beyond satisfactory installation. Buildings equipped with Otis Elevators enjoy the advantage of the prompt service and careful inspection rendered by any of our hundred offices. Such service means your clients' gratitude.



Otis Elevator Company

Offices in All Principal Cities of the World
2300 Stockton Street, San Francisco, Calif.

The
ARCHITECT &
ENGINEER



FEBRUARY 1921

Published in San Francisco
35 cents a copy - \$2⁵⁰ a year

"CARRY ON"

Pacific quality was not lowered during the stressful war years, although an almost imperceptible departure from our high standards would have greatly increased production and sales.

We saw a vision of the return of a "buyer's market," when people could pick and choose and when the product which had not played square with the public would be the loser.

And, aside from purely business reasons, we wanted to be able to proudly take our place among those who "carried on."

PACIFIC PLUMBING FIXTURES



For Sale by All Jobbers

Main Offices: 67 New Montgomery Street, San Francisco
Factories: San Pablo and Richmond, California



HOYLE

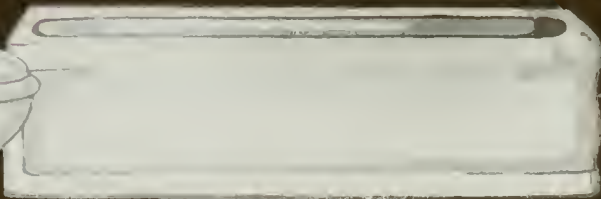
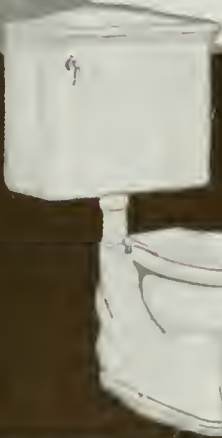

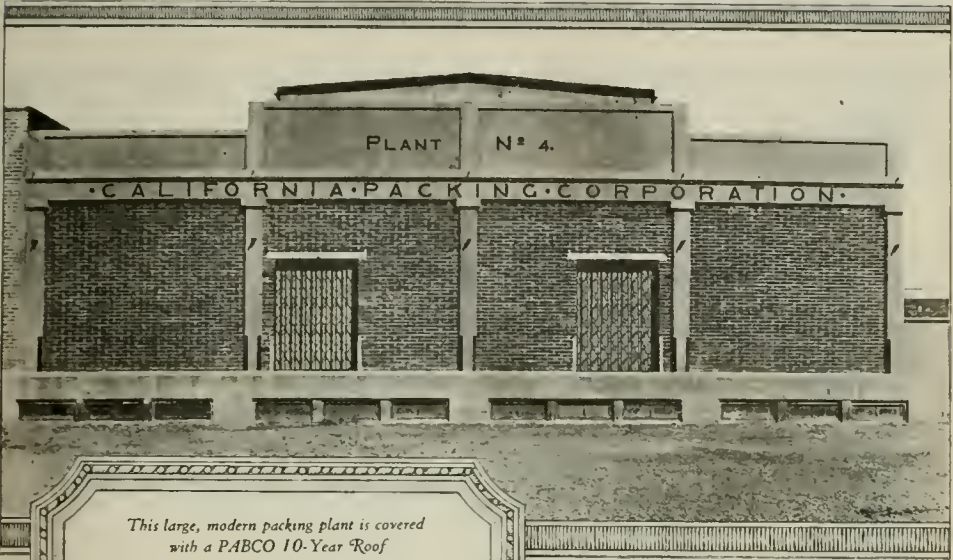

*This large, modern packing plant is covered
with a PABCO 10-Year Roof*

A Logical Reason

Many of the large industrial concerns of the West insist that their buildings be covered with PABCO Guaranteed Roofs—not only because they are the highest grade roofs but because they are guaranteed by The Paraffine Companies, Inc.—a \$6,000,000.00 institution with thirty-five years of successful experience.

PABCO 10 and 20-Year Roofs

also appeal to Architects and Engineers because

1. Under the guarantee, they are relieved of responsibility and all annoyance incident to roof troubles.
2. PABCO ROOFS are least expensive, because of *low cost per year of service.*

Write for Specifications and Complete Details

THE PARAFFINE COMPANIES, INC.
San Francisco, California

Plant N° 4
California Packing Corporation
San Jose, Cal.
Philip Bush
Engineer



Roofings, Felts
Roof Coatings
Building Papers
Wall-Boards
Floor Covering
Waterproofing
Materials
Paints
Electrical Varnishes
and Insulating
Compounds
Box-Board
Paper-Boxes
Fibre Containers

*"Each the standard
of its kind"*

*Announcing a New Development
in Lighting—through the use of*

Elexits

“Places for Lights”

IN the earlier issues of this magazine the Electric Outlet Company stated that new and far-reaching possibilities in lighting await the architectural profession, through the invention of a new flush receptacle made to finish off electric lighting outlets.

This company is now able to fulfill the promise of its earlier advertisements, and give more details regarding this important advancement.

Lighting outlets, when finished off with the new flush receptacles mentioned above are called *Elexits*.

Elexits are finished “places for lights.” They are safe. They are always ready for use. They are inconspicuous when not in use.

An Elexit will receive the standard attachment plug now furnished with nearly all electrical appliances. An Elexit also receives, through the same slots, an Elexit plug, which is a standardized fixture-supporting plug with curved parallel blades.

Standard and ornamental lighting fixtures may be fitted with these fixture-supporting plugs and at once become lighting portables.

Simply specify “Elexits”—and the locations where you want them. Receptacles for Elexits are made by several manufacturers, but only under license agreements with the Electric Outlet Company, that insure the maintenance of high standards of quality, precision and design. The same is true of the Elexit plugs furnished to lighting fixture manufacturers and dealers.

Elexit receptacles and plugs will be interchangeable, without regard to origin of manufacture. The face of all Elexit receptacles will have a rounded-triangular design, which makes them recognizable at a glance.

The Electric Outlet Company will use its patent protection on these plugs and receptacles to insure reliable standardization during the life of its patents, no matter how many additional manufacturers may be licensed.

Buy the usual lighting fixtures from your usual lighting fixture manufacturer. Simply specify that the fixtures are to come equipped with Elexit plugs.

*Elexits will
look like this*



*The inconspicuous
wall Elexit*



*The finished ceiling
Elexit*

Elexit plugs do not alter present-day construction of fixtures. They in no way complicate the continued sale of fixtures for the old-fashioned lighting outlets. Such outlets may, however, be changed to Elexits by installing Elexit receptacles.

This permits the gradual equipment of new and old buildings with Elexits—as their use can be extended without in any way interfering with present practice.

The use of Elexits makes possible the selection of lighting fixtures through experimentation to secure desired lighting effects—the exchange of fixtures without the expense and annoyance incident to employing an electrician for this work—the expression of personal taste and individual preference in the selection of lighting fixtures by a tenant—the provision of a larger number of outlets, and the re-arrangement of lights to correspond with furniture re-arrangements.

Names and addresses of all manufacturers licensed to make Elexit receptacles and plugs will be furnished upon request to any architect, lighting fixture manufacturer, or electrical contractor.

Requests for further details will be welcomed.

ELECTRIC OUTLET COMPANY

Inc.

119 West 40th St., New York City



This plug with or without a special hickey, makes practically any type of bracket ready to plug into wall Elexits



The two piece ceiling plug that makes a chandelier lock itself securely by its own weight into any ceiling Elexit

Receptacles for Elexits will fit nearly all Outlet Boxes

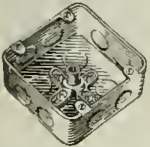

Receptacles for Elexits fasten on the fixture stud

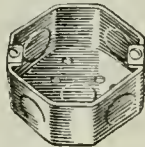

Receptacles for Elexits can be installed in a 4 inch round or octagon box

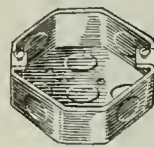

Receptacles for Elexits can be installed in a 3/4 inch octagon box

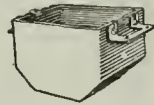

Receptacles for Elexits can be screwed onto the ears of a switch or receptacle box

Standard and Ornamental Fixtures can be plugged into Elexits

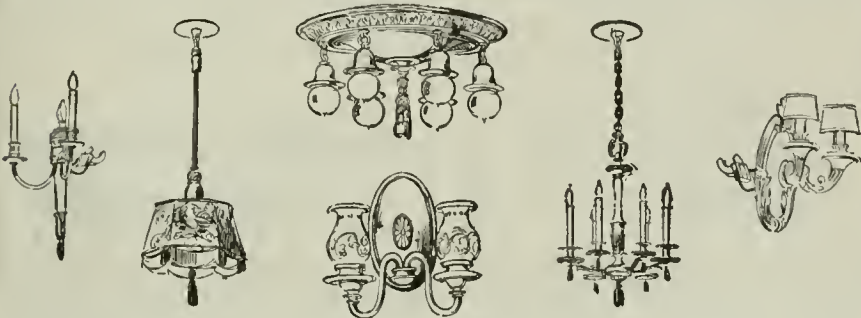

W. & J. SLOANE

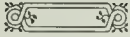

Carpetings Furniture

Rugs

Linoleum Window Shades

Wall Papers

Interior Decorations

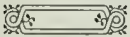

216-228 Sutter Street

Tel. Garfield 2838 San Francisco

TIME CLOCKS

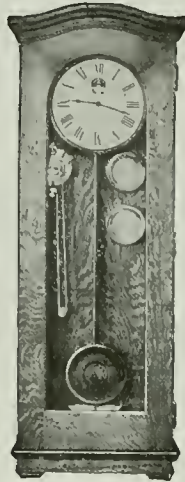

SCHOOLS must have uniform time to secure efficient results. They also need automatic sounding of the program Bells synchronized with the clocks.

All "Standard" Electric Time Equipments are guaranteed against any electrical or mechanical defects for a period of one year from date of installation. Specifications, blue prints and other information will be gladly furnished architects, engineers or officials for planning and installing "Standard" systems. Let us cooperate with you for securing the best results.

STANDARD ELECTRIC
TIME COMPANY

461 MARKET STREET

Phone Sutter 241

SAN FRANCISCO



PROMETHEUS

The Electric Food and Plate Warmer

Wherever meals are cooked and served, in apartments, residences and institutions, Prometheus is a highly valued asset. The wireless heating units placed independently of the shelves keep food hot and tasty until ready to serve and cannot injure the finest china.

Write for information and list of installations

The Prometheus Electric Co.

Manufacturers

511 West 42d Street, New York

Showroom, **M. E. HAMMOND**
Mezzanine Floor Pacific Bldg., San Francisco

CLOW

*Will your buildings be
giving good service
in 1950?*

THE plumbing system of a building may be a source of strength or weakness. Buildings where plumbing is continually "out of order" soon fall into disrepute and quickly decline in value.

Clow Plumbing installed throughout is a safeguard against future trouble from that source. The name "Clow" on plumbing has always stood for the very best obtainable.

SPECIFY "CLOW" FOR SAFETY AND SERVICE.

Frederick A. Hamilton

Sales Agent

Show Rooms:

RIALTO BUILDING
SAN FRANCISCO



STEEL BARS

FOR
CONCRETE REINFORCEMENT

CORRUGATED
TWISTED
SQUARES
OR
ROUNDS
CUT
TO
LENGTH



FABRICATED
AND
INSTALLED
—
LUMP SUM
BIDS
ON
WORK
COMPLETE

Office, 444 MARKET STREET
Warehouse, 10th and Bryant Streets
Phone: Sutter 2720

“HYDRATITE” FOR WATERPROOFING AND HARDENING CONCRETE “HORNSTONE”

General Machinery & Supply Co.

OFFICES AND STORE: 39-51 STEVENSON STREET

WAREHOUSES { 36-48 ECKER STREET AND
4TH STREET AT CHINA BASIN

TELEPHONE - PRIVATE EXCHANGE - SUTTER 6750

— AGENTS FOR —

EVERLASTING BLOW-OFF VALVES

WM. POWELL CO.'S { WHITE STAR VALVES - MODEL STAR VALVES
UNION COMPOSITE DISC VALVES AND PILOT GATE VALVES

YALE & TOWNE:—CHAIN HOISTS
FISHER AND SWARTWOUT STEAM SPECIALTIES

ENGINEER'S, MACHINIST'S AND STEAM FITTER'S SUPPLIES
PIPE, PIPE-FITTINGS, VALVES, BELTING, PACKING AND HOSE
TRANSMISSION AND CONVEYING MACHINERY

SEND US YOUR INQUIRIES

E. B. Noble, President
A. E. Wilkins, Vice-Pres.

Beam, Angle, Channels, and Universal Mill
Plates for immediate shipment from stock

Pacific Rolling Mill Co.

SUPPLIERS OF

FABRICATED STRUCTURAL STEEL, Forgings,
Bolts, Rivets, Frogs, Switches, Cast Iron Castings

General Office and Works
17th and MISSISSIPPI STS., SAN FRANCISCO
Telephone Market 215

Beams
Channels
Angles
Plates

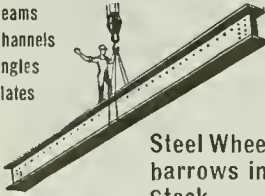

Steel Wheel-
barrows in
Stock

Western Iron Works

W. B. MORRIS, Pres. H. H. MORRIS, V.-P. L. J. GATES, Sec.

STRUCTURAL IRON AND
STEEL CONTRACTORS

141-147 Beale St. and 132-148 Main St. SAN FRANCISCO

Phones: GARFIELD 2575--2576

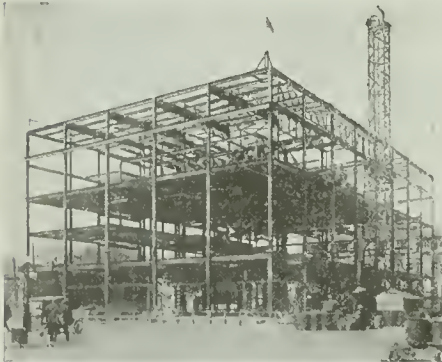

STEEL FRAME, MASONIC TEMPLE,
Sacramento. R. A. HEROLD, Architect.

STRUCTURAL STEEL
(600 tons) Fabricated and
Erected by

THE PALM IRON AND
BRIDGE WORKS (Incorporated)
15th and R Streets, Sacramento, Cal.

Cast Iron Stairs and Store Fronts

Bank and Office Railings, Elevator
Enclosures and Fire Escapes.

C. J. HILLARD CO., Inc.

Nineteenth and Minnesota Streets
Telephone Mission 1763

SAN FRANCISCO, CAL.

Architects' Specification Index

(For Index to Advertisements, see next page)

ART METAL

American Art Metal Works, 13 Grace street, San Francisco.

ARCHITECTURAL TERRA COTTA

Gladding, McBean & Company, Crocker Bldg., San Francisco.

Livermore Fire Brick Works, 604 Mission street, San Francisco.

ASBESTOS ROOFING, PACKING, ETC.

H. H. Robertson Co., Hobart Bldg., San Francisco.

H. W. Johns-Manville Co., San Francisco, Los Angeles and Portland, Ore.

AUTOMATIC SPRINKLERS

Grinnell Co. of the Pacific, 453 Mission St., San Francisco.

Pacific Fire Extinguisher Co., 424 Howard St., San Francisco.

AUTOMOBILE INSURANCE

Bankers & Shippers Insurance Co. of New York, Insurance Exchange Bldg., San Francisco.

AUTOMOBILES

W. L. Hughson Co., Geary St., at Van Ness Ave., San Francisco.

AWNINGS, TENTS, ETC.

W. A. Plummer, Front, at Pine St., San Francisco.

BANKS

First National Bank, Post and Montgomery streets, San Francisco.

BANK FIXTURES AND INTERIORS

Fink & Schindler, 218 13th St., San Francisco.

C. F. Weber & Co., 985 Market St., San Francisco.

Home Mfg. Co., 543 Brannan St., San Francisco.

Mullen Manufacturing Co., 64 Rausch St., San Francisco.

Rucker-Fuller Desk Co., 677 Mission St., San Francisco.

Pacific Manufacturing Company, San Francisco, Los Angeles, Oakland and Santa Clara.

BELTING AND PACKING

New York Belting and Packing Company, 519 Mission St., San Francisco.

H. N. Cook Belting Co., 401 Howard St., San Francisco.

Smith-Booth-Usher Co., San Francisco and Los Angeles.

BLACKBOARDS

C. F. Weber & Co., 985 Market St., San Francisco, Los Angeles and Reno, Nevada.

Beaver Blackboards and Greenboards, Rucker-Fuller Desk Company, Coast agents, 677 Mission St., San Francisco; also Oakland and Los Angeles.

BLINDS—VENETIAN AND DIFFUSELITE

J. G. Wilson Corporation, Metropolitan Bldg., Los Angeles; Waterhouse-Wilcox, Underwood Bldg., San Francisco.

Western Venetian Blind Co., Long Beach Ave., Los Angeles; C. F. Weber & Co., San Francisco.

BOILERS

California Hydraulic Engineering & Supply Co., 70-72 Fremont St., San Francisco.

General Boilers Co., 322 Monadnock Bldg., San Francisco.

Kewanee Water Supply System, Simonds Machinery Co., 117 New Montgomery St., San Francisco.

BOOK BINDERS

Abbott-Brady Printing Corp'n, 460 Fourth St., San Francisco.

H. S. Crocker Co., 565 Market St., San Francisco.

BONDS FOR CONTRACTORS

American Mutual Liability Insurance Co., Balboa Bldg., San Francisco.

Bonding Company of America, Kohl Bldg., San Francisco.

Bankers & Shippers Insurance Co. of New York, Insurance Exchange Bldg., San Francisco.

Globe Indemnity Co., 120 Leidesdorff St., San Francisco.

Fidelity & Casualty Co. of New York, Merchants Exchange Bldg., San Francisco.

Fidelity & Deposit Co. of Maryland, Insurance Exchange, San Francisco.

John H. Robertson, 621 First National Bank Building, San Francisco.

National Surety Co. of New York, 105' Montgomery St., San Francisco.

BRASS GOODS, CASTINGS, ETC.

H. Mueller Manufacturing Co., 635 Mission St., San Francisco.

BRICK, PRESSED, PAVING, ETC.

California Brick Company, 604 Mission street, San Francisco.

Livermore Fire Brick Works, 604 Mission street, San Francisco.

Los Angeles Pressed Brick Co., Frost Bldg., Los Angeles.

United Materials Co., Crossley Bldg., San Francisco.

Cannon & Co., Sacramento; and 77 O'Farrell street, San Francisco.

BRICK & CEMENT COATING

Armorite and Concreta, manufactured by W. P. Fuller & Co., all principal Coast cities.

The Paraffine Companies, Inc., 34 First St., San Francisco.

R. N. Nason & Co., 151 Potrero Ave., San Francisco.

Wadsworth, Howland & Co., Inc., Boston, Mass., manufacturers of Bay State Brick & Cement Coating. Hampley & Son, agents, San Francisco and Los Angeles.

BRICK STAINS

Samuel Cabot Mfg. Co., Boston, Mass., agencies in San Francisco, Oakland, Los Angeles, Portland, Tacoma and Spokane.

Armorite and Concreta, manufactured by W. P. Fuller & Co., all principal Coast cities.

BUILDERS' HARDWARE

Joost Bros., agents for Russell & Erwin Hardware, 1053 Market St., San Francisco.

The Stanley Works, New Britain, Conn., represented in San Francisco and Los Angeles by John Rountree & Co.

Palace Hardware Company, Agents Corbin goods, 581 Market St., San Francisco.

Richards-Wilcox Mfg. Co., Aurora; Ewing-Lewis Co., 626 Underwood Bldg., San Francisco.

GRINNELL AUTOMATIC SPRINKLER GRINNELL COMPANY

OF THE PACIFIC

VALVES
PIPE and FITTINGS

ENGINEERS AND CONTRACTORS
453 Mission Street, San Francisco

CHEMICAL FIRE
EXTINGUISHERS
and FIRE ENGINES

An Index to the Advertisements

	Page		Page		Page
Abbott-Brady Printing Corp.	151	Globe Indemnity Co.	150	Pacific Pump & Supply Co.	38
American Art Metal Works	30	Go-Sign & Letter Co.	145	Pacific Rolling Mills	6
American Face Brick Ass'n	129	Golden Gate Ornamental Iron Co.	152	Palace Hardware Co.	38
American Insulox Co.	22	Grinnell Co.	7	Palm Iron Works	6
American La France Fire Engine Co.	148	Gunn Carle Company	5	Palmer & Petersen	142
American Mutual Liability Insurance Co.	10	Haines, Jones & Cadbury	131	Paraffine Companies, Inc.	161
American Mail Chute	28	Hamilton, F. A.	4	Parker, K. E. Co., Inc.	141
American Marble & Mosaic Co.	44	Hannah, J. D.	142	Petrium Sanitary Sink Co.	145
American Rolling Mill Co.	134	Hauser Window Co.	36	Phillips, Chas. T.	29
American Standard Oil Burner	43	Haws Sanitary Drinking Faucet Co.	138	Pittsburg Water Heater Co.	148
American Window Glass Co.	42	Hillard, C. J., Co.	6	Plummer, W. A.	138
Atlas Heating & Ventilating Co.	146	Hill, Hubbell & Company	25	Pope & Talbot	15
Bacon, Edward R., Co.	132	Holbrook, Merrill & Stetson	147	Portland Lumber Co.	15
Badt-Falk & Co.	145	Home Mfg. Co.	158	Portland Cement Ass'n	117
Baird-Bailhache Company	34	Hughson, W. L. Co.	26	Portman, Frank	158
Bankers' & Shippers' Ins. Co.	132	Hunt, Robt. W. & Co.	132	Power Construction Company	136
Barrett & Hilp	144	Hunter & Hudson	140	Prometheus Electric Co.	4
Bartlett, John M.	136	Ideal Heating & Engineering Co.	146	Raymond Granite Co.	152
Bass-Hueter Co.	3rd Cover	Illinois Engineering Co.	146	Redwood Manufacturers	42
Beach-Robinson Co.	27	Imp Mfg. Co.	148	Reliance-Grant Elevator Equipment Co.	22
Beckwith, Herbert	145	Imperial Waterproofing	28	Ringius, John	136
Bowser & Co., S. F.	41	James & Drucker	146	Roberts Mfg. Co.	159
Breuner, John	136	Jarvis, T. P. Mfg. Co.	43	Robertson Co., H. H.	11
Brininstool Co.	22	Johns-Manville Co.	152	Robertson, John H.	150
Brown, Arthur	118	Johnson, S. T.	43	Ruegg Bros.	150
Browne-Langlais Company	155	Johnson Service Co.	11	Rucker-Fuller Desk Co.	140
Builders and Roofers Exchange	120	Joost Brothers	140	Ryan, M. E.	155
Butte Electrical Equipment Co.	154	Kawneer Mfg. Co.	143	Safety Electric Co.	154
Butte Electric & Mfg. Co.	155	Key-hold Plaster Lath Co.	28	Sampson Spot Cord	136
Cabot, Samuel (Inc.)	41	Kissel, I. R.	142	Scott Co.	146
California Artistic Metal and Wire Co.	152	Knittle-Cashel Co., Inc.	13	Schrader Iron Works	152
California Bldg. Material Co.	160	Knowles, A.	152	Schwabacher-Frey Co.	159
California Brick Co.	33	Lange & Bergstrom	157	Sloane, W. & J.	4
California Granite Co.	146	Leiter, E. T. & Son	136	Simmons, O. M. Co.	12
California Hydraulic Engineering and Supply Co.	10	Liberty Electric Co.	155	Simonds Machinery Co.	127
California Paint Co.	14	Littlefield, R. W.	144	Smith-Booth-Usher Co.	157
California Plastic Products Co.	137	Livermore Fire Brick Works	33	Smith, Jas. F.	144
California Redwood Ass'n	153	Los Angeles Pressed Brick Co.	128	Sommer, I. M.	144
California Steam and Plumbing Supply Co.	137	MacGruer & Simpson	151	Sonnenschein Bros.	27
Cannon & Co.	24	MacRorie-McLaren Co.	153	Soulé, Edward L. Co.	132
Cement Gun Construction Co.	120	Magner Bros.	140	Spencer Elevator Co.	34
Central Electric Co.	148	Mangrum & Otter	159	Spott Electrical Co.	156
Central Iron Works	152	Marshall & Stearns Co.	141	Standard Varnish Works	123
Cobbleck-Kibbe Glass Co.	136	McClenahan Products Co.	27	Standard Electric Time Co.	4
Coleman, Alex	146	McCray Refrigerator Co.	28	Standard Fence Co.	145
Collman & Spidel	142	McLaughlin, Jas. L.	158	Stanley Works, The	113
Cook Belting Co.	38	McLeran & Peterson	150	Steelform Contracting Co.	144
Cowell Lime & Cement Co.	143	McNab, H. N.	145	Steel Studing Co.	137
Crane Co.	153	Medusa Cement	23	St. Francis Hotel	127
Crocker, H. S. Co.	134	Meese & Gottfried	118	Stockholm, Chas. & Son	136
Davis, R. J.	9	Millmen's Audit Bureau	124	Strable Hardwood Co.	121
Del Favero and Rasori	142	Moline Heat	16	Sunset Lumber Company	15
Del Monte Properties Co.	20	Montague Range & Furnace Co.	18	Tay Company, George H.	31
Detroit Steel Products Co.	44	Monson Bros.	142	Taylor Galleries	119
Dieckmann Hardwood Co.	12	Mortenson Construction Co.	152	Tittle, H. S.	155
Direct Line Telephone Co.	159	Mott Co. of Calif.	18	Tormey Co.	140
Dolan Wrecking & Construction Co.	158	Mueller Mfg. Co.	18	Trost, Robt.	142
Drendell Elec. & Mfg. Co.	154	Mullen Mfg. Co.	158	Truscon Steel Co.	26
Dudfield Lumber Co.	158	Musht Co., W. E.	125	U-Turn-It Housekeeping System	135
Duncan, W. C.	144	Musto Sons Keenan Co.	13	Uhl Bros.	38
Dunham, C. A. Co.	31	Myers & Schwartz	32	Unit Construction Co.	142
Eberhard Faber	37	Nason, R. N. & Co.	9	United Electric Co.	149
Electric Outlet Co.	2 and 3	Nathan, Dohrmann Co.	151	United Materials Co.	128
Elevator Supplies Co.	150	National Magnesite Co.	156	U. S. Metal Products Co.	36
Ellery Arms Co.	140	National Mill & Lumber Co.	29	U. S. Steel Products Co.	40
Fess System Co.	43	National Surety Co.	150	Van Fleet-Frear Co.	143
Fidelity & Casualty Co. of N.Y.	150	National Terra Cotta Society	115	Vermont Marble Co.	148
Fidelity & Deposit Co. of Maryland	150	National Valve Co.	130	Verkceovich & Bagge	144
Fink & Schindler Co., The	158	National Window Shade Co.	122	Wadsworth, Howland & Co., Inc	120
Fire Protection Products Co.	36	Nelson, James A.	18	Walter, D. N. & E. & Co.	145
First National Bank	118	Ne Page, McKenny Co.	155	Ward, Baldwin D.	140
Flagg, Edwin H., Scenic Co.	158	Newbery Electric Co.	155	Waterhouse, Wilcox Co.	28
Freeman Art Shop	27	New York Belting and Packing Co.	130	Wayne Oil Tank & Pump Co.	29
Fuller & Goepf	34	Norris Co., L. A.	122	Weber, C. F. & Co.	153
Fuller, W. P. Co.	19	Oak Flooring Mfrs' Ass'n	21	Westworth, F. W.	148
Garfield Company	157	Ocean Shore Iron Works	138	West Coast Porcelain Co.	Back Cover
Garnett, Young & Co.	20	Old Mission Portland Cement Co.	35	Western Blind & Screen Co.	39
General Boilers Co.	24	Otis Elevator Co.	160	Western Safety Mfg. Co.	154
General Machinery & Supply Co.	5	Pacific Coast Steel Company	151	Western Iron Works	6
Gilley-Schmid Co.	140	Pacific Electric Clock Co.	123	Western Pipe and Steel Co.	147
Gladding, McBean & Co.	138	Pacific Fire Extinguisher Co.	143	White Bros.	112
Globe Electric Works	155	Pacific Mfg. Co.	15	Wilson, J. G., Corp.	139
		Pacific Materials Co.	23-41-44	Wilson, W. F., Co.	146
		Pacific Painting and Roofing Co.	14	Witt, G. E. Co.	44
		Pacific Plumbing Fixtures, 2d Cover	2d Cover	Zelinsky, D. & Sons	145
		Pacific Porcelain Ware Co., 2d Cover	2d Cover		

Nason's Opaque Flat Finish

A Flat Washable Oil Paint, made in soft Kalsomine tints—a practical article for Walls, Ceilings, Etc. Agency for Tamm & Nolan Company's High Grade VARNISHES and FINISHES, made on the Pacific Coast to stand our climatic conditions.

R. N. NASON & CO. Paint Makers
151 Potrero Ave.—436 Market St., San Francisco—Portland—Seattle—Oregon

ARCHITECTS' SPECIFICATION INDEX—Continued

- BUILDING MATERIALS, SUPPLIES, ETC.**
California Brick Company, 604 Mission street, San Francisco.
Livermore Fire Brick Works, 604 Mission street, San Francisco.
Pacific Materials Co., Underwood Bldg., San Francisco.
Waterhouse-Wilcox Co., 523 Market St., San Francisco.
Johns-Manville Company, Post and Mason Sts., San Francisco.
- CABINET MAKERS**
Home Manufacturing Company, 543 Brannan St., San Francisco.
Fink & Schindler Co., 218 13th St., San Francisco.
Mullen Manufacturing Company, 64 Rausch St., San Francisco.
Frank Portman, 1618 Mission St., San Francisco.
- CARPETS**
W. & J. Sloane, 216-228 Sutter St., San Francisco.
John Breuner Co., 281 Geary St., San Francisco.
D. N. & E. Walter, Mission near Second street, San Francisco.
- CASEMENT WINDOW HARDWARE**
Richards-Wilcox Mfg. Co., Aurora, Ill., and Underwood Bldg., San Francisco.
- CEMENT**
Mt. Diablo, sold by Henry Cowell Lime & Cement Co., 2 Market St., San Francisco.
Medusa White Portland Cement, manufactured by Sandusky Cement Co., represented in San Francisco by Pacific Building Materials Co., Underwood Bldg., San Francisco.
Old Mission Portland Cement Co., Mills Building San Francisco.
- CEMENT EXTERIOR WATERPROOF PAINT**
Armorite, sold by W. P. Fuller & Co., all principal Coast cities.
Bay State Brick and Cement Coating, manufactured by Wadsworth, Howland Co., Boston, Mass. James Hambley & Son, Distributors, San Francisco and Los Angeles.
Hill, Hubbell & Company, No. 1 Drumm St., San Francisco.
Imperial Waterproofing, manufactured by Brooks & Doerr, Reed Baxter, agent, Merchants National Bank Bldg., San Francisco.
Paraffine Paint Co., 34 First St., San Francisco.
Medusa White Portland Cement, manufactured by Sandusky Cement Co., represented in San Francisco by Pacific Materials Co., 525 Market St., San Francisco.
- CEMENT GUN**
Cement Gun Construction Company of California, 701 Balboa Bldg., San Francisco.
- CEMENT TESTS—CHEMICAL ENGINEERS**
Robert W. Hunt & Co., 251 Kearny St., San Francisco.
- CLAY PRODUCTS**
California Brick Company, 604 Mission street, San Francisco.
Cannon & Co., Sacramento; and Chronicle Bldg., San Francisco.
Gladding, McBean & Co., Crocker Bldg., San Francisco.
Livermore Fire Brick Works, 604 Mission street, San Francisco.
- Los Angeles Pressed Brick Co., Frost Bldg., Los Angeles.
United Materials Co., Sharon Bldg., San Francisco.
- CLOCKS—ELECTRIC TIME**
Pacific Electric Clock Co., 516 Wells-Fargo Bldg., San Francisco.
Standard Electric Time Co., 461 Market St., San Francisco.
- COLD STORAGE PLANTS**
H. W. Johns-Manville Co., Post and Mason Sts., San Francisco.
T. P. Jarvis Crude Oil Burning Co., 275 Connecticut St., San Francisco.
- COMPRESSED AIR CLEANERS**
United Electric Co., Canton, O., mfr. of Tuec Cleaner, sold by San Francisco Compressed Air Cleaning Co., Sutter and Stockton Sts., San Francisco.
George H. Tay Company, Mission and Second Sts., San Francisco; 10th and Harrison Sts., Oakland.
- CONCRETE CONSTRUCTION**
Barrett & Hilp, Sharon Bldg., San Francisco.
Clinton Construction Co., 140 Townsend street, San Francisco.
K. E. Parker Co., Inc., Clunie Bldg., San Francisco.
Palmer & Petersen, Monadnock Bldg., San Francisco.
I. M. Sommer, 401 Balboa Bldg., San Francisco.
Steelform Contracting Company, 681 Market St., San Francisco.
- CONCRETE HARDENER**
Gunn, Carle & Co., Inc., 444 Market street, San Francisco.
- CONCRETE MIXERS**
Foote and Jaeger mixers sold by Edward R. Bacon Co., 51 Minna St., San Francisco, also Los Angeles.
Ransome mixers sold by the Garfield Co., Hearst Bldg., San Francisco.
Smith-Booth-Usher Co., San Francisco and Los Angeles.
- CONCRETE REINFORCEMENT**
United States Steel Products Co., San Francisco, Los Angeles, Portland and Seattle.
Twisted Bars. Sold by Gunn, Carle & Co., Inc., 444 Market St., San Francisco.
Clinton Welded Wire Fabric, L. A. Norris Co., 140 Townsend St., San Francisco.
Pacific Coast Steel Company, Rialto Bldg., San Francisco.
Triangle Mesh Fabric. Sales agents, Pacific Materials Co., 525 Market St., San Francisco.
Truscon Steel Co., 527 Tenth St., San Francisco.
Badt-Falk Co., Call-Post Bldg., San Francisco.
- CONDUITS**
Garnett Young & Co., 612 Howard St., San Francisco.
- CONTRACTORS, GENERAL**
Barrett & Hilp, Sharon Bldg., San Francisco.
K. E. Parker Co., Inc., Clunie Bldg., San Francisco.
R. W. Littlefield, 357 12th St., Oakland.
Unit Construction Co., Phelan Bldg., San Francisco.
J. D. Hannah, 142 Sansome St., San Francisco.

R. J. Davis

District Sales
Agent

Century

**A. C. Motors
and Fans**

Complete stocks carried at: 171-173 Second St., San Francisco; 906 So. Hope St., Los Angeles

We have returned to our policy-holders annually for 33 years never less than 30% of the premium as a dividend. Dividends declared during 1919, \$2,017,893.

AMERICAN MUTUAL LIABILITY INSURANCE CO. OF BOSTON
 Assets \$8,654,667 Surplus \$1,417,173

WORKMEN'S COMPENSATION, AUTOMOBILE, TEAMS AND PUBLIC LIABILITY INSURANCE

SAN FRANCISCO BRANCH OFFICE

1816 Balboa Building. Telephone Kearny 3202

N. F. Hesseltine, California Manager.

C. H. Gray, Assistant Manager.

ARCHITECTS' SPECIFICATION INDEX—Continued

- CONTRACTORS, GENERAL—Continued**
 John M. Bartlett, 357 Twelfth St., Oakland.
 E. T. Leiter & Son, Call-Post Bldg., San Francisco.
 Chas. Stockholm & Son, Monadnock Bldg., San Francisco.
 Herbert Beckwith, 323 Newton Ave., Oakland.
 Collman & Speidel, 546 Monadnock Bldg., San Francisco.
Clinton Construction Company, 140 Townsend St., San Francisco.
 Monson Bros., 1907 Bryant St., San Francisco.
 W. C. Duncan & Co., 526 Sharon Bldg., San Francisco.
 A. Knowles, Call-Post Bldg., San Francisco.
 T. B. Goodwin, 180 Jessie St., San Francisco.
 Lange & Bergstrom, Sharon Bldg., San Francisco.
 McLeran & Peterson, Hearst Bldg., San Francisco.
 Robert Trost, 26th and Howard Sts., San Francisco.
 I. M. Sommer, 401 Balboa Bldg., San Francisco.
 Del Favero & Rasori, 180 Jessie St., San Francisco.
 Jas. L. McLaughlin, 251 Kearny street, San Francisco.
- CONTRACTORS' EQUIPMENT**
 Edward R. Bacon Co., 51 Minna St., San Francisco, and Los Angeles.
 Garfield & Co., Hearst Bldg., San Francisco.
 Smith, Booth-Usher Co., 60 Fremont St., San Francisco; 228 Central Ave., Los Angeles.
- CONTRACTORS' INSURANCE**
 Bankers & Shippers Insurance Co. of New York, Insurance Exchange Bldg., San York.
- CONVEYING MACHINERY**
 Meese & Gottfried, San Francisco, Los Angeles, Portland and Seattle.
- CORK TILE, INSULATION, ETC.**
 Van Fleet-Freear Co., Sharon Bldg., San Francisco.
- CRUSHED ROCK**
 Coast Rock & Gravel Co., Call-Post Bldg., San Francisco.
- DAMP-PROOFING COMPOUND**
 Armoritite Damp Resisting Paint, made by W. P. Fuller & Co., San Francisco.
 Gunn, Carle & Co., Inc., 444 First street, San Francisco.
 Hill, Hubbell & Company, No. 1 Drumm St., San Francisco.
 Imperial Waterproofing, mfrd. by Brooks & Doerr, Reed Baxter, agent, Merchants National Bank Bldg., San Francisco.
 "Pahco" Damp-Proofing Compound, sold by Paraffine Co., 34 First St., San Francisco.
- DOOR HANGERS**
 Pitcher Hanger, sold by National Lumber Co., 326 Market St., San Francisco.
 Reliance Hanger, sold by Waterhouse-Wilcox Co., San Francisco; D. F. Fryer & Co., B. V. Collins, Los Angeles, and Columbia Wire & Iron Works, Portland, Oregon.
 Stanley Works, New Britain, Conn. John Rountree, agent, Monadnock Bldg., San Francisco.
 Richards-Wilcox Mfg. Co., Underwood Bldg., San Francisco.
- DRINKING FOUNTAINS**
 Haws Sanitary Drinking Faucet Co., 1808 Harmon St. Berkeley, and C. F. Weber & Co., San Francisco and Los Angeles.
- Crane Company, San Francisco, Oakland, and Los Angeles.
 Pacific Porcelain Ware Co., 67 New Montgomery St., San Francisco.
 George H. Tay Company, Mission and Second Sts., San Francisco; 10th and Harrison Sts., Oakland.
 Haines, Jones & Cadbury Co., 857 Folsom St., San Francisco.
- DUMB WAITERS**
 Spencer Elevator Company, 166 7th St., San Francisco.
 M. E. Hammond, Pacific Bldg., San Francisco.
- ELECTRICAL CONTRACTORS**
 Butte Electrical Equipment Company, 530 Folsom St., San Francisco.
 Butte Electric & Manufacturing Co., 534 Folsom St., San Francisco.
 Brown-Langlais Electrical Construction Co., 213 Minna St., San Francisco.
 Central Electric Company, 185 Stevenson street, San Francisco.
 NePage, McKenny Co., 589 Howard St., San Francisco.
 Liberty Electric Company, 479 Sutter St., San Francisco.
 Newbery Electrical Co., 413 Lick Bldg., San Francisco.
 Pacific Fire Extinguisher Co., 424 Howard St., San Francisco.
 Globe Electric Works, 1959 Mission St., San Francisco.
 M. E. Ryan, Redwood City, Calif.
 H. S. Tittle, 766 Folsom St., San Francisco.
 Severin Electrical Company, 185 Stevenson St., San Francisco.
 Spott Electrical Co., Sixteenth and Clay Sts., Oakland.
- ELECTRIC PLATE WARMER**
 The Prometheus Electric Plate Warmer for residences, clubs, hotels, etc. Sold by M. E. Hammond, Pacific Bldg., San Francisco.
- ELECTRICAL SUPPLIES AND EQUIPMENT**
 Garnett Young & Co., 612 Howard St., San Francisco.
 Butte Electrical Equipment Co., 530 Folsom St., San Francisco.
 Electric Outlet Co., Inc., 119 West 40th St., New York.
 Safety Electric Company, 56-65 Columbia Square, San Francisco.
 Drendell Electrical & Mfg. Co., 1345 Howard St., San Francisco.
 R. J. Davis, District Sales Agent, Century A. C. Motors and Fans, 171 Second St., San Francisco.
 Western Electric Safety Mfg. Co., Inc., 247 Minna street, San Francisco.
- ELEVATORS**
 Otis Elevator Company, Stockton and North Point, San Francisco.
 Spencer Elevator Company, 166 7th St., San Francisco.
- ELEVATOR EQUIPMENT**
 Elevator Supplies Company, Inc., 186 Fifth St., San Francisco.
- ENGINEERS—CONSULTING, ELECTRICAL, MECHANICAL**
 Chas. T. Phillips, Pacific Bldg., San Francisco.
 Hunter & Hudson, Rialto Bldg., San Francisco.
 Baldwin D. Ward, 76 13th St., Oakland.

KEWANEE
GARBAGE BURNERS
 AND
BOILERS

YEOMANS
BILGE PUMPS
EJECTORS
HOUSE PUMPS

OVERHEAD
CARRYING
SYSTEMS

CALIFORNIA HYDRAULIC ENGINEERING & SUPPLY CO., 80 Fremont St., S. F.

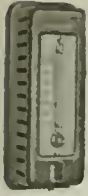

TEMPERATURE REGULATION

JOHNSON SERVICE COMPANY

(OF MILWAUKEE — ESTABLISHED 1885)

Manufacturers and Installers of **JOHNSON Heat Humidity CONTROL**
 For schools, residences, hospitals, banks, public buildings, also canneries and all kinds of industrial plants—Hot water tank regulators, air and water reducing valves.

Rialto Bldg., SAN FRANCISCO 605 Van Nuys Bldg., LOS ANGELES



ARCHITECTS' SPECIFICATION INDEX—Continued

- ELEVATOR DOOR HARDWARE**
 Richards-Wilcox Mfg. Co., Underwood Bldg., San Francisco.
- FANS AND BLOWERS**
 Ideal Heating & Engineering Co., 192 Erie St., San Francisco.
- FENCES—WIRE**
 Standard Fence Construction Co., 245 Market St., San Francisco, and 310 12th St., Oakland.
- FILLING STATION EQUIPMENT**
 S. F. Bowser & Co., Inc., 612 Howard St., San Francisco.
 Wayne Oil Tank & Pump Co., 631 Howard St., San Francisco, 830 S. Los Angeles St., Los Angeles.
- FIRE BRICK**
 Livermore Fire Brick Works, 604 Mission street, San Francisco.
- FIRE ESCAPES**
 Palm Iron & Bridge Works, Sacramento.
 Western Iron Works, 141 Beale St., San Francisco.
 Golden Gate Iron Works, 1541 Howard St., San Francisco.
- FIRE EXTINGUISHERS**
 American La France Fire Engine Co., Inc., 151 New Montgomery St., San Francisco; Los Angeles and Portland.
- FIRE INSURANCE**
 Bankers & Shippers Insurance Co., Insurance Exchange Bldg., San Francisco.
- FIRE PROOFING**
 American Insulux Company, Berkeley Bank Bldg., Berkeley.
- FIRE SPRINKLERS—AUTOMATIC**
 Grinnell Company, 453 Mission St., San Francisco.
 Pacific Fire Extinguisher Co., 424 Howard St., San Francisco.
- FIRE RETARDING PAINT**
 The Paraffine Companies, Inc., 34 First St., San Francisco.
- FIXTURES—BANK, OFFICE, STORE, ETC.**
 Home Manufacturing Company, 543 Brannan St., San Francisco.
 The Fink & Schindler Co., 218 13th St., San Francisco.
 Mullen Manufacturing Co., 64 Rausch St., San Francisco.
 C. F. Weber & Co., 985 Market St., San Francisco, and 210 N. Main St., Los Angeles, Cal.
- FLOOR TILE**
 Mangrum & Otter, 827 Mission St., San Francisco.
- FLOOR VARNISH**
 Bass-Hueter and San Francisco Pioneer Varnish Works, 816 Mission St., San Francisco.
 Fifteen for Floors, made by W. P. Fuller & Co., San Francisco.
 Standard Varnish Works, Chicago, New York and San Francisco.
 R. N. Nason & Co., San Francisco and Los Angeles.
- FLOORS—HARDWOOD**
 Oak Flooring Manufacturers' Association of the United States, Ashland Block, Chicago, Ill.
- Parrott & Co., 320 California St., San Francisco.
 White Bros., Fifth and Brannan Sts., San Francisco.
 Strable Hardwood Company, 511 First street, Oakland.
- FLOORS—MASTIC**
 Hill, Hubbell & Company, No. 1 Drumm St., San Francisco.
- FLOORS—DUST PROOF CEMENT**
 L. Sonneborn Co., United Materials Co., San Francisco agents.
- FLUMES**
 California Corrugated Culvert Co., West Berkeley, Cal.
- FLUSH VALVES**
 National Valve Company, 23-25 Minna St., San Francisco.
- FRUIT DRYING MACHINERY**
 Ideal Heating & Engineering Co., 192 Erie St., San Francisco.
 Jas. A. Nelson, 517 Sixth St., San Francisco.
- FUEL OIL SYSTEMS**
 S. T. Johnson Co., 1337 Mission St., San Francisco.
 S. F. Bowser & Co., Inc., 612 Howard St., San Francisco.
 Wayne Oil Tank & Pump Co., 631 Howard St., San Francisco.
- FURNACES—WARM AIR**
 Mangrum & Otter, 827 Mission St., San Francisco.
 Montague Range and Furnace Co., 826 Mission St., San Francisco.
- FURNITURE—BUILT-IN**
 Hoosier Kitchen Cabinet Store, Pacific Bldg., San Francisco.
- FURNITURE—SCHOOL, CHURCH, OFFICE, HOUSE, ETC.**
 Home Manufacturing Company, 543 Brannan St., San Francisco.
 C. F. Weber & Co., 985 Market St., San Francisco.
 Rucker-Fuller Desk Co., 677 Mission St., San Francisco.
 F. W. Wentworth & Co., 539 Market St., San Francisco.
 W. & J. Sloane, 216-228 Sutter St., San Francisco.
- GALVANIZED IRON WORK**
 James A. Nelson, 517 Sixth St., San Francisco.
- GARAGE HARDWARE**
 The Stanley Works, New Britain, Conn., represented in San Francisco, Los Angeles, Seattle by John T. Rowntree, Inc.
 Richards-Wilcox Mfg. Co., Aurora, Ill., and Underwood Bldg., San Francisco.
- GARBAGE CHUTES AND INCINERATORS**
 Kerner Incinerator Co., 77 O'Farrell St., San Francisco.
 California Hydraulic Engineering & Supply Co., 70-72 Fremont St., San Francisco.
- GAS STEAM RADIATORS—FUMELESS, ETC.**
 Clow Gas Steam Radiators, F. A. Hamilton, Agent, 101 Rialto Bldg., San Francisco.

ROBERTSON PROCESS METAL FOR ROOFING AND SIDING

HH ROBERTSON CO
 BUILDING PRODUCTS

FORMERLY ASBESTOS PROTECTED METAL COMPANY

Hobart Building, San Francisco

Phone Garfield 522

When writing to Advertisers please mention this magazine.

DIECKMANN HARDWOOD COMPANY

Office, Mill, Yards, and Dry Kilns
BEACH AND TAYLOR STS.
 SAN FRANCISCO, CAL.
 PHONE FRANKLIN 2302

**Foreign & Domestic
 CABINET WOODS**

ARCHITECTS' SPECIFICATION INDEX—Continued

- GAS STEAM RADIATORS, ETC.**—Continued.
 Ra-Do Fumeless Gas Radiators, manufactured and sold by Baird-Bailhache Co., 478 Sutter St., San Francisco.
- GLASS**
 American Window Glass Co., represented by L. H. Butcher Co., 341 Montgomery St., San Francisco.
 Cobblelick-Kibbe Glass Co., 175 Jessie St., San Francisco.
 Fuller & Goepf, 32 Page St., San Francisco.
 W. P. Fuller & Company, all principal Coast cities.
- GRADING, WRECKING, ETC.**
 Dolan Wrecking & Construction Co., 1607 Market St., San Francisco.
- GRANITE**
 California Granite Co., Gen. Contractors' Ass'n, San Francisco.
 Raymond Granite Co., Potrero Ave. and Division St., San Francisco.
- GRAVEL AND SAND**
 Coast Rock & Gravel Co., Call-Post Bldg., San Francisco.
 Del Monte White Sand, sold by Del Monte Properties Co., Crocker Bldg., San Francisco.
- GYMNASIUM EQUIPMENT**
 Ellery Arms Co., 583 Market St., San Francisco.
 A. G. Spalding & Bros., 158 Geary St., San Francisco.
- HARDWALL PLASTER**
 Henry Cowell Lime & Cement Co., San Francisco.
- HARDWARE**
 Joost Bros., agents for Russell & Erwin hardware, 1053 Market St., San Francisco.
 The Stanley Works, New Britain, Conn.; Coast sales offices, San Francisco, Los Angeles, and Seattle, Wash.
 Corbin hardware, sold by Palacc Hardware Co., 581 Market St., San Francisco.
 Richards-Wilcox Mfg. Co., Aurora, Ill., Ewing-Lewis Co., 626 Underwood Bldg., San Francisco.
- HARDWOOD LUMBER—FLOORING, ETC.**
 Dieckmann Hardwood Company, Beach and Taylor Sts., San Francisco. (See advertisement above.)
 Inlaid Floor Co., 600 Alabama St., San Francisco.
 H. N. McNab, 2307 17th Ave., Oakland.
 Parrott & Co., 320 California St., San Francisco.
 White Bros., cor. Fifth and Brannan Sts., San Francisco.
 Strable Hardwood Company, First street, near Broadway, Oakland.
- HEATERS—AUTOMATIC—GAS**
 Pittsburg Water Heater Co., 478 Sutter St., San Francisco.
 George H. Tay Company, Mission and Second Sts., San Francisco; 10th and Harrison Sts., Oakland.
 Ra-Do Fumeless Gas Heater, sold by Baird-Bailhache Company, 478 Sutter St., San Francisco.
- HEATING AND VENTILATING MATERIAL, ETC.**
 Alex Coleman, 706 Ellis St., San Francisco.
- C. A. Dunham Co., Sheldon Building, San Francisco.
 Gilley-Schmid Company, 198 Otis St., San Francisco.
 Hateley & Hateley, Mitau Bldg., Sacramento.
 Knittle-Cashel Co., Inc., 1820 Ellis St., San Francisco.
 General Boilers Co., 332 Monadnock Bldg., San Francisco.
 Mangrum & Otter, 827-831 Mission St., San Francisco.
 Moline Heat, Hobart Bldg., San Francisco.
 James & Drucker, 450 Hayes St., San Francisco.
 James A. Nelson, 517 Sixth St., San Francisco.
 Ideal Heating & Engineering Co., 192 Erie St., San Francisco.
 Illinois Engineering Co., 563 Pacific Bldg., San Francisco.
 William F. Wilson Co., 328 Mason St., San Francisco.
 Pacific Fire Extinguisher Co., 424 Howard St., San Francisco.
 Scott Company, 243 Minna St., San Francisco.
 Mechanical Engineering & Supply Co., 908 7th St., Sacramento.
 George H. Tay Company, Mission and Second Sts., San Francisco; 10th and Harrison Sts., Oakland.
 O. M. Simmons Co., 115 Mission St., San Francisco.
- HOLLOW TILE BLOCKS**
 Cannon & Co., plant at Sacramento; office in Chronicle Bldg., San Francisco.
 Gladding, McBean & Co., San Francisco, Los Angeles, Oakland and Sacramento.
 Los Angeles Pressed Brick Co., Frost Bldg., Los Angeles.
 California Brick Company, 604 Mission street, San Francisco.
 Livermore Fire Brick Works, 604 Mission street, San Francisco.
- HOSPITAL FIXTURES**
 Mott Company of California, 553 Mission St., San Francisco.
 George H. Tay Company, Mission and Second Sts., San Francisco; 10th and Harrison Sts., Oakland.
- HOSPITAL SIGNAL SYSTEM**
 Chicago Signal Co., represented by Garnett, Young & Co., 612 Howard St., San Francisco.
- HOTELS**
 St. Francis Hotel, Powell, Geary and Post Sts., San Francisco.
- INGOT IRON**
 "Armo" brand, manufactured by American Rolling Mill Company, Middletown, Ohio, and 10th and Bryant streets, San Francisco.
- INSPECTIONS AND TESTS**
 Robert W. Hunt & Co., 251 Kearny St., San Francisco.
- INSULATION**
 American Insulux Company, Berkeley Bank building, Berkeley.
- INCINERATORS**
 Kerner Incinerator Co., 77 O'Farrell St., San Francisco.

"The Perfect Automatic Valve"

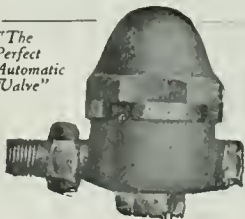

Haines Heating Systems

ASSURE

Heating Satisfaction

O. M. SIMMONS CO.

115 Mission St., San Francisco
 Phone: Douglas 5497

CLARENCE E. MUSTO. Pres.

JOSEPH B. KEENAN. Vice-Pres.

GUIDO J. MUSTO. Sec'y & Treas.

JOSEPH MUSTO SONS-KEENAN CO.Phone Franklin
—6365—**MARBLE**OFFICE AND MILLS:
535-565 North Point St.,
SAN FRANCISCO, CAL.**ARCHITECTS' SPECIFICATION INDEX—Continued****INTERIOR DECORATORS**

Beach-Robinson Co., 239 Geary St., San Francisco.
 Arthur Brown, 212 Foxcroft Bldg., San Francisco.
 John Breuner Co., 281 Geary St., San Francisco.
 Sonnenschein Bros., 470 Sutter St., San Francisco.
 The Tormey Co., 1042 Larkin St., San Francisco.
 Taylor Galleries, 1818 Harrison street, Oakland and San Francisco.
 Freeman Art Shop, 386 Sutter St., San Francisco.
 W. & J. Sloane, 216 Sutter St., San Francisco.

KITCHEN CABINETS

Hoosier Kitchen Cabinet Store (O. K. Brown, Mgr.), Pacific Bldg., San Francisco.

KITCHEN EQUIPMENT

James A. Nelson, 517-19 Sixth street, San Francisco.

LAMP POSTS, ELECTROLIERS, ETC.

J. L. Mott Iron Works, 553 Mission St., San Francisco.

LANDSCAPE GARDENERS

MacRorie-McLaren Co., 141 Powell St., San Francisco.

LATHING AND PLASTERING

MacGruer & Simpson, Call-Post Bldg., San Francisco.
 A. Knowles, Call-Post Bldg., San Francisco.
 Jas. F. Smith, 273 Minna St., San Francisco.

LATHING MATERIAL

Pacific Materials Co., 525 Market St., San Francisco.
 Key-Hold Plaster Lath Co., 148 Hooper St., San Francisco.
 Truscon Steel Co., Tenth St., near Bryant, San Francisco.

LIGHT, HEAT AND POWER

Great Western Power Company, Stockton St., near Sutter, San Francisco.

LIGHTING FIXTURES

Roberts Mfg. Co., 663 Mission St., San Francisco.
 Perfecite Manufacturing Co., Seattle, Wash.; San Francisco Representatives, Myers & Schwartz, 75 New Montgomery street, San Francisco; 1119 S. Los Angeles street, Los Angeles.

LIME

Henry Cowell Lime & Cement Co., 2 Market St., San Francisco.

LINOLEUM

D. N. & E. Walter & Co., 562 Mission St., San Francisco.
 The Paraffine Companies, factory in Oakland; office, 34 First St., near Market, San Francisco.

W. & J. Sloane, 216-228 Sutter St., San Francisco.

LUBRICATING OIL STORAGE TANKS AND PUMPS

S. F. Bowser & Co., Inc., 612 Howard St., San Francisco

LUMBER

California Redwood Association, 216 Pine St., San Francisco.
 Dudfield Lumber Co., Palo Alto, Cal.

Hart-Wood Lumber Co., Fifth and Berry Sts., San Francisco.

Pacific Manufacturing Company, San Francisco, Oakland and Santa Clara.

Pope & Talbot, foot of Third St., San Francisco.

Portland Lumber Co., 16 California St., San Francisco.

Sunset Lumber Company, First and Oak Sts., Oakland.

MAIL CHUTES

American Mailing Device Corp., represented on Pacific Coast by Waterhouse-Wilcox Co., 523 Market St., San Francisco.

MANTELS

Mangrum & Otter, 827-831 Mission St., San Francisco.

California Brick Company, 604 Mission street, San Francisco.

MANUAL TRAINING EQUIPMENT

Richards-Wilcox Mfg. Co., Ewing-Lewis Co., 626 Underwood Bldg., San Francisco.
 Smith-Booth-Usher Co., San Francisco and Los Angeles.

MARBLE

American Marble and Mosaic Co., 25 Columbus Square, San Francisco.

Joseph Musto Sons, Keenan Co., 535 N. Point St., San Francisco.

Vermont Marble Co., Coast branches, San Francisco, Portland and Tacoma.

METAL DOORS AND WINDOWS

Fire Protection Products Co., 3117 20th St., San Francisco.
 Waterhouse-Wilcox Co., Inc., 523 Market St., San Francisco.
 U. S. Metal Products Co., 330 Tenth St., San Francisco.

MILL WORK

Dudfield Lumber Co., Palo Alto, Cal.
 Pacific Manufacturing Company, San Francisco, Oakland and Santa Clara.
 National Mill and Lumber Co., San Francisco and Oakland.

The Fink & Schindler Co., 218 13th St., San Francisco.

Frank Portman, 1619-20 Mission St., San Francisco.

MOTORS AND FANS

R. J. Davis, Dist. Sales Agent Century Motors and Fans, 171 Second St., San Francisco.

OIL BURNERS

American Standard Oil Burner Company, Berkeley.

Fess System Co., 220 Natoma St., San Francisco.

S. T. Johnson Co., 1337 Mission St., San Francisco.

T. P. Jarvis Manufacturing Co., 275 Connecticut St., San Francisco.

W. S. Ray Mfg. Co., 29 Spear St., San Francisco.

G. E. Witt Co., 862 Howard St., San Francisco.

OIL STORAGE AND DISTRIBUTING STATIONS

S. F. Bowser & Co., Inc., 612 Howard St., San Francisco.

S. T. Johnson Co., 1337 Mission St., San Francisco.

KNITTLE-CASHEL CO., Inc.**HEATING CONTRACTORS**STEAM HEATING
HOT WATER HEATINGVENTILATING
POWER PLANTSGENERAL PIPE WORK
REPAIRING

1820-22 Ellis Street, San Francisco

Phone West 964



On Your Best Work Specify

CAL-PA-CO DAMPSTOP (Outside)
WASHABLE WALL (Inside)
FOR CONCRETE BUILDINGS. *Everything Reliable in PAINT and VARNISH*

CALIFORNIA PAINT COMPANY, OAKLAND, CALIF., U. S. A.
MANUFACTURERS SINCE 1865 SAN FRANCISCO OFFICE, MONADNOCK BUILDING

ARCHITECTS' SPECIFICATION INDEX—Continued

- Wayne Oil Tank & Pump Co., 631 Howard St., San Francisco; 830 S. Los Angeles St., Los Angeles.
- OFFICE EQUIPMENT**
C. F. Weber Co., 985 Market St., San Francisco.
Rucker-Fuller Co., 677 Mission St., San Francisco.
- F. W. Wentworth & Co., 539 Market St., San Francisco.
- ORNAMENTAL IRON AND BRONZE**
California Artistic Metal and Wire Co., 349 Seventh St., San Francisco.
Palm Iron & Bridge Works, Sacramento.
C. J. Hillard Company, Inc., 19th and Minnesota Sts., San Francisco.
- ORNAMENTAL IRON AND BRONZE.—Cont.**
Schrader Iron Works, Inc., 1247 Harrison St., San Francisco.
- OVERHEAD CARRYING SYSTEMS**
California Hydraulic Engineering & Supply Co., 70-72 Fremont St., San Francisco.
Richards-Wilcox Mfg. Co., Aurora, Ill., and Underwood Bldg., San Francisco.
- PAINT FOR STEEL STRUCTURES, BRIDGES, ETC.**
The Paraffine Companies, Inc., 34 First St., San Francisco.
Premier Graphite Paint and Pioneer Brand Red Lead, made by W. P. Fuller & Co., San Francisco.
Hill, Hubbell & Company, No. 1 Drumm St., San Francisco.
Wadsworth, Howland Co., makers of Bay State Brick and Cement Coating, Boston, Mass.
Hambley & Son, Distributors in San Francisco and Los Angeles.
- PAINTING, TINTING, ETC.**
I. R. Kissel, 1747 Sacramento St., San Francisco.
D. Zelinsky & Sons, San Francisco and Los Angeles.
The Tormey Co., 681 Geary St., San Francisco.
Pick Bros., 475 Haight St., San Francisco.
Pacific Painting and Roofing Co., Pacific building, San Francisco; and 388 12th street Oakland.
- PAINTS, OILS, ETC.**
California Paint Company (see advertisement above).
Magner Bros., 414-424 Ninth St., San Francisco.
Bass-Hueter Paint Co., Mission, near Fourth St., San Francisco and all principal coast cities.
R. N. Nason & Company, San Francisco, Los Angeles, Portland and Seattle.
Ronfle Company, Pacific building, San Francisco; and 388 12th street, Oakland.
W. P. Fuller & Co., all principal Coast cities.
"Satinette," Standard Varnish Works, 55 Stevenson St., San Francisco.
Palace Hardware Co., 581 Market St., San Francisco.
- PANELS AND VENEER**
White Bros., Fifth and Brannan Sts., San Francisco.
- PARTITIONS—FOLDING AND ROLLING**
J. G. Wilson Corporation, 600 Metropolitan Bldg., Los Angeles; Waterhouse-Wilcox Co., Underwood Bldg., San Francisco.
- PENCILS**
Eberhard Faber, Monadnock Bldg., San Francisco.
- PIPE—STEEL AND WROUGHT IRON**
Western Pipe & Steel Co., 444 Market St., San Francisco; 1758 N. Broadway, Los Angeles.
George H. Tay Company, Mission and Second Sts., San Francisco; 10th and Harrison Sts., Oakland.
- PLAYGROUND EQUIPMENT**
A. G. Spalding & Bros., 158 Geary St., San Francisco.
- PLUMBING CONTRACTORS**
Alex Coleman, 706 Ellis St., San Francisco.
Gilley-Schmid Company 198 Otis St., San Francisco
Hateley & Hateley, Mitau Bldg., Sacramento.
Scott Co., Inc., 243 Minna St., San Francisco.
Wm. F. Wilson Co., 328 Mason St., San Francisco.
- PLUMBING FIXTURES, MATERIALS, ETC.**
California Steam & Plumbing Supply Co., 671 Fifth St., San Francisco.
Jas. B. Clow, plumbing, Rialto Bldg., San Francisco.
Crane Co., San Francisco, Oakland, Los Angeles.
Gilley-Schmid Company, 198 Otis St., San Francisco.
Haines, Jones & Cadbury Co., 857 Folsom St., San Francisco.
H. Mueller Manufacturing Company, 635 Mission St., San Francisco.
Holbrook, Merrill & Stetson, 64 Sutter St., San Francisco.
J. L. Mott Iron Works, D. H. Gulick, selling agent, 553 Mission St., San Francisco.
National Valve Company, 23-25 Minna St., San Francisco.
Pacific Sanitary Manufacturing Co., 67 New Montgomery St., San Francisco.
George H. Tay Company, Mission and Second Sts., San Francisco; 10th and Harrison Sts., Oakland.
West Coast Porcelain Manufacturers, Rialto building, San Francisco.
Wm. F. Wilson Co., 328 Mason St., San Francisco.
- POWER PLANTS**
Knittle-Cashel Co., Inc., 1820 Ellis St., San Francisco.
- POWER TRANSMITTING MACHINERY**
Meese & Gottfried, San Francisco, Los Angeles, Portland, Ore., and Seattle, Wash.
- PUMPS**
Chicago Pump Co., represented by Garnett, Young & Co., 612 Howard St., San Francisco.
California Hydraulic Engineering & Supply Co., 70 Fremont St., San Francisco.
Simonds Machinery Co., 117 New Montgomery St., San Francisco.
Ocean Shore Iron Works, 558 Eighth St., San Francisco.
Pacific Pump & Supply Company, 851-853 Folsom St., San Francisco.
George H. Tay Company, Mission and Second Sts., San Francisco; 10th and Harrison Sts., Oakland.
- PUMPS—HAND OR POWER, FOR OIL AND GASOLINE**
S. F. Bowser & Co., Inc., 612 Howard St., San Francisco.

DUNN SPRAY METHOD OF PAINTING

Saves Time, Labor and Material Will outwear paint applied by other methods.
→ RONFLE Special Paints for Specific Purposes Used Unless Otherwise Specified.

PACIFIC PAINTING AND ROOFING COMPANY

G. D. NEWTON, Manager

PACIFIC BLDG., SAN FRANCISCO. 388-12th St., OAKLAND



Yards { TRACY, CAL.
BRENTWOOD, CAL.

Phone KEARNY 2074

PORTLAND LUMBER COMPANY

A. J. RUSSELL, Agent

LUMBER

SIMPLEX SILOS
SAGINAW SPECIAL SHINGLES
*Ship Timbers, Oil Rigs and
Special Bills Cut to Order.*

16 California Street

San Francisco, Cal.

from tree to Consumer

Pine and Redwood Lumber

SASH DOORS AND MILL WORK

SUNSET LUMBER COMPANY

MANUFACTURERS — WHOLESALE AND RETAIL

Main Office and Yards:

FIRST AND OAK STREETS, OAKLAND

Phone Oakland 1820

POPE & TALBOT

Manufacturers, Exporters and Dealers in

Lumber, Timber, Piles, Spars, etc.

Office, Yards and Planing Mills

859-869 THIRD ST., SAN FRANCISCO, CAL.

Mills, Port Gamble, Port Ludlow and Utsalady, Washington

PACIFIC MANUFACTURING COMPANY

MILLWORK, SASH AND DOORS

Hardwood Interior Trim a Specialty

Main Office:

SANTA CLARA, CALIF.

SAN FRANCISCO, 177 Stevenson Street
OAKLAND, 1001 Franklin Street

LOS ANGELES, 908 Washington Building
SAN JOSE, 16 North First Street

ARCHITECTS' SPECIFICATION INDEX—Continued

PUMPS (Continued)

- S. T. Johnson Co., 1337 Mission St., San Francisco.
 Wayne Oil Tank & Pump Co., 631 Howard St., San Francisco; 830 S. Los Angeles St., Los Angeles.
 George H. Tay Company, Mission and Second Sts., San Francisco; 10th and Harrison Sts., Oakland.

RADIATOR TRAPS

- C. A. Dunham Co., Sheldon Bldg., San Francisco.

REINFORCING STEEL

- Edward L. Soule, Rialto Building, San Francisco.
 Gunn, Carle & Co., Inc., 444 Market street, San Francisco.
 Pacific Coast Steel Co., Rialto Building, San Francisco.
 Truscon Steel Co., 527 10th St., San Francisco.

REFRIGERATORS

- McCray Refrigerator Company, San Francisco office, 765 Mission street.

REVERSIBLE WINDOWS

- Hauser Window Company, 157 Minna St., San Francisco.

ROOFING CONTRACTORS

- Bender Roofing Company, Monadnock Bldg., San Francisco.
 H. C. Brown Roofing Co., National Roofing Company, Pacific Roofing Co., C. G. Williams, A. K. Goodmundson, 2140 San Pablo Ave., Oakland.

ROOFING AND ROOFING MATERIALS

- "Malthoid" and "Ruberoid," manufactured by Paraffine Companies, Inc., San Francisco.
 United Materials Co., Crossley Bldg., San Francisco.
 H. H. Robertson Co., Hobart Bldg., San Francisco.
 California Brick Company, 604 Mission street, San Francisco.

RUBBER TILING

- New York Belting and Packing Company, 518 Mission St., San Francisco.

SAFETY TREADS

- Pacific Materials Co., 525 Market St., San Francisco.

SAND

- Del Monte White Sand, Del Monte Properties Co., 401 Crocker Bldg., San Francisco.

SASH CORD

- Samson Spot Sash Cord, John T. Rowntree, Pacific Coast Agent, San Francisco and Los Angeles.

SCENIC PAINTING—DROP CURTAINS, ETC.

- The Edwin H. Flagg Scenic Co., 1638 Long Beach Ave., Los Angeles.

SCHOOL FURNITURE AND SUPPLIES

- C. F. Weber & Co., 985 Market St., San Francisco; 512 S. Broadway, Los Angeles.
 Rucker-Fuller Desk Company, 677 Mission St., San Francisco.

SHEATHING AND SOUND DEADENING

- Samuel Cabot Mfg. Co., Boston, Mass., agencies in San Francisco, Oakland, Los Angeles, Portland, Tacoma and Spokane.
 The Paraffine Companies, Inc., 34 First St., San Francisco.

SHINGLE STAINS

- Bass-Hueter Paint Company, all principal Coast cities.
 Cabot's Creosote Stains, sold by Pacific Building Materials Co., 525 Market St., San Francisco.
 Fuller's Pioneer Shingle Stains, made by W. P. Fuller & Co., San Francisco.
 Argonaut Shingle Stains. The Glidden Co., 123 Hooper St., San Francisco.

SHINGLES—STONE

- McClenahan Products Co., Inc., 670 Howard St., San Francisco.

SINKS—COMPOSITION

- Petrium Sanitary Sink Co., Fifth and Page Sts., Berkeley.

SKYLIGHTS

- H. H. Robertson Co., Hobart Bldg., San Francisco.
 Jas. A. Nelson, 517 Sixth St., San Francisco.

STATIONERY AND SUPPLIES

- Schwabacher-Frey Stationery Co., 609 Market St., San Francisco.
 H. S. Crocker Co., 565 Market street, San Francisco.

STEEL HEATING BOILERS

- California Hydraulic Engineering & Supply Co., 70-72 Fremont St., San Francisco.
 General Boilers Co., 332 Monadnock Bldg., San Francisco.

STEEL TANKS, PIPE, ETC.

- Ocean Shore Iron Works, 558 Eighth St., San Francisco.
 S. T. Johnson Co., 1337 Mission St., San Francisco.

STEEL AND IRON—STRUCTURAL

- Central Iron Works, 621 Florida St., San Francisco.
 Golden Gate Iron Works, 1541 Howard St., San Francisco.
 Mortenson Construction Co., 19th and Indiana Sts., San Francisco.
 Pacific Rolling Mills, 17th and Mississippi Sts., San Francisco.
 Palm Iron & Bridge Works, Sacramento.
 U. S. Steel Products Co., Rialto Bldg., San Francisco.
 Schrader Iron Works, Inc., 1247 Harrison St., San Francisco.
 Western Iron Works, 141 Beale St., San Francisco.

STEEL PRESERVATIVES

- Hill, Hubble & Company, No. 1 Drumm St., San Francisco.

STEEL ROLLING DOORS

- Pacific Building Materials Co., Underwood Bldg., San Francisco.
 J. G. Wilson Corporation, 600 Metropolitan Bldg., Los Angeles.

STEEL SASH

- Bayley-Springfield solid steel sash, sold by Pacific Materials Co., 525 Market St., San Francisco.

- "Fenestra," solid steel sash, manufactured by Detroit Steel Products Company, Detroit, Mich. Direct factory sales office, Foxcroft Bldg., San Francisco.

- U. S. Metal Products Company, 330 Tenth St., San Francisco.
 Truscon Steel Company, 527 Tenth street, San Francisco.

STORE FRONTS

- The Kawncer Manufacturing Company, West Berkeley, California.

- Zouri Safety Sash Bars—Cobbledeick-Kibbe Glass Company, 175 Jessie St., San Francisco.

STUDDING—FIREPROOF STEEL

- Steel Studding Company, 1216 Folsom St., San Francisco.

SUMP AND BILGE PUMPS

- California Hydraulic Engineering & Supply Co., 70-72 Fremont St., San Francisco.

MOLINE HEAT

Hobart Building

San Francisco

TELEPHONE SUTTER 3818

ARCHITECTS' SPECIFICATION INDEX—Continued

SWITCHES

Wemco Safety Switch, manufactured and sold by W. E. Musket Co., 502 Mission St., San Francisco.

Western Electric Safety Switch Co., Inc., 247 Minna street, San Francisco.

TELEPHONE AND ELECTRIC EQUIPMENT

Direct Line Telephone Co., 320 Market St., San Francisco.

THEATER AND OPERA CHAIRS

C. F. Weber & Co., 365 Market St., San Francisco.

Rucker-Fuller Desk Co., 677 Mission St., San Francisco.

THERMOSTATS FOR HEAT REGULATION

Johnson Service, Rialto Bldg., San Francisco.

TILES, MOSAICS, MANTELS, ETC.

Mangrum & Otter, 827-831 Mission St., San Francisco.

TILE FOR ROOFS

Cannon & Co., Sacramento; and 77 O'Farrell St., San Francisco.

California Brick Company, 604 Mission street, San Francisco.

Gladding, McBean & Co., Crocker Bldg., San Francisco.

United Materials Co., Crossley Bldg., San Francisco.

TRANSMISSION MACHINERY

Meese & Gottfried Co., San Francisco, Los Angeles and Portland.

VACUUM CLEANERS

United Electric Company, Canton, O., manufacturers of Tucc Cleaners, sold in California by San Francisco Compressed Air Cleaning Co., Stockton and Sutter Sts., San Francisco.

VALVES—PIPES AND FITTINGS

California Steam & Plumbing Supply Co., 671 Fifth St., San Francisco.

Crane Radiator Valves, manufactured by Crane Co., Second and Brannan Sts., San Francisco.

National Valve Company, 23-25 Minna St., San Francisco.

Grinnell Co., 453 Mission St., San Francisco.

O. M. Simmons Co., 115 Mission St., San Francisco.

H. Mueller Mfg. Co., 635 Mission St., San Francisco.

W. E. Musket Co., 502 Mission St., San Francisco.

George H. Tay Company, Mission and Second Sts., San Francisco; 10th and Harrison Sts., Oakland.

VALVE PACKING

N. H. Cook Belting Co., 317 Howard St., San Francisco.

VARNISHES

Bass-Hueter Paint Company, Mission, near 4th street, San Francisco, and all principal coast cities.

California Paint Company, 1797 Twelfth St., Oakland.

W. P. Fuller Co., all principal Coast cities.

R. N. Nason & Co., San Francisco, Los Angeles, Portland and Seattle.

Standard Varnish Works, 55 Stevenson St., San Francisco.

VENETIAN BLINDS, AWNINGS, ETC.

C. F. Weber & Co., 985 Market St., San Francisco.

Western Blind & Screen Co., 2702 Long Beach Ave., Los Angeles.

VITREOUS CHINAWARE

Pacific Porcelain Ware Company, 67 New Montgomery St., San Francisco.

West Coast Porcelain Manufacturers, Rialto Building, San Francisco.

WALL BEDS, SEATS, ETC.

Marshall & Stearns Co., 1154 Phelan Bldg., San Francisco.

WALL BOARD

"Amiwud" Wall Board, manufactured by The Paraffine Companies, Inc., 34 First St., San Francisco.

"Liberty" Wall Board, manufactured by Key-Hold Plaster Lath Co., 148 Hooper St., San Francisco.

WALL PAINT

Nason's Opaque Flat Finish, manufactured by R. N. Nason & Co., San Francisco, Portland and Los Angeles.

San-A-Cote and Vel-va-Cote, manufactured by the Brininstool Co., Los Angeles.

WALL PAPER AND DRAPERIES

Arthur Brown, Foxcroft Bldg., San Francisco.

Beach-Robinson Co., 239 Geary St., San Francisco.

The Tormey Co., 681 Geary St., San Francisco.

W. & J. Sloane, 216-228 Sutter St., San Francisco.

Uhl Bros., San Francisco.

WATERPROOFING FOR CONCRETE, BRICK, ETC.

Armorite Damp Resisting Paint, made by W. P. Fuller & Co., San Francisco.

Bay State Brick & Cement Coating, manufactured by Wadsworth, Howland Co., Boston; Hambley & Son., Distributors for Northern and Southern California.

Gunn, Carle & Co., Inc., "Hydrate," 444 Market street, San Francisco.

Imperial Waterproofing, mfrd. by Brooks & Doerr, Reed Baxter, agent, Merchants National Bank Bldg., San Francisco.

Pacific Materials Co., 525 Market St., San Francisco.

Samuel Cabot Mfg. Co., Boston, Mass., agencies in San Francisco, Oakland, Los Angeles, Portland, Tacoma and Spokane.

WATER SUPPLY SYSTEMS

Kewanee Water Supply System—Simonds Machinery Co., agents, 117 New Montgomery St., San Francisco.

Pacific Pump & Supply Company, 851-853 Folsom St., San Francisco.

Smith-Booth-Usher Co., San Francisco and Los Angeles.

WATER HEATERS

Pittsburg Water Heater Co., 478 Sutter street, San Francisco.

WHEELBARROWS—STEEL

Western Iron Works, Beale and Main Sts., San Francisco.

WHITE CEMENT

"Medusa White," sold by Pacific Materials Co., Underwood Bldg., San Francisco.

WHITE ENAMEL

"Gold Seal," manufactured and sold by Bass-Hueter Paint Co. All principal Coast cities.

"Silkenwhite," made by W. P. Fuller & Co., San Francisco.

"Satinette," Standard Varnish Works, 55 Stevenson St., San Francisco.

WINDOW SHADES

W. & J. Sloane, 216-228 Sutter St., San Francisco.

WINDOW SASH CORD

Sampson Spot Cord, John T. Rowntree, Pacific Coast agents, San Francisco and Los Angeles.

WINDOWS, REVERSIBLE, CASEMENT, ETC.

Hauser Window Co., 157 Minna St., San Francisco.

The Kawneer Company, West Berkeley, California. (Simplex Fixtures.)

J. G. Wilson Corporation, 600 Metropolitan Bldg., Los Angeles; Waterhouse-Wilcox Co., Underwood Bldg., San Francisco.

WIRE FENCE

Standard Fence Co., 245 Market street, San Francisco; and 310 12th street, Oakland.

WOOD MANTELS

Fink & Schindler, 218 13th St., San Francisco.

Mangrum & Otter, 827 Mission St., San Francisco.

MOTT PLUMBING FIXTURES

Architects and their clients are invited to visit our Showrooms, 553-555 Mission Street, San Francisco; D. H. Gulick, Sales Agent. Los Angeles Office, 1001 Central Building; J. R. Mayhew, Sales Agent.

Mott Company of California

MUELLER — BRASS GOODS

Recognized as the Standard of excellence in plumbing. It pays to use them, and other **Mueller** Brass Goods. *The first cost is practically their last cost.*

H. Mueller Mfg. Co.

635 MISSION STREET, SAN FRANCISCO, CAL.

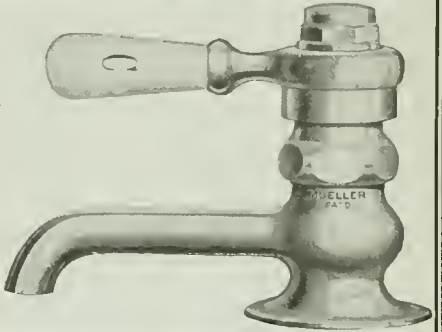

STORM KING and AMERICAN WARM AIR FURNACES

FURNACE FITTINGS AND REPAIRS

Montague Range & Furnace Company

327-329 JESSIE STREET

Phone Garfield 1422

826-830 MISSION STREET

SAN FRANCISCO, CALIF.

**DON'T NEGLECT YOUR HEATING SYSTEM.
THE BEST IS NONE TOO GOOD!**

All kinds of Galvanized Iron Work — Furnaces, Pipes, Ventilators — Sheet Metal for Planing Mills, Fruit Dryers, Rice Mills. Kitchen Equipment, including Steam Tables, Sinks, Canopies, Urn Stands, Etc.

JAMES A. NELSON

Heating and Ventilating Contractor

Phone, Garfield 1959

517-519 SIXTH ST., SAN FRANCISCO



Residence for Raymond C. Thorne Lexington Ave., Beverly Hills, Los Angeles
 Designed and Built by Frank Meline Co.

like the exquisite music of a dream ----

COMES the suggestion of dashing vaqueros and beautiful señoritas of by-gone days — when one perceives this modern home. Enough of the Spanish influence to render it distinctively appealing. Sufficient of tomorrow's trend to hold the attention.

HARMONY of design,—a delight to the physical and the aesthetic. In the finishing touches of this home, it became logically necessary to use products whose own manufacturing history recalls the days of the Spanish padres. Those of

W. P. FULLER & COMPANY

"Since '49"

PAINT MAKERS COLOR GRINDERS

SAN FRANCISCO

Oakland
 Stockton
 Sacramento

Los Angeles
 San Diego
 Santa Monica

Long Beach
 Pasadena
 Boise

Portland
 Spokane
 Tacoma
 Seattle

CHICAGO

Condensation Pumps
Sewage Ejectors
Bilge Pumps

PUMP COMPANY

Garnett Young and Company

Pacific Coast Sales Engineers

612 Howard Street, San Francisco

SEATTLE

LOS ANGELES

PORTLAND

WHY are so many architects — architects who discriminate—specifying DEL MONTE WHITE SAND?

The answer is to be found in the beautiful, soft white effect produced in stucco. Mixed with white cement the result is astonishing.

Del Monte White Sand and Fan Shell Beach Sand sold by leading building material dealers from Los Angeles to Vancouver, B. C. PROMPT DELIVERIES

Del Monte Properties Co.

Telephone Sutter 6130

401 Crocker Building, San Francisco

OAK FLOORS

(For Everlasting Economy)



In the Court of professional opinion American Oak versus Japanese Oak

IN specifying floors for the buildings you plan you owe it to your clients, as well as to yourself, to protect them against such penny-wise and pound-foolish policies as that of substituting cheaper but much inferior Japanese Oak for the genuine American product.

A thorough investigation will convince you that Japanese Oak does not compare with American in grain or flower, besides lacking its rugged strength and durability.

It will be found to be very porous, breaking off evenly instead of with jagged edges, thereby betraying to the expert its brashy nature. While the occurrence of soft boards makes it impossible to get an even surface and finish.

This trade-mark, stamped on every stick, is always a guarantee of *American-grown* Oak Flooring of the highest quality, which has been inspected in all processes of air seasoning, kiln drying, milling and grading by our own independent inspectors. Insist on this trade-mark.

Upon request we will mail booklets on Oak Flooring which contain much information of interest and value to you in the practice of your profession.



See page 389, SWEET'S
CATALOGUE, for speci-
fications of various grades.



OAK FLOORING MFRS. ASSN.
1036 Ashland Block Chicago, Illinois





Brininstool

San - a - Cote

(GLOSS—Can be Scrubbed)

AN INTERIOR WALL FINISH

For bath rooms, kitchens, hospitals, schools, office and public buildings. Ask dealers, owners, architects and contractors about this durable, sanitary, washable, economical wall covering. Brininstool makes a paint for every purpose, and every can purposely good.

THE BRININSTOOL CO., LOS ANGELES

COLOR GRINDERS AND PAINT MANUFACTURERS

Distributors—The Brininstool Co., 1174 Phelan Bldg., San Francisco, Cal.; The Brininstool Co., 222 Abington Bldg., Portland, Ore.; Schutz Paint Co., Fresno, Cal.; Schneider, Chappell & Jones, Sacramento, Cal.; Salt Lake Glass & Paint Co., Salt Lake City, Utah; Griffin Paint Co., Ogden, Utah; Campbell Hardware Co., First and Madison Sts., Seattle, Wash.; Imperial Valley Hardware Co., El Centro, Calexico, Imperial, Brawley, Seeley, Cal.; Spokane Hardware Co., Spokane, Wash.; Continental Paint Company, 328 South First St., San Jose, Cal.; Los Angeles Wallpaper & Paint Co., 525 So. Main St., Los Angeles, Cal.; H. A. Berger, 3838 13th St., San Diego, Cal.; H. L. Christian, Elythe, Cal.; Ezra Thayer, Phoenix, Ariz.; Miami Lumber & Supply Co., Miami, Ariz.

RELIANCE BALL BEARING DOOR HANGERS

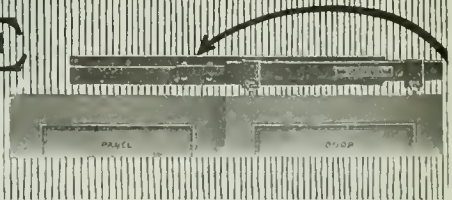

To get as near perfection as possible, use

RELIANCE "HANGERS" and "Reliance-Grant" Controllers

These insure fast service, practically noiseless and slamless doors.

Reliance-Grant Elevator Equipment Corp'n

PARK AVENUE AND 40TH STREET, NEW YORK

PACIFIC COAST AGENTS

Waterhouse-Wilcox Co.	San Francisco and Los Angeles, Cal.
Columbia Wire & Iron Works	Portland, Ore.
D. E. Fryer & Company	Seattle, Spokane, Tacoma, Wash. and Great Falls, Mont.

Insulex



This new heat insulation not only excels in durability and efficiency as a steam pipe covering but is especially adaptable to refrigeration practice.

AMERICAN INSULEX COMPANY

204 BERKELEY BANK BUILDING, BERKELEY

Phone Berkeley 641



Grace Evangelical Lutheran Church, Wadsworth, Ohio. Mr. Reynold H. Hinsdale, Cleveland, Architect; Artstone furnished by The George Rackle & Sons Co., Cleveland, using Medusa Stainless White Cement. Waterproofed.

“Medusa” Trim Adds Distinction

THIS interesting edifice, in French Gothic design, strikes a note of good taste very often missed in the buildings in our smaller cities and towns. The contrast afforded by the fresh, white Artstone finish (made from Medusa Stainless White Cement and suitable aggregates) against the tapestry brick, is distinctive, yet restrained and pleasing.

The use of Medusa Waterproofed Stainless White Cement is assurance to architect and congregation that the finish will not only repel moisture permanently, but that even many years' exposure will not cause the trim to discolor or change texture.

The Medusa Booklets will gladly be sent on request.

THE SANDUSKY CEMENT COMPANY,
Department P CLEVELAND, OHIO

MANUFACTURERS OF MEDUSA STAINLESS WHITE CEMENT (PLAIN OR WATERPROOFED) AND MEDUSA WATERPROOFING (POWDER OR PASTE)

PACIFIC COAST DISTRIBUTORS:

Pacific Materials Co., San Francisco, Cal. Riverside Portland Cement Co., Los Angeles, Cal. A. McMillan & Co., Portland, Ore. Galbraith & Co., Seattle, Wash.



The interior is done in quartered oak; Caen stone walls with Artstone trimming. Aisle and vestibule floors of Faence tile; Chancel floor of Grey Tennessee Marble. The altar is of White Vermont Marble.

The "MEDUSA REVIEW" deals with problems of architect, engineer, contractor and dealer, and shows various applications of cement in construction work of various kinds. We shall be pleased to enter your name upon request. The subscription is free.

MEDUSA Stainless White Cement - Waterproofed

CANNON & CO.

Clay Products

Denison Interlocking Tile

Face Brick

Hollow Tile

Roof and Floor Tile

OFFICE:

Building Material Exhibit, 77 O'Farrell St., San Francisco

Telephone Sutter 5333

Factory and General Offices:

Sacramento, California

GENERAL BOILERS COMPANY

DEPARTMENT OF SALES

A. W. MERRILL, Manager

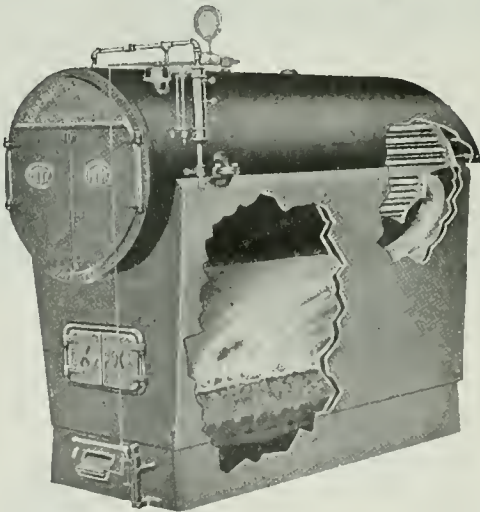

MANUFACTURERS of
 Pacific Patented Steel
 Portable Double Return Tube
 — Low Pressure Steam and
 Hot Water Heating Boilers
 — Pacific Steel Circulating
 Tanks — Pacific Steel Tank
 Heaters and Storage Tanks.

General Office and Plant:
 WAUKEGAN, ILLS.

Sales Offices: 322 Monadnock Building, San Francisco and 1310 South Hill St.,
 Los Angeles, California.



LINOTOL

PLASTIC FLOORING
THAT LASTS

*The Floor for
Office and
Showroom*

THE designing of office and store interiors, finish and decoration, especially in the matter of flooring, is receiving increasing attention from architects and builders.

For years Linotol has been used as a floor on fine passenger ships, and has given entire satisfaction. It is now being very generally used in high class offices and places where appearance as well as economy is an important factor.

It is light in weight, beautiful in finish, and practically indestructible. It can be furnished in any variety of designs and color schemes. It is water-tight, fire-proof, and will outlast the building.

*Let our representative tell you
more about Linotol. He will be
glad to call at your convenience.*

HILL, HUBBELL & COMPANY

Manufacturers and Contractors · 1 Drumm Street

San Francisco

LOS ANGELES
410 San Fernando Bldg.

NEW YORK
N. Y.

SEATTLE
209 Grand Trunk Pacific Dock

How daylight helps workmen do more and better work

DAYLIGHT and fresh air are powerful aids to production. The stimulus of plenty of light and fresh air is reflected in greater volume and accuracy of output, with diminished wastage. Operatives enjoy better health, are freer from eye-strain, lose fewer days through sickness. Labor turnover is reduced—output is noticeably increased. All of this is accomplished with TRUSCON Daylight Sash.

Truscon Daylight Engineers at your Service

All sizes of Truscon Steel Sash carried in stock in San Francisco Warehouse.

Largest stock of fireproof material and reinforcing bars on the Pacific Coast.

TRUSCON STEEL COMPANY

CHAS. HOLLOWAY, JR., Branch Manager

527 Tenth Street, San Francisco

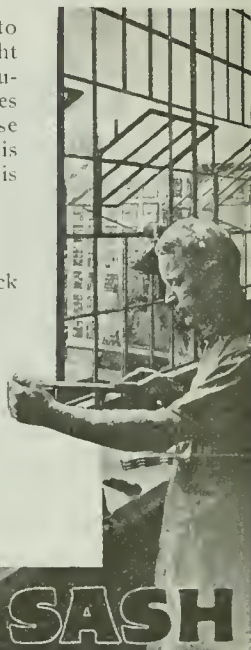

TRUSCON DAYLIGHT SASH

Ford

Whether for commercial purposes or pleasure, the Ford car will answer any requirement. It has proven its worth in every field of endeavor.

For eighteen years we have catered to the wants of the Ford buying public.

We can offer you the benefits of that long experience by giving you the acme of service through our coastwise organization.

William L. Hughson Co.

Since 1903

Geary at Van Ness, San Francisco

Prospect 607



Seattle

Portland

Oakland

Los Angeles

San Diego



**THE HOUSE
BEAUTIFUL**



THE interior of a Home should have those little touches of refinement that come with the co-operation of an experienced interior decorator.

CONSULT US

Decorative ideas, artistic framing, byamopa ware, floor lamps, table lamps, chair lamps, lamp shades, mirrors, candlesticks, decorated candles, book-ends, store window fixtures, odd furniture, pictures, Emma B. Freeman's Prints, pieces in unique colorings and indefinite carvings and other objects of art.

FREEMAN ART SHOP

386 SUTTER STREET
SAN FRANCISCO

Tel. Sutter 1593



Beach-Robinson Co.

Decorators and Furnishers

Carpets

Draperies

Furniture

Rugs

Wall Paper

Ranson E. Beach

239 Geary Street, 3d Floor

Union Square

Phone, Sutter 580

San Francisco, Cal.



ADD CHEER and COMFORT

to the Home by having a

WELL DESIGNED INTERIOR

Before Completing Your Plans, CONSULT

SONNENSCHN BROS.

INTERIOR DECORATORS

Furniture and Draperies Made to Order

Factory

718 NATOMA ST., Phone Market 1145

Show and Salesroom

470 SUTTER ST., Phone Kearny 2051

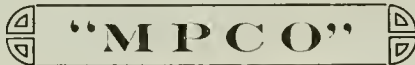

LIGHT WEIGHT
FIREPROOF
EVERLASTING

STONE SHINGLES

McCLENAHAN
PRODUCTS
COMPANY

VARIETY
and
DURABILITY
of COLORS

670 Howard St.

INC.

San Francisco

The **GOLD MEDAL
MAIL CHUTE**



INSTALLED IN
THE NEW
SAN FRANCISCO
CITY HALL
AND THE
WHITE MARBLE
MERRITT
BUILDING,
LOS ANGELES

Given highest award at
Panama - Pacific Interna-
tional Exposition, 1915.

Waterhouse-Wilcox Co.

California
Representatives

523 Market Street
SAN FRANCISCO

331 E. 4th Street.
LOS ANGELES

F. T. CROWE & CO.
Seattle, Wash.

THE J. McCracken Co.
Portland, Oregon

**American Mailing
Device
Corporation**

**LIBERTY
WALL BOARD**

MANUFACTURED BY
KEY-HOLD PLASTER LATH COMPANY



A Fibered Gypsum Plaster that will not
shrink, warp or buckle.
Resists Fire, Moisture, Heat and Cold.
Key-hold plaster lath possesses a perfect
mechanical key—admitted for fire proof con-
struction in all classes of buildings.

KEY-HOLD PLASTER LATH CO.

Office and Factory

148 Hooper St. San Francisco
Phone Market S767

McCRAY
**REFRIGERATORS
FOR ALL PURPOSES**

It is our particular desire to
impress the Architects of
America with the fact that
McCray builds refrigerators
for all purposes. Thousands
of fine residences, hotels,
clubs, restaurants, factory
cafeterias, hospitals, stores and
markets depend on McCray
for efficient, economical re-
frigerator service.

McCRAY REFRIGERATOR CO.
765 Mission Street, San Francisco, Calif.
Home Office and Factory
Kendallville, Ind

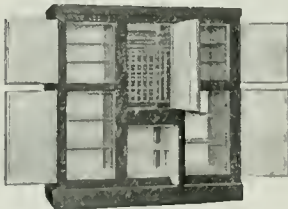

YOU KNOW that a building
should be watertight and
WE KNOW that it can be
made so with

**IMPERIAL
WATERPROOFING**

LOOK FOR  THE LABEL

If your building is leaking through
the walls or around the windows, or
if the Basement walls are wet below
ground— call up **SUTTER 978.**

IMPERIAL WATERPROOFING
is manufactured by **BROOKS &
DOERR, 460 7th St., San Francisco**

**WATEREX REED BAXTER
DISTRIBUTOR**

1002-04 Merchants National Bank Building,
Phone Sutter 978
SAN FRANCISCO, CAL.
3419 Broadway, **OAKLAND, CAL.**

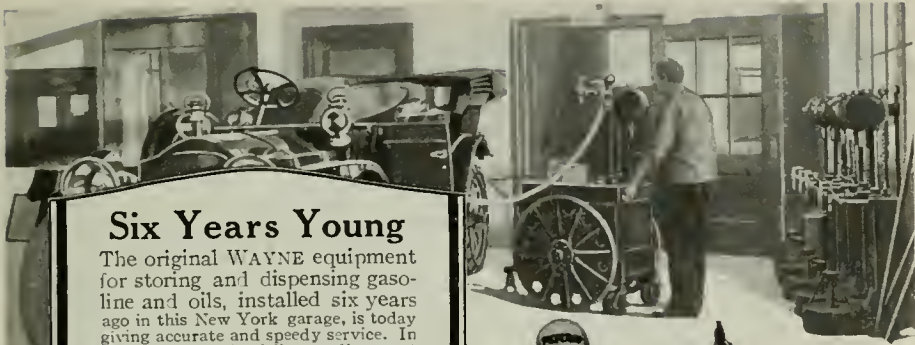

Six Years Young

The original WAYNE equipment for storing and dispensing gasoline and oils, installed six years ago in this New York garage, is today giving accurate and speedy service. In Wayne pumps the delicate adjustment essential for accuracy is combined with a durability that assures satisfaction for years and years.

There is a Wayne System for every need of the public garage. The service of Wayne engineers in advising and planning is yours without cost or obligation.

Wayne Oil Tank & Pump Co.
746 Canal St., Ft. Wayne, Ind.

San Francisco Office
631-633 Howard St.
Phone Garfield 1350

Los Angeles Office
830 S. Los Angeles St.
Phone Main 1600

REG. U.S. PAT. OFF. & TRADE MARK
Wayne
Liquid Storage Systems



Cut No. 230 For Gas and Oil



Cut No. 280 One-gallon gasoline



Cut No. 200 Lubricating oils



THE J. S. HAWLEY RESIDENCE, BERKELEY JAS. W. PLACHEK, Architect

Noiseless, smooth-sliding Door Hangers are a delight to the housewife. Architects who seek to please their clients know this and that's why they specify PITCHER DOOR HANGERS.

NATIONAL MILL & LUMBER COMPANY

318 Market Street, San Francisco

Mills in Alameda

Phone Kearny 3626

Warehouse in San Francisco

THE AMERICAN ART METAL WORKS
 EXECUTORS
 OF
 HIGH GRADE WORK
 IN
 BRONZE BRASS
 IRON & COMPO

13 GRACE ST. SAN FRANCISCO PHONE MKT. 1404

ARTISANS IN ORNAMENTAL METAL WORK TO SPECIAL DESIGN	ARCHITECTURAL DECORATIVE SCULPTURAL
---	---

WE MAKE THE FOLLOWING:

Sculptured Bronze Entrance Doors, Bank
 Counters, Bronze Mausoleum Doors, Ecclesi-
 astical Metal Work, Bronze and Iron Stair
 Railings, Crematory Urns, Memorial Tablets,
 Signs and Separate Bronze Letters, Statues,
 Figures, Portraits, Busts, Medallions, Monu-
 mental Bronze Work, Fountains, Sun-dials,
 Vases, Bulletin Boards, Mantels, Andirons,
 Artistic Heating and Ventilating Registers,
 Electric Light Standards, Cast Bronze and
 Iron Lanterns, Chandeliers in Bronze, Brass,
 Iron and Compo.

GOLD, SILVER, NICKEL, COPPER AND
 BRASS PLATING

We are at all times pleased to correspond
 with parties interested in our products.

We will be pleased to quote prices on any
 designs which are submitted to us.

AMERICAN ART METAL WORKS
 13 GRACE ST. PHONE MKT. 1404 SAN FRANCISCO



The **DUNHAM** HEATING SERVICE

Every *DUNHAM* Trap is Tested

Every Dunham Radiator Trap is permanently adjusted at the factory: it never needs attention in service when used within the range of pressure for which it was designed. Then, *after that*, each individual trap is tested, as illustrated, to prove that it opens for air and water but closes tight against steam.

There is nothing uncertain, variable or weak about the motive force in a Dunham Trap. When steam comes into contact with the thermostatic disc, it closes positively with a pressure of 14 pounds against the steam.

Full details of all Dunham Specialties will be found in the 15th edition of Sweet's Index, pages 1404 to 1409.

C. A. DUNHAM CO.

Los Angeles San Francisco Seattle
 600 Metropolitan Bldg. 524 Sheldon Bldg. 206 First Ave. So.
 Portland Spokane
 410 Board of Trade Bldg. 405 Sherwood Bldg.
 Administrative Office: Chicago, Ill.



TAY PIPE
 Valves & Fittings
 STEAM & WATER SUPPLIES
 Heating Material
 PLUMBING GOODS
 Pumps

GEORGE H. TAY COMPANY
 SAN FRANCISCO OAKLAND
 MISSION & SECOND STS. TENTH & HARRISON STS.
 TELEPHONE DOUGLAS 2240 TELEPHONE LAKESIDE 4200



The Master Lighting Fixtures

PERFECLITE Lighting Fixtures are totally unlike any other Fixtures. They flood the room with a soft yet brilliant light, so nearly resembling sun light that even the most delicate colors can be detected.

This is accomplished by an ingenious arrangement of mirrors which shower a wide area with a brilliant white light, softened and subdued by a scientifically devised thin blown Perfeclite Bowl.

For all commercial work, public buildings, stores, offices, hospitals, theaters, schools, etc. Perfeclites are unequalled for efficiency, beauty of design, and price.

Show rooms demonstrating the quality and efficiency of Perfeclites are maintained at both San Francisco and Los Angeles.

Our illuminating specialists are
at your **SERVICE** at all times

MYERS & SCHWARTZ

75 New Montgomery St.
San Francisco, Calif.
Phone Sutter 6178

1119 So. Los Angeles St.
Los Angeles, Calif.
Phone 15466

Bungalow Building Blox

Hollow Building Tile
Hollow Partition Tile

California Brick Co.

604 Mission Street
San Francisco, Cal.

BRICK

Red Ruffled Face Brick
Paving Brick
Step and Walk
Brick

BRICK

Enamel Brick
Buff and Old Gold
Pressed Brick

Livermore Fire Brick Works

604 Mission Street
San Francisco, Cal.

Fire Brick and
Molded Fire Tile

Architectural Terra Cotta



FULLER & GOEPP

32 Page Street, San Francisco. Telephone Market 499
PRIVATE EXCHANGE CONNECTING ALL DEPARTMENTS

MANUFACTURERS OF

MIRRORS, ART AND LEADED GLASS

Dealers in **WHITE** Glass for Table Tops, Counter Tops, Sink
Backs & Etc. Complete Stock - Prompt Deliveries.

Passenger and Freight Elevators



"MADE IN SAN FRANCISCO"

Factory and Warehouse, 166-180 Seventh
Street, San Francisco. Phone Kearny 66

SPENCER ELEVATOR COMPANY



RA-DO ^{FUMELESS} GAS RADIATORS

ALL CAST IRON -- 3 Sizes (3, 5, and 7 Sections)

The Ideal "Year-Round" Heating System
For The Home—New or Old

Easiest and Cheapest to Install
Lowest Operating Cost

BAIRD - BAILHACHE COMPANY

MANUFACTURERS

478 Sutter St., San Francisco

'Phone Sutter 6858

OLD MISSION PORTLAND CEMENT COMPANY



Each shipment of "OLD MISSION" Portland Cement is guaranteed not only to equal but to surpass all requirements of the standard specifications for Portland Cement as adopted by the U. S. Government and by the American Society for Testing Materials. A Guarantee Certificate is mailed with the bill of lading of each car, giving number of car, date packed, and number of barrels, over the signature of the chief chemist.

8000 SACKS DAILY

SALES OFFICE:

MILLS BLDG., SAN FRANCISCO

PHONE SUTTER 3075

PLANT:

SAN JUAN, CAL.



Architects make no mistake specifying

"FYER-WALL"

ALL METAL DOORS AND SHUTTERS

Inspected and Labeled by Underwriters' Laboratories

A Fireproof Door for Factories, Warehouses, Power Plants, etc. Cheapest and best fire door on the market.

FIRE PROTECTION PRODUCTS COMPANY

FIRE DOORS KALAMEN GENERAL SHEET METAL WORK

3117-3119 Twentieth Street, San Francisco

Phone Mission 2607



Keep Down Insurance Premiums

SPECIFY

SAINO FIRE DOORS

Standard Automatic Sliding or Swinging Fire Doors. Tested and Labeled by the Underwriters' Laboratories.

STEEL SASH AND HOLLOW METAL UNDERWRITERS WINDOWS

U. S. METAL PRODUCTS CO.

326-338 Tenth Street, San Francisco

A Practical, Durable Window Fixture

easily operated,

Is a delight to the housewife. Equip the windows of your client's home, Mr. Architect, with



HAUSER

Reversible Window Fixtures

Manufactured and installed by

Business College, Oakland, C.W. McCall, Architect

HAUSER WINDOW COMPANY

57 Minna Street, San Francisco, Cal.

Telephone, Kearny 3706



What's in a name?

VAN DYKE—the name of America's dominating drawing pencil.

VAN DYKE—the pencil with the 16 leads.

VAN DYKE—The masterpiece of Eberhard Faber, the Oldest Pencil Factory in America.

VAN DYKE—the word synonymous with every quality desired in a drawing pencil.

Now ask for **VAN DYKE** by name, at your stationers.



Samples of "VAN DYKE" Pencils and eraser, also booklet entitled "Eberhard Faber Pencils, How They Are Made", upon request on your business stationery. Address us at Monadnock Bldg., San Francisco.

VAN DYKE DRAWING PENCIL

EBERHARD FABER

"The Oldest Pencil Factory in America"

NEW YORK

When writing to Advertisers please mention this magazine.

“LUXOR ENAMEL”

WHITE HIGH GLOSS MIRROR LIKE FINISH

THE FINEST ENAMEL MADE FOR INTERIOR WORK

HIGH IN QUALITY — MEDIUM IN PRICE

UHL BROS., Inc.

SEATTLE

LOS ANGELES

PORTLAND

SAN FRANCISCO

OAKLAND

LEADER WATER SYSTEM

No country home is complete without this modern water system. Running water under pressure whenever and wherever needed. Convenient, economical, sanitary.

Pacific Pump & Supply Company, Distributors

851-853 Folsom Street
SAN FRANCISCO, CALIF.

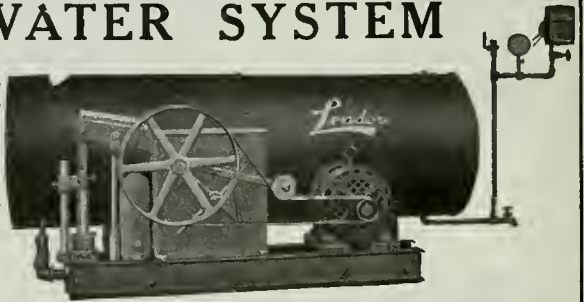

QUALITY HARDWARE



LOCKS AND BUILDERS' HARDWARE

PALACE HARDWARE CO.

"San Francisco's Leading Hardware Store"

581 MARKET STREET. SUTTER 6060



Pack your Radiator Valves with Palmetto Twist Packing

It can be unstranded to fit any size valve. It does not get hard.

H. N. COOK BELTING CO.

401-433 Howard St.

San Francisco, Cal.

**WESTERN
VENETIAN BLINDS
WESTERN**

ELMINATE the unsightly awnings — Preserve the exterior beauty of your buildings by *Specifying*

**WESTERN VENETIAN
BLINDS**

Some 1920 contracts for complete equipment:

- 12-story Mattie Building,
Fresno, California
- 9-story Pantages Building,
Los Angeles, California
- 7-story Marland Refining Bldg.
Ponca City, Oklahoma
- 10-story Tradesmens Bank Bldg.
Oklahoma City, Okla..
- 5-story Railway Exchange,
Muskogee, Oklahoma



LOS ANGELES TRUST
AND SAVINGS BLDG.
LOS ANGELES, CAL.



HAAS BLDG.
LOS ANGELES, CAL.



CITIZENS SAVINGS
BLDG.
PASADENA, CAL.



GLOBE GRAIN &
MILLING CO.
LOS ANGELES, CAL.



COUNTY COURT
HOUSE
WALLA WALLA, WASH.

When you consider the fact that **WESTERN VENETIAN BLINDS** take the place of both awning and window shade and will last practically as long as the building stands you'll realize that they are the logical equipment for modern buildings

WESTERN BLIND & SCREEN CO.
2704 LONG BEACH AVE.
LOS ANGELES CALIFORNIA

United States Steel Products Co.

Rialto Bldg., San Francisco

SELLERS of the products of the American Bridge Co., American Sheet and Tin Plate Co., American Steel and Wire Co., Carnegie Steel Co., Illinois Steel Co., National Tube Co., Lorain Steel Co., Shelby Steel Tube Co., Tennessee Coal, Iron and Railroad Co., Trenton Iron Co.

MANUFACTURERS OF

Structural Steel for Every Purpose—Bridges, Railway and Highway—"Triangle Mesh" Wire Concrete Reinforcement—Plain and Twisted Reinforcing Bars—Plates, Shapes and Sheets of Every Description—Rails, Splice Bars, Bolts, Nuts, etc.—Wrought Pipe, Trolley Poles—Frogs, Switches and Crossings for Steam Railway and Street Railway—"Shelby" Seamless Boiler Tubes and Mechanical Tubing—"Americore" and "Globe" Rubber Covered Wire and Cables—"Reliance" Weatherproof Copper and Iron Line Wire—"American" Wire Rope, Rail Bonds, Springs, Woven Wire Fencing and Poultry Netting—Tramways, etc.

United States Steel Products Co.

OFFICES AND WAREHOUSES AT

San Francisco - Los Angeles - Portland - Seattle

Planning the Private Garage



Bowser Oil and Gasoline Storage Systems

Are a necessity always, to make the garage complete — safe — convenient — and a saving proposition.

Bowser Equipment is Fire-Proof, Theft-Proof, Dirt-Proof and Loss-Proof. Because it is built to meet Underwriters' inspections — with every convenience and oil saving device.

Write or phone us at once for complete information.

S. F. BOWSER & CO., Inc.

FORT WAYNE, IND.

San Francisco Office: 612 Howard St. Telephone Douglas 4323
Sales Offices in All Centers — Representatives Everywhere

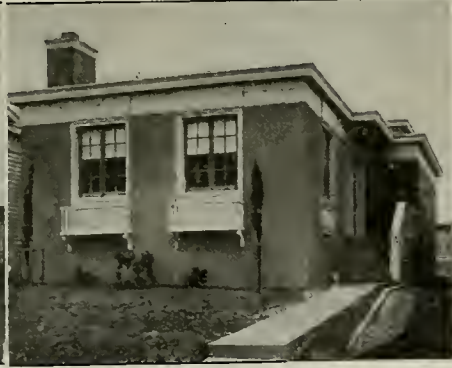
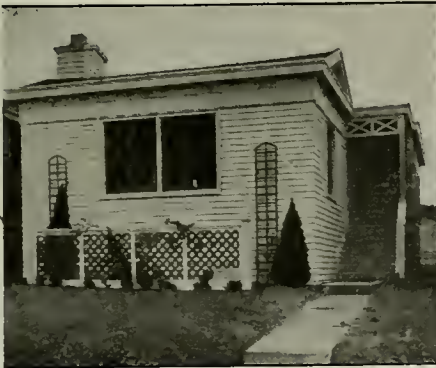

Cabot's Old Virginia White on Siding and Trim

Cabot's Old Virginia White on Trim

Morrow & Garren, Architects, San Francisco

CABOT'S OLD VIRGINIA WHITE—The Modern Architectural Outside White

The clean, brilliant "whitewash white" effect of Old Virginia White has real distinction. It is a softer and yet a brighter white than paint, and its texture and color-values are essentially different in character from the heavy, hard paint coating. This makes it especially appropriate for the modern "Colonial," because it gives the house at once the aspect of well-groomed old age—a result that it would take years to accomplish with paint.

CABOT'S OLD VIRGINIA TINTS

This softness and textural quality have led many of the leading architects to call for the same compound in tints, and Cabot's Old Virginia Tints are now made in a wide variety of delicate shades. The tones are almost pastel-like in quality, and the effects produced are most unique and pleasing. Send for Samples.

SAMUEL CABOT, Inc., Manufacturing Chemists, BOSTON, MASS.

Pacific Building Materials Co., San Francisco
Waterhouse-Wilcox Co., Los Angeles

S. W. R. Dally, Seattle
Timms, Cress & Co., Portland

Theo. F. Snyder, San Diego, Cal.

When writing to Advertisers please mention this magazine.



CENTRAL HIGH SCHOOL, MINNEAPOLIS, MINN.

Architect, William B. Ittner

Contractors, Pike & Cook Co.

Glazed by Forman, Ford & Co



The above Trade-Mark
appears on every light

**Completely equipped with American Window Glass Co.'s Double Strength AA Quality
First Choice of Leading Architects**

Because of its absolute dependability, American Window Glass has been used in many fine buildings. Our care in inspection practically eliminates all imperfections and assures uniformity in thickness.

American Window Glass Co., General Office, Pittsburgh, Pa.

DOMESTIC SALES OFFICES

New York, 220 Fifth Avenue
Chicago, 1011 Peoples Gas Building
Boston, Mass., 43 Tremont Street
San Francisco, Cal., 341 Montgomery Street
St. Louis, Mo., 1303 Syndicate Trust Building
Memphis, Tenn., 440 North Main St.
New Orleans, La., 904 Hennen Bldg.
Atlanta, Ga., 1408 Candler Building

EXPORT SALES OFFICES

Havana, Cuba, Apartado No. 930
Buenos Aires, Argentina
Mexico City, Mex., Apartado Postal No. 237
Barranquilla, Colombia
Bogota, Colombia
Valparaiso, Chile
Lima, Peru
Toronto, Canada, 205 Continental Life Building

Highest Quality

Finest Workmanship

Remco Redwood Tanks

Underwriters — Standard — Specials

All dimensions and capacities

Towers Designed and Erected

For Prices, Data or Estimates Phone GARFIELD 1910

Redwood Manufacturers Company

SOLE MAKERS

Hobart Building, San Francisco

When writing to Advertisers please mention this magazine.

JOHNSON'S ROTARY CRUDE OIL BURNER

Can be installed in any BOILER or FURNACE

Gives Satisfactory Results. Simple to Operate—
Automatic—Safe. Let us tell you more about this
Oil Burner.



BURNER IN OPERATION

S. T. JOHNSON CO.

1337 Mission Street - San Francisco, Cal.
Ask for Bulletin No. 28 Phone Market 2759

Agencies: SEATTLE LOS ANGELES FRESNO SAN DIEGO SACRAMENTO
Member of the Oil Burners Manufacturers' Association of California.

Fess System Turbine Fuel Oil Burner

The latest word in the science of burning fuel
oil in an efficient and economical method

Ask for Bulletin No. 20

FESS SYSTEM CO., Inc.

1310 S. HILL ST.,
LOS ANGELES

218-220 Natoma Street, San Francisco

HOUSTON,
TEXAS

Member of the Oil Burners Manufacturers' Association of California.

OIL BURNER EQUIPMENTS

Low Pressure Air and Rotary Mechanical Atomizing Types

Refrigerating and Ice-Making Machines

Direct Expansion and Brine Circulating Systems

T. P. JARVIS MANUFACTURING CO.

CONTRACTING ENGINEERS AND MANUFACTURERS

275 Connecticut Street, San Francisco

Phone Market 3397

Member of the Oil Burners Manufacturers' Association of California.



SIMPLICITY OF CONSTRUCTION together with
SUCCESSFUL and ECONOMIC OPERATION of

SIMPLEX BURNERS

reported by their many users, is the best recommenda-
tion we can furnish to those desiring crude oil burners.

American Standard Oil Burner

TRADE MARK

Phone BERKELEY 6389

Company

FIFTH AND PARKER STREETS
BERKELEY, CALIFORNIA

Member of the Oil Burners Manufacturers' Association of California.



Pump Governors	Oil Pumping Sets
Oil Burner Governors	Little Giant Improved
Reducing Valves	Oil Burners
Safety Valves	Duplex Oil Pumps
Oil Valves	Rotary Oil Pumps
Blowoff Valves	Oil Heaters
Boiler Feed Water	Draft Gauges
Regulators	Boiler Feed Pumps

G. E. WITT CO., Inc.
ENGINEERS

Manufacturers and Distributors

862-864 HOWARD ST.

Phone Douglas 4404

SAN FRANCISCO, CAL.

Chas. C. Moore Bldg.

Meyer & Johnson, Architects

Geo. Wagner, Gen. Contr.



VITRIFYX STOPPED
THE DUST IN THIS BUILDING

PACIFIC MATERIALS CO.
525 MARKET STREET, SAN FRANCISCO

A. F. EDWARDS, President
J. M. FABBRIS, Vice-President

J. A. MACKENZIE
Secretary

CHAS. F. EISELE } Asst. Managers
J. RUBIOLLO }

**AMERICAN
MARBLE & MOSAIC CO.**

25-29 Columbia Square, San Francisco
Telephone Market 5070

Factory on Canal, South San Francisco Telephone South San Francisco 161



DETROIT STEEL PRODUCTS CO., Detroit

Direct Factory Branch, 68 Post Street, San Francisco

Phone Sutter 125



The Architect and Engineer

CONTENTS FOR FEBRUARY, 1921

NUESTRA SENORA DE GUADALUPE, SAN FRANCISCO . . .	Frontispiece
<i>Charcoal Drawing by Rowena Meeks Abdy</i>	
SOME DRAWINGS FOR ARCHITECTS	PAGE 47
<i>Irving F. Morrow</i>	
A REMODELED HOUSE	64
THE PRESERVATION OF A CALIFORNIA LANDMARK	75
<i>Samuel E. Gideon, Associate Professor of Architecture, University of Texas</i>	
SOME NOTES ON APARTMENTS AND APARTMENT HOTELS	81
<i>R. W. Watson</i>	
ANALYSIS OF AIR FROM BURNING BUILDINGS	82
<i>S. R. Katz, U. S. Bureau of Mines</i>	
THE LEGAL REGULATION OF STANDARDS OF ARCHITECTURAL PRACTICE	83
<i>Emery Stanford Hall</i>	
AN ARCHITECT'S STUDIO	89
DAMP WALLS—THE CAUSE AND THE REMEDY	92
PROPER CARE OF CEMENT AND BRICK	96
<i>Diry Wells</i>	
COLLAPSE OF TEMPORARY SIDEWALK AT MARKET AND TAYLOR STREETS, SAN FRANCISCO	99
<i>J. J. Rasedale, C. E.</i>	
EDITORIAL	102-105
ELECTRICAL DEPARTMENT	106-107
WITH THE ARCHITECTS	109-113
WITH THE ENGINEERS	114-117
THE CONTRACTOR	118

PUBLISHED MONTHLY BY

THE ARCHITECT AND ENGINEER, INC.
626 - 27 FOXCROFT BUILDING, SAN FRANCISCO

W. J. L. KIERULFF
President

FREDERICK W. JONES
Vice-President

L. B. PENHORWOOD
Secretary



NUESTRA SENORA DE GUADALUPE, SAN FRANCISCO
CHARCOAL DRAWING, BY ROWENA MEEKS ABDY

THE ARCHITECT AND ENGINEER

FEBRUARY
1921



Vol. LXIV
No. 2

Some Drawings for Architects

By IRVING F. MORROW

FOR at least a century now the divorce between artisan and artist has been a subject for speculation and lament. How, we ask, are we to arrive at significant architectural results when the people who execute our buildings have neither understanding of the ends in view nor concern in their achievement? We are faced with the two-fold anomaly of the designer ignorant of working conditions and the worker ignorant of design. This situation, encountered equally in architecture and in each of the industrial arts, is recognized as potent among the influences leading to the sterility of much of the artistic endeavor of modern times.

But the dissociation of art and industry is not the sole subject for regret. We are witnessing an attendant phenomenon in the dissociation of the various arts themselves. Time was when the field of art was one undivided domain. Then the architect carved and the sculptor painted and the painter designed buildings and all wrote poetry which was respectable, even when not distinguished. Today the arts are kept in thought-tight compartments. The artist "specializes"; which is to say, his culture is incomplete and one-sided. Not only has he ceased in any large degree to attempt creative work in arts other than the one particularly his; he has ceased to show understanding and appreciation outside the limits of his special field. The literary worker of distinguished talents may be quite insensible to the principles, aims, and appeal of the plastic arts; the painter gifted with the subtlest feeling for line and color is as likely as not to manifest a cabaret taste in music. And if there be any art on which the knowledge and opinion of other artists is usually negligible, it is architecture.

Painters maintain that architects' drawings do not interest them. In this it must be admitted that they are only too frequently justified; it is difficult to see why architects' drawings, taken at their average, should

interest anybody of artistic perceptions. But the painter himself, on the other hand, is in equally bad grace with the sensitive architect. The average painter or graphic artist will draw a face profile with exquisite sensitiveness and feeling for the expressive quality of line; yet the same draftsman, delineating a building, will obscure or falsify the very characteristics which make it worth while to an architect. It is sometimes pointed out in explanation that the architect's attention is occupied primarily with details, while that of the painter is fixed on the broad aspects of appearance. Such a reason will not square with the facts. Any architect who ever com-



ITALIAN FOUNTAIN AND SPANISH HOUSE, SAN JUAN, CALIFORNIA

Charcoal Drawing by Rowena Meeks Abdy

posed a good building knows that details must be subservient to composition; and every well-trained painter has applied eye and hand to small elements as well as large aspects. It would be more just, albeit less agreeable, to say that the average architect does not realize the aims and methods of painting and the graphic arts, and that the average painter fails equally to apprehend the fundamentals of architecture—both its structural and practical basis, as well as the elements of design at its disposal. The result is that architects can complacently exhibit well composed buildings in drawings which are themselves poorly composed and devoid of atmosphere and reality; while painters are capable of rendering architectural masses, lines, and details in a manner which caricatures reality. The painter who can accord to architecture its true character—who, in a word, can produce

valid portraits of buildings—wins immediate recognition from the designers of buildings.

The charcoal drawings of Rowena Meeks Abdy are of the kind which gladden the architect. A painter who obviously enjoys portraying architectural subjects is a kindred spirit. Of the drawings chosen for reproduction—and let it be noted in passing that selection from an abundant supply of material uniformly appealing was a perplexing obligation—of the drawings chosen for reproduction, a third are specifically architectural in subject, and another third embody architecture as an important factor of the composi-



MONTGOMERY STREET FROM TELEGRAPH HILL, SAN FRANCISCO
Charcoal Drawing by Rowena Meeks Abdy

tion. And in each of the frequent cases where Mrs. Abdy has dealt with buildings she has done so with a scrupulous respect for their architectural truth as well as for their spiritual value to the scenes of which they have become a part. Simplification and suggestion she has carried to a point where everything superfluous or irrelevant has been unquestioningly suppressed. Yet the architect will delight in the sureness with which she has conveyed not alone contours, masses, profiles, details, materials and textures, but the sense of structure and weight as well. It is in her structural feeling, perhaps, that Mrs. Abdy most closely approaches the architectural point of view. It is evident not only in buildings, but equally so in the growth and branching of the many trees which she draws with intimate

sympathy, and in the varied configuration of the ground. Nor will the architect overlook the pleasant decorative sense in the manipulation of lines, spaces and values. Mrs. Abdy has executed water colors and oils in which her decorative feeling is strongly reinforced by a sensitive appreciation and unconventional use of color. It is hoped that at a later date we may be able to present some of these compositions, as well as work executed specifically as architectural decorations. She has also furnished illustrations in charcoal and pen and ink for *On the Ohio*, a record of travel by her husband, Harry Bennett Abdy.



SLOPES OF RUSSIAN HILL, SAN FRANCISCO
Sepia Drawing by Rowena Mecks Abdy

One is always impelled, in publishing drawings of any distinction, to offer an accompanying word of warning and explanation. People are prone to regard photography and photo-engraving as infallible processes in which exactness is assured by the following of certain scientific procedures. Anyone with experience in the reproduction of artistic material, in black and white no less than in color, will realize how far this is from the truth. Certain kinds of subtlety can fairly be counted upon to elude the camera and the etching bath; while these supposed servants of objective truth now and again play erratic pranks which are as difficult to account for as to circum-

vent. Following the reproduction of these drawings has enforced with renewed insistence the fact that, under the conditions of necessity obtaining in current commercial photography, engraving and printing, the most adequate technical equipment and the very best will and intentions cannot always be relied upon to secure entirely satisfactory results. Several drawings selected for this collection were subsequently withdrawn because it became evident that subtle relations of values, which were their whole merit, were almost certain to be lost. Between an original drawing and a good commercial reproduction there exists a difference about the same in

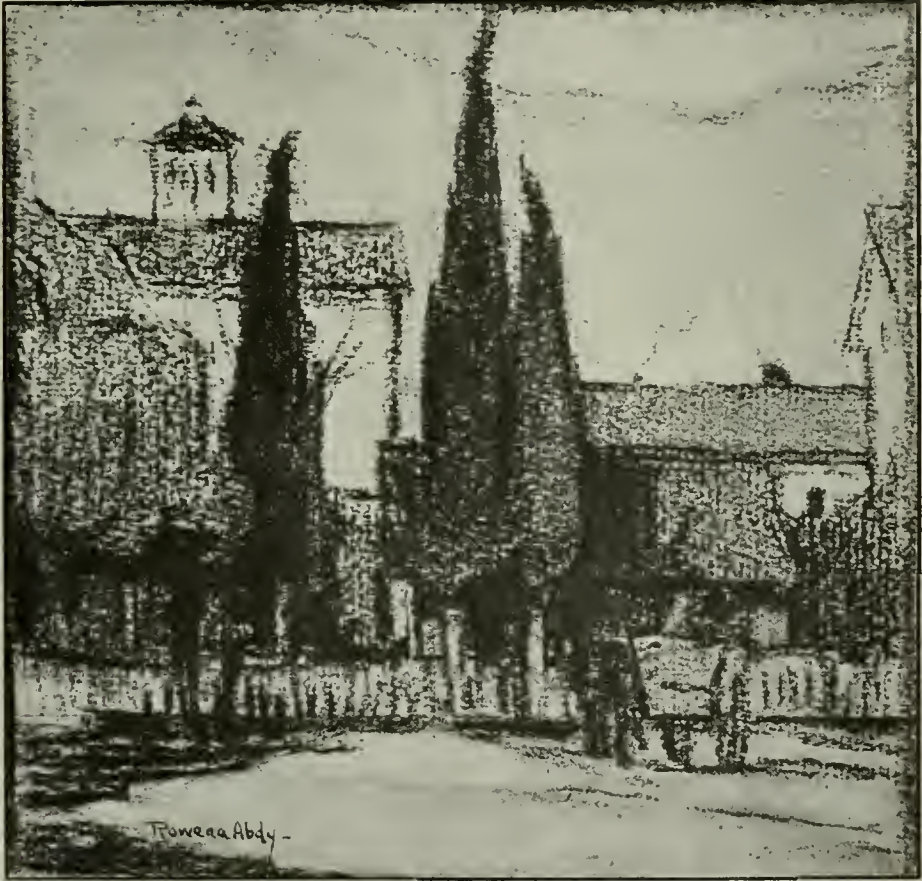

CYPRESSES, SAN JUAN, CALIFORNIA
Charcoal Drawing by Rowena Meeks Abdy

kind and degree as that obtaining between an original musical rendition and a good mechanical reproduction; or, to use a more homely comparison, between fresh and canned asparagus. One may use such records of creative work, and concede them genuine value; yet it is well to remember that the difference is real, and that, to whatever extent it may be minimized by scientific ingenuity, it will always be appreciable to the sensitive observer. In other words, it is a safe assumption that the original possessed virtues impaired in transmission; and the present instance is no exception to this dictum.



THE VILLAGE BROADWAY, SAN JUAN, CALIFORNIA
CHARCOAL DRAWING BY ROWENA MECKS ABDY

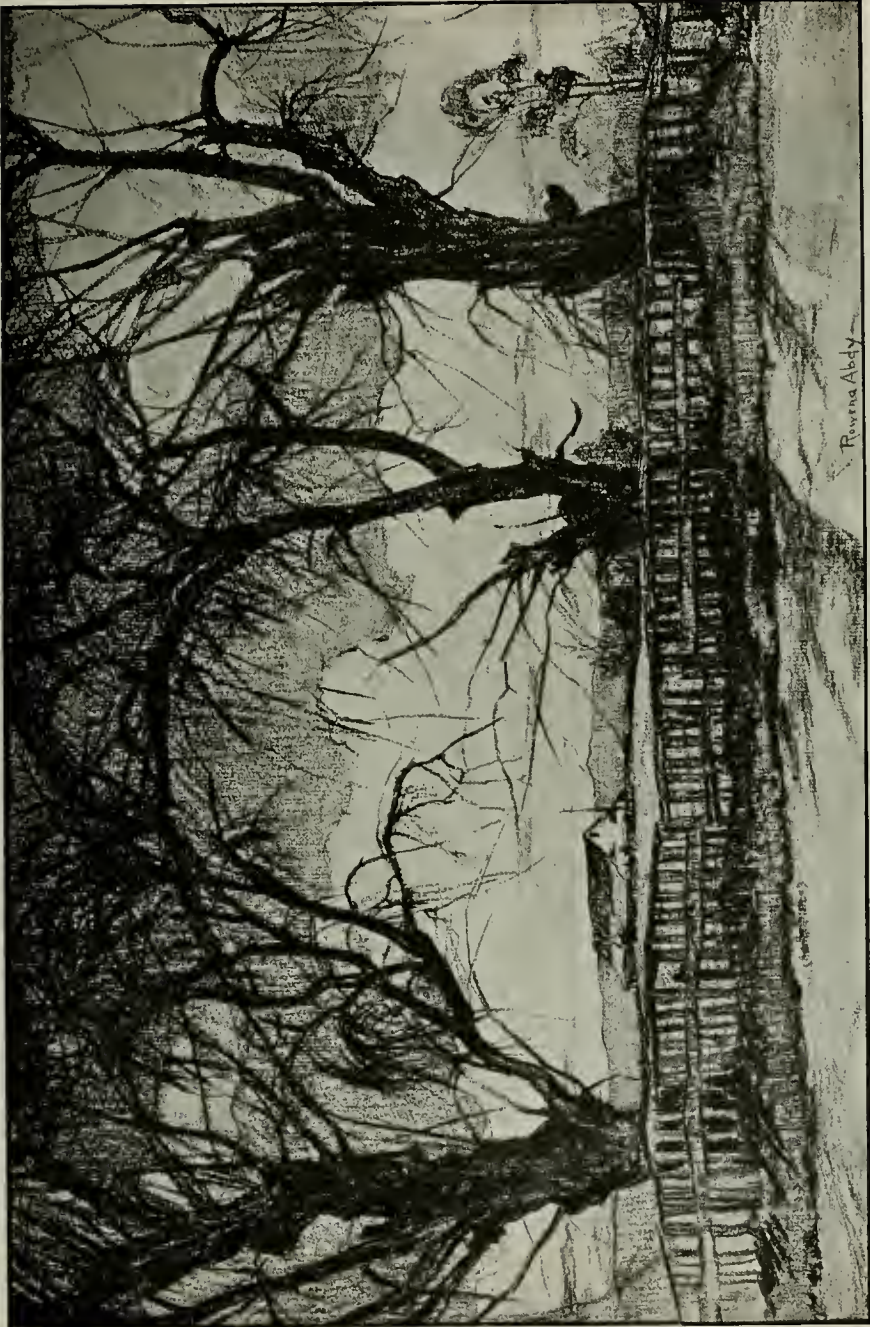

Rowena Abdy

ANCIENT WILLOWS, SAN JUAN, CALIFORNIA
CHARCOAL DRAWING BY ROWENA MEEKS ABDY



CASTRO HOUSE, SAN JUAN, CALIFORNIA
CHARCOAL DRAWING BY ROWENA MEEKS ABDY



VIEW AT SAN JUAN, CALIFORNIA
CHARCOAL DRAWING BY ROWENA MEERS ABBY

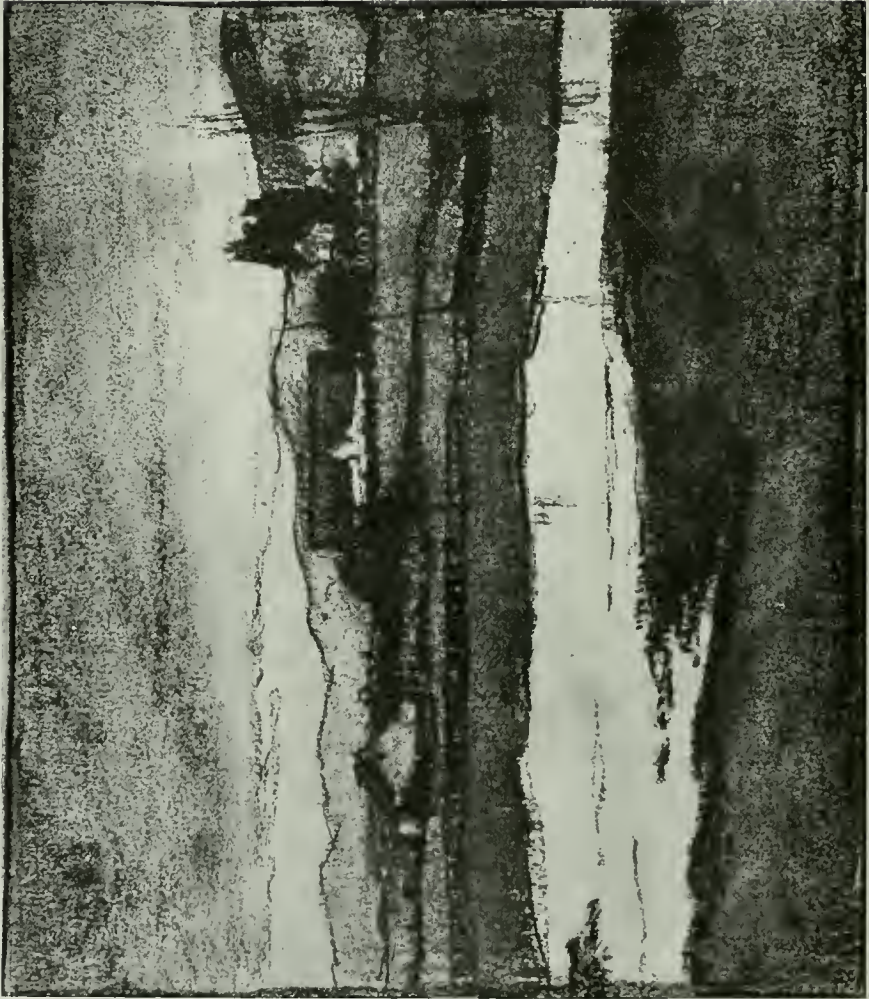

THE FLOODED MEADOW, SAN JUAN, CALIFORNIA
CHARCOAL DRAWING BY ROWENA MEEKS ABBY

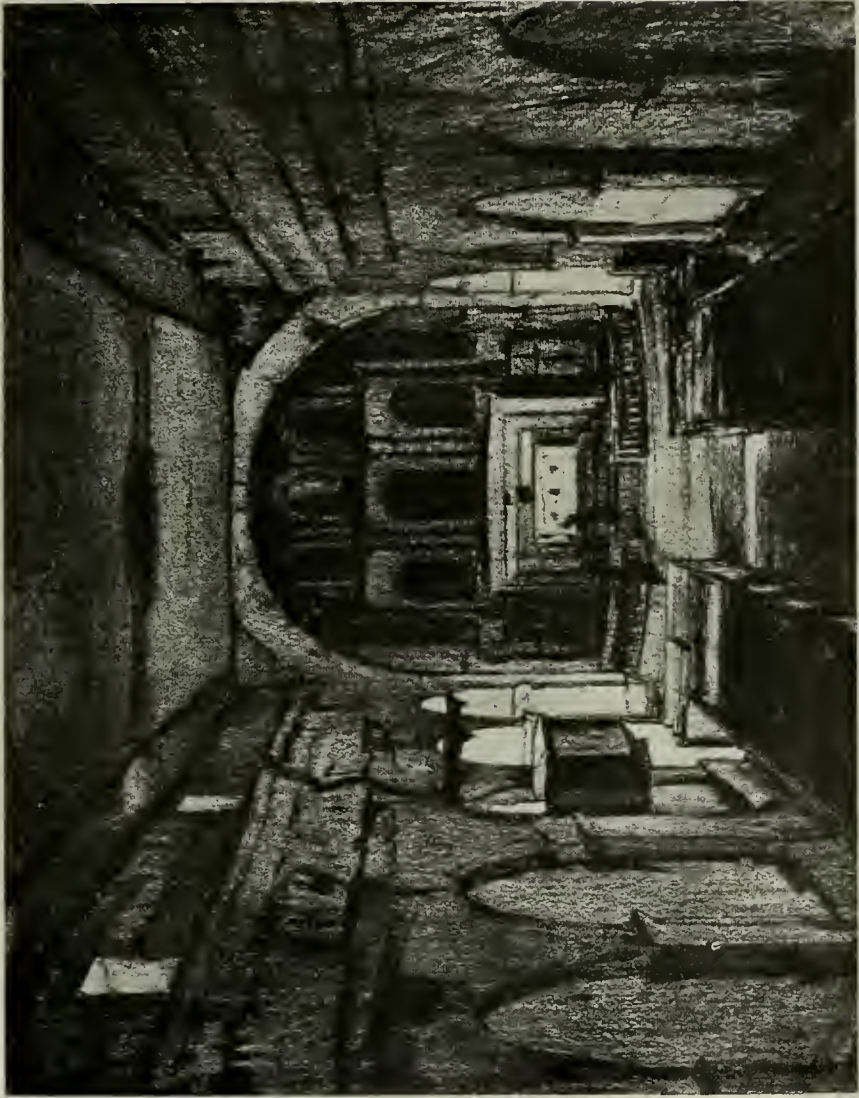

INTERIOR OF CHURCH, MISSION SAN JUAN BAUTISTA, CALIFORNIA
CHARCOAL DRAWING, BY ROWENA MEEKS ABBY



OLD MILL PORCH, SAN JUAN, CALIFORNIA
CHARCOAL DRAWING BY ROWENA MEEKS ABIDY



DOORWAYS AT MISSION SAN JUAN BAUTISTA, CALIFORNIA
CHARCOAL DRAWING BY ROWENA MEEKS ABDY

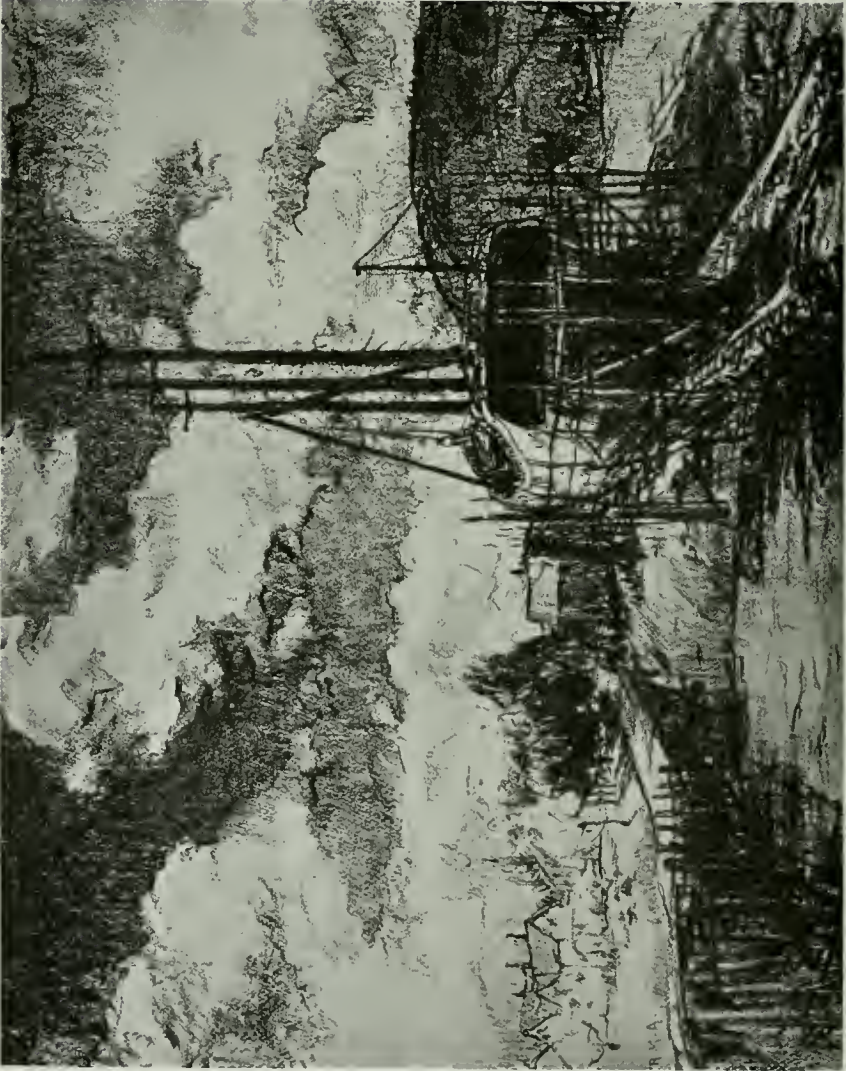

SHIPBUILDING AT CAMDEN, MAINE
CHARCOAL DRAWING BY ROWENA MEEKS ARDY



CAMDEN HARBOR ON PENOBSCOT BAY, MAINE
CHARCOAL DRAWING BY ROWENA MEEKS ABDY

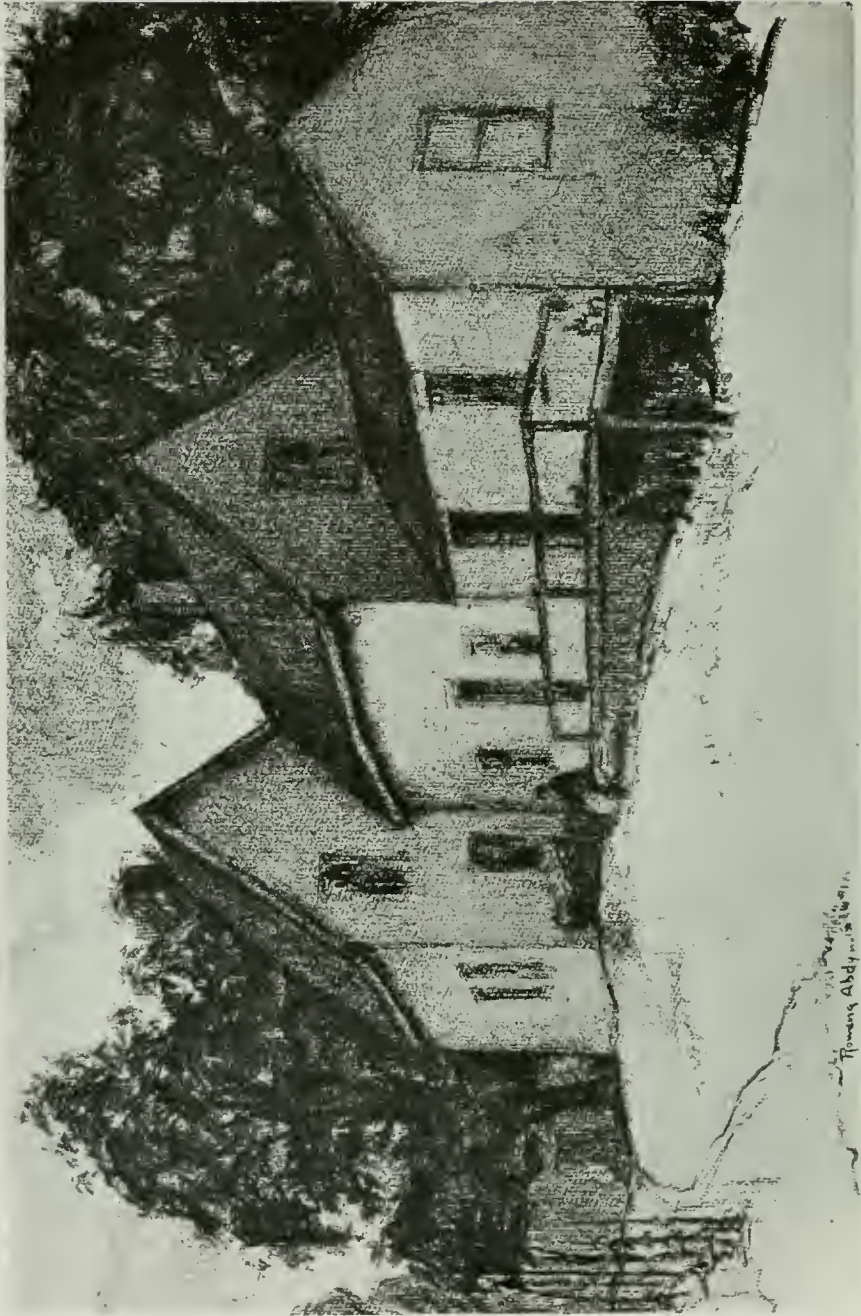

FISHERMEN'S COTTAGES, CAMDEN, MAINE
CHARCOAL DRAWING BY ROWENA MEEKS ABDY

Rowena Abdymeeke



ALBANY AND THE HUDSON, NEW YORK
CHARCOAL DRAWING BY ROWENA MEEKS ABDY

A Remodeled House

OF the various superstitions obstructing the free and logical development of architecture, one of the most pernicious is the conception of "front" and "back." We have not even yet freed ourselves from the incubus of this relic of the dark ages (nineteenth century). The idea seemed to be that the street was the thing. A house was built solely with reference to this frontage, irrespective of all other considerations which would reasonably govern, such as contours, outlook and exposure. The



VIEW BEFORE ALTERATION. HOUSE FOR MR. AND MRS.
H. B. ABDY, SAN FRANCISCO.

statement of such a proposition should be enough to establish its fallacy. Yet throughout its length and breadth the city of San Francisco is dotted with innumerable houses all identical in arrangement, without allowance for whether the lot be level or slopes to the front or the rear; or whether the view be to the front, side or rear; or for the bearing of the street or the side occupied. The loss has been incalculable, both to the appearance of the city as a whole and to the happiness of the individual inhabitants. San Franciscans who will buttonhole chance Easterners in Pullman smoking rooms and dilate on the beauties of their city and its bay, will ask no more at home than a "picture window" through which to observe houses as stupid as their own across the street.

The house which Mr. and Mrs. Abdy acquired to transform into a studio and residence was an excellent case in point. Standing on the north side of Lombard Street, just below the crest of the Hyde Street hill, it commands from the rear a blue panorama embracing the entire northern and north-eastern sweeps of San Francisco Bay. Yet the rear exposure had been made the "back" in the traditional sense of the word. It had been provided with few windows, and those high-silled; and of the first floor a good third had been wasted on a service and laundry porch.



REMODELED HOUSE FOR MR. AND MRS. H. B. ABDY, SAN FRANCISCO
Morrow & Garren, Architects for Alterations

The problem of alteration was three-fold. It comprised the liberation of this superb view, no less than the rearrangement of the plan to provide an artist's studio, and the replacement of decorative details in a manner consistent with sensitive tastes. The entire rear outlook is now utilized; on the first floor by a small vaulted dining room with broad, low-silled windows, and by Mrs. Abdy's studio, the end of which is glazed from wall to wall and from floor to ceiling; and on the second floor by Mr. Abdy's study and a bedroom. The rearranged plan also departs from convention in providing, not a stereotyped set of rooms, but just those rooms which comply with the owners' needs and manner of living. The main feature of the first floor is the studio, which is both atelier and exhibition room. The

living room in area is of minor importance. What is usually understood as a dining room has been replaced by a small so-called "breakfast room" for two, but the possibility of occasional larger dinners has been provided for by access between the pass-pantry and studio.

The nature of the architecture and decorative scheme was determined by the fact that the owners were in possession of an almost complete set of colonial and other old furniture for all rooms. This, however, served only as suggestion for the spirit of the scheme, any attempt at archaeology



HOUSE FOR MR. AND MRS. H. B. ABDY, SAN FRANCISCO
Morrow & Garren, Architects

having been deliberately avoided. The decoration throughout is neutral; warm gray only is used in the studio, while low colors are introduced elsewhere. This accommodates the display of drawings either in color or in black and white in any of the rooms. Fireplaces in both studio and living room have been designed with spaces for the insertion of mural decorations, which Mrs. Abdy is engaged in filling at the present time.

The exterior is painted a brilliant orange, with trim a little lighter and yellower, and shutters and sash of deep peacock blue. The effect is as yet a little raw and incomplete, due to the facts that weathering has not had time to take place, and that the gardens have not begun to make themselves felt.

I. F. M.

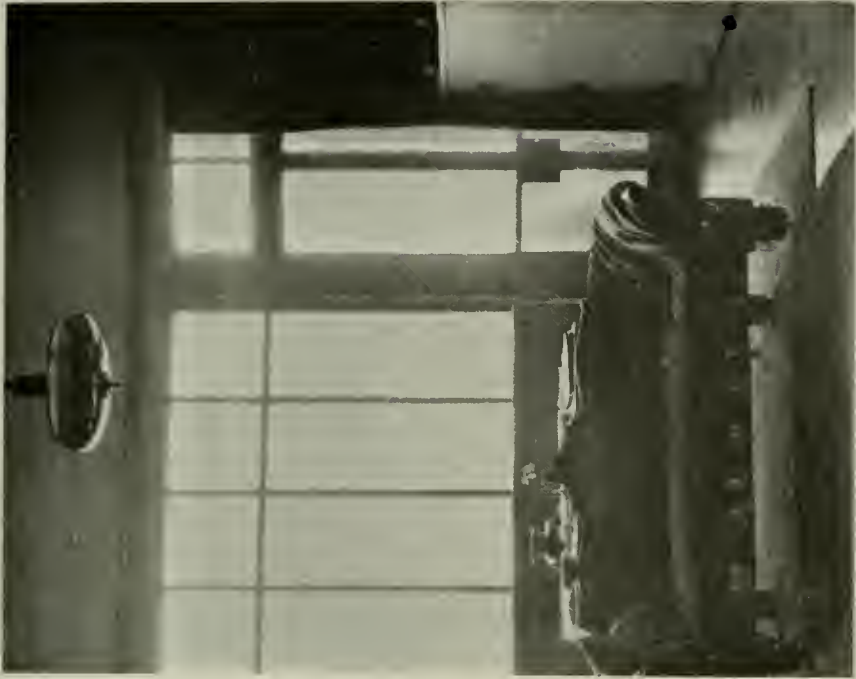

STUDIO
HOUSE FOR MR. AND MRS. H. B. ABBY, SAN FRANCISCO. MORROW & GARREN, ARCHITECTS.



DOORWAY

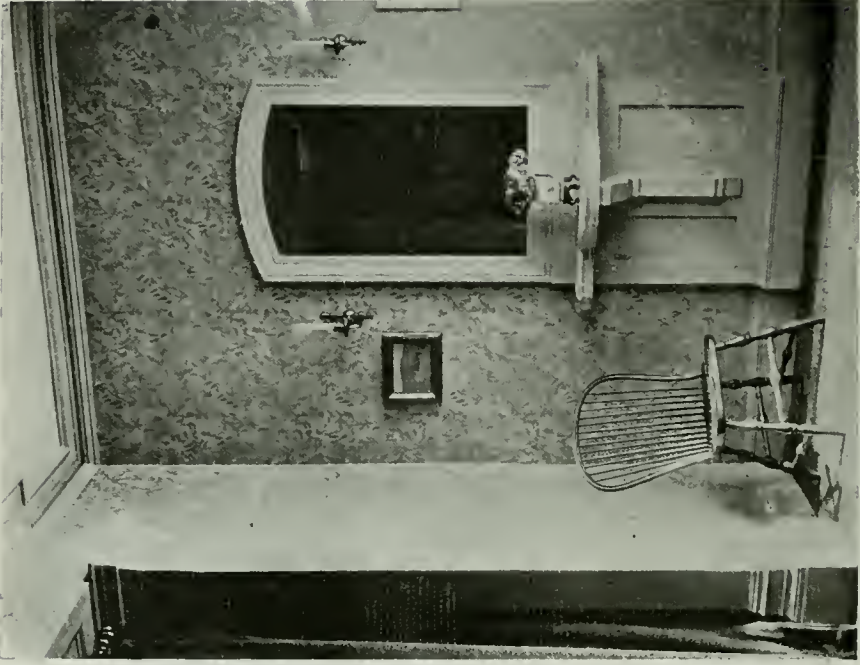

ENTRANCE HALL

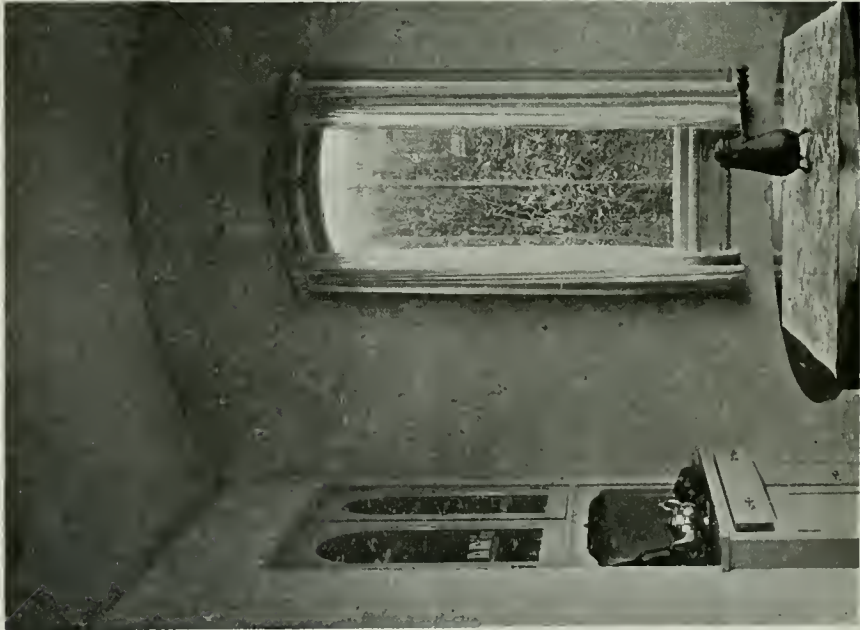

DINING ROOM

HOUSE FOR MR. AND MRS. H. B. ABDY, SAN FRANCISCO. MORROW & GARREN, ARCHITECTS.



STUDIO FIREPLACE
MORROW & GARREN, ARCHITECTS.



LIVING ROOM FIREPLACE
HOUSE FOR MR. AND MRS. H. B. ABY, SAN FRANCISCO.

A New Shop in Los Angeles

By RAY F. COYLE

WITH the intent of establishing a branch shop in the Ambassador Hotel, Los Angeles, Messrs. I. Magnin & Company of San Francisco leased space on both the lobby and casino floors of the hotel. For obvious reasons, the casino floor space was given over to the alteration shop, receiving department, employees' rest rooms, etc., together with a group of rooms for trying on and fitting garments. The space on the lobby floor was set aside for the display and sales rooms, stock rooms, offices and



STORE FOR I. MAGNIN & CO., LOS ANGELES

Ray Coyle, Designer

a smaller group of fitting rooms. A private stair connects the two floors so that the entire installation is self-contained.

Both designer and client, the latter represented by Mr. Grover Magnin, had the advantage of previous experience in making installations of similar character. Whatever success may have been achieved in the present undertaking is in no small measure due to Mr. Magnin's sympathetic co-operation and his appreciation of the fact that the initial expense adequate for well finished work is more than justified.

The area on the lobby floor comprised several bays at one end of the main lobby of the hotel. The problem presented was the utilization of this area in such a way as to obtain adequate sales space apparently free of columns. It was essential that this sales space should divide itself naturally into

three departments grouped around the entrance. In addition provision was necessary for display windows opening on the hotel lobby and for conveniently available storage space for a varied stock. Certain other conditions which are the result of considerations of demonstrated practical value bore upon the problem. It was thought very desirable, for instance, that the sales floor should be on two levels with a connecting stair as a decorative feature of the scheme.

The solution of the problem in planning is indicated clearly enough on the plan herewith reproduced. There is a central entrance lobby from which open two rooms of subequal size. These three are on the level of the hotel lobby. The main salesroom is raised two feet above this level.



STORE FOR I. MAGNIN & CO., LOS ANGELES

Ray Coyle, Designer

Direct access is had by a black and gold marble stairway opposite the entrance. This main salesroom is actually enclosed on only three sides, the fourth being pierced by very large arched openings. The intent was to avoid the danger of an appearance of disproportionate length. It was necessary to find some definite place for the display of dress forms in this room—and the none too novel expedient of niches was used. The windows of the hotel were masked by curtain walls and false windows, because raising the floor made the use of windows uniform with those throughout the hotel impossible.

Cases, both built in and movable, furnished space for the stock of small merchandise. The location of these cases was of necessity such as to provide for their most convenient access. Space for the stock of garments

which are suspended on iron pipe from hangers of the ordinary type was found at both ends of the main sales room. The stock space was divided with the intention of saving salespeople's steps between customer and stock.

In the consideration of the decorative treatment of the scheme the dominant purpose was to get a result which would convey a sense of delicacy. The shop was to be used for the display and sale of feminine requirements. The large body of buyers would be women. Further, the high grade of merchandise to be displayed demanded a setting which would have style—that quality impossible of definition. And last of all, while delicate and



STORE FOR I. MAGNIN & CO., LOS ANGELES

Ray Coyle, Designer

well bred, if possible it was desirable that the interior should be treated in a manner sufficiently novel to be in itself an attraction to visitors and thus an indirect advertisement.

The actual carrying out of the scheme with these qualities in mind was much simplified by the willingness of the owner to have every detail of the interior, from lighting fixtures to drawer pulls, carefully scrutinized from the standpoint of suitability. In the end the only stock articles utilized were certain small chairs. Every other item in the sales space was specially designed and made in San Francisco, including the wrought iron of the ornamental rail, the lighting fixtures, the bronze display cases and the furniture.

The color scheme was perforce based upon the color of a certain carpet which has been found to reflect an especially becoming light. The advantage of such usage in a shop devoted to selling merchandise whose value lies in its enhancement of feminine charm is self-evident. Fortunately we were able to find and purchase a year in advance sufficient yardage of a printed linen which married very nicely with the carpet. From this point on, the study of the color was merely a matter of carefully enlarging on this color group.



STORE FOR I. MAGNIN & CO., LOS ANGELES

Ray Coyle, Designer

The carpet is a gray red violet. This color then is the basis of the entire scheme. The walls throughout are canvassed, painted, stippled and glazed. The paint color is a neutralized green. The trim is a more solid green, glazed with a different color from that used on the walls. The cornice is a diluted green between the two, and the ceiling is a green gray which counts almost for white. The carpet color is carried up and accented in the window hangings, which are purple satin with linen insets in the valences and a green fringe trimming. Both dark natural walnut and green enameled furniture are used to give variety, and the accidental note is made by

the use of printed linen covering for the overstuffed pieces. The base in the lower rooms, together with the stairway are of black and gold marble, which tends to prevent the color from becoming sweet.

The rooms on the lower level are enriched by a polychromatic band of stenciling below the cornice. In the entrance lobby this is further enriched by the use of perpendicular bands in the corners. In this entrance lobby the ceiling, moreover, is varied from that elsewhere used in that it is of aluminum leaf very thinly glazed.

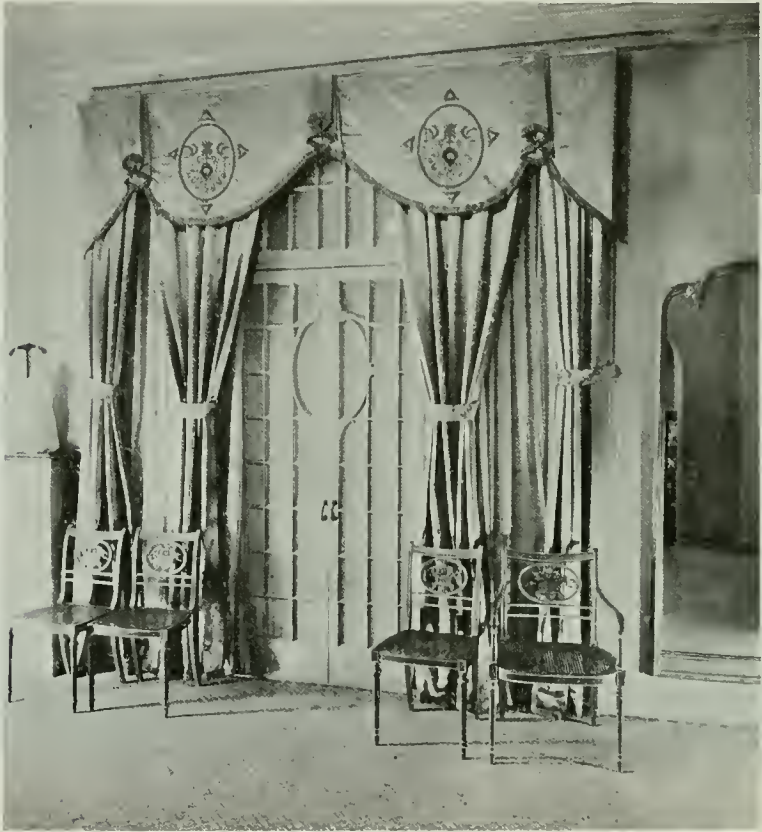

STORE FOR I. MAGNIN & CO., LOS ANGELES

Ray Coyle, Designer

There are six decorative paintings—two large lunettes overdoors, two small lunettes and two circular wall paintings. These are all painted over a prepared ground of gold leaf, on canvas. The canvas was then mounted in place in the usual way.

The exterior of the shop is entirely of walnut—simply two large display windows with an entrance through one of them. These display windows have no solid back, so that the interior of the shop is in plain view of a guest of the hotel standing in the lobby.

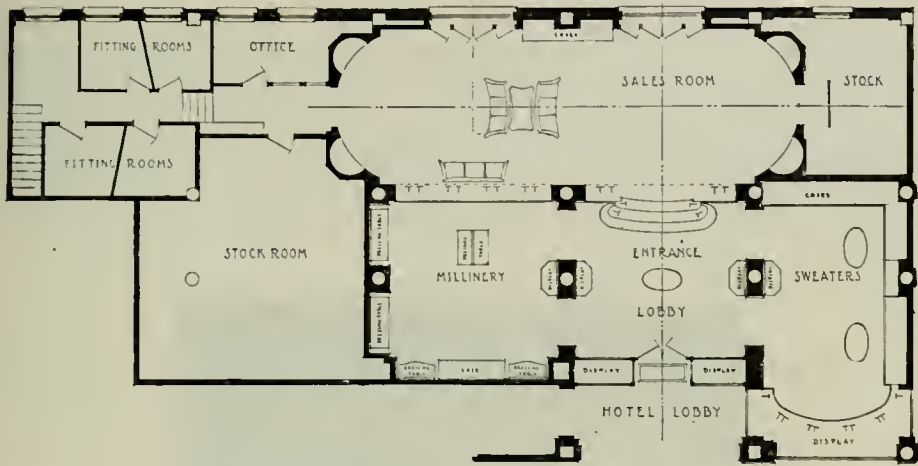

STORE FOR I. MAGNIN & CO., LOS ANGELES, CAL.

Ray Coyle, Designer

The Preservation of a California Landmark

By SAMUEL E. GIDEON,

Associate Professor of Architecture, University of Texas

MONTEREY, California, has much to boast of. Her history is unique; her setting quite picturesque; and she is mistress of one of the finest and most beautiful harbors in the world. The mere fact of Robert Louis Stevenson's living there and loving the town is enough to make it famous. To give some idea of the place before the advance of the "modernizer" or "restorer," I quote from a letter of Stevenson's to his friend, W. Henley:

"If you could only be suddenly dropped at the station, you would then comfortably enter Walter's wagon (the sun has just gone down, the moon beginning to throw shadows; you hear the surf rolling and smell the sea, the pines). That shall deposit you at Sanchez's saloon, where we take a drink. You are introduced to Bronson, the local editor. ('I have no brain music, you see,' he says. 'I'm a mechanic.' But he is a nice fellow.)

"Meanwhile I go to the P. O. for my mail; thence we walk up Alvarado street together, now floundering in the sand, now merrily stumping on the wooden sidewalks. I call at Hadsell's for my paper; at length, behold us installed in Simoneau's little whitewashed back room, round a dirty tablecloth, with Francois, the barber, perhaps an Italian fisherman, perhaps Augustin Dutra and Simoneau himself. Simoneau, Francois, and myself are the three sure cards, the others mere waifs.

"Then home to my great, airy rooms with five windows opening on a balcony; I sleep on the floor in my camp blankets; you install yourself abed. In the morning, coffee with the little doctor and his little wife. We hire a wagon and make a day of it."

Sixteen years later, Stevenson wrote of the place: "The town, when I was there, was a place of two or three streets, economically paved with sea sand and two or three lanes which were water courses in the rainy season, and were, at all times, rent up by fissures four or five feet deep.

There were no street lights. Short sections of wooden sidewalks only added to the dangers of the night, for they were often high above the level of the roadway, and no one could tell where they would be likely to begin or end. The houses were for the most part of adobe, many of them old for so new a century, some of very elegant proportions, with low, spacious, shapely rooms, and walls so thick that the heat of summer never dried them to the heart. At the approach of the rainy season, a death-like chill and a graveyard smell began to hang about the lower floors.



HOUSE WHERE ROBERT LOUIS STEVENSON LIVED
Monterey, Cal.

“There was no activity except in and around the saloons, where people sat almost all day long, playing cards. The smallest excursion was made on horseback. You would scarcely ever see the main street without two or three horses tied to posts, and making a fine figure with their Mexican housings. In Monterey you saw true vaquero riding, men always at the hand gallop up hill and down dale, and around the sharpest corner, urging their horses with cries and gesticulations and the cruel rotary spurs, checking them dead with a touch, or wheeling them right about face within a square yard.”

Present Monterey is a changed Monterey from that which Stevenson knew. Electric cars rumble noisily down narrow Alvarado street, paved sidewalks and streets have supplanted board walks and sandy roads. The automobile has banished horses, and the movies, candy, and soda shops have crowded out the old lounging places. There is an occasional saloon where "near" beer is sold. One place, longing for the old order of things, displays from its window a huge demijohn draped in black, bearing the placard, "Gone, but not forgotten," and another shows a flask in bed—the sign on



PRESENT CONDITION OF FIRST FRAME HOUSE IN CALIFORNIA
Monterey, Cal.

this one reading, "Not dead, but sleeping." Many of the old adobes still stand, some in spite of neglect, some hopelessly "restored," others oddly cramped in incongruous surroundings, and many still stand a credit to their present owners. Among the latter are the Sargent House, the Larkin House, and the handsome adobe now being restored and preserved by the Elkins family. Here it was found necessary to remove part of the old adobe wall at the rear of the house. The photograph, which is a rear view of the house, shows the adobe blocks carefully stacked. Let us hope that no rain will wash them away before they can be relaid. In order to make the lower rooms more comfortable, a drainage and heating system were



FIRST FRAME HOUSE IN CALIFORNIA, MONTEREY, CAL.
View Taken Some Years Ago.

installed by extensive excavations, but great care was taken to preserve intact the interior walls and woodwork. During all of the work of repair on the outer walls and the painting of the porch, the exquisite yellow rose vine kept on blooming as of old.

And now I come directly to the point I wish to make in this article. It is the plea for the preservation of the first timber house in California—a house under whose roof many early California romances occurred. Its distinctiveness lies not only in its being the first timber house in California, but in its simplicity of line. It is picturesque even in its ruins, and its traditions should make it dear to all Californians. I shall give a brief history of the house: In 1848 there came into Monterey harbor two Aus-



FIRST FRAME HOUSE IN CALIFORNIA, MONTEREY, CAL.
A Fairly Recent Picture.



HEADQUARTERS OF GENERAL SHERMAN AND OF CONSUL LARKIN (1834)
Monterey, Cal.

tralian ships loaded with lumber. The owner of the vessels, Mr. Botchson, seeking health for his invalid daughter, brought his family to Monterey. His practical wife, learning before they started on the trip that there were no houses in their wild prospective home, induced her husband to build a house in sections. This was done—each section being carefully fitted and numbered by skilled workmen in Australia so that they could be easily put together at their destination. It is said that within the phenomenal period of one week six small houses were ready for occupancy. Mr. Botchson had seen in his wife's practical idea a good business proposition. Four of the houses he sold, but kept two side by side for his own use. The three



OLD ADOBE HOUSE AND WALL, MONTEREY, CAL.

accompanying photographs of this most interesting California landmark show how rapidly it is approaching complete annihilation.

Where, California, is your Landmark's League? Your Legislature rescued Cotton Hall and the old Custom House, and individuals have saved a few of the missions. It is nothing short of a crime to witness the gradual dismemberment of such a worthy landmark as the old "Frame House." Shame, California, to let your giant redwoods shrink to shingles and boxes, and the missions crumble back to the dust from which they came. So your



OLD BALCONY, MONTEREY, CAL.

historic landmarks, such as the first frame house in California, will be only a memory, and your mighty highways will lead past signs reading, "Here Lies," "Here Stood," and other epitaphs to things that were.

I hail with joy the newly organized "Missions Preservation League." Its task is a stupendous one, but its enthusiasm is great. I hope that it will go out of its way a bit to reclaim this deserving neighbor to the beautiful old Royal Chapel in Monterey.

Perhaps Monterey herself can help.

* * *

The first skyscrapers on the west coast of South America are being erected in Santiago, Chile.

Some Notes on Apartments and Apartment Hotels

By R. W. WATSON, Spokane, in *Building Management*

IT SEEMS rather useless to say anything about the present situation as affecting apartments, since every owner or manufacturer of an apartment building is well acquainted with the existing situation.

What we would like to do is to look ahead into the next few years, that we may plan for the future of the buildings we now have, and look forward to the erection of the buildings that will be producing income as conditions warrant. It seems to me that the present situation is developing along somewhat new lines. I feel that there is demand for apartments from a class of people who never before sought to rent them, and that this tendency will increase rather than decrease, and that the apartment house will play a bigger part in the housing problems of the cities than it ever has before.

The modern apartment house, practically speaking, is a recent development, dating back only about fifteen years. We all know the evolution of the apartment building during that time. To begin with, it catered mostly to the people who came and went frequently and who really did not consider the apartment a home. They are closely related to the hotel dweller.

The situation has changed and the demand for apartments now largely originates from a more permanent class of people. The present scarcity of dwellings has brought into the apartment houses people who never considered living in them before, and many of them will never revert to life in rented houses again. This is true for a number of reasons:

Many people have no desire to invest capital in a home, and feel that a rented house offers no permanent dwelling place.

Moreover, living in apartments does away with a great deal of work which is irksome to many people. The care of the heating plant, the lawn, the shoveling of snow and ice, the care of the plumbing and decorating and all the other incidental tasks about a house occupies most of their time outside business hours. These tasks convert many people to permanent apartment dwellers.

As rents have increased, there has been some change in the class of tenants in apartment houses, but generally speaking, the rents have not advanced so fast as incomes, and it is noticeable that the buildings offering the best accommodations and showing evidence of the best care and service for the tenants are most in demand. There is no objection on the part of the tenant to paying reasonable rents in such buildings; from a first to a second-class building is an easy step—merely a matter of a little carelessness and neglect.

Care in the selection of tenants and in maintaining the service and appointment of a building will permit top rentals a long time after ordinary usage might have reduced a building to second class.

This fact, together with the nature of the buildings being erected in the East, indicates that the next step in apartment house building will be toward more luxury and service to tenants at prices considerably above those now asked and received. The development of apartments leads toward the so-called apartment hotel, and recent news items tell of an apartment of this nature in New York City renting for as high as \$30,000 per year. Others in Chicago rent for as high as \$15,000 per year.

At present we manage no buildings where children are accepted. We find more objection to them from other tenants than from the owners. Personally I believe that an apartment is the last place to raise children,

and I have little use for those who, by choice, take children into apartments to live. Of course, there are exceptions. The future will, no doubt, provide apartments adapted for children, not subject to the criticisms of present buildings.

One economy in apartment house management that we have succeeded in effecting is in decorating. While the required combination is somewhat difficult, we have succeeded in employing janitors who could both fire the boiler and do ordinary kalsomining. The rule then is to do all the decorating required between April 1st and October 1st, when the firing requires little attention. This keeps the janitor employed the year around and the decorating costs little but the actual materials used. I believe we save easily two-thirds the ordinary cost and that we keep the building in better shape.

* * *

Analysis of Air from Burning Buildings

By S. H. KATZ, Assistant Physical Chemist, U. S. Bureau of Mines

AT the annual meeting of the International Association of Fire Engineers at Kansas City, Mo., the Bureau of Mines offered to co-operate with municipal fire departments for the purpose of obtaining information regarding composition of the air in burning buildings.

The gas-mask laboratory of the Bureau's experiment station at Pittsburgh sent vacuum bottles for taking samples to fire chiefs in twenty-five cities, who had signified their intention to aid in this work. It was hoped to obtain one hundred or more samples, because statistics in quantity are necessary for drawing reliable conclusions concerning the likelihoods of encountering irrespirable gas in burning buildings. Thus far, eleven samples have been received by the laboratory.

Eight of the eleven samples contained no carbon monoxide; seven of the eight were taken above the ground level and one below ground. One sample taken above ground contained 0.03 per cent carbon monoxide, and this quantity is not dangerous to breathe for a limited time. Of the three samples taken below ground, one contained no carbon monoxide; the other two contained 0.10 and 0.35 per cent, respectively. This indicates that in a burning building, the hazard from carbon monoxide is much greater below the ground level. The cause undoubtedly lies in the poorer ventilation that is usually found in cellars or basements. Abundance of ventilation provides the necessary air for complete combustion, or if incomplete combustion does occur, the carbon monoxide generated by the fire is greatly diluted with fresh air and swept away by the current. It may be noted that the highest proportion of carbon monoxide was found in a cellar where a fire was burning among piled cases. The difficult access of air to the burning parts facilitated the formation and liberation of carbon monoxide. The smoke here was very light and no difficulty was experienced in breathing. Some of the air containing dense smoke showed little change from normal air by analysis. Thus the density of smoke or the irritation and difficulty it causes in breathing are no indication of the presence of poisonous gas. None of the samples shows important deficiencies in oxygen.

It is hoped that in time more air samples from burning buildings will be analyzed in order to extend the little information given here. Especial credit is due the men who, in the turmoil and anxiety that accompanies efforts to subdue fires, and with possible danger to themselves, have been able to take the samples.

Legal Regulation of Standards of Architectural Practice

By EMERY STANFORD HALL,

Secretary-Treasurer of National Council of Architectural Registration Boards

IT may be safely asserted that a majority of the members of the architectural profession stand today as a unit in favor of some form of professional regulation. At least a majority believe in the establishing of a minimum educational, experience, and character standard as a condition precedent to the use of the professional title of architect. But whether this standardization shall be promulgated and enforced under the police power of the state as a measure of protection of the life, health and safety of the public in the form of a license, or under the power of the state to establish educational measures of fitness in the form of a titular standard, there is much difference of opinion.

The fundamental theory of the license form of police regulation is that protection of the public welfare can best be secured by the state first assuring itself of the expert knowledge of a certain designated class of its citizens and then depending on that class to act for the public's good. This theory is founded on the idea that if a man knows what is the right action to take and knows the calamitous consequences of wrong action, he will ordinarily do the right thing, acting either from moral sense or on account of the fear of evil consequences of wrong doing. By way of illustration, if an ordinary citizen makes a mistake in construction which causes jeopardy to life or property and that jeopardy becomes an actuality, he can be held responsible under the civil law for damages; but, if a proven expert does the same thing, he, because of his proven knowledge, can be held on the criminal law for a deliberate act to cause injury to his fellow-men. He, the expert, is estopped from setting up a plea of ignorance as an excuse for dangerous practice. If his act should result in loss of life, the expert may be held for manslaughter or murder, according as the outcome is proved to have been either the result of careless or deliberate intent. On the basis of this theory the license form of legislation says to the ordinary citizen, "Thou shalt not do certain things of thyself without the assistance of certain approved experts." By so doing it makes experts in that particular branch, so far as that line of endeavor is concerned, quasi public officials and depends on them as such to guard the public's interests, even against what may seem to be their own private interests. License confers certain duties on a selected class in exchange for certain service to the public on the part of that class. On no other basis can license be justified in equity. To argue that license is justified in protecting a certain class of citizens in their vocational means of livelihood over other citizens is to argue without legal basis. Class legislation for class purposes is unconstitutional and, therefore, class legislation is only justifiable on the ground of corresponding public benefit. Our friends who argue for license to insure themselves jobs against the other fellow are arguing without the law. The license method of regulation is restricted in its application. It can only go just so far as the limitation of police power which includes only the protection of life, health and property. In architecture, this can only include that portion of architectural practice which has to do with structural safety, sanitation, and the conservation of property. (Unfortunately America has not progressed sufficiently far in its legal theories to believe that wounds against the aesthetic sense constitute real injuries to society.)

Titular registration is nothing more nor less than the establishment of an educational standard. It serves merely as a unit of attainment—a profes-

sional measuring stick, if you will—which may be exceeded in good measure, but must never be less than certain standards. Titular registration confers no special privilege on any class of individuals. It does not say to the public, "You must employ thus and such persons," but it does say to the public that if they elect to employ thus and such persons with the right to bear certain title, they will find these persons reasonably skilled in the fundamental principles of their special line of endeavor.

In the eyes of the law, a pound of butter must be a pound of real butter. It may be good, better or best butter, but it must be butter. There is nothing to prevent the public using any kind of butter substitute that they may see fit; but, since Congress passed the Pure Food law and thus stopped the sale of fraudulent butter, has anybody noticed the price of butter go down? Economic necessity may force some of the public to use butter substitutes, but nobody wants to use butter substitutes and a few do who do not have to, while formerly many did without knowledge.

At the St. Louis meeting, representatives of the various architectural registration boards, legislative committees of architectural societies in states having no registration laws, members of the Board of Directors of the American Institute of Architects, and guests, met and compared experiences in the enforcement of registration and license laws, and, in the matter of endeavor to secure legislation, seemed to be, from sentiments expressed from time to time, unanimous in favor of the titular form of architectural regulation in preference to the license form. Yet they took no definite action, due to the fact that they believed that any pronouncement on this subject should come officially from the American Institute of Architects.

In the matter of administration of registration laws, certain difficulties seemed to stand out pre-eminently. Among these, the question of reciprocal exchange of registration between states was foremost.

Regarding this situation, the following facts were brought to the front:

That, while it was recognized that there is a common denominator of interest between all learned professions and that professions must stand together as one solid and united body on the principle that the public is entitled to have and maintain a class of thoroughly trained experts, a class to whom it may turn on occasion and find competent and unprejudiced advice on any technical subject;

It is evident that the vitality of the professions can best be promoted by preserving the distinct identity of the different elements forming the body of professionalism;

It was observed that professional regulation seemed to prosper best when administered under the educational department of state administration; and

It was admitted that, as long as we live under our present national constitution and the doctrine of state rights in local affairs is held as organic law, there will always be differences in laws in different states regulating the practice of architecture as of all other professions.

It was observed that, as legislatures differ in personnel, so will there be different laws promulgated by them.

And it was also observed that the very nature of an architect's business leads to inter-state activities and emphasizes the importance of some form of reciprocal exchange between the states.

In view of these observations, it seemed evident that there should be some national agency that could use its good offices to secure uniform standards of registration requirements and facilitate reciprocal exchange of registration between states.

Facing the foregoing facts, the St. Louis meeting did the obvious thing—organized the National Council of Architectural Registration Boards, and stated its purpose to be as follows:

“Its object is to foster the enactment of uniform architectural laws, equality of standard in examinations of applicants for state registration or licensure, and the establishment and maintenance of reciprocal registration between states having registration laws.”

In working out the purpose of the National Council of Architectural Registration Boards it has been discovered that in a majority of the states the examining committees or boards have discretionary power with reference to the maximum scope of examinations and entrance requirements, but do not have discretionary power with reference to minimum requirements which are in many cases fixed by law. With these limiting restrictions in mind, it was quickly seen that it would be possible to prepare an examination outline which would meet the requirements of every state having registration laws, although such an examination would be in excess of the requirements of many, if not all, states. This furnished the Council with the idea that it might work out a Standard N. C. A. R. examination which could act as the common denominator for all examinations and afford a standard medium of exchange between states, and the promulgation of such an examination was made part of the object of the Council. Of necessity, it is purely an optional examination; no one is compelled to take it. But any one who elects to take the examination and passes with creditable marks has a right to surmise that his transfer or registration from state to state will be very prompt and with the minimum of inconvenience, for he will know that he has passed an examination before one examining committee which meets practically every requirement of every other examining committee in every other state and is in excess of the requirements in most of the states.

The mode of procedure will be as follows: The applicant wishing to take a Standard N. C. A. R. examination will apply to the National Council of Architectural Registration Boards for such an examination and this Council will furnish his own local state examining committee with questions which, in addition to the regular examination of his own state, will raise the requirements of his own state examination up to the combined requirements of all states. After being thus examined, if the applicant has received a passing grade, he will be given a regular certificate of registration in his own state with the added notation on such certificate, “Examined on such and such a date by Standard N. C. A. R. examination.”

Such an examination might be taken at the time of the regular state examination for entrance to practice, or might be taken at a later date.

The fee for such examination would be twenty-five dollars, payable to the National Council of Architectural Registration Boards, and would be used for defraying the expenses of preparing examinations and carrying on the work of the Council, and would entitle the applicant to at least one inter-state transfer application, with only a five-dollar fee for additional transfer applications.

On the other hand, an applicant registered in the usual way in his home state could have his transfer to any other state facilitated by filing required information with the National Council of Architectural Registration Boards and paying a fee of fifteen dollars for the first transfer and five dollars for each additional transfer. In these cases the National Council upon receipt of application would make a careful investigation of the applicant's record in practice, collate the information, certify to same, and forward it to the

state where he wished to be transferred. The examining committee in that state would then examine the report of the National Council, and, if this report indicated a record in practice which in the opinion of the examining committee was sufficient, taken together with his examination record in the state wherein the applicant was registered, to equal the registration requirements in the state to which he wished transfer, they would approve of this reciprocal transfer and registration would be issued in this state without personal appearance or further examination. Such record would be reproduced in five copies, so that one copy might be forwarded to each member of the examining committee, and action taken in the application promptly between regular class examinations and without the necessity of calling a meeting of the examining committee in any state, simply by use of the letter ballot.

The great economic advantage of this system, both to the applicant and to the state, must be evident, traveling expenses would be saved, delays avoided, and the time of valuable men conserved.

Time prevents further elucidation of the details of operation of the Council. But the office of the Council, which is at 3230 West Monroe street, Chicago, will ever be ready to give the correspondence of any individual, state, committee, or society most careful and prompt attention.

* * *

The Building Outlook

By WILLIS POLK

THE future of the building business looks rosy—general business depression must soon end and its end is in sight. It will be followed by a literal boom in building.

Industrial depression, invariably coupled with deflation, came, placed its blight, and is now about to tip the hatgirl and depart. We must speed the parting guest and prepare ourselves for the new era. The one outstanding aspect of the situation is the present shortage in housing—domestic, industrial and commercial—the building business must supply this deficiency and is, therefore, destined to become tremendously active. First it must regain public confidence by putting its house in order. Capital is like a turtle, it withdraws into its shell if menaced, but like the tortoise it can outdistance the proverbial hare when its course is clearly defined.

It is now squarely up to those engaged in the building business to interest capital in prospective investments by proving that all elements of excess cost of material and low efficiency of labor have been or will be eliminated.

Labor must realize this and do its part; but the real canker sore most needing treatment is the so-called Cost Plus System.

Under this method, the efficiency of labor declined, some think as much as 50 per cent, certainly it is a system that puts a premium on incompetence, demoralizes discipline and terrifies capital. Instead of being a sore needing treatment, indeed a capital operation may have to be performed, anyway cost-plus is an incubus upon the building business and its vogue is on the wane.

Prior to re-establishment of complete confidence, capital must be shown that exposures the country over of price fixing in certain cases, are not indicative of a widespread combination comprising the building business as a whole. We must return to methods upon which the laws of barter and sale were founded. We must get back to sound fundamentals, with both labor and capital doing team work.

How Low Will Wages Fall?

SINCE 1913 wages have risen on the average about 80 per cent in America. Wholesale commodity prices in November averaged 107 per cent above the 1913 level. During our Civil War wages rose slightly, averaging in 1865 only 10 per cent above the level of 1860, whereas wholesale commodity prices rose 90 per cent during the same period. But in 1867 average wages had risen 10 per cent above the level of 1865, whereas commodity prices had fallen 24 per cent. Although commodity prices continued to fall after 1867 at the rate of about 4 per cent a year, wages continued to rise at the rate of 5 per cent yearly. In the year 1872 wages had risen to a level of 156 compared with 100 in 1860, or 56 per cent rise, whereas wholesale commodity prices had fallen to a level of 122, or 22 per cent above the level of 1860. Then came the panic of 1873, the effect of which was very slight upon wholesale commodity prices but quite severe upon wages. By 1873 wages had fallen from the 156 level of 1872 to a level of 134, a drop of about 15 per cent. During the same period wholesale commodity prices dropped to a level of 114, a decrease of only 7 per cent during the four years of "hard times."

To anyone who is interested in the probable future of wage changes, the facts just given will be significant. It is being commonly said that because commodity prices are falling, wages must necessarily fall. Yet it is evident that no such thing happened during the seven years that followed the close of our Civil War. One reason for the great rise in wages immediately after the Civil War is to be found in the fact that wages had risen but slightly (10 per cent) during the war, whereas commodity prices had risen enormously (90 per cent). The revival of industry following the post-war depression, created a demand for labor that caused a rise in wages. Relative to the prices charged for commodities, workers were underpaid until 1870, when wages and commodity prices both stood at a level of 136, or 36 per cent above the level of 1860, which was also the per capita increase in money in circulation.

Since wages in this country are now at a level of 180, compared with a level of 100 in 1913, whereas commodity prices are at a level of about 200, it is evident that commodity prices must fall another 10 per cent before wages and commodity prices will again be on a parity. The per capita money in circulation is now about 70 per cent in excess of the amount in 1913, and is likely to decrease relatively little in the next few years. For reasons given at great length in our issue of April 7, commodity prices always increase fully as much as per capita money increases; hence, one may look for an average price level of about 170 as compared with 100 in 1913. This will mean a further recession of about 15 per cent from the present level, which will probably occur within the next three months. To descend to this "new plateau of prices," present average wages now would have to drop only 6 per cent. Bear in mind that the great panic of 1873 caused a wage drop of only 15 per cent, and that it took three years to effect that decrease.

In the textile and metal trades the rise in wages during our recent war greatly exceeded the average rise. Textile and steel workers secured increases that averaged about 120 per cent. They will now probably suffer a decrease of about 20 per cent to bring them back to the general level of wages. In fact, such decreases have already been accepted by some of the workers in those two trades.

The wages of railway employees are about 80 per cent above the pre-war level, and freight rates have been increased about 75 per cent. There is

little likelihood that either railway wages or freight rates will be lowered for many years.

Skilled labor wages in the construction field now average less than 80 per cent above the pre-war level, but common labor averages about 120 per cent above the pre-war level. It is probable that common labor will have to accept a reduction of 20 per cent, this spring, but that skilled labor will not be reduced more than 10 per cent, if it is reduced at all.

Summing up, it is probable that a "new plateau of prices," about 70 per cent above those of 1913, will soon be in effect, and that both wages and prices of materials will take this new level. Whether prices and wages recede further from this "plateau" will depend mainly upon whether our per capita money decreases and our average efficiency of production increases. Those two factors are likely to change but slowly. Their combined effect will probably not lower the price level more than 5 per cent yearly.—Engineering-Contracting.

* * *

Construction Work Far Behind

Building construction in the United States is estimated to be behind from eighteen to twenty-four months in volume. This is particularly true of houses, apartments and tenements—structures used for actual housing purposes. The following tabulation shows for each of the last ten years (1911-1920) the estimated total cost of building, average cost per square foot, and number of square feet built:

Year	Total Cost	Average Cost per sq. ft.	Square Feet Built
1920.....	\$2,466,162,000	\$6.37	387,434,700
1919.....	1,467,821,300	3.20	458,600,000
1918.....	492,163,900	2.65	185,700,000
1917.....	816,941,000	2.27	358,500,000
1916.....	1,137,160,900	1.82	624,800,000
1915.....	931,937,300	1.52	613,100,000
1914.....	891,845,500	1.55	575,400,000
1913.....	980,971,600	1.61	609,300,000
1912.....	1,027,515,200	1.63	630,400,000
1911.....	962,499,700	1.59	605,300,000

For the five-year period, 1911-1915, the annual average construction was in excess of 600,000,000 square feet. For the succeeding five-year period, 1916-1920, the annual average construction was but 400,000,000 square feet. Total construction for the last five years is one billion square feet less than for the five years of the pre-war period. In other words, building is just that much short of what should have been done in order to care for normal needs and without allowance being made for increased building requirements created by increased population.

To take up this slack and meet necessary construction requirements, two billion square feet should be built in 1921 and 1922.

* * *

Novel Prison Bar Designed

A NEW type of steel bars designed for prisons is of hollow metal, filled with water. These pipes are all connected with a central pump, and the water is kept under high pressure. Thus, the slightest break in any bar would cause a powerful jet of water to spurt out. To continue filing the bar would be almost impossible. Also the fact that there was a leakage somewhere would be registered on a dial on the central pump, and lead to speedy investigation.



ENTRANCE, LA CABANA AZUL

H. H. Whitley, Architect

An Architect's Studio

[Courtesy of California Southland]

TAKING the beauty of California's out-door color into our homes is a subtle and difficult thing. We want seclusion, rest and shade without a loss of that cheerful air so characteristic of our climate.

To the mind of the Eastern furniture maker this subtlety of color adapted to environment can never be compassed. The artist who conceives a California interior successfully must have been to the manor born—only a life time spent in a country of two seasons can fit a man or a woman for the task.

Autumn coloring we have all through our dry season in Southern California. Not with the burst of splendor that accompanies the Eastern frosts—but in quiet tones and dusky yellows. Spring brings us soft misty grays



OFFICE IN STUDIO
OF H. H. WHITLEY,
LOS ANGELES, CAL.



FIREPLACE IN EXHIBITION ROOM,
STUDIO
OF H. H. WHITLEY, LOS
ANGELES



COURT, STUDIO
OF
H. H. WHITLEY
LOS ANGELES

and brilliant greens; and, through it all, the year round, the bonny blue of the sea and sky dominates.

It is the understanding of these background uses of California's color that has made La Cabaña Azul, so vital a factor in the home-making of today. The exterior, with its blue plastered walls, its red tiled roof and gay Spanish awnings is a familiar delight for all who catch a glimpse of it on Western avenue, Los Angeles.

Under the gabled tiled roof there greets one on entering, a domed hall, octagon in shape, and opening directly or by an arched hallway into all of the studio departments and offices.

The ceiling is blue, like the deep blue of Tahoe, fathomless and serene, cool yet colorful.

Opposite the entrance is the little court open to the sky; its pink walls and blue casements, its pool of yellow and blue water lilies, and the greens of grass and shrubbery make it a place of pure joy for those who care when things are well done.

To right and left of the court are drafting rooms, and an office.

To right and left of the entrance are the two rooms pictured, Mr. Whitley's study and office, and the large living-room set as a part of the studio for exhibition purposes, but also typical of all that dignified art can give to the interpretation of a handsome home.

The walls are mahogany color panelling rubbed with gold dust. The colors are brilliant, yet livable, and the sparkle of California sunshine seems to be entering through some fairy crevice, leaving outdoor its glare and heat. This is a most comfortable interior, giving us the blue and gold, purple and orange, green of the sunset sky and violet of the mountains all subtly woven into our surroundings like a happy memory of sunny days gone by. Seldom does one see so much variety made harmonious in a room.

Damp Walls — The Cause and the Remedy

THE attempt to remedy dampness in walls by the application of any protective covering to the inside of the building is hardly likely to prove a success, unless steps have first been taken to discover and remove the cause of the dampness. The most difficult cases to deal with are probably those in which the damp rises up in the interior of the wall from below the lowest floor. Examples of this kind of dampness are sometimes seen in old houses with basements; in such cases it is very doubtful whether a damp-proof course exists at all, declares the Western Canada Contractor and Builder.

Where houses stand in exposed positions, dampness soaks through flank and other walls, but in such cases it will probably be found that the brickwork has been laid in ordinary lime mortar. If, however, Portland cement was the cementing material, it may be found that the bricks are very soft. If the mortar in the joints of a brick wall crumbles easily when scratched with the point of a knife, it is extremely probable that the dampness of the wall is caused by the driving rain soaking through the joints; in such a case, raking out the joints to a depth of at least $\frac{3}{4}$ -inches and pointing with Portland cement may be sufficient remedy, but if the bricks are soft, and therefore porous, the outer face of the wall should be rendered in Portland cement compo.

Damp walls are frequently caused, especially in houses with basement stories, by the moisture of the wet earth outside the wall soaking through the brickwork. The remedies in this case consist of dry areas, or rendering the wall roughly in Portland cement; or better still, with asphalt. Where the ordinary damp course in a basement-story house is at about the basement level, the vertical damp course should extend from the basement level well up above the ground line, where it can finish without square or splayed arris or edge, forming a base or pinth; this base should be put wherever earth rests against the brickwork.

To insert a damp course in the walls of an old house is a difficult and expensive matter. The best way would probably be to insert a sheet asphalt damp course; the brickwork must be cut away a little at a time and the asphalt inserted and the cavity quickly filled. By the exercise of a little ingenuity, however, the asphalt may be kept in on long strip. Dampness on the inside of a wall near a window and elbow, or at the sill level, is generally caused by wet working through between the oak sill and the stone sill. Portland cement or red-lead pressed into the crack, or sometimes even a coat of paint, will be temporary and perhaps a permanent remedy.

Many devices have been recommended and adopted for overcoming the unhealthy effects of damp walls. It is only reasonable to suppose, however, that unless the cause of the dampness is removed so that the substance of the wall be kept perfectly dry, the evil is merely abated and not destroyed. Any weak place, if not quickly attended to, is sure to cause trouble, to say nothing of the possible inception of dry rot in the rafters. Where, however, radical alterations are impossible, the protective devices referred to are all more or less beneficial. Among them may be mentioned laminated lead for putting under the wallpaper before papering, and liquid solutions, like shellac, enamel paints that are to be used instead of papering or calcimining, sundry calcimines, and a solution that deposits an imperishable mineral in the pores of the plaster, rendering its surface hard and impervious.

Eaves and gutters that become choked and overflow, defective shingles, and an unsuspected leak in a down pipe, are all responsible for damp walls,

and should not be overlooked when searching for the cause of dampness. Any slight trace of dampness in the plastering is often made worse when several wallpapers have been put one over the other; even if the damp does not come through all the papers, the room has often a musty smell. In a case of this sort it is well, after stripping and preparing the walls, to let the plastering thoroughly dry before repapering is attempted.

* * *

The Architect's Right to Advertise

ASSUMING that the architect is capable, there seems no reason why he should not offer his services to any individual or corporation requiring his services, provided, of course, the field is believed to be clear and no effort is being made to take business from another. It must be remembered, however, that many an architect has hurt his reputation by approaching a man of conservative character, who is instantly antagonized by what he considers an unwarranted effort to forcibly establish business relationship, said Mr. A. H. Gregg, architect, in an address before the Ontario Association of Architects. Continuing, he said:

"In the same way the policy of an architect as regards advertising may be discussed. To my mind an architect has a perfect right to display his name on any building he may be erecting, or he may advertise in the daily papers or by circular or booklet, but the question still arises and must be settled by the individual, are such methods advantageous in the long run?"

"Group advertising, however, probably makes an appeal to the building public which cannot be obtained by individual advertising, and the campaign recently inaugurated by the association should have beneficial results for the members generally and should therefore have general support. Such advertising should educate the public as to the services rendered by architects, and thus enlarge their clientele, and it is probably one of the most effective ways of combating the encroachment by contractors, engineers and construction companies on the legitimate field of the architect. Such a propaganda should tend to stabilize the position of the architect and the service he renders, and with the hard-headed business man it may do much to root out the old idea of the architect as an artistic dilettante, utterly impossible as a man of affairs."—Improvement Bulletin.

* * *

Building — The Most Effective Form of Saving

With one exception, practically everything purchased with money goes to waste in a short time. So-called necessities, such as clothing, last only a few months, and then are worthless. Only a small amount of food consumed really goes into body building. Even machinery for factories has relatively few years of usefulness before it is replaced or becomes obsolete.

Building represents one form of expenditure with a minimum depreciation. Buildings average from twenty-five to fifty years in usefulness, and with the present permanent types of construction their life is practically unlimited. Every dollar put into building construction means an increase in national wealth. Put into almost anything else, it is soon dissipated into nothing.

Building, therefore, should have the moral and active support of every farseeing interest in the country. Government, banking and business should find means to encourage more building. Money so spent will mean a saner, happier and wealthier country redounding to the benefit of everyone individually and collectively.—Modern Building.

Co-operation Between Architects and Labor

THE various chapters of the A. I. A., and State associations of architects have been furnished with the following information regarding co-operation between architects and labor now being developed in Philadelphia, with the idea of encouraging similar co-operative efforts in other localities:

Mr. D. Knickerbacker Boyd, former Secretary of the Institute, conferred with the council of the Associated Building Trades for Philadelphia and vicinity (composed of all branches of the industry except carpenters), and requested opportunity to address that body on the subject of bettering conditions in the building industry, which request was granted. Mr. Boyd urged the need of closer co-operation between the various elements in the industry, that the mechanics might know better the aims of the architect, and that the architect might help to create in the mechanic a keener interest in his work and in the results sought for in the architect's designs, to the end that they might all help to develop themselves as instruments of service for the good of the industry.

He suggested that the Council provide opportunities for lectures on the crafts, plan reading, etc., and assured them of the co-operation of architects in such an undertaking.

The bricklayers promptly responded to the suggestion, and under Mr. Boyd's active leadership a meeting was held, at which a number of architects addressed the men, and offered their assistance and, as a first definite step in the program, a Plan Reading Class was started. This was conducted by Mr. Victor D. Abel, architect, every Thursday night, starting with an attendance of about 100 men, which gradually increased to the capacity of the hall.

Instruction was given in the reading of plans, the meanings of indications of materials on drawings, dimension lines, the placing of windows, partitions, the working out of stairways and the relation between the drawings and the specifications.

In addition to this class, Mr. Boyd arranged for speakers at as nearly as possible every regular weekly meeting of the Union, with subjects of interest to the journeymen who were present to the extent of three or four hundred at each meeting, these talks being followed frequently by interesting open discussion.

The following indication of the type of man and subject employed will perhaps be of assistance.

The President of the local Master Builders Exchange spoke of phases of building construction from the standpoint of the employer.

The Superintendent of Buildings of the Board of Education spoke as one familiar with the direction of building operations and related the industry to the educational system of the city.

An instructor in architecture gave a lantern slide talk on the best examples of brickwork in Europe and this country, and created in the men an enthusiasm and an increased appreciation of their craft.

The director of drawing in the public schools showed how important a part lessons in drawing and educating the eye and hand of children played in their later development as workers.

Various technically trained men spoke on the needs of sound types of construction, the strength of brick walls and piers and the effect of mortars in brickwork, the process of manufacturing brick, the characteristics and use of lime and cement, and similar subjects of direct interest to the bricklayers.

The results were as anticipated, the men gained through their contact with the architects a clearer knowledge of the architect's aims and a keener interest in their own work, and through contact with the various technically trained men connected with the industry, the men became more familiar with the materials with which they worked and the tools and traditions of their craft. In so far as this was accomplished the men became better mechanics and better citizens. Also the architects, through contact with the mechanics, gained a clearer knowledge of their point of view, that is bound to be of value in their professional work.

The men appreciated the difficulty of getting apprentices to enter the craft under present conditions in the face of the steadier and more protected employment in clerical or commercial pursuits, and they believed this condition could be improved greatly by stimulating a keener interest and joy in the work by means of co-operative measures, such as have been outlined above.

As a result of this first season's work an enlarged program is being prepared by the bricklayers for the coming season, which is to include classes for apprentices. Other trades are making similar plans, and all have apparently been imbued with a spirit of enthusiasm through the interest of the architects in their work.

As a further result Mr. Boyd has been designated as the spokesman for all organized labor in the building industry for Philadelphia and vicinity, including also the carpenters, who have since participated in the movement. As chairman of a committee on education and information, Mr. Boyd is hoping to arrange for conferences between employees and employed, in addition to a preliminary meeting held with the committee on industrial relations of the Chamber of Commerce of Philadelphia.

* * *

Clinics on Architecture

“WITH a desire to take its part in the development of the city of Toronto, the Toronto chapter, Ontario Association of Architects, offers its services in the form of a free architectural clinic,” says a statement issued by a committee, made up of R. K. Shepard, C. B. Dolphin and F. C. Lee. It goes on to say:

“The citizen building his own home is many times under the handicap of not having proper architectural advice, and it is with the desire to help such that the members of the Toronto chapter offer their services at these proposed clinics. Anyone not in a position to employ an architect and building his own home is welcome to attend. The Toronto chapter offers free architectural advice towards helping in the improvement of the standard of small homes and in a spirit of public service. Many men are capable of making their own drawings and will only require advice and guidance towards improving the appearance of the home and its arrangement. The Toronto chapter is preparing to offer standard sets of working drawings, descriptive specifications and schedules of quantities for a small nominal sum.

“We have made a beginning with the returned soldier, using the club house of the G. W. V. A. in which to hold our clinic. We wish to extend this clinic to the other classes of the community and will make arrangements to hold clinics in different parts of the city, whenever we have enough applications for advice from either the returned soldier or the citizens at large.”

Proper Care of Cement and Brick

By DIXY WELLS in Building Management

THERE has been great advancement in the last few years in the water-proofing and preservation of cement, stucco, plaster, brick, etc. This development has kept pace with the great cement industry, and of late years paint manufacturers have developed a preserving and decorative coating which also waterproofs exterior and interior surfaces of cement, stucco, stone, brick, plaster, etc.

It prevents the dusting up of interior floors of basements, etc., damp proofs interior walls, and prevents the salt-laden moisture penetrating into cement surfaces.

It colors and waterproofs cement building blocks, also oilproofs garage and engine room floors, and further prevents the disintegration of brick and mortar joints.

There are a number of good grade cement coatings on the market, the best being made from a cement-like base which is thoroughly ground in a light, volatile liquid, the foundation of this being to secure penetration, to cause the cement coating to bind and fill the inmost pores of the surface covered and to provide it with proper protection. The liquid, after carrying the cement-like particles deeply into the surfaces, causes them to crystallize and then to dry and evaporate. The pigment binds with the surface and makes the material thus coated impervious to moisture.

These coatings generally come in liquid form, some of them requiring a 25 to 50 per cent reduction before applying. Some can be used directly as they come from the can. They are applied with an ordinary brush in the ordinary way and flow easily, drying without showing either brush marks or laps. The first coat will usually dry hard in about twelve hours; the second, however, requires about twenty-four to thoroughly dry and crystallize. We recommend that you never use more than two coats.

The best grades of cement and brick coating are different from an oil paint; the latter gives protection to a surface by forming a hard, waterproof, leather-like film which entirely obscures the surface which it thus protects. An oil paint applied to cement, stone, brick and kindred materials becomes rapidly destroyed by the effect of the alkaline matter contained in these building materials. You see, the alkali attacks the vegetable oils which bind the paint, thus causing the paint to accomplish little, either from a decorative or protective standpoint, but a good cement coating is quite different. It really does not form a film but hardens the surface instead, and it penetrates and fills the pores and little voids, thus making the building material capable of resisting the destructive elements and mechanical wear. It has no weak compounds susceptible to the destructive effects of alkali, weak solutions of acids or the ordinary wear.

While a good cement coating is visible to the eye it is only because its use makes the surface uniform in color, and therefore very attractive in appearance. It does not, however, lie on the surface, but rather is absorbed by it.

The natural rough finish of cement is considered artistic; therefore, any coating which will hide this will prove undesirable. The natural, lusterless effect of cement is in no way impaired by the application of a coating, but rather is enhanced.

The average coating for cement has no gloss, but dries in the flat. It is usually made in white and a number of popular shades, all of which are alkali proof and non-fading. The coating does not crack or chip, and as

explained, it does not lie on the surface, but really becomes a part of the block to which it is applied.

Always remember that an oil coating applied to concrete will quickly perish because of the destructive effects these materials have on the film.

Moisture is fatal to most building materials. A little experiment with two bricks is very convincing. Soak one unfinished brick in a pan of water and it will take up about a pint. On the other hand, if you coat a brick with a good cement coating and immerse it in water it will absorb nothing. Imagine what this means to a good building. Imagine the weight with which it is taxed after a rain, for instance, also sub-surface walls which will always be damp unless properly finished. It makes buildings permanently rainproof and prevents a prevailing dampness in same from forcing the outer coats and leaving the surface in a shabby or mottled condition.

It is always well to use these on decorative concrete balustrades, ornamental concrete work, and all interiors of buildings which are of cement, stairs, corridor floors, etc. Without a similar coating brick or mortar will disintegrate.

On stucco, moisture absorbed by the porous surface expands on freezing, causing small cracks to appear, and these little hair line openings absorb large quantities of moisture which in turn expand in freezing weather and cause the surface to flake, chip and peel. Also moisture absorbed by stucco will in time cause the lath to corrode or rot and cause the stucco to fall off in sections.

When moisture strikes brick, stone or concrete, which contains soluble mineral salts, on evaporating brings to the surface the unsightly, dirty yellow or white discolorations which one frequently sees. This can be stopped and the surface restored to an attractive color by the application of a good cement coating. While the number of coats required will depend largely upon the condition of the surface to be finished, one coat is generally sufficient, and we feel that never more than two should be given. The user can easily determine the number needed by applying a brush full to the surface and thus test the suction or porosity. Extremely porous surfaces, of course, will require two coats, but upon those surfaces in good condition one as a rule is all that is required.

If you have any cement tanks in your buildings a good coat of cement coating will resist water pressure. Damp basements and damp interior walls caused by seepage of moisture can absolutely be prevented by the application of two thin coats of cement coatings. You see the action of salt is destructive to cement and concrete, and this can be overcome by the use of a good cement paint.

As there are a number of good colors from which to choose, attractive decorating effects can be secured, and goods of this character are particularly adapted to interior wall surfaces and also on rough oil finished plaster. Care, however, should be exercised in finishing plaster because it is not as porous as concrete, and if the coating is not properly reduced it will lie on the surface.

Altogether, a good cement and brick coating is invaluable to the average building owner, and its use should not be overlooked where it can be properly employed.

* * *
—and a Kick!

“Don’t they allow us to raise children in this apartment house?” “No,” said the janitor. “Nor kittens nor puppies nor parrots?” “No. Nothing is permitted to be raised here except rent.”—Washington Star.

Figuring Brick Work Accurately

SOME masons do not take any outs for the stonework that comes within the body of the brick wall on the theory that the quantity of brick you figure in will pay for the cost of setting the stone. This is a crude way of handling stone setting because, in most cases, it does not allow a proper amount for setting the stone, and also because it makes the quantity of brick inaccurate, just as the practice of "doubling the corners" does, says a writer in *The Builders' Journal*. We know of some masons who, after leaving in the volume of the stone in their brick quantity, add an additional price for setting the stone, representing the "extra cost" of doing this over what they already have in as imaginary brickwork.

The procedure in getting at the quantities of brick would not differ essentially were use made of any of the methods noted, and the estimator who knows how to take off the cubic feet of brick can easily adjust his quantities to suit the contractor he may be working for. We shall proceed on the basis that the entire quantity of brickwork will be computed in one item and that the face brick will then either be deducted or priced as an "extra only" item. This really makes a difference only in the final figuring.

The man who prices "by the thousand" figures his brick in cubic feet and then multiplies by whatever number of brick he is in the habit of using. Below is given a table of comparative prices of brick "per cubic foot" and "per thousand." This table has been worked out to suit the contractor who figures anywhere from nineteen to twenty-four brick per cubic foot. We have occasionally met a contractor who figures even higher or lower than the range we have covered, but the majority of builders use a number covered in the table. It should be noted that it makes considerable difference as to how many brick are figured, as there is a range of about 25 per cent between the man who figures nineteen brick per foot and the one who figures twenty-four brick and sets the same price per thousand. From the prices given in the table it will be easy to work out intermediate prices or to extend the figures to cover the prices beyond those we have included.

COMPARATIVE PRICES FOR COMMON BRICK PER THOUSAND AND PER CUBIC FOOT

Price per M equals at	19 Brick per cu. ft.	20 Brick per cu. ft.	21 Brick per cu. ft.	22 Brick per cu. ft.	23 Brick per cu. ft.	24 Brick per cu. ft.
\$40.....	\$0.76	\$0.80	\$0.84	\$0.88	\$0.92	\$0.96
45.....	.85½	.90	.94½	.99	1.03½	1.08
50.....	.95	1.00	1.05	1.10	1.15	1.20
55.....	1.04½	1.10	1.15½	1.21	1.26½	1.32
60.....	1.14	1.20	1.26	1.32	1.38	1.44
65.....	1.23½	1.30	1.36½	1.43	1.49½	1.56
70.....	1.33	1.40	1.47	1.54	1.61	1.68
75.....	1.42½	1.50	1.57½	1.65	1.72½	1.80
80.....	1.52	1.60	1.68	1.76	1.84	1.92

* * *

Concrete Foundations for Machinery

Another use for reinforced concrete is in connection with the foundations for electrical generators, says *Engineering World*. Hitherto metal castings, weighing several tons, have been employed for this purpose. In addition to the great saving in cost which would result from the substitution of concrete for steel, the delays experienced in procuring such parts from the manufacturers would be saved, as the foundations could be manufactured on the site.

Department of Safety

Conducted in the Interests of the Building
Public and with the Co-operation of the
California Industrial Accident Commission

Collapse of Temporary Sidewalk at Market and Taylor Streets, San Francisco*

By J. J. ROSEDALE, C. E.

ON January 1, 1921, an inspection and investigation was made to determine the cause of the collapse of a temporary sidewalk at Sixth and Market streets, San Francisco, which occurred when the street was filled with the New Year's Eve joy-makers, at 11:45 p. m., December 31, 1920. The temporary sidewalk consisted of a 2"x12" plank floor, supported by two (2) 2"x8" beams, which were carried by two (2) 6"x6" posts, one resting on the curb and the other on the excavation. The alternate posts on the building side of the walk were supported by bracing and a 3"x14" beam, bolted to the adjacent columns. (See attached sketch.)

In checking the design of this walk, the following assumptions were made:

1. That the total live load did not exceed 65 to 70 pounds per square foot, which, with an allowance of 50 per cent for impact, will give a total load of approximately 100 pounds per square foot.

2. The extreme fiber stress in this structure was 2000 pounds per square inch. This is permissible in a temporary structure since the San Francisco building ordinances require 1600 pounds per square inch in permanent structures. Therefore, a stress of 25 per cent more in a temporary structure is allowable.

It was found that under a 100 pound per square foot load, the two (2) inch planking would be stressed to less than 1200 pounds per square inch. The two (2) inch flooring was therefore amply safe.

The 2"x8" beams were found to be stressed to 2400 pounds per square inch. These beams were aided to some extent by 2"x4" boards placed between the 2"x8" beams. The transverse bending stress in the 2"x8" beams was less than 2400 pounds per square inch, or probably 5 to 10 per cent.

Although the above figures show an overstressed condition in the 2"x8" beams, the overstress is not so great that a failure would be expected from this cause. A collapse could only be expected if a defective timber had been used.

In examining the broken pieces, there were no indications of any unusual defective timber nor was there any sign of their having broken by bending.

At the north side of the walk, the 2"x8" beams were fastened to the 6"x6" posts by four (4) 20-penny nails. Under a load of 100 pounds per

*Advance Report, California Safety News for February, 1921.—A full report, with pictures, of the failure of the dome of the First Christian Church, Long Beach, will be published in the March Architect and Engineer.

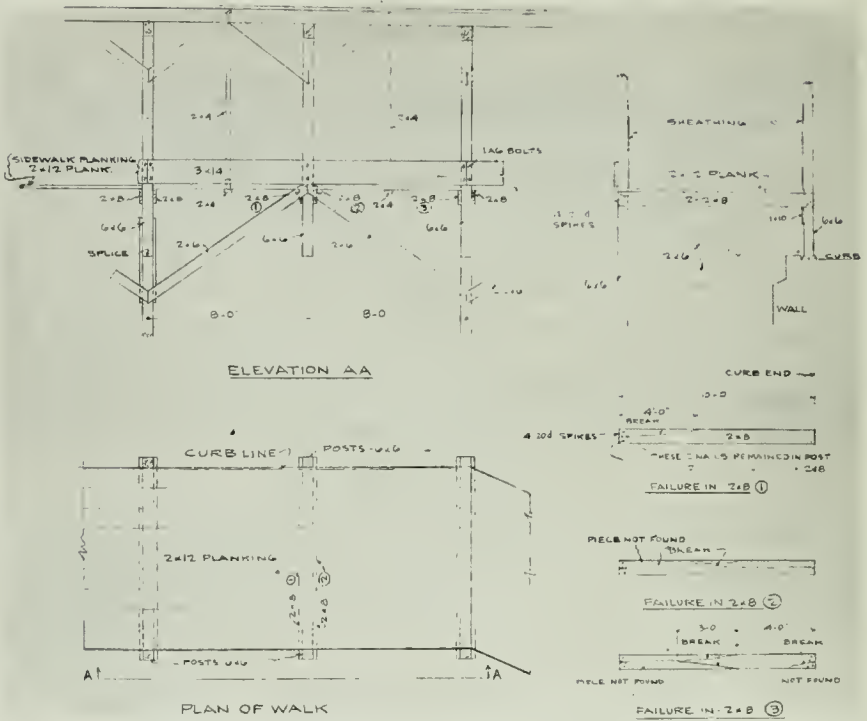

DETAILS OF CONSTRUCTION OF TEMPORARY SIDEWALK
Market and Taylor Streets, San Francisco

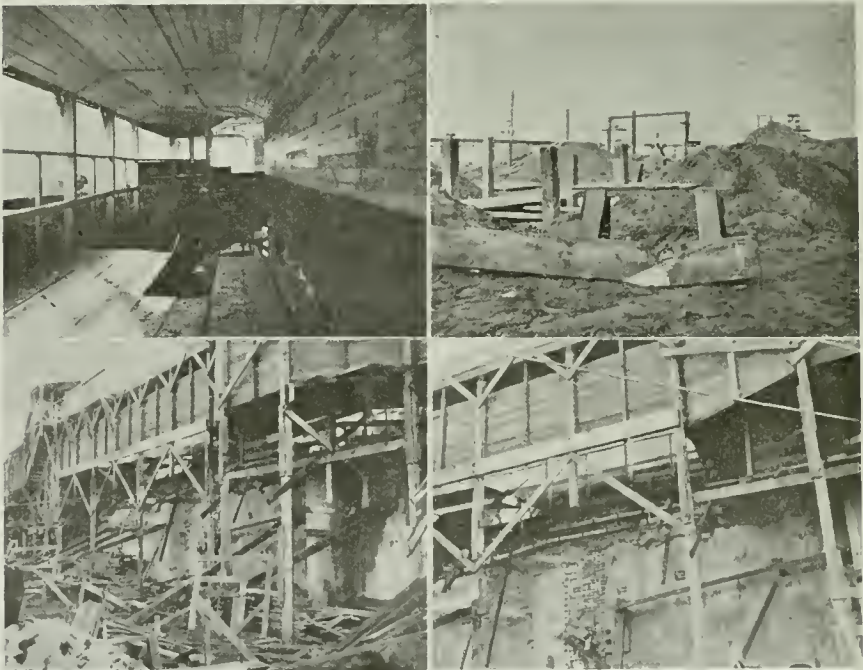

Upper Left—Collapsed portion of walk, looking west. Upper Right—Defective Plank. Lower Left—View of Sidewalk from Lot. Lower Right—Collapsed Portion of Walk.

square foot, each one of these nails would be carrying a load of 460 pounds, providing no allowance was made for a large friction force which exists at the contact surface between the 2"x8" beam and the 6"x6" post.

Engineers as a rule do not take into consideration friction forces in designing permanent structures, nevertheless, they exist and are a big factor in maintaining the stability of temporary structures.

Upon interviewing several eye witnesses, it was learned that there was excessive crowding and considerable stamping at the turn of the walk. This heavy load and constant stamping caused a considerable vibration which resulted in spreading the posts between the beams. It is probable that this condition destroyed the friction force existing between the 2"x8" beam and post, placing the entire load on the nails in direct bearing. Inasmuch as this would result in a stress of over 2000 pounds per square inch across the grain, the timber began to crush and bend the spike, causing the 2"x8" beam to split, which dropped the flooring to the ground. It is believed that the 2"x8" beam marked (1) in the attached sketch failed first. The other 2"x8" beams failed immediately afterward, causing the entire panel to fall.

An examination of the posts show that they are all in their original positions and there is no indication of any settlement.

While this structure was sufficiently strong for the daily public, which passed over it for the past four months, it was not safe for the large crowd which gathered on it during New Year's Eve.

This walk should have been kept closed on New Year's Eve, or any other time when large crowds will congregate on it, or else it should have been designed for at least a load of 125 pounds per square foot.

* * *

How Architects Can Prevent Wood Decay

THE chances of infection of timber by wood-destroying fungi while it is under the care of an architect or building contractor, and before it is placed in the structure, may be greatly reduced by following the hints issued by the Forest Products Laboratory, Madison.

The material should be stored on well-drained ground, where standing water or overflow water may not reach it. All rotting or infected debris should be collected and burned. Sound lumber should not be piled along with infected lumber. Weeds should be removed from about the piles to allow a good air circulation.

The foundation should be of material free from decay and should be high enough to allow good ventilation beneath the stacks. In humid regions the stack should be on foundations and eighteen to twenty-four inches from the ground. Wood treated with antiseptics, concrete, brick or other durable material should be chosen for foundation. The foundations should be built so that the piles will slope approximately one inch to every foot of length.

In most regions lumber should not be close-piled in the open, but should be "stuck" with crossers at least one inch thick. Lateral spacing is also very desirable. Roofing or cover boards should be used on the piles and should extend over for several inches in front and back.

Wherever infected or decayed material is observed either in the piles, or foundations, or the sheds, it should be removed immediately to prevent contamination of sound material. The material in close contact with the infected material should be carefully inspected to detect decay and, if infected, should be removed; if sound, an antiseptic solution should be applied. Water-soluble salts such as sodium fluoride, mercuric chloride, zinc chloride or copper sulphate are recommended.

**THE
Architect and Engineer**
INCORPORATED

Founded 1905 by E. M. C. WHITNEY

W. J. L. KIERULFF - *President and Manager*
 FRED'K W. JONES - *Vice-Pres. and Editor*
 L. B. PENHORWOOD - *Secretary*
 T. C. KIERULFF - *Attorney*

ASSOCIATE EDITORS

IRVING F. MORROW - *Architectural Critic*
 CHAS. H. CHENEY - } *City Planning and*
 } *Book Reviews*
 WILBUR DAVID COOK, *Landscape Architecture*
 WM. B. GESTER, - *Inspection and Tests*
 O. P. SHELLEY, C. E. } *Fireproof Construction*
 F. W. FITZPATRICK, }
 T. RONNEBERG, C. E., - *Structural Steel*
 W. H. LOWE - *Roofs and Roofing*
 FRED'K N. WOODS, JR., - *Rock and Gravel*
 W. H. GEORGE - *Cement*
 CHAS. FELIX BUTTE *Electrical Construction*
 H. J. BRUNNIER - *Reinforced Concrete*
 I. W. FRICKE, - *School Equipment*
 C. H. WHITE - *Hardwood*
 WILL J. FRENCH, *Department of Safety*

**Published Monthly in the Interest of the
Architects, Structural Engineers, Contractors
and the Allied Trades of the Pacific
Coast by The Architect and Engineer, Inc.**

PUBLICATION OFFICE:
 627-629 Foxcroft Building, San Francisco
 Telephone Douglas 1828

Portland office: 210 Stock Exchange
 Building, Portland, Oregon.

The publishers disclaim any responsibility for statements
 made in the advertisements of this magazine

TERMS OF SUBSCRIPTION
 (Including postage) to all parts of the United States \$2.50
 per annum; to Canada 75c additional; to all Foreign points
 \$1 additional.

Vol. LXIV. February, 1921 No. 2

BUILD NOW!

Prices have dropped from 10 to 60 per cent on nearly all the principal building materials. They are not going to fall very much more. Owners should build *now*. If construction is deferred another two months everybody will want to build at once. The inevitable result will be a return to higher prices.

Material houses should not wait for orders before shipping supplies from Eastern points to the West. Move materials now. Factories should not wait for orders before putting their plants on full time schedule. Start producing now.

The labor situation will take care of itself. Don't wait to see what the unions are going to do.

Bankers should loosen up and loan *now*. The housing shortage is acute—serious. Money is needed for 3,000,000 homes. It is estimated there are in the United States today 121 families for every 100 houses. Think of it! Let the banks and loan associations join hands with owners and builders and help to pull the country out of this disgraceful building rut. There is no good excuse for its existence.

Those identified with the building industry should, by all logical reasoning, to be enjoying two-fold prosperity today.

While others profited during the war, the building industry suffered because of government restrictions. Now it's the builder's inning. Confidence must be made a contagious disease, and it should be developed until it takes the form of an epidemic.

Build now.

**GROWING SCARCITY OF SKILLED
WORKMEN THREATENS BUILD-
ING INDUSTRY**

Senator William M. Calder, of New York, who, as Chairman of the Senate Special Committee on Reconstruction and Production, recently completed a nation-wide survey of the housing situation of the country, visiting most of the larger cities as far west as Denver, and receiving answers to questionnaires from every city and village in the United States, believes that one of the most important problems facing the nation today is that of obtaining sufficient skilled workmen in the building trades, and the Senator has written letters to the governor of every state in the union, urging that steps be

taken to establish trade schools in the several states for the purpose of encouraging young men to learn trades. Senator Calder believes that the building trades offer opportunity for young Americans unequaled in any other line of business in the country. The Senator's letter to Governor Stephens of California follows:

"My Dear Governor: A comprehensive study of the causes of the present shortage in housing and of the various factors entering into the building industry which have tended to retard its progress, has been conducted by this committee during the past eight months, and although we have not been able to visit every state in the union, we have covered all which the time at our disposal has permitted, and have interrogated authorities from all over the country in order to give a national scope to the study. Our investigation has enabled us, as a result of the perspective thus afforded, to ascertain some of the things which will remedy the conditions which are unsatisfactory and which hamper reconstruction.

"One of the outstanding factors which is now hampering the building industry is the curtailment at the source of supply of skilled tradesmen. The building industry is more highly organized than any other large industry, but it is noticeable everywhere that its members are now getting along in years, and in some trades the skilled young man is a rarity. It has been the experience of the past that the skilled mechanic in the building trades drops out very much earlier than in other trades and is forced to take up other or less skillful employment. His pay has accordingly been somewhat higher than the usual run, but the necessity for constant replacement has been ever present.

"The American youth takes kindly to the particular trades which require a little more skill than the others, and so we find among electricians, plumbers and masons numerous young men of American birth, but such is not the case with the other trades. Heretofore, men from foreign shores dis-

satisfied with the political and social conditions existing in their fatherland, have come to this country and, without serving a technical apprenticeship, they have started at the bottom of the ladder in the building trades. Those who have been worthy have risen to heights limited only by their ability. The country was a huge industrial training school where the building trades were taught largely to newcomers to our shores, but the ravages of war cut off this source of supply and the result is apparent on every hand."

The remedy seems plain—more apprentices.

This goes to the essence, for without apprentices we shall soon be short not only of journeymen, but of foremen and practical employers. The problem is: How shall this be achieved? The best solution seems to be through the fostering of building trades schools. Some of the states have, under their labor codes, authorized a State Industrial Commission to operate an Apprentice Department.

Notes and Comments

The Pessimists' Days Are Numbered

- Suspend all business!
- Quit buying and selling!
- Quit advertising!
- Quit eating!
- Let's give ourselves up heart and soul to an orgy of gloom!
- Let's howl and howl and howl!
- Let's cuss the country, business, our town, our neighbors and each other!

This is the way the Atlanta Constitution views the present situation, and adds:

"Let's get it all out of our system and then *Go To Work*.

Good advice, we'll say.

Industrial peace and industrial progress in San Francisco have been reasonably assured by a permanent arbitration agreement which has been signed by the San Francisco Building Trades Council, representing the workmen, and the

Industrial Peace for
San Francisco

San Francisco Builders' Exchange, representing the employers engaged in the building trades.

Under this agreement, which was brought about through the good offices of the Industrial Relations Committee of the San Francisco Chamber of Commerce, composed of Messrs. C. H. Bentley, J. B. Levison, Paul Shoup, Alfred I. Esberg, S. B. McNear and Miles Standish, the building contractors and the workmen have voluntarily set up a permanent Board of Arbitration and have bound themselves to submit to this Board of Arbitration for final decision all questions involving wages, hours and working conditions.

The members of the Board of Arbitration are the Most Reverend Edward J. Hanna, Archbishop of San Francisco; Max C. Sloss, former Justice of the Supreme Court of California, and George L. Bell, consultant in industrial relations and management.

All present and all future disputes in the building trades in San Francisco will be submitted to this Arbitration Board for adjudication, and its findings and judgment will be accepted as final by the parties to the agreement.

The hearings held by the board will be public, except as the board may decide otherwise, and the expenses incurred by the board in its work are to be borne equally by the parties to the agreement.

The agreement in full is as follows:

"1. In the matter of arbitration between the Builders' Exchange and the Building Trades Council, we hereby accept the following three arbitrators, to wit: Archbishop E. J. Hanna, Max C. Sloss, ex-Associate Justice of the Supreme Court of California, and George L. Bell, consultant in industrial relations and management.

"2. It is understood that all three arbitrators to be deemed impartial arbitrators of all controversies, and under no circumstances is any one of them to be considered a representative on the Board of Arbitration of either of the contending parties.

"3. It is agreed that this board shall sit as a continuing Board of Arbitration, to which shall be submitted all disputes as to hours, wages and working conditions in building trades where there are no disputes now, as well as in those where there are, when and as such disputes arise between

the signatory parties, and that the decisions of the board shall be accepted as final and carried out by all parties. This step is taken in order to provide a permanent method of settling amicably, and in a reasonable manner, labor disputes in this city affecting the building trades, and with the hope that building operations henceforth may be put on a certain and stable basis—a result which will be of advantage to the workers, to the employers, and to the public.

"4. It is agreed also that the Board of Arbitration may go into all questions concerning the general building situation, and call upon the signatory parties for information and copies of contracts or agreements concerning any phase which the board desires to investigate.

"5. It is further agreed that the Board of Arbitration may incur such expense as it deems necessary for the employment of investigators and clerical assistance; and that the entire incurred expense by the board will be shared equally by the signatory parties.

"6. It is understood that all hearings of the Board of Arbitration are to be conducted as public sessions, save, and except, such special hearings as in the judgment of the board should be held in executive session.

"7. It is understood that the trades in which there are now disputes concerning hours, wages and working conditions, which disputes will be immediately submitted to the board, are as follows: Painters, glassworkers, varnishers and polishers, cement finishers, cement laborers, hodcarriers, tending plasterers, marble rubbers and sawyers, marble finishers and polishers, marble masons, marble masons' helpers, hoisting and portable engineers, roofers, elevator constructors, elevator constructors' helpers, reinforced iron workers, team and auto truck drivers, plasterers."

Several weeks ago the San Francisco Chamber of Commerce initiated the movement which has resulted in this agreement by the employers and employees engaged in the building trades in San Francisco. The special committee on industrial relations was named by President Atholl McBean, and this committee was empowered to examine into the whole building trades situation and to bring about a more wholesome condition of affairs.

This committee conducted a searching inquiry into all the matters involved, and undertook the difficult task of bringing the employer and the workmen together for the purpose of ascertaining and adjusting the differences that have operated to keep them

apart, and to find a basis for a definite and permanent agreement for the peaceful settlement of all differences that might arise.

In discussing the result of the work of the Chamber's special committee, President McBean said:

No doubt the people of San Francisco will find ground for hope and encouragement in the progress that has been made toward the desired end of adjusting all building trades disputes in this community upon the basis of voluntary arbitration before an impartial tribunal set up by the parties immediately at interest.

The San Francisco Chamber of Commerce has labored earnestly to bring about a fair and reasonable understanding by the employers and employees in the building trades, and it is the hope and expectation of the chamber that, if the agreement thus far arrived at shall go forward to its logical conclusion, we will have provided a means by which the interests of all concerned in building operations in this city will be safeguarded and placed beyond the probability of destructive misunderstanding.

It is the belief of the Chamber of Commerce that the principle of voluntary arbitration holds a reasonable solution of all disagreements between the employer and employee involving questions of hours, wages and working conditions, and it is the hope of the chamber that this method of handling labor matters in San Francisco will eventually apply with full force to all kinds of employment.

What has been accomplished in the building trades situation is a distinct step in advance, and it seems to us that the general public, which is always a party at interest in labor matters should join with the employer and employee in viewing with satisfaction the approach of the day when all labor controversies in this city, and in the country at large, will be adjusted and settled by the method of voluntary arbitration that has been agreed upon by those engaged in the local building trades.

It is within the knowledge of everyone that strikes and lockouts are necessarily harmful, not only to the participants but to the community at large; and this being so, it should be the constant endeavor of all good citizens to bring about a better means of accommodating differences that may arise anywhere within the broad field of labor.

Credit Due Builders' Journal

The Builders' Journal, 142 Berkeley street, Boston, should have been credited with the article, "Skilled Mechanics Needed," which appeared in the Architect and Engineer of December, 1920. The oversight was due to failure of another publication, from which the extract was taken, to give proper credit.

The Beginning of Wisdom

By ERNEST IRVING FREESE.

He was in a hurry.
 And his name is Legion.
 He saw an ad. in the paper.
 About a new tract that was to be opened up.
 The streets were all laid out.
 The sidewalks were all in.
 Seventeen car-lines were within walking distance.

* * *
 The ad. said so.
 So he bought a lot.

* * *
 IN A HURRY.

* * *
 Then went out and looked at it.

* * *
 IN A HURRY.

* * *
 The seventeen car-lines were within walking distance.

Same as Mt. Whitney.
 Or Chicago.
 The streets were all laid out—by a sign writer.
 The sidewalks were all in

Ruins.
 But the man was in a hurry
 So he went to a builder to build him a house.

* * *
 IN A HURRY.

* * *
 The builder was an arch-ec-lect.
 Who drew his own plans.

* * *
 IN A HURRY.

* * *
 And he built the house.

* * *
 IN A HURRY.

* * *
 And got his money.

* * *
 IN A HURRY.

* * *
 And the man, whose name is Legion, moved into the house.

* * *
 IN A HURRY.

* * *
 And the foundations began to settle. The floors began to sag. The doors and windows began to creak and rattle. The woodwork began to warp and split. The plastering began to crumble. The paint began to peel. The roof began to leak.

* * *
 And the man, whose name is Legion, began to think.

* * *
 In a leisnrely manner.

* * *
 AND THAT WAS THE BEGINNING OF WISDOM.

School Number

A special school number of the Architect and Engineer will be published in March. So many of the cities and towns of California are building new schools, some of which have been started and others contemplated, that there are an unusually large number of good examples of school house design available for publication. The work shown will be selected from accepted designs of architects in Southern California, Oakland, Sacramento, Fresno, Richmond, San Francisco, Berkeley and other cities.

Electrical Department

Electricity in Mud Houses of the Southwest

By HARRY S. BRADLEY, in the Journal of Electricity.

THERE is no reason why sound, practical, livable homes cannot be built from adobe mud blocks any more than there is reason for not constructing them of brick, concrete, or any other good building material. In California, Arizona and Old Mexico, we find numerous structures which are evidence of their durability as a permanent and substantial building material, many of them having withstood the elements for upwards of one hundred and fifty years, without showing any noticeable signs of depreciation. Even the old Babylonian walls were built of sun baked mud blocks, and we are told that some of these old blocks are still intact, and clearly indicate the trade marks of those ancient builders.

Adobe built homes, if properly waterproofed, and finished with stucco which prevents them from absorbing moisture, are practically indestructible so far as natural

disintegration is concerned. They will stand more than the average amount of wear, and in case of damage from any

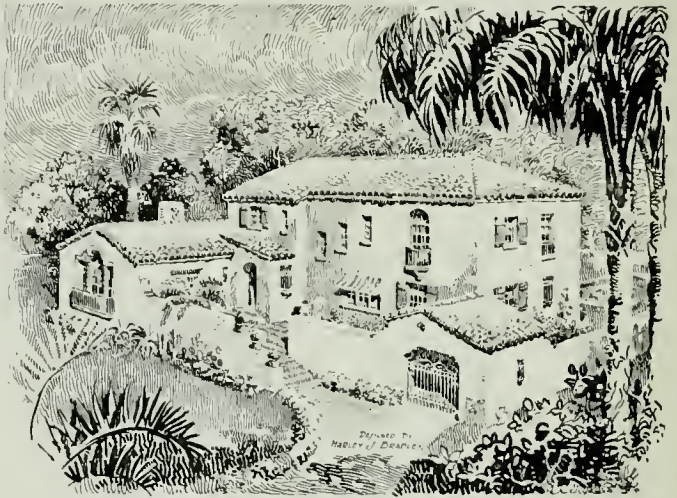

SKETCH OF ELECTRICAL HOME, LOS ANGELES

Designed by Harley S. Bradley

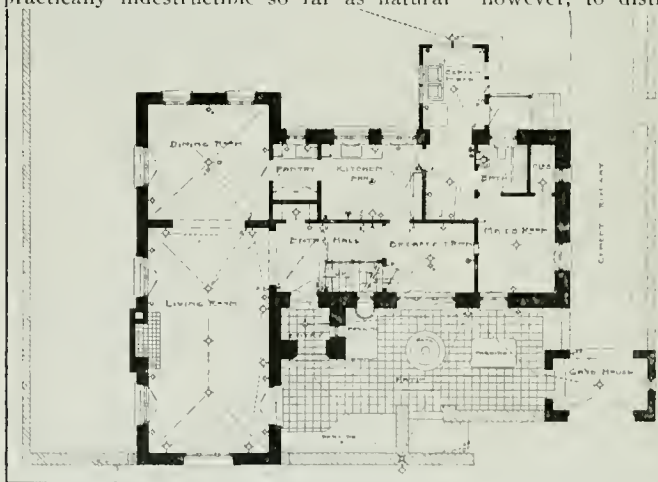

FIRST-FLOOR PLAN, ELECTRICAL HOME, LOS ANGELES

Designed by Harley S. Bradley

cause the walls may very easily be repaired with stucco. They should be reinforced with concrete lintels and plates, however, to distribute the floor and roof loads uniformly over the entire area of the wall surface. The first floor loads should be carried direct to the foundations, independent of the walls. Pine lumber should never be permitted to rest against the adobe walls, unless it has been first soaked with creosote, dead oil, or other similar material to prevent dry rot. The bearing plates should be of redwood, cypress or other water resisting wood, and should be securely bolted to the concrete plates.

At the present time we are constructing "The Adobe Electrical

Home," a two-story structure, in the New Windsor Square district of Los Angeles. Unlike the old Spanish adobe houses in Southern California, this home incorporates in its construction all the most modern electrical features of present-day building methods, including 117 outlets, 37 of which are convenience outlets of the latest plug-in type for the efficient use of all household electrical appliances and labor saving devices, underground electrical service and complete telephone wiring.

This home will be completely furnished and decorated, "ready to live in." . . . The home will be equipped by the electrical industry with about fifty of the very latest and most practical household appliances, which can be seen in actual operation.

Surrounding the home will be a very elaborate Spanish garden, which has been designed and planted by the Beverly Hills Nurseries.

SPECIAL ADVANTAGES OF ADOBE CONSTRUCTION

Every consideration has been given to practical convenient features and artistic simplicity of design, rather than to more

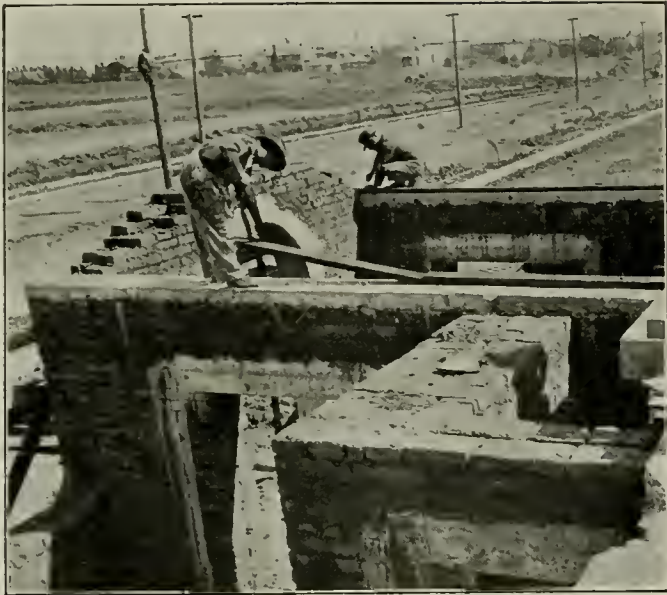

LAYING THE ADOBE BLOCKS FOR ELECTRICAL HOME,
LOS ANGELES

elaborate and necessarily more expensive details. We also required a type of construction that would keep the house warm in winter, cool in summer, sound-proof, and one which would best withstand earthquake shocks without danger of fractured walls. We therefore decided upon adobe construction as the most practical and indigenous material suitable to the climate and conditions of California.

Adobe blocks are more resilient than any other building material that I know of, and therefore will stand severe shocks without cracking or impairing the strength of the walls. There is but little difference in the compressive strength of a well seasoned adobe block and that of common burnt brick, and when these blocks are dried they become an almost perfect insulation. Adobe construction also lends itself admirably to the Spanish type of design so well suited to the atmosphere of California. Deep reveals, large plane surfaces and arched openings, may be constructed at slight expense.

(Concluded on page 112)



ELECTRICAL HOME, LOS ANGELES

Designed by Harley S. Bradley

American Institute of Architects

(ORGANIZED 1857)

OFFICERS FOR 1920-21

PRESIDENT.....HENRY H. KENDALL, Boston
 FIRST VICE-PRESIDENT.....CHARLES A. FAVROT,
 New Orleans, La.
 SECOND VICE-PRESIDENT.....WM. B. FAVILLE,
 San Francisco
 SECRETARY...W. STANLEY PARKER, Boston, Mass.
 TREASURER.....D. EVERETT WATO, New York

San Francisco Chapter

PRESIDENT.....G. A. APPLGARTH
 VICE-PRESIDENT.....EARNEST A. COXHEAD
 SECRETARY-TREASURER.....J. S. FAIRWEATHER

DIRECTORS

SYLVAIN SCHNAITTACHER, for three years,
 MORRIS M. BRUCE, for three years,
 GEORGE W. KELHAM (to fill the unexpired term
 of Mr. Wm. Otis Raiguel, resigned).

Southern California Chapter

PRESIDENT.....EDWIN BERGSTROM
 VICE-PRESIDENT.....HENRY F. WITHEY
 SECRETARY.....R. GERMAIN HUBBY
 TREASURER.....ROBERT H. ORR

Executive Committee

A. M. EOELMAN D. C. ALLISON S. B. MARSTON

Portland, Ore. Chapter

PRESIDENT.....W. C. KNIGHTON
 VICE-PRESIDENT.....JOHN V. BENNES
 SECRETARY.....FOLGER JOHNSON
 TREASURER.....O. R. BEAN
 TRUSTEES.....{ ELLIS F. LAWRENCE
 { JOSEPH JACOBBERGER

Washington State Chapter

PRESIDENT.....CHARLES H. ALDEN, Seattle
 1ST VICE-PRESIDENT.....JAMES H. SCHACK, Seattle
 2D VICE-PRESIDENT.....GEORGE GOVE, Tacoma
 3D VICE-PRESIDENT.....L. L. RANO, Spokane
 SECRETARY.....F. A. NARAMORE, Seattle
 TREASURER.....EARL G. PARK, Seattle
 DIRECTORS.....{ A. H. ALBERTSON
 { C. H. BEBB
 { G. C. FIELD

California State Board of Architecture

NORTHERN DISTRICT

PRESIDENT.....CLARENCE R. WARD
 SECRETARY-TREASURER.....SYLVAIN SCHNAITTACHER

Members

J. R. MILLER EDWARD GLASS J. J. DONOVAN

SOUTHERN DISTRICT

PRESIDENT.....JOHN PARKINSON
 SECRETARY-TREASURER.....A. M. EDELMAN

Members

W. H. WHEELER MYRON HUNT W. J. DODD

San Francisco Architectural Club

President.....T. L. Pfeuger
 Vice-President.....Wm. Watson, Jr.
 Secretary.....L. A. Bryant
 Directors—Pas. Brouchoud, F. G. Monk, S. D.
 Willard.

San Francisco Society of Architects

President.....W. C. HAYS
 Vice-President.....LEWIS P. HOBART
 Secretary-Treasurer.....H. H. GUTTERSON
 Directors.....{ GEO. A. LANSRUGH
 { JOHN REID, JR.

Washington State Society of Architects

PRESIDENT.....HENRY H. JAMES, Seattle
 1ST VICE-PRES.....CLAYTON D. WILSON, Seattle
 2D VICE-PRES.....JULIUS A. ZITTEL, Spokane
 3D VICE-PRES.....WATSON VERNON, Aberdeen
 4TH VICE-PRES.....RICHARD V. GOUGH, Okanogan
 SECRETARY.....EGGAR BLAIR, Seattle
 TREASURER.....L. L. MENDEL, Seattle
 TRUSTEES—H. H. JAMES, FRANK FOWLER, A. WARREN
 GOULD, W. J. JONES, R. H. ROWE, all of
 Seattle.

American Society of Landscape Architects

Pacific Coast Chapter

PRESIDENT.....W. D. COOK, JR.
 H. W. Hellman Bldg., Los Angeles, Calif.
 VICE-PRESIDENT.....STEPHEN CHILDS
 Fairmont Hotel, San Francisco, Calif.
 SECRETARY-TREASURER.....E. T. MISCHE
 Henry Bldg., Portland, Oregon

Tacoma Society of Architects

PRESIDENT.....Roland E. Borhek
 VICE-PRESIDENT.....Earl Dugan
 SECRETARY AND TREASURER.....A. J. Russell

San Diego Architectural Association

PRESIDENT.....WM. TEMPLETON JOHNSON
 VICE-PRESIDENT.....ROBERT HALLEY, JR.
 SECRETARY-TREASURER.....E. C. DECKER

San Joaquin Valley Ass'n of Architects

PRESIDENT.....E. P. BROWN
 VICE-PRESIDENT.....F. V. MAYO
 SECRETARY-TREASURER.....JOSEPH LOSEKANM

American Society of Civil Engineers

San Francisco Association

PRESIDENT.....M. M. O'SHAUGHNESSY
 1ST VICE-PRES.....W. L. HUBER
 2ND VICE-PRES.....F. R. MUHS
 SECRETARY AND TREASURER.....NATHAN A. BOWERS

BOARD OF DIRECTORS

W. L. HUBER
 F. R. MUHS M. M. O'SHAUGHNESSY
 E. J. SCHNEIDER NATHAN A. BOWERS
 Address all communications to the secretary, 502
 Rialto Bldg., San Francisco.

Southern California Association

President.....H. W. Dennis
 First Vice-President.....R. J. Reed
 Second Vice-President.....F. D. Howell
 Treasurer.....E. R. Bowen
 Secretary.....F. G. Dessery
 DIRECTORS—H. W. Dennis, Ralph J. Reed,
 F. D. Howell, E. R. Bowen, F. G. Dessery, G. G.
 Anderson, W. K. Barnard.
 Address all communications to Secretary F. G.
 Dessery, 619-20 Central building.

American Association of Engineers

PRESIDENT.....L. K. SHERMAN
 FIRST VICE-PRESIDENT.....H. O. GARMAN
 SECOND VICE-PRESIDENT.....A. B. MCDANIEL
 R. W. BARNES.....Portland
 FREDERIC BASS.....Minneapolis
 B. A. BERTENSHAW.....Cincinnati
 W. C. BOLIN.....Chicago
 RAYMOND BURNHAM.....Chicago
 C. E. DRAVER.....Secretary
 National Headquarters, 63 E. Adams St., Chicago

SAN FRANCISCO CHAPTER

PRESIDENT.....G. CHESTER BROWN
 FIRST VICE-PRESIDENT.....W. H. PHELPS
 SECOND VICE-PRESIDENT.....L. D. HOWLAND
 TREASURER.....R. E. DODGE
 SECRETARY.....F. T. AMWEG
 Permanent address, 960 Pacific Bldg.

LOS ANGELES CHAPTER

PRESIDENT.....CARL A. HEINZE
 FIRST VICE-PRESIDENT.....H. Z. OSBORNE, JR.
 SECOND VICE-PRESIDENT.....MYRON HUNT
 TREASURER.....E. H. MERRILL
 SECRETARY.....WILLIS S. PEPPER
 Permanent address, 625 Metropolitan Bldg.,
 Los Angeles.

With the Architects

Building Reports and Personal Mention of Interest to the Profession

Bank Additions

Mr. Smith O'Brien, San Francisco, is preparing drawings for extensive alterations and additions to the banking quarters of the Humboldt Bank, which institution reports having had the most prosperous year in its existence in 1920.

Auto Sales Building

Plans are being drawn by Mr. D. C. Coleman, French Bank building, San Francisco, for a two story concrete auto sales building and garage, to cost \$165,000, and to be built at McAllister street and Van Ness avenue for the Pioneer Motor Company. Mr. Wm. Helbing is the owner.

Apartment Houses

Schirmer-Bugbee Company of Oakland have two apartment houses on the boards, one a \$90,000 three story structure facing Lake Merritt, and a \$20,000 four apartment building to be built on Lakeshore avenue for Mr. A. W. Keil.

Chamber of Commerce Building

Mr. E. C. Hemmings of Sacramento has been commissioned to prepare plans for the Chamber of Commerce building at Sacramento. There is \$80,000 available for the structure.

Parochial School

Mr. A. C. Martin, Higgins building, Los Angeles, is preparing plans for a brick veneer school and auditorium at San Bernardino, to cost \$100,000. Rev. N. Conneally is director of the school.

Apartment House

Mr. S. Heiman has prepared plans for a two story frame and brick veneer apartment house to be built on Dolores street, north of Fifteenth street, San Francisco, for Mr. M. Saroff. The estimated cost is \$35,000.

Market Building

Messrs. Maston and Heard, Foxcroft building, San Francisco, have completed plans for a market building to be built at Corning, Tehama county, for Mr. J. L. Donovan of that city.

Personal

MR. ERNEST J. KUMP, architect of Fresno, announces a combination of talent in his office, under the title of the Ernest J. Kump Company, Architects and Construction Managers, the personnel being made up of Mr. Kump, Mr. Arthur O. Johnson, formerly head draftsman for Mr. Henry H. Meyers, architect of San Francisco, and Mr. H. S. Brindle, superintendent of construction.

MESSRS. LESCHER & KIBBEY of Phoenix, Ariz., announce that Mr. Leslie J. Mahoney, who has been connected with their office for five or six years, has been taken into the firm, which will hereafter be known as Lescher, Kibbey & Mahoney. Mr. Mahoney was for a number of years connected with the office of Mr. A. C. Martin in Los Angeles.

MESSRS. CARRERE and HASTINGS, architects, announce that Messrs. R. H. Shreve, William F. Lamb and Theodore E. Blake will in the future be associated with their office, which is at 52 Vanderbilt avenue, New York City. They will practice architecture under the firm name of Carrere and Hastings, architects, Shreve, Lamb and Blake, associated.

The engagement is announced of Miss Elah Hale, graduate of the Department of Architecture of the University of California, and Mr. William C. Hays, professor of architecture in the same institution. An announcement party was given by Mrs. Stafford Jary, followed by a kitchen shower by Mr. and Mrs. Warren Perry on February 6th.

MR. WHITNEY WARREN, architect, who designed the Grand Central terminal and other large buildings in New York, has been appointed to take charge of the architectural reconstruction of the famous University of Louvain, which was destroyed in 1914 in the German invasion of Belgium.

MESSRS. WALKER & EISEN have moved their offices from the Hibernian building to the Pacific Finance building, recently completed at the southwest corner of Sixth and Olive streets, Los Angeles.

MR. WILL D. SHEA has moved his offices from the Marston building to the sixteenth floor of the Chronicle building, San Francisco.

MESSRS. MORROW and GARREN have moved their offices to the sixteenth floor of the Chronicle building, San Francisco.

Southern California Chapter, A. I. A.

According to President Edwin Bergstrom's annual report, read at the January meeting, the year 1920 was a most satisfactory one for Southern California Chapter, A. I. A. The chapter will be represented at the Institute convention in Washington next May by Messrs. Bergstrom, Myron Hunt and Octavius Morgan. The president has appointed the following committees to serve during the year:

Institute and Chapter Affairs Committee—Robert H. Orr, chairman; H. M. Patterson, secretary; John P. Krempel, Octavius Morgan and J. T. Zeller.

Ethics and Practice Committee—A. M. Edelman, chairman; S. Tilden Norton, secretary; John Parkinson, O. W. Morgan and Alfred W. Rea.

Education and Publicity Committee—D. C. Allison, chairman; Myron Hunt, secretary; Reginald Johnson, Carleton M. Winslow and W. J. Dodd.

Membership Committee—R. Germain Hubby, chairman; A. F. Rosenheim, secretary; William M. Clarke, Charles F. Plummer and Clarence E. Noerenberg.

Public Service Committee—Henry F. Withey, chairman; Harwood Hewitt, secretary; J. J. Backus, J. E. Allison and Sumner Hunt.

Affiliated Societies and Allied Arts Committee—S. B. Marston, chairman; Elmer Grey, secretary; J. C. Austin, F. Pierpont Davis and Edward C. Taylor.

Guest of Washington Chapter

Mr. John J. Donovan, formerly school architect for the city of Oakland, was the guest of Washington State Chapter, A. I. A. at its 25th annual meeting January 6th. Mr. Donovan gave a twenty minutes talk describing his experiences as a practicing architect in Oakland, both privately and for the city government. Mr. Donovan related a number of amusing incidents in connection with the construction of the municipal auditorium, one of which was the designing of a truss that would carry elephants. President Alden of the Washington chapter reviewed his trip east to St. Louis, where he attended a meeting of the Institute directors.

Designs Many Homes

Mr. Earl Bertz, architect in the Foxcroft building, San Francisco, is preparing plans for a dozen more fine homes to be erected in the Sea Cliff district of San Francisco, for Allen & Co. More than two blocks of these homes were built in 1920 from Mr. Bertz's plans.

Drawings have also been made in the same office for a reinforced concrete store building on Bush street, near Powell, San Francisco, for Mrs. A. E. Cavanaugh, and for extensive alterations of a frame residence into modern apartments.

American Architects Invited to Exhibit in Paris

By invitation of the Société des Artistes Français, of which M. Laloux is president, and in collaboration with the French Department of Fine Arts, there will be held an exhibition of American architecture in the Salon des Artistes Français in Paris, opening on May 1st and lasting for about two months.

The exhibition, which has been arranged through the offices of M. Maurice Casenave, Director General of French Services in the United States, is being prepared under the direction of the Committee on Foreign Building Co-operation of the American Institute of Architects.

Architects desiring to exhibit drawings or photographs are requested to communicate with Mr. Julian Clarence Levi, secretary of the committee, 105 West Fortieth street, New York City, who will furnish information in regard to time of delivery of exhibits, etc.

National Registration Board

Mr. Sylvian Schnaittacher, architect of San Francisco, attended the recent meeting of the National Council for Architectural Registration Boards, held in St. Louis, as a representative of the California State Board of Architecture, Northern District. An outline of the board's function is given elsewhere in this issue. Undoubtedly the operation of this National Council is destined to be the biggest thing that has been done for some years to further the architectural profession. It is believed that when the plan is in working order architects will begin to realize and appreciate the exceptional benefits to be derived from membership in recognized architectural societies.

S. F. Architectural Club Officers

The newly elected officers of The San Francisco Architectural Club were regularly installed for the ensuing term on January 5th, as follows:

President, T. L. Pflenger.

Vice-President, Wm. Watson, Jr.

Secretary, Leland A. Bryant.

Treasurer, Wm. K. Dunning.

Directors—Pas. Brouchoud, Fred G. Munk and Stanton D. Willard.

The retiring president, Mr. Harry Michelson, was presented with a past presidents' jewel.

Architectural Designers Wanted

Applications will be received until June 1, 1921, for permission to participate in an examination by the United States Civil Service Commission, Washington, D. C., for architectural designers in the Philippine service, at a salary of \$4000 a year.

Death of Mr. Oswald Speir

Mr. Oswald Speir died on the train en route from New York to Chicago, on February 2, 1921. Mr. Speir will be remembered as being connected for many years with the organization of Gladding, McBean & Co. in San Francisco, and for the last three or four years their representative in Los Angeles. In June of 1920 Mr. Speir was selected to serve as the Managing Director of the National Terra Cotta Society, with offices in New York City, and it was while on his way to attend the annual meeting of this Society in Chicago that he passed away.

Concrete Dormitory

Mr. Robert H. Orr, Van Nuys building, Los Angeles, and 75 Post street, San Francisco, is preparing plans for a dormitory, the first unit of a group of school buildings to be erected at Los Angeles for the California School of Christianity. The building will be of concrete, and will cost \$150,000.

Hardwood Lumber Company to Build

The Strable Hardwood Company, 237 First street, Oakland, has outgrown its present quarters and will build a new plant, including a large warehouse, on property owned by the company in Emeryville. Construction is to start very soon.

Theatre for Mission District

Mr. L. M. Hoyt has purchased the property, 125x128, extending back from Mission street to Bartlett, adjoining his factory at 2630 Mission street, San Francisco, as a site for a new moving picture and vaudeville theatre.

Bank Plans Completed

Mr. J. W. Dolliver, Royal Insurance building, San Francisco, has completed plans for alterations to the Bank of San Rafael. The same architect is preparing plans for a \$10,000 frame garage for a client in Ross.

San Luis Obispo School Bonds Carry

Bonds amounting to \$373,000 for new school buildings have been voted at San Luis Obispo. Preliminary plans for the buildings have been made by Messrs. John J. Donovan and Orville L. Clark.

Oakland Orpheum Site

It is reported on good authority that the new Oakland Orpheum will be built on upper Broadway, north of Seventeenth street.

Vallejo School Bids Rejected

Bids for the Woollett & Lamb school building at Vallejo have been rejected and the work will be readvertised later. Contracts on the high school have been let.

Architects Win Suit

Messrs. Stewart and Moffet, architects of Philadelphia, recently won a suit for \$5000 from a school board which claimed that the plans provided for a building costing one hundred thousand dollars when the board required a building to cost seventy thousand. The court decided that the board delayed seeking bids so long that labor and material had advanced from costs prevailing when plans were drawn.

Richmond Architect Busy

Mr. Jas. T. Narbitt is busy on plans for the new Richmond schools, including a \$200,000 high school group, in addition to considerable private work. Mr. Narbitt will be the architect of a bank and office building for the Richmond Savings Bank, and he will also design a hollow tile school house for the Danville School District.

Certificates to Practice

The California State Board of Architecture, southern district, has granted certificates to practice architecture to the following: Messrs. Alfred F. Priest, 618 Fay building; Benj. J. Bloser, 523 Consolidated Realty building; F. DeBonne, with L. A. Parker, 472 Pacific Electric building, and Wm. A. Edwards, Santa Barbara.

Santa Clara High School

Mr. W. H. Weeks, 75 Post street, San Francisco, has completed plans for the Santa Clara high school, and bids will be advertised at once. There will be two buildings. Construction will be frame and brick veneer with tile roof. Bonds amounting to \$235,000 have been voted and sold.

To Design \$100,000 Church

Mr. C. W. Bulger of Dallas, Texas, has been commissioned to prepare plans for a brick church to be erected on the northeast corner of Park and Columbia streets, Portland, for the First Christian Society, to cost \$100,000.

College Dormitory

Mr. Wilson J. Wythe of Oakland is preparing plans for a girls' dormitory, to cost \$200,000 and to be the first unit of a group of new buildings for the College of the Pacific, San Jose.

Big Theatre for Portland

Messrs. Ackerman & Harris have announced they will start construction within sixty days on a vaudeville theatre, 100x200, in the city of Portland, at a cost ranging from \$750,000 to \$1,000,000.

\$400,000 School Group

Mr. Norman F. Marsh, Los Angeles, has been selected architect of a group of high school buildings at Reedley, Fresno county. Bonds for \$400,000 will be voted in March.

Material Prices in the East

Mr. Allen E. Beals of Dow's reports on "Building Materials, Supply and Prices," in an address before the autumn meeting of the New York State Association of Architects held in New York City on November 12, presented some interesting figures which we quote herewith:

Year	Cost of Buildings Constructed	Average Cost Per Sq. Ft.	Sq. Feet Built
1911.....	\$ 926,499,700	\$1.59	605,000,300
1912.....	1,027,515,200	1.63	630,000,400
1913.....	980,971,600	1.61	609,300,000
1914.....	891,845,500	1.55	577,000,400
1915.....	931,937,300	1.52	613,100,000
1916.....	1,103,160,900	1.82	624,000,800
1917.....	816,941,000	2.27	358,000,000
1918.....	492,163,900	2.65	185,700,000
1919.....	1,467,821,300	3.20	458,600,000
1920*.....	1,170,000,000	3.60	325,000,000
1919*.....	871,000,000	3.20	278,000,000

*First nine months.

Mr. Beals concluded his address with the following observation:

"... The present position of materials men reminds me of the mules which they send down into mine shafts and bring up once every two years or so to clean. When a mule is brought to the surface, into the sunlight, they humanely attach blinders over his eyes.

"After the war the materials men were brought up to the sunlight, but there were no blinders and the total result of that is just this: Your client unless he acts shortly on any proposed building scheme will be shut off from the market. Materials are at their bottom prices now. Cancellations have stopped, and that is significant. There will be no lower levels. I say that with a very full sense of every factor which goes into building materials.

"You have your choice between the 1912 'shoestring' and loose credits, and between present conditions and tight credits. The latter is the better. Tight credits are an incentive, a help, a distinct advantage. Tight credits and the realization that the present prices are the real and permanent prices are what you should think over and having thought it over, you will go to your client and say this:

"If you postpone building, you are in danger of finding yourself shut off from the market."

It is thus evident that present conditions as to the material market in the vicinity of New York are no different than architects find them in Chicago, comments the Monthly Bulletin of the Illinois Society of Architects. And we might add—in San Francisco, too.

Electricity in Mud Houses

(Continued from page 107.)

LOW COST OF BUILDING

From the standpoint of economy, a good idea of cost may be had from the following comparison: With common standard brick, at \$20 per M and labor and mortar for laying same at \$20 per M, the cost of brick in a straight run wall will total \$40 per M, making approximately 48 cubic feet of finished wall, whereas adobe blocks 4 in. thick, 12 in. wide and 24 in. long, will cost \$65 per M and labor and lime for laying same at \$40 per M will total \$105 per M, and lay up an area of approximately 800 cubic feet. From these calculations, which are based on practical estimating, and figuring a bricklayer's wages at \$1.50 per hour, we find the cost of finished brick wall at 83c per cubic foot, and adobe walls at 13c per cubic foot. This estimate, however, is based upon using excavated adobe from the lot on which the building is to be erected.

Formerly, the chief objection to adobe construction was the usual disintegration of the walls at the grade line, due to the constant absorption of moisture. This error, together with the matter of an insufficient plaster bond, have been overcome by water-proofing the concrete foundations with liquid coal tar and extending them well up above the grade line, and providing a dove-tail key on the surface of the blocks as a bond for the plaster.

It is my candid opinion that when the merits of adobe construction become more generally understood, and when ordinances have been established to govern this method of construction in one-story buildings, permitting only the use of approved tested blocks, then adobe construction will become a universal type for California homes, which will mean more artistic and more practical homes at less cost.

Office Building

The Pacific Gas and Electric Company has announced it will build a five story office building at Seventeenth and Clay streets, Oakland.

HARDWOOD HEADQUARTERS

ASH-BASSWOOD-BIRCH
AROMATIC RED CEDAR
COTTONWOOD-ELM-HOLLY
SOUTHERN RED GUM
HICKORY-LAUREL-MAPLE
DREIGN-MAPLE-PLUM-GUM
QUARTERED OAK
WYBROOK BENDING OAK
POPLAR--WALNUT



BOXWOOD-ERICHY-IRONBARK
JUNIBERO-KOA-SPANISH CEDAR
LIGNUMVITAE-MAHOGANY
ROSEWOOD-TEAK-RED BEAN
SPRITZ-GUM-CROSSAN WALNUT

LUMBER--TIMBER
HARDWOOD FLOORING
WYBRO VENEERED PANELS
DOWELS-TREENAILS-VENEERS

WHITE BROTHERS

FIFTH and BRANNAN STREETS SAN FRANCISCO, CAL.

Our New Trade Mark!

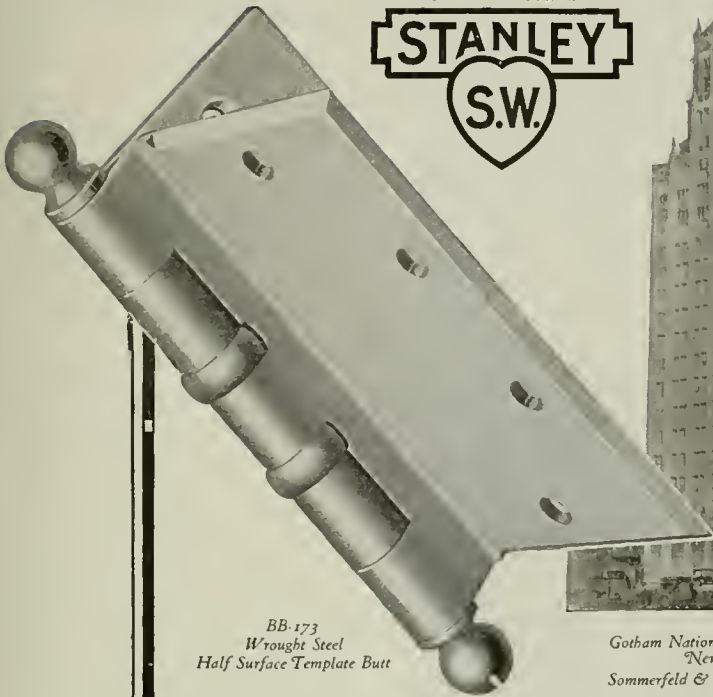

BB-173
Wrought Steel
Half Surface Template Butt

Gotham National Bank Building
New York
Sommerfeld & Stecker, Architects

Silent Testimony —

Silent, easy-swinging doors in another modern skyscraper will again testify to the superiority of

STANLEY

Ball Bearing Butts

The Gotham National Bank Building at Columbus Circle, New York City will be equipped with about 2000 Stanley Ball Bearing Butts--BB-856 and BB-173.

Send for Ball Bearing Butt Catalog AE-2

We have ready for distribution to architects, an architectural service sheet AE-2 featuring Storm Sash Hardware which will be mailed on request.

THE STANLEY WORKS

Main offices and plants:
NEW BRITAIN, CONN.

Branch Offices:

New York
Los Angeles

Chicago
Seattle

San Francisco
Atlanta

To remind you of our January advertisement



With the Engineers

Reports from the Various Pacific Coast Societies,
Personal Mention, Etc.

New Head of Engineers' Chapter

THE new president of San Francisco Chapter, American Association of Engineers, has many friends in the Bay Region, where he is known as the Chief Mining Engineer for the California Industrial Accident Commission. Mr. Brown has served as an engineer for the Associated



MR. G. CHESTER BROWN.
President, S. F. Chapter, A. A. E.

Oil Company, City and County of San Francisco, American Mines Company, Guggenheim Syndicate, Spokane Mining Company, East Side Canal Company, and since 1915 as the chief mining expert for the California Industrial Accident Commission.

The Engineer's Place in Preventing Accidents on Construction Work

An address was delivered by Mr. J. J. Rosedale, Construction Engineer, Industrial Accident Commission of California, before the San Francisco Chapter of the American Association of Engineers, at the Commercial Club, Merchants Exchange building, San Francisco, on January 4. Mr. Rosedale said, in part:

"At no time in the history of men was there a greater call for the engineer to take his place in the construction industry than today. Just as the doctor is trained to cure illness and prevent disease, so is the engineer trained to carry on safely construction projects and be the leader and director in this industry.

"In 1919, 5411 construction accidents were reported to the Industrial Accident Commission, of which 81 were fatal, 171 permanent and the remainder temporary disabilities.

"Most of these accidents it was learned by investigation and studying the reports, were preventable if everything had been done that should have been done.

"Accidents and wastes on engineering work can be eliminated if every engineer will do his bit in boosting the profession and get into the construction field—the place where he really belongs. An engineer can be a foreman at \$75 per week, a superintendent at \$450 to \$600 per month, a general manager of a construction company at \$10,000 to \$15,000 per year and a contractor or promoter at greater compensations.

"What the engineer needs is salesmanship. He needs to learn to sell his services. He has a very good product but does not know how to get it before the public. The general public does not appreciate his value because they do not know what he does for them; they haven't been informed that the engineer is largely responsible for our industrial progress and the general comfort of our modern civilization.

"Our last President made an effort to appoint a committee to revise the San Francisco building code. What we need is a live committee to investigate our building inspection departments in the entire State and try to persuade the public to replace building inspectors who are bricklayers, plasterers, carpenters or plumbers by engineers. What is the use of revising building codes if you do not have competent engineers in our cities to enforce them?

"There is a crying need for a State building code and an efficient corps of engineers and inspectors to enforce the safe construction of buildings, structures and other projects in this and every State in the union.

"This organization should take immediate steps to appoint a committee to assist the Industrial Accident Commission in drafting a State building code. It should also appoint committees on industrial and public safety.

ADVERTISING
the
 BEAUTIFUL



STORE BUILDING OF
 WILLIAM FILENE'S SONS &
 CO.
 BOSTON, MASS.
 D. H. BURNHAM & CO., Architects

Copyright, 1920, National Terra Cotta Society Drawing by Hugh Ferriss

THE architect, by virtue of his profession, believes in beautiful buildings and seeks to convey his belief to the public. The architect's buildings are his only advertisement of his creed and his ability.

In the case of the great Terra Cotta store building of William Filene's Sons & Co., illustrated above, the architect has done more—he has advertised the prominence, prestige and progressiveness of his client.

This building is a standing advertisement, too, of the beauty of the material in which it is designed—Terra Cotta: *Permanent, Beautiful, Profitable.*

The architect sees here a material specially adaptable to unit of design, to variety in color and texture, to plastic detail, to the most flexible execution of any style, historical or modern.

National Terra Cotta Society is telling these things to the public—is advertising the beautiful in architecture, as well as the permanent and profitable aspects, of building—in a series of pages which are attracting wide interest and attention in "The Literary Digest."

Architects will be interested in following this series.

NATIONAL TERRA COTTA SOCIETY is a bureau of service and information. Its publications cover not only the technical and structural use of the material but show, as well, examples of its application to buildings of various types.

Brochures of specific value, as indicated by their titles, will be sent to Architects on request addressed to National Terra Cotta Society, 1 Madison Avenue, New York City.

The School The Theatre The Garage The Store The Bank

These brochures consist of a selection of illustrations, with text and comment, showing Terra Cotta buildings of the respective types.

Terra Cotta—Standard Construction.

A valuable Technical Reference Work for Architects and Engineers.

TERRA COTTA
 Permanent Beautiful Profitable

"Much has been done in this State to prevent accidents on construction work, but there is still much to be done. This organization can do a great deal by assisting both the engineer to occupy his *place* in our industries and safeguard the enormous wastes and incompetent supervision of engineering work and co-operate with the Industrial Accident Commission in preaching and practicing the safety gospel."

Oregon Examiners Ask New Laws

Oregon State Board of Architect Examiners has submitted its annual report to the Governor. This report contains a suggestion through which smaller cities would be governed in the erection of buildings as is the practice at the present time in Portland. Some of the smaller cities have building codes, but they do not protect the public against unsafe buildings in matters of structural safety and sanitation. The suggestion is made in the report that a state building code be adopted, carrying with it administrative officers or providing that buildings be erected after plans and specifications prepared by registered architects or registered engineers only.

"The present architect's law states that any person or persons may prepare plans and specifications and erect buildings therefrom, provided they do not use the title architect.

"This safeguards the building public to the extent that persons employing registered architects, are assured that such persons have certain knowledge and skill as provided by law, but does not protect those who in their ignorance seek to erect buildings without the services of persons qualified by law, with sometimes disastrous results."

The report also states that there has been some criticism of the present architect law, for the reason that it prohibits landscape architects and naval architects from practicing under their respective titles within the State without qualifying as architects under the general title.

The membership of the board is constituted as follows: Messrs. William C. Knighton, Portland, president; J. T. Wicks, Astoria, vice-president; Morris H. Whitehouse, Portland, treasurer; Lee A. Thomas of Bend, and Frank C. Clarke of Medford. George M. Post, Portland, secretary, is not a member of the board.

January Meeting Los Angeles Chapter, American Association of Engineers

Installation of officers elected to serve for the year 1921 took place following announcement of the result of the letter ballot, at the annual meeting of Los Angeles Chapter, American Association of Engineers, January 14. Mr. Carl A. Heinze is the new president. He is connected with the

power bureau of the city of Los Angeles as assistant electrical engineer in charge of the maintenance of the distributing system. Mr. Frank H. Joyner, retiring president, was presented with a gold watch fob, suitably engraved.

The other newly elected officers are: First vice-president, Mr. H. Z. Osborne, Jr., chief engineer Los Angeles Board of Public Utilities; second vice-president, Mr. Myron Hunt, architect; treasurer, Mr. E. H. Merrill; secretary, Mr. Willis S. Pepper; directors, Messrs. Wm. D. Armstrong of Los Angeles County Road Department; H. C. Ferry, civil engineer with the Union Oil Co.; F. C. McMillan, bridge engineer of Los Angeles County Flood Control Department, and W. W. Patch, Division Engineer, State Highway Department. The new auditing committee consists of A. L. Sonderregger, R. H. Holbrook and Wm. S. Bascom.

Reports of officers and committees were received. The secretary's report showed the total membership of the Chapter December 31, 1919, was 448, and December 31, 1920, it had increased to 860. The Chapter now has about 575 certified and junior members.

Portland Hospital

Messrs. Lawrence and Holford, architects in the Chamber of Commerce building, Portland, Oregon, have completed plans for the first unit of the Wilcox Memorial Hospital, consisting of a maternity ward, and they are now busy on plans for a second unit which is to cost in excess of \$200,000.

Bank Addition

Construction will start immediately from plans by Mr. Geo. W. Kelham on a substantial addition to the Anglo London Paris Bank at Market and Sansome streets, San Francisco. The work will be carried on jointly by McLeran & Peterson and the P. J. Walker Company.

San Jose Garage

Mr. Jens C. Petersen, architect in the People's Savings Bank building, Sacramento, has completed plans for a \$70,000 concrete and brick auto sales building and garage for Messrs. Powell & Smith of San Jose. The owners will take bids and award a contract within thirty days.

Two Movie Theatres

Plans have been completed by Mr. A. W. Cornelius, San Francisco, for two T. & D. moving picture theatres, one at Richmond and the other at Salinas. A contract for building the latter has been let to Ruegg Bros. of San Francisco for \$60,000.

Start construction early - Move materials NOW

Avoid the Construction Difficulties of 1920

AN unprecedented demand for construction materials overhangs the market. Once released, this demand can be met satisfactorily only through cooperation of the various agencies interested.

Owners and public officials must mature plans quickly, so that

**Contractors can order material early
Dealers can build up stocks
Manufacturers can ship promptly, and
Railroads can handle business
offered quickly.**

Had such a policy prevailed throughout the period since the armistice, the difficulties experienced in carrying on construction work during 1920 would have been considerably lessened, if not entirely avoided. Contracts for an enormous peace-time construction program were awarded too late in 1919 to permit of completion during that year. This deferred demand came upon an unprepared market and was carried over into 1920, only to be still further hampered by the large construction program of that year. Not only was the greater portion of 1919 lost, but the construction industry impeded by railroad congestion was thrown into such turmoil in 1920 that only a cessation of contract letting could clear the situation.

Five years' accumulation of construction still awaits contract letting. If such contracts are awarded early in 1921 and construction proceeds in an orderly, intelligent and efficient manner, material manufacturers and railroads can meet the situation. Unless this plan is followed, difficulties even more serious than those of 1920 can be expected. You share with others a measure of responsibility in preventing a recurrence of such a situation.

Due to handicaps beyond its control, the cement industry operated at only approximately 70 per cent of capacity during 1920. Notwithstanding earnest and sustained effort on the part of cement manufacturers, many users were disappointed due to their inability to get shipments when and where wanted.

Transportation is the neck of the bottle regulating capacity of industry and distribution of its products. Cement is now available everywhere. Manufacturing capacity has always been equal to any calls made upon it unless demand has been concentrated within comparatively short periods.

There's no time like Now to move materials.

PORTLAND CEMENT ASSOCIATION

Atlanta	Detroit	Los Angeles	Parkersburg	San Francisco
Chicago	Helena	Milwaukee	Pittsburgh	Seattle
Dallas	Indianapolis	Minneapolis	Portland, Oreg.	St. Louis
Denver	Kansas City	New York	Salt Lake City	Vancouver, B. C.
Des Moines				Washington

Start construction early - Move materials NOW



BUILDING BUSINESS

CALIFORNIA'S OLDEST NATIONAL BANK HAS BEEN A VITAL FACTOR IN THE UPBUILDING OF SAN FRANCISCO AND THE ENTIRE WEST.

WHEN LAYING PLANS FOR THE FUTURE OF YOUR BUSINESS CONSULT THE OFFICERS OF THIS INSTITUTION

THE FIRST NATIONAL BANK OF SAN FRANCISCO

Affiliated with

FIRST FEDERAL TRUST COMPANY

Combined Resources \$60,473,521.88

The Contractor

Should the Builder be Licensed?*

AN ARGUMENT IN THE NEGATIVE

By C. A. CRANE,

Secretary, General Contractors' Association of New York.

IF a State license were to be a guarantee of integrity and responsibility, we would be for it. It would add nothing to the reputation of the reliable builder, but would be exploited by the irresponsible holder as evidence of fitness he did not possess. The answer of those favoring license will be that the requirements and examinations should be so strict and searching that none but the reliable could qualify. Again we say if that could be assured, we'd be for it. Examinations, however, do not develop proof of reliability and integrity; they can do no more than reveal a certain amount, more or less, of theoretical knowledge with a statement of the applicant's experience on which his practical knowledge is based.

Some years ago an enterprising reporter took a series of civil service examinations in New York for professional and mechanical positions in the city's service. Without any practical experience in any of them he passed every test with a high average, and was offered appointments to several positions, not one of which he was qualified to fill. As we recall, he passed at the head of the list in the plumbers' examination, although he had never wiped a joint in his life and didn't know red lead from solder. His purpose was to write a story exposing the fallibility of civil service examinations and showing that they were no protection against the employment of incompetents. Positions of higher responsibility, such as chief engineer, are not usually in the classified civil service. Such appointments are made not as the result of an

*A. C. Bulletin.

ARTHUR BROWN

INTERIOR DECORATOR

212 Foxcroft Building
SAN FRANCISCO

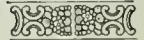

Fine Art
Fabric Designs
Domestic and
Foreign Wall
Hangings
Japanese
Grass Cloth

Telephone
Kearny 5879



TRANSMISSION EQUIPMENT

For Mill or Factory

Pulleys - -	Shafting - -	Gears - - -
Hangers - -	Bearings - -	Take Ups - -
Sprockels - -	Clutches - -	Chain Bolts - -
Floor Slands	Belt Tighteners	Rope Sheaves

Meeseco Short Center Drives

Meese & Gottfried Company

ENGINEERS AND MANUFACTURERS

CONVEYING, ELEVATING, SCREENING
AND MECHANICAL POWER TRANSMITTING
MACHINERY

SAN FRANCISCO 560 Market Street	SEATTLE 555 First Ave. So.	PORTLAND 67 Front Street	LOS ANGELES San Pedro & 3rd St.
------------------------------------	-------------------------------	-----------------------------	------------------------------------

When writing to Advertisers please mention this magazine.



Corner of Breakfast Room, House of Mr. C. C. Abdy, San Francisco

Paper, Drapes and Furniture

by

Taylor Galleries

Formerly F. A. Taylor Company

ARTISTIC INTERIORS

Special Furniture Drapes-Wall Paper

1818 Harrison Street

near 19th Street

OAKLAND, CALIFORNIA



CEMENT GUN

Will Make Your
Concrete Waterproof

**Cement Gun Con-
struction Company**
of California

701 Balboa Building,
San Francisco

For
DAMS
RESERVOIRS
TUNNELS
BULKHEADS
CANAL
LININGS
CEMENT
FLUMES
use the
Cement Gun
—
SPEED
ECONOMY
PERMANENCE

examination, but because the appointee has demonstrated some pre-eminent ability in his particular calling.

How many builders in the country could offhand qualify on even the simplest of technical questions? There are any number of first class, capable contractors and builders who couldn't read a blueprint to save their lives. They hire men to do that, but they have that something in them which no amount of book-learning or even experience can instill—that contractor's sixth sense that some men seem born with, and without which no one becomes a big, successful contractor. As evidence of this, how many engineers who have made great reputations in their profession, have succeeded as contractors? Yet they could pass the toughest technical examination with flying colors.

Advocates cite as an argument for licensing the builder, the fact of State control over doctors, lawyers, architects and engineers. We think the comparison is far-fetched. A thorough university training is indispensable for the practice of those professions, and we are not convinced, nor have we heard it advanced, that a college education is a *sine que non* for a builder. Doctors' and lawyers' operations are based on confidential personal relations, the very nature of which requires that only the selected few shall be permitted to practice. The control by

license of architects and engineers is comparatively new and has been adopted by eleven states thus far. We think it proper that the man upon whose design the safety of a structure depends, should demonstrate his capacity and knowledge for making the design before being permitted to hang out his shingle. We think the records will show there have been more building and structural failures through faulty design than faulty methods of construction. A strict license law for architects and engineers will do more to safeguard building than licensing the builder.

Contracting is more of a business than a profession. Certain elements in it re-



Residence of C. H. S. Littleton, 1350 So. El
Morino St., Pasadena, Calif.

BAY STATE COATING

The heaviest rains can't beat through a Bay State Coated wall. Weather won't affect it. Bay State Brick and Cement Coating waterproofs all houses of brick, cement or stucco. It imparts a beauty that is distinctive and lasting. Choose from white or a range of colors. We will gladly send you a sample. Write for booklet No. 43. It shows many homes made beautiful with Bay State Brick and Cement Coating.



WADSWORTH, HOWLAND & CO., Inc.

Paint and Varnish Makers
BOSTON, MASS.



James Hambly & Sons, 268 Market
St., San Francisco, Cal., and 447-449
E. Third Street, Los Angeles.

NATIONAL ROOFING COMPANY
J. F. ELLIS
PACIFIC ROOFING COMPANY
J. B. McKEON
C. G. WILLIAMS
A. K. GOODMUNDSON

Members of

Builders and Roofers Exchange
2140 San Pablo Avenue, OAKLAND
Lakeside 271



PLANT OF COAST TIRE AND RUBBER COMPANY, OAKLAND
 Designed by L. L. SMITH, C. E. FOUNDATION COMPANY, Builders

Michigan Maple Flooring laid in this building has stood the test for years, and is admitted to be the Acme of perfection.

A flooring for discriminating architects and builders.

“Wolverine Brand” Maple Flooring, a Michigan product, is superior in its manufacture.



STRABLE HARDWOOD COMPANY

Formerly

Strable Manufacturing Company

511-515 First Street

OAKLAND, CALIFORNIA

quire professional men, technical graduates, and so do certain elements in the manufacture of steel, but does any one contend that the steel manufacturer should be licensed? Contractors are manufacturers in a sense—in some instances, legal decisions have been rendered to that effect. They are assemblers of material to form a finished product. Skill and experience are necessary—absolutely essential—to do that assembling correctly, just as they are necessary to the successful iron-master. But more than skill and experience in the mere assembling are necessary for the successful builder or contractor. Like the iron-master, merchant or manufacturer, he must be a sound financier, a trained executive, an able administrative. Without these qualities all the technical knowledge in the world couldn't make him a successful builder. And examinations would fail to reveal them.

For these reasons we fail to see how the public would benefit or be protected by a license law for builders.

Licensing Contractors Not Feasible

Licensing the contractor under State law, a proposition which has been under discussion in Illinois, will not be pressed by the organized contractors before the present Legislature, says the American Contractor. The recent meeting of the Associated Building Contractors held in Chicago, showed very clearly a marked division of sentiment and the opposition to the proposition was strong enough to lay the matter on the table.

It is very doubtful if any improvement in the ethics or the responsibility of the contracting business can be brought about by State license laws. As Mr. F. E. Davidson, president of the Illinois Society of Architects, pointed out in his discussion before the convention, contracting is a business and there is a clear line of difference between this business and the professions for which license laws have been provided.

Improvement in the ethics and the character of the contracting business is a function of the contracting organizations; it is

perhaps the chief excuse for their existence and the contractor who earnestly desires to see the contracting business prosper and meet its responsibilities in a creditable way, can further that cause no more effectively than to join an organization and give it his best thought and effort.

State Builders' Exchange

The State Builders' Exchange was organized in Sacramento during the past month with the following officers: President, Mr. John D. McGillyray, San Francisco; vice-president, Mr. William Herman, San Jose; secretary, Mr. H. Dixon, Sacramento; board of directors, Messrs. E. A. Graff, Oakland, W. O. Crosby, Vallejo, F. M. Booth, Marysville, George Cardiff, Santa Cruz, Charles LeMasters, Fresno, and the president, vice-president and secretary.

NATIONAL WINDOW SHADE COMPANY, Inc.

Agents for
BRENLIN
The Long Wearing
Window Shade
Material

National Shades wear
twice as long as the
ordinary kind

Phone Franklin 552

244 EDDY STREET, SAN FRANCISCO, CAL.

**Clocks Were Never Needed 'Til Time
Acquired a Value** *☞*



**"ISH-KA-
BIBBLE"**



**Electric Clock and Program Bell Systems,
Automatic Control of Time Keeping Devices
for Schools, Hospitals, Public and Private
Buildings, Banks Etc., Automatic Calling
Systems**

Please Note

Right here on the Pacific Coast we are manufacturing and distributing Electric Clocks, designed and engineered by J. J. Estabrook, a man who knows how, with twenty-five years' experience—nine years on the Pacific Coast.

Plans, specifications and any engineering information, estimates, etc., cheerfully furnished to architects, engineers or any one interested in this special line of work.

SERVICE

is our motto

PACIFIC ELECTRIC CLOCK CO.

J. J. ESTABROOK

516 Wells Fargo Building

San Francisco, Calif. Telephone Sutter 809



A LIQUID FLOOR COVERING

for Outside and Inside Floors
of Wood, Cement or Concrete

STANDARD VARNISH WORKS

GENERAL OFFICE: 90 WEST STREET, NEW YORK

San Francisco Offices and Warehouse, 55 Stevenson Street

THE LISTING BUREAU, heretofore operated in the interest of the majority of the PLANING MILLS of San Francisco; with a view of standardizing the business of submitting "Full Mill Bids," to the end that competitive bids submitted by the different concerns, on the various contracts, will be based on a common understanding of the items included in, and covered by, such bids, having, after a fair and thorough trial proven its efficacy along the lines indicated above; it has been decided to enlarge the scope of the Bureau with a plan of co-operating with Architects, Owners and Contractors.

It is proposed to furnish "Bills of Items" on Mill work for any structure, according to plans or specifications, to those who may require them; either owners who build for themselves, or architects who desire a check on figures submitted them; or contractors who are estimating; or to planing mills—whether affiliated with the Bureau—or independents; at a reasonable charge sufficient to defray the expense of the operation of the Bureau.

And it has been further decided that not only plans of buildings in the city of San Francisco will be listed for quantities, but prospective buildings which are erected outside of the city will be surveyed so they can be readily priced by the buyer or bidder.

The Bureau guarantees the quantities on the list furnished as being sufficient to fulfill the contract and carries on hand a "guarantee fund" to reimburse clients for any errors of its surveyors, should such occur.

Correspondence solicited and investigation of operation and responsibility courted.

LISTING BUREAU

Room 702, Williams Building, 693 Mission Street,
San Francisco. Phone, Sutter 3340.

"A reliable feed water regulator is both an insurance and an element of economy." — *Joseph Harrington*

The "S-C" Feed Water Regulator

By feeding always in proportion to load and fire conditions, The "S-C" Regulator insures the utmost in safe and economic steaming.

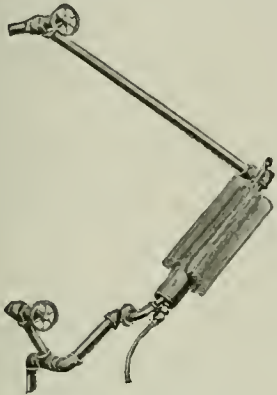

"S-C" Generator—Actuating Element of Regulator

"S-C" Equipment is in use today by the leaders in every line of industry thruout the world.

The apparatus of 320% earning capacity. Saves a million dollars worth of fuel every year.

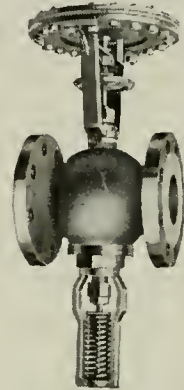

"S-C" Regulator Valve

The "S-C" Pump Governor

Meets every Pump Governor demand.

The only real governor for a turbine driven pump.

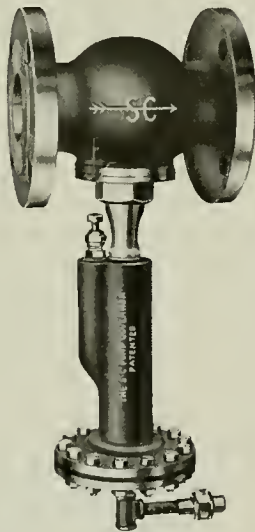

No Levers, Weights or Dashpots.

Absolutely positive in action under all conditions.

A Post Card will bring complete catalog.

W. E. MUSHET CO

502 Mission Street

SAN FRANCISCO



Sand Company Improves Its Equipment

Architects and contractors throughout the Pacific Coast will be interested in the announcement of the Del Monte Properties Company of greatly improved facilities for preparing and loading Del Monte and Fan Shell beach white silica sands.

In addition to equipment for quick loading direct from pits to cars, the company has installed at Lake Majella a complete plant of the same type as the most modern and up-to-date plants used in the silica glass sand districts of Pennsylvania, West Virginia and other states, for washing and drying sand. The process through the plant involves washing the sand in fresh water and drying it by steam, and eliminates the vegetable and other impurities, resulting in a thoroughly clean, bone dry product.

These washed and dried sands will be particularly interesting to architects, contractors and the building trades in general because of their economical value in mortars, plasters, stucco, artificial stone, etc., where an absolutely clean, white sand is desirable.

The company states that it is prepared to ship promptly and in any quantities the untreated sands loaded direct from pits to cars, same as heretofore, or the same sands washed and dried. Bulk shipment direct from the pits will be made unless particularly requested, otherwise, in gondola cars. The washed and dried sand will be shipped in bulk or sacked, as may be preferred. For bulk shipment, paper lined box cars will be used, unless otherwise ordered.

White Brothers Take Agency for Compo-Board

White Brothers, pioneer San Francisco hardware dealers, have taken the agency for "Compo-Board," a wood board entirely different from the wood-pulp boards of which the market provides so many examples.

"Compo-Board" has a solid redwood core and is in reality wood. It is suitable for a thousand and one purposes besides that of a wall board. It can be sawn, cut, nailed and handled in every way the same as a board of wood; it is useful for making walls, boxes, drawer bottoms, mirror-backs, furniture sides, screens, store window backgrounds, blackboards, medicine closets, filing case divisions, store decorations, kitchen cabinets, showcases, etc. "Compo-Board" comes in sheets 4 feet wide by 6 to 16 feet long.

White Brothers have long been considering this move, and inasmuch as the "Compo-Board" dovetails very well with their Wybro Panels and other materials, they feel that it is a logical addition to their business.

New Directory and Market Data Book.

Crain's Market Data Book and Directory of Class, Trade and Technical Papers, now on the press, promises to be of unusual interest to advertisers generally and users of trade and technical papers in particular. It not only lists all of the business publications of the United States and Canada, giving circulations, rates, type page sizes, closing dates, etc., but supplies a market analysis of each trade, profession and industry. Thus the reader is given the basic facts of each line in which he may be interested, including its buying power, buying methods, character of requirements, etc. The volume, which is bound in cloth and contains nearly 500 pages, is published by G. D. Crain, Jr., 417 S. Dearborn street, Chicago. The price is \$5. Orders in advance of publication are being accepted at the rate of \$3.75.

Stantly Works in Los Angeles

Mr. L. M. Knouse who was formerly in charge of the San Francisco office of the John Rountree Company, and who was recently appointed district sales manager of the Stantly Works at Los Angeles, is now permanently settled in his Southern California offices. They are in the Washington building, which seems to be a favorite office center for San Francisco firms, others who have offices there being Messrs. MacDonald and Kahn and the Pacific Manufacturing Company. Mr. Knouse will be glad to give his services to architects and others in the Los Angeles territory, where Stantly ball-bearing drills and garage hardware are specified.

Twenty Per Cent Cut

The H. Mueller Manufacturing Company, brass plumbing goods, of Decatur, Ill., has announced that it has reduced the price of its goods an average of 20 per cent. Wages of its 900 employees in Decatur have been reduced an average of 10 per cent. President Mueller declared that a survey of conditions convinced the company that the public will build when materials and labor come down, and the price reduction is the company's contribution to a revival in building activities.

State Highway Work to Proceed

The California State Highway Commission is again advertising for bids for new highway work long deferred on account of high prices and lack of funds. The \$40,000,000 bond issue voted last fall will enable the commission to get started but will not be sufficient to carry out its pretentious plans. A special tax on gasoline is likely to be authorized by the present legislature as a feasible method of raising more income.



The
ST. FRANCIS
One of the world's great hotels
Facing Union Square
SAN FRANCISCO CALIFORNIA

EXPRESSES MOST PLEASANTLY THE HOSPITALITY AND ANIMATION THAT ARE CHARACTERISTIC OF SAN FRANCISCO

Thos. J. Coleman
Manager

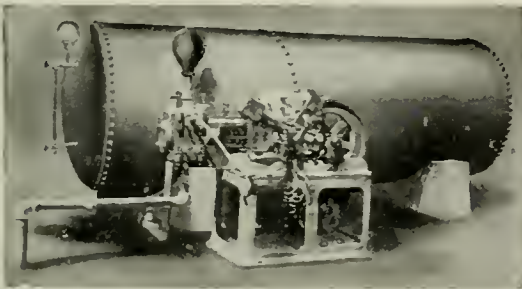

Kewanee Water System

Maintain your own Plant.
Small Operating Expense.
A Perfect Water Supply to
Country Homes, Hotels
and Parks.

Simonds Machinery Co.

117- 121 Montgomery Street
SAN FRANCISCO
Phone Kearny 1457



HEARD BUILDING, PHOENIX, ARIZONA
 Llewellyn A. Parker, Architect and Engineer, Los Angeles

Arizona's Finest Office Building is faced with
Enamel Brick and Terra Cotta Trim

Manufactured by

Los Angeles Pressed Brick Co.

FROST BUILDING, LOS ANGELES

UNITED MATERIALS COMPANY

SHARON BUILDING, SAN FRANCISCO

Distributors for Northern California

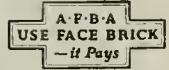

*Old Spanish Gateway,
Amsterdam*

THROUGH the genius of the architect and the skill of the brick-maker, brick has been adapted to all the changing structural and artistic requirements in building, from the earliest recorded history to the present day.

True to the tradition of the craft, the makers of face brick in America have kept abreast of the architect's demands. New color tones and new textures have, in the past generation, been

produced to such an extent that the architect has now at his command practically the whole gamut of color. In numerous instances new brick have been created to meet the peculiar conditions of a particular design.

Any member of this association is at all times ready to discuss the architect's face brick problems with him; and to co-operate with him to the fullest extent.

AMERICAN FACE BRICK ASSOCIATION

1159 WESTMINSTER BUILDING · CHICAGO, ILLINOIS

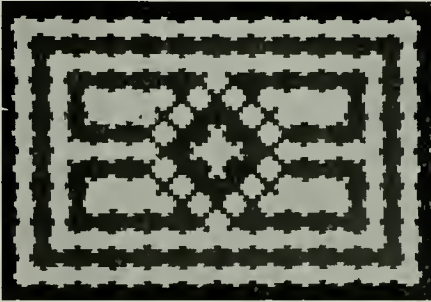

INTERLOCKING RUBBER TILING

material that is sure to give satisfaction. **Twenty tons installed in the Standard Oil Building, San Francisco.**
Stock on hand for immediate delivery.

New York Belting and Packing Co.

NEW YORK

San Francisco Branch 519 MISSION ST. Phone Douglas 1837

Small booklet of designs mailed on request.

The Elevator Floor

whether in Office Building, Hotel or Department Store, is subjected to a great deal of wear and tear.

—SPECIFY—

INTERLOCKING RUBBER TILING

and you've provided your client's building with a Durable, Economical, Practical,

Twenty tons



TiteSete Float Valve

For High and Low Pressures

IN SIZES UP TO 4 INCHES
Larger Sizes on special order

Remains Wide Open
until desired Water Level
is reached then Closes
POSITIVELY without
Water Hammer

Simple and Durable
Positive and Reliable



Self-Cleaning,
Non-Clogging
By-Pass

NATIONAL VALVE COMPANY

Phone Douglas 5093

23-25 MINNA ST., SAN FRANCISCO

The Heart of the Kitchen

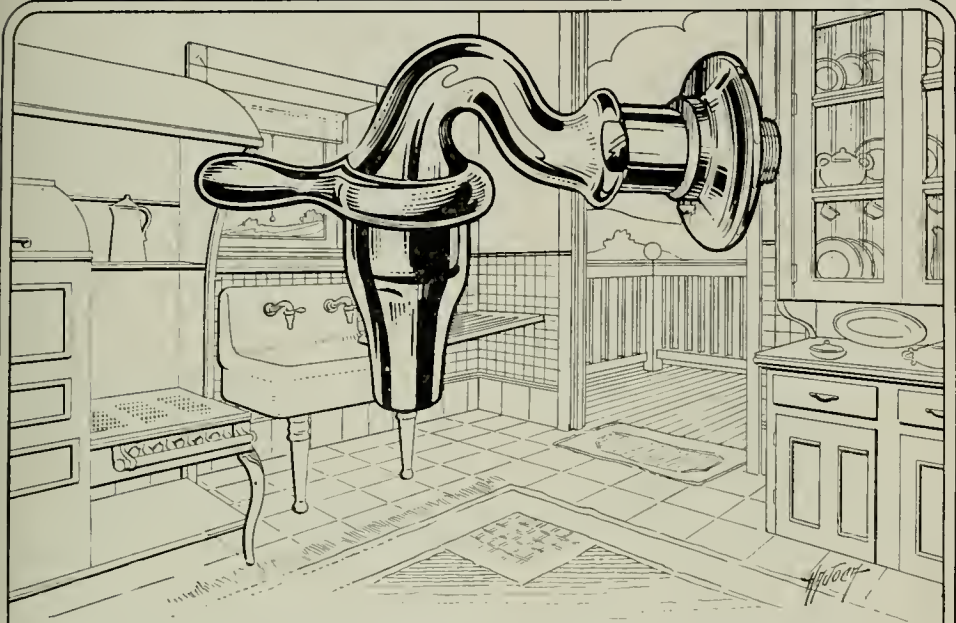

ONE of the most prominent Architect firms in San Francisco, and well known throughout the country, without solicitation on our part, wrote us as follows:

“We not only specify but insist on the plumber furnishing HAJOCA ‘Quick’ Faucets for all sinks in buildings constructed by us.

We consider everything from the rapid flowing stream to the simplicity of re-washing a delight to the user.”

HAJOCA “Quick” Faucets are used not only on kitchen sinks, but shop sinks, laundry trays and factory wash sinks.

Many Architects, like the firm above quoted are standardizing their specifications on HAJOCA “Quick” Faucets.

HAINES, JONES & CADBURY Co.

MAKERS OF PLUMBING SUPPLIES

851-9 FOLSOM STREET, SAN FRANCISCO

PHILADELPHIA-NEW YORK-RICHMOND, VA.-SAVANNAH



IRON AND STEEL PRODUCTS

WAREHOUSE AND
MILL SHIPMENTS

STEEL BARS

for

CONCRETE
REINFORCING
FURNISHED AND
INSTALLED

EDW. L. SOULE' CO.
SAN FRANCISCO



SUTTER
2821



RIALTO
BUILDING

SERVICE

TESTING
INSPECTION
CONSULTATION
PRODUCTION

Structural and Engineering
Materials



Robert W. Hunt & Co.
Engineers

Chemical and Physical
Testing Laboratories

New York Chicago Pittsburgh
St. Louis San Francisco Mexico City
London Montreal

A PROPRIETOR BOUND HIMSELF

to maintain fire insurance for the amount paid by him to the contractor as the construction of the building progressed. The building was burned while in course of construction and the company denied liability on the ground that the proprietor had no insurable interest. The court held that the proprietor had an insurable interest in the building equal to the amount paid to the contractor.

DIXWELL DAVENPORT
Manager Pacific Coast Department

**BANKERS & SHIPPERS
INSURANCE COMPANY**
INSURANCE EXCHANGE BLDG.
SAN FRANCISCO
Telephone Kearny 3561

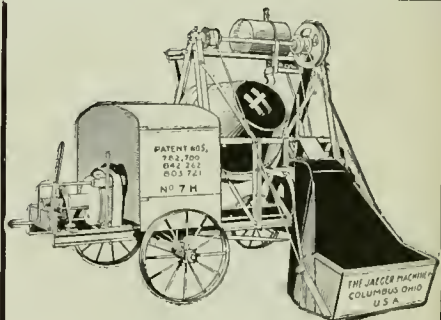

NOT ONLY MIXERS

but a full line of nationally-known equipment, as well.

We have prepared for a brisk building season.

"Get it from BACON"

Edward R. Bacon Company

51 Minna St., San Francisco

165 E. Jefferson St.
Los Angeles

Present Cost of Building Materials* With Labor Wage Scale, Bonds, Etc.

THESE quotations are based on reliable information furnished by San Francisco material houses. Date of quotations, February 15, 1921.

All prices f. o. b. cars San Francisco or Oakland. For country work add freight and cartage to prices given.

American Institute of Architects' Fees

New work—6 per cent minimum basis.

Alterations—7 to 10 per cent as a minimum basis.

High class residence work—10 per cent as a minimum.

Bond— $1\frac{1}{2}\%$ amount of contract.

Brickwork—

Common, \$40.00 per 1000 laid.

Face, \$90.00 per 1000 laid.

Common, f. o. b. cars, \$18.00 plus cartage.

Face, f. o. b. cars, \$60.00 per 1000, carload lots.

HOLLOW TILE FIREPROOFING

12x12x3 in., 10 $\frac{1}{4}$ c. per square foot.

12x12x4 in., 11 $\frac{3}{4}$ c. per square foot.

12x12x6 in., 16 $\frac{1}{4}$ c. per square foot.

Hod carriers, \$8.00 per day.

Bricklayers, \$10.00 per day.

Line—\$3.25 per bbl.; carload, \$2.75 per bbl.

Composition Floors—30c. per sq. ft.

Concrete Work (material at San Francisco bunkers)—

No. 3 rock.....\$2.50 per yd.

No. 4 rock..... 2.75 per yd.

Niles pea gravel..... 3.25 per yd.

Niles gravel..... 2.50 per yd.

Niles top gravel..... 3.00 per yd.

City gravel..... 2.50 per yd.

River sand..... 1.65 per yd.

Bank sand..... 1.00 per yd.

SAND

Del Monte, \$1.25 to \$1.50 per ton.

Fan Shell Beach, \$2.50 to \$3.00 per ton.

Car lots, f. o. b. Lake Majella.

Cement (f. o. b. cars).....\$3.69 per bbl.

Rebate for sacks, 15c each.

Atlas "White".....\$12.60 per bbl.

Medusa cement.....\$12.60 per bbl.

Forms.....\$60.00 per M

Wage—

Laborers.....\$6.00 per day

Concrete workers..... 7.50 per day

Cement finishers..... 9.00 per day

Dampproofing—

Two-coat work, 25c per yard.

Membrane waterproofing—4 layers of P.

B. saturated felt, \$6.00 per square.

Hot coating work, \$2.00 per square.

WAGE—Roofers, \$9.00 per day.

Electric Wiring—\$8.00 to \$12.00 per outlet (including switches).

WAGE—Electricians, \$9.00 per day. For conduit work, knob and tube average \$4.50 outlet.

Elevators—

Prices vary according to capacity speed and type. Consult elevator companies.

Excavation—

\$2.00 per yard.

Teams, \$12.00 per day.

Trucks, \$30.00 to \$40.00 per day.

Above figures are an average without water. Steam shovel work in large quantities, less; hard material, such as rock, will run considerably more.

Fire Escapes—

Ten-foot balcony, with stairs, \$100.00 per balcony.

Glass—(Consult with manufacturers.)

21 ounce, 20c per square foot.

Plate, \$1.75 per square foot.

Art, \$1.00 up per square foot.

Wire (for skylights), 45c. per square foot.

Obscure glass, 30c. per square foot.

Note.—Add extra for setting.

WAGE—Glaziers, \$9.00 per day.

Heating—

Average, \$2.00 per sq. ft. of radiation, according to conditions.

WAGE—Steamfitters, \$10.00 per day.

Iron—

Cost of ornamental iron, cast iron, etc., depends on design.

Lumber—

Common (at building), \$36.00 per 1000 (average).

Common O. P. (select), \$65.00 per 1000 (average).

Flooring—

1x3 No. 1.....\$80.00 per 1000

1x3 No. 2..... 70.00 per 1000

1x4 No. 1..... 80.00 per 1000

1x4 No. 2..... 70.00 per 1000

1x4 No. 3..... 60.00 per 1000

1x6 No. 1..... 80.00 per 1000

1x6 No. 2..... 70.00 per 1000

1 $\frac{1}{4}$ x4 and 6 No. 1..... 84.00 per 1000

1 $\frac{1}{4}$ x4 and 6 No. 2..... 75.00 per 1000

Slash grain, 1x4 No. 2..... 65.00 per 1000

Slash grain, 1x4 No. 3..... 55.00 per 1000

No. 1 common run to

T. & G..... 45.00 per 1000

Lath..... 5.00 per-1000

Shingles—

Redwood, No. 1.....\$1.00 per bdle.

No. 2..... .90 per bdle.

Red Cedar..... 1.10 per bdle.

(Add cartage to above)

Hardwood Floors—

Maple floor (laid and finished), 30c per foot.

Factory grade floors (laid and finished), 23c per foot.

Oak (quartered, finished), 40c per foot.

$\frac{7}{8}$ Oak (clear), 30c per foot (plain).

$\frac{5}{8}$ Oak (select), 28c per foot (plain).

$\frac{7}{8}$ Oak, quartered, sawed, clear, 35c.

WAGE—Floor layers, \$10.00 per day.

Hardwood Floors (not laid)— Per M ft.

5/16x2" sq. edge Clear quartered oak.....\$220.00

Select quartered oak..... 162.50

Clear plain oak..... 147.50

Select plain oak..... 127.50

THE ARCHITECT AND ENGINEER

Hardwood Floors (not laid)—Continued

	Per M ft.
13/16x2 1/4" face Clear quartered oak.....	\$292.50
Select quartered oak.....	200.00
Clear plain oak.....	200.00
Select plain oak.....	180.00
Clear maple.....	160.00
Clear maple—white.....	250.00
13/16x3 1/4" face Clear maple.....	160.00
1 1/4x2 1/4" face Clear maple.....	160.00
3/8x2" face Clear quartered oak.....	215.00
Select quartered oak.....	160.00
Clear plain oak.....	147.50
Select plain oak.....	127.50
Clear maple.....	122.50

Millwork—

O. P., \$120 per 1000. R. W., \$140 per 1000	
Double hung box frame windows (average) with trim.....	\$7.50 each
Doors, includ. trim (single panel).....	\$11.00 each
Doors, including trim (five panel).....	\$9.00 each
Screen doors.....	3.00 each
Window screens.....	2.25 each
Medicine cases.....	4.00 each
Cases for kitchen pantries seven feet high, per lineal foot.....	7.50 each
Dining room cases same price, if not too elaborate... ..	7.50 each
Flag poles, per foot.....	1.00

Labor—Rough carpentry, warehouse heavy framing, \$13.00 per 1000.

For smaller work, average, \$21.00 to \$28.00 per 1000.

WAGE—Laborers, \$6.50 per day.
Carpenters, \$9.00 per day.

Marble—(Not set) add 60c up per ft. for setting

Columbia.....	\$2.05 sq. ft.
Alaska.....	2.05 sq. ft.
San Saba.....	3.65 sq. ft.
Tennessee.....	2.50 sq. ft.
Verde Antique.....	4.55 sq. ft.

Painting—

Two-coat work, 42c. per yard.
Three-coat work, 55c per yard.
Whitewashing, 5c per yard.
Cold water paint, 9c per yard.
Turpentine, \$1.07 per gal. in cases and 92c per gal in tanks.
Raw Linseed oil, 94c per gal in barrels.
Boiled Linseed oil, 96c per gal in bbls.
Pioneer white and red lead, 11 3/4c lb. in one ton purchases; 12 1/2c lb. for less than 500 lbs.
WAGE—Painters, \$8.50 per day.

NOTE—Accessibility and conditions cause wide variance of costs.

Patent Chimneys—

6-inch.....	\$1.50 lineal foot
8-inch.....	1.75 lineal foot
10-inch.....	2.25 lineal foot
12-inch.....	3.00 lineal foot

Pipe Casings—\$8.00 each.

Plastering—

Interior, on wood lath, 75c per yard.
Interior, on metal lath, \$1.40 per yard.
Exterior, on brick or concrete, \$1.35 per yard.
Portland White, \$1.75 to \$2.00.
Interior on brick or terra cotta, 60c to 70c per yard.

Exterior, on metal lath, \$2.00 to \$2.50 per yard.
Wood lath, \$6.50 at yard per 1000.
Metal studding, \$1.25 to \$1.50 per yard.

Metal studding, with lath and plaster, \$2.00 per yard.

Galv. (metal lath), 38c. and up per yard, according to gauge.

Lime, f. o. b. warehouse, \$3.25 per bbl. Hardwall plaster, \$22.00 per ton, f. o. b. warehouse. (Rebate on sacks, 15c.)

WAGE—Hod carriers \$9.00 per day.

Plasterers, \$11.00 per day.

Plumbing—

From \$70.00 per fixture up, according to grade, quantity and runs.

WAGE—Plumbers, \$10.00 per day.

Reinforcing Steel—

Base price for less than car load lots, \$4.25 per 100 lbs.

Carload lots, \$4.00 per 100 lbs., f. o. b. San Francisco. (Mill delivery.)

Roofing—

Five-ply tar and gravel, \$7.00 per square for 30 squares or over.

Less than 30 squares, \$8.00 per square.

Tile, \$35.00 to \$50.00 per square.

Redwood shingle, \$10.00 per sq. in place.

Cedar shingle, \$10.00 per square in place.

Reinforced Pacbo roofing, \$8.25 per square. WAGE—Roofers, \$9.00 per day.

Rough Hardware—

Nails, per keg, \$7.00 base and very scarce.

Deafening felt, \$170.00 per ton.

Building paper, P. & B.,

1 ply, \$5.10 per 1000 ft. roll.

2 ply, \$7.50 per 1000 ft. roll.

3 ply, \$10.00 per 1000 ft. roll.

Sash cord,

(Sampson spot), \$3.00 per hank 100 ft.

Common, \$1.75 per hank 100 feet.

Sash weights, cast iron, \$70.00 per ton.

Sheet Metal—

Windows—Metal, \$2.00 a square foot.

Skylights—

Copper, \$1.25 a square foot (not glazed).

Galvanized iron, 40c a square foot (not glazed).

WAGE—Sheet metal workers, \$10.00 per day.

Store Fronts—

Kawneer copper bars for store fronts.

Corner, center and around sides, will average \$1.35 per lin. foot.

Zouri bar, \$1.25 per lin. foot.

Zouri Underwriters' Specification sash, \$1.60 per lin. foot.

Structural Steel—\$140.00 per ton (erected).

This quotation is an average for comparatively small quantities.

Light truss work higher; plain beam and column work in large quantities, less.

Steel Sash—

Fenestra, from S. F. stock, 45c per sq. ft.

Fenestra, Plant shipment, 40 1/2c per sq. ft. (Includes mullions and hardware.)

Trus-con, from San Francisco stock, 40c to 45c per sq. ft.

Trus-con, plant shipment, 35c to 42c per sq. ft.

U. S. Metal Products Co., 40c per sq. ft. in San Francisco.

Tile—

White glazed, 80c. per foot.

White floor, 80c. per foot.

Colored floor tile, \$1.00 per foot.

Promenade tile, \$1.00 per sq. foot, laid.

WAGE—Tilersetters, \$9.00 per day

ARMCO INGOT IRON



Detail of Carnegie Library, San Francisco, with Armco Ingot Iron window grill.

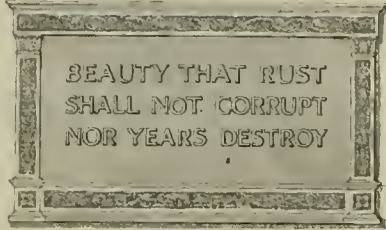

WHEN permanence and beauty are desired ARMCO Ingot Iron is used. No other commercial iron is so uniformly pure and rust-resisting.

All the sheet metal and iron grills on the windows of the beautiful Carnegie Library at San Francisco are made of ARMCO Ingot Iron—a fitting tribute to its enduring qualities.

Just as its purity and rust-resisting qualities made it the preferred metal for fabricating these beautiful grills, these same qualities make it the preferred metal for fabricating culverts, flumes, siphons, tanks, road signs and other formed products which must give long years of service.



Carnegie Library San Francisco; all sheet metal and iron grills on windows are of Armco Ingot Iron. Geo. W. Kelham, Architect.



The trade-mark ARMCO carries the assurance that products bearing that mark are manufactured by the American Rolling Mill Company with the skill, intelligence, and fidelity associated with its products, and hence can be depended upon to possess in the highest degree the merit claimed for them. The trade-mark ARMCO is registered in the U. S. Patent Office.

—for lasting satisfaction
specify

ARMCO

Ingot Iron

THE AMERICAN ROLLING MILL COMPANY
Middletown, Ohio

Licensed Manufacturers under Patents granted to the International Metal Products Company

Pacific Coast Sales Office—Tenth and Bryant Streets, San Francisco; other Branch Offices in New York, Chicago, Pittsburgh, Cleveland, Detroit, St. Louis, Cincinnati, Atlanta, Washington, D. C., and Buffalo.

An Ample Stock of Armco Iron is carried at San Francisco Warehouse.



Were You Ever in Brown's Fix?

BROWN was a moderately thriving architect and engineer, and it meant a great deal to him to have a shy at the big Hatfield & Cummins project.

While the development work he had handled stood very much to his credit, still he had never been connected with any construction of sufficient importance to bring his name into real prominence.

Naturally there was a great commotion when the phone rang and Hatfield's voice came over the wire:

"Mr. Brown, we have to go ahead on the extension of our new installation at once. Bring over a contract form by noon, guaranteeing your telephone estimate of November 8th and we will sign with you."

Brown clapped down the receiver. He was a made man!

The Hatfield & Cummins patronage meant connections and prestige that would convert him into a formidable competitor for all sorts of big propositions.

But in five minutes he had lost ten years of his optimism. The estimate was not to be found. He remembered perfectly having carefully put it away where he could readily find it — although the thought of having a swing at the big job had never really grazed him.

It was too late to refigure the estimate — it must be found. In a mad scramble, Brown and his office helpers went pawing over everything in the office — but no result. Brown hasn't found that

estimate yet although he gave up looking for it long ago.

His concern was not converted into prominence overnight. In the absence of an efficient filing system they had lost out in the big opportunity of years.

But Brown did not have to stub his toe twice to find out the trouble. He came into H. S. Crocker Company and told his story.

"Gentlemen," he said, "what can you do for me that will prevent a thing of that kind ever happening in my business again?"

He was shown the possibilities of the Globe-Wernicke Filing Cabinet for his particular office and requirements. He learned how he could have saved a large order for his business, and how in the future he would always be able to put his finger on any piece of correspondence or office data he chose no matter when it might be needed.

Needless to say, Brown's office has been reorganized for future protection and efficiency.

H. S. CROCKER CO., INC.

565-571 Market Street, San Francisco

Los Angeles

1444 Broadway, Oakland

Sacramento

**INCREASES PROFITS
FURNITURE SAVING**

U-TURN-IT

**SAVES MUCH SPACE
SELF VENTILATION**

Converts a 1-Room into A 4-Room Apartment

The Device is less than seven feet in diameter, seven feet six inches high, built of steel frame, and revolves on ball bearing floor ring; weighs, installed, 1500 pounds. Shipped f. o. b. Buffalo, N. Y., price \$600. 10% discount to original users.



Combined View of Library and Kitchen.

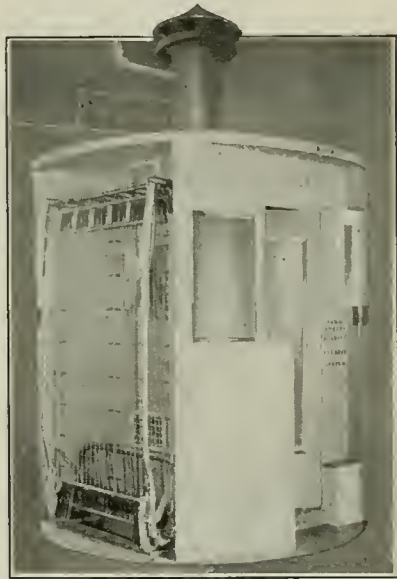

Bed and Dresser with Wardrobe.

Installed in new or old buildings, converts a one room into a four room apartment, containing conveniences of combination dresser, wardrobe and interior clothes closet; bedroom standard recess balanced lift bed, next to self ventilated ducts from the outer air when bed is in or out of use; library with writing desk, book cabinet and storage compartments; kitchen with complete plumbing, sink, hot and cold water, air tight revolving joints, designed to revolve with the U-Turn-It (approved by the Bureau of Plumbing Laws of the City of Buffalo, N. Y.) ice box and drain to sink, ironing board, china and kitchen utensil compartments; electrical, gas or oil hot plate stove, ventilated over head, and also garbage compartment with sanitary lining throughout.

Different types are made with two beds opposite for use in two or more rooms. Also types with kitchen omitted.

AGENTS WANTED IN PRINCIPAL COAST CITIES.

U-Turn-It Housekeeping System, Inc.

1202-1204 Claus Spreckels Building

SAN FRANCISCO, CALIFORNIA

ZOURI SAFETY SASH BARS



Accepted by the Insurance Underwriters for Safety Setting of Plate Glass used in Store Front Construction.
COBBLEDICK-KIBBE GLASS CO.
 175 JESSIE ST. WASHINGTON AT THIRD ST.
 SAN FRANCISCO, CAL. OAKLAND, CAL.

POWER CONSTRUCTION CO.

INCORPORATED

CONTRACTING ENGINEERS

Preliminary Estimates Given in All Types
of Buildings, Towers and Bridges

SHARON BUILDING, SAN FRANCISCO
Phone Sutter 5478

CHAS. STOCKHOLM & SONS

GENERAL CONTRACTORS

849 MONADNOCK BUILDING Phone DOUGLAS 4657 SAN FRANCISCO

John Ringius Company, Inc.

MANUFACTURERS OF

Multivane Volume Fans and Steel Plate Blowers made to order,
any size, for Heating and Ventilating Plants in Theatres,
Schools, Public Buildings, Etc.

Sheet Metal Products

Fans and Blowers

330 Ritch Street

SAN FRANCISCO

Phone Garfield 1108

JOHN M. BARTLETT

GENERAL CONTRACTOR

Office
357 - 12th ST., OAKLAND

Phone Lakeside 6750
Res. Phone Berkeley 6884W

E. T. LEITER & SONS

BUILDING CONSTRUCTION

412 CALL-POST BUILDING Phone SUTTER 1980 SAN FRANCISCO

Shop and Compare—that's the only true test
of values.

Furnishings for the home of distinctive style are
featured in this shop at prices that will bear the
strictest comparison.

Furniture Draperies Floor Coverings Interior Decorations

John Breuner Co.
of San Francisco

281 GEARY STREET

SAMSON SPOT SASH CORD



SPOT IT BY THE SPOTS
Made of extra quality cotton yarn, firmly braided and smoothly finished, Carefully inspected and
guaranteed free from all imperfections of braid and finish. → Can be distinguished at a glance
by our trade-mark, the Colored Spots. Send for catalogue and samples.

Pacific Coast Agent, JOHN T. ROWNTREE, Inc., San Francisco and Los Angeles, Cal.

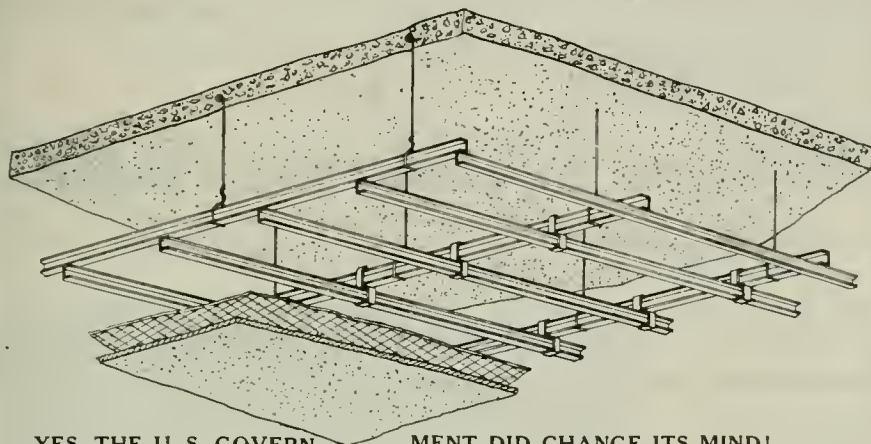

YES, THE U. S. GOVERNMENT DID CHANGE ITS MIND!

The specifications on the U. S. Government Building at Portland, Oregon, called for the tying together of the carrying bar and lathing bar with wire.

We submitted our system, and after an explanation of the S. S. System for fastening bars, the engineers and government officials were convinced that here, at last, is the perfect and economical system, and these reasons added weight in deciding.

It is a positive tie, no slipping or shearing.

It is strong, Smith Emery test to 353 lbs. before failing.

It is fast, can be applied on the bench or on the scaffold.

Made for 1 inch carrying bar and 3/4 inch lathing bar and 3/4 inch carrying bar and 3/4 inch lathing bar. Can be used for wall furring as well as for ceiling work.

THE STEEL STUDDING COMPANY

Also Manufacturers of

THE PRONG CHANNEL FOR SOLID AND HOLLOW PARTITIONS

Agents Wanted Everywhere

1216 Folsom Street, San Francisco

Look for this
Trademark

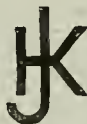

And if it's there don't worry
any more about your
Valves and Fittings

*Specify and
insist upon
having*

**The Kelly & Jones Co.
Valves and Fittings**

**Byers Genuine
Wrought Iron Pipe**

Republic Steel Pipe

Complete Line of Plumbing Supplies
Large Stocks for Prompt Delivery
Catalogue on request

**California Steam &
Plumbing Supply Co.**

671-679 Fifth Street, Corner Bluxome
SAN FRANCISCO, CALIFORNIA



**FOR MODERN
STORE FRONTS**

Plummer's Disappearing Awnings

Are constructed with no outside attachments below awning recess. All mechanical parts entirely concealed. Send for Architects' Sheet showing specifications for recess construction, etc.

W. A. PLUMMER MFG. CO., 35-37 Front Street, San Francisco

JOHN TRAYNOR

CHARLES HARCOURT

OCEAN SHORE IRON WORKS

Manufacturers of Oil Tanks, Water Tanks, Pressure Tanks, Air Receivers, Feed Water Heaters, Breechings, Smoke Stacks, Water Pipe, Boilers, Retorts, Digestors, Pneumatic Pressure Tanks, Riveted or Oxy-Acetylene Welded Tanks, and dealers in Boilers, Tanks, Pumps, Engines, Machinery, Steel Plates, Shapes

Special Attention Given to Government and Export Orders

OCEAN SHORE IRON WORKS

Office and Works: 550-558 EIGHTH STREET, SAN FRANCISCO, CAL.

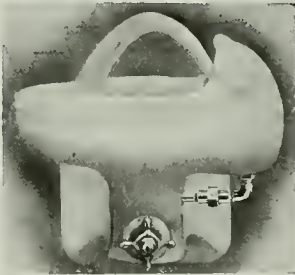

Model No. 7A.

NO GERMS HERE

HAWS IMPROVED SANITARY DRINKING FAUCET eliminates all possibility of contracting disease from dirty bulbs or un-sanitary bowls. Provided with an overhead cowl, the drinker's lips never touch the source of supply. A slanting stream throws the water from right to left and away from the bubbler, instead of straight up to fall back over the fountain head. Recommended for Schools and Public Playgrounds. A type used extensively by the U. S. Government. Manufactured by

Haws Sanitary Drinking Faucet Co., Inc.
1808 Harmon Street, Berkeley Phone Piedmont 3742

GLADDING, McBEAN & CO.

MANUFACTURERS CLAY PRODUCTS
CROCKER BUILDING, SAN FRANCISCO
WORKS, LINCOLN, CAL.

AMBASSADOR HOTEL, Los Angeles

ARCHITECT MYRON HUNT

SHOWING

WILSON Folding Partition

in DON LEE CONCESSION — Cadillac Cars

All Folding Partitions in Ambassador Hotel furnished and installed by THE J. G. WILSON CORPORATION.



Note pair of doors and return end of partition.

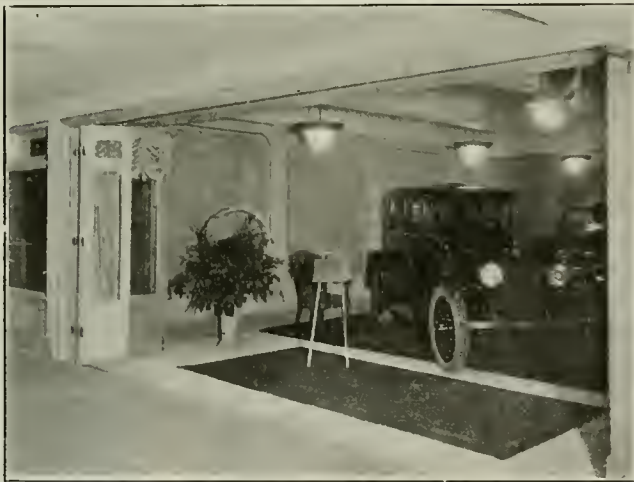

Showing partition folded back giving an entire clear opening.

Send for particulars to

The J. G. Wilson Corporation

MANUFACTURERS OF

Diffuselite Blinds and Awnings, Rolling Partitions, Rolling Steel Doors, Folding Partitions, School Wardrobes, Folding Casements

PACIFIC COAST OFFICE AND EXHIBIT:

600 METROPOLITAN BUILDING. Phones 60871; Bdy. 502, LOS ANGELES, CALIF.

Waterhouse-Wilcox Co., San Francisco Theo. F. Snyder, San Diego F. W. Farrington & Co., Portland
 F. W. Farrington & Co., Seattle Hawley-Richardson-Williams Co., Salt Lake City Walter Dubree, Phoenix

THE TORMEY CO.

General
Painters

Phone Franklin
5-5-9-8

1042 Larkin St., San Francisco, Cal.

Alvaline, Cementoline
and other
Jones-Duncan Products

MAGNER BROTHERS
PAINT MAKERS

Telephone: Market 113
414-424 Ninth St. San Francisco

HEATING-PLUMBING

COMPLETE PLUMBING AND
HEATING SYSTEMS INSTALLED
IN ALL CLASSES OF BUILDINGS
ALSO POWER PLANTS

GILLEY-SCHMID CO., Inc.

198 OTIS STREET, SAN FRANCISCO.
Tel. MARKET 965

"BLAZING" THE TRAIL
We've been doing it for many years—giving the Sportsman Better Value for Quality than he ever before received. "Value at a Fair Price" in everything for the Sportsman.

The
Ellery Arms
Company

583-85 MARKET ST.
SAN FRANCISCO, CAL.

SEND FOR CATALOG *The Sign of Quality*

Phone Douglas 3224

Hunter & Hudson
ENGINEERS

Designers of Heating, Ventilating
and Wiring Systems. Mechanical
and Electrical Equipment of
Buildings.

703 Rialto Bldg., San Francisco, Cal.

BEAVER BLACKBOARD
BEAVER GREENBOARD

SCHOOL FURNITURE
AND SUPPLIES—
OFFICE, BANK AND
COURTHOUSE FURNITURE—
THEATRE AND
AUDITORIUM SEATING

Rucker-Fuller Desk Co.

677 Mission St., SAN FRANCISCO, CAL.
434 Higgins Bldg., LOS ANGELES, CAL.
432 - 14th Street - OAKLAND, CAL.

ELECTRICAL MECHANICAL

BALDWIN DREW WARD
Consulting Engineer
Power and Industrial Plants

Associate Member A. I. E. E.

76 Eleventh St. Oakland, Cal.

RUSSWIN
BUILDERS' HARDWARE

JOOST BROS., Inc.
SAN FRANCISCO AGENTS.

We Carry Complete Stock:
Fishing Tackle—Guns—Mechanics' Tools—
Paints—Crockery and Glassware—Stoves—
Household Goods. Telephone Market 891.

NO BRANCH STORE
Mazda Lamps Electric Goods

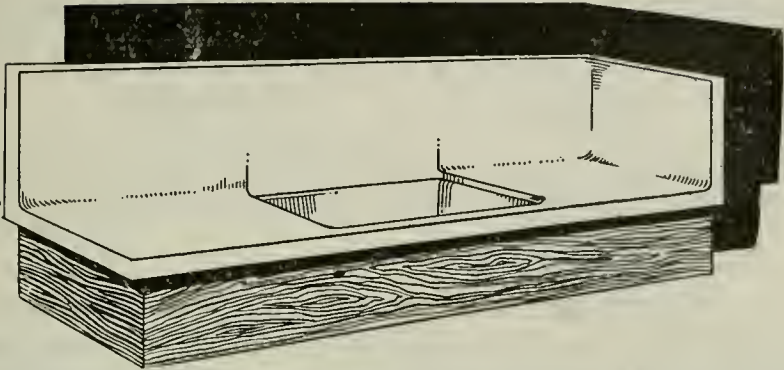

A Snow White Drain Board

PETRIUM SANITARY SINKS are made in Berkeley, California and are non-porous, non-absorbent and Lye-proof. The entire surface of the drainboard and back is covered with a composition, on which a smooth, glossy, snow white finish is applied mechanically leaving no crevice or corners in which dirt and grease can collect as where tile or wood is used.

Can be installed in any home—new or old.

PETRIUM SANITARY SINK COMPANY

FACTORY AND OFFICE, WEST BERKELEY

Agents in Principal Coast Cities

*Send for booklet
and Price List.*

The High Cost of Building Material Is a Strong Argument for Economy

Architects may keep down the
Cost by Economizing in Space



Hotel Cecil, San Francisco,
Equipped with Wall Beds.

Portal Wall Beds

are timely space and cost savers, meeting a national need. Those who would build wisely in these days of soaring prices, provide for **PORTAL WALL BEDS**

MARSHALL & STEARNS CO.

WALL BEDS

"HIGHEST AWARD ALWAYS"

1152 Phelan Building
San Francisco

1774 Broadway
Oakland

A. D. COLLMAN

P. F. SPEIDEL

COLLMAN AND SPEIDELGENERAL
CONTRACTINGCONSTRUCTION
ENGINEERS

Telephone SUTTER 4858

MONADNOCK BUILDING, SAN FRANCISCO

I. R. KISSEL

Phone Franklin 548

Decorator, Painter and Paperhanger

1747 SACRAMENTO ST., Bet. Polk St. and Van Ness Ave., SAN FRANCISCO

ROBERT TROST

PHONE MISSION 2209

General Building ContractorWe Specialize in High Grade Work and Employ Skilled
Labor in every Branch of the Building Industry.26th and Howard Streets
SAN FRANCISCO

P. A. Palmer

Peter Petersen

W. L. Kelly

PALMER & PETERSEN

Contracting Engineers

782-796 Monadnock Building

SAN FRANCISCO, CAL.

S. RASORI, RES. 2042 TAYLOR ST.
PHONE FRANKLIN 6258J. DEL FAVERO, RES. 1839 MASON ST.
PHONE FRANKLIN 9524**DEL FAVERO & RASORI**

GENERAL CONTRACTORS

MEMBERS OF THE S. F. BUILDERS EXCHANGE AND THE BUILDING INDUSTRIES ASS'N

OFFICE:
110 JESSIE STREET

SAN FRANCISCO, CALIF.

MONSON BROS.

GENERAL CONTRACTORS

Telephone Market 2693

1908 Bryant Street, San Francisco

UNIT CONSTRUCTION COMPANY

(INCORPORATED)

ENGINEERING AND CONSTRUCTION

Telephone Kearny 28

429-36 Phelan Building, SAN FRANCISCO

J. D. HANNAH

Contractor and Builder

OFFICE: 142 Sansome Street
San Francisco, Cal.Telephone Douglas 3895
BUILDERS EXCHANGE, 180 JESSIE STREET

I. M. SOMMER

CONTRACTOR & ENGINEER

Phone Kearny 4582

401 BALBOA BLDG., SAN FRANCISCO

K. E. PARKER COMPANY, Inc.

GENERAL CONTRACTORS

Phone Sutter 5661

Room 515 Clunie Building, SAN FRANCISCO

R. W. LITTLEFIELD
BUILDING CONSTRUCTION

357 12th Street, Room 9, Oakland, Cal.

Phone Lakeside 6750

H. H. HILP, Jr.

J. FRANK BARRETT

BARRETT & HILP

CONCRETE CONSTRUCTION BUILDERS GENERAL CONTRACTORS

SHARON BUILDING, SAN FRANCISCO

TELEPHONE SUTTER 1168 or 1169

Res. Phone Mission 5049

JAMES F. SMITH — Plasterer

273 Minna Street, San Francisco

Phone KEARNY 740

Member Builders Exchange

STEELFORMS Signify ECONOMY, RAPIDITY, and EFFICIENCY

STEELFORM CONTRACTING COMPANYSTEELFORMS FOR
CONCRETE
BUILDINGS

C. B. Hopkins, C. E., Manager

681 Market Street, San Francisco

CONCRETE JOIST
FLOOR
CONSTRUCTION**W. C. DUNCAN & CO.**

205 Sharon Bldg.

General Contractors

San Francisco

Telephone Kearny 772

M. E. VUKICEVICH

SPENCER B. BAGGE

VUKICEVICH & BAGGE

GENERAL CONTRACTORS

Phone Sutter 6700

Office, Builders Exchange, 180 Jessie St., San Francisco

245 Market St. **Standard Fence Co.** 310 Twelfth St.
 S. F. Kearny 2028 **WIRE AND IRON WORKS** Oakland 475

DESIGNERS - BUILDERS WIRE GRILL WORK—WIRE SCREEN
 FACTORY PROTECTION FENCE FLEXIBLE WIRE CONVEYOR BELT
 AVIARY AND TENNIS COURT FENCE WIRE SPECIALTIES

320 North Los Angeles Street, Los Angeles, Cal. Phone 67188

Steel Bars FOR CONCRETE REINFORCEMENT
 Cut to Length, Fabricated, Installed

BADT-FALK & CO.

Tel. Douglas 3466 346 Call-Post Bldg., 74 New Montgomery St., San Francisco

BUILDING DIRECTORIES [INTERCHANGEABLE STEEL
 LETTERS AND NUMBERS]
 FOR OFFICE BUILDINGS, SCHOOLS, CAFETERIAS, Etc.
 Bargains Lists for Auto Sales Companies. Sold Outright.

Go-Sign and Letter Manufacturing Co.

1106 Franklin Street Oakland, California

D. N. & E. WALTER & CO.
 "SINCE 1858"

LINOLEUMS—CARPETS LARGE STOCKS CARRIED
 Estimates furnished on request

562-572 MISSION STREET SAN FRANCISCO

Phone Merritt 668

H. N. McNAB

Hardwood Floors  Floor Sanding

2307 - 17th Ave. Oakland, Cal

Res. Tel. Merritt 3600

HERBERT BECKWITH
Building Construction

Formerly with ARTHUR ARLETT 323 Newton Ave.
 Oakland

D. ZELINSKY & SONS
 PAINTERS AND DECORATORS

420 TURK STREET, SAN FRANCISCO

CHARLES T. PHILLIPS
 CONSULTING ENGINEER

PACIFIC BUILDING SAN FRANCISCO
 HEATING VENTILATION WIRING ILLUMINATION

Ideal Air-Washers. Ideal Fruit-Dryers. Fan Systems for Heating, Cooling and Drying.

Ideal Heating and Engineering Co.

Air-Conditioning, Heating, Cooling and Drying

192 ERIE STREET

Phone Market 3708

SAN FRANCISCO

Atlas Heating and Ventilating Co., Inc.

ENGINEERS and CONTRACTORS

STEAM AND HOT WATER HEATING, FANS, BLOWERS,
FURNACES, POWER PLANTS—SHEET METAL WORK

Phone Douglas 378

Fourth and Freelon Sts., Bet. Bryant & Brannan, SAN FRANCISCO

Illinois Automatic Vacuum and Vapor Systems of Heating

"TWENTY-FIVE YEARS OF QUALITY"

ILLINOIS ENGINEERING COMPANY

JAS. I. KRUEGER, *Representative*

559-561 Pacific Building, San Francisco

Telephone: Kearny 3047

HEATING
VENTILATION

FLOOR AND WALL TILING

PLUMBING
SHEET METAL WORK

SCOTT CO., Inc.

SUCCESSOR TO JOHN G. SUTTON CO.

243 MINNA STREET

SAN FRANCISCO

ALEX COLEMAN

CONTRACTING PLUMBER

706 ELLIS ST., SAN FRANCISCO

Phone FRANKLIN 1006

WM. F. WILSON COMPANY

MODERN SANITARY APPLIANCES

Special Systems of Plumbing for Residences, Hotels, Schools, Colleges, Office Buildings, Etc.

Phone Sutter 357

328-330 Mason Street, San Francisco.

C. DRUCKER

J. C. JAMES

JAMES & DRUCKER

Plumbing—Heating—Contractors

Phone Market 275

450 Hayes Street, San Francisco, Cal.

The Granite Work on Eldorado County Courthouse; National Bank of D. O. Mills, Sacramento;—
and Sen. Nixon Mausoleum, Reno, WAS FURNISHED BY

CALIFORNIA GRANITE COMPANY

STONE CONTRACTORS

Phone Sutter 2646

Builders' Exchange, San Francisco

Main Office, Rocklin, Placer Co., Cal.

Quarries, Rocklin and Porterville

Telephone Main 82

GOODS OF QUALITY

A new syphon action closet at a moderate price that is not only ultra-efficient but pleasing in appearance and combining many new sanitary features.

On display at our show room—

64 Sutter Street, San Francisco

Main office and warehouse: Sixth, Townsend & Bluxome Sts.



Holbrook, Merrill & Stetson

Designers - Fabricators - Erectors

General Plate Work



Hydro - Pneumatic Pressure Tanks —
 Hemispherical Bottom Tanks and Towers
 — Oil and Water Tanks — Oil Stills —
 Pipe Lines—Smoke Stacks—Well Casing
 — Rock Screens — "Western" Corru-
 gated Culvert Pipe.

Western Pipe and Steel Company

OF CALIFORNIA

444 MARKET STREET
 SAN FRANCISCO

1758 NORTH BROADWAY
 LOS ANGELES



IT'S not enough to say "Good For All Time" unless there is something back of it. There is in this case. Vermont Marble already has an unblemished record of over one hundred and fifty years. We know what it will do. It's not necessary to guess at it. And our quarries in Alaska and Texas are also proving themselves. So please don't think of "Good for All Time" as merely a happy phrase.

IT'S THE MARK OF A SERVICE.
It means exactly what it says.

VERMONT MARBLE COMPANY
PROCTOR, VERMONT
San Francisco - Portland - Tacoma

LA FRANCE SAFETY DEVICES
FOR EVERY INDUSTRY

Consider Fire Protection
in Making Your Plans



If you are planning a factory provide a space for a LaFrance No. 20 Chemical Engine, for it is simple in construction and easy to operate. It contains twenty gallons of fluid forty times as effective as water for extinguishing fires. It is made by the world's largest manufacturer of fire apparatus,

with a full knowledge of what is best for effective fire fighting.

Write for complete information in regard to this and our other appliances, such as Hose, Hose Racks, Reels, Nozzles, Axes and many others.

AMERICAN LA FRANCE FIRE ENGINE COMPANY, INC.

ELMIRA, N. Y.

929 South Hill Street,
Los Angeles, Calif.



151 New Montgomery
Street, San Francisco,
Calif.

QUEBRACHO!

One coat Argentine Quebracho paint on steel will outwear three of red lead and graphite at fraction of cost. Contains South American gum that gives great tenacity. Ask about records on steel; also for damp-proofing concrete and for protecting piling from teredo.

IMP MANUFACTURING CO.
Plaza Building, Oakland Phone Lakeside 478

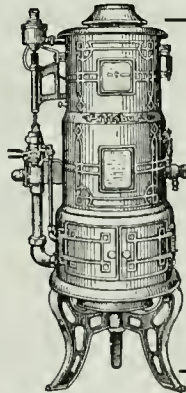

Pittsburg

It Insures
Instant
Hot Water
Service

**PITTSBURG WATER
HEATER COMPANY**
478 Sutter St., San Francisco
Phone Sutter 5025

**Business Systems
Office Furniture**

F. W. WENTWORTH & CO.
Distributors for **LIBRARY BUREAU**
539 Market Street, San Francisco
LOS ANGELES OAKLAND SEATTLE

WIRING



185 Stevenson Street, San Francisco
Phone Douglas 4832

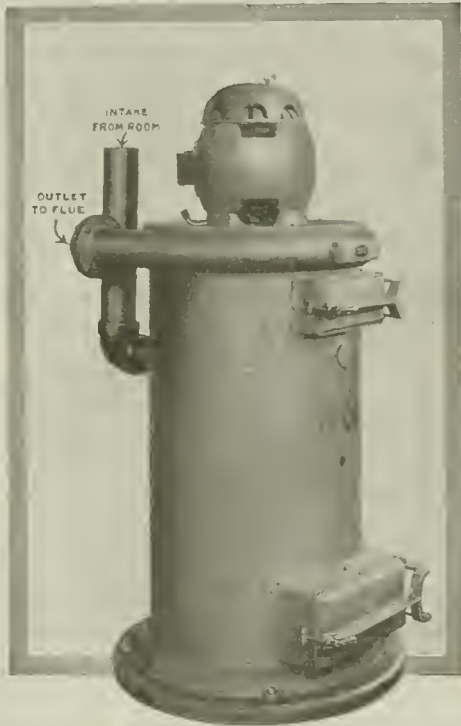

TUEC STATIONARY CLEANER.

THE cleaner that reduces building maintenance expense by keeping floors, walls, stairways, merchandise and other stocks, carpets, furniture and furnishings free from dust and dirt. No other cleaning device or dust removal method is so thorough, efficient, and economical. Investigate yourself and invite your client to do so. Write for our free catalog and full information.

THE UNITED ELECTRIC CO.

CANTON, OHIO.

Canadian Plant: Toronto, Ont.

California Distributors

S. F. COMPRESSED AIR CLEANING CO.
397 Sutter Street, San Francisco

BARKER BROS.
724 S. Broadway, Los Angeles



POSITIVE ELECTRIC INTERLOCK

(BAR LOCK TYPE)

Prevents Elevator Accidents Occurring at the Entrance Door

Approved by National Underwriters Laboratories—Meets requirements of Elevator Safety Orders of Industrial Accident Commission, State of California

ELEVATOR SUPPLIES COMPANY, Inc. 186 FIFTH STREET, SAN FRANCISCO

Capital \$1,000,000

CALIFORNIA DEPARTMENT

Surplus \$1,122,000

THE FIDELITY AND CASUALTY COMPANY OF NEW YORK

Prompt Service for

BONDS AND CASUALTY INSURANCE

203-206 Merchants Exchange Building

SAN FRANCISCO, CAL.

ANY PLACE ANY TIME PROMPTLY "We Serve You"

JOHN H. ROBERTSON

Successor to Robertson & Hall

GENERAL INSURANCE

Phone Sutter 2750

621 First National Bank Building, San Francisco

CONTRACT BONDS

Fidelity and Surety Bonds of every kind.

C. K. BENNETT, Manager

FIDELITY AND DEPOSIT COMPANY OF MARYLAND

Telephone Kearny 1452

622 Insurance Exchange, San Francisco, Calif.

PACIFIC DEPARTMENT

Globe Indemnity Company

BONDS and CASUALTY INSURANCE for CONTRACTORS

FRANK M. HALL, formerly Robertson & Hall, Mgr.

120 Leidesdorff Street Phone Sutter 2280 SAN FRANCISCO

National Surety Company of New York

The World's Largest Surety Company

Assets over \$20,000,000

Pacific Coast Department: 105 MONTGOMERY ST., SAN FRANCISCO, CAL.

Frank L. Gilbert, Vice-President

Phone, Sutter 2636

PHONE DOUGLAS 2370

McLERAN & PETERSON

GENERAL CONTRACTORS

HEARST BUILDING

SAN FRANCISCO, CAL.

L. J. RUEGG

J. B. RUEGG

RUEGG BROS.

CONTRACTORS AND BUILDERS

Phone Douglas 1599

719 Pacific Building, SAN FRANCISCO



Steel ^{Open} ^{Hearth} Bars ^{For Concrete} ^{Reinforcement}

Square, Deformed and Cold Twisted, Plain Rounds and Squares

PACIFIC COAST STEEL COMPANY

General Office, Rialto Building, San Francisco. Phone Sutter 1564

Sales Office, Rialto Building, SAN FRANCISCO
 Sales Office, Union Oil Building, LOS ANGELES
 Sales Office.....SEATTLE, WASH.

ROLLING MILLS:
 SOUTH SAN FRANCISCO.....CAL.
 SEATTLE, WASH. PORTLAND, ORE.

Architects and Building Contractors!

The HICKS-JUDD COMPANY, Inc., and SUNSET PUBLISHING HOUSE
 have consolidated under the name of
 ABBOTT-BRADY PRINTING CORPORATION
 460 Fourth Street, San Francisco, Calif.

THE Binding of Magazines and Periodicals
 will continue as one of Our Specialties;
 also Expert Plate and Map Mounting.

Reprinting of The Architect and Engineer Advertisements for Circular or File Use

George S. MacGruer } Members of Builders Exchange
 Robert M. Simpson }

MacGruer & Simpson

CONTRACTING PLASTERERS
 PLAIN AND ORNAMENTAL

Cement, Stucco and Artificial Stone

Phone Sutter 5688

540 Call-Post Building, San Francisco

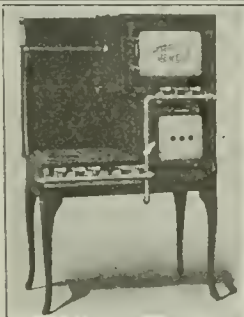

Detroit Jewel Gas Ranges

FOR HOME, RESTAURANT, HOTEL AND CLUB

We carry a Full Line of Stock Sizes

SELLING AGENTS

NATHAN DOHRMANN CO.

Geary and Stockton Streets, San Francisco

PARMELEE-DOHRMANN CO.

436-444 S. BROADWAY, LOS ANGELES

CALIFORNIA ARTISTIC METAL & WIRE CO.
 J. T. MCCORMICK, PRESIDENT
 ORNAMENTAL IRON AND BRONZE
 349-365 SEVENTH ST. SAN FRANCISCO

MORTENSON CONSTRUCTION CO.
 CONTRACTORS FOR STRUCTURAL STEEL AND IRON
 H. MORTENSON, PRES. CHAS. G. MORTENSON, VICE-PRES. AND MGR.
 OFFICE AND SHOPS: CORNER 19TH AND INDIANA STREETS
 PHONE: MISSION 5033 SAN FRANCISCO, CAL.

RAYMOND GRANITE COMPANY, Inc.
 Owning and operating at Knowles, Madera County, the largest Quarry in the world
 CONTRACTORS FOR STONE WORK
 Designers and Manufacturers of Exclusive Monuments and Mausoleums
 Main Office and Yard: No. 1 and 3 Potrero Avenue, San Francisco, California
 Also at 1350-Palmetto Street, Los Angeles

CAEN STONE  **A. KNOWLES**
 A refined, elegant, interior finish. CONTRACTOR and PLASTERER
 442 Call-Post Building San Francisco

THE GOLDEN GATE IRON WORKS
STRUCTURAL STEEL
 1541-1549 HOWARD STREET, BETWEEN 11th AND 12th STREETS
 Tel. Market 5445 San Francisco

Telephone Mission 58 A. A. Devoto, President
CENTRAL IRON WORKS, Inc.
 STRUCTURAL STEEL
 Office 2050 BRYANT STREET SAN FRANCISCO, CAL.

JOHNS-MANVILLE
 SERVES IN CONSERVATION
 Through
ASBESTOS and its ALLIED PRODUCTS

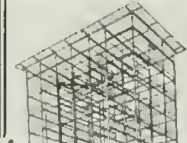
 **SCHRADER IRON WORKS, Inc.**
 STRUCTURAL STEEL CONTRACTORS
 Fire Escapes, Waterproof Trap Doors, Ornamental Iron Work
 1247-1249 HARRISON STREET SAN FRANCISCO, CAL.
 Bet. 8th and 9th Telephone Market 337

THE HYLOPLATE BLACKBOARD

SCHOOL FURNITURE
AUDITORIUM SEATING

MAPS
GLOBES
ATLASES

C. F. WEBER & CO.

985 Market Street
SAN FRANCISCO



222-224
S. Los Angeles St.
LOS ANGELES

100 W. Commercial
Row, RENO, NEV.

524 W. Washington
Street, PHOENIX, ARIZ.

Durability

Redwood gives the best service for all industrial construction, especially where exposed to the elements or in contact with the ground.

Nature impregnates Redwood with a natural preservative that resists rot. Redwood lasts longer untreated than most woods when artificially preserved.

Write for "Redwood Lives Forever," "California Redwood for the Engineer," and "Redwood Block Paving and Flooring."

CALIFORNIA REDWOOD ASSOCIATION

San Francisco

California Redwood

Resists fire and rot



Formal Garden Effects

may be obtained on your Country Estate within a period of two or three years.

MacRORIE-McLAREN CO.

141 Powell Street, San Francisco
Telephone Douglas 4442

WASH in tempered running water by installing

Crane "Sultana" Double Basin Faucet

FOR NEW AND OLD INSTALLATIONS

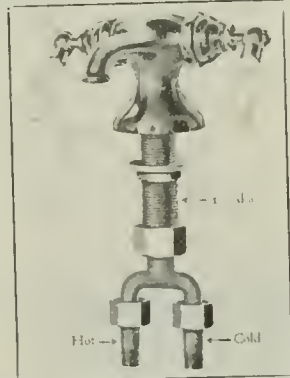

FOR HOME—OFFICE—FACTORY

"SULTANA" can be installed on practically all lavatories cut for two basin faucets. It is an ideal faucet to install when making alterations.

CRANE CO.
PLUMBING SUPPLIES
SAN FRANCISCO AND OAKLAND

<p>Telephone DOUGLAS 2046</p>	<p>Butte Electrical Equipment Company</p> <h1 style="margin: 0;">BEECO</h1> <p style="font-size: small; margin: 0;">TRADE MARK-REG</p>	<p>530 FOLSOM STREET</p>
<p>CONTRACTORS FOR POWER LIGHTING AND INDUSTRIAL INSTALLATIONS</p> <p>For the convenience and guidance of our customers, we have adopted BEECO as our trade name.</p>		

<h1 style="margin: 0;">SAFETY ELECTRIC COMPANY</h1> <p style="font-size: small; margin: 0;">MANUFACTURERS OF</p>		
<p>SWITCHBOARDS SAFETY SWITCHES SAFETY CONTROLS</p>		<p>PANEL BOARDS SAFETY PANELS KNIFE SWITCHES</p>
<p>59-65 Columbia Square</p>		<p>San Francisco, Calif. Telephone Market 2949</p>

L. SIEBERT	J. GENSLER
<h1 style="margin: 0;">Drendell Electrical & Mfg. Co.</h1> <p style="font-size: small; margin: 0;">Incorporated</p> <p style="margin: 0;">SWITCHBOARDS, PANEL BOARDS, KNIFE SWITCHES, CABINETS, THEATRE INSTALLATIONS, PROTECTIVE POWER PANELS</p>	
1345-1353 Howard St., San Francisco	Telephone Market 1753

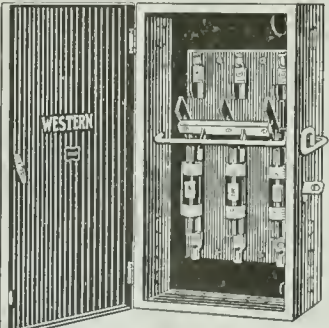
 <p style="font-size: x-small; margin-top: 5px;">"TYPE C"</p>	<h2 style="margin: 0;">Western Safety Man'fg. Co. Inc.</h2> <p style="font-size: x-small; margin: 0;">Formerly <u>MEYERS ELECTRIC SAFETY SWITCH CO., Inc.</u></p> <p style="font-size: x-small; margin: 0;">Manufacturers of</p> <p style="margin: 0;">Enclosed Externally Operated Safety Switches, Knife Switches, Metal Switch and Cut Out Boxes, Safety Switch Boards</p> <p style="margin: 0;">Office, 247 Minna Street SAN FRANCISCO Telephone, Sutter 3008</p>
---	--

BUTTE ELECTRIC & MFG. CO. DOUGLAS 145

(Paul C. Butte) at it since 1904

WIRING FOR BUILDINGS

534 Folsom Street

SAN FRANCISCO

H. S. TITTLE

CONTRACTING ELECTRICAL ENGINEER

766 FOLSOM ST., SAN FRANCISCO

Phone SUTTER 4278



To Be "Low Bidder" Not Always Our Aim.

Our most particular attention is given to prompt and skillful handling of all electrical work of any nature with "QUALITY AND SERVICE GUARANTEED."

Our nation-wide organization and large experience in this field assures you always of fair estimates and absolute satisfaction.

F. E. NEWBERY ELECTRIC CO.

163 Sutter St. (413 Lick Bldg.) San Francisco, Phone Sutter 521

San Francisco, Cal.

Oakland, Cal.

Los Angeles, Cal.

NE PAGE, McKENNY CO.

Electrical Engineers and Contractors

Phone Sutter 2369

589 Howard St., San Francisco, Cal.

Phone Market 2541

M. FLATLAND

GLOBE ELECTRIC WORKS

Estimates Furnished on Everything Electrical

ELECTRIC SUPPLIES

1959 Mission Street, bet. 15th and 16th

SAN FRANCISCO

E. E. BROWNE

Telephone Douglas 976

C. A. LANGLAIS

**BROWNE-LANGLAIS ELECTRICAL
CONSTRUCTION COMPANY**

213 Minna Street

SAN FRANCISCO

M. E. RYAN

Electrical Contractor

Phones: Store, Red. 250J
Residence, Red. 250M

216 Main Street
REDWOOD CITY, CAL.

CHAS. G. FRIES.

TELEPHONE SUTTER 5706

VICTOR A. KUEHN

LIBERTY ELECTRIC COMPANY

479 Sutter St. Electrical Contractors San Francisco, Cal.

Oakland 540

The Largest Exclusive Electrical House in the State

MOTORS

BOUGHT — SOLD
RENTED — REPAIRED

Lighting Fixtures

Manufactured

Construction

MAINTENANCE
SUPPLIES

Estimates and engineering data cheerfully furnished

SPOTT ELECTRICAL CO.

Yours for Service

16th & CLAY STREETS

OAKLAND, CALIFORNIA

KLINGSTONE

WILL NOT CRACK

Modern Flooring Requirements

In this day of modern building construction, sanitary and fireproof requirements are sought by the architect in building specifications.

Klingstone Sanitary Flooring Rates 82%

—Cork tile, 72%; linoleum, 70%; oak or maple, 63%; white pine 62%; marble, 52%; rubber tile, 49%; clay tile, 43%; terrazo 43%; Portland Cement concrete, 42%; common brick rating 25%. KLINGSTONE SANITARY FLOORING is being extensively used in modern office buildings, schools, hospitals, factories, churches, railroad cars, steamships, hotels, public buildings, theatres, banks, stores, restaurants, cafes, garages, dairies, creameries, high-class residences and apartment houses.

GUARANTEE. — We rigidly guarantee our KLINGSTONE Sanitary Flooring, and where applied according to our printed specifications, will replace, free of charge, any defective material, including labor for installing same.

NATIONAL MAGNESITE PRODUCTS CORPORATION

833 MARKET STREET, SAN FRANCISCO

A. H. Bergstrom
Eric Lange

Phone Kearny 3526

LANGE & BERGSTROM

Building Contractors

(Established 1900)

207-210 SHARON BUILDING
San Francisco

TIMKEN BUILDING
San Diego

CONTRACTOR'S MACHINERY

RANSOME MIXERS

OSHKOSH MIXERS

INSLEY SPOUTING PLANTS

OSHKOSH EVEREADY SAW RIGS INSLEY STEEL CARS and TRACKS

HOISTING BUCKETS, HOPPERS, GATES, ETC.

STEAM AND ELECTRIC HOISTS

EVERYTHING USED BY CONTRACTORS

CARRIED IN STOCK BY

GARFIELD & CO.

Hearst Building, San Francisco

Phone Sutter 1036

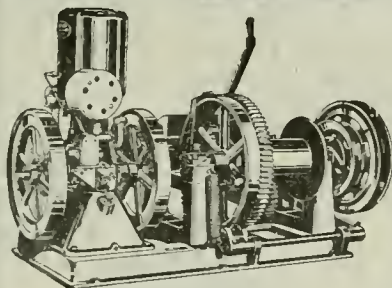

NOVO HOIST -- TYPE T.

NOVO ENGINES

ALWAYS

SATISFY

BUILT IN SIZES

1½ TO 15 H. P.

We have a Hoist for every requirement of
the Mine, Factory or Contractor.

NOVO OUTFITS

comprise Contractor's Pumps—Hoists
Compressors—Saw Rigs, Etc.



STOCKS ALWAYS ON HAND

SMITH-BOOTH-USHER-CO.

PUMPS — ENGINES — MOTORS — MACHINERY — SUPPLIES

San Francisco
50-60 Fremont St. Sutter 952

Taft
Supply Row

Los Angeles
228 Central Ave. M2695

School and Theatre

STAGES AND EQUIPMENT

EDWIN H. FLAGG

SCENIC COMPANY, Inc.
400 Pantages Bldg., San Francisco, Cal.
1638 Long Beach Ave., Los Angeles, Cal.

MILLWORK Manufactured and Delivered Anywhere

Plans or Lists sent us for Estimates will have Careful and Immediate Attention.

Jno. Dudfield, Pres.
and Manager

DUDFIELD LUMBER CO.

Joseph A. Jury,
Sec'y & Mill Supt.

MAIN OFFICE, YARD AND PLANING MILL — PALO ALTO, CALIFORNIA

FRANK PORTMAN

MILL AND CABINET WORK

Window Frames and Inside Finish A Specialty
Band Sawing, Sticking and Sand Papering

1618-20 MISSION STREET

SAN FRANCISCO

ALL KINDS OF
MOULDINGS
IN STOCK

Phone Park 6204

A. C. SCHINDLER, President.

CHAS. F. STAUFFACHER, Secretary

THE FINK & SCHINDLER CO.

Manufacturers of INTERIOR WOODWORK AND FIXTURES
BANK, OFFICE AND STORE FITTINGS
SPECIAL FURNITURE

218-228 THIRTEENTH ST.
Bet. Mission and Howard Sts.

SAN FRANCISCO, CAL.
Telephone: Market 474

O. BAMANN, President

ERNEST HELD, Vice-President

HOME MANUFACTURING CO.

BANK, STORE AND OFFICE FITTINGS
FURNITURE AND HARDWOOD INTERIORS
CABINET WORK OF EVERY DESCRIPTION

543 and 545 BRANNAN ST.

Phone Kearny 1514

San Francisco, Cal.

JAMES L. McLAUGHLIN

GENERAL CONTRACTOR

Phone Kearny 1654

251 KEARNY STREET, SAN FRANCISCO

MULLEN MANUFACTURING CO.

BANK, STORE AND OFFICE FIXTURES—CABINET WORK OF
GUARANTEED QUALITY—CHURCH SEATING

Telephone Market 8692

Office and Factory:

64 Rausch St., Bet. 7th and 8th Sts., San Francisco

Dolan Wrecking & Construction Co.

(D. J. DOLAN)

Lumber, Lath, Nails, Shingles, Doors, Windows
and Plumbing Supplies, New and Second Hand

Phone Market 4264

Office and Yard, 1607-1639 MARKET ST., SAN FRANCISCO

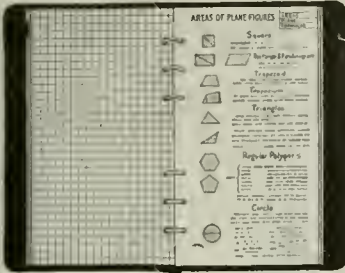

LEFAX

LEAF + FACTS

Pocket Cyclopedias

The facts that you want *instantly available* are not the same ones that some one else in your profession might desire. That's why LEFAX is made Loose Leaf. You file, in whatever order you wish, those sheets of facts that you want to have constantly at hand. If you wish, you may also file, in the same book, sheets for keeping data, for figuring, etc.

LEFAX sets cost but 50c. and \$1.00. You cannot fully appreciate their handiness—their value—until you use them. Ask us about them.

SCHWABACHER-FREY STATIONERY CO.
 PRINTERS LITHOGRAPHERS STATIONERS
 611 Market Street San Francisco

Steam Heating and Ventilating



For Commercial and Public Buildings

Furnace Heating
 For the Home

Mangrum & Otter, Inc.

827-831 Mission Street
 Phone Kearny 3155 SAN FRANCISCO

"Talk—Don't Walk"

Paker, Hamilton & Pacific Co.; California Packing Corporation; J. Barth & Company; Robert Dollar Company; Bass-Hueter Paint Co.; Sperry Flour Company, So. Vallejo; J. D. & A. B. Spreckles Securities Co.

WHY are the above firms using the AUTOMATIC PRIVATE TELEPHONE SYSTEM?

BALFOUR, GUTHRIE Co.; HOWARD AUTOMOBILE COMPANY; U. S. MARINE HOSPITAL KNOW WHY, and are also installing the AUTOMATIC PRIVATE TELEPHONE SYSTEM.



DIRECT-LINE TELEPHONE COMPANY

Telephone Electrical Engineers

THEODORE HALL, MANAGER

320 MARKET STREET, SAN FRANCISCO
 Phone Douglas 722

Have you read "A Pair of Wires and A Dial?"

ROBERTS MFG. CO.

Lighting Fixtures
 Electric Appliances
 Incandescent Lamps

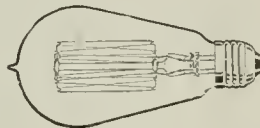

WILLYS FARM LIGHTING AND POWER PLANTS

663 Mission St., San Francisco

Washed Gravel and Sand

Quality For Concrete Construction *Service*

Thoroughly Washed and Accurately Graded — An Ideal Concrete Aggregate



View of Plant at Niles

California Building Material Co.

Plants at Eliot and Niles, Cal.

500 Call Building, San Francisco

Otis Elevators

THE Architect or Engineer can specify "Otis Elevators" assured that the responsibility of the Otis Elevator Company extends beyond satisfactory installation. Buildings equipped with Otis Elevators enjoy the advantage of the prompt service and careful inspection rendered by any of our hundred offices. Such service means your clients' gratitude.



Otis Elevator Company

Offices in All Principal Cities of the World
2300 Stockton Street, San Francisco, Calif.

The
ARCHITECT &
ENGINEER



MARCH 1921

Published in San Francisco
35 cents a copy - \$2⁵⁰ a year



Opportunity



The country's building program is five years behind.

An era of construction, of great proportions is just starting.

We trust that, during the prosperous days ahead, you will continue to specify

PACIFIC **PLUMBING FIXTURES**

For Sale by All Jobbers

OFFICES: 67 NEW MONTGOMERY STREET, SAN FRANCISCO
FACTORIES: SAN PABLO AND RICHMOND, CALIFORNIA

Beware of a "Cheap" Roof

Not only disappointment and annoyance, but very often actual damage results when a building is covered with a *cheap* roof. Like most so-called "bargains," a cheap roof falls short in service and is, in the long run, far more expensive than a good roof.

PABCO Roofs Guaranteed for 10 and 20 Years

appeal to Architects, Engineers, and owners because of the high quality of materials, the proved method of construction, and particularly because they are least expensive due to the *low cost per year of service*.

Write for Specifications and
Complete Details

THE PARAFFINE COMPANIES, INC.
San Francisco, California

*Younie Building, Susanville, California
covered with a PABCO 10-Year Roof*



Roofings—Felts
Roof Coatings
Building Papers
Floor Covering
Wall-Boards
Waterproofing
Materials
Paints
Box-Board
Paper Boxes
Fibre Containers

C. O. Clausen,
Architect
S. F.

A. E. Kibble
Roofing Contractor
Reno, Nevada



When writing to Advertisers please mention this magazine.

Clocks were Never Needed 'Til Time Acquired a Value



"ISH-KA-
BIBBLE"



Electric Clock and Program Bell Systems,
Automatic Control of Time Keeping Devices
for Schools, Hospitals, Public and Private
Buildings, Banks Etc., Automatic Calling
Systems

Please Note

Right here on the Pacific Coast we are manufacturing and distributing Electric Clocks, designed and engineered by J. J. Estabrook, a man who knows how, with twenty-five years' experience—nine years on the Pacific Coast.

Plans, specifications and any engineering information, estimates, etc., cheerfully furnished to architects, engineers or any one interested in this special line of work.

SERVICE

is our motto

PACIFIC ELECTRIC CLOCK CO.

J. J. ESTABROOK

516 Wells Fargo Building

San Francisco, Calif. Telephone Sutter 803

General Machinery & Supply Co.

OFFICES AND STORE: 39-51 STEVENSON STREET

TELEPHONE - PRIVATE EXCHANGE - SUTTER 6750

— AGENTS FOR —

EVERLASTING BLOW-OFF VALVES

WM. POWELL CO.'S { WHITE STAR VALVES - MODEL STAR VALVES
UNION COMPOSITE DISC VALVES AND PILOT GATE VALVES

YALE & TOWNE:—CHAIN HOISTS

FISHER AND SWARTWOUT STEAM SPECIALTIES

ENGINEER'S, MACHINIST'S AND STEAM FITTER'S SUPPLIES

PIPE, PIPE-FITTINGS, VALVES, BELTING, PACKING AND HOSE

TRANSMISSION AND CONVEYING MACHINERY

SEND US YOUR INQUIRIES

A simple explanation of what Elexits are

An Elexit, the flush receptacle which takes wall bracket supporting plugs, chandelier supporting plugs or ordinary attachment plugs, as desired.



An Elexit Wall Plug for attachment to the wires of any type of wall bracket.



Cap of standard attachment plug which fits Elexits and is now found on most electrical appliances.



An Elexit Ceiling Plug, which takes the place of canopy and wiring connections, and makes a chandelier lock itself securely by its own weight into an Elexit.

ELEXITS are standardized "electric exits" or outlets which are finished off with an inconspicuous flush receptacle with either a rectangular or circular plate.

The face of the Elexit receptacle is a rounded triangle with two parallel slots in its surface, the right hand slot being taller than the other.

They are designed to receive either wall or ceiling standardized fixture-supporting plugs or the standardized attachment plug now found on practically all electrical appliances.

Elexit receptacles can be installed in nearly all types of outlet boxes. Plugs for Elexits, attached to present-day lighting fixtures, make them at once movable, changeable, detachable by simply plugging into and out of Elexits.

How Elexits are used

Any type of wall bracket may be equipped for plugging into Elexits by simply attaching the wires to an Elexit wall plug.

Most ornamental brackets are made with a bridge across the back. This bridge is simply slipped over the lip on the top of the plug after the plug is inserted in the Elexit. The curvature of the blades makes it impossible to withdraw the plug without first unhooking the bracket.

On all other types of brackets a simple adaptor that fits the lip of the Elexit wall plug is substituted for the usual hickey or crowfoot. If desired, the adaptor may be rigidly attached to the plug, in which case it is only necessary to slip



Phantom view of an Elexit Wall Plug in place. A bracket mounted on this plug rests securely against the wall. Gravity takes up all play. Also showing the adaptor which replaces the hickey or crowfoot behind slip canopies.

back the canopy in order to plug the fixture into Elexits and then push the canopy back into place.

The chief interest in a chandelier is usually some distance below the point of attachment. When Elexits are installed in ceilings, their finished construction and appearance does away with the canopies which have heretofore been necessary to hide unsightly wiring connections.

The Elexit ceiling plug is therefore of finished appearance and may be treated as a part of the fixture-hanger. It is a split plug, one wire being attached to each half. A chandelier, equipped with this plug, is installed by inserting each half of the plug separately and hanging the fixture on the reversely curved hooks, as they are brought together. The weight of the fixture locks it securely.

What Elexits Accomplish

Elexits make lighting fixtures portable. They permit the expression of personal taste and individual preference in the selection and placing of lighting fixtures.

They allow for unlimited changing of lighting schemes to harmonize with rearrangement of furniture or decorations.

They provide for the safe use of lighting outlets for a double purpose, as an appliance may be plugged into an Elexit if it is not being used for lighting purposes. Names and addresses of manufacturers licensed to make Elexit receptacles and appliances will be furnished upon request, as will any further details regarding the use of Elexits.



Phantom view of Elexit Ceiling Plug in place. This provides stronger support than the average fixture chain. The mechanical strength of Elexits insures unusually good electrical connections.

ELECTRIC OUTLET COMPANY Inc. 119 West 40th St., New York City

When writing to Advertisers please mention this magazine.

W. & J. SLOANE

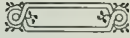

Carpetings Furniture
Rugs
Linoleum Window Shades
Wall Papers
Interior Decorations

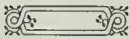

216-228 Sutter Street

Tel. Garfield 2838 San Francisco

When Choosing Electric
Time Equipment you
certainly want
THE BEST.

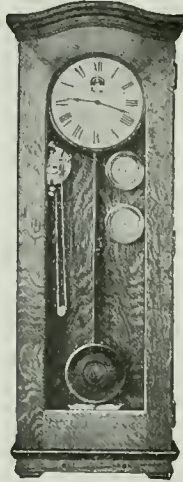

"Standard" electric time equipment watches over the precious minutes of school days, preventing too much time being used for one subject at the expense of another, simplifying the whole school routine and promoting punctuality, and efficiency among both pupils and teachers. Perfected through 36 years' experience. Each equipment carefully engineered to fit requirements. Helpful co-operation furnished architects, contractors, and school boards, insuring satisfaction.

**STANDARD ELECTRIC
TIME COMPANY**

461 MARKET STREET

Phone Sutter 241 SAN FRANCISCO

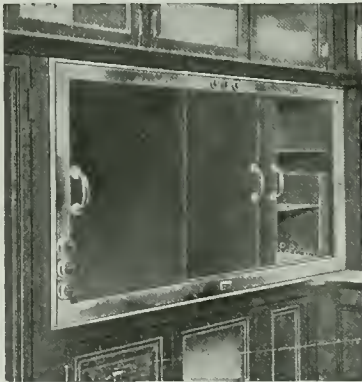

PROMETHEUS

The Electric Food and Plate Warmer
Wherever meals are cooked and served, in apartments, residences and institutions, Prometheus is a highly valued asset. The wireless heating units placed independently of the shelves keep food hot and tasty until ready to serve and cannot injure the finest china.

Write for information and list of installations

The Prometheus Electric Co.

Manufacturers

511 West 42d Street, New York

Showroom, **M. E. HAMMOND**
Mezzanine Floor Pacific Bldg., San Francisco



IT'S not enough to say "Good For All Time" unless there is something back of it. ☞ There is in this case. ☞ Vermont Marble already has an unblemished record of over one hundred and fifty years. ☞ We know what it will do. It's not necessary to guess at it. ☞ And our quarries in Alaska and Texas are also proving themselves. ☞ So please don't think of "Good for All Time" as merely a happy phrase.

IT'S THE MARK OF A SERVICE.
It means exactly what it says.

Vermont Marble Company
PROCTOR, VERMONT

San Francisco - Portland - Tacoma

STEEL BARS

FOR

CONCRETE REINFORCEMENT

CORRUGATED
TWISTED
SQUARES
OR
ROUNDS
CUT
TO
LENGTH



FABRICATED
AND
INSTALLED
—
LUMP SUM
BIDS
ON
WORK
COMPLETE

Office, 444 MARKET STREET
Warehouse, 10th and Bryant Streets
Phone: Sutter 2720

“HYDRATITE” FOR WATERPROOFING AND HARDENING CONCRETE “HORNSTONE”



Better Hangers for Garage Doors



Garage doors hung on R-W Slydasyde

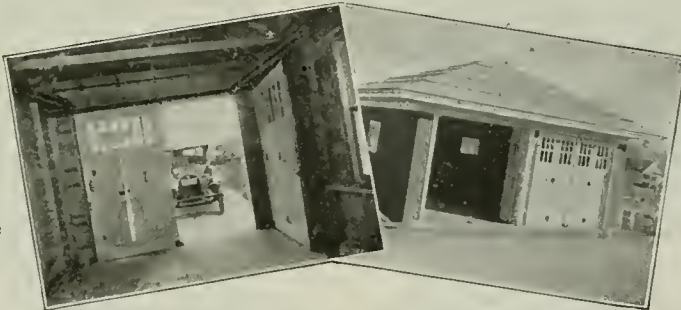

Garage door hung on R-W Slidetite

Architects and builders — specify R-W garage door hangers for better appearance — greater convenience — longer life. The Standard of America for all that means real satisfaction.

Send for special catalogue — O. A22



Richards-Wilcox Mfg. Co.

A Hanger for any Door that Slides.

CHICAGO ST. LOUIS LOS ANGELES PHILADELPHIA
AURORA, ILLINOIS, U.S.A.
BOSTON NEW YORK MINNEAPOLIS SAN FRANCISCO



E. B. Noble, President
A. E. Wilkins, Vice-Pres.

Beam, Angle, Channels, and Universal Mill
Plates for immediate shipment from stock

Pacific Rolling Mill Co.

SUPPLIERS OF

**FABRICATED STRUCTURAL STEEL, Forgings,
Bolts, Rivets, Frogs, Switches, Cast Iron Castings**

General Office and Works
17th and MISSISSIPPI STS., SAN FRANCISCO
Telephone Market 215

Beams
Channels
Angles
Plates

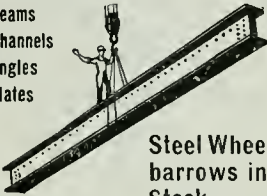

Steel Wheel-
barrows in
Stock

Western Iron Works

W. B. MORRIS, Pres. H. H. MORRIS, V.-P. L. J. GATES, Sec.

**STRUCTURAL IRON AND
STEEL CONTRACTORS**

141-147 Beale St. and 132-148 Main St. SAN FRANCISCO

Phones: GARFIELD 2575--2576

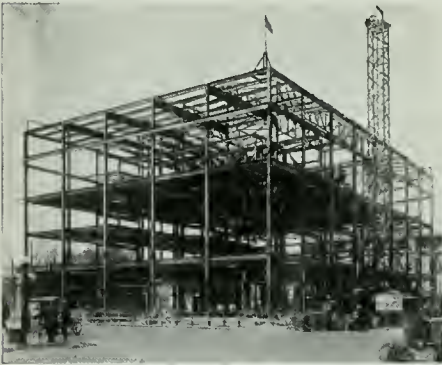

STEEL FRAME, MASONIC TEMPLE,
Sacramento. R. A. HEROLD, Architect.

STRUCTURAL STEEL
(600 tons) Fabricated and
Erected by

**THE PALM IRON AND
BRIDGE WORKS** (Incorporated)
15th and R Streets, Sacramento, Cal.

Cast Iron Stairs and Store Fronts

Bank and Office Railings, Elevator
Enclosures and Fire Escapes.

C. J. HILLARD CO., Inc.

Nineteenth and Minnesota Streets
Telephone Mission 1763

SAN FRANCISCO, CAL.

Architects' Specification Index

(For Index to Advertisements, see next page)

ART METAL

American Art Metal Works, 13 Grace street, San Francisco.

ARCHITECTURAL TERRA COTTA

Gladding, McBean & Company, Crocker Bldg., San Francisco.

Livermore Fire Brick Works, 604 Mission street, San Francisco.

ASBESTOS ROOFING, PACKING, ETC.

H. H. Robertson Co., Hobart Bldg., San Francisco.

H. W. Johns-Manville Co., San Francisco, Los Angeles and Portland, Ore.

AUTOMATIC SPRINKLERS

Grinnell Co. of the Pacific, 453 Mission St., San Francisco.

Pacific Fire Extinguisher Co., 424 Howard St., San Francisco.

AUTOMOBILE INSURANCE

Bankers & Shippers Insurance Co. of New York, Insurance Exchange Bldg., San Francisco.

AUTOMOBILES

W. L. Hughson Co., Geary St., at Van Ness Ave., San Francisco.

AWNINGS, TENTS, ETC.

W. A. Plummer, Front, at Pine St., San Francisco.

BANKS

First National Bank, Post and Montgomery streets, San Francisco.

BANK FIXTURES AND INTERIORS

Fink & Schindler, 218 13th St., San Francisco.

C. F. Weber & Co., 935 Market St., San Francisco.

Home Mfg. Co., 543 Brannan St., San Francisco.

Mullen Manufacturing Co., 64 Rausch St., San Francisco.

Rucker-Fuller Desk Co., 677 Mission St., San Francisco.

Pacific Manufacturing Company, San Francisco, Los Angeles, Oakland and Santa Clara.

BELTING AND PACKING

New York Belting and Packing Company, 519 Mission St., San Francisco.

H. N. Cook Belting Co., 401 Howard St., San Francisco.

Smith-Booth-Usher Co., San Francisco and Los Angeles.

BLACKBOARDS

C. F. Weber & Co., 935 Market St., San Francisco, Los Angeles and Reno, Nevada.

Beaver Blackboards and Greenboards, Rucker-Fuller Desk Company, Coast agents, 677 Mission St., San Francisco; also Oakland and Los Angeles.

BLINDS—VENETIAN AND DIFFUSELITE

J. G. Wilson Corporation, Metropolitan Bldg., Los Angeles; Waterhouse-Wilcox, Underwood Bldg., San Francisco.

Western Venetian Blind Co., Long Beach Ave., Los Angeles; C. F. Weber & Co., San Francisco.

BOILERS

California Hydraulic Engineering & Supply Co., 70-72 Fremont St., San Francisco.

General Boilers Co., 322 Monadnock Bldg., San Francisco.

Kewanee Water Supply System, Simonds Machinery Co., 117 New Montgomery St., San Francisco.

BOOK BINDERS

Abbott-Brady Printing Corp'n, 460 Fourth St., San Francisco.

H. S. Crocker Co., 565 Market St., San Francisco.

BONDS FOR CONTRACTORS

American Mutual Liability Insurance Co., Balboa Bldg., San Francisco.

Bonding Company of America, Kohl Bldg., San Francisco.

Bankers & Shippers Insurance Co. of New York, Insurance Exchange Bldg., San Francisco.

Globe Indemnity Co., 120 Leidesdorff St., San Francisco.

Fidelity & Casualty Co. of New York, Merchants Exchange Bldg., San Francisco.

John H. Robertson, 621 First National Bank Building, San Francisco.

National Surety Co. of New York, 105' Montgomery St., San Francisco.

BRASS GOODS, CASTINGS, ETC.

H. Mueller Manufacturing Co., 635 Mission St., San Francisco.

BRICK, PRESSED, PAVING, ETC.

California Brick Company, 604 Mission street, San Francisco.

Livermore Fire Brick Works, 604 Mission street, San Francisco.

Los Angeles Pressed Brick Co., Frost Bldg., Los Angeles.

United Materials Co., Crossley Bldg., San Francisco.

Cannon & Co., Sacramento; and 77 O'Farrell street, San Francisco.

BRICK & CEMENT COATING

Armorite and Concreta, manufactured by W. P. Fuller & Co., all principal Coast cities.

The Paraffine Companies, Inc., 34 First St., San Francisco.

R. N. Nason & Co., 151 Potrero Ave., San Francisco.

Wadsworth, Howland & Co., Inc., Boston, Mass., manufacturers of Bay State Brick & Cement Coating.

Hambley & Son, agents, San Francisco and Los Angeles.

BRICK STAINS

Samuel Cabot Mfg. Co., Boston, Mass., agencies in San Francisco, Oakland, Los Angeles, Portland, Tacoma and Spokane.

Armorite and Concreta, manufactured by W. P. Fuller & Co., all principal Coast cities.

BUILDERS' HARDWARE

Joost Bros., agents for Russell & Erwin Hardware, 1053 Market St., San Francisco.

The Stanley Works, New Britain, Conn., represented in San Francisco and Los Angeles by John Rountree & Co.

Palace Hardware Company, Agents Corbin goods, 381 Market St., San Francisco.

Richards-Wilcox Mfg. Co., Aurora; Ewing-Lewis Co., 626 Underwood Bldg., San Francisco.

GRINNELL AUTOMATIC SPRINKLER GRINNELL COMPANY

OF THE PACIFIC

ENGINEERS AND CONTRACTORS
453 Mission Street, San Francisco

VALVES
PIPE and FITTINGS

CHEMICAL FIRE
EXTINGUISHERS
and FIRE ENGINES

An Index to the Advertisements

	Page		Page		Page
Abbott-Brady Printing Corp.	151	Globe Indemnity Co.	150	Pacific Pump & Supply Co.	38
Auderson, V. A.	17	Go-Sign & Letter Co.	145	Pacific Rolling Mills	6
American Art Metal Works	37	Grinnell Co.	7	Palace Hardware Co.	38
American Face Brick Ass'n.	129	Gunn Carle Company	5	Palm Iron Works	6
American Insulex Co.	136	Haines, Jones & Cadbury	131	Palmer & Petersen	142
American La France Fire En- gine Co.	27	Hannah, J. D.	142	Paraffine Companies, Inc.	1
American Mutual Liability Insurance Co.	10	Hauser Window Co.	126	Parker, K. E. Co., Inc.	144
American Mail Chute	28	Haws Sanitary Drinking Fau- cet Co.	138	Petrium Sanitary Sink Co.	141
American Marble & Mosaic Co.	44	Hillard, C. J. Co.	6	Phillips, Chas. T.	145
American Rolling Mill Co.	135	Hobrock, Merrill & Stetson	147	Pitcher Door Hanger	29
American Window Glass Co.	42	Home Mfg. Co.	158	Pittsburg Water Heater Co.	148
Atlas Heating & Ventilating Co.	146	Hoosier Store	36	Plummer, W. A.	138
Atlas Portland Cement Co.	119	Hughson, W. L. Co.	26	Pope & Talbot	15
Bacon, Edward R., Co.	132	Hunt, Robt. W. & Co.	132	Portland Lumber Co.	15
Badt-Falk & Co.	145	Hunter & Hudson	140	Portland Cement Ass'n.	117
Baird-Bailhache Company	34	Ideal Heating & Engineering Co.	146	Portman, Frank	158
Bankers' & Shippers' Ins. Co.	132	Illinois Engineering Co.	146	Prometheus Electric Co.	4
Barrett & Hilp	144	Imp Mfg. Co.	148	Raymond Granite Co.	152
Bartlett, John M.	136	Imperial Waterproofing	28	Reliance-Grant Elevator Equip- ment Co.	22
Bass-Hueter Co.	3rd Cover	James & Drucker	146	Richard Wilcox	5
Beach-Robinson Co.	27	Jarvis, T. P. Mfg. Co.	43	Ringius, John	36
Beckwith, Herbert	145	Johns-Manville Co.	152	Roberts Mfg. Co.	159
Bowser & Co., S. F.	41	Johnson, S. T.	43	Robertson Co., H. H.	11
Breuner, John	136	Johnson Service Co.	11	Robertson, John H.	150
Briminstool Co.	22	Joost Brothers	140	Ruegg Bros.	150
Brown, Arthur	118	Kawneer Mfg. Co.	143	Rucker-Fuller Desk Co.	140
Browne-Langlais Company	155	Kerner Incinerator Co.	42	Ryan, M. E.	155
Builders and Roofers Exchange	140	Kissel, I. R.	142	Safety Electric Co.	154
Bunting Iron Works	43	Knittle-Cashel Co., Inc.	13	Sampson Spot Cord	136
Butte Electrical Equipment Co.	154	Knowles, A.	152	Scott Co.	146
Butte Electric & Mfg. Co.	155	Lannom Bros. Mfg. Co.	158	Schrader Iron Works	152
Cabot, Samuel (Inc.)	41	Lange & Bergstrom	157	Schwabacher-Frey Co.	159
California Artistic Metal and Wire Co.	152	Leiter, E. T. & Son	136	Sloane, W. & J.	4
California Bldg. Material Co.	160	Liberty Electric Co.	155	Simmons, O. M. Co.	12
California Brick Co.	33	Littlefield, R. W.	144	Simonds Machinery Co.	127
California Granite Co.	146	Livermore Fire Brick Works	33	Smith-Booth-Usher Co.	157
California Hydraulic Engineer- ing and Supply Co.	10	Los Angeles Pressed Brick Co.	128	Smith, Jas. F.	144
California Paint Co.	14	MacGruer & Simpson	151	Sommer, I. M.	144
California Plastic Products Co.	137	MacRorie-McLaren Co.	153	Soaneborn, L.	139
California Redwood Ass'n.	153	Magner Bros.	140	Sonnenschein Bros.	27
California Steam and Plumb- ing Supply Co.	137	Mangrum & Otter	159	Soulé, Edward L. Co.	132
Cannon & Co.	24	Marshall & Stearns Co.	141	Spencer Elevator Co.	34
Cement Gun Construction Co.	148	McClellanah Products Co.	148	Spott Electrical Co.	156
Central Electric Co.	148	McCray Refrigerator Co.	28	Standard Metal Mfrs.	130
Central Iron Works	152	McLaughlin, Jas. L.	158	Standard Varnish Works	116
Cobbledick-Kibbe Glass Co.	152	McLeran & Peterson	150	Standard Electric Time Co.	4
Coleman, Alex.	146	McNab, H. N.	145	Standard Fence Co.	145
Collman & Speidel	142	Medusa Cement	23	Stanley Works, The	113
Cook Belting Co.	38	Meese & Gottfried	118	Stelform Contracting Co.	144
Cowell Lime & Cement Co.	143	Millmen's Audit Bureau	124	St. Francis Hotel	127
Crane Co.	153	Moline Heat	16	Stockholm, Chas. & Son	136
Crocker, H. S. Co.	121	Montague Range & Furnace Co.	18	Strable Hardwood Co.	125
Davis, R. J.	9	Monson Bros.	142	Sunset Lumber Company	15
Del Favero and Rasori	142	Mortenson Construction Co.	152	Tay Company, George H.	31
Del Monte Properties Co.	20	Mott Co. of Calif.	18	Taylor Galleries	27
Dieckhoff Steel Products Co.	44	Mueller Mfg. Co.	18	Tittle, H. S.	155
Dietzmann Hardwood Co.	12	Mullen Mfg. Co.	158	Torney Co.	140
Direct Line Telephone Co.	159	Musket Co., W. E.	30	Trost, Robt.	142
Dolan Wrecking & Construc- tion Co.	158	Musto Sons Keenan Co.	13	Truscoon Steel Co.	26
Drendell Elec. & Mfg. Co.	154	Myers & Schwartz	32	Uhl Bros.	38
Dudfield Lumber Co.	158	Nason, R. N. & Co.	9	Unit Construction Co.	142
Duncan, W. C.	144	Nathan, Dohrmann Co.	156	United Electric Co.	149
Dunham, C. A. Co.	31	National Magnesite Co.	151	United Materials Co.	128
Electric Outlet Co.	3	National Mill & Lumber Co.	29	U. S. Metal Products Co.	22
Elevator Supplies Co.	150	National Surety Co.	150	U. S. Steel Products Co.	40
Elery Arms Co.	140	National Terra Cotta Society	115	Van Fleet-Freear Co.	143
Fess System Co.	43	National Valve Co.	130	Vermont Marble Co.	4
Fidelity & Casualty Co. of N.Y.	150	National Window Shade Co.	120	Vukicevich & Bagge	144
Fink & Schindler Co., The	158	Nelson, James A.	155	Wadsworth, Howland & Co., Inc	126
First National Bank	118	Ne Page, McKenny Co.	155	Walter, D. N. & E. Co.	145
Flagg, Edwin H., Scenic Co.	150	Newbery Electric Co.	155	Wayne Oil Tank & Pump Co.	29
Forderer Cornice Wks.	134	New York Belting and Pack- ing Co.	37	Weber, C. F. & Co.	153
Freeman Art Shop	30	Norris Co., L. A.	28	Wentworth, F. W.	158
Fuller & Goepf	34	Oak Flooring Mfrs' Ass'n.	21	West Coast Porcelain Co.	148
Fuller, W. P. Co.	19	Ocean Shore Iron Works	138	Back Cover	
Garfield Company	157	Old Mission Portland Cement Co.	35	Western Blind & Screen Co.	39
Garrett, Young & Co.	20	Otis Elevator Co.	160	Western Safety Mfg. Co.	154
General Boilers Co.	24	Pacific Coast Steel Company	151	Western Iron Works	6
General Machinery & Supply Co.	2	Pacific Electric Clock Co.	2	Western Pipe and Steel Co.	147
Gilley-Schmid Co.	140	Pacific Fire Extinguisher Co.	143	White Bros.	112
Gladling, McBean & Co.	138	Pacific Mfg. Co.	15	Wilson, J. G., Corp.	133
Globe Electric Works	155	Pacific Materials Co.	23-41-44	Wilson, W. F., Co.	146
		Pacific Painting and Roofing Co.	14	Witt, G. E. Co.	44
		Pacific Plumbing Fixtures, 2d Cover		Zelinsky, D. & Sons	145
		Pacific Porcelain Ware Co., 2d Cover			

Nason's Opaque Flat Finish

A Flat Washable Oil Paint, made in soft Kalsomine tints—a practical article for Walls, Ceilings, Etc. Agency for Tamm & Nolan Company's High Grade VARNISHES and FINISHES, made on the Pacific Coast to stand our climatic conditions.

R. N. NASON & CO. Paint Makers
151 Potrero Ave.—436 Market St., San Francisco--Portland-Seattle-Oregon

ARCHITECTS' SPECIFICATION INDEX—Continued

- BUILDING MATERIALS, SUPPLIES, ETC.**
California Brick Company, 604 Mission street, San Francisco.
Pacific Materials Co., Underwood Bldg., San Francisco.
Waterhouse-Wilcox Co., 523 Market St., San Francisco.
Johns-Manville Company, Post and Mason Sts., San Francisco.
- CABINET MAKERS**
Home Manufacturing Company, 543 Brannan St., San Francisco.
Fink & Schindler Co., 218 13th St., San Francisco.
Mullen Manufacturing Company, 64 Rausch St., San Francisco.
Lannon Bros. Mfg. Co., 5th and Magnolia sts., Oakland.
Pacific Mfg. Co., San Francisco, Los Angeles and Oakland.
Frank Portman, 1618 Mission St., San Francisco.
- CARPETS**
W. & J. Sloane, 216-228 Sutter St., San Francisco.
John Breuner Co., 281 Geary St., San Francisco.
D. N. & E. Walter, Mission near Second street, San Francisco.
- CASEMENT WINDOW HARDWARE**
Richards-Wilcox Mfg. Co., Aurora, Ill., and Underwood Bldg., San Francisco.
- CEMENT**
Atlas Portland Cement Co., all principal cities.
Mt. Diablo, sold by Henry Cowell Lime & Cement Co., 2 Market St., San Francisco.
Medusa White Portland Cement, manufactured by Sandusky Cement Co., represented in San Francisco by Pacific Building Materials Co., Underwood Bldg., San Francisco.
Old Mission Portland Cement Co., Mills Building San Francisco.
- CEMENT EXTERIOR WATERPROOF PAINT**
Armorite, sold by W. P. Fuller & Co., all principal Coast cities.
Bay State Brick and Cement Coating, manufactured by Wadsworth, Howland Co., Boston, Mass. James Hampley & Son, Distributors, San Francisco and Los Angeles.
Hill, Hubbell & Company, No. 1 Drumm St., San Francisco.
Imperial Waterproofing, manufactured by Brooks & Doerr, Reed Baxter, agent, Merchants National Bank Bldg., San Francisco.
Medusa White Portland Cement, manufactured by Sandusky Cement Co., represented in San Francisco by Pacific Materials Co., 525 Market St., San Francisco.
- CEMENT GUN**
Cement Gun Construction Company of California, 701 Balboa Bldg., San Francisco.
- CEMENT TESTS—CHEMICAL ENGINEERS**
Robert W. Hunt & Co., 251 Kearny St., San Francisco.
- CLAY PRODUCTS**
California Brick Company, 604 Mission street, San Francisco.
Cannon & Co., Sacramento; and Chronicle Bldg., San Francisco.
Gladding, McBean & Co., Crocker Bldg., San Francisco.
- Los Angeles Pressed Brick Co., Frost Bldg., Los Angeles.
United Materials Co., Sharon Bldg., San Francisco.
- CLOCKS—ELECTRIC TIME**
Pacific Electric Clock Co., 516 Wells-Fargo Bldg., San Francisco.
Standard Electric Time Co., 461 Market St., San Francisco.
- COLD STORAGE PLANTS**
H. W. Johns-Manville Co., Post and Mason Sts., San Francisco.
T. P. Jarvis Crude Oil Burning Co., 275 Connecticut St., San Francisco.
- COMPRESSED AIR CLEANERS**
United Electric Co., Canton, O., mfr. of Tuec Cleaner, sold by San Francisco Compressed Air Cleaning Co., Sutter and Stockton Sts., San Francisco.
George H. Tay Company, Mission and Second Sts., San Francisco; 10th and Harrison Sts., Oakland.
- CONCRETE CONSTRUCTION**
Barrett & Hilp, Sharon Bldg., San Francisco.
Clinton Construction Co., 140 Townsend street, San Francisco.
K. E. Parker Co., Inc., Clunie Bldg., San Francisco.
Palmer & Petersen, Monadnock Bldg., San Francisco.
J. M. Sommer, 401 Balboa Bldg., San Francisco.
Steelform Contracting Company, 681 Market St., San Francisco.
- CONCRETE HARDENER**
Gunn, Carle & Co., Inc., 444 Market street, San Francisco.
- CONCRETE MIXERS**
Foote and Jaeger mixers sold by Edward R. Bacon Co., 51 Minna St., San Francisco, also Los Angeles.
Ransome mixers sold by the Garfield Co., Hearst Bldg., San Francisco.
Smith-Booth-Usher Co., San Francisco and Los Angeles.
- CONCRETE REINFORCEMENT**
Edw. L. Soule Co., Rialto bldg., San Francisco.
United States Steel Products Co., San Francisco, Los Angeles, Portland and Seattle.
Twisted Bars. Sold by Gunn, Carle & Co., Inc., 444 Market St., San Francisco.
Clinton Welded Wire Fabric, L. A. Norris Co., 140 Townsend St., San Francisco.
Pacific Coast Steel Company, Rialto Bldg., San Francisco.
Triangle Mesh Fabric. Sales agents, Pacific Materials Co., 525 Market St., San Francisco.
Truscon Steel Co., 527 Tenth St., San Francisco.
Badt-Falk Co., Call-Post Bldg., San Francisco.
- CONDUITS**
Garnett Young & Co., 612 Howard St., San Francisco.
- CONTRACTORS, GENERAL**
Barrett & Hilp, Sharon Bldg., San Francisco.
K. E. Parker Co., Inc., Clunie Bldg., San Francisco.
R. W. Littlefield, 357 12th St., Oakland.
Unit Construction Co., Phelan Bldg., San Francisco.
J. D. Hannah, 142 Sansome St., San Francisco.

R. J. Davis

District Sales Agent

Century

**A. C. Motors
and Fans**

Complete stocks carried at: 171-173 Second St., San Francisco; 906 So. Hope St., Los Angeles

We have returned to our policy-holders annually for 33 years never less than 30% of the premium as a dividend. Dividends declared during 1919, \$2,017,893.

AMERICAN MUTUAL LIABILITY INSURANCE CO. OF BOSTON

Assets \$8,654,667

Surplus \$1,417,173

WORKMEN'S COMPENSATION, AUTOMOBILE, TEAMS AND PUBLIC LIABILITY INSURANCE

SAN FRANCISCO BRANCH OFFICE

1816 Balboa Building. Telephone Kearny 3202

N. F. Hesseltnie, California Manager.

C. H. Gray, Assistant Manager.

ARCHITECTS' SPECIFICATION INDEX—Continued

CONTRACTORS, GENERAL—Continued

John M. Bartlett, 357 Twelfth St., Oakland.
E. T. Leiter & Son, Call-Post Bldg., San Francisco.
Chas. Stockholm & Son, Monadnock Bldg., San Francisco.
Herbert Beckwith, 323 Newton Ave., Oakland.
Collman & Speidel, 546 Monadnock Bldg., San Francisco.
Clinton Construction Company, 140 Townsend St., San Francisco.
Monson Bros., 1907 Bryant St., San Francisco.
W. C. Duncan & Co., 526 Sharon Bldg., San Francisco.
A. Knowles, Call-Post Bldg., San Francisco.
T. B. Goodwin, 180 Jessie St., San Francisco.
Lange & Bergstrom, Sharon Bldg., San Francisco.
McLeran & Peterson, Hearst Bldg., San Francisco.
Robert Trost, 26th and Howard Sts., San Francisco.
I. M. Sommer, 401 Balboa Bldg., San Francisco.
Del Favero & Rasori, 180 Jessie St., San Francisco.
Jas. L. McLaughlin, 251 Kearny street, San Francisco.

CONTRACTORS' EQUIPMENT

Edward R. Bacon Co., 51 Minna St., San Francisco, and Los Angeles.
Garfield & Co., Hearst Bldg., San Francisco.
Smith, Booth-Usher Co., 60 Fremont St., San Francisco; 228 Central Ave., Los Angeles.

CONTRACTORS' INSURANCE

Bankers & Shippers Insurance Co. of New York, Insurance Exchange Bldg., San Francisco.

CONVEYING MACHINERY

Meese & Gottfried, San Francisco, Los Angeles, Portland and Seattle.

CORK TILE, INSULATION, ETC.

Van Fleet-Freear Co., Sharon Bldg., San Francisco.

CRUSHED ROCK

Coast Rock & Gravel Co., Call-Post Bldg., San Francisco.

DAMP-PROOFING COMPOUND

Armorite Damp Resisting Paint, made by W. P. Fuller & Co., San Francisco.
Gunn, Carle & Co., Inc., 444 First street, San Francisco.
Hill, Hubbell & Company, No. 1 Drumm St., San Francisco.
Imperial Waterproofing, mfrd. by Brooks & Doerr, Reed Baxter, agent, Merchants National Bank Bldg., San Francisco.
"Pabco" Damp-Proofing Compound, sold by Paraffine Co., 34 First St., San Francisco.

DOOR HANGERS

Pitcher Hanger, sold by National Lumber Co., 326 Market St., San Francisco.
Reliance Hanger, sold by Waterhouse-Wilcox Co., San Francisco; D. F. Fryer & Co., B. V. Collins, Los Angeles, and Columbia Wire & Iron Works, Portland, Oregon.
Stanley Works, New Britain, Conn. John Rountree, agent, Monadnock Bldg., San Francisco.
Richards-Wilcox Mfg. Co., Underwood Bldg., San Francisco.

DRINKING FOUNTAINS

Haws Sanitary Drinking Faucet Co., 1808 Harmon St. Berkeley, and C. F. Weber & Co., San Francisco and Los Angeles.

Crane Company, San Francisco, Oakland, and Los Angeles.

Pacific Porcelain Ware Co., 67 New Montgomery St., San Francisco.

George H. Tay Company, Mission and Second Sts., San Francisco; 10th and Harrison Sts., Oakland.

Haines, Jones & Cadbury Co., 857 Folsom St., San Francisco.

DUMB WAITERS

Spencer Elevator Company, 166 7th St., San Francisco.

M. E. Hammond, Pacific Bldg., San Francisco.

ELECTRICAL CONTRACTORS

Butte Electrical Equipment Company, 530 Folsom St., San Francisco.

Butte Electric & Manufacturing Co., 534 Folsom St., San Francisco.

Brown-Langlais Electrical Construction Co., 213 Minna St., San Francisco.

Central Electric Company, 185 Stevenson street, San Francisco.

NePage, McKenny Co., 589 Howard St., San Francisco.

Liberty Electric Company, 479 Sutter St., San Francisco.

Newbery Electrical Co., 413 Lick Bldg., San Francisco.

Pacific Fire Extinguisher Co., 424 Howard St., San Francisco.

Globe Electric Works, 1959 Mission St., San Francisco.

M. E. Ryan, Redwood City, Calif.

H. S. Tittle, 766 Folsom St., San Francisco.

Spott Electrical Co., Sixteenth and Clay Sts., Oakland.

ELECTRIC PLATE WARMER

The Prometheus Electric Plate Warmer for residences, clubs, hotels, etc. Sold by M. E. Hammond, Pacific Bldg., San Francisco.

ELECTRICAL SUPPLIES AND EQUIPMENT

Garnett Young & Co., 612 Howard St., San Francisco.

Butte Electrical Equipment Co., 530 Folsom St., San Francisco.

Electric Outlet Co., Inc., 119 West 40th St., New York.

Safety Electric Company, 56-65 Columbia Square, San Francisco.

Drendell Electrical & Mfg. Co., 1345 Howard St., San Francisco.

R. J. Davis, District Sales Agent, Century A. C. Motors and Fans, 171 Second St., San Francisco.

Western Electric Safety Mfg. Co., Inc., 247 Minna street, San Francisco.

ELEVATORS

Otis Elevator Company, Stockton and North Point, San Francisco.

Spencer Elevator Company, 166 7th St., San Francisco.

ELEVATOR EQUIPMENT

Elevator Supplies Company, Inc., 186 Fifth St., San Francisco.

ENGINEERS—CONSULTING, ELECTRICAL, MECHANICAL

Chas. T. Phillips, Pacific Bldg., San Francisco.

Hunter & Hudson, Rialto Bldg., San Francisco.

ELEVATOR DOOR HARDWARE

Richards-Wilcox Mfg. Co., Underwood Bldg., San Francisco.

**KEWANEE
GARBAGE BURNERS
AND
BOILERS**

**YEOMANS
BILGE PUMPS
EJECTORS
HOUSE PUMPS**

**OVERHEAD
CARRYING
SYSTEMS**

CALIFORNIA HYDRAULIC ENGINEERING & SUPPLY CO., 80 Fremont St., S. F.



TEMPERATURE REGULATION

JOHNSON SERVICE COMPANY

(OF MILWAUKEE — ESTABLISHED 1885)

Manufacturers and Installers of **JOHNSON Heat Humidity CONTROL**

For schools, residences, hospitals, banks, public buildings, also canneries and all kinds of industrial plants—Hot water tank regulators, air and water reducing valves.

Rialto Bldg, SAN FRANCISCO 605 Van Nuys Bldg., LOS ANGELES



ARCHITECTS' SPECIFICATION INDEX—Continued

FANS AND BLOWERS

Ideal Heating & Engineering Co., 192 Erie St., San Francisco.
John Ringins Co., Inc., 1267 Folsom street, San Francisco.

FENCES—WIRE

Standard Fence Construction Co., 245 Market St., San Francisco, and 310 12th St., Oakland.

FILLING STATION EQUIPMENT

S. F. Bowser & Co., Inc., 612 Howard St., San Francisco.
Wayne Oil Tank & Pump Co., 631 Howard St., San Francisco, 830 S. Los Angeles St., Los Angeles.

FIRE BRICK

Livermore Fire Brick Works, 604 Mission street, San Francisco.

FIRE ESCAPES

Palm Iron & Bridge Works, Sacramento.
Western Iron Works, 141 Beale St., San Francisco.
Golden Gate Iron Works, 1541 Howard St., San Francisco.

FIRE EXTINGUISHERS

American La France Fire Engine Co., Inc., 151 New Montgomery St., San Francisco; Los Angeles and Portland.

FIRE INSURANCE

Bankers & Shippers Insurance Co., Insurance Exchange Bldg., San Francisco.

FIRE PROOFING

American Insulex Company, Berkeley Bank Bldg., Berkeley.

FIRE-PROOF DOORS

Forrester Cornice Works, 269 Potrero avenue, San Francisco.
U. S. Metal Products Co., 330 10th street, San Francisco.
Fire Protection Products Co., 3117 20th street, San Francisco.

FIRE SPRINKLERS—AUTOMATIC

Grinnell Company, 453 Mission St., San Francisco.
Pacific Fire Extinguisher Co., 424 Howard St., San Francisco.

FIRE RETARDING PAINT

The Paraffine Companies, Inc., 34 First St., San Francisco.

FIXTURES—BANK, OFFICE, STORE, ETC.

Home Manufacturing Company, 543 Brannan St., San Francisco.
The Fink & Schindler Co., 218 13th St., San Francisco.
Mullen Manufacturing Co., 64 Rausch St., San Francisco.

C. F. Weber & Co., 985 Market St., San Francisco, and 210 N. Main St., Los Angeles, Cal.

FLOOR TILE

Mangrum & Otter, 827 Mission St., San Francisco.

FLOOR VARNISH

Bass-Hueter and San Francisco Pioneer Varnish Works, 816 Mission St., San Francisco.
Fifteen for Floors, made by W. P. Fuller & Co., San Francisco.
Standard Varnish Works, Chicago, New York and San Francisco.
R. N. Nason & Co., San Francisco and Los Angeles.

FLOORS—HARDWOOD

Oak Flooring Manufacturers' Association of the United States, Ashland Block, Chicago, Ill.
Parrott & Co., 320 California St., San Francisco.
White Bros., Fifth and Brannan Sts., San Francisco.
Strable Hardwood Company, 511 First street, Oakland.

FLOORS—MASTIC

Hill, Hubbell & Company, No. 1 Drumm St., San Francisco.

FLOORS—DUST PROOF CEMENT

L. Sonneborn Co., United Materials Co., San Francisco agents.

FLUMES

California Corrugated Culvert Co., West Berkeley, Cal.

FLUSH VALVES

National Valve Company, 23-25 Minna St., San Francisco.

FRUIT DRYING MACHINERY

Ideal Heating & Engineering Co., 192 Erie St., San Francisco.
Jas. A. Nelson, 517 Sixth St., San Francisco.

FUEL OIL SYSTEMS

S. T. Johnson Co., 1337 Mission St., San Francisco.
S. F. Bowser & Co., Inc., 612 Howard St., San Francisco.

Wayne Oil Tank & Pump Co., 631 Howard St., San Francisco.

FURNACES—WARM AIR

Mangrum & Otter, 827 Mission St., San Francisco.
Montagne Range and Furnace Co., 826 Mission St., San Francisco.

FURNITURE—BUILT-IN

Hoosier Kitchen Cabinet Store, Pacific Bldg., San Francisco.

FURNITURE—SCHOOL, CHURCH, OFFICE, HOUSE, ETC.

Home Manufacturing Company, 543 Brannan St., San Francisco.
C. F. Weber & Co., 985 Market St., San Francisco.
Rucker-Fuller Desk Co., 677 Mission St., San Francisco.
F. W. Wentworth & Co., 539 Market St., San Francisco.
W. & J. Sloane, 216-228 Sutter St., San Francisco.

GARAGE HARDWARE

The Stanley Works, New Britain, Conn., represented in San Francisco, Los Angeles, Seattle by John T. Rowntree, Inc.
Richards-Wilcox Mfg. Co., Aurora, Ill., and Underwood Bldg., San Francisco.

GARBAGE CHUTES AND INCINERATORS

Kerner Incinerator Co., 77 O'Farrell St., San Francisco.

California Hydraulic Engineering & Supply Co., 70-72 Fremont St., San Francisco.

GAS STEAM RADIATORS—FUMELESS, ETC.

Clow Gas Steam Radiators, F. A. Hamilton, Agent, 101 Rialto Bldg., San Francisco.

ROBERTSON PROCESS METAL FOR ROOFING AND SIDING

HH
BUILDING
PRODUCTS

ROBERTSON CO
BUILDING
PRODUCTS

FORMERLY ASBESTOS PROTECTED METAL COMPANY

Hobart Building, San Francisco

Phone Garfield 522

DIECKMANN HARDWOOD COMPANY

Office, Mill, Yards, and Dry Kilns
BEACH AND TAYLOR STS.
 SAN FRANCISCO, CAL.
 PHONE FRANKLIN 2302

**Foreign & Domestic
 CABINET WOODS**

ARCHITECTS' SPECIFICATION INDEX—Continued

- GAS STEAM RADIATORS, ETC.**—Continued.
 Ra-Do Fumeless Gas Radiators, manufactured and sold by Baird-Bailhache Co., 478 Sutter St., San Francisco.
- GLASS**
 American Window Glass Co., represented by L. H. Butcher Co., 862 Mission st., San Francisco.
 Cobbletick-Kibbe Glass Co., 175 Jessie St., San Francisco.
 Fuller & Goepf, 32 Page St., San Francisco.
 W. P. Fuller & Company, all principal Coast cities.
- GRADING, WRECKING, ETC.**
 Dolan Wrecking & Construction Co., 1607 Market St., San Francisco.
- GRANITE**
 California Granite Co., Gen. Contractors' Ass'n, San Francisco.
 Raymond Granite Co., Potrero Ave. and Division St., San Francisco.
- GRAVEL AND SAND**
 Coast Rock & Gravel Co., Call-Post Bldg., San Francisco.
 Del Monte White Sand, sold by Del Monte Properties Co., Crocker Bldg., San Francisco.
- GYMNASIUM EQUIPMENT**
 Ellery Arms Co., 583 Market St., San Francisco.
 A. G. Spalding & Bros., 158 Geary St., San Francisco.
- HARDWALL PLASTER**
 Henry Cowell Lime & Cement Co., San Francisco.
- HARDWARE**
 Joost Bros., agents for Russell & Erwin hardware, 1053 Market St., San Francisco.
 The Stanley Works, New Britain, Conn.; Coast sales offices, San Francisco, Los Angeles, and Seattle, Wash.
 Corbin hardware, sold by Palace Hardware Co., 581 Market St., San Francisco.
 Richards-Wilcox Mfg. Co., Aurora, Ill., Ewing-Lewis Co., 626 Underwood Bldg., San Francisco.
- HARDWOOD LUMBER—FLOORING, ETC.**
 Dieckmann Hardwood Company, Beach and Taylor Sts., San Francisco. (See advertisement above.)
 H. N. McNab, 2307 17th Ave., Oakland.
 Parrott & Co., 320 California St., San Francisco.
 White Bros., cor. Fifth and Brannan Sts., San Francisco.
 Strable Hardwood Company, First street, near Broadway, Oakland.
- HEATERS—AUTOMATIC—GAS**
 Pittsburg Water Healer Co., 478 Sutter St., San Francisco.
 George H. Tay Company, Mission and Second Sts., San Francisco; 10th and Harrison Sts., Oakland.
 Ra-Do Fumeless Gas Heater, sold by Baird-Bailhache Company, 478 Sutter St., San Francisco.
- HEATING AND VENTILATING CONTRACTORS, EQUIPMENT, ETC.**
 Alex Coleman, 706 Ellis St., San Francisco.
- C. A. Dunham Co., Sheldon Building, San Francisco.
 Gilley-Schmid Company, 198 Otis St., San Francisco.
 Hateley & Hateley, Mitau Bldg., Sacramento.
 Knittle-Cashel Co., Inc., 1820 Ellis St., San Francisco.
 General Boilers Co., 332 Monadnock Bldg., San Francisco.
 Mangrum & Otter, 827-831 Mission St., San Francisco.
 Moline Heat, Hobart Bldg., San Francisco.
 James & Drucker, 450 Hayes St., San Francisco.
 James A. Nelson, 517 Sixth St., San Francisco.
 Ideal Heating & Engineering Co., 192 Erie St., San Francisco.
 Illinois Engineering Co., 563 Pacific Bldg., San Francisco.
 William F. Wilson Co., 328 Mason St., San Francisco.
 Pacific Fire Extinguisher Co., 424 Howard St., San Francisco.
 Scott Company, 243 Minna St., San Francisco.
 Mechanical Engineering & Supply Co., 908 7th St., Sacramento.
 George H. Tay Company, Mission and Second Sts., San Francisco; 10th and Harrison Sts., Oakland.
 O. M. Simmons Co., 115 Mission St., San Francisco.
- HOLLOW TILE BLOCKS**
 Cannon & Co., plant at Sacramento; office in Chronicle Bldg., San Francisco.
 Gladding, McBean & Co., San Francisco, Los Angeles, Oakland and Sacramento.
 Los Angeles Pressed Brick Co., Frost Bldg., Los Angeles.
 California Brick Company, 604 Mission street, San Francisco.
 Livermore Fire Brick Works, 604 Mission street, San Francisco.
- HOSPITAL FIXTURES**
 Mott Company of California, 553 Mission St., San Francisco.
 George H. Tay Company, Mission and Second Sts., San Francisco; 10th and Harrison Sts., Oakland.
- HOSPITAL SIGNAL SYSTEM**
 Chicago Signal Co., represented by Garnett, Young & Co., 612 Howard St., San Francisco.
- HOTELS**
 St. Francis Hotel, Powell, Geary and Post Sts., San Francisco.
- INGOT IRON**
 "Armo" brand, manufactured by American Rolling Mill Company, Middletown, Ohio, and 10th and Bryant streets, San Francisco.
- INSPECTIONS AND TESTS**
 Robert W. Hunt & Co., 251 Kearny St., San Francisco.
- INSULATION**
 American Insulux Company, Berkeley Bank building, Berkeley.
- INCINERATORS**
 Kerner Incinerator Co., 77 O'Farrell St., San Francisco.

"The
 Perfect
 Automatic
 Valve"

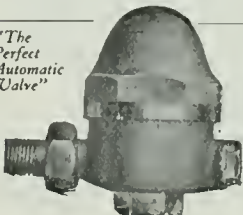

Haines Heating Systems

ASSURE

Heating Satisfaction

O. M. SIMMONS CO.

115 Mission St., San Francisco
 Phone: Douglas 5497

CLARENCE E. MUSTO, Pres. JOSEPH B. KEENAN, Vice-Pres. GUIDO J. MUSTO, Sec'y & Treas.

JOSEPH MUSTO SONS-KEENAN CO.

Phone Franklin
—6365—

MARBLE

OFFICE AND MILLS:
535-565 North Point St.,
SAN FRANCISCO, CAL.

ARCHITECTS' SPECIFICATION INDEX—Continued

INTERIOR DECORATORS

Beach-Robinson Co., 239 Geary St., San Francisco.

Arthur Brown, 212 Foxcroft Bldg., San Francisco.

John Breuner Co., 281 Geary St., San Francisco.
Sonnenschein Bros., 470 Sutter St., San Francisco.

The Torney Co., 1042 Larkin St., San Francisco.
Taylor Galleries, 1818 Harrison street, Oakland and San Francisco.

Freeman Art Shop, 386 Sutter St., San Francisco.

W. & J. Sloane, 216 Sutter St., San Francisco.

KITCHEN CABINETS

Hoosier Kitchen Cabinet Store (O. K. Brown, Mgr.), Pacific Bldg., San Francisco.

LAMP POSTS, ELECTROLIERS, ETC.

J. L. Mott Iron Works, 553 Mission St., San Francisco.

LANDSCAPE GARDENERS

MacRorie-McLaren Co., 141 Powell St., San Francisco.

LATHING AND PLASTERING

MacGruer & Simpson, Call-Post Bldg., San Francisco.

A. Knowles, Call-Post Bldg., San Francisco.
Jas. F. Smith, 273 Minna St., San Francisco.

LATHING MATERIAL

Pacific Materials Co., 525 Market St., San Francisco.

Truscon Steel Co., Tenth St., near Bryant, San Francisco.

LIGHT, HEAT AND POWER

Great Western Power Company, Stockton St., near Sutter, San Francisco.

LIGHTING FIXTURES

Roberts Mfg. Co., 663 Mission St., San Francisco.
Perfeclite Manufacturing Co., Seattle, Wash.;
San Francisco Representatives, Myers & Schwartz,
75 New Montgomery street, San Francisco;
1119 S. Los Angeles street, Los Angeles.

LIME

Henry Cowell Lime & Cement Co., 2 Market St., San Francisco.

LINOLEUM

D. N. & E. Walter & Co., 562 Mission St., San Francisco.

The Paraffine Companies, factory in Oakland;
office, 34 First St., near Market, San Francisco.

W. & J. Sloane, 216-228 Sutter St., San Francisco.

LUBRICATING OIL STORAGE TANKS AND PUMPS

S. F. Bowser & Co., Inc., 612 Howard St., San Francisco

LUMBER

California Redwood Association, 216 Pine St., San Francisco.

Dudfield Lumber Co., Palo Alto, Cal.
Hart-Wood Lumber Co., Fifth and Berry Sts., San Francisco.

Pacific Manufacturing Company, San Francisco, Oakland and Santa Clara.

Pope & Talbot, foot of Third St., San Francisco.

Portland Lumber Co., 16 California St., San Francisco.

Sunset Lumber Company, First and Oak Sts., Oakland.

MAIL CHUTES

American Mailing Device Corp., represented on Pacific Coast by Waterhouse-Wilcox Co., 523 Market St., San Francisco.

MANTELS

Mangrum & Otter, 827-831 Mission St., San Francisco.

California Brick Company, 604 Mission street, San Francisco.

MANUAL TRAINING EQUIPMENT

Richards-Wilcox Mfg. Co., Ewing-Lewis Co., 626 Underwood Bldg., San Francisco.

Smith-Booth-Usher Co., San Francisco and Los Angeles.

MARBLE

American Marble and Mosaic Co., 25 Columbus Square, San Francisco.

Joseph Musto Sons, Keenan Co., 535 N. Point St., San Francisco.

Vermont Marble Co., Coast branches, San Francisco, Portland and Tacoma.

METAL DOORS AND WINDOWS

Fire Protection Products Co., 3117 20th St., San Francisco.

Waterhouse-Wilcox Co., Inc., 523 Market St., San Francisco.

U. S. Metal Products Co., 330 Tenth St., San Francisco.

METAL FURNITURE

Forreder Cornice Works, 269 Potrero avenue, San Francisco.

Forreder Cornice Works, 269 Potrero avenue, San Francisco.

MILL WORK

Dudfield Lumber Co., Palo Alto, Cal.
Pacific Manufacturing Company, San Francisco, Oakland and Santa Clara.

National Mill and Lumber Co., San Francisco and Oakland.

The Fink & Schindler Co., 218 13th St., San Francisco.

Frank Portman, 1619-20 Mission St., San Francisco.

Lannom Bros. Mfg. Co., 5th and Magnolia sts., Oakland.

MOTORS AND FANS

R. J. Davis, Dist. Sales Agent Century Motors and Fans, 171 Second St., San Francisco.

OIL BURNERS

Bunting Iron Works, 1215 First Nat. Bank bldg., San Francisco.

Fess System Co., 220 Natoma St., San Francisco.

S. T. Johnson Co., 1337 Mission St., San Francisco.

T. P. Jarvis Manufacturing Co., 275 Connecticut St., San Francisco.

W. S. Ray Mfg. Co., 29 Spear St., San Francisco.

G. E. Witt Co., 862 Howard St., San Francisco.

OIL STORAGE AND DISTRIBUTING STATIONS

S. F. Bowser & Co., Inc., 612 Howard St., San Francisco.

S. T. Johnson Co., 1337 Mission St., San Francisco.

KNITTLE-CASHEL CO., Inc.

HEATING CONTRACTORS

STEAM HEATING
HOT WATER HEATING

VENTILATING
POWER PLANTS

GENERAL PIPE WORK
REPAIRING

1820-22 Ellis Street, San Francisco

Phone West 964



On Your Best Work Specify

CAL-PA-CO DAMPSTOP (Outside) WASHABLE WALL (Inside)

FOR CONCRETE BUILDINGS.

Everything Reliable in PAINT and VARNISH

CALIFORNIA PAINT COMPANY, OAKLAND, CALIF., U. S. A.
MANUFACTURERS SINCE 1865 SAN FRANCISCO OFFICE, MONADNOCK BUILDING

ARCHITECTS' SPECIFICATION INDEX—Continued

- Wayne Oil Tank & Pump Co., 631 Howard St., San Francisco; 830 S. Los Angeles St., Los Angeles.
- OFFICE EQUIPMENT**
C. F. Weber Co., 985 Market St., San Francisco.
Rucker-Fuller Co., 677 Mission St., San Francisco.
F. W. Wentworth & Co., 539 Market St., San Francisco.
- ORNAMENTAL IRON AND BRONZE.**
California Artistic Metal and Wire Co., 349 Seventh St., San Francisco.
Palm Iron & Bridge Works, Sacramento.
C. J. Hillard Company, Inc., 19th and Minnesota Sts., San Francisco.
Schrader Iron Works, Inc., 1247 Harrison St., San Francisco.
- OVERHEAD CARRYING SYSTEMS**
California Hydraulic Engineering & Supply Co., 70-72 Fremont St., San Francisco.
Richards-Wilcox Mfg. Co., Aurora, Ill., and Underwood Bldg., San Francisco.
- PAINT FOR STEEL STRUCTURES, BRIDGES, ETC.**
The Paraffine Companies, Inc., 34 First St., San Francisco.
Premier Graphite Paint and Pioneer Brand Red Lead, made by W. P. Fuller & Co., San Francisco.
Hill, Hubbell & Company, No. 1 Drumm St., San Francisco.
Wadsworth, Howland Co., makers of Bay State Brick and Cement Coating, Boston, Mass.
Hambley & Son, Distributors in San Francisco and Los Angeles.
- PAINTING, TINTING, ETC.**
I. R. Kissel, 1747 Sacramento St., San Francisco.
D. Zelinsky & Sons, San Francisco and Los Angeles.
The Tormey Co., 681 Geary St., San Francisco.
Fick Bros., 475 Haight St., San Francisco.
Pacific Painting and Roofing Co., Pacific building, San Francisco; and 388 12th street Oakland.
- PAINTS, OILS, ETC.**
California Paint Company (see advertisement above).
Magner Bros., 414-424 Ninth St., San Francisco.
Bass-Hueter Paint Co., Mission, near Fourth St., San Francisco and all principal coast cities.
R. N. Nason & Company, San Francisco, Los Angeles, Portland and Seattle.
Ronfle Company, Pacific building, San Francisco; and 388 12th street, Oakland.
W. P. Fuller & Co., all principal Coast cities.
"Satinette," Standard Varnish Works, 55 Stevenson St., San Francisco.
Palace Hardware Co., 581 Market St., San Francisco.
- PANELS AND VENEER**
White Bros., Fifth and Brannan Sts., San Francisco.
- PARTITIONS—FOLDING AND ROLLING**
J. G. Wilson Corporation, 600 Metropolitan Bldg., Los Angeles; Waterhouse-Wilcox Co., Underwood Bldg., San Francisco.
- PENCILS**
Eberhard Faber, Monadnock Bldg., San Francisco.
- PIPE—STEEL AND WROUGHT IRON**
Western Pipe & Steel Co., 444 Market St., San Francisco; 1758 N. Broadway, Los Angeles.
George H. Tay Company, Mission and Second Sts., San Francisco; 10th and Harrison Sts., Oakland.
- PLA GROUND EQUIPMENT**
A. G. Spalding & Bros., 158 Geary St., San Francisco.
- PLUMBING CONTRACTORS**
Alex Coleman, 706 Ellis St., San Francisco.
Gilley-Schmid Company, 198 Otis street, San Francisco.
Hateley & Hateley, Mitau Bldg., Sacramento.
Scott Co., Inc., 243 Minna St., San Francisco.
Wm. F. Wilson Co., 328 Mason St., San Francisco.
- PLUMBING FIXTURES, MATERIALS, ETC.**
All-In-One Company, Ochsner bldg., Sacramento.
California Steam & Plumbing Supply Co., 671 Fifth St., San Francisco.
Crane Co., San Francisco, Oakland, Los Angeles.
Gilley-Schmid Company, 198 Otis St., San Francisco.
Haines, Jones & Cadbury Co., 857 Folsom St., San Francisco.
H. Mueller Manufacturing Company, 635 Mission St., San Francisco.
Holbrook, Merrill & Stetson, 64 Sutter St., San Francisco.
J. L. Mott Iron Works, D. H. Gulick, selling agent, 553 Mission St., San Francisco.
National Valve Company, 23-25 Minna St., San Francisco.
Pacific Sanitary Manufacturing Co., 67 New Montgomery St., San Francisco.
George H. Tay Company, Mission and Second Sts., San Francisco; 10th and Harrison Sts., Oakland.
Standard Metals Mfg. Co., 1300 N. Main st., Los Angeles.
West Coast Porcelain Manufacturers, Rialto building, San Francisco.
Wm. F. Wilson Co., 328 Mason St., San Francisco.
- POWER PLANTS**
Knittle-Cashel Co., Inc., 1820 Ellis St., San Francisco.
- POWER TRANSMITTING MACHINERY**
Meese & Gottfried, San Francisco, Los Angeles, Portland, Ore., and Seattle, Wash.
- PUMPS**
Chicago Pump Co., represented by Garnett, Young & Co., 612 Howard St., San Francisco.
California Hydraulic Engineering & Supply Co., 70 Fremont St., San Francisco.
Simonds Machinery Co., 117 New Montgomery St., San Francisco.
Ocean Shore Iron Works, 558 Eighth St., San Francisco.
Pacific Pump & Supply Company, 851-853 Folsom St., San Francisco.
George H. Tay Company, Mission and Second Sts., San Francisco; 10th and Harrison Sts., Oakland.
- PUMPS—HAND OR POWER, FOR OIL AND GASOLINE**
S. F. Bowser & Co., Inc., 612 Howard St., San Francisco.

DUNN SPRAY METHOD OF PAINTING

Saves Time, Labor and Material. Will outwear paint applied by other methods.
→ RONFLE Special Paints for Specific Purposes Used Unless Otherwise Specified.

PACIFIC PAINTING AND ROOFING COMPANY

G. D. NEWTON, Manager

PACIFIC BLDG., SAN FRANCISCO. 388 - 12th St., OAKLAND



Yards { TRACY, CAL.
BRENTWOOD, CAL.

Phone KEARNY 2074

PORTLAND LUMBER COMPANY

A. J. RUSSELL, Agent

LUMBER

SIMPLEX SILOS
SAGINAW SPECIAL SHINGLES
*Ship Timbers, Oil Rigs and
Special Bills Cut to Order.*

16 California Street

San Francisco, Cal.

from tree to Consumer

Pine and Redwood Lumber

SASH DOORS AND MILL WORK

SUNSET LUMBER COMPANY

MANUFACTURERS — WHOLESALE AND RETAIL

Main Office and Yards:

FIRST AND OAK STREETS, OAKLAND

Phone Oakland 1820

POPE & TALBOT

Manufacturers, Exporters and Dealers in

Lumber, Timber, Piles, Spars, etc.

Office, Yards and Planing Mills

859-869 THIRD ST., SAN FRANCISCO, CAL.

Mills, Port Gamble, Port Ludlow and Utsalady, Washington

PACIFIC MANUFACTURING COMPANY

MILLWORK, SASH AND DOORS

Hardwood Interior Trim a Specialty

Main Office:

SANTA CLARA, CALIF.

SAN FRANCISCO, 177 Stevenson Street
OAKLAND, 1001 Franklin Street

LOS ANGELES, 908 Washington Building
SAN JOSE, 16 North First Street

ARCHITECTS' SPECIFICATION INDEX—Continued**PUMPS (Continued)**

- S. T. Johnson Co., 1337 Mission St., San Francisco.
 Wayne Oil Tank & Pump Co., 631 Howard St., San Francisco; 830 S. Los Angeles St., Los Angeles.
 George H. Tay Company, Mission and Second Sts., San Francisco; 10th and Harrison Sts., Oakland.

RADIATOR TRAPS

- C. A. Dunham Co., Sheldon Bldg., San Francisco.

REINFORCING STEEL

- Edward L. Soule, Rialto Building, San Francisco.
 Gunn, Carle & Co., Inc., 444 Market street, San Francisco.
 Pacific Coast Steel Co., Rialto Building, San Francisco.
 Truscon Steel Co., 527 10th St., San Francisco.

REFRIGERATORS

- McCray Refrigerator Company, San Francisco office, 765 Mission street.

REVERSIBLE WINDOWS

- Hauser Window Company, 157 Minna St., San Francisco.

ROOFING CONTRACTORS

- Bender Roofing Company, Monadnock Bldg., San Francisco.
 National Roofing Company, Pacific Roofing Co., C. G. Williams, A. K. Goodmundson, 2140 San Pablo ave., Oakland.

ROOFING AND ROOFING MATERIALS

- "Malthoid" and "Ruberoid," manufactured by Paraffine Companies, Inc., San Francisco.
 United Materials Co., Crossley Bldg., San Francisco.
 H. H. Robertson Co., Hobart Bldg., San Francisco.
 California Brick Company, 604 Mission street, San Francisco.

RUBBER TILING

- New York Belting and Packing Company, 518 Mission St., San Francisco.

SAFETY TREADS

- Pacific Materials Co., 525 Market St., San Francisco.

SAND

- Del Monte White Sand, Del Monte Properties Co., 401 Crocker Bldg., San Francisco.

SASH CORD

- Samson Spot Sash Cord, John T. Rowntree, Pacific Coast Agent, San Francisco and Los Angeles.

SCENIC PAINTING—DROP CURTAINS, ETC.

- The Edwin H. Flagg Scenic Co., 1638 Long Beach Ave., Los Angeles.

SCHOOL FURNITURE AND SUPPLIES

- C. F. Weber & Co., 985 Market St., San Francisco; 512 S. Broadway, Los Angeles.
 Rucker-Fuller Desk Company, 677 Mission St., San Francisco.

SHEATHING AND SOUND DEADENING

- Samuel Cabot Mfg. Co., Boston, Mass., agencies in San Francisco, Oakland, Los Angeles, Portland, Tacoma and Spokane.
 The Paraffine Companies, Inc., 34 First St., San Francisco.

SHEET METAL WORK

- Forderer Cornice Works, 269 Potrero ave., San Francisco.
 U. S. Metal Products Co., 330 10th street, San Francisco.
 Fire Protection Products Co., 3117 20th street, San Francisco.

SHINGLE STAINS

- Bass-Ilueter Paint Company, all principal Coast cities.
 Cabot's Creosote Stains, sold by Pacific Building Materials Co., 525 Market St., San Francisco.

- Fuller's Pioneer Shingle Stains, made by W. P. Fuller & Co., San Francisco.
 Argonaut Shingle Stains, The Glidden Co., 123 Hooper St., San Francisco.

SHINGLES—STONE

- McClenanah Products Co., Inc., 670 Howard St., San Francisco.

SINKS—COMPOSITION

- Petrium Sanitary Sink Co., Fifth and Page Sts., Berkeley.

STATIONERY AND SUPPLIES

- Schwabacher-Frey Stationery Co., 609 Market St., San Francisco.
 H. S. Crocker Co., 565 Market street, San Francisco.

STEEL HEATING BOILERS

- California Hydraulic Engineering & Supply Co., 70-72 Fremont St., San Francisco.
 General Boilers Co., 332 Monadnock Bldg., San Francisco.

STEEL TANKS, PIPE, ETC.

- Ocean Shore Iron Works, 558 Eighth St., San Francisco.
 S. T. Johnson Co., 1337 Mission St., San Francisco.

STEEL AND IRON—STRUCTURAL

- Central Iron Works, 621 Florida St., San Francisco.
 Mortenson Construction Co., 19th and Indiana Sts., San Francisco.
 Pacific Rolling Mills, 17th and Mississippi Sts., San Francisco.
 Palm Iron & Bridge Works, Sacramento.
 U. S. Steel Products Co., Rialto Bldg., San Francisco.
 Schrader Iron Works, Inc., 1247 Harrison St., San Francisco.
 Western Iron Works, 141 Beale St., San Francisco.

STEEL PRESERVATIVES

- Hill, Hubbell & Company, No. 1 Drumm St., San Francisco.

STEEL ROLLING DOORS

- Pacific Building Materials Co., Underwood Bldg., San Francisco.
 J. G. Wilson Corporation, 600 Metropolitan Bldg., Los Angeles.

STEEL SASH

- Bayley-Springfield solid steel sash, sold by Pacific Materials Co., 525 Market St., San Francisco.
 "Fenestra," solid steel sash, manufactured by Detroit Steel Products Company, Detroit, Mich. Direct factory sales office, Foxcroft Bldg., San Francisco.
 U. S. Metal Products Company, 330 Tenth St., San Francisco.
 Truscon Steel Company, 527 Tenth street, San Francisco.

STORE FRONTS

- The Kawneer Manufacturing Company, West Berkeley, California.
 Zouri Safety Sash Bars—Cobbledick-Kibbe Glass Company, 175 Jessie St., San Francisco.

STUDDING—FIREPROOF STEEL

- Steel Studding Company, 1216 Folsom St., San Francisco.

SUMP AND BILGE PUMPS

- California Hydraulic Engineering & Supply Co., 70-72 Fremont St., San Francisco.

MOLINE HEAT

Hobart Building

San Francisco

TELEPHONE SUTTER 3818

ARCHITECTS' SPECIFICATION INDEX—Continued

SWITCHES

Wemco Safety Switch, manufactured and sold by W. E. Mushet Co., 502 Mission St., San Francisco.

Western Electric Safety Switch Co., Inc., 247 Minna street, San Francisco.

TELEPHONE AND ELECTRIC EQUIPMENT

Direct Line Telephone Co., 320 Market St., San Francisco.

THEATER AND OPERA CHAIRS

C. F. Weber & Co., 365 Market St., San Francisco.

Rucker-Fuller Desk Co., 677 Mission St., San Francisco.

THERMOSTATS FOR HEAT REGULATION

Johnson Service, Rialto Bldg., San Francisco.

TILES, MOSAICS, MANTELS, ETC.

Mangrum & Otter, 827-831 Mission St., San Francisco.

TILE FOR ROOFS

Cannon & Co., Sacramento; and 77 O'Farrell St., San Francisco.

California Brick Company, 604 Mission street, San Francisco.

Gladding, McBean & Co., Crocker Bldg., San Francisco.

United Materials Co., Sharon Bldg., San Francisco.

TRANSMISSION MACHINERY

Messe & Gottfried Co., San Francisco, Los Angeles and Portland.

VACUUM CLEANERS

United Materials Co., Sharon bldg., San Francisco; makers of Tucc Cleaners, sold in California by San Francisco Compressed Air Cleaning Co., Stockton and Sutter Sts., San Francisco.

VALVES—PIPES AND FITTINGS

California Steam & Plumbing Supply Co., 671 Fifth St., San Francisco.

Crane Radiator Valves, manufactured by Crane Co., Second and Brannan Sts., San Francisco.

National Valve Company, 23-25 Minna St., San Francisco.

Grinnell Co., 453 Mission St., San Francisco.

O. M. Simmons Co., 115 Mission St., San Francisco.

H. Mueller Mfg. Co., 635 Mission St., San Francisco.

W. E. Mushet Co., 502 Mission St., San Francisco.

George H. Tay Company, Mission and Second Sts., San Francisco; 10th and Harrison Sts., Oakland.

Shroeder Direct Flush Valves, mfrd. by Standard Metals Mfg. Co., 1300 N. Main street, Los Angeles.

VALVE PACKING

N. H. Cook Belting Co., 317 Howard St., San Francisco.

Everlasting Blow-off Valves. General Machinery and Supply Co., 39 Stevenson street, San Francisco.

VARNISHES

Bass-Hueter Paint Company, Mission, near 4th street, San Francisco, and all principal coast cities.

California Paint Company, 1797 Twelfth St., Oakland.

W. P. Fuller Co., all principal Coast cities.

R. N. Nason & Co., San Francisco, Los Angeles, Portland and Seattle.

Standard Varnish Works, 55 Stevenson St., San Francisco.

VENETIAN BLINDS, AWNINGS, ETC.

C. F. Weber & Co., 985 Market St., San Francisco.

Western Blind & Screen Co., 2702 Long Beach Ave., Los Angeles.

VITREOUS CHINAWARE

Pacific Porcelain Ware Company, 67 New Montgomery St., San Francisco.

West Coast Porcelain Manufacturers, Rialto Building, San Francisco.

WALL BEDS, SEATS, ETC.

Marshall & Stearns Co., 1154 Phelan Bldg., San Francisco.

WALL BOARD

"Amiwood" Wall Board, manufactured by The Paraffine Companies, Inc., 34 First St., San Francisco.

WALL PAINT

Nason's Opaque Flat Finish, manufactured by R. N. Nason & Co., San Francisco, Portland and Los Angeles.

San-A-Cote and Vel-va-Cote, manufactured by the Brininstool Co., Los Angeles.

WALL PAPER AND DRAPERIES

Arthur Brown, Foxcroft Bldg., San Francisco.

Beach-Robinson Co., 239 Geary St., San Francisco.

The Tormey Co., 681 Geary St., San Francisco.

W. & J. Sloane, 216-228 Sutter St., San Francisco.

Uhl Bros., San Francisco.

WATERPROOFING FOR CONCRETE, BRICK, ETC.

Armortec Damp Resisting Paint, made by W. P. Fuller & Co., San Francisco.

Bay State Brick & Cement Coating, manufactured by Wadsworth, Howland Co., Boston; Hambley & Son., Distributors for Northern and Southern California.

Gunn, Carle & Co., Inc., "Hydrate," 444 Market street, San Francisco.

Imperial Waterproofing, mfrd. by Brooks & Doerr, Reed Baxter, agent, Merchants National Bank Bldg., San Francisco.

Pacific Materials Co., 525 Market St., San Francisco.

Samuel Cabot Mfg. Co., Boston, Mass., agencies in San Francisco, Oakland, Los Angeles, Portland, Tacoma and Spokane.

WATER SUPPLY SYSTEMS

Kewance Water Supply System—Simonds Machinery Co., agents, 117 New Montgomery St., San Francisco.

Pacific Pump & Supply Company, 851-853 Folsom St., San Francisco.

Smith-Booth-Usher Co., San Francisco and Los Angeles.

Baird-Bailbache Co., 478 Sutter street, San Francisco.

WHEELBARROWS—STEEL

Western Iron Works, Beale and Main Sts., San Francisco.

WHITE ENAMEL

"Gold Seal," manufactured and sold by Bass-Hueter Paint Co. All principal Coast cities.

"Silkenwhite," made by W. P. Fuller & Co., San Francisco.

"Satinette." Standard Varnish Works, 55 Stevenson St., San Francisco.

WINDOW SHADES

W. & J. Sloane, 216-228 Sutter St., San Francisco.

WINDOW SASH CORD

Sampson Spot Cord, John T. Rowntree, Pacific Coast agents, San Francisco and Los Angeles.

WINDOWS, REVERSIBLE, CASEMENT, ETC.

Hauser Window Co., 157 Minna St., San Francisco.

The Kawneer Company, West Berkeley, California. (Simplex Fixtures.)

J. G. Wilson Corporation, 600 Metropolitan Bldg., Los Angeles; Waterhouse-Wilcox Co., Underwood Bldg., San Francisco.

WIRE FENCE

Standard Fence Co., 245 Market street, San Francisco; and 310 12th street, Oakland.

WOOD MANTELS

Fink & Schindler, 218 13th St., San Francisco.

Mangrum & Otter, 827 Mission St., San Francisco.

W. E. JOHNSTON

V. A. ANDERSON

Life Insurance Engineers

Submit your INSURANCE PROBLEMS to us.

210 Crocker Building, San Francisco

Phone Kearny 4048

MOTT PLUMBING FIXTURES

Architects and their clients are invited to visit our Showrooms, 553-555 Mission Street, San Francisco; D. H. Gulick, Sales Agent. Los Angeles Office, 1001 Central Building; J. R. Mayhew, Sales Agent.

Mott Company of California

MUELLER — BRASS GOODS

Recognized as the Standard of excellence in plumbing. It pays to use them, and other **Mueller** Brass Goods. *The first cost is practically their last cost.*

H. Mueller Mfg. Co.
635 MISSION STREET, SAN FRANCISCO, CAL.

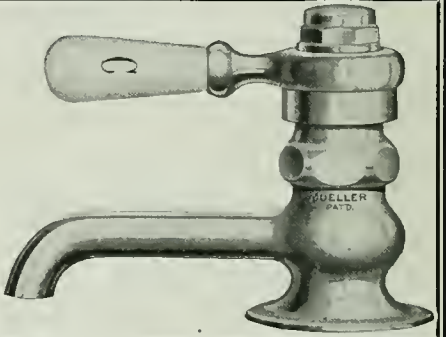

STORM KING and AMERICAN WARM AIR FURNACES

FURNACE FITTINGS AND REPAIRS

Montague Range & Furnace Company

327-329 JESSIE STREET

Phone Garfield 1422

826-830 MISSION STREET

SAN FRANCISCO, CALIF.

**DON'T NEGLECT YOUR HEATING SYSTEM.
THE BEST IS NONE TOO GOOD!**

All kinds of Galvanized Iron Work — Furnaces, Pipes, Ventilators — Sheet Metal for Planing Mills, Fruit Dryers, Rice Mills. Kitchen Equipment, including Steam Tables, Sinks, Canopies, Urn Stands, Etc.

JAMES A. NELSON

Heating and Ventilating Contractor

Phone, Garfield 1959

517-519 SIXTH ST., SAN FRANCISCO



Residence of H. R. Neitzel, Boise, Idaho

Neitzel's Choice

WHEN H. R. Neitzel erected his home—he insisted it should be pleasing to the eye, conducive to personal well-being, and enduring. His requirements were fulfilled. It was logical that he selected the products of W. P. Fuller & Co. for his home.

PIONEER WHITE LEAD was used on the exterior trim, for Boise has an exacting climate. Pioneer White Lead endures in all climates.

FULLER'S FORTY FOR FINISHING was chosen because it gave the interior of his home a finish that was most pleasing,—and enduring.

MORE and more,—architects, builders and owners are specifying Fuller's Paints, Varnishes and Enamels, which please the eye, induce well-being—and Endure.

FIFTY FOR FLATTING was specified because Mr. Neitzel wanted the woodwork to possess a finish that one instinctively associates with homes of this type.

FIFTEEN FOR FLOORS gave his floors a beautifully polished appearance,—a refinement that persistently remains. Fifteen for Floors has lasting and beautifying qualities.

W. P. FULLER & CO.

"Since '49"

PAINTS

ENAMELS

VARNISHES

San Francisco
Oakland

Stockton
Sacramento

Los Angeles
San Diego

Santa Monica
Pasadena

Hollywood
Portland

Tacoma
Seattle

Spokane
Boise

Salt Lake City
Long Beach

CHICAGO

Condensation Pumps
Sewage Ejectors
Bilge Pumps

PUMP COMPANY

Garnett Young and Company

Pacific Coast Sales Engineers

612 Howard Street, San Francisco

SEATTLE

LOS ANGELES

PORTLAND

ATTRACTIVE HOMES

BEAUTIFUL Stucco Exteriors for
Residential Work made possible
by using a combination of

**DEL MONTE
WHITE SAND**

and

**FAN SHELL
BEACH SAND**

with

WHITE PORTLAND CEMENT



STUCCO RESIDENCE, SAN JOSE
Wm. H. Weeks, Architect

Del Monte Properties Co.

Phone Sutter 6130

401 Crocker Building, San Francisco

OAK FLOORS

(For Everlasting Economy)



“**OAK** FMA-USA”

means

American Oak

This trade-mark, stamped on every stick, identifies the genuine American-grown Oak Flooring.

It protects you and your clients against the substitution of the cheaper but much inferior Japanese Oak Flooring now being brought into this country.

An investigation will convince you that American Oak Flooring is far superior to Japanese Oak Flooring in every way.

The Japanese product is made of matured timber. Much of it can be easily broken, showing its

brashy nature, while the frequent occurrence of soft boards causes a floor to fill unevenly, giving a spotty finish.

There have been many cases recently where contractors were obliged to tear up Japanese Oak Flooring and replace it with American—a costly lesson.

For the sake of your own reputation as well as the interests of your clients, you should watch closely all jobs on which you specify or recommend Oak Flooring. Insist on this trade-mark.



Send for our free literature on Oak Flooring. It will be helpful to you in the practice of your profession. And do not hesitate to write us whenever you are seeking information about Oak Flooring.

OAK FLOORING MERCHANT ASSN.

1036 Ashland Block, Chicago, Ill.



See page 389, Sweet's Catalogue, for specifications of various grades.



Brininstool

San - a - Cote

(GLOSS—Can be Scrubbed)

AN INTERIOR WALL FINISH

For bath rooms, kitchens, hospitals, schools, office and public buildings. Ask dealers, owners, architects and contractors about this durable, sanitary, washable, economical wall covering. Brininstool makes a paint for every purpose, and every can purposely good.

THE BRININSTOOL CO., LOS ANGELES

COLOR GRINDERS AND PAINT MANUFACTURERS

Distributors—The Brininstool Co., 1174 Phelan Bldg., San Francisco, Cal.; The Brininstool Co., 222 Abington Bldg., Portland, Ore.; Schutz Paint Co., Fresno, Cal.; Schneider, Chappell & Jones, Sacramento, Cal.; Salt Lake Glass & Paint Co., Salt Lake City, Utah; Griffin Paint Co., Ogden, Utah; Campbell Hardware Co., First and Madison Sts., Seattle, Wash.; Imperial Valley Hardware Co., El Centro, Calexico, Imperial, Brawley, Seeley, Cal.; Spokane Hardware Co., Spokane, Wash.; Continental Paint Company, 328 South First St., San Jose, Cal.; Los Angeles Wallpaper & Paint Co., 525 So. Main St., Los Angeles, Cal.; H. A. Berger, 3838 13th St., San Diego, Cal.; H. L. Christian, Elythe, Cal.; Ezra Thayer, Phoenix, Ariz.; Miami Lumber & Supply Co., Miami, Ariz.

RELIANCE BALL BEARING DOOR HANGERS

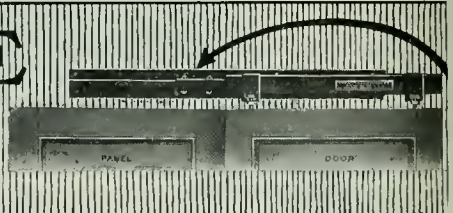

To get as near perfection as possible, use

RELIANCE "HANGERS" and "Reliance-Grant" Controllers

These insure fast service, practically noiseless and slamless doors.

Reliance-Grant Elevator Equipment Corp'n

PARK AVENUE AND 40TH STREET, NEW YORK

PACIFIC COAST AGENTS

Waterhouse-Wilcox Co.
Columbia Wire & Iron Works
D. E. Fryer & Company

San Francisco and Los Angeles, Cal.
Portland, Ore.
Seattle, Spokane, Tacoma, Wash. and Great Falls, Mont.



Keep Down Insurance Premiums

SPECIFY

SAINO FIRE DOORS

Standard Automatic Sliding or Swinging Fire Doors.
Tested and Labeled by the Underwriters' Laboratories.

STEEL SASH AND HOLLOW METAL
UNDERWRITERS WINDOWS

U. S. METAL PRODUCTS CO.

326-338 Tenth Street, San Francisco



ABOVE is shown an interesting residence designed for Mr. Robert Payson, Cape Elizabeth, Maine, by Messrs. John Calvin Stevens, F. A. I. A., and John Howard Stevens, of Portland.

The wall was sheathed horizontally, and the sheathing covered with waterproof paper. The wood furs, 1 x 3 strips, split and beveled, were laid vertically 8" on centers. On these was nailed expanded metal lath, and the first coat of stucco was so troweled in as to completely fill the space between lath and sheathing paper. By constant troweling from the bottom upward, tendency to sag and bulge was overcome.

The second coat completely covered the lath, and the third coat—of Medusa Stainless White Cement Waterproofed, was applied "slap-dash" finish. The trellises over the stucco lend an interesting touch, while the white birches add harmony to the entire scheme.

Medusa Stainless White Cement will not streak nor discolor. It may be easily scrubbed to its original whiteness at any time, should its surface become gray from soot or grime.

Medusa Waterproofing, mixed in as an integral part of the cement, permanently excludes all moisture or dampness. Interesting booklets, containing full information on all "Medusa" Products, gladly sent by The Sandusky Cement Company, Department P, Cleveland, Ohio, manufacturers of Medusa Stainless White Cement (Plain or Waterproofed) and Medusa Waterproofing (Powder or Paste, to be added to cement while mixing.)

PACIFIC COAST DISTRIBUTORS

Pacific Materials Co., San Francisco, Cal. Riverside Portland Cement Co.,
Los Angeles, Cal. A. McMillan & Company, Portland, Ore. Galbraith &
Company, Seattle, Wash.



MEDUSA STAINLESS WHITE CEMENT *Waterproofed*



When writing to Advertisers please mention this magazine.

CANNON & CO.

Clay Products

Denison Interlocking Tile

Face Brick

Hollow Tile

Roof and Floor Tile

OFFICE:

Building Material Exhibit, 77 O'Farrell St., San Francisco

Telephone Sutter 5333

Factory and General Offices:

Sacramento, California

GENERAL BOILERS COMPANY

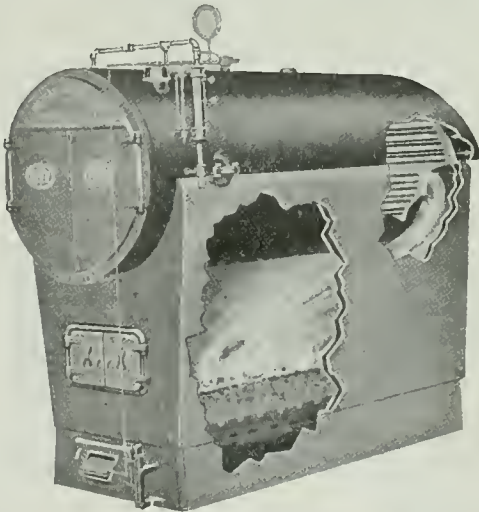

General Office and Plant:
WAUKEGAN, ILLS.

Manufacturers of
"PACIFIC"

STEEL HEATING BOILERS
AND
CIRCULATING TANKS

DEPARTMENT OF SALES:

322 MONADNOCK BUILDING, SAN FRANCISCO.

Telephone Sutter 4665

Architects —

*Here's an
Innovation
in
Bathroom
Fixtures*

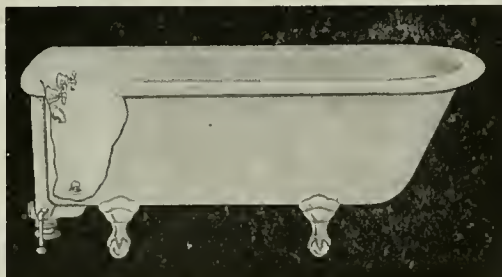

All-in-One

Bath Tub and Lavatory

All-in-One—hot and cold water inlets, waste pipe, overflow integral and bath cocks all cast with the tub or lavatory itself, eliminating the connecting joints of the old style tub, facilitating installation and adding greatly to the beauty and utility of the fixture.

No metal work above the slab—the entire fixture is finished in white enamel, eliminating the care required to keep ordinary metal parts clean. The All-In-One Lavatory has the additional feature of mixing the hot and cold water.

1921 home builders will prefer these new and better

bathroom fixtures. And they cost no more than the old style tub or lavatory with its many parts.

Write today for catalog.

Made in All Sizes and Styles

All-in-One Company

Dept. A

Oschner Building
Sacramento, Calif.



(Pat. Applied For)

How daylight helps workmen do more and better work

DAYLIGHT and fresh air are powerful aids to production. The stimulus of plenty of light and fresh air is reflected in greater volume and accuracy of output, with diminished wastage. Operatives enjoy better health, are freer from eye-strain, lose fewer days through sickness. Labor turnover is reduced—output is noticeably increased. All of this is accomplished with TRUSCON Daylight Sash.

Truscon Daylight Engineers at your Service

All sizes of Truscon Steel Sash carried in stock in San Francisco Warehouse.

Largest stock of fireproof material and reinforcing bars on the Pacific Coast.

TRUSCON STEEL COMPANY

CHAS. HOLLOWAY, JR., Branch Manager

527 Tenth Street, San Francisco

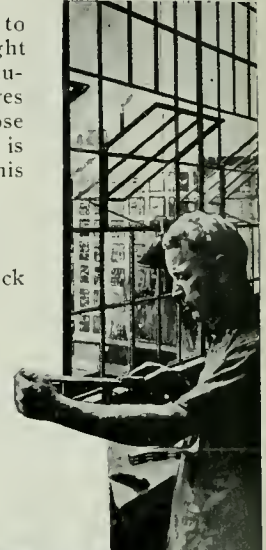

TRUSCON DAYLIGHT SASH

Ford

Whether for commercial purposes or pleasure, the Ford car will answer any requirement. It has proven its worth in every field of endeavor.

For eighteen years we have catered to the wants of the Ford buying public.

We can offer you the benefits of that long experience by giving you the acme of service through our coastwise organization.

William L. Hughson Co.

Since 1903

Geary at Van Ness, San Francisco

Prospect 607



Seattle

Portland

Oakland

Los Angeles

San Diego

**LA FRANCE SAFETY DEVICES
FOR EVERY INDUSTRY**

**Consider Fire Protection
in Making Your Plans**



If you are planning a factory provide a space for a LaFrance No. 20 Chemical Engine, for it is simple in construction and easy to operate. It contains twenty gallons of fluid forty times as effective as water for extinguishing fires. It is made by the world's largest manufacturer of fire apparatus, with a full knowledge of what is best for effective fire fighting.

Write for complete information in regard to this and our other appliances, such as Hose, Hose Racks, Reels, Nozzles, Axes and many others.

AMERICAN LA FRANCE FIRE ENGINE COMPANY, INC.

ELMIRA, N. Y.

929 South Hill Street,
Los Angeles, Calif.



151 New Montgomery
Street, San Francisco,
Calif.



Beach-Robinson Co.

Decorators and Furnishers

Carpets

Draperies

Furniture

Rugs

Wall Paper

Ranson E. Beach

239 Geary Street, 3d Floor

Union Square

Phone, Sutter 580

San Francisco, Cal.



**ADD CHEER and COMFORT
to the Home by having a
WELL DESIGNED INTERIOR**

Before Completing Your Plans, CONSULT

SONNENSCHN BROS.

INTERIOR DECORATORS

Furniture and Draperies Made to Order

Factory

718 NATOMA ST., Phone Market 1145

Show and Salesroom

470 SUTTER ST., Phone Kearny 2051



TAYLOR GALLERIES

Artistic Interiors

SPECIAL FURNITURE DRAPES - WALL PAPER

1818 Harrison St., near 19th, Oakland, Calif.

Phone Lakeside 3107

The GOLD MEDAL MAIL CHUTE



INSTALLED IN
THE NEW
SAN FRANCISCO
CITY HALL
AND THE
WHITE MARBLE
MERRITT
BUILDING,
LOS ANGELES

Given highest award at
Panama - Pacific International
Exposition, 1915.

Waterhouse-Wilcox Co.

California
Representatives

523 Market Street
SAN FRANCISCO

331 E. 4th Street.
LOS ANGELES

F. T. CROWE & CO.
Seattle, Wash.

THE J. McCracken Co.
Portland, Oregon

American Mailing
Device
Corporation

CLINTON

WELDED WIRE
FABRIC AND LATH

The Perfect Support for Stucco
and Interior Plaster. Complete
Stock for Immediate Delivery.
Steel Reinforcing Bars in Stock.

L. A. NORRIS CO.

140 Townsend Street

Phone Kearny 5375 San Francisco



MCCRAY REFRIGERATORS FOR ALL PURPOSES

It is our particular desire to
impress the Architects of
America with the fact that
McCray builds refrigerators
for all purposes. Thousands
of fine residences, hotels,
clubs, restaurants, factory
cafeterias, hospitals, stores and
markets depend on McCray
for efficient, economical re-
frigerator service.

MCCRAY REFRIGERATOR CO.
765 Mission Street, San Francisco, Calif.
Home Office and Factory
Kendallville, Ind

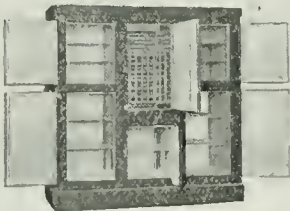

YOU KNOW that a building
should be watertight and

WE KNOW that it can be
made so with

IMPERIAL WATERPROOFING

LOOK FOR  THE LABEL

If your building is leaking through
the walls or around the windows, or
if the Basement walls are wet below
ground — call up SUTTER 978.

IMPERIAL WATERPROOFING
is manufactured by BROOKS &
DOERR, 460 7th St., San Francisco

WATEREX REED BAXTER
DISTRIBUTOR

1002-04 Merchants National Bank Building,
Phone Sutter 978

SAN FRANCISCO, CAL.

3419 Broadway, OAKLAND, CAL.

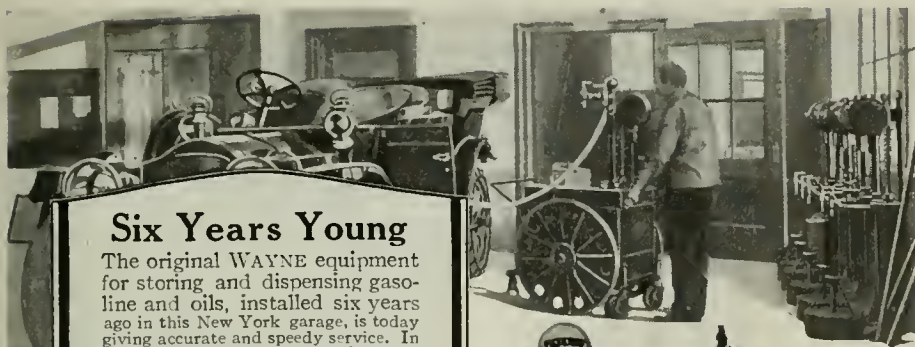

Six Years Young

The original WAYNE equipment for storing and dispensing gasoline and oils, installed six years ago in this New York garage, is today giving accurate and speedy service. In Wayne pumps the delicate adjustment essential for accuracy is combined with a durability that assures satisfaction for years and years.

There is a Wayne System for every need of the public garage. The service of Wayne engineers in advising and planning is yours without cost or obligation.

Wayne Oil Tank & Pump Co.
746 Canal St., Ft. Wayne, Ind.

San Francisco Office
631-633 Howard St.
Phone Garfield 1350

Los Angeles Office
830 S. Los Angeles St.
Phone Main 1600

Wayne
REG. U.S. PAT. OFF.
TRADE MARK
Liquid Storage Systems

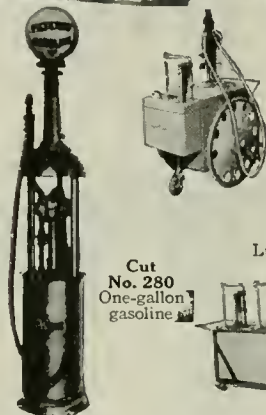

Cut No. 230
For Gas and Oil

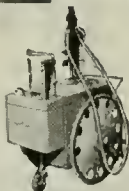

Cut No. 200
Lubricating oils

Cut No. 280
One-gallon gasoline



For the
Exacting Client

Pitcher Hangers

Give Satisfaction

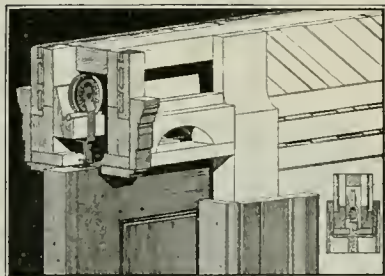

Smooth Running — Noiseless — Efficient
Inexpensive

MANUFACTURED BY

NATIONAL MILL & LUMBER CO.

318 Market Street, San Francisco, Cal.

Telephone Kearny 3626

**THE HOME
of
BYBAMOPA
WARE**

You are cordially
invited to visit the
**FREEMAN
ART
SHOP**

Where there is
displayed only the
unusual and ex-
clusive things in
Lamp Shades,
Mirrors, Candle
Sticks, Candles,
Book Ends,
Oriental Rugs,
Pottery, Bronzes,
Solid Mahogany
Furniture, Oil
Paintings, Pastels,
Fine Prints,
Greeting Cards,
Picture Framing.

386 SUTTER
ST., at Stockton
Interior Decorating

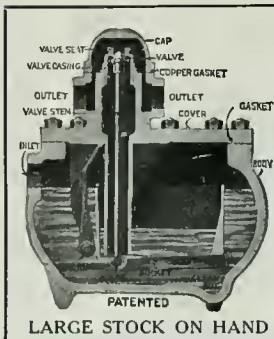

GENUINE SQUIRES STEAM TRAPS

Great Durability and High Efficiency.
Main joints above water line.
Valve and Seat accessible without breaking joints.
Every Trap unconditionally guaranteed.

W. E. MUSHET & CO

SOLE AGENTS
Phone Sutter 4797



502 Mission Street
San Francisco, Cal.



Sturdy Simplicity

In what has been said to be one of the most modern machine shops west of the Mississippi, Dunham Traps are made with extreme care and accuracy.

The result is *sturdy simplicity*. Nothing could be more simple than the two-piece Dunham Trap; and judging from service records of those in use since 1903, Dunham sturdiness is exceptional.

The Dunham Radiator Trap maintains a radiator at its maximum heating efficiency by permitting the passage of all air and water from the radiator and holding all steam within the radiator until it gives up its heat.

Complete data on request.

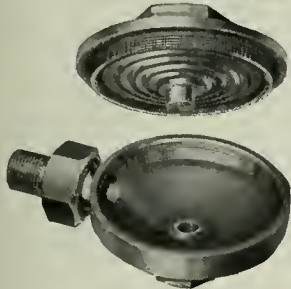

The Dunham Radiator Trap consists of two major parts, a body and a cover holding the thermo-static disc. The man is linning the disc before soldering it.

The DUNHAM
REG. TRADE-MARK
 HEATING SERVICE

C. A. DUNHAM CO., Fisher Bldg., Chicago

Factories: Marshalltown, Iowa; Toronto, Canada

52 Branch and Local Sales Offices in the United States and Canada

London: 233 A, Regent Street, W. 1 Paris: Establs. Munzing & Cie., Rue de la Fontaine-au-Roi



TAY PIPE
 Valves & Fittings
 STEAM & WATER SUPPLIES
 Heating Material
 PLUMBING GOODS
 Pumps
GEORGE H. TAY COMPANY
 SAN FRANCISCO OAKLAND
 MISSION & SECOND STS. TENTH & HARRISON STS.
 TELEPHONE DOUGLAS 2240 TELEPHONE LAKEVIEW 4200

— for better *Lighting*

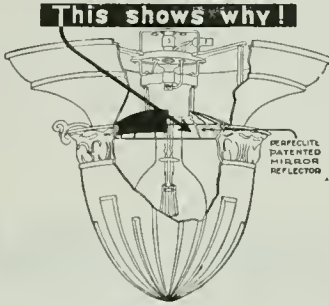

RECOMMEND and specify Perfectlite, the Master Lighting Fixture, for that fastidious client who wants all that is modern and best.

PERFECLITE is like its name. It represents a step forward in the age-long search for better lighting. The patented battery of mirrors — a new principle never before used — shows a wide area with a soft, yet brilliant light that more nearly reproduces sunlight than any other invention of man.

Over 40 styles to choose from for all kinds of residential and commercial installations. Study their quality and efficiency at either of our showrooms. If this isn't convenient send for art catalog of different styles.

Our illuminating specialists are ready to cooperate with you at all times

MYERS & SCHWARTZ

75 New Montgomery St.
San Francisco, Calif.
Phone Sutter 6178

1119 So. Los Angeles St.
Los Angeles, Calif.
Phone 15466



Bungalow Building Blox

Hollow Building Tile
Hollow Partition Tile

California Brick Co.

604 Mission Street
San Francisco, Cal.

BRICK

Red Ruffled Face Brick
Paving Brick
Step and Walk
Brick

BRICK

Enamel Brick
Buff and Old Gold
Pressed Brick

Livermore Fire Brick Works

604 Mission Street
San Francisco, Cal.

Fire Brick and
Molded Fire Tile

Architectural Terra Cotta

GLASS

FULLER & GOEPP

32 Page Street, San Francisco. Telephone Market 499
PRIVATE EXCHANGE CONNECTING ALL DEPARTMENTS
MANUFACTURERS OF

MIRRORS, ART AND LEADED GLASS

Dealers in **WHITE** Glass for Table Tops, Counter Tops, Sink
Backs & Etc. Complete Stock — Prompt Deliveries.

Passenger and Freight Elevators



"MADE IN SAN FRANCISCO"

Factory and Warehouse, 166-180 Seventh
Street, San Francisco. Phone Kearny 66

SPENCER ELEVATOR COMPANY



RA-DO FUMELESS GAS RADIATORS

ALL CAST IRON — 3 Sizes (3, 5, and 7 Sections)

The Ideal "Year-Round" Heating System
For The Home — New or Old

Easiest and Cheapest to Install
Lowest Operating Cost

BAIRD - BAILHACHE COMPANY

MANUFACTURERS

478 Sutter St., San Francisco

'Phone Sutter 6858

OLD MISSION PORTLAND CEMENT COMPANY



Each shipment of "OLD MISSION" Portland Cement is guaranteed not only to equal but to surpass all requirements of the standard specifications for Portland Cement as adopted by the U. S. Government and by the American Society for Testing Materials. A Guarantee Certificate is mailed with the bill of lading of each car, giving number of car, date packed, and number of barrels, over the signature of the chief chemist.

8000 SACKS DAILY

SALES OFFICE:

MILLS BLDG., SAN FRANCISCO
PHONE SUTTER 3075

PLANT:

SAN JUAN, CAL.

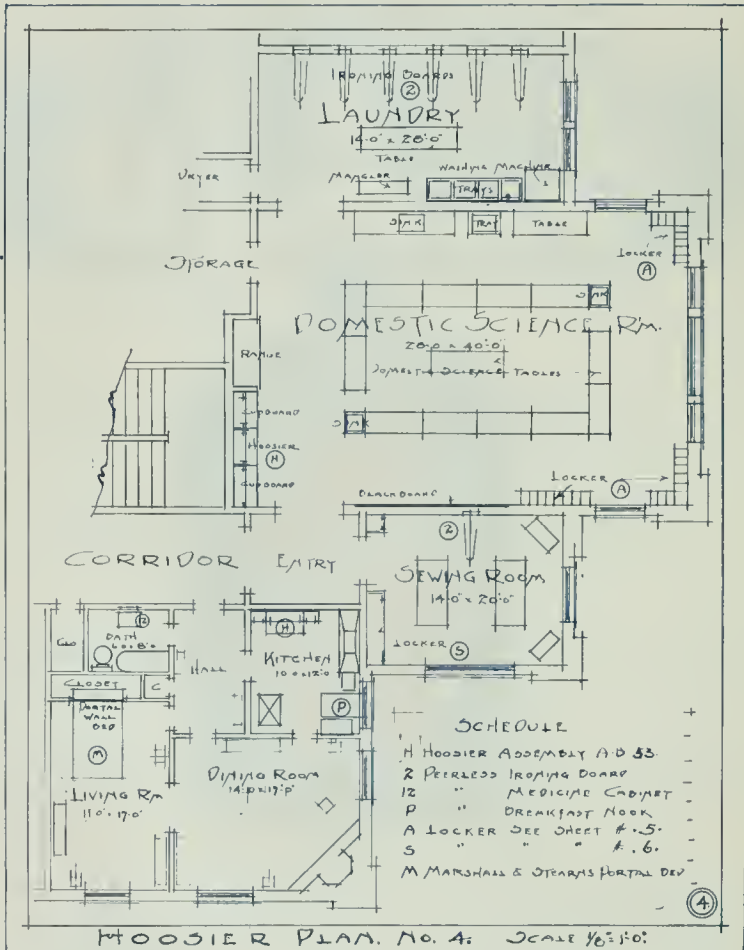

One of Many Suggestions

contained in a neat blueprint folder issued for the use of Architects, Engineers and School Boards. Many others less elaborate, as well as more comprehensive, are shown in the complete work.

Prepared by an expert after months of research and investigation of leading schools both east and west.

Write for it if interested in the latest study in a most important department of modern schools.

THE HOOSIER STORE

821 MARKET STREET

SAN FRANCISCO, CAL.

The Elevator Floor

whether in Office Building, Hotel or Department Store, is subjected to a great deal of wear and tear.

—SPECIFY—

INTERLOCKING RUBBER TILING

and you've provided your client's building with a Durable, Economical, Practical,

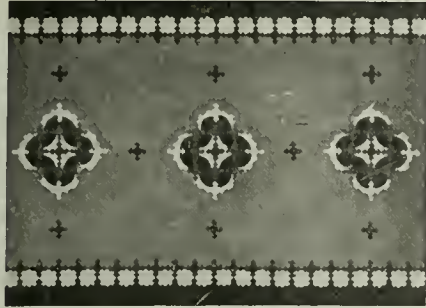

INTERLOCKING RUBBER TILING

material that is sure to give satisfaction. **Twenty tons installed in the Standard Oil Building, San Francisco.** Stock on hand for immediate delivery.



New York Belting and Packing Co.

NEW YORK

San Francisco Branch 519 MISSION ST. Phone Douglas 1837

Small booklet of designs mailed on request.

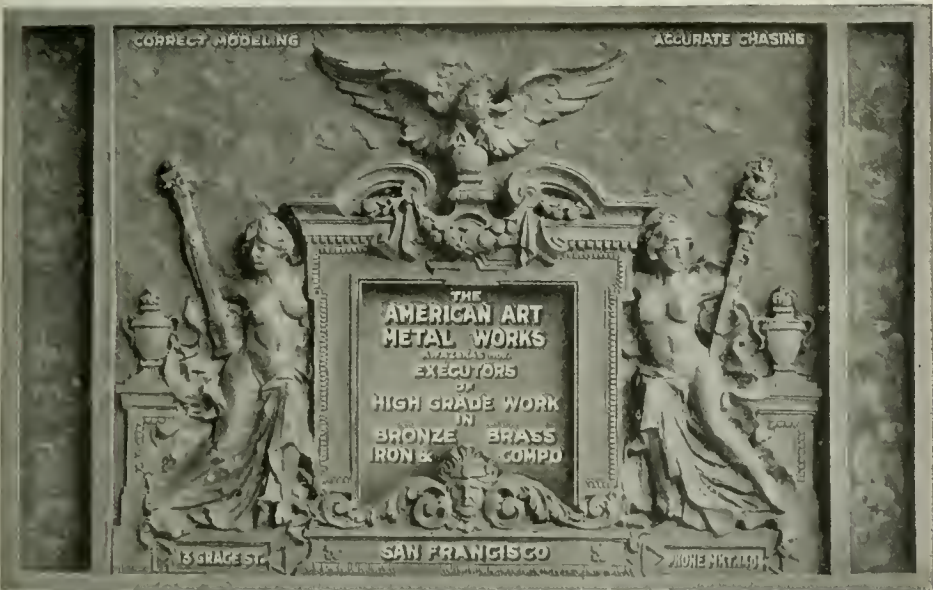

When writing to Advertisers please mention this magazine.

"LUXOR ENAMEL"

WHITE

HIGH GLOSS

MIRROR-LIKE FINISH

THE FINEST ENAMEL MADE FOR INTERIOR WORK

HIGH IN QUALITY — MEDIUM IN PRICE

UHL BROS., Inc.

SEATTLE

LOS ANGELES

PORTLAND

SAN FRANCISCO

OAKLAND

LEADER WATER SYSTEM

No country home is complete without this modern water system. Running water under pressure whenever and wherever needed. Convenient, economical, sanitary.

**Pacific Pump & Supply
Company, Distributors**

851-853 Folsom Street
SAN FRANCISCO, CALIF.

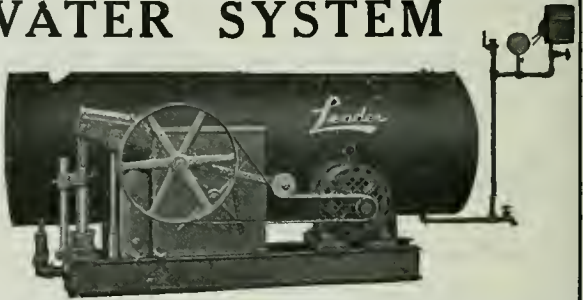

QUALITY HARDWARE



LOCKS AND BUILDERS'
HARDWARE

PALACE HARDWARE CO.

"San Francisco's Leading Hardware Store"

581 MARKET STREET. SUTTER 6060



Pack your Radiator Valves with
Palmetto Twist Packing

It can be unstranded to fit any
size valve. It does not get hard.

H. N. COOK BELTING CO.

401-433 Howard St.

San Francisco, Cal.

**WESTERN
VENETIAN BLINDS
WESTERN**

EELIMINATE the unsightly awnings — Preserve the exterior beauty of your buildings by
Specifying

**WESTERN VENETIAN
BLINDS**

Some 1920 contracts for complete equipment:

- 12-story Mattie Building,
Fresno, California
- 9-story Pantages Building,
Los Angeles, California
- 7-story Marland Refining Bldg.
Ponca City, Oklahoma
- 10-story Trademens Bank Bldg.
Oklahoma City, Okla.
- 5-story Railway Exchange,
Muskogee, Oklahoma



LOS ANGELES TRUST
AND SAVINGS BLDG.
LOS ANGELES CAL.



HAAS BLDG.
LOS ANGELES CAL.



CITIZENS SAVING
BLDG.
PASADENA, CAL.



GLOBE GRAIN &
MILLING CO.
LOS ANGELES CAL.



COUNTY COURT
HOUSE
WALLA WALLA, WASH.

When you consider the fact that **WESTERN VENETIAN BLINDS** take the place of both awning and window shade and will last practically as long as the building stands you'll realize that they are the logical equipment for modern buildings

WESTERN BLIND & SCREEN CO.
2704 LONG BEACH AVE.
LOS ANGELES CALIFORNIA

United States Steel Products Co.

Rialto Bldg., San Francisco

SELLERS of the products of the American Bridge Co., American Sheet and Tin Plate Co., American Steel and Wire Co., Carnegie Steel Co., Illinois Steel Co., National Tube Co., Lorain Steel Co., Shelby Steel Tube Co., Tennessee Coal, Iron and Railroad Co., Trenton Iron Co.

MANUFACTURERS OF

Structural Steel for Every Purpose—Bridges, Railway and Highway—"Triangle Mesh" Wire Concrete Reinforcement—Plain and Twisted Reinforcing Bars—Plates, Shapes and Sheets of Every Description—Rails, Splice Bars, Bolts, Nuts, etc.—Wrought Pipe, Trolley Poles—Frogs, Switches and Crossings for Steam Railway and Street Railway—"Shelby" Seamless Boiler Tubes and Mechanical Tubing—"Americore" and "Globe" Rubber Covered Wire and Cables—"Reliance" Weatherproof Copper and Iron Line Wire—"American" Wire Rope, Rail Bonds, Springs, Woven Wire Fencing and Poultry Netting—Tramways, etc.

United States Steel Products Co.

OFFICES AND WAREHOUSES AT
San Francisco - Los Angeles - Portland - Seattle



BOWSER - 35 Years and Never a Fire

MOTORISTS prefer to get their gasoline from a Bowser Piston Type Measuring Pump. Bowser Accuracy and Safety are two big reasons why.

Bowser all-metal construction eliminates danger of fire or explosion by making spillage and leaks impossible. A Bowser has never caused a fire or explosion. Accurate measurement is assured by the Bowser pump. The Piston will repeatedly draw the same quantity of gasoline into the government standard cylinder.

Write for our illustrated booklet, A-03.

S. F. BOWSER & COMPANY, Inc.

1303 E. Creighton Ave.,
FORT WAYNE, INDIANA

612 Howard Street,
San Francisco, Calif.

1225 So. Olive Street,
Los Angeles, Calif.

Offices in Principal Cities of World



Walls finished with Cabot's Old Virginia White
Roof finished with No. 316 Dark Gray Creosote Stain
Walter Boschen, Architect, St. Joseph, Mo.

The soft, brilliant "whitewash white" of the Old Virginia White is particularly suitable for this type of house, and the rich greens and velvety dark gray stains harmonize perfectly for the roof, with the old New England dark green blinds.

Samples and information sent on request

SAMUEL CABOT, Inc., Mfg. Chemists, Boston, Mass.

Cabot's Creosote Stains, Waterproof Cement, and Brick Stain
"Quilt" Conservo Wood Preservative, Damp-Proofing
Protective Paints, Waterproofing, etc.

Pacific Materials Co., San Francisco
Waterhouse-Witcox Co., Los Angeles

S. W. R. Dally, Seattle
Timms, Cress & Co., Portland

Theo. F. Snyder, San Diego, Cal.

The Latest Country-house Color-schemes

An especially appropriate and harmonious exterior color-treatment has been developed for the dignified and beautiful type of country-house that our leading architects have now firmly established, in place of the fifty-seven varieties that have prevailed in recent years.

Cabot's Old Virginia White,
for the walls

Cabot's Creosote Stains, in
greens or dark gray, for the roofs



CENTRAL HIGH SCHOOL, MINNEAPOLIS, MINN.

Architect, William B. Ittner

Contractors, Pike & Cook Co.

Glazed by Forman, Ford & Co



The above Trade-Mark
appears on every light

**Completely equipped with American Window Glass Co.'s Double Strength AA Quality
First Choice of Leading Architects**

Because of its absolute dependability, American Window Glass has been used in many fine buildings. Our care in inspection practically eliminates all imperfections and assures uniformity in thickness.

American Window Glass Co., General Office, Pittsburgh, Pa.

DOMESTIC SALES OFFICES

New York, 220 Fifth Avenue
Chicago, 1011 Peoples Gas Building
Boston, Mass., 43 Tremont Street
San Francisco, Cal., 862 Mission Street
St. Louis, Mo., 1303 Syndicate Trust Building
Memphis, Tenn., 440 North Main St.
New Orleans, La., 904 Hennen Bldg.
Atlanta, Ga., 1408 Candler Building

EXPORT SALES OFFICES

Havana, Cuba, Apartado No. 930
Buenos Aires, Argentina
Mexico City, Mex., Apartado Postal No. 237
Barranquilla, Colombia
Bogota, Colombia
Valparaiso, Chile
Lima, Peru
Toronto, Canada, 205 Continental Life Building



HERE IS SHOWN THE HANDY HOPPER DOOR OF

The
K E R N E R
"Built-in-the-Chimney"
INCINERATOR

which burns all garbage without a penny of cost. Into it is put all waste—everything from kitchen refuse to tin cans, and bottles.

The material deposited falls down the chimney flue to the incinerator built into the base of the chimney. Here it is ignited and burns itself up. The dry waste in burning dries the wet waste so it, too, can burn.

SANITARY — ECONOMICAL — CONVENIENT — ODORLESS

KERNER INCINERATOR CO.

377 O'Farrell St. SAN FRANCISCO Factory, 8 Stanford St.



SIMPLEX BURNERS

For High or Low Pressure Boilers, Water Heaters, Kiln Dryers, Furnaces, Etc. Operated by Fractional H. P. Motors. Guaranteed for Efficiency and Durability.

BUNTING IRON WORKS

TRADE MARK

Factory BERKELEY

1215 FIRST NATIONAL BANK BLDG.

SAN FRANCISCO Phone Sutter 3225

Member of the Oil Burners Manufacturers' Association of California.

Fess System Turbine Fuel Oil Burner

The latest word in the science of burning fuel oil in an efficient and economical method

Ask for Bulletin No. 20

FESS SYSTEM CO., Inc.

1310 S. HILL ST.,
LOS ANGELES

218-220 Natoma Street, San Francisco

HOUSTON,
TEXAS

Member of the Oil Burners Manufacturers' Association of California.

OIL BURNER EQUIPMENTS

Low Pressure Air and Rotary Mechanical Atomizing Types

Refrigerating and Ice-Making Machines

Direct Expansion and Brine Circulating Systems

T. P. JARVIS MANUFACTURING CO.

CONTRACTING ENGINEERS AND MANUFACTURERS

275 Connecticut Street, San Francisco

Phone Market 3397

Member of the Oil Burners Manufacturers' Association of California.

JOHNSON'S ROTARY CRUDE OIL BURNER

Can be installed in any BOILER or FURNACE

Gives Satisfactory Results. Simple to Operate—
Automatic—Safe. Let us tell you more about this
Oil Burner.

S. T. JOHNSON CO.

1337 Mission Street - San Francisco, Cal.

Ask for Bulletin No. 28

Phone Market 2759



BURNER IN OPERATION

Agencies: SEATTLE LOS ANGELES FRESNO SAN DIEGO SACRAMENTO
Member of the Oil Burners Manufacturers' Association of California.

When writing to Advertisers please mention this magazine.



Pump Governors	Oil Pumping Sets
Oil Burner Governors	Little Giant Improved
Reducing Valves	Oil Burners
Safety Valves	Duplex Oil Pumps
Oil Valves	Rotary Oil Pumps
Blowoff Valves	Oil Heaters
Boiler Feed Water	Draft Gauges
Regulators	Boiler Feed Pumps

G. E. WITT CO., Inc.
ENGINEERS

Manufacturers and Distributors

862-864 HOWARD ST.

Phone Douglas 4404

SAN FRANCISCO, CAL.

Chas. C. Moore Bldg.

Meyer & Johnson, Architects

Geo. Wagner, Gen. Contr.



VITRIFYX STOPPED
THE DUST IN THIS BUILDING

PACIFIC MATERIALS CO.
525 MARKET STREET, SAN FRANCISCO

A. F. EDWARDS, President
J. M. FABBRIS, Vice-President

J. A. MACKENZIE
Secretary

CHAS. F. EISELE } Asst. Managers
J. RUBIOLLO }

**AMERICAN
MARBLE & MOSAIC CO.**

25-29 Columbia Square, San Francisco

Telephone Market 5070

Factory on Canal, South San Francisco

Telephone South San Francisco 161



DETROIT STEEL PRODUCTS CO., Detroit

Direct Factory Branch, 68 Post Street, San Francisco

Phone Sutter 125



The Architect and Engineer

CONTENTS FOR MARCH, 1921

STAIRWAY, MISS BURKE'S SCHOOL, SAN FRANCISCO	PAGE Frontispiece
<i>Julia Morgan, Architect</i>	
SOME NEGLECTED ASPECTS OF SCHOOL ARCHITECTURE	47
<i>Charles K. Sumner, Architect</i>	
ARCHITECTURE, PLANNING AND CONSTRUCTION OF SCHOOLS	68
<i>John J. Donovan, Architect</i>	
CHURCH DOME AND SUPPORTING TRUSSES COLLAPSE . . .	99
<i>J. J. Rosedale, C. E.</i>	
EDITORIAL—	
DRASTIC CHANGES TO BURNETT HOUSING LAW . . .	102
THE HUGE WASTE IN TAX GATHERING	103
WITH THE ARCHITECTS	105
WITH THE ENGINEERS	109

PUBLISHED MONTHLY BY

THE ARCHITECT AND ENGINEER, INC.
626-27 FOXCROFT BUILDING, SAN FRANCISCO

W. J. L. KIERULFF
President

FREDERICK W. JONES
Vice-President

L. B. PENHORWOOD
Secretary



STAIRWAY, MISS BURKE'S SCHOOL, SAN FRANCISCO
JULIA MORGAN, ARCHITECT

THE ARCHITECT AND ENGINEER

MARCH
1921



Vol. LXIV
No. 3

Some Neglected Aspects of School Architecture

By CHARLES K. SUMNER, Architect

THE field of school architecture so fascinates the average aspiring architect that he invariably wants to jump straight to the middle of it, without pausing to view it thoughtfully as a whole, and without giving due attention to the many settled habits, conventions and prejudices by which it is hedged about. Those who have labored sufficiently in this field, however, will have had some of these limitations painfully brought to their attention, and will realize the need of a wider and clearer viewpoint. I propose, therefore, to go back and view this field of school architecture very briefly from the outside, as it were, and to sketch only in bare outline a few of its more or less neglected aspects. If what I shall find to say is largely by way of protest, let us indulge the hope that some of it may help pave the way to better things.

No one can have more than a few rational and consecutive thoughts upon public education without questioning our common habit (it is no method) of providing school facilities. We are perfectly well aware that our communities are growing; we are not permitted to overlook the fact. We are duly impressed by population curves, their trends closely approximating curves of compound interest, showing that local immigration and a normal birth rate add to our numbers from three to seven per cent, or even more, each year. We realize that our most virile immigration and our best citizenry are among those who have given hostages to fortune, and we welcome their happy children. Yet what do we do for these children in the way of decent, adequate, and appropriate school facilities? We put them on a waiting list.

Yes, of course, we give them desk room somewhere meanwhile, but in places which are admittedly makeshift and temporary, or in buildings waiting to be torn down. For while we can calculate almost to a nicety the yearly increase of our school population, we make no reasonable and proper provision for this increase and are almost always years behind. When our neglect has finally become flagrant enough, we indulge in a virtuous spasm of school building, nicely calculated to relieve the shortage, and which, when it subsides, invariably



MISS BURKE'S SCHOOL, SAN FRANCISCO
Julia Morgan, Architect

leaves us again about two years behind. If the building project is vast enough, we may create a municipal architectural bureau to handle it, which ordinarily begins to function successfully when its work is about done—and then suffers complete disruption.

Most of our shortcomings and ineptitude in this direction are chargeable directly to our common and mistaken financial policy, for the provision of school facilities must necessarily follow the provision of funds. Since the yearly, progressive increase of the school population can be readily foreseen, so also can the cost of accommodating that increase, and of necessary replace-

ments, be readily foretold in terms of land, structure and equipment. This yearly recurrent cost the community should meet when, and not long after, the need arises; and if it cannot or does not, there is clearly something lacking with the community and with the civilization which it boasts. Yet, what is the almost invariable practice? It is practically to ignore the only immediate and timely resource of the community in direct taxation (which, while more or less inadequate under our law, is yet considerable), and to depend entirely upon the grudging, doubtful and occasional grace of the community in voting school



MISS BURKE'S SCHOOL, SAN FRANCISCO
Julia Morgan, Architect

bonds. Having gone into this subject sufficiently elsewhere, and having demonstrated the fallacy of recurrent borrowing both in theory and in practice, I shall merely repeat here that this policy only persists by reason of our low standards in social ethics, responsibility and general intelligence. And one is not in second-rate company with this conclusion.

Our financial policy in providing schools and schooling should not only be sanely consistent, it should be far more liberal and enlightened as well. This is an ancient and uninteresting story, yet the prevailing high cost of living and

of building (or the new price level, as one prefers), and the distressful wail of the long-suffering educators, give point to some serious reflections upon the apportionment of our educational largess. While admittedly starving our teachers, are we over-architecting our buildings? Or are we not downright stingy with both? In adding value to raw materials, in industry, it is commonly observed that the higher and more refined the finished product, the greater has been the expenditure for wages, and the less, relatively, for mere building shelter. Unhappily for the teaching profession, this certainly has never applied in adding value to the human product. Nor is the present tendency in that direction. On the contrary, our expenditures for school buildings, grounds and



MISS BURKE'S SCHOOL, SAN FRANCISCO
Julia Morgan, Architect

equipment have increased far more rapidly in recent years than expenditures for teachers' salaries. Disproportionate outlays are apparently being made for school shelter, even oftentimes to the point of close and unnatural confinement, while fundamental needs have taken second place. It is a sad and curious irony that our disparaged but triumphant materialism should so suck the life out of our puny idealism in the very cradle of the nation! Better salaries, and more teachers—far-fetched as that may seem—will go far indeed to elevate the true standards of school architecture.

The facility of building and financing our schools naturally varies greatly with their size (inversely, one may say, if mathematically inclined), and consequently with their dispersion in the school community. This suggests another fruitful field of inquiry which I believe has never been sufficiently explored. We have

in fact been callous to considerations that should be paramount in determining the size, character and service radii of our school units, more especially as to our children in the beginning grades. In our obsession for economy we have exalted considerations of secondary importance, adopting into our school system all the idols of big business—organization, administration, operative efficiency, standardization of product, quantity output, and so on—with such effect that the typical school plant needs no smoke stack to suggest a home of modern industry. The brute bigness, remoteness and general unhomeliness of such an institution make it no fit place for our youngest children, as those who have eyes to see can see. For, so far at least as the environment of these children



MISS BURKE'S SCHOOL, SAN FRANCISCO
Julia Morgan, Architect

is concerned (and excepting only our half-hearted recognition of the kindergarten), we have as generally and as wholly ignored all the beautiful, unquestioned precepts of the educational philosophers, laying them politely away, as Dr. Dewey remarked, as "precious portions of our intellectual heritage," and have herded our home-centred school babies indiscriminately with children of far different educational ages and stages.

Where shall we turn for light upon this special angle of the problem? It has been a common experience in the progress of democracy that real advantages of all kinds, those of education included, have been enjoyed by a fortunate or enterprising few long before they have been communized and shared by all the people. Free public education is itself barely more than a century old. Secondary and higher education are only now being democratized, and infant

education, at the foundation of the entire system, has flourished for years in private hands before attaining recognition and a permanent place in the public school. And it is in the legitimate extension and segregation of infant education, as still practically monopolized by progressive private enterprise, that we may now find ample inspiration and guidance. Certain intelligent parents and child lovers here and there, and from time to time, apprehending the beauties of kindergarten training, taking Froebel and other great apostles of childhood seriously (as our official educators would doubtless like to do), and continuing



MISS BURKE'S SCHOOL, SAN FRANCISCO
Julia Morgan, Architect

the benefits of their educational philosophy into the primary ages, have evolved a very delightful and informal type of centre which may best be described as the neighborhood school. The community is unfortunate that misses the example of this kind of school. In its intimate and effective social relations, its healthful and free atmosphere, its neighborly ease of access, its correspondingly modest size and its necessarily simple and domestic character, and above all in the surprising educational successes attained through the enlightened methods reflected in its gentle environment, the neighborhood school has fully justified itself in

practice as well as in long-accepted theory. It will presently be knocking, like the kindergarten, at the iron-bound portals of our public school system. For if this type of school unit has so clearly proved its worth for the fortunate few, why keep it from the children of all the people? As among the least of its possibilities, which are too varied to discuss here, it would provide at last the keystone for a rational system of distributing our community schools.

Such a system would promote a further much-needed reform in compelling seasonable attention to the need of building sites. Contrary to intelligent business practice, the acquirement of school sites almost invariably follows the need instead of anticipating it. The embarrassing but inevitable result is that land is found to be scarcest where most needed; local opposition is invited, if not actually aroused, and inflated, or at least established values are encountered. Even improved property occasionally has to be condemned. The process is thus all too frequently one of looking for something where it is not, accepting a compromise where it does not belong, and then paying too dearly for it; and it is very largely due to our practice of building at considerable intervals by the wholesale, instead of providing building and playground space where and when it is really needed. The segregation and dispersion of our school units as just now proposed would carve out a considerable portion of the building problem,



MISSION HIGH SCHOOL, SAN FRANCISCO
John Reid, Jr., Architect

divide that portion into small, easily financed and manageable parts, obviate the most burdensome waiting intervals and impose almost automatically a systematic prevision as to building sites.

There are, of course, many other and important considerations which should precede and largely determine schoolhouse design, and those just mentioned have been viewed only in their simpler aspects, without dwelling particularly upon their inter-relations. But enough has been said to remind us that our problems of providing, financing and distributing school facilities are of course only different aspects of our single great problem of community educational service; that there can be no consistent or tenable school building policy which is not the outcome and reflection of a consistent and thoroughgoing educational policy; and finally that the obligation of seeing this problem whole, and of visualizing for us our community educational ideals, lies with our Boards of Education and the trained executives in their employ. Unfortunately this obligation is not often well recognized or met, owing to various well-known human traits and limitations, and to the further handicap that the average school board is too loosely and inefficiently organized to reach any such fullness of purpose and service. Its worthy members plunge heroically into a maze of details, but they rarely ascend the heights, and are thus unable to see the forest for the trees.

Now I do not intend to disparage our public spirited school boards, nor to re-echo the strictures of the educational progressives and reformers; but I should like to point out how this situation reacts upon the architect and school architecture. The lack of a well-defined, consistent and continuous educational-building policy naturally tends to make a school board the most uncertain, irresponsible, and yet most exacting of an architect's clients. The board usually possesses no clear concept of such a policy, to which the requirements of new buildings may be helpfully referred, but it often does harbor a variety of points of view and of conflicting but positive convictions which must be harmonized. It inclines to important, but secondary details. It embodies the conventions



GRANT SCHOOL, SAN FRANCISCO
John Reid, Jr., Architect

and prejudices, as well as the aspirations of the community, and while it wants only the best, is naturally suspicious of anything new or unfamiliar. Its responsibility, as a usual thing, is not only divided but is well-nigh dissipated. The performance which an architect must necessarily go through under these conditions has gone far to cheapen and discredit our profession and to spread distorted notions of our service. And whether or not our school boards achieve coherent ideas and purposeful organization, it is surely incumbent upon us to see that our professional relations to these bodies are plainly and adequately defined.

The scope of our service should first be delimited and understood, not in the usual hackneyed words, but in terms relating our profession broadly to

the society we are presumed to serve. As I have tried to indicate, a school building program is not a mere list of required spaces and utilities, it is part of a community-wide educational program, without which no single school enterprise can be completely intelligible. It is clearly within the architect's province therefore to share and understand that wider program and to cooperate in translating it into the everyday terms of building structure. To that extent, at least, it is the architect's professional duty to do not simply as he is told, but to tell his clients what to do. Occasionally the architect is permitted to round out this service and is entrusted primarily with the creation of a community's building scheme as a reflection of its educational policy and ideals.



HARRISON SCHOOL, SAN FRANCISCO
John Reid, Jr., Architect

This is not beyond the resources of the duly qualified educational architect, though it multiplies his responsibilities, leads him into social and economic fields and broadens his work to the art and science of community planning, of which educational planning is the one most significant phase. But a confidence of this kind is not to be accepted lightly, or merely as a means to personal advantage. Such an undertaking is sure to fail without sufficiently wide and skilful co-operation, and valid conclusions cannot usually be reached without a thoroughly and necessarily laborious community survey. Can the architect's service be expanded successfully over this wide field? That, of course, is a question of more than technical and artistic skill, or the usual fruits of formal architectural education; it is a matter of far greater breadth and wider powers, and of a social-economic sense which must be informed and cultivated if architects are to furnish more than mechanical aid to education or any other interest in life. Let each architect then search his own conscience as to the extent of service he

may render; but let it be known at least that our field of professional interest is wider than drawings, specifications and contracts, and that these mere instruments of our service cannot embody a structural ideal unless a far wider ideal has first been formulated and put in our possession.

Whether or not we are accorded—and earn—this much professional recognition by the school board, we must secure a full and fair definition of our business relations. Here is an urgent need for reform, for the still popular confusion of architects with contractors puts us into impossible situations. It persists in the wording of our school law, which may be searched in vain for the word “architect,” and which, to the uninitiated, conveys the absurd impression that an architect may not be compensated on the basis of services duly ordered and rendered, but only upon work which the board and the community elect to carry out. As if the physician should not be paid for diagnosis and prescription, unless his patient chooses to swallow the pill! But this is only one of a dozen defects which must be removed. Why should we not dispose of them all at once, and without further unnecessary delay? This can be done, I believe, and the drawbacks of school practice minimized, through a State-wide form of contract for school architecture. The endorsement of such a contract form by our State educational authorities and its currency among school circles would go far to improve our professional standing, not only with school trustees but with the general public as well. We have in California a State Bureau of Architecture, two Chapters of the American Institute of Architects, and doubtless other architectural bodies, dead or alive. Among us all we can surely evolve and perfect such a form of contract, secure its endorsement by the State Board of Education and endeavor to have it generally recognized.

In making these protests in behalf of the architect employed by school boards, I am, of course, presupposing an important something on his part. Is the architect of a school, or even of many school buildings, by that token a school architect? And is that esteemed title otherwise to be sternly denied? No, I say; for the true distinction is to be found, not in impressive technical knowledge and experience, but in the definition of architecture as an art. As an art, architecture must appeal positively to the spirit, not merely to the physical needs of man; and unfortunately it too often misses his nobler side and reflects only his vanities and sophistications. But school architecture then should appeal all the more clearly to the simpler spirit of childhood and youth, and should realize to the fullest extent possible “the environment suited to their nature.” One refrains from enlarging upon this theme, and despairs of having it taken seriously in our cynical adult world, when, in a recent issue of the Architectural Forum, a schoolhouse is defined as “a contrivance to protect children from the inclemency of the weather while they are being educated.” Shades of the whole noble army of educational philosophers! Turning back six years in the *Architect and Engineer*, I find I have already defined school architecture as “solely concerned with making schools supremely fit for children.” Measured by this test of creating expressive and appropriate school environments, it is not at all invidious to assert that school architects are few and not invariably well known, and that the vast majority of schools are designed by mere school builders. At the opposite extreme of high and devoted professional service, we may some day find more than a few who will qualify in the well-rounded, comprehensive way that I have already described, and will thus serve society as true Architects to Education.

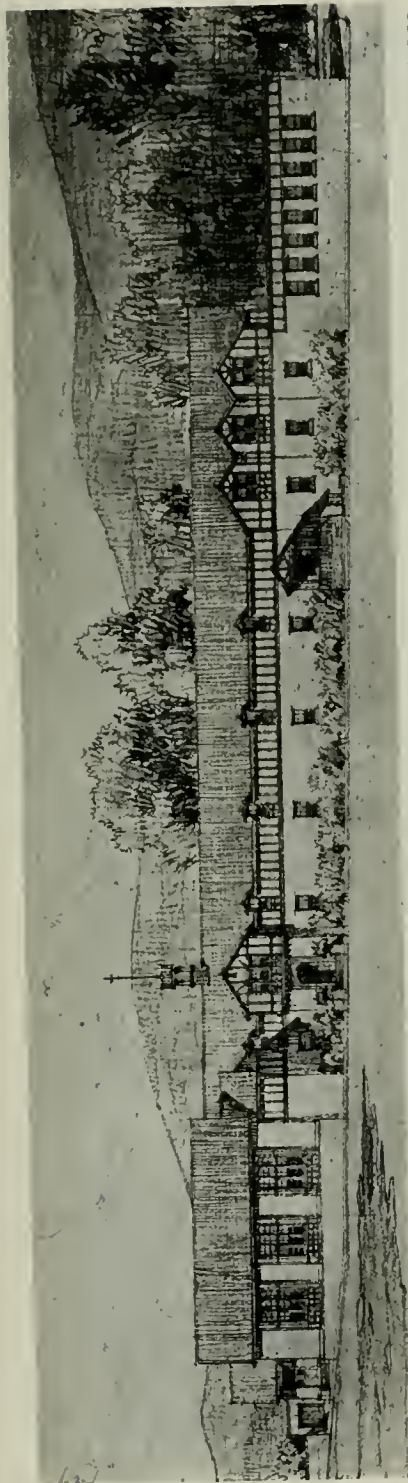

PARKSIDE SCHOOL, SAN FRANCISCO
JOHN REID, JR.,
ARCHITECT

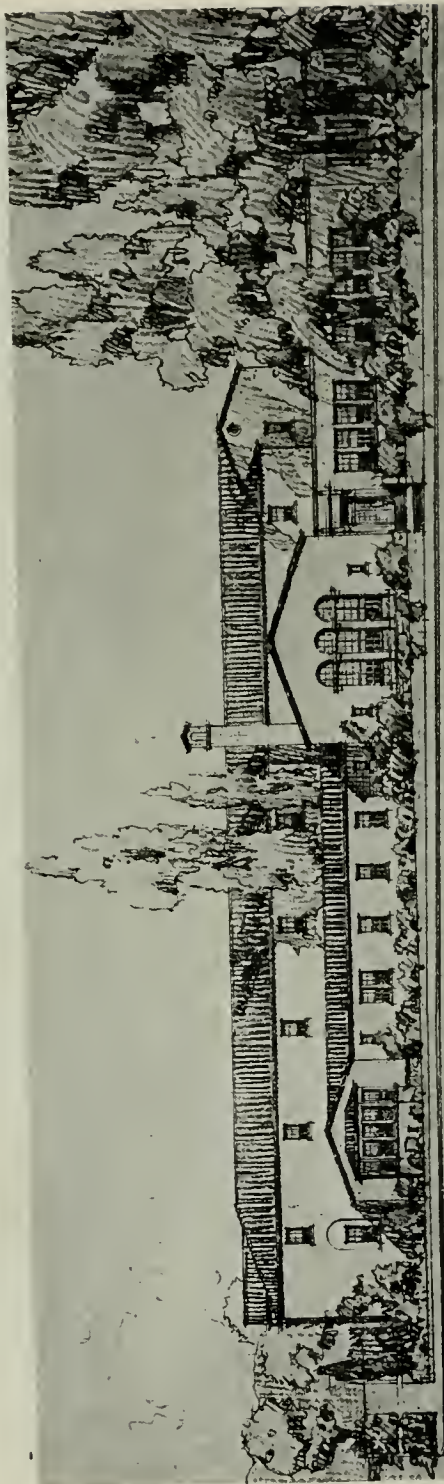

COMMODORE SLOAT SCHOOL, SAN FRANCISCO
JOHN REID, JR.,
ARCHITECT

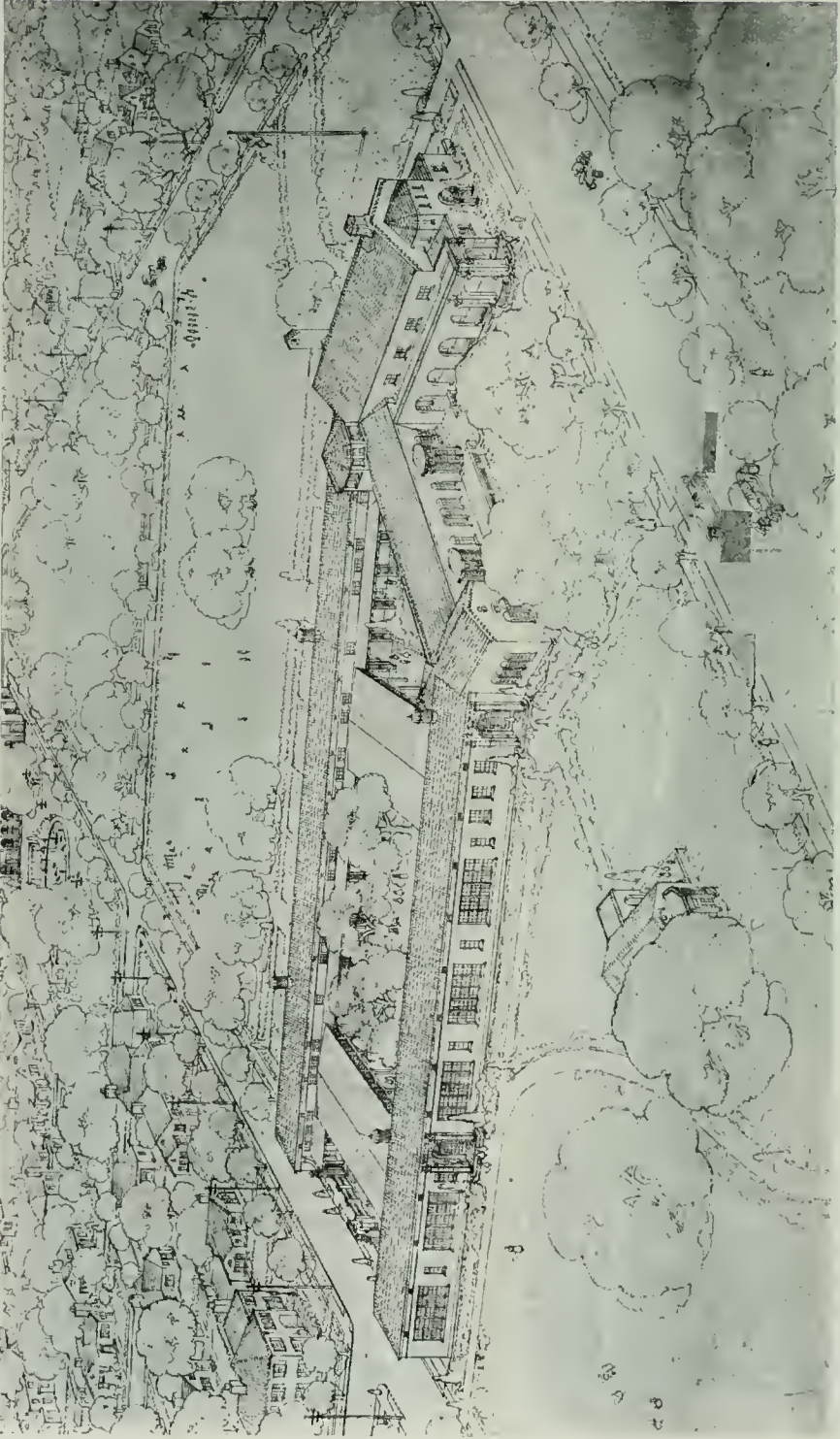

ELEMENTARY SCHOOL, PALO ALTO, CAL.
CHAS. K. SUMNER, ARCHITECT
WM. C. HAYS, CONSULTING ARCHITECT

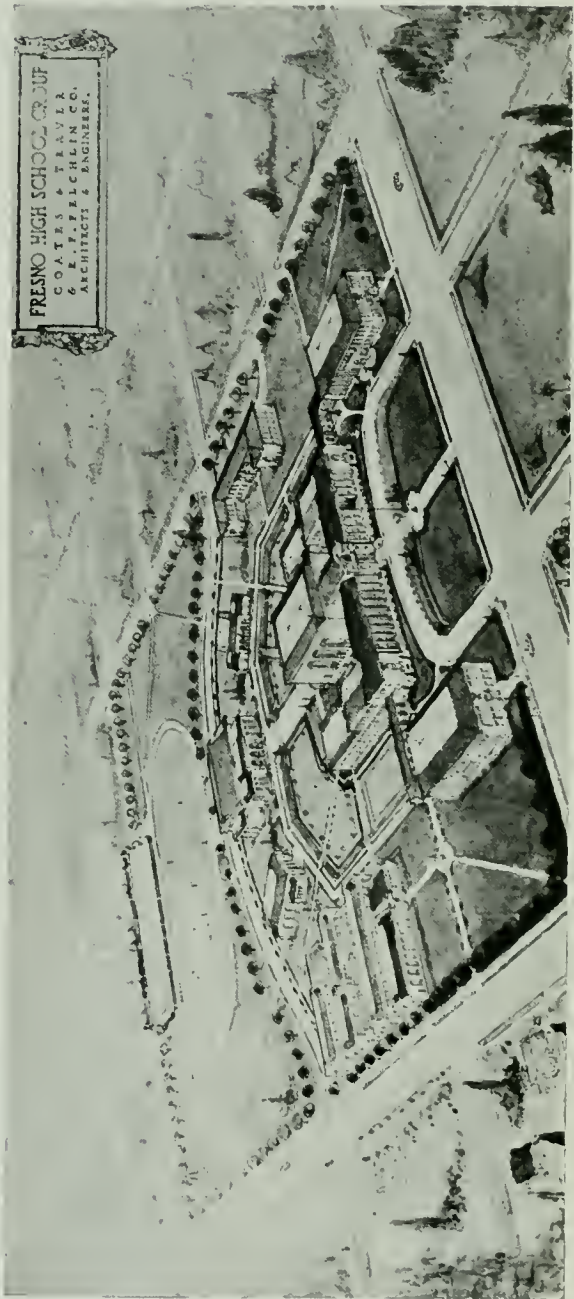
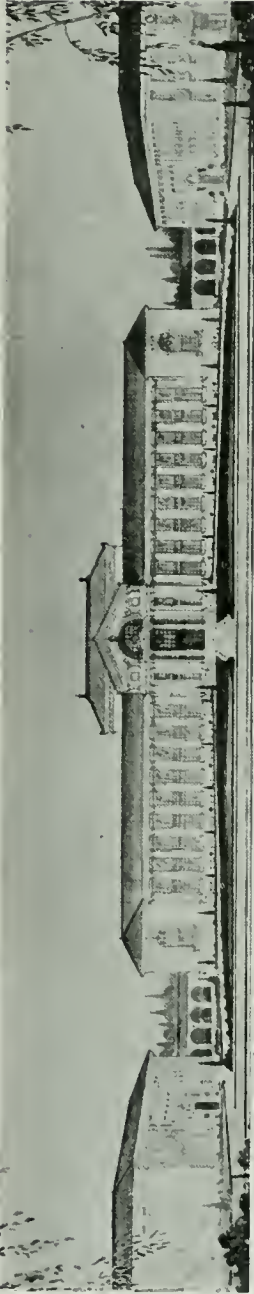

FRESNO HIGH SCHOOL, FRESNO, CAL.
COATES & TRAVLER AND R. F. FELCHLIN
CO., ARCHITECTS AND ENGINEERS



PERALTA ELEMENTARY SCHOOL FOR
 GIRLS - 1904
 PREPARED BY THE COMMISSION
 DEPARTMENT OF THE BOARD OF
 EDUCATION - OAKLAND CALIFORNIA

ELEVATION FROM NORTH STREET
 SCALE 1/8" = 1'-0"

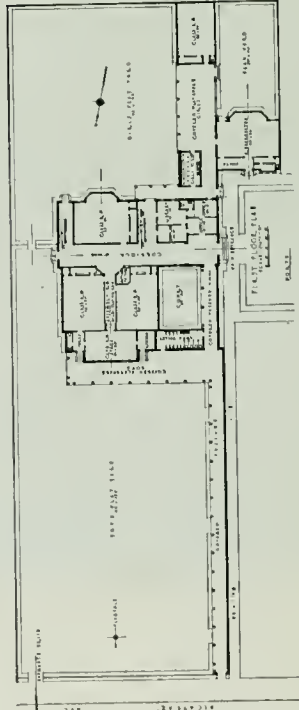

FIRST FLOOR PLAN

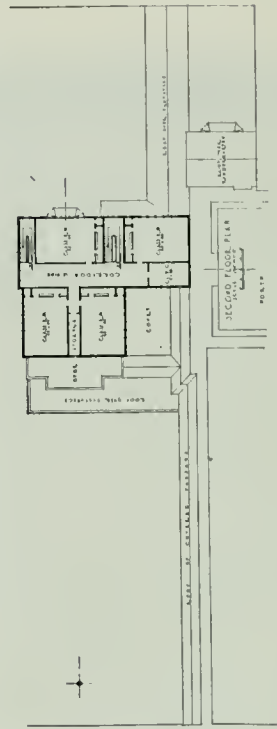

SECOND FLOOR PLAN

PERALTA ELEMENTARY SCHOOL, OAKLAND, CAL.
 Construction Department of the Oakland Board of Education. Marston Campbell, Chief of Construction; C. W. Dickey, Supervising Architect.

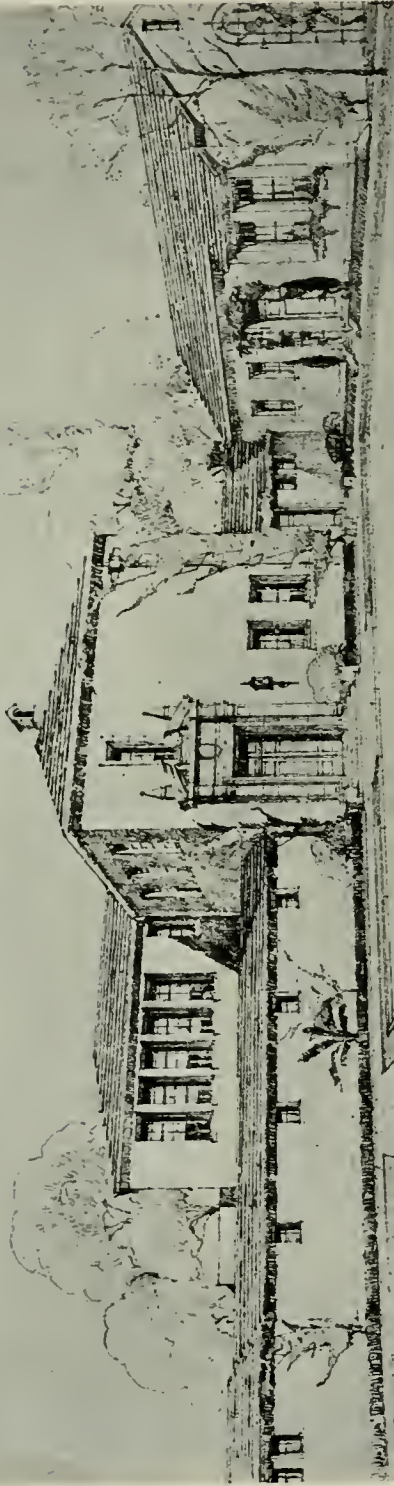

PERALTA · ELEMENTARY · SCHOOL ·
 · ALCATRAZ · AVENUE · AND · NORTH · STREET ·
 · OAKLAND · CALIFORNIA ·

· MARSTON · CAMPBELL ·
 · CHIEF · OF · CONSTRUCTION ·

· C · W · DICKEY ·
 · SUPERVISING · ARCHITECT ·

PERALTA ELEMENTARY SCHOOL, OAKLAND, CAL.
 Construction Department of the Oakland Board of Education. Marston Campbell, Chief of Construction; C. W. Dickey, Supervising Architect.

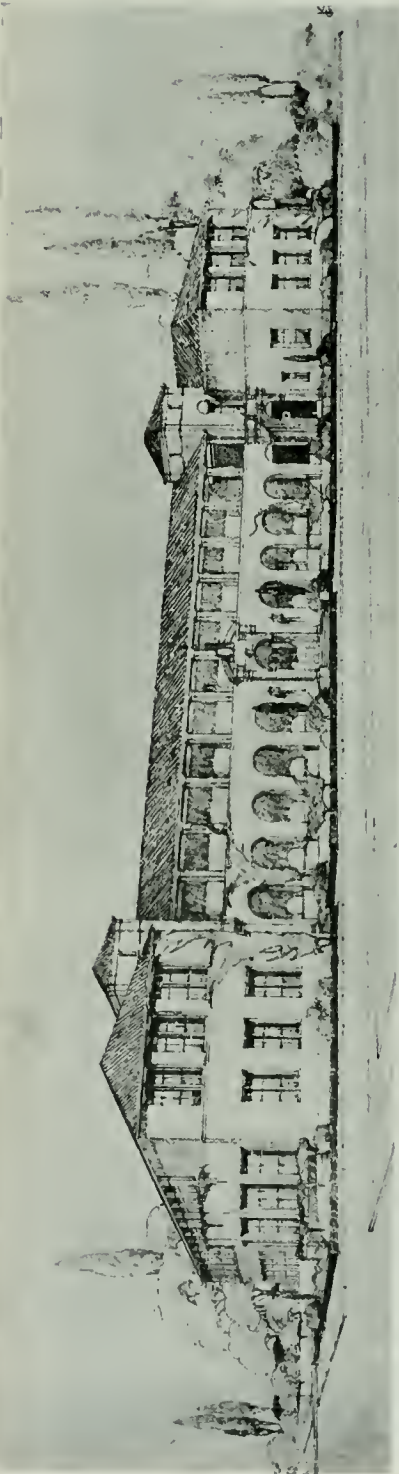

STUDY FOR AN ELEMENTARY SCHOOL

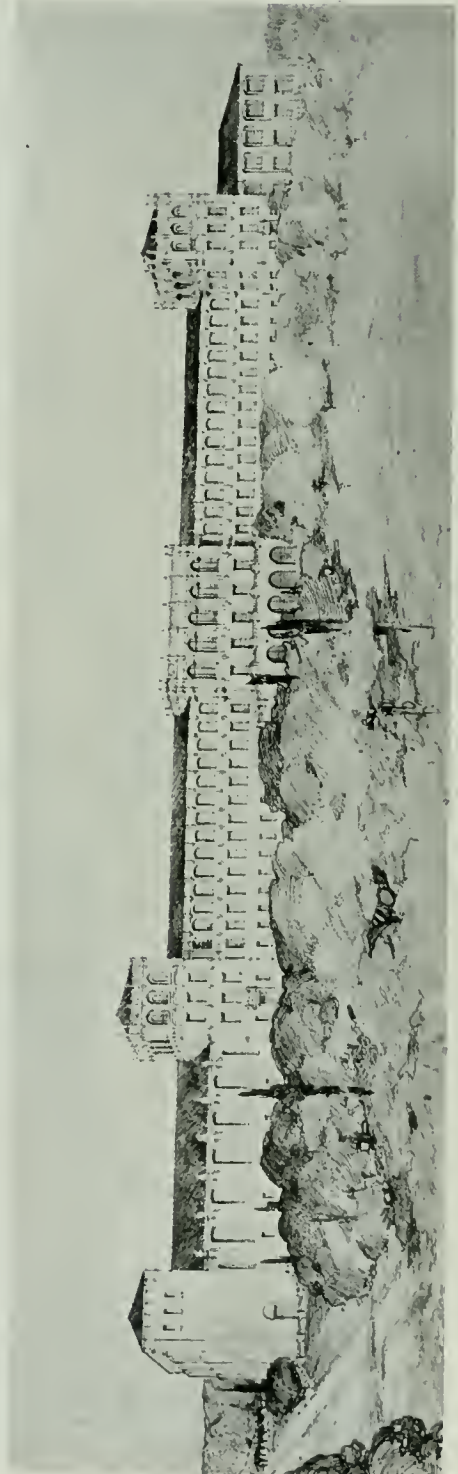

STUDY FOR A HIGH SCHOOL

Construction Department of the Board of Education, Oakland, Cal: Marston Campbell, Chief of Construction; C. W. Dickey, Supervising Architect.

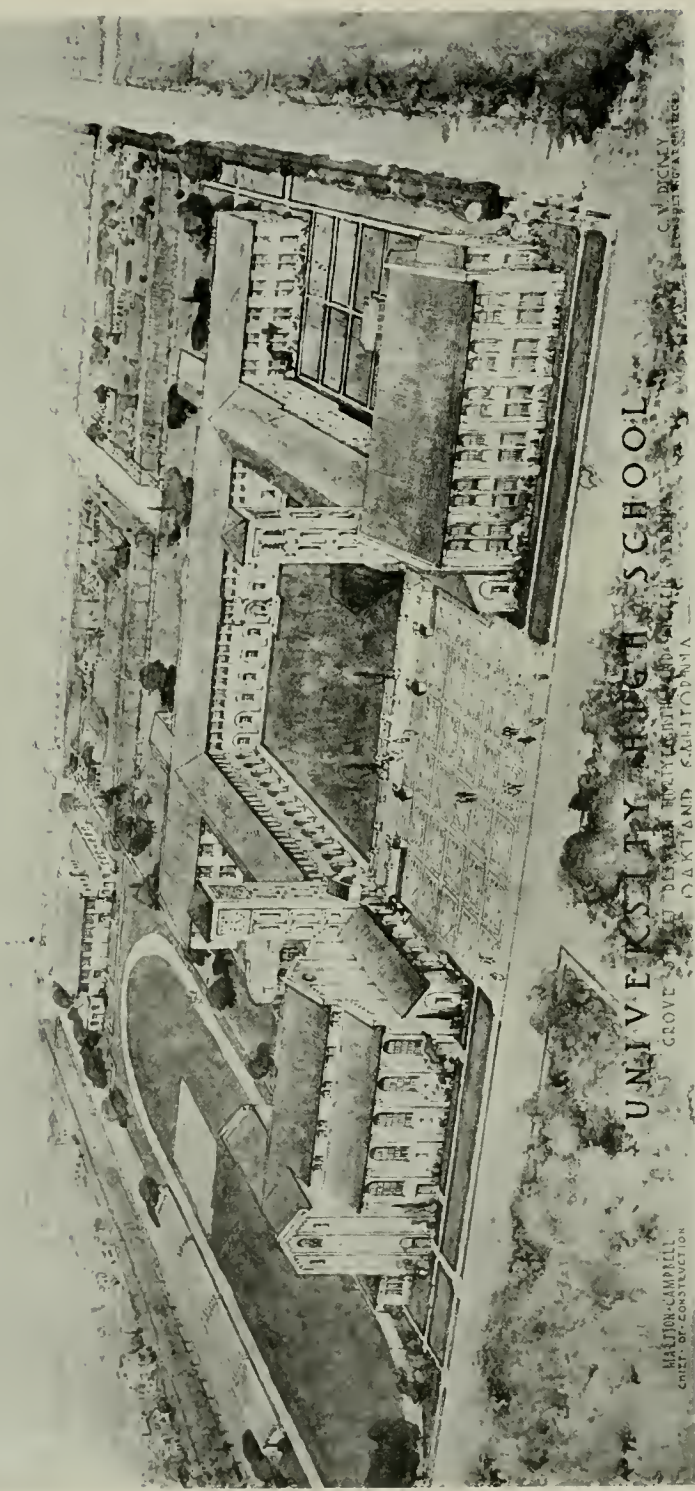

UNIVERSITY HEIGHT SCHOOL
GROVE STREET, OAKLAND, CALIFORNIA

MARLTON-CAMPBELL
CHIEF OF CONSTRUCTION

C. W. DICKEY
SUPERVISING ARCHITECT

STUDY FOR A HIGH SCHOOL (ABANDONED)
Construction Department of the Board of Education, Oakland, Cal. Marlton Campbell, Chief of Construction; C. W. Dickey, Supervising Architect.

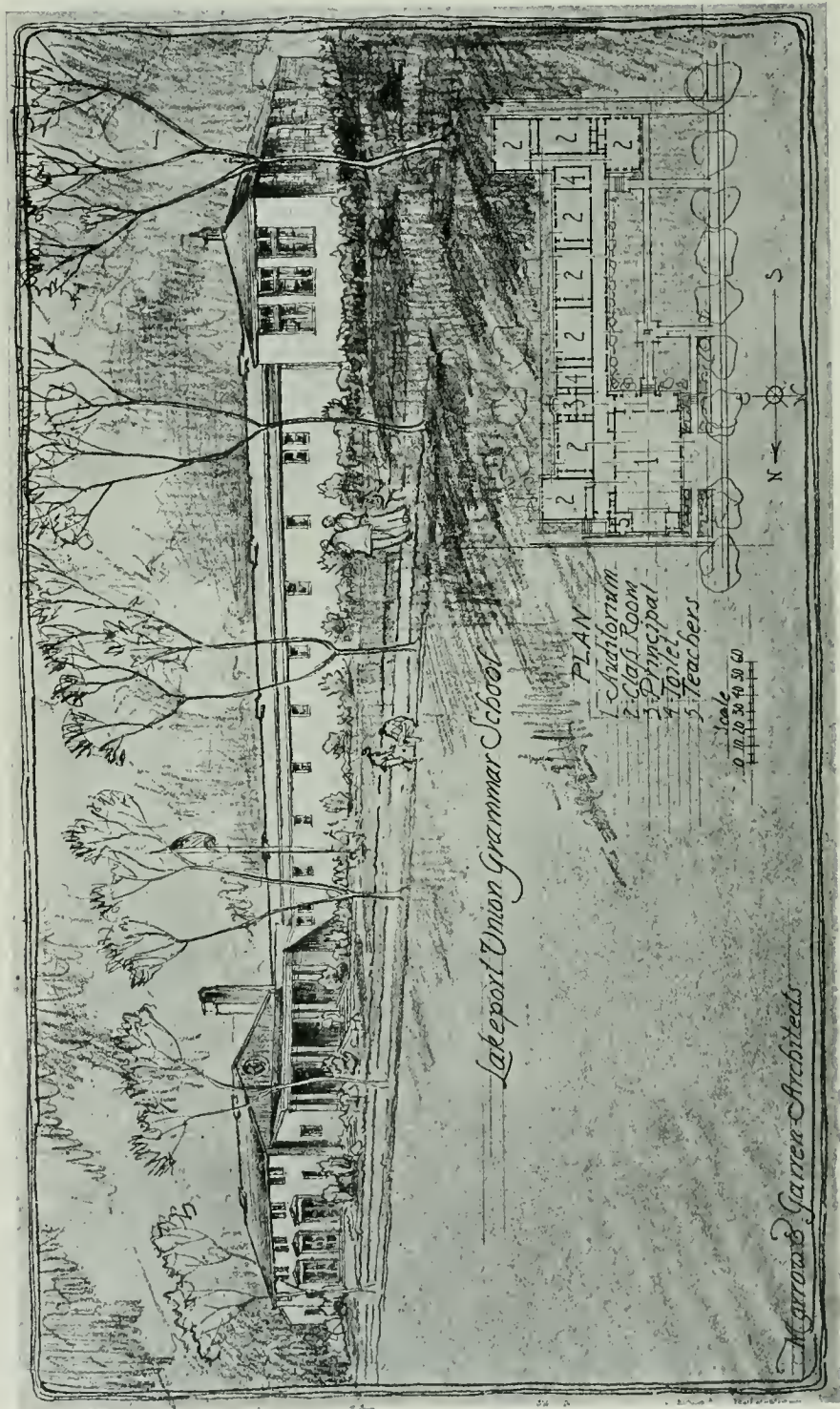

LAKEPORT UNION GRAMMAR SCHOOL, LAKEPORT, CAL. MORROW & GARREN, ARCHITECTS

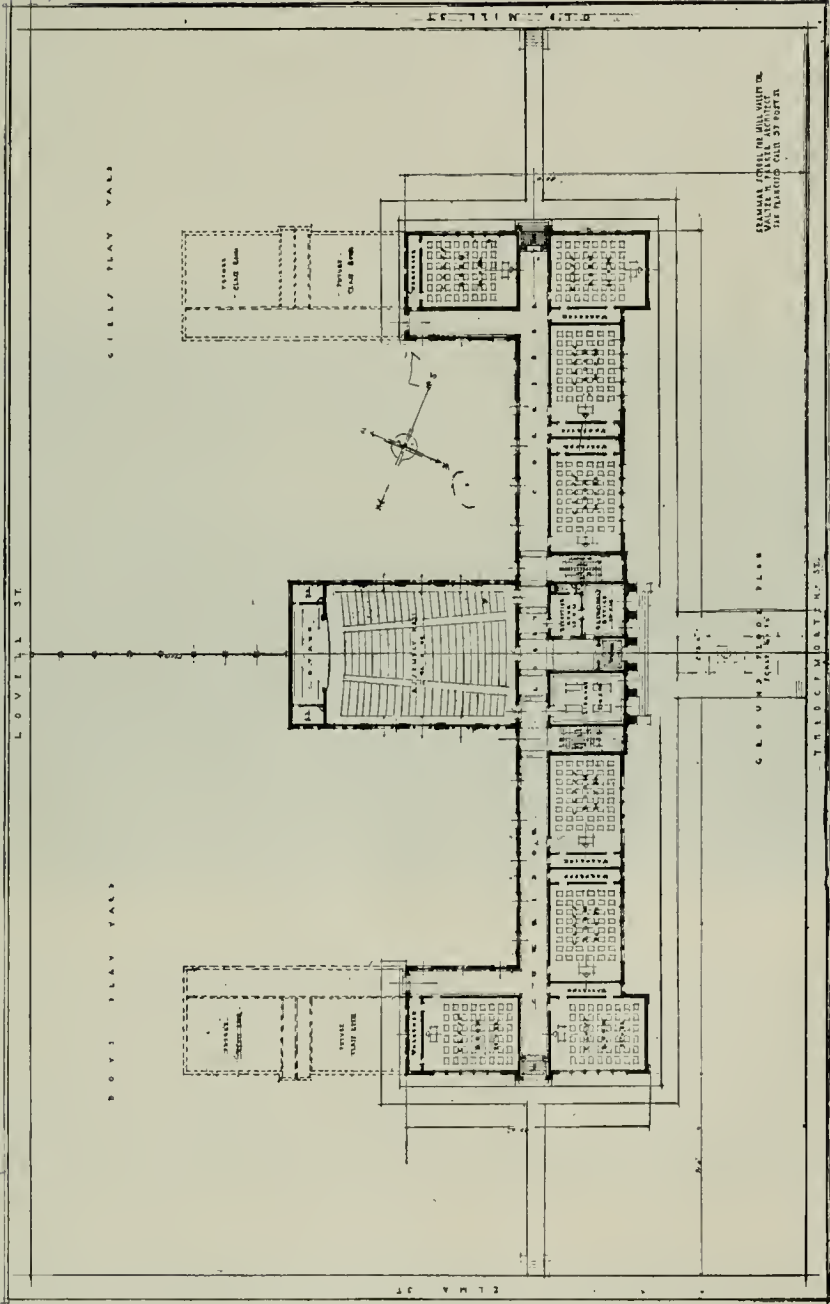

GRAMMAR SCHOOL FOR MILL VALLEY, CAL.
 WALTER H. PARKER, ARCHITECT
 100 BALBOA BLVD. S.F. 94114

GRAMMAR SCHOOL FOR MILL VALLEY, CAL.
 WALTER H. PARKER,
 ARCHITECT

(See next page)

Architecture, Planning, and Construction of Schools*

By JOHN J. DONOVAN, Architect, A. I. A.

THESE is nothing more impressive or hopeful in American democracy than the devotion of the people to education. Nor is this devotion confined to those who have enjoyed its enrichments. Even in the humblest homes unlettered parents will be found to have a fixed desire for the educational welfare of their children. Sacrifices in personal comforts of all but the means of mere existence are made in order that the family may have the opportunity of receiving not simply the fundamentals of learning, but the training of the university as well. And the devotion of the wealthy is no less impressive. For the great progress of education is due in large measure to the interest in education shown by men and women of affluence. Universities, colleges, academies, and often the public schools could not have fulfilled the educational wants of

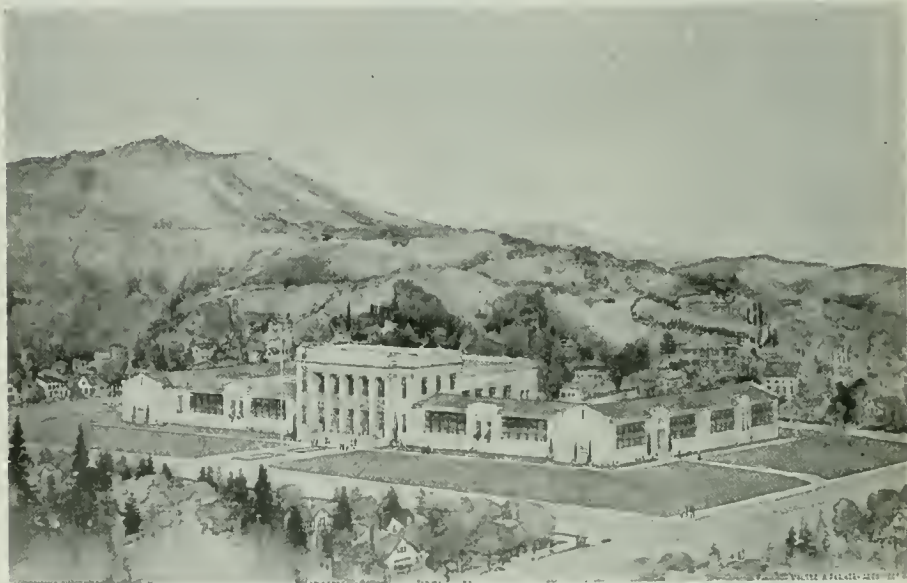

GRAMMAR SCHOOL, MILL VALLEY, CAL.
Walter H. Parker, Architect

the nation, had it not been for the many magnificent endowments for the promotion of learning and the development of character, placed at the disposal of education by these public-spirited people.

Education is the common meeting-ground for all classes, creeds, and races, where the small bothersome misunderstandings of life vanish; and nowhere is this more evident than in American school life. The greatest tribute of justice that can be paid to the nation is that its laws first demand that its youth shall receive the fundamentals of education, and then it presents the widest opportunities for its humblest citizen and resident to proceed in acquiring unlimited learning.

With such a foundation, it is no wonder that the architecture of American schools and institutions of learning has advanced more rapidly than that of any other field of the profession. Unconsciously the spirit has been to represent

*This article consists of advance proofs of Chapter II of Mr. Donovan's book, *School Architecture*, to be published shortly by The Macmillan Co., New York.

truly this national devotion to education in the architecture of public schools. If progress in education is observed from the time when it was dispensed within the small box-like building, with its poorly lighted and badly ventilated rooms, to its present expanded and still expanding status, as carried on within the modern complex structure completely equipped and embracing all facilities for education, health, and safety, it will be seen that architecture has kept abreast with each succeeding step of the educational program, in which the course of studies has become more and more extended to meet the requirements of the industrial, commercial, and social life of the nation.

Notwithstanding this expansion of the curriculum and the consequent complexity of the building and equipment, it is gratifying to note that the architecture of the school has remained simple and direct. This is truly a hopeful sign. For as the nation advances in its development and maintains its virility, the demands for education will always outstrip the supply. And the burden of taxation so willingly borne as a responsibility to posterity and good citizenship is that much lightened when the merit of the architecture is based on good



SCHOOL FOR MADERA, CAL.
Walter H. Parker, Architect

planning, beauty of form, and dignity of proportion. Ornamental embellishments serve no purpose. They do not represent the character of the school or of the people, and happily their use is rare in American school architecture. Just how much credit for this is due to the influence of the work of Wheelwright, Ittner, Snyder, Perkins, Naramore, Hussander, Austin, Guilbert, Betelle, Packard, the Allison's, and to the innumerable others who have contributed isolated examples, and to the influence of the broad-minded, alert, and discerning leaders of education, is difficult to measure at this time. But it is recorded in their examples of school architecture that these men, by their serious study of the problem and their good sense for simplicity in composition, have led the way in school architecture toward possibilities which have clearly exemplified the people's devotion to education and their appreciation for simple, substantial structures.

FORMATION OF THE PLAN

The proper understanding of the school problem might be said to have passed its first stages. While what has been accomplished in the last two decades has been remarkable, it will be greatly surpassed in the future. With a comprehen-

sive knowledge of the pedagogical organization being more generally acquired by the architectural profession, the prospect is bright for good planning of school buildings. There is an axiom in the science of building that a good plan should produce a good exterior. This, of course, is subject to the limitations of training, skill, taste, and competence of the architect. But it is none the less true that the plan must be of primary importance. The correlation of rooms within each department and the correlation of departments within the school is all-important if the school is to permit of being well administered. In factory planning, the essential factor is the routing of material along the most direct and economical channels. In school planning, the routing of the human material is the essential. Rooms which can serve more than one purpose should be planned to do so. For it is by such practices of economical planning

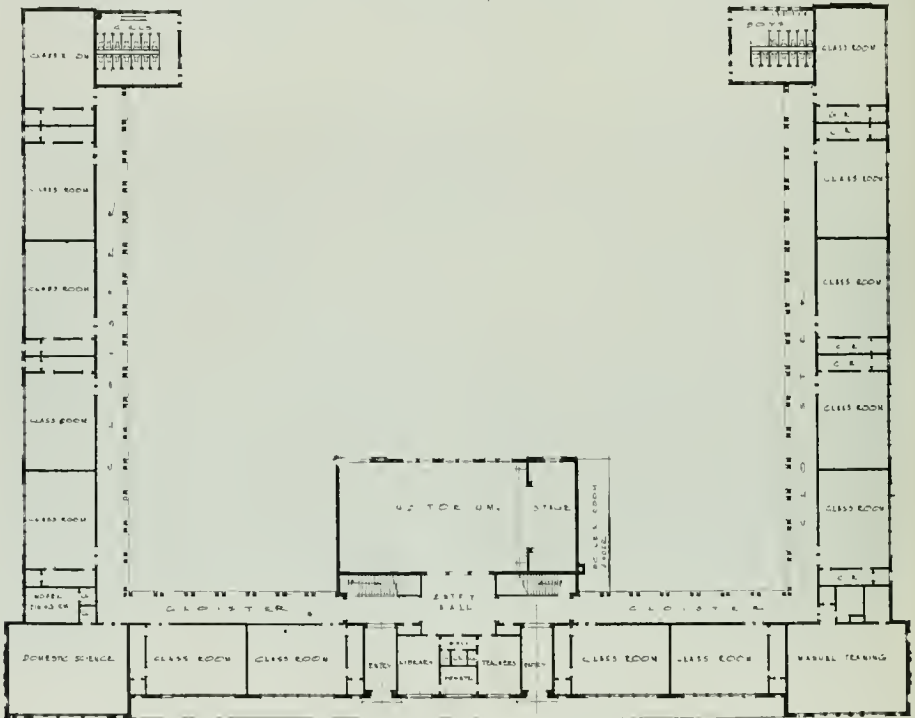

STEGE SCHOOL, RICHMOND SCHOOL DISTRICT, CAL.
Jas. T. Narbett, Architect

rather than by the use of cheap materials that real economy can be accomplished.

Within the last decade there has been a strong tendency to link the school and the community together by providing separate rooms for community purposes, such as clubrooms, small libraries, etc. This movement is accomplishing its purpose, for out of it is growing a valuable connection, namely, the parent-teacher association and the continuation school. The close relation between the school and the community must be fostered if education is to prosper; but instead of devoting valuable space in the building for occasional use, rooms such as the teachers' rest room, the library, the assembly hall, or the music rooms should be the meeting places of the community clubs.

Every facility should be made for educational work, and every dollar spent should have its worth expressed in the educational, hygienic, and structural

features of the building. When it is considered that even with the strictest economy in planning only fifty per cent of the total floor area can be used for instruction while the other fifty per cent is used for corridors, stairways, entrances, and rooms and areas related to instruction rooms, it is evident that judgment must be exercised in giving up space for other than that for direct instruction. This, however, should not prejudice the reader against such rooms as assembly halls, swimming-pools, playrooms, etc., for these are just as essential to the development of the child and the community as the classrooms themselves. The school of the future will not be complete without them; but their location with relation to each other should be planned to avoid duplication of equipment and plant. For instance, the toilets, showers, dressing-rooms, etc., for the play-yard activities should also serve for the swimming-pool, the gym-

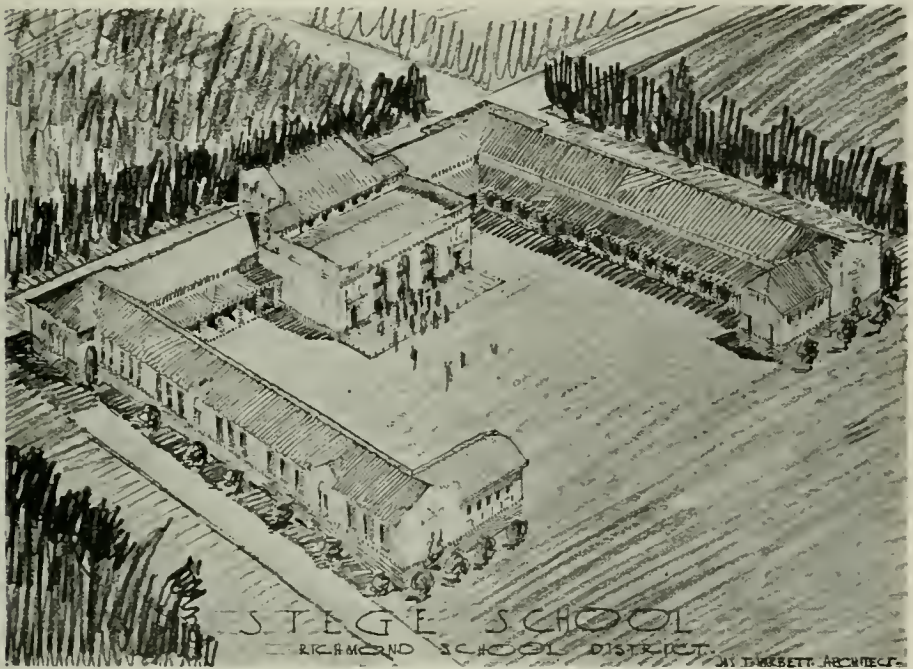

STEGE SCHOOL, RICHMOND SCHOOL DISTRICT, CAL.

Jas. T. Narbett, Architect

nasium, and the indoor playrooms. The dressing-rooms for the assembly-hall stage should be planned for use by the music department for private instrumental instruction. In fact, all the rooms throughout the school should be considered as having possibilities for extended use into school activities beyond their primary purpose.

The plant and equipment of the day school must be fitted and adapted to the work of the continuation school, so that rotation of students may be accomplished without friction or waste of time or energy. In many cities the continuation school periods begin at 1 p. m. and extend to 10 p. m. It is not unlikely that the hours of work for this branch of school education may extend from 7:30 a. m. to 10 p. m. Students enrolled in the continuation school enter and leave the building at all hours, consequently the plant should be as flexible as the organization in meeting the requirements.

CORRELATION OF DEPARTMENTS

The various departments of the school are treated in separate chapters because of the importance of having correct and definite data embracing their organization, planning, and equipment. Their correlation only will be discussed here.

It will be found advantageous if the commercial department is placed near the administration offices, as they have much in common. The shops should be isolated from the study and recitation rooms, on account of the noises attendant to their operation. The drawing department should be near the shops, as all advanced shopwork should be performed from working drawings. If these two departments are adjacent, convenience will result. Possibilities for wide expansion should always be made feasible in planning for shops. The household arts and the science departments should also be near each other; particularly should the chemistry laboratories be available for use by the students in

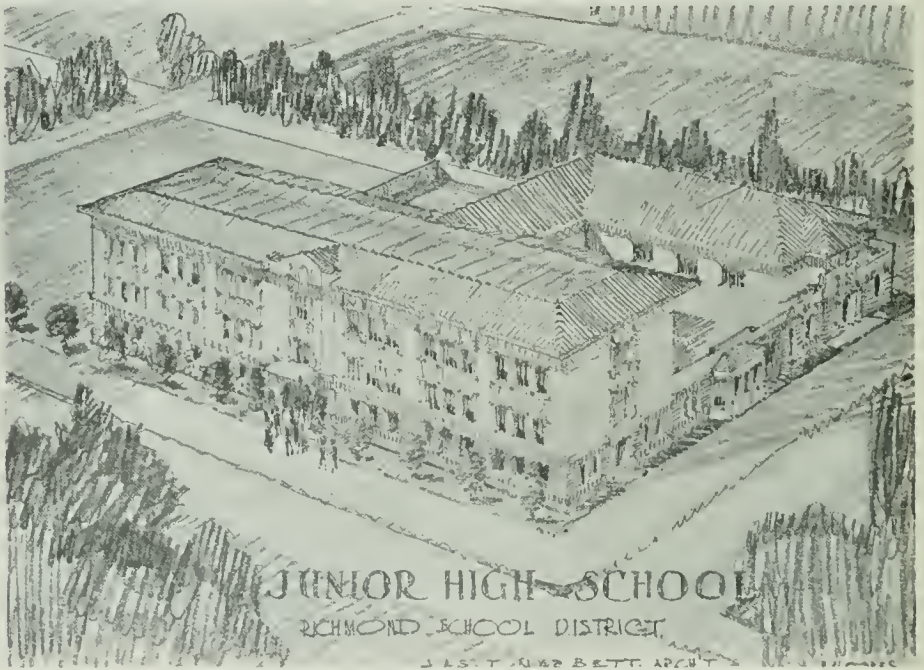

JUNIOR HIGH SCHOOL, RICHMOND, CAL.
Jas. T. Narbett, Architect

cooking. The chemistry of foods is a part of the curriculum of household arts in modern high schools. The academic department and the library are almost a unity, and wherever located, possibilities for expansion and easy growth should be considered from every angle. For as enrollment increases, this department is the first to feel congestion. Locating the assembly hall, the gymnasium, the swimming-pool, the showers, and the play-yard accommodations should have reference to free accessibility by the public. These divisions of the school plant should be arranged so that if found desirable or necessary, the remainder of the school may be closed off. As a general rule, the heating plant should be closely connected with the shops and apart from the main building. This will serve a double purpose in providing certain instruction to the student in mechanical installations and at the same time increase the safety of the building and its occupants.

PLANNING THE SCHOOL OF THE FUTURE

The school of the future, having the last decade of progress in education for its foundation, will have to be proportionate in plant and equipment to meet the needs of each community for the great post-war period of education. The physical and scientific requirements of the great war (1914-1918) have precipitated a feeling for an intense and constructive movement for greater diffusion of educational training in the professional, social, industrial, and commercial fields of endeavor. Business, industry, agriculture, and the other arts of

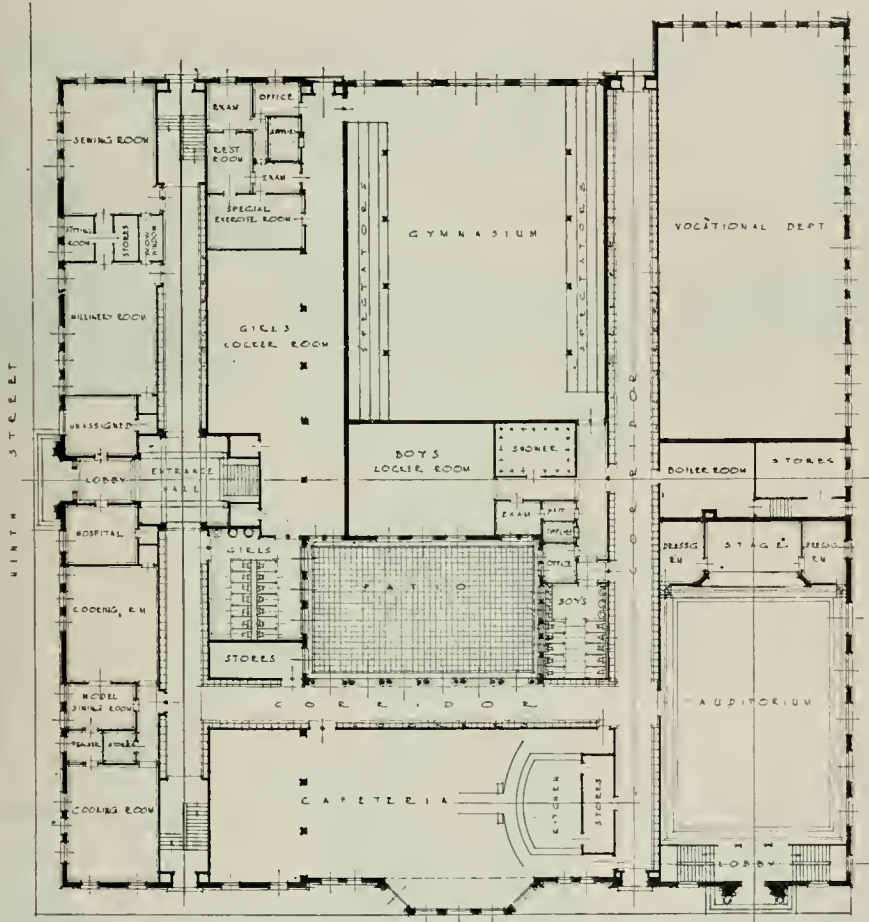

BISSEL AVENUE
 JUNIOR HIGH SCHOOL, RICHMOND, CAL.
 Jas. T. Narbett, Architect

(See next page)

life are no longer independent of the school. Nor is the school an isolated institution, occupying a definitely limited period in the life of the individual. That belief now lies in the background of the history of both education and industry. Research and applied science have received an impetus never before experienced or equaled, an impetus which gives to these two important branches of education a higher standing of importance.

It is also through the school that the more complete nationalizing of the immigrant and his children will be brought about. This movement is well under

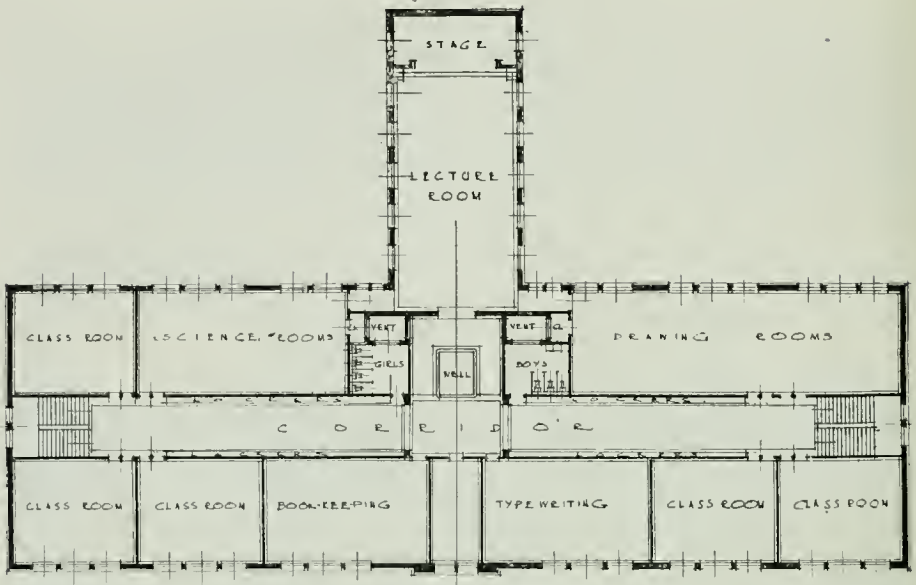

NINTH STREET
THIRD FLOOR PLAN

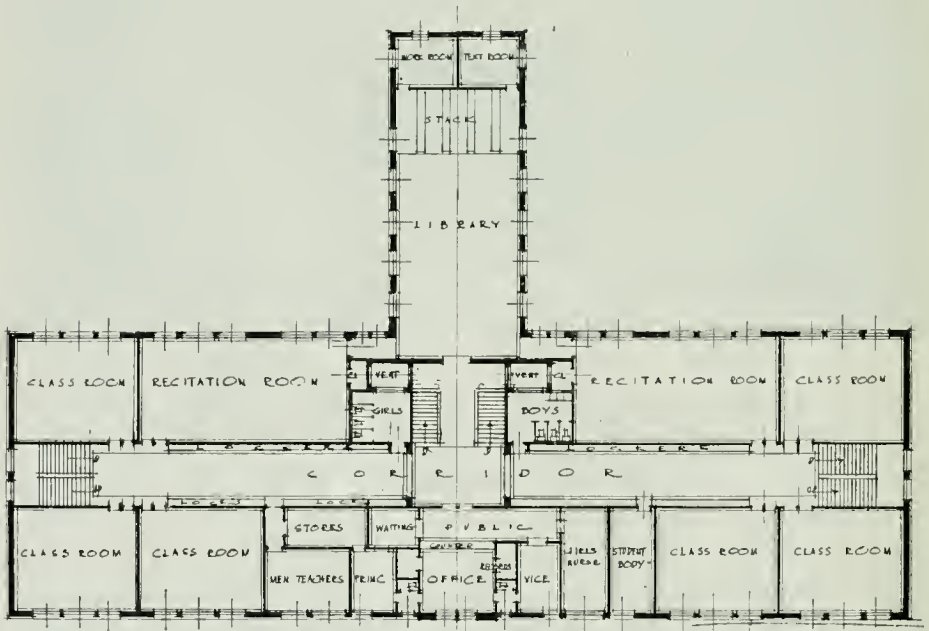

NINTH STREET
SECOND FLOOR PLAN

JUNIOR HIGH SCHOOL, RICHMOND, CAL.
Jas. T. Nabett, Architect

(See previous page)

them as shops or laboratories. Each room, before the drawings have passed beyond the preliminary stages, must have its equipment carefully shown, properly located, and tested in the abstract for efficiency and adequacy.

Attention should be called to what all this means in the planning and architecture of the school of the future. Undoubtedly, the high school will take on the aspect and character of the university, and function for the community as the university now functions for the State. Instead of many small and distinctly exclusive high schools, such as the classical, the commercial, the technical, the vocational, etc., etc., the people and their representatives, boards of education will see the light of wisdom and group all these separate schools under one, two, or three plants, according to the size of the district or city. This will make for

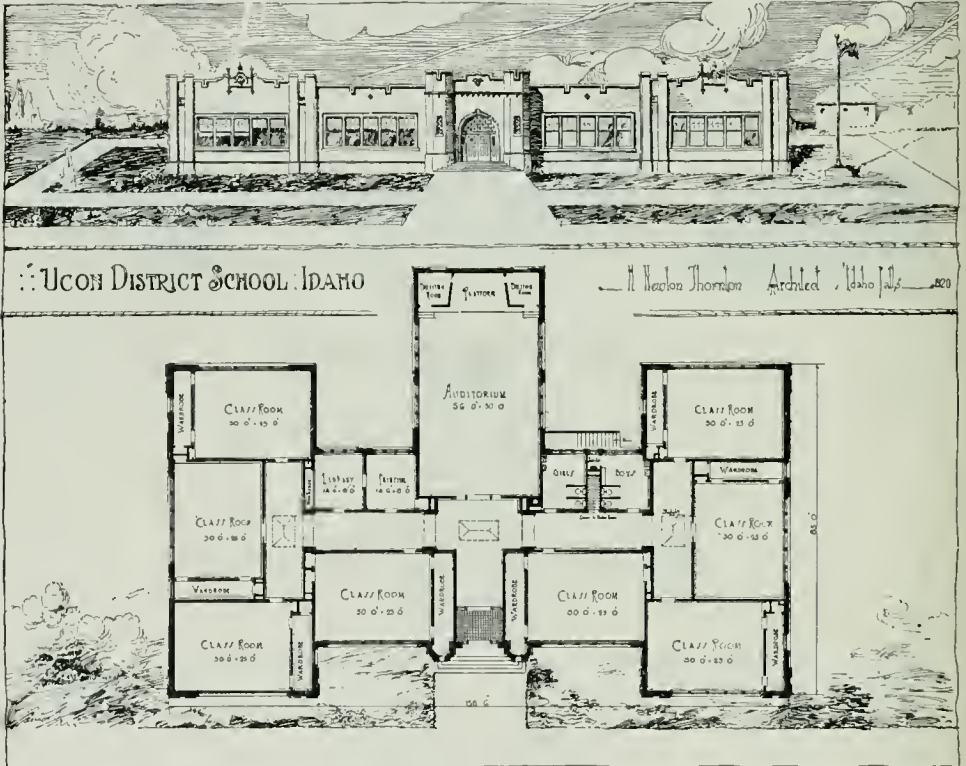

UCON DISTRICT SCHOOL, IDAHO
Newton J. Thornton, Architect

economy in cost of management, housing and maintenance, and will broaden the scope of the educational staff. Likewise, it will prove attractive to able men and women engaged in teaching to strive for greater leadership and high social standing in the community. In the long run, it will be found less expensive and more advantageous to have one large plant rather than several small ones. In well-developed cities the high school, costing as much as a million and a half dollars and even more, will not in the very near future be uncommon. Valuable service will be rendered if all school plants are planned for unrestricted growth. This requires a thorough knowledge of the school and a vision of the future. The greatest waste is to build so that additions cannot be made and that plants must as a result be abandoned after thirty or forty years of use.

Bond issues extend to almost that time, and it is unfortunate if the plant has to be discarded shortly after payment of the last installment.

The problems surrounding the planning and architecture of the elementary and intermediate, or junior high school, are no less important than those of the inclusive high school, although not so complex or numerous. But it is in the serious thought and study of these two plants that rests the hope of the nation. Indifference to the planning, sanitation, heating, and ventilation for these fundamental education buildings has given way to the purpose of having them adequately designed to meet their needs. It is expected they will be charmingly

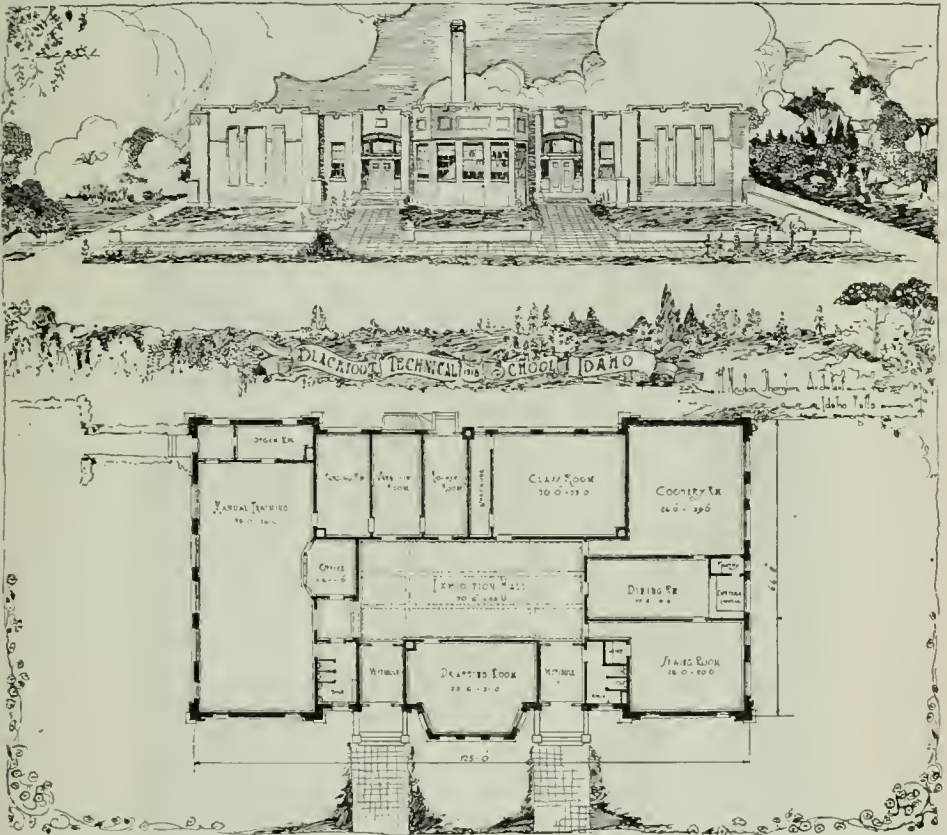

BLACKFOOT TECHNICAL SCHOOL, IDAHO
Newton J. Thornton, Architect

simple in their architecture and inviting in their appearance and surroundings. Just as their curricula are the foundations for higher education, so, too, is their architecture the foundation for greater development of American school architecture. Of late, in certain sections of the country, there has been a tendency to develop a compact, fixed plan which has been influenced by desires for economy. Desirable orientation and natural ventilation of rooms and corridors have necessarily been sacrificed in many instances in favor of compactness. Children of the age attending these schools require the most favorable hygienic conditions in order that their physical assets may be conserved to the fullest degree.

The writer is of the opinion that the open type of plan of the one-, two-, or three-story buildings is most conducive to good health, and that economies of space obtained in the compact scheme may be offset in the cost of construction of the open type. Certainly more sunshine is possible with the latter type of plan. But rather than prejudice the minds of those responsible for the erection of schools, it should be clearly understood that each problem is distinct and separate in itself; and its plan and construction should be based on the conditions governing its study.



GRAMMAR SCHOOL, COLUSA, CAL.
Wm. H. Weeks, Architect

THE EXTERIOR COMPOSITION

However good the plan of a school may be, or whatever the excellence of its capability for administration and instruction, unless it is accompanied by a pleasing composition of the exterior, it will soon lose its prestige and be forgotten. One of the important functions of school architecture is to sell education to the public. This is accomplished by making attractive that side of education which the public see most. So much has been written and said about the educational value of good architecture to the community, that it is needless to repeat here what has been so thoroughly propagated to influence civic interest for good public buildings. But appropriately something may be mentioned about the educational value to children and students of housing them in

buildings having merit in form, proportion, and good taste both without and within.

Much effort is made within the school to teach children to draw accurately and freely, to paint with oils and water-colors, to comprehend proportion of areas and figures, to understand the history of art and civilization, and to master other subjects which lead to the realms of art. The motive prompting this work is not that a livelihood will be made from such brief training, but that the child will be trained to have a sense of appreciation for the beautiful which he may



GRAMMAR SCHOOL, COLUSA, CAL.
Wm. H. Weeks, Architect

express in other forms of life's activities. Therefore, is not this appreciation greatly enhanced and fostered if the building and its appointments are executed so that the mind, at its impressionistic age, may have good examples constantly before it? Set a child to draw a picture of a house, and immediately he will attempt to reproduce his impression of his own home, showing that he has been influenced entirely by his environment.

Prisons and jails are built to express severity and confinement. To see nothing else but their heavy, crude walls and buildings is a punishment almost equal to the restrictions of freedom within them; and the mental depression caused by the severity of their architecture has its own discouraging influence. A similar influence has been felt by the child whom circumstances has forced to work in mills and factories at an early age and by children having to attend

schools whose architecture paralleled that of the jail or the factory. How often has the boy of sound mind wished dire happenings to the school, which meant nothing more to him than a place of confinement and restriction! Much of this ill-will is traceable to the forbidding impression of the school building, with its uninviting exterior and its dark and poorly ventilated corridors and rooms. Happily the renaissance in school architecture which has taken place during the last ten years has modified this feeling of the child towards the school. The provision of better facilities for play has had much to do in changing the child's attitude; but the charm of simple pleasing architectural forms, together with grounds graced with appropriate foliage and lawns, has had its influential effect upon the adult as well as upon the pupil.

The efforts of those interested in child welfare and in the future of the nation are directed towards extending and prolonging the period of early education. If this movement is to be successful and profitable to the State, it must meet with the fullest co-operation on the part of the child, whose voluntary attendance is worth more than his coming through fear of the law. And to enlist this co-operation, it is fundamental that the school in its appearance shall be attractive to the child.

This can be brought about in no better way than by erecting simple, pleasing architectural buildings at the very beginning for the elementary schools. Here the small child receives his first impression of the school and the world, an impression not subject to early change, as he is likely to attend the same school for a number of years. Consequently, the child should be the motive for the architecture of this grade of school buildings, and not some time-honored example of a great period of development in architecture. The composition should reflect the spirit, quietness, and refinement of a good home. A transition takes place in his life as soon as the child first attends school, and that transition should be accompanied with delightful discoveries of new forms and environments pleasing to the senses. Until recently there has been too much effort to show how much architecture could be put into even the simplest of problems. Meaningless domes, bombastic use of the orders, wonderful creations of the monumental misapplied to the unpretentious, have had their day in the development of American school architecture, and it is to be hoped they are never to return.

The word "classical," with all its magic, will not influence the intelligent layman to connect modern school design with that meaningless phrase as applied to architecture. It is effeminate to talk of styles of architecture, and slavish to force their forms into a well-organized plan. Each problem should have an architecture or composition of its own in keeping with the plan, the locality, the materials accessible, and the many other factors influential in its study. If the school is first viewed as a technical problem and solved in plan from this standpoint, then, with the use of good materials and simplicity as the main motive, there will be no question about the successful progress of school architecture. What has been said about the architecture of the elementary school is equally applicable to the architecture of the high school. Here, however, the child has advanced to and beyond the adolescent age when its mind is most confident and critical. And as the impressions of the elementary school should be influential to attract the child to school life, so too should the high school exact influence to impress upon the student the value of dignity, proportion, and good taste. As the child should be the motive for the architecture of the earlier school, likewise the student should be the motive for the architecture of the advanced school. The high school is the last seat of learning to be attended by the greater number of students enrolled within it, and, if for no other reason, it should present them with visions of accomplishments in life. Pride in country and in citizenship is dependent on the creative power of the people as well as



HIGH SCHOOL, HEALDSBURG, CAL.
WM. H. WEEKS, ARCHITECT

upon the laws guaranteeing liberty and social possibilities. The high school student is quick to perceive the merits of this creative ability. Therefore, if our schools are to fulfill their functions, their outward appearance should have the character, repose, and presentation befitting the important work going forward within.

STANDARDIZATION

In the chapter on elementary schools, it has been pointed out that standardization is likely to lead to stagnation. This is quite true unless standardization is applied only to the details of construction, which may be standardized without restricting the general development of the administration and instruction within the school. Educational methods are rapidly changing, and will change just as long as progress is made. When they cease to change, stagnation and then decadence follow. Consequently, the building should be constructed to permit the greatest flexibility in arrangement of rooms, even after the building is completed, so that the construction will always be adaptable for modification to the school organization. In a recent report to the New York City Board of Education, on Public School No. 29, Mr. C. B. J. Snyder, architect, pointed out many means and ways towards standardization of the architectural details within the building, for instance that the ventilating ducts enter the classrooms from the ceilings of the corridors, so that dividing partitions may be changed at will. He also prepared the specifications so that different systems of construction and materials, equally good, may be optional with the contractors.

Such standardization is commendable, but whenever standardization takes the form of limiting freedom in design and composition, or the endeavor to make the community fit the school instead of vice versa, then standardization is nothing short of a prolonged menace. If the aesthetic and educational value of a well-designed exterior is to be disregarded and schools are to be erected like so many factory buildings, then standardization some day is bound to reflect on its followers. Or if plans are to be standardized, and fixed forms erected repeatedly, then progress in school planning will cease. However, duplication of types at a particular period, and for the same grades of schools operating, under similar conditions in the same community, is not at all unfavorable to the progress of school architecture. Such standardization should be handled skillfully and only after the original types have been carefully studied, for there is likely to be duplication of errors as well as of good features. Just how a community would appreciate ten or fifteen schools of the same general plan, and with practically the same exterior appearance, is problematical to the writer. A final word may not be amiss on the subject of standardization relative to its adoption when applied to buildings as a whole; the orientation, the topography, the size of the different sites, the enrollments, and the social character of the neighborhoods, are matters which should determine the feasibility and the wisdom of duplication of types of school buildings.

LEGISLATION

The time has arrived when there should be some uniformity in the school building codes of all the states of the Union. That this may be accomplished, a Federal commission should be created which would carefully study, first the problems of safety and health, and then the details of efficiency and economy in the erection of school buildings. Reports by this commission could be adopted or modified to suit local conditions, by similar commissions or bureaus created by each State. If such bureaus were permanent, with the proper authority to enforce the laws governing safety requirements and health regulations, and if they were equipped with a trained personnel co-operating with the educators of the State and Nation, a great and sound progress in school building would ensue. Just prior to the United States entering the war, the Nation was spending

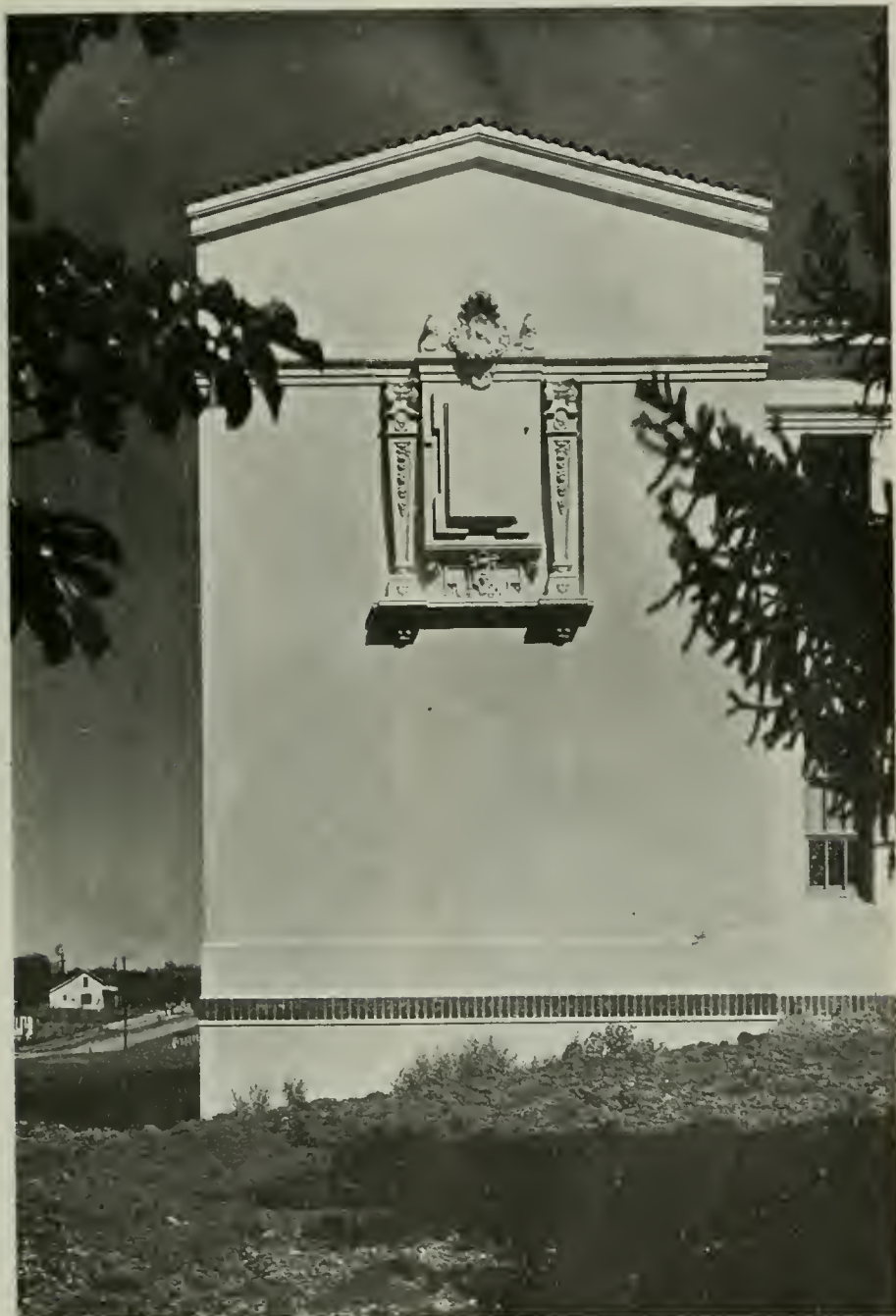

HIGH SCHOOL, HEALDSBURG, CAL.
WM. H. WEEKS, ARCHITECT

more than one hundred and twenty-five millions of dollars annually for the building of public schools. Of this vast sum a very large percentage was spent for buildings erected in states having few, if any, regulations covering the subject; and some of it was spent in states having codes which are rightfully considered drastically precautionary. On the one hand, haphazard planning has followed, while on the other an unnecessarily wasteful expenditure of resources has been the result, without any particular advantage being gained.

Empowered to pass on all plans and specifications, and free to make recommendations, bureaus of the character suggested would do much towards conserving health and wealth and preventing the erection of poor buildings which could never be erected under proper regulation. It is far more wasteful to plan and build wrongly than it is to plan correctly with too large a factor of safety, although there is no excuse why both extremes should not be obviated. The trend of the times is to expand along broad constructive lines to conserve in all fields of resource in order that the expansion may be all the more effective.

Possibilities for expansion in education are infinite, and the entire Nation is eager to co-operate and take part, but unless it is intelligently and wisely directed and founded on the purpose to conserve human and material resources, unfavorable reactions will unquestionably follow.

CONSTRUCTION

Under this heading it is not advisable to attempt more than a few general statements regarding the use of good materials, the necessity for proper inspection of the construction, the selection of the architect and his responsibility. In the chapter on the "Cost of School Buildings" the different grades of construction are classified, as it was found necessary to define clearly these classifications, since the cost of buildings is closely related to the different types of construction.

MATERIALS

The distinction between economy and cheapness, as applied to buildings, warrants a clear definition. Economy in building means the avoidance of waste in the design of the construction; the selection of materials which will withstand the ravages of time and appropriately express the architectural design worthy of the citizenship it represents; and the employment of the highest grade of workmanship, fabricating the materials so that after the building is completed, the minimum of maintenance charges will follow. On the other hand, cheapness in building implies the use of materials and workmanship of little value, and means that, for the time being, the building will have only the appearance of substantiality. Cheapness also means low cost of construction and high cost of maintenance. Cheaply constructed buildings are perpetual liabilities, and after a short time, are worse than worthless because of the cost of maintenance.

The "catch-penny" phrase of building inexpensively means nothing more than the substitution of cheap, temporary materials for those of permanency and character. Unfortunately, attempts are made to beguile the layman into believing that long experience in the trade of handling cheap materials and erecting temporary commercial buildings has brought about an adeptness akin to cleverness in the use of cheap materials. But it is a known fact that workmen will not take the same interest in their work when using cheap materials as when applying good. The same is true of the public's appreciation of the school buildings erected by public funds. Nothing can be more harmful to the success of education than that people should feel general distrust and dissatisfaction in the character and quality of the construction of school plants. Furthermore, there is a nobility of character and a sense of security in the use of permanent materials which temporary or cheap materials cannot express.

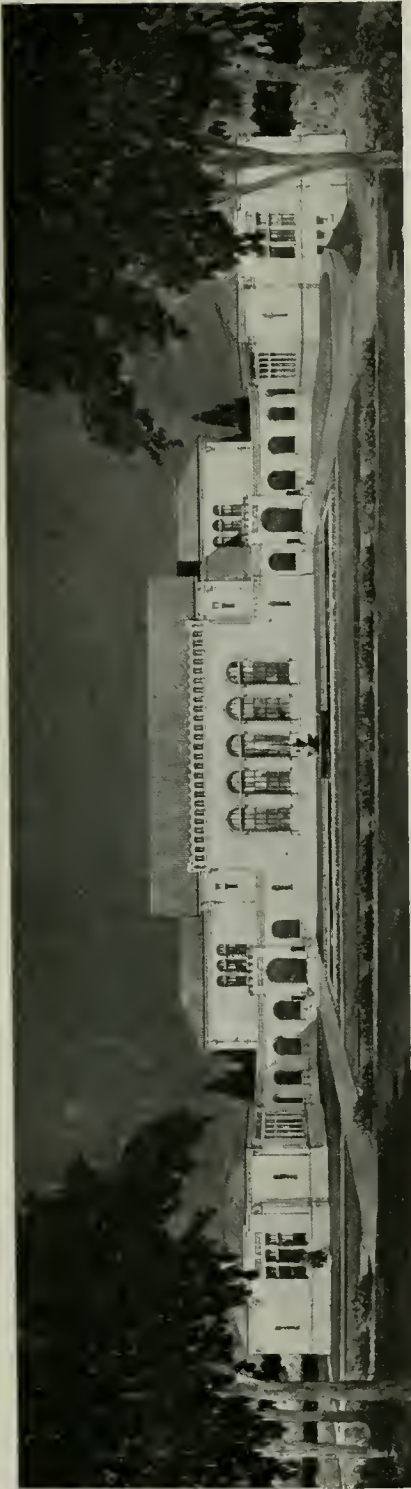

HIGH SCHOOL, PIEDMONT, CAL.
WM. H. WEEKS, ARCHITECT

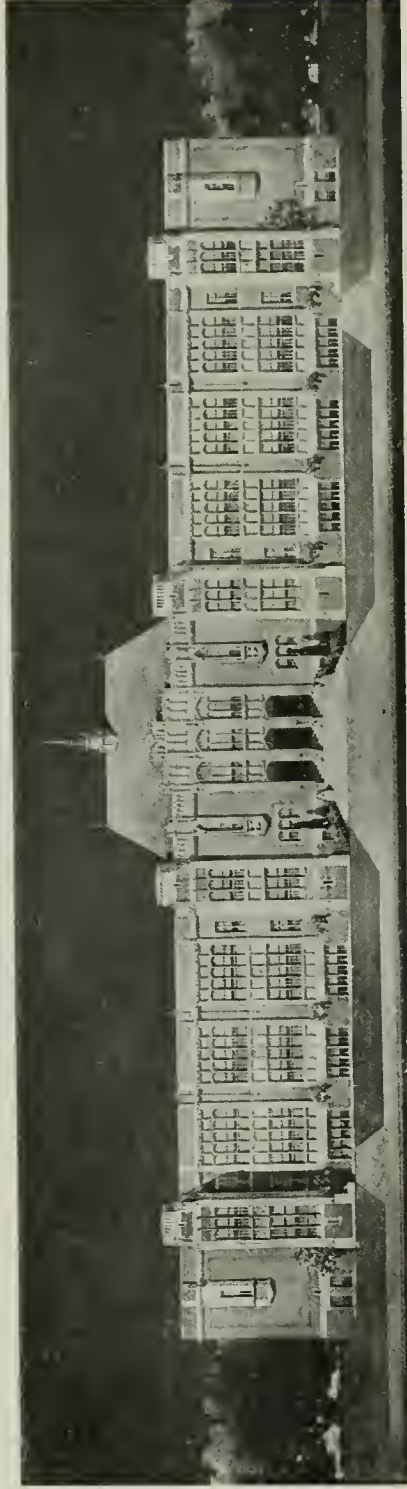

HIGH SCHOOL, POMONA, CAL.
ROBERT H. ORR AND WM. H.
WEEKS, ASSOC. ARCHITECTS

INSPECTION

Every school building costing more than \$20,000 should have a competent building inspector appointed either by the architect or the board of education, and his salary should be paid directly by the board. He should represent both the board of education and the architect, and it is generally better if he is recommended to the board for employment or dismissal by the architect, as the latter can then be responsible for the proper conduct of the work. The expense of such inspection is justified in every instance and is an obligation on the part of the board as a protection to the city or district. Very often to drive a good bargain with the architect, boards of education will attempt to impose this expense upon him. Invariably the result is the employment of an inexperienced man who is willing to serve for a compensation far below the value of the services to be rendered, and in consequence, the board, the architect, and the contractors are all involved in disputes and misunderstandings. There is no other expenditure connected with the construction of the building more impor-

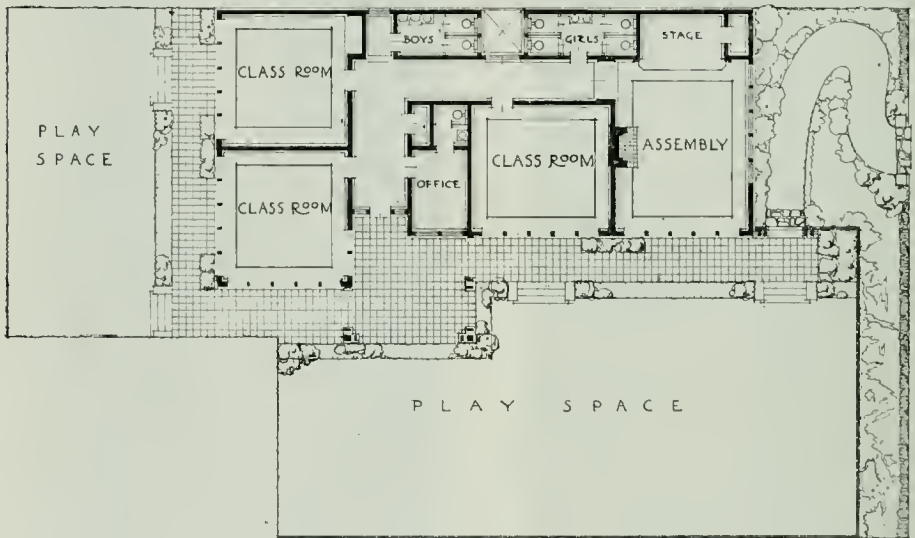

PRESIDIO OPEN AIR SCHOOL, SAN FRANCISCO
William C. Hays, Architect

tant than that allowed for the proper and constant supervision of the work as it progresses. A competent man will not only see that the work is executed according to the plans and specifications, thereby guaranteeing full value of materials and workmanship, but he will anticipate errors and wastes and often save the board many times the amount of his salary.

The reliable American contractor is about as fine a citizen as any with whom the Nation can be blessed. The opposite is true of the unreliable, and inasmuch as public work is generally subject to the freest competition, the successful bidders are unfortunately not always the most reliable. An unscrupulous contractor can easily cause a loss of more than several times the cost of competent inspection. After more than twenty-two years of experience in building operations, the writer is convinced that it would be far better to have the funds plundered directly to any extent, than to have the building cheated to the same amount in the quality or quantity of the materials. In the former case there is every opportunity for just retribution to reach the embezzler, but in the latter the safety of the occupants is involved. In both instances, the community is the loser. This may be avoided by safeguarding the conditions leading up to the

wrongdoing. Briefly, a few points to observe in building inspection are as follows:

Excavation—See that the proper levels and grades are maintained. All top soil should be placed convenient for rehandling. Trees for future use should be protected.

Concrete Work—Each batch of concrete should be accurately measured and properly placed, tamped, and protected. All reinforcement should be bent correctly and rightly placed. If the structure is economically designed, the sizes and locations of the steel rods and mesh should be carefully inspected in every column, girder, beam, slab, and wall. The safety of the occupants is dependent upon the inspection as well as the design. All finished concrete and cement

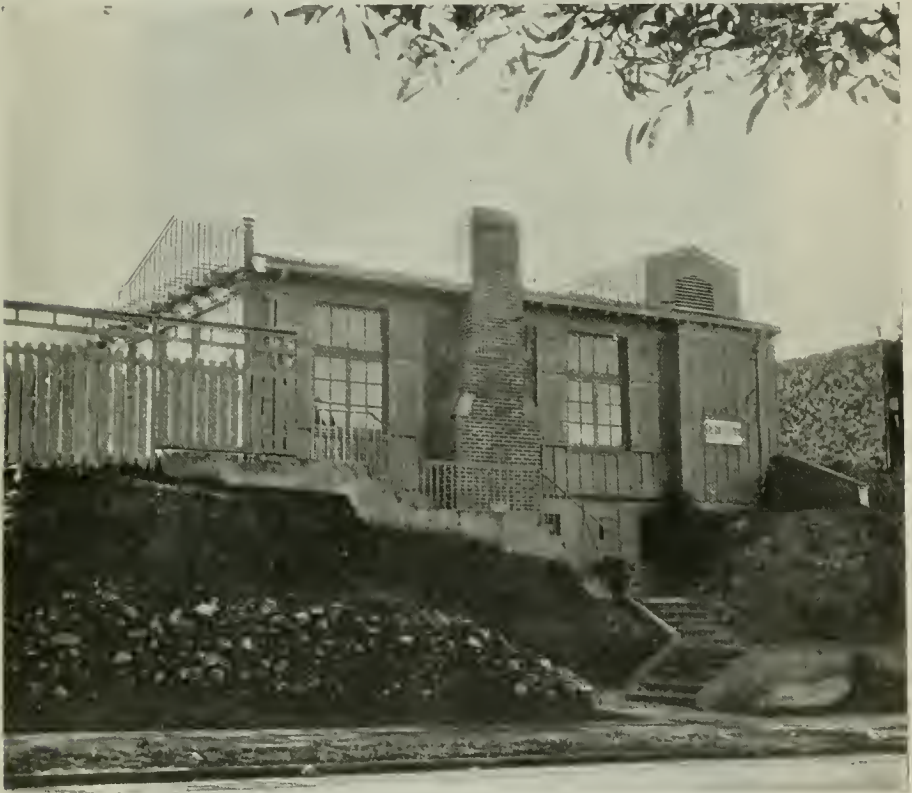

PRESIDIO OPEN AIR SCHOOL, SAN FRANCISCO
William C. Hays, Architect

work should be kept in a moistened condition for a period of two weeks, except during freezing weather.

Steel—All work should be plumbed after erection, and all connections riveted tightly. Loose rivets should be rejected, and bolted work should be avoided as far as possible. Unless the steel is inclosed in concrete it should receive two good coats of paint: (a) a shop coat, and (b) a field coat, of contrasting color applied after all riveting and other steel work is completed.

Masonry—All brick joints should be solidly filled with mortar properly gauged and the bricks should be in a partly saturated condition when laid.

Carpentry—Inspection of this branch requires a wide experience. Selection of the lumber is important. Following up the nailing, placing of the grounds for the finish, judging the quality and character of the finish, inspection of the

workmanship of the latter, the laying of the floors, and the checking of multitudinous details is a responsibility that can be executed only by a thoroughly competent man.

Plastering—First of all, the lathing should be closely inspected. Then the mixture and application of the mortar is very important if the finished building is to be creditable to all concerned in the project. All exposed corners should have galvanized metal corner beads, and all angles and wall surfaces should be plumb and true. The thickness and finish of the mortar and number of coats should be clearly specified and carefully checked.

Painting—The material should be checked as it arrives on the job, and adul-



PRESIDIO OPEN AIR SCHOOL, SAN FRANCISCO
William C. Hays, Architect

teration should never be permitted. Large quantities of gasoline or naphtha on the premises are a sure sign of danger ahead. Each coat should be identified by some mark, and all rubbing of surfaces should be constantly followed.

Hardware—Only standard makes should be specified, as special hardware and renewals are unnecessarily expensive. However, it should be a good quality, as it is subject to much usage. Brass or bronze should be the metals used for all exposed exterior work. Very often sherardized steel, brass plated, makes a good substitute for interior hardware finish. If brass or bronze is specified, a steel magnet is a good aid to inspection of the make of the material.

Glass—The thickness and quality of the glass are the principal points to follow in this branch. Only the better grades should be used below a height of

eight feet. Above that, it is permissible to allow the use of the less perfect material.

Blackboards are fully covered in the chapter on "Classrooms," and heating, ventilation, plumbing and electrical work are also treated in separate chapters, because of the importance of the engineering required for these branches of the special work.

The above notations are only a few of the many factors involved in the erection of a school building, and are submitted for the benefit of the school superintendent, who may be called upon at times to assume the responsibility of acting as the board's representative on the work.



PRESIDIO OPEN AIR SCHOOL, SAN FRANCISCO
William C. Hays, Architect

THE ARCHITECT AND HIS SERVICE

Selecting the architect is very often made a difficult task, although it should be a very simple matter. To be sure, the authority of choosing is accompanied with its sense of responsibility, but if any member of a board of education had a legal case at hand, he would not hesitate very long in choosing an attorney skilled in conducting cases similar to his own. Furthermore, if a member of his family required the attention of a physician it would not require much deliberation to select a man in whom he had the utmost confidence. Boards of education are applying these same principles in selecting their architects.

The architect of experience and standing in this field of the profession is aware of the futility of entering competitions, and unless the office is equipped for such competitive work, and makes a practice of entering competitions of every nature, it is found to be an expensive gamble. An occasional competition, however, is often a good tonic for any office, as it discloses the cobwebs and raises the standards of what might be termed academic design. However, every competition requires a carefully prepared program, resulting from the study of the problem by an architect acting as adviser—one who understands the school and its functions, and can clearly state the requirements and give the proper correlation of rooms and departments. Then it is absolutely necessary that the judges be men of recognized, unquestionable standing in the profession, and chosen for this purpose by ballot cast by the competitors. Furthermore, no competition requiring the submission of drawings should be held until its program and conduct has received the approval of the local chapter of the

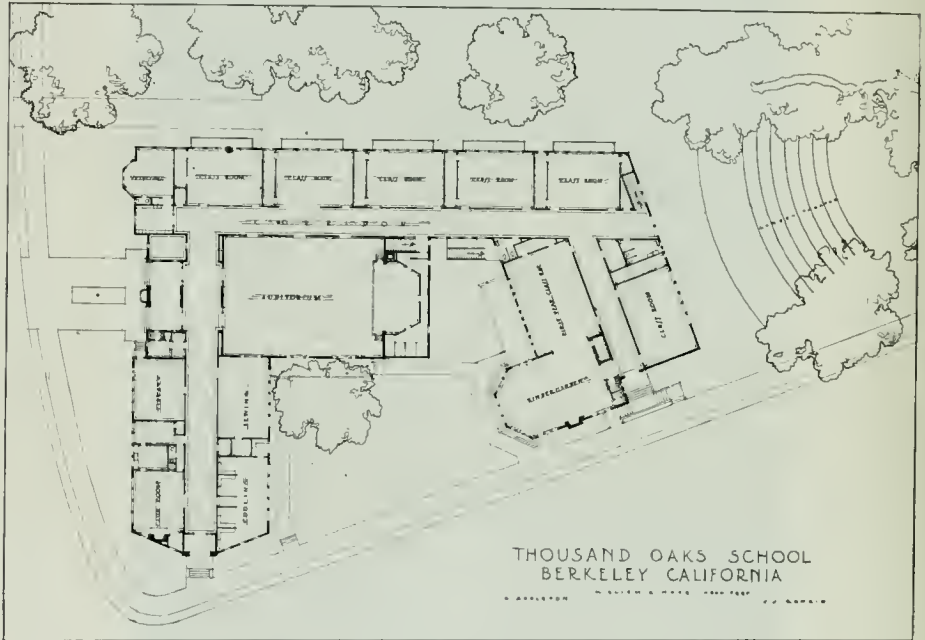

THOUSAND OAKS SCHOOL, BERKELEY, CAL.
William C. Hays, Architect

American Institute of Architects. The writer is fully aware that this is often contrary to the wishes of the average board of education favorable to competitions. Nevertheless, and with every regard for the integrity and honesty of the members of such boards, it is impossible to conduct an honest and fair competition otherwise. Moreover, architects capable of rendering the required service will not enter competitions conducted on any other lines, as experience has demonstrated that they result in nothing but dissatisfaction and unsatisfactory service. Boards of education, too, have found that competitions are unprofitable, and realize that the problem requires special study, which can be more satisfactorily followed if they and their representatives co-operate with the architect from the very beginning of the undertaking.

The practice of architecture is a business as well as a profession. It requires a thorough knowledge of the different building crafts, and a capability to execute the financial expenditures of the client to such a degree of precision that wastes and losses are avoided. It first involves a training in the theory of

architectural design and engineering, and then an extended experience in the practice of building management and the application of sound business principles. From this, it is evident that in the selection of an architect the board should choose the man whose work pleases or satisfies them and in whom they can repose confidence.

The building costs one hundred per cent of the contract price. The architect's fee is six per cent of that cost, which is less than one-sixteenth of the total cost of the building. If proper value is rendered in service, it is not possible to measure it either by figures or terms. For the value continues indefinitely. Conversely, improper service bears with it a just retribution in the loss of confidence and repute, unescapable and as unending as the life of the man or the building. There should be no division of the architect's responsibilities. Not only should he be responsible for the execution of the drawings and specifications of which he is the author, but in order to protect the interests of his client to the fullest extent of his capability, he should have undivided authority as to the conduct of the work. Division of responsibility follows division of authority, which opens the way for irregularities and inferior values in the



THOUSAND OAKS SCHOOL, BERKELEY, CAL.
William C. Hays, Architect

performance of work. In return for the board's confidence, the architect should take every measure to solve the problem in the interest of the client and for the successful advancement of education. This means rendering the best available engineering service as well as competent architectural service.

The trend of the times indicates a mutually happy, confidential relation between the educational and architectural professions, and between the latter and boards of education who represent the public at large. Occasionally, paltry politics or misguided personal friendships will counteract progression in the development of the problem and halt solution of the many intricacies which go to make up the whole. It requires years of practice and association for the architect to anticipate the pedagogical requirements and correlate them with the physical or architectural possibilities so that the building squares with the organization of the school and vice versa. It also takes time for superficially brilliant tyroes to learn that the school is not a plaything upon which to perpetrate architectural stunts in the solution of its plan or in the composition of the facades. To the credit of the architectural profession, such cases are rare. The best evidence of this is shown in the splendid character of most of the modern American school architecture.



SKETCH SHOWING COMPLETION OF THE THOUSAND OAKS SCHOOL

(See previous page)

THOUSAND OAKS SCHOOL, BERKELEY, CAL.
WILLIAM C. HAYS, ARCHITECT

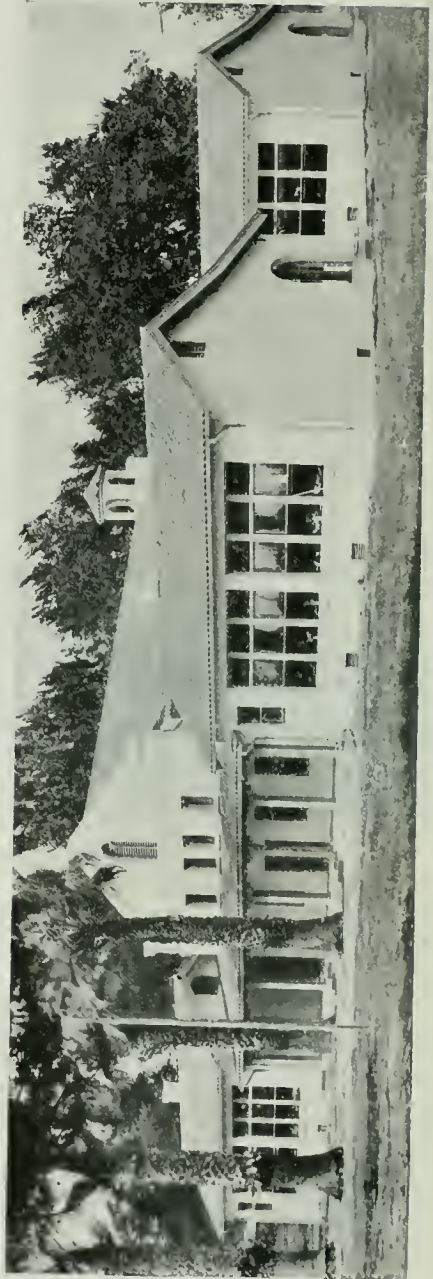

GRANGEVILLE DISTRICT SCHOOL AND SOCIAL CENTER,
GRANGEVILLE, CAL. ERNEST J. KUMP, ARCHITECT

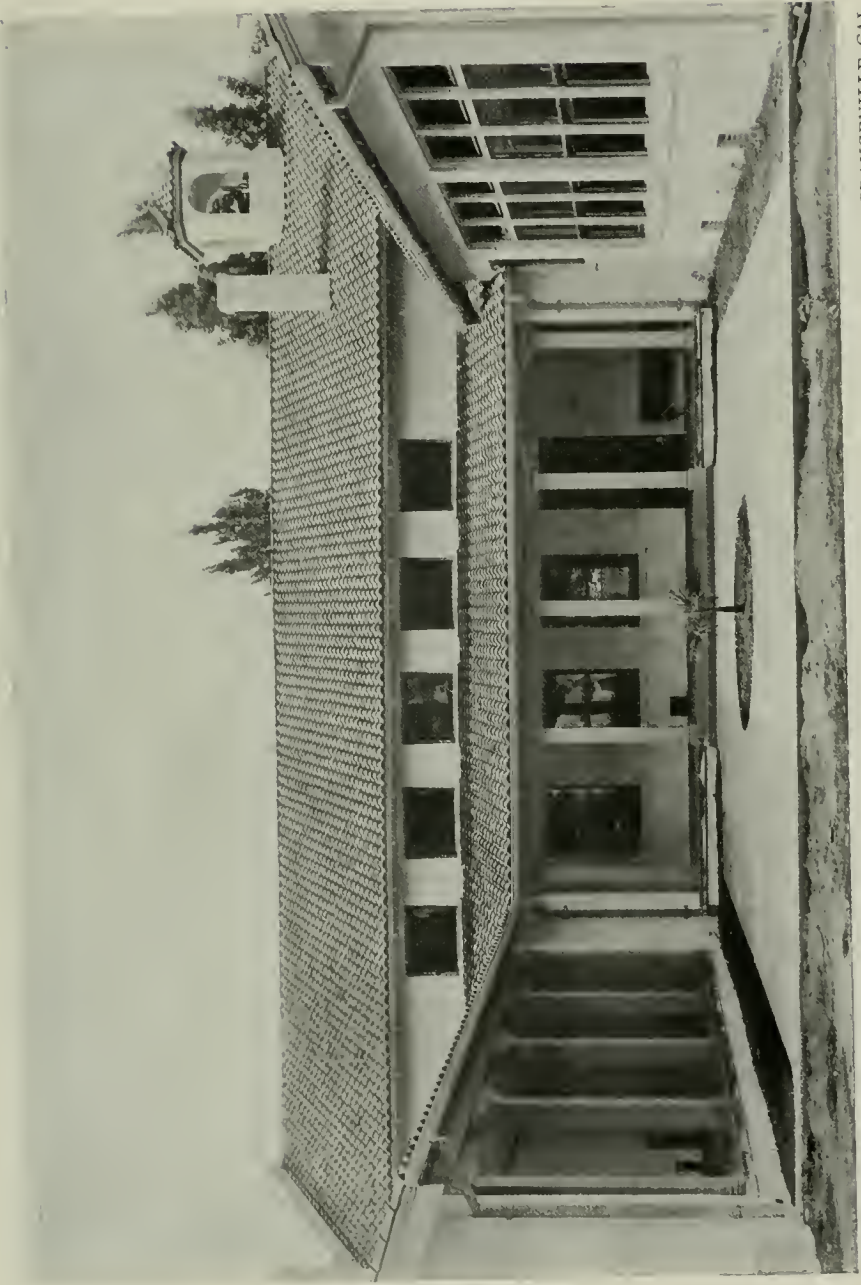

GRANGEVILLE DISTRICT SCHOOL, GRANGEVILLE, CAL.
ERNEST J. KUMP,
ARCHITECT

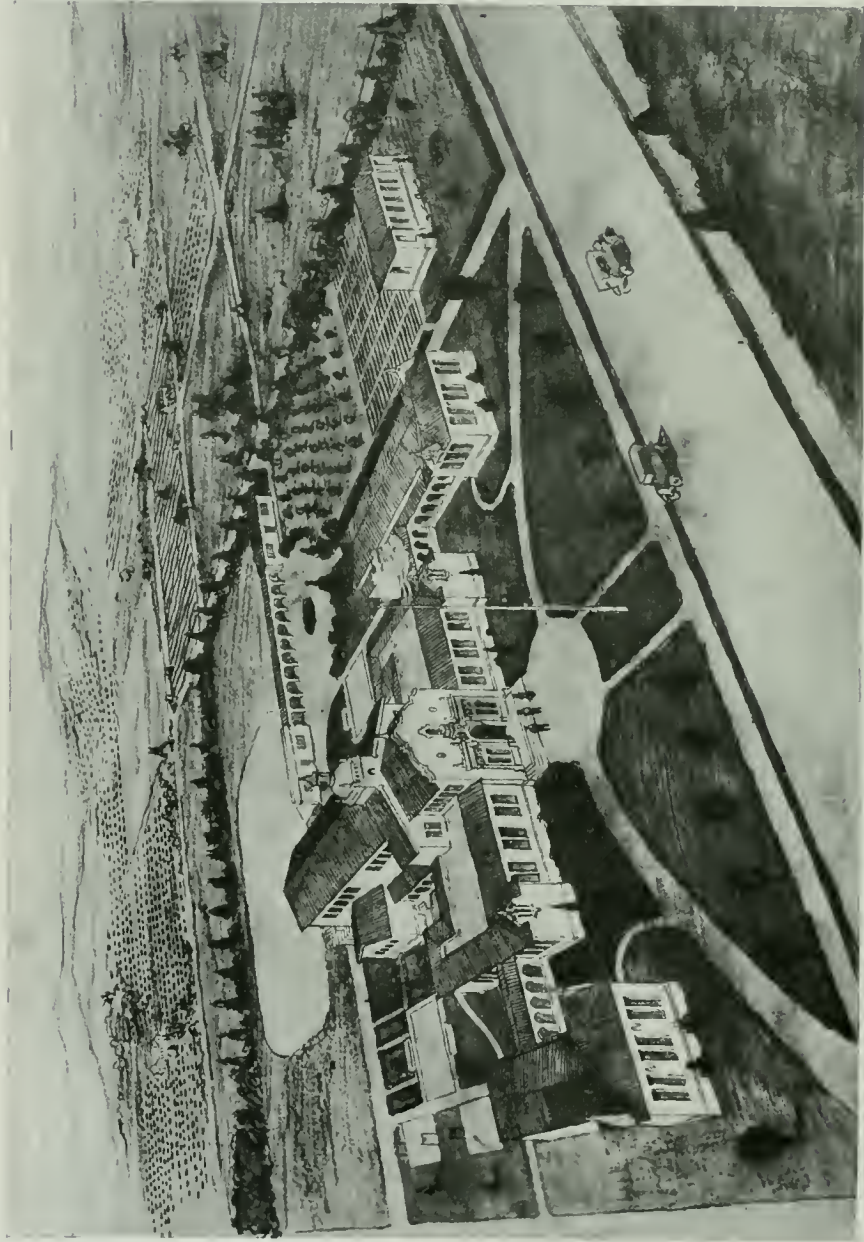

ONE-STORY UNIT GROUP HIGH SCHOOL
ERNEST J. KUMP,
ARCHITECT

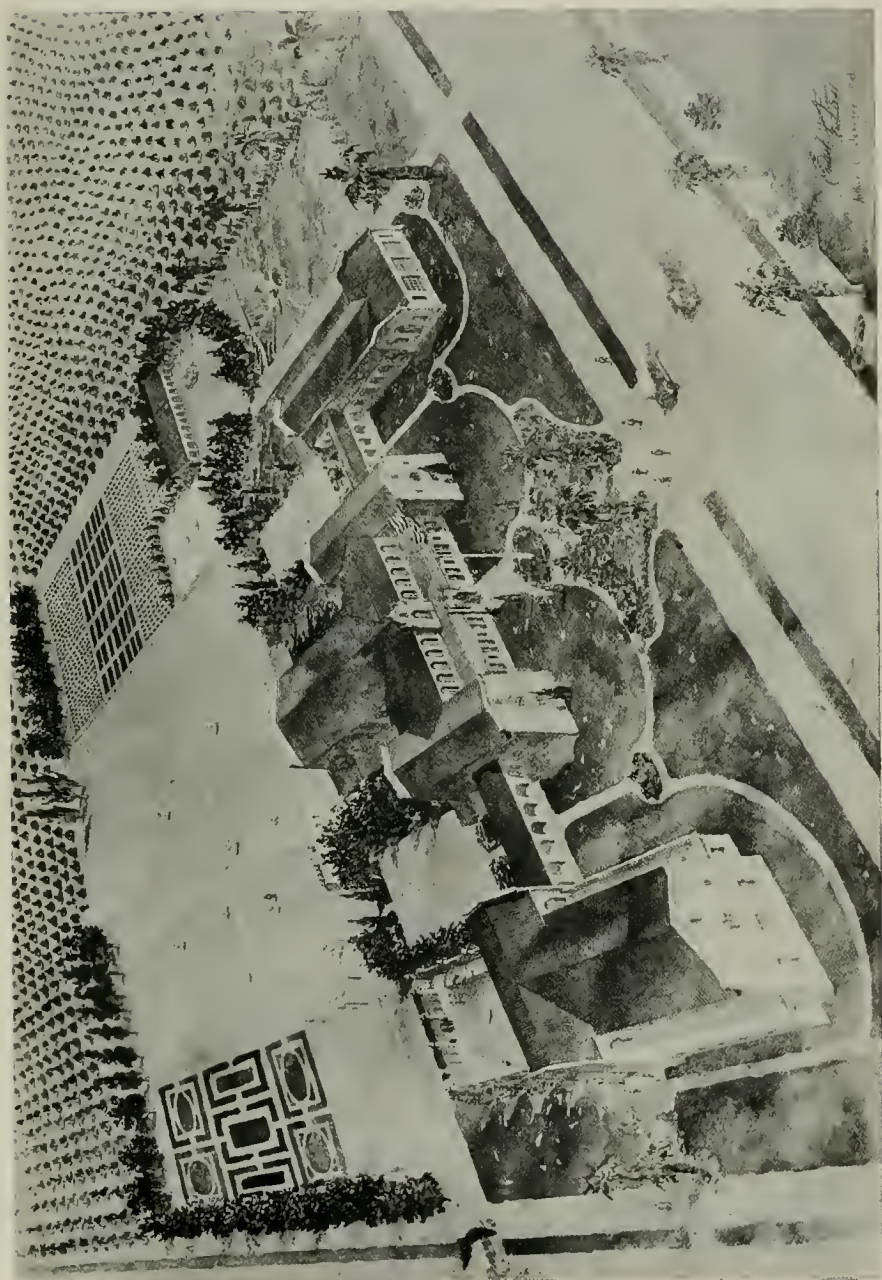

LINDSAY HIGH SCHOOL, LINDSAY, CAL.
ERNEST J. KUMP,
ARCHITECT

Ernest J. Kump
Architect



STRATHMORE UNION HIGH SCHOOL, STRATHMORE, CAL.
ERNEST J. KUMP, ARCHITECT

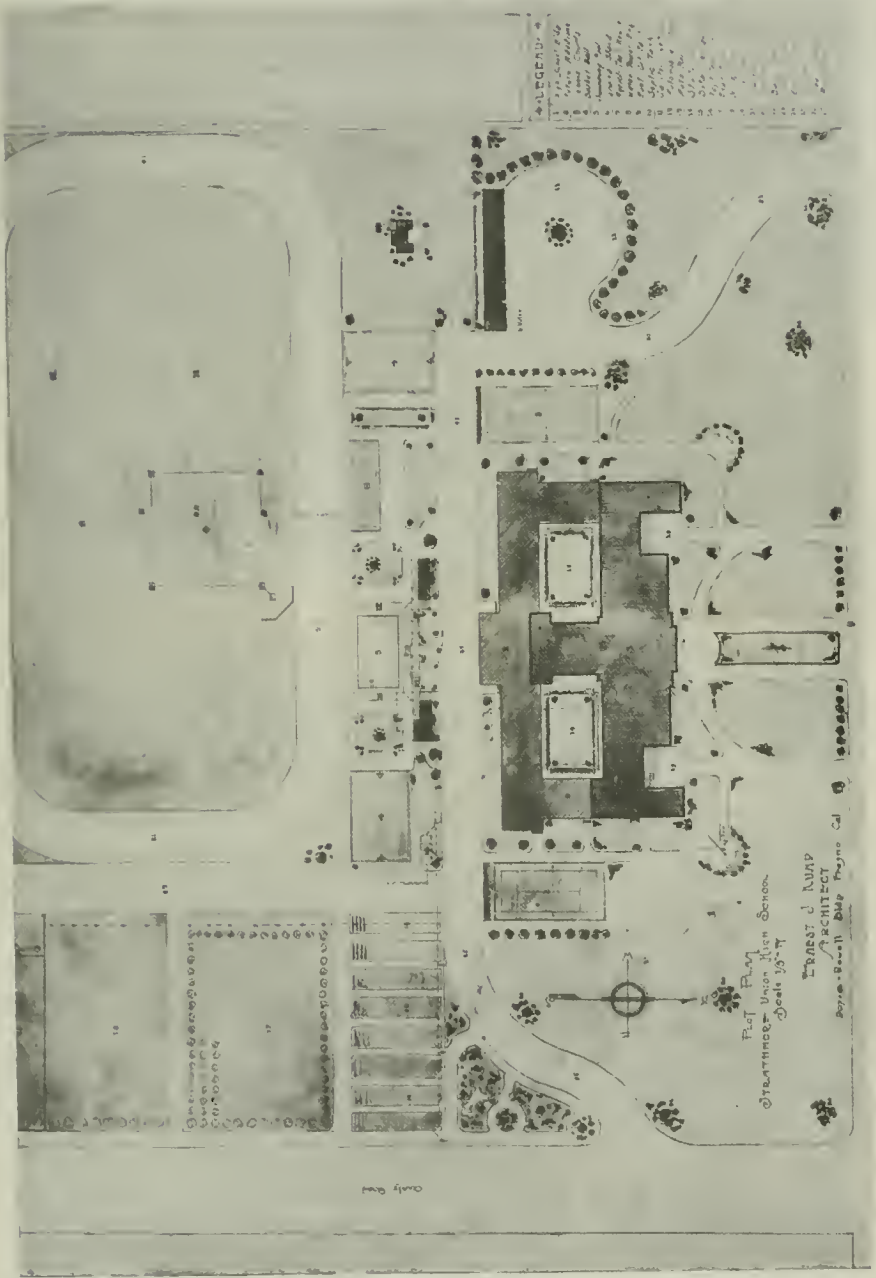

STRATHMORE UNION HIGH SCHOOL, STRATHMORE, CAL.
 ERNEST J. KUMP,
 ARCHITECT

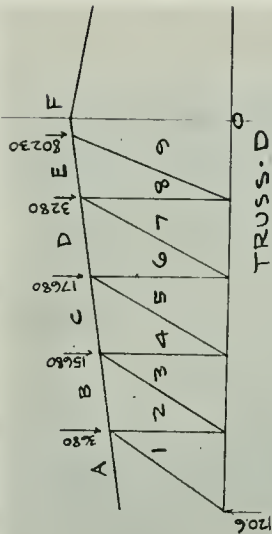

TABLE-IV

MEMBER	STRESS	CARRYING CAPACITY	PERCENT OVER-STRESS
E-B	+21700.0	+10450.0	108%
D-G	+18150.0	+10450.0	80%
B-2	+8100.0	+4450.0	82%
C-4	+14400.0	+4450.0	223%
A-1	+14500.0	+8600.0	68%
2-3	+12300.0	+8640.0	42%
4-5	+9000.0	+6500.0	39%
6-7	+6400.0	+3520.0	82%
8-9	+5300.0	+2900.0	56%
1-2	-10500.0	-7460.0	32%
3-4	-8000.0	-6750.0	18%
5-6	-5700.0	-4700.0	21%
7-8	-4900.0	-3700.0	33%
0-1	-8000.0	-11000.0	0%
0-3	-14300.0	-11000.0	30%
0-5	-1800.0	-17500.0	6%
0-7	-21500.0	-17500.0	23%
0-9	-23300.0	-17500.0	33%

$P = 16000 - 70 \frac{1}{2}$

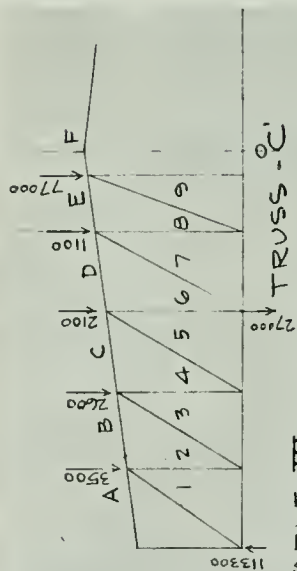

TABLE-III

MEMBER	STRESS	CARRYING CAPACITY	PERCENT OVER-STRESS
E-B	+21300.0	+9840.0	116%
D-G	+18700.0	+9840.0	90%
B-2	+7600.0	+3600.0	111%
C-4	+13900.0	+3600.0	285%
A-1	+13800.0	+8600.0	62%
2-3	+11800.0	+8640.0	37%
4-5	+10000.0	+6480.0	54%
6-7	+5700.0	+3520.0	62%
8-9	+4400.0	+3380.0	45%
1-2	-10000.0	-7950.0	26%
3-4	-8700.0	-6750.0	29%
5-6	-7800.0	-4700.0	66%
7-8	-4600.0	-3710.0	37%
0-1	-7500.0	-11000.0	0%
0-3	-13700.0	-11000.0	25%
0-5	-18500.0	-17500.0	6%
0-7	-21000.0	-17500.0	20%
0-9	-22700.0	-17500.0	30%

$P = 16000 - 70 \frac{1}{2}$

EULERS FORMULA
 $P = \frac{\pi^2 EI}{L^2}$

TABLES SHOWING STRESS CALCULATIONS, ETC., OF TRUSSES C AND D, LONG BEACH CHURCH



VIEW OF WRECK LOOKING NORTH, LONG BEACH CHURCH
(Photo taken December 17, 1920)

Church Dome and Supporting Trusses Collapse*

By J. J. ROSEDALE, Construction Engineer.

Department of Safety, Industrial Accident Commission of the State of California

ON December 16, 1920, at about 12:05 p. m., when fifty workmen had gone to lunch, the dome and roof trusses of a church under construction in Southern California collapsed. It was fortunate that this structure failed at that hour as only seven workmen were temporarily injured. The building was almost completed and would have been ready for occupancy by February, 1921.

The concrete dome, approximately 50 feet in diameter, was supported by a framing of structural steel trusses, which in turn were supported by reinforced concrete columns at the four corners of a rectangle 62 feet nine inches by 61 feet 6 inches.

DESIGN OF TRUSSES AND DOME

The stresses were calculated for the actual dead load plus a live load of 30 pounds per square foot on all flat roofs, and 15 pounds per square foot of horizontal projection of all domes.

The top chords of the main trusses, consisting of two channels separated by the gusset plates, were found to be insufficiently braced laterally, resulting in high unit stresses in the toes of the channels of the chords.

The dome is octagonal in plan, supported by sixteen reinforced concrete arched ribs, extending radially from the central lantern, making approximately equal angles. These ribs extend vertically below the spring line of the curved portion of the dome, resting on the structural steel beams and trusses. The slab is 3 inches thick, reinforced with a light wire mesh, and is cast monolithic with the ribs. The ribs are 12-inch by 12-inch in cross-section, and reinforced with two $\frac{5}{8}$ -inch square bars on top and bottom.

The internal stresses in the ribs were calculated by assuming that the ribs are hingeless arches, fixed against rotation at the spring line. The critical stresses were found at the spring line. At this point a bending moment was found, due to the horizontal thrust at the support. This produces a stress in the extreme fibers on the compression side of the ribs, of 2,930 pounds per square

*This article will be published in the April California Safety News.



PROGRESS VIEW OF CHURCH AT LONG BEACH, CALIFORNIA, BEFORE COLLAPSE OF STEEL TRUSSES



ARROW POINTS TO BREAK IN BOTTOM CHORD OF TRUSS D, REFERRED TO IN TEXT

inch. This is greatly in excess of the probable ultimate crushing strength of the concrete. The wire fabric in the dome slab was placed radially instead of spanning between the ribs.

The reinforced concrete columns supporting the steel trusses were found amply strong enough to carry the superimposed axial loads, but the detail of the connections of the trusses to the tops of the columns was not very secure.

FIELD INSPECTION OF TRUSSES

The riveting work of the trusses showed a lack of inspection. Numerous rivet heads were improperly formed. In one case, a connection angle had come off, slipping over the poorly formed head of the rivet.

The upper chord members were originally shown on the plans, riveted with stitch rivets between panel points. Upon examination of these trusses it was found that the stitch rivets were omitted. Many parts of the trusses were punctured with unused rivet holes for no apparent reason.

Six specimens of the structural steel were tested and found to be of good quality.

CONCRETE AND REINFORCING STEEL IN DOME

The concrete work appeared to be of good quality. The columns supporting the dome remained in place and in general only such portions of the concrete structure as received heavy impact failed.

CAUSE OF COLLAPSE

It is probable that the primary cause of the failure was due to the buckling of one of the upper chords of either truss C or D.

The general position of the wreck indicated that either truss C or truss D failed first. Inasmuch as there was no fracture in the lower chord of truss C, it is probable that truss D was the first to collapse. Truss D contained a fracture in the lower chord, beginning at the lower flange of the chord channels, and extending up to but not through the upper flange of the lower chord. This condition would be expected if the upper chord of the truss first failed by buckling, due to the lack of lateral supports.

Although the concrete dome was seriously defective, on account of the absence of ring steel, there was no indication that any failure occurred in the dome until after the collapse of the steel. The dome was found considerably shattered, but had retained its original shape, indicating that it did not fail first. If the dome had failed first, it is probable that the steel trusses would have remained in position.

The probable causes of the failure of truss D are as follows:

1. Insufficient lateral bracing in upper chord of the truss.
2. The vibration and side thrust resulting from operation of the derrick, located at the center of truss D, supported by wooden joists.
3. The omission of stitch rivets in the upper chord.
4. The insufficient sections in many parts of the trusses and the eccentric connections.
5. Inadequate inspection of field work of trusses.

The defects apparent in the design of this structure are of such a simple and well known nature that only one recommendation suggests itself, namely, that a competent engineer be engaged to act independently to supervise the design as well as the construction of such buildings.

Acknowledgement is made to L. H. Nishkian, Consulting Engineer, San Francisco, for his valuable assistance in checking the plans and investigating the collapse of the above structure, and to H. J. Brunner, Consulting Engineer, and C. H. Snyder, Civil Engineer, San Francisco, for their services in checking the plans.

THE Architect and Engineer

INCORPORATED

Founded 1905 by E. M. C. WHITNEY

W. J. L. KIERULFF - *President and Manager*
 FRED'K W. JONES - *Vice-Pres. and Editor*
 L. B. PENHORWOOD - *Secretary*
 T. C. KIERULFF - *Attorney*

ASSOCIATE EDITORS

IRVING F. MORROW - *Architectural Critic*
 CHAS. H. CHENEY - *City Planning and Book Reviews*
 WILBUR DAVID COOK - *Landscape Architecture*
 WM. B. GESTER - *Inspection and Tests*
 O. P. SHELLEV, C. E. } *Fireproof Construction*
 F. W. FITZPATRICK, }
 T. RONNEBERG, C. E., - *Structural Steel*
 W. H. LOWE - *Roofs and Roofing*
 FRED'K N. WOODS, JR., - *Rock and Gravel*
 W. H. GEORGE - *Cement*
 CHAS. FELIX BUTTE - *Electrical Construction*
 H. J. BRUNNIER - *Reinforced Concrete*
 I. W. FRICKE, - *School Equipment*
 C. H. WHITE - *Hardwood*
 WILL J. FRENCH, - *Department of Safety*

Published Monthly in the Interest of the
 Architects, Structural Engineers, Contractors
 and the Allied Trades of the Pacific
 Coast by The Architect and Engineer, Inc.

PUBLICATION OFFICE:

627-629 Foxcroft Building, San Francisco
 Telephone Douglas 1828

Portland office: 210 Stock Exchange
 Building, Portland, Oregon.

The publishers disclaim any responsibility for statements
 made in the advertisements of this magazine.

TERMS OF SUBSCRIPTION

(Including postage) to all parts of the United States \$2.50
 per annum; to Canada 75c additional; to all Foreign points
 \$1 additional

Vol. LXIV. March, 1921 No. 3

DRASTIC CHANGES TO BURNETT HOUSING LAW

Senate Bill No. 288, now before the California State Legislature at Sacramento, is attracting the attention of architects and builders throughout the State. If the amendments are passed the bill is likely to work some hardship on outside incorporated towns and cities, where enforcement of the provisions must necessarily be carried on under difficulties.

All restrictions now placed on the height of fireproof tenement houses and hotels will be removed if the bill becomes a law. Heights of semi-fireproof and wooden buildings will still be restricted according to the width of the street on which they are located. A wooden hotel or tenement house may have three stories with sleeping rooms or apartments over stores or other rooms not used for sleeping purposes.

The four-family flat building as now constructed, is not recognized in the

bill, a tenement house being defined as any building more than one story in height which is occupied by three or more families living independently of each other, without any qualification. All four-family flat buildings would have to conform to the regulations for tenement houses.

Smaller courts for hotels and tenement houses are provided for in the bill, the advantage thus given being greater for fireproof than for other types of buildings. Minimum widths of stairways and hallways is fixed at 3 ft. instead of 4 ft. The minimum floor area of a room is fixed at 80 sq. ft. instead of 90 sq. ft. as now required. Many other regulations in the existing laws are modified to the advantage of the owner.

In the codification of the three laws the regulations for dwellings are made State-wide in their application. The existing law applies only to dwellings erected in incorporated towns and cities. Thus a house built in the desert or in the mountains would have to comply with the same requirements as one built in a crowded city, if the bill became a law in its present form. The bill goes further than the present law in regulating the construction of dwellings in that it provides for the application of the Kidder standard for determining details of construction and requires that all floors shall sustain a live load of not less than 40 lbs. per sq. ft. and roofs shall carry a live load of not less than 20 lbs. per sq. ft.

Shingle roofs are apparently barred, not only from tenement houses and hotels but also dwellings. A building is defined by the bill as either a tenement house, hotel or dwelling. Sec. 68 provides that "every semi-fireproof building or wooden building hereafter erected shall have the roofs thereof constructed and covered and maintained in good repair with materials in this act as hereinbefore provided for semi-fireproof buildings." Sec 10, defining a semi-fireproof building, says "the roof shall be constructed of approved incombustible materials or covered with an improved composition fire resistive or fire retardent material."

Defining a wooden building the bill says that it "may be constructed of wood or stuccoed or veneered on wooden framework." Just what this may mean will probably be disputed by different authorities. "Veneered" may be a very broad or a very technical term. A dwelling is a building as defined by the bill but the only specific requirement for a dwelling is that it "shall be constructed in a substantial manner." It would appear that a tent house could not be constructed under the proposed law, especially in view of the requirement as to roof loads. Some persons might contend that a board and batten dwelling, commonly termed a "California house," could not be built, but it is not probable the law would be so construed.

THE HUGE WASTE IN TAX-GATHERING

The statement has been made by one in a position to know that for every dollar that reaches the United States Treasury now in the way of excess profits taxes, four or five dollars are collected from "you and me and the man in the street." That is, the American people as a whole, rich and poor alike, are paying a bulk sum four or five times as large as the government is receiving for the purpose of meeting our public obligations.

The collection of income and excess profits taxes is an enormously costly thing. The machinery is vast and cumbersome that the government uses to determine and collect these taxes. Thousands of men and women are taken from productive employment to man this machinery.

But this is only a part of the waste. There must be added the time and expense of the taxpayers in making out reports, reports so detailed, intricate and manifold that they call throughout the nation for the services of many thousands of clerks, accountants and lawyers, and for many hours of the time and thought of business men.

All these things mean increased prices to the community in many ways. First: The actual cost of clerk hire, accountants, lawyers, etc., is added to the cost of the product. Second: Na-

tional productivity is diminished. To quote a nationally recognized authority on this subject: "If to the actual cost, direct and indirect, incurred by the government in the collection of the income and excess profits taxes there were added the incidental expense to individuals, firms and corporations, the aggregate would be nothing less than staggering in its magnitude."

The thing to be borne in mind is that the ultimate consumer pays practically all of the taxes imposed in any way that affects the cost of production. We may cry "tax the rich" as loudly and insistently as we please, but when we tax the rich unjustly or out of proportion to the public charge they should be called upon to bear, we tax the poor also, in the way of added cost for the necessities of living.

But when we contemplate a system of taxation that aims to raise a billion dollars for government use, and which costs the people of this country five billions of dollars before the government uses it, it is time that we were raising an insistent and unanimous cry for something in the way of taxation more in keeping with reasonableness, fairness and justice.

A turn-over tax, or tax on sales, offers a way out, declares the Valve World. The cost of collection would be comparatively small. The tax itself would be comparatively insignificant. The aggregate collected would be ample. The quickest and surest way to reduce the cost of living is to adopt better methods of taxation, cut out the tremendous waste and inequality of the present system, pay our taxes as we transact our daily business, and free thousands of at present non-productive workers for our urgently needed increase in production.

Notes and Comments

Mr. John Young, Chief of the Portland, Oregon, fire department, has ordered that all rusty fire escapes in the city be repainted at once; that unless this is done many owners will be required to replace their fire

**A Lesson that
Should Be Heeded**

escapes when inspection time rolls around.

This is merely a recognition of the fact by the fire department that rust weakens and renders unsafe, metal structures; that deterioration results from failure to keep them painted.

Isn't it strange that owners of buildings should be compelled by official edict to preserve their properties from decay?

Will they take their lesson to heart? Will they realize that uncovered pillars, beams, posts, roof supports and other metal structural parts of their buildings will deteriorate just as surely as their fire escapes, if not kept protected by paint?

If labor accepts reasonable readjustments in wage scales there is no reason apparent why investors should not seriously consider going forward with projects which have been held back because of the high cost of building in the past two years, and that without further delay.

According to Mr. James R. Ralph, a Minneapolis builder, sixteen important building materials showed an average reduction of 23.5 per cent up to February 1, itemized as follows: Structural steel, 10 per cent; galvanized sheets, used in fire doors and cornices, 20 per cent; prepared roofing, 25 per cent; tar and gravel roofing, 15 per cent; cement, 25 per cent; steam fittings, radiation and boilers, 20 per cent; common lumber, 40 per cent; maple flooring, 40 per cent; birch finish, 30 per cent; oak, higher grades of interior finish, 30 per cent; hardware except lock sets, 10 per cent; nails, 20 per cent; reinforced steel, 9 per cent; soil pipe, 40 per cent; plate glass, 30 per cent; lead and oil, 10 per cent.

"In addition to these changes," said Mr. Ralph, "reduction in common brick prices by 20 per cent is confidently predicted before spring, and a 10 per cent reduction in metal lath, lime and plaster. Enamelware is off 10 per cent, but this commodity made very little advance in the last two years."

Apartment House Owners Protest

To protest against the high cost of building material, the apartment house owners and managers of California have organized a State Association, with Mr. H. Fredericks of Oakland as president.

The following resolutions have been drawn up:

WHEREAS, On account of the present shortage of housing accommodations in the State of California, due to the crowding into the larger cities and the lack of new construction; and

WHEREAS, The only practical solution is more building to relieve this shortage, therefore be it

RESOLVED, By the Apartment House Association of California in annual convention assembled that we urge upon the Governor and the Legislature of the State to co-operate in securing legislation which will encourage investment in new housing construction in California with particular reference to:

(1) The prevention of unlawful conspiracies and combinations to raise the price of building material.

(2) Encouraging savings banks to devote as large as possible a portion of their deposits and insurance companies to place as large as possible a portion of their premiums collected within the State for investment in building loans; and be it further

RESOLVED, That we recognize that in order to secure more building to relieve the existing housing shortage, it is necessary that reasonable returns be secured on the value of apartment house properties but that we are opposed to any rental charge that will produce more than such reasonable returns on the value.

How Building Prices Have Dropped in One Year's Time

An interesting example, showing how the cost of construction has dropped since a year ago, is to be found in the bids recently received by Architect A. A. Cantin of San Francisco, for the construction of a high school building at Martinez, Contra Costa county, California. The bids show that brick construction costs seventeen per cent less today than a year ago, while concrete is fourteen and one-half per cent cheaper. The following comparative table could be used by architects and contractors who wish to enforce the advantage of building now. These bids include plumbing, painting, hardware, electric wiring and lockers, all taken on practically the same set of plans:

	March 5, 1920	May 21, 1920	March 3, 1921
CONCRETE.....	\$145,787	\$148,508	\$126,916
BRICK.....	153,627	160,471	133,000

Certificates to Practice

The following have been granted certificates to practice architecture by the Southern District, State Board of Examiners:

Mr. William F. Bowen, 521 Union League building; Mr. Sumner M. Spaulding, with Mr. Myron Hunt, 1107 Hibernian building; Mr. F. M. Haskell, with Mr. J. Cyril Bennett, Pasadena; Mr. Joe M. Estep, with Mr. A. R. Kelly, 1201 Van Nuys building. Mr. A. H. McCulloh, Walnut Park; and Mr. William Bordeaux, with Messrs. Walker & Eisen, Pacific Finance building.

With the Architects

Building Reports and Personal Mention of Interest to the Profession

Julius Krafft & Sons Busy

The firm of Julius Krafft & Sons, Phelan building, report that much new work is coming into their office, due they think to the falling prices in building materials. The new Wellman Peck building on the Embarcadero, construction of which was postponed a year ago on account of the high prices, is to go ahead, and Hannah Bros. have been given the contract on a percentage basis. The building will probably be seven stories high. The same architects have prepared plans for alterations and additions to the residence of Mr. M. Ehrman, 2680 Jackson street, San Francisco, and plans also have been made for the completion of the third floor of a three-story frame apartment house at Fell and Ashbury streets, San Francisco.

Architect Clausen Has Much Work

New work in the office of Mr. C. O. Clausen, architect in the Hearst building, San Francisco, includes a \$32,000 frame apartment house to be erected on the northeast corner Fifteenth avenue and Cabrillo street; a two-story rectory at 1350 Waller street for All Saints Church; four flats at Twenty-sixth avenue and Cabrillo street for Mr. A. Harrington, to cost \$16,000; a flat building on Seventeenth avenue, Richmond District, and a residence in the same neighborhood, both to cost \$10,000 and a residence flat building for himself in the Richmond District, to cost \$18,000.

Designing Receiving Hospitals

Mr. Slack W. Winburn, architect of Idaho Falls, Idaho, and Mr. James L. Chesbro of Salt Lake City, associate architect, have been commissioned to prepare plans for two receiving hospitals for the State Insane Asylums of Idaho. They will be 32x122, three stories and constructed of reinforced concrete. One will be built at Blackfoot and will cost \$108,000, and the other at Orofino, and will cost \$105,000.

Will Design Fresno Theatre

Messrs. Weeks & Day, architects in the Phelan building, San Francisco, have been commissioned to prepare plans for a \$200,000 theatre at Fresno, for Mr. John Ellsbach. The playhouse will be leased by the Loew Theatrical Syndicate.

Berkeley Fraternity Houses

Mr. E. G. Bangs, architect with Mr. John Galen Howard, First National Bank building, San Francisco, has completed plans for a brick Fraternity House on Bancroft way, near College avenue, Berkeley, for the Sigma Nu Society. It will cost \$35,000.

The Delta Kappa Epsilon Fraternity of the University of California has purchased the Frank Woodward house at Piedmont avenue and Bancroft way, Berkeley, for \$100,000, and it will be extensively remodeled.

Sacramento High School

Plans are practically completed and bids will be called for within the next few days for the construction of a two-story brick and concrete high school building at Sacramento at an estimated cost of \$650,000. Mr. Edgar A. Mathews, Call-Post building, San Francisco, is the architect.

Hotel for Merced

Plans have been prepared by Mr. J. I. Mitrovich, 1034 Golden Gate avenue, San Francisco, for a five-story reinforced concrete two-hundred room hotel to be built at Merced for Mr. L. Francher and associates. The new hostelry will cost in the neighborhood of \$250,000.

Bank Building Contract

Contract for the construction of a one-story concrete and terra cotta bank building for the First National Bank at Pittsburg has been awarded to Messrs. Barrett & Hilp of San Francisco, for approximately \$21,000. E. L. Norberg is the architect.

San Jose Architects Busy

Messrs. Wolfe & Higgins, Auzerais building, San Jose, report that they have twenty-four jobs for which plans are being prepared or completed. Most of the work is for residences, varying in cost from \$6500 to \$20,000.

Another San Francisco Theatre

The Schubert-Curran Theatrical Interests will build a \$400,000 playhouse on the lot adjoining the Columbia Theatre, Geary street, near Mason. Plans are being prepared by Mr. Alired Henry Jacobs.

Designs Three Apartment Houses

The firm of Shirmer, Bugbee Company of San Francisco and Oakland, has recently completed plans for three new apartment houses, construction of which has been ordered by the owners. The largest building of the three will cost close to \$100,000, and is for Mrs. P. C. Renaud of 315 E. 19th street, Oakland. The building will face Lake Merritt and Wayne avenue, and will contain 24 high class three and four-room apartments. The two other buildings designed by this firm are to cost \$18,000 and \$25,000 each, and will be of frame and plaster construction.

Berkeley Architect Busy

Mr. James W. Plachek, Berkeley architect, reports that business has taken a turn for the better and that he expects to have more than \$100,000 worth of new construction work under way before May 1. Plans are finished for a \$20,000 store building on University avenue, west of Shattuck, for Mr. W. K. Acheson, and contracts will be awarded shortly for a large fire-proof warehouse for the Pacific Spring Bed Company of West Berkeley.

To Build Flour Mill

The Fisher Flouring Mills Company, 514 Hoyt street, Portland, Oregon, and 618 Merchants Exchange building, San Francisco, is having plans prepared for an \$800,000 flour mill at Portland, under the supervision of Grant Smith & Company, Flood building, San Francisco.

Reedley High School Group

The citizens of Reedley, Fresno county, have voted \$450,000 for a group of high school buildings for which plans are being prepared by Mr. Norman F. Marsh, 211 Broadway Central building, Los Angeles.

Concrete Apartment House

Mr. Chas. A. Monroe will build a four-story reinforced concrete apartment house on Geary street near Hyde, San Francisco, from plans by Mr. August G. Headman, Call-Post building. Bids have been taken and contracts will be awarded shortly.

Stockton Theatre and Lodge Building

Contracts have been let from the office of Mr. Ralph P. Morrell of Stockton, for the construction of an Odd Fellows Fraternity building in that city, at a cost of more than \$100,000. The ground floor will contain a moving picture theatre.

Architect Partner Wanted

EXPERIENCED ARCHITECT and structural engineer having had offices in five western states, good designer, wishes to form a partnership with some local architect practicing in San Francisco. Address, Box A, this office.

Oregon Architects Entertain

Mr. Henry H. Kendall, president of the American Institute of Architects, and Robert D. Kohn, a director, were Portland visitors in February, and were given a diversity of entertainment.

A luncheon at the Chamber of Commerce was attended by 48 representative contractors, material dealers, labor officials and architects. Mr. Kendall made but a few remarks because of a bad cold and was followed by Mr. Kohn, who pointed out conditions as they existed in New York and the difficulties the building crafts were attempting to overcome. He suggested that all the crafts get together and show a more willingness to co-operate.

Mr. W. G. Purcell, president of the Oregon Chapter, A. I. A., presided.

The Portland Chapter entertained with a banquet at the Benson Hotel in the evening, and about 25 members were present.

New Hotel for Denver

Denver is to have a new hotel embodying all the luxurious appointments of the finest hosteleries in the country, according to the plans of the Ritz-Carlton Realty Company, of which Mr. H. W. Bennett is one of the principal stockholders. The building will occupy a 300-foot frontage along Broadway and Lincoln streets and 266 feet along Seventeenth avenue. It will be ten stories high, and will cost \$6,000,000.

University Hospital

Mr. Curtis Tobey, 822 Security building, Los Angeles, has been commissioned to prepare plans for the new hospital buildings to be erected on E. Washington street, between Maple avenue and Trinity street for the University Hospital, Medical College and Clinic Corporation. It is expected that actual construction will be started by July 1. The initial improvements will include three buildings to cost \$1,000,000.

Washington Chapter Officers

Mr. Charles Alden of Seattle has been re-elected president of the Washington Chapter of the American Institute of Architects.

Other officers elected are: First vice-president, D. J. Myers, Seattle; second vice-president, A. J. Russell, Tacoma; third vice-president, H. C. Whitehouse, Spokane; secretary, Harold O. Saxsmith, Seattle; treasurer, Carl Siebrand, Seattle; director, J. S. Cote, Seattle.

Sacramento Bank Building

Construction will probably start within thirty days on the proposed eighteen-story Class "A" bank and office building at Seventh and K streets, Sacramento, for the Sacramento San Joaquin Bank. The plans for this \$1,250,000 structure have been completed by Messrs. Weeks & Day, Phelan building, San Francisco.

Guests of Institute Architects

Mr. Henry H. Kendall, president of the American Institute of Architects, and Mr. R. D. Kohn, a director of the Institute, were the guests of honor at a St. Valentine's Day banquet given in the Blue Room at the Los Angeles Athletic Club by the Southern California Chapter of the American Institute of Architects.

The visitors were welcomed to the city by Mayor Snyder who enumerated a few of the assets of Los Angeles and Southern California but deplored an utter lack of civic architecture. "Our city hall," he said, "was erected for a city of only 50,000 population and we have now grown to over 700,000, the tenth city in the United States. I never invite visitors to our city hall. The only other municipal building we possess is an antiquated city jail and I sincerely hope our guests will not see this building."

President Kendall spoke of the aims and purposes of the Institute and told of the work it is accomplishing through its committees and member chapters. Mr. Kohn talked on the service that an architect, through his training and experience, is prepared to render and should render to the public. The meeting closed with an address by John W. Mitchell, president of the municipal art commission.

Additions to Office Building

Messrs. Reid Bros., California-Pacific building, San Francisco, have been commissioned to prepare plans for an eighteen-story addition to the Class "A" office building at Sixth and Market streets, San Francisco, owned by the Western States Life Insurance Company. The latter has purchased an adjoining lot, which will give 80 feet additional frontage on Sixth street, and 78 feet frontage on Stevenson street. The improvements will cost \$800,000.

Appointed Architect of School

Mr. G. A. Applegarth, Claus Spreckels building, San Francisco, on recommendation of City Architect John Reid, Jr., has been appointed architect of the proposed new Emerson school building on Pine street, between Scott and Divisadero streets, San Francisco.

Los Angeles Mercantile Building

Messrs. Morgan, Walls & Morgan, Van Nuys building, Los Angeles, are preparing plans for a five-story Class "A" reinforced concrete mercantile building to be erected on Spring street, Los Angeles, for Mr. George H. CUTTS.

Apartment House

Messrs. O'Brien Bros., 240 Montgomery street, San Francisco, have let a contract to Wm. Martin to build a three-story apartment house at Duboce avenue and Pearl streets, San Francisco, at a cost of \$40,000.

Institute Admits Architects

The Executive Council of the Architectural Institute of British Columbia after examination sessions lasting two days in the middle of January, passed and approved for full membership in the Institute the names of thirty-two well-known architects, who have been granted certificates under the provisions of the Architectural Profession Act, passed at the last session of the Legislature. The executive council of the Institute which conducted the examination, consists of President A. L. Mercer; Vice-President, C. Elwood Watkins; Honorary Secretary, Fred L. Townley; Honorary Treasurer, S. M. Everleigh; committee, Prof. E. G. Matheson, R. P. S. Twizell and Percy Fox, Victoria. Individuals and firms admitted to membership are:

Vancouver members—Gardiner & Mercer, Twizell, Birds & Twizell, MacKenzie & Bow, Enoch Evans & Son, Honeyman & Curtis, Townley & Matheson, S. M. Everleigh, J. E. Parr, A. E. Henderson, J. A. Benzie, B. C. Palmer, A. A. Cox, Edwardes Sproat, H. W. Postle, H. H. Simmonds, Hugh Stewart, F. A. A. Barrs, W. F. Jones, R. T. Garrow, Bowman & Cullerne, W. F. Gardiner, Robert Lyon, J. C. Day, W. C. F. Gillam, Allan Menzies, S. A. Kayll, R. T. Perry, Frank Mountain, Franklin Cross, William Haldane, Sharp & Thompson, G. Rider Morris, F. W. Macey, Arthur J. Bird, Ross Lort, H. H. Gillingham, W. M. Dodd, Robert Wilson, John Y. McCarter, W. T. Dalton, R. W. Chadney, Robert C. Kerr, H. S. Griffith, Theo. Korner, Bernard Shrewbrooks.

Other Western points—Bell & Curtis, Vernon; Douglas James, Duncan, V. I.; H. L. Swan, Penticton; P. N. Corby, Regina; G. C. Nairne, Seattle, Wash.; L. L. Pearson, James Island; John McIntyre, Powell River; Henry Wilson, Prince George; W. H. MacAulay, Kamloops; O. B. Hatchard, Vernon; Blackadder & Mackay, North Vancouver; A. P. Augustine, Penticton; H. W. Cockrill, North Vancouver; C. A. Broderick, Trail; J. W. Potteram, Prince Rupert; J. B. Henderson, Calgary, Alta.

Victoria members—Messrs. C. Elwood Watkins, Percy Fox, Henry Whittaker, P. Leonard James, Dermott H. Barry, L. W. Harzeaves, W. Ridgway Wilson, Samuel Maclure, K. B. Spurgin, J. C. M. Keith.

Honored by School Association

Mr. J. W. Fricke, associate editor of this magazine, and well known as president of the C. F. Weber Company, San Francisco, Los Angeles and Phoenix, Arizona, recently returned from the East, where he attended the annual meeting of the National School Supply Association. Mr. Fricke was elected a member of the executive committee and was further honored by being made chairman of the Trade Relations Committee. He was congratulated by the Convention for his valuable work on the Executive Board last year.

Mission Play Theatre

Mr. Arthur B. Benton, 1548 Sunset blvd., Los Angeles, has prepared plans for a new theatre, concession building, Indian village, etc., and which are to be the permanent home of the Mission Play. The buildings, construction of which has been started, will be of adobe and concrete.

American Institute of Architects

(ORGANIZED 1857)

OFFICERS FOR 1920-21

PRESIDENT.....HENRY H. KENDALL, Boston
 FIRST VICE-PRESIDENT.....CHARLES A. FAVROT,
 New Orleans, La.
 SECOND VICE-PRESIDENT.....WM. B. FAVILLE,
 San Francisco
 SECRETARY.....W. STANLEY PARKER, Boston, Mass.
 TREASURER.....D. EVERETT WAID, New York

San Francisco Chapter

PRESIDENT.....G. A. APPLGARTH
 VICE-PRESIDENT.....EARNEST A. COXHEAD
 SECRETARY-TREASURER.....J. S. FAIRWEATHER
 DIRECTORS
 SYLVAIN SCHNAITTACHER, for three years.
 MORRIS M. BRUCE, for three years.
 GEORGE W. KELHAM (to fill the unexpired term
 of Mr. Wm. Otis Raiguel, resigned).

Southern California Chapter

PRESIDENT.....EDWIN BERGSTROM
 VICE-PRESIDENT.....HENRY F. WITHEY
 SECRETARY.....R. GERMAIN HUBBY
 TREASURER.....ROBERT H. ORR
 Executive Committee
 A. M. EDELMAN D. C. ALLISON S. B. MARSTON

Portland, Ore. Chapter

PRESIDENT.....W. C. KNIGHTON
 VICE-PRESIDENT.....JOHN V. BENNES
 SECRETARY.....FOLGER JOHNSON
 TREASURER.....O. R. BEAN
 TRUSTEES.....ELLIS F. LAWRENCE
 JOSEPH JACOBBERGER

Washington State Chapter

PRESIDENT.....CHARLES H. ALDEN, Seattle
 1ST VICE-PRESIDENT.....D. J. MYERS, Tacoma
 2D VICE-PRESIDENT.....A. J. RUSSELL, Tacoma
 3D VICE-PRESIDENT.....H. C. WHITEHOUSE, Spokane
 SECRETARY.....HAROLD O. SANSMITH, Seattle
 TREASURER.....CARL SIEBRAND, Seattle
 DIRECTORS.....A. H. ALBERTSON
 C. H. BEBB
 G. C. FIELD

California State Board of Architecture

NORTHERN DISTRICT

PRESIDENT.....CLARENCE R. WARD
 SECRETARY-TREASURER.....SYLVAIN SCHNAITTACHER

Members

J. R. MILLER EDWARD GLASS J. J. DONOVAN

SOUTHERN DISTRICT

PRESIDENT.....JOHN PARKINSON
 SECRETARY-TREASURER.....A. M. EDELMAN

Members

W. H. WHEELER MYRON HUNT W. J. DODD

San Francisco Architectural Club

President.....T. L. Pfeuffer
 Vice-President.....Wm. Watson, Jr.
 Secretary.....L. A. Bryant
 Treasurer.....Wm. K. Dunnavat
 Directors—Pas. Brouchoud, F. G. Monk, S. D.
 Willard.

San Francisco Society of Architects

President.....W. C. HAYS
 Vice-President.....LEWIS P. HOBART
 Secretary-Treasurer.....H. H. GUTERSON
 Directors.....GEO. A. LANSBURGH
 JOHN REID, JR.

Washington State Society of Architects

PRESIDENT.....HENRY H. JAMES, Seattle
 1ST VICE-PRES.CLAYTON D. WILSON, Seattle
 2D VICE-PRES.JULIUS A. ZITTEL, Spokane
 3D VICE-PRES.WATSON VERNON, Aberdeen
 4TH VICE-PRES.RICHARD V. GOUGH, Okanogan
 SECRETARY.....EGGAR BLAIR, Seattle
 TREASURER.....L. L. MENDEL, Seattle
 TRUSTEES—H. H. JAMES, FRANK FOWLER, A. WAR-
 REN GOULD, W. J. JONES, R. H. ROWE, all of
 Seattle.

American Society of Landscape Architects

Pacific Coast Chapter

PRESIDENT.....W. D. COOK, JR.
 H. W. Hellman Bldg., Los Angeles, Calif.
 VICE-PRESIDENT.....STEPHEN CHILDS
 Fairmont Hotel, San Francisco, Calif.
 SECRETARY-TREASURER.....E. T. MISCHE
 Henry Bldg., Portland, Oregon

Tacoma Society of Architects

PRESIDENT.....Roland E. Borhek
 VICE-PRESIDENT.....Earl Dugrud
 SECRETARY AND TREASURER.....A. J. Russell

San Diego Architectural Association

PRESIDENT.....WM. TEMPLETON JOHNSON
 VICE-PRESIDENT.....ROBERT HALLEY, JR.
 SECRETARY-TREASURER.....E. C. DECKER

San Joaquin Valley Ass'n of Architects

PRESIDENT.....E. B. BROWN
 VICE-PRESIDENT.....F. V. MAYO
 SECRETARY-TREASURER.....JOSEPH LOSEKANM

American Society of Civil Engineers

San Francisco Association

PRESIDENT.....M. M. O'SHAUGHNESSY
 1ST VICE-PRES.....W. L. HUBER
 2ND VICE-PRES.....F. R. MUHS
 SECRETARY AND TREASURER.....NATHAN A. BOWERS
 BOARD OF DIRECTORS
 W. L. HUBER

F. R. MUHS M. M. O'SHAUGHNESSY
 E. J. SCHNEIDER NATHAN A. BOWERS
 Address all communications to the secretary, 502
 Rialto Bldg., San Francisco.

Southern California Association

President.....H. W. Dennis
 First Vice-President.....R. J. Reed
 Second Vice-President.....F. D. Howland
 Treasurer.....E. R. Bowen
 Secretary.....F. G. Dessery
 DIRECTORS—H. W. Dennis, Ralph J. Reed,
 F. D. Howland, E. R. Bowen, F. G. Dessery, G. G.
 Anderson, W. K. Barnard.

Address all communications to Secretary F. G.
 Dessery, 619-20 Central building.

American Association of Engineers

PRESIDENT.....L. K. SHERMAN
 FIRST VICE-PRESIDENT.....H. O. GARMAN
 SECOND VICE-PRESIDENT.....A. B. MCDANIEL
 R. W. BARNES.....Portland
 FREDERIC BASS.....Minneapolis
 B. A. BERTENSHAW.....Cincinnati
 W. C. BOLIN.....Chicago
 RAYMOND BURNHAM.....Chicago
 C. E. DRAYER.....Secretary
 National Headquarters, 63 E. Adams St., Chicago

SAN FRANCISCO CHAPTER

PRESIDENT.....G. CHESTER BROWN
 FIRST VICE-PRESIDENT.....W. H. PHELPS
 SECOND VICE-PRESIDENT.....L. D. HOWLAND
 TREASURER.....R. E. DODGE
 SECRETARY.....F. T. AMWEG
 Permanent address, 960 Pacific Bldg.

LOS ANGELES CHAPTER

PRESIDENT.....CARL A. HEINZE
 FIRST VICE-PRESIDENT.....H. Z. OSBORNE, JR.
 SECOND VICE-PRESIDENT.....MYRON HUNT
 TREASURER.....E. H. MERRILL
 SECRETARY.....WILLIS S. PFEFFER
 Permanent address, 625 Metropolitan Bldg.,
 Los Angeles.

With the Engineers

Reports from the Various Pacific Coast Societies,
Personal Mention, Etc.

Code of Practice and Schedule of Fees for Structural Engineers

A PROPOSED code of practice and a schedule of charges for the use of members of the Structural Engineers' Association of Illinois has been prepared by a committee consisting of Messrs. Hugo Filippi, chairman; H. R. Bradley, I. F. Steru, J. N. Hatch and E. A. Rossiter. The code and schedule have been submitted to the members for discussion and action on their adoption will be taken at the next meeting of the association.

The proposed code of practice is as follows:

PROPOSED CODE OF PRACTICE.

In his relation to the client or to the public, the structural engineer should carefully preserve and maintain the responsibility and trust which has been reposed in him, ever bearing in mind that a violation of responsibility or trust manifests itself not only as a discredit to him, but casts serious reflection upon the entire profession.

In the relations between the structural engineer and a client, the engineer should be careful to so regulate his conduct as to preserve the dignity befitting the profession. Judgment should be reserved in all cases where a hasty, partially considered decision might result in loss to the client or reflect upon the engineer's professional ability. Acting in a judicial capacity between the client and a second party, he should act with the strictest impartiality, basing his final decision upon the true merits of the case, and under no circumstances should he permit any personal interests, either his own or those of his client, to influence his decision.

The profession of the structural engineer comprises undertakings of great responsibility, involving the welfare and safety of the public. The structural engineer is one whom the public may accept as eminently qualified to take this responsibility, and he should so establish himself as to preserve and maintain all that is implied by the Engineering Act. [Illinois state law for licensing structural engineers.—Editor.]

Code of Practice.—The following principles have been formulated for the purpose of establishing a standard to which all structural engineers can conform. A uniform observance of these principles is required to the end that no particular structural engineer or group of structural engineers shall profit by virtue of special privilege, but rather, having placed all structural engineers on a common basis, the success or failure of each will be determined solely by his professional ability and business acumen.

Professional Relations.—The relation between structural engineers should be one of strictest co-operation. No structural engineer should unjustly condemn the professional work or acts of another structural engineer, and any such unjust condemnation or criticism by a member of this association will render such a member liable to suspension from membership on the grounds of unprofessional conduct.

Expert Evidence.—Where a structural engineer has been engaged as an expert witness, he shall confine his testimony, so far as practicable, to the necessary exposition of facts, figures or engineering theory, as will permit the court or the jury to reach a fair and equitable decision.

Participation in Public Affairs.—This association puts itself on record as being heartily in favor of an active participation by its members in all public affairs, particularly those related to engineering.

The association believes that the tendency on the part of the municipality, the state and the government, of naming laymen only, on committees whose duty it is to investigate and report on matters of a technical or quasi technical nature should be so modified that at least a majority in the membership of such committees will consist of engineers.

The association asks its members to assist in the general dissemination of this principle and to spare no effort in securing this end.

Advertising.—This association stands committed to the belief that advertising, particularly in the form of business cards in technical magazines, is proper, and strictly professional, and that to discourage the same would be in direct contravention of good business principles. The structural engineer is urged to place suitable signs or placards on all structures, the design or construction of which are under his direction, and he should not hesitate to secure publicity in the press if the nature of his work justifies such a step.

He should, however, be careful to see that whatever press publicity he secures is of an impersonal nature, strictly barring all false claims or representations.

The association is not in favor of solicitation of business through the medium of circulars of a purely advertising nature and asks all of its members to refrain from this form of advertising.

Competition.—Members of this association are encouraged to enter competitions in a manner outlined under schedule of fees, particularly in the design of bridges and buildings. In this way the profession will be greatly benefited and good design stimulated.

No member of this association may either actively or passively enter into or become a part of any pool or clique, whose object it is to impair the honesty of any competition. A member of this association found guilty of such practice will be dismissed from membership on the grounds of unprofessional conduct.

A member of this association may not knowingly attempt to obtain any professional engagement already under negotiation by, or in possession of another structural engineer, except by the specific invitation of the client, and then only after ascertaining that there is good and sufficient reason for making the change.

Unfair Compensation.—A member of this association may accept compensation for service from one interested party only, except in the event that more than one party is involved, when additional compensation may be accepted, providing all parties interested, agree thereto.

No member of this association may receive, directly or indirectly, any royalty, gratuity or special fee, on any patented article or process used in the work upon which he is retained, without the consent of his client.

Co-operation.—All members of this association are urged, so far as circumstances will permit, to assist fellow structural engineers, by the exchange of general information and valuable experience, or by instruction through the engineering societies, the schools of applied science and the technical press.

Copyrights.—Copyrighting of plans, designs and specifications, with or without supporting design data, is strongly recommended by this association, and all members are urged to protect their work in this manner.

SCHEDULE OF FEES.

The proposed schedule of fees, representing the minimum fee to be charged, provides that the

charges for professional service may be based upon:

- (A) A per diem rate.
- (B) A retainer fee
- (C) A percentage of the cost of the work or
- (D) Actual engineering cost plus a fixed fee.

Per Diem Rate.—The charge for professional services, for consultations, studies, investigations, reports, and for expert testimony and preparatory work incident to law suits, shall be as follows:

(1) For short engagements on any of the above work, a minimum fee of \$100 per day shall be charged.

(2) For preliminary studies, for investigations and for reports, made to determine whether the engineer can support the claims of the client, as for example prior to a law suit, a minimum fee of \$50 per day shall be charged.

(3) For submitting a report and reviewing the design prepared by others for existing or proposed work, a minimum fee of \$100 per day shall be charged for the first week, \$75 per day for the next week, and \$50 for each day thereafter until the specified work is completed.

(4) The above charges are intended to cover professional services only, unless otherwise previously agreed to, and any expense incurred in connection with a specific engagement, such as transportation and subsistence, salaries paid assistants engaged on the work, office and field supplies, and general office expense, shall be charged the client in addition to the above fees.

A Retainer Fee.—(5) Where a member of this association has been retained for general advice by a firm or corporation, and said retainer is for a long term of engagement, he may accept such retainer at a compensation not less than that indicated in paragraphs (1), (2) and (3).

Percentages of the Cost of the Work.—(6) For preliminary examinations, studies and reports on new projects, or for review, study and reports on existing or pending projects previously dealt with by others, a minimum fee of 3 per cent of the cost of the work shall be charged.

Work under this head may be charged for under the terms of paragraphs (1 to 4 both inclusive) if preferable.

(7) For such investigations, plans and specifications as may be necessary to secure an intelligent bid from contractors, a minimum fee of 5½ per cent of the cost of the work shall be charged.

(8) For final working drawings and specifications, together with necessary consultation and general advice during construction, a minimum fee of 7½ per cent of the cost of the work shall be charged.

(9) For professional services, including preparation of final plans, specifications and contract forms, award of contracts, superintendence during construction, testing of materials and general supervision of the work, a minimum fee of 10 per cent of the cost of the work shall be charged.

(10) For professional services incident to engagements involving repairs or alterations to existing buildings or other structures, a fee of not less than 10 per cent of the cost of the work shall be charged.

(11) The percentages indicated in the above paragraphs under this head, shall be construed as applying to work not exceeding \$100,000 in cost. The minimum percentage to be applied on larger work shall be as follows:

Paragr.	\$100,000 to \$250,000. Per cent.	\$250,000 to \$500,000. Per cent.	\$500,000 to \$1,000,000. Per cent.	\$1,000,000 and upward. Per cent.
6	2½	2	1½	1
7	5	4½	4	3½
8	7	6½	6	5
9	9	7½	6½	5½
10	9	7½	6½	5½

(12) Paragraphs (6) to (11) both inclusive, are to be computed upon the total cost of the completed work, exclusive of engineering, or upon a bona fide estimated cost or bid pending the completion of the work, with an adjustment when the actual cost is known.

(13) The phrase, "cost of work" as used herein, refers only to such part or parts of the whole work or project for which the engineering has been engaged, clearly excepting, however, all buildings and other similar structures, for which the fee shall apply to the entire cost of the building, not including special machinery, lighting, heating,

plumbing or ventilation, unless these items require special consideration by the engineer, in which event the percentages shall be applied whole or in part to any or all of these items as circumstances may direct.

(14) The percentages indicated in paragraphs (6) to (11) both inclusive, include all the charges mentioned in paragraph (4) unless previously otherwise agreed to.

Actual Engineering Cost Plus a Fixed Fee.—(15) A member of this association may accept an engagement on this basis which contemplates a charge to the client to cover the salaries of assistants engaged on the work, and general office expense, with an addition of from 50 per cent to 100 per cent for overhead. In addition to the above, the charge to the client shall be increased for the professional services of the engineer, an amount equal to not less than 50 per cent of the fees indicated in paragraphs (6) to (11) both inclusive.

(16) It is recommended that all members of this association require of the client a written agreement stating clearly and fully the conditions of the engagement, the period during which the work is to be executed, the amount of remuneration to be paid the engineer, and the terms of payment thereof.

(17) Where changes in plans, specifications or contracts are required by the client after work has been commenced thereon, an additional charge may be made against the client, for making such changes at actual cost plus a percentage, as indicated in the first clause of paragraph (15).

(18) In the event that the project covered by an engagement is ordered abandoned upon instructions from the client, the fee which may be claimed by the engineer shall be determined by the progress made and the expenses and obligations incurred by the engineer.

No recommendation is made to cover this contingency, and all members are urged to reach a fair and equitable agreement with the client without recourse to legal proceedings or arbitration, unless unavoidable.

(19) Where an engagement has been accepted by an engineer with the expectation that an immediate start may be made thereon, and the work is delayed by the client, the engineer may ask for additional remuneration, if proceeding with the delayed work would entail an additional financial burden on him.

Are Engineers Unresponsive Citizens?

Mr. M. O. Leighton, Chairman of the Engineers, Architects and Contractors' Conference on National Works, writes the editor of Building Review, New Orleans, as follows:

"I heard something about engineers the other day from a great man, an acknowledged statesman, a high-minded politician, and a keen observer of people and events. His name, if I were permitted to tell it, would surprise every reader of this message. We were talking about our project for a National Department of Public Works. I am able to quote it almost verbatim because the words burned in as they were uttered:

Your task is appalling. You have been elected to lead engineers into a political reform. They are the most unresponsive citizens that we have. Your organization has a praiseworthy purpose but if it were sponsored by almost any other group of reputable men than engineers there would be more promise of success. If your organization succeeds I believe you will find that it will not be the engineers who have carried it through. Their aloofness and indifference in all matters outside of their own professional sphere are among the unexplainable things in our political life.

"That statement hurt. How many other public men have the same opinion? As it comes from a high authority, who is not given to loose talk, it seems wise to pass it on to the engineers of the country."

A Four-Room in One Apartment

ACUTE housing conditions in this country are receiving the attention of space saving experts. The regular type housing developments are planned with a view to relieving conditions. When the estimates are received the projects are abandoned because of the high cost of building. These costs fail to protect the investment for the owner as well as giving reasonable rentals to the tenants.

The U-Turn-It device as suggested in the plans shown herein is used for apartment houses, industrial housing and vacation or summer cottages, and offers a real solution to the housing problem. The system provides more apartments per square foot than any other condensed building system. This is an important feature when the cost of land and building is taken into consideration. The U-Turn-It device is practical, has approved plumbing, ventilation, fire protection, and easy operation features. Successful housing developments can unquestionably be had as The U-Turn-It is said to satisfy the health authorities, architects, builders, owners, and the occupants.

The U-Turn-It housing device is the invention of an architect of Buffalo, N. Y. The installation operates easily (like revolving doors entering into a building) and has been designed along modern lines. The floor base with a locking device is on a ball-bearing frame with three, four or more partitions of steel built upon it having a closet door on a side. These sides are equipped with parlor, bookcase, wall recess with counter balanced lift bed and stove. It has automatic ventilation at top and bottom of the bed and over the kitchen stove. The kitchen sink is connected with

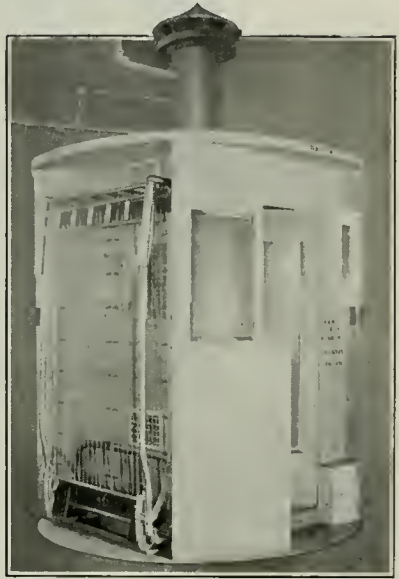

Bed and Dresser with Wardrobe Sides

hot and cold water, having tight revolving ground joints to the vent water and waste. Garbage is also ventilated and is self carried up to the roof with an independent flue, a completed ice box with its drain to the sink, ironing board, china and utensils, drawers and kitchen seat, besides a combination dresser and chiffonier, in connection with interior closet having wardrobe outfit, medicine cabinet and shoe polish outfits.

The room in which the installation is made is entered at one end on which sides



Electric Stove, Sink, Ironing Board, etc.

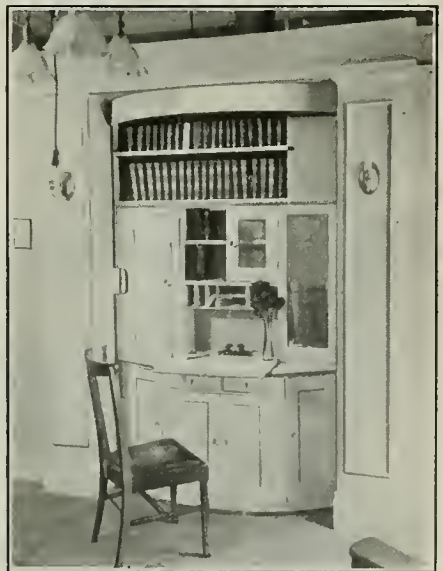

Library and Desk



*Textile Building, New York
Architects: Somerfeld & Stecker
Builders: Geo. Backer Const. Co.*



**—should be seen
but not heard —**

MODERN American business is a quiet, smooth-running institution. It houses itself in clean, light buildings, and guards its nerves with reliable, shock-absorbing devices.

An indication of this is the increasing number of new big buildings that are being equipped with quiet, free-swinging, ever-lasting

STANLEY BALL BEARING BUTTS

In the new Textile Building, Fifth Avenue, 30th and 31st Streets, New York, Stanley Ball Bearing Butts, B. B. 171, are used. Architects: Somerfeld and Stecker. Builders: George Backer Construction Co.

*"BUILDINGS YOU HAVE SEEN"
Sent Upon Request*

THE STANLEY WORKS

Main offices and plant: NEW BRITAIN, CONN.

Branch Offices:

NEW YORK CHICAGO SAN FRANCISCO LOS ANGELES
SEATTLE ATLANTA

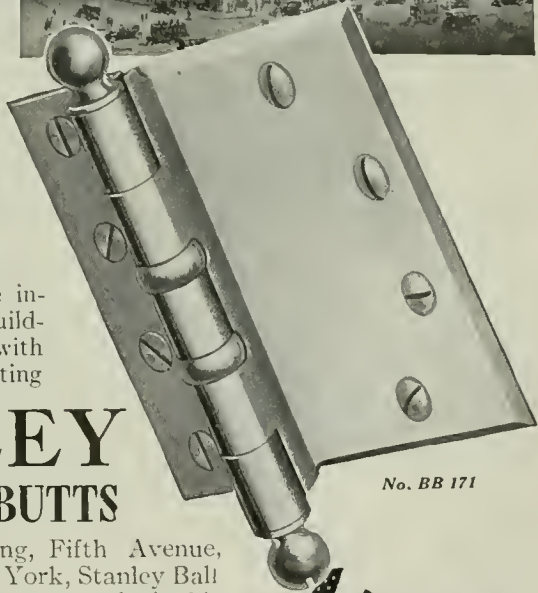

No. BB 171



*Did you see the February advertisement?
Here it is.*

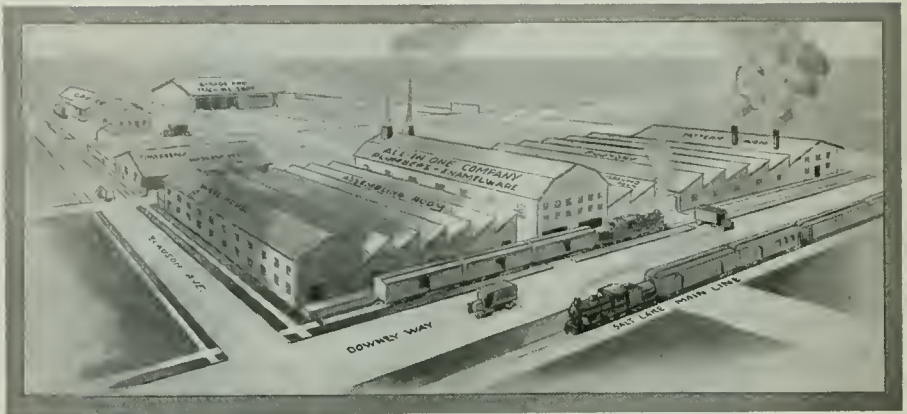

PROPOSED PLANT OF THE ALL-IN-ONE COMPANY, LOS ANGELES

Million Dollar Company to Manufacture New Patented Bathroom Fixtures

THE All-In-One Company, incorporated for one million dollars, will shortly commence construction of its \$250,000 factory on the Salt Lake railroad on Slauson avenue in Los Angeles, where it will manufacture a complete line of sanitary bathroom fixtures, including the All-In-One Bath tub, All-In-One Lavatory and other fixtures.

All-In-One fixtures are a decided departure from all other bathroom fixtures. They have a patented feature which eliminates all of the connecting joints of the old style tub and lavatory, there being only six slip joints necessary to install the All-In-One bathtub or lavatory. The inlet pipe, waste pipe, overflow integral and bath cocks are all cast with the fixtures. This means that there is only one connection to be made either in the floor or in the wall at the rear. This not only effects a saving in time and in the expense of installation, but makes for greater efficiency in the fixture and adds greatly to its appearance. All-In-One fixtures eliminate all metal parts, the entire fixture being in white enamel.

Signal success seems assured to the All-In-One Company as evidenced by the great interest indicated in its new fixtures by architects, building contractors and the plumbing trade in general, the company already having received orders in a volume sufficient to keep the factory busy for six months. The factory when completed, will be the most modern of its kind on the Pacific Coast. Two hundred men will be employed in the beginning with an output of 250 fixtures a day. The management of the factory will be in charge of an experienced foundry man who has been engaged in this line of work for the past thirty years and who, for the past seven years, has been superintendent for one of the large iron works in this State.

The architect has completed the plans for the factory and an announcement of the start of construction is expected daily.

Contractors' Convention

About 240 contractors from 28 states attended the annual convention of the Associated General Contractors of America at New Orleans, January 25 to 26, inclusive. President W. A. Rogers in his annual address emphasized the need of organization to compile data relating to industry that would be readily available. He expressed the belief that the association, in whatever it does, will always guard public interest.

At the session of the building contractors division, Mr. Godfrey Edwards of Los Angeles, participating in the discussion on forms of contract, objected to the cost plus fixed fee contract on the ground that the cost plus element in it permitted the contractor to pay more for his labor and material than could the contractor operating under a lump sum contract.

Folding Ironing Board

The Miller folding ironing board has recently been perfected and placed on the market by an Oakland concern. The board eliminates the wall cabinet and has no supporting leg. It requires no fitting and is rigid and steady. It is standard size—11¼ inches by 4 feet. It is installed in the lower part of a kitchen case, provision being made for it by the mill man without extra charge.

Modesto Phone Exchange

The Pacific Telephone Company's Engineering Department in the Sheldon building, San Francisco, is preparing plans for a three-story telephone exchange to be built in Modesto at an estimated cost of \$100,000.

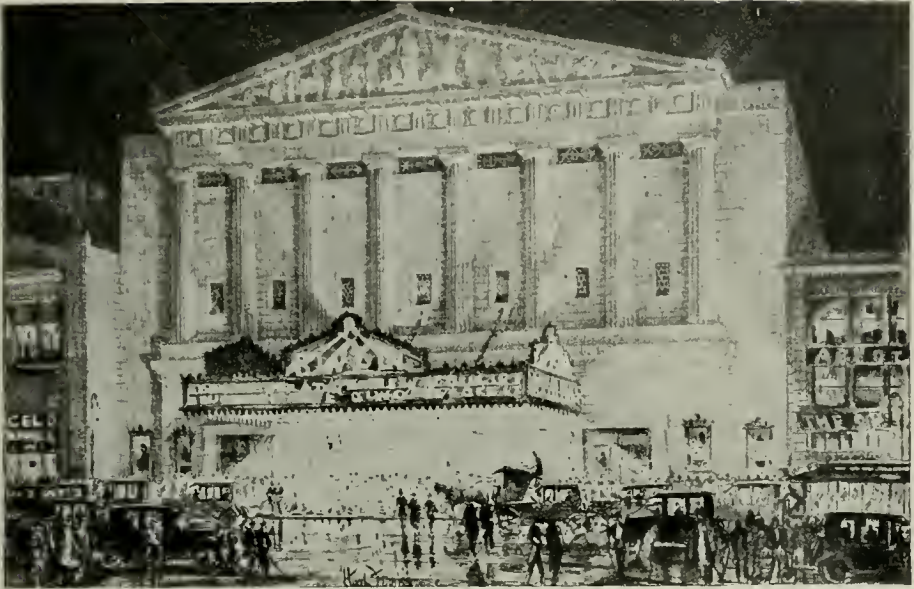

Copyright, 1920, National Terra Cotta Society

Drawing by Hugh Ferriss

RIVOLI THEATRE, NEW YORK CITY

Speckled gray Terra Cotta, tooled finish

THOMAS W. LAMB, Architect

P E R M A N E N T

PERMANENCE, the recognized ideal of the architect in ancient practice, is of equal concern to him today.

Of the materials with which he clothes his buildings he may demand color, texture, adaptability for ornament and unit design, and many other properties; and these he finds, in limitless variety, in Terra Cotta.

And with them, inherent in the basic properties of the material, he finds also *Permanence*, through Terra Cotta's time-proved resistance to fire, climate, weather and the disintegration of age.

The architect's inseparable partner in every building enterprise is the building public—to whom the story of Terra Cotta is being told each month by National Terra Cotta Society in the advertising pages of *The Literary Digest*, in a series of unusual advertisements which architects, and thousands of others, are reading with increasing interest.

In each of these advertisements the idea of *Permanence* is stressed—the permanence of Terra Cotta as a facing material, and the permanence of a building as an additional reason urging the layman always to employ an architect for this important type of creative effort.

NATIONAL TERRA COTTA SOCIETY is a bureau of service and information. Its publications cover not only the technical and structural use of the material but show, as well, examples of its application to buildings of various types.

Brochures of specific value, as indicated by their titles, will be sent to Architects on request addressed to National Terra Cotta Society, 1 Madison Avenue, New York, N. Y.

The School

The Theatre

The Garage

The Store

The Bank

These brochures consist of a selection of illustrations, with text and comment, showing Terra Cotta buildings of the respective types.

Terra Cotta—Standard Construction

A valuable Technical Reference Work for Architects and Engineers.

Terra Cotta Defined

This new booklet, intended primarily to inform the layman, will nevertheless prove interesting to Architects who like to review buildings the country over.

TERRA COTTA

Permanent

Beautiful

Profitable

New Liquid Floor Covering

"Koverflor" is the name of a new liquid floor covering in solid colors, being manufactured by the Standard Varnish Works, of New York, Chicago and San Francisco. This company has been manufacturing paints and varnishes for fully half a century, and its products are known and used extensively throughout the world. The San Francisco manager, Mr. Edward Millhauser, has been identified with the Standard Varnish Works nearly twenty years. Enthusiastic over the merits of this new product, and in explaining the merits of "Koverflor," he declares it is an evolution in floor treatment for both exterior and interior, wood and cement floors. Exposed to weather or hard usage, "Koverflor," he says, may be applied to kitchen floors with highly satisfactory results, as well as to porch floors, garage, hospital, lavatory, laundry, and in fact, any floor outside or in that has been subjected to hard wear or dirty usage. It makes an old floor look and feel like new.

"Koverflor," said Mr. Millhauser, "is a perfect floor covering scientifically prepared in solid colors for the preservation of exterior and interior floor surfaces of wood and cement. It combines attractive appearance, absolute protection, unusually long service and moderate expense.

"Koverflor" should not be confused with paint, varnish stains, lacquers, lac's, etc. It is distinctive. Its characteristics of extraordinary merit are to be found in its super-resistance to water, weather, oil, grease, dirt and extreme hard wear.

"There is no surface that undergoes such severe usage as wood and cement flooring and when not thoroughly protected, become impaired, unsightly and costly to restore.

"Koverflor" effectually does away with floor troubles. It is easily applied and dries sufficiently hard to walk on overnight.

"Imitation tile effects may be produced with 'Koverflor' by using patterns supplied for the purpose; full directions are given with each. The red and black are most favored where these effects are desired—other pleasing effects can also be produced."

Terra Cotta Brochure

The brochure series issued by the National Terra Cotta Society, One Madison avenue, New York, is a valuable contribution to modern architectural compilations. As illustrative of the uses and applications of terra cotta in architectural treatment of buildings and structures it should be most helpful and illuminating to architects, engineers, builders and owners. The series consists of six brochures: Vol. I, devoted to "The School," with 101 illustrations; No. II, "The Theater," with 110 illustrations; No. III, "The Store," 60 illustrations; No. IV, "The Bank," 78 illustrations; No. V, "The Garage," 67 illustrations; No. VI, "Terra Cotta Defined," 32 pages. The illustrations are representative of the best architectural work in all parts of the country. Volumes I to V will be sent free to those interested in the particular type of building mentioned and No. VI to all interested. A book of 160 pages illustrating terra cotta construction will be sent free to architects and engineers for professional use.

San Francisco Contractors Successful

Two San Francisco contracting firms have been successful in figuring Southern California work the past month. Messrs. Lange & Bergstrom submitted the low bid for the construction of seventeen buildings at the Naval Training Station, San Diego, at \$904,369, and also for the construction of a hangar at the U. S. Naval Air Station at San Diego for \$148,236.

The K. E. Parker Company has been awarded a contract on their bid of \$441,900 to construct a six-story reinforced concrete storehouse at the foot of Broadway, San Diego, for the U. S. Government.

Chinese Presbyterian Mission

Mr. L. M. Gardner, 942 Pine street, San Francisco, has completed plans and a contract has been let to Messrs. Barrett & Hilp, for approximately \$30,000 for a Class "C" Chinese Presbyterian Mission at Jackson and Stone streets, San Francisco.



A LIQUID FLOOR COVERING
For Outside and Inside Floors of Wood, Cement or Concrete
Standard Varnish Works

GENERAL OFFICE:
90 WEST STREET, NEW YORK
San Francisco Offices and Warehouse:
55 STEVENSON STREET

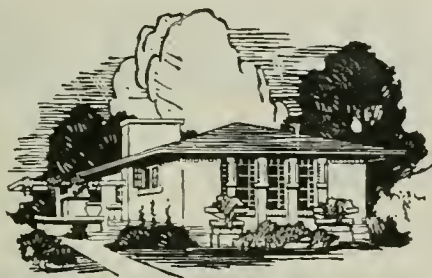

USE
CONCRETE
 FOR PERMANENCE

You don't have to repair or rebuild when you use concrete. It is permanent and grows stronger with age.

PORTLAND CEMENT ASSOCIATION

Atlanta				San Francisco
Chicago	Detroit	Los Angeles	Parkersburg	Seattle
Dallas	Helena	Milwaukee	Pittsburgh	St. Louis
Denver	Indianapolis	Minneapolis	Portland, Oreg.	Vancouver, B.C.
Des Moines	Kansas City	New York	Salt Lake City	Washington



BUILDING BUSINESS

CALIFORNIA'S OLDEST NATIONAL BANK HAS BEEN A VITAL FACTOR IN THE UPBUILDING OF SAN FRANCISCO AND THE ENTIRE WEST.

WHEN LAYING PLANS FOR THE FUTURE OF YOUR BUSINESS CONSULT THE OFFICERS OF THIS INSTITUTION

THE FIRST NATIONAL BANK OF SAN FRANCISCO

Affiliated with
FIRST FEDERAL TRUST COMPANY
 Combined Resources \$60,473,521.88

Marble for Soda Fountains

The adoption of prohibition naturally created an unprecedented demand for temperance drinks, and consequently it will surprise no one to learn that last year there was the greatest demand for soda water fountains and their accessories in the history of the trade. One of the leading manufacturers says:

We could not fill many orders we had taken last year on account of lack of supplies and labor difficulties. We had five cars of marble held up for three months, and a number of cars of the porcelain accessories for the fountains were lost entirely for several months. Then, where we had a hundred workers employed we were never sure any morning to find more than fifty or seventy-five. The men have money, and evidently a workman would say to Friend Wife, "Lets take a little jaunt in the flivver this morning and I will cut work." They do, and we have nothing to say about it.

Our white marble is from Italy, and we bought up everything we could find in the market during the war, foreseeing difficulties. The red marble is the Knoxville or Tennessee kind and the onyx Mexican, from Southern California. We have been getting small slabs, 2 and 3 feet square, practically discards, when we should have slabs of 6 and 8 feet, which we cannot get on account of transportation difficulties.

Mrs. Wiggs' Theory of Economics

The time devoted at the Montreal meeting of the American Federation of Labor to a discussion of the reduction of the working day to six hours in order to make employment go a little further, was evidently based on the theory of domestic economy practiced by Mrs. Wiggs of "Cabbage Patch" fame. When unexpected guests came to dinner and there was not enough soup to go around, she poured more water into it. The idea of a reduction of the work day is based on the same theory. —Monthly Bulletin, Illinois Society of Architects.

San Francisco Hotel

Mr. Clay N. Burrell, of Oakland, has prepared preliminary plans for a six-story reinforced concrete Greek hotel to be erected on Folsom street at an estimated cost of \$150,000. There will be one hundred rooms on the first five floors and a fraternal hall on the sixth floor.

ARTHUR BROWN

INTERIOR DECORATOR

212 Foxcroft Building
 SAN FRANCISCO



Fine Art
 Fabric Designs
 Domestic and
 Foreign Wall
 Hangings
 Japanese
 Grass Cloth

Telephone
 Kearny 5879



TRANSMISSION EQUIPMENT

For Mill or Factory

Pulleys - -	Shafting - - -	Gears - - -
Hangers - -	Bearings - -	Take Ups - -
Sprockets -	Clutches - -	Chain Belts -
Floor Stands	Bolt Tighteners	Rope Sheaves

Messico Short Center Drives

Messico & Gottfried Company

ENGINEERS AND MANUFACTURERS
 CONVEYING ELEVATING SCREENING
 AND MECHANICAL POWER TRANSMITTING
 MACHINERY

SAN FRANCISCO 660 Hayes Street	SEATTLE 558 First Ave. Co.	PORTLAND 67 Front Street	LOS ANGELES San Pedro E. 3rd St.
-----------------------------------	-------------------------------	-----------------------------	-------------------------------------

When writing to Advertisers please mention this magazine.

DEPENDABILITY

THE discerning architect or draftsman not only sketches *beauty* of design into his plans, but *writes* dependability of materials into his specifications for concrete or stucco construction — simply by the phrase, "ATLAS Portland Cement with ATLAS-WHITE for the finish coat."

On problems regarding the use of cement, the services of the Atlas Technical Department are at the disposal of draftsmen and specification writers.

THE ATLAS PORTLAND CEMENT
COMPANY

New York Boston Philadelphia Birmingham
Chicago Dayton Des Moines St. Louis

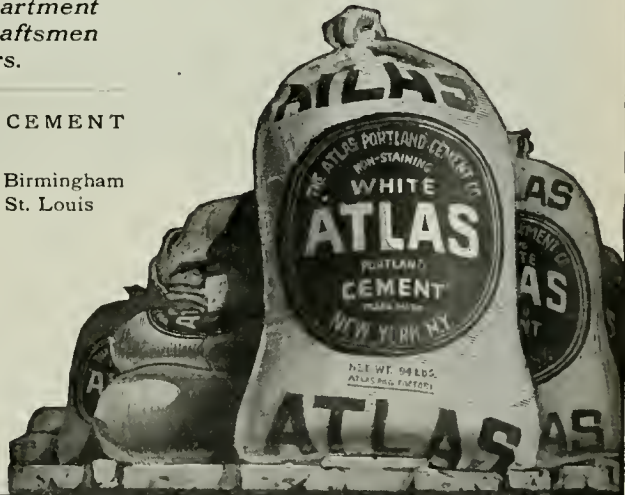

ATLAS WHITE

NATIONAL WINDOW SHADE COMPANY, Inc.



**HAND-
MADE**



**NATIONAL BRAND'S
WINDOW SHADES**



**RESIST ANY
WEATHER**

Phone Franklin 552

244 EDDY STREET, SAN FRANCISCO, CAL.

Agents for
BRENLIN
The Long Wearing
Window Shade
Material

National Shades wear
twice as long as the
ordinary kind

Gunn, Carle & Company Have New Warehouse and Business Offices

In January, 1906, when reinforced concrete construction was in its infancy in San Francisco and when The Architect and Engineer was advocating the use of this material in spite of objections from engineers and promoters of other types of building construction, the firm of Woods & Huddart was organized. Following the disastrous fire in April of that year, the firm was one of the first to resume business and its progressiveness proved a real service in the rebuilding of San Francisco. The first large reinforced concrete building to be erected following the fire was the structure now standing at Pine and Battery streets and known as the Exposition building. It is owned by the Boyd Estate. Completion of this structure was followed by the erection of the American Biscuit Company's factory at Battery street and Broadway, from plans by the late architect, Mr. Ralph Warner Hart. Both of these structures are reinforced concrete with steel bars furnished by Messrs. Woods & Huddart. Another early structure supplied with steel by this firm is the Granada Hotel on Sutter street.

Originally this firm dealt only in reinforcing steel, oil well casing, merchant pipe, piping for water works and new and relaying rails. Other lines have been added from time to time, however, so that today, in addition to hadling the products enumerated above, this firm carries: Steel mill and foundry supplies; pig iron; ferro alloys; commercial minerals; industrial equipment; industrial trucks, tractors, cranes; electric furnaces, foundry equipment, electric furnace supplies; electrodes, refractories; hydratite for waterproofing concrete and hornstone for hardening concrete.

In 1915, Mr. C. M. Gunn, formerly president and manager of the Columbia Steel Company, became a member of the firm.

In 1917, Mr. C. M. Woods withdrew in order to devote himself exclusively to oil well equipment. The firm continued under the name of Woods, Huddart & Gunn until the death of Mr. Huddart in 1919, when the latter's interest was purchased by Mr. Gunn

and Mr. Chas. W. Carle, the latter having been associated with the firm since 1907 as sales engineer.

In January, 1919, the firm of Gunn, Carle & Company was incorporated, with Mr. Chas. M. Gunn, president; Mr. Chas. W. Carle, vice-president, and Mr. E. H. Swing, secretary. By the beginning of the following year the company had erected and were occupying a modern reinforced concrete warehouse at Tenth and Bryant streets, embodying the very latest equipment for handling steel and supplies. The building is located on a spur track and is equipped with overhead traveling crane running over and serving incoming and outgoing cars. The crane spans the entire building and serves any point of the warehouse with one handling.

Some of the more recent buildings in which the firm has furnished and installed reinforcing steel are:

- Aetna Life Insurance building, Pine street near Montgomery.
- Realty Exchange building, Pine street near Montgomery.
- American National Bank building, Montgomery and California streets.
- C. C. Moore building, First and Mission streets.
- National Carbon Company building, Eighth and Brannan streets.
- National Lead Company's plant, Melrose, Calif.
- Mason By-Products plant, Sausalito.

Gunn, Carle & Company installed the steel in a great number of commercial garages in San Francisco, one of the largest being the Century Garage on Post street, near Taylor, San Francisco; also the new automobile warehouse and show rooms for the William L. Hughson Company, now being erected at Eleventh and Market streets, and the U. S. Post Office Garage on Beale street. Fourteen theatres in San Francisco and vicinity are included in the list of buildings this company has supplied with steel.

The steel has been installed by this firm in many apartment houses, both of large and modest dimensions, the Stanford Court apartments being of the former class, and the Chickering Apartments of the latter.

In the industrial line possibly the most notable features handled are the Baker electric industrial tractors and trucks; Service lift trucks, tri-wheel and quad-wheel trucks; Service casters for use in ware-



PRESTIGE

BOOKS — advance agents of character — will dominate home or office with an atmosphere of your choosing.

¶ Let the bookcase be in as strikingly good taste and as strongly reflect the dignity and prestige of the establishment. The difference is appreciable.

H S. CROCKER CO., INC.

565 MARKET STREET, SAN FRANCISCO
Los Angeles Sacramento Oakland



OFFICE OF PRESIDENT AND VICE-PRESIDENT, GUNN, CARLE & CO.



GENERAL OFFICES, GUNN, CARLE & CO., SAN FRANCISCO



AUTO TRUCK BEING LOADED BY ELECTRIC CRANE
Gunn, Carle & Co. Warehouse
San Francisco

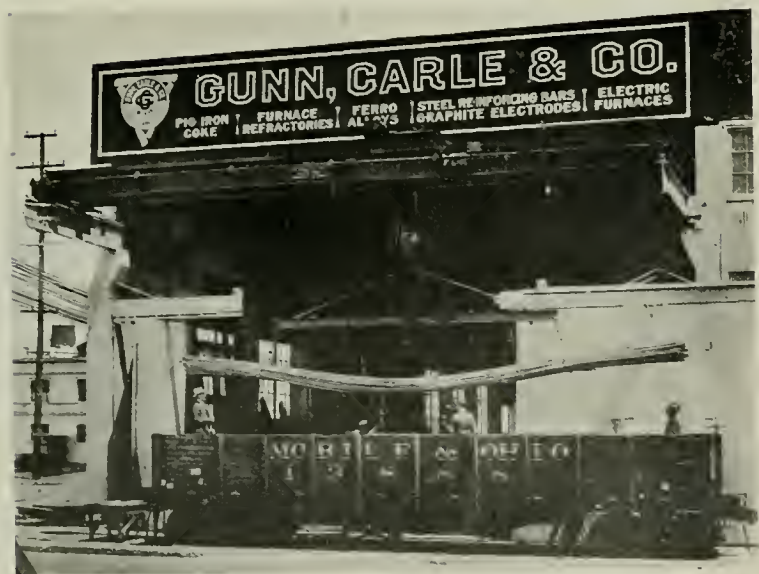

SPUR TRACK, OVERHEAD CRANE AND CAR LOAD
Gunn, Carle & Co. Warehouse
San Francisco

houses, bakeries, laundries and various industrial plants.

The offices of the company, in the Board of Trade building, 444 Market street, San Francisco, of which photographs are shown, are thoroughly modern, embracing a construction department with engineering and drafting rooms, industrial department, export department, accounting department and office of president and vice-president.

E. A. White Heads Agricultural Engineers

The election of Mr. E. A. White as president of the American Society of Agricultural Engineers carries incidental interest to the older friends of the society because it has been pointed out that every charter member of the society now living has come to its presidency. Mr. White, or Dr. White as he is known among those who hold worth while the honors arising from scholarship and research, holds a doctor's degree in agricultural engineering from Cornell University. This is believed to be the first and only degree of its kind ever granted in America, and bears testimony to a high order of engineering skill and research ability.

Mr. White's research work at Cornell was devoted largely to the moldboard plow and resulted in the establishment of a working theory and a mathematical way of expressing in three algebraic terms the shape of any successful moldboard plow. It may be said that Mr. White probably has done more than any other man in America to bring plow design from an art to a science.

Sacramento School Program

Sacramento is having splendid success with its school program. Thus far contracts have been let to general contractors for two schools, and plans have been accepted for two more buildings. The bidding on the buildings has been lively, and in each case the bids have been considerably under estimates. The architectural work is in the hands of Messrs. Hemmings, Petersen & Hudnutt, and the head of the drafting department is Mr. Dean, formerly with the State Architect.

San Francisco Building Permits Show Gain for February

	—February—	
	1921	1920
San Francisco	\$3,126,581	\$2,330,395
Los Angeles	3,131,670	3,286,415
Oakland	966,203	921,502
Sacramento	266,867
San Diego	909,775	138,977
Fresno	189,650	594,000
Stockton	115,930	143,750
San Jose	114,365	173,660
Pasadena	298,706	195,408
Long Beach	1,011,143
Santa Rosa	79,727
Modesto	69,845

To Architects:

It certainly is logical to presume that if a Contractor were furnished a *bill of quantities* on a particular piece of work and that said Contractor was *guaranteed* that the bill of quantities was sufficient to complete the work; that this would eliminate one of the risks of contracting; and obviate the addition of a percentage to his bid to cover this contingency.

This is what the Planing Mill Listing Bureau is doing for the Millwork part of Building Construction.

Guaranteed lists on any construction are supplied at a reasonable charge to interested parties whether Architects, Owners or Contractors.

We invite the co-operation of the Architects that we may be supplied with plans and specifications from which to prepare these lists of quantities; and these in turn will, *at Architect's option*, be priced by the majority of the mills of the city and the attention of the particular plants prepared to handle the work involved, will be drawn thereto by us.

With your co-operation the time lost by Contractors soliciting bids from the various mills will be saved.

This method is not a novelty, it has been tried out in practical use here for a couple of years, and has proven its adaptability to existing conditions and has resulted in an economic gain to its adherents in expense elimination.

Correspondence solicited and investigation of operation and responsibility is courted.

PLANING MILL LISTING BUREAU

Room 234
Builders' Exchange Bldg.,

SAN FRANCISCO



FAIR OAKS SCHOOL, STOCKTON, CALIFORNIA

WRIGHT & SATERLEE, Architects

SHEPHERD & RILEY, Contractors

Michigan Maple Flooring laid in this building, is admitted to be the last word in flooring perfection.

“WOLVERINE Brand,” a Michigan product, has stood the test for years and is an ideal flooring for school buildings.



STRABLE HARDWOOD COMPANY

Formerly
STRABLE MANUFACTURING CO.

Hardwood Lumber — Hardwood Flooring

511-515 First Street
OAKLAND, CALIFORNIA

Engineer Is Optimistic

Mr. Charles T. Phillips, Consulting Engineer, San Francisco, is optimistic over the outlook for building in Central California for this year. He states that he has never had so much work in his office in connection with buildings and new work is coming in every day.

Mr. Phillips says that there has been quite a substantial reduction in electric wiring and steam heating material costs and recent estimates submitted by contractors in these lines should allay any fear among investors that the building situation is not returning to a sane basis.

Hollister Grammar School

Mr. William H. Weeks, 75 Post street, San Francisco, has awarded the contract to Robert Trost for approximately \$80,000 to build a one-story brick grammar school building at Hollister, San Benito county.

Direct Flush Valve of Solid Brass Construction

The Standard Metals Manufacturing Company of Los Angeles has recently erected and equipped an up-to-date factory containing 5,000 square feet of floor space for the manufacture of the Schroeder direct flush valve, used for lavatory toilets and urinals.

The manufacturers claim this to be the only flush valve on the market of solid brass construction, ground valve seat, and opened and closed by water pressure. They state that the valve has been giving excellent service and satisfaction for over seven years in numerous buildings in Los



The Highest Praise

Hundreds of architects specify Bay State Brick and Cement Coating. There is no finer recommendation for this product. It sinks into the surface and literally becomes a part of the wall it covers. It waterproofs all buildings of brick, cement or stucco. Broiling sun or heavy snows do not affect it. Dampness will not seep in. Driving rains cannot beat through it.

Write for samples in white and colors and booklet No. 43. Your request on a postal will bring you both.

WADSWORTH, HOWLAND & CO., Inc.

Paint and Varnish Makers

JAMES HAMBLY & SON
San Francisco Los Angeles



BAY STATE Brick and Cement Coating

Angeles, where they were installed for the purpose of testing them out thoroughly before placing them on the market.

The company has plans completed for an extensive national selling campaign. They are issuing a very attractive booklet to all dealers interested in this new article. The capacity weekly production of the new plant will be several hundred valves.



Hauser Reversible Windows

Used in this Modern School Building.

JOHN Reid, Jr., Architect

HAUSER WINDOW COMPANY

OFFICE AND FACTORY

157 Minna Street, San Francisco. Phone Kearny 3706



The
ST. FRANCIS
One of the world's great hotels
Facing Union Square
SAN FRANCISCO CALIFORNIA

EXPRESSES MOST PLEASANTLY THE HOSPITALITY AND ANIMATION THAT ARE CHARACTERISTIC OF SAN FRANCISCO

Thos. J. Coleman
Manager

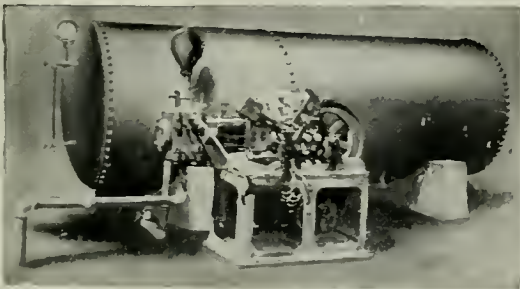

Kewanee Water System

Maintain your own Plant.
Small Operating Expense.
A Perfect Water Supply to
Country Homes, Hotels
and Parks.

Simonds Machinery Co.

117-121 Montgomery Street
SAN FRANCISCO
Phone Kearny 1457

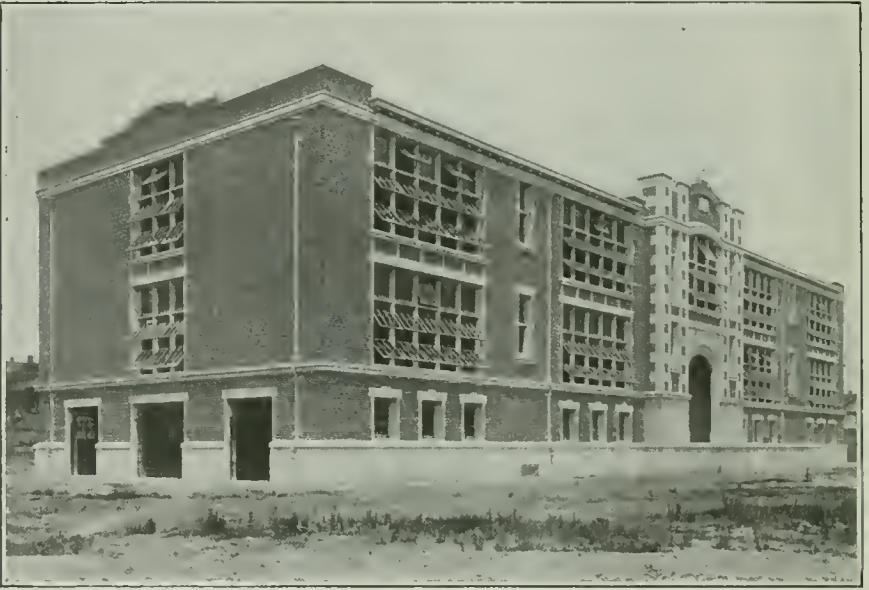

LAKEVIEW SCHOOL, OAKLAND
 J. J. DONOVAN, Supervising Architect SIDNEY B. NEWSOM, Associate Architect
 MEALY & COLLINS, Masonry Contractors

Exterior of

RED RUFFLED FACE BRICK

Manufactured by

Richmond Pressed Brick Co.

(LOS ANGELES PRESSED BRICK CO)



Sold Through

UNITED MATERIALS COMPANY

SHARON BUILDING, SAN FRANCISCO

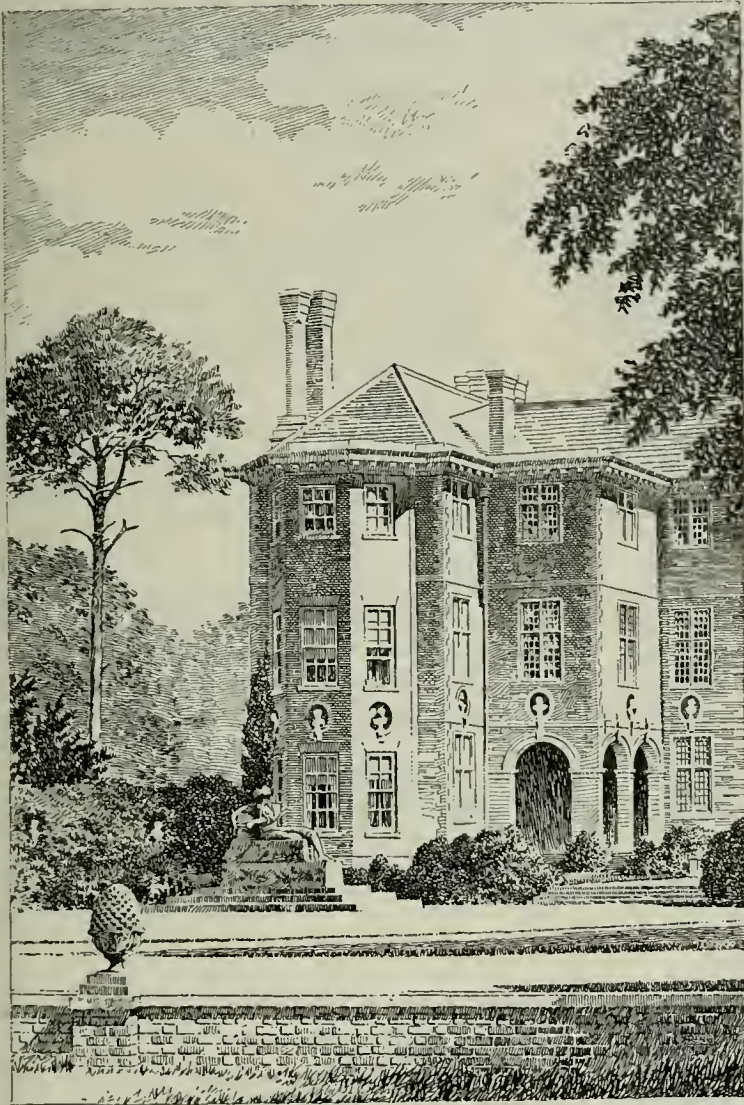

A. F. B. A.
USE FACE BRICK
— it Pays

Ham House,
Petersham, England,
Built in 1610.

THE test of time has thoroughly established the structural strength and enduring beauty of the face brick building. Notable examples of the various architectural periods stand to attest its durability and artistic charm, as well as its adaptability to every kind of structure from the simple cottage to the monumental public building.

Face brick is old, yet ever new. Through the ages it has kept pace with building require-

ments; and still has not yet reached the limits of its artistic possibilities. Each year sees new color tones and textures. Each year sees the development of the genius with which the architect employs this wonderfully old, yet wonderfully new, material.

Any member of this association is at all times ready to discuss the architect's face brick problems with him; and to co-operate with him to the fullest extent.

AMERICAN FACE BRICK ASSOCIATION

1159 WESTMINSTER BUILDING CHICAGO, ILLINOIS

Reprints of this series of drawings by Mr. Jonathan Ring, suitable for filing or framing, will be sent to any architect on request

Use SCHROEDER Direct-Flush Valves

The only All Brass Flush Valve for Toilets on the Market

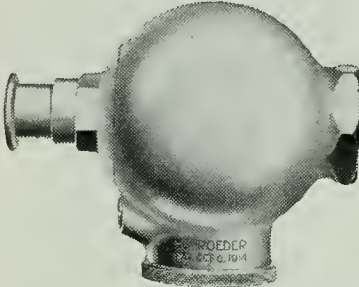

MADE IN FOUR SIZES
 1/2 in. 3/4 in. 1 in. 1 1/4 in.

Unexcelled Simplicity of Construction

- | | |
|-------------------------|--|
| Eliminates Repair Bills | No By-Passes |
| Eliminates Water Waste | No Rubber or Leather Parts |
| Eliminates Corrosion | No Complicated Parts to get out of order |
| Eliminates Hammer | |

Easily and quickly installed

Unequaled for Efficiency and Economy

Write for descriptive booklet

The New Stock Exchange Building (Morgan, Walls & Morgan, Architects) on Spring Street, between 6th and 7th Streets, Los Angeles (a 13-story office building of the very latest type) is equipped throughout with Schroeder Valves. We have many other installations that have stood the test of time and hard usage.

MADE BY

STANDARD METALS MANUFACTURING CO.

1300-1302 N. Main St.

Phone 66864

Los Angeles, Calif.

WaterSavvR FLUSHING VALVE

Non-Clogging, Self-Cleaning, Controlling By-Pass

NOTE

Controlling water is in two enclosed chambers and separated from the flushing water.

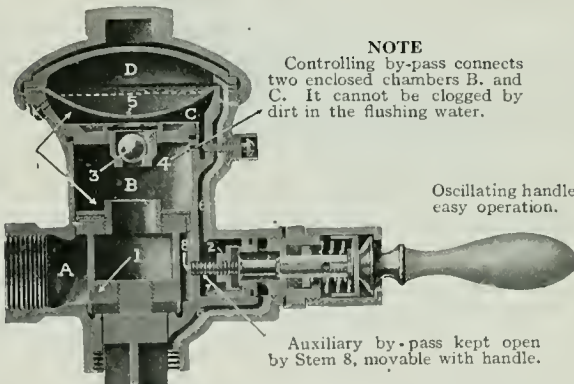

NOTE

Controlling by-pass connects two enclosed chambers B. and C. It cannot be clogged by dirt in the flushing water.

Oscillating handle easy operation.

Auxiliary by-pass kept open by Stem 8, movable with handle.

**OPERATES
 EQUALLY AS
 WELL WITH
 DIRTY
 AS WITH
 CLEAN WATER**

The by-pass is positively and automatically kept open and free of obstruction and cannot become clogged no matter how dirty the water may be.

Patented March 18, 1919

NATIONAL VALVE COMPANY

Phone Douglas 5093

23-25 MINNA STREET, SAN FRANCISCO

The Heart *of the* Kitchen

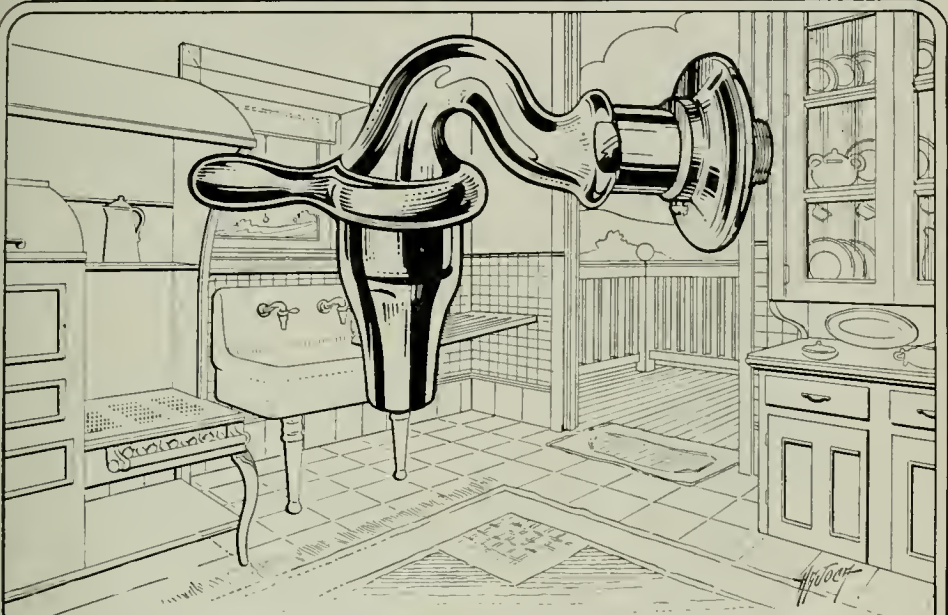

ONE of the most prominent Architect firms in San Francisco, and well known throughout the country, without solicitation on our part, wrote us as follows:

"We not only specify but insist on the plumber furnishing HAJOCA 'Quick' Faucets for all sinks in buildings constructed by us.

We consider everything from the rapid flowing stream to the simplicity of re-washing a delight to the user."

HAJOCA "Quick" Faucets are used not only on kitchen sinks, but shop sinks, laundry trays and factory wash sinks.

Many Architects, like the firm above quoted are standardizing their specifications on HAJOCA "Quick" Faucets.



HAINES, JONES & CADBURY Co.

MAKERS OF PLUMBING SUPPLIES

851-9 FOLSOM STREET, SAN FRANCISCO

PHILADELPHIA-NEW YORK-RICHMOND, VA.-SAVANNAH



**IRON AND STEEL
PRODUCTS**

WAREHOUSE AND
MILL SHIPMENTS

STEEL BARS
for
CONCRETE
REINFORCING
FURNISHED AND
INSTALLED

EDW. L. SOULE' CO.
SAN FRANCISCO



SUTTER
2821

RIALTO
BUILDING



SERVICE
TESTING
INSPECTION
CONSULTATION
PRODUCTION

Structural and Engineering
Materials



Robert W. Hunt & Co.
Engineers

Chemical and Physical
Testing Laboratories

New York Chicago Pittsburgh
St. Louis San Francisco Mexico City
London Montreal

A PROPRIETOR BOUND HIMSELF

to maintain fire insurance for the amount paid by him to the contractor as the construction of the building progressed. The building was burned while in course of construction and the company denied liability on the ground that the proprietor had no insurable interest. The court held that the proprietor had an insurable interest in the building equal to the amount paid to the contractor.

DIXWELL DAVENPORT
Manager Pacific Coast Department

**BANKERS & SHIPPERS
INSURANCE COMPANY**
INSURANCE EXCHANGE BLDG.
SAN FRANCISCO
Telephone Kearny 3561

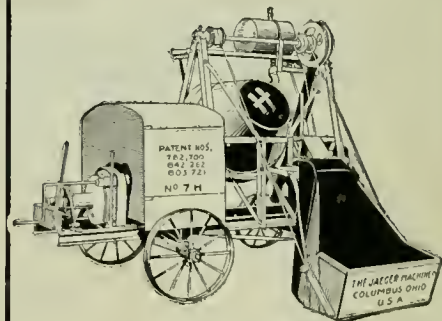

NOT ONLY MIXERS

but a full line of nationally-known equipment, as well.

We have prepared for a brisk building season.

"Get it from BACON"

Edward R. Bacon Company
51 Minna St., San Francisco
165 E. Jefferson St.
Los Angeles

Present Cost of Building Materials* With Labor Wage Scale, Bonds, Etc.

THESE quotations are based on reliable information furnished by San Francisco material houses. Date of quotations, March 15, 1921.

All prices f. o. b. cars San Francisco or Oakland. For country work add freight and cartage to prices given.

American Institute of Architects' Fees

New work—6 per cent minimum basis.
Alterations—7 to 10 per cent as a minimum basis.

High class residence work—10 per cent as a minimum.

Bond—1½% amount of contract.

Brickwork—

Common, \$40.00 per 1000 laid.
Face, \$96.00 per 1000 laid.
Common, f. o. b. cars, \$18.00 plus cartage.
Face, f. o. b. cars, \$60.00 per 1000, carload lots.

HOLLOW TILE FIREPROOFING

12x12x3 in., 10¼c. per square foot.
12x12x4 in., 11¾c. per square foot.
12x12x6 in., 16¼c. per square foot.
Hod carriers, \$8.00 per day.
Bricklayers, \$10.00 per day.
Lime—\$3.25 per bbl.; carload, \$2.75 per bbl.

Composition Floors—30c. per sq. ft.

Concrete Work (material at San Francisco bunkers)—

No. 3 rock.....\$2.50 per yd.
No. 4 rock..... 2.75 per yd.
Niles pea gravel..... 3.25 per yd.
Niles gravel..... 2.50 per yd.
Niles top gravel..... 3.09 per yd.
City gravel..... 2.50 per yd.
River sand..... 1.65 per yd.
Bank sand..... 1.00 per yd.

SAND

Del Monte, \$1.25 to \$1.50 per ton.
Fan Shell Beach, \$2.50 to \$3.00 per ton.
Car lots, f. o. b. Lake Majella.
Cement (f. o. b. cars).....\$3.69 per bbl.
Rebate for sacks, 15c each.
Atlas "White".....\$12.60 per bbl.
Medusa cement.....\$12.60 per bbl.
Forms.....\$30.00 per M
Wage—
Laborers.....\$6.50 per day
Concrete workers..... 7.50 per day
Cement finishers..... 9.00 per day

Dampproofing—

Two-coat work, 25c per yard.
Membrane waterproofing—4 layers of P. B. saturated felt, \$6.00 per square.
Hot coating work, \$2.00 per square.
WAGE—Roofers, \$9.00 per day.

Electric Wiring—\$8.00 to \$12.00 per outlet (including switches).

WAGE—Electricians, \$9.00 per day. For conduit work, knob and tube average \$4.50 outlet.

Elevators—

Prices vary according to capacity speed and type. Consult elevator companies.

Excavation—

\$2.00 per yard.
Teams, \$12.00 per day.
Trucks, \$30.00 to \$40.00 per day.
Above figures are an average without water. Steam shovel work in large quantities, less; hard material, such as rock, will run considerably more.

Fire Escapes—

Ten-foot balcony, with stairs, \$100.00 per balcony.

Glass—(Consult with manufacturers.)

21 ounce, 20c per square foot.
Plate, \$1.75 per square foot.
Art, \$1.00 up per square foot.
Wire (for skylights), 45c. per square foot.
Obscure glass, 30c. per square foot.
Note.—Add extra for setting.
WAGE—Glaziers, \$9.00 per day.

Heating—

Average, \$2.00 per sq. ft. of radiation, according to conditions.
WAGE—Steamfitters, \$10.00 per day.

Iron—

Cost of ornamental iron, cast iron, etc., depends on design.

Lumber—(Prices delivered to bldg. site)

Common (at bldg.), \$34 per M (average)
Com'n O. P. (select), \$45 per M (average)

Flooring—

1x3 No. 1.....\$75.00 per 1000
1x3 No. 2..... 70.00 per 1000
1x4 No. 1..... 75.00 per 1000
1x4 No. 2..... 70.00 per 1000
1x4 No. 3..... 60.00 per 1000
1x6 No. 1..... 75.00 per 1000
1x6 No. 2..... 70.00 per 1000
1¼x4 and 6 No. 1..... 78.00 per 1000
1¼x4 and 6 No. 2..... 73.00 per 1000
Slash grain, 1x4 No. 2..... 60.00 per 1000
Slash grain, 1x4 No. 3..... 55.00 per 1000
No. 1 common run to
T. & G. 35.00 per 1000
Lath 6.00 per 1000

Shingles—(Add cartage to prices quoted)

Redwood, No. 1.....\$1.00 per bdle.
No. 2..... .90 per bdle.
Red Cedar 1.10 per bdle.

Hardwood Floors—

Maple floor (laid and finished), 30c per foot.
Factory grade floors (laid and finished), 23c per foot.
Oak (quartered, finished), 40c per foot.
¾ Oak (clear), 30c per foot (plain).
¾ Oak (select), 28c per foot (plain).
¾ Oak, quartered, sawed, clear, 35c.
WAGE—Floor layers, \$10.00 per day.

Hardwood Floors (not laid)— Per M ft.

5/16x2" sq. edge Clear quartered oak.....\$220.00
Select quartered oak..... 162.50
Clear plain oak..... 147.50
Select plain oak..... 127.50

THE ARCHITECT AND ENGINEER

Hardwood Floors (not laid)—Continued

		Per M ft.
13/16x2 1/4" face	Clear quartered oak.....	\$292.50
	Select quartered oak.....	200.00
	Clear plain oak.....	200.00
	Select plain oak.....	180.00
	Clear maple.....	160.00
	Clear maple—white.....	250.00
13/16x3 1/4" face	Clear maple.....	160.00
1 1/8x2 1/4" face	Clear maple.....	160.00
3/8x2" face	Clear quartered oak.....	215.00
	Select quartered oak.....	160.00
	Clear plain oak.....	147.50
	Select plain oak.....	127.50
	Clear maple.....	122.50

Millwork—

O. P., \$100 per 1000. R. W., \$140 per 1000	
Double hung box frame windows (average) with trim.....	\$7.50 each
Doors, includ. trim (single panel).....	\$11.00 each
Doors, including trim (five panel).....	\$9.00 each
Screen doors.....	3.00 each
Window screens.....	2.25 each
Medicine cases.....	4.00 each
Cases for kitchen pantries seven feet high, per lineal foot.....	7.50 each
Dining room cases same price, if not too elaborate....	7.50 each
Flag poles, per foot.....	1.00
Labor—Rough carpentry, warehouse heavy framing, \$13.00 per 1000.	
For smaller work, average, \$21.00 to \$28.00 per 1000.	
WAGE—Laborers, \$6.50 per day.	
Carpenters, \$9.00 per day.	

Marble—(Not set) add 60c up per ft. for setting	
Columbia.....	\$2.05 sq. ft.
Alaska.....	2.05 sq. ft.
San Saba.....	3.65 sq. ft.
Tennessee.....	2.50 sq. ft.
Verde Antique.....	4.55 sq. ft.

Painting—

Two-coat work, 42c. per yard.	
Three-coat work, 55c per yard.	
Whitewashing, 5c per yard.	
Cold water paint, 9c per yard.	
Turpentine, \$1.07 per gal. in cases and 92c per gal in tanks.	
Raw Linseed oil, 94c per gal in barrels.	
Boiled Linseed oil, 96c per gal in bbls.	
Pioneer white and red lead, 1 1/4c lb. in one ton purchases; 1 1/2c lb. for less than 500 lbs.	
WAGE—Painters, \$8.50 per day.	

NOTE—Accessibility and conditions cause wide variance of costs.

Patent Chimneys—

6-inch.....	\$1.50 lineal foot
8-inch.....	1.75 lineal foot
10-inch.....	2.25 lineal foot
12-inch.....	3.00 lineal foot

Pipe Casings—\$8.00 each.

Plastering—

Interior, on wood lath, 75c per yard.	
Interior, on metal lath, \$1.40 per yard.	
Exterior, on brick or concrete, \$1.35 per yard.	
Portland White, \$1.75 to \$2.00.	
Interior on brick or terra cotta, 60c to 70c per yard.	
Exterior, on metal lath, \$2.00 to \$2.50 per yard.	
Wood lath, \$6.50 at yard per 1000.	

Metal studding, with lath and plaster, \$2.00 per yard.

Galv. (metal lath), 38c. and up per yard, according to gauge.

Lime, f. o. b. warehouse, \$3.25 per bbl. Hardwall plaster, \$22.00 per ton, f. o. b. warehouse. (Rebate on sacks, 15c.)

WAGE—Hod carriers \$9.00 per day. Plasterers, \$11.00 per day.

Plumbing—

From \$70.00 per fixture up, according to grade, quantity and runs.

WAGE—Plumbers, \$10.00 per day.

Reinforcing Steel—

Base price for less than car load lots, \$4.25 per 100 lbs.

Carload lots, \$4.00 per 100 lbs., f. o. b. San Francisco. (Mill delivery.)

Roofing—

Five-ply tar and gravel, \$7.00 per square for 30 squares or over.

Less than 30 squares, \$8.00 per square.

Tile, \$35.00 to \$50.00 per square.

Redwood shingle, \$10.00 per sq. in place.

Cedar shingle, \$10.00 per square in place.

Reinforced Pabco roofing, \$8.25 per square. WAGE—Roofers, \$9.00 per day.

Rough Hardware—

Nails, per keg, \$7.00 base and very scarce. Deafening felt, \$170.00 per ton.

Building paper, P. & B.,

1 ply, \$5.10 per 1000 ft. roll.

2 ply, \$7.50 per 1000 ft. roll.

3 ply, \$10.00 per 1000 ft. roll.

Sash cord,

(Sampson spot), \$3.00 per hank 100 ft.

Common, \$1.75 per hank 100 feet.

Sash weights, cast iron, \$70.00 per ton.

Sheet Metal—

Windows—Metal, \$2.00 a square foot.

Skylights—

Copper, \$1.25 a square foot (not glazed).

Galvanized iron, 40c a square foot (not glazed).

WAGE—Sheet metal workers, \$10.00 per day.

Store Fronts—

Kawneer copper bars for store fronts. Corner, center and around sides, will average \$1.35 per lin. foot.

Zouri bar, \$1.25 per lin. foot.

Zouri Underwriters' Specification sash, \$1.60 per lin. foot.

Structural Steel—\$140.00 per ton (erected).

This quotation is an average for comparatively small quantities.

Light truss work higher; plain beam and column work in large quantities, less.

Steel Sash—

Fenestra, from S. F. stock, 45c. per sq. ft.

Fenestra, Plant shipment, 40 1/2c. per sq. ft. (Includes mullions and hardware.)

Trus-con, from San Francisco stock, 40c to 45c per sq. ft.

Trus-con, plant shipment, 35c to 42c per sq. ft.

U. S. Metal Products Co., 40c per sq. ft. in San Francisco.

Tile—

White glazed, 80c. per foot.

White floor, 80c. per foot.

Colored floor tile, \$1.00 per foot.

Promenade tile, \$1.00 per sq. foot, laid.

WILSON FOLDING PARTITIONS

For **SCHOOLS, Clubs, Churches, Hotels, Y. M. C. A. Buildings, or any building where a division of space is required.** *Easy to Operate — Not Accordion — No Hangers.*



Partition Folded in Pocket

Illustration of Wilson Folding Partition as installed in Harrison Street School, San Francisco; Architect, John Reid, Jr., San Francisco.

Note.—This partition is equipped with Wilson automatic folding chalk rails and spring jambs, allowing for expansion or contraction of doors. Wilson Folding Partitions are standard in most all large cities for their schools.



Partition Drawn Out

Manufactured by

THE J. G. WILSON CORPORATION

PACIFIC COAST OFFICE AND EXHIBIT

600 Metropolitan Building, Phones 60871; Bdy. 502, Los Angeles, Calif.

Also Manufacturers of DIFFUSELITE BLINDS AND AWNINGS, ROLLING PARTITIONS, ROLLING STEEL DOORS, SCHOOL WARDROBES

Waterhouse-Wilcox Co., San Francisco; Theo. F. Snyder, San Diego; F. W. Farrington & Co., Portland; S. W. R. Dally, Seattle; T. G. Bush & Co., Spokane; Hawley-Richardson-Williams Co., Salt Lake City; Walter Dubree, Phoenix.

FORDERER CORNICE WORKS

ANNOUNCES THE COMPLETE INSTALLATION OF EQUIPMENT NECESSARY FOR THE MANUFACTURE OF HOLLOW METAL DOORS AND TRIM; ALSO FILING CABINETS AND LOCKERS WITH BAKED ENAMEL FINISH.

THIS EQUIPMENT IS OF THE VERY LATEST AND IMPROVED TYPE, ENABLING THEM TO PRODUCE WORK EQUAL, IF NOT SUPERIOR, TO THAT OF ANY EASTERN MANUFACTURER.

WHEN INTERESTED, COMPLETE DETAILED INFORMATION AND SAMPLES SHOWING CONSTRUCTION AND FINISH WILL BE CHEERFULLY FURNISHED.

FORDERER CORNICE WORKS**SIXTEENTH AND POTRERO****SAN FRANCISCO**

Feeding the Brute to Discover Its Habits



THIS picture shows the testing-yards where we continually feed metal to the great iron-eater—rust.

Snow and rain, cold and heat—all the elements are given a chance to show their power of destruction on sheets of "Armco" Ingot Iron and other metals.

When the metal sheets have been there for months, the chemists and metallurgists examine sections under a powerful microscope. To an outsider, the difference in effect on "Armco" Ingot Iron and other irons would be a revelation.

The survival of "Armco" Ingot Iron is due to its purity. Foreign matter that invites rust has been eliminated during the special process of manufacture.

These testing-yards and our extensive research laboratories are indications of the great, unceasing care taken to maintain the purity of "Armco" Ingot Iron. If you are a manufacturer or user of iron products where rust-resistance is required, write to us.

Snow-covered Testing Yards at Armco Plant



The trade-mark ARMCO carries the assurance that products bearing that mark are manufactured by the American Rolling Mill Company with the skill, intelligence, and fidelity associated with its products, and hence can be depended upon to possess in the highest degree the merit claimed for them. The trade-mark ARMCO is registered in the U. S. Patent Office.

THE AMERICAN ROLLING MILL CO.

MIDDLETOWN, OHIO

An Ample Stock of ARMCO Iron is Carried at San Francisco Warehouse, Tenth and Bryant Streets.

Insulex

This new heat insulation not only excels in durability and efficiency as a steam pipe covering but is especially adaptable to refrigeration practice.

AMERICAN INSULEX COMPANY
204 BERKELEY BANK BUILDING, BERKELEY Phone Berkeley 641

CHAS. STOCKHOLM & SONS GENERAL CONTRACTORS

849 MONADNOCK BUILDING Phone DOUGLAS 4657 SAN FRANCISCO

John Ringius Company, Inc.

MANUFACTURERS OF

Multivane Volume Fans and Steel Plate Blowers made to order, any size, for Heating and Ventilating Plants in Theatres, Schools, Public Buildings, Etc.

Sheet Metal Products

Fans and Blowers

1267 Folsom Street

SAN FRANCISCO

Phone Garfield 1108

JOHN M. BARTLETT

GENERAL CONTRACTOR

Office
357 - 12th ST., OAKLAND

Phone Lakeside 6750
Res. Phone Berkeley 6884W

E. T. LEITER & SONS

BUILDING CONSTRUCTION

412 CALL-POST BUILDING

Phone SUTTER 1980

SAN FRANCISCO

Shop and Compare—that's the only true test of values.

Furnishings for the home of distinctive style are featured in this shop at prices that will bear the strictest comparison.

Furniture Draperies Floor Coverings Interior Decorations

John Breuner & Co.
of San Francisco

281 GEARY STREET

SAMSON SPOT SASH CORD

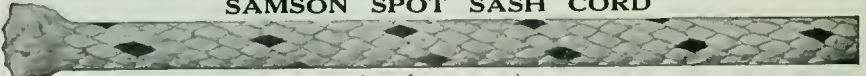

SPOT IT BY THE SPOTS

Made of extra quality cotton yarn, firmly braided and smoothly finished. Carefully inspected and guaranteed free from all imperfections of braid and finish. → Can be distinguished at a glance by our trade-mark, the Colored Spots. Send for catalogue and samples.

Pacific Coast Agent, JOHN T. ROWNTREE, Inc., San Francisco and Los Angeles, Cal.

A TEN YEAR GUARANTEE

is back of this roof covering and it **costs less** than other roofing materials



2400 gallons used on the Fairmont Hotel, San Francisco.

Bekin's Warehouse is waterproofed with it.

The W. O. W. Building, Oakland, is roofed with it.

You make no mistake when you specify

LIQUID ASBESTOS PATCH-HOLE CEMENT

Write for sample and price list.

California Plastic Products Company

521 SHELDON BUILDING, SAN FRANCISCO, CALIFORNIA

When writing to Advertisers please mention this magazine.

Look for this
Trademark



And if it's there don't worry any more about your Valves and Fittings



Specify and insist upon having

**The Kelly & Jones Co.
Valves and Fittings**

**Byers Genuine
Wrought Iron Pipe**

Republic Steel Pipe

Complete Line of Plumbing Supplies
Large Stocks for Prompt Delivery
Catalogue on request

California Steam & Plumbing Supply Co.

671-679 Fifth Street, Corner Bluxome
SAN FRANCISCO, CALIFORNIA

When writing to Advertisers please mention this magazine.

**FOR MODERN
STORE FRONTS**

Plummer's Disappearing Awnings

Are constructed with no outside attachments below awning recess. All mechanical parts entirely concealed. Send for Architects' Sheet showing specifications for recess construction, etc.

W. A. PLUMMER MFG. CO., 35-37 Front Street, San Francisco

JOHN TRAYNOR

CHARLES HARCOURT

OCEAN SHORE IRON WORKS

Manufacturers of Oil Tanks, Water Tanks, Pressure Tanks, Air Receivers, Feed Water Heaters, Breechings, Smoke Stacks, Water Pipe, Boilers, Retorts, Digestors, Pneumatic Pressure Tanks, Riveted or Oxy-Acetylene Welded Tanks, and dealers in Boilers, Tanks, Pumps, Engines, Machinery, Steel Plates, Shapes

Special Attention Given to Government and Export Orders

OCEAN SHORE IRON WORKS

Office and Works: 550-558 EIGHTH STREET,

SAN FRANCISCO, CAL.

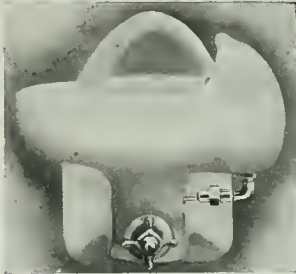

Model No. 7A.

NO GERMS HERE

HAWS IMPROVED SANITARY DRINKING FAUCET eliminates all possibility of contracting disease from dirty bulbs or unsanitary bowls. Provided with an overhead cowl, the drinker's lips never touch the source of supply. A slanting stream throws the water from right to left and away from the bubbler, instead of straight up to fall back over the fountain head. Recommended for Schools and Public Playgrounds. A type used extensively by the U. S. Government. Manufactured by

Haws Sanitary Drinking Faucet Co., Inc.
1808 Harmon Street, Berkeley Phone Piedmont 3742

GLADDING, McBEAN & CO.

MANUFACTURERS CLAY PRODUCTS
CROCKER BUILDING, SAN FRANCISCO
WORKS. LINCOLN, CAL.

SONNEBORN PRODUCTS

Grind-Proof *and* Dust-Free Concrete Floors!

DUSTING WEARING CONCRETE FLOORS
ARE A THING OF THE PAST WHEREVER
ARCHITECTS HAVE SPECIFIED

Lapidolith

THIS liquid chemical has been flushed on 70,000,000 square feet of concrete floors old and new during the last two years alone. These lapidolized floors are now wearproof and dust-proof, because Lapidolith has completed the hydration of the Portland Cement and this Concrete is harder than granite.

Have you seen the results secured by the Lapidolith treatment? If not, let us refer you to a lapidolized floor near you. Thereafter you will specify Lapidolith on your old and new concrete work.

SONNEBORN PRODUCTS:

Cemcoat

the durable Mill White, Washable, of exceptional covering capacity, Gloss, Flat and Egg-shell, also all colors.

Lignophol

the modern wood preservative gives new life to old or new wooden floors.

Write for sample, literature and specification form

*Concrete for Permanence
Lapidolith for Dustlessness*

L. SONNEBORN SONS, Inc.

San Francisco

Los Angeles

Seattle

SONNEBORN

THE TORMEY CO.

Phone Franklin
5-5-9-8

1042 Larkin St., San Francisco, Cal.

Alvaline, Cementoline

and other

Jones-Duncan Products

**MAGNER BROTHERS
PAINT MAKERS**

Telephone: Market 113
414-424 Ninth St. San Francisco

HEATING=PLUMBING

COMPLETE PLUMBING AND
HEATING SYSTEMS INSTALLED
IN ALL CLASSES OF BUILDINGS
ALSO POWER PLANTS

GILLEY-SCHMID CO., Inc.

198 OTIS STREET, SAN FRANCISCO.
Tel. MARKET 965

“BLAZING” THE TRAIL

We've been doing it for many years—giving the Sportsman Better Value for Quality than he ever before received. “Value at a Fair Price” in everything for the Sportsman.



SEND FOR CATALOG *The Sign of Quality*

Phone Douglas 3224

**Hunter & Hudson
ENGINEERS**

Designers of Heating, Ventilating
and Wiring Systems. Mechanical
and Electrical Equipment of
Buildings.

703 Rialto Bldg., San Francisco, Cal.

**BEAVER BLACKBOARD
BEAVER GREENBOARD**

SCHOOL FURNITURE
AND SUPPLIES—
OFFICE, BANK AND
COURTHOUSE FURNITURE—
THEATRE AND
AUDITORIUM SEATING

Rucker-Fuller Desk Co.

677 Mission St., SAN FRANCISCO, CAL.
434 Higgins Bldg., LOS ANGELES, CAL.
432 - 14th Street - OAKLAND, CAL.

NATIONAL ROOFING COMPANY
J. F. ELLIS
PACIFIC ROOFING COMPANY
J. B. McKEON
C. G. WILLIAMS
A. K. GOODMUNDSON

Members of
Builders and Roofers Exchange
2140 San Pablo Avenue, OAKLAND
Lakeside 271

RUSSWIN

BUILDERS' HARDWARE

JOOST BROS., Inc.

SAN FRANCISCO AGENTS.

We Carry Complete Stock:

Fishing Tackle—Guns—Mechanics' Tools—
Paints—Crockery and Glassware—Stoves—
Household Goods. Telephone Market 891.

NO BRANCH STORE

Mazda Lamps Electric Goods

Your Client, Mr. Architect Demands

Snow White Brilliance

Upon a Smooth Surface

☐ Petrium Sanitary Sinks answer every requirement. They are non-porous, non-absorbent and lye-proof. There are no crevices or corners to catch the dirt and grease. ☐ Therefore Specify this sink.

☐ Can be installed in any home or apartment — new or old. A California product.

Send for our Booklet and Price List

**Petrium Sanitary Sink
Company**

Factory and Office, West Berkeley



PORTAL Economy Plan Service and PORTAL Quality Wall Beds

PORTAL wall-beds have received Highest Award wherever exhibited—an evidence of quality that should interest the Builder.

Patented oscillating arm permits the "Portal" bed to revolve in a foot less space than any other revolving bed—a good point to remember.

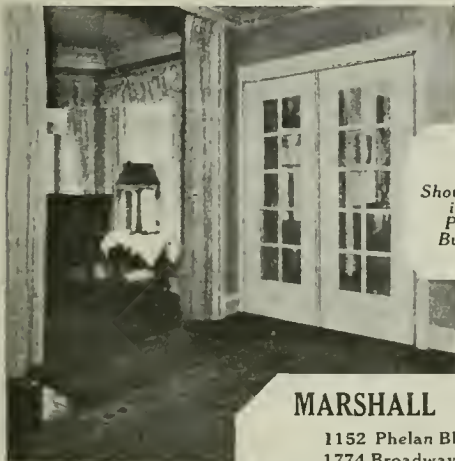

See
Show Rooms
in the
Phelan
Building

MARSHALL & STEARNS CO.

1152 Phelan Bldg., San Francisco
1774 Broadway, Oakland

When writing to Advertisers please mention this magazine.

A. D. COLLMAN

P. F. SPEIDEL

COLLMAN AND SPEIDEL**GENERAL
CONTRACTING****CONSTRUCTION
ENGINEERS**

Telephone SUTTER 4858

MONADNOCK BUILDING, SAN FRANCISCO

I. R. KISSEL

Phone Franklin 548

Decorator, Painter and Paperhanger

1747 SACRAMENTO ST., Bet. Polk St. and Van Ness Ave., SAN FRANCISCO

ROBERT TROST

PHONE MISSION 2209

General Building ContractorWe Specialize in High Grade Work and Employ Skilled
Labor in every Branch of the Building Industry.26th and Howard Streets
SAN FRANCISCO

P. A. Palmer

Peter Petersen

W. L. Kelly

PALMER & PETERSEN**Contracting Engineers**

782-796 Monadnock Building

SAN FRANCISCO, CAL.

S. RASORI, RES. 2042 TAYLOR ST.
PHONE FRANKLIN 6258J. DEL FAVERO, RES. 1839 MASON ST.
PHONE FRANKLIN 9524**DEL FAVERO & RASORI**
GENERAL CONTRACTORS

MEMBERS OF THE S. F. BUILDERS EXCHANGE AND THE BUILDING INDUSTRIES ASS'N

OFFICE:
110 JESSIE STREET

SAN FRANCISCO, CALIF.

MONSON BROS.**GENERAL CONTRACTORS**

Telephone Market 2693

1908 Bryant Street, San Francisco

UNIT CONSTRUCTION COMPANY

(INCORPORATED)

ENGINEERING AND CONSTRUCTION

Telephone Kearny 28

429-36 Phelan Building, SAN FRANCISCO

J. D. HANNAH**Contractor and Builder**OFFICE: 142 Sansome Street
San Francisco, Cal.Telephone Douglas 3895
BUILDERS EXCHANGE, 180 JESSIE STREET

MOUNT DIABLO CEMENT
COWELL SANTA CRUZ LIME

ALL KINDS OF

BUILDING MATERIALS

HENRY COWELL LIME AND CEMENT CO.

Phone Kearny 2095

No. 2 MARKET STREET, SAN FRANCISCO

Automatic Fire Sprinklers

Protect your building and business from destruction by fire and reduce your Insurance Rate.

Pacific Fire Extinguisher Co.

FIRE PROTECTION ENGINEERS

424-440 HOWARD STREET
SAN FRANCISCO

MANUFACTURING PLANT
272 STEUART STREET

LINOTILE

“The Floor that’s Built to Fit the Room”

Furnished and Laid by

VAN FLEET-FREEAR CO.

Telephone :
Douglas 1227

61 New Montgomery Street
San Francisco, California

Kawneer

Factory
Berkeley, Calif.
Berkeley 8710

MANUFACTURING COMPANY
of California

San Francisco Office :
180 Jessie Street
Sutter 6700

Kawneer
Store-Fronts
All Metal Mouldings

Kawneer
Simplex Windows
Weightless & Reversible

I. M. SOMMER

CONTRACTOR & ENGINEER

Phone Kearny 4582

401 BALBOA BLDG., SAN FRANCISCO

K. E. PARKER COMPANY, Inc.

GENERAL CONTRACTORS

Phone Sutter 5661

Room 515 Clunie Building, SAN FRANCISCO

R. W. LITTLEFIELD BUILDING CONSTRUCTION

357 12th Street, Room 9, Oakland, Cal.

Phone Lakeside 6750

H. H. HILP, Jr.

J. FRANK BARRETT

BARRETT & HILP

CONCRETE CONSTRUCTION BUILDERS GENERAL CONTRACTORS

SHARON BUILDING, SAN FRANCISCO

TELEPHONE SUTTER 1168 or 1169

Res. Phone Mission 5049

JAMES F. SMITH — Plasterer

273 Minna Street, San Francisco

Phone KEARNY 740

Member Builders Exchange

STEEFORMS Signify ECONOMY, RAPIDITY, and EFFICIENCY

STEEFORM CONTRACTING COMPANY

STEEFORMS FOR
CONCRETE
BUILDINGS

C. B. Hopkins, C. E., Manager
681 Market Street, San Francisco

CONCRETE JOIST
FLOOR
CONSTRUCTION

W. C. DUNCAN & CO.

205 Sharon Bldg.

General Contractors

San Francisco

Telephone Kearny 772

M. E. VUKICEVICH

SPENCER B. BAGGE

VUKICEVICH & BAGGE GENERAL CONTRACTORS

Phone Sutter 6700

Office, Builders Exchange, 180 Jessie St., San Francisco

245 Market St. **Standard Fence Co.** 310 Twelfth St.
 S. F. Kearny 2028 **WIRE AND IRON WORKS** Oakland 475

DESIGNERS - BUILDERS
 WIRE GRILL WORK—WIRE SCREEN
 FACTORY PROTECTION FENCE FLEXIBLE WIRE CONVEYOR BELT
 AVIARY AND TENNIS COURT FENCE WIRE SPECIALTIES

320 North Los Angeles Street, Los Angeles, Cal. Phone 67188

Steel Bars FOR CONCRETE REINFORCEMENT
 Cut to Length, Fabricated, Installed

BADT-FALK & CO.

Tel. Douglas 3466 346 Call-Post Bldg., 74 New Montgomery St., San Francisco

BUILDING DIRECTORIES [INTERCHANGEABLE STEEL]
 LETTERS AND NUMBERS

FOR OFFICE BUILDINGS, SCHOOLS, CAFETERIAS, Etc.
 Bargains Lists for Auto Sales Companies. Sold Outright.

Go-Sign and Letter Manufacturing Co.

1106 Franklin Street Oakland, California

D. N. & E. WALTER & CO.
 "SINCE 1858"

LINOLEUMS—CARPETS LARGE STOCKS CARRIED
 Estimates furnished on request

562-572 MISSION STREET SAN FRANCISCO

Phone Merritt 668

H. N. McNAB

Hardwood Floors  Floor Sanding

2307 - 17th Ave. Oakland, Cal

Res. Tel. Merritt 3600

HERBERT BECKWITH
Building Construction

Formerly with ARTHUR ARLETT 323 Newton Ave.
 Oakland

D. ZELINSKY & SONS
 PAINTERS AND DECORATORS

420 TURK STREET, SAN FRANCISCO

CHARLES T. PHILLIPS
 CONSULTING ENGINEER

PACIFIC BUILDING SAN FRANCISCO
 HEATING VENTILATION WIRING ILLUMINATION

Ideal Air-Washers. Ideal Fruit-Dryers. Fan Systems for Heating, Cooling and Drying.

Ideal Heating and Engineering Co.

Air-Conditioning, Heating, Cooling and Drying

192 ERIE STREET

Phone Market 3708

SAN FRANCISCO

Atlas Heating and Ventilating Co., Inc.

ENGINEERS and CONTRACTORS

STEAM AND HOT WATER HEATING, FANS, BLOWERS,
FURNACES, POWER PLANTS—SHEET METAL WORK

Phone Douglas 378

Fourth and Freelon Sts., Bet. Bryant & Brannan, SAN FRANCISCO

Illinois Automatic Vacuum and Vapor Systems of Heating

"TWENTY-FIVE YEARS OF QUALITY"

ILLINOIS ENGINEERING COMPANY

JAS. I. KRUEGER, *Representative*

559-561 Pacific Building, San Francisco

Telephone: Sutter 7057

HEATING
VENTILATION

FLOOR AND WALL TILING

PLUMBING
SHEET METAL WORK

SCOTT CO., Inc.

SUCCESSOR TO JOHN G. SUTTON CO.

243 MINNA STREET

SAN FRANCISCO

ALEX COLEMAN

CONTRACTING PLUMBER

706 ELLIS ST., SAN FRANCISCO

Phone FRANKLIN 1006

WM. F. WILSON COMPANY

MODERN SANITARY APPLIANCES

Special Systems of Plumbing for Residences, Hotels, Schools, Colleges, Office Buildings, Etc.

Phone Sutter 357

328-330 Mason Street, San Francisco.

C. DRUCKER

J. C. JAMES

JAMES & DRUCKER

Plumbing—Heating Contractors

Phone Market 275

450 Hayes Street, San Francisco, Cal.

The Granite Work on Eldorado County Courthouse; National Bank of D. O. Mills, Sacramento;—
and Sen. Nixon Mausoleum, Reno, WAS FURNISHED BY

CALIFORNIA GRANITE COMPANY

STONE CONTRACTORS

Phone Sutter 2646

Builders' Exchange, San Francisco
Quarries, Rocklin and Porterville

Main Office, Rocklin, Placer Co., Cal.
Telephone Main 82

Bath Room Fixtures

A BATH ROOM should be just as true an expression of the owner's taste and individuality as any other room of the house.

No more is it considered a luxury, but an absolute necessity to your health and comfort.

Our fixtures reflect the finest ideas in design and construction as related to sanitation, utility and service.

To give this subject the attention it demands, you should visit our display rooms at 64 Sutter Street, San Francisco.

Holbrook, Merrill & Stetson

DEALERS IN



Plumbers' Supplies, Iron Pipe and Fittings, Metals, Steam, Water and Hot Air Heating Apparatus, Stoves, Ranges, Kitchen Utensils.

Show Room, 64 SUTTER STREET
Main Office and Warehouse,
Sixth, Townsend and Bluxome Streets, San Francisco

Designers - Fabricators - Erectors

General Plate Work



Hydro - Pneumatic Pressure Tanks —
Hemispherical Bottom Tanks and Towers
— Oil and Water Tanks — Oil Stills —
Pipe Lines—Smoke Stacks—Well Casing
— Rock Screens — "Western" Corru-
gated Culvert Pipe.

Western Pipe and Steel Company

OF CALIFORNIA

444 MARKET STREET
SAN FRANCISCO

1758 NORTH BROADWAY
LOS ANGELES



CEMENT GUN

Will Make Your
Concrete Waterproof

Cement Gun Con-
struction Company
of California

701 Balboa Building,
San Francisco

For
DAMS
RESERVOIRS
TUNNELS
BULKHEADS
CANAL
LININGS
CEMENT
FLUMES
use the
Cement Gun
—
SPEED
ECONOMY
PERMANENCE



LIGHT WEIGHT
FIREPROOF
EVERLASTING

STONE SHINGLES

McCLENAHAN
PRODUCTS
COMPANY

VARIETY
and
DURABILITY
of COLORS

670 Howard St.

INC.

San Francisco

QUEBRACHO!

One coat Argentine Quebracho paint on steel will out-
wear three of red lead and graphite at fraction of cost.
Contains South American gum that gives great tenacity.
Ask about records on steel; also for damp-proofing con-
crete and for protecting piling from teredos.

IMP MANUFACTURING CO.
732 Second St., Oakland Phone Lakeside 478

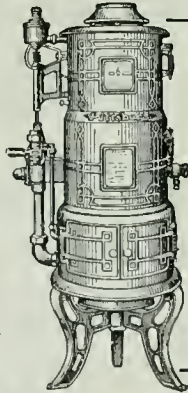

Pittsburg

It Insures
Instant
Hot Water
Service

**PITTSBURG WATER
HEATER COMPANY**
478 Sutter St., San Francisco
Phone Sutter 5025

**BUSINESS • SYSTEMS
OFFICE • FURNITURE**



F. W. Wentworth & Co.
539 MARKET ST., SAN FRANCISCO
DISTRIBUTORS FOR SALES ROOMS IN OAKLAND
LIBRARY BUREAU LOS ANGELES SEATTLE

WIRING



185 Stevenson Street, San Francisco
Phone Douglas 4832

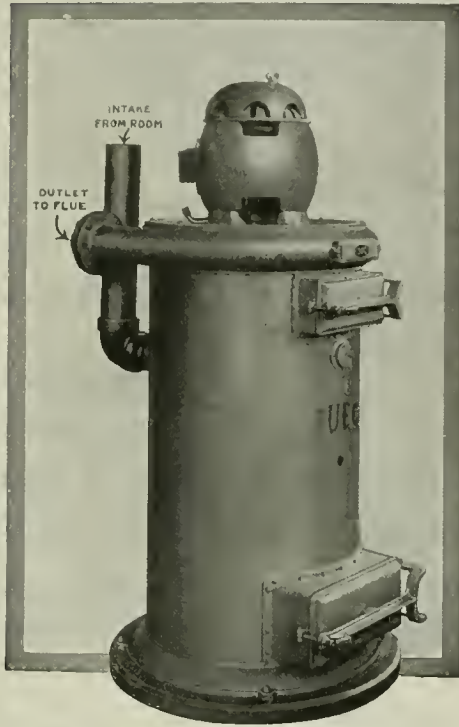

TUEC STATIONARY CLEANER

THE cleaner that reduces building maintenance expense by keeping floors, walls, stairways, merchandise and other stocks, carpets, furniture and furnishings free from dust and dirt. No other cleaning device or dust removal method is so thorough, efficient, and economical. Investigate yourself and invite your client to do so. Write for our free catalog and full information.

THE UNITED ELECTRIC CO.

CANTON, OHIO.

Canadian Plant: Toronto, Ont.

California Distributors

S. F. COMPRESSED AIR CLEANING CO.
397 Sutter Street, San Francisco

BARKER BROS.

724 S. Broadway, Los Angeles

When writing to Advertisers please mention this magazine.



POSITIVE ELECTRIC INTERLOCK

(BAR LOCK TYPE)

Prevents Elevator Accidents Occurring at the Entrance Door

Approved by National Underwriters Laboratories—Meets requirements of Elevator Safety Orders of Industrial Accident Commission, State of California

ELEVATOR SUPPLIES COMPANY, Inc. 186 FIFTH STREET,
SAN FRANCISCO

Capital \$1,000,000

CALIFORNIA DEPARTMENT

Surplus \$1,122,000

THE FIDELITY AND CASUALTY COMPANY OF NEW YORK

Prompt Service for

BONDS AND CASUALTY INSURANCE

203-206 Merchants Exchange Building

SAN FRANCISCO, CAL.

ANY PLACE ANY TIME PROMPTLY "We Serve You"
JOHN H. ROBERTSON

Successor to Robertson & Hall

GENERAL INSURANCE

Phone Sutter 2750

621 First National Bank Building, San Francisco

PACIFIC DEPARTMENT

Globe Indemnity Company

BONDS and CASUALTY INSURANCE for CONTRACTORS

FRANK M. HALL, formerly Robertson & Hall, Mgr.

120 Leldesdorff Street Phone Sutter 2280 SAN FRANCISCO

National Surety Company of New York

The World's Largest Surety Company

Assets over \$20,000,000

Pacific Coast Department: 105 MONTGOMERY ST., SAN FRANCISCO, CAL.

Frank L. Gilbert, Vice-President

Phone, Sutter 2636

School and Theatre

STAGES AND EQUIPMENT

EDWIN H. FLAGG

SCENIC COMPANY, Inc.
400 Pantages Bldg., San Francisco, Cal.
1638 Long Beach Ave., Los Angeles, Cal.

PHONE DOUGLAS 2370

McLERAN & PETERSON

GENERAL CONTRACTORS

HEARST BUILDING

SAN FRANCISCO, CAL.

L. J. RUEGG

J. B. RUEGG

RUEGG BROS.

CONTRACTORS AND BUILDERS

Phone Douglas 1599

719 Pacific Building, SAN FRANCISCO



Steel ^{Open} ^{Hearth} Bars For Concrete Reinforcement

Square, Deformed and Cold Twisted, Plain Rounds and Squares

PACIFIC COAST STEEL COMPANY

General Office, Rialto Building, San Francisco. Phone Sutter 1564

Sales Office, Rialto Building, SAN FRANCISCO
 Sales Office, Union Oil Building, LOS ANGELES
 Sales Office, SEATTLE, WASH.

ROLLING MILLS:
 SOUTH SAN FRANCISCO, CAL.
 SEATTLE, WASH. PORTLAND, ORE.

Architects and Building Contractors!

The HICKS-JUDD COMPANY, Inc., and SUNSET PUBLISHING HOUSE
 have consolidated under the name of
 ABBOTT-BRADY PRINTING CORPORATION
 460 Fourth Street, San Francisco, Calif.

THE Binding of Magazines and Periodicals
 will continue as one of Our Specialties;
 also Expert Plate and Map Mounting.

Reprinting of The Architect and Engineer Advertisements for Circular or File Use

George S. MacGruer }
 Robert M. Simpson } Members of Builders Exchange

MacGruer & Simpson

CONTRACTING PLASTERERS

PLAIN AND ORNAMENTAL

Cement, Stucco and Artificial Stone

Phone Sutter 5688

540 Call-Post Building, San Francisco

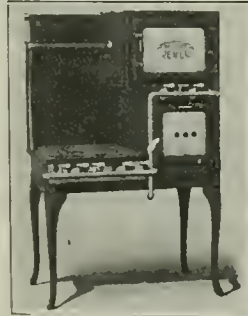

Detroit Jewel Gas Ranges

FOR HOME, RESTAURANT, HOTEL AND CLUB

We carry a Full Line of Stock Sizes

SELLING AGENTS

NATHAN DOHRMANN CO.

Geary and Stockton Streets, San Francisco

PARMELEE-DOHRMANN CO.

436-444 S. BROADWAY, LOS ANGELES

CALIFORNIA ARTISTIC METAL & WIRE CO.
 J. T. McCORMICK, PRESIDENT
 ORNAMENTAL IRON AND BRONZE
 349-365 SEVENTH ST. SAN FRANCISCO

MORTENSON CONSTRUCTION CO.
 CONTRACTORS FOR STRUCTURAL STEEL AND IRON
 H. MORTENSON, PRES. CHAS. G. MORTENSON, VICE-PRES. AND MGR.
 OFFICE AND SHOPS: CORNER 19TH AND INDIANA STREETS
 PHONE: MISSION 5033 SAN FRANCISCO, CAL.

RAYMOND GRANITE COMPANY, Inc.
 Owning and operating at Knowles, Madera County, the largest Quarry in the world
 CONTRACTORS FOR STONE WORK
 Designers and Manufacturers of Exclusive Monuments and Mausoleums
 Main Office and Yard: No. 1 and 3 Potrero Avenue, San Francisco, California
 Also at 1350-Palmetto Street, Los Angeles

CAEN STONE  **A. KNOWLES**
 A refined, elegant, interior finish. CONTRACTOR and PLASTERER
 442 Call-Post Building San Francisco

ZOURI SAFETY SASH BARS
 Accepted by the Insurance Underwriters for Safety Setting of Plate Glass used in Store Front Construction.
 **COBBLEDICK-KIBBE GLASS CO.**
 175 JESSIE ST. WASHINGTON AT THIRD ST.
 SAN FRANCISCO, CAL. OAKLAND, CAL.

Telephone Mission 58 A. A. Devoto, President
CENTRAL IRON WORKS, Inc.
 STRUCTURAL STEEL
 Office 2050 BRYANT STREET SAN FRANCISCO, CAL.

JOHNS-MANVILLE
 SERVES IN CONSERVATION
 Through
ASBESTOS and its ALLIED PRODUCTS

 **SCHRADER IRON WORKS, Inc.**
 STRUCTURAL STEEL CONTRACTORS
 Fire Escapes, Waterproof Trap Doors, Ornamental Iron Work
 1247-1249 HARRISON STREET SAN FRANCISCO, CAL.
 Bet. 8th and 9th Telephone Market 337

THE HYLOPLATE BLACKBOARD

SCHOOL FURNITURE
AUDITORIUM SEATING

MAPS
GLOBES
ATLASES

C. F. WEBER & CO.

985 Market Street
SAN FRANCISCO

222-224
S. Los Angeles St.
LOS ANGELES

100 W. Commercial
Row, RENO, NEV.

524 W. Washington
Street, PHOENIX, ARIZ.



Smaller Up-Keep
Roofing, sheathing, siding, foundation—all industrial construction—gives longer and better service with less up-keep if built of California Redwood. Contains a natural preservative—resists rot.

Write for "Redwood for the Engineer," "Specialty Uses of Redwood," and "Redwood Block Paving and Flooring."

CALIFORNIA REDWOOD ASSOCIATION
San Francisco

California Redwood

Resists fire and rot



**BEAUTIFUL GARDEN
EFFECTS** for the City
and Suburban Home

MacRORIE-McLAREN CO.

Landscape Engineers
and General Nurserymen



Office
141 Powell Street
San Francisco

Nurseries at
Beresford,
San Mateo County

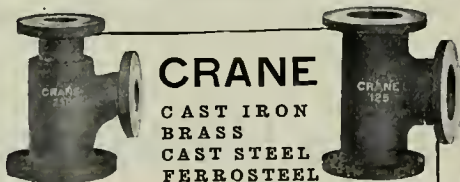

CRANE
CAST IRON
BRASS
CAST STEEL
FERROSTEEL

FLANGED FITTINGS

We have the largest line of patterns for flanged fittings for low pressure, standard, extra heavy, hydraulic, superheated and extreme hydraulic pressures, ranging in size from one-inch to sixty-inch, and for working pressures from fifty pounds to three thousand pounds.

The dimensions of the low pressure, standard and extra heavy fittings are in accordance with the 1915 American Standard.

Castings for special fittings also may be made at a minimum expense owing to our large equipment of special patterns which may be altered at very low cost.

CRANE CO.

PLUMBING SUPPLIES

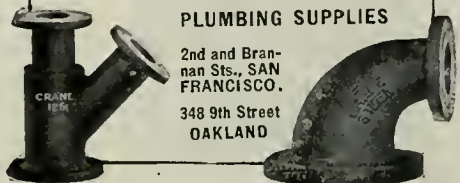

2nd and Bran-
nan Sts., SAN
FRANCISCO.

348 9th Street
OAKLAND

Telephone DOUGLAS 2046	<div style="border: 1px solid black; padding: 5px;"> <p style="font-size: small; margin: 0;">Butte Electrical Equipment Company</p> <h1 style="margin: 0;">BEECO</h1> <p style="font-size: x-small; margin: 0;">TRADE MARK-REG</p> </div>	530 FOLSOM STREET
CONTRACTORS FOR POWER LIGHTING AND INDUSTRIAL INSTALLATIONS		
For the convenience and guidance of our customers, we have adopted BEECO as our trade name.		

<h1 style="margin: 0;">SAFETY ELECTRIC COMPANY</h1>		
MANUFACTURERS OF		
SWITCHBOARDS SAFETY SWITCHES SAFETY CONTROLS		PANEL BOARDS SAFETY PANELS KNIFE SWITCHES
59-65 Columbia Square		San Francisco, Calif.
Telephone Market 2949		

L. SIEBERT	J. GENSLER
<h1 style="margin: 0;">Drendell Electrical & Mfg. Co.</h1>	
Incorporated	
SWITCHBOARDS, PANEL BOARDS, KNIFE SWITCHES, CABINETS, THEATRE INSTALLATIONS, PROTECTIVE POWER PANELS	
1345-1353 Howard St., San Francisco	Telephone Market 1753

 <p style="font-size: x-small; margin: 0;">"TYPE C"</p>	<h2 style="margin: 0;">Western Safety Man'fg. Co. Inc.</h2> <p style="font-size: small; margin: 0;">Formerly MEYERS ELECTRIC SAFETY SWITCH CO., Inc.</p> <p style="font-size: x-small; margin: 0;">Manufacturers of</p> <p style="margin: 0;">Enclosed Externally Operated Safety Switches, Knife Switches, Metal Switch and Cut Out Boxes, Safety Switch Boards</p> <p style="margin: 0;">Office, 247 Minna Street SAN FRANCISCO Telephone, Sutter 3008</p>
--	---

BUTTE ELECTRIC & MFG. CO. DOUGLAS 145
 (Paul C. Butte) at it since 1904
WIRING FOR BUILDINGS
 534 Folsom Street SAN FRANCISCO

H. S. TITTLE
CONTRACTING ELECTRICAL ENGINEER
 766 FOLSOM ST., SAN FRANCISCO Phone SUTTER 4278



To Be "Low Bidder" Not Always Our Aim.
 Our most particular attention is given to prompt and skillful handling of all electrical work of any nature with "QUALITY AND SERVICE GUARANTEED."
 Our nation-wide organization and large experience in this field assures you always of fair estimates and absolute satisfaction.

F. E. NEWBERY ELECTRIC CO.
 163 Sutter St. (413 Lick Bldg.) San Francisco, Phone Sutter 521

San Francisco, Cal. Oakland, Cal. Los Angeles, Cal.
NEPAGE, McKENNY CO.
Electrical Engineers and Contractors
 Phone Sutter 2369 589 Howard St., San Francisco, Cal.

Phone Market 2541 M. FLATLAND
GLOBE ELECTRIC WORKS
 Estimates Furnished on Everything Electrical
ELECTRIC SUPPLIES
 1959 Mission Street, bet. 15th and 16th SAN FRANCISCO

E. E. BROWNE Telephone Douglas 976 C. A. LANGLAIS
BROWNE-LANGLAIS ELECTRICAL CONSTRUCTION COMPANY
 213 Minna Street SAN FRANCISCO

M. E. RYAN
Electrical Contractor
 Phones: Store, Red. 250J 216 Main Street
 Residence, Red. 250M REDWOOD CITY, CAL.

CHAS. G. FRIES. TELEPHONE SUTTER 5706 VICTOR A. KUEHN
LIBERTY ELECTRIC COMPANY
 479 Sutter St. **Electrical Contractors** San Francisco, Cal.

Oakland 540

The Largest Exclusive Electrical House in the State

MOTORS

BOUGHT — SOLD
RENTED—REPAIRED

Lighting Fixtures

Manufactured

Construction

MAINTENANCE
SUPPLIES

Estimates and engineering data cheerfully furnished

SPOTT ELECTRICAL CO.

Yours for Service

16th & CLAY STREETS

OAKLAND, CALIFORNIA

KLINGSTONE

WILL NOT CRACK

Modern Flooring Requirements

¶ In this day of modern building construction, sanitary and fireproof requirements are sought by the architect in building specifications.

Klingstone Sanitary Flooring Rates 82%

—Cork tile, 72%; linoleum, 70%; oak or maple, 63%; white pine 62%; marble, 52%; rubber tile, 49%; clay tile, 43%; terrazo 43%; Portland Cement concrete, 42%; common brick rating 25%. ¶ KLINGSTONE SANITARY FLOORING is being extensively used in modern office buildings, schools, hospitals, factories, churches, railroad cars, steamships, hotels, public buildings, theatres, banks, stores, restaurants, cafes, garages, dairies, creameries, high-class residences and apartment houses.

¶ **GUARANTEE.** — We rigidly guarantee our KLINGSTONE Sanitary Flooring, and where applied according to our printed specifications, will replace, free of charge, any defective material, including labor for installing same.

NATIONAL MAGNESITE PRODUCTS CORPORATION

833 MARKET STREET, SAN FRANCISCO

A. H. Bergstrom
Eric Lange

S. F. Phone Kearny 3526

LANGE & BERGSTROM

Building Contractors

(Established 1900)

207-210 SHARON BLDG.
San Francisco

WASHINGTON BLDG.
Los Angeles

TIMKEN BLDG.
San Diego

CONTRACTOR'S MACHINERY

RANSOME MIXERS

OSHKOSH MIXERS

INSLEY SPOUTING PLANTS

OSHKOSH EVEREADY SAW RIGS INSLEY STEEL CARS and TRACKS
HOISTING BUCKETS, HOPPERS, GATES, ETC.

STEAM AND ELECTRIC HOISTS

EVERYTHING USED BY CONTRACTORS

CARRIED IN STOCK BY

GARFIELD & CO.

Hearst Building, San Francisco

Phone Sutter 1036

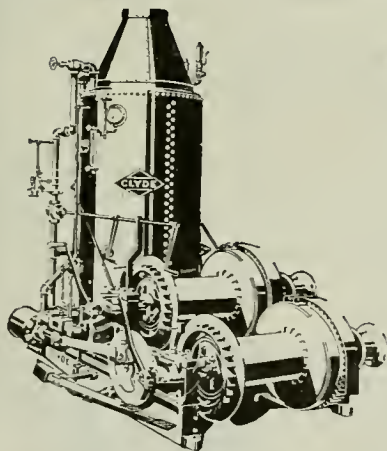

CLYDE HOISTS

— With a record of service worthy of the praise it receives — and meriting your consideration whenever you are in need of reliable, steady service —

Whatever your need **CLYDE** meets it

Smith-Booth-Usher Co.

PUMPS - ENGINES - MOTORS - MACHINERY - SUPPLIES

SAN FRANCISCO
50-60 Fremont St.

LOS ANGELES
228-38 Central Ave.

LANNOM BROTHERS MFG. CO.

Hardwood Interior
Finish a Specialty

MILL WORK, SASH and DOORS

Veneered Doors
and Panels

Telephone Oakland 241

Fifth and Magnolia Sts., Oakland

MILLWORK Manufactured and Delivered Anywhere

Plans or Lists sent us for Estimates will have Careful and Immediate Attention.

Jno. Dudfield, Pres.
and Manager

DUDFIELD LUMBER CO.

Joseph A. Jury,
Sec'y & Mill Supt.

MAIN OFFICE, YARD AND PLANING MILL — PALO ALTO, CALIFORNIA

FRANK PORTMAN

MILL AND CABINET WORK

Window Frames and Inside Finish A Specialty
Band Sawing, Sticking and Sand Papering

1618-20 MISSION STREET

SAN FRANCISCO

ALL KINDS OF
MOULDINGS
IN STOCK

Phone Park 6204

A. C. SCHINDLER, President.

CHAS. F. STAUFFACHER, Secretary

THE FINK & SCHINDLER CO.

Manufacturers of INTERIOR WOODWORK AND FIXTURES
BANK, OFFICE AND STORE FITTINGS
SPECIAL FURNITURE

218-228 THIRTEENTH ST.
Bet. Mission and Howard Sts.

SAN FRANCISCO, CAL.
Telephone: Market 474

O. BAMANN, President

ERNEST HELD, Vice-President

HOME MANUFACTURING CO.

BANK, STORE AND OFFICE FITTINGS
FURNITURE AND HARDWOOD INTERIORS
CABINET WORK OF EVERY DESCRIPTION

543 and 545 BRANNAN ST.

Phone Kearny 1514

San Francisco, Cal.

JAMES L. McLAUGHLIN

GENERAL CONTRACTOR

Phone Kearny 4654

251 KEARNY STREET, SAN FRANCISCO

MULLEN MANUFACTURING CO.

BANK, STORE AND OFFICE FIXTURES—CABINET WORK OF
GUARANTEED QUALITY—CHURCH SEATING

Telephone Market 8692

Office and Factory:
64 Rausch St., Bet. 7th and 8th Sts., San Francisco

Dolan Wrecking & Construction Co.

(D. J. DOLAN)

Lumber, Lath, Nails, Shingles, Doors, Windows
and Plumbing Supplies, New and Second Hand

Phone Market 4264

Office and Yard, 1607-1639 MARKET ST., SAN FRANCISCO

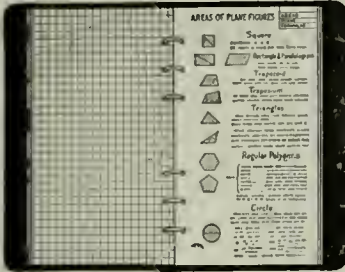

LEFAX

LEAF + FACTS

Pocket Cyclopedias

The facts that you want *instantly available* are not the same ones that some one else in your profession might desire. That's why LEFAX is made Loose Leaf. You file, in whatever order you wish, those sheets of facts that you want to have constantly at hand. If you wish, you may also file, in the same book, sheets for keeping data, for figuring, etc.

LEFAX sets cost but 50c. and \$1.00. You cannot fully appreciate their handiness—their value—until you use them. Ask us about them.

SCHWABACHER-FREY STATIONERY CO.
 PRINTERS LITHOGRAPHERS STATIONERS
 611 Market Street San Francisco

Steam Heating and Ventilating



For Commercial and Public Buildings

Furnace Heating
 For the Home

Mangrum & Otter, Inc.

827-831 Mission Street

Phone Kearny 3155 SAN FRANCISCO

"Talk—Don't Walk"

Baker, Hamilton & Pacific Co.; California Packing Corporation; J. Barth & Company; Robert Dollar Company; Bass-Hueter Paint Co.; Sperry Flour Company, So. Vallejo; J. D. & A. B. Spreckles Securities Co.

WHY are the above firms using the AUTOMATIC PRIVATE TELEPHONE SYSTEM?

BALFOUR, GUTHRIE Co.; HOWARD AUTOMOBILE COMPANY; U. S. MARINE HOSPITAL KNOW WHY, and are also installing the AUTOMATIC PRIVATE TELEPHONE SYSTEM.



DIRECT-LINE TELEPHONE COMPANY

Telephone Electrical Engineers

THEODORE HALL, MANAGER

320 MARKET STREET, SAN FRANCISCO

Phone Douglas 722

Have you read "A Pair of Wires and A Dial?"

ROBERTS MFG. CO.

Lighting Fixtures
 Electric Appliances
 Incandescent Lamps

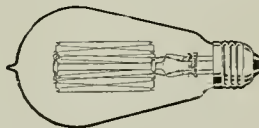

WILLYS FARM LIGHTING AND POWER PLANTS

663 Mission St., San Francisco

Washed Gravel and Sand

Quality For Concrete Construction *Service*

Thoroughly Washed and Accurately Graded—An Ideal Concrete Aggregate



View of Plant at Niles

California Building Material Co.

Plants at Eliot and Niles, Cal.

500 Call Building, San Francisco

Otis Elevators

THE Architect or Engineer can specify "Otis Elevators" assured that the responsibility of the Otis Elevator Company extends beyond satisfactory installation. Buildings equipped with Otis Elevators enjoy the advantage of the prompt service and careful inspection rendered by any of our hundred offices. Such service means your clients' gratitude.



Otis Elevator Company

Offices in All Principal Cities of the World
2300 Stockton Street, San Francisco, Calif.

THE UNIVERSITY OF CALIFORNIA
PUBLIC LIBRARY

The ARCHITECT & ENGINEER



APRIL 1921

*Published in San Francisco
35 cents a copy - \$2⁵⁰ a year*

Announcing Catalogue G

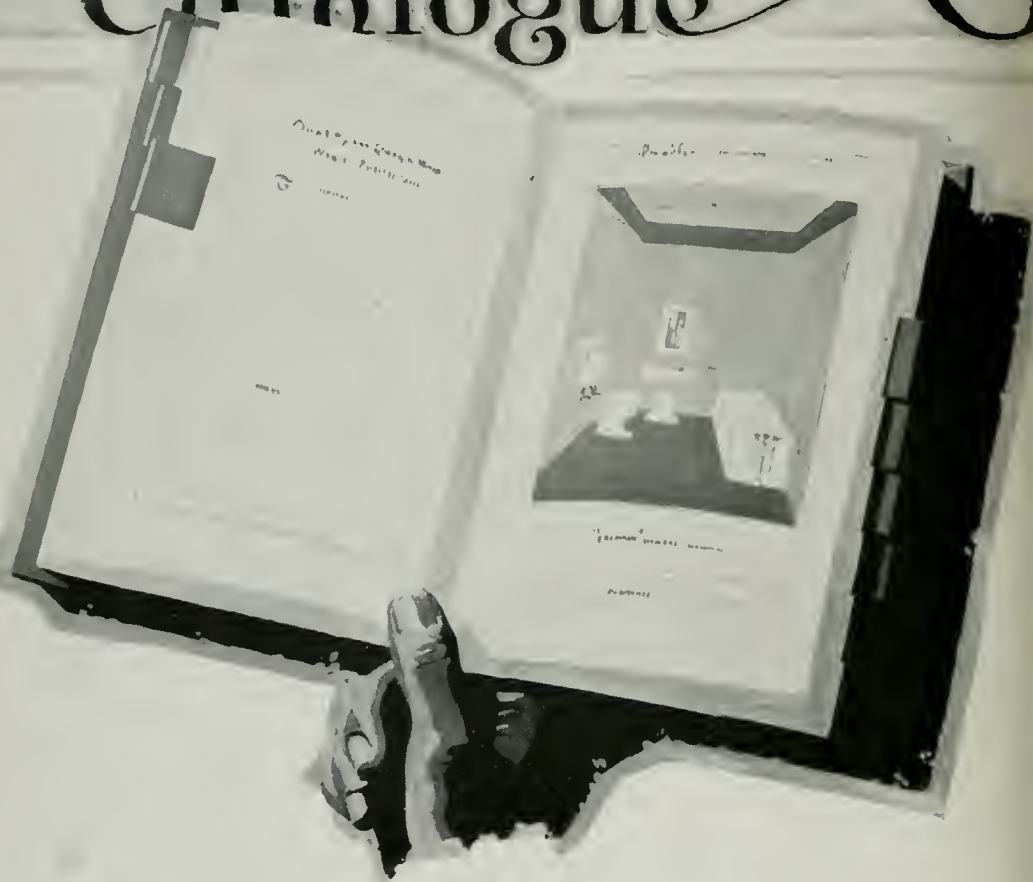

DUE off the press in May. A reference book that you will find extremely valuable. Contains illustrations of our entire line with complete specifications and descriptions—convenient tabs that make the finding of any fixture easy. A handy size; 6 by 9 inches.

So that your copy of Catalogue G and subsequent supplements will surely reach you promptly, please make out and mail us the coupon.

PACIFIC **PLUMBING & FIXTURES**

For Sale by All Jobbers

Main Offices: 67 New Montgomery Street, San Francisco
Factories: San Pablo and Richmond, California

Kindly send a copy of Catalogue G to

Name

Address

.....

*New Academy of Sciences, Golden Gate Park,
San Francisco
Covered with a PABCO 10-Year Roof*

PABCO ROOFS for Public Buildings

Many of the beautiful and notable public buildings on the Pacific Coast are covered with PABCO ROOFS. Architects, Engineers and State and Municipal Officials know that these time-tested roofs provide, even under the most severe conditions, lasting protection at minimum cost.

PABCO 10 and 20-Year Roofs

Because of the high quality of materials used, and the admitted superior methods of construction, PABCO ROOFS cost slightly more at the outset, than inferior and short lived roofs. Invariably, however, they prove cheaper in the long run, because of their low cost per year of service.

Write for Specifications and
Complete Details

THE PARAFFINE COMPANIES, INC.
San Francisco, California

Lewis P Hobart
Architect



Roofings, Felts
Roof Coatings
Building Papers
Wall-Boards
Floor Covering
Waterproofing
Materials
Paints
Electrical Varnishes
and Insulating
Compounds
Box-Board
Paper-Boxes
Fibre Containers

*"Each the standard
of its kind"*

Clocks were Never Needed 'Til Time Acquired a Value



"ISH-KA-
BIBBLE"



Electric Clock and Program Bell Systems,
Automatic Control of Time Keeping Devices
for Schools, Hospitals, Public and Private
Buildings, Banks Etc., Automatic Calling
Systems

Please Note

Right here on the Pacific Coast we are manufacturing and distributing Electric Clocks, designed and engineered by J. J. Estabrook, a man who knows how with twenty-five years' experience—nine years on the Pacific Coast.

Plans, specifications and any engineering information, estimates, etc., cheerfully furnished to architects, engineers or any one interested in this special line of work.

SERVICE

is our motto

PACIFIC ELECTRIC CLOCK CO.

J. J. ESTABROOK

516 Wells Fargo Building

San Francisco, Calif. Telephone Sutter 803

General Machinery & Supply Co.

OFFICES AND STORE: 39-51 STEVENSON STREET
TELEPHONE - PRIVATE EXCHANGE - SUTTER 6750

— AGENTS FOR —

EVERLASTING BLOW-OFF VALVES

WM. POWELL CO.'S { WHITE STAR VALVES - MODEL STAR VALVES
UNION COMPOSITE DISC VALVES AND PILOT GATE VALVES

YALE & TOWNE:—CHAIN HOISTS

FISHER AND SWARTWOUT STEAM SPECIALTIES

ENGINEER'S, MACHINIST'S AND STEAM FITTER'S SUPPLIES
PIPE, PIPE-FITTINGS, VALVES, BELTING, PACKING AND HOSE
TRANSMISSION AND CONVEYING MACHINERY

SEND US YOUR INQUIRIES

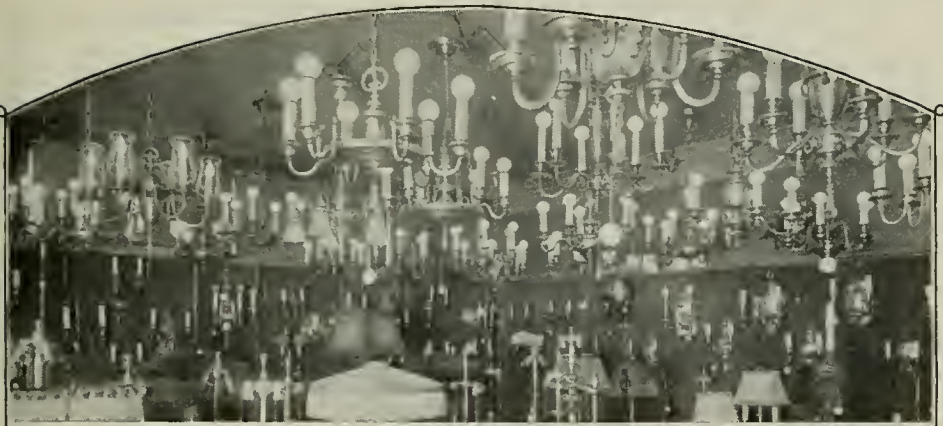

Elexits

"Places for Lights"



This compact little plug, with or without a special hickey, makes practically any type of wall bracket ready to plug into a wall Elexit anywhere, any time, as occasion may require.



Front view of the Elexit receptacle. This universal receptacle with circular or rectangular flush plate can be attached to virtually all types of outlet boxes in either ceiling or wall. It gives you a finished inconspicuous outlet, ready at any time to receive either the Elexit fixture-supporting plugs, or the standard attachment plugs now found on practically all electrical appliances.



The two piece ceiling plug that makes nearly every type of chandelier or hanging fixture lock itself securely, by its own weight, into any ceiling Elexit.



Cap of the standard attachment plug that fits all Elexits and is now found on most electrical appliances.

"Elexit" is a name-word coined by the Electric Outlet Company, Inc., to describe any electric outlet equipped with a receptacle licensed under the patents owned by the Electric Outlet Company, Inc., and conforming to carefully standardized measurements to insure uniform service.



The names and addresses of all manufacturers licensed to make Elexit receptacles and plugs will be furnished upon request to any electrical contractor or lighting fixture manufacturer. Requests for further details will be welcomed.

ELECTRIC OUTLET COMPANY Inc. 119 West 40th St., New York City

When writing to Advertisers please mention this magazine.

When Choosing Electric Time Equipment you certainly want **THE BEST.**

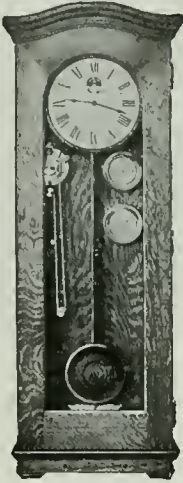

"Standard" electric time equipment watches over the precious minutes of school days, preventing too much time being used for one subject at the expense of another, simplifying the whole school routine and promoting punctuality and efficiency among both pupils and teachers. Perfected through 36 years' experience. Each equipment carefully engineered to fit requirements. Helpful co-operation furnished architects, contractors, and school boards, insuring satisfaction.

STANDARD ELECTRIC TIME COMPANY

461 MARKET STREET

Phone Sutter 241

SAN FRANCISCO

DEPENDABILITY
"Since 1858"
LINOLEUMS
WINDOW SHADES

Carpets
Draperies
Rugs

Estimates Furnished

D. N. & E.
Walter & Co.

562-572 Mission Street
SAN FRANCISCO

Lcs Angeles

Portland

Seattle



PROMETHEUS

The Electric Food and Plate Warmer

Wherever meals are cooked and served, in apartments, residences and institutions, Prometheus is a highly valued asset. The wireless heating units placed independently of the shelves keep food hot and tasty until ready to serve and cannot injure the finest china.

Write for information and list of installations

The Prometheus Electric Co.

Manufacturers

511 West 42d Street, New York

Showroom. **M. E. HAMMOND**

Mezzanine Floor Pacific Bldg., San Francisco



IT'S not enough to say "Good For All Time" unless there is something back of it. ¶ There is in this case. ¶ Vermont Marble already has an unblemished record of over one hundred and fifty years. ¶ We know what it will do. It's not necessary to guess at it. ¶ And our quarries in Alaska and Texas are also proving themselves. ¶ So please don't think of "Good for All Time" as merely a happy phrase.

IT'S THE MARK OF A SERVICE.
It means exactly what it says.

Vermont Marble Company
PROCTOR, VERMONT

San Francisco - Portland - Tacoma

STEEL BARS

FOR

CONCRETE REINFORCEMENT

CORRUGATED
TWISTED
SQUARES
OR
ROUNDS
CUT
TO
LENGTH



FABRICATED
AND
INSTALLED
—
LUMP SUM
BIDS
ON
WORK
COMPLETE

Office, 444 MARKET STREET
Warehouse, 10th and Bryant Streets
Phone: Sutter 2720

“HYDRATITE” FOR WATERPROOFING AND “HORNSTONE”
HARDENING CONCRETE

How daylight helps workmen do more and better work



DAYLIGHT and fresh air are powerful aids to production. The stimulus of plenty of light and fresh air is reflected in greater volume and accuracy of output, with diminished wastage. Operatives enjoy better health, are freer from eye-strain, lose fewer days through sickness. Labor turnover is reduced—output is noticeably increased. All of this is accomplished with TRUSCON Daylight Sash.

Truscon Daylight Engineers at your Service

All sizes of Truscon Steel Sash carried in stock in San Francisco Warehouse.

Largest stock of fireproof material and reinforcing bars on the Pacific Coast.

TRUSCON STEEL COMPANY

CHAS. HOLLOWAY, JR., Branch Manager

527 Tenth Street, San Francisco



TRUSCON DAYLIGHT SASH

E. B. Noble, President
A. E. Wilkins, Vice-Pres.

Beam, Angle, Channels, and Universal Mill
Plates for immediate shipment from stock

Pacific Rolling Mill Co.

SUPPLIERS OF

**FABRICATED STRUCTURAL STEEL, Forgings,
Bolts, Rivets, Frogs, Switches, Cast Iron Castings**

General Office and Works
17th and MISSISSIPPI STS., SAN FRANCISCO
Telephone Market 215

Beams
Channels
Angles
Plates

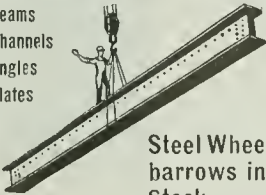

Steel Wheel-
barrows in
Stock

Western Iron Works

W. B. MORRIS, Pres. H. H. MORRIS, V.-P. L. J. GATES, Sec.

**STRUCTURAL IRON AND
STEEL CONTRACTORS**

141-147 Beale St. and 132-148 Main St. SAN FRANCISCO

Phones: GARFIELD 2575--2576

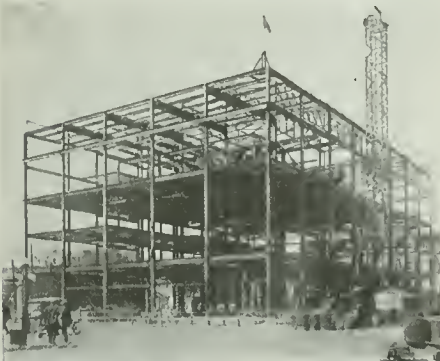

STEEL FRAME, MASONIC TEMPLE,
Sacramento. R. A. HEROLD, Architect.

STRUCTURAL STEEL
(600 tons) Fabricated and
Erected by

**THE PALM IRON AND
BRIDGE WORKS** (Incorporated)
15th and R Streets, Sacramento, Cal.

Cast Iron Stairs and Store Fronts

Bank and Office Railings, Elevator
Enclosures and Fire Escapes.

C. J. HILLARD CO., Inc:

Nineteenth and Minnesota Streets
Telephone Mission 1763

SAN FRANCISCO, CAL.

Architects' Specification Index

(For Index to Advertisements, see next page)

ART METAL

American Art Metal Works, 13 Grace street,
San Francisco.

ARCHITECTURAL TERRA COTTA

Gladding, McBean & Company, Crocker Bldg.,
San Francisco.

Livermore Fire Brick Works, 604 Mission street,
San Francisco.

ASBESTOS ROOFING, PACKING, ETC.

H. H. Robertson Co., Hobart Bldg., San Francisco.

H. W. Johns-Manville Co., San Francisco, Los
Angeles and Portland, Ore.

AUTOMATIC SPRINKLERS

Grinnell Co. of the Pacific, 453 Mission St., San
Francisco.

Pacific Fire Extinguisher Co., 424 Howard St.,
San Francisco.

AUTOMOBILE INSURANCE

Bankers & Shippers Insurance Co. of New York,
Insurance Exchange Bldg., San Francisco.

AUTOMOBILES

W. L. Hughson Co., Geary St., at Van Ness Ave.,
San Francisco.

AWNINGS, TENTS, ETC.

W. A. Plummer, Front, at Pine St., San Fran-
cisco.

BANKS

First National Bank, Post and Montgomery
streets, San Francisco.

BANK FIXTURES AND INTERIORS

Fink & Schindler, 218 13th St., San Francisco.

C. F. Weber & Co., 985 Market St., San Fran-
cisco.

Home Mfg. Co., 543 Brannan St., San Fran-
cisco.

Mullen Manufacturing Co., 64 Rausch St., San
Francisco.

Rucker-Fuller Desk Co., 677 Mission St., San
Francisco.

Pacific Manufacturing Company, San Francisco,
Los Angeles, Oakland and Santa Clara.

BELTING AND PACKING

New York Belting and Packing Company, 519
Mission St., San Francisco.

H. N. Cook Belting Co., 401 Howard St., San
Francisco.

Smith-Booth-Usher Co., San Francisco and Los
Angeles.

BLACKBOARDS

C. F. Weber & Co., 985 Market St., San Fran-
cisco, Los Angeles and Reno, Nevada.

Beaver Blackboards and Greenboards, Rucker-
Fuller Desk Company, Coast agents 677 Mis-
sion St., San Francisco; also Oakland and
Los Angeles.

BLINDS—VENETIAN AND DIFFUSELITE

J. G. Wilson Corporation, Metropolitan Bldg.,
Los Angeles; Waterhouse-Wilcox, Underwood
Bldg., San Francisco.

Western Venetian Blind Co., Long Beach Ave.,
Los Angeles; C. F. Weber & Co., San Fran-
cisco.

BOILERS

California Hydraulic Engineering & Supply Co.,
70-72 Fremont St., San Francisco.

General Boilers Co., 322 Monadnock Bldg., San
Francisco.

Kewanee Water Supply System, Simonds Ma-
chinery Co., 117 New Montgomery St., San
Francisco.

BOOK BINDERS

Abbott-Brady Printing Corp'n, 460 Fourth St.,
San Francisco.

H. S. Crocker Co., 565 Market St., San Fran-
cisco.

BONDS FOR CONTRACTORS

American Mutual Liability Insurance Co., Balboa
Bldg., San Francisco.

Bonding Company of America, Kohl Bldg., San
Francisco.

Bankers & Shippers Insurance Co. of New York,
Insurance Exchange Bldg., San Francisco.

Globe Indemnity Co., 120 Leidesdorff St., San
Francisco.

Fidelity & Casualty Co. of New York, Merchants
Exchange Bldg., San Francisco.

John H. Robertson, 621 First National Bank
Building, San Francisco.

National Surety Co. of New York, 105 Mont-
gomery St., San Francisco.

BRASS GOODS, CASTINGS, ETC.

H. Mueller Manufacturing Co., 635 Mission St.,
San Francisco.

BRICK, PRESSED, PAVING, ETC.

California Brick Company, 604 Mission street,
San Francisco.

Livermore Fire Brick Works, 604 Mission street,
San Francisco.

Los Angeles Pressed Brick Co., Frost Bldg., Los
Angeles.

United Materials Co., Crossley Bldg., San Fran-
cisco.

Cannon & Co., Sacramento; and 77 O'Farrell
street, San Francisco.

BRICK & CEMENT COATING

Armorite and Concreta, manufactured by W. P.
Fuller & Co., all principal Coast cities.

The Paraffine Companies, Inc., 34 First St., San
Francisco.

R. N. Nason & Co., 151 Potrero Ave., San
Francisco.

Wadsworth, Howland & Co., Inc., Boston, Mass.,
manufacturers of Bay State Brick & Cement
Coating. Hambley & Son, agents, San Fran-
cisco and Los Angeles.

BRICK STAINS

Samuel Cabot Mfg. Co., Boston, Mass., agencies
in San Francisco, Oakland, Los Angeles, Port-
land, Tacoma and Spokane.

Armorite and Concreta, manufactured by W. P.
Fuller & Co., all principal Coast cities.

BUILDERS' HARDWARE

Joost Bros., agents for Russell & Erwin Hard-
ware, 1053 Market St., San Francisco.

The Stanley Works, New Britain, Conn., repre-
sented in San Francisco and Los Angeles by
John Rountree & Co.

Palace Hardware Company, Agents Corbin goods,
581 Market St., San Francisco.

Richards-Wilcox Mfg. Co., Aurora; Ewing-Lewis
Co., 626 Underwood Bldg., San Francisco.

GRINNELL AUTOMATIC SPRINKLER GRINNELL COMPANY

OF THE PACIFIC

ENGINEERS AND CONTRACTORS
453 Mission Street, San Francisco

VALVES
PIPE and FITTINGS

CHEMICAL FIRE
EXTINGUISHERS
and FIRE ENGINES

An Index to the Advertisements

	Page		Page		Page
Abbott-Brady Printing Corp.	151	Globe Indemnity Co.	150	Pacific Pump & Supply Co.	38
All-in-One	123	Grinnell Co.	7	Pacific Rolling Mills	6
American Art Metal Works	156	Gunn Carle Company	5	Palace Hardware Co.	38
American Face Brick Ass'n.	129	Haines, Jones & Cadbury	131	Palm Iron Works	6
American Insulex Co.	22	Hamilton, John E.	139	Palmer & Petersen	142
American La France Fire Engine Co.	122	Hannah, J. D.	142	Paraffine Companies, Inc.	1
American Mutual Liability Insurance Co.	10	Haus Window Co.	36	Parker, K. E. Co., Inc.	144
American Mail Chute	28	Haws Sanitary Drinking Faucet Co.	138	Petrium Sanitary Sink Co.	141
American Marble & Mosaic Co.	44	Hill, Hubbell Co.	37	Phillips, Chas. T.	145
American Rolling Mill Co.	134-135	Hillard, C. J., Co.	6	Pitcher Door Hanger	25
American Window Glass Co.	42	Holbrook, Merrill & Stetson	147	Pittsburg Water Heater Co.	148
Anderson, V. A.	17	Home Mfg. Co.	158	Planing Mill Listing Bureau	124
Atlas Heating & Ventilating Co.	146	Hughson, W. L. Co.	26	Plummer, W. A.	138
Atlas Portland Cement Co.	119	Humphrey Radiantfire	25	Pope & Talbot	15
Bacon, Edward R., Co.	132	Hunt, Robt. W. & Co.	132	Portman, Frank	158
Badt-Falk & Co.	145	Hunter & Hudson	140	Prometheus Electric Co.	4
Baird-Bailhache Company	34	Ideal Heating & Engineering Co.	146	Raymond Granite Co.	152
Bankers' & Shippers' Ins. Co.	132	Illinois Engineering Co.	146	Reliance-Grant Elevator Equipment Co.	22
Barrett & Hilp	144	Imp Mfg. Co.	148	Richard Wilcox	31
Bartlett, John M.	136	Imperial Waterproofing	28	Roberts Mfg. Co.	159
Bass-Hueter Co.	3rd Cover	James & Drucker	146	Robertson Co., H. H.	11
Beach-Robinson Co.	27	Jarvis, T. P. Mfg. Co.	43	Robertson, John H.	150
Beckwith, Herbert	145	Johns-Manville Co.	152	Ruegg Bros.	150
Bowser & Co., S. F.	41	Johnson, S. T.	43	Rucker-Fuller Desk Co.	140
Breuner, John	136	Johnson Service Co.	11	Ryan, M. E.	136
Brininstool Co.	22	Joost Brothers	140	Safety Electric Co.	154
Browne-Langlais Company	155	Kaewner Mfg. Co.	143	Sampson Spout Cord	136
Builders and Roofers Exchange	140	Kerner Incinerator Co.	42	Santa Fe Lumber Co.	15
Bunting Iron Works	43	Kissel, I. R.	142	Scott Co.	146
Butte Electrical Equipment Co.	154	Knittle-Cashel Co., Inc.	13	Schrader Iron Works	152
Butte Electric & Mfg. Co.	155	Knowles, A.	152	Schwabacher-Frey Co.	159
Cabot, Samuel (Inc.)	41	Lannom Bros. Mfg. Co.	158	Simmons, O. M. Co.	12
California Artistic Metal and Wire Co.	152	Lange & Bergstrom	157	Simonds Machinery Co.	127
California Bldg. Material Co.	160	Leiter, E. T. & Son	136	Smith-Booth-Usher Co.	157
California Brick Co.	33	Liberty Electric Co.	155	Smith, Jas. F.	144
California Granite Co.	146	Littlefield, R. W.	144	Sommer, I. M.	144
California Hydraulic Engineering and Supply Co.	10	Livermore Fire Brick Works	33	Sonnenschein Bros.	27
California Plastic Products Co.	137	Los Angeles Pressed Brick Co.	128	Soulé, Edward L. Co.	132
California Redwood Ass'n.	153	MacGruer & Simpson	151	Spencer Electric Co.	155
California Steam and Plumbing Supply Co.	137	MacRorie-McLaren Co.	153	Spencer Elevator Co.	34
Cannon & Co.	24	Magner Bros.	140	Spott Electrical Co.	156
Cement Gun Construction Co.	148	Mangrum & Otter	159	Standard Metal Mfrs.	130
Central Electric Co.	148	Marshall & Stearns Co.	141	Standard Varnish Works	116
Central Iron Works	152	Marten & Fredericks	145	Standard Electric Time Co.	4
Cobbledick-Kibbe Glass Co.	152	McClenahan Products Co.	148	Standard Fence Co.	145
Coleman, Alex	146	McCray Refrigerator Co.	28	Stanley Works, The	113
Collman & Speidel	142	McLaughlin, Jas. L.	158	Steelform Contracting Co.	144
Cook Belting Co.	38	McLeran & Peterson	150	St. Francis Hotel	127
Cowell Lime & Cement Co.	143	McNab, H. N.	145	Stockholm, Chas. & Son	136
Crane Co.	153	Medusa Cement	23	Strable Hardwood Co.	126
Crocker, H. S. Co.	121	Meese & Gottfried	118	Sunset Lumber Company	15
Davis, R. J.	9	Moline Heat	16	Tay Company, George H.	26
Del Favero and Rasori	142	Montague Range & Furnace Co.	18	Taylor Galleries	27
Del Monte Properties Co.	20	Monson Bros.	142	Tittle, H. S.	155
Detroit Steel Products Co.	44	Mortenson Construction Co.	152	Torney Co.	140
Direct Line Telephone Co.	159	Mott Co. of Calif.	18	Trost, Robt.	142
Dolan Wrecking & Construction Co.	158	Mueller Mfg. Co.	18	Truscon Steel Co.	5
Drendell Elec. & Mfg. Co.	154	Mullen Mfg. Co.	158	U-Turn-It Housekeeping System	125
Dudfield Lumber Co.	158	Mushet Co., W. E.	30	Uhl Bros.	38
Duncan, W. C.	144	Musto Sons Keenan Co.	13	Unit Construction Co.	142
Dunham, C. A. Co.	31	Myers & Schwartz	32	United Blower Co.	120
Eberhard Faber	30	Nason, R. N. & Co.	9	United Electric Co.	149
Electric Outlet Co.	3	Nathan, Dohrmann Co.	151	United Materials Co.	128
Electric Sales Service Co.	12	National Mill & Lumber Co.	29	U. S. Metal Products Co.	36
Elevator Supplies Co.	150	National Surety Co.	150	U. S. Steel Products Co.	40
Ellyer Arms Co.	140	National Terra Cotta Society	115	Van Fleet-Freear Co.	143
Fess System Co.	43	National Valve Co.	130	Vermont Marble Co.	4
Fidelity & Casualty Co. of N.Y.	150	National Window Shade Co.	120	Vukitchev & Bagge	144
Fink & Schindler Co., The	158	Nelson, James A.	18	Wadsworth, Howland & Co., Inc	126
Fire Protection Products Co.	36	Ne Page, McKenny Co.	155	Walter, D. N. & E. Co.	4
First National Bank	118	Newbery Electric Co.	155	Wayne Oil Tank & Pump Co.	29
Flagg, Edwin H., Scenic Co.	150	New York Belting and Packing Co.	137	Weber, C. F. & Co.	153
Freeman Art Shop	27	Norris Co., L. A.	28	Wentworth, F. W.	148
Fuller & Goepf	34	Oak Flooring Mfrs' Ass'n	21	West Coast Porcelain Co.	Back Cover
Fuller, W. P. Co.	19	Ocean Shore Iron Works	138	Western Blind & Screen Co.	39
Garfield Company	157	Old Mission Portland Cement Co.	35	Western Safety Mfg. Co.	154
Garnett, Young & Co.	20	Otis Elevator Co.	160	Western Iron Works	6
General Boilers Co.	24	Pacific Coast Steel Company	151	Western Pipe and Steel Co.	147
General Machinery & Supply Co.	2	Pacific Electric Clock Co.	2	White Bros.	112
Gilley-Schmid Co.	140	Pacific Fire Extinguisher Co.	143	Wilson, J. G., Corp.	133
Gladding, McBean & Co.	138	Pacific Mfg. Co.	15	Wilson, W. F. Co.	146
Globe Electric Works	155	Pacific Materials Co.	23-41-44	Witt, G. E. Co.	44
		Pacific Painting and Roofing Co.	136	Zelinsky, D. & Sons	145
		Pacific Plumbing Fixtures, 2d Cover			
		Pacific Porcelain Ware Co., 2d Cover			

Nason's Opaque Flat Finish

A Flat Washable Oil Paint, made in soft Kalsomine tints—a practical article for Walls, Ceilings, Etc. Agency for Tamm & Nolan Company's High Grade VARNISHES and FINISHES, made on the Pacific Coast to stand our climatic conditions.

R. N. NASON & CO. Paint Makers
151 Potrero Ave.—436 Market St., San Francisco—Portland-Seattle-Oregon

ARCHITECTS' SPECIFICATION INDEX—Continued

BUILDING MATERIALS, SUPPLIES, ETC.

California Brick Company, 604 Mission street, San Francisco.

Pacific Materials Co., Underwood Bldg., San Francisco.

Waterhouse-Wilcox Co., 523 Market St., San Francisco.

Johns-Manville Company, Post and Mason Sts., San Francisco.

CABINET MAKERS

Home Manufacturing Company, 543 Brannan St., San Francisco.

Fink & Schindler Co., 218 13th St., San Francisco.

Mullen Manufacturing Company, 64 Rausch St., San Francisco.

Lannon Bros. Mfg. Co., 5th and Magnolia sts., Oakland.

Pacific Mfg. Co., San Francisco, Los Angeles and Oakland.

Frank Portman, 1618 Mission St., San Francisco.

CARPETS

W. & J. Sloane, 216-228 Sutter St., San Francisco.

John Breuner Co., 281 Geary St., San Francisco.

D. N. & E. Walter, Mission near Second street, San Francisco.

CASEMENT WINDOW HARDWARE

Richards-Wilcox Mfg. Co., Aurora, Ill., and Underwood Bldg., San Francisco.

CEMENT

Atlas Portland Cement Co., all principal cities.

Mt. Diablo, sold by Henry Cowell Lime & Cement Co., 2 Market St., San Francisco.

Medusa White Portland Cement, manufactured by Sandusky Cement Co., represented in San Francisco by Pacific Building Materials Co., Underwood Bldg., San Francisco.

Old Mission Portland Cement Co., Mills Building San Francisco.

CEMENT EXTERIOR WATERPROOF PAINT

Armorite, sold by W. P. Fuller & Co., all principal Coast cities.

Ray State Brick and Cement Coating, manufactured by Wadsworth, Howland Co., Boston, Mass. James Hampley & Son, Distributors, San Francisco and Los Angeles.

Hill, Hubble & Company, No. 1 Drumm St., San Francisco.

Imperial Waterproofing, manufactured by Brooks & Doerr, Reed Baxter, agent, Merchants National Bank Bldg., San Francisco.

Medusa White Portland Cement, manufactured by Sandusky Cement Co., represented in San Francisco by Pacific Materials Co., 525 Market St., San Francisco.

CEMENT GUN

Cement Gun Construction Company of California, 701 Balboa Bldg., San Francisco.

CEMENT TESTS—CHEMICAL ENGINEERS

Robert W. Hunt & Co., 251 Kearny St., San Francisco.

CLAY PRODUCTS

California Brick Company, 604 Mission street, San Francisco.

Cannon & Co., Sacramento; and Chronicle Bldg., San Francisco.

Gladding, McBean & Co., Crocker Bldg., San Francisco.

Los Angeles Pressed Brick Co., Frost Bldg., Los Angeles.

United Materials Co., Sharon Bldg., San Francisco.

CLOCKS—ELECTRIC TIME

Pacific Electric Clock Co., 516 Wells-Fargo Bldg., San Francisco.

Standard Electric Time Co., 461 Market St., San Francisco.

COLD STORAGE PLANTS

H. W. Johns-Manville Co., Post and Mason Sts., San Francisco.

T. P. Jarvis Crude Oil Burning Co., 275 Connecticut St., San Francisco.

COMPRESSED AIR CLEANERS

United Electric Co., Canton, O., mfr. of Tuec Cleaner, sold by San Francisco Compressed Air Cleaning Co., Sutter and Stockton Sts., San Francisco.

George H. Tay Company, Mission and Second Sts., San Francisco; 10th and Harrison Sts., Oakland.

CONCRETE CONSTRUCTION

Barrett & Hilp, Sharon Bldg., San Francisco.

Clinton Construction Co., 140 Townsend street, San Francisco.

K. E. Parker Co., Inc., Clunie Bldg., San Francisco.

Palmer & Petersen, Monadnock Bldg., San Francisco.

I. M. Sommer, 401 Balboa Bldg., San Francisco.

Steelform Contracting Company, 681 Market St., San Francisco.

CONCRETE HARDENER

Gunn, Carle & Co., Inc., 444 Market street, San Francisco.

CONCRETE MIXERS

Foote and Jaeger mixers sold by Edward R. Bacon Co., 51 Minna St., San Francisco, also Los Angeles.

Ransome mixers sold by the Garfield Co., Hearst Bldg., San Francisco.

Smith-Booth-Usher Co., San Francisco and Los Angeles.

CONCRETE REINFORCEMENT

Edw. L. Soule Co., Rialto bldg., San Francisco.

United States Steel Products Co., San Francisco. Los Angeles, Portland and Seattle.

Twisted Bars. Sold by Gunn, Carle & Co., Inc., 444 Market St., San Francisco.

Clinton Welded Wire Fabric. L. A. Norris Co., 140 Townsend St., San Francisco.

Pacific Coast Steel Company, Rialto Bldg., San Francisco.

Triangle Mesh Fabric. Sales agents. Pacific Materials Co., 525 Market St., San Francisco.

Truscon Steel Co., 527 Tenth St., San Francisco.

Badt-Falk Co., Call-Post Bldg., San Francisco.

CONDUITS

Garnett Young & Co., 612 Howard St., San Francisco.

CONTRACTORS, GENERAL

Barrett & Hilp, Sharon Bldg., San Francisco.

K. E. Parker Co., Inc., Clunie Bldg., San Francisco.

R. W. Littlefield, 357 12th St., Oakland.

Unit Construction Co., Phelan Bldg., San Francisco.

J. D. Hannah, 142 Sansome St., San Francisco.

R. J. Davis

District Sales Agent

Century

**A. C. Motors
and Fans**

Complete stocks carried at: 171-173 Second St., San Francisco; 906 So. Hope St., Los Angeles

We have returned to our policy-holders annually for 33 years never less than 30% of the premium as a dividend. Dividends declared during 1919, \$2,017,893.

AMERICAN MUTUAL LIABILITY INSURANCE CO. OF BOSTON
Assets \$8,654,667 Surplus \$1,417,173

WORKMEN'S COMPENSATION, AUTOMOBILE, TEAMS AND PUBLIC LIABILITY INSURANCE

SAN FRANCISCO BRANCH OFFICE

1816 Balboa Building, Telephone Kearny 3202

N. F. Hesseltine, California Manager.

C. H. Gray, Assistant Manager.

ARCHITECTS' SPECIFICATION INDEX—Continued

- CONTRACTORS, GENERAL—Continued**
John M. Bartlett, 357 Twelfth St., Oakland.
E. T. Leiter & Son, Call-Post Bldg., San Francisco.
Chas. Stockholm & Son, Monadnock Bldg., San Francisco.
Herbert Beckwith, 323 Newton Ave., Oakland.
Collman & Speidel, 546 Monadnock Bldg., San Francisco.
Clinton Construction Company, 140 Townsend St., San Francisco.
Monson Bros., 1907 Bryant St., San Francisco.
W. C. Duncan & Co., 526 Sharon Bldg., San Francisco.
A. Knowles, Call-Post Bldg., San Francisco.
T. B. Goodwin, 180 Jessie St., San Francisco.
Lange & Bergstrom, Sharon Bldg., San Francisco.
McLeran & Peterson, Hearst Bldg., San Francisco.
Robert Trost, 26th and Howard Sts., San Francisco.
I. M. Sommer, 401 Balboa Bldg., San Francisco.
Del Favero & Rasori, 180 Jessie St., San Francisco.
Jas. L. McLaughlin, 251 Kearny street, San Francisco.
- CONTRACTORS' EQUIPMENT**
Edward R. Bacon Co., 51 Minna St., San Francisco, and Los Angeles.
Garfield & Co., Hearst Bldg., San Francisco.
Smith, Booth-Usher Co., 60 Fremont St., San Francisco; 228 Central Ave., Los Angeles.
- CONTRACTORS' INSURANCE**
Bankers & Shippers Insurance Co. of New York, Insurance Exchange Bldg., San Francisco.
- CONVEYING MACHINERY**
Meese & Gottfried, San Francisco, Los Angeles, Portland and Seattle.
- CORK TILE, INSULATION, ETC.**
Van Fleet-Freear Co., Sharon Bldg., San Francisco.
- CRUSHED ROCK**
Coast Rock & Gravel Co., Call-Post Bldg., San Francisco.
- DAMP-PROOFING COMPOUND**
Armorite Damp Resisting Paint, made by W. P. Fuller & Co., San Francisco.
Gunn, Carle & Co., Inc., 444 First street, San Francisco.
Hill, Hubbell & Company, No. 1 Drumm St., San Francisco.
Imperial Waterproofing, mfrd. by Brooks & Doerr, Reed Baxter, agent, Merchants National Bank Bldg., San Francisco.
"Pabco" Damp-Proofing Compound, sold by Paraffine Co., 34 First St., San Francisco.
- DOOR HANGERS**
Pitcher Hanger, sold by National Lumber Co., 326 Market St., San Francisco.
Reliance Hanger, sold by Waterhouse-Wilcox Co., San Francisco; D. F. Fryer & Co., B. V. Collins, Los Angeles, and Columbia Wire & Iron Works, Portland, Oregon.
Stanley Works, New Britain, Conn. John Rountree, agent, Monadnock Bldg., San Francisco.
Richards-Wilcox Mfg. Co., Underwood Bldg., San Francisco.
- DRINKING FOUNTAINS**
Haws Sanitary Drinking Faucet Co., 1808 Harmon St., Berkeley, and C. F. Weber & Co., San Francisco and Los Angeles.
Crane Company, San Francisco, Oakland, and Los Angeles.
Pacific Porcelain Ware Co., 67 New Montgomery St., San Francisco.
George H. Tay Company, Mission and Second Sts., San Francisco; 10th and Harrison Sts., Oakland.
Haines, Jones & Cadbury Co., 857 Folsom St., San Francisco.
- DUMB WAITERS**
Spencer Elevator Company, 166 7th St., San Francisco.
M. E. Hammond, Pacific Bldg., San Francisco
- ELECTRICAL CONTRACTORS**
Butte Electrical Equipment Company, 530 Folsom St., San Francisco.
Butte Electric & Manufacturing Co., 534 Folsom St., San Francisco.
Brown-Langlais Electrical Construction Co., 213 Minna St., San Francisco.
Central Electric Company, 185 Stevenson street, San Francisco.
NePage, McKenny Co., 589 Howard St., San Francisco.
Liberty Electric Company, 479 Sutter St., San Francisco.
Newbery Electrical Co., 413 Lick Bldg., San Francisco.
Pacific Fire Extinguisher Co., 424 Howard St., San Francisco.
Globe Electric Works, 1959 Mission St., San Francisco.
M. E. Ryan, Redwood City, Calif.
H. S. Tittle, 766 Folsom St., San Francisco.
Spencer Electric Co., 355 12th street, Oakland.
Spott Electrical Co., Sixteenth and Clay Sts., Oakland.
- ELECTRIC PLATE WARMER**
The Prometheus Electric Plate Warmer for residences, clubs, hotels, etc. Sold by M. E. Hammond, Pacific Bldg., San Francisco.
- ELECTRICAL SUPPLIES AND EQUIPMENT**
Garnett Young & Co., 612 Howard St., San Francisco.
Butte Electrical Equipment Co., 530 Folsom St., San Francisco.
Electric Outlet Co., Inc., 119 West 40th St., New York.
Safety Electric Company, 56-65 Columbia Square, San Francisco.
Drendell Electrical & Mfg. Co., 1345 Howard St., San Francisco.
R. J. Davis, District Sales Agent, Century A. C. Motors and Fans, 171 Second St., San Francisco.
Western Electric Safety Mfg. Co., Inc., 247 Minna street, San Francisco.
- ELEVATORS**
Otis Elevator Company, Stockton and North Point, San Francisco.
Spencer Elevator Company, 166 7th St., San Francisco.
- ELEVATOR EQUIPMENT**
Elevator Supplies Company, Inc., 186 Fifth St., San Francisco.

KEWANEE
GARBAGE BURNERS
AND
BOILERS

YEOMANS
BILGE PUMPS
EJECTORS
HOUSE PUMPS

OVERHEAD
CARRYING
SYSTEMS

CALIFORNIA HYDRAULIC ENGINEERING & SUPPLY CO., 80 Fremont St., S. F.

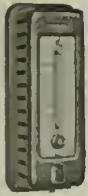

TEMPERATURE REGULATION

JOHNSON SERVICE COMPANY

(OF MILWAUKEE — ESTABLISHED 1885)

Manufacturers and Installers of **JOHNSON Heat Humidity Control**

For schools, residences, hospitals, banks, public buildings, also canneries and all kinds of industrial plants—Hot water tank regulators, air and water reducing valves.

Rialto Bldg., SAN FRANCISCO 605 Van Nuys Bldg., LOS ANGELES



ARCHITECTS' SPECIFICATION INDEX—Continued

ENGINEERS—CONSULTING, ELECTRICAL, MECHANICAL

Chas. T. Phillips, Pacific Bldg., San Francisco.
Hunter & Hudson, Rialto Bldg., San Francisco.

ELEVATOR DOOR HARDWARE

Richards-Wilcox Mfg. Co., Underwood Bldg., San Francisco.

FANS AND BLOWERS

Ideal Heating & Engineering Co., 192 Erie St., San Francisco.
John Ringins Co., Inc., 1267 Folsom street, San Francisco.

FENCES—WIRE

Standard Fence Construction Co., 245 Market St., San Francisco, and 310 12th St., Oakland.

FILLING STATION EQUIPMENT

S. F. Bowser & Co., Inc., 612 Howard St., San Francisco.
Wayne Oil Tank & Pump Co., 631 Howard St., San Francisco, 830 S. Los Angeles St., Los Angeles.

FIRE BRICK

Livermore Fire Brick Works, 604 Mission street, San Francisco.

FIRE ESCAPES

Palm Iron & Bridge Works, Sacramento.
Western Iron Works, 141 Beale St., San Francisco.
Golden Gate Iron Works, 1541 Howard St., San Francisco.

FIRE EXTINGUISHERS

American La France Fire Engine Co., Inc., 151 New Montgomery St., San Francisco; Los Angeles and Portland.

FIRE INSURANCE

Banks & Shippers Insurance Co., Insurance Exchange Bldg., San Francisco.

FIRE PROOFING

American Insulex Company, Berkeley Bank Bldg., Berkeley.

FIRE-PROOF DOORS

Forderer Cornice Works, 269 Potrero avenue, San Francisco.
U. S. Metal Products Co., 330 10th street, San Francisco.
Fire Protection Products Co., 3117 20th street, San Francisco.

FIRE SPRINKLERS—AUTOMATIC

Grinnell Company, 453 Mission St., San Francisco.
Pacific Fire Extinguisher Co., 424 Howard St., San Francisco.

FIRE RETARDING PAINT

The Paraffine Companies, Inc., 34 First St., San Francisco.

FIXTURES—BANK, OFFICE, STORE, ETC.

Home Manufacturing Company, 543 Brannan St., San Francisco.
The Fink & Schindler Co., 218 13th St., San Francisco.
Mullen Manufacturing Co., 64 Rausch St., San Francisco.
C. F. Weber & Co., 985 Market St., San Francisco, and 210 N. Main St., Los Angeles, Cal.

FLOOR TILE

Mangrum & Otter, 827 Mission St., San Francisco.

FLOOR VARNISH

Bass-Hueter and San Francisco Pioneer Varnish Works, 816 Mission St., San Francisco.
Fifteen for Floors, made by W. P. Fuller & Co., San Francisco.
Standard Varnish Works, Chicago, New York and San Francisco.
R. N. Nason & Co., San Francisco and Los Angeles.

FLOORS—HARDWOOD

Oak Flooring Manufacturers' Association of the United States, Ashland Block, Chicago, Ill.
Parrott & Co., 320 California St., San Francisco.
White Bros., Fifth and Brannan Sts., San Francisco.
Strable Hardwood Company, 511 First street, Oakland.

FLOORS—MASTIC

Hill, Hubbell & Company, No. 1 Drumm St., San Francisco.

FLOORS—DUST PROOF CEMENT

L. Sonneborn Co., United Materials Co., San Francisco agents.

FLUMES

California Corrugated Culvert Co., West Berkeley, Cal.

FLUSH VALVES

National Valve Company, 23-25 Minna St., San Francisco.

FRUIT DRYING MACHINERY

Ideal Heating & Engineering Co., 192 Erie St., San Francisco.

FUEL OIL SYSTEMS

Jas. A. Nelson, 517 Sixth St., San Francisco.
S. T. Johnson Co., 1337 Mission St., San Francisco.

FURNACES—WARM AIR

S. F. Bowser & Co., Inc., 612 Howard St., San Francisco.
Wayne Oil Tank & Pump Co., 631 Howard St., San Francisco.
Mangrum & Otter, 827 Mission St., San Francisco.
Montague Range and Furnace Co., 826 Mission St., San Francisco.

FURNITURE—BUILT-IN

Hoosier Kitchen Cabinet Store, Pacific Bldg., San Francisco.

FURNITURE—SCHOOL, CHURCH, OFFICE, HOUSE, ETC.

Home Manufacturing Company, 543 Brannan St., San Francisco.
C. F. Weber & Co., 985 Market St., San Francisco.
Rucker-Fuller Desk Co., 677 Mission St., San Francisco.
F. W. Wentworth & Co., 539 Market St., San Francisco.
W. & J. Sloane, 216-228 Sutter St., San Francisco.

GARAGE HARDWARE

The Stanley Works, New Britain, Conn., represented in San Francisco, Los Angeles, Seattle by John T. Rowntree, Inc.
Richards-Wilcox Mfg. Co., Aurora, Ill., and Underwood Bldg., San Francisco.

ROBERTSON PROCESS METAL FOR ROOFING AND SIDING

HH ROBERTSON CO

BUILDING PRODUCTS

FORMERLY ASBESTOS PROTECTED METAL COMPANY

Hobart Building, San Francisco

Phone Garfield 522

HOT WATER ELECTRICALLY

ALL YOU WANT ALL THE TIME THERM-ELECT WATER HEATER for APARTMENT HOUSES, RESIDENCES, ETC.

ELECTRIC SALES SERVICE COMPANY

2532 Sixth Street, BERKELEY

Phone Berkeley 3070

ARCHITECTS' SPECIFICATION INDEX—Continued

- GARBAGE CHUTES AND INCINERATORS**
Kerner Incinerator Co., 77 O'Farrell St., San Francisco.
California Hydraulic Engineering & Supply Co., 70-72 Fremont St., San Francisco.
- GAS STEAM RADIATORS—FUMELESS, ETC.**
Clow Gas Steam Radiators, F. A. Hamilton, Agent, 101 Rialto Bldg., San Francisco.
- GAS STEAM RADIATORS, ETC.—Continued.**
Ra-Do Fumeless Gas Radiators, manufactured and sold by Baird-Bailhache Co., 478 Sutter St., San Francisco.
- GLASS**
American Window Glass Co., represented by L. H. Butcher Co., 862 Mission St., San Francisco.
Cobbledick-Kibbe Glass Co., 175 Jessie St., San Francisco.
Fuller & Goepf, 32 Page St., San Francisco.
W. P. Fuller & Company, all principal Coast cities.
- GRADING, WRECKING, ETC.**
Dolan Wrecking & Construction Co., 1607 Market St., San Francisco.
- GRANITE**
California Granite Co., Gen. Contractors' Ass'n, San Francisco.
Raymond Granite Co., Potrero Ave. and Division St., San Francisco.
- GRAVEL AND SAND**
Coast Rock & Gravel Co., Call-Post Bldg., San Francisco.
Del Monte White Sand, sold by Del Monte Properties Co., Crocker Bldg., San Francisco.
- GYMNASIUM EQUIPMENT**
Ellery Arms Co., 583 Market St., San Francisco.
A. G. Spalding & Bros., 158 Geary St., San Francisco.
- HARDWALL PLASTER**
Henry Cowell Lime & Cement Co., San Francisco.
- HARDWARE**
Joost Bros., agents for Russell & Erwin hardware, 1053 Market St., San Francisco.
The Stanley Works, New Britain, Conn.; Coast sales offices, San Francisco, Los Angeles, and Seattle, Wash.
Corbin hardware, sold by Palace Hardware Co., 581 Market St., San Francisco.
Richards-Wilcox Mfg. Co., Aurora, Ill., Ewing-Lewis Co., 626 Underwood Bldg., San Francisco.
- HARDWOOD LUMBER—FLOORING, ETC.**
Dieckmann Hardwood Company, Beach and Taylor Sts., San Francisco. (See advertisement above.)
H. N. McNab, 2307 17th Ave., Oakland.
Parrott & Co., 320 California St., San Francisco.
White Bros., cor. Fifth and Brannan Sts., San Francisco.
Strable Hardwood Company, First street, near Broadway, Oakland.
- HEATERS—AUTOMATIC, GAS, ELECTRIC**
Electric Sales Service Co., mfrs. of Therm-elect Water Heater, West Berkeley.
- Pittsburg Water Heater Co., 478 Sutter St., San Francisco.
George H. Tay Company, Mission and Second Sts., San Francisco; 10th and Harrison Sts., Oakland.
Ra-Do Fumeless Gas Heater, sold by Baird-Bailhache Company, 478 Sutter St., San Francisco.
- HEATING AND VENTILATING CONTRACTOR'S, EQUIPMENT, ETC.**
Alex Coleman, 706 Ellis St., San Francisco.
C. A. Dunham Co., Sheldon Building, San Francisco.
Gilley-Schmid Company, 198 Otis St., San Francisco.
Hateley & Hateley, Mitau Bldg., Sacramento.
Knittle-Cashel Co., Inc., 1820 Ellis St., San Francisco.
General Boilers Co., 332 Monadnock Bldg., San Francisco.
Mangrum & Otter, 827-831 Mission St., San Francisco.
Moline Heat, Hobart Bldg., San Francisco.
James & Drucker, 450 Hayes St., San Francisco.
James A. Nelson, 517 Sixth St., San Francisco.
Ideal Heating & Engineering Co., 192 Erie St., San Francisco.
Illinois Engineering Co., 563 Pacific Bldg., San Francisco.
William F. Wilson Co., 328 Mason St., San Francisco.
Pacific Fire Extinguisher Co., 424 Howard St., San Francisco.
Scott Company, 243 Minna St., San Francisco.
Mechanical Engineering & Supply Co., 908 7th St., Sacramento.
George H. Tay Company, Mission and Second Sts., San Francisco; 10th and Harrison Sts., Oakland.
O. M. Simmons Co., 115 Mission St., San Francisco.
- HOLLOW TILE BLOCKS**
Cannon & Co., plant at Sacramento; office in Chronicle Bldg., San Francisco.
Gladding, McBean & Co., San Francisco, Los Angeles, Oakland and Sacramento.
Los Angeles Pressed Brick Co., Frost Bldg., Los Angeles.
California Brick Company, 604 Mission street, San Francisco.
Livermore Fire Brick Works, 604 Mission street, San Francisco.
- HOSPITAL FIXTURES**
Mott Company of California, 553 Mission St., San Francisco.
George H. Tay Company, Mission and Second Sts., San Francisco; 10th and Harrison Sts., Oakland.
- HOSPITAL SIGNAL SYSTEM**
Chicago Signal Co., represented by Garnett, Young & Co., 612 Howard St., San Francisco.
- HOTELS**
St. Francis Hotel, Powell, Geary and Post Sts., San Francisco.

"The Perfect Automatic Valve"

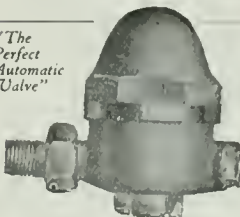

Haines Heating Systems

ASSURE

Heating Satisfaction

O. M. SIMMONS CO.

115 Mission St., San Francisco
Phone: Douglas 5497

CLARENCE E. MUSTO, Pres.

JOSEPH B. KEENAN, Vice-Pres.

GUIDO J. MUSTO, Sec'y & Treas.

JOSEPH MUSTO SONS-KEENAN CO.Phone Franklin
—6365—**MARBLE**OFFICE AND MILLS:
535-565 North Point St.,
SAN FRANCISCO, CAL.**ARCHITECTS' SPECIFICATION INDEX—Continued**

- INGOT IRON**
"Armco" brand, manufactured by American Rolling Mill Company, Middletown, Ohio, and 10th and Bryant streets, San Francisco.
- INSPECTIONS AND TESTS**
Robert W. Hunt & Co., 251 Kearny St., San Francisco.
- INSULATION**
American Insulux Company, Berkeley Bank building, Berkeley.
- INCINERATORS**
Kerner Incinerator Co., 77 O'Farrell St., San Francisco.
- INTERIOR DECORATORS**
Beach-Robinson Co., 239 Geary St., San Francisco.
Arthur Brown, 212 Foxcroft Bldg., San Francisco.
John Breuner Co., 281 Geary St., San Francisco.
Sonnenschein Bros., 470 Sutter St., San Francisco.
The Tormey Co., 1042 Larkin St., San Francisco.
Taylor Galleries, 1818 Harrison street, Oakland and San Francisco.
Freeman Art Shop, 386 Sutter St., San Francisco.
W. & J. Sloane, 216 Sutter St., San Francisco.
- KITCHEN CABINETS**
Hoosier Kitchen Cabinet Store (O. K. Brown, Mgr.), Pacific Bldg., San Francisco.
- LAMP POSTS, ELECTROLIERS, ETC.**
J. L. Mott Iron Works, 553 Mission St., San Francisco.
- LANDSCAPE GARDENERS**
MacRorie-McLaren Co., 141 Powell St., San Francisco.
- LATHING AND PLASTERING**
MacGruer & Simpson, Call-Post Bldg., San Francisco.
A. Knowles, Call-Post Bldg., San Francisco.
Jas. F. Smith, 273 Minna St., San Francisco.
- LATHING MATERIAL**
Pacific Materials Co., 525 Market St., San Francisco.
Truscon Steel Co., Tenth St., near Bryant, San Francisco.
- LIGHT, HEAT AND POWER**
Great Western Power Company, Stockton St., near Sutter, San Francisco.
- LIGHTING FIXTURES**
Roberts Mfg. Co., 663 Mission St., San Francisco.
Perfecite Manufacturing Co., Seattle, Wash.; San Francisco Representatives, Myers & Schwartz, 75 New Montgomery street, San Francisco; 1119 S. Los Angeles street, Los Angeles.
- LIME**
Henry Cowell Lime & Cement Co., 2 Market St., San Francisco.
- LINOLEUM**
D. N. & E. Walter & Co., 562 Mission St., San Francisco.
The Paraffine Companies, factory in Oakland; office, 34 First St., near Market, San Francisco.
W. & J. Sloane, 216-228 Sutter St., San Francisco.
- LUBRICATING OIL STORAGE TANKS AND PUMPS**
S. F. Bowser & Co., Inc., 612 Howard St., San Francisco
- LUMBER**
California Redwood Association, 216 Pine St., San Francisco.
Dudfield Lumber Co., Palo Alto, Cal.
Hart-Wood Lumber Co., Fifth and Berry Sts., San Francisco.
Pacific Manufacturing Company, San Francisco, Oakland and Santa Clara.
Pope & Talbot, foot of Third St., San Francisco.
Santa Fe Lumber Co., 16 California street, San Francisco.
Sunset Lumber Company, First and Oak Sts., Oakland.
- MAIL CHUTES**
American Mailing Device Corp., represented on Pacific Coast by Waterhouse-Wilcox Co., 523 Market St., San Francisco.
- MANTELS**
Mangrum & Otter, 827-831 Mission St., San Francisco.
California Brick Company, 604 Mission street, San Francisco.
- MANUAL TRAINING EQUIPMENT**
Richards-Wilcox Mfg. Co., Ewing-Lewis Co., 626 Underwood Bldg., San Francisco.
Smith-Booth-Usher Co., San Francisco and Los Angeles.
- MARBLE**
American Marble and Mosaic Co., 25 Columbus Square, San Francisco.
Joseph Musto Sons, Keenan Co., 535 N. Point St., San Francisco.
Vermont Marble Co., Coast branches, San Francisco, Portland and Tacoma.
- METAL DOORS AND WINDOWS**
Fire Protection Products Co., 3117 20th St., San Francisco.
Waterhouse-Wilcox Co., Inc., 523 Market St., San Francisco.
U. S. Metal Products Co., 330 Tenth St., San Francisco.
- METAL FURNITURE**
Forderer Cornice Works, 269 Potrero avenue, San Francisco.
- MILL WORK**
Dudfield Lumber Co., Palo Alto, Cal.
Pacific Manufacturing Company, San Francisco, Oakland and Santa Clara.
National Mill and Lumber Co., San Francisco and Oakland.
The Fink & Schindler Co., 218 13th St., San Francisco.
Frank Portman, 1619-20 Mission St., San Francisco.
Lannom Bros. Mfg. Co., 5th and Magnolia sts., Oakland.
- MOTORS AND FANS**
R. J. Davis, Dist. Sales Agent Century Motors and Fans, 171 Second St., San Francisco.

KNITTLE-CASHEL CO., Inc.

HEATING CONTRACTORS

STEAM HEATING
HOT WATER HEATINGVENTILATING
POWER PLANTSGENERAL PIPE WORK
REPAIRING

1820-22 Ellis Street, San Francisco

Phone West 964

ARCHITECTS' SPECIFICATION INDEX—Continued

OIL BURNERS

- Bunting Iron Works, 1215 First Nat. Bank bldg., San Francisco.
 Fess System Co., 220 Natoma St., San Francisco.
 S. T. Johnson Co., 1337 Mission St., San Francisco.
 T. P. Jarvis Manufacturing Co., 275 Connecticut St., San Francisco.
 G. E. Witt Co., 862 Howard St., San Francisco.

OIL STORAGE AND DISTRIBUTING STATIONS

- S. F. Bowser & Co., Inc., 612 Howard St., San Francisco.
 S. T. Johnson Co., 1337 Mission St., San Francisco.
 Wayne Oil Tank & Pump Co., 631 Howard St., San Francisco; 830 S. Los Angeles St., Los Angeles.

OFFICE EQUIPMENT

- C. F. Weber Co., 985 Market St., San Francisco.
 Rucker-Fuller Co., 677 Mission St., San Francisco.
 F. W. Wentworth & Co., 539 Market St., San Francisco.

ORNAMENTAL IRON AND BRONZE.

- California Artistic Metal and Wire Co., 349 Seventh St., San Francisco.
 Palm Iron & Bridge Works, Sacramento.
 C. J. Hillard Company, Inc., 19th and Minnesota Sts., San Francisco.
 Schrader Iron Works, Inc., 1247 Harrison St., San Francisco.

OVERHEAD CARRYING SYSTEMS

- California Hydraulic Engineering & Supply Co., 70-72 Fremont St., San Francisco.
 Richards-Wilcox Mfg. Co., Aurora, Ill., and Underwood Bldg., San Francisco.

PAINT FOR STEEL STRUCTURES, BRIDGES, ETC.

- The Paraffine Companies, Inc., 34 First St., San Francisco.
 Premier Graphite Paint and Pioneer Brand Red Lead, made by W. P. Fuller & Co., San Francisco.
 Hill, Hubbell & Company, No. 1 Drumm St., San Francisco.
 Wadsworth, Howland Co., makers of Bay State Brick and Cement Coating, Boston, Mass.
 Hambley & Son, Distributors in San Francisco and Los Angeles.

PAINTING, TINTING, ETC.

- I. R. Kissel, 1747 Sacramento St., San Francisco.
 D. Zelinsky & Sons, San Francisco and Los Angeles.
 The Tormey Co., 681 Geary St., San Francisco.
 Fick Bros., 475 Haight St., San Francisco.
 Pacific Painting and Roofing Co., Pacific building, San Francisco; and 388 12th street Oakland.

PAINTS, OILS, ETC.

- California Paint Company (see advertisement above).
 Magnor Bros., 414-424 Ninth St., San Francisco.
 Bass-Hueter Paint Co., Mission, near Fourth St., San Francisco and all principal coast cities.
 R. N. Nason & Company, San Francisco, Los Angeles, Portland and Seattle.
 Ronfic Company, Pacific building, San Francisco; and 388 12th street, Oakland.
 W. P. Fuller & Co., all principal Coast cities.
 "Satinette," Standard Varnish Works, 55 Stevenson St., San Francisco.
 Palace Hardware Co., 581 Market St., San Francisco.

PANELS AND VENEER

- White Bros., Fifth and Brannan Sts., San Francisco.

PARTITIONS—FOLDING AND ROLLING

- J. G. Wilson Corporation, 600 Metropolitan Bldg., Los Angeles; Waterhouse-Wilcox Co., Underwood Bldg., San Francisco.

PENCILS

- Eberhard Faber, Monadnock Bldg., San Francisco.

PIPE—STEEL AND WROUGHT IRON

- Western Pipe & Steel Co., 444 Market St., San Francisco; 1758 N. Broadway, Los Angeles.
 George H. Tay Company, Mission and Second Sts., San Francisco; 10th and Harrison Sts., Oakland.

PLUMBING GROUND EQUIPMENT

- A. G. Spalding & Bros., 158 Geary St., San Francisco.

PLUMBING CONTRACTORS

- Alex Coleman, 706 Ellis St., San Francisco.
 Gilley-Schmid Company, 198 Otis street, San Francisco.
 Hately & Hately, Mitau Bldg., Sacramento.
 Scott Co., Inc., 243 Minna St., San Francisco.
 Wm. F. Wilson Co., 328 Mason St., San Francisco.

PLUMBING FIXTURES, MATERIALS, ETC.

- All-In-One Company, Ochsner bldg., Sacramento.
 California Steam & Plumbing Supply Co., 671 Fifth St., San Francisco.
 Crane Co., San Francisco, Oakland, Los Angeles.
 Gilley-Schmid Company, 198 Otis St., San Francisco.
 Haines, Jones & Cadbury Co., 857 Folsom St., San Francisco.
 H. Mueller Manufacturing Company, 635 Mission St., San Francisco.
 Holbrook, Merrill & Stetson, 64 Sutter St., San Francisco.
 J. L. Mott Iron Works, D. H. Gulick, selling agent, 553 Mission St., San Francisco.
 National Valve Company, 23-25 Minna St., San Francisco.
 Pacific Sanitary Manufacturing Co., 67 New Montgomery St., San Francisco.
 George H. Tay Company, Mission and Second Sts., San Francisco; 10th and Harrison Sts., Oakland.
 Standard Metals Mfg. Co., 1300 N. Main st., Los Angeles.
 West Coast Porcelain Manufacturers, Rialto building, San Francisco.
 Wm. F. Wilson Co., 328 Mason St., San Francisco.

POLES AND PILING

- Sante Fe Lumber Co., 16 California street, San Francisco.

POWER PLANTS

- Knittle-Cashel Co., Inc., 1820 Ellis St., San Francisco.

POWER TRANSMITTING MACHINERY

- Meese & Gottfried, San Francisco, Los Angeles, Portland, Ore., and Seattle, Wash.

PUMPS

- Chicago Pump Co., represented by Garnett Young & Co., 612 Howard St., San Francisco.
 California Hydraulic Engineering & Supply Co., 70 Fremont St., San Francisco.
 Simonds Machinery Co., 117 New Montgomery St., San Francisco.
 Ocean Shore Iron Works, 558 Eighth St., San Francisco.
 Pacific Pump & Supply Company, 851-853 Folsom St., San Francisco.
 George H. Tay Company, Mission and Second Sts., San Francisco; 10th and Harrison Sts., Oakland.

PUMPS—HAND OR POWER, FOR OIL AND GASOLINE

- S. F. Bowser & Co., Inc., 612 Howard St., San Francisco.
 S. T. Johnson Co., 1337 Mission St., San Francisco.
 Wayne Oil Tank & Pump Co., 631 Howard St., San Francisco; 830 S. Los Angeles St., Los Angeles.
 George H. Tay Company, Mission and Second Sts., San Francisco; 10th and Harrison Sts., Oakland.



Yards:
Tracy - Brentwood
Patterson - Newman
California

Phones:
Kearny 2073 - 2074

SANTA FE LUMBER CO.

A. J. RUSSELL, Mgr.

Wholesale and Retail

LUMBER

POLES AND PILING
OIL RIG AND SHIP TIMBERS
SAGINAW SPECIAL SHINGLES

FENCE POSTS
SIMPLEX SILOS
PAPEC ENSILAGE CUTTERS

16 California Street

San Francisco, Calif.

from tree to Consumer

Pine and Redwood Lumber

SASH DOORS AND MILL WORK

SUNSET LUMBER COMPANY

MANUFACTURERS — WHOLESALE AND RETAIL

Main Office and Yards:

FIRST AND OAK STREETS, OAKLAND

Phone Oakland 1820

POPE & TALBOT

Manufacturers, Exporters and Dealers in

Lumber, Timber, Piles, Spars, etc.

Office, Yards and Planing Mills

859-869 THIRD ST., SAN FRANCISCO, CAL.

Mills, Port Gamble, Port Ludlow and Utsalady, Washington

PACIFIC MANUFACTURING COMPANY

MILLWORK, SASH AND DOORS

Hardwood Interior Trim a Specialty

Main Office:

SANTA CLARA, CALIF.

SAN FRANCISCO, 177 Stevenson Street
OAKLAND, 1001 Franklin Street

LOS ANGELES, 908 Washington Building
SAN JOSE, 16 North First Street

ARCHITECTS' SPECIFICATION INDEX—Continued

RADIATOR TRAPS

C. A. Dunham Co., Sheldon Bldg., San Francisco.

REINFORCING STEEL

Edward L. Soule, Rialto Building, San Francisco.
Gunn, Carle & Co., Inc., 444 Market street, San Francisco.

Pacific Coast Steel Co., Rialto Building, San Francisco.

Truscon Steel Co., 527 10th St., San Francisco.

REFRIGERATORS

McCray Refrigerator Company, San Francisco office, 765 Mission street.

REVERSIBLE WINDOWS

Janser Window Company, 157 Minna St., San Francisco.

ROOFING CONTRACTORS

Bender Roofing Company, Monadnock Bldg., San Francisco.

National Roofing Company, Pacific Roofing Co., C. G. Williams, A. K. Goodmundson, 2140 San Pablo ave., Oakland.

ROOFING AND ROOFING MATERIALS

"Malthoid" and "Ruberoid," manufactured by Paraffine Companies, Inc., San Francisco.

United Materials Co., Crossley Bldg., San Francisco.

H. H. Robertson Co., Hobart Bldg., San Francisco.

California Brick Company, 604 Mission street, San Francisco.

RUBBER TILING

New York Belting and Packing Company, 518 Mission St., San Francisco.

SAFETY TREADS

Pacific Materials Co., 525 Market St., San Francisco.

SAND

Del Monte White Sand, Del Monte Properties Co., 401 Crocker Bldg., San Francisco.

SASH CORD

Samson Spot Sash Cord, John T. Rowntree, Pacific Coast Agent, San Francisco and Los Angeles.

SCENIC PAINTING—DROP CURTAINS, ETC.

The Edwin H. Flagg Scenic Co., 1638 Long Beach Ave., Los Angeles.

SCHOOL FURNITURE AND SUPPLIES

C. F. Weber & Co., 985 Market St., San Francisco; 512 S. Broadway, Los Angeles.

Rucker-Fuller Desk Company, 677 Mission St., San Francisco.

SHEATHING AND SOUND DEADENING

Samuel Cabot Mfg. Co., Boston, Mass., agencies in San Francisco, Oakland, Los Angeles, Portland, Tacoma and Spokane.

The Paraffine Companies, Inc., 34 First St., San Francisco.

SHEET METAL WORK

Forderer Cornice Works, 269 Potrero ave., San Francisco.

U. S. Metal Products Co., 330 10th street, San Francisco.

Fire Protection Products Co., 3117 20th street, San Francisco.

SHINGLE STAINS

Bass-Hueter Paint Company, all principal Coast cities.

Cabot's Creosote Stains, sold by Pacific Building Materials Co., 525 Market St., San Francisco.

Fuller's Pioneer Shingle Stains, made by W. P. Fuller & Co., San Francisco.

Argonaut Shingle Stains. The Glidden Co., 123 Hooper St., San Francisco.

SHINGLES—STONE

McClenahan Products Co., Inc., 670 Howard St., San Francisco.

SINKS—COMPOSITION

Petrium Sanitary Sink Co., Fifth and Page Sts., Berkeley.

STATIONERY AND SUPPLIES

Schwabacher-Frey Stationery Co., 609 Market St., San Francisco.

H. S. Crocker Co., 565 Market street, San Francisco.

STEEL HEATING BOILERS

California Hydraulic Engineering & Supply Co., 70-72 Fremont St., San Francisco.

General Boilers Co., 332 Monadnock Bldg., San Francisco.

STEEL TANKS, PIPE, ETC.

Ocean Shore Iron Works, 558 Eighth St., San Francisco.

S. T. Johnson Co., 1337 Mission St., San Francisco.

STEEL AND IRON—STRUCTURAL

Central Iron Works, 621 Florida St., San Francisco.

Mortenson Construction Co., 19th and Indiana Sts., San Francisco.

Pacific Rolling Mills, 17th and Mississippi Sts., San Francisco.

Palm Iron & Bridge Works, Sacramento.

U. S. Steel Products Co., Rialto Bldg., San Francisco.

Schrader Iron Works, Inc., 1247 Harrison St., San Francisco.

Western Iron Works, 141 Beale St., San Francisco.

STEEL PRESERVATIVES

Hill, Hubbell & Company, No. 1 Drumm St., San Francisco.

STEEL ROLLING DOORS

Pacific Building Materials Co., Underwood Bldg., San Francisco.

J. G. Wilson Corporation, 600 Metropolitan Bldg., Los Angeles.

STEEL SASH

Bayley-Springfield solid steel sash, sold by Pacific Materials Co., 525 Market St., San Francisco.

"Fenestra," solid steel sash, manufactured by Detroit Steel Products Company, Detroit, Mich. Direct factory sales office, Foxcroft Bldg., San Francisco.

U. S. Metal Products Company, 330 Tenth St., San Francisco.

Truscon Steel Company, 527 Tenth street, San Francisco.

STORE FRONTS

The Kawncer Manufacturing Company, West Berkeley, California.

Zouri Safety Sash Bars—Cobbledick-Kibbe Glass Company, 175 Jessie St., San Francisco.

STUDDING—FIREPROOF STEEL

Steel Studding Company, 1216 Folsom St., San Francisco.

SUMP AND BILGE PUMPS

California Hydraulic Engineering & Supply Co., 70-72 Fremont St., San Francisco.

MOLINE HEAT

Hobart Building

San Francisco

TELEPHONE SUTTER 3818

ARCHITECTS' SPECIFICATION INDEX—Continued

SWITCHES

Wemco Safety Switch, manufactured and sold by W. E. Mushet Co., 502 Mission St., San Francisco.

Western Electric Safety Switch Co., Inc., 247 Minna street, San Francisco.

TELEPHONE AND ELECTRIC EQUIPMENT

Direct Line Telephone Co., 320 Market street, San Francisco.

THEATER AND OPERA CHAIRS

C. F. Weber & Co., 365 Market street, San Francisco.

Rucker-Fuller Desk Co., 677 Mission street, San Francisco.

THERMOSTATS FOR HEAT REGULATION

Johnson Service, Rialto Bldg., San Francisco.

TILES, MOSAICS, MANTELS, ETC.

Mangrum & Otter, 827-831 Mission street, San Francisco.

TILE FOR ROOFS

Cannon & Co., Sacramento; and 77 O'Farrell St., San Francisco.

California Brick Company, 604 Mission street, San Francisco.

Gladding, McBean & Co., Crocker Bldg., San Francisco.

United Materials Co., Sharon Bldg., San Francisco.

TRANSMISSION MACHINERY

Meese & Gottfried Co., San Francisco, Los Angeles and Portland.

VACUUM CLEANERS

United Electric Company, Canton, Ohio, manufacturers of Tucc Cleaners, sold in California by San Francisco Compressed Air Cleaning Co., Stockton and Sutter Sts., San Francisco

VALVES—PIPES AND FITTINGS

California Steam & Plumbing Supply Co., 671 Fifth St., San Francisco.

Crane Radiator Valves, manufactured by Crane Co., Second and Brannan Sts., San Francisco.

National Valve Company, 23-25 Minna St., San Francisco.

Grinnell Co., 453 Mission St., San Francisco.

O. M. Simmons Co., 115 Mission St., San Francisco.

H. Mueller Mfg. Co., 635 Mission street, San Francisco.

W. E. Mushet Co., 502 Mission St., San Francisco

George H. Tay Company, Mission and Second streets, San Francisco; 10th and Harrison streets, Oakland.

Shroeder Direct Flush Valves, mfrd. by Standard Metals Mfg. Co., 1300 N. Main street, Los Angeles.

VALVE PACKING

N. H. Cook Belting Co., 317 Howard St., San Francisco.

Everlasting Blow-off Valves. General Machinery and Supply Co., 39 Stevenson street, San Francisco.

VARNISHES

Bass-Hueter Paint Company, Mission, near 4th street, San Francisco, and all principal coast cities.

California Paint Company, 1797 Twelfth St., Oakland.

W. P. Fuller Co., all principal Coast cities.

R. N. Nason & Co., San Francisco, Los Angeles, Portland and Seattle.

Standard Varnish Works, 55 Stevenson St., San Francisco.

VENETIAN BLINDS, AWNINGS, ETC.

C. F. Weber & Co., 985 Market St., San Francisco.

Western Blind & Screen Co., 2702 Long Beach Ave., Los Angeles.

VITREOUS CHINAWARE

Pacific Porcelain Ware Company, 67 New Montgomery St., San Francisco.

West Coast Porcelain Manufacturers, Rialto Building, San Francisco.

WALL BEDS, SEATS, ETC.

Marshall & Stearns Co., 1154 Phelan Bldg., San Francisco.

WALL BOARD

"Amiwd" Wall Board, manufactured by The Paraffine Companies, Inc., 34 First St., San Francisco.

WALL PAINT

Nason's Opaque Flat Finish, manufactured by R. N. Nason & Co., San Francisco, Portland and Los Angeles.

San-A-Cote and Vel-va-Cote, manufactured by the Brininstool Co., Los Angeles.

WALL PAPER AND DRAPERIES

Arthur Brown, Foxcroft Bldg., San Francisco.

Beach-Robinson Co., 239 Geary St., San Francisco.

The Torney Co., 681 Geary St., San Francisco.

W. & J. Sloane, 216-228 Sutter St., San Francisco.

Uhl Bros., San Francisco.

WATERPROOFING FOR CONCRETE, BRICK, ETC.

Armorite Damp Resisting Paint, made by W. P. Fuller & Co., San Francisco.

Bay State Brick & Cement Coating, manufactured by Wadsworth, Howland Co., Boston; Hambley & Son., Distributors for Northern and Southern California.

Gunn, Carle & Co., Inc., "Hydrate," 444 Market street, San Francisco.

Imperial Waterproofing, manfrd. by Brooks & Doerr, Reed Baxter, agent, Merchants National Bank Bldg., San Francisco.

Pacific Materials Co., 525 Market St., San Francisco.

Samuel Cabot Mfg. Co., Boston, Mass., agencies in San Francisco, Oakland, Los Angeles, Portland, Tacoma and Spokane.

WATER SUPPLY SYSTEMS

Kewanee Water Supply System—Simonds Machinery Co., agents, 117 New Montgomery St., San Francisco.

Pacific Pump & Supply Company, 851-853 Folsom St., San Francisco.

Smith-Booth-Usher Co., San Francisco and Los Angeles.

Baird-Bailhache Co., 478 Sutter street, San Francisco.

WHEELBARROWS—STEEL

Western Iron Works, Beale and Main Sts., San Francisco.

WHITE ENAMEL

"Gold Seal" manufactured and sold by Bass-Hueter Paint Co. All principal Coast cities.

"Silkenwhite," made by W. P. Fuller & Co., San Francisco.

"Satinette," Standard Varnish Works, 55 Stevenson St., San Francisco.

WINDOW SHADES

W. & J. Sloane, 216-228 Sutter St., San Francisco.

WINDOW SASH CORD

Sampson Spot Cord, John T. Rowntree, Pacific Coast agents, San Francisco and Los Angeles

WINDOWS, REVERSIBLE, CASEMENT, ETC.

Hauser Window Co., 157 Minna St., San Francisco.

The Kawneer Company, West Berkeley, California. (Simplex Fixtures.)

J. G. Wilson Corporation, 600 Metropolitan Bldg., Los Angeles; Waterhouse-Wilcox Co., Underwood Bldg., San Francisco.

WIRE FENCE

Standard Fence Co., 245 Market street, San Francisco; and 310 12th street, Oakland.

WOOD MANTELS

Fink & Schindler, 218 13th St., San Francisco.

Mangrum & Otter, 827 Mission St., San Francisco.

W. E. JOHNSTON

V. A. ANDERSON

Life Insurance Engineers

Submit your INSURANCE PROBLEMS to us.

210 Crocker Building, San Francisco

Phone Kearny 4048

MOTT PLUMBING FIXTURES

Architects and their clients are invited to visit our Showrooms, 553-555 Mission Street, San Francisco; D. H. Gulick, Sales Agent. Los Angeles Office, 1001 Central Building; J. R. Mayhew, Sales Agent.

Mott Company of California

MUELLER — BRASS GOODS

Recognized as the Standard of excellence in plumbing. It pays to use them, and other Mueller Brass Goods. *The first cost is practically their last cost.*

H. Mueller Mfg. Co.

635 MISSION STREET, SAN FRANCISCO, CAL.

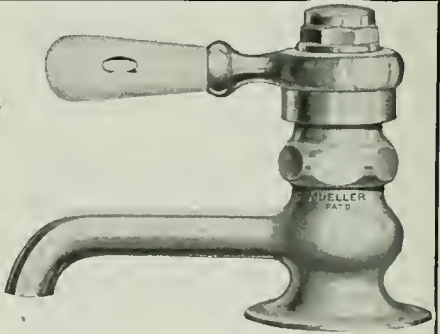

STORM KING and AMERICAN WARM AIR FURNACES

FURNACE FITTINGS AND REPAIRS

Montague Range & Furnace Company

327-329 JESSIE STREET

Phone Garfield 1422

826-830 MISSION STREET

SAN FRANCISCO, CALIF.

**DON'T NEGLECT YOUR HEATING SYSTEM.
THE BEST IS NONE TOO GOOD!**

All kinds of Galvanized Iron Work — Furnaces, Pipes, Ventilators — Sheet Metal for Planing Mills, Fruit Dryers, Rice Mills. Kitchen Equipment, including Steam Tables, Sinks, Canopies, Urn Stands, Etc.

JAMES A. NELSON

Heating and Ventilating Contractor

Phone, Garfield 1959

517-519 SIXTH ST., SAN FRANCISCO



Colusa Grammar School — Mr. J. S. Gould, Architect

All educated men are peers — Confucius

EVERY community has well defined marks of progress or retrogression. School buildings form an unswerving standard for comparison.

COLUSA has not alone established her right to be called progressive, but she has insured her future. The leaders of the Colusa of tomorrow are today mastering the three Rs (and more) in this splendidly-modern school.

ATTRACTIVE-exterior, inviting-interior, — this Colusa Grammar School is rendering an unmeasurable service to the community. No small part of the appeal of this splendid structure is due FULLER PRODUCTS, which were used exclusively upon this educational plant.

W. P. FULLER & CO.

"Since '49"

Manufacturers

PAINTS

ENAMELS

VARNISHES

San Francisco
Oakland
Sacramento
Stockton

Los Angeles
San Diego
Hollywood
Pasadena

Long Beach
Santa Monica
Portland
Tacoma

Seattle
Spokane
Boise
Salt Lake

CHICAGO

Condensation Pumps
Sewage Ejectors
Bilge Pumps

PUMP COMPANY

Garnett Young and Company

Pacific Coast Sales Engineers

612 Howard Street, San Francisco

SEATTLE

LOS ANGELES

PORTLAND



Pebble Beach Lodge, Monterey Co. Lewis P. Hobart, Architect

The White Cement Finish is given added Beauty
by the use of

DEL MONTE WHITE SAND

DEL MONTE PROPERTIES CO. 401 Crocker Bldg., San Francisco

Phone Sutter 6130

OAK FLOORS

(For Everlasting Economy)

BEWARE of Substitution

Insist on *American Oak Flooring*

SOME dealers and contractors on the coast have been shortsighted enough to substitute Japanese Oak Flooring in place of American Oak Flooring.

American Oak Flooring is so superior in color, strength and finish that there is really no comparison—the only inducement to use Japanese Oak Flooring being the lower price.

There have been many cases where dealers or contractors had to tear up Japanese Oak Flooring when property owners rejected it—a costly experience.

Japanese Oak Flooring is made from matured timber. It lacks the strength of the American product, besides being liable to take a spotted finish, due to the presence of soft boards.

To safeguard your reputation as well as the interests of your clients, we advise you to watch closely all jobs where you specify or recommend Oak Flooring. Be sure that the Oak Flooring used bears this trade-mark—stamped on every stick.

It not only identifies American-grown Oak Flooring, but denotes that the Oak Flooring in question has been inspected and passed by the independent inspectors of this Association through every phase of air seasoning, kiln drying, milling and grading.

Write for our free literature. It will be of interest and value to you in your professional practice.



See page 389, Sweet's Catalogue, for specifications of various grades.



OAK FLOORING MFRS. ASSN.

1036 ASHLAND BLOCK, CHICAGO, ILLINOIS



San - a - Cote

(GLOSS—Can be Scrubbed)

AN INTERIOR WALL FINISH

For bath rooms, kitchens, hospitals, schools, office and public buildings. Ask dealers, owners, architects and contractors about this durable, sanitary, washable, economical wall covering. Brininstool makes a paint for every purpose, and every can purposely good

THE BRININSTOOL CO., LOS ANGELES

COLOR GRINDERS AND PAINT MANUFACTURERS

Distributors—The Brininstool Co., 1174 Phelan Bldg., San Francisco, Cal.; The Brininstool Co., 222 Abington Bldg., Portland, Ore.; Schutz Paint Co., Fresno, Cal.; Schneider, Chappell & Jones, Sacramento, Cal.; Salt Lake Glass & Paint Co., Salt Lake City, Utah; Griffin Paint Co., Ogden, Utah; Campbell Hardware Co., First and Madison Sts., Seattle, Wash.; Imperial Valley Hardware Co., El Centro, Calexico, Imperial, Brawley, Seeley, Cal.; Spokane Hardware Co., Spokane, Wash.; Continental Paint Company, 328 South First St., San Jose, Cal.; Los Angeles Wall-paper & Paint Co., 525 So. Main St., Los Angeles, Cal.; H. A. Berger, 3838 13th St., San Diego, Cal.; H. L. Christian, Blythe, Cal.; Ezra Thayer, Phoenix, Ariz.; Miami Lumber & Supply Co., Miami, Ariz.

RELIANCE

BALL BEARING DOOR HANGERS

To get as near perfection as possible, use

RELIANCE "HANGERS" and "Reliance-Grant" Controllers

These insure fast service, practically noiseless and slamless doors.

Reliance-Grant Elevator Equipment Corp'n

PARK AVENUE AND 40TH STREET, NEW YORK

PACIFIC COAST AGENTS

Waterhouse-Wilcox Co.	-	San Francisco and Los Angeles, Cal.
Columbia Wire & Iron Works	-	Portland, Ore.
D. E. Fryer & Company	-	Seattle, Spokane, Tacoma, Wash. and Great Falls, Mont.

Insulex

This new heat insulation not only excels in durability and efficiency as a steam pipe covering but is especially adaptable to refrigeration practice.

AMERICAN INSULEX COMPANY

204 BERKELEY BANK BUILDING, BERKELEY
Phone Berkeley 641



'Villa Rosa,' the home of Mr. S. Z. Pili at Woodmont, Conn. Messrs. Brown & Von Beren of New Haven, Architects; cast stone work furnished by The Decorative Stone Co., New Haven.

Stucco and Ornaments of Medusa White Cement

This stately home demonstrates afresh the broad possibilities of Medusa Stainless White Cement. The residence itself is of stucco. The outer coat is of Medusa Stainless White, mixed with white sand. The balustrades, piers and decorative work are of cast concrete, composed of Medusa Stainless White Cement and aggregates. The color-values of Medusa Stainless White are permanent. Work may be made moisture-tight, without affecting either color or setting, by adding Medusa Waterproofing to the cement while mixing—approximately 8 pounds per barrel. To assure most accurate results, specify "Medusa Stainless White Cement—Waterproofed." This product consists of cement and waterproofing, ground together in correct proportions during the course of manufacture.

The "Medusa Review" shows various applications of cement in construction work of many kinds and contains other valuable data. Published every other month. Shall we put you on the complimentary list?



Interesting booklets gladly sent on request. The Sandusky Cement Co., Dept. P, Cleveland, Ohio. Manufacturers of Medusa Stainless White Cement plain or waterproofed and Medusa Waterproofing powder or paste.

PACIFIC COAST DISTRIBUTORS—Pacific Materials Co., San Francisco, Cal. Riverside Portland Cement Co., Los Angeles, Cal. A. McMillan & Company, Portland, Ore. Galbraith & Company, Seattle, Wash.

MEDUSA

Stainless White Cement



CANNON & CO.

Clay Products

Denison Interlocking Tile

Face Brick

Hollow Tile

Roof and Floor Tile

OFFICE:

Building Material Exhibit, 77 O'Farrell St., San Francisco

Telephone Sutter 5333

Factory and General Offices:

Sacramento, California

GENERAL BOILERS COMPANY

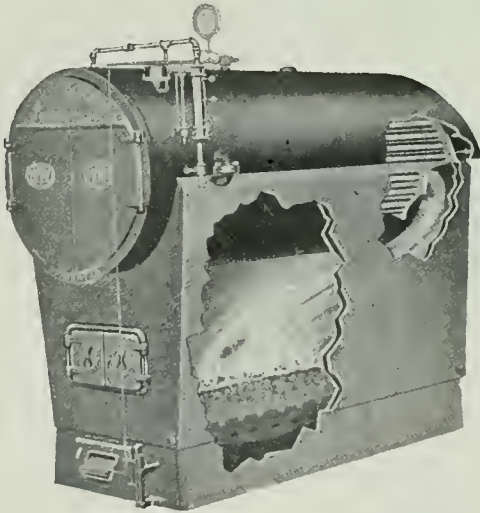

General Office and Plant:
WAUKEGAN, ILLS.

Manufacturers of

“PACIFIC”

STEEL HEATING BOILERS

AND

CIRCULATING TANKS

DEPARTMENT OF SALES:

322 MONADNOCK BUILDING, SAN FRANCISCO.

Telephone Sutter 4665



A New Type of Fireplace Equipment Making the Fireplace Usful as Well as Ornamental

This new fireplace fire combines architectural distinction with the highest radiating efficiency known. An achievement in house heating more wonderful than anything you have ever seen.

Directs the Heat Rays Like Sun Rays

The Humphrey Radiantfire is a gas fire, but with none of the shortcomings of the gas logs or asbestos front. It positively gives off no odor. Complete and perfect combustion which is possible in a Radiantfire has eliminated odor.

A small ventilating flue is all that is required to produce a perfectly ideal heat.

Numerous designs and finishes making it adaptable to all styles of architecture and character of decoration. A special architectural catalog showing various types and sizes and specifications for installing the simple ventilating flue will be sent to any interested architect.

Ask Us About Our Special Club Heater

The General Gas Light Company
New York Kalamazoo San Francisco

The HUMPHEY

Radiantfire

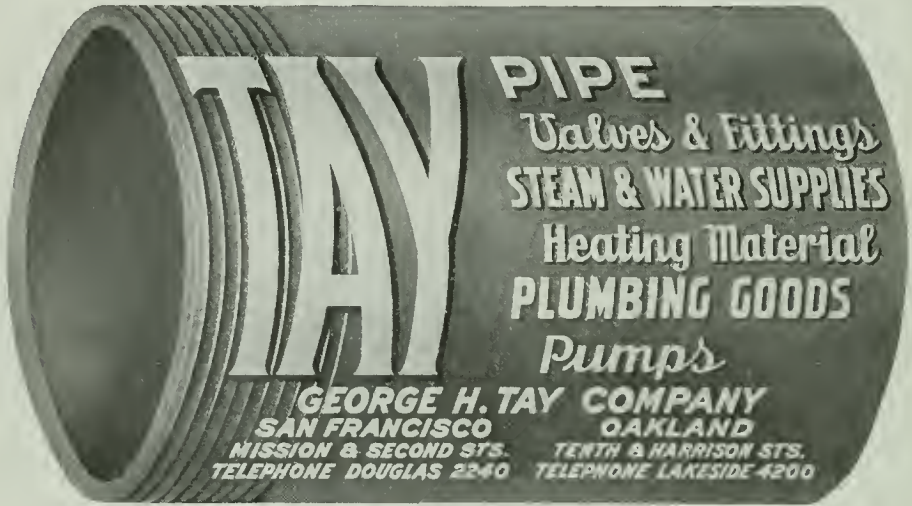

Ford

Whether for commercial purposes or pleasure, the Ford car will answer any requirement. It has proven its worth in every field of endeavor.

For eighteen years we have catered to the wants of the Ford buying public.

We can offer you the benefits of that long experience by giving you the acme of service through our coastwise organization.

William L. Hughson Co.

Since 1903

Geary at Van Ness, San Francisco
Prospect 607



Seattle

Portland

Oakland

Los Angeles

San Diego

THE HOME of BYBAMOPA WARE

You are cordially invited to visit the

**FREEMAN
ART SHOP**

Where there is displayed only the unusual and exclusive things in Lamp Shades, Mirrors, Candle Sticks, Candles, Book Ends, Oriental Rugs, Pottery, Bronzes, Solid Mahogany Furniture, Oil Paintings, Pastels, Fine Prints, Greeting Cards, Picture Framing.

386 SUTTER STREET, at Stockton

Interior Decorators

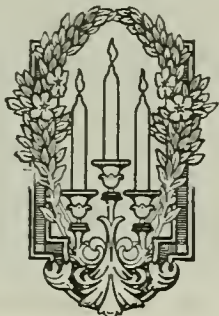

Beach-Robinson Co.

Decorators and Furnishers

Carpets

Draperies

Furniture

Rugs

Wall Paper

Ranson E. Beach

230 Geary Street, 3d Floor

Union Square

Phone, Sutter 580

San Francisco, Cal.



ADD CHEER and COMFORT

to the Home by having a

WELL DESIGNED INTERIOR

Before Completing Your Plans, CONSULT

SONNENSCHN BROS.

INTERIOR DECORATORS

Furniture and Draperies Made to Order

• Factory

718 NATOMA ST., Phone Market 1145

Show and Salesroom

470 SUTTER ST., Phone Kearny 2051



TAYLOR GALLERIES

Artistic Interiors

SPECIAL FURNITURE DRAPES - WALL PAPER

1818 Harrison St., near 19th, Oakland, Calif.

Phone Lakeside 3107

The GOLD MEDAL MAIL CHUTE



INSTALLED IN
THE NEW
SAN FRANCISCO
CITY HALL
AND THE
WHITE MARBLE
MERRITT
BUILDING,
LOS ANGELES

Given highest award at
Panama - Pacific Interna-
tional Exposition, 1915.

Waterhouse-Wilcox Co.

California
Representatives

523 Market Street
SAN FRANCISCO

331 E. 4th Street.
LOS ANGELES

F. T. CROWE & CO.
Seattle, Wash.

THE J. McCracken Co.
Portland, Oregon

**American Mailing
Device
Corporation**

EASY TO LAY
Great quantities of Clinton Electrically Welded Fabric can be laid in a very short time with absolute assurance that every strand of wire is in its proper position. It eliminates all the cost and trouble of spacing and wiring loose rods.

L. A. NORRIS COMPANY
110 Townsend St., San Francisco
Phone Kearny 5375

CLINTON
Electrically Welded Wire Fabric

MCCRAY REFRIGERATORS FOR ALL PURPOSES

It is our particular desire to impress the Architects of America with the fact that McCray builds refrigerators for all purposes. Thousands of fine residences, hotels, clubs, restaurants, factory cafeterias, hospitals, stores and markets depend on McCray for efficient, economical refrigerator service.

MCCRAY REFRIGERATOR CO.
765 Mission Street, San Francisco, Calif.
Home Office and Factory
Kendallville, Ind.

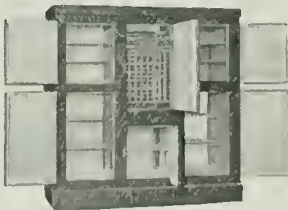

YOU KNOW that a building
should be watertight and
WE KNOW that it can be
made so with

IMPERIAL WATERPROOFING

LOOK FOR  THE LABEL

If your building is leaking through the walls or around the windows, or if the Basement walls are wet below ground — call up SUTTER 978.

IMPERIAL WATERPROOFING is manufactured by BROOKS & DOERR, 460 7th St., San Francisco

WATEREX REED BAXTER
DISTRIBUTOR

1002-04 Merchants National Bank Building,
Phone Sutter 978
SAN FRANCISCO, CAL.
3419 Broadway, OAKLAND, CAL.

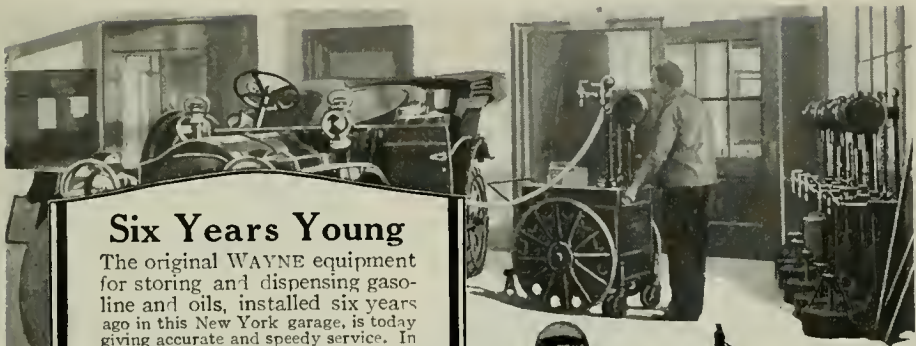

Six Years Young

The original WAYNE equipment for storing and dispensing gasoline and oils, installed six years ago in this New York garage, is today giving accurate and speedy service. In Wayne pumps the delicate adjustment essential for accuracy is combined with a durability that assures satisfaction for years and years.

There is a Wayne System for every need of the public garage. The service of Wayne engineers in advising and planning is yours without cost or obligation.

Wayne Oil Tank & Pump Co.
746 Canal St., Ft. Wayne, Ind.

San Francisco Office
631-633 Howard St.
Phone Garfield 1350

Los Angeles Office
830 S. Las Angeles St.
Phone Main 1600

REG. U. S.
Wayne
TRADE MARK
Liquid Storage Systems



Cut
No. 280
One-gallon
gasoline

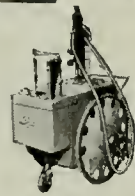

Cut
No. 230
For Gas
and Oil

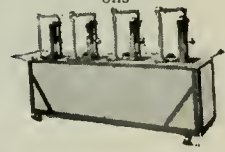

Cut
No. 200
Lubricating
oils

Pitcher Door Hangers



HUMPHREY APARTMENTS, SAN FRANCISCO
C. A. MEUSSDORFFER, Architect
Equipped with PITCHER HANGERS.

*Give Service
Satisfaction*

*Are Dependable
Durable and
Economical*

No extra thickness of wall required. Installed in 5½ inch partitions. Specify sliding doors in place of swinging doors.

Manufactured by

**National Mill and
Lumber Company**

 Kearny
3580

318 Market Street
SAN FRANCISCO



The Psychologist says—

“A drawing pencil is like a business which depends for its success on credit from the banks, or a man building character.”

“It must have years of excellent performance behind it and be known for constancy, honesty and reliability.

“I have found all of these qualities in the VAN DYKE.”

Ask for VAN DYKE by name at your stationers!

VAN DYKE DRAWING PENCILS

The Lead that Leads



Samples of any of the 16 degrees (6B softest to 8H hardest) of the “VAN DYKE” pencils, and booklet entitled “Eberhard Faber Pencils How They Are Made” will be sent upon request on your business stationery addressed to us at Monadnock Building, San Francisco, California.

EBERHARD FABER

“The Oldest Pencil Factory in America”

NEW YORK

When writing to Advertisers please mention this magazine.

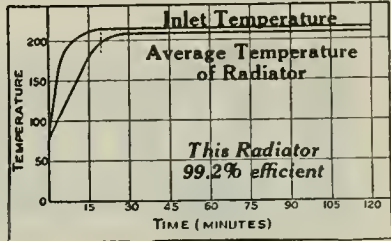
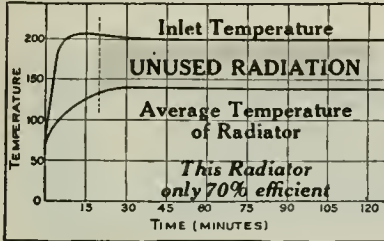

Making Radiation Usable

All who specify and install radiation are agreed upon one point: radiators cannot do their work when they are choked up with air and water.

The two curves are from actual laboratory tests and the same radiator, fitted with two kinds of radiator traps—one of which was the Dunham Radiator Trap—the trap that has been making radiators practically 100% hot since 1903.

You know which trap you would prefer. So would the man who pays the bill for the radiation which he rightfully expects will keep every room warm.

Making radiation usable is as commendable as the conservation of coal.

Send for the entire Dunham story. You will find it interesting.

C. A. DUNHAM COMPANY

Los Angeles 600 Metropolitan Bldg. San Francisco 524 Sheldon Bldg. Seattle 206 First Ave. So.
Portland 410 Board of Trade Bldg. Spokane 405 Sherwood Bldg.
Administrative Office: Chicago, Ill.



AiRWay Multifold Window Hardware for Porches



Windows hung on AiRWay hardware fold in, and when completely opened fit snugly out of the way.

They permit any desired window opening, to protect against draughts,

or to afford the required circulation of air—also the use of screens without the annoyance of having to open the screens in order to open the window.

Send for special catalogue O.C4.



Richards-Wilcox Mfg. Co.

"A Handle for any Door that Slides."
CHICAGO ST. LOUIS LOS ANGELES PHILADELPHIA AURORA, ILLINOIS, U.S.A. BOSTON NEW YORK MINNEAPOLIS SAN FRANCISCO LONDON, ONT.



An Illuminating Triumph

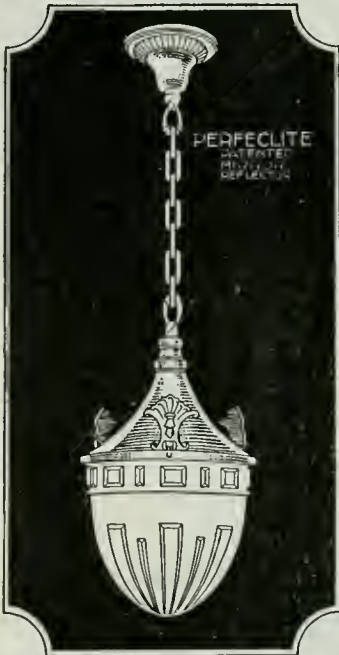

adopting the Master Lighting Fixture in order to profit by its illuminating benefits and current savings.

Study this new fixture in our showrooms—then specify it for that client who demands the ultra modern and best. Over 50 different styles—a type for every residential or industrial requirement. Each one contains the famous patented battery of mirrors—a principle of lighting never before used. Our illuminating specialists are ready to serve you at all times. Catalog free.

"Faster and Faster they come to Perfeclite"—is no idle slogan. It is a concrete fact that goes a long way to prove that this unusually efficient fixture is really a triumph of the illuminating engineers' art. Homes, shops, stores, buildings and institutions everywhere, are rapidly

MYERS & SCHWARTZ

75 New Montgomery St.
San Francisco, Calif.
Phone Sutter 6178

1119 So. Los Angeles St.
Los Angeles, Calif.
Phone 15466

Bungalow Building Blox

Hollow Building Tile
Hollow Partition Tile

California Brick Co.

604 Mission Street
San Francisco, Cal.

BRICK

Red Ruffled Face Brick
Paving Brick
Step and Walk
Brick

BRICK

Enamel Brick
Buff and Old Gold
Pressed Brick

Livermore Fire Brick Works

604 Mission Street
San Francisco, Cal.

Fire Brick and
Molded Fire Tile

Architectural Terra Cotta

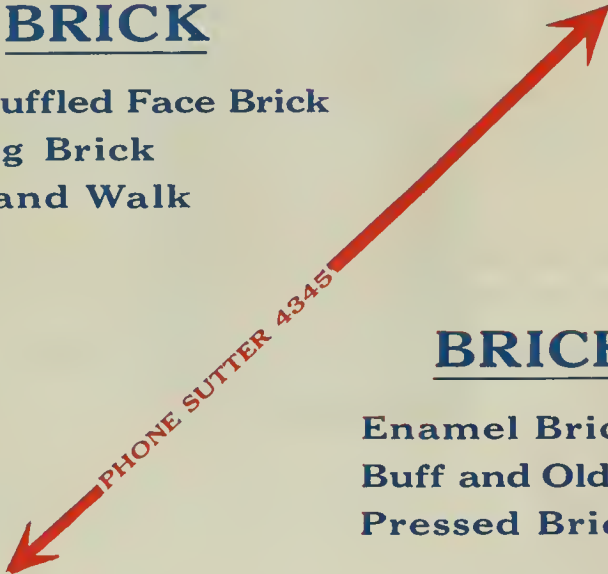

GLASS

FULLER & GOEPP

32 Page Street, San Francisco. Telephone Market 499
PRIVATE EXCHANGE CONNECTING ALL DEPARTMENTS

MANUFACTURERS OF

MIRRORS, ART AND LEADED GLASS

Dealers in **WHITE** Glass for Table Tops, Counter Tops, Sink
Backs Etc. Complete Stock — Prompt Deliveries.

Passenger and Freight Elevators



"MADE IN SAN FRANCISCO"

Factory and Warehouse, 166-180 Seventh
Street, San Francisco. Phone Kearny 66

SPENCER ELEVATOR COMPANY



RA-DO ^{FUMELESS} GAS RADIATORS

ALL CAST IRON—3 Sizes (3, 5, and 7 Sections)

The Ideal "Year-Round" Heating System
For The Home—New or Old

Easiest and Cheapest to Install
Lowest Operating Cost

BAIRD - BAILHACHE COMPANY

MANUFACTURERS

478 Sutter St., San Francisco

'Phone Sutter 6858

OLD MISSION PORTLAND CEMENT COMPANY



Each shipment of "OLD MISSION" Portland Cement is guaranteed not only to equal but to surpass all requirements of the standard specifications for Portland Cement as adopted by the U. S. Government and by the American Society for Testing Materials. A Guarantee Certificate is mailed with the bill of lading of each car, giving number of car, date packed, and number of barrels, over the signature of the chief chemist.

8000 SACKS DAILY

SALES OFFICE:

MILLS BLDG., SAN FRANCISCO
PHONE SUTTER 3075

PLANT:

SAN JUAN, CAL.



Safeguard your building — be it Factory, Warehouse or Power Plant — against spread of flames by specifying

FYER-WALL

ALL METAL DOORS and SHUTTERS

Inspected and Labeled by
Underwriters' Laboratories

FIRE PROTECTION PRODUCTS COMPANY

FIRE DOORS — KALAMEIN — GENERAL SHEET METAL WORK

3117-3119 Twentieth Street, San Francisco

Phone Mission 2607



Keep Down Insurance Premiums

SPECIFY

SAINO FIRE DOORS

Standard Automatic Sliding or Swinging Fire Doors.
Tested and Labeled by the Underwriters' Laboratories.

STEEL SASH AND HOLLOW METAL
UNDERWRITERS WINDOWS

U. S. METAL PRODUCTS CO.

326-338 Tenth Street, San Francisco

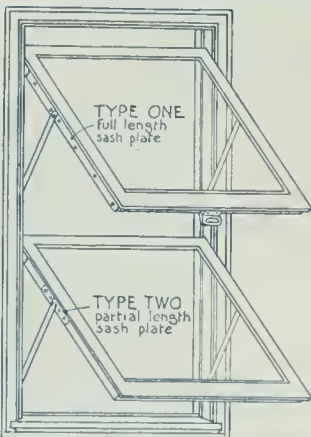

Hauser Reversible Windows

The Ideal Window is one that will operate in any size frame—wood or metal—the HAUSER is such a window—easy to install—a positive protection against rain, dust and wind.

Hauser Window Company

OFFICE AND FACTORY

157 Minna St. (Phone Kearny 3706) San Francisco



LINOTOL

PLASTIC FLOORING
THAT LASTS

*The Floor for
Office and
Showroom*

THE designing of office and store interiors, finish and decoration, especially in the matter of flooring, is receiving increasing attention from architects and builders.

For years Linotol has been used as a floor on fine passenger ships, and has given entire satisfaction. It is now being very generally used in high class offices and places where appearance as well as economy is an important factor.

It is light in weight, beautiful in finish, and practically indestructible. It can be furnished in any variety of designs and color schemes. It is water-tight, fire-proof, and will outlast the building.

*Let our representative tell you
more about Linotol. He will be
glad to call at your convenience.*

HILL, HUBBELL & COMPANY

Manufacturers and Contractors · 1 Drumm Street
San Francisco

LOS ANGELES
410 San Fernando Bldg.

NEW YORK
N. Y.

SEATTLE
209 Grand Trunk Pacific Dock

“LUXOR ENAMEL”

WHITE

HIGH GLOSS

MIRROR-LIKE FINISH

THE FINEST ENAMEL MADE FOR INTERIOR WORK

HIGH IN QUALITY — MEDIUM IN PRICE

UHL BROS., Inc.

SEATTLE

LOS ANGELES

PORTLAND

SAN FRANCISCO

OAKLAND

LEADER WATER SYSTEM

No country home is complete without this modern water system. Running water under pressure whenever and wherever needed. Convenient, economical, sanitary.

**Pacific Pump & Supply
Company, Distributors**

851-853 Folsom Street
SAN FRANCISCO, CALIF.

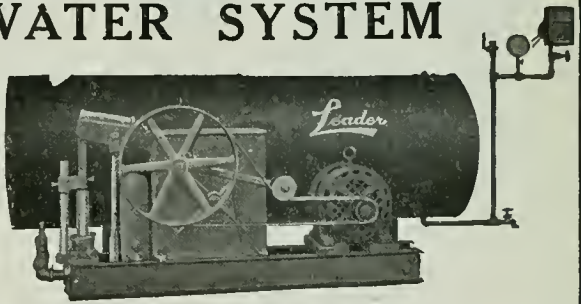

QUALITY HARDWARE



LOCKS AND BUILDERS'
HARDWARE

PALACE HARDWARE CO.

“San Francisco's Leading Hardware Store”

581 MARKET STREET. SUTTER 6060



Pack your Radiator Valves with
Palmetto Twist Packing

It can be unstranded to fit any
size valve. It does not get hard.

H. N. COOK BELTING CO.

401-433 Howard St.

San Francisco, Cal.

**WESTERN
VENETIAN BLINDS
WESTERN**

ELMINATE the unsightly awnings — Preserve the exterior beauty of your buildings by *Specifying*

**WESTERN VENETIAN
BLINDS**

Some 1920 contracts for complete equipment:

- 12-story Mattie Building,
Fresno, California
- 9-story Pantages Building,
Los Angeles, California
- 7-story Marland Refining Bldg.,
Ponca City, Oklahoma
- 10-story Tradesmens Bank Bldg.,
Oklahoma City, Okla.
- 5-story Railway Exchange,
Muskogee, Oklahoma



LOS ANGELES TRUST
AND SAVINGS BLDG.
LOS ANGELES, CAL.



HAAS BLDG.
LOS ANGELES, CAL.



CITIZENS SAVINGS
BLDG.
PASADENA, CAL.



GLOBE GRAIN &
MILLING CO.
LOS ANGELES, CAL.



COUNTY COURT
HOUSE
WALLA WALLA, WASH.

When you consider the fact that **WESTERN VENETIAN BLINDS** take the place of both awning and window shade and will last practically as long as the building stands you'll realize that they are the logical equipment for modern buildings

WESTERN BLIND & SCREEN CO.
2704 LONG BEACH AVE.
LOS ANGELES CALIFORNIA

United States Steel Products Co.

Rialto Bldg., San Francisco

SELLERS of the products of the American Bridge Co., American Sheet and Tin Plate Co., American Steel and Wire Co., Carnegie Steel Co., Illinois Steel Co., National Tube Co., Lorain Steel Co., Shelby Steel Tube Co., Tennessee Coal, Iron and Railroad Co., Trenton Iron Co.

MANUFACTURERS OF

Structural Steel for Every Purpose—Bridges, Railway and Highway—"Triangle Mesh" Wire Concrete Reinforcement—Plain and Twisted Reinforcing Bars—Plates, Shapes and Sheets of Every Description—Rails, Splice Bars, Bolts, Nuts, etc.—Wrought Pipe, Trolley Poles—Frogs, Switches and Crossings for Steam Railway and Street Railway—"Shelby" Seamless Boiler Tubes and Mechanical Tubing—"Americore" and "Globe" Rubber Covered Wire and Cables—"Reliance" Weatherproof Copper and Iron Line Wire—"American" Wire Rope, Rail Bonds, Springs, Woven Wire Fencing and Poultry Netting—Tramways, etc.

United States Steel Products Co.

OFFICES AND WAREHOUSES AT

San Francisco - Los Angeles - Portland - Seattle



Specify **BOWSER**

ESTABLISHED 1885

Thirty-five years ago Bowser blazed the trail to efficient gasoline and oil storage and handling. Today Bowser offers accurate, economical and safe equipment for solving all gasoline and oil storage and service problems—backed by those thirty-five years experience. Whether it's in a garage, a railroad, factory or dry cleaning plant, you are serving your client best when you specify Bowser Equipment.

—Write for Illustrated Booklet A-03—

S. F. BOWSER & COMPANY, Inc.

1303 Creighton Ave.,
FORT WAYNE, INDIANA

612 Howard Street,
San Francisco, Calif.

1225 So. Olive Street,
Los Angeles, Calif.

LONDON

PARIS

HAVANA

SYDNEY



House at Cornwall-on-Hudson, N. Y. Finished with Old Virginia White. Rogers & Zogbaum, Architects, New York

Cabot's Old Virginia White

A Soft, Brilliant White for Shingles, Siding and Similar Woodwork. As Bright and Clean as New Whitewash, and as Lasting as Paint.

Architects and others have tried for years to get a paint that would give the same beautiful, brilliant white as new whitewash, and would also be durable and clean and not rub off like whitewash. But paint was always "painty" — hard, cold and heavy. Old Virginia White is a shingle-stain compound that has solved the problem. It is as clean, cool and brilliant as fresh whitewash, and as lasting as paint; but it is not messy like whitewash, nor painty like paint, although it costs less and goes farther than paint.

Send for Sample Shingle and Circular showing other fine houses finished with Old Virginia White

SAMUEL CABOT, Inc., Mfg. Chemists, Boston, Mass.

Cabot's Creosote Stains, Stucco and Brick Stains, "Quilt," Mortar Colors, Dampproofing, Waterproofings, Conservo Wood Preservative, etc.

Pacific Materials Co., San Francisco
The Waterhouse-Wilcox Co., Los Angeles

S. W. R. Dally, Seattle
Timms, Cress & Co., Portland

Theo. F. Snyder, San Diego, Cal.



CENTRAL HIGH SCHOOL, MINNEAPOLIS, MINN.

Architect, William B. Ittner

Contractors, Pike & Cook Co.

Glazed by Forman, Ford & Co



The above Trade-Mark appears on every light

Completely equipped with American Window Glass Co.'s Double Strength AA Quality First Choice of Leading Architects

Because of its absolute dependability, American Window Glass has been used in many fine buildings. Our care in inspection practically eliminates all imperfections and assures uniformity in thickness.

American Window Glass Co., General Office, Pittsburgh, Pa.

DOMESTIC SALES OFFICES

- New York, 220 Fifth Avenue
- Chicago, 1011 Peoples Gas Building
- Boston, Mass., 43 Tremont Street
- San Francisco, Cal., 862 Mission Street
- St. Louis, Mo., 1303 Syndicate Trust Building
- Memphis, Tenn., 440 North Main St.
- New Orleans, La., 904 Hennen Bldg.
- Atlanta, Ga., 1408 Candler Building

EXPORT SALES OFFICES

- Havana, Cuba, Apartado No. 930
- Buenos Aires, Argentina
- Mexico City, Mex., Apartado Postal No. 237
- Barranquilla, Colombia
- Bogota, Colombia
- Valparaiso, Chile
- Lima, Peru
- Toronto, Canada, 205 Continental Life Building

Makes Garbage Burn Itself

The KERNER INCINERATOR

"Built-in-the-Chimney"



requires no coal, gas or any other fuel other than the dry waste deposited in the handy little hopper door. All you need do is to throw the garbage, waste paper, tincans, bottles and other refuse in the hopper door — and occasionally light the incinerator in the basement.

The dry waste burns readily and, in burning dries the wet waste so it also becomes fuel. Bottles and tin cans are dried, sterilized and later dropped into the ash pit.

SANITARY—ECONOMICAL—CONVENIENT—ODORLESS

Kerner Incinerator Co.

77 O'Farrell St. Factory, 38 Stanford St.

San Francisco

Patented Aug. 25, 1914; May 18, 1919



SIMPLEX BURNERS

For High or Low Pressure Boilers, Water Heaters, Kiln Dryers, Furnaces, Etc. Operated by Fractional H. P. Motors. Guaranteed for Efficiency and Durability.

BUNTING IRON WORKS

1215 FIRST NATIONAL BANK BLDG.
SAN FRANCISCO Phone Sutter 3225

TRADE MARK

Factory BERKELEY

Member of the Oil Burners Manufacturers' Association of California.

Fess System Turbine Fuel Oil Burner

The latest word in the science of burning fuel oil in an efficient and economical method

Ask for Bulletin No. 20

FESS SYSTEM CO., Inc.

1310 S. HILL ST.,
LOS ANGELES

218-220 Natoma Street, San Francisco

HOUSTON,
TEXAS

Member of the Oil Burners Manufacturers' Association of California.

OIL BURNER EQUIPMENTS

Low Pressure Air and Rotary Mechanical Atomizing Types

Refrigerating and Ice-Making Machines

Direct Expansion and Brine Circulating Systems

T. P. JARVIS MANUFACTURING CO.

CONTRACTING ENGINEERS AND MANUFACTURERS

275 Connecticut Street, San Francisco

Phone Market 3397

Member of the Oil Burners Manufacturers' Association of California.

JOHNSON'S ROTARY CRUDE OIL BURNER

Can be installed in any BOILER or FURNACE

Gives Satisfactory Results. Simple to Operate—
Automatic—Safe. Let us tell you more about this
Oil Burner.

S. T. JOHNSON CO.

1337 Mission Street - San Francisco, Cal.

Ask for Bulletin No. 28

Phone Market 2759

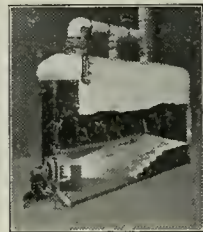

BURNER IN OPERATION

Agencies: SEATTLE LOS ANGELES FRESNO SAN DIEGO SACRAMENTO
Member of the Oil Burners Manufacturers' Association of California.



Pump Governors
 Oil Burner Governors
 Reducing Valves
 Safety Valves
 Oil Valves
 Blowoff Valves
 Boiler Feed Water
 Regulators

Oil Pumping Sets
 Little Giant Improved
 Oil Burners
 Duplex Oil Pumps
 Rotary Oil Pumps
 Oil Heaters
 Draft Gauges
 Boiler Feed Pumps

G. E. WITT CO., Inc.
ENGINEERS

Manufacturers and Distributors

862-864 HOWARD ST.

Phone Douglas 4404

SAN FRANCISCO, CAL.

MEDUSA
WATERPROOFING
 PATENTED

THERE is no other water-
 proofing "Just as good" as
 "MEDUSA"

The "Original" waterproofing under which other pastes and
 powders are licensed.

PACIFIC MATERIALS CO.
 525 MARKET STREET, SAN FRANCISCO

A. F. Edwards, Pres.
 J. M. Fabbris, Vice-Pres.
 J. A. Mackenzie, Secy.

Office Telephone:
 MARKET 5070

Chas. F. Eisele, Asst. Mgr.
 J. Rubiolo, Asst. Mgr.
 D. A. Batsford, Asst. Mgr.

AMERICAN
MARBLE & MOSAIC CO.

25-59 Columbia Square, San Francisco, Calif.
 Near Folsom St., Bet. 6th and 7th Sts.

Factory on Waterfront, South San Francisco. Phone South San Francisco 161

Fenestra
SOLID STEEL WINDOWS

DETROIT STEEL PRODUCTS CO., Detroit

Direct Factory Branch, 68 Post Street, San Francisco

Phone Sutter 125



The Architect and Engineer

CONTENTS FOR APRIL, 1921

	PAGE
CASA FLORES, RESTORATION FOR MRS. C. E. NOYES, PASADENA	FRONTISPIECE
<i>Carleton Monroe Winslow, Architect</i>	
A RESTORED SPANISH ADOBE	47
<i>Irving F. Morrow</i>	
OSWALD SPEIR—1864-1921	56
<i>A Tribute by C. K. S.</i>	
THE ROBERT DOLLAR BUILDING	57
<i>I. F. M.</i>	
HOW ONE EASTERN INDUSTRY SOLVED ITS HOUSING PROBLEM WITH CONCRETE	79
AWARDS MADE IN SMALL HOUSE COMPETITION	85
FIFTY-FOURTH INSTITUTE CONVENTION IN MAY	86
BUILDING LOANS AT SIX PER CENT	87
THE PLANNING OF THEATRES AND AUDITORIUMS	91
<i>Edwin H. Flagg</i>	
RECORD CALIFORNIA QUARRY BLAST	97
EDITORIAL	102
WITH THE ARCHITECTS	105
WITH THE ENGINEERS	109

PUBLISHED MONTHLY BY

THE ARCHITECT AND ENGINEER, INC.
626-27 FOXCROFT BUILDING, SAN FRANCISCO

W. J. L. KIERULFF
President

FREDERICK W. JONES
Vice-President

L. B. PENHORWOOD
Secretary



CASA FLORES. RESTORATION FOR MRS. C. E. NOYES, PASADENA, CAL.
CARLETON MONROE WINSLOW, ARCHITECT

THE ARCHITECT AND ENGINEER

APRIL
1921



Vol. LXV
No. 1

A Restored Spanish Adobe

By IRVING F. MORROW

TO the traveler in California who is responsive to plastic beauty and the romance of history there must come many a pang of sadness on witnessing the decay of the relics of the age of Spanish colonization. Monuments of obvious importance have been accorded a grudging and often ill-considered attention; yet after all, when structures are as arresting as the Franciscan Missions, it is reasonable to assume that the public opinion of today is sufficiently enlightened to prevent their complete annihilation. The greatest danger is to the remains of minor scale, but no less conspicuous charm; former private residences, for the most part, which are slowly disintegrating before our eyes. Under present conditions few of them are of economic value—and who, in an age of rampant money-getting, can be expected to maintain a building merely because of its beauty or its historic associations? (Might it not reasonably be considered the part of the state to perform functions which admittedly should be performed, but which private initiative can not be expected to undertake?)

I shall never forget my feelings the day I first came upon one of these neglected adobe houses, as I strolled down the highway below San Miguel. From the outside of the walls plaster scaled in large patches, and most, if not all, of the muntined window panes were shattered. Within, accumulations of filth littered the floors, and a tottering stairway led to bedrooms strewn with depressing fragments of broken furniture and torn mattresses. It had been a building of dignified simplicity, of charming proportions and mass, charged with delicate poetry and romance; it was still, structurally

speaking, intact, but deserted and defiled. As a symbol of heedless materialism its neglect seemed more eloquent even than the paltry prosperity of the town nearby. Old San Juan (that dedicated to the Baptist) offers similar examples of distressing neglect, as do also Monterey and many another seat of early Spanish activity. However, I have no intention even to attempt a catalogue of these misfortunes, a task which I could not hope to accomplish with a tolerable degree of completeness. I wish only to indicate that examples are continually coming to the attention of any observant wayfarer.

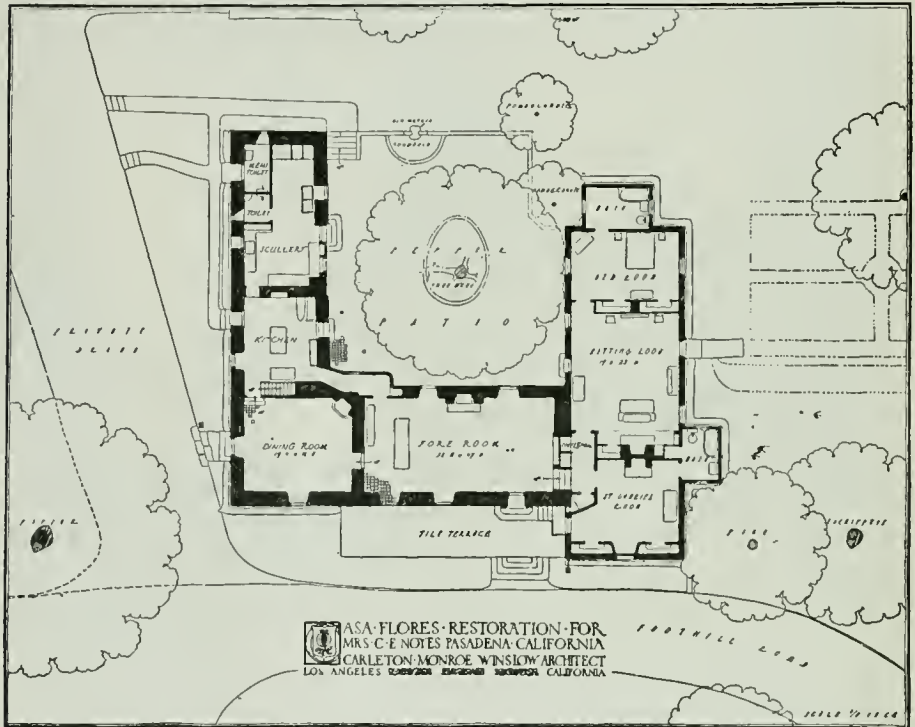

CASA FLORES. RESTORATION FOR MRS. C. E. NOYES, PASADENA, CAL.
 Carleton Monroe Winslow, Architect.

Such a relic of early days Mr. Carleton Monroe Winslow has rescued from this all-too-prevalent fate. The result is Casa Flores, the charming residence of Mrs. C. E. Noyes, at Pasadena. The main portion of the building is a Spanish adobe which dates from more than a century back. It was at one time used by General Flores as the headquarters of the Spanish army. According to tradition it was also for a considerable period the residence of Governor Pico, and for many years it was known as the "Governor Pico House." Before restoration it had become most unattractive in appearance, due to the usual neglect and inappropriate modern accretions which obscured its native qualities. Mr. Winslow's task involved a dual loyalty to past and present at once. The success of his accomplishment may be

measured by the fact that the house preserves the original flavor of the Spanish-Californian architecture, avoiding at the same time any suggestion of living in a museum.

The old adobe walls were found practically intact, and were maintained wherever possible. The walls of a frame addition built some forty years ago were covered with brick and plastered uniformly with the original adobe. All new work has been carried out in a congenial spirit. Color has been freely used. The plaster walls are a warm gray of a pinkish yellow tone. The window shutters are a clear green, with lines of various colors bordering the conventional pierced ventilating openings. The sash are bright French blue picked out in orange yellow.

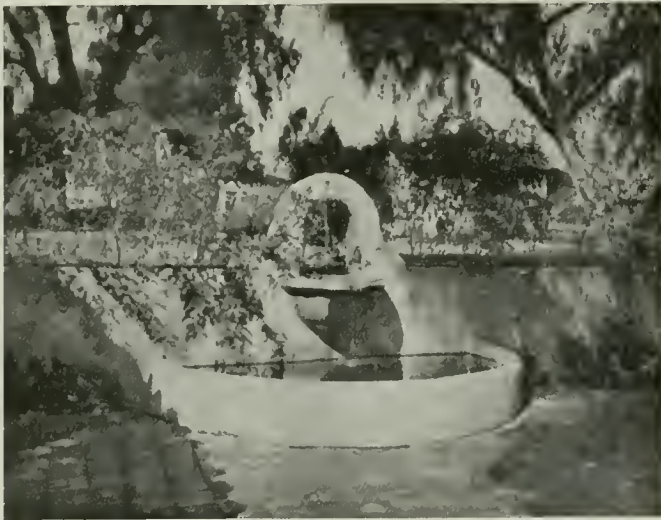

FOUNTAIN IN PATIO. CASA FLORES,
RESTORATION FOR MRS. C. E. NOYES, PASADENA.
Carleton Monroe Winslow, Architect.

The patio, which was found filled to a considerable depth with debris, was excavated to the original level. A retaining wall was added along the far side, with a fountain, into which was built an old *metate* which was dug up in the patio.

Inside as well as outside original work was conserved wherever possible. In the passage off the main room was an old confessional, which was left intact. As the original building was built before the days of stock design and large-scale production, there are hardly two doors or windows which are alike. Furniture and lighting fixtures were specially designed by the architect.

This building is but a modest sized house, and makes no other pretense. Yet every Californian should consider Mr. Winslow's achievement in the nature of a public service.

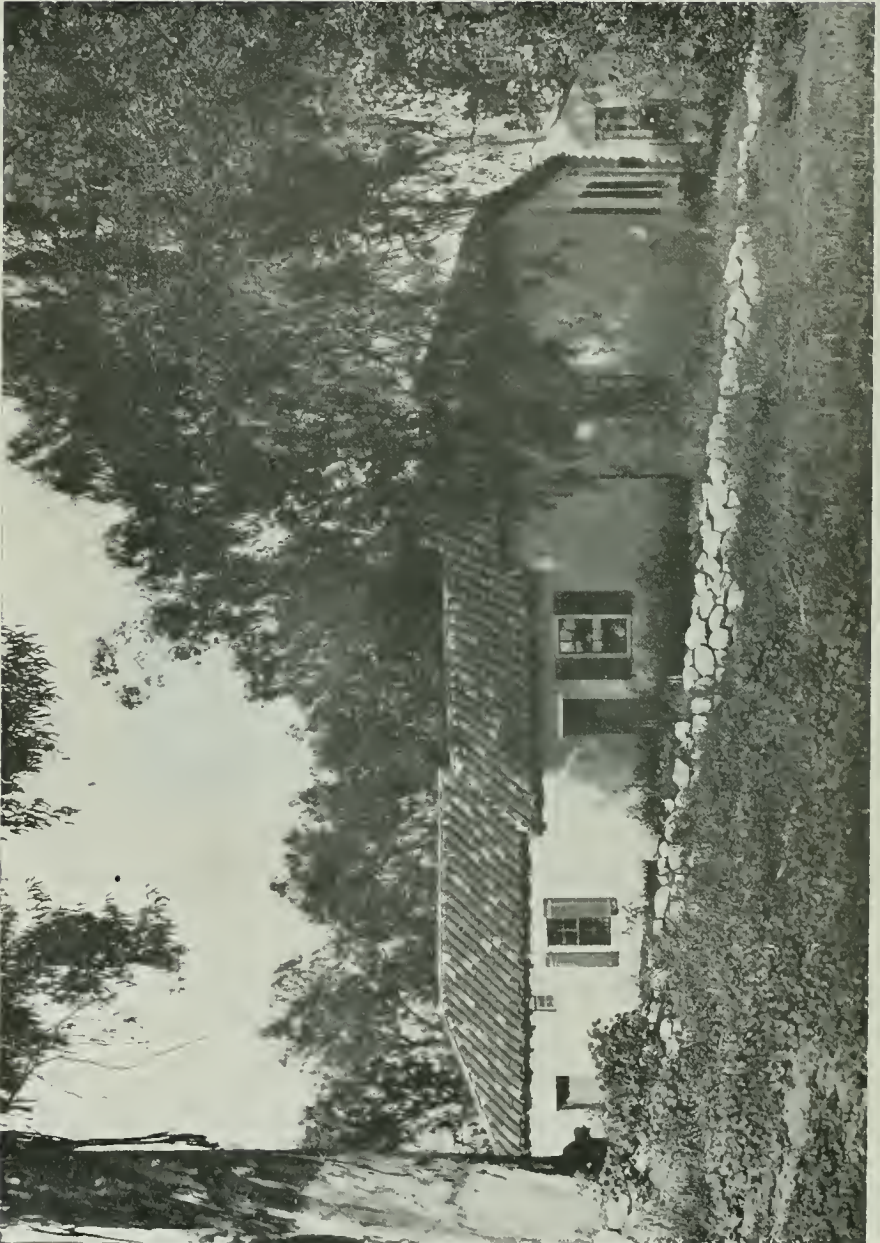

CASA FLORES. RESTORATION FOR MRS. C. E. NOYES, PASADENA, CAL.
CARLETON MONROE WINSLOW, ARCHITECT



PATIO. CASA FLORES, RESTORATION FOR MRS. C. E. NOYES,
PASADENA, CAL. CARLETON MONROE WINSLOW, ARCHITECT



PATIO. CASA FLORES, RESTORATION FOR MRS. C. E. NOYES,
PASADENA, CAL. CARLETON MONROE WINSLOW, ARCHITECT.



PATIO. CASA FLORES, RESTORATION FOR MRS. C. E. NOYES,
PASADENA, CAL. CARLETON MONROE WINSLOW, ARCHITECT

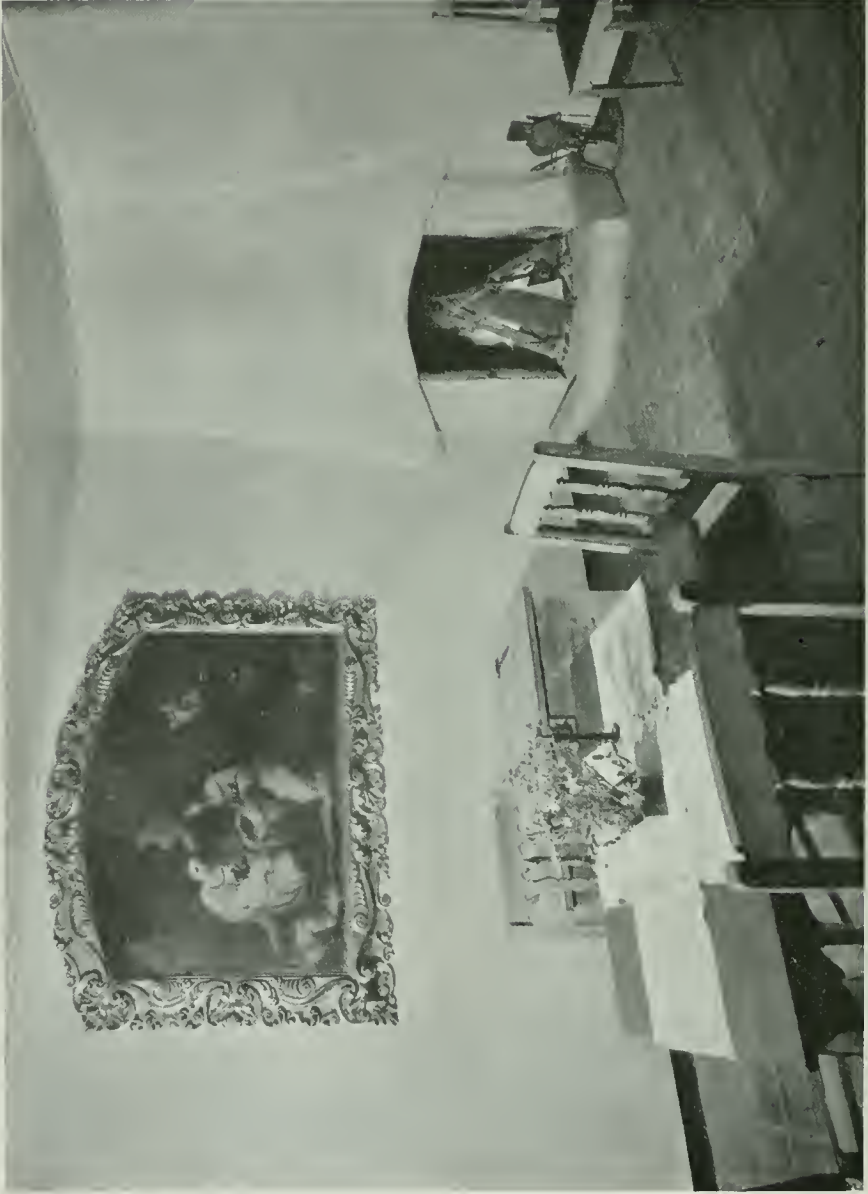

DINING ROOM. CASA FLORES, RESTORATION FOR MRS. C. E. NOYES,
PASADENA, CAL. CARLETON MONROE WINSLOW, ARCHITECT.



MAIN ROOM. CASA FLORES, RESTORATION FOR MRS. C. E. NOYES,
CARLETON MONROE WINSLOW, ARCHITECT.
PASADENA, CAL.

Oswald Speir — 1864-1921

ONE of my really prized mementos is an old group photograph of my class in architecture, taken with our revered Professor Ware, and the very earnest and kindly guide who had just shown us something of burnt-clay processes and products at the plant of the Pirth Amboy Terra Cotta Company. That was my introduction to Oswald Speir, and to what, as events determined, was to be the field of his special and highly important life work. He was already at that time a distinguished terra-cotta producer. He became also, in later years, the distinguished and authoritative public educator for our nation-wide terra-cotta industry.

Oswald Speir was born in New Orleans in 1864, his parents removing later to New York City. There he studied architecture for a year, but his father's death called for the sacrifice of his professional ambition, and he went to work as a young man for the Pirth Amboy Terra Cotta Company. He was, therefore—strange as this may sound—one of the pioneers of our modern terra-cotta industry; and the splendid development of this industry is due in no small measure to his own efforts and contributions as he rose in the ranks of his company. Few of us have realized, in talking over our problems with Mr. Speir, that in the earlier years when the resources of this invaluable material were much less developed, he was giving counsel and working out terra-cotta problems with Charles F. McKim and Stanford White; and that without the enlightened manufacturer's co-operation, which he then supplied, such masterpieces as the Herald building, the Judson Memorial and the Century Club would hardly have been possible. These buildings, while claimed by New Yorkers, are now a part of the architectural legacy of the nation; and it is not too much to say that the spirit of craftsmanship animating Mr. Speir had much to do with their success, and through them and like buildings with the renaissance in American architecture they signaled.

At the height of his powers as a technician and manufacturer, Mr. Speir suffered a physical breakdown which led him to California; and that is why we are privileged to honor his memory here as well as to read tributes from his Eastern associations. In his dozen years among us, with Gladding, McBean & Co., he resumed in a more limited but promising field the work of co-operation and education in which he had been so important a factor in the East. Without any disparagement of salesmanship, he was never in the world a mere salesman. With full respect for the dignity and importance of production, he was also more than a producer. He was what the times demanded in American architecture and the terra-cotta industry—a thoroughly qualified, scholarly and sympathetic interpreter for his industry of the varied resources and possibilities of this universal material in architectural expression. His qualifications and his success in this field impelled me to protest, several years ago, that the work he was doing should be nation-wide, not confined to the architects of the Pacific Coast. As if in confirmation of this judgment, he was drafted only last year for this very service by the integrated national industry and made Executive Secretary of the National Terra Cotta Society. His work in this capacity had already begun to show splendid results, as we have here realized only in small part, when it was cut short by his untimely death on February second.

But after all is said—and this is only a beginning—it is the personal quality of a man that appeals to us as men, even more than his abilities. So while our terra-cotta industry and our profession are both truly, but impersonally, bereaved in the death of Oswald Speir, there are very, very many of us who will mourn this friendly man almost as a brother. And our lives are indeed richer through his manly integrity and grace of character, his genuine, universal sympathy and the unflinching happiness of his presence. C. K. S.

The Robert Dollar Building

THE new San Francisco—architecture of the pre-war period can hardly be described as old; and yet the several years' interruption of building was so complete that its resumption inevitably suggests the inauguration of a period—the new San Francisco may fairly be said to have begun with the Robert Dollar building. There have since been erected or started in the city's financial district structures of greater height and mass, but it is doubtful if any to date can claim a superior interest and beauty. The definiteness of conception, the grace, refinement, and meticulous care of handling, place it at once entirely out of the class of ordinary business structures. It is, in effect, and obviously prides itself upon being, un-commercial in the ordinary ruthless sense; which, however, in no wise prevents it from being an eminently practical achievement in the broadest and truest meaning of that word, a monument alike to the intelligence and ideals of its owners and the ability of its designer.

Alteration jobs are proverbially difficult problems. At every turn one is hampered by restrictions of another's making, often unsuspected until encountered, and generally irrelevant to the new purpose. The resulting solution, however ingenious, is apt to be in the nature of a makeshift. And yet there now and again arise occasions when an architect, employing a sort of higher ingenuity, can turn apparently unfortunate conditions to good account, just as one often draws the most interesting inspirations from accidents in the shape or contour of the site. Unwonted difficulties serve as a challenge to one's best efforts, and stimulate the investigation of interesting possibilities which might never have been otherwise discovered.

Such, in short, is the case of Mr. Chas. W. McCall's building. It will probably surprise even architects to learn that it is an alteration job; which only goes to emphasize the success of Mr. McCall's accomplishment. It is not too much to say that he has employed a degree of real creative ability in circumventing his initial disadvantages. However difficult the conditions imposed by the original structure may have made his work, the result reveals neither perplexity nor effort. It is, as far as the unprejudiced observer can tell, a freely conceived design.

The original building was a five-story concrete structure, whose form (or "design") was in the nature of a literal paraphrase of mathematical calculations. The problem was to double the height, and produce a building in interest and dignity worthy to represent one of our foremost steamship companies. On the purely ornamental side the difficulties were reasonably easy to overcome. All of the "architecture" on the building consisted of sheet metal excrescences subject to simple and painless amputation. This left Mr. McCall in the presence of a direct concrete structure which he could regard, within certain limits, somewhat as the sculptor proverbially regards his block of stone—a mass from which his vision may be disengaged. Structural difficulties offered more serious problems. Certain questions of pure engineering called for solution. Large cantilevers were added to the inner property line columns to effect a uniform loading on the pile footings. These cantilevers were placed above instead of below the basement floor, and before the addition of the upper stories. This left it unnecessary to cut the heavy existing basement floor, and also eliminated the difficult problem of working below high water level—a problem which, however, had to be met in the excavation for the new elevator pit.

These, after all, were but questions of mechanical ingenuity. Architectural problems, properly speaking, also pressed. Lobby, stair, and elevator facil-

ities were inappropriate and inadequate in size and arrangement for the new purposes. The structural bays on the two street frontages varied in both size and in scheme of subdivision. These are only among the more obvious of the difficulties encountered. Into all of these more or less disorganized or anomalous elements Mr. McCall had to introduce order—or composition (which is the same thing). A glance at plans and photographs will show the re-arrangements effected in lobby and elevator plans; also the interesting variety in treatment drawn from the varying bay units—a diversity in no wise inconsistent with the strict unity of the whole design.

The general "style" of the building—its prevailing verticality—has evolved in the solution of this legacy from the original structure. The grace of the treatment and the ornamental refinement (at first sight one

ROOF PLAN

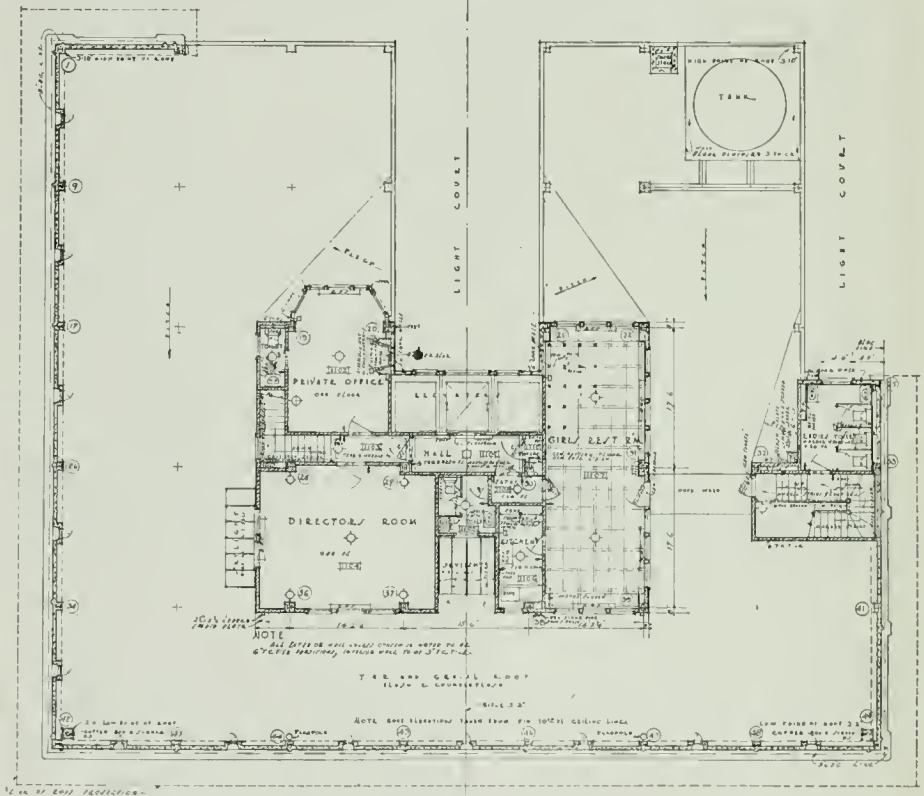

ROOF PLAN, ROBERT DOLLAR BUILDING, SAN FRANCISCO
Chas. W. McCall, Architect

might be almost tempted to say over-refinement) are of course Mr. McCall's independent contribution. The purpose of the building as the headquarters of a steamship company has been kept constantly in mind in the design of the detail. Throughout all ornamental features of both exterior and interior there has been consistent use made of appropriate symbols—the house flag, marine life, and ship details. Special attention has been given to the public lobby and the private offices of the Robert Dollar Line. The latter are finished in various hard woods, with special care in the handling of color and texture. The more important lighting fixtures and furniture have also been executed from the architect's designs.

I. F. M.

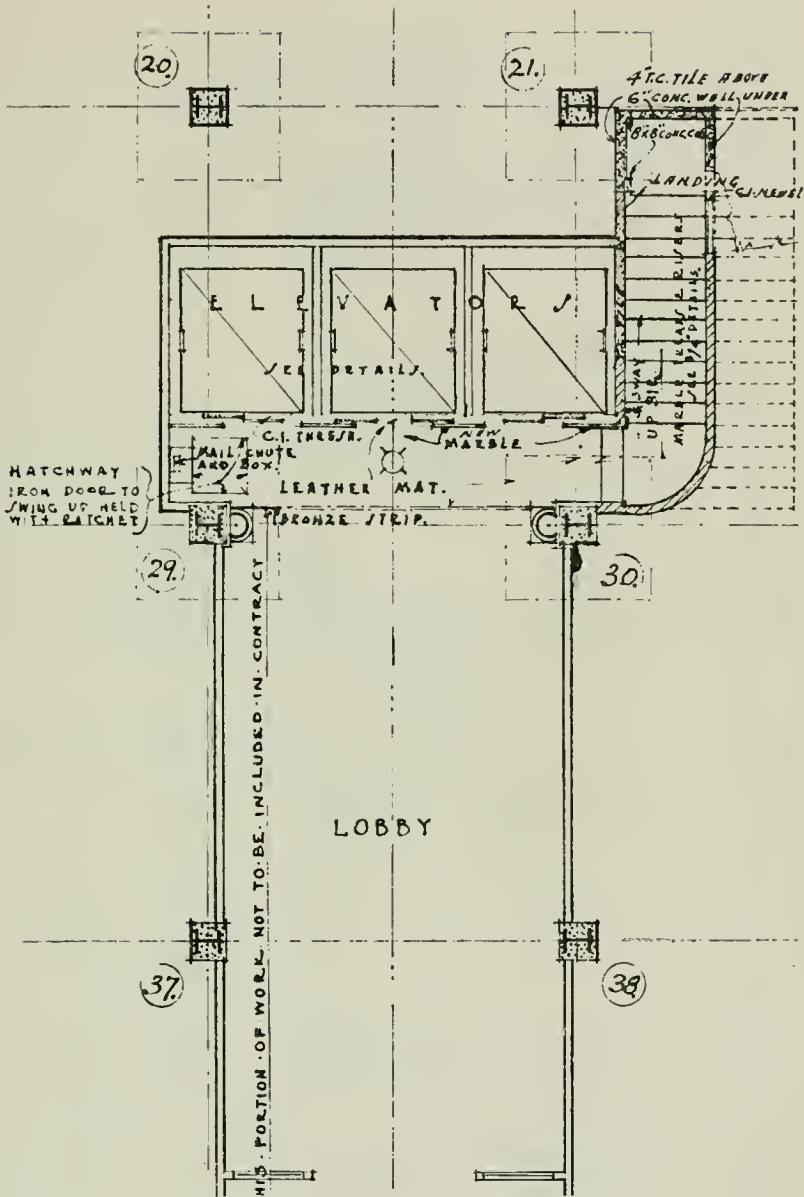

LOBBY PLAN, ROBERT DOLLAR BUILDING, SAN FRANCISCO
CHAS. W. McCALL,
ARCHITECT

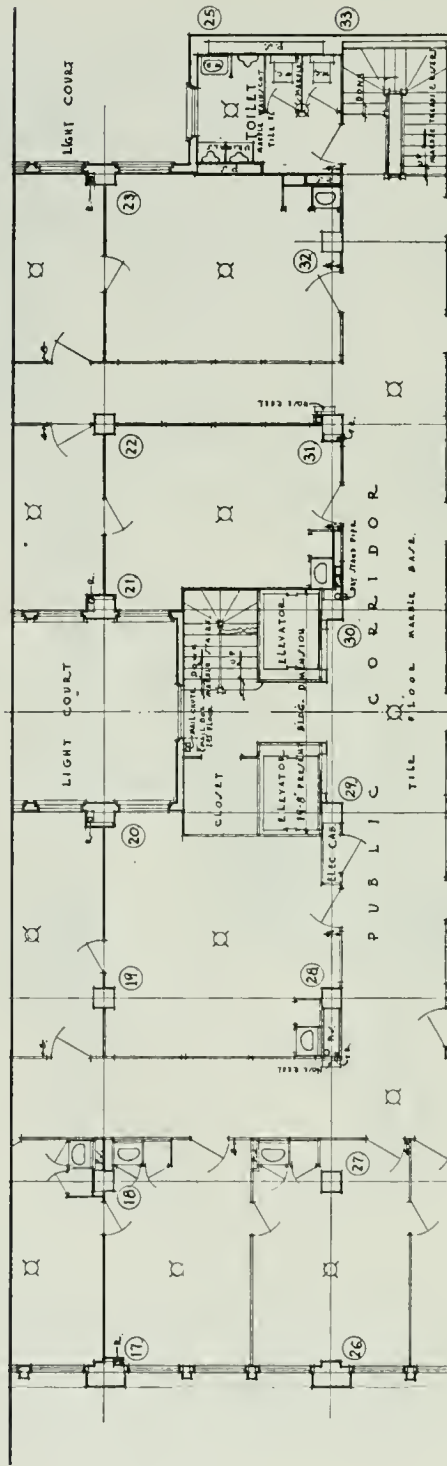

LOBBY AND ELEVATOR ARRANGEMENT OF ORIGINAL BUILDING, ROBERT DOLLAR BUILDING, SAN FRANCISCO

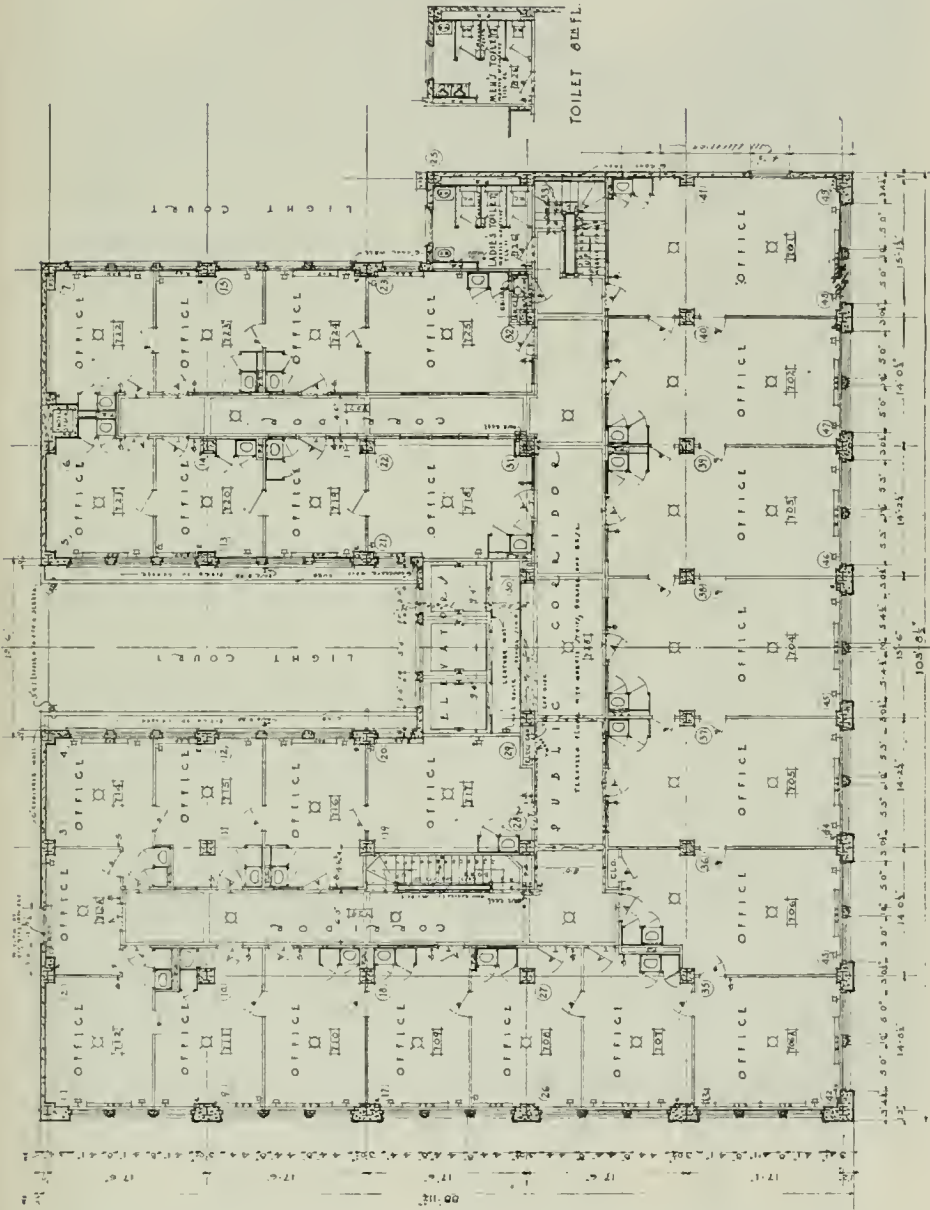

TYPICAL FLOOR PLAN, ROBERT DOLLAR BUILDING, SAN FRANCISCO CHAS. W. McCALL, ARCHITECT

(Shows widening of court in new portion)

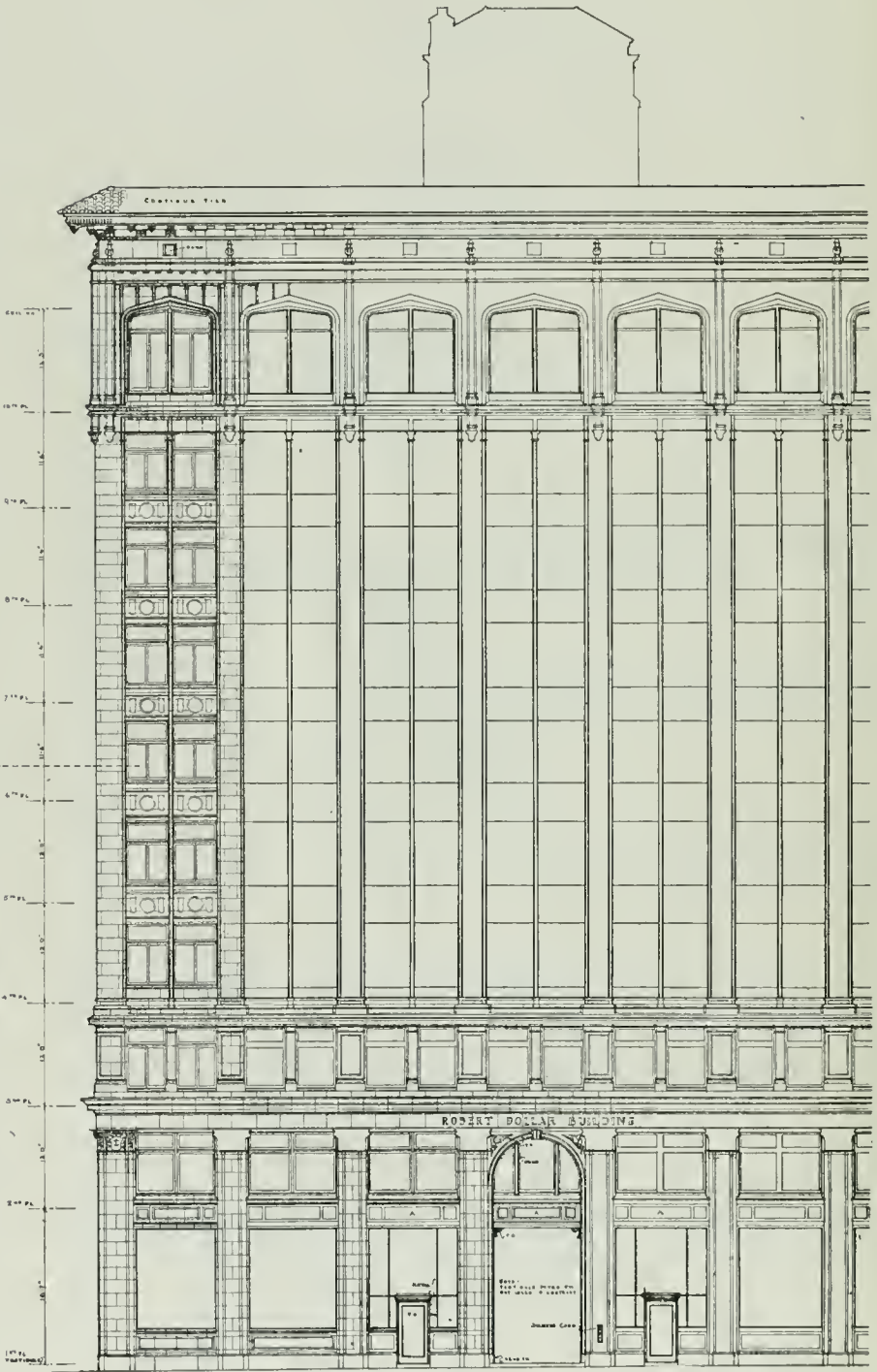

- CALIFORNIA ST. ELEVATION -

CALIFORNIA STREET ELEVATION, ROBERT DOLLAR BUILDING,
SAN FRANCISCO. CHAS. W. McCALL, ARCHITECT.

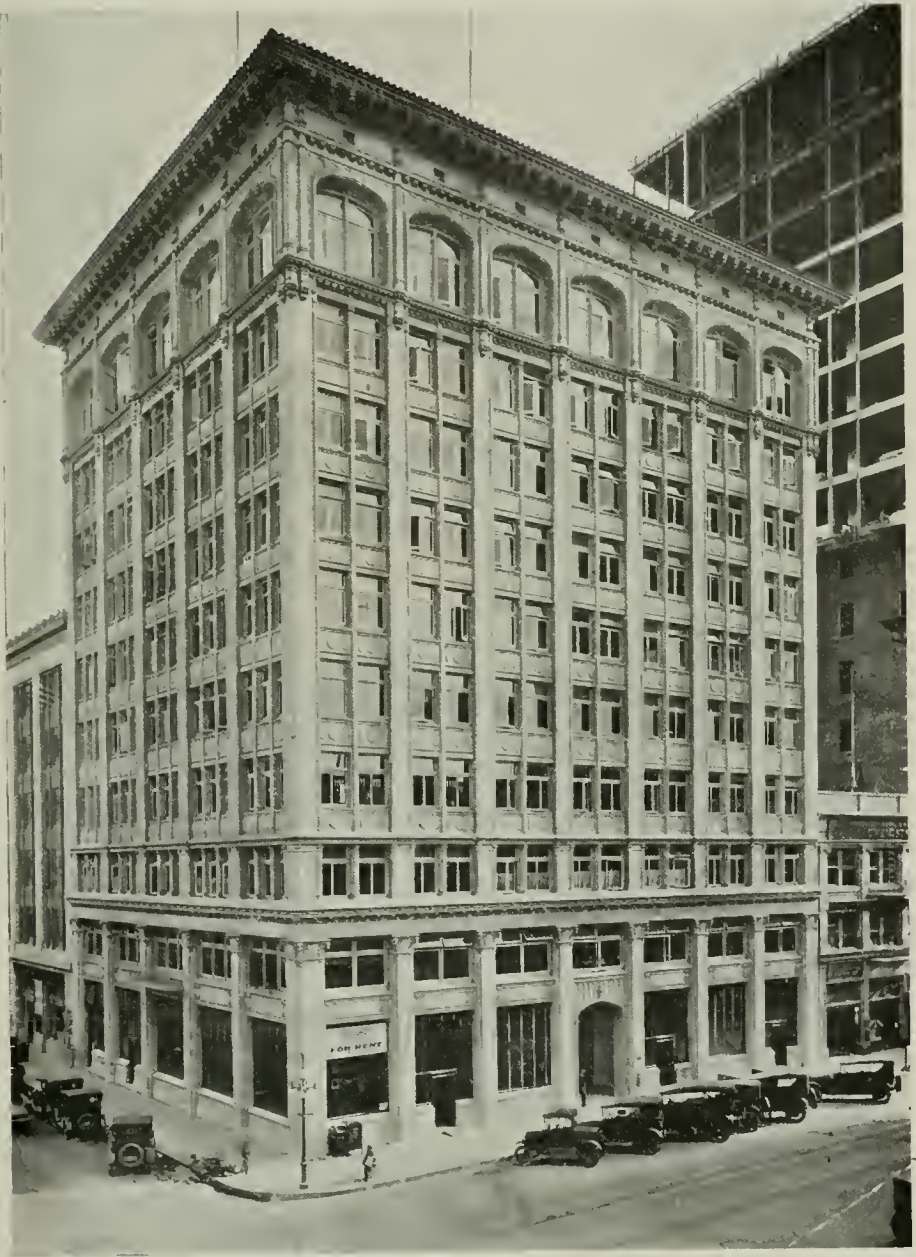

ROBERT DOLLAR BUILDING, SAN FRANCISCO
CHAS. W. McCALL, ARCHITECT

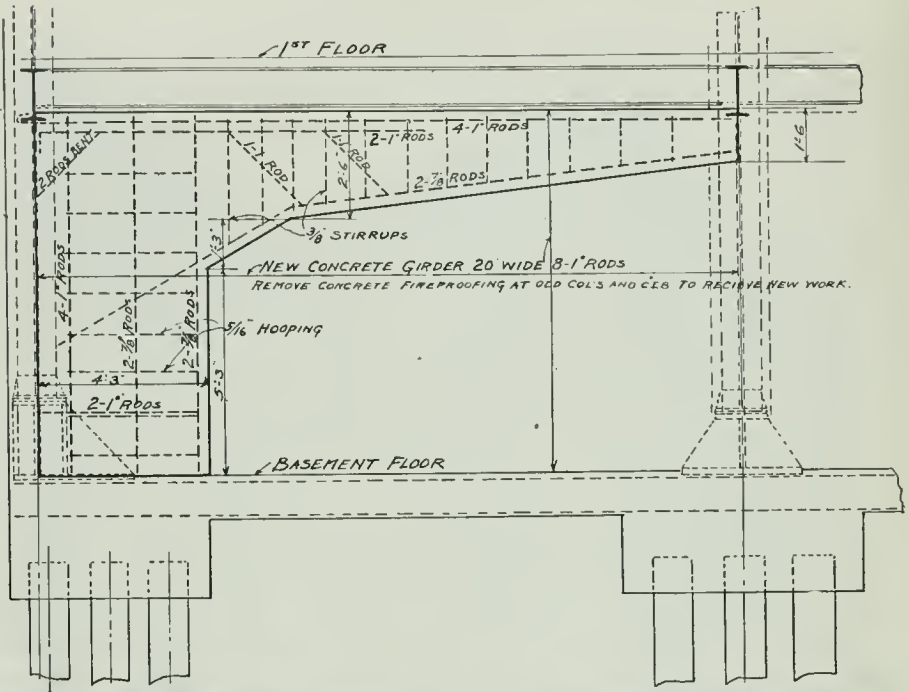

CANTILEVER IN BASEMENT AT INNER PROPERTY LINE
 COLUMNS, ROBERT DOLLAR BUILDING, SAN FRANCISCO
 CHAS. W. McCALL, ARCHITECT



ROBERT DOLLAR BUILDING, SAN FRANCISCO
CHAS. W. McCALL, ARCHITECT

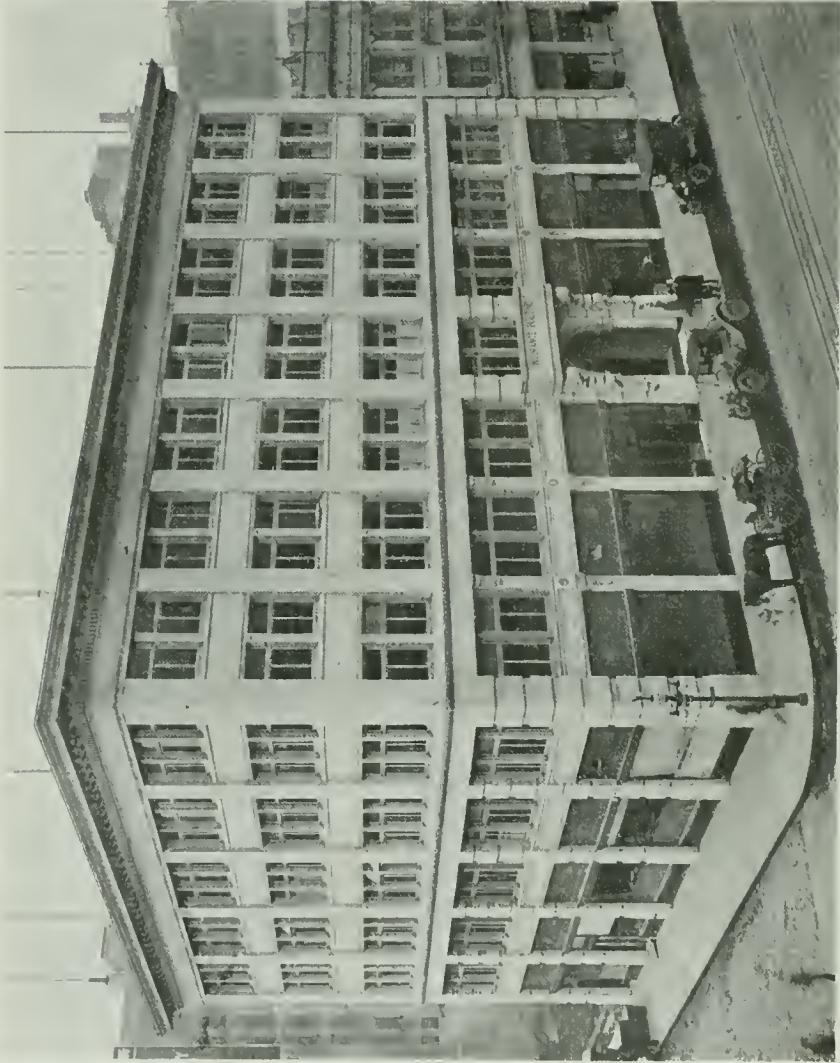

THE ORIGINAL BUILDING, ROBERT
DOLLAR BUILDING, SAN FRANCISCO



ENTRANCE LOBBY, ROBERT DOLLAR BUILDING, SAN FRANCISCO
CHAS. W. McCALL, ARCHITECT



ENTRANCE, ROBERT DOLLAR BUILDING, SAN FRANCISCO
CHAS. W. McCALL, ARCHITECT



ENTRANCE TO MANAGER'S OFFICE—BANK OF ASIA—ROBERT CHAS. W. McCALL, ARCHITECT DOLLAR BUILDING.

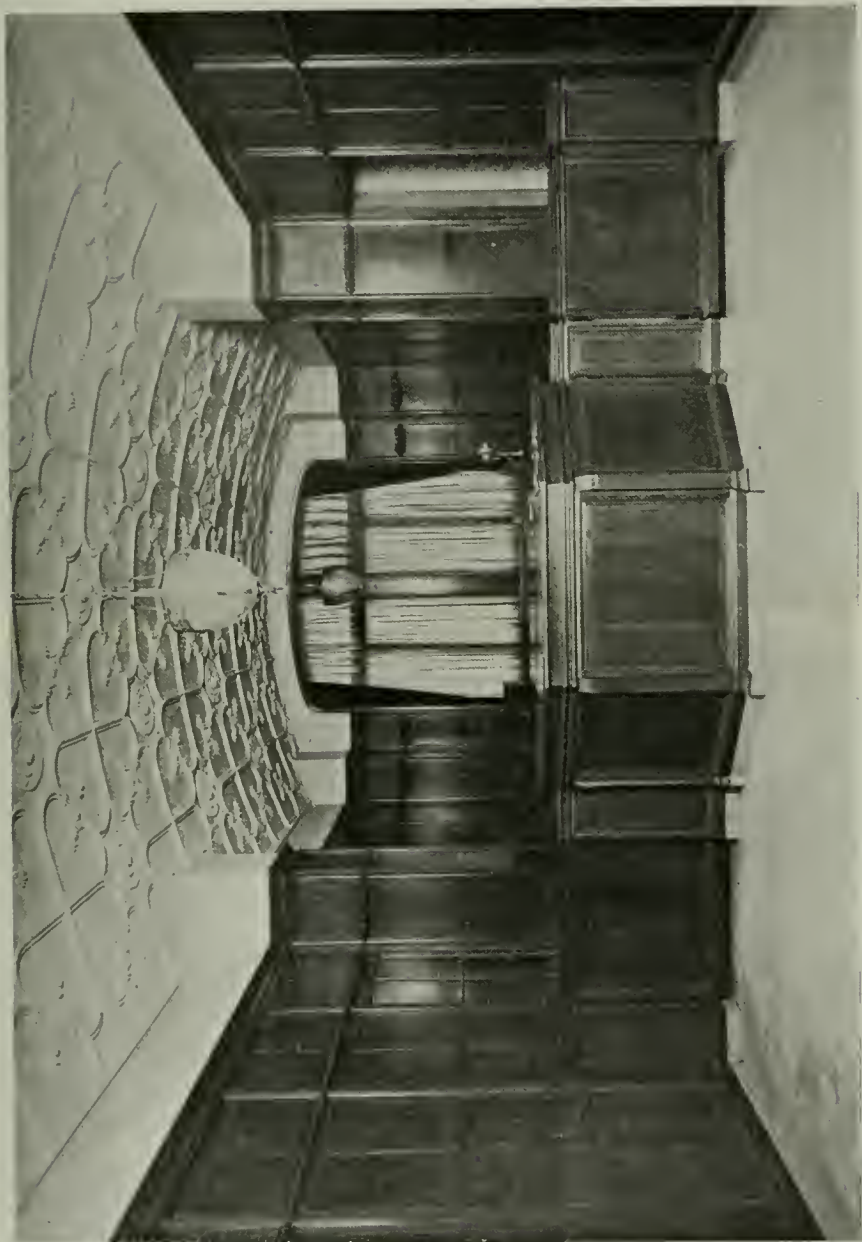

LOBBY, ROBERT DOLLAR BUILDING, SAN FRANCISCO
CHAS. W. McCALL,
ARCHITECT



PRIVATE OFFICES, ROBERT DOLLAR BUILDING, SAN FRANCISCO
CHAS. W. McCALL, ARCHITECT



PRIVATE OFFICES, ROBERT DOLLAR BUILDING, SAN FRANCISCO
CHAS. W. McCALL, ARCHITECT



GIRLS' REST ROOM, ROBERT DOLLAR BUILDING
SAN FRANCISCO. CHAS. W. McCALL, ARCHITECT



DIRECTORS' ROOM, ROBERT DOLLAR BUILDING
SAN FRANCISCO. CHAS. W. McCALL, ARCHITECT



MANTEL IN DIRECTORS' ROOM, ROBERT DOLLAR BUILDING,
SAN FRANCISCO.

CLAS. W. McCALL, ARCHITECT



CUSTOMERS' ROOM, ROBERT DOLLAR BUILDING, SAN FRANCISCO
CHAS. W. McCALL, ARCHITECT



CONCRETE HOUSE, VALLEY VIEW, N. J.



CONCRETE WINDOW FLOWER BOX



HOUSES BUILT OF Poured CONCRETE, VALLEY VIEW, N. J.

How One Big Eastern Industry Solved Its Housing Problem with Concrete

LIKE many other industrial concerns, the Ingersoll-Rand Co. at Phillipsburg, N. J., has for years been confronted with the problem of providing suitable homes for its employees and their families. The plant is located at the corporate limits of Phillipsburg. In the earlier period of its history a street car line was constructed from built-up portions of Phillipsburg to the plant site, for the special accommodation of the company's employees.

During the war rapid and extensive plant expansion caused the housing problem to become acute. The Ingersoll-Rand Co. soon realized that existing facilities and those which might be developed from outside sources were entirely inadequate to meet the emergency thus created. This emergency made evident, more than ever before had been realized, the vital importance of good housing on the morale, dependability, efficiency and good citizenship of labor. The company, therefore, determined not only to provide for an immediate need, but to attempt a solution of the housing problem from the standpoint of all of its fundamental requirements.

As a start, a tract of land was acquired east of the plant, and the Phillipsburg Development Corporation was organized, with Mr. Paul R. Smith, Architect and Town Planner, in charge, to formulate plans for and handle the entire project. The development which resulted is known as Valley View and presents not a temporary solution of a problem of the moment, but one worked out in minute detail and permanent in character.

In its study, made with a view to developing the plans for this project, the Phillipsburg Development Corporation realized that the employees of a large industrial concern for whom housing accommodations must be provided might naturally be divided into two general classes—first, the heads of departments, foremen and highly skilled mechanics, and second, the semi-skilled and unskilled labor.

It was evident that providing for the first group would not be a serious problem because the employees of the class mentioned constitute but a small fraction of a large plant's total and are usually better able financially to plan and provide

homes for themselves in accordance with their tastes or desires; but this does not mean that the latter class was not considered in the Phillipsburg development.

However, employees falling in the second group present a much more difficult problem. Usually they are not financially able to purchase homes costing more than a few thousand dollars. Also, terms of payment must be arranged on the basis of small monthly installments amounting to little more than rent. The period of purchase therefore covers a long term of years. It is obvious that however small monthly payments are, they must be large enough to include cost of maintenance, depreciation and insurance, as well as provide for a reduction of principal. Ultimate economy is paramount; yet because the houses must be the family home for many years, they must also be planned with a view to convenience, comfort and attractiveness. In short, the fundamental requirements of the ideal house for the industrial worker are, lowest possible first cost, comfort, convenience, attractiveness, freedom from maintenance charges, absence of depreciation and security against loss by fire or tornado.

The Phillipsburg Development Corporation realized that freedom from maintenance, absence of depreciation and security against loss from fire or obsolescence must be secured through inherent qualities of some construction material. Comfort, convenience and attractiveness are matters of design, setting, location and appointments. Lowest possible first cost, consistent with other requirements, can be realized only through some standardization, that is, by preserving a similarity of size and type of house that will permit of repeated duplication of construction operations.

As a study of the corporation's problem progressed, it became evident that concrete was the material having the possibilities of supplying all the fundamental requirements which have been realized at

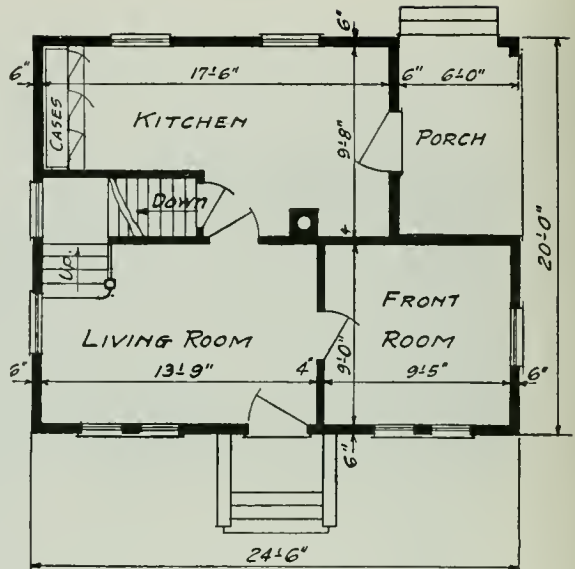

STANDARD FLOOR PLAN, CONCRETE HOUSE
Valley View, N. J.

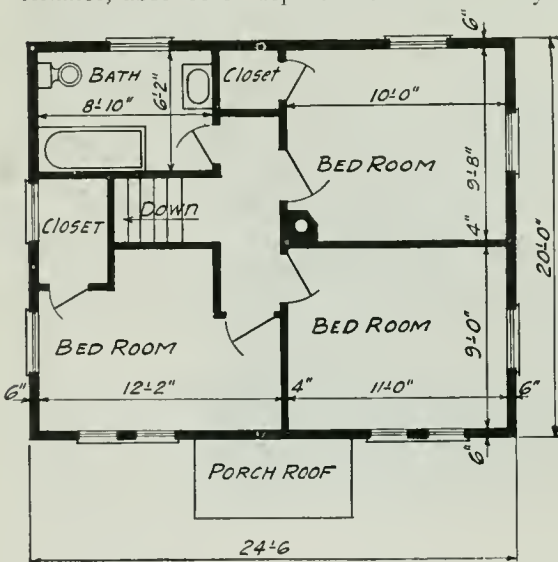

STANDARD FLOOR PLAN, CONCRETE HOUSE
Valley View, N. J.



INTERIOR, CONCRETE HOUSE, VALLEY VIEW, N. J.

Valley View. Comfort and convenience in these houses have been obtained by a commonsense study of the needs of the prospective occupants and by following well-known requirements of construction. Attractiveness was secured by finishing the houses in a variety of pleasing colors, by skillful arrangement and variation of their facing directions, and by giving each house enough grounds to provide for landscaped lawns, shrubbery, etc.

However, the ends attained at Valley View might not have been realized had there not been presented to the Phillipsburg Development Corporation a system of concrete construction that made it possible to reduce building costs to a standardized manufacturing basis. In this way, low first cost was obtained for houses inherently proof against depreciation, loss by fire or material damage from whatever cause.

The system adopted was one developed by Mr. C. H. Ingersoll of "dollar-watch" fame, after ideas advanced several years ago by Mr. Thomas A. Edison. The forms used are of wood and are set up for a complete house at one operation. The reinforcement, electric wiring, plumbing, and similar service installations are put in place, and then concrete is placed continuously from basement to roof.

Before a decision was reached as to the exact size and design for these houses very careful attention was given to determining what could be done to prevent an appearance of monotony that many people believe is unavoidable when a group of houses essentially all alike are built. The Valley View houses were designed with three different elevations, so that their facing directions could be varied and thus present different street entrances.

The tract of land was laid out with winding in-

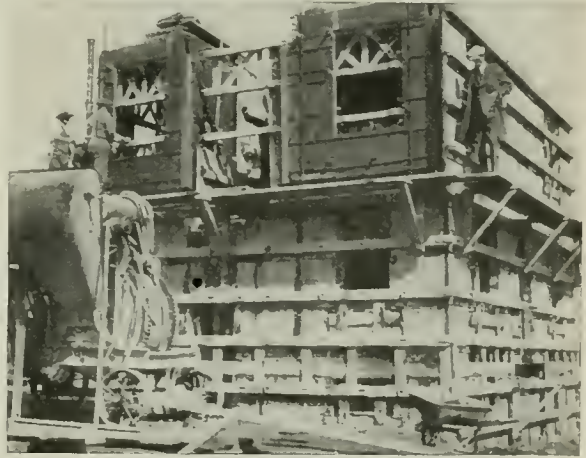

HOUSE IS CAST IN ONE CONTINUOUS OPERATION, FORMS BEING SET UP COMPLETE BEFORE CONCRETE IS POURED

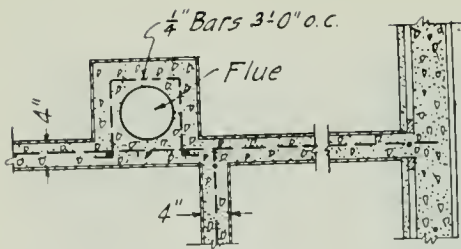

SECTION SHOWING WALL INTERSECTION

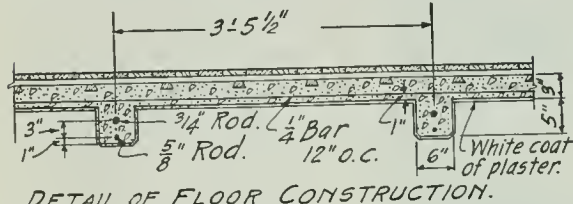

DETAIL OF FLOOR CONSTRUCTION.

The basement floor is first cast as a slab and 6 by 6-inch corner posts, story-high, are set up on wedge blocks. The trusses which support the forms are held to these posts by iron bands tightened by wedges. Concrete is cast for an entire house at the roof line and is raked out over the floor forms to the required thickness. Front and rear porch steps may be cast at the same time as the remainder of the house or may be cast separately.

Flues are lined with No. 26 gage black iron which also acts as inside forms. Wiring conduits, pipes for plumbing, etc., are all bent and cut on arrival at the work so that wiring and plumbing installations are reduced to simple standard operations.

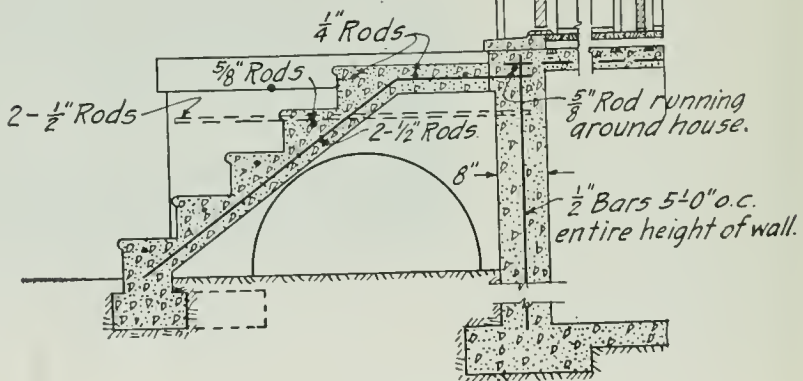
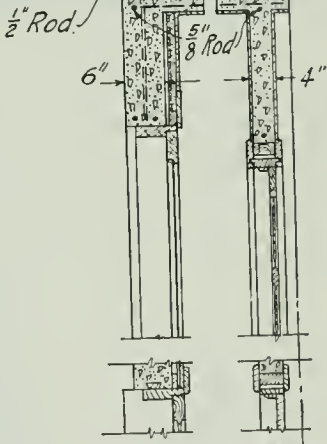
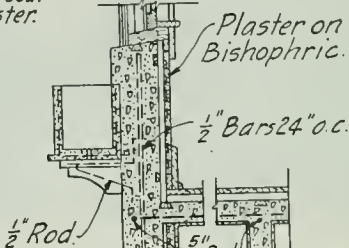
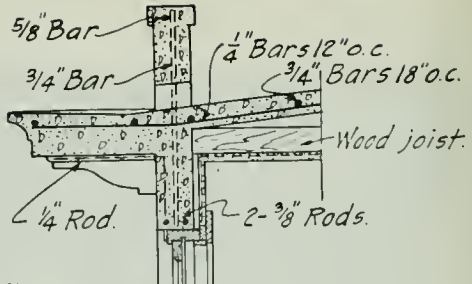

CROSS SECTION OF WALL.

stead of straight streets. The houses were set back from the sidewalk line and ample parking provided between sidewalk and street curb. Surface finish was varied by the use of several colors for the stucco coat, and window flower boxes with shrubbery in the yards, helped to make up the outstanding features of an exceedingly attractive housing development.

Careful estimates of cost showed that these houses compared favorably with either brick or frame construction, and that as the houses would be thoroughly fireproof, free from maintenance and depreciation and no insurance would be required, the ultimate economy of concrete was apparent.

Valley View homes are truly a standardized product. Four and six-room houses have been built, but as the six-room size has proved more popular, additions now being made to the development are six-room houses only. First and second floor plans of these are shown in illustrations.

The houses have full basements with pipeless heater, have modern plumbing and are lighted by electricity. In the kitchen there are a sink, laundry trays and kitchen cabinets.

Basement walls are 8 inches thick, and the first and second story walls, 6 inches thick, of 1:2:4 concrete. Floors are light beam and slab construction, resulting in a beamed ceiling effect. Floors are covered with wood flooring.

Exterior walls are floated with cement-mortar, then given a thin stucco finish applied with a coarse brush. White, buff and salmon are among the colors used to vary surface tone. Interior of outside walls is plastered on Bishopric board nailed to furring strips embedded in the concrete, so as to provide a 1-inch air space for insulation.

Roofs are reinforced concrete beam and slab construction. Insulation of the roof is obtained by suspending the ceiling on joists, thus providing an air space. The inside of parapet wall, top of cornice and roof surface are coated with waterproof paint.

The only wood in the houses is the floor covering, doors and door frames, window frames and sash, built-in kitchen cabinet and trim. Therefore, insur-

Standard wooden forms for these houses are constructed of 2-inch stock, crossed at right angles with best grade 7/8-inch lumber, creosoted and thoroughly painted. They are oiled before used and cleaned where necessary after use. The form members proper are supported by heavy wooden trusses by means of bolts passing from outside to inside with wooden washers for spacers between inside and outside form sections. The trusses are on the inside of the building proper and support the trussed floor beam forms which in turn carry the floor slab forms.

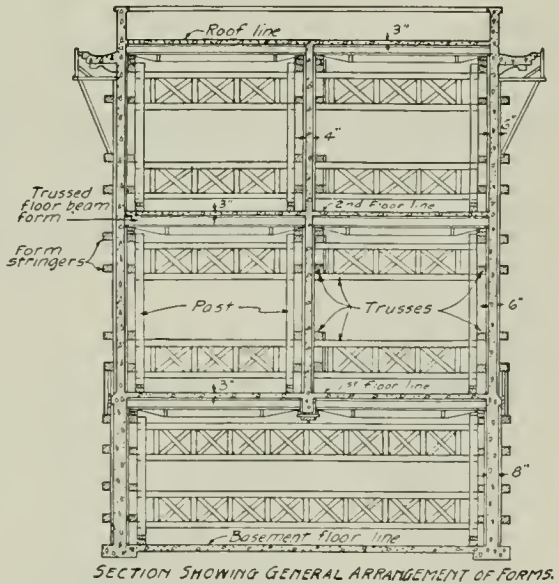
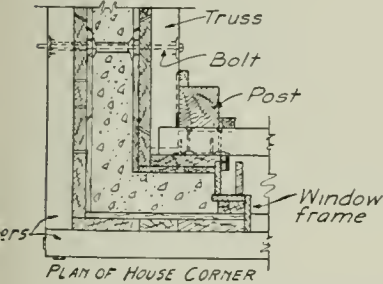

DETAILS OF INGERSOLL STANDARD FORMS

ance is saved, as the houses so nearly approach complete fireproofness as to make fire risk negligible.

These houses are sold for actual cost. In spite of the considerable increase in general building costs, duplication of operations and efficiency of crews on this work have so contributed to economy that these six-room houses are being produced and sold with the lot at \$3,550 each. This figure includes pipeless heaters, laundry tubs, kitchen cabinets and hot water boiler, also concrete walks laid to front and rear doors, and grading of the grounds.

The original selling plan contemplated a down payment of 10 per cent of the purchase price. In many cases, however, the intending purchaser is not able to make this payment and sale is made without down payment. If no down payment is made the monthly payment for the six-room house is \$21.39 and \$17.85 for the four-room houses. Complete cost of the latter type is \$2,750.

* * *

Wages Paid in London Building Trades During 700 Years

Wages have never decreased in a period of more than 700 years in the history of the building trade in London, except for very short periods, according to a London authority quoted in the New York Times.

Such a slight decrease occurred between 1292 and 1324, following the completion of Westminster Abbey, Westminster Palace and extensive alterations on the Tower of London.

The following table is given by this authority, of wages paid per day in building trades in London, the penny being calculated at two cents:

Year	Wages Per Day	Year	Wages Per Day
1250.....	.03½	1650.....	.28
1300.....	.05	1700.....	.40
1350.....	.06	1750.....	.40
1400.....	.06	1800.....	.58
1450.....	.08	1850.....	.72
1500.....	.08	1914.....	\$1.60
1550.....	.10	1920.....	5.00
1600.....	.16		

* * *

How to Arrive at the Amount of Oak Flooring Required

To cover a certain space, figure the number of square feet, which means the width multiplied by the length, for instance, a room 12 feet wide by 15 feet long would contain twelve times fifteen or 180 square feet. Add to the square feet of surface to be covered the following percentages:

50 per cent for.....	13/16-inch by 1½-inch
37½ per cent for.....	13/16-inch by 2-inch
33½ per cent for.....	13/16-inch by 2¼-inch
33⅓ per cent for.....	¾-inch by 1½-inch
25 per cent for.....	¾-inch by 2-inch

The above figures are based on laying flooring straight across the room. Where there are bay windows, hearths and other projections, allowance should be made for additional flooring.

* * *

Raisins

You've heard about the raisin
 With the kick of 10 per cent,
 But the raisin with the wallop
 Is the raisin' of the rent.

—Columbus Dispatch.

Awards Made in Small House Competition

ARCHITECTS represented and interested in the national "Small House Competition" displayed great interest in the "Own Your Home" Exposition held in Chicago, March 26 to April 2 and in New York, April 16-20, according to Mr. Henry K. Holzman of Chicago, president of the Illinois Chapter of the American Institute of Architects.

The "Small House Competition," conducted in conjunction with these expositions, closed February 7. Three four-room house designs, two of which were submitted by Mr. Louis Justement, Washington, D. C., and the third by Messrs. Edger and Vernon Solomonsky, New York City, were selected by the jury of awards as first prize-winners. The winning designs are in frame, brick and back plastered metal lathe and stucco. The first prize was \$500.

More than one thousand small house designs were passed upon during the two-day sessions of the jurors at the Art Institute in Chicago, and the announcement of winners was made February 9. Fifty of the best designs, for which \$15,000 in prizes were awarded, were exhibited at the Chicago "Own Your Home" Exposition.

The designs also were displayed during the third annual "Own Your Home" Exposition in New York. Real estate boards, including those in Philadelphia and New Haven, also will exhibit them. In both Chicago and New York Department stores have been granted permission to construct prize winning designs, for exhibit purposes.

Designs were submitted for four, five and six-room houses. The cost of construction of any of the first prize winning houses, according to Mr. Holzman, will run from \$6,000 to \$6,800. This estimate does not include the cost of the building lot. The cost of construction of other designs given prizes and honorable mention in the five-room classes, will not in any instance exceed \$10,000.

Mr. Charles H. Hammond, the Chicago architect on the jury, termed the house designs the best he ever had seen submitted in a prize contest. "We are delighted with the results," he said. "The prize winners are remarkable both for their architectural attractiveness and for the splendid arrangement of their rooms."

"Realizing that the majority of small houses are not designed by the most competent architects, and that small plans are not usually profitable work for established architects," according to Mr. Holzman, "the 'small house competition' was hit upon as the method of enlisting the nation's best architectural skill and minds in designing plans for economically constructed beautiful small homes."

"The entire program seems to have met with a very agreeable and very general response throughout the country," continued Mr. Holzman. "I have received among many letters, one of commendation from the president of the American Institute of Architects."

The designs which won prizes and honorable mention, as well as a number of designs set aside by jurors as especially meritorious, will be incorporated in book form. Detailed working drawings and complete specifications also will be available so that prospective home builders may obtain them at a cost not to exceed \$25.

The members of the jury of award were: Architects—Messrs. C. H. Hammond, Chicago; Edwin H. Howitt, Minneapolis, Minn.; E. J. Russell, St. Louis, Mo.; and Hal F. Heintz, Atland & Dwight, Jas. Baum, all of New York; and the following builders: Messrs. E. W. Lane, H. G. Zander, and Bartholomew O'Tolle, all of Chicago.

The only prize winner from the Pacific Coast was the firm of Montgomery & Nibecker of Los Angeles.

Fifty-fourth Institute Convention in May

THE Fifty-fourth Convention of the American Institute of Architects will be held in Washington, D. C., May 11, 12 and 13. Among the subjects that will come up for discussion will be the matter of competition practice.

At the Convention of May, 1920, the following clause was offered as an addition to the Competition Code:

"The Institute recognizes the right of the owner to purchase unlimited professional service on a basis of adequate remuneration and control. No competition, therefore, shall be held to exist where two or more architects prepare sketches at the same time and in the same manner for the same project, provided the following conditions are complied with:

"The owner shall employ a professional advisor. He shall be an architect of the highest standing, and his selection shall be the owner's first step. The professional advisor shall see that each architect employed be informed as to all the others, and the remuneration for the preliminary service so rendered be uniform for all and agreed upon by the owner, and that all the architects so employed are satisfactory and adequate.

"The professional advisor shall see that all drawings requested of the architects be on the same basis and presented in the same manner, and he shall act in an advisory capacity only, the owner not being obliged to accept the recommendation of the advisor in making the final selection."

The action taken by the Convention was to direct that the question be referred to the Chapters for thorough consideration in order that the Fifty-fourth Convention may take definite action in the light of fully ascertained sentiment of the Institute. Such reference was made to the Chapters in a special communication early in October.

Another subject for discussion at the Convention will be New Registration Laws.

There are now twenty states which have registration or license laws for architects. Every year additional states are added to the list, and in a relatively short time practically all states will have such laws. The Institute, by action of three conventions, has approved the principle of registration, and has promulgated a model form of registration law which has been used successfully in various states.

The Chapters of the Institute have been formally requested to act upon two proposed changes in the Schedule of Charges. One provides for an increase in the present suggested minimum charge of 6 per cent; and the other proposes a complete revision of the document in order to make effective several changes.

The Board is of the opinion that the present method of payment, prescribed in Article 9, involves hardships to the architect and is undesirable, and that some method should be devised under which the architect shall be paid by the month, from the beginning of his work, such payments to be so arranged as to conform, in total, to the payments now called for.

* * *

Oppose Wage Cuts

THE Executive Council of the Building Trades Department of the American Federation of Labor went on record recently as opposed to any wage reductions in the building trades at this time. The members pointed out that while the wholesale prices of food, clothing, and fuel had dropped, the decreases had not been put into effect by the retailers.

The council adopted a resolution advocating the repeal of the income tax on proceeds from mortgages which do not exceed \$40,000, in order to make it easier to obtain money for building operations.

Building Loans at Six Per Cent

AN Eastern banking house has undertaken to relieve the housing shortage by offering to finance home building at 6 per cent and a reasonable underwriting charge. The example set by this firm may well be followed by other financial institutions. It is not extravagant risk, but sound business sense. The following is taken from one of the advertisements inserted in a Chicago newspaper by the bank in question:

In view of the housing shortage that exists in Chicago and elsewhere—and the vital need of relieving this shortage in the interest of public welfare—S. W. Straus & Co. will make loans at six per cent in the form of first mortgage bond issues to assist in financing the construction of modern apartment buildings in amounts of \$200,000 and upward. Our service charge to the borrower, commonly called commission or discount, will be only sufficient to offset the expense of distribution.

This policy is put into effect because there exists a menace to public health, morals, and national security, growing out of the existing lack of sufficient and proper homes for people to live in. It is our contribution to the cause of humanity—our response to the call of patriotic duty.

We, therefore, invite those who have deferred building projects for one reason or another to avail themselves of the service we are ready and most eager to give. Architects, engineers and contractors are urged to advise clients, who have been contemplating building, that all meritorious housing projects conforming to our requirements and safeguards can be financed immediately through this house.

Building costs have receded from 15 per cent to 25 per cent below the peak of 1920. Many commodities have been reduced as much as they reasonably can be, and prices of some materials, which have gone under cost of replacement, will rise again when demand increases.

Build now is our advice, it is economical, safe, and profitable.

The underlying cause of the housing shortage and the paralysis of the construction industry has not been the high cost of labor and materials—although, to some extent, they may have been contributing factors—but the lack of sufficient capital to finance construction. Rents are high because supply is short and demand is great—and rents will remain high until supply is equal to demand. In other words, rents will not come down until buildings go up. Buildings cannot go up until they are financed, and they will not be financed until the money is provided. This is the whole story in a nutshell.

Plainly, the logic of the situation is this: The public should, for the time being at least, invest its savings and surplus in the safe real estate mortgage or mortgage bond, or it will continue to suffer from lack of homes and constantly rising rents. Those who need a home and are financially able should build for themselves. Those who are fortunate enough to have a comfortable home should lend their savings so that others not so happily situated may have a place to live.

There is something else to be thought of in this connection. Stagnation of the building industry has prevented the proper flow of general business. Restore building activities by helping to finance them, and there will be an immediate revival of every industry in the land. Thousands of men and women, now employed, will go back to the shoe factories and the textile mills. Railroads will be given freight to haul from forests, mills and mines, and money will be placed in the hands of the consumer to buy the products of the farm now locked up in warehouses and granaries because there is no demand. Every human activity will be benefited and prosperity will return almost overnight.

We believe that money for building should be borrowed at six per cent. That is all a mortgagor should be asked to pay.

Our message to the builder is:

If your project is sound, we will lend you the money to finance it at six per cent.

Our message to the investor is:

If you are looking for safety—and safety is what every man and woman wants in the investment of their savings—then the question of high yield should not take precedence over that which time and tried judgment have taught the experienced investment bankers.

* * *

It Probably Hadn't

"I refused this house plan six weeks ago," said the owner to the architect. "Why do you again submit it?"

"I thought perhaps your taste had improved by this time," replied the architect with a gleam of satisfaction in his eye.—Exchange.

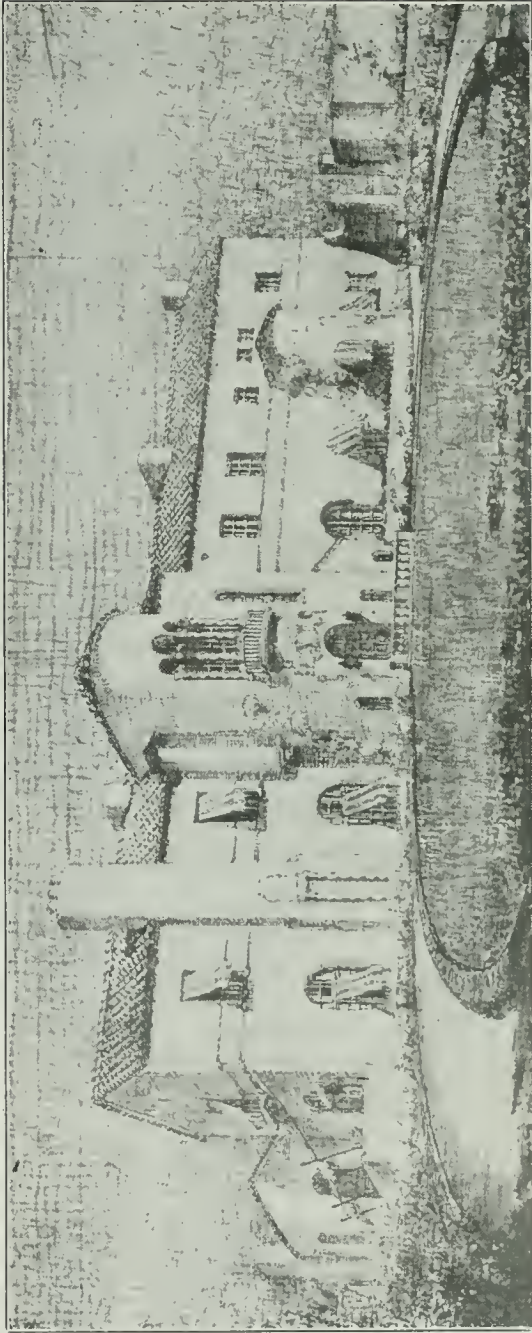

RESIDENCE FOR MR. W. P. HANSON, FLINTRIDGE,
LOS ANGELES. HARWOOD HEWITT, ARCHITECT

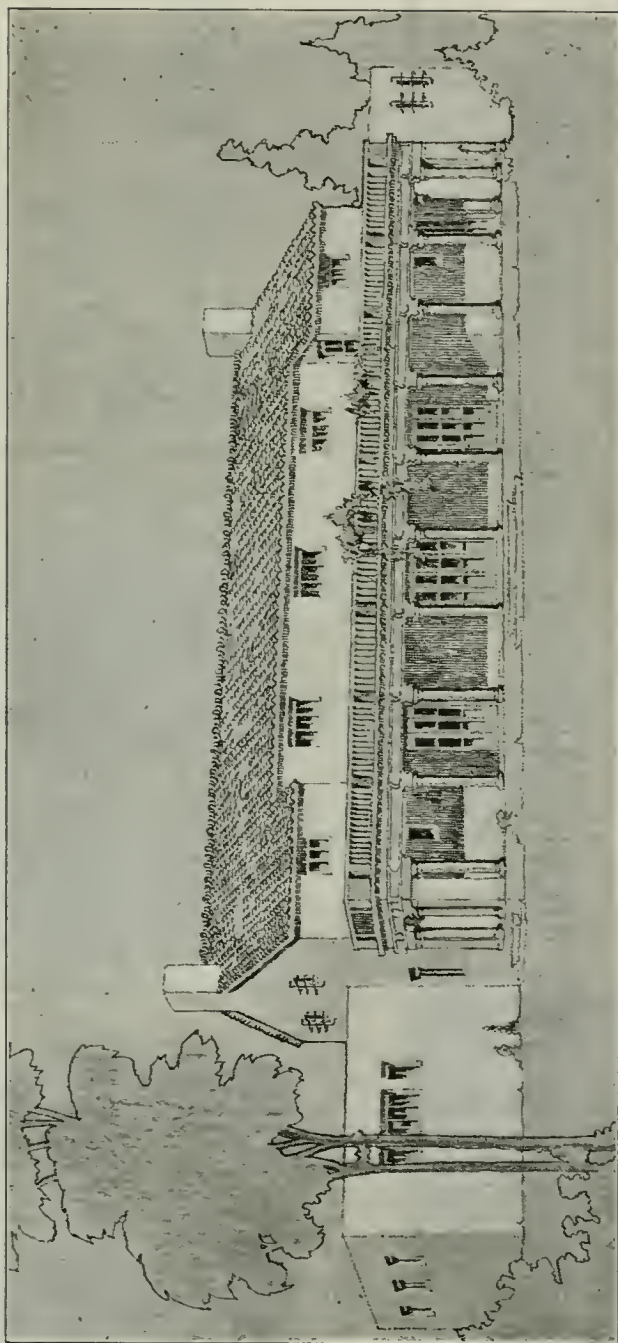

(Courtesy Southwest Builder and Contractor)

CLUBHOUSE FOR LOS ANGELES TENNIS CLUB,
LOS ANGELES. HUNT & BURNS, ARCHITECTS

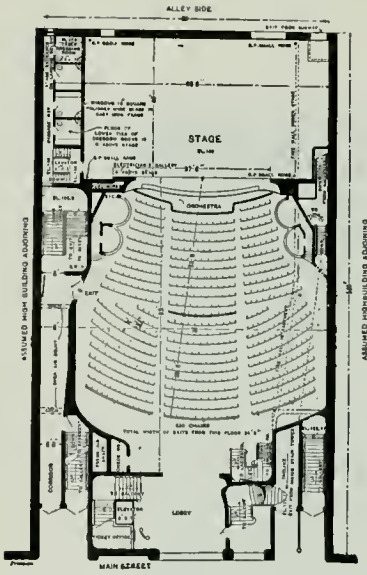

Freeman's suggested plan of aisles and exits, showing exit under stage to alley and incline through basement to street in front.

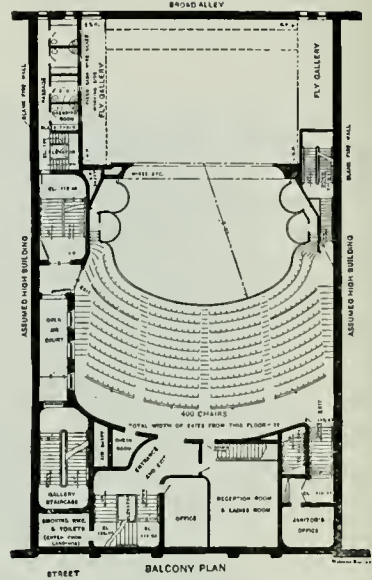

Freeman's suggested balcony stairs, etc.

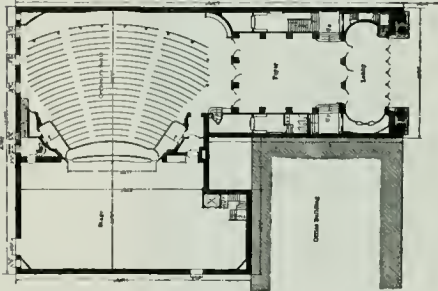

Splendid arrangement of Colonial Theatre, Chicago, showing lobby and foyer at right angles with auditorium. Stage, 50 ft. by 110 ft.; arch, 30 ft. high by 41 ft. wide.



Admirable arrangement of loges and balcony front



Novel ceiling lighting and triple draped stage arches.

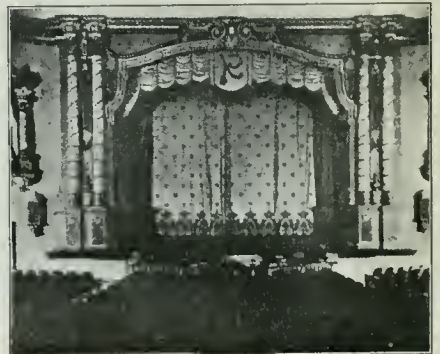

Picture Theatre draperies and tile curtain which can be operated from the picture booth if desired.

The Planning of Theatres and Auditoriums

Building Laws in Some California Cities Declared Out-of-Date, Inadequate and Practically Useless

THIRD PAPER*

By EDWIN H. FLAGG

IN many theatres the most often used drops and the border lights are operated by endless lines from the stage.

An example of this arrangement, only that in this case all of the drops and hanging stuff are operated from the stage, is in the new Keith Theatre, Syracuse, N. Y. Here we have an ideally equipped and operated vaudeville stage. A similar, though due to several additions incorporated making it a superior method, embodying all the advantages of this one, was devised by J. R. Clancy and Claude Hagen many years ago.

All of these are only amplifications of the old endless line counterweight systems long in use in most Masonic stages and more recently in the Pantages circuit of theatres.

For about fifteen years Alexander Pantages has been the pioneer and insistent advocate of this system in large theatres. He stood practically alone, even being opposed by most of his own house managers and stage crews. Now the latest and finest New York state house has adopted it.

There is much to be said in favor of and against the "no fly-gallery idea" and every angle of the situation should be gone over in advance with a competent authority before a decision is made in the matter.

There should be no windows on a stage.

If the theatre is on a corner location, the stage door should be on the side wall near the back wall, never if possible on the back wall, or if it must be in the back wall it must be at either the right or left of the stage, and not in the center. It is not necessary for a stage door to be as wide as is commonly supposed, for it must be remembered that no traveling piece of scenery is any larger than the door of a baggage car.

However, due to traveling shows playing either a different city every night, or even on long stands, changing from one city to another between approximately midnight and noon the next day, or in the case of stock theatres or picture houses where the play has to be changed between the same hours, it is almost imperative that the transfer wagons can come up directly to the stage door.

If not on a corner a ten-foot passage way is necessary from the street to the stage door, and this can be used as an emergency exit from the auditorium.

If the location is wide enough the dressing rooms may be placed at the side walls, in which case the same stairs may be used to get to the fly-gallery. If not, there should be an iron ladder extending from the stage to and through the fly floor on up to the gridiron, located preferably near the switchboard. A dozen or more dressing rooms about 6 feet by 8 feet should be provided, and two or more chorus rooms about three or four times as large. A property room at least 12 feet by 18 feet, easily accessible and adjoining the stage. A room for the stage employees, equipped with lockers around the sides and a similar room for the members of the orchestra. Owing to the growing difficulty in finding accommodations for them, and the usual unsanitary conditions of their temporary quarters, it is

*Mr. Flagg's first article appeared in the October, 1920, Architect and Engineer, and his second paper was published in the January, 1921, issue.



SMOKE VENT. MONITOR TYPE
SIDE ELEVATION

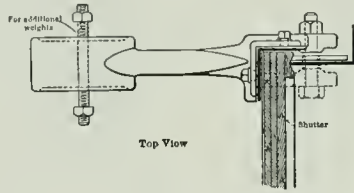

Top View

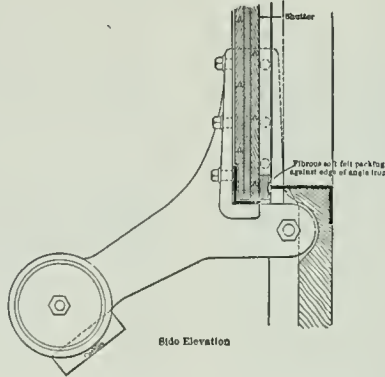

Side Elevation

Detail of weight for shutter of smoke vent.
Monitor type.

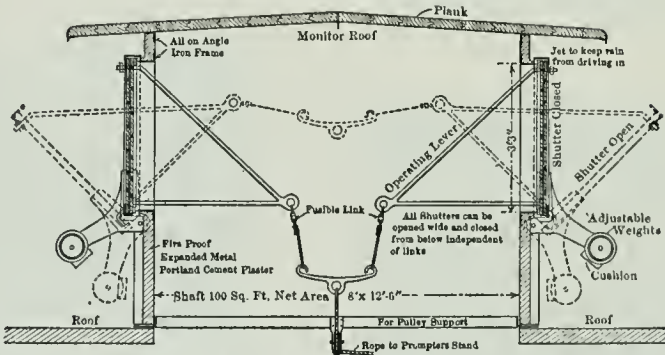

SMOKE VENT. MONITOR TYPE
VERTICAL SECTION

SCALE OF FEET
0 1 2 3

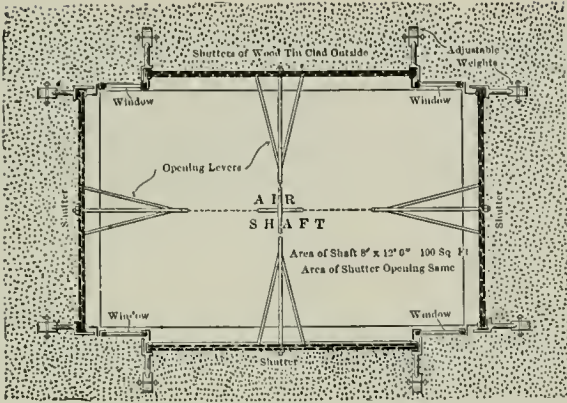

Smoke Vent, Monitor Type, Horizontal Section.

advisable to provide adequate animal rooms in vaudeville theatres for all acts employing trained animals.

Heating, ventilating and organ accommodations are taken care of elsewhere, in these articles.

All scenery is either the drops mentioned above called "hanging stuff" or framed pieces that stand on the stage called "set stuff" or sometimes "flat stuff."

White or sugar pine is the lumber used almost exclusively in scenery construction owing to its relative lightness and strength and comparative durability.

The frames, regardless as to their size, are usually composed of battens $2\frac{3}{4}$ " or 3" wide by $\frac{7}{8}$ " thick, in any length one way by not to exceed 5' 10" the other, or multiples hinged together, screen wise, the whole width when folded not wider than 5' 10". This is so that they may be transported in a baggage car, for scenery, whether it ever leaves the theatre or not, is almost universally made in units that could be so transported.

The usual height of interior scenes is either 10-12-14 or 16 feet, while exterior wings usually run two to four feet higher.

Safety Precautions

It will be noticed that the composition of this scenery, which more or less fills the stage, is of the utmost combustibility, composed of cotton and match-wood. And it is strewn around the stage or suspended above it in the chimney-like "flies" with just enough space between each drop to make a perfect draft.

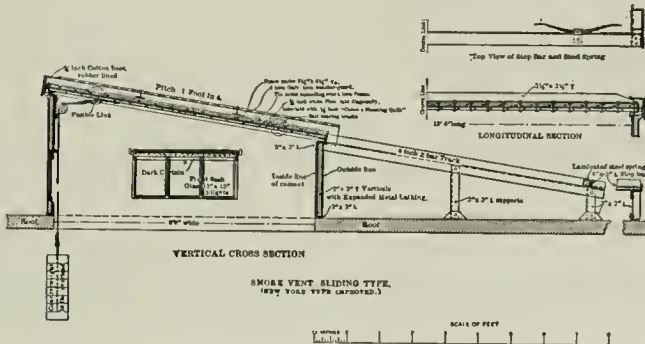

SMOKE VENT SLIDING TYPE
(SEE NOTE 1978 ENLARGED)



If we take the nearest thing we have to which we can compare a modern theatre, stage and fly-loft, we have a very small living room, a very large fireplace or mantel, the hearth, and above it the flue or chimney. The hearth represents the stage; the mantel the proscenium arch; the room the auditorium, and the flue the vent over the gridiron in the roof that carries off the smoke and poisonous gases generated by burning wood, cotton, scenery paint, and what is worst of all, the useless and totally ineffective so-called fireproof solutions with which some cities compel managers to saturate their scenery.

All of these solutions have been, after exhaustive tests, proven to either do one, or several, or all of the following:

Render the scenery blotchy;

Destroy the colors;

Shorten the life of the scenery;

Draw and hold dampness;

Cause useless annoyance and expense;

Have practically no appreciable effect in retarding combustion;

Generate in conjunction with the cloth and burning paint a more deadly gas than any possible benefit could compensate.

Let us take the above example of the room and fireplace, and say we fill the hearth with a proportionate amount of miniature scenes; reduce the size of the flue to the size of the ordinary theatre vent, proportionately, and set fire to it.

What happens is that the fire consumes so quickly that the vent cannot accommodate the expansion of the air which is suddenly forced out into the room, and although it does not burn, it kills, suffocates, those in the room.

This is exactly what has occurred in not only the Iroquois Theatre fire in Chicago, where over five hundred people lost their lives, but in practically every great theatre fire in history.

I know of a recently completed very elaborate and ornate theatre costing over two hundred thousand dollars in one of the larger California cities, in which, if a fire ever gets a good start, the loss of life will be as great or greater than in the Iroquois fire.

I state this advisedly and after having investigated the records of every theatre fire of which there is any history for the past hundred years.

After this theatre was built when it was first called to my attention, I explained the defect to the architect, who seemed very much concerned and stated that he would see that it was immediately remedied. Some months later, although they were remodeling other portions of it to meet the requirements of the lessee, I was informed that owing to the massive and costly construction of the roof over the stage it would cost too much to permit the correction, and besides, "No one had noticed or wanted the change except myself."

The theatre building and fire laws in that city are ridiculously and uselessly stringent in most ways and obligingly lax in others.

This fault applies to laws of most cities pertaining to the prevention of fire and safety of life in theatres, but a certain southern city has the most out-of-date, inadequate, useless and unnecessarily expensive theatre building laws in existence.

These, I have been informed, were compiled by architects and engineers from time to time for their own benefit, and without ever consulting or going by the experience of experts, nor does it appear that any portion was ever taken out even when made obsolete by some subsequent clause or newly created condition.

By contrast, the City of San Francisco seems to have the most perfect laws and regulations of this kind, working out even better than those of either New York or Chicago.

But without suggesting a model ordinance I would refer you to certain experiments carried on years ago by the authorities in the cities of Berlin, London, Vienna and Paris, and the conclusions drawn therefrom, after the burning of model theatres built to scale and equipped with combustibles similar to those found in the ordinary theatre.

The Austrian Society of Engineers made an investigation after the burning of the Ring Theatre in Vienna, and the results of this were republished after the Iroquois fire in Chicago.

Mr. John R. Freeman, foremost authority on fire prevention, and then president of the American Society of Engineers, states, "In the course of my own studies of the theatre and auditorium problem, I have seen almost everywhere conditions affecting the safety of life that would not be tolerated by the managers of our best industrial works, and all from simple failure to know or give attention."

The same authority states, "In Chicago within a few months after the appalling disaster at the Iroquois Theatre, the aldermen rescinded the rule calling for automatic sprinklers over the stage and rigging lofts of the theatres because the managers believed they 'wouldn't do any good.' Every factory manager will admit the absurdity of such a statement."

We cannot leave it to the underwriter to make the theatre safe against fire.

The able president of one of the largest insurance companies has said to me, "As an individual, I would be very glad to see theatres safe to the public which patronize them, but as an underwriter I charge for the hazard as I find it, and need not care particularly whether the rate is one per cent or five per cent."

We must bear in mind that a comparison of insurance rates, while an excellent guide, is not a complete or accurate basis for a comparison of safety of life in different theatres, for the questions of accident or death to audience or actors are settled within the first five minutes after fire breaks out, while the per cent of damage that concerns the fire underwriter may be in suspense for an hour or more.

Mr. E. O. Sachs published in London in 1898 a book of a thousand theatre fires. This apparently was a continuation of a previous treatise published by a German engineer of Hamburg and Vienna, who began in 1869 to collect statistics of theatre fires and who, up to the time of his death, had collected records of over 500.

As Freeman says, "These records are impressive, but they teach far less than a full study of a few of the notable examples."

Briefly, going back to the chimney simile, it is realized that it practically costs no more to construct a fly-loft vent that, with regard to smoke outlet, is exactly the same as a chimney, viz., making the flue one-tenth the area of the hearth. This is the old London rule in theatre construction, which was evidently derived from the fireplace precedent, and this rule proven adequate was adapted by the larger American cities, Los Angeles being one of the exceptions. Some cities go further than one-tenth and make it one-eighth.

The next thing is the adoption of the most practically controlled opening and cover to fit over this outlet. It must be fitted snugly to keep the cold and water out and heat in, as desired. Further, it must be impervious to rust, or piles of snow resting on or against it, or from the temptations

of janitors to render it useless by filling in with rags to keep heat in, as has been done.

There are only two acceptable designs in use, the sliding by gravity, loose trap door type, running on a track, and the counter-weighted out-falling hinged doors, monitor type, which are really more positively acting. [See illustrations on page 92].

These are each controlled by fusible links melting under a certain heat, and in addition the counter-weighted outfall doors have the advantage of being operated at will from the switchboard for ventilation if desired or in connection with a firedrill. These openings can be fitted tighter and have proven infallible in every test.

Although the trap-door type is the one in general use in New York, Chicago and San Francisco, as the monitor type has advantages over the other, it is more advisable to accept the best. Neither design has any patentable features on account of the utter simplicity and commonly used principles.

Another item of the utmost importance and ultimate economy in insurance premiums, to say nothing of the saving of life and the revenue derived from continuous use of the building, is the proper equipping of the stage with sprinklers.

These should be installed on eight-foot centers over the gridiron, and staggered under it, and under the fly-floors, but not over any fusible links.

There have been many reported instances of fires that have developed being extinguished by sprinklers before the arrival of apparatus, five or ten minutes later. One instance of a fire starting in a cloth border, between acts, being extinguished with hardly any appreciable damage nor the audience knowing anything about it. In the absence of sprinklers this would have unquestionably proven not only a disastrous fire and caused a considerable loss of property, but leaving out the possible loss of life due to either the fire itself or attendant panic, but the loss of time to the theatrical company playing the house and the loss of revenue to the theatre itself due to closing for repairs would have been more for that one item than the entire first cost of installing the automatic sprinklers.

* * *

Says a \$1,150 House Costs \$9,000 in England

A few months ago there were certain common labor difficulties in the United States. The following is from a contractor in England:

"A long article could be written regarding the troubles we are up against. The ex-soldiers want special jobs, most of them are dead against doing any manual labor, and the union men are bleeding the contractors white, by doing two hours work in an eight-hour day, thinking this will prevent unemployment for them.

"Again, money will hardly buy materials for building; we have to graft, after paying for it, to get delivery.

"The result is that a residence that cost \$1,150 before the war, costs up to \$9,000 now. Hence, our big housing schemes are flickering out."—Concrete.

* * *

The Explanation

As Chicago sees it, the housing shortage is due to strikes, lockouts, high wages, high taxes, high rates of interest, high freight charges and lack of transportation facilities. Is that all?—Boston Transcript.



PIEDRA ROCK COMPANY'S PLANT

General view, showing storage piles containing 100,000 tons of crushed rock available for immediate shipment. This is in addition to the plant's daily output of 3,000 tons.

Record California Quarry Blast

ON March 20, 1921, the country 24 miles north of Fresno, Fresno county, California, was shaken by a dynamite blast that rent in myriad pieces of rock a young mountain 150 feet high and 500 feet wide. Engineers and contractors who witnessed the blast say it was the greatest quarry explosion on record in California. Some idea of its magnitude may be had from the statement that 45 tons (two car loads) of dynamite were used and when the mass of rock and stone lifted into the air by the explosion had fallen back to terra firma, the quarry floor was found to be covered with more than 400,000 tons of rock.

Curious sight-seers came in automobiles for miles around and an hour before the time set for the explosion there were several thousand automobiles parked within view of the mountain of rock. Blasts from a steam-shovel engine warned the spectators that the explosion was about to take place. The quarry is the property of the Piedra Rock Company whose general offices are in the Call building, San Francisco, the president of the company being Mr. F. N. Woods, Jr. The company's Fresno office is in the Mason building and the manager there is Mr. A. R. Kerstetter.

Many pictures of the blast were taken by three different film concerns. The pictures will be shown in the leading theatres throughout the country as an engineering and construction event of unusual interest in California.

The plant of the Piedra Rock Company has a capacity of 3,000 tons of crushed rock per day, is electrically operated and is equipped with the latest devices for producing uniformly graded products.



PIEDRA ROCK COMPANY'S PLANT

Close-up of quarry face, showing No. 70 Bucyrus steam shovel loading train enroute to crusher.



PIEDRA ROCK COMPANY'S PLANT

View of quarry face just before the blast.



PIEDRA ROCK COMPANY'S PLANT
After the blast—400,000 tons of rock shattered.



PIEDRA ROCK COMPANY'S PLANT
Gyratory crusher into which a carload of rock is dumped and quickly reduced to crushed stone.

In conveying the rock to the crusher plant a series of mechanical operations are employed. The virgin rock is shattered by dynamite and two No. 70 Bucyrus steam shovels with two and one-half yard dippers are employed to pick up the rock and load it into quarry cars which are relayed to the plant in three trains of ten cars each on a narrow gauge track and delivered to the crushers.

* * *

Recent Tendencies in School Architecture

GROWTH in school architecture is coincident with and almost entirely the result of growth in educational theory and practice. The older school buildings of the United States, which can be easily and accurately placed so far as the date of their erection is concerned, show very clearly the simple, stern type of teaching the three R's which prevailed. In recent years the enrichment of courses of study and the adaptation of buildings to varying theories in management, health and safety promotion are no less a reflection of present educational achievements and shortcomings.

Two types of schools have made the greatest apparent progress in the past year. These are the junior high school and the rural high school. It would be inaccurate to say that either the buildings as types or the schools as distinct forms of organization, have been other than the product of slow growth during the past ten years. But in the number of buildings erected during the past year these schools have been noteworthy as showing the greatest departure from the conventional and purely scholastic type and the greatest adaptation to new forms of educational effort.

Just as the intermediate school has the prevocational element uppermost in its curriculum, so the arrangement of workrooms and shops has become the most significant feature of these new buildings. The tendency is decidedly in the direction of increasing the number and variety of shops, but the planners seem to realize in the movable partitions and the general interchangeability of use that practice has not been stabilized and that flexibility is most desirable.

In general, the newest junior high schools recognize the youthfulness of the pupils more accurately than those of three or four years ago. Features related to administration and the movement of classes typical of the senior high school are being eliminated so that the control is more closely in the hands of classroom teachers with whom the children remain at least several periods each day. The two-story building without basement appears most frequently among the junior high schools erected last year and projected for 1920. The block type of plan seems to be growing in favor but there seems to be no warrant for the tendency away from the open plan except the desire for economy in ground space.

The rural high school of the present is more nearly a community school than is the large city school. The best examples are remarkably inclusive and complete in the facilities they afford for academic, home-making, science, agricultural, health and farm mechanics instruction. The refinements of plan and the adaptation to double uses are indicative of close study and a thorough understanding of school practice. The greatest shortcoming of rural high schools is the lack of good exterior design. The monotonous, box-like effect of flat roofs and the ugly elevations must be relieved by well designed features in the shape of entrance doors and modest ornament. The cost will be insignificant as compared to the attractiveness which the building will gain as the community center.

The best element of the newest rural high schools is the assembly room, which is being cleverly planned for use as a meeting place, gymnasium, dining

room and theater. Notably in Iowa, there have been built in the last year a large number of schools that are adaptable to every ordinary community need from a farm tractor demonstration to a motion picture entertainment.

The grade school building has, in the last year or two, shown less improvement than any other type. The reason is to be found in the fact that our schoolmen have been self-satisfied with, if not neglectful of, the primary school. While much has been said about the socialized recitation, practically nothing has been done to adapt schoolrooms especially to this kind of class activity.

Cleveland stands out from among the large cities in its development of the one-story, corridorless school as a distinct contribution to the development of elementary schoolhouse type. Mr. McCornack has proven that play courts in grade schools are not noisy disturbers of class-work and has shown that we have not yet reached a limit in adapting the grade schoolhouse to the most varied educational and neighborhood uses. In New York City, Mr. C. B. J. Snyder's newest grade school buildings stand in a class by themselves for utility and economy of plan. They are community and platoon schools that make the oldest schoolhouse with classrooms only look wasteful.

The greatest present need of school designers is a simple, workable scheme for determining the size of a high school for a given number of students. For the grades, such a scheme is superfluous, but for the high schools and the junoir high it is a vital need. The checking scales evolved thus far by Mr. Cooper's committee on standardization, are wholly inadequate for creative work because they constitute only a test of the use or waste of space in comparison with existing good buildings. There is an immediate need for a series of rules that will aid in determining the number of classrooms, laboratories, shops, etc., for a given number of students on a most economic basis. School Board Journal.

* * *

Tax Exemption on Homes

Tax exemption for all new dwellings for a period of at least fifteen years as a means of stimulating building was advocated by Mr. Lawson Purdy, former president of the New York City Board of Trade and Exemptions, in an address before the Housing Conference called by the Chamber of Commerce of the United States at Washington recently. Such an exemption would be a substantial inducement to builders, Mr. Purdy said, adding that it was fully warranted by the present shortage. He advocated that it should apply to all homes built in the next three years.

Remission of taxes on new construction could not be considered a discrimination against owners of existing property, Mr. Purdy declared, in view of the fact that construction costs are now 100 per cent above normal.

Expansion of private building association operations throughout the country as a means of increasing opportunities for home building was advocated by Mr. K. V. Haymaker, former financial adviser to the United States Housing Corporation. Mr. Haymaker urged trade and business associations to aid in diverting capital into building associations and also advocated establishment of the proposed federal home loan banks to provide a greater source of credit for homebuilders.

Homebuilders were advised to await improved transportation, labor and financial situations in an address by Mr. Franklin T. Miller, assistant to the Senate committee on reconstruction.

"Wait until transportation is ample, until you can get a full day's work for a full day's pay and until your banker will loan you at least 60 per cent of the value of the building at 6 per cent without bonus," Mr. Miller advised.

THE Architect and Engineer

INCORPORATED

Founded 1905 by E. M. C. WHITNEY

W. J. L. KIERULFF - *President and Manager*
 FRED'K W. JONES - *Vice-Pres. and Editor*
 L. B. PENHORWOOD - *Secretary*
 T. C. KIERULFF - *Attorney*

ASSOCIATE EDITORS

IRVING F. MORROW - *Architectural Critic*
 CHAS. H. CHENEY - *City Planning and Book Reviews*
 WILBUR DAVID COOK, *Landscape Architecture*
 WM. B. GESTER, *Inspection and Tests*
 O. P. SHELLEY, C. E. } *Fireproof Construction*
 F. W. FITZPATRICK, }
 T. RONNEBERG, C. E., - *Structural Steel*
 W. H. LOWE - *Roofs and Roofing*
 FRED'K N. WOODS, JR., - *Rock and Gravel*
 W. H. GEORGE - *Cement*
 CHAS. FELIX BUTTE - *Electrical Construction*
 H. J. BRUNNIER - *Reinforced Concrete*
 I. W. FRICKE, - *School Equipment*
 C. H. WHITE, - *Hardwood*
 WILL J. FRENCH, *Department of Safety*

Published Monthly in the Interest of the
 Architects, Structural Engineers, Contractors
 and the Allied Trades of the Pacific
 Coast by The Architect and Engineer, Inc.

PUBLICATION OFFICE:

627-629 Foxcroft Building, San Francisco
 Telephone Douglas 1828

Portland office: 210 Stock Exchange
 Building, Portland, Oregon.

The publishers disclaim any responsibility for statements
 made in the advertisements of this magazine

TERMS OF SUBSCRIPTION

(Including postage) to all parts of the United States \$2.50
 per annum; to Canada 75c additional; to all Foreign points
 \$1 additional

Vol. LXIV. April, 1921 No. 1

FARM ARCHITECTURE

The "Convenient Farm Home Competition" for the women of Washington to be conducted by the Washington State College, Pullman, in which it is proposed that the women compete in preparing plans for bungalows and two story houses to be judged by a committee of three at the College is a worthy move. Architecture that will make the farm home more attractive is certainly to be desired and it is fit and proper that women should take part in such a competition, says the Builder and Engineer of Seattle. Beautiful farm homes should be more plentiful and will furnish a strong incentive for the boy and girl to remain on the farm. That they do not now remain there is destined to have a serious economic effect upon the country if the situation is not changed.

The Washington State Chapter of the American Institute of Architects has offered its services free to redraw

these plans and design appropriate elevations, these plans then to become available for use in construction of farm homes. Prizes to the value of \$25, each donated by business firms of Washington, will be given for the best two or three plans in each group of farm houses considered. Three groupings are offered.

THE NEED OF A STATE BUILDING CODE

Senate Bill 303, introduced by Senator Jones, provides for the preparation of a State Building Construction Code by the California Industrial Accident Commission, in co-operation with other interested agencies, for presentation to the next session of the legislature.

The purpose of the bill is to give the Industrial Accident Commission jurisdiction to draft an adequate building code which will relieve the dangerous and inadequate requirements now existing throughout the different parts of the State. It is proposed to draft this code in a similar manner to all the safety orders issued by the Industrial Accident Commission and its enforcement will affect many towns in California which are without building inspection departments.

In line with the policy of the Commission it is intended not to interfere with those cities which have adequate building inspection departments, but to co-operate with them for the safe construction of buildings, and to strengthen building ordinances in towns where such regulations are inadequate. Attempts will be made to draft a code with broad general requirements for fire protection, sanitation and structural safety; to cover only the essential features of construction such as will safeguard life and property.

Such safeguarding should not be a burden to the public, but on the contrary should prove a sound business investment. State building codes and regulations have been adopted in New York, Pennsylvania, Ohio and Wisconsin, and California should follow their example.

"BUSINESS MORALS"

A writer who has the reputation of being conservative in his statements, said recently in a nationally circulated periodical that "since the war business morals in the United States have been shot to pieces."

Of course there is not a distinct set of morals for business. Business morals are not different from other morals. Morality in business is the same as morality in anything else. Right is right, and wrong is wrong, in business or out of it. But there are certain morals that business must observe rigidly in order that it may be considered good and clean business, and these are referred to somewhat loosely as "business morals."

It may be said that continued success in business—and by success we do not mean financial gains alone, but the building of business character and prestige and confidence and stability—depends upon strict adherence to certain moral principles and practices, not one of which may be violated or neglected without injury to business reputation.

The first of these is integrity, and it really includes all the rest. The continually successful business man must be scrupulously honest. Double-dealing, evasion of obligations, sharp practice, broken agreements, unkept promises, these are things he avoids as he would avoid outright thievery or the bearing of false witness against his neighbor. His code of business honor does not permit him to do anything but keep his pledged word, whether it mean financial gain or loss to himself.

The word of the honest business man is as good as his bond. His entire business reputation rests upon the strictest observance of every obligation into which he has entered. He would no more think of violating an agreement or of canceling an order, fairly given and fairly received, than he would of robbing a bank or of perjuring himself.

Business morals, says a writer in *The Valve World*, simply means the unvarying application of time-honored honesty and fairness to all

one's dealings with one's fellow men. It means the placing of character and good repute above profits. The genuinely honest business man never will allow himself to depart from this code. Those who do depart from it, even in the slightest degree, will find their punishment, when the conditions which tempted them to transgress have changed, in a besmirched reputation that keeps them without the pale of honest business, withholds from them the confidence of honest associates, and leaves them the uncertain pickings of the desert instead of the fruits of the promised land.

Notes and Comments

When the United States entered the World War, a big heavy-set man New Navy Secretary walked up to a Was Buck Private recruiting desk in Marines the streets of Detroit and held up his right hand.

"Swear me in as a marine!" he said.

"How old are you?" asked the recruiting sergeant.

"Forty-seven," was the answer.

"You are too old," said the sergeant. "What do you want to enlist for?"

The man smiled.

"The country needs men," he said. "All cannot begin as officers. I am ready to be a private."

This man was Edwin Denby, attorney-at-law, president of the Detroit Board of Commerce, and American, then unknown to millions of his fellow Americans. Today he is the Honorable Edwin Denby, bearer of the Republican portfolio as Secretary of the United States Navy and rated "a full man's man" by his former associates of the marine corps.

It took special arrangements at Washington to get Denby into the marine corps. It took waivers of his age, his weight which registered 254 pounds, his height of 72½ inches, and his married status. But he made it through the guidance of Brigadier-

General George Barnett, now in command of the Western Department of the Marine Corps with headquarters in San Francisco. From then on Denby became a marine, heart and soul.

Mixing concrete, unloading lumber, and carrying oyster shells were some of his daily acts of routine. At Paris Island, S. C., he became a lecturer on corps morale, but never for a moment overlooked the fact that he was "one of the bunch."

"Denby could hit a bull's eye at 1200 yards and mix with any buck in the regiment," says Ben J. Cope, newspaperman, who served with him during the World War. Denby went to France in July of 1918 where he was stationed as an observer on the Western front. He returned covered with high honors to become a marine corps reserve major.

"He could outwork any two men and do more smiling about it than six others," Cope declares, summing up the new Secretary of the Navy as a big man who will always remain a "buddy" and a "regular fellow."

Three bills prohibiting the advertising of Trust Service in any newspaper by banks and trust companies have been introduced at the present session of the California State Legislature.

Two are very drastic. The other—Senate Bill No. 21—seems very innocent, yet if this bill became a law, a Trust Company would be prevented from advertising that its own attorney would draw a will for a client.

There would seem to be no public demand for any such measure. All three were introduced in the interest of a certain group of attorneys—and have not the support of the leading attorneys of the State.

Such a law was actually passed in the State of Washington—and the newspapers were automatically cut off from an annual advertising revenue of more than \$75,000.

Building Materials Drop 25 Per Cent in San Francisco

The cost of building materials has dropped 25 per cent in San Francisco and the Bay Region according to a report recently prepared by the San Francisco Chamber of Commerce. Fifteen materials used in building show declines ranging from 5 per cent to 40 per cent, the average being 25 per cent. Prices now compare well with pre-war quotations, and owing to the shortage of stocks, will not go lower, it was announced. Advantage should be taken of the cut in prices to relieve the house shortage situation, it was pointed out. Lumber, which in 1920 sold at from \$40 to \$45 a thousand feet, is now priced at \$30 to \$32. Structural steel has dropped from \$175 to 140 a ton. Nails and hardware show declines of 20 per cent. There has been a drop of 9 per cent in paint, 15 per cent in white lead, 50 per cent in oil, 6 per cent in turpentine, 35 per cent in glass. Pressed brick has fallen from \$60 to \$55 per thousand. Hollow tile has dropped 10 per cent, and electrical material is nearly 20 per cent lower. Hardwood lumber has dropped 40 per cent and millwork is being turned out 10 per cent lower.

If You Have The Money

Build that needed house now. Paint that dwelling, that church, that school. Repair that fence and make the farm look more tidy. Build that highway. It is badly needed. Pave that street. It will help your town. Improve the water-works and extend the sewerage system, for they will better the health of your town. Build that church, that school, that courthouse, and go ahead with everything that shows you are a red-blooded American, with faith in your country. Now is the time for men—real men—to lead off and do things. Cowards only are slackers. The patriot can do as much in this time of peace for his country as he could do in war. Let's play ball!—Manufacturers Record, Baltimore.

Build Bungalow in Ten Hours

An example of the rapidity with which the housing shortage may be overcome was given recently by the Lumbermen's Association of Chicago when thirty workmen employed by the association erected a five-room bungalow within ten hours. The men started work on the foundation at 7 a. m. and completed the house at 5 p. m. The task included installation of electrical and plumbing fixtures and decoration of the interior of the house.

\$20,000 Tacoma Residence

Messrs. Sutton & Whitney, Portland and Tacoma architects, report that a contract for a \$20,000 residence to be built at Tacoma for Mr. F. J. Kenworthy has been awarded.

With the Architects

Building Reports and Personal Mention of Interest to the Profession

Passing of Mr. C. W. Buchanan

Mr. Charles W. Buchanan, senior member of the firm of Buchanan & Brockway, architects, of Pasadena, died at his home, 67 N. Hudson ave., Pasadena, February 3, following one week's illness of pneumonia.

Mr. Buchanan was born in Indiana 69 years ago, was educated in the public schools of that state, learned the trades of carpenter and millwright, and followed the mill supply business for six years. He came to Pasadena in 1885 and engaged in contracting and building. In the meantime he had studied architecture and later took up the practice of this profession. He designed and erected many business structures in and about Pasadena. Five years ago the architectural firm of Buchanan & Brockway was formed, the junior member being Mr. Leon C. Brockway, who had been associated with Mr. Buchanan for a number of years, and who will continue the business.

Visiting Architects Entertained

The annual meeting of the California State Board of Architecture was held in San Francisco April 12 to 14. The Los Angeles members took advantage of their stay in San Francisco and attended a banquet by the local chapter of architects in honor of Mr. S. R. Coolidge, a distinguished Boston architect, who gave an illustrated talk to the members. Mr. Coolidge made the original plans for the Stanford university buildings some years ago.

Seattle School Program

Before the end of the year the Seattle school board will embark on a building program which will mean the expenditure of approximately \$3,500,000. A large part of this work will be started as soon as possible; in fact a call for bids for one school, to cost \$1,200,000, has already been issued. The plans for all the buildings will be made under the supervision of School Architect F. A. Naramore.

To Rebuild Burned Hotel

Mr. Albert Pyle, Call building, San Francisco, has prepared plans for a two-story frame hotel building for the Feather River Inn at Mohawk, Plumas County, to replace the one recently destroyed by fire. It will contain about fifty sleeping rooms and will cost \$150,000. The Van Noy Interstate Company is the owner.

Personal

Mr. B. F. HIRSCHFELD is now associated with Mr. P. Righetti, architect, 12 Geary street, San Francisco.

MESSRS. EDWARD CRAY TAYLOR and ELLIS WING TAYLOR have moved their offices from the Merritt building to larger quarters at 713 West Eighth street, Los Angeles.

Mr. FRANK D. HUDSON has re-entered into partnership with Mr. W. A. O. Munsell for the practice of architecture, with offices in rooms 443-444-445 Douglas building, Los Angeles.

Mr. WILLIAM H. WEEKS, architect of San Francisco, has been invited to deliver a series of lectures on School Architecture at the summer session of the University of California, Department of Architecture.

Mr. JAN FR. KOTTLAND, C. E., has been appointed technical attache of the Czechoslovak Consulate, which has been established at 244 Kearny street, San Francisco. The Consulate wishes to familiarize itself with the important engineering projects, methods of construction, etc., in the Coast states.

Mr. WARREN C. PERRY, architect, with offices in the Newhall building, San Francisco, and instructor in the Department of Architecture, University of California, will leave early in May for a six months stay abroad. Mr. Perry will divide the time in study and travel. Mrs. Perry will accompany him.

Mr. ELMER GREY, architect of Los Angeles, has gone to New York to look over a site preparatory to planning and designing a model village at a station 75 miles north of New York City for a California client. The buildings will all be designed in Colonial architecture, the principal structures being an inn, a steepled church, a general store, a post office and a town hall.

Certificates Granted New Architects

The California State Board of Architecture (Southern District) has granted certificates to practice architecture to the following persons: Messrs. David E. Tostle, 545 S. Euclid Ave., Pasadena; F. B. Rutherford, 1316 11th St., Santa Monica; A. C. Zimmerman, care Reginald Johnson, Pasadena; George E. Gable, care Messrs. Allison & Allison, Hibernian Bldg.; R. E. Coate, care Reginald Johnson, Pasadena, and A. K. Ruoff, 1104 Story Building, Los Angeles.

Will Exhibit Work at Convention

Southern California Chapter, American Institute of Architects will have an exhibit at the Institute convention to be held in Washington, D. C., next month. An architectural exhibit as a feature of the Institute conventions was inaugurated last year. Southern California Chapter did not participate at that time. President Kendall on his recent visit to Los Angeles urged that the Chapter be represented in the exhibit this year and suggested that in addition to work of the members, pictures of the California missions be shown. It was decided to place the entire matter, including the selection of pictures for the exhibit, in the hands of the Education and Publicity Committee composed of Messrs. D. C. Allison, chairman; Myron Hunt, secretary; Reginald Johnson, Carleton M. Winslow and W. J. Dodd.

Hear Talk on Ceramics

At the regular monthly meeting of the Washington State Chapter, American Institute of Architects, held on March 4th at Seattle, Professor Hewitt Wilson of the Ceramics Department of the University of Washington discussed the subject of Ceramics. He went into the matter rather thoroughly, telling to what extensive uses ceramic products are put; how they are made; what is being done in the state toward development of the industry and what resources the state has in the way of raw materials. He devoted some time to explaining the course provided at the University of Washington for the study of the subject.

University Club Building

Messrs. Allison & Allison, 1405 Hibernian Building, Los Angeles, have completed plans for the erection of an eight-story class A club building on Hope street, between Sixth and Seventh streets, Los Angeles, for the University Club. The building will be 65x165 ft. and is estimated to cost \$400,000. The foundation has already been constructed.

Class A Office Building

The Fifth Street Building Co. has been incorporated with a capital stock of \$1,500,000 for the purpose of erecting a twelve-story class A store and office building at the northeast corner of Fifth street and Broadway, Los Angeles. Mr. Albert C. Martin, 430 Higgins Building, is the architect.

Long Beach City Hall

Messrs. Edwards, Wildey & Dixon, 515 Black Building, Los Angeles, have signed a contract at \$337,325, for the erection of a new city hall building, from plans by Mr. W. Horace Austin of Long Beach.

A Deserted City

That the city of Clyde, consisting of 150 homes and one first-class, two-story hotel, situated eight miles from Martinez, may be taken over by the Government as a hospital was the semi-official report from Washington, D. C. Known as the "Rainbow City," because each of the 150 bungalows is of a different color, Clyde is now almost deserted because the Pacific Coast Shipbuilding Company, owner of the city, has practically closed down its plant. More than fifty acres make up the small municipality which was designed and constructed by Messrs. G. Adrian Applegarth, Bernard Maybeck, and E. W. Cannon, San Francisco architects.

Any plan to convert the picturesque cottages and big hotel at Clyde, Contra Costa County, into a hospital for disabled soldiers and sailors is impracticable, according to a statement by Mr. G. A. Applegarth, who is quoted as saying:

"The use of the Clyde properties—the cottages and hotel—by the government for hospital purposes is not a practical proposition, unless they might be used solely for convalescents.

"Hospitals must be constructed for this specific purpose, and there was no such intent in the construction of Clyde. The cottages were planned for workmen's occupancy, and the clubhouse and hotel for their leisure hours.

"But what can be done with the property now that the last ship has been built?

"The houses can be moved off to Bay Point, Concord or Martinez and salvaged. But the hotel and clubhouse will probably have to be 'written off.' No hotel there could survive with the shipping activities removed. So it looks as if the government must pocket the loss."

Architects for Oregon State Work

In Oregon the State Board of Control has appointed the following architects to design state buildings:

Mr. F. A. Legg, Salem, \$50,000, girls' dormitory for feeble minded.

Messrs. Claussen & Claussen, Portland, \$50,000, State Industrial School for girls.

Mr. Chas. B. Martin, Portland, \$15,000, industrial building for the deaf at Portland.

Mr. Jay H. Kellar, consulting engineer, Portland, \$25,000 heating plant for soldiers' home, Roseburg.

Mr. W. C. Knighton, \$280,000 state training school for boys and the \$160,000 wing to the Eastern Oregon State Hospital.

\$30,000 Church

Plans have been prepared by Mr. E. E. McClaran, Lumber Exchange building, for a new Congregational church to be erected at Hillsboro, Ore., at a cost estimated at \$30,000.

Two School Buildings

Mr. Lee A. Thomas, architect, of Bend, Or., reports that plans are progressing for two proposed school buildings, the total cost of which will be \$110,000.

Wit in Chapter Meeting

Washington State Chapter, A. I. A., enjoys the distinction of holding many enjoyable meetings—meetings full of business and yet entertaining. There are some witty members in this chapter as evidenced from the following paragraph taken from the secretary's official minutes of the March 4th meeting:

President Alden asked that the members of the Chapter join the National Fire Prevention Association. Mr. Baeder suggested that the Draftsmen might find it advantageous to join, to prevent being fired.

Roof Tiles in Court

Roof tiles made for a California mission in 1776 were exhibits offered in a patent infringement suit tried before Judge Bledsoe in the U. S. district court in Los Angeles. The tiles are more than two feet in length with a semi-circular section and ornamented with crude designs. They were offered to show that any priority for the use of tiles of that shape could be claimed only by the builders of the early California missions when this state was Spanish territory.

City Planner for Richmond

Mr. Carol Aronovici, consultant to the Berkeley City Planning Commission, has just been employed in a similar capacity by the city of Richmond. He has been commissioned to make a complete planning survey of that city and submit a detailed city plan within the next ten months. He will receive a total salary of \$3,650 for his work.

"Build Now," Slogan at Boise

"Build now" is the slogan adopted by the Boise, Idaho, Chamber of Commerce building committee, which has compiled data to show that the cost of building is at least 25 per cent less than it was a year ago.

Boise architects and contractors back up this claim and some even go so far as to say that building costs have been practically split in two, since a year ago.

Hood River Theater

Mr. H. Ryan, Seattle architect, has plans under way for the erection of a modern theater to be built at Hood River, Oregon, for Messrs. M. E. McCarty and Geo. W. Thomson, and which will be leased to Messrs. A. S. Kolstad and J. H. Ferguson, proprietors of the Liberty theater.

\$200,000 Tulare Hotel

Negotiations have been completed between Los Angeles and Tulare business men for erection of a 100-room hotel at Tulare, to cost \$200,000, according to Mr. J. T. V. Crowe, president of the Tulare Board of Trade.

San Jose Architect Busy

Mr. Chas. S. McKenzie, architect of San Jose, has completed plans for additions to the Live Oak Union High School building at Morgan Hill, and for a frame gymnasium for the same school. Mr. McKenzie has also made plans for an addition, consisting of two classrooms and an auditorium to St. Leo's Parochial School, San Jose, and for a one-story reinforced concrete factory for the Modern Auto Painting Company of San Jose. The same architect has completed plans for a \$15,000 residence for Mr. S. H. Chase, Jr., of San Jose.

Concrete Warehouse

The L. A. Norris Company will build a one and two-story reinforced concrete warehouse, 86x275, on Townsend street, between Second and Third streets, San Francisco, from plans by Mr. H. C. Baumann. The Clinton Construction Company will erect the building. Mr. Baumann also has made plans for a frame flat building to be erected on Thirteenth avenue, four residences on Eighteenth avenue for E. A. Janssen, and a number of cottages in the Richmond District.

San Francisco Studio Building

Mr. Warren C. Perry, Newhall building, San Francisco, has completed plans for a three-story reinforced concrete and frame store and studio apartment building, 40x120, to be erected on Sutter street, below Van Ness avenue, San Francisco, for Mr. H. H. Brown. The cost is estimated at \$40,000. Mr. Perry has also made plans for an \$8,000 house to be built in Berkeley for Prof. E. B. Babcock, University of California.

Architect Has New Venture

Mr. C. H. Jensen, who has been head draftsman in the office of John Reid, Jr., for a number of years, has become a manufacturer's agent and will represent the Vonnegut Hardware Company in the Northern California district, together with several other lines, announcement of which will be made later. Mr. Jensen has opened offices on the mezzanine floor of the Pacific building, San Francisco.

\$20,000 Residence

Mr. Lewis P. Hobart, architect in the Crocker building, San Francisco, has completed plans for a nine-room frame and plaster residence to be built on Jackson street, near Laurel, San Francisco, for Mr. Ernest L. McCormick. The house will cost \$20,000. The same architect has let a contract for a \$30,000 country house at Pebble Beach for Mr. John S. Cravens of Los Angeles.

Architect Weeks Busy

Mr. William H. Weeks, San Francisco architect, reports that he has recently been appointed architect of the proposed new school buildings at Santa Rosa, for which a \$300,000 election has been authorized; he has also been appointed architect of a group of three high school buildings for the Lemoore Union High School District, estimated to cost \$270,000, and for the first unit of a high school group at Lompoc, Santa Barbara County, to cost \$250,000.

Alterations to Elks' Club

Messrs. Wyckoff & White, architects of Salinas, have completed plans for extensive alterations and additions to the Elks' Club building at Salinas. The same firm is preparing plans for a \$12,000 residence for Dr. H. C. Murphy and an \$8000 residence for Mr. Fred Wybert, editor of the Salinas Index.

Apartment House

Messrs. Miller & Warnecke, architects in the Perry building, Oakland, are preparing plans for a two-story frame apartment house to be built at San Luis Obispo, for Mr. Chas. Faxen. It will cost \$45,000. This firm of architects have opened a branch office at Paso Robles, where they have under construction about \$100,000 worth of new work, including a \$40,000 addition to the Hotel Taylor.

Oakland Residence Work

Messrs. Reed & Corlett, architects of Oakland, have completed plans for alterations amounting to \$15,000 to the Piedmont residence of Mr. B. O. Lanerman, and for a \$10,000 house for Mr. A. K. Goodmuidson.

Martinez Apartment House

Mr. August G. Headman is preparing plans for an \$80,000, 74-room, apartment house, to be built in Martinez, Contra Costa County. Mr. Headman has let contracts amounting to about \$26,000 for an apartment house on Geary street, San Francisco, for Mr. Chas. A. Monroe.

Oakland Apartment House

Mr. A. A. Cantin, Foxcroft building, San Francisco, has completed plans for a two-story frame and brick veneer apartment house having nine two-room apartments and three four-room apartments, and to be built at Cottage and Ohio sts., Oakland, for Mr. Hilson. The estimated cost is \$50,000.

Washington Chapter Competition

Washington State Chapter, A. I. A., has authorized a competition among its members for a design for a memorial building at Friday Harbor.

Architect Stewart Busy

Mr. Joseph L. Stewart, architect in the Claus Spreckels building, San Francisco, has completed plans and construction has been started by Monson Bros., for a four-story reinforced concrete commercial garage on Fourth street, near Mission, San Francisco, for Mr. McDougall. The structure will cost close to \$200,000.

Mr. Stewart is preparing working plans for an \$85,000 five-story Class C apartment house for Dr. J. A. Simpson. It will be erected at Leavenworth and Washington streets, San Francisco, and will contain ten high class residence apartments.

College of the Pacific Dormitory

Mr. Wilson J. Wythe, Central Bank building, Oakland, has completed plans for a three-story reinforced concrete and brick veneer girls' dormitory for the College of the Pacific, College Park, near San Jose. The estimated cost is \$15,000.

Sacramento Chamber of Commerce

Mr. E. C. Hemmings, architect of Sacramento, has completed plans for the Chamber of Commerce building to be built in that city. It will be of steel and brick and will cost \$80,000.

Sacramento High School

Plans have been completed by Mr. Edgar A. Mathews, architect of San Francisco, for Sacramento's new high school building, for which \$600,000 bonds have been voted. Bids for the construction of the building will be received till May 4th.

Contract for Berkeley Residence

Mr. W. H. Ratcliff, Jr., architect of Berkeley, has awarded a contract for the general construction of a two-story frame and stucco residence and garage on Sea View avenue, Piedmont, for Mr. Archibald Andrews for \$35,000.

San Francisco Residence

Plans have been prepared by Mr. Earl J. Osborne, architect in the Balboa building, San Francisco, for a \$12,000 house to be erected on Gough street, south of Sacramento, for Mr. J. M. O'Brien.

Oakland Factory

The Durant Motors Company of California has been incorporated and will build a factory on the Foothill boulevard, Oakland, for the manufacture of motor boats, aeroplanes and hydroplanes.

Pebble Beach Residence

Mr. George E. McCrea, Capitola, is preparing plans for a \$16,000 house at Pebble Beach for Mr. Albert J. Houston, a San Francisco capitalist.

With the Engineers

Reports from the Various Pacific Coast Societies,
Personal Mention, Etc.

A Big Road Year and What Engineers Can Do to Make it Bigger

There is excellent prospect that 1921 will be the greatest road construction year in our history. Not only are new appropriations for highways unusually large, but unexpended old appropriations are abnormally great. A very large part of the work that was to have been done in 1920 was held up because of inability to get freight cars. Moreover, labor was scarce and inefficient. Now, however, the railways are able to supply all the cars needed, and laborers are back to their pre-war efficiency.

If any state or county is hesitating about adopting a liberal program of highway improvement, we suggest that the local civil engineering society or club appoint a committee to persuade the public that it is unwise to defer road work. Up to the present, engineers have rarely made organized effort to secure public improvements. They have confined their effort to designing and supervising public works after some one else had secured the appropriations for it. But the time has come when engineers should be leaders of public opinion in all matters relating to public works, and that means that they should become promoters of worthy projects for public improvements. To this end they should address chambers of commerce, city councils, county commissioners and state legislators whenever questions arise as to the advisability of undertaking any important public improvement. They should also write articles for local papers, and arrange to be interviewed by newspaper reporters. Few engineers seem to realize that newspaper editors are always anxious to secure expressions of opinion about public matters from men competent to pass judgment and that they gladly welcome a telephone message asking that a reporter be sent to secure an important interview. Letters to the editor are effective, but not half so apt to attract attention as an interview. A person who is interviewed is regarded as a person of importance, whereas the writer of a letter may be quite unknown and merely interestingly garrulous.

The fine art of getting interviewed is known to most lawyers and business men, but is quite unknown to the average engineer. Yet it is an art easily mastered and well worth mastering.—Engineering and Contracting.

Los Angeles Section, American Society of Civil Engineers

The members of Southern California Section, American Society of Civil Engineers, held an enjoyable ladies' night at the regular meeting, January 12, at the University Club, Los Angeles, and all were agreed that it was a pleasing innovation. About seventy-two members and guests were present. An address by Dr. Ford A. Carpenter, consulting meteorologist, on "Clouds of California," which was the feature of the evening, was most entertaining. He gave a description of cloud formation, types, cloud structure and occurrences which were illustrated by many beautiful lantern views taken from balloons, dirigibles, airplanes and hydroplanes. His experiences in taking these pictures furnished many interesting stories.

Wisconsin Engineers Favor College of Architecture

At the thirteenth annual meeting of the Engineering Society of Wisconsin held during the last week in February at Madison the convention went on record as favoring the establishment of a college or department of architecture at the state University. No institution in Wisconsin gives instruction in architecture.

Engineer Resigns Position

Mr. A. G. Mott, who was secretary of the San Francisco chapter, American Association of Engineers, for the first two years, has recently resigned as Assistant Engineer of the Southern Pacific Company, with whom he was located nearly twelve years, to accept an appointment as Assistant Engineer with the California Railroad Commission.

Stanford Stadium

Plans have been prepared by Prof. C. B. Wing, head of the department of Structural Engineering, Stanford University, for a \$200,000 stadium to be erected on the athletic field at the university. The stadium will be of the sunken type, horse shoe in shape, and will seat 60,000 persons.

Will Plan Water System

Messrs. Stevens & Koon, consulting engineers, 1201 Spalding building, Portland, have been commissioned to make preliminary surveys and prepare data preparatory to constructing a water system to La Grande, Oregon, at an estimated cost of \$500,000.



Fig. 1—This photograph shows the use of Armco ingot iron corrugated pipes to protect a wharf, recently built at Port Orford, Curry County, Oregon, from the ravages of the teredo.

Foiling the "Woodpeckers of the Sea"

By F. W. HAMILTON

THE failure of piers and bridges from the action of the teredo, the "woodpecker of the sea," has given Pacific Coast engineers a knotty problem. These marine woodborers enter unprotected piles which have been driven in salt water, and completely riddle the wood within a short time. Particularly along the coast of Oregon and California have these tiny animals been very destructive, as noted editorially in this magazine last month.

Once the teredo has attached itself to a pile, it lays millions of eggs which soon hatch and before long the pile is honey-combed with borings. It is only a question of time before the support collapses, and the superstructure is wrecked.

A number of methods of protecting piles have been tried. Protective coatings of various substances have in many cases failed to resist the attacks of the worm or the action of the salt water. The smallest crack in a protective coating will allow the teredo to enter and begin its destructive work.

Piles which have been driven with the bark on have in some cases resisted the teredo for many years, but where the bark has been cracked or peeled, rapid destruction has taken place. Bark is always subject to dry rot when it remains above the water line, and cracks from above the high water mark are likely to extend downward and permit the entrance of the teredo. Hardwood resists the worms longer than the rapid-growth soft wood now commonly sold for piling.

Because of their ability to resist the corrosive action of air and water, Armco ingot iron culverts have been found particularly suitable for pile casings. These corrugated pipes have protected the piers

of the Bay City Fish and Storage Co., Bay City, Ore., for seven years and are still in first-class condition.

The port of Port Orford, in Curry County, Oregon, recently installed the

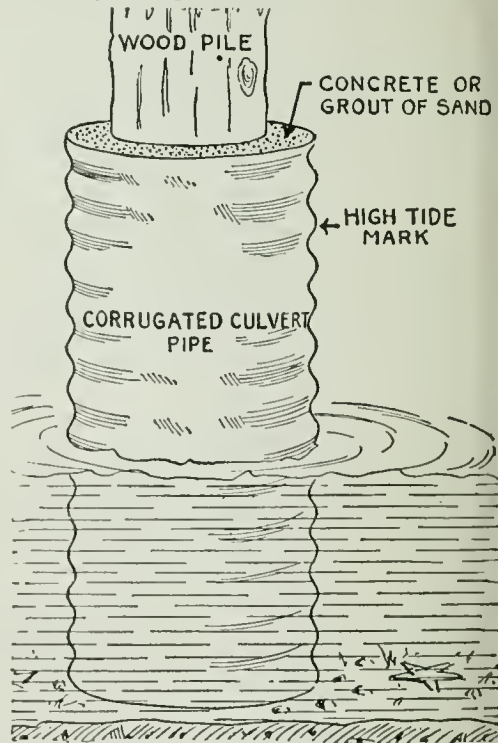

Fig. 2—This drawing shows how corrugated iron pipe may be used to protect pilings from marine woodborers. Note the use of concrete or sand grout to hold the pipe in place.

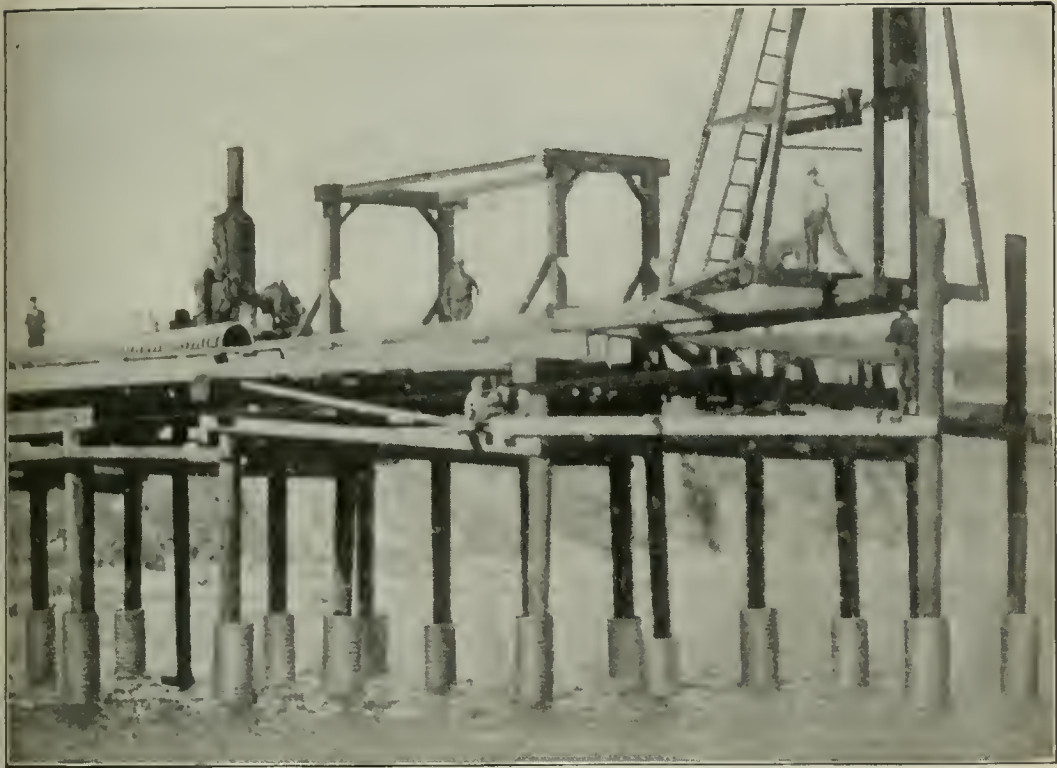

Fig. 3—A close-up view of the wharf recently constructed by the port of Port Orford, Curry County, Oregon, showing how ingot iron corrugated pipes were installed to prevent attacks by marine woodborers.



Fig. 4—Wharf recently erected at Port Orford. The piles are protected from marine borers by corrugated iron pipes.

pier shown in accompanying illustrations and used lengths of Armco corrugated culvert pipe for protecting all piles. In all, 2,000 feet of pipe, 24 inches in diameter, were used for covering the piles.

Figure 3 shows a close-up of several of the piles with their casings of ingot iron.

San Pablo Bay, and Suisun Bay, which are inland arms of San Francisco Bay, have been the scenes recently of attacks by marine woodborers. The unprecedented drouth of the last three years has brought no fresh-water floods from tributary rivers, which would have destroyed the teredos.

Wharves as far inland as the head of Suisun Bay were attacked, and structures at Oleum, Crockett, Port Costa, Martinez, Mare Island and Mallard have been affected.

The wharf of the Sperry Flour Company at South Vallejo, at the entrance of Suisun Bay, has been in service and supported by unprotected piles since 1868. An examination in 1919 showed that teredos had entered the piles, in many cases to a depth of one inch, since salt water entered the bay.

Teredos were blamed for the sudden collapse of the Grangers Wharf at Port Costa which dumped \$10,000 worth of grain into the water—a total loss.

Two wood stave pipe lines, through which the Union Oil Company at Oleum had been pumping salt water, were destroyed by teredos. The borers worked from the inside, having been drawn in through the centrifugal pumps. These pipe lines were operated under a pressure of 40 pounds to the square inch, but in spite of that fact the teredos, when discovered, were in a thriving condition, some of them having attained a length of eight inches.

Official Report on the Marine Borer — Remedies Suggested

THE activity of the marine borers in San Francisco Bay were first noticed almost seven years ago. In 1920 a communication under joint co-operation of the Forest Products Laboratory and Ameri-

can Wood Preservers' Association was appointed to make an investigation. The result of this investigation, presented at the annual convention of the association in January, shows that the teredo navalis borers have invaded San Pablo Bay, Suisun Bay, and up the San Joaquin River 25 miles above Carquinez Straits and 50 miles from the Golden Gate, and up the sloughs of the Delta to Dutton.

This progressive invasion was the direct result of the continued shortage in the annual rainfall and run-off during these years, which permitted the settling of the larval stages on unprotected piling during the breeding season of midsummer and the survival of the borers in the wood during the brief season of the spring freshets of these years. In the upper bay from Pinole through Oleum, Mare Island, Vallejo, Crockett, Port Costa, Benicia, Martinez, to Mococo and Avon, the destruction of piling by this teredo in the summer of 1920 reached a climax which left little or no untreated piling undamaged and not a little of it wholly destroyed by penetration to the center or near it, at the mud-line.

Other marine borers, the xyotrya, limnoria, and sphaeroma, have made inroads nearly as bad.

The following is taken from the committee's report:

There is one outstanding feature of the present outbreak of marine borers in San Francisco Bay and of this survey which affects state and federal supervision of navigable waters and of shipping and engineering practice in the construction and maintenance of marine structures, such as wharves, moles and piers. It is this, namely, that within the area infested by marine borers all unprotected woodwork is a potential breeding ground for harboring these pests, increasing their numbers, and sending forth their migrating larvae. In every case an infected bit of wood is a contagious spot. A single infected pile in 25 feet of water and its 100 square feet of surface affords shelter for upwards of 150,000 teredos, and each of these is capable of producing more than 2,000,000 larvae per year. Each pile, barring the death rate of larvae, thus produces enough young to seed 2,000,000 other piles.

Conclusions Based on the Investigation. Marine borers are very active in San Francisco Bay, and in places where their attack is severe will destroy untreated piling in as short a time as six to eight months. In other places the untreated piling may last two to four years.

HARDWOOD HEADQUARTERS

ASH-BASSWOOD-BIRCH
AROMATIC RED CEDAR
COTTONWOOD-ELM-HOLLY
SOUTHERN RED GUM
HICKORY-LAUREL-MAPE
OREGON MAPLE-PLAIN SAK
QUARTERED OAK
HYBRID BENDING OAK
POPLAR-WALNUT



BOXWOOD-EBONY-IRONBARK
JENISER-KOA-SPANISH CEDAR
LIGNUMVITAE-MAHOGANY
ROSEWOOD-TEAK-BEN BEAN
SPOTTED GUM-CASAHAN WALNUT

LUMBER-TIMBER
HARDWOOD FLOORING
WYBRO VENEERED PANELS
DOWELS-THENAILS-VENEERS

WHITE BROTHERS

FIFTH and BRANNAN STREETS

SAN FRANCISCO, CAL.

Our New Trade Mark!

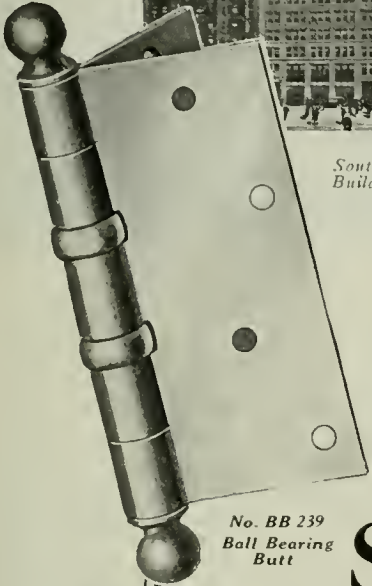

No. BB 239
Ball Bearing
Butt

South
Building

North
Building

THE Garment Realty Buildings, Seventh Avenue, 36th to 38th Streets, New York, — Walter M. Mason, Architect; Garment Center Realty Co., Builder — are equipped with

STANLEY BALL BEARING BUTTS

Architects and builders everywhere have shown their confidence in Stanley products by specifying Stanley Wrought Steel Hardware, whenever permanence and reliability are of prime importance.

Send for New Edition of Ball Bearing Butt Catalog AE-4

THE STANLEY WORKS

Main offices and plant: NEW BRITAIN, CONN.

Branch Offices:

NEW YORK
LOS ANGELES

CHICAGO
SEATTLE

SAN FRANCISCO
ATLANTA



Did you see this advertisement in last month's paper?

The information secured indicates that it is reasonable to expect a life of five to eight years from paint and batten protections if the work is well done. If it is not well done or if the covering is damaged by careless handling this range of life cannot be expected.

When carefully handled so that there is no injury extending through the shell of treated wood within the water section, it appears possible for properly creosoted Douglas fir bearing piling to give a life of 25 to 30 years in San Francisco Bay.

Most of the attack on creosoted piling by marine borers, which the committee has observed throughout this survey, appears to have begun in spots where untreated wood has been exposed by damage in handling the piles or placing the superstructure. It is urgently recommended that improvements be made in the methods of handling creosoted piles and building structures upon them, so that damage to the surface of the piles may be reduced to a minimum.

Precast reinforced concrete piles and pile casings have not been in use in San Francisco Bay a sufficient length of time to determine their ultimate life. A detailed examination of those structures which have been in service for ten years shows no evidence of deterioration and they seem capable of a long further life.

Cast in place concrete pile jackets and cylinders may be expected to give satisfactory results if properly constructed of suitable materials. The difficulties of this type of construction, however, are of such a nature that the probability of securing a maximum length of life is less than in the case of precast concrete piles or pile coverings.

The selection of a type of piling or pile protection for a given structure must be made upon the basis of cost and permanence of the materials under consideration, the character of the structure and the probable need for future alterations to meet the changing requirements of commerce. When a comparatively short increase over the life of green wooden piling is sufficient, the surface protections will often be found economical in waters not exposed to severe storm action; if a moderately long physical life approximating the average economic life of marine structures in this harbor is desired, a good creosote treatment will provide it at the lowest annual cost so far as present knowledge goes; if conditions warrant building for the greatest permanence, with less regard for the first cost, concrete construction may be useful. For the protection from further damage of wooden piles already in place and showing attack by borers, not yet severe enough to require condemnation, the concrete casing, precast or poured in place, is the only means of salvage so far found by the committee.

New Wharf Site

The \$250,000 bonds voted for a new municipal pier at San Diego not being sufficient to meet the cost, and discovery of quicksands on the proposed location for the pier presenting serious difficulties, the San Diego harbor commission has conceived a plan to use the seawall north of the present pier for a wharf. This can be done by dredging in front of the seawall to a depth sufficient to accommodate the largest ships. The seawall is 2500 ft. long and the proposed mole type pier would have provided only 2500 ft. of berthing space. Plans for the new project are being prepared by the city engineer.

Clay N. Burrell Busy

Recent work in the office of Mr. Clay N. Burrell of Oakland includes an \$18,000 apartment house, for Mr. John Brunzell, a \$70,000 garage on Broadway, and a \$30,000 store building on Telegraph avenue, Oakland.

San Gabriel Canyon Dam

Chief Engineer J. W. Regan of the Los Angeles County Flood Control District, explaining the plans for the proposed dam in San Gabriel canyon, stated the project would cost about \$24,000,000. It is proposed to build a dam 425 ft. high, about 300 ft. long at the stream bed and 1700 ft. long at the top, just below the junction of the North Fork with the San Gabriel. The dam would contain 3,000,000 cu. ft. concrete, the cost of which is estimated at \$8 cu. ft., including incidentals and overhead. A reservoir 8 miles long with a maximum width of 1½ miles, comprising 2087 acres and storing 322,000 acre feet of water, would be created. Mr. Regan says the construction of this dam would permanently remove the menace of floods from 102,000 acres of highly cultivated land between Azusa and the ocean. In addition to furnishing water for irrigation, which would yield \$6 per acre ft. or \$600,000 per year, the project would develop 11,450 h. p. electrical energy yielding \$760,000 per year, a total annual revenue of \$1,360,000.

Oregon City Bank Building

Plans for the proposed new building to be built for the Bank of Commerce are now being prepared in the offices of Mr. A. E. Doyle, architect, Worcester building, Portland. A modern concrete structure two and one-half stories high to be 50x105 feet in dimensions is planned. According to present plans, construction will be started on or about May 1.

Another contemplated structure for Oregon City is for Messrs. Frank Busch & Sons, furniture dealers. While plans for a building were prepared several years ago by Tourtellotte & Hummel, Portland and Boise architects, the owners state that the original plan to construct a building has been entirely changed and that a new set of drawings will be necessary.

California State Highway Work.

Contracts have been let by the California highway commission on three additional projects aggregating \$589,340.56, including 23.5 miles of concrete paving and a steel highway bridge over the Feather river near Oroville. This brings the total of contracts let for state highway work during 1921 up to \$1,922,263.16, covering 104.8 miles of road. In no instance have bids for any project been rejected, the accepted proposals generally coming inside the engineer's estimate.

New Engineers' Chapter

At a meeting of about 30 professional engineers of Orange county at Santa Ana it was decided to form a chapter of the American Association of Engineers for that county. Mr. Ben F. Dupuy, city engineer of Fullerton, presided at the meeting. A temporary organization was effected.

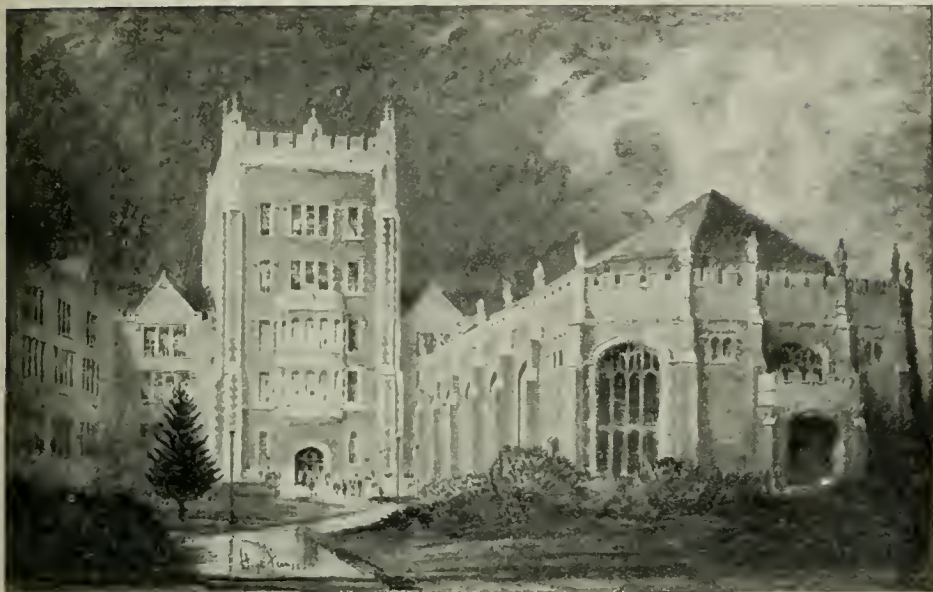

Copyright, 1921, by National Terra Cotta Society

Drawing by Hugh Ferriss

FLUSHING HIGH SCHOOL
NEW YORK CITY

All trim and ornament light grey speckled Terra Cotta

C. B. J. SNYDER, Architect

ARCHITECTURE *and* EDUCATION

*Every Fine Piece of Architecture is a Part of the Liberal
Education of Every Member of the Community*

IN THE design of any building of public character the Architect enjoys a distinct opportunity. He is making a building which will convey the message of architecture to a whole community. And in the case of a school, he is making a building which is to be the cultural environment of young, impressionable minds.

The Architect's responsibility extends in other directions as well as in the direction of creating a beautiful building. He, as a steward of public funds, must design a building which will be beautiful and permanent without unnecessary expenditure.

To secure beauty and permanence with economy, the usual choice is Terra Cotta.

The Architect's essential services to the community and the extensive part played by Terra Cotta in the most important modern building operations are the two themes of the advertisements published each month by National Terra Cotta Society in *The Literary Digest*, in an unusual series which is being read by architects with increasing interest.

NATIONAL TERRA COTTA SOCIETY is a bureau of service and information. Its publications cover not only the technical and structural use of the material but show, as well, examples of its application to buildings of various types.

Brochures of specific value, as indicated by their titles, will be sent to architects on request addressed to National Terra Cotta Society, 1 Madison Avenue, New York, N. Y.

The School The Theatre The Garage The Store The Bank

These brochures consist of a selection of illustrations, with text and comment, showing Terra Cotta buildings of the respective types.

Terra Cotta — Standard Construction

A valuable Reference Technical Work for Architects and Engineers.

Terra Cotta Defined

This new booklet, primarily intended to inform the layman, will nevertheless prove interesting to architects who like to review buildings the country over.

TERRA COTTA

Permanent

Beautiful

Profitable

The Contractor

BUILDING CONSTRUCTION, BRIDGES AND
ROAD WORK

Classification of General Contractors According to Experience and Financial Standing

By E. T. THURSTON.

THE BULLETIN, official publication of the General Contractors' Association of America, has suggested and advocated that contractors be classified according to financial responsibility and business experience as a means of contributing to the welfare alike of the public and the contracting profession. The points of view, respectively, of the head of a large construction company and the editor of a magazine appear to the writer to involve a certain lack of appreciation of the basis of the building business. In this belief the writer is prompted to offer the following remarks:

Every contractor invited to bid on a job has the right to expect an equal chance with every other contractor. This necessarily involves (1) absence of prejudice on the part of the owner and (2) identical terms and conditions for all bidders. It is the private owner's privilege to include or exclude bidders at will, but some general, impartial way of selecting desirable bidders must govern public work. In either case the fact that a contractor is officially invited or permitted to bid should be considered *prima facie* evidence of his desirability as contractor for the work from the standpoint of the owner. This means no less than that the lowest regular bidder is entitled to the

award of the work, provided, of course, he be able to qualify by signing a proper contract and furnishing the necessary bond or other security. Any owner, having received competitive bids, who refuses to award the contract to the lowest bidder competent and willing to qualify as such is guilty of misrepresentation and fraud, unless the aforesaid low bidder is given suitable compensation for his estimate.

Having disposed of these ethical fundamentals, let us consider how bidders may be intelligently selected:

For public work, it is submitted that the only measurable responsibility is financial responsibility, whereas for private work the personal element and the matter of professional and business reputation may properly be considered as even more important than large material resources. In fairness, we see no escape from the universal practice of insuring the responsibility of a bidder on public work by requiring of him a bidder's bond or a certified check. If previous experience with a proposed bidder has resulted in prejudice against him on the part of the public body, the public should have the same authority to refuse him the privilege of bidding as to refuse to award him the contract if his bid is low, and



A LIQUID FLOOR COVERING

For Outside and Inside Floors of Wood, Cement or Concrete

Standard Varnish Works

GENERAL OFFICE:
90 WEST STREET, NEW YORK
San Francisco Offices and Warehouse:
55 STEVENSON STREET

When writing to Advertisers please mention this magazine.

the former procedure would surely be more ethical than the latter.

There are various sources of information available to the private owner for the determination of the responsibility and desirability of any contractor whom he may have under consideration as a bidder; such as his architect or engineer and his banker. Owners and their architects and engineers should be made to realize that they may not invite and receive competitive bids from contractors without obligating themselves to award the work to the contractor submitting the lowest regular bid. By "regular bid" is meant one in strict conformity with the specifications and the call for bids.

The writer sees no merit in the suggestion that contractors be classified according to years of experience and gross annual business. Large personal assets or sheer luck may enable a poor, inefficient contractor to continue in business many years and to carry out successfully, from the owners' standpoint, a large volume of work, whereas limited assets or misfortune may seriously hamper the business of the most efficient contractor. In general, if a contractor pays his bills, no other assumption is warranted than that his business is a financial success. Responsibility is ability and willingness to meet one's obligations. From the layman's standpoint these obligations are in fact exclusively financial. Every contractor knows that years of experience alone will never make a high-grade contractor. Ability, intelligence and integrity are also needed. Every contractor also knows that no amount of ability is absolute assurance against error in estimate and bid. Furthermore, every business man knows that personal endorsements as to moral responsibility and capability are themselves in general irresponsible and as unreliable as they are easy to get. Many years of membership in the American Society of Civil Engineers has convinced the writer that such membership has little influence in securing commissions from laymen; much less influence has one's relative classification therein.

Securing business on a profitable basis is purely a matter of salesmanship, no matter what the line. The keenest, most experienced business man and the most timid, unsophisticated member of society alike capitulate to the clever salesman.

It appears to the writer that contractors give too much attention to the matter of the interests and convenience of the owner, who would be more safely left to his own devices.

Contractors Elect Officers

The Southern California Chapter, Associated General Contractors, has elected the following officers for 1921-22: President, Mr. Godfrey Edwards; Vice-president, Mr. W. W. Brier; Secretary, Mr.

Geo. A. Rogers; Treasurer, Mr. J. F. Hall. Executive Committee: Messrs. Arthur S. Bent, J. F. Atkinson, J. C. Edwards, K. R. Bradley, Brook Hawkins and W. A. Gillette.

Two members were added to the executive committee, Messrs. Hawkins and Gillette being nominated from the floor to fill these positions.

Two members were added to the executive committee, increasing it from eight to ten members, including officers of the Chapter.

Wages Reduced in Building Crafts

The Board of Arbitration for the San Francisco district building industry, concerning the question of wage reduction, has submitted its report, following months of investigation. The report awards a general reduction in the wage of seventeen crafts.

The new schedule became effective April 11, and is to continue six months, at the end of which period wages will again be adjusted to conditions at that time.

Craft—	1914	1921	New Award
Roofers	\$6.00	\$9.00	\$8.35
Marble Polishers	3.50	6.50	6.00
Bed Rubbers	4.00	7.00	6.50
Cement Laborers	4.00	7.50	7.05
Glass Worker	4.50	8.50	7.85
Truck Driver	4.00	7.00	6.50
Team Driver	3.00	6.00	5.55
Varnisher, Polisher (inside)	4.00	7.50	6.95
Varnisher, Polisher (outside)	5.00	8.50	7.85
Marble Cutter	4.50	7.50	6.95
Marble Setter	5.00	8.00	7.40
Marble Helper	3.00	6.00	5.55
Elevator Const.	5.00	8.50	7.85
Elevator Helper	3.00	6.00	5.55
Cement Finisher	6.00	9.00	8.35
Painter	4.50	9.00	8.35
Iron Worker	5.00	8.50	7.85
Hoisting, Port. Eng.	6.00	9.00	8.35

[EDITOR'S NOTE. Since above was written the Board has suspended its ruling indefinitely.]

Letters From Subscribers

The Architect and Engineer, San Francisco.

I am enclosing you Postal Order for \$2.50 in renewal of my subscription for the above magazine.

As you may see Shanghai possesses a United States Post Office which means that domestic rates prevail on all mail matter sent to this port and does not come under the heading of Foreign Postage.

Kindly keep my subscription in force at all times in order that I may keep my files up to date, when same elapses and I will remit to you immediately upon your notification.

It has occurred to me sometimes whether you would be interested in photographs of Chinese Architecture in existence here, or notes on the erection of Foreign buildings with photographs for publication, if so I would be only too pleased to see what could be done in the matter should you so desire to entertain the idea.

Yours very truly,

Shanghai,

G. O. WOOTEN.

The Architect and Engineer, San Francisco.

Enclosed find check for \$2.50, subscription to March, 1922. Do you publish books on California architecture. Interested in homes on Italian lines Americanized.

Yours very truly,

Tulsa, Oklahoma,

LAWRENCE E. BLUE.



BUILDING BUSINESS

CALIFORNIA'S OLDEST NATIONAL BANK
HAS BEEN A VITAL FACTOR IN THE UPBUILDING
OF SAN FRANCISCO AND THE ENTIRE WEST.

WHEN LAYING PLANS FOR THE FUTURE OF YOUR
BUSINESS CONSULT THE OFFICERS OF THIS INSTITUTION

THE FIRST NATIONAL BANK OF SAN FRANCISCO

Affiliated with

FIRST FEDERAL TRUST COMPANY

Combined Resources \$60,473,521.88

Proposed Code of Ethics

Of the Associated General Contractors of
America as Submitted by the Committee of
Ethics at New Orleans

THE following tentative draft of a Code
of Ethics or Practice for general con-
tractors, members of the Associated Gen-
eral Contractors, is submitted for considera-
tion and suggestions:

ARTICLE I

Purpose

The purpose of the Code is to define briefly the
rules of professional conduct and ethics for the
members of The Associated General Contractors
of America.

ARTICLE II

Improper Practice

It shall be considered unprofessional and in-
consistent with honorable and dignified bearing
for any member of The Association General Con-
tractors of America.

1. To act for his clients in professional mat-
ters otherwise than as a faithful agent or trustee,
or to accept any remuneration other than (a) that
stipulated in the contract or (b) his customary
charges for similar professional services to other
clients.

2. To attempt to injure falsely or maliciously,
directly or indirectly, the professional reputation,
prospects, or business of another general con-
tractor.

3. To alter a prepared bid after being informed
of the bid of a competitor.

4. To lend his name to any questionable en-
terprise.

5. To engage in any movement which is obvi-
ously contrary to law or public welfare.

6. To engage in undignified, sensational or mis-
leading advertising.

7. To submit bids on a basis other than that
requested unless a bid on the basis requested is
submitted for comparative or other purposes.

8. To accept a contract at the price submitted
by the lowest but disqualified competitive bidder.

9. To seek information concerning the bid of a
competitor and make use of the knowledge thus
obtained for his own gain or for the competitor's
detriment.

10. To collect money for making an estimate
where plans for securing payment for estimating
are in force, without the knowledge of the owner
or his representative.

ARTICLE III

Skill, Integrity and Responsibility

"Skill, Integrity and Responsibility," our slogan,
requires

1. That in all their relations, our members shall
be guided by the highest principles of honor.

2. That the dignity of the construction industry
be upheld to the public at all times and its mem-
bers protected against misrepresentation.

3. That a personal helpfulness and fraternity be
maintained among our members and toward the
profession generally.

4. That sensationalism, exaggeration and un-
warranted statements be avoided and discouraged.

5. That clients be frankly advised when projects
are undertaken which our members from former
experience have found to be unprofitable.

6. Conservatism in all estimates, reports, testi-
mony, etc., especially in connection with the prom-
otion of business enterprises.

7. That when one of our members undertakes
for a client work in connection with which he may
make improvements, inventions, plans, designs or
other records, he shall preferably enter into a
written agreement regarding their ownership.

8. That a member cannot honorably accept
remuneration financial or otherwise, from more
than one interested party. "No man can serve
two masters."

9. That when a member is called upon to de-
cide on the use of inventions, equipment, methods,
etc., in which he has a financial interest, he should
make his status in the matter clearly understood
before engagement.

10. That credit be given where credit is due.

11. That where bids are requested an effort
should be made to have them opened publicly at
a specified time and place, known to all bidders.

12. That bona fide bids carefully prepared be
submitted whenever solicited or the reasons for the
inability or unwillingness to comply be stated—
frankness in these matters will establish the ob-
viously fair principle that all solicited bids are
entitled to consideration and the bid thus solicited
which is most favorable to the owner should be
accepted.

TRANSMISSION EQUIPMENT

For Mill or Factory

Pulleys - -	Shafting - -	Gears - -
Hangers - -	Bearings - -	Take Ups - -
Sprockets -	Clutches - -	Chain Belts -
Floor Stands	Belt Tighteners	Rope Sheaves

Meesco Short Center Drives

Meesco & Gottfried Company

ENGINEERS AND MANUFACTURERS

CONVEYING, ELEVATING, SCREENING
AND MECHANICAL POWER TRANSMITTING
MACHINERY

SAN FRANCISCO 660 Market Street	SEATTLE 555 First Ave. So.	PORTLAND 67 First Street	LOS ANGELES 660 North E Street
------------------------------------	-------------------------------	-----------------------------	-----------------------------------

DEPENDABILITY

ONE reason why ATLAS-WHITE Portland Cement is so often included in the specifications of prominent architects, is their recognition of the fact that it is a true Portland cement, pure white in color, thus making possible an unlimited variety of unusual concrete surface treatments.

The services of the Atlas Technical Department are always at the disposal of Architects and Engineers.

THE ATLAS PORTLAND CEMENT COMPANY

New York Boston Philadelphia Birmingham
Chicago Dayton Des Moines St. Louis

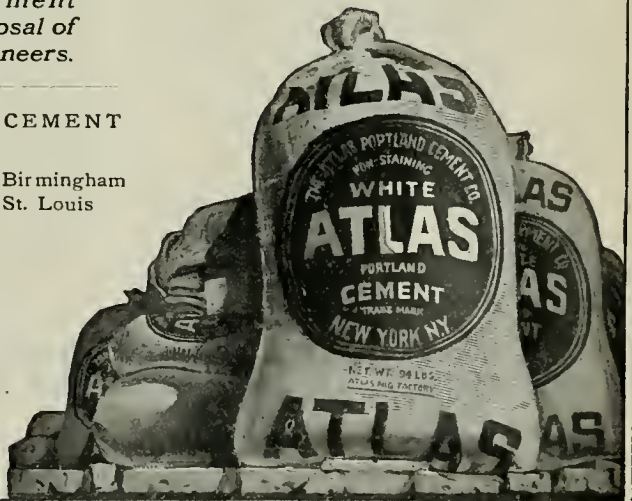

ATLAS WHITE

NATIONAL WINDOW SHADE COMPANY, Inc.



Phone Franklin 552

244 EDDY STREET, SAN FRANCISCO, CAL.

Agents for
BRENLIN

The Long Wearing
Window Shade
Material

National Shades wear
twice as long as the
ordinary kind

13. That constant pressure be exercised to have all bidders notified whenever it is the intention to request bids to the same or part of the same work from both sub-contractors and general contractors.

14. That when a limited number of general contractors are requested to bid the names of those invited to bid should be made known to all those who are so invited.

15. That all general contractors expose without fear or favor before the proper tribunals, corrupt or dishonest conduct in the profession and accept without hesitation employment against a member who has wronged his client.

16. That where injury concerning professional matters is indulged in, the matter be publicly brought to the attention of the prosecuting authorities.

17. That all members guard the Association against the admission to its membership of candidates unfit or unqualified because deficient in either moral character or professional ability.

18. That competitors and their work be treated with fairness whenever clients discuss them with general contractors.

19. That all work be so creditably performed that the Seal of the Association will continue to symbolize the highest professional ideals.

20. That when any member is charged publicly with using questionable methods, he should voluntarily present all facts to the Committee on Ethics.

21. That the honor of every member be defended when wrongfully accused.

22. That all fraudulent misrepresentations be exposed as a duty to the public and the profession.

23. That work shall not be contracted for at less than cost with the hope or intention of finding enough "extras" to take care of the profit.

24. That existing agreements between general contractors and labor, architects, engineers or others be respected whenever work is done in the locality affected by said agreements. Should extenuating circumstances prevent adherence to these agreements the general contractor should confer with the general contractors who are parties to the local agreements, in order to work out the best

substitute or else he should publicly announce his intention to disregard the agreements, and give his reasons for so doing.

25. That general contractors work loyally for the success of measures brought forward to benefit their industry, regardless of their immediate interest or lack of interest in such measures.

26. That the public welfare be promoted at all times and particularly in matters in which the general contractors' experience qualify them to act; giving freely of their counsel and support and holding themselves in readiness to assume responsibilities when called upon, bearing in mind that the public welfare is paramount and that the customary villification practiced by those who have been thwarted in controlling such matters or finding berths for henchmen has no effect upon any unbiased mind.

ARTICLE IV

The Owner or Client

The proper relationship of the general contractor to the owner (or client) requires:

1. That no contract should be undertaken which the contractor is unable economically and efficiently to complete.

2. That the owner be intelligently advised of all things which may promote his interests in the successful prosecution of the project.

3. That advice should not be given to owners on subjects concerning which the general contractor is not qualified to advise.

4. That controversies with owners concerning compensation are to be avoided so far as shall be compatible with self-respect and with his right to receive his contractual or reasonable compensation for his services; and lawsuits with owners should be resorted to only to prevent injustice, imposition or fraud.

5. That members keep constantly in mind that the results of their labor are permanent assets, having a definite economic and taxable value, in contradistinction to consumable or materialistic products, and that laxity in execution may in after years reflect discredit on the profession.

UNITED BLOWER Co.

INC.
UNITED MULTIVANE

HEATING
AND
VENTILATING

Induced and Force Draft
Apparatus, Dry Kilns, etc.

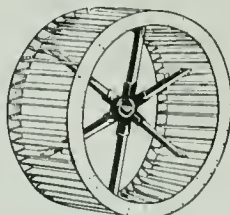

FAN WHEEL

Factory:
1267 Folsom Street
San Francisco

Phone Park 1536
Branch Office, Los Angeles

Who Gets in First?

Two salesmen were one day in the ante-room of F. Smith, General Manager of Armes & Werner, who was in the market for pumps. According to custom, Smith first asked his secretary for the letters that had preceded his callers presenting their cases.

Smith hastily scanned the two brief letters. He did not know either of the salesmen. But their propositions, bids, specifications, and so on struck him as being equally acceptable, equally well presented.

For just a flashing instant he considered the two letters. And it was right there that he perhaps unconsciously estimated the men he had to see—and the firms that they represented—by the appearance of two letters of equal appeal. His attention stopped on the letterhead which introduced the firm of MINER & CROFFITT, tastefully lithographed on a crisp, bond paper and suggesting a firm of stability. The other was barren of any such suggestion—it was on a cheap quality of paper, poorly printed, and the impression it gave was a negative one.

"Miss Collins," he directed, "send in Mr. Wade of Miner & Croffitt"—

and that is how a \$12,000 order and an enviable business connection was obtained by Wade's firm.

Were either of these salesmen to blame? Hardly. It was just another case of the order going the way of the most pleasing introduction. It happens every day—sometimes because of personal address, or again by virtue of well chosen stationery.

H. S. Crocker Company considers the preparation of distinctive and dignified letterheads on good quality paper so important that there is always at your disposal the services of expert designers and pressmen. The more you consider the Mr. Smiths of business life, the more you will appreciate that Crocker stationery is no trifling garnishing but a business asset to command respect for your salesmen and firm.

Remember, you write more often than you call personally.

H. S. CROCKER CO., INC.

565-571 Market Street, San Francisco

Los Angeles

1444 Broadway, Oakland

Sacramento

ARTICLE V
Administration

1. Administration of this Code of Ethics shall be performed by a Committee on Ethics consisting of five members appointed by the President holding office at the time of the adoption of the Code. One Committee member shall be appointed for five years, another for four years, another for three years, another for two years, another for one year, and thereafter, the President then holding office shall appoint one member annually to serve for five years and also fill such vacancies as may occur for an unexpired term. All of these members shall be over forty years of age. The Committee shall select its own Chairman. The Committee on Ethics shall investigate all complaints submitted to it bearing upon the professional conduct of any member, and after a fair opportunity to be heard has been given to the member involved, shall report its findings to the Executive Board, whose action shall be final.

2. Discipline for violation of this Code shall be determined by the Executive Board, after the facts have been reported by the Committee on Ethics.

OR

(The following paragraph is submitted as an alternative.)

2. Upon specific complaint made by or through one member against another, of violation of the Code of Ethics, such complaint shall be referred to the Committee on Ethics, which shall promptly give the complaint full and fair investigation in such manner as it shall deem proper, save that the accused must be given an opportunity to be heard in his own defense. The findings of the Committee on Ethics shall be transmitted to the Executive Board for action. If the accused member is found guilty of the charges preferred, it is the duty of the Executive Board to discipline him, either by censure, suspension for a period not to

exceed one year, fine not to exceed Two Hundred (\$200.00) Dollars, or expulsion; the action of the Executive Board to be final and its action published or otherwise to be brought officially to the notice of all members.

ARTICLE VI
Amendments

Upon thirty (30) days' notice stating the change proposed, this Code of Ethics may be amended by a two-thirds vote of the entire Executive Board or by a majority vote of the Association voting in Convention or by letter ballot.

Tin Pipes As Heat Conveyors

UNCOVERED bright tin pipes are more efficient carriers of heat than asbestos paper-covered bright tin pipes. This surprising discovery was made by the Engineering Experiment station of the University of Illinois.

In May, 1919, it was observed in some tests that the actual heat loss was greater through the asbestos paper-covered pipes of furnaces than through the same pipes uncovered. A complete study of the various insulating materials, coverings and surfaces was felt justified and the following significant results as applied to warm-air furnace heating are deserving of special emphasis.

(1) The use of thin sheets of asbestos paper on bright tin heat pipes results in a waste of heat. The use should be abandoned.

(2) Uncovered bright tin pipes are more efficient carriers of heated air than asbestos paper-covered bright tin pipes.

(3) This fact is true regardless of the degree of brightness of the tin surface.

(4) No small number of applications of asbestos paper will suffice as an insulator. Several thicknesses are necessary to make a covering equal in this respect to the bare tin.

(5) The accumulation of dust and dirt on the pipes does not greatly alter the amount of the loss.

(6) The heat loss from warm-air furnace pipes covered with one layer of asbestos paper is a serious item in the cost of heating, amounting to more than 5 per cent of the coal consumption, depending upon the number and size of the pipes used.

(7) The fact that pipes are partly protected from convection currents of air by joists and studding does not greatly affect the loss.

(8) Unless the insulation excels the uncovered bright tin in heat insulation properties it should not be used.

(9) Such materials are available and the tests have shown their merits.

These facts are covered in a bulletin recently issued by the Engineering Experiment station of the University. The investigation was made in co-operation with the National Warm-Air Heating and Ventilating association.

LA FRANCE SAFETY DEVICES
FOR EVERY INDUSTRY

**Consider Fire Protection
in Making Your Plans**



If you are planning a factory provide a space for a LaFrance No. 20 Chemical Engine, for it is simple in construction and easy to operate. It contains twenty gallons of fluid forty times as effective as water for extinguishing fires. It is made by the world's largest manufacturer of fire apparatus,

with a full knowledge of what is best for effective fire fighting.

Write for complete information in regard to this and our other appliances, such as Hose, Hose Racks, Reels, Nozzles, Axes and many others.

AMERICAN LA FRANCE FIRE ENGINE COMPANY, INC.

ELMIRA, N. Y.

929 South Hill Street,
Los Angeles, Calif.



151 New Montgomery
Street, San Francisco,
Calif.

Which Do You Prefer?

*This Old Style
Tub With Its
Exposed
Metal Parts*

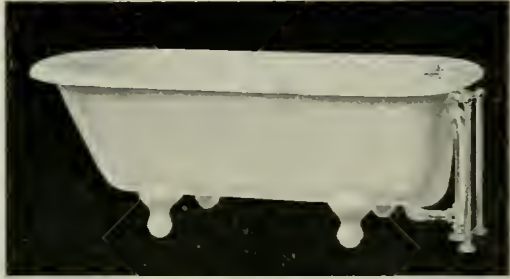

OR

*The New
All-in-One
Tub With
No Exposed
Metal Parts*

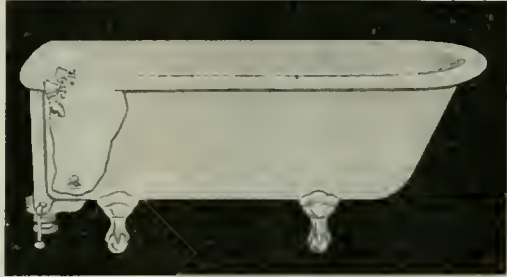

Patent Applied For

Compare the above bathtubs carefully. You are no doubt familiar with the old style tub, with its unsightly, unsatisfactory exposed pipes and metal parts.

Now study the new All-in-One Bathtub. This new tub has eliminated all of the connecting joints of the old style fixture by casting the hot and cold water inlets, waste pipe, overflow integral and bath cocks with the tub itself. No exposed metal work—the entire fixture is finished in white enamel. Patented waste plug with spring and cap that cannot be lost.

The All-in-One is more attractive, more practical and more economical. It is easier to install, there being only one connection made at the bottom of the tub—it is easier to keep clean—and it costs no more than the old style tub.

All-in-One Bathtubs are made in all the various styles. All-in-One Lavatories are designed on the same principle and are also made in all sizes and styles. Write today for catalog fully describing the All-in-One line.

All-in-One Company

Dept. A

Marsh-Strong Building, Los Angeles

Oppose Union-Made Plans

THE General Contractors' Association of Newark, N. J., together with the local architects and engineers, is defying the Building Trades Council's demand that they use only plans made by union draftsmen or engineers, which would make them unionize.

Following a demand of the Building Trades Council of Newark, N. J., made about the middle of October, that all plans for buildings and structures made in Newark must be drawn by members of the Engineers' Architects' and Draftsmen's Union, steps to negative this attempt to force engineers to unionize were inaugurated by the American Association of Engineers and by the New Jersey Chapter of the American Institute of Architects.

The demand of the unions was to the effect that after November 1, 1920, union labor, composing the Building Trades Council of Newark, would do no work on new buildings or other structures for which the plans were not made by union draftsmen or engineers.

In commenting on this situation in a letter published in the Newark Call of October 31, Mr. C. E. Drayer, secretary of the American Association of Engineers, said, "The question of trade unionism in the engineering profession has been carefully considered by the American Association of Engineers and the action taken at the annual convention last May, pronouncing the advocacy of trade union methods by a member as cause for expulsion, would leave no room for doubt."

Draftsmen in the architect offices in Newark have been canvassed on the question of union affiliation and almost to a man they are opposed to any unionization of draftsmen, engineers or architects. The General Contractors' Association of Newark will continue to use plans made by non-union architects and draftsmen. Mr. James O. Betelle, president of the New Jersey Chapter of the American Institute of Architects, is working in harmony with the American Association of Engineers in this matter.

A New Stanley Screen Hardware Book

The new Screen Hardware book has just been published. The measurements of this book are 3½ in. by 6¼ in.; 24 pages and printed in two colors; containing the complete line of Stanley Screen Hardware for doors and windows.

The book is of interest to the consumer of this line of hardware as the articles are illustrated in use upon either door or window. A copy will be sent free to those interested.

When writing to Advertisers please mention this magazine.

To Architects:

It certainly is logical to presume that if a Contractor were furnished a *bill of quantities* on a particular piece of work and that said Contractor was *guaranteed* that the bill of quantities was sufficient to complete the work; that this would eliminate one of the risks of contracting; and obviate the addition of a percentage to his bid to cover this contingency.

This is what the Planing Mill Listing Bureau is doing for the Millwork part of Building Construction.

Guaranteed lists on any construction are supplied at a reasonable charge to interested parties whether Architects, Owners or Contractors.

We invite the co-operation of the Architects that we may be supplied with plans and specifications from which to prepare these lists of quantities; and these in turn will, *at Architect's option*, be priced by the majority of the mills of the city and the attention of the particular plants prepared to handle the work involved, will be drawn thereto by us.

With your co-operation the time lost by Contractors soliciting bids from the various mills will be saved.

This method is not a novelty, it has been tried out in practical use here for a couple of years, and has proven its adaptability to existing conditions and has resulted in an economic gain to its adherents in expense elimination.

Correspondence solicited and investigation of operation and responsibility is courted.

PLANING MILL LISTING BUREAU

Room 234

Builders' Exchange Bldg.,

SAN FRANCISCO

INCREASES PROFITS
FURNITURE SAVING

U-TURN-IT

SAVES MUCH SPACE
SELF VENTILATION

Converts a 1-Room into A 4-Room Apartment

The Device is less than seven feet in diameter, seven feet six inches high, built of steel frame, and revolves on ball bearing floor ring; weighs, installed, 1500 pounds.



Combined View of Library and Kitchen.

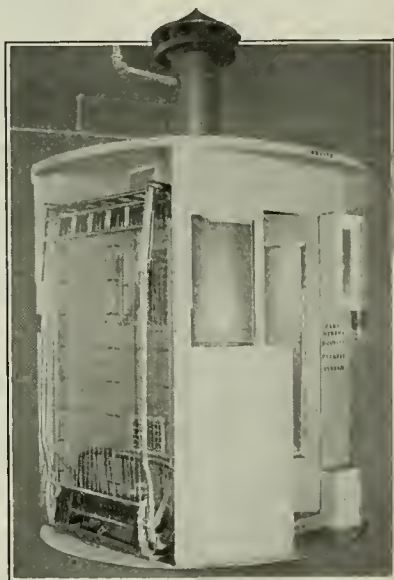

Bed and Dresser with Wardrobe.

Installed in new or old buildings, converts a one room into a four room apartment, containing conveniences of combination dresser, wardrobe and interior clothes closet; bedroom standard recess balanced lift bed, next to self ventilated ducts from the outer air when bed is in or out of use; library with writing desk, book cabinet and storage compartments; kitchen with complete plumbing, sink, hot and cold water, air tight revolving joints, designed to revolve with the U-Turn-It (approved by the Bureau of Plumbing Laws of the City of Buffalo, N. Y.) ice box and drain to sink, ironing board, china and kitchen utensil compartments; electrical, gas or oil hot plate stove, ventilated over head, and also garbage compartment with sanitary lining throughout.

Different types are made with two beds opposite for use in two or more rooms. Also types with kitchen omitted.

AGENTS WANTED IN PRINCIPAL COAST CITIES.

U-Turn-It Housekeeping System, Inc.

1202-1204 Claus Spreckels Building

SAN FRANCISCO, CALIFORNIA

Frank Bryant with United Blower Co., Inc.

San Francisco architects and contractors will remember Mr. Frank Bryant who was formerly in charge of the heating department of the old Henshaw-Bulkley Company in Fremont street, and later with the Machinery & Electrical Company of Los Angeles. Mr. Bryant is now Southern California representative of the United Blower Company, 1267 Folsom street, San Francisco, and of which Mr. J. Ringius is the president and manager. A large order placed by Mr. Bryant in the southern city for United Blower equipment has just been filled, the installation being in the new building of the Pacific Mutual Life Insurance Company. Mr. W. G. Sadler, for many years with the B. F. Sturtevant Company is now with the United Blower Company as factory superintendent.

San Francisco Builders Elect Officers

Mr. Charles W. Gompertz has been chosen president of the San Francisco Builders' Exchange, the other officers elected being Mr. W. H. George, first vice-president, Mr. Joseph B. Keenan, second vice-president, Mr. Charles Cadman, secretary, and Mr. Alex Mennie, treasurer. The other six members of the board of directors are Messrs. J. D. McGilvray, J. A. Hart, L. J. Neal, J. H. Pinkerton, D. J. Sullivan and E. S. Rainey.

Coast Contractors Honored

Mr. W. O. Winston of Minneapolis is the new president of the Associated General Contractors of America. Mr. Arthur Bent of Bent Bros., Los Angeles, is one of the vice-presidents and Mr. Geo. C. Mason of the Hurly-Mason Company, Portland, Oregon, is a director.

Don Pedro Dam Contract

After awarding a contract on a cost-plus a fixed fee basis for constructing the Don Pedro dam the directors of the Modesto and Turlock irrigation districts, yielding to opposition of the land-owners, rescinded their action, and the work will be carried on by day labor.

Santa Fe Lumber Company

The Portland Lumber Company's activities in San Francisco and the Bay Region, are now being conducted under the name of the Santa Fe Lumber Company with offices at 16 California street, in charge of Mr. H. M. Gunton.

Ten Story Apartment House

Mr. Kenneth MacDonald, Jr., architect of San Francisco, is preparing plans for a ten-story reinforced concrete apartment house for Mr. John D. McKee of the Mercantile Trust Company. The building will be built at Laurel and Jackson streets, San Francisco.



From the First Vision To the Finished Building

MANY architects when they conceive the new building of concrete or stucco have Bay State Brick and Cement Coating in mind to help carry their vision to completion.

For Bay State transforms the drab color of cement or stucco to a rich white or one of many beautiful tints. It creeps into every pore and seals the walls against dampness. Driving rains cannot beat through it. Snow, hail, wind or burning sun will not harm it.

Write for samples in white and colors, and Booklet No. 43. Your request on a postal will bring you both.

WADSWORTH, HOWLAND & CO., Inc.
Largest Paint and Varnish Makers in New England
Boston, Mass.

JAMES HAMBLY & SON, Representative
San Francisco, Cal. Los Angeles, Cal.



BAY STATE

Brick and Cement Coating



A FLOORING for discriminating Architects and Builders, and characteristically a Michigan product in every way, from the excellence of the wood itself to the superior millwork and careful grading.

Strable Hardwood Co.

HARDWOOD LUMBER

Phone, Oakland 245

511-545 FIRST STREET OAKLAND, CAL.



The
ST. FRANCIS
One of the world's great hotels
Facing Union Square
SAN FRANCISCO CALIFORNIA

EXPRESSES MOST PLEASANTLY THE HOSPITALITY AND ANIMATION THAT ARE CHARACTERISTIC OF SAN FRANCISCO

Thos. J. Coleman
Manager

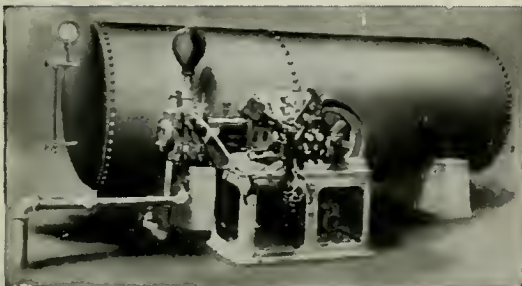

Kewanee Water System

Maintain your own Plant.
Small Operating Expense.
A Perfect Water Supply to
Country Homes, Hotels
and Parks.

Simonds Machinery Co.

117 - 121 Montgomery Street
SAN FRANCISCO
Phone Kearny 1457



"All chimneys, irrespective of which materials the walls are built, shall be lined with fire clay flue lining or with fire brick. The lining shall be made for the purpose and adapted to withstand high temperatures and the resultant gases from burning fuel." From "An Ordinance for Construction of Chimneys" recommended by the National Board of Underwriters, 1920.

Oust a Cruel "FIRE-BUG!"

Statistics show clearly that the most prolific "fire-bug" in residences is the *unlined* chimney. From one-fifth to one-third of the fires that endanger homes originate in chimneys. Fire Clay Flue Lining insures the safety of the families of your clients against the worst single cause of fires. A few dollars per chimney is all it costs. A trifle to include — an important thing to specify.

Write for a copy of the 1920 recommendations of the National Board of Fire Underwriters Committee on Construction of Buildings.

CLAY PRODUCTS ASSOCIATION
PITTSBURGH CHICAGO
Los Angeles Pressed Brick Co., Los Angeles, Member
FIRE CLAY FLUE LINING

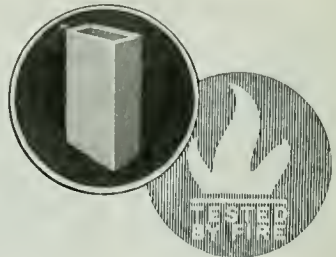

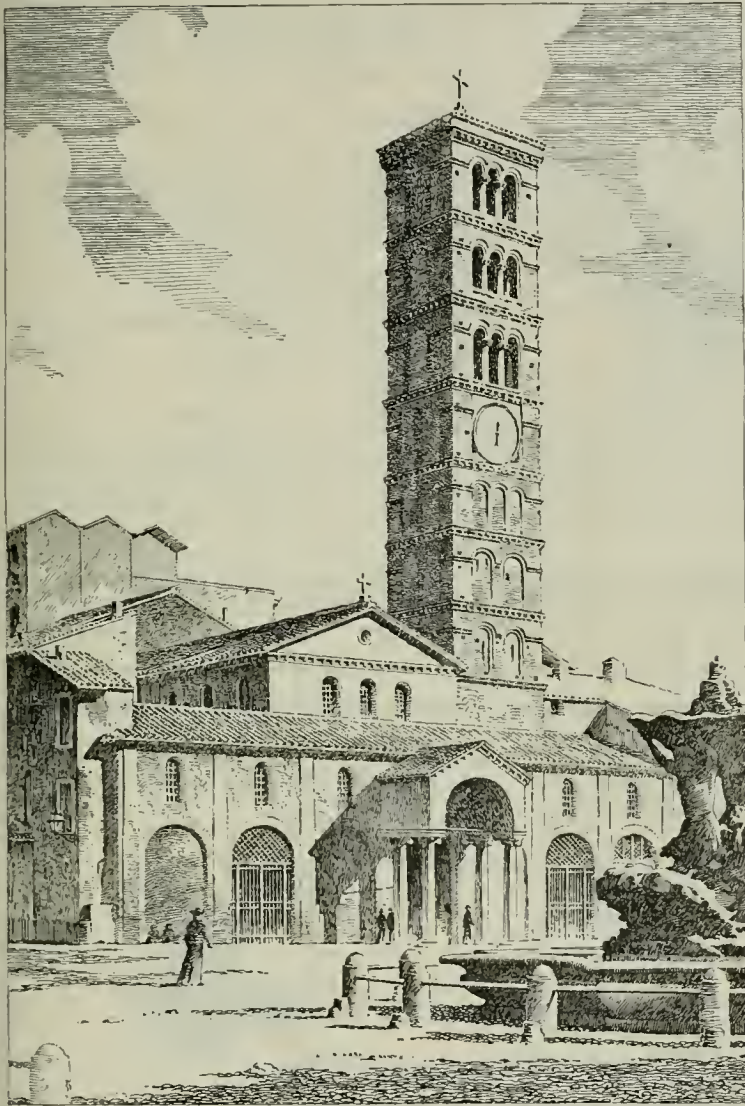

A F B A
USE FACE BRICK
— it Pays

St. Maria, in Cosmedin,
Rome, Italy
Built about 800

WE SHOULD like every architect to have a copy of "The Story of Brick," for it discusses in a comprehensive way the history and merits of face brick. Some of the chapter headings are: Brick in History, Three Basic Requirements in Building, Home Building, Comparative Costs and The Extravagance of Cheapness in Building.

Architects who are building small houses will

also be interested in "The Home of Beauty," which presents the fifty designs selected by the jury of awards as the best submitted in a recent architectural competition which the "Architectural Forum" conducted for the American Face Brick Association.

Either or both of these booklets will be sent without charge to any architect asking for them on his office stationery.

AMERICAN FACE BRICK ASSOCIATION

1159 WESTMINSTER BUILDING · CHICAGO, ILLINOIS

Use SCHROEDER Direct-Flush Valves

The only All Brass Flush Valve for Toilets on the Market

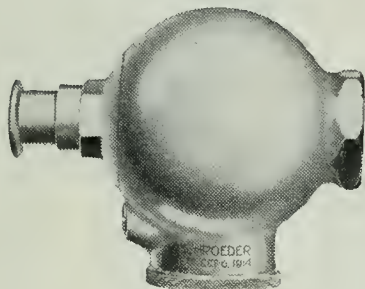

MADE IN FOUR SIZES
 $\frac{1}{2}$ in. $\frac{3}{4}$ in. 1 in. $1\frac{1}{4}$ in.

Unexcelled Simplicity of Construction

Eliminates Repair Bills	No By-Passes
Eliminates Water Waste	No Rubber or Leather Parts
Eliminates Corrosion	No Complicated Parts to get out of order
Eliminates Hammer	

Easily and quickly installed

Unequaled for Efficiency and Economy

Write for descriptive booklet

The New Stock Exchange Building (Morgan, Walls & Morgan, Architects) on Spring Street, between 6th and 7th Streets, Los Angeles (a 13-story office building of the very latest type) is equipped throughout with Schroeder Valves. We have many other installations that have stood the test of time and hard usage.

MADE BY

STANDARD METALS MANUFACTURING CO.

1300-1302 N. Main St.

Phone 66864

Los Angeles, Calif.

TiteSete Float Valve

For High and Low Pressures

IN SIZES UP TO 4 INCHES
 Larger Sizes on special order

Remains Wide Open
 until desired Water Level
 is reached then Closes
POSITIVELY without
 Water Hammer

Simple and Durable
 Positive and Reliable



Self-Cleaning,
 Non-Clogging
 By-Pass

NATIONAL VALVE COMPANY

Phone Douglas 5093

23-25 MINNA ST., SAN FRANCISCO

The Heart of the Kitchen

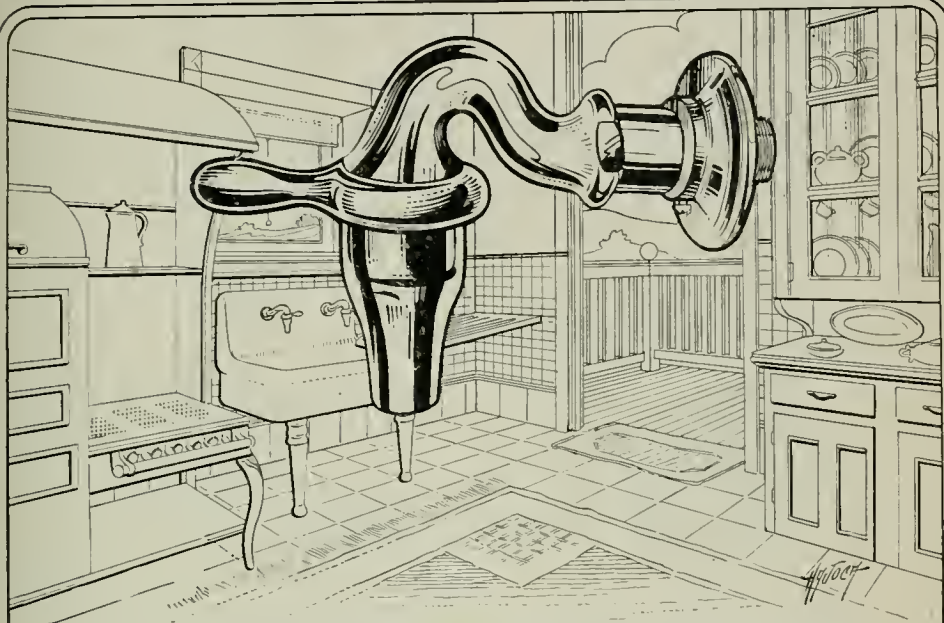

ONE of the most prominent Architect firms in San Francisco, and well known throughout the country, without solicitation on our part, wrote us as follows:

"We not only specify but insist on the plumber furnishing HAJOCA 'Quick' Faucets for all sinks in buildings constructed by us.

We consider everything from the rapid flowing stream to the simplicity of re-washing a delight to the user."

HAJOCA "Quick" Faucets are used not only on kitchen sinks, but shop sinks, laundry trays and factory wash sinks.

Many Architects, like the firm above quoted are standardizing their specifications on HAJOCA "Quick" Faucets.



HAINES, JONES & GADBURY Co.

MAKERS OF PLUMBING SUPPLIES

851 9 FOLSOM STREET, SAN FRANCISCO

PHILADELPHIA-NEW YORK-RICHMOND, VA.-SAVANNAH



IRON AND STEEL PRODUCTS

WAREHOUSE AND
MILL SHIPMENTS

STEEL BARS

for
CONCRETE
REINFORCING
FURNISHED AND
INSTALLED

EDW. L. SOULE' CO.
SAN FRANCISCO



SUTTER
2821

RIALTO
BUILDING

SERVICE

TESTING
INSPECTION
CONSULTATION
PRODUCTION

Structural and Engineering
Materials



Robert W. Hunt & Co.

Engineers

Chemical and Physical
Testing Laboratories

New York Chicago Pittsburgh
St. Louis San Francisco Mexico City
London Montreal

A PROPRIETOR BOUND HIMSELF

to maintain fire insurance for the amount paid by him to the contractor as the construction of the building progressed. The building was burned while in course of construction and the company denied liability on the ground that the proprietor had no insurable interest. The court held that the proprietor had an insurable interest in the building equal to the amount paid to the contractor.

DIXWELL DAVENPORT
Manager Pacific Coast Department

**BANKERS & SHIPPERS
INSURANCE COMPANY**
INSURANCE EXCHANGE BLDG.

SAN FRANCISCO
Telephone Kearny 3561

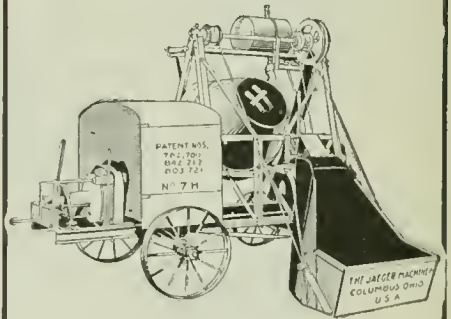

NOT ONLY MIXERS

but a full line of nationally-known equipment, as well.

We have prepared for a brisk building season.

"Get it from BACON"

Edward R. Bacon Company

51 Minna St., San Francisco

165 E. Jefferson St.
Los Angeles

Present Cost of Building Materials*

With Labor Wage Scale, Bonds, Etc.

THESE quotations are based on reliable information furnished by San Francisco material houses. Date of quotations, April 15, 1921.

All prices f. o. b. cars San Francisco or Oakland. For country work add freight and cartage to prices given.

American Institute of Architects' Fees

New work—6 per cent minimum basis.
Alterations—7 to 10 per cent as a minimum basis.

High class residence work—10 per cent as a minimum.

Bond—1½% amount of contract.

Brickwork—

Common, \$40.00 per 1000 laid.
Face, \$90.00 per 1000 laid.
Common, f. o. b. cars, \$18.00 plus cartage.
Face, f. o. b. cars, \$60.00 per 1000, car-load lots.

HOLLOW TILE FIREPROOFING

12x12x3 in., 10¼c. per square foot.
12x12x4 in., 11¼c. per square foot.
12x12x6 in., 16¼c. per square foot.
Hod carriers, \$8.00 per day.
Bricklayers, \$10.00 per day.
Lime—\$3.25 per bbl.; carload, \$2.75 per bbl.

Composition Floors—30c. per sq. ft.

Concrete Work (material at San Francisco bunkers)—

No. 3 rock.....\$2.50 per yd.
No. 4 rock..... 2.75 per yd.
Niles pea gravel..... 3.25 per yd.
Niles gravel..... 2.50 per yd.
Niles top gravel..... 3.00 per yd.
City gravel..... 2.50 per yd.
River sand..... 1.65 per yd.
Bank sand..... 1.00 per yd.

SAND

Del Monte, \$1.25 to \$1.50 per ton.
Fan Shell Beach, \$2.50 to \$3.00 per ton.
Car lots, f. o. b. Lake Majella.
Cement (f. o. b. cars).....\$3.69 per bbl.
Rebate for sacks, 15c each.
Atlas "White".....\$12.60 per bbl.
Medusa cement.....\$12.60 per bbl.
Forms.....\$30.00 per M

Wage—
Laborers.....\$7.05 per day
Concrete workers..... 7.50 per day
Cement finishers..... 8.35 per day

Dampproofing—

Two-coat work, 25c per yard.
Membrane waterproofing—4 layers of P. B. saturated felt, \$6.00 per square.
Hot coating work, \$2.00 per square.
WAGE—Roofers, \$9.00 per day.

Electric Wiring—\$8.00 to \$12.00 per outlet for conduit work (including switches).

WAGE—Electricians, \$10 and \$10.50 per day.
Knob and tube average \$4.50 to \$6.00 per outlet.

Elevators—

Prices vary according to capacity speed and type. Consult elevator companies.

Excavation—

\$2.00 per yard.
Teams, \$12.00 per day.
Trucks, \$30.00 to \$40.00 per day.
Above figures are an average without water.
Steam shovel work in large quantities, less; hard material, such as rock, will run consider-

Fire Escapes—

Ten-foot balcony, with stairs, \$100.00 per balcony.

Glass—(Consult with manufacturers.)

21 ounce, 20c per square foot.
Plate, \$1.40 per square foot.
Art, \$1.00 up per square foot.
Wire (for skylights), 44c per square foot.
Obscure glass, 28c per square foot.
Note.—Add extra for setting.
WAGE—Glaziers, \$7.85 per day.

Heating—

Average, \$2.00 per sq. ft. of radiation, according to conditions.
WAGE—Steamfitters, \$10.00 per day.

Iron—

Cost of ornamental iron, cast iron, etc., depends on design.

Lumber—(Prices delivered to bldg. site)

Common, \$34 per M (average).
Com'n O. P. (select), \$45 per M (average)

Flooring—

1x3 No. 1.....\$77.00 per 1000
1x3 No. 2..... 72.00 per 1000
1x4 No. 1..... 73.00 per 1000
1x4 No. 2..... 70.00 per 1000
1x4 No. 3..... 47.00 per 1000
1x6 No. 2 and better..... 73.00 per 1000
1¼x4 and 6 No. 2..... 75.00 per 1000
Slash grain, 1x4 No. 2..... 48.00 per 1000
Slash grain, 1x4 No. 3..... 39.00 per 1000
No. 1 common run to
T. & G. 35.00 per 1000
Lath..... 6.50 per 1000

Shingles—(Add cartage to prices quoted)

Redwood, No. 1.....\$1.00 per bdle.
No. 2..... .90 per bdle.
Red Cedar..... 1.10 per bdle.

Hardwood Floors—

Maple floor (laid and finished), 30c per foot.
Factory grade floors (laid and finished), 23c per foot.
Oak (quartered, finished), 40c per foot.
¾ Oak (clear), 30c per foot (plain).
¾ Oak (select), 28c per foot (plain).
¾ Oak, quartered, sawed, clear, 35c.
WAGE—Floor layers, \$10.00 per day.

Hardwood Floors (not laid)— Per M ft.

5/16x2" sq. edge Clear quartered oak.....\$220.00
Select quartered oak..... 162.50
Clear plain oak..... 147.50
Select plain oak..... 127.50
13/16x2¼" face Clear quartered oak..... 292.50
Select quartered oak..... 200.00
Clear plain oak..... 200.00
Select plain oak..... 180.00
Clear maple..... 160.00

THE ARCHITECT AND ENGINEER

Hardwood Floors (not laid)—Continued

	Per M ft.
13/16x3 1/4" face Clear maple.....	\$160.00
1 1/4x2 1/4" face Clear maple.....	160.00
3/8x2" face Clear quartered oak.....	215.00
Select quartered oak.....	160.00
Clear plain oak.....	147.50
Select plain oak.....	127.50
Clear maple.....	122.50

Millwork—

- O. P., \$100 and up per 1000. R. W., \$120 and up per 1000.
- Double hung box frame windows (average) with trim, \$7.50 and up each.
- Doors, including trim (single panel), \$10 and up each.
- Doors, including trim (five panel)\$9.00 each
- Screen doors, \$3.50 each.
- Window screens, \$1.50 each.
- Cases for kitchen pantries seven feet high, per lineal foot, \$9 each.
- Dining room cases, if not too elaborate, \$10 each.
- Labor—Rough carpentry, warehouse heavy framing, \$13.00 per 1000.
- For smaller work, average, \$21.00 to \$28.00 per 1000.
- WAGE—Laborers, \$6.50 per day.
- Carpenters, \$9.00 per day.

Marble—(Not set) add 60c up per ft. for setting

Columbia	\$2.05 sq. ft.
Alaska	2.05 sq. ft.
San Saba	3.65 sq. ft.
Tennessee	2.50 sq. ft.
Verde Antique	4.55 sq. ft.

Painting—

- Two-coat work, 40c per yard.
- Three-coat work, 52c per yard.
- Whitewashing, 5c per yard.
- Cold water paint, 9c per yard.
- Turpentine, \$1.07 per gal. in cases and 92c per gal in tanks.
- Raw Linseed oil, 94c per gal in barrels.
- Boiled Linseed oil, 96c per gal in bbls.
- Pioneer white and red lead, 11 3/4c lb. in one ton purchases; 12 1/2c lb. for less than 500 lbs.
- WAGE—Painters, \$8.35 per day.
- Note—Accessibility and conditions cause wide variance of costs.

Patent Chimneys—

6-inch	\$1.50 lineal foot
8-inch	1.75 lineal foot
10-inch	2.25 lineal foot
12-inch	3.00 lineal foot

Pipe Casings—\$8.00 each.

Plastering—

- Interior, on wood lath, 70c per yard.
- Interior, on metal lath, \$1.30 per yard.
- Exterior, on brick or concrete, \$1.30 per yard.
- Portland White, \$1.75.
- Interior on brick or terra cotta, 60c to 70c per yard.
- Exterior, on metal lath, \$1.85 to \$2.25 per yard.
- Wood lath, \$6.50 at yard per 1000.
- Metal studding, \$1.25 to \$1.50 per yard.
- Suspended ceiling and walls (metal furring, lathing and plastering), \$2.25 per yard.
- Galv. metal lath, 33c and up per yard, according to gauge and weight.

- Lime, f. o. b. warehouse, \$3.25 per bbl.
- Hardwall plaster, \$22.00 per ton, f. o. b. warehouse. (Rebate on sacks, 15c.)
- WAGE—Hod carriers \$9.00 per day.
- Plasterers, \$11.00 per day.
- Lathers, \$10 per day.

Plumbing—

- From \$70.00 per fixture up, according to grade, quantity and runs.
- WAGE—Plumbers, \$10.00 per day.

Reinforcing Steel—

- Base price for less than car load lots, \$4.25 per 100 lbs.
- Carload lots, \$4.00 per 100 lbs., f. o. b. San Francisco. (Mill delivery.)

Roofing—

- Five-ply tar and gravel, \$7.00 per square for 30 squares or over.
- Less than 30 squares, \$8.00 per square.
- Tile, \$35.00 to \$50.00 per square.
- Redwood shingle, \$10.00 per sq. in place.
- Cedar shingle, \$10.00 per square in place.
- Reinforced Pacco roofing, \$8.25 per square. WAGE—Roofers, \$8.35 per day.

Rough Hardware—

- Nails, per keg, \$5.70 base and very scarce.
- Deafening felt, \$170.00 per ton.
- * Building paper, P. & B.,
 - 1 ply, \$5.10 per 1000 ft. roll.
 - 2 ply, \$7.50 per 1000 ft. roll.
 - 3 ply, \$10.00 per 1000 ft. roll.
- Sash cord,
 - (Sampson spot), \$2.50 per hank 100 ft.
 - Common, \$1.35 per hank 100 feet.
- Sash weights, cast iron, \$70.00 per ton.

Sheet Metal—

- Windows—Metal, \$2.00 a square foot.

Skylights—

- Copper, \$1.25 a square foot (not glazed).
- Galvanized iron, 40c a square foot (not glazed).
- WAGE—Sheet metal workers, \$10.00 per day.

Store Fronts—

- Kawneer copper bars for store fronts.
- Corner, center and around sides, will average \$1.35 per lin. foot.
- Zouri bar, \$1.25 per lin. foot.
- Zouri Underwriters' Specification sash, \$1.60 per lin. foot.

Structural Steel—\$140.00 per ton (erected).

- This quotation is an average for comparatively small quantities.
- Light truss work higher; plain beam and column work in large quantities, less.

Steel Sash—

- Fenestra, from S. F. stock, 45c. per sq. ft.
- Fenestra, Plant shipment, 40 1/2c. per sq. ft. (Includes mullions and hardware.)
- Trus-con, from San Francisco stock, 40c to 45c per sq. ft.
- Trus-con, plant shipment, 35c to 42c per sq. ft.
- U. S. Metal Products Co., 40c per sq. ft. in San Francisco.

Tile—

- White glazed, 80c. per foot.
- White floor, 80c. per foot.
- Colored floor tile, \$1.00 per foot.
- Promenade tile, \$1.00 per sq. foot, laid.
- WAGE—Tilesetters, \$9.00 per day.

WILSON

2800 ROLLING STEEL DOOR

Chain Gear Operation

Standard for 45 years

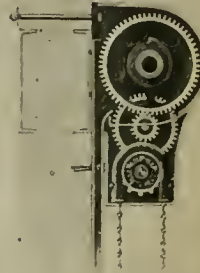
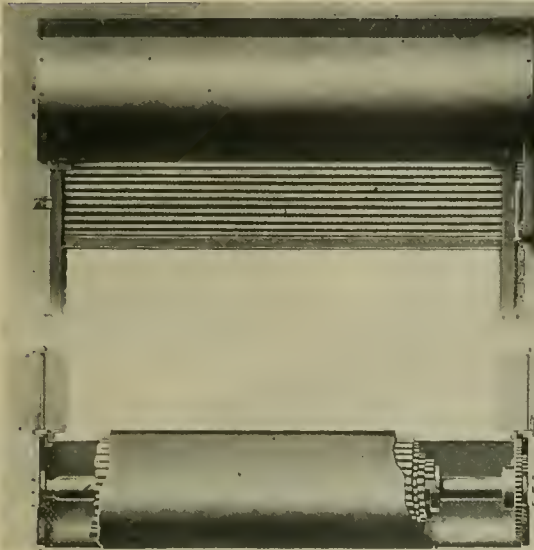

WILSON 2800
One of our
Standard
Designs

Coil placed on face of wall above Lintel with Grooves on face of Wall. "Big 4 Slats."

Adapted to openings 3x10 up to 20x25. Especially suitable for freight sheds, piers, driveways, etc.

Gearing protected from the weather insuring efficient operation. Openings over 14 feet wide may be fitted with safety grooves.

THE J. G. WILSON CORPORATION

Manufacturers of

Diffuselite Blinds and Awnings, Rolling Partitions, Rolling Steel Doors, Folding Partitions, School Wardrobes, Folding Casements

Pacific Coast Office and Factory:

621 N. Broadway, Los Angeles. Telephone 67189

Waterhouse-Wilcox Co., San Francisco; Theo. F. Snyder, San Diego; F. W. Farrington & Co., Portland; S. W. R. Dally, Seattle; Hawley-Richardson-Williams Co., Salt Lake City; Walter Dubree, Phoenix.

There is a Type of Store

ARMCO

TRADE MARK

INGOT IRON

Resists Rust

Look for this blue and gold label on Washing Machines, Refrigerators, Stoves, Enamelled Table Tops, and other household utilities.

"Armco" Ingot Iron is used and featured in such nationally advertised products as "Federal Washers," "Sanico Ranges," "Leonard Cleanable Refrigerators," "Buck's Stoves and Ranges," "Eden Washing Machines," "Globe Stoves and Ranges," and "Brascolites."

When writing to Advertisers please mention this magazine.

Where Armco Products Are Sold

THE man or woman who buys a refrigerator, a stove, or a washing machine made with "Armco" Ingot Iron is of a certain type.

The manufacturer who puts "Armco" Ingot Iron in his product must make a worthy article—must be a certain type of man—or he would use ordinary metal.

Even the merchant, the dealer who sells Armco products, can be classified generally by that very fact, for we know of no poor article made from this iron.

Therefore, the blue and gold Armco triangle carries with it an assurance of quality, of solid worth, wherever it is found.

The American Rolling Mill Company

Middletown, Ohio

Pacific Coast Sales Office, Tenth and Bryant streets, San Francisco. Other branch offices in New York, Chicago, Pittsburg, Cleveland, Detroit, St. Louis, Cincinnati, Atlanta, Washington, D. C., and Buffalo.

An ample stock of ARMCO Iron is carried at San Francisco Warehouse, Tenth and Bryant streets.

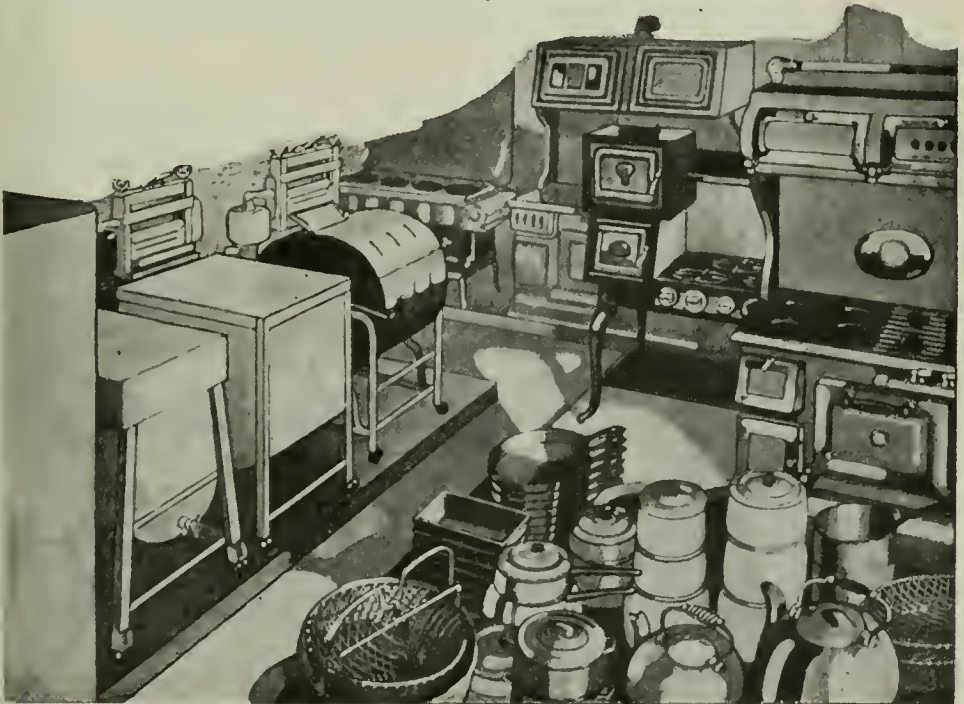

When writing to Advertisers please mention this magazine.

LARSEN-SAMPSON CO.

BUILDING CONSTRUCTION

Claus Spreckels Building

SAN FRANCISCO

DUNN SPRAY METHOD OF PAINTING

Saves Time, Labor and Material. Will outwear paint applied by other methods.

→ RONFLE Special Paints for Specific Purposes Used Unless Otherwise Specified.

PACIFIC PAINTING AND ROOFING COMPANY

G. D. NEWTON, Manager

PACIFIC BLDG., SAN FRANCISCO. 388 - 12th St., OAKLAND

CHAS. STOCKHOLM & SONS

GENERAL CONTRACTORS

849 MONADNOCK BUILDING Phone DOUGLAS 4657 SAN FRANCISCO

M. E. RYAN

Electrical Contractor

Phones: Store, Red. 250J
Residence, Red. 250M216 Main Street
REDWOOD CITY, CAL.

JOHN M. BARTLETT

GENERAL CONTRACTOR

Office
357 - 12th ST., OAKLANDPhone Lakeside 6750
Res. Phone Berkeley 6884W

E. T. LEITER & SONS

BUILDING CONSTRUCTION

412 CALL-POST BUILDING Phone SUTTER 1980 SAN FRANCISCO

Shop and Compare—that's the only true test
of values.Furnishings for the home of distinctive style are
featured in this shop at prices that will bear the
strictest comparison.

Furniture Draperies Floor Coverings Interior Decorations

John Breuner Co.
of *San Francisco*

281 GEARY STREET

SAMSON SPOT SASH CORD

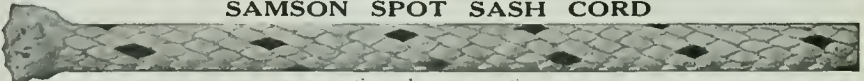

SPOT IT BY THE SPOTS

Made of extra quality cotton yarn, firmly braided and smoothly finished. Carefully inspected and
guaranteed free from all imperfections of braid and finish. → Can be distinguished at a glance
by our trade-mark, the Colored Spots. Send for catalogue and samples.

Pacific Coast Agent, JOHN T. ROWNTREE, Inc., San Francisco and Los Angeles, Cal.

The Elevator Floor

whether in Office Building, Hotel or Department Store, is subjected to a great deal of wear and tear.

— SPECIFY —

INTERLOCKING RUBBER TILING

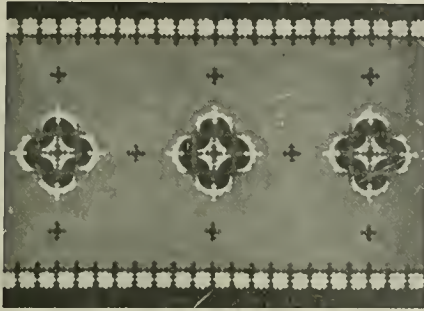

INTERLOCKING RUBBER TILING

material that is sure to give satisfaction. **Twenty tons installed in the Standard Oil Building, San Francisco.**
Stock on hand for immediate delivery.

and you've provided your client's building with a Durable, Economical, Practical,



New York Belting and Packing Co.

NEW YORK

San Francisco Branch 519 MISSION ST. Phone Douglas 1837

Small booklet of designs mailed on request.

Look for this
Trademark



And if it's there don't worry any more about your Valves and Fittings

Specify and insist upon having

**The Kelly & Jones Co.
Valves and Fittings**

**Byers Genuine
Wrought Iron Pipe**

Republic Steel Pipe

Complete Line of Plumbing Supplies
Large Stocks for Prompt Delivery
Catalogue on request

California Steam & Plumbing Supply Co.

671-679 Fifth Street, Corner Bluxome
SAN FRANCISCO, CALIFORNIA



**FOR MODERN
STORE FRONTS**

Plummer's Disappearing Awnings

Are constructed with no outside attachments below awning recess. All mechanical parts entirely concealed. Send for Architects' Sheet showing specifications for recess construction, etc.

W. A. PLUMMER MFG. CO., 35-37 Front Street, San Francisco

JOHN TRAYNOR

CHARLES HARCOURT

OCEAN SHORE IRON WORKS

Manufacturers of Boilers, Steel Tanks, Steel Plate Specialties.
Dealers in Boilers, Tanks, Pumps, Engines, Machinery, Etc.

We offer the following equipment for speedy disposal, subject to prior sale: 2—80-h. p. Horizontal Tubular Boilers, butt-strapped, 120 lb working pressure; 2—100 h. p. Heine Safety Water Tube Boilers, 130 lb W. P. 10—250 h. p. Marine Heine Cross Drum Water Tube Boilers; new; for marine or land use; 175 lb W. P. Prices on application. Send us your inquiries.

Office and Works:
550 EIGHTH STREET

SAN FRANCISCO, CAL.
Telephones: Market 462-463



Model No. 7A

NO GERMS HERE

HAWS IMPROVED SANITARY DRINKING FAUCET eliminates all possibility of contracting disease from dirty bulbs or unsanitary bowls. Provided with an overhead cowl, the drinker's lips never touch the source of supply. A slanting stream throws the water from right to left and away from the hubble, instead of straight up to fall back over the fountain head. Recommended for Schools and Public Playgrounds. A type used extensively by the U. S. Government. Manufactured by

Haws Sanitary Drinking Faucet Co., Inc.
1808 Harmon Street, Berkeley Phone Piedmont 3742

GLADDING, McBEAN & CO.

MANUFACTURERS CLAY PRODUCTS

CROCKER BUILDING, SAN FRANCISCO
WORKS, LINCOLN, CAL.

Heating and Ventilation

CONSULTING
Mechanical

ENGINEERS
Structural

MACHINE
DESIGN

INDUSTRIAL PLANT DESIGN

And

EQUIPMENT

376 Monadnock Bldg.
Phone Douglas 2945

San Francisco
California

Superintendents of Construction

Specifications and Estimates

RICHARD E. GUDERIAN
JOHN E. HAMILTON

THE TORMEY CO.

Phone Franklin
5-5-9-8

1042 Larkin St., San Francisco, Cal.

Alvaline, Cementoline

and other

Jones-Duncan Products

**MAGNER BROTHERS
PAINT MAKERS**

Telephone: Market 113
414-424 Ninth St. San Francisco

HEATING=PLUMBING

COMPLETE PLUMBING AND
HEATING SYSTEMS INSTALLED
IN ALL CLASSES OF BUILDINGS
ALSO POWER PLANTS

GILLEY-SCHMID CO., Inc.

198 OTIS STREET, SAN FRANCISCO.
Tel. MARKET 965

"BLAZING" THE TRAIL
We've been doing it for many years—giving the Sportsman Better Value for Quality than he ever before received. "Value at a Fair Price" in everything for the Sportsman.



SEND FOR CATALOG *The Sign of Quality*

Phone Douglas 3224

**Hunter & Hudson
ENGINEERS**

Designers of Heating, Ventilating
and Wiring Systems. Mechanical
and Electrical Equipment of
Buildings.

703 Rialto Bldg., San Francisco, Cal.

**BEAVER BLACKBOARD
BEAVER GREENBOARD**

SCHOOL FURNITURE
AND SUPPLIES—
OFFICE, BANK AND
COURTHOUSE FURNITURE—
THEATRE AND
AUDITORIUM SEATING

Rucker-Fuller Desk Co.

677 Mission St., SAN FRANCISCO, CAL.
434 Higgins Bldg., LOS ANGELES, CAL.
432 - 14th Street - OAKLAND, CAL.

NATIONAL ROOFING COMPANY

J. F. ELLIS

PACIFIC ROOFING COMPANY

J. B. McKEON

C. G. WILLIAMS

A. K. GOODMUNDSON

Members of

Builders and Roofers Exchange

2140 San Pablo Avenue, OAKLAND
Lakeside 271

RUSSWIN

BUILDERS' HARDWARE

JOOST BROS., Inc.

SAN FRANCISCO AGENTS.

We Carry Complete Stock:

Fishing Tackle—Guns—Mechanics' Tools—
Paints—Crockery and Glassware—Stoves—
Household Goods. Telephone Market 891.

NO BRANCH STORE

Mazda Lamps Electric Goods

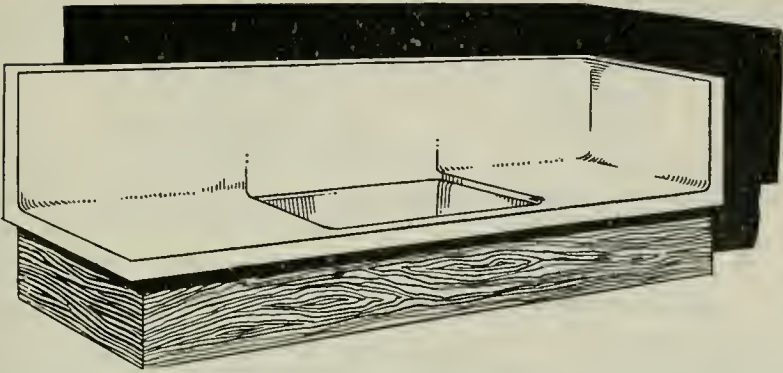

A Snow White Drain Board

PETRIUM SANITARY SINKS are made in Berkeley, California and are non-porous, non-absorbent and Lye-proof. The entire surface of the drainboard and back is covered with a composition, on which a smooth, glossy, snow white finish is applied mechanically leaving no crevice or corners in which dirt and grease can collect as where tile or wood is used.

Can be installed in any home—new or old.

PETRIUM SANITARY SINK COMPANY
 FACTORY AND OFFICE, WEST BERKELEY
 Agents in Principal Coast Cities

Send for booklet
 and Price List.

Building Apartment Houses Again

The records show a noticeable increase in the number of apartment houses for which contracts have been let this past month.

There is a tremendous demand for buildings of this type, strengthened by a return to normal prices. ¶ Conserve space by specifying .

Portal Wall Beds

MARSHALL & STEARNS CO.

WALL BEDS

Highest Award Always

1152 PHELAN BLDG., SAN FRANCISCO

1774 BROADWAY, OAKLAND

A. D. COLLMAN

P. F. SPEIDEL

COLLMAN AND SPEIDEL**GENERAL
CONTRACTING****CONSTRUCTION
ENGINEERS**

Telephone SUTTER 4858

MONADNOCK BUILDING, SAN FRANCISCO

I. R. KISSEL

Phone Franklin 548

Decorator, Painter and Paperhanger

1747 SACRAMENTO ST., Bet. Polk St. and Van Ness Ave., SAN FRANCISCO

ROBERT TROST

PHONE MISSION 2209

General Building ContractorWe Specialize in High Grade Work and Employ Skilled
Labor in every Branch of the Building Industry.26th and Howard Streets
SAN FRANCISCO

P. A. Palmer

Peter Petersen

W. L. Kelly

PALMER & PETERSEN**Contracting Engineers**

782-796 Monadnock Building

SAN FRANCISCO, CAL.

S. RASORI, RES. 2042 TAYLOR ST.
PHONE FRANKLIN 6258J. DEL FAVERO, RES. 1839 MASON ST.
PHONE FRANKLIN 9524**DEL FAVERO & RASORI****GENERAL CONTRACTORS**

MEMBERS OF THE S. F. BUILDERS EXCHANGE AND THE BUILDING INDUSTRIES ASS'N

OFFICE:
110 JESSIE STREET

SAN FRANCISCO, CALIF.

MONSON BROS.**GENERAL CONTRACTORS**

Telephone Market 2693

1908 Bryant Street, San Francisco

UNIT CONSTRUCTION COMPANY

(INCORPORATED)

ENGINEERING AND CONSTRUCTION

Telephone Kearny 28

429-36 Phelan Building, SAN FRANCISCO

J. D. HANNAH**Contractor and Builder**OFFICE: 142 Sansome Street
San Francisco, Cal.Telephone Douglas 3895
BUILDERS EXCHANGE, 180 JESSIE STREET

MOUNT DIABLO CEMENT
COWELL SANTA CRUZ LIME

ALL KINDS OF

BUILDING MATERIALS

HENRY COWELL LIME AND CEMENT CO.

Phone Kearny 2095

No. 2 MARKET STREET, SAN FRANCISCO

Automatic Fire Sprinklers

Protect your building and business from destruction by fire and reduce your Insurance Rate.

Pacific Fire Extinguisher Co.

FIRE PROTECTION ENGINEERS

424-440 HOWARD STREET
SAN FRANCISCO

MANUFACTURING PLANT
272 STEUART STREET

LINOTILE

“The Floor that’s Built to Fit the Room”

Furnished and Laid by

VAN FLEET-FREEAR CO.

Telephone :
Douglas 1227

61 New Montgomery Street
San Francisco, California

Kawneer

Factory
Berkeley, Calif.
Berkeley 8710

MANUFACTURING COMPANY
of California

San Francisco Office :
180 Jessie Street
Sutter 6700



Kawneer
Store-Fronts
All Metal Mouldings

Kawneer
Simplex Windows
Weightless & Reversible

I. M. SOMMER

CONTRACTOR & ENGINEER

Phone Kearny 4582

401 BALBOA BLDG., SAN FRANCISCO

K. E. PARKER COMPANY, Inc.

GENERAL CONTRACTORS

Phone Sutter 5661

Room 515 Clunie Building, SAN FRANCISCO

R. W. LITTLEFIELD BUILDING CONSTRUCTION

357 12th Street, Room 9, Oakland, Cal.

Phone Lakeside 6750

H. H. HILP, Jr.

J. FRANK BARRETT

BARRETT & HILP

CONCRETE CONSTRUCTION BUILDERS GENERAL CONTRACTORS

SHARON BUILDING, SAN FRANCISCO

TELEPHONE SUTTER 1168 or 1169

Res. Phone Mission 5049

JAMES F. SMITH — Plasterer

273 Minna Street, San Francisco

Phone KEARNY 740

Member Builders Exchange

STEELFORMS Signify ECONOMY, RAPIDITY, and EFFICIENCY

STEELFORM CONTRACTING COMPANY

STEELFORMS FOR
CONCRETE
BUILDINGS

C. B. Hopkins, C. E., Manager
681 Market Street, San Francisco

CONCRETE JOIST
FLOOR
CONSTRUCTION

W. C. DUNCAN & CO.

205 Sharon Bldg.

General Contractors

San Francisco

Telephone Kearny 772

M. E. VUKICEVICH

SPENCER B. BAGGE

VUKICEVICH & BAGGE GENERAL CONTRACTORS

Phone Sutter 6700

Office, Builders Exchange, 180 Jessie St., San Francisco

245 Market St.
S. F. Kearny 2028

Standard Fence Co.

310 Twelfth St.
Oakland 475

WIRE AND IRON WORKS

DESIGNERS - BUILDERS
FACTORY PROTECTION FENCE
AVIARY AND TENNIS COURT FENCE

WIRE GRILL WORK—WIRE SCREEN
FLEXIBLE WIRE CONVEYOR BELT
WIRE SPECIALTIES

320 North Los Angeles Street, Los Angeles, Cal. Phone 67188

Steel Bars

FOR CONCRETE REINFORCEMENT

Cut to Length, Fabricated, Installed

BADT-FALK & CO.

Tel. Douglas 3466

346 Call-Post Bldg., 74 New Montgomery St., San Francisco

BUILDING DIRECTORIES [INTERCHANGEABLE STEEL LETTERS AND NUMBERS]

FOR OFFICE BUILDINGS, SCHOOLS, CAFETERIAS, Etc.
Bargains Lists for Auto Sales Companies. Sold Outright.

Go-Sign and Letter Manufacturing Co.

1106 Franklin Street

Oakland, California

Phone FRANKLIN 689

MARTEN & FREDERICK

UNITED WORK SHOPS

Designers, Makers and Contractors of Fine Furniture, Draperies and Complete Interiors.

1374 SUTTER ST., SAN FRANCISCO

Phone Merritt 668

H. N. McNAB

Hardwood Floors



Floor Sanding

2307 - 17th Ave.

Oakland, Cal

Res. Tel. Merritt 3600

HERBERT BECKWITH

Building Construction

Formerly with
ARTHUR ARLETT

323 Newton Ave.
Oakland

D. ZELINSKY & SONS

PAINTERS AND DECORATORS

420 TURK STREET,

SAN FRANCISCO

CHARLES T. PHILLIPS

CONSULTING ENGINEER

PACIFIC BUILDING

SAN FRANCISCO

HEATING

VENTILATION

WIRING

ILLUMINATION

Ideal Air-Washers. Ideal Fruit-Dryers. Fan Systems for Heating, Cooling and Drying.

Ideal Heating and Engineering Co.

Air-Conditioning, Heating, Cooling and Drying

192 ERIE STREET

Phone Market 3708

SAN FRANCISCO

Atlas Heating and Ventilating Co., Inc.

ENGINEERS and CONTRACTORS

STEAM AND HOT WATER HEATING, FANS, BLOWERS,
FURNACES, POWER PLANTS--SHEET METAL WORK

Phone Douglas 378

Fourth and Freelon Sts., Bet. Bryant & Brannan, SAN FRANCISCO

Illinois Automatic Vacuum and Vapor Systems of Heating

"TWENTY-FIVE YEARS OF QUALITY"

ILLINOIS ENGINEERING COMPANY

JAS. I. KRUEGER, *Representative*

Pacific Building, San Francisco

Telephone: Sutter 7057

HEATING
VENTILATION

FLOOR AND WALL TILING

PLUMBING
SHEET METAL WORK

SCOTT CO., Inc.

SUCCESSOR TO JOHN G. SUTTON CO.

243 MINNA STREET

SAN FRANCISCO

ALEX COLEMAN

CONTRACTING PLUMBER

706 ELLIS ST., SAN FRANCISCO

Phone FRANKLIN 1006

WM. F. WILSON COMPANY

MODERN SANITARY APPLIANCES

Special Systems of Plumbing for Residences, Hotels, Schools, Colleges, Office Buildings, Etc.

Phone Sutter 357

328-330 Mason Street, San Francisco.

C. DRUCKER

J. C. JAMES

JAMES & DRUCKER

Plumbing—Heating Contractors

Phone Market 275

450 Hayes Street, San Francisco, Cal.

The Granite Work on Eldorado County Courthouse; National Bank of D. O. Mills, Sacramento;—
and Sen. Nixon Mausoleum, Reno, WAS FURNISHED BY

CALIFORNIA GRANITE COMPANY

Phone Sutter 2646

STONE CONTRACTORS

Builders' Exchange, San Francisco
Quarries, Rocklin and Porterville

Main Office, Rocklin, Placer Co., Cal.
Telephone Main 82

GOODS OF QUALITY

A new syphon action closet at a moderate price that is not only ultra-efficient but pleasing in appearance and combining many new sanitary features.

On display at our show room—

64 Sutter Street, San Francisco

Main office and warehouse: Sixth, Townsend & Bluxome Sts.



Holbrook, Merrill & Stetson

Designers - Fabricators - Erectors

General Plate Work



Hydro - Pneumatic Pressure Tanks —
Hemispherical Bottom Tanks and Towers
— Oil and Water Tanks — Oil Stills —
Pipe Lines—Smoke Stacks—Well Casing
— Rock Screens — "Western" Corru-
gated Culvert Pipe.

Western Pipe and Steel Company

OF CALIFORNIA

444 MARKET STREET
SAN FRANCISCO

1758 NORTH BROADWAY
LOS ANGELES



CEMENT GUN

Will Make Your
Concrete Waterproof

**Cement Gun Con-
struction Company**

of California

701 Balboa Building,
San Francisco

For
DAMS
RESERVOIRS
TUNNELS
BULKHEADS
CANAL
LININGS
CEMENT
FLUMES
use the
Cement Gun
—
SPEED
ECONOMY
PERMANENCE



LIGHT WEIGHT
FIREPROOF
EVERLASTING

STONE SHINGLES

VARIETY
and
DURABILITY
of COLORS

McCLENAHAN
PRODUCTS
COMPANY

670 Howard St.

INC.

San Francisco

QUEBRACHO!

One coat Argentine Quebracho paint on steel will out-wear three of red lead and graphite at fraction of cost. Contains South American gum that gives great tenacity. Ask about records on steel; also for damp-proofing concrete and for protecting piling from teredoes.

IMP MANUFACTURING CO.

732 Second St., Oakland Phone Lakeside 478

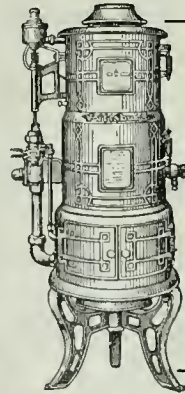

Pittsburg

It Insures
Instant
Hot Water
Service

**PITTSBURG WATER
HEATER COMPANY**

478 Sutter St., San Francisco
Phone Sutter 5025

**BUSINESS • SYSTEMS
OFFICE • FURNITURE**



F. W. Wentworth & Co.

539 MARKET ST., SAN FRANCISCO

DISTRIBUTORS FOR SALES ROOMS IN OAKLAND
LIBRARY BUREAU LOS ANGELES SEATTLE

WIRING



185 Stevenson Street, San Francisco
Phone Douglas 4832

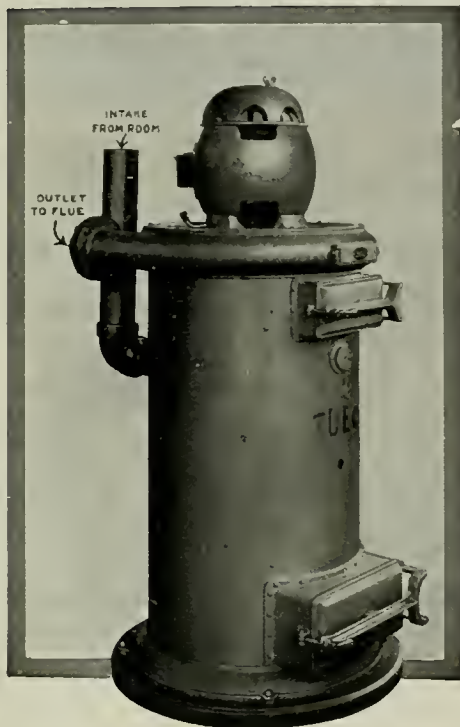

TUEC STATIONARY CLEANER

THE cleaner that reduces building maintenance expense by keeping floors, walls, stairways, merchandise and other stocks, carpets, furniture and furnishings free from dust and dirt. No other cleaning device or dust removal method is so thorough, efficient, and economical. Investigate yourself and invite your client to do so. Write for our free catalog and full information.

THE UNITED ELECTRIC CO.

CANTON, OHIO.

Canadian Plant: Toronto, Ont.

California Distributors

S. F. COMPRESSED AIR CLEANING CO.
397 Sutter Street, San Francisco

BARKER BROS.

724 S. Broadway, Los Angeles



POSITIVE ELECTRIC INTERLOCK

(BAR LOCK TYPE)

Prevents Elevator Accidents Occurring at the Entrance Door

Approved by National Underwriters Laboratories—Meets requirements of Elevator Safety Orders of Industrial Accident Commission, State of California

ELEVATOR SUPPLIES COMPANY, Inc. 186 FIFTH STREET,
SAN FRANCISCO

Capital \$1,000,000

CALIFORNIA DEPARTMENT

Surplus \$1,122,000

THE FIDELITY AND CASUALTY COMPANY OF NEW YORK

Prompt Service for

BONDS AND CASUALTY INSURANCE

203-206 Merchants Exchange Building

SAN FRANCISCO, CAL.

ANY PLACE ANY TIME PROMPTLY "We Serve You"
JOHN H. ROBERTSON

Successor to Robertson & Hall

GENERAL INSURANCE

Phone Sutter 2750

621 First National Bank Building, San Francisco

PACIFIC DEPARTMENT

Globe Indemnity Company

BONDS and CASUALTY INSURANCE for CONTRACTORS

FRANK M. HALL, formerly Robertson & Hall, Mgr.

120 Leidesdorff Street Phone Sutter 2280 SAN FRANCISCO

National Surety Company of New York

The World's Largest Surety Company

Assets over \$20,000,000

Pacific Coast Department: 105 MONTGOMERY ST., SAN FRANCISCO, CAL.

Frank L. Gilbert, Vice-President

Phone, Sutter 2636

School and Theatre

STAGES AND EQUIPMENT

EDWIN H. FLAGG

SCENIC COMPANY, Inc.
400 Pantages Bldg., San Francisco, Cal.
1638 Long Beach Ave., Los Angeles, Cal.

PHONE DOUGLAS 2370

McLERAN & PETERSON

GENERAL CONTRACTORS

HEARST BUILDING

SAN FRANCISCO, CAL.

L. J. RUEGG

J. B. RUEGG

RUEGG BROS.

CONTRACTORS AND BUILDERS

Phone Douglas 1599

719 Pacific Building, SAN FRANCISCO

OPEN HEARTH

Reinforcing Steel Bars

Square Deformed — Immediate Shipment — Cut to required lengths

PACIFIC COAST STEEL COMPANY

Sales Office, Rialto Building. SAN FRANCISCO. Phone Sutter 1564

Architects and Building Contractors!

The HICKS-JUDD COMPANY, Inc., and SUNSET PUBLISHING HOUSE
have consolidated under the name of
ABBOTT-BRADY PRINTING CORPORATION
460 Fourth Street, San Francisco, Calif.

THE Binding of Magazines and Periodicals
will continue as one of Our Specialties;
also Expert Plate and Map Mounting.

 Reprinting of The Architect and Engineer Advertisements for Circular or File Use

George S. MacGruer } Members of Builders Exchange
Robert M. Simpson }

MacGruer & Simpson**CONTRACTING PLASTERERS**

PLAIN AND ORNAMENTAL

Cement, Stucco and Artificial Stone

Phone Sutter 5688

540 Call-Post Building, San Francisco

**Detroit Jewel Gas Ranges**

FOR HOME, RESTAURANT, HOTEL AND CLUB

We carry a Full Line of Stock Sizes

SELLING AGENTS

NATHAN DOHRMANN CO.

Geary and Stockton Streets, San Francisco

PARMELEE-DOHRMANN CO.

436-444 S. BROADWAY, LOS ANGELES

CALIFORNIA ARTISTIC METAL & WIRE CO.
 J. T. McCORMICK, PRESIDENT
 ORNAMENTAL IRON AND BRONZE
 349-365 SEVENTH ST. SAN FRANCISCO

MORTENSON CONSTRUCTION CO.
 CONTRACTORS FOR STRUCTURAL STEEL AND IRON
 H. MORTENSON, PRES. CHAS. G. MORTENSON, VICE-PRES. AND MGR.
 OFFICE AND SHOPS: CORNER 19TH AND INDIANA STREETS
 PHONE: MISSION 5033 SAN FRANCISCO, CAL.

RAYMOND GRANITE COMPANY, Inc.
 Owning and operating at Knowles, Madera County, the largest Quarry in the world
 CONTRACTORS FOR STONE WORK
 Designers and Manufacturers of Exclusive Monuments and Mausoleums
 Main Office and Yard: No. 1 and 3 Potrero Avenue, San Francisco, California
 Also at 1350-Palmetto Street, Los Angeles

CAEN STONE  **A. KNOWLES**
 A refined, elegant, interior finish. CONTRACTOR and PLASTERER
 442 Call-Post Building San Francisco

ZOURI SAFETY SASH BARS
 Accepted by the Insurance Underwriters for Safety Setting of Plate Glass used in Store Front Construction.
 **COBBLEDICK-KIBBE GLASS CO.**
 175 JESSIE ST. WASHINGTON AT THIRD ST.
 SAN FRANCISCO, CAL. OAKLAND, CAL.

Telephone Mission 58 A. A. Devoto, President
CENTRAL IRON WORKS, Inc.
 STRUCTURAL STEEL
 Office 2050 BRYANT STREET SAN FRANCISCO, CAL.

JOHNS-MANVILLE
 SERVES IN CONSERVATION
 Through
ASBESTOS and its ALLIED PRODUCTS

 **SCHRADER IRON WORKS, Inc.**
 STRUCTURAL STEEL CONTRACTORS
 Fire Escapes, Waterproof Trap Doors, Ornamental Iron Work
 1247-1249 HARRISON STREET SAN FRANCISCO, CAL.
 Bet. 8th and 9th Telephone Market 337

THE HYLOPLATE BLACKBOARD

SCHOOL FURNITURE
AUDITORIUM SEATING

MAPS
GLOBES
ATLASES

C. F. WEBER & CO.

985 Market Street
SAN FRANCISCO

222-224

S. Los Angeles St.
LOS ANGELES

100 W. Commercial
Row, RENO, NEV.

524 W. Washington
Street, PHOENIX, ARIZ.

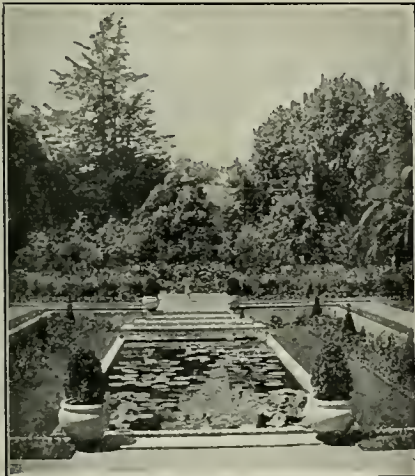

Formal Garden Effects

may be obtained on your Country Estate within a period of two or three years.

MacRORIE-McLAREN CO.

141 Powell Street, San Francisco

Telephone Douglas 4442

Durability

Redwood gives the best service for all industrial construction, especially where exposed to the elements or in contact with the ground.

Nature impregnates Redwood with a natural preservative that resists rot. Redwood lasts longer untreated than most woods when artificially preserved.

Write for "Redwood Lives Forever," "California Redwood for the Engineer," and "Redwood Block Paving and Flooring."

CALIFORNIA REDWOOD ASSOCIATION
San Francisco

California Redwood

Resists fire and rot

THE HEART OF A BUILDING IS ITS PIPING EQUIPMENT

A complete line for the Piping Features of Buildings—Power, Plumbing, Heating, Ventilating, Refrigerating, Vacuum-Cleaning, Gas, Water, etc.—is furnished by Crane Co. through the Plumbing and Heating trade.

The Architect, Engineer and Builder, or Investor, may enjoy, through the facilities of this Company, the distinct advantage of dealing entirely with one Competent and Responsible House.

Exhibit Rooms, Offices and Warehouses in San Francisco and Oakland and Fifty-one other cities.

CRANE CO.

1855-1918



VALVES AND
FITTINGS



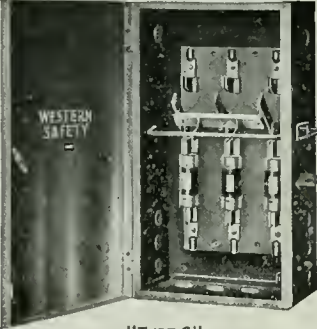

Western Safety Man'fg. Co. Inc.
Formerly
MEYERS ELECTRIC SAFETY SWITCH CO., Inc.

Manufacturers of
Enclosed Externally Operated Safety
Switches, Knife Switches, Metal Switch
and Cut Out Boxes, Safety Switch Boards

Office, 247 Minna Street SAN FRANCISCO
Telephone, Sutter 3008

"TYPE C"

Telephone
DOUGLAS
2046

Butte Electrical Equipment Company

BEECO

TRADE MARK - REG.

530
FOLSOM
STREET

**CONTRACTORS FOR POWER LIGHTING
AND INDUSTRIAL INSTALLATIONS**

For the convenience and guidance of our customers,
we have adopted BEECO as our trade name.

SAFETY ELECTRIC COMPANY

MANUFACTURERS OF

<p>SWITCHBOARDS SAFETY SWITCHES SAFETY CONTROLS</p>		<p>PANEL BOARDS SAFETY PANELS KNIFE SWITCHES</p>
---	---	--

59-65 Columbia Square San Francisco, Calif.
Telephone Market 2949

L. SIEBERT J. GENSLER

Drendell Electrical & Mfg. Co.

Incorporated

SWITCHBOARDS, PANEL BOARDS, KNIFE SWITCHES,
CABINETS, THEATRE INSTALLATIONS,
PROTECTIVE POWER PANELS

1345-1353 Howard St., San Francisco Telephone Market 1753

BUTTE ELECTRIC & MFG. CO. DOUGLAS 145

(Paul C. Butte) at it since 1904
WIRING FOR BUILDINGS

534 Folsom Street

SAN FRANCISCO

H. S. TITTLE

CONTRACTING ELECTRICAL ENGINEER

766 FOLSOM ST., SAN FRANCISCO

Phone SUTTER 4278



To Be "Low Bidder" Not Always Our Aim.

Our most particular attention is given to prompt and skillful handling of all electrical work of any nature with "QUALITY AND SERVICE GUARANTEED."

Our nation-wide organization and large experience in this field assures you always of fair estimates and absolute satisfaction.

F. E. NEWBERY ELECTRIC CO.

163 Sutter St. (413 Lick Bldg.) San Francisco, Phone Sutter 521

San Francisco, Cal.

Oakland, Cal.

Los Angeles, Cal.

NEPAGE, McKENNY CO.

Electrical Engineers and Contractors

Phone Sutter 2369

589 Howard St., San Francisco, Cal.

Phone Market 2541

M. FLATLAND

GLOBE ELECTRIC WORKS

Estimates Furnished on Everything Electrical

ELECTRIC SUPPLIES

1959 Mission Street, bet. 15th and 16th

SAN FRANCISCO



Browne-Langlais Electrical Construction Co.

Agents for

ROBBINS and MYERS MOTORS PACKARD MAZDA LAMPS

213 MINNA STREET, SAN FRANCISCO

Telephone Douglas 976

G. WALTER SPENCER, Manager

Phone Lakeside 6750

SPENCER ELECTRIC CO.

CONTRACTING AND ENGINEERING

355 TWELFTH STREET

OAKLAND, CALIF.

CHAS. G. FRIES.

TELEPHONE SUTTER 5706

VICTOR A. KUEHN

LIBERTY ELECTRIC COMPANY

479 Sutter St. **Electrical Contractors** San Francisco, Cal.

Oakland 540

The Largest Exclusive Electrical House in the State

MOTORS

BOUGHT — SOLD
RENTED — REPAIRED

Lighting Fixtures

Manufactured

Construction

MAINTENANCE
SUPPLIES

Estimates and engineering data cheerfully furnished

SPOTT ELECTRICAL CO.

Yours for Service

16th & CLAY STREETS

OAKLAND, CALIFORNIA

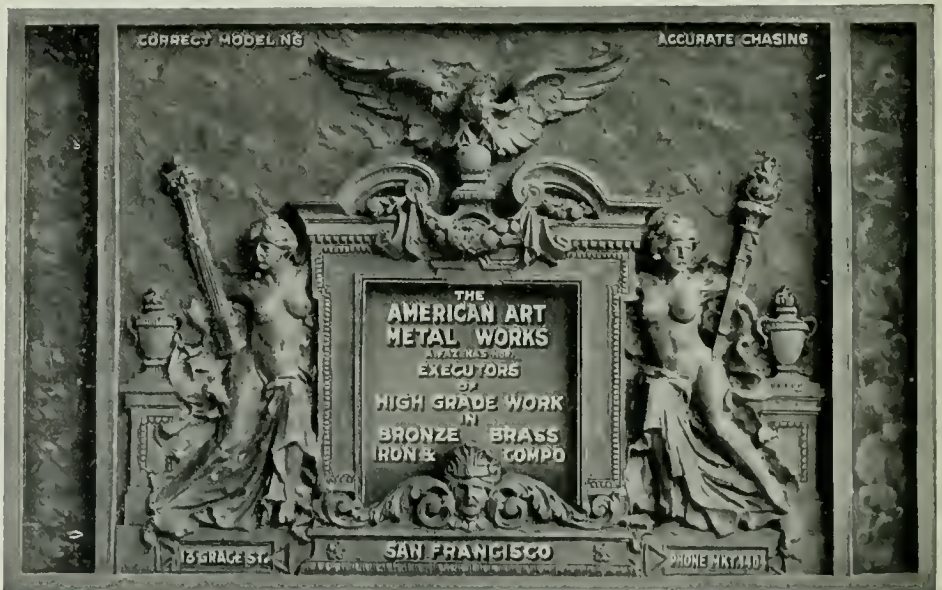

When writing to Advertisers please mention this magazine.

A. H. Bergstrom
Eric Lange

S. F. Phone Kearny 3526

LANGE & BERGSTROM

Building Contractors

(Established 1900)

207-210 SHARON BLDG.
San Francisco

WASHINGTON BLDG.
Los Angeles

TIMKEN BLDG.
San Diego

CONTRACTOR'S MACHINERY

RANSOME MIXERS

OSHKOSH MIXERS

INSLEY SPOUTING PLANTS

OSHKOSH EVEREADY SAW RIGS INSLEY STEEL CARS and TRACKS

HOISTING BUCKETS, HOPPERS, GATES, ETC.

STEAM AND ELECTRIC HOISTS

EVERYTHING USED BY CONTRACTORS

CARRIED IN STOCK BY

GARFIELD & CO.

Hearst Building, San Francisco

Phone Sutter 1036

Lakewood Building Mixers

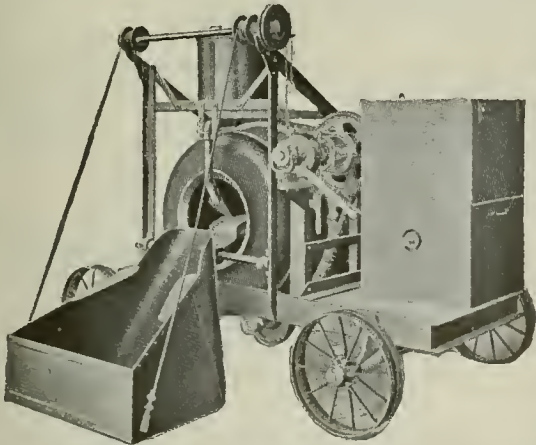

are in a class by themselves, as evidenced by repeated demands for these machines from large corporations and our most successful contractors. All merchantable sizes in stock—a complete line of equipment—steam, gasoline or electric power.

SMITH-BOOTH-USHER CO.

MACHINERY, SUPPLIES, PIPE AND FITTINGS

Factory Distributors

SAN FRANCISCO
50 - 60 Fremont Street

LOS ANGELES
228-238 Central Avenue

LANNOM BROTHERS MFG. CO.

Hardwood Interior
Finish a Specialty

MILL WORK, SASH and DOORS

Veneered Doors
and Panels

Telephone Oakland 241

Fifth and Magnolia Sts., Oakland

MILLWORK Manufactured and Delivered Anywhere

Plans or Lists sent us for Estimates will have Careful and Immediate Attention.

Jno. Dudfield, Pres.
and Manager

DUDFIELD LUMBER CO. Joseph A. Jury,
Sec'y & Mill Supt.

MAIN OFFICE, YARD AND PLANING MILL — PALO ALTO, CALIFORNIA

FRANK PORTMAN MILL AND CABINET WORK

Window Frames and Inside Finish A Specialty
Band Sawing, Sticking and Sand Papering

1618-20 MISSION STREET

SAN FRANCISCO

ALL KINDS OF
MOULDINGS
IN STOCK

Phone Park 6204

A. C. SCHINDLER, President.

CHAS. F. STAUFFACHER, Secretary

THE FINK & SCHINDLER CO.

Manufacturers of INTERIOR WOODWORK AND FIXTURES
BANK, OFFICE AND STORE FITTINGS
SPECIAL FURNITURE

218-228 THIRTEENTH ST
Bet. Mission and Howard Sts.

SAN FRANCISCO, CAL.
Telephone: Market 474

O. BAMANN, President

ERNEST HELD, Vice-President

HOME MANUFACTURING CO.

BANK, STORE AND OFFICE FITTINGS
FURNITURE AND HARDWOOD INTERIORS
CABINET WORK OF EVERY DESCRIPTION

543 and 545 BRANNAN ST.

Phone Kearny 1514

San Francisco, Cal.

MULLEN MANUFACTURING CO.

BANK, STORE AND OFFICE FIXTURES—CABINET WORK OF
GUARANTEED QUALITY—CHURCH SEATING

Telephone Market 8692

Office and Factory:
64 Rausch St., Bet. 7th and 8th Sts., San Francisco

JAMES L. McLAUGHLIN

GENERAL CONTRACTOR

Phone Kearny 4654

251 KEARNY STREET, SAN FRANCISCO

Dolan Wrecking & Construction Co.

(D. J. DOLAN)

Lumber, Lath, Nails, Shingles, Doors, Windows
and Plumbing Supplies, New and Second Hand

Phone Market 4264

Office and Yard, 1607-1639 MARKET ST., SAN FRANCISCO

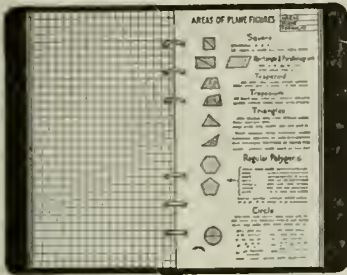

LEFAX

LEAF + FACTS

Pocket Cyclopedias

The facts that you want *instantly available* are not the same ones that some one else in your profession might desire. That's why LEFAX is made Loose Leaf. You file, in whatever order you wish, those sheets of facts that you want to have constantly at hand. If you wish, you may also file, in the same book, sheets for keeping data, for figuring, etc.

LEFAX sets cost but 50c. and \$1.00. You cannot fully appreciate their handiness—their value—until you use them. Ask us about them.

SCHWABACHER - FREY STATIONERY CO.
 PRINTERS LITHOGRAPHERS STATIONERS
 611 Market Street San Francisco

Steam Heating and Ventilating

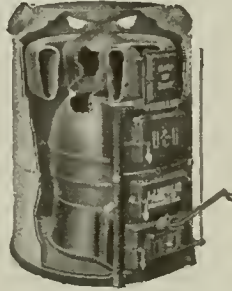

For Commercial and Public Buildings

Furnace Heating
 For the Home

Mangrum & Otter, Inc.

827-831 Mission Street
 Phone Kearny 3155 SAN FRANCISCO

"Talk—Don't Walk"

Baker, Hamilton & Pacific Co.; California Packing Corporation; J. Barth & Company; Robert Dollar Company; Bass-Hueter Paint Co.; Sperry Flour Company, So. Vallejo; J. D. & A. B. Spreckles Securities Co.

WHY are the above firms using the AUTOMATIC PRIVATE TELEPHONE SYSTEM?

BALFOUR, GUTHRIE Co.; HOWARD AUTOMOBILE COMPANY; U. S. MARINE HOSPITAL KNOW WHY, and are also installing the AUTOMATIC PRIVATE TELEPHONE SYSTEM.



DIRECT-LINE TELEPHONE COMPANY

Telephone Electrical Engineers

THEODORE HALL, MANAGER

320 MARKET STREET, SAN FRANCISCO
 Phone Douglas 722

Have you read "A Pair of Wires and A Dial?"

ROBERTS MFG. CO.

Lighting Fixtures
 Electric Appliances
 Incandescent Lamps

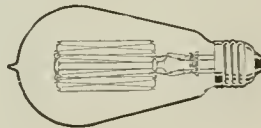

WILLYS FARM LIGHTING AND POWER PLANTS

663 Mission St., San Francisco

Washed Gravel and Sand

Quality For Concrete Construction *Service*

Thoroughly Washed and Accurately Graded—An Ideal Concrete Aggregate



View of Plant at Niles

California Building Material Co.

Plants at Eliot and Niles, Cal.

500 Call Building, San Francisco

Otis Elevators

THE Architect or Engineer can specify "Otis Elevators" assured that the responsibility of the Otis Elevator Company extends beyond satisfactory installation. Buildings equipped with Otis Elevators enjoy the advantage of the prompt service and careful inspection rendered by any of our hundred offices. Such service means your clients' gratitude.



Otis Elevator Company

Offices in All Principal Cities of the World
2300 Stockton Street, San Francisco, Calif.

The
ARCHITECT &
ENGINEER



MAY 1921

Published in San Francisco
50 cents a copy - \$2⁵⁰ a year



Resume

“The only way to resume, is to resume,” said Lincoln, when confronted with a great problem.

And, the only way for this country to start to catch up on its building program is — to start.

We all have a part to play in encouraging building.

“The only way
to resume-is
to resume”

Abraham Lincoln

PACIFIC **PLUMBING FIXTURES**

For Sale by All Jobbers

OFFICES: 67 NEW MONTGOMERY STREET, SAN FRANCISCO
FACTORIES: SAN PABLO AND RICHMOND, CALIFORNIA





*New Salinas Union High School
Covered with a PABCO 20-Year Roof.*

Salinas Union High School
Salinas, Cal.

Ralph Wyckoff,
Architect

Maloti and Peterson,
Roofing Contractors

PABCO ROOFS for Schools

Great progress has been made in the West in the design and construction of school buildings. Architects and School Boards now aim to combine beauty and permanence with maximum utility. And where first quality materials are specified, PABCO ROOFS are included.

PABCO 10 and 20-Year Roofs

appeal to Architects, Engineers and owners because of the high quality of materials, the proved method of construction, and particularly because they are least expensive due to the *low cost per year of service.*

Write for Specifications and
Complete Details

THE PARAFFINE COMPANIES, Inc.
San Francisco



Roofings—Felts
Roof Coatings
Building Papers
Floor Covering
Wall-Boards
Waterproofing
Materials
Paints
Box-Board
Paper Boxes
Fibre Containers



New Home
BANK OF ITALY

San Francisco, Calif.

BLISS & FAVILLE,
Architects

We will install in the Bank of Italy the most complete and best Electric Clock System west of Chicago.

**Self-winding Master Clock,
Marble Dial Secondary
Clocks,
Electric Time Recorders,
Electric Time Stamps.**

Plans, specifications and any engineering information, estimates, etc., cheerfully furnished to architects, engineers or any one interested in this special line of work.

PACIFIC ELECTRIC CLOCK CO.

J. J. ESTABROOK

516 Wells Fargo Building,
San Francisco, Calif.

Telephone Sutter 809

General Machinery & Supply Co.

OFFICES AND STORE: 39-51 STEVENSON STREET
TELEPHONE - PRIVATE EXCHANGE - SUTTER 6750

— AGENTS FOR —

EVERLASTING BLOW-OFF VALVES

WM. POWELL CO.'S { WHITE STAR VALVES - MODEL STAR VALVES
UNION COMPOSITE DISC VALVES AND PILOT GATE VALVES

YALE & TOWNE:—CHAIN HOISTS

FISHER AND SWARTWOUT STEAM SPECIALTIES

ENGINEER'S, MACHINIST'S AND STEAM FITTER'S SUPPLIES
PIPE, PIPE-FITTINGS, VALVES, BELTING, PACKING AND HOSE
TRANSMISSION AND CONVEYING MACHINERY

SEND US YOUR INQUIRIES

Compare These Lavatories



• Old Style



All-in-One Lavatory

BOTH lavatories are of the same type, the popular priced lavatory so much in use in the average bathroom of today: both sell for the same price—but in all other respects they are entirely different.

The old style lavatory has exposed metal parts and pipes underneath—the All-in-One Lavatory has no exposed metal parts, the entire fixture being finished in white enamel. The old style lavatory has two outlets, one for hot water and one for cold—the All-in-One, only one outlet with a special mixing device that blends the hot and cold water, enabling one to wash in running water of the correct temperature. The old style lavatory has a plug and chain—the All-in-One, a patented waste plug with spring and cap.

The All-in-One Lavatory eliminates all of these exposed metal parts and connecting joints by casting the hot and cold water inlets, waste pipe, overflow integral, faucets and soap cup with the fixture itself. It can be installed much more quickly than the old style fixture as there is only one connection to be made. It is much more attractive and is far easier to keep clean—and it costs no more than the old style lavatory.

All-in-One Lavatories are made in all the different styles. All-in-One Bathtubs are designed on the same principle and are made in all sizes and styles. Let us send you Free illustrated catalog fully describing All-in-One Plumbing Fixtures.

All-in-One Company

504 Marsh-Strong Building, Los Angeles

Dept. A

When Choosing Electric Time Equipment you certainly want **THE BEST.**

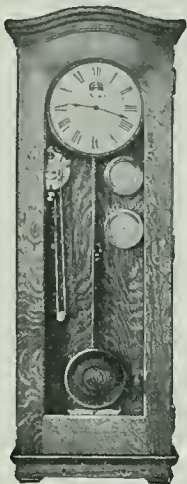

"Standard" electric time equipment watches over the precious minutes of school days, preventing too much time being used for one subject at the expense of another, simplifying the whole school routine and promoting punctuality and efficiency among both pupils and teachers. Perfected through 36 years' experience. Each equipment carefully engineered to fit requirements. Helpful co-operation furnished architects, contractors, and school boards, insuring satisfaction.

STANDARD ELECTRIC TIME COMPANY

461 MARKET STREET

Phone Sutter 241 SAN FRANCISCO

DEPENDABILITY

"Since 1858"

LINOLEUMS
WINDOW SHADES

Carpets
Draperies
Rugs

Estimates Furnished

D. N. & E.

Walter & Co.

562-572 Mission Street
SAN FRANCISCO

Los Angeles Portland Seattle



PROMETHEUS

The Electric Food and Plate Warmer

Wherever meals are cooked and served, in apartments, residences and institutions, Prometheus is a highly valued asset. The wireless heating units placed independently of the shelves keep food hot and tasty until ready to serve and cannot injure the finest china.

Write for information and list of installations

The Prometheus Electric Co.

Manufacturers

511 West 42d Street, New York

Showroom, **M. E. HAMMOND**
Mezzanine Floor Pacific Bldg., San Francisco



IT'S not enough to say "Good For All Time" unless there is something back of it. ¶ There is in this case. ¶ Vermont Marble already has an unblemished record of over one hundred and fifty years. ¶ We know what it will do. It's not necessary to guess at it. ¶ And our quarries in Alaska and Texas are also proving themselves. ¶ So please don't think of "Good for All Time" as merely a happy phrase.

IT'S THE MARK OF A SERVICE.
It means exactly what it says.

Vermont Marble Company
PROCTOR, VERMONT

San Francisco - Portland - Tacoma

STEEL BARS

FOR

CONCRETE REINFORCEMENT

CORRUGATED
TWISTED
SQUARES
OR
ROUNDS
CUT
TO
LENGTH



FABRICATED
AND
INSTALLED
—
LUMP SUM
BIDS
ON
WORK
COMPLETE

Office, 444 MARKET STREET
Warehouse, 10th and Bryant Streets
Phone: Sutter 2720

“HYDRATITE” FOR WATERPROOFING AND HARDENING CONCRETE “HORNSTONE”

How daylight helps workmen do more and better work

DAYLIGHT and fresh air are powerful aids to production. The stimulus of plenty of light and fresh air is reflected in greater volume and accuracy of output, with diminished wastage. Operatives enjoy better health, are freer from eye-strain, lose fewer days through sickness. Labor turnover is reduced—output is noticeably increased. All of this is accomplished with TRUSCON Daylight Sash.

Truscon Daylight Engineers at your Service

All sizes of Truscon Steel Sash carried in stock in San Francisco Warehouse.

Largest stock of fireproof material and reinforcing bars on the Pacific Coast.

TRUSCON STEEL COMPANY

CHAS. HOLLOWAY, JR., Branch Manager

527 Tenth Street, San Francisco

TRUSCON DAYLIGHT SASH

E. B. Noble, President
A. E. Wilkins, Vice-Pres.

Beam, Angle, Channels, and Universal Mill
Plates for immediate shipment from stock

Pacific Rolling Mill Co.

SUPPLIERS OF

FABRICATED STRUCTURAL STEEL, Forgings,
Bolts, Rivets, Frogs, Switches, Cast Iron Castings

General Office and Works
17th and MISSISSIPPI STS., SAN FRANCISCO
Telephone Market 215

Beams
Channels
Angles
Plates



Steel Wheel-
barrows in
Stock

Western Iron Works

W. B. MORRIS, Pres. H. H. MORRIS, V.-P. L. J. GATES, Sec.

STRUCTURAL IRON AND
STEEL CONTRACTORS

141-147 Beale St. and 132-148 Main St. SAN FRANCISCO

Phones: GARFIELD 2575--2576

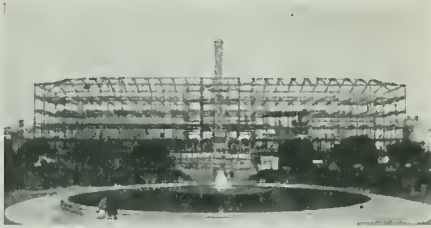

Bliss & Faville, Architects

Steel Frame, California
State Building, Civic Center,
San Francisco.

FABRICATED BY

THE PALM IRON AND
BRIDGE WORKS (Incorporated)

15th and R Streets, Sacramento

Cast Iron Stairs and Store Fronts

Bank and Office Railings, Elevator
Enclosures and Fire Escapes.

C. J. HILLARD CO., Inc.

Nineteenth and Minnesota Streets
Telephone Mission 1763

SAN FRANCISCO, CAL.

Architects' Specification Index

(For Index to Advertisements, see next page)

ART METAL

American Art Metal Works, 13 Grace street,
San Francisco.

ARCHITECTURAL TERRA COTTA

Gladding, McBean & Company, Crocker Bldg.,
San Francisco.

Tropico Potteries, Inc., Glendale, Cal.

ASBESTOS ROOFING, PACKING, ETC.

H. W. Johns-Manville Co., San Francisco, Los
Angeles and Portland, Ore.

AUTOMATIC SPRINKLERS

Grinnell Co. of the Pacific, 453 Mission St., San
Francisco.

Pacific Fire Extinguisher Co., 424 Howard St.,
San Francisco.

AUTOMOBILE INSURANCE

Bankers & Shippers Insurance Co. of New York,
Insurance Exchange Bldg., San Francisco.

AUTOMOBILES

W. L. Hughson Co., Geary St., at Van Ness Ave.,
San Francisco.

AWNINGS, TENTS, ETC.

W. A. Plummer, Front, at Pine St., San Fran-
cisco.

BANKS

First National Bank, Post and Montgomery
streets, San Francisco.

BANK FIXTURES AND INTERIORS

Fink & Schindler, 218 13th St., San Francisco.

C. F. Weber & Co., 985 Market St., San Fran-
cisco.

Home Mfg. Co., 543 Brannan St., San Fran-
cisco.

Mullen Manufacturing Co., 64 Rausch St., San
Francisco.

Rucker-Fuller Desk Co., 677 Mission St., San
Francisco.

Pacific Manufacturing Company, San Francisco,
Los Angeles, Oakland and Santa Clara.

BELTING AND PACKING

New York Belting and Packing Company, 519
Mission St., San Francisco.

H. N. Cook Belting Co., 401 Howard St., San
Francisco.

Smith-Booth-Usher Co., San Francisco and Los
Angeles.

BLACKBOARDS

C. F. Weber & Co., 985 Market St., San Fran-
cisco, Los Angeles and Reno, Nevada.

Beaver Blackboards and Greenboards, Rucker-
Fuller Desk Company, Coast agents, 677 Mis-
sion St., San Francisco; also Oakland and
Los Angeles.

BLINDS—VENETIAN AND DIFFUSELITE

J. G. Wilson Corporation, Metropolitan Bldg.,
Los Angeles; Waterhouse-Wilcox, Underwood
Bldg., San Francisco.

Western Venetian Blind Co., Long Beach Ave.,
Los Angeles; C. F. Weber & Co., San Fran-
cisco.

BOILERS

California Hydraulic Engineering & Supply Co.,
70-72 Fremont St., San Francisco.

General Boilers Co., 322 Monadnock Bldg., San
Francisco.

Kewanee Water Supply System, Simonds Ma-
chinery Co., 117 New Montgomery St., San
Francisco.

BOOK BINDERS

Abbott-Brady Printing Corp'n, 460 Fourth St.,
San Francisco.

H. S. Crocker Co., 565 Market St., San Fran-
cisco.

BONDS FOR CONTRACTORS

American Mutual Liability Insurance Co., Balboa
Bldg., San Francisco.

Bonding Company of America, Kohl Bldg., San
Francisco.

Bankers & Shippers Insurance Co. of New York,
Insurance Exchange Bldg., San Francisco.

Globe Indemnity Co., 120 Leidesdorff St., San
Francisco.

Fidelity & Casualty Co. of New York, Merchants
Exchange Bldg., San Francisco.

John H. Robertson, 621 First National Bank
Building, San Francisco.

National Surety Co. of New York, 105' Mont-
gomery St., San Francisco.

BRASS GOODS, CASTINGS, ETC.

H. Mueller Manufacturing Co., 635 Mission St.,
San Francisco.

BRICK, PRESSED, PAVING, ETC.

Los Angeles Pressed Brick Co., Frost Bldg., Los
Angeles.

United Materials Co., Crossley Bldg., San Fran-
cisco.

Cannon & Co., Sacramento; and 77 O'Farrell
street, San Francisco.

BRICK & CEMENT COATING

Armorite and Concreta, manufactured by W. P.
Fuller & Co., all principal Coast cities.

The Paraffine Companies, Inc., 34 First St., San
Francisco.

R. N. Nason & Co., 151 Potrero Ave., San
Francisco.

Wadsworth, Howland & Co., Inc., Boston, Mass.,
manufacturers of Bay State Brick & Cement
Coating. Hambley & Son, agents, San Fran-
cisco and Los Angeles.

BRICK STAINS

Samuel Cabot Mfg. Co., Boston, Mass., agencies
in San Francisco, Oakland, Los Angeles, Port-
land, Tacoma and Spokane.

Armorite and Concreta, manufactured by W. P.
Fuller & Co., all principal Coast cities.

BUILDERS' HARDWARE

Joost Bros., agents for Russell & Erwin Hard-
ware, 1053 Market St., San Francisco.

The Stanley Works, New Britain, Conn., repre-
sented in San Francisco and Los Angeles by
John Rountree & Co.

Palace Hardware Company, Agents Corbin goods,
581 Market St., San Francisco.

Richards-Wilcox Mfg. Co., Aurora; Ewing-Lewis
Co., 626 Underwood Bldg., San Francisco.

GRINNELL AUTOMATIC SPRINKLER GRINNELL COMPANY

OF THE PACIFIC

ENGINEERS AND CONTRACTORS

453 Mission Street, San Francisco

CHEMICAL FIRE
EXTINGUISHERS
and FIRE ENGINES

VALVES
PIPE and FITTINGS

When writing to Advertisers please mention this magazine.

An Index to the Advertisements

	Page		Page		Page
Abbott-Brady Printing Corp.	151	Globe Indemnity Co.	150	Pacific Pump & Supply Co.	38
All-in-One.	3	Ginnell Co.	7	Pacific Rolling Mills.	6
American Art Metal Works.	22	Gunn Carle Company.	5	Palace Hardware Co.	38
American Face Brick Ass'n.	129	Haines, Jones & Cadbury.	131	Palm Iron Works.	6
American Insulex Co.	36	Hamilton, John E.	132	Palmer & Petersen.	142
American Mutual Liability Insurance Co.	10	Hannab, J. D.	142	Paraffine Companies, Inc.	1
American Mail Chute.	28	Hauer Window Co.	36	Parker, K. E. Co., Inc.	144
American Marble & Mosaic Co.	44	Haws Sanitary Drinking Faucet Co.	138	Petrium Sanitary Sink Co.	20-21
American Rolling Mill Co.	133	Hill, Hubbell Co.	124	Phillips, Chas. T.	145
American Window Glass Co.	42	Hillard, C. J., Co.	6	Pitcher Door Hanger.	33
Anderson, V. A.	17	Holbrook, Merrill & Stetson.	147	Pittsburg Water Heater Co.	148
Atherly Bros.	145	Home Mfg. Co.	158	Plummer, W. A.	138
Atlas Heating & Ventilating Co.	146	Hoosier Store.	20-21	Pope & Talbot.	15
Atlas Portland Cement Co.	123	Hughson, W. L. Co.	26	Portman, Frank.	158
Bacon, Edward R., Co.	119	Humphrey Radiant Fire.	25	Prometheus Electric Co.	4
Badt-Falk & Co.	145	Hunt, Robt. W. & Co.	132	Raymond Granite Co.	152
Baird-Bailhache Company.	34	Hunter & Hudson.	140	Reliance-Grant Elevator Equipment Co.	22
Bankers' & Shippers' Ins. Co.	153	Ideal Heating & Engineering Co.	146	Richard Wilcox.	31
Barrett & Hip.	144	Illinois Engineering Co.	146	Roberts Mfg. Co.	159
Bartlett, John M.	136	Imp Mfg. Co.	148	Robertson Co., H. H.	151
Bass-Hueter Co.	3rd Cover	Imperial Waterproofing.	28	Robertson, John H.	150
Beach-Robinson Co.	27	James & Drucker.	146	Ruegg Bros.	150
Beckwith, Herbert.	145	Jarvis, T. P. Mfg. Co.	43	Rucker-Fuller Desk Co.	140
Bowser & Co., S. F.	41	Johns-Manville Co.	152	Ryan, M. E.	136
Brenner, John.	136	Johnson, S. T.	43	Safety Electric Co.	154
Brinister Co.	22	Johnson Service Co.	11	Sampson Spot Cord.	136
Browne-Langlais Company.	155	Joost Brothers.	140	Santa Fe Lumber Co.	15
Builders and Roofers Exchange.	140	Kawneer Mfg. Co.	143	Scott Co.	146
Bunting Iron Works.	43	Kerner Incinerator Co.	42	Schradr Iron Works.	152
Butte Electrical Equipment Co.	154	Kissel, I. R.	142	Schwabacher-Frey Co.	159
Butte Electric & Mfg. Co.	155	Knittle-Cashe Co., Inc.	13	Simmons, O. M. Co.	12
Cabot, Samuel (Inc.)	41	Knowles, A.	152	Simonds Machinery Co.	127
California Artistic Metal and Wire Co.	152	Lannom Bros. Mfg. Co.	158	Smith-Booth-Usher Co.	157
California Bldg. Material Co.	160	Lange & Bergstrom.	157	Smith, Jas. F.	144
California Brick Co.	33	Larson Sampson Co.	145	Sommer, J. M.	144
California Granite Co.	136	Leiter, E. T. & Son.	136	Sonneborn Sons, Inc.	125
California Hydraulic Engineering and Supply Co.	10	Liberty Electric Co.	155	Sonnenschein Bros.	27
California Steam and Plumbing Supply Co.	137	Littlefield, R. W.	144	Soulé, Edward L. Co.	132
Cannon & Co.	24	Los Angeles Pressed Brick Co.	128	Spencer Electric Co.	155
Cement Gun Construction Co.	148	MacGruer & Simpson.	151	Spencer Elevator Co.	34
Central Electric Co.	148	MacRorie-McLaren Co.	153	Spot Electrical Co.	141
Central Iron Works.	152	Magner Bros.	140	Standard Metal Mfrs.	130
Cobbleck-Kibbe Glass Co.	152	Mangrum & Otter.	159	Standard Varnish Works.	117
Coleman, Alex.	146	Marshall & Stearns Co.	141	Standard Electric Time Co.	4
Collman & Spedel.	142	Marten & Fredericks.	145	Standard Fence Co.	145
Commercial Export and Import Co.	138	McClenahan Products Co.	148	Stanley Works, The.	113
Cook Belting Co.	38	McCray Refrigerator Co.	28	Steelform Contracting Co.	144
Cowell Lime & Cement Co.	143	McLaughlin, Jas. L.	158	St. Francis Hotel.	127
Crane Co.	153	McLeran & Peterson.	150	Stockholm, Chas. & Son.	136
Crocker, H. S. Co.	121	Meese & Gottfried.	118	Strable Hardwood Co.	37
Davis, R. J.	9	Moline Heat.	16	Sunset Lumber Company.	15
Del Favero and Rasori.	142	Montague Range & Furnace Co.	18	Tay Company, George H.	26
Del Monte Properties Co.	29	Monson Bros.	142	Taylor Galleries.	27
Detroit Steel Products Co.	44	Mortenson Construction Co.	152	Tittle, H. S.	155
Dolan Wrecking & Construction Co.	158	Mott Co. of Calif.	18	Torney Co.	140
Drendell Elec. & Mfg. Co.	154	Mueller Mfg. Co.	18	Tropico Potteries, Inc.	24
Dudfield Lumber Co.	158	Mullen Mfg. Co.	158	Trost, Robt.	142
Duncan, W. C.	144	Mushet Co., W. E.	149	Truscon Steel Co.	5
Dunham, C. A. Co.	31	Musto Sons Keenan Co.	13	Uhl Bros.	38
Electric Appliance Co.	126	Myers & Schwartz.	32	Unit Construction Co.	142
Electric Sales Service Co.	12	Nason, R. N. & Co.	9	United Blower Co.	146
Elevator Supplies Co.	150	Nathan, Dohrmann Co.	151	United Electric Co.	156
Ellery Arms Co.	140	National Mill & Lumber Co.	33	United Materials Co.	128
Fess System Co.	43	National Surety Co.	150	U. S. Metal Products Co.	36
Fidelity & Casualty Co. of N.Y.	150	National Terra Cotta Society.	115	U. S. Steel Products Co.	40
Fink & Schindler Co., The.	158	National Valve Co.	130	Vermont Marble Co.	4
First National Bank.	118	National Window Shade Co.	149	Vukicevich & Bagge.	144
Flagg, Edwin H., Scenic Co.	150	Nelson, James A.	18	Wadsworth, Howland & Co., Inc.	119
Freeman Art Shop.	27	Ne Page, McKenny Co.	155	Walter, D. N. & E. Co.	4
Fuller & Goepf.	34	Newbery Electric Co.	155	Wayne Oil Tank & Pump Co.	29
Fuller, W. P. Co.	23-30	New York Belting and Packing Co.	137	Wayne, J. F. Co.	122
Garfield Company.	157	Norris Co., L. A.	28	Weber, C. F. & Co.	153
Garnett Young & Co.	139	Oak Flooring Mfrs' Ass'n.	19	Wentworth, F. W.	148
General Boilers Co.	139	Ocean Shore Iron Works.	138	West Coast Porcelain Co.	Back Cover
General Gas Light Co.	25	Old Mission Portland Cement Co.	35	Western Blind & Screen Co.	39
General Machinery & Supply Co.	2	Otis Elevator Co.	160	Western Safety Mfg. Co.	154
Gilley-Schmid Co.	140	Pacific Coast Steel Company.	151	Western Iron Works.	6
Gladling, McBean & Co.	24	Pacific Electric Clock Co.	2	Western Pipe and Steel Co.	147
Globe Electric Works.	155	Pacific Fire Extinguisher Co.	143	White Bros.	112
		Pacific Gas and Electric Co.	143	Wilson, J. G., Corp.	134-135
		Pacific Mfg. Co.	15	Wilson, W. F. Co.	146
		Pacific Materials Co.	44	Witt, G. E. Co.	44
		Pacific Painting and Roofing Co.	136	Zelinsky, D. & Sons.	145
		Pacific Plumbing Fixtures, 2d Cover.	136		
		Pacific Porcelain Ware Co., 2d Cover.	136		

Nason's Opaque Flat Finish

A Flat Washable Oil Paint, made in soft Kalsomine tints—a practical article for Walls, Ceilings, Etc. Agency for Tamm & Nolan Company's High Grade VARNISHES and FINISHES, made on the Pacific Coast to stand our climatic conditions.

R. N. NASON & CO. Paint Makers
151 Potrero Ave.—436 Market St., San Francisco—Portland-Seattle-Oregon

ARCHITECTS' SPECIFICATION INDEX—Continued

- BUILDING MATERIALS, SUPPLIES, ETC.**
Pacific Materials Co., Underwood Bldg., San Francisco.
Waterhouse-Wilcox Co., 523 Market St., San Francisco.
Johns-Manville Company, Post and Mason Sts., San Francisco.
- CABINET MAKERS**
Home Manufacturing Company, 543 Brannan St., San Francisco.
Fink & Schindler Co., 218 13th St., San Francisco.
Mullen Manufacturing Company, 64 Rausch St., San Francisco.
Lannom Bros. Mfg. Co., 5th and Magnolia sts., Oakland.
Pacific Mfg. Co., San Francisco, Los Angeles and Oakland.
Frank Portman, 1618 Mission St., San Francisco.
- CARPETS**
W. & J. Sloane, 216-228 Sutter St., San Francisco.
John Breuner Co., 281 Geary St., San Francisco.
D. N. & E. Walter, Mission near Second street, San Francisco.
- CASEMENT WINDOW HARDWARE**
Richards-Wilcox Mfg. Co., Aurora, Ill., and Underwood Bldg., San Francisco.
- CEMENT**
Atlas Portland Cement Co., all principal cities.
Mt. Diablo, sold by Henry Cowell Lime & Cement Co., 2 Market St., San Francisco.
Medusa White Portland Cement, manufactured by Sandusky Cement Co., represented in San Francisco by Pacific Building Materials Co., Underwood Bldg., San Francisco.
Old Mission Portland Cement Co., Mills Building, San Francisco.
- CEMENT EXTERIOR WATERPROOF PAINT**
Armorite, sold by W. P. Fuller & Co., all principal Coast cities.
Bay State Brick and Cement Coating, manufactured by Wadsworth, Howland Co., Boston, Mass. James Hambley & Son, Distributors, San Francisco and Los Angeles.
Hill, Hubbell & Company, No. 1 Drumm St., San Francisco.
Imperial Waterproofing, manufactured by Brooks & Doerr, Reed Baxter, agent, Merchants National Bank Bldg., San Francisco.
Medusa White Portland Cement, manufactured by Sandusky Cement Co., represented in San Francisco by Pacific Materials Co., 525 Market St., San Francisco.
- CEMENT GUN**
Cement Gun Construction Company of California, 701 Balboa Bldg., San Francisco.
- CEMENT TESTS—CHEMICAL ENGINEERS**
Robert W. Hunt & Co., 251 Kearny St., San Francisco.
- CLAY PRODUCTS**
California Brick Company, 604 Mission street, Cannon & Co., Sacramento, Cal.
Gladding, McBean & Co., Crocker Bldg., San Francisco.
Los Angeles Pressed Brick Co., Frost Bldg., Los Angeles.
Tropico Potteries, Inc., Glendale, Cal.
- United Materials Co., Sharon Bldg., San Francisco.
- CLOCKS—ELECTRIC TIME**
Pacific Electric Clock Co., 516 Wells-Fargo Bldg., San Francisco.
Standard Electric Time Co., 461 Market St., San Francisco.
- COLD STORAGE PLANTS**
H. W. Johns-Manville Co., Post and Mason Sts., San Francisco.
T. P. Jarvis Crude Oil Burning Co., 275 Connecticut St., San Francisco.
- COMPRESSED AIR CLEANERS**
United Electric Co., Canton, O., mfr. of Tuec Cleaner, sold by San Francisco Compressed Air Cleaning Co., Sutter and Stockton Sts., San Francisco.
George H. Tay Company, Mission and Second Sts., San Francisco; 10th and Harrison Sts., Oakland.
- CONCRETE CONSTRUCTION**
Barrett & Hilp, Sharon Bldg., San Francisco.
Clinton Construction Co., 140 Townsend street, San Francisco.
K. E. Parker Co., Inc., Clunie Bldg., San Francisco.
Palmer & Petersen, Monadnock Bldg., San Francisco.
I. M. Sommer, 401 Balboa Bldg., San Francisco.
Steelform Contracting Company, 681 Market St., San Francisco.
- CONCRETE HARDENER**
Gunn, Carle & Co., Inc., 444 Market street, San Francisco.
- CONCRETE MIXERS**
Foote and Jaeger mixers sold by Edward R. Bacon Co., 51 Minna St., San Francisco, also Los Angeles.
Ransome mixers sold by the Garfield Co., Hearst Bldg., San Francisco.
Smith-Booth-Usher Co., San Francisco and Los Angeles.
- CONCRETE REINFORCEMENT**
Edw. L. Soule Co., Rialto bldg., San Francisco.
United States Steel Products Co., San Francisco, Los Angeles. Portland and Seattle.
Twisted Bars. Sold by Gunn, Carle & Co., Inc., 444 Market St., San Francisco.
Clinton Welded Wire Fabric, L. A. Norris Co., 140 Townsend St., San Francisco.
Pacific Coast Steel Company, Rialto Bldg., San Francisco.
Triangle Mesh Fabric. Sales agents, Pacific Materials Co., 525 Market St., San Francisco.
Truscon Steel Co., 527 Tenth St., San Francisco.
Badt-Falk Co., Call-Post Bldg., San Francisco.
- CONDUITS**
Garnett Young & Co., 612 Howard St., San Francisco.
- CONTRACTORS, GENERAL**
Barrett & Hilp, Sharon Bldg., San Francisco.
K. E. Parker Co., Inc., Clunie Bldg., San Francisco.
R. W. Littlefield, 357 12th St., Oakland.
Unit Construction Co., Phelan Bldg., San Francisco.
J. D. Hannah, 142 Sansome St., San Francisco.

R. J. Davis
District Sales
Agent

Century

**A. C. Motors
and Fans**

Complete stocks carried at: 171-173 Second St., San Francisco; 906 So. Hope St., Los Angeles

We have returned to our policy-holders annually for 33 years never less than 30% of the premium as a dividend. Dividends declared during 1919, \$2,017,893.

AMERICAN MUTUAL LIABILITY INSURANCE CO. OF BOSTON

Assets \$8,654,667

Surplus \$1,417,173

WORKMEN'S COMPENSATION, AUTOMOBILE, TEAMS AND PUBLIC LIABILITY INSURANCE

SAN FRANCISCO BRANCH OFFICE

1816 Balboa Building. Telephone Kearny 3202

N. F. Hesseltine, California Manager.

C. H. Gray, Assistant Manager.

ARCHITECTS' SPECIFICATION INDEX—Continued

CONTRACTORS, GENERAL—Continued

- John M. Bartlett, 357 Twelfth St., Oakland.
- E. T. Leiter & Son, Call-Post Bldg., San Francisco.
- Chas. Stockholm & Son, Monadnock Bldg., San Francisco.
- Herbert Beckwith, 323 Newton Ave., Oakland.
- Collman & Speidel, 546 Monadnock Bldg., San Francisco.
- Clinton Construction Company, 140 Townsend St., San Francisco.
- Monson Bros., 1907 Bryant St., San Francisco.
- W. C. Duncan & Co., 526 Sharon Bldg., San Francisco.

- A. Knowles, Call-Post Bldg., San Francisco.
- T. B. Goodwin, 180 Jessie St., San Francisco.
- Lange & Bergstrom, Sharon Bldg., San Francisco.
- McLeran & Peterson, Hearst Bldg., San Francisco.
- Robert Trost, 26th and Howard Sts., San Francisco.
- I. M. Sommer, 401 Balboa Bldg., San Francisco.
- Del Favero & Rasori, 180 Jessie St., San Francisco.
- Jas. L. McLaughlin, 251 Kearny street, San Francisco.

CONTRACTORS' EQUIPMENT

- Edward R. Bacon Co., 51 Minna St., San Francisco, and Los Angeles.
- Garfield & Co., Hearst Bldg., San Francisco.
- Smith, Booth-Usher Co., 60 Fremont St., San Francisco; 228 Central Ave., Los Angeles.

CONTRACTORS' INSURANCE

- Bankers & Shippers Insurance Co. of New York, Insurance Exchange Bldg., San Francisco.

CONVEYING MACHINERY

- Meese & Gottfried, San Francisco, Los Angeles, Portland and Seattle.

CORK TILE, INSULATION, ETC.

- Van Fleet-Freear Co., Sharon Bldg., San Francisco.

CRUSHED ROCK

- Coast Rock & Gravel Co., Call-Post Bldg., San Francisco.

DAMP-PROOFING COMPOUND

- Armorite Damp Resisting Paint, made by W. P. Fuller & Co., San Francisco.
- Gunn, Carle & Co., Inc., 444 First street, San Francisco.
- Hill, Hubbell & Company, No. 1 Drumm St., San Francisco.
- Imperial Waterproofing, mfrd. by Brooks & Doerr, Reed Baxter, agent, Merchants National Bank Bldg., San Francisco.
- "Pabco" Damp-Proofing Compound, sold by Paraffine Co., 34 First St., San Francisco.

DOOR HANGERS

- Pitcher Hanger, sold by National Lumber Co., 326 Market St., San Francisco.
- Reliance Hanger, sold by Waterhouse-Wilcox Co., San Francisco; D. F. Fryer & Co., B. V. Collins, Los Angeles, and Columbia Wire & Iron Works, Portland, Oregon.
- Stanley Works, New Britain, Conn. John Rountree, agent, Monadnock Bldg., San Francisco.
- Richards-Wilcox Mfg. Co., Underwood Bldg., San Francisco.

DRINKING FOUNTAINS

- Haws Sanitary Drinking Faucet Co., 1808 Harmon St. Berkeley, and C. F. Weber & Co., San Francisco and Los Angeles.

- Crane Company, San Francisco, Oakland, and Los Angeles.
- Pacific Porcelain Ware Co., 67 New Montgomery St., San Francisco.

- George H. Tay Company, Mission and Second Sts., San Francisco; 10th and Harrison Sts., Oakland.

- Haines, Jones & Cadbury Co., 857 Folsom St., San Francisco.

DUMB WAITERS

- Spencer Elevator Company, 166 7th St., San Francisco.

- M. E. Hammond, Pacific Bldg., San Francisco.

ELECTRICAL CONTRACTORS

- Butte Electrical Equipment Company, 530 Folsom St., San Francisco.

- Butte Electric & Manufacturing Co., 534 Folsom St., San Francisco.

- Brown-Langlais Electrical Construction Co., 213 Minna St., San Francisco.

- Central Electric Company, 185 Stevenson street, San Francisco.

- NePage, McKenny Co., 589 Howard St., San Francisco.

- Liberty Electric Company, 479 Sutter St., San Francisco.

- Newbery Electrical Co., 413 Lick Bldg., San Francisco.

- Pacific Fire Extinguisher Co., 424 Howard St., San Francisco.

- Globe Electric Works, 1959 Mission St., San Francisco.

- M. E. Ryan, Redwood City, Calif.

- H. S. Tittle, 766 Folsom St., San Francisco.

- Spencer Electric Co., 355 12th street, Oakland.

- Scott Electrical Co., Sixteenth and Clay Sts., Oakland.

ELECTRIC PLATE WARMER

- The Prometheus Electric Plate Warmer for residences, clubs, hotels, etc. Sold by M. E. Hammond, Pacific Bldg., San Francisco.

ELECTRICAL SUPPLIES AND EQUIPMENT

- Garnett Young & Co., 612 Howard St., San Francisco.

- Butte Electrical Equipment Co., 530 Folsom St., San Francisco.

- Electric Outlet Co., Inc., 119 West 40th St., New York.

- Safety Electric Company, 56-65 Columbia Square, San Francisco.

- Drendell Electrical & Mfg. Co., 1345 Howard St., San Francisco.

- R. J. Davis, District Sales Agent, Century A. C. Motors and Fans, 171 Second St., San Francisco.

- Western Electric Safety Mfg. Co., Inc., 247 Minna street, San Francisco.

ELEVATORS

- Otis Elevator Company, Stockton and North Point, San Francisco.

- Spencer Elevator Company, 166 7th St., San Francisco.

ELEVATOR EQUIPMENT

- Elevator Supplies Company, Inc., 186 Fifth St., San Francisco.

KEWANEE
GARBAGE BURNERS
AND
BOILERS

YEOMANS
BILGE PUMPS
EJECTORS
HOUSE PUMPS

OVERHEAD
CARRYING
SYSTEMS

CALIFORNIA HYDRAULIC ENGINEERING & SUPPLY CO., 80 Fremont St., S. F.

TEMPERATURE REGULATION**JOHNSON SERVICE COMPANY**

(OF MILWAUKEE — ESTABLISHED 1885)

Manufacturers and Installers of **JOHNSON Heat Humidity CONTROL**

For schools, residences, hospitals, banks, public buildings, also canneries and all kinds of industrial plants—Hot water tank regulators, air and water reducing valves.

Rialto Bldg, SAN FRANCISCO 605 Van Nuys Bldg., LOS ANGELES

**ARCHITECTS' SPECIFICATION INDEX—Continued****ENGINEERS—CONSULTING, ELECTRICAL, MECHANICAL**

Chas. T. Phillips, Pacific Bldg., San Francisco.
Hunter & Hudson, Rialto Bldg., San Francisco.

ELEVATOR DOOR HARDWARE

Richards-Wilcox Mfg. Co., Underwood Bldg., San Francisco.

FAIENCE TILE

Tropico Potteries, Inc., Glendale, Cal.

FANS AND BLOWERS

Ideal Heating & Engineering Co., 192 Erie St., San Francisco.
John Ringins Co., Inc., 1267 Folsom street, San Francisco.

FENCES—WIRE

Standard Fence Construction Co., 245 Market St., San Francisco, and 310 12th St., Oakland.

FILLING STATION EQUIPMENT

S. F. Bowser & Co., Inc., 612 Howard St., San Francisco.
Wayne Oil Tank & Pump Co., 631 Howard St., San Francisco, 830 S. Los Angeles St., Los Angeles.

FIRE BRICK

Livermore Fire Brick Works, 604 Mission street, San Francisco.

FIRE ESCAPES

Palm Iron & Bridge Works, Sacramento.
Western Iron Works, 141 Beale St., San Francisco.
Golden Gate Iron Works, 1541 Howard St., San Francisco.

FIRE INSURANCE

Bankers & Shippers Insurance Co., Insurance Exchange Bldg., San Francisco.

FIRE PROOFING

American Insulex Company, Berkeley Bank Bldg., Berkeley.

FIRE-PROOF DOORS

Forderer Cornice Works, 269 Potrero avenue, San Francisco.
U. S. Metal Products Co., 330 10th street, San Francisco.
Fire Protection Products Co., 3117 20th street, San Francisco.

FIRE SPRINKLERS—AUTOMATIC

Grinnell Company, 453 Mission St., San Francisco.
Pacific Fire Extinguisher Co., 424 Howard St., San Francisco.

FIRE RETARDING PAINT

The Paraffine Companies, Inc., 34 First St., San Francisco.

FIXTURES—BANK, OFFICE, STORE, ETC.

Home Manufacturing Company, 543 Brannan St., San Francisco.
The Fink & Schindler Co., 218 13th St., San Francisco.
Mullen Manufacturing Co., 64 Rausch St., San Francisco.
C. F. Weber & Co., 985 Market St., San Francisco, and 210 N. Main St., Los Angeles, Cal.

FLOOR TILE

Mangrum & Otter, 827 Mission St., San Francisco.

FLOOR VARNISH

Bass-Hueter and San Francisco Pioneer Varnish Works, 816 Mission St., San Francisco.

Fifteen for Floors, made by W. P. Fuller & Co., San Francisco.

Standard Varnish Works, Chicago, New York and San Francisco.

R. N. Nason & Co., San Francisco and Los Angeles.

FLOORS—HARDWOOD

Oak Flooring Manufacturers' Association of the United States, Ashland Block, Chicago, Ill.
Parrott & Co., 320 California St., San Francisco.
White Bros., Fifth and Brannan Sts., San Francisco.

Strable Hardwood Company, 511 First street, Oakland.

FLOORS—MASTIC

Hill, Hubbell & Company, No. 1 Drumm St., San Francisco.

FLOORS—DUST PROOF CEMENT

L. Sonneborn Co., United Materials Co., San Francisco agents.

FLUMES

California Corrugated Culvert Co., West Berkeley, Cal.

FLUSH VALVES

National Valve Company, 23-25 Minna St., San Francisco.

FRUIT DRYING MACHINERY

Ideal Heating & Engineering Co., 192 Erie St., San Francisco.

Jas. A. Nelson, 517 Sixth St., San Francisco.

FUEL OIL SYSTEMS

S. T. Johnson Co., 1337 Mission St., San Francisco.

S. F. Bowser & Co., Inc., 612 Howard St., San Francisco.

Wayne Oil Tank & Pump Co., 631 Howard St., San Francisco.

FURNACES—WARM AIR

Mangrum & Otter, 827 Mission St., San Francisco.

Montague Range and Furnace Co., 826 Mission St., San Francisco.

FURNITURE—BUILT-IN

Honsier Kitchen Cabinet Store, Pacific Bldg., San Francisco.

FURNITURE—SCHOOL, CHURCH, OFFICE, HOUSE, ETC.

Home Manufacturing Company, 543 Brannan St., San Francisco.

C. F. Weber & Co., 985 Market St., San Francisco.

Rucker-Fuller Desk Co., 677 Mission St., San Francisco.

F. W. Wentworth & Co., 539 Market St., San Francisco.

W. & J. Sloane, 216-228 Sutter St., San Francisco.

GARAGE HARDWARE

The Stanley Works, New Britain, Conn., represented in San Francisco, Los Angeles, Seattle by John T. Rowntree, Inc.

Richards-Wilcox Mfg. Co., Aurora, Ill., and Underwood Bldg., San Francisco.

ROBERTSON PROCESS METAL FOR ROOFING AND SIDING

HH ROBERTSON CO
BUILDING PRODUCTS BUILDING PRODUCTS

FORMERLY ASBESTOS PROTECTED METAL COMPANY

Hobart Building, San Francisco

Phone Garfield 522

HOT WATER ELECTRICALLY

ALL YOU WANT ALL THE TIME THERM-ELECT WATER HEATER for APARTMENT HOUSES, RESIDENCES, ETC.

ELECTRIC SALES SERVICE COMPANY

2532 Sixth Street, BERKELEY

Phone Berkeley 3070

ARCHITECTS' SPECIFICATION INDEX—Continued

- GARBAGE CHUTES AND INCINERATORS**
Kerner Incinerator Co., 77 O'Farrell St., San Francisco.
California Hydraulic Engineering & Supply Co., 70-72 Fremont St., San Francisco.
- GAS STEAM RADIATORS—FUMELESS, ETC.**
Clow Gas Steam Radiators, F. A. Hamilton, Agent, 101 Rialto Bldg., San Francisco.
- GAS STEAM RADIATORS, ETC.—Continued.**
Ra-Do Fumeless Gas Radiators, manufactured and sold by Baird-Bailhache Co., 478 Sutter St., San Francisco.
- GLASS**
American Window Glass Co., represented by L. H. Butcher Co., 862 Mission st., San Francisco.
Cobbleck-Kibbe Glass Co., 175 Jessie St., San Francisco.
Fuller & Goepf, 32 Page St., San Francisco.
W. P. Fuller & Company, all principal Coast cities.
- GRADING, WRECKING, ETC.**
Dolan Wrecking & Construction Co., 1607 Market St., San Francisco.
- GRANITE**
California Granite Co., Gen. Contractors' Ass'n, San Francisco.
Raymond Granite Co., Potrero Ave. and Division St., San Francisco.
- GRAVEL AND SAND**
Coast Rock & Gravel Co., Call-Post Bldg., San Francisco.
Del Monte White Sand, sold by Del Monte Properties Co., Crocker Bldg., San Francisco.
- GYMNASIUM EQUIPMENT**
Ellery Arms Co., 583 Market St., San Francisco.
A. G. Spalding & Bros., 625 Market St., San Francisco.
- HARDWALL PLASTER**
Henry Cowell Lime & Cement Co., San Francisco.
- HARDWARE**
Joost Bros., agents for Russell & Erwin hardware, 1053 Market St., San Francisco.
The Stanley Works, New Britain, Conn.; Coast sales offices, San Francisco, Los Angeles, and Seattle, Wash.
Corbin hardware, sold by Palace Hardware Co., 581 Market St., San Francisco.
Richards-Wilcox Mfg. Co., Aurora, Ill., Ewing-Lewis Co., 626 Underwood Bldg., San Francisco.
- HARDWOOD LUMBER—FLOORING, ETC.**
Dieckmann Hardwood Company, Beach and Taylor Sts., San Francisco.
H. N. McNab, 2307 17th Ave., Oakland.
Parrott & Co., 320 California St., San Francisco.
White Bros., cor. Fifth and Brannan Sts., San Francisco.
Strable Hardwood Company, First street, near Broadway, Oakland.
- HEATERS—AUTOMATIC, GAS, ELECTRIC**
Electric Sales Service Co., mfrs. of Therm-elect Water Heater, West Berkeley.
- "Jumphrey Radiantfire," The General Gas Light Co., 768 Mission St., San Francisco.
Pittsburg Water Heater Co., 478 Sutter St., San Francisco.
George H. Tay Company, Mission and Second Sts., San Francisco; 10th and Harrison Sts., Oakland.
Ra-Do Fumeless Gas Heater, sold by Baird-Bailhache Company, 478 Sutter St., San Francisco.
- HEATING AND VENTILATING CONTRACTOR'S, EQUIPMENT, ETC.**
Alex Coleman, 706 Ellis St., San Francisco.
C. A. Dunham Co., Sheldon Building, San Francisco.
Gilley-Schmid Company, 198 Otis St., San Francisco.
Hateley & Hateley, Mitau Bldg., Sacramento.
Knittle-Cashel Co., Inc., 1820 Ellis St., San Francisco.
General Boilers Co., 332 Monadnock Bldg., San Francisco.
Mangrum & Otter, 827-831 Mission St., San Francisco.
Moline Heat, Hobart Bldg., San Francisco.
James & Drucker, 450 Hayes St., San Francisco.
James A. Nelson, 517 Sixth St., San Francisco.
Ideal Heating & Engineering Co., 192 Erie St., San Francisco.
Illinois Engineering Co., 563 Pacific Bldg., San Francisco.
William F. Wilson Co., 328 Mason St., San Francisco.
Pacific Fire Extinguisher Co., 424 Howard St., San Francisco.
Scott Company, 243 Minna St., San Francisco.
Mechanical Engineering & Supply Co., 908 7th St., Sacramento.
George H. Tay Company, Mission and Second Sts., San Francisco; 10th and Harrison Sts., Oakland.
O. M. Simmons Co., 115 Mission St., San Francisco.
- HOLLOW TILE BLOCKS**
Cannon & Co., plant at Sacramento; office in Chronicle Bldg., San Francisco.
Gladding, McBean & Co., San Francisco, Los Angeles, Oakland and Sacramento.
Los Angeles Pressed Brick Co., Frost Bldg., Los Angeles.
- HOSPITAL FIXTURES**
Mott Company of California, 553 Mission St., San Francisco.
George H. Tay Company, Mission and Second Sts., San Francisco; 10th and Harrison Sts., Oakland.
- HOSPITAL SIGNAL SYSTEM**
Chicago Signal Co., represented by Garnett Young & Co., 612 Howard St., San Francisco.
- HOTELS**
St. Francis Hotel, Powell, Geary and Post Sts., San Francisco.

"The Perfect Automatic Valve"

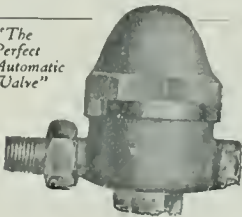

Haines Heating Systems

ASSURE

Heating Satisfaction

O. M. SIMMONS CO.

115 Mission St., San Francisco
Phone: Douglas 5497

CLARENCE E. MUSTO, Pres.

JOSEPH B. KEENAN, Vice-Pres.

GUIDO J. MUSTO, Sec'y & Treas.

JOSEPH MUSTO SONS=KEENAN CO.Phone Franklin
—6365—**MARBLE**OFFICE AND MILLS:
535-565 North Point St.,
SAN FRANCISCO, CAL.**ARCHITECTS' SPECIFICATION INDEX—Continued****INGOT IRON**

"Armco" brand, manufactured by American Rolling Mill Company, Middletown, Ohio, and 10th and Bryant streets, San Francisco.

INSPECTIONS AND TESTS

Robert W. Hunt & Co., 251 Kearny St., San Francisco.

INSULATION

American Insulex Company, Berkeley Bank building, Berkeley.

INCINERATORS

Kerner Incinerator Co., 77 O'Farrell St., San Francisco.

INTERIOR DECORATORS

Atherly Bros., 2032 Polk St., San Francisco.

Beach-Robinson Co., 239 Geary St., San Francisco.

Martin & Frederick, 1374 Sutter St., San Francisco.

John Breuner Co., 281 Geary St., San Francisco.
Sonnenschein Bros., 470 Sutter St., San Francisco.The Tormey Co., 1042 Larkin St., San Francisco.
Taylor Galleries, 1818 Harrison street, Oakland and San Francisco.

Freeman Art Shop, 386 Sutter St., San Francisco.

W. & J. Sloane, 216 Sutter St., San Francisco.

KITCHEN CABINETS

Hoosier Kitchen Cabinet Store (O. K. Brown, Mgr.), Pacific Bldg., San Francisco.

LAMP POSTS, ELECTROLIERS, ETC.

J. L. Mott Iron Works, 553 Mission St., San Francisco.

LANDSCAPE GARDENERS

MacRorie-McLaren Co., 141 Powell St., San Francisco.

LATHING AND PLASTERING

MacGruer & Simpson, Call-Post Bldg., San Francisco.

A. Knowles, Call-Post Bldg., San Francisco.

Jas. F. Smith, 273 Minna St., San Francisco.

LATHING MATERIAL

Pacific Materials Co., 525 Market St., San Francisco.

Truscoon Steel Co., Tenth St., near Bryant, San Francisco.

LIGHT, HEAT AND POWER

Great Western Power Company, Stockton St., near Sutter, San Francisco.

LIGHTING FIXTURES

Roberts Mfg. Co., 663 Mission St., San Francisco.

Perfeelite Manufacturing Co., Seattle, Wash.; San Francisco Representatives, Myers & Schwartz, 75 New Montgomery street, San Francisco;

1119 S. Los Angeles street, Los Angeles.

LIME

Henry Cowell Lime & Cement Co., 2 Market St., San Francisco.

LINOLEUM

D. N. & E. Walter & Co., 562 Mission St., San Francisco.

The Paraffine Companies, factory in Oakland; office, 34 First St., near Market, San Francisco.

W. & J. Sloane, 216-228 Sutter St., San Francisco.

LUBRICATING OIL STORAGE TANKS AND PUMPS

S. F. Bowser & Co., Inc., 612 Howard St., San Francisco

LUMBER

California Redwood Association, 216 Pine St., San Francisco.

Dudfield Lumber Co., Palo Alto, Cal.

Hart-Wood Lumber Co., Fifth and Berry Sts., San Francisco.

Pacific Manufacturing Company, San Francisco, Oakland and Santa Clara.

Pope & Talbot, foot of Third St., San Francisco.

Santa Fe Lumber Co., 16 California street, San Francisco.

Sunset Lumber Company, First and Oak Sts., Oakland.

MAIL CHUTES

American Mailing Device Corp., represented on Pacific Coast by Waterhouse-Wilcox Co., 523 Market St., San Francisco.

MANTELS

Mangrum & Otter, 827-831 Mission St., San Francisco.

California Brick Company, 604 Mission street, San Francisco.

MANUAL TRAINING EQUIPMENT

Richards-Wilcox Mfg. Co., Ewing-Lewis Co., 626 Underwood Bldg., San Francisco.

Smith-Booth-Usher Co., San Francisco and Los Angeles.

MARBLE

American Marble and Mosaic Co., 25 Columbus Square, San Francisco.

Joseph Musto Sons, Keenan Co., 535 N. Point St., San Francisco.

Vermont Marble Co., Coast branches, San Francisco, Portland and Tacoma.

METAL DOORS AND WINDOWS

Fire Protection Products Co., 3117 20th St., San Francisco.

Waterhouse-Wilcox Co., Inc., 523 Market St., San Francisco.

U. S. Metal Products Co., 330 Tenth St., San Francisco.

METAL FURNITURE

Forderer Cornice Works, 269 Potrero avenue, San Francisco.

MILL WORK

Dudfield Lumber Co., Palo Alto, Cal.

Pacific Manufacturing Company, San Francisco, Oakland and Santa Clara.

National Mill and Lumber Co., San Francisco and Oakland.

The Fink & Schindler Co., 218 13th St., San Francisco.

Frank Portman, 1619-20 Mission St., San Francisco.

Lannom Bros. Mfg. Co., 5th and Magnolia sts., Oakland.

MOTORS AND FANS

R. J. Davis, Dist. Sales Agent Century Motors and Fans, 171 Second St., San Francisco.

KNITTLE-CASHEL CO., Inc.**HEATING CONTRACTORS**

STEAM HEATING

HOT WATER HEATING

VENTILATING

POWER PLANTS

GENERAL PIPE WORK

REPAIRING

1820-22 Ellis Street, San Francisco

Phone West 964

ARCHITECTS' SPECIFICATION INDEX—Continued

OIL BURNERS

- Bunting Iron Works, 1215 First Nat. Bank bldg., San Francisco.
 Fess System Co., 220 Natoma St., San Francisco.
 S. T. Johnson Co., 1337 Mission St., San Francisco.
 T. P. Jarvis Manufacturing Co., 275 Connecticut St., San Francisco.
 G. E. Witt Co., 862 Howard St., San Francisco.

OIL STORAGE AND DISTRIBUTING STATIONS

- S. F. Bowser & Co., Inc., 612 Howard St., San Francisco.
 S. T. Johnson Co., 1337 Mission St., San Francisco.
 Wayne Oil Tank & Pump Co., 631 Howard St., San Francisco; 830 S. Los Angeles St., Los Angeles.

OFFICE EQUIPMENT

- C. F. Weber Co., 985 Market St., San Francisco.
 Rucker-Fuller Co., 677 Mission St., San Francisco.
 F. W. Wentworth & Co., 539 Market St., San Francisco.

ORNAMENTAL IRON AND BRONZE.

- California Artistic Metal and Wire Co., 349 Seventh St., San Francisco.
 Palm Iron & Bridge Works, Sacramento.
 C. J. Hillard Company, Inc., 19th and Minnesota Sts., San Francisco.
 Schrader Iron Works, Inc., 1247 Harrison St., San Francisco.

OVERHEAD CARRYING SYSTEMS

- California Hydraulic Engineering & Supply Co., 70-72 Fremont St., San Francisco.
 Richards-Wilcox Mfg. Co., Aurora, Ill., and Underwood Bldg., San Francisco.

PAINT FOR STEEL STRUCTURES, BRIDGES, ETC.

- The Paraffine Companies, Inc., 34 First St., San Francisco.
 Premier Graphite Paint and Pioneer Brand Red Lead, made by W. P. Fuller & Co., San Francisco.
 Hill, Hubbell & Company, No. 1 Drumm St., San Francisco.
 Wadsworth, Howland Co., makers of Bay State Brick and Cement Coating, Boston, Mass.
 Hambley & Son, Distributors in San Francisco and Los Angeles.

PAINTING, TINTING, ETC.

- Atherly Bros., 2032 Polk St., San Francisco.
 J. F. Wayne Co., 1914 Fillmore St., San Francisco.
 I. K. Kissel, 1747 Sacramento St., San Francisco.
 D. Zelinsky & Sons, San Francisco and Los Angeles.
 The Tormey Co., 681 Geary St., San Francisco.
 Fick Bros., 475 Haight St., San Francisco.
 Pacific Painting and Roofing Co., Pacific building, San Francisco; and 388 12th street Oakland.
 PAINTS, OILS, ETC.
 California Paint Company (see advertisement above).
 Magner Bros., 414-424 Ninth St., San Francisco.
 Bass-Hueter Paint Co., Mission, near Fourth St., San Francisco and all principal coast cities.
 R. N. Nason & Company, San Francisco, Los Angeles, Portland and Seattle.
 Ronfle Company, Pacific building, San Francisco; and 388 12th street, Oakland.
 W. P. Fuller & Co., all principal Coast cities.
 "Satinette," Standard Varnish Works, 55 Stevenson St., San Francisco.
 Palace Hardware Co., 581 Market St., San Francisco.

PANELS AND VENEER

- White Bros., Fifth and Brannan Sts., San Francisco.

PARTITIONS—FOLDING AND ROLLING

- J. G. Wilson Corporation, 600 Metropolitan Bldg., Los Angeles; Waterhouse-Wilcox Co., Underwood Bldg., San Francisco.

PENCILS

- Eberhard Faber, Monadnock Bldg., San Francisco.

PIPE—STEEL AND WROUGHT IRON

- Western Pipe & Steel Co., 444 Market St., San Francisco; 1788 N. Broadway, Los Angeles.
 George H. Tay Company, Mission and Second Sts., San Francisco; 10th and Harrison Sts., Oakland.

PLAYGROUND APPARATUS

- A. G. Spalding & Bros., 625 Market St., San Francisco.

PLUMBING CONTRACTORS

- Alex Coleman, 706 Ellis St., San Francisco.
 Gilley-Schmid Company, 198 Otis street, San Francisco.
 Hateley & Hateley, Mitau Bldg., Sacramento.
 Scott Co., Inc., 243 Minna St., San Francisco.
 Wm. F. Wilson Co., 328 Mason St., San Francisco.

PLUMBING FIXTURES, MATERIALS, ETC.

- All-In-One Company, Ochsner bldg., Sacramento.
 California Steam & Plumbing Supply Co., 671 Fifth St., San Francisco.
 Crane Co., San Francisco, Oakland, Los Angeles.
 Gilley-Schmid Company, 198 Otis St., San Francisco.
 Haines, Jones & Cadbury Co., 857 Folsom St., San Francisco.
 H. Mueller Manufacturing Company, 635 Mission St., San Francisco.
 Holbrook, Merrill & Stetson, 64 Sutter St., San Francisco.
 J. L. Mott Iron Works, D. H. Gulick, selling agent, 553 Mission St., San Francisco.
 National Valve Company, 23-25 Minna St., San Francisco.
 Pacific Sanitary Manufacturing Co., 67 New Montgomery St., San Francisco.
 George H. Tay Company, Mission and Second Sts., San Francisco, 10th and Harrison Sts., Oakland.
 Standard Metals Mfg. Co., 1300 N. Main st., Los Angeles.
 West Coast Porcelain Manufacturers, Rialto building, San Francisco.
 Wm. F. Wilson Co., 328 Mason St., San Francisco.

POLES AND PILING

- Sante Fe Lumber Co., 16 California street, San Francisco.

POWER PLANTS

- Knittle-Cashel Co., Inc., 1820 Ellis St., San Francisco.

POWER TRANSMITTING MACHINERY

- Meese & Gottfried, San Francisco, Los Angeles, Portland, Ore., and Seattle, Wash.

PUMPS

- Chicago Pump Co., represented by Garnett, Young & Co., 612 Howard St., San Francisco.
 California Hydraulic Engineering & Supply Co., 70 Fremont St., San Francisco.
 Simonds Machinery Co., 117 New Montgomery St., San Francisco.
 Ocean Shore Iron Works, 558 Eighth St., San Francisco.
 Pacific Pump & Supply Company, 851-853 Folsom St., San Francisco.
 George H. Tay Company, Mission and Second Sts., San Francisco; 10th and Harrison Sts., Oakland.

PUMPS—HAND OR POWER, FOR OIL AND GASOLINE

- S. F. Bowser & Co., Inc., 612 Howard St., San Francisco.
 S. T. Johnson Co., 1337 Mission St., San Francisco.
 Wayne Oil Tank & Pump Co., 631 Howard St., San Francisco; 830 S. Los Angeles St., Los Angeles.
 George H. Tay Company, Mission and Second Sts., San Francisco; 10th and Harrison Sts., Oakland.



Yards:
Tracy - Brentwood
Patterson - Newman
California

Phones:
Kearny 2073 - 2074

SANTA FE LUMBER CO.

A. J. RUSSELL, Mgr.

Wholesale and Retail

LUMBER

POLES AND PILING
OIL RIG AND SHIP TIMBERS
SAGINAW SPECIAL SHINGLES

FENCE POSTS
SIMPLEX SILOS
PAPEC ENSILAGE CUTTERS

16 California Street

San Francisco, Calif.

from tree to Consumer

Pine and Redwood Lumber

SASH DOORS AND MILL WORK

SUNSET LUMBER COMPANY

MANUFACTURERS — WHOLESALE AND RETAIL

Main Office and Yards:

FIRST AND OAK STREETS, OAKLAND

Phone Oakland 1820

POPE & TALBOT

Manufacturers, Exporters and Dealers in

Lumber, Timber, Piles, Spars, etc.

Office, Yards and Planing Mills

859-869 THIRD ST., SAN FRANCISCO, CAL.

Mills, Port Gamble, Port Ludlow and Utsalady, Washington

PACIFIC MANUFACTURING COMPANY

MILLWORK, SASH AND DOORS

Hardwood Interior Trim a Specialty

Main Office:

SANTA CLARA, CALIF.

SAN FRANCISCO, 177 Stevenson Street
OAKLAND, 1001 Franklin Street

LOS ANGELES, 908 Washington Building
SAN JOSE, 16 North First Street

ARCHITECTS' SPECIFICATION INDEX—Continued

RADIATOR TRAPS

C. A. Dunham Co., Sheldon Bldg., San Francisco.

REINFORCING STEEL

Edward L. Soule, Rialto Building, San Francisco.
Gunn, Carle & Co., Inc., 444 Market street, San Francisco.

Pacific Coast Steel Co., Rialto Building, San Francisco.

Trancon Steel Co., 527 10th St., San Francisco.

REFRIGERATORS

McCray Refrigerator Company, San Francisco office, 765 Mission street.

REVERSIBLE WINDOWS

Hauser Window Company, 157 Minna St., San Francisco.

ROOFING CONTRACTORS

Bender Roofing Company, Monadnock Bldg., San Francisco.

National Roofing Company, Pacific Roofing Co., C. G. Williams, A. K. Goodmundson, 2140 San Pablo ave., Oakland.

ROOFING AND ROOFING MATERIALS

"Malthoid" and "Ruberoid," manufactured by Paraffine Companies, Inc., San Francisco.

United Materials Co., Crossley Bldg., San Francisco.

H. H. Robertson Co., Hobart Bldg., San Francisco.

RUBBER TILING

New York Belting and Packing Company, 518 Mission St., San Francisco.

SAFETY TREADS

Pacific Materials Co., 525 Market St., San Francisco.

SAND

Del Monte White Sand, Del Monte Properties Co., 401 Crocker Bldg., San Francisco.

SASH CORD

Samson Spot Sash Cord, John T. Rowntree, Pacific Coast Agent, San Francisco and Los Angeles.

SCENIC PAINTING—DROP CURTAINS, ETC.

The Edwin H. Flagg Scenic Co., 1638 Long Beach Ave., Los Angeles.

SCHOOL FURNITURE AND SUPPLIES

C. F. Weber & Co., 985 Market St., San Francisco; 512 S. Broadway, Los Angeles.

Rucker-Fuller Desk Company, 677 Mission St., San Francisco.

SHEATHING AND SOUND DEADENING

Samuel Cabot Mfg. Co., Boston, Mass., agencies in San Francisco, Oakland, Los Angeles, Portland, Tacoma and Spokane.

The Paraffine Companies, Inc., 34 First St., San Francisco.

SHEET METAL WORK

Forderer Cornice Works, 269 Potrero ave., San Francisco.

U. S. Metal Products Co., 330 10th street, San Francisco.

Fire Protection Products Co., 3117 20th street, San Francisco.

SHINGLE STAINS

Bass-Inneter Paint Company, all principal Coast cities.

Cabot's Creosote Stains, sold by Pacific Building Materials Co., 525 Market St., San Francisco.

Fuller's Pioneer Shingle Stains, made by W. P. Fuller & Co., San Francisco.

Argonaut Shingle Stains. The Glidden Co., 123 Hooper St., San Francisco.

SHINGLES—STONE

McClenahan Products Co., Inc., 670 Howard St., San Francisco.

SINKS—COMPOSITION

Petrium Sanitary Sink Co., Fifth and Page Sts., Berkeley.

STATIONERY AND SUPPLIES

Schwabacher-Frey Stationery Co., 609 Market St., San Francisco.

H. S. Crocker Co., 565 Market street, San Francisco.

STEEL HEATING BOILERS

California Hydraulic Engineering & Supply Co., 70-72 Fremont St., San Francisco.

General Boilers Co., 332 Monadnock Bldg., San Francisco.

STEEL TANKS, PIPE, ETC.

Ocean Shore Iron Works, 558 Eighth St., San Francisco.

S. T. Johnson Co., 1337 Mission St., San Francisco.

STEEL AND IRON—STRUCTURAL

Central Iron Works, 621 Florida St., San Francisco.

Mortenson Construction Co., 19th and Indiana Sts., San Francisco.

Pacific Rolling Mills, 17th and Mississippi Sts., San Francisco.

Palm Iron & Bridge Works, Sacramento.

U. S. Steel Products Co., Rialto Bldg., San Francisco.

Schrader Iron Works, Inc., 1247 Harrison St., San Francisco.

Western Iron Works, 141 Beale St., San Francisco.

STEEL PRESERVATIVES

Hill, Hubbell & Company, No. 1 Drumm St., San Francisco.

STEEL ROLLING DOORS

Pacific Building Materials Co., Underwood Bldg., San Francisco.

J. G. Wilson Corporation, 600 Metropolitan Bldg., Los Angeles.

STEEL SASH

Bayley-Springfield solid steel sash, sold by Pacific Materials Co., 525 Market St., San Francisco.

"Fenestra," solid steel sash, manufactured by Detroit Steel Products Company, Detroit, Mich. Direct factory sales office, Foxcroft Bldg., San Francisco.

U. S. Metal Products Company, 330 Tenth St., San Francisco.

Truscon Steel Company, 527 Tenth street, San Francisco.

STORE FRONTS

The Kawneer Manufacturing Company, West Berkeley, California.

Zouri Safety Sash Bars—Cobbledick-Kibbe Glass Company, 175 Jessie St., San Francisco.

STUDDING—FIREPROOF STEEL

Steel Studding Company, 1216 Folsom St., San Francisco.

SUMP AND BILGE PUMPS

California Hydraulic Engineering & Supply Co., 70-72 Fremont St., San Francisco.

MOLINE HEAT

Hobart Building

San Francisco

TELEPHONE SUTTER 3818

ARCHITECTS' SPECIFICATION INDEX—Continued

SWITCHES

Wemco Safety Switch, manufactured and sold by W. E. Mushet Co., 502 Mission St., San Francisco.

Western Electric Safety Switch Co., Inc., 247 Minna street, San Francisco.

THEATER AND OPERA CHAIRS

C. F. Weber & Co., 365 Market street, San Francisco.

Rucker-Fuller Desk Co., 677 Mission street, San Francisco.

THERMOSTATS FOR HEAT REGULATION

Johnson Service, Rialto Bldg., San Francisco.

TILES, MOSAICS, MANTELS, ETC.

Mangrum & Otter, 827-831 Mission street, San Francisco.

TILE FOR ROOFS

Cannon & Co., Sacramento; and 77 O'Farrell St., San Francisco.

Gladding, McBean & Co., Crocker Bldg., San Francisco.

United Materials Co., Sharon Bldg., San Francisco.

TRANSMISSION MACHINERY

Meese & Gottfried Co., San Francisco, Los Angeles and Portland.

VACUUM CLEANERS

United Electric Company, Canton, Ohio, manufacturers of Tucc Cleaners, sold in California by San Francisco Compressed Air Cleaning Co., Stockton and Sutter Sts., San Francisco

VALVES—PIPES AND FITTINGS

California Steam & Plumbing Supply Co., 671 Fifth St., San Francisco.

Crane Radiator Valves, manufactured by Crane Co., Second and Brannan Sts., San Francisco.

National Valve Company, 23-25 Minna St., San Francisco.

Grinnell Co., 453 Mission St., San Francisco.

O. M. Simmons Co., 115 Mission St., San Francisco.

H. Mueller Mfg. Co., 635 Mission street, San Francisco.

W. E. Mushet Co., 502 Mission St., San Francisco

George H. Tay Company, Mission and Second streets, San Francisco; 10th and Harrison streets, Oakland.

Shroeder Direct Flush Valves, mfrd. by Standard Metals Mfg. Co., 1300 N. Main street, Los Angeles.

VALVE PACKING

N. H. Cook Belting Co., 317 Howard St., San Francisco.

Everlasting Blow-off Valves. General Machinery and Supply Co., 39 Stevenson street, San Francisco.

VARNISHES

Bass-Hueter Paint Company, Mission, near 4th street, San Francisco, and all principal coast cities.

California Paint Company, 1797 Twelfth St., Oakland.

W. P. Fuller Co., all principal Coast cities.

R. N. Nason & Co., San Francisco, Los Angeles, Portland and Seattle.

Standard Varnish Works, 55 Stevenson St., San Francisco.

VENETIAN BLINDS, AWNINGS, ETC.

C. F. Weber & Co., 985 Market St., San Francisco.

Western Blind & Screen Co., 2702 Long Beach Ave., Los Angeles.

VITREOUS CHINAWARE

Pacific Porcelain Ware Company, 67 New Montgomery St., San Francisco.

West Coast Porcelain Manufacturers, Rialto Building, San Francisco.

WALL BEDS, SEATS, ETC.

Marshall & Stearns Co., 1154 Phelan Bldg., San Francisco.

WALL BOARD

"Amiwd" Wall Board, manufactured by The Paraffine Companies, Inc., 34 First St., San Francisco.

WALL PAINT

Nason's Opaque Flat Finish, manufactured by R. N. Nason & Co., San Francisco, Portland and Los Angeles.

San-A-Cote and Vel-va-Cote, manufactured by the Brininstool Co., Los Angeles.

WALL PAPER AND DRAPERIES

Arthur Brown, Foxcroft Bldg., San Francisco.

Beach-Robinson Co., 239 Geary St., San Francisco.

The Tormey Co., 681 Geary St., San Francisco. W. & J. Sloane, 216-228 Sutter St., San Francisco.

Uhl Bros., San Francisco.

WATERPROOFING FOR CONCRETE, BRICK, ETC.

Armorite Damp Resisting Paint, made by W. P. Fuller & Co., San Francisco.

Bay State Brick & Cement Coating, manufactured by Wadsworth, Howland Co., Boston; Hambley & Son., Distributors for Northern and Southern California.

Gunn, Carle & Co., Inc., "Hydrate," 444 Market street, San Francisco.

Imperial Waterproofing, manfrd. by Brooks & Doerr, Reed Baxter, agent, Merchants National Bank Bldg., San Francisco.

Pacific Materials Co., 525 Market St., San Francisco.

Samuel Cabot Mfg. Co., Boston, Mass., agencies in San Francisco, Oakland, Los Angeles, Portland, Tacoma and Spokane.

WATER SUPPLY SYSTEMS

Kewanee Water Supply System—Simonds Machinery Co., agents, 117 New Montgomery St., San Francisco.

Pacific Pump & Supply Company, 851-853 Folsom St., San Francisco.

Smith-Booth-Usher Co., San Francisco and Los Angeles.

Baird-Bailhache Co., 478 Sutter street, San Francisco.

WHEELBARROWS—STEEL

Western Iron Works, Beale and Main Sts., San Francisco.

WHITE ENAMEL

"Gold Seal," manufactured and sold by Bass-Hueter Paint Co. All principal Coast cities. "Silkenwhite," made by W. P. Fuller & Co., San Francisco.

"Satinette," Standard Varnish Works, 55 Stevenson St., San Francisco.

WINDOW SHADES

W. & J. Sloane, 216-228 Sutter St., San Francisco.

WINDOW SASH CORD

Sampson Spot Cord, John T. Rowntree, Pacific Coast agents, San Francisco and Los Angeles.

WINDOWS, REVERSIBLE, CASEMENT, ETC.

Hauser Window Co., 157 Minna St., San Francisco.

The Kawneer Company, West Berkeley, California. (Simplex Fixtures.)

J. G. Wilson Corporation, 600 Metropolitan Bldg., Los Angeles; Waterhouse-Wilcox Co., Underwood Bldg., San Francisco.

WIRE FENCE

Standard Fence Co., 245 Market street, San Francisco; and 310 12th street, Oakland.

WOOD MANTELS

Fink & Schindler, 218 13th St., San Francisco. Mangrum & Otter, 827 Mission St., San Francisco.

W. E. JOHNSTON

V. A. ANDERSON

Life Insurance Engineers

Submit your INSURANCE PROBLEMS to us.

210 Crocker Building, San Francisco

Phone Kearny 4048

MOTT PLUMBING FIXTURES

Architects and their clients are invited to visit our Showrooms, 553-555 Mission Street, San Francisco; D. H. Gulick, Sales Agent. Los Angeles Office, 1001 Central Building; J. R. Mayhew, Sales Agent.

Mott Company of California

MUELLER -- BRASS GOODS

Recognized as the Standard of excellence in plumbing. It pays to use them, and other **Mueller** Brass Goods. *The first cost is practically their last cost.*

H. Mueller Mfg. Co.

635 MISSION STREET, SAN FRANCISCO, CAL.

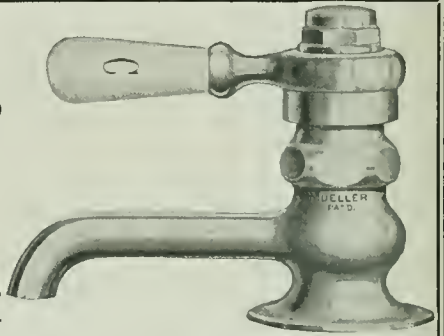

STORM KING and AMERICAN WARM AIR FURNACES

FURNACE FITTINGS AND REPAIRS

Montague Range & Furnace Company

327-329 JESSIE STREET

Phone Garfield 1422

826-830 MISSION STREET

SAN FRANCISCO, CALIF.

DON'T NEGLECT YOUR HEATING SYSTEM.
THE BEST IS NONE TOO GOOD!

All kinds of Galvanized Iron Work — Furnaces, Pipes, Ventilators — Sheet Metal for Planing Mills, Fruit Dryers, Rice Mills. Kitchen Equipment, including Steam Tables, Sinks, Canopies, Urn Stands, Etc.

JAMES A. NELSON

Heating and Ventilating Contractor

Phone, Garfield 1959

517-519 SIXTH ST., SAN FRANCISCO

OAK FLOORS

(For Everlasting Economy)



American Oak For American Homes

Mr. Architect, insure the continued satisfaction of your clients by specifying American Oak Flooring. A thorough investigation will convince any fair-minded professional man that it is superior in finish, grade and durability to any other.

The purchase of inferior Oak Flooring at low prices is a false economy against which you want to protect your clients.

Domestic vs. Foreign Oak

The low quality Japanese oak sold in this country is a poor substitute for the American. It not only lacks the grain or flower

which make American oak so beautiful, but it also lacks its strength.

It will be found to be very porous, breaking off evenly, which shows its brashy nature.

This trade-mark, stamped on every stick, is always a guarantee to you and to your clients of American-grown Oak Flooring of the highest quality.

This Association maintains its own inspection over every phase of air seasoning, kiln drying, milling and grading.

Insist upon its trade-mark when specifying Oak Floors.



Upon request we will mail hooklets outlining our educational and other work for Oak Floors, which you will find interesting and valuable in the practice of your profession.

OAK FLOORING MFRS. ASSN.
1036 Ashland Block, Chicago, Ill.



See page 389, Sweet's Catalogue, for specifications of various grades.

IDEAL KITCHEN ARRANGEMENT

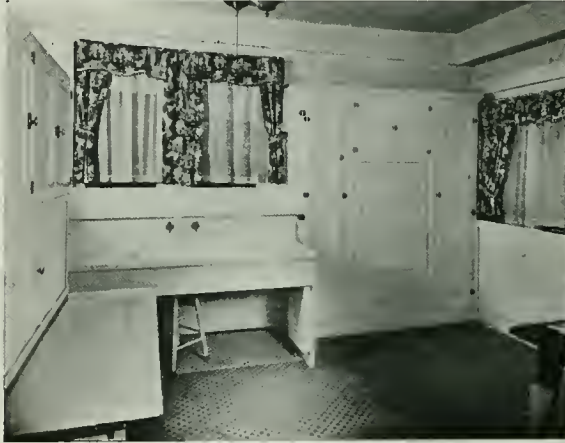

Saves **\$200.00**
 Saves **50%** space
 Saves steps

THE NEW

Peerless Breakfast Nook

Kitchen Cupboard, Cooler, Broom Closet and
 Ironing Board Combination.

You should investigate these facts and figures. See this and many other up-to-date space saving, labor saving, conveniences and get a blue-print of this Ideal Kitchen at

The
Hoosier Store

Pacific Building

Mezzanine Floor

4th and Market Streets

San Francisco

Sutter 4122



FOR HOMES OR APARTMENTS

The Petrium Sanitary Sink is shown in these pictures. Note its Beautiful Snow White Appearance.



DURABLE -- SANITARY -- NON-POROUS
NON-ABSORBENT DRAIN BOARDS

All One Piece -- No Cracks or Crevices -- Made Any Size

Petrium Sanitary Sink

COSTS ONE-HALF THE PRICE OF PORCELAIN SINK

on exhibition at



The
Hoosier Store

Pacific Building
Mezzanine Floor
4th and Market Streets
San Francisco
Sutter 4122

(Also at 77 O'FARRELL STREET)



Brininstool

San-a-Cote

(GLOSS—Can be Scrubbed)

AN INTERIOR WALL FINISH

For bath rooms, kitchens, hospitals, schools, office and public buildings. Ask dealers, owners, architects and contractors about this durable, sanitary, washable, economical wall covering. Brininstool makes a paint for every purpose, and every can purposely good.

THE BRININSTOOL CO., LOS ANGELES

COLOR GRINDERS AND PAINT MANUFACTURERS

Distributors—The Brininstool Co., 1174 Phelan Bldg., San Francisco, Cal.; The Brininstool Co., 222 Abington Bldg., Portland, Ore.; Schutz Paint Co., Fresno, Cal.; Schneider, Chappell & Jones, Sacramento, Cal.; Salt Lake Glass & Paint Co., Salt Lake City, Utah; Griffin Paint Co., Ogden, Utah; Campbell Hardware Co., First and Madison Sts., Seattle, Wash.; Imperial Valley Hardware Co., El Centro, Calexico, Imperial, Brawley, Seeley, Cal.; Spokane Hardware Co., Spokane, Wash.; Continental Paint Company, 328 South First St., San Jose, Cal.; Los Angeles Wallpaper & Paint Co., 525 So. Main St., Los Angeles, Cal.; H. A. Berger, 3338 13th St., San Diego, Cal.; H. L. Christian, Blythe, Cal.; Ezra Thayer, Phoenix, Ariz.; Miami Lumber & Supply Co., Miami, Ariz.

RELIANCE BALL BEARING DOOR HANGERS

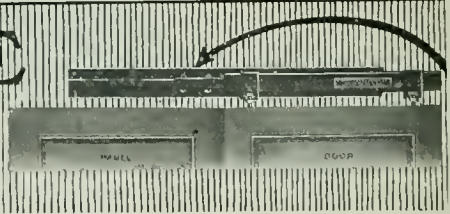

To get as near perfection as possible, use

RELIANCE "HANGERS" and "Reliance-Grant" Controllers

These insure fast service, practically noiseless and slamless doors.

Reliance-Grant Elevator Equipment Corp'n

PARK AVENUE AND 40TH STREET, NEW YORK

PACIFIC COAST AGENTS

Waterhouse-Wilcox Co.	San Francisco and Los Angeles, Cal.
Columbia Wire & Iron Works	Portland, Ore.
D. E. Fryer & Company	Seattle, Spokane, Tacoma, Wash. and Great Falls, Mont.

WE MAKE THE FOLLOWING

SCULPTURED BRONZE
ENTRANCE DOORS,
BRONZE MAUSOLEUM DOORS,
MONUMENTAL BRONZE WORK,
BANK COUNTERS,
MEMORIAL
TABLETS,
CREMATORY
URNS,
STATUES,
FIGURES
PORTRAITS

ECCLESIASTICAL METAL
WORK,
ELECTRIC LIGHT STANDARDS,
CAST BRONZE AND IRON
LANTERNS,
FOUNTAINS,
SUN-DIALS,
CHANDELIERS,
BULLETIN
BOARDS,
MANTELS,
VASES,

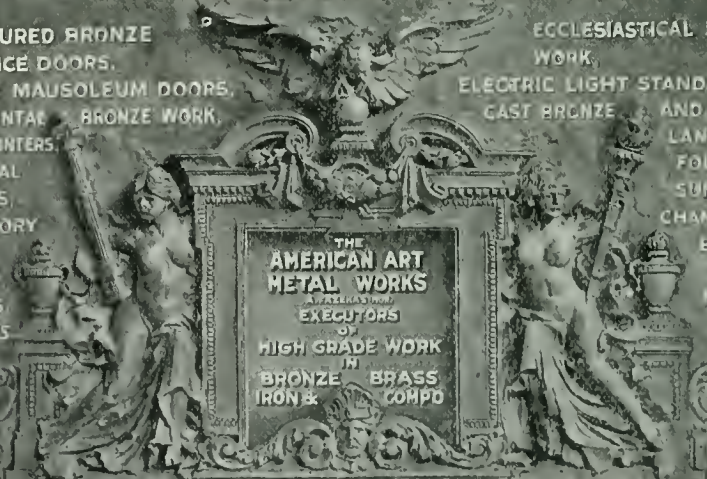

THE
AMERICAN ART
METAL WORKS
INTERNATIONAL
EXECUTORS
OF
HIGH GRADE WORK
IN
BRONZE BRASS
IRON & COPPER

13 GRACE ST

SAN FRANCISCO

PHONE MKY 30



Court House of Yolo County, Woodland, California *by* William H. Weeks, Architect

The Weal of The People

YOU recall the conclusion of the Roman Twelve Tables, "The Supreme law of all is the weal of the people." And centuries have not altered this statement.

WHEN an architect is commissioned to plan a public structure, his responsibilities are heavy. His edifices must fittingly represent the ideals of his clients, as well as serve as a criterion for the country at large. The manner in which these problems have been solved can best be ascertained in the above reproduction.

IN keeping with the character of a building of this type, it is pleasing to record that W. P. Fuller & Co. products were specified exclusively in the above structure.

W. P. FULLER & CO.

"Since '49"

Manufacturers



PAINTS

ENAMELS

VARNISHES

CANNON & CO.

Clay Products

Denison Interlocking Tile

Face Brick

Hollow Tile

Roof and Floor Tile

Factory and General Offices:
SACRAMENTO, CALIFORNIA

Highest Standard of Quality

Complete and Dependable Service

TROPICO POTTERIES, Inc.



Successors to
PACIFIC MINERALS AND CHEMICAL COMPANY
GLENDALE, CALIF.

ARCHITECTURAL TERRA COTTA

VITRIFIED CLAY SEWER PIPE
TERRA COTTA FLUE LINING
TERRA COTTA CHIMNEY PIPE

FAIENCE TILE
DRAIN TILE
WATER PIPE

GLADDING, McBEAN & CO.

MANUFACTURERS CLAY PRODUCTS
CROCKER BUILDING, SAN FRANCISCO
WORKS, LINCOLN, CAL.



The HUMPHREY
Radiantfire

If the Humphrey Radiantfire had no other quality to recommend it, the fact that it is absolutely odorless would be sufficient reason why you should substitute it for the mussy open fire. A perfect mixture burned in scientifically constructed burners, with nothing to interfere with the combustion. Produces radiant rays of heat that do not affect the air you breathe. A variety of designs provide harmonious equipment for rooms of various decorative treatment and affords selection to suit the taste of your clients.

Write for special architectural catalog.

The General Gas Light Company
New York Kalamazoo San Francisco



PIPE
 Valves & Fittings
 STEAM & WATER SUPPLIES
 Heating Material
PLUMBING GOODS
 Pumps

GEORGE H. TAY COMPANY
 SAN FRANCISCO OAKLAND
 MISSION & SECOND STS. TENTH & HARRISON STS.
 TELEPHONE DOUGLAS 2240 TELEPHONE LAKESIDE 4200

Ford

Whether for commercial purposes or pleasure, the Ford car will answer any requirement. It has proven its worth in every field of endeavor.

For eighteen years we have catered to the wants of the Ford buying public.

We can offer you the benefits of that long experience by giving you the acme of service through our coastwise organization.

William L. Hughson Co.

Since 1903

Geary at Van Ness, San Francisco
 Prospect 607



Seattle

Portland

Oakland

Los Angeles

San Diego

THE HOME of BYBAMOPA WARE

You are cordially invited to visit the

**FREEMAN
ART SHOP**

Where there is displayed only the unusual and exclusive things in Lamp Shades, Mirrors, Candle Sucks, Candles, Book Ends, Oriental Rugs, Pottery, Bronzes, Solid Mahogany Furniture, Oil Paintings, Pastels, Fine Prints, Greeting Cards, Picture Framing.

386 SUTTER STREET, at Stockton
Interior Decorators

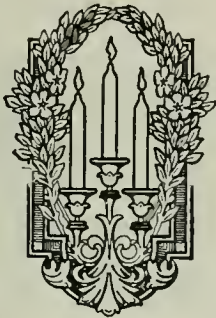

Beach-Robinson Co.

Decorators and Furnishers

Carpets

Draperies

Furniture

Rugs

Wall Paper

Ranson E. Beach

239 Geary Street, 3d Floor

Union Square

Phone, Sutter 580

San Francisco, Cal.



ADD CHEER and COMFORT

to the Home by having a

WELL DESIGNED INTERIOR

Before Completing Your Plans, CONSULT

SONNENSCHN BROS.

INTERIOR DECORATORS

Furniture and Draperies Made to Order

Factory

718 NATOMA ST., Phone Market 1145

Show and Salesroom

470 SUTTER ST., Phone Kearny 2051



AYLOR GALLERIES

Artistic Interiors

SPECIAL FURNITURE DRAPES - WALL PAPER

1818 Harrison St., near 19th, Oakland, Calif.

Phone Lakeside 3107

The GOLD MEDAL MAIL CHUTE



INSTALLED IN
THE NEW
SAN FRANCISCO
CITY HALL
AND THE
WHITE MARBLE
MERRITT
BUILDING,
LOS ANGELES

Given highest award at
Panama - Pacific International
Exposition, 1915.

Waterhouse-Wilcox Co.

California
Representatives

523 Market Street
SAN FRANCISCO

331 E. 4th Street.
LOS ANGELES

F. T. CROWE & CO.
Seattle, Wash.

THE J. McCracken Co.
Portland, Oregon

American Mailing
Device
Corporation

CLINTON WELDED WIRE FABRIC AND LATH

The Perfect Support for Stucco
and Interior Plaster. Complete
Stock for Immediate Delivery.
Steel Reinforcing Bars in Stock.

L. A. NORRIS CO.

140 Townsend Street

Phone Kearny 5375 San Francisco



McCRAY REFRIGERATORS FOR ALL PURPOSES

It is our particular desire to
impress the Architects of
America with the fact that
McCray builds refrigerators
for all purposes. Thousands
of fine residences, hotels,
clubs, restaurants, factory
cafeterias, hospitals, stores and
markets depend on McCray
for efficient, economical re-
frigerator service.

McCRAY REFRIGERATOR CO.
765 Mission Street, San Francisco, Calif.
Home Office and Factory
Kendallville, Ind

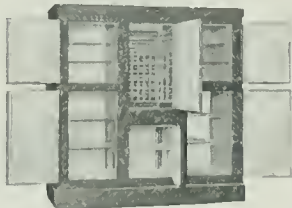

YOU KNOW that a building
should be watertight and
WE KNOW that it can be
made so with

IMPERIAL WATERPROOFING

LOOK FOR  THE LABEL

If your building is leaking through
the walls or around the windows, or
if the Basement walls are wet below
ground — call up SUTTER 978.

IMPERIAL WATERPROOFING
is manufactured by BROOKS &
DOERR, 460 7th St., San Francisco

WATEREX REED BAXTER
DISTRIBUTOR

1002-04 Merchants National Bank Building,
Phone Sutter 978
SAN FRANCISCO, CAL.
3419 Broadway, OAKLAND, CAL.

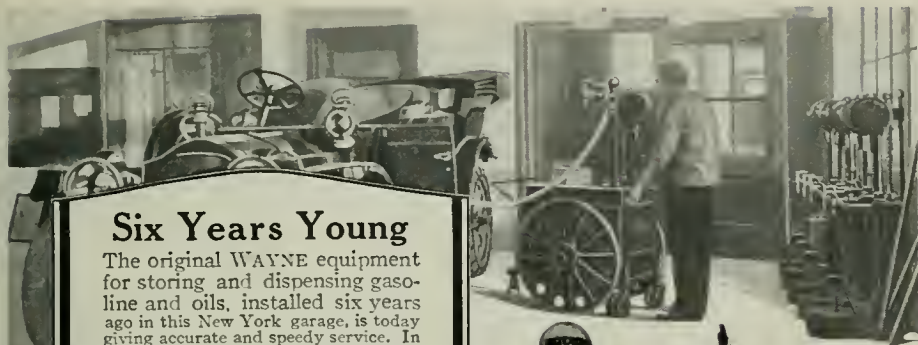

Six Years Young

The original WAYNE equipment for storing and dispensing gasoline and oils, installed six years ago in this New York garage, is today giving accurate and speedy service. In Wayne pumps the delicate adjustment essential for accuracy is combined with a durability that assures satisfaction for years and years.

There is a Wayne System for every need of the public garage. The service of Wayne engineers in advising and planning is yours without cost or obligation.

Wayne Oil Tank & Pump Co.
746 Canal St., Ft. Wayne, Ind.

San Francisco Office
631-633 Howard St.
Phone Garfield 1350

Los Angeles Office
830 S. Los Angeles St.
Phone Main 1600

Wayne
EST. U. S. 1892
TRADE MARK
Liquid Storage Systems



Cut
No. 230
For Gas
and Oil

Cut
No. 280
One-gallon
gasoline

Cut
No. 200
Lubricating
oils



DEL MONTE & FAN SHELL BEACH WHITE SAND

With our WASHING and DRYING PLANT in full operation, we can now ship promptly above SANDS fresh water washed, and steam dried, or direct from pits.

Del Monte Properties Company

Phone Sutter 6130 401 Crocker Building

San Francisco



Colusa Grammar School — William H. Weeks, Architect

Credit for this building was erroneously given to Mr. J. S. Gould. Acknowledgment is hereby made of error and duly credited to Mr. William H. Weeks.

All educated men are peers — Confucius

EVERY community has well defined marks of progress or retrogression. School buildings form an unswerving standard for comparison.

COLUSA has not alone established her right to be called progressive, but she has insured her future. The leaders of the Colusa of tomorrow are today mastering the three Rs (and more) in this splendidly-modern school.

ATTRACTIVE-exterior, inviting-interior, — this Colusa Grammar School is rendering an unmeasurable service to the community. No small part of the appeal of this splendid structure is due FULLER PRODUCTS, which were used exclusively upon this educational plant.

W. P. FULLER & CO.

"Since '49"

Manufacturers

PAINTS

ENAMELS

VARNISHES

San Francisco
Oakland
Sacramento
Stockton

Los Angeles
San Diego
Hollywood
Pasadena

Long Beach
Santa Monica
Portland
Tacoma

Seattle
Spokane
Boise
Salt Lake

The 2-part Trap

— individually tested

When the Testing Stand at the factory puts the O. K. on a trap, that trap is ready for business. Installed on a radiator, it will stop the steam and pass the air and water. It will keep on doing this for—well, we don't know for how many years.

Many of the original traps after seventeen years of continuous service are still operating satisfactorily and with promise of working indefinitely. Mechanically the Dunham Trap is better today than it ever was.

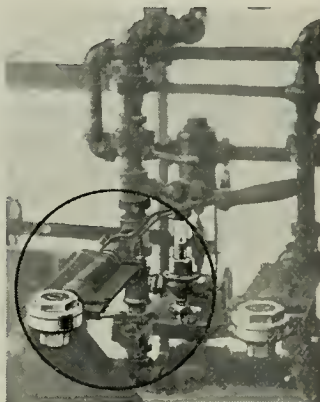

The DUNHAM
REG. TRADE-MARK
HEATING SERVICE

C. A. DUNHAM COMPANY

Los Angeles San Francisco Seattle
527 Title Insurance Bldg. 524 Sheldon Bldg. 206 First Ave. So.
Portland Spokane
410 Board of Trade Bldg. 405 Sherwood Bldg.
Administrative and General Offices : Chicago, Ill.

We believe that you can profitably co-operate with Dunham Service. May we explain?

“Ideal” Elevator Door Hardware



Put your specifications for elevator door hangers on a service basis.

Absolutely the best from the viewpoint of convenience, safety, and all around satisfaction.

Richards-Wilcox elevator door hardware installations are going in the biggest and finest buildings in the country.

This alone is sufficient to warrant your careful investigation of Richards-Wilcox features.

Write for Catalogue O-15.

Richards-Wilcox Mfg. Co.
A Hanger for any Door that Slides.

CHICAGO ST. LOUIS LOS ANGELES PHILADELPHIA AURORA, ILLINOIS, U.S.A. LONDON, ONT. BOSTON NEW YORK MINNEAPOLIS SAN FRANCISCO



An Illuminating Triumph

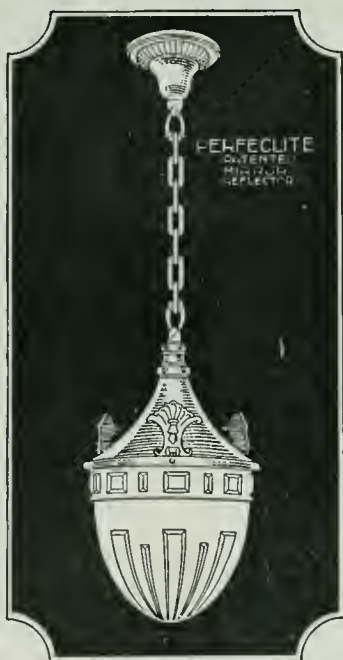

"Faster and Faster they come to Perfeclite"—is no idle slogan. It is a concrete fact that goes a long way to prove that this unusually efficient fixture is really a triumph of the illuminating engineers' art. Homes, shops, stores, buildings and institutions everywhere, are rapidly

adopting the Master Lighting Fixture in order to profit by its illuminating benefits and current savings.

Study this new fixture in our showrooms—then specify it for that client who demands the ultra modern and best. Over 50 different styles—a type for every residential or industrial requirement. Each one contains the famous patented battery of mirrors—a principle of lighting never before used. Our illuminating specialists are ready to serve you at all times. Catalog free.

MYERS & SCHWARTZ

75 New Montgomery St.
San Francisco, Calif.
Phone Sutter 6178

1119 So. Los Angeles St.
Los Angeles, Calif.
Phone 15466



Pitcher Sliding Door in Living Room

Pitcher's *Disappearing Doors*

adjustable Hangers and Frames
meet the demand for Appearance,
Quietness and Durability.

Manufactured by

NATIONAL MILL & LUMBER CO.

318 Market Street, San Francisco



FULLER & GOEPP

32 Page Street, San Francisco. Telephone Market 499
PRIVATE EXCHANGE CONNECTING ALL DEPARTMENTS

MANUFACTURERS OF

MIRRORS, ART AND LEADED GLASS

Dealers in **WHITE** Glass for Table Tops, Counter Tops, Sink
Backs Etc. Complete Stock — Prompt Deliveries.

Passenger and Freight Elevators



"MADE IN SAN FRANCISCO"

Factory and Warehouse, 166-180 Seventh
Street, San Francisco. Phones: - Market
1534 and 1535

SPENCER ELEVATOR COMPANY



RA-DO FUMELESS GAS **RADIATORS**

ALL CAST IRON—3 Sizes (3, 5, and 7 Sections)

The Ideal "Year-Round" Heating System
For The Home—New or Old

Easiest and Cheapest to Install
Lowest Operating Cost

BAIRD - BAILHACHE COMPANY

MANUFACTURERS

478 Sutter St., San Francisco

'Phone Sutter 6858

OLD MISSION PORTLAND CEMENT COMPANY



Each shipment of "OLD MISSION" Portland Cement is guaranteed not only to equal but to surpass all requirements of the standard specifications for Portland Cement as adopted by the U. S. Government and by the American Society for Testing Materials. A Guarantee Certificate is mailed with the bill of lading of each car, giving number of car, date packed, and number of barrels, over the signature of the chief chemist.

8000 SACKS DAILY

SALES OFFICE:
MILLS BLDG., SAN FRANCISCO
PHONE SUTTER 3075

PLANT:
SAN JUAN, CAL.

Insulex

This new heat insulation not only excels in durability and efficiency as a steam pipe covering but is especially adaptable to refrigeration practice.

AMERICAN INSULEX COMPANY

204 BERKELEY BANK BUILDING, BERKELEY

Phone Berkeley 641



Keep Down Insurance Premiums

SPECIFY

FIRE DOORS

Standard Automatic Sliding or Swinging
Tested and Labeled by the Underwriters' Laboratories.

**UNDERWRITERS WINDOWS
STEEL SASH**

U. S. METAL PRODUCTS CO.

330 Tenth Street, San Francisco



Sommerstrom Apartments, opposite Key Route Inn, Broadway, Oakland. Clay N. Burrell, Archt.

CALIFORNIA'S most Fashionable Apartments — those designed for Convenience, Comfort and Luxury—are Equipped with

**HAUSER
WINDOWS**

The owners of this building used Hauser Windows BECAUSE they ARE Easily Operated, Watertight, Dust-proof and Refined in Appearance.

MANUFACTURED BY

Hauser Window Company

157 Minna Street, San Francisco



STATEN COURT APARTMENTS, STATEN COURT and GRAND AVENUE, OAKLAND
SCHIRMER BUGBEE CO., Architects

WHEN the architects designed this beautiful apartment house they sought to combine the practical with the aesthetic.

How successful they were one need only look at the picture which reflects the charm and refinement of a real home.

"ACORN BRAND" oak floors make the interior of this apartment house complete in its exclusive features.

"ACORN BRAND" oak flooring is a Tennessee product, superior in its manufacture.



STRABLE HARDWOOD CO.

First Street, between Washington and Clay
OAKLAND, CALIFORNIA

"LUXOR ENAMEL"

WHITE

HIGH GLOSS

MIRROR-LIKE FINISH

THE FINEST ENAMEL MADE FOR INTERIOR WORK

HIGH IN QUALITY — MEDIUM IN PRICE

UHL BROS., Inc.

SEATTLE

LOS ANGELES

PORTLAND

SAN FRANCISCO

OAKLAND

LEADER WATER SYSTEM

No country home is complete without this modern water system. Running water under pressure whenever and wherever needed. Convenient, economical, sanitary.

**Pacific Pump & Supply
Company, Distributors**

851-853 Folsom Street
SAN FRANCISCO, CALIF.

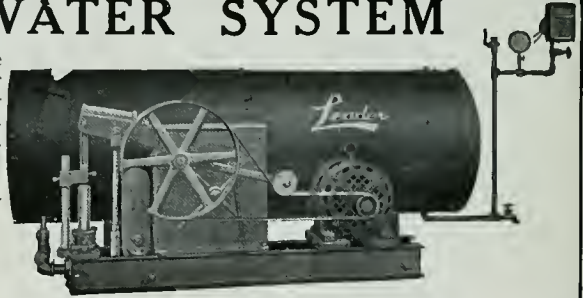

QUALITY HARDWARE



LOCKS AND BUILDERS'
HARDWARE

PALACE HARDWARE CO.

"San Francisco's Leading Hardware Store"

581 MARKET STREET. SUTTER 6060



Pack your Radiator Valves with
Palmetto Twist Packing

It can be unstranded to fit any
size valve. It does not get hard.

H. N. COOK BELTING CO.

401-433 Howard St.

San Francisco, Cal.

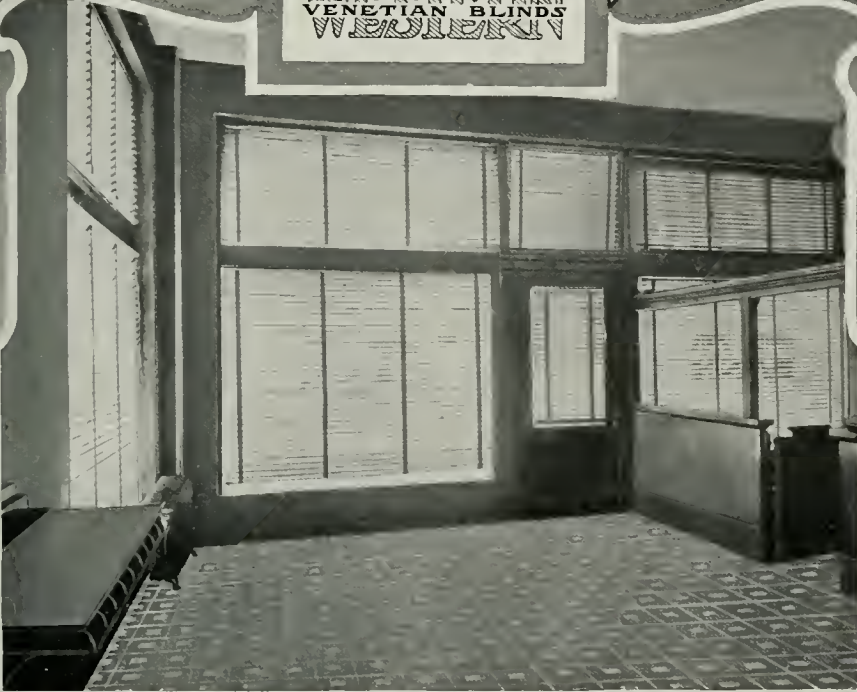

INTERIOR - FARMERS STATE BANK, CHICKASHA, OKLA.
SHOWING WESTERN VENETIAN BLINDS ON WINDOWS -



WILDWOOD, N.J.

INDIRECT DAYLIGHT
~ for Banking Rooms ~



CLEARWATER, FLA.

From Coast to Coast
**WESTERN VENE-
TIAN BLINDS** are
satisfactorily serving hun-
dreds of modern banks,
office buildings, schools,
etc.



MOUNDRIDGE, KAN.



LOS ANGELES, CAL.



NEW FRANKLIN, MO.



INDIANAPOLIS, IND.

*Let us send you illustrated booklets and general
details and specifications.*

WESTERN BLIND & SCREEN CO.
27th AND LONG BEACH AVE.
LOS ANGELES, CAL.

United States Steel Products Co.

Rialto Bldg., San Francisco

SELLERS of the products of the American Bridge Co., American Sheet and Tin Plate Co., American Steel and Wire Co., Carnegie Steel Co., Illinois Steel Co., National Tube Co., Lorain Steel Co., Shelby Steel Tube Co., Tennessee Coal, Iron and Railroad Co., Trenton Iron Co.

MANUFACTURERS OF

Structural Steel for Every Purpose—Bridges, Railway and Highway—"Triangle Mesh" Wire Concrete Reinforcement—Plain and Twisted Reinforcing Bars—Plates, Shapes and Sheets of Every Description—Rails, Splice Bars, Bolts, Nuts, etc.—Wrought Pipe, Trolley Poles—Frogs, Switches and Crossings for Steam Railway and Street Railway—"Shelby" Seamless Boiler Tubes and Mechanical Tubing—"Americore" and "Globe" Rubber Covered Wire and Cables—"Reliance" Weatherproof Copper and Iron Line Wire—"American" Wire Rope, Rail Bonds, Springs, Woven Wire Fencing and Poultry Netting—Tramways, etc.

United States Steel Products Co.

OFFICES AND WAREHOUSES AT
San Francisco - Los Angeles - Portland - Seattle



Specify **BOWSER**

ESTABLISHED 1885

Thirty-five years ago Bowser blazed the trail to efficient gasoline and oil storage and handling. Today Bowser offers accurate, economical and safe equipment for solving all gasoline and oil storage and service problems—backed by those thirty-five years experience. Whether it's in a garage, a railroad, factory or dry cleaning plant, you are serving your client best when you specify Bowser Equipment.

—Write for Illustrated Booklet A-03—

S. F. BOWSER & COMPANY, Inc.

1303 Creighton Ave., FORT WAYNE, INDIANA
Sales Offices (with Service Departments) throughout the United States and in Principal cities of the World.

612 Howard Street,
San Francisco, Calif.

1225 So. Olive Street,
Los Angeles, Calif.

LONDON

PARIS

HAVANA

SYDNEY



*Walls finished with Cabot's Old Virginia White
Roof finished with No. 3 1/2 Dark Gray Creosote Stain
Walter Boschen, Architect, St. Joseph, Mo.*

The soft, brilliant "whitewash white" of the Old Virginia White is particularly suitable for this type of house, and the rich greens and velvety dark gray stains harmonize perfectly for the roof, with the old New England dark green blinds.

Samples and information sent on request

SAMUEL CABOT, Inc., Mfg. Chemists, Boston, Mass.

Cabot's Creosote Stains, Waterproof Cement, and Brick Stain
"Quilt" Conservo Wood Preservative, Damp-Proofing
Protective Paints, Waterproofing, etc.

Pacific Materials Co., San Francisco
Waterhouse-Wilcox Co., Los Angeles

Theo. F. Snyder, San Diego, Cal.

S. W. R. Dally, Seattle
Timms, Cress & Co., Portland

The Latest Country-house Color-schemes

An especially appropriate and harmonious exterior color-treatment has been developed for the dignified and beautiful type of country-house that our leading architects have now firmly established, in place of the fifty-seven varieties that have prevailed in recent years.

Cabot's Old Virginia White,
for the walls

**Cabot's Creosote Stains, in
greens or dark gray, for the roofs**



CENTRAL HIGH SCHOOL, MINNEAPOLIS, MINN.

Architect, William B. Ittner

Contractors, Pike & Cook Co.

Glazed by Forman, Ford & Co.



The above Trade-Mark
appears on every light

Completely equipped with American Window Glass Co.'s Double Strength AA Quality
First Choice of Leading Architects

Because of its absolute dependability, American Window Glass has been used in many fine buildings. Our care in inspection practically eliminates all imperfections and assures uniformity in thickness.

American Window Glass Co., General Office, Pittsburgh, Pa.

DOMESTIC SALES OFFICES

New York, 220 Fifth Avenue
Chicago, 1011 Peoples Gas Building
Boston, Mass., 43 Tremont Street
San Francisco, Cal., 862 Mission Street
St. Louis, Mo., 1303 Syndicate Trust Building
Memphis, Tenn., 440 North Main St.
New Orleans, La., 904 Hennen Bldg.
Atlanta, Ga., 1408 Candler Building

EXPORT SALES OFFICES

Havana, Cuba, Apartado No. 930
Buenos Aires, Argentina
Mexico City, Mex., Apartado Postal No. 237
Barranquilla, Colombia
Bogota, Colombia
Valparaiso, Chile
Lima, Peru
Toronto, Canada, 205 Continental Life Building



HERE IS SHOWN THE HANDY HOPPER DOOR OF

The
KERNER
"Built-in-the-Chimney"
INCINERATOR

which burns all garbage without a penny of cost. Into it is put all waste—everything from kitchen refuse to tin cans, and bottles.

The material deposited falls down the chimney flue to the incinerator built into the base of the chimney. Here it is ignited and burns itself up. The dry waste in burning dries the wet waste so it, too, can burn.

SANITARY — ECONOMICAL — CONVENIENT — ODORLESS

KERNER INCINERATOR CO.

377 O'Farrell St. SAN FRANCISCO Factory, 8 Stanford St.



TRADE MARK

SIMPLEX BURNERS

For High or Low Pressure Boilers, Water Heaters, Kiln Dryers, Furnaces, Etc. Operated by Fractional H. P. Motors. Guaranteed for Efficiency and Durability.

BUNTING IRON WORKS

Factory BERKELEY

1215 FIRST NATIONAL BANK BLDG.
SAN FRANCISCO Phone Sutter 3225

Member of the Oil Burners Manufacturers' Association of California.

Fess System Turbine Fuel Oil Burner

The latest word in the science of burning fuel oil in an efficient and economical method

Ask for Bulletin No. 20

FESS SYSTEM CO., Inc.

1310 S. HILL ST.,
LOS ANGELES

218-220 Natoma Street, San Francisco

HOUSTON,
TEXAS

Member of the Oil Burners Manufacturers' Association of California.

OIL BURNER EQUIPMENTS

Low Pressure Air and Rotary Mechanical Atomizing Types

Refrigerating and Ice-Making Machines

Direct Expansion and Brine Circulating Systems

T. P. JARVIS MANUFACTURING CO.

CONTRACTING ENGINEERS AND MANUFACTURERS

275 Connecticut Street, San Francisco

Phone Market 3397

Member of the Oil Burners Manufacturers' Association of California.

JOHNSON'S ROTARY CRUDE OIL BURNER

Can be installed in any BOILER or FURNACE

Gives Satisfactory Results. Simple to Operate—
Automatic—Safe. Let us tell you more about this
Oil Burner.

S. T. JOHNSON CO.

1337 Mission Street - San Francisco, Cal.

Ask for Bulletin No. 28

Phone Market 2759

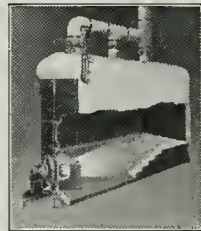

BURNER IN OPERATION

Agencies: SEATTLE LOS ANGELES FRESNO SAN DIEGO SACRAMENTO

Member of the Oil Burners Manufacturers' Association of California.



Pump Governors
 Oil Burner Governors
 Reducing Valves
 Safety Valves
 Oil Valves
 Blowoff Valves
 Boiler Feed Water
 Regulators

Oil Pumping Sets
 Little Giant Improved
 Oil Burners
 Duplex Oil Pumps
 Rotary Oil Pumps
 Oil Heaters
 Draft Gauges
 Boiler Feed Pumps

G. E. WITT CO., Inc.
ENGINEERS

Manufacturers and Distributors

862-864 HOWARD ST.

Phone Douglas 4404

SAN FRANCISCO, CAL.



THERE is no other water-
 proofing "Just as good" as
 "MEDUSA"

The "Original" waterproofing under which other pastes and
 powders are licensed.

PACIFIC MATERIALS CO.
 525 MARKET STREET, SAN FRANCISCO

A. F. Edwards, Pres.
 J. M. Fabbris, Vice-Pres.
 J. A. Mackenzie, Secy.

Office Telephone:
 MARKET 5070

Chas. F. Eisele, Asst. Mgr.
 J. Rubiolo, Asst. Mgr.
 D. A. Batsford, Asst. Mgr.

**AMERICAN
 MARBLE & MOSAIC CO.**

25-59 Columbia Square, San Francisco, Calif.
 Near Folsom St., Bet. 6th and 7th Sts.

Factory on Waterfront, South San Francisco. Phone South San Francisco 161



DETROIT STEEL PRODUCTS CO., Detroit

Direct Factory Branch, 68 Post Street, San Francisco

Phone Sutter 125



The Architect and Engineer

CONTENTS FOR MAY, 1921

	PAGE
HUMANITY IN APARTMENT HOUSES	48
<i>Irving F. Morrow</i>	
RECOMMENDED PRACTICE FOR CONCRETE HOUSE CONSTRUCTION	68
SUGGESTIONS ON DESIGNING OF FORMS FOR CONCRETE WORK	71
PUTTING "FIREPROOF" TO THE PROOF	72
MEXICAN INFLUENCE IN CALIFORNIA ARCHITECTURE <i>Cazenove Lamar</i>	75
LATTER DAY SAINTS HOSPITAL, IDAHO FALLS, IDAHO <i>H. Newton Thornton, Architect</i>	81
HOW LONG DOES AN OFFICE BUILDING LAST?	86
THE ARCHITECT'S SERVICE TO THE COMMUNITY AND HIS OPPORTUNITY TO MAKE BETTER CITIES	89
<i>Robert D. Kohn</i>	
METAL LATH FOR STUCCO HOUSES	93
<i>Zenas W. Carter</i>	
DEPARTMENT OF SAFETY	97
EDITORIAL	102
WITH THE ARCHITECTS	105
WITH THE ENGINEERS	109
ELECTRICAL DEPARTMENT — ELECTRICAL EQUIPMENT OF THE MODERN THEATRE	111
<i>Chas. Felix Butte</i>	
THE CONTRACTOR	117

PUBLISHED MONTHLY BY

THE ARCHITECT AND ENGINEER, INC.
626-27 FOXCROFT BUILDING, SAN FRANCISCO

W. J. L. KIERULFF
President

FREDERICK W. JONES
Vice-President

L. B. PENHORWOOD
Secretary



DOORWAY, HOUSE FOR MR. JESSE ROBINSON, CLAREMONT MANOR, CALIFORNIA
WILL E. SCHIRMER AND ARTHUR S. BUGBEE, ASSOCIATE ARCHITECTS

THE ARCHITECT AND ENGINEER

MAY
1921



Vol. LXV
No. 2

Humanity in Apartment Houses

By IRVING F. MORROW

ALTHOUGH the view across the way embraces attractive houses and receding villas and a distant prospect of hills alternately blue and tawny with the changing seasons, I can never look out by the front windows without a (figurative) shudder of apprehension. Why, one may well ask, such disturbance in the presence of a quiet and beautiful scene? To be brief, then, on the corner opposite my own home lies a choice and good-sized lot—vacant. Not that a vacant lot is objectionable *per se*. In this particular one, meadow larks warble among the owl's clover and lupines. In fact, it is an outlook more agreeable than many a house I know. But—and here's the rub—a vacant lot is a potential apartment house. I probably need offer no further explanation of my perturbation.

Yet, theoretically, what justification should there be for such an attitude? Several questions suggest themselves. Why should a home owner fear or resent the advent of an apartment house in the vicinity of his property? Is there anything in the nature of the apartment house problem which of necessity precludes the application of the fundamental principles of composition and the accepted canons of taste? Why is the real estate agent generally the only party to exercise imagination in connection with an apartment house? Why will people of apparent culture and refinement pay large rents for poor quarters in buildings devoid alike of beauty and domestic suggestion? These and similar questions offer legitimate lines of inquiry; although they seem to be leading away from architecture properly speaking toward the domain of abnormal psychology.

To one who maintains a rational and constructive attitude toward the art of architecture, it would seem unreasonable to assume that there exist certain favored (or unfavored) problems which are inherently insoluble. This or that

particular type of building, by its nature, may widen or restrict the scope for the play of abstract beauty as expressed in terms of the traditional architectonic apparatus. But, generally speaking, for every structure which is required there must exist a possible expression which is natural and appropriate—and hence interesting. On such terms only is there significance in our hope that the art may fulfill in any vital and constructive way its obligation to a life which is undergoing endless development. Failure results ordinarily from one or more of a small class of causes—economic mal-adjustment; social mal-adjustment; idiosyncrasies of the individual client; and (more often than it might be pleasant to admit) incompetence of the individual designer.

The small and moderate-sized apartment building enjoys a unique position at the bottom of the aesthetic scale because it is apt to suffer simultaneously from all four disabilities. The amount of money available is too frequently

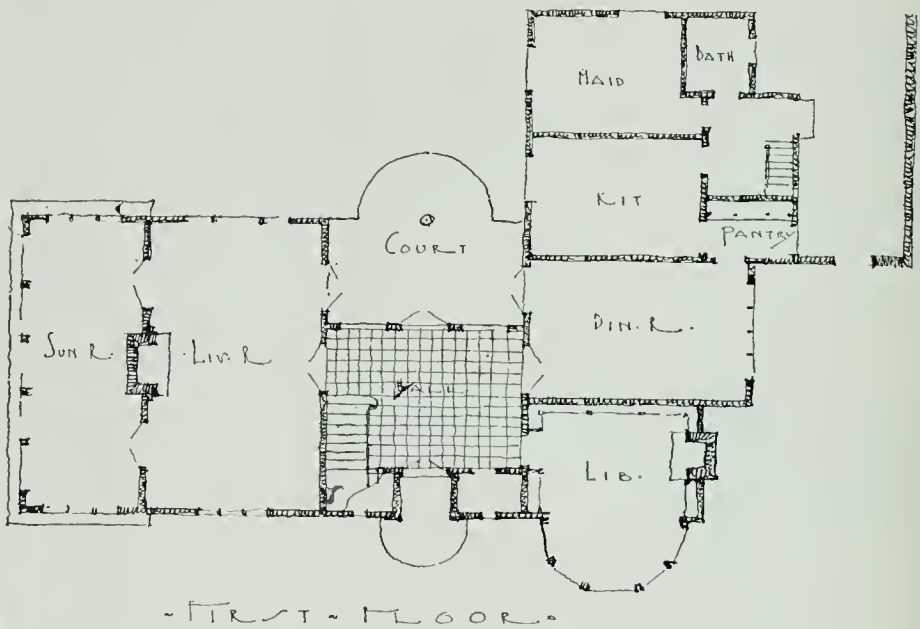

FIRST FLOOR PLAN, HOUSE FOR MR. JESSE ROBINSON,
CLAREMONT MANOR, CALIFORNIA

Will E. Schirmer and Arthur S. Bugbee, Associate Architects

insufficient to do the thing on any humanly proper basis and reap the desired profit (the only incentive); tenants are furnished meretricious buildings, not, as owners and agents would have us believe, because they demand them, but because they consent to tolerate them; builders are actuated more by a timid cupidity and a petty subservience to precedent than by an enlightened vision; and (part and parcel of the petty policy of saving pennies) second- or third-rate draftsmen are employed to do work which requires the ability of first-rate architects. What wonder, then, that the small apartment is inferior in planning, in construction, and in design both without and within? Nor should there be difficulty in placing the ultimate responsibility. The fault must rest on the tenants' shoulders. As long as they are willing to accept poorly designed quarters, no multiplication of architectural schools or associations of prac-

tioners will serve as a preventive. As soon as the demand for well designed ones becomes general, it will become apparent that the thing can be done.

As a matter of fact, it is even now being done—once in a while. Looking over the photographs of the work of Messrs. Schirmer and Bugbee—or looking over the buildings, which, as a matter of fact, I had previously known—I have felt that, were I only assured that the lot across the street were to be occupied by one of their apartment buildings, I could look out by my front windows with equanimity. I might then rest secure in anticipating a building coherent in composition, refined in taste, human (man's size) in scale, domestic in feeling, and respectable in execution. As general requirements, these sound like not unreasonable demands to be made of any building destined for human habitation. As a matter of sad fact, we all know well enough that they are rarely realized in the current moderate-sized apartment house.

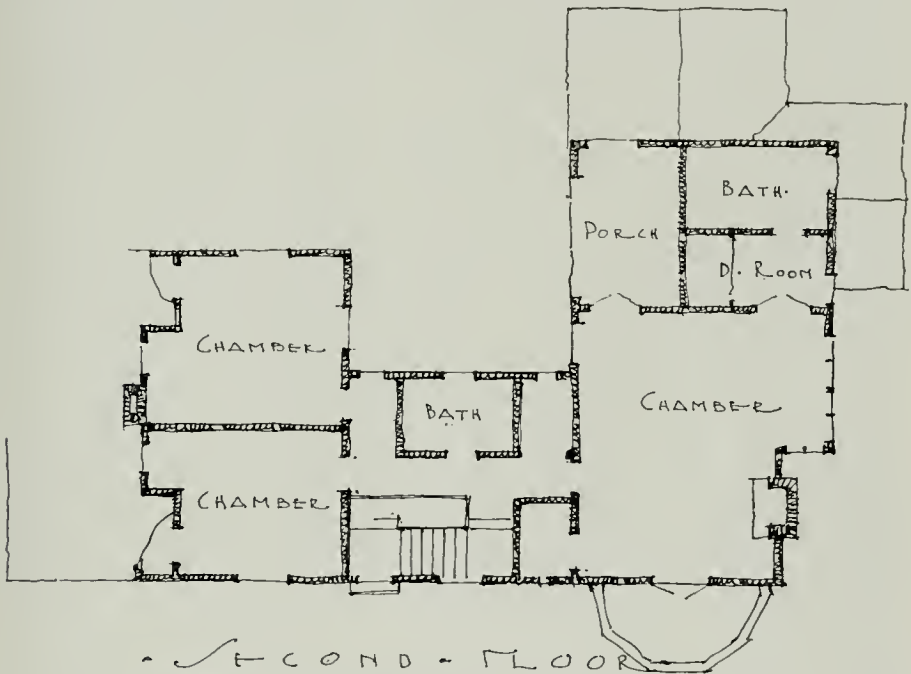

SECOND FLOOR PLAN, HOUSE FOR MR. JESSE ROBINSON,
CLAREMONT MANOR, CALIFORNIA
Will E. Schirmer and Arthur S. Bugbee, Associate Architects

If the emphasis seems to neglect by implication the private residences which Messrs. Schirmer and Bugbee have designed, it is not that they lack the same merits and charm which have just been singled out, but because they are, after all, less unusual. There are among us an encouraging number of architects who have accustomed us to private houses of similar character and equal quality. We accept it, in medium sized domestic work, as the normal thing (not being for that reason the less appreciative). But the field of the medium-sized apartment seems to be one in which they appear in the role of pioneers. Their work—anomalous as it may seem to be compelled to say so—is almost unique. And though it perform no other service, it must surely dispose of the time-worn argument that it is impossible to do an attractive apartment house.



HOUSE FOR MR. JESSE ROBINSON, CLAREMONT MANOR, CALIFORNIA
WILL E. SCHIRMER AND ARTHUR S. BUGBEE, ASSOCIATE ARCHITECTS



HOUSE FOR MR. JESSE ROBINSON, CLAREMONT MANOR, CALIFORNIA
WILL E. SCHIRMER AND ARTHUR S. BUGBEE, ASSOCIATE ARCHITECTS



SUN ROOM, HOUSE FOR MR. JESSE ROBINSON,
CLAREMONT MANOR, CALIFORNIA



DINING ROOM, HOUSE FOR MR. JESSE ROBINSON,
CLAREMONT MANOR, CALIFORNIA
Will E. Schirmer and Arthur S. Rugbee, Associate Architects



DRAWING ROOM, HOUSE FOR MR. SAM J. NEWMAN, PIEDMONT, CALIFORNIA



LIVING ROOM, HOUSE FOR MR. RUDOLF DRUHE
Will E. Schirmer and Arthur S. Bugbee, Associate Architects

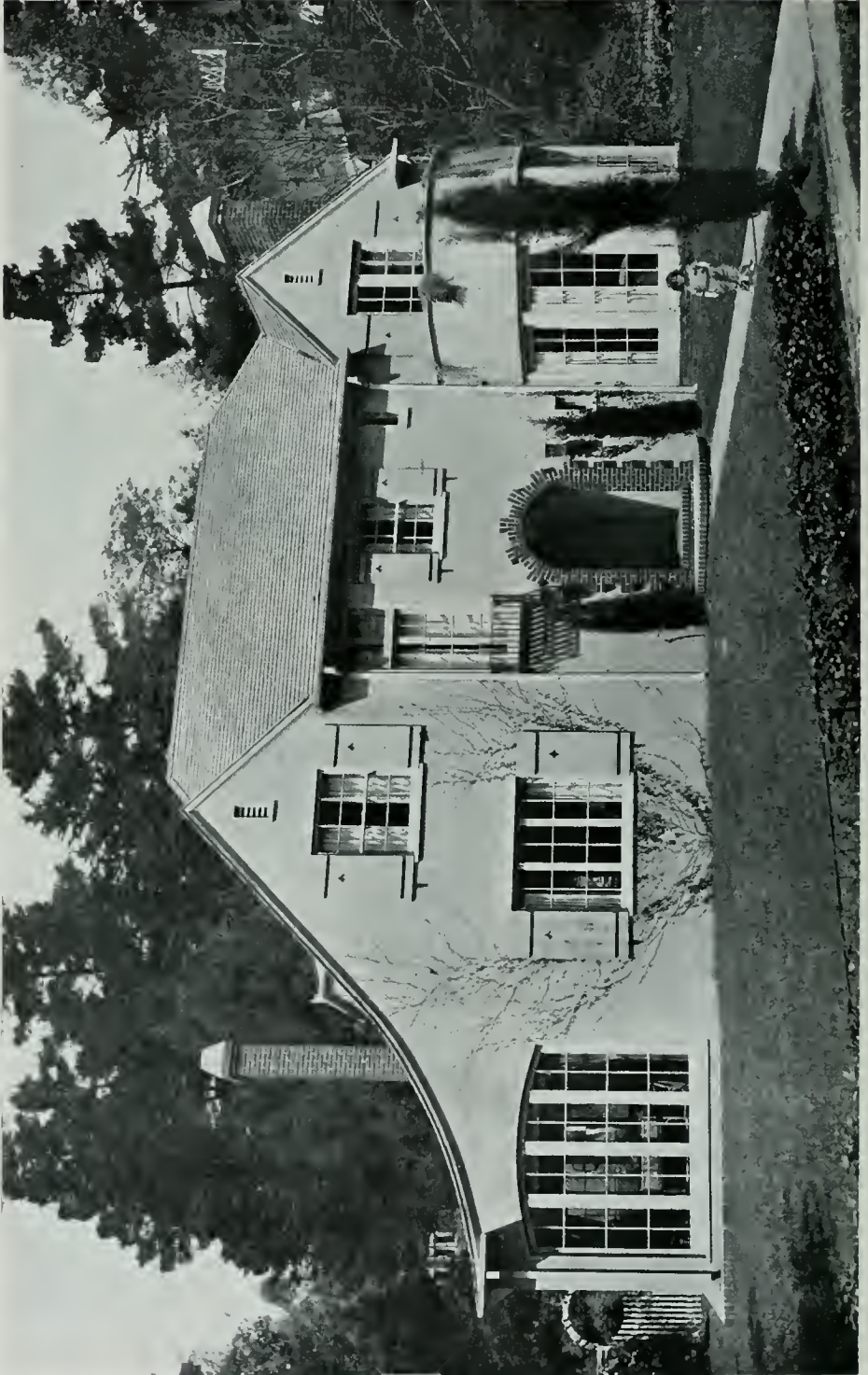

HOUSE FOR MR. JESSE ROBINSON, CLAREMONT MANOR, CALIFORNIA
WILL E. SCHIRMER AND ARTHUR S. BUGBEE, ASSOCIATE ARCHITECTS



HOUSE FOR MR. SAM J. NEWMAN, PIEDMONT, CALIFORNIA. WILL E. SCHIKMER AND ARTHUR S. BUGBEE, ASSOCIATE ARCHITECTS

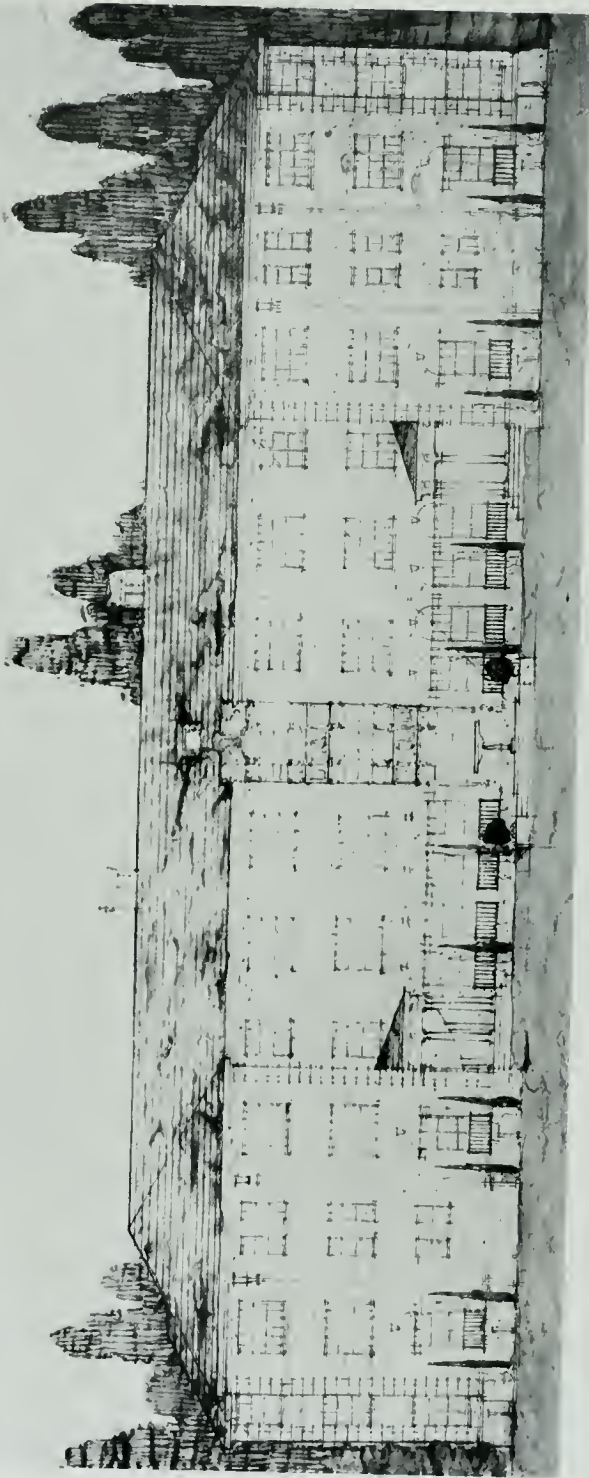

APARTMENT HOUSE FOR MRS. P. C. RENAULT, OAKLAND, CALIFORNIA.
WILL E. SCHIRMER AND ARTHUR S. BUGBEE, ASSOCIATE ARCHITECTS



CAVARYL COURT APARTMENTS, OAKLAND, CALIFORNIA. WILL E. SCHIRMER AND ARTHUR S. BUDGE, ASSOCIATE ARCHITECTS

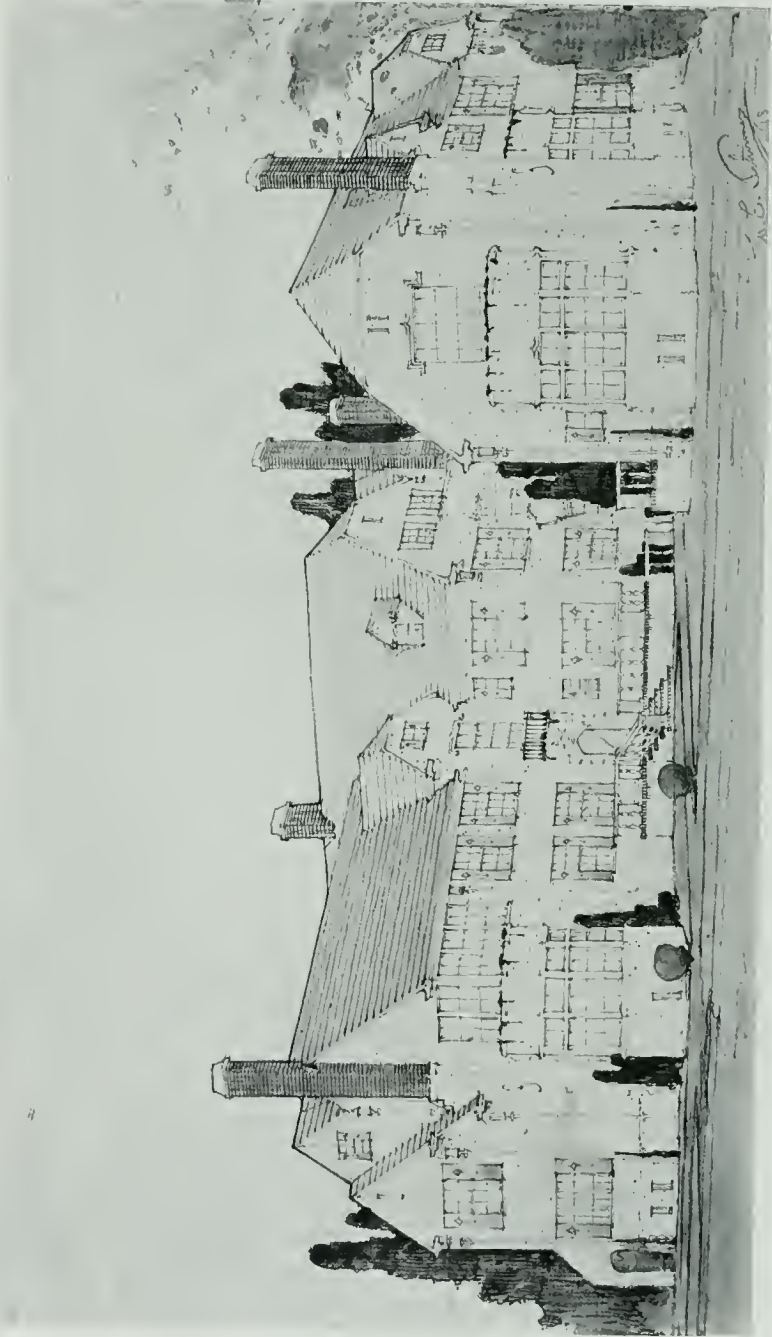

L. B. HOGE APARTMENTS, OAKLAND, CALIFORNIA. WILL E. SCHIRMER
AND ARTHUR S. BUGBEE,
ASSOCIATE ARCHITECTS



L. B. HOGE APARTMENTS, OAKLAND, CALIFORNIA. WILL E. SCHIRMER
AND ARTHUR S. FUGBEE, ASSOCIATE ARCHITECTS



L. B. HOGE APARTMENTS, OAKLAND, CALIFORNIA. WILL E. SCHIRMER AND ARTHUR S. BUGBEE, ASSOCIATE ARCHITECTS



STATEN COURT APARTMENTS, OAKLAND, CALIFORNIA, WILL E. SCHIRMER AND ARTHUR S. BUGBEE, ASSOCIATE ARCHITECTS

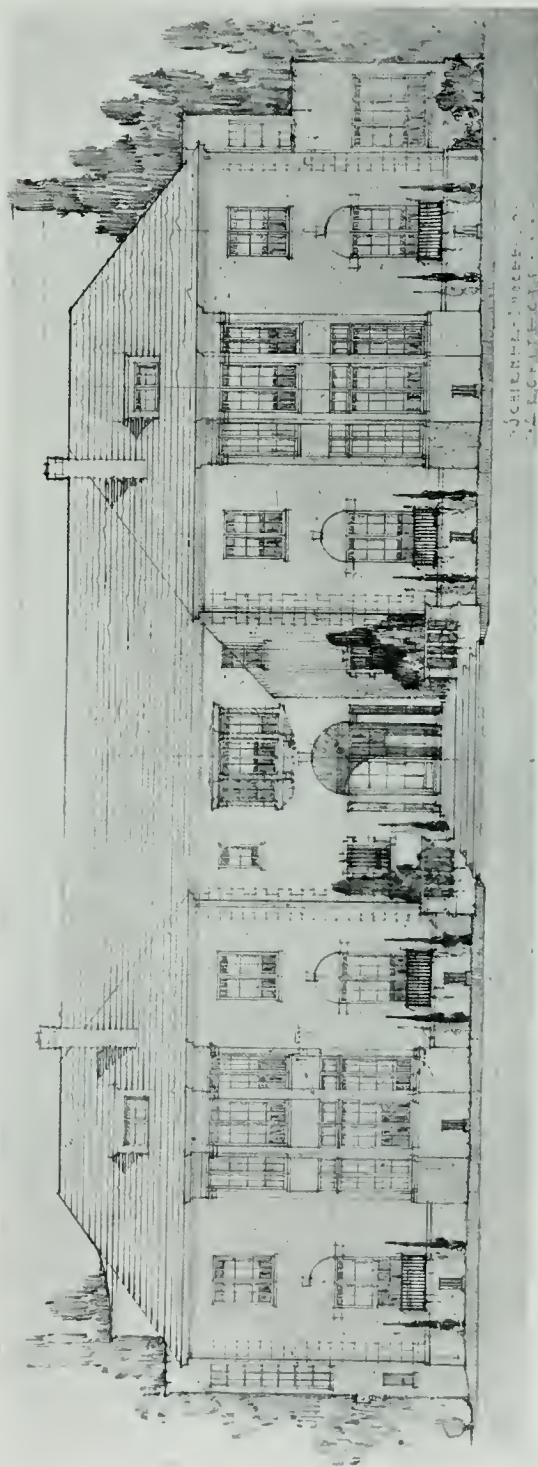

STATEN COURT APARTMENTS, OAKLAND, CALIFORNIA, WILL E. SCHIRMER AND ARTHUR S. BUGBEE, ASSOCIATE ARCHITECTS

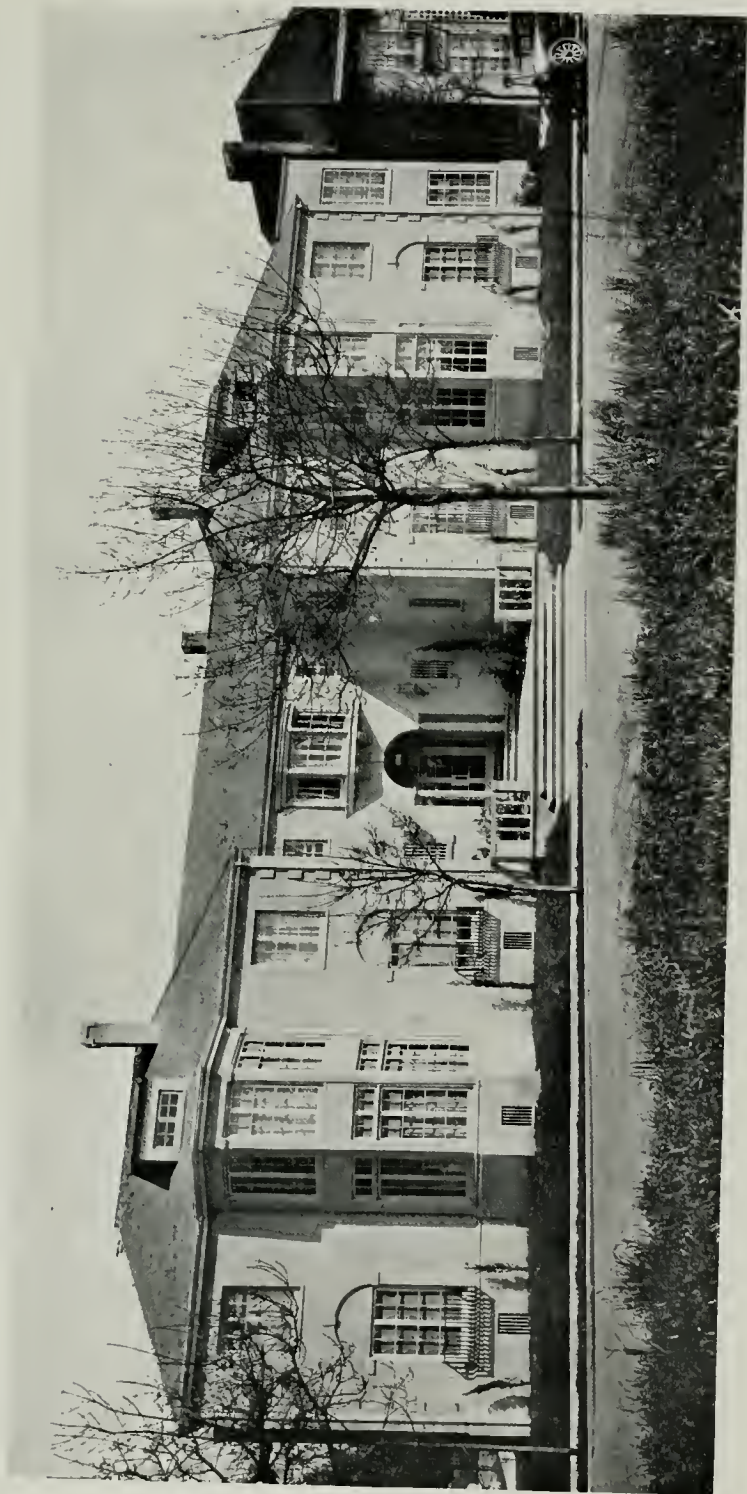

STATEN COURT APARTMENTS, OAKLAND, CALIFORNIA. WILL E. SCHIRMER AND ARTHUR S. BUGBEE, ASSOCIATE ARCHITECTS



HOUSE FOR JANE P. RAWLINGS, PIEDMONT, CALIFORNIA. WILL E. SCHIRMER AND ARTHUR S. BUGBEE, ASSOCIATE ARCHITECTS



HOUSE FOR MR. T. W. FORREST, OAKLAND
(See next page)



HOUSE FOR MR. A. L. GROSSMAN, OAKLAND (See next page)
Will E. Schirmer and Arthur S. Bugbee, Associate Architects



HOUSE FOR MR. A. L. GROSSMAN, OAKLAND
(See preceding page)



HOUSE FOR MR. T. W. FORNEFT, OAKLAND (See preceding page)
Will E. Schirmer and Arthur S. Bugbee, Associate Architects



HOUSE FOR MR. E. M. WILSON, SAN FRANCISCO
Will E. Schirmer and Arthur S. Bugbee, Associate Architects

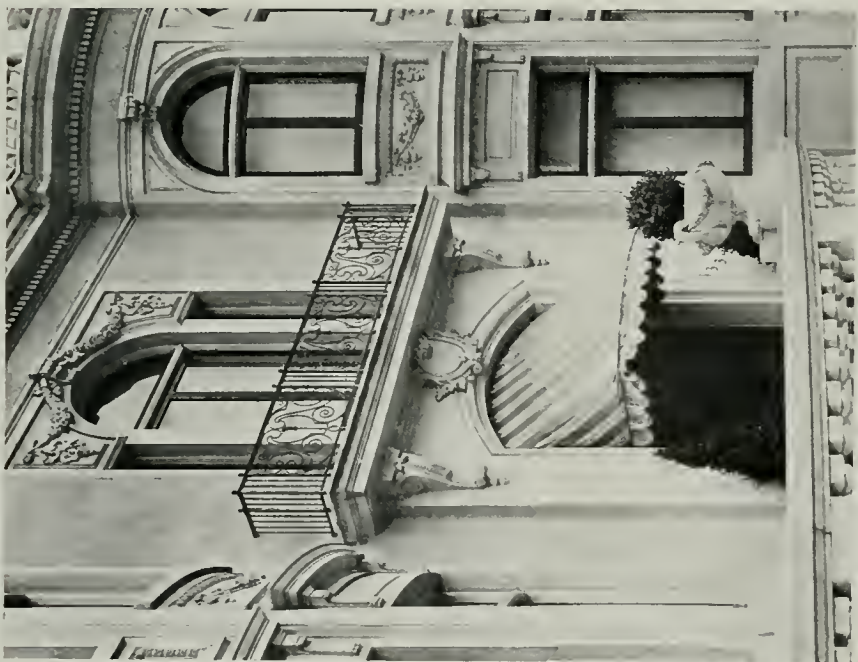

HOUSE FOR MR. E. M. WILSON, SAN FRANCISCO

Recommended Practice for Concrete House Construction

AT THE recent convention of the American Concrete Institute the Committee on Concrete Houses, of which Mr. Emile G. Perrot is chairman, submitted as its report a tentative draft of recommended practice for concrete house construction. The report is confined to a consideration of the monolithic, unit constructed and plastered or gunite types. It probably will be revised before its final presentation and adoption by the Institute. The main features of the report follow:

This recommended practice shall apply to the construction of houses not over three stories in height and not exceeding 30 ft. in height between top of first floor and under side of third floor ceiling.

(a) Basement and foundation walls of monolithic concrete shall be not less than 6 in. in thickness and shall be supported on a concrete footing or basement floor sufficient to prevent settlement of the building. The design of these footings shall be based on the ability of the foundation soil to carry loads and the monolithic character of the concrete wall and footing or basement floor shall be considered in determining the required bearing area on the soil. Basement walls shall be designed to resist the horizontal pressure of the earth in contact with the exterior of the wall.

(b) Basement walls of precast units bonded together by registering or interlocking projections or depressions, grouted in place, or by reinforcing bars across joints embedded in cement mortar, shall have a minimum thickness of 7 in., or not less than the minimum thickness of exterior bearing wall of superstructure. The precast units shall conform in strength, quality and absorption to the requirements of Recommended Specifications and Building Regulations presented by the Committee on Concrete Products of the American Concrete Institute.

Note 1.—Allowing a total of 50 lb. per square foot roof load, 75 lb. per square foot for second and third floors, and 100 lb. per square foot for first floor, including weight of walls, the unit compressive stress per square inch on a 6-in. basement wall would be slightly in excess of 100 lb. The unit stress produced by the overturning effect of the wind on the side of the house would not materially increase this. The effect of the pressure on earth filling against the house is in a majority of cases small as compared with the vertical load of the superstructure and cannot materially affect the stability of a monolithic or properly bonded precast unit wall.

Walls.

(a) The thickness of single exterior bearing walls of plain concrete shall be not less than 4 in. thick, but when reinforcing in excess of 2 to 3 per cent is used, the thickness shall be determined by the usual methods of reinforced concrete design for vertical loads and for a uniform wind load of 30 lb. per square foot on exposed surface.

(b) The thickness of the bearing wall, of double or triple concrete walls shall conform to paragraph (a), this section, except that the thickness required to carry the loads may be reduced by the actual working shear value of ties between the walls.

(c) Exterior walls which act merely as curtain walls between reinforced concrete columns or studs shall be designed to withstand a wind pressure of 30 lb. per square foot on the exposed surface. Reinforced concrete curtain walls may be constructed by plastering and back plastering on expanded metal or wire mesh reinforcement, or shot with a cement gun or by other mechanical means of placing concrete or stucco.

(d) Exterior walls of precast units bonded together by registering or interlocking projections and depressions, grouted in place shall conform in thickness to the schedule of wall thicknesses provided for concrete block, brick, tile and architectural trimstone of the Recommended Building Regulations presented by the Committee on Concrete Product of the American Concrete Institute, except that large or small reinforced concrete units connected on two opposite ends to structural members designed to carry all loads to foundations originating from the weight of the building or from wind pressure or which in themselves act as structural members may have a thickness determined by the bending stresses produced by wind pressure of 30 lb. per square foot on the exposed surface.

(e) Solid concrete exterior walls shall be furnished with furring on the inside so as to produce an insulating air space between the interior finish and the concrete wall. Double exterior concrete walls, providing a dead air space between, may be finished without further provision for insulation.

Floors.

Reinforced concrete floors shall be designed to carry a live load of 40 lb. per square foot uniformly distributed. The advantage of continuity in reinforced concrete floors shall not be assumed unless the concrete is placed continuously over intermediate supports for the entire length of the floor, with appropriate reinforcing to take care of negative moments.

Roofs.

(a) Flat concrete roofs shall be designed to carry the dead weight of the roof and 20 lb. per square foot additional for houses constructed in climates subject to heavy snowfall. Sloping roofs shall be designed for 30 lb. per square foot on the vertical projections of the roof surface exposed to the wind.

(b) Concrete roofs without other covering shall be constructed of non-porous aggregates so graded as to produce a dense, impervious concrete. For additional assurance of watertight construction, waterproofing compounds may be used. Reinforcement to the amount of .2 of 1 per cent shall be placed in the top portion of the roof slab to resist temperature stresses.

Materials.

(a) Only standard portland cement, which meets the requirements of the Standard Specifications for Cement of the American Society for Testing Materials, in effect as of Jan. 1, 1921, shall be used in the construction of houses.

(b) All aggregates shall be clean material, free from dust, ashes, lumps of coal, vegetable loam and organic matter.

(c) Cinders may be used as coarse aggregate for partitions and for exterior walls, providing tests show the resulting concrete will average a compressive strength of 10 times the loads to which it will be subjected. Cinders shall be composed of hard, clean, vitreous clinker, free from sulphides, unburned coal or ashes.

(d) Slag used for coarse aggregate shall be clean, dense, air-cooled blast furnace slag containing not more than 1.3 per cent of sulphur and shall weigh not less than 70 lb. per cubic foot when loosely packed.

(e) Rods and bars used for reinforcing shall conform to the requirements of the Specifications of the American Society for Testing Materials for Concrete Reinforcing Bars in effect Jan. 1, 1921. Cold drawn steel wire, made from billets, may be used in floor and roof slabs, column hooping and for temperature and shrinkage stresses. Wire mesh or expanded metal may be used for its full cross-sectional value to resist stresses, providing its component parts meet

the requirements for tests for concrete enforcement bars of the American Society for Testing Materials.

(f) The water used in mixing concrete shall be free from oil, acid, alkalis or organic matter.

Design.

The design of floors, roofs, beams, girders and columns shall be governed by Section 4, "Design," of the American Concrete Institute Standard Specification No. 23.

Construction.

(a) Reinforcement shall be properly located and secured against displacement during the placing of the concrete.

(b) Machine mixing is to be preferred, but where it is necessary to mix by hand, all ingredients shall be turned together until the mass is homogeneous in appearance and color. Hand-mixing shall be done without losing an appreciable amount of mortar. A small batch mixer is most satisfactory.

(c) Only enough water shall be used to produce a consistency such that the concrete will flow sluggishly into the forms and around the reinforcement without separation of aggregates from mortar. Concrete shall be protected against rapid drying out and shall be protected against freezing until it has hardened for at least 10 days in a temperature not less than 35° F. Concrete shall be deposited in the forms not more than 30 minutes after mixing.

(d) Forms shall be substantial and sufficiently tight to prevent leakage of more than 1 per cent of the mortar. They shall not be removed until the concrete has hardened sufficiently to sustain without injury to the concrete the loads that will come upon it. Window and door frames may be set in the forms and the concrete cast around them. Wooden frames should be well primed and should be anchored to the concrete by means of long spikes or bolts. They should be braced against distortion from the pressure of fresh concrete.

* * *

Better Building Most Important

IT IS not too sweeping a statement to say that it is more important that buildings erected in the future shall reflect the knowledge, judgment and experience of the best builders than that the ground be cumbered with structures that in their neglect to incorporate the best known in building construction are little better than crimes. If research work is to be done let it pick out the errors of the heating, the plumbing and the roofing and prohibit their repetition as they will be repeated if the whole attention is given to provide more houses regardless of the detail of their construction, the materials of which they are built and the manner in which they are used. In most instances the man who erects buildings erects them for a profit with utterly no consideration for the health, comfort or expense entailed upon those who finally occupy them or own them as homes. If there is anything in civilization or progress in the world, such men should be discouraged until they incorporate in their enterprises the best known in the different fields. It will be well if those who represent plumbing, heating and roofing industries will point out the claims which some building enterprises have incorporated in them in the way of botch work, poor materials and materials poorly suited to the needs so that the public will rise up in arms and demand what experienced, conscientious men know how to do and goods such as discriminating tradesmen use.—Sheet Metal Worker.

Suggestions on Designing of Forms for Concrete Work

BETTER designing of forms was the subject of a paper presented February 17 by Mr. T. Trueman Black, Construction Engineer, Toronto, Ont., before the Toronto branch of the Engineering Institute of Canada. An abstract of the paper follows:

Forms are to be designed so as to (1) keep the semifluid concrete in position; (2) give the concrete such surface as is required by the specifications; (3) support the steel reinforcing; (4) be easily removable without destroying or injuring the concrete surfaces; (5) be cheaply built, erected and removed and (6) be in shape for re-use.

There are certain well known theories and principles underlying the design of forms; but there is a number of other factors depending upon local conditions which will determine the success or failure of the work. For instance, concrete will at one time flow easily, filling the forms completely. At another time, however, due to changes in humidity or temperature, or to slight changes in the aggregate, the concrete seems to have developed a large internal friction, flows through the chutes very sluggishly at the same time sets soon after leaving the mixer. In this case the tamping and spading required to fill the forms brings on them stresses which can only be guessed at. The concrete not being spread evenly throughout the forms, brings uneven loading on them.

To meet some of these conditions the engineer has to make a study of:

Type of structure, whether mass work or other walls. In mass work the forms are heavy, coarser aggregate is used requiring fewer cross-ties. In thin walls, beams, etc., cross-ties can be placed frequently, great strength in the forms is not required on account of the small unsupported spans.

Surfaces. Contractors concede that it is cheaper to make smooth exposed surfaces by using forms with finished surfaces, than by smoothing the concrete after the forms are removed.

Advisability of designing forms so as to be able to re-use them.

The action of cement, whether it is slow or quick, whether it throws the surplus water quickly or not, will make a difference in the pressure against the forms. A quick setting cement has a tendency to produce water streaks upon the surface of the concrete. If the form is tight this effect will be more marked. This is especially evident in steel forms. A slight leakage in the form will improve this defect.

In warm weather the tendency for the cement is to set quicker, causing more streaks upon the surface. The atmospheric conditions may change the flowability of the concrete.

The choice of materials for forms is governed by the number of times it is possible to use them. Timber forms are best used in a structure where only a few repetitions can be made. Steel forms are economical when there is a large number of repetitions in the structure.

Some designers give plans of forms. This is of advantage in arranging construction joints in buildings where high stresses are used. The designer has many chances of saving in cost of formwork by slight modifications in his design. A careful study of formwork will have the tendency to eliminate expensive and difficult form building.

In removing the forms it must be remembered that wooden forms have a tendency to swell, while the concrete shrinks in the process of setting. For the easy removal of forms wedging strips are necessary. It is best to allow a drawing piece for each 10 or 12 feet of form not free to move longitudinally, if the forms are to be removed in sections.

The question of forms is a building question and the method is optional with the builder as long as the forms fulfill their purpose and maintain the structure true to line and free from construction stresses. It is best, however, to give more complete specifications for formwork to relieve the builder from responsibility after the concrete is placed.

* * *

Putting "Fireproof" to the Proof

HOW LONG will a column of given material—steel or brick or reinforced concrete—last in a burning building after it becomes red hot, with the crushing weight of ten or fifteen stories above it? Such a question would seem impossible to answer except by reproducing the actual conditions—putting up a sky-scraper with the specified kind of column and then setting fire to it. And yet tests have now been made in a huge laboratory, built in Chicago for the purpose, with a furnace to furnish the heat and hydraulic rams to simulate the downward pressure of a great structure. During eighteen months columns of all kinds were tested, and architects may now know exactly how each kind will behave under given conditions of heat and superincumbent mass. In an article entitled "Finding Out About Columns," *Safeguarding America Against Fire* (New York), the organ of the National Board of Fire Underwriters, gives the results of these tests, whose value to architects, builders, insurance men, and the general public can scarcely be overestimated. We read:

"The New York Bureau of Buildings conducted several fire tests upon small reinforced concrete columns in connection with floor tests during the years 1903 and 1910. These tests, while useful, failed of their full value because of the impossibility of applying sufficient load to represent working stress conditions on the columns. There was no difficulty in securing proper heat, but adequate loading on columns was impractical.

"At last the solution of the great problem was undertaken by the United States Bureau of Standards, the National Board of Fire Underwriters, and the Associated Factory Mutual Fire Insurance Companies, working conjointly. Plans were worked out, during a period of years, for a series of tests so complete that questions concerning columns in fire-resistant construction might be finally and authoritatively answered. The Underwriters' Laboratories in Chicago seemed to be the one logical place for such a test, and construction work was there begun, upon a testing furnace of unprecedented magnitude and power, for the purpose. It was arranged to supply the desired heat from multiple gas flames of great intensity and then to add the load by an enormous hydropneumatic ram.

"Simultaneously with the construction and standardization of this apparatus there began the work of collecting and preparing the columns for the test. This lasted from May, 1916, to May, 1917. In June, 1917, the tests themselves began, and they continued for eighteen months, but two years more were required for the study of the mass of the data obtained. Now at last the conclusions can be given to the public, which has an interest in the results hardly second to that of the architects and engineers themselves.

"First and last, 106 tests were made, 91 being fire tests alone and 15 being fire and water tests, and the extreme scientific character of the work and the painstaking attention to detail are amazingly evident on every page.

"A visitor to the tests would have found a massively constructed, tile-lined chamber surmounted by a lofty structure of steel framework, pipes, and cylinders. He would have seen some building column taken from the place of storage and carried by a traveling crane to the interior of the chamber, there to be bolted securely into place, and a multitude of refined heat and deformation apparatus adjusted. Then the opening would have been closed and the gas-burners ignited. After a time the observer at the mica window would have seen the column begin to acquire color and then reach a dull glow from the long-continued intensity of the heat. Meanwhile, the ponderous ram of the press would be exerting the steady pressure of imaginary

loaded floors above. Perhaps as he watched the effect he might see cracks open up in the coating and then the slow fall of pieces here and there, exposing the black steel beneath. This steel, in turn, would begin to glow a cherry red and finally to buckle under the tremendous pressure, thus proving its vulnerability.

"The answer in regard to such a column was thereupon plain; it could only be relied upon to support heavy weight in a severe fire for certain definite periods of time, depending upon type of construction and method of protection. No matter what claims might have been previously made in its behalf, the answer of conflagration conditions had been obtained and was now a part of scientific knowledge.

"The results of the tests disclose a wide variation in the length of the fire-resistance period recorded. Unprotected structural steel with a minimum metal thickness of 20/100 of an inch, for example, lasted only ten minutes, and a round cast-iron column, unprotected and unfilled, registered a resistance of only twenty minutes. Filling the interior of such a column with concrete lengthened its resistance to the extent of ten minutes.

"A column of limestone or calcareous gravel concrete reinforced with vertical bars and lateral ties or hooping, on the other hand, showed a fire-resistance of eight hours. A structural steel column, protected by limestone or calcareous gravel concrete, also resisted the flames for eight hours. In this instance the protection was four inches thick and was two inches in the case of the reinforced concrete.

"A structural steel column protected by four inches of trap-rock concrete stood up for five hours, and several of the others showed a fire-resistance of five hours."

Engineers consider that any column withstanding the fire test for four hours is safe, since it is not likely in actual service that the heat would be prolonged for any such period. There would not be sufficient combustible material at hand. In San Francisco it was noted that buildings were burned out at the rate of about one hour per story. It will surprise many engineers and architects, says the Literary Digest, to find that hollow-tile protection for steel columns proved less stable than anticipated, the longest resistance being three hours. Common brick laid flatwise, however, stood up well. To quote further:

"It is believed that the findings of these tests may be applied with confidence to building construction as indicating the types of columns and protections able to resist fires of the duration noted, providing that reasonable care is taken to identify the materials used and to secure the proper grade of workmanship.

"In commenting upon the tests the report says: 'The fire-resistance afforded by columns is based on the time to failure rather than the useful limit, because the former is definitely determined by the test procedure. It is deemed, however, that with the interpretation of test results given, the protection given by the columns and coverings will generally be sufficient to prevent permanent damage of such extent as to require repair or replacement after fire-exposure corresponding in duration to the pertaining resistance periods.'

"An appraisal of the value of these tests to the safety of life and property generally can scarcely be exaggerated, the scientific data secured substituting the absolute for the approximate, and thus eliminating all guesswork in making plans."

* * *

Plenty of Brick

There were 289,435,000 common brick on hand on November first. The peak in the common brick industry was passed recently, according to the Common Brick Manufacturers' Association.

The stocks of brick on hand have increased during the month and these stocks were produced at the highest cost known to the industry. Full seventy-five per cent of the plants are closed down with kilns full. It is not considered profitable to pile out brick, which means an extra handling, and present demand does not warrant the accumulation of larger stocks. Another factor influencing the cessation of manufacture is the general belief that by the time the demand is resumed brick can be manufactured at lower cost.

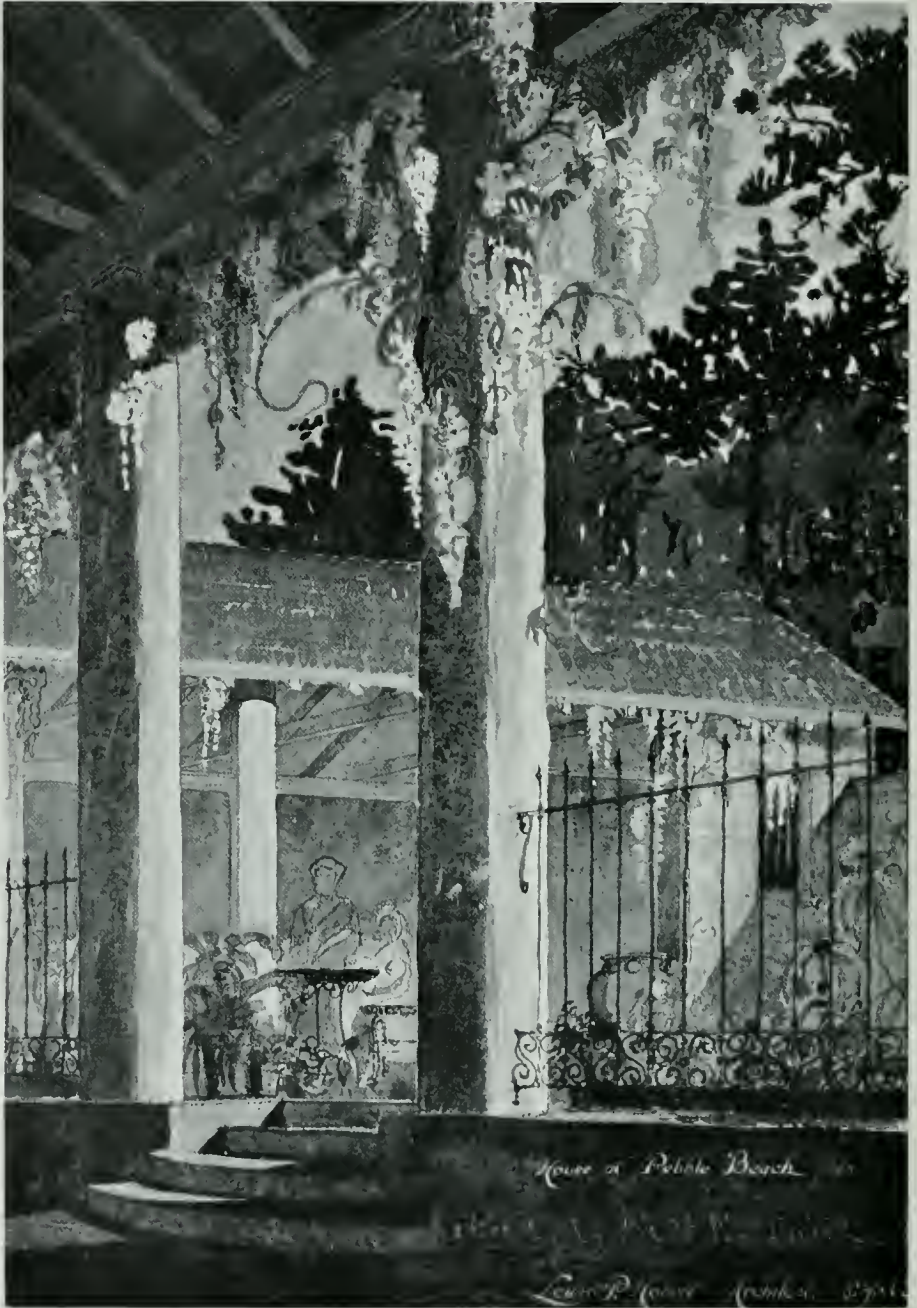

HOUSE AT PEBBLE BEACH, CALIFORNIA
LEWIS P. HOBART, ARCHITECT

Mexican Influence in California Architecture

By CAZENOVE LAMAR

A RECENT charming development of Spanish architecture is the cottage of Mrs. John S. Cravens, at Pebble Beach, California, designed by Mr. Lewis P. Hobart, architect of San Francisco. Since his late visit to Mexico with the San Francisco Chamber of Commerce party, Mr. Hobart is enthusiastic in his desire to return to the Old Spanish style of building, the pioneer architecture of California, many rich examples of which survive in the faded glories of Mexico.

The Cravens residence, though small, demonstrates the artistic possibilities of the low, graceful lines of the rambling Mexican house, combined with the essential practical comforts of modern country life. Surrounded by pine and cypress trees, the house crowns a hill descending gently to the sea, which the south facade faces. Of old ochre tinted stucco walls, roofed with heavy tiles in mottled tones of burnt sienna and browns, the structure encloses a square patio, where are gravelled walks, shrubberies, box hedges, and an oval marble pool, filled with water lilies.

Through the north front, the entrance leads to a loggia running the length of the west side of the patio and tiled with dark blue flags, six strong white columns supporting the roof. From the right of the loggia two thick wooden doors lead into the passage on which four maids' rooms open. Down the length of the loggia, at the farthest end, a glass door opens into the large living-room, where three long French windows, giving on a terrace, take advantage of a southern exposure. This terrace, again, is paved with dark blue and white flags, six pillars bearing the weight of a slanting tiled roof. Leading off the living-room to the west is the dining-room, from which the service portion of the house stretches in a wing to the west, continuing the low, sweeping contour of the southern elevation.

Communicating through long glass doors on the south and east with the patio are the bedrooms, lighted also from the outside by long windows equipped with strong Spanish wrought iron grilles, these painted to accentuate the dark blue tone developed in the paving of terrace and loggia. The high silled windows are provided with stout wooden shutters painted that pale, beautiful green found on old bronze long exposed to the weather.

On the north facade, a wall, the height of the whole structure, connects the vestibule and guest room wing on the east. This is a crenelated wall, with tile coping, and serves to cut off the bitter north wind, making the patio a cosy center of warm sunshine, and preserves the symmetry and graceful proportions of the composition. The dominating impression achieved by Mr. Hobart in this attractive villa is one of dignity, comfort and charming simplicity.

Of sharply contrasting character is the quaint New England cottage Mr. Hobart has designed for Mrs. Charles Reynolds, to be built on the State Highway at Palo Alto, and to serve as a wayside tea house and exhibition kitchen

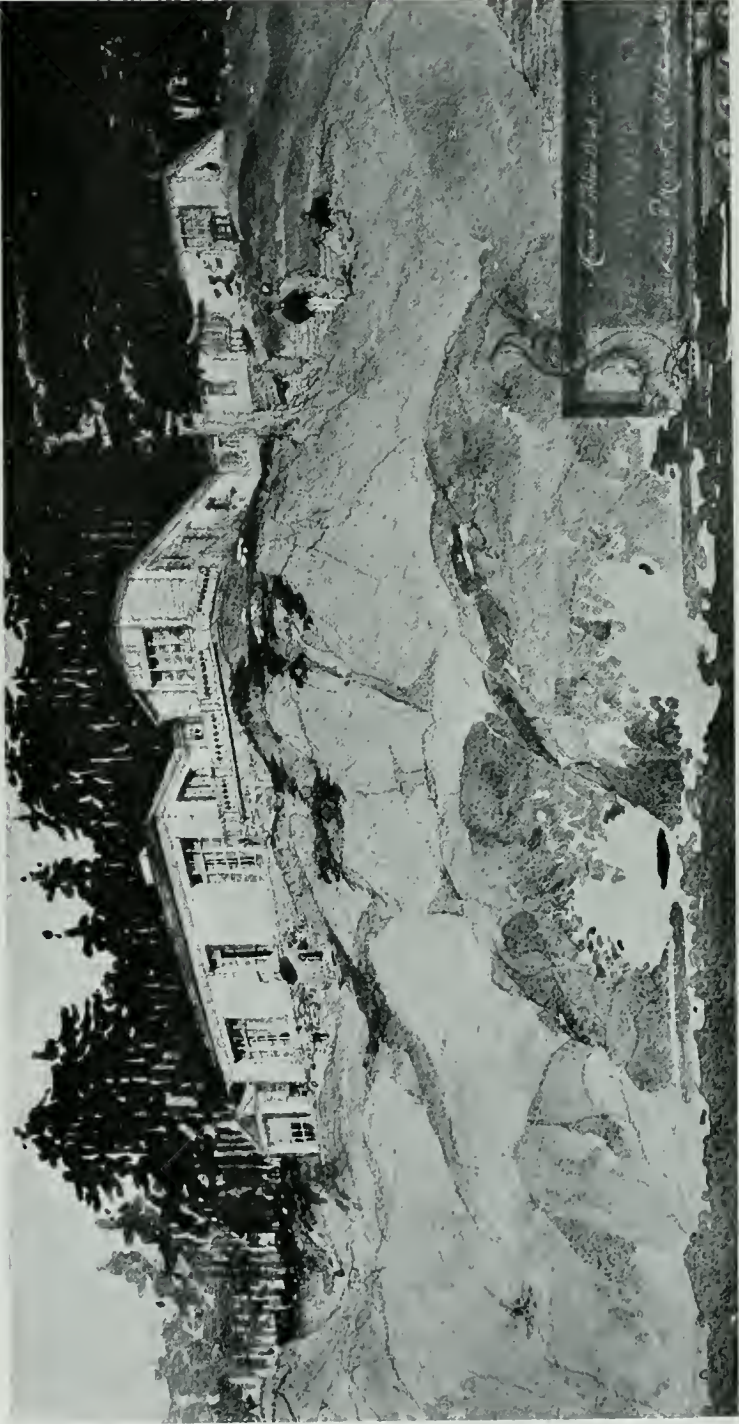

HOUSE AT PEBBLE BEACH, CALIFORNIA
LEWIS P. HOBART, ARCHITECT

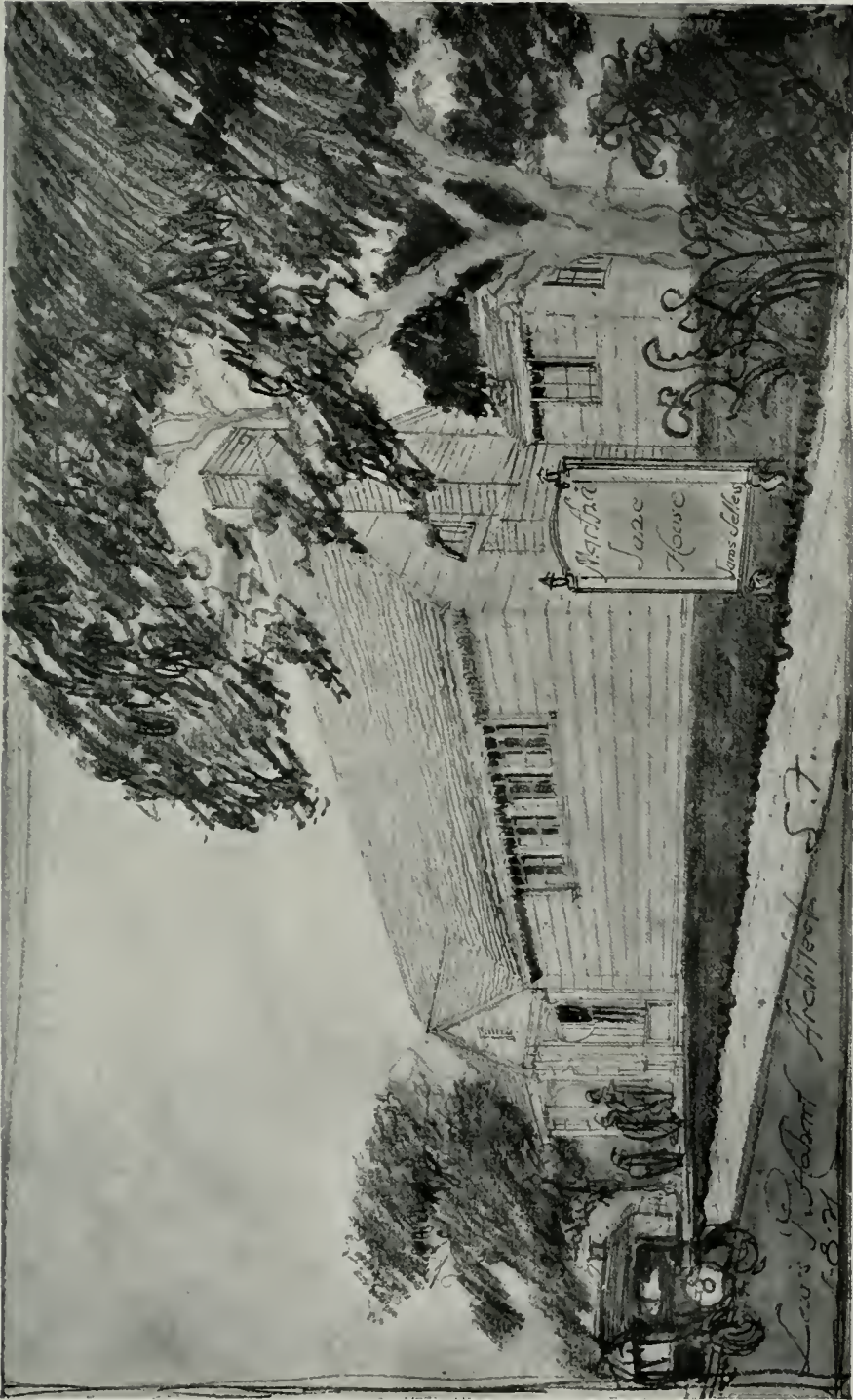

MARTHA JANE HOUSE. LEWIS P. HOBART, ARCHITECT

Lewis P. Hobart Architect S.F. 1884



HOUSE AT PEBBLE BEACH, CALIFORNIA
Lewis P. Hobart, Architect

for the manufacture of those jams and jellies already so famous as "Martha Jane."

This neat white cottage, its green shingled roof, and great, roomy, red brick chimney, breathe an atmosphere of homely Puritan comfort, of brass kettle and iron crane, rush-bottom chairs, round rag rugs, and quaintly painted, pink door-knobs. The entrance opens on the tiny porch so popular with the builders among the Pilgrim Fathers, and the windows are placed under the eaves, high above the ground, which, in New England, for long months, is banked with

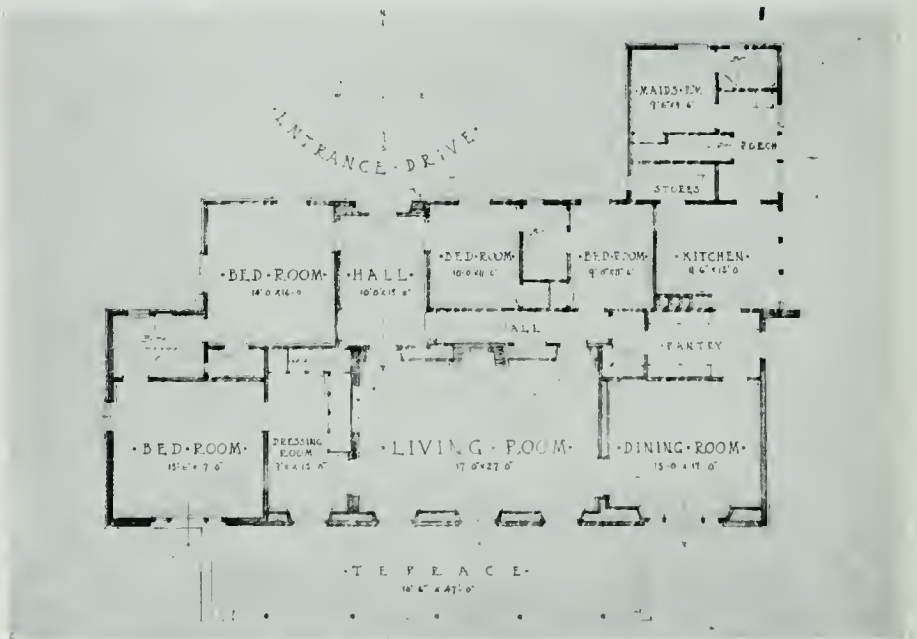

HOUSE AT PEBBLE BEACH, CALIFORNIA
Lewis P. Hobart, Architect



HOUSE FOR MRS. MILDRED CRAVENS, PEBBLE BEACH, CALIFORNIA
Lewis P. Hobart, Architect

snow. This would seem an unnecessary precaution in sunny California, but the intention is to utilize the space below the windows for cupboards stocked with "Martha Jane" products.

The motorist, dusty and tired, will hail with relief the sight of this cosy homestead and its smoking chimney, promise of the warm welcome within, where an open trussed timber roof, and hospitable brick fireplace add the final touch of piquant charm.

The charming and varied drawings showing Mr. Hobart's work are from the hand of Mr. Thomas J. Kent.

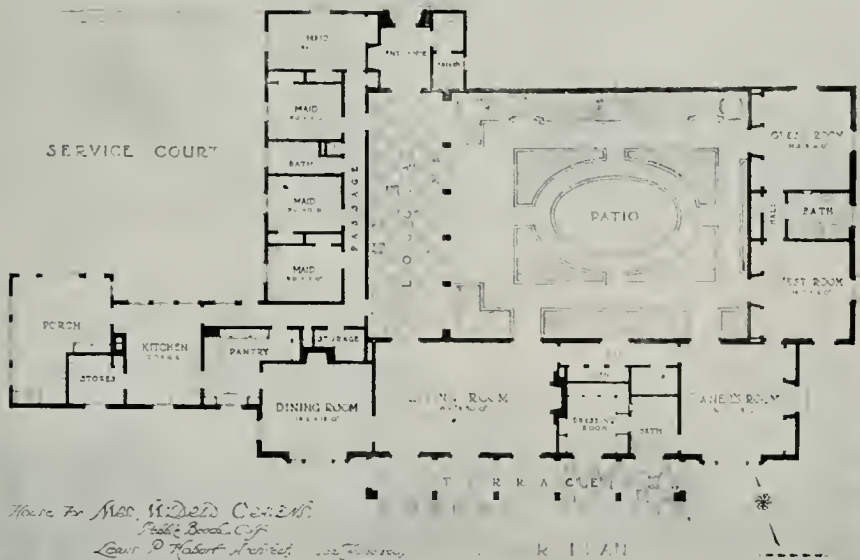

HOUSE FOR MRS. MILDRED CRAVENS, PEBBLE BEACH
Lewis P. Hobart, Architect (See next page)



HOUSE FOR MRS. MILDRED CRAVENS, PEBBLE BEACH



HOUSE FOR MRS. MILDRED CRAVENS, PEBBLE BEACH
Lewis P. Hobart, Architect (See preceding page)



HOUSE AT PEBBLE BEACH
Lewis P. Hobart, Architect

Latter Day Saints Hospital, Idaho Falls, Idaho

By H. NEWTON THORNTON, Architect

ONE OF the notable features of architectural practice in recent years has been the rapid development of hospital planning. The careful attention given by the architect to this branch of work has formed a striking instance of our progressive civilization.

A well planned and equipped hospital of today affords such immense advantages to the patient for his rapid recovery over the out-of-date methods and disadvantages of home nursing, that it is now becoming customary to go to the hospital even for minor ailments.

Some of the reasons for this attitude on the part of the public are the great advance in surgery, the good lighting for operations, making for greater safety; the expert service and the developments of nursing, all of which have been factors in the steady growth of hospital construction.

The Latter Day Saints Hospital at Idaho Falls, now in course of erection at an approximate cost of \$500,000, is one of the several new hospital buildings contemplated by the Latter Day Saints Church, commonly called "Mormon" Church, whose headquarters are Salt Lake City, Utah.

The Idaho Falls Hospital is situated on rising ground in a beautiful section of the city on the banks of the Snake river. The plan of the building has been given careful consideration both as to future extension and arrangements, and is in conformity with the most recent developments in hospital design. The general plan is T shape, with the administrative department at the intersection of the T. In the planning of a large hospital the problem appears to hinge upon three departments: (1) The kitchen; (2) The administrative; (3) Operating suite.

The building is intended to contain 120 beds, most of which are in single rooms. The kitchen department, part of which goes up two stories, is situated on the basement floor and occupies, with the receiving room, refrigerators and ice machinery room, and kitchen stores, the whole of the rear wing basement, with an entrance direct at the rear of the wing.

The plans show two dumb waiters for the conveyance of food from the kitchen, which are sufficiently large to admit of large electric heated food trucks, so that all the dishing up of the patients' food will be done in the kitchen and conveyed directly to the patients' rooms.

Refrigerators are provided in the service rooms on each floor, and also electric warmers so that light refreshments may be served to patients direct when necessary or ordered.

The feeding of nurses and help will be by the cafeteria method, located in the basement, the counter being parallel with the main corridor and adjoining the kitchen as shown.

An X-ray department is located on this floor with transformer and developing rooms, and a large plate filing and display room for the general use of the hospital, and in addition X-ray apparatus is provided for operating room use in connection with the laboratory. Adjoining the X-ray department in the basement is the hydro-therapeutic department and rest room, and the Drug Stores and Pharmacy are also located in this section of the building.

It might be well to state that the preliminary plans for this hospital did not contemplate any basement, it being decided through collaboration with many hospital superintendents that it could be used to a better advantage to get at the plumbing pipes and mechanical equipment, and thus avoid awkward stoppages of pipes, and afford easy access for repairs, etc. However, the ground was of



L. D. S. HOSPITAL, IDAHO FALLS, IDAHO
H. NEWTON THORNTON, ARCHITECT

L. D. S. HOSPITAL, IDAHO FALLS, IDAHO
H. NEWTON THORNTON, ARCHITECT

such sandy formation, that it was necessary to extend the foundations down about 14 feet to get good bearing, and the elimination of any use of this extra depth would be expensive and therefore use was made of same.

The stairs and elevator occupy the intersection of the corridors on the south side and adjoining the elevator hall is the ambulance entrance. It was thought best to use the darkest space for the stairs, they being used the least, and would give the least annoyance to patients in this location, and would enable all the direct light to be used for revenue producing purpose.

At the center of the main front is a main hall for the public, reached through a vestibule, and the entire hall and vestibule is to be treated with marble wainscotings and trimmings.

A Superintendent's office communicates with the business office, and behind this are the doctors' locker rooms and internes quarters. Modern Doctors' Register system, master clock system and nurses' time recording apparatus are located in the business office, with telephone operators' department. The second, third and fourth floors are divided into private rooms, most of which are for single beds. There are two communicating baths, and one private bath to each floor. The fourth floor is to be used exclusively for maternity cases. A delivery room adjoins the service room, which is arranged to save duplication in fixtures.

The Nursery is placed at the rear of the center wing, so that noise from this room will not disturb the whole floor.

The fifth floor, which extends over the central portion of the building, contains the Operating Suite. There are four operating rooms, all facing north with special arranged natural and artificial lighting. One operating room will be used for special cases and Orthopedic work. The sterilizing and scrub rooms are conveniently and economically arranged between two operating rooms.

The laboratory, arranged for full equipment, including cases for specimens, is located on the fifth floor near the elevator, and will be equipped with a small dumb waiter to each floor for service without using the elevator or stairs.

The roof over the south wing is to be used as an open air pavilion for patients.

The foundations of the building to the first floor are concrete, and all outside walls brick construction, using a yellow or buff face brick, with cement and stone trimmings. The floors are reinforced concrete, using the T. C. S. pan construction or concrete joists, which admits space for pipes.

The cornice and brackets are of copper, and the exterior is plain in design, but pleasing and restful, the vertical lines of the window trim giving an effect of unity to the design.

The finished floors throughout are of mosaic tile, except many of the basement rooms, which are cement, and the halls are finished with Linotile, to form a cushion tread with little noise. The boarders of all rooms and halls are Diato, or other magnesite composition, including a large sanitary cove base extended up all walls. Partitions are of plaster block, except in rooms and departments, where the walls are to be tiled, which will be burnt hollow tile. All toilets, bath rooms, janitor rooms, service rooms, etc., are tiled four feet high.

The floors of the operating rooms are marble mosaic, and also the walls, to a height of six feet.

All stair work is magnesite composition, including landings.

The windows are double hung box frames, with transoms over the bottom rail of all sash sufficiently wide to receive Pullman or other suitable ventilators. Frames are wood with hardwood parting strips, and all sash are pine and

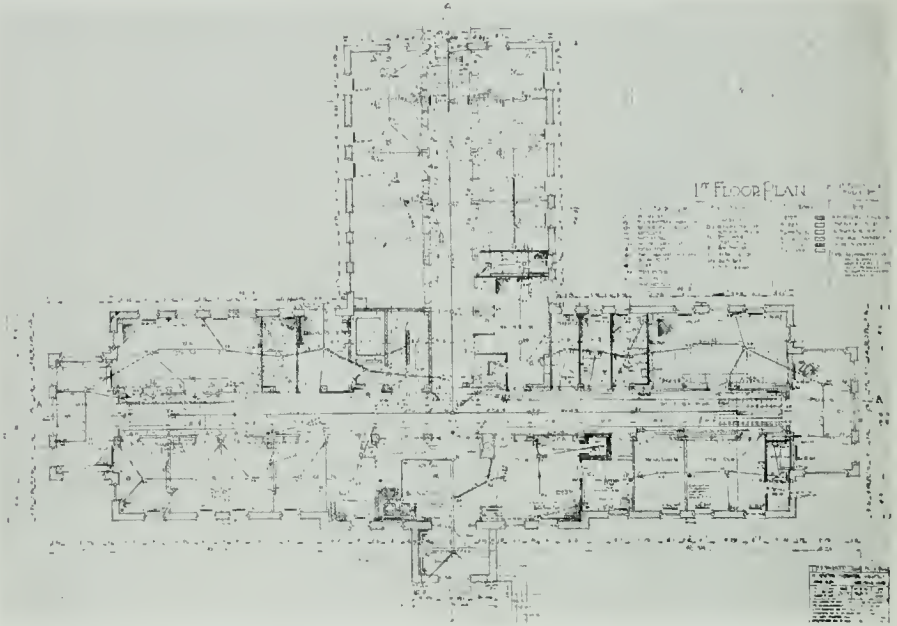

FIRST FLOOR PLAN, L. D. S. HOSPITAL, IDAHO FALLS, IDAHO
H. Newton Thornton, Architect

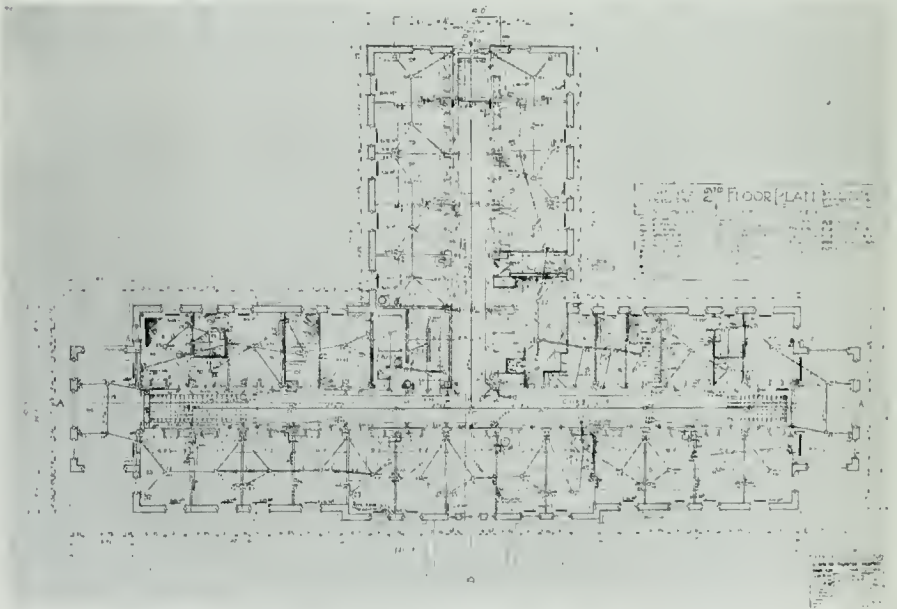

SECOND FLOOR PLAN, L. D. S. HOSPITAL, IDAHO FALLS, IDAHO
H. Newton Thornton, Architect

divided lights. Metal weather strips throughout. Kitchen and boiler house are steel sash.

With the exception of the entrance hall, which is panelled in mahogany, there is no wood trim in the building. All windows and doors and other openings are plastered reveals, and all plastering throughout is Keene cement smooth finish, to receive flat wall paint or enamel. All doors are slab type of hospital doors, mahogany veneered, and all corridor doors have inlaid veneered panel. All door frames are metal, flush with plaster work and plain design.

The heating is Dunham Vapor system throughout, and all radiators hung on walls, and all piping concealed. There will be a deep well driven on the site in pump room as shown, with electric power pump and also emergency gas engine, and also water softeners installed for laundry use. All water will be filtered for domestic use, and an ice water circulating system throughout for drinking purposes.

The design and construction of hospital buildings are very complex in their many vital problems to be solved, making it necessary to give close study to all working conditions, and collaboration with employees of such institutions is necessary in order that some of the errors in existing hospital work may be eliminated, and that all departments may be cooperative and economical in operation.

* * *

Praise for Architectural League's New York Exhibit

THE annual exhibitions of the Architectural League of New York have come to be one of the most interesting art events of the year, says a writer in Stone. It will be remembered that just as the exhibition was about to be opened last year it was swept by a disastrous fire that destroyed the hall and many of the exhibits. A month or two later the salvaged material was publicly shown, but it was pitifully inadequate. The league, however, pluckily set to work and declared that it would offer something better than ever this year. This pledge has been redeemed in the exhibition that has just been opened in the new wing of the Metropolitan Museum, generously placed at the disposal of the league by the Museum trustees. For the first time in its history the league has an adequate and satisfactory hall for the display of its treasures. The arrangement is effective and artistic, and the exhibit fulfills its purpose by an equal appeal to the layman and the architectural student. Much of the best of recent accomplishment in American architecture is shown in model, plan and photograph. In addition to this the kindred arts, sculpture, painting, stained glass, decoration, and landscape gardening have a strong showing. One very interesting feature is garden sculpture, which is steadily growing in importance in this country. Statues, fountains, sun dials, and the like, the creation of gifted and imaginative artists, show how much we have progressed in public taste and appreciation since the days when cast-iron monstrosities cluttered our lawns. Perhaps the most vital fact of the entire exhibition is that we have not only an architectural art fully equal to any in the world, to say the very least, but a generous public that appreciates and commissions this skill.

* * *

Good Reason

Bricklayer. "Us workmen haven't a chance—the contractor makes all the money."

Owner: "Why don't you go in for contracting?"

Bricklayer: "Can't; wages are too high, and the fellers don't work as they used to."

How Long Does an Office Building Last?

THE Government has raised the question of the longevity of the average fire-proof office building in order to get facts for a case pending before Income Tax authorities, which has resulted in an investigation and examination of the question by various building owners and managers. The following, from the Bulletin of the Building Managers' Association of Chicago, throws some interesting sidelights on the subject:

"No doubt, to the average person, a modern office building with its imposing and massive architecture is a structure built to last countless years which neither wear nor changing conditions can harm. Experience, however, shows this to be far from the fact, for even despite every effort to stay 'old age' through repairs and rejuvenation, the inevitable element of obsolescence develops and cannot be overcome. Not always a pronounced physical deterioration, this condition is usually best explained by the term 'old style.' 'Antique' is suggestive of increased values when applied to certain art objects. It means just the opposite when applied to office buildings. Nor need a building necessarily be old in years to be so regarded, for changing styles in architecture and continuous improvement in the physical features of newer buildings soon detract from the so-called modernity of buildings of earlier construction. Then too, changing city conditions reflected often-times in greatly increased ground values and consequent high taxes may necessitate a standard of rentals unobtainable for the particular building in competition with more modern structures, thus making it an inadequate improvement for the lot. A change in neighborhood conditions may also shorten the profitable life of a building well-planned, and which when constructed was considered in the judgment of its builder to be a permanent investment. Or again, increased ground values may become so great as to make it necessary to build higher buildings than have yet been constructed.

"Obsolescence, therefore, is a vital factor in the probable life of the average modern fire-proof office building despite the fact that occasionally there may be found a building where age seems not to have affected its prestige and renting possibilities. Usually, in such cases, however, there will be present some special reason why the investment continues profitable despite the age or obsolete type of the building. Such cases cannot be used in a fair consideration of the general question.

"What has happened in downtown Chicago in the past 35 years tells its own story of how 'permanent' modern office buildings are with the passing of time. Look at this list of almost forgotten names of prominent office buildings which were removed (with two exceptions) after lives of less than 30 years to make way for another crop of more 'modern-permanent' buildings:

"Champlain Building, 15 stories, northwest corner Madison and State Sts. Erected 1894. Demolished 1915 (21 years).

"Continental Bank Building, 10 stories, LaSalle and Adams Sts. Erected 1884. Demolished 1912 (28 years).

"Rand-McNally Building, 10 stories, Adams St. near LaSalle St. Erected 1884. Demolished 1912 (28 years).

"Trude Building, 14 stories, southwest corner Wabash Ave. and Randolph St. Erected 1897. Demolished 1912 (15 years).

"Royal Insurance Building, 15 stories, 160 W. Jackson Blvd. Erected 1885. Demolished 1920 (35 years).

"Montauk Building, 9 stories, Monroe St. near Dearborn St. Erected 1883. Demolished 1902 (19 years).

"Mallers Building, 12 stories, southwest corner Quincy and LaSalle Sts. Erected 1886. Demolished May 1, 1920 (34 years).

"Six directors prepared individual opinions, the consensus of which was that 'it is not safe from an investment standpoint to assume that the profitable life of even the best fire-proof office building in Chicago will exceed from 30 to 40 years from the date of its construction.'"

* * *

Bottled Courage

"Is this stuff guaranteed to make a rabbit slap a bulldog in the face?"

"My dear sir," said the bootlegger, with a pained expression, "this stuff will make a tenant snap his fingers under his landlord's nose."

"I'll take two quarts."—Birmingham Age-Herald.

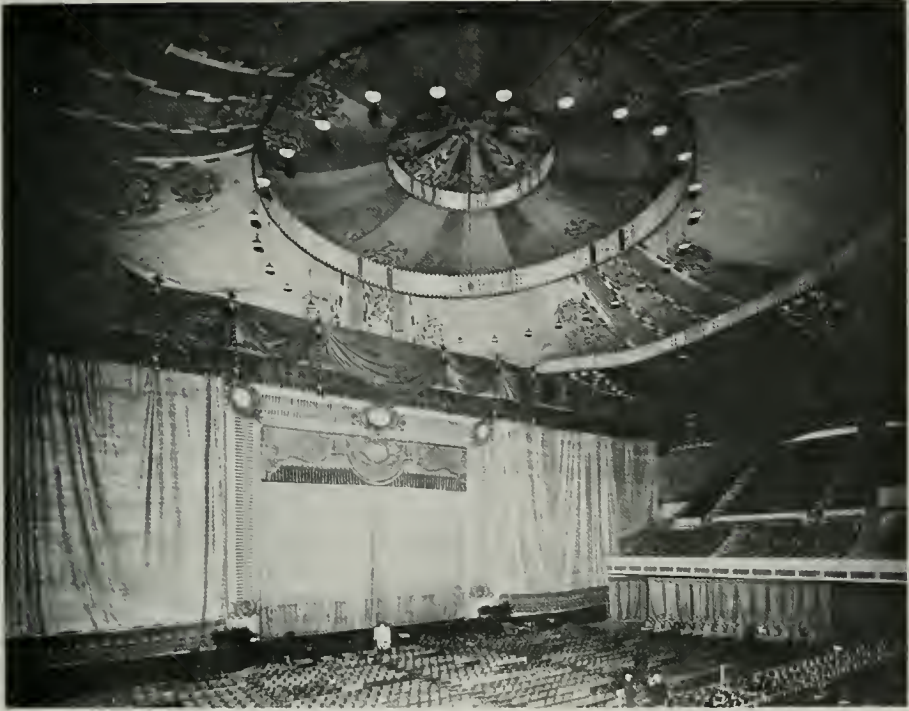

MUNICIPAL AUDITORIUM, SAN FRANCISCO, AS ARRANGED FOR THE GRAND OPERA SEASON BY G. A. LANSBURGH, ARCHITECT

San Francisco Auditorium as an Opera House

THE following complimentary notice was paid by the San Francisco Bulletin's opera critic to Mr. G. Albert Lansburgh, who planned the re-arrangement of the Municipal Auditorium for the recent grand opera:

"The audience at the opening performance of the opera season would have filled and flowed far out of the biggest theater in the country. But in the Auditorium it left some waste spaces, mainly in the upper regions. Before the place was darkened some admiration was expressed for the artistic way a hard situation had been dealt with in the effort to improvise something that should look like an opera house. The colors used in the heavy stuffs that served for curtains and for cutting off the great platform were exceedingly well chosen. Much of the material on the ceiling prepared for the Democratic Convention last summer was made to serve again and it served well. I've been told that credit belongs to the San Francisco architect, Albert Lansburgh. He deserves to be especially complimented for the rich beauty of those peacock blue curtains."

* * *

The available water power of the State of California is 9,250,000 horse power and is exceeded only by that of the State of Washington with 9,500,000 horse power.



BAY CITY MARKET, SAN FRANCISCO
Smith O'Brien, Architect

Oxy-Acetylene Used in Breaking Up Concrete

IN A building under construction in Cleveland, Ohio, considerable concrete work was put in through an architect's error. It was found necessary to remove the misplaced structure, and a crew of laborers assigned to the task attacked the concrete with sledges and drills. At the end of three days the progress made was so small that other and more rapid means of removal became imperative.

In the emergency a practical gas welder was called in to determine what could be done with the oxy-acetylene torch. A demonstration proved the feasibility of speeding up the work with the torch and the job was thereafter turned over to a local welding firm.

The method employed consisted of heating along the line of the desired fracture with an ordinary welding torch, using a long bushy flame. The concrete was not raised to a great heat, as measured in terms of oxy-acetylene, but the heat was confined as much as possible along the proposed line of fracture. When so heated the concrete yielded to a heavy blow of the sledge, breaking off in the predetermined form and bulk.

This is not a new application of the oxy-acetylene torch, but, as it is a bit outside of its ordinary field, which is essentially the welding and cutting of metals, it is well to keep it in mind for emergency cases of the type noted. There are doubtless many other places where the torch might be advantageously applied in wrecking concrete, especially when for any reason the use of chipping or drilling is impracticable.

The Architect's Service to the Community and His Opportunity to Make Better Cities

By ROBERT D. KOHN*

I feel like apologizing, as I did elsewhere, for the fact that I come from New York. New York, after all has the reputation throughout the country of being a little isolated place down there that knows nothing outside Manhattan Island. Yes, it is nothing but the Los Angeles of the Atlantic coast. I happened to have been born there. I met a man here today who said he was born in Los Angeles. I know five other men in New York that were born there. The rest of the population came from Kansas City and Seattle and San Francisco, and there may be a few from this city. There are very few that come from there. Here is a man in front of me who says he was born there. That makes six I know.

Everybody has been talking about New York City, but I am going to slam my city to begin with. We have too many people in our city and we don't know what to do with them. We wish we wouldn't have any more. We wish that no more would come there and that some that we have now would go away. The enormous size of that city simply aggravates the problems that other cities have. It is a wonderful place to study those problems. I don't know what is going to happen to our city. We have got to go out and see the rest of the world and get a breath of fresh air. I am reminded of something a friend of mine—a newspaper woman—said some time ago. She had been up in Washington state and she said, "Oh, it does me good to get up there. I didn't realize until I came back and rode up town in the subway what a terrible place New York is." I said, "Why did you come back?" She said, "I can't stay away. More things happen here in ten minutes than happen in the rest of the world in a year."

It is the place to study these very problems the whole world wants to know about and has to study. You can avoid those things if you start early enough—can avoid a lot of things that we are up against. Our housing problem is terrible. You know about that. Four or five families living in one room. The city is growing too fast. No houses being built at all. I think we need thirty thousand apartments a year to keep up the record and there haven't been five hundred built on an average for the last four years. This means new slums. That kind of rottenness breeds another kind of rottenness. Don't believe from what you read that any one part of the industry is more rotten than the other. Don't think that it is the workers' fault, or the contractors' fault, or the architects' fault. They say that it is the architects' fault too.

The situation is one which gives the architect the opportunity to cover that whole field and to bring his knowledge that he has gained by studying these various fields to influence the lives of people in his own city. The city development problem is the architect's problem. He has a great chance of serving the community because of what he knows of that problem of growth, of catching the city early before it gets too far. Every one of our cities in a small way is doing the same things New York did. They want to be big. They want to grow—without looking ahead to see what they are making.

It does us no good to make subways. It does us no good to make traffic laws. The condition has changed before they are completed. At Christmas time this year you couldn't go up Fifth avenue in an hour in an automobile.

*Director of the American Institute of Architects. An address delivered before Southern California Chapter, American Institute of Architects, at Los Angeles, February 15, 1921.

I could walk up quicker. We have hanged ourselves with the idea of a big city developing before we have laid the foundation.

The architect can do much to prevent such a condition. He knows what the problem is. He has the training for putting things together in such a way that they will work, and that is what the cities need more than anything else—to be put together so that they will work—and I can speak with authority, knowing that our own city does not work.

Architects' Service to Community.—Now permit me to point out what the Institute is trying to do. Its sense of service to the community is very highly developed. As we have gone around I am sure Mr. Kendall has been very greatly impressed with the character of the people we have met, and I have. It is certainly a fine type of men who somehow go into the architectural profession—the spirit with which they attack their problems—the ideals that move them. For instance, that Minnesota small house problem, that fine move to furnish the poor man with a properly planned home, is only one indication.

In Buffalo the architects have got together on the school houses in the city of Buffalo—not to compete with each other—and they jointly plan all school houses for the city at a very modest cost. Their plan is not to parcel out the work, but each architect can contribute to the general scheme the thing he knows best. It is working very well at the present time. I think they have thirty-five or forty school houses in charge. The fine thing about it is not only that they are producing for the city an admirable set of school houses at the lowest cost possible, but through the getting together and working together they are learning to know each other better.

The best thing I have heard about that was this: There was a good deal of discussion about who was to build the school houses, and they said, "We will get together and offer to do the work jointly." This was a group of about a dozen men. When that was published about a dozen other architects came up and raised a row and said they wouldn't have it, and so the second dozen was added to the first, and there were twenty-four of them co-operating. When that was about to go through six or eight more came along, so they had to take them in, and so finally there were thirty-two of them. And the man who was telling me about it said they were very much puzzled as to how they were coming out. Some of the men they had to take in they did not consider very competent, and they rather suspected the motives of others. "But," he said, "a wonderful thing has happened. Under our plan we have discovered that every one of them had something worth while to contribute to the whole, and we have got to know these men, and some of these fellows that we thought were yellow dogs we are convinced are fine fellows, and we know every one of the architects in Buffalo and they are all working for the city in a fine spirit." So out of that co-operation has come not only school buildings, but an intimate knowledge on the part of the profession and in the right spirit they have been working together.

Architects Making Better Cities.—That is true elsewhere. These co-operative groups are being formed. We find architects working on zoning laws and districting for the city. I wish I had time to tell you about what New York has done on the zoning laws. We have absolutely tied up the city so that you can't put a business building in this district, or a factory in that one. The city is completely zoned and districted and heights of buildings restricted. We are not only getting a better city and stabilizing property values, but we are getting a better looking city. We considered that while we were working on the law, but we didn't let them suspect it. We said it was to protect property values and stabilize the business districts and prevent a man putting up a factory right next to a fine row of dwellings.

But we are getting a fine looking city out of it. The law permits a building to go to a certain height in proportion to the width of the street—twice the width of the street. If the building is set back from the street you can go up higher—twenty feet back you can go up sixty feet higher. It is producing tower buildings all over the city.

I find St. Louis has a law of that kind. Portland is working on one. A number of cities in the west and middle west have laws under way or adopted. I find everywhere the architects working for that. That is a thing he can do.

In the past the architect has been an individual all off by himself. He has got to realize himself in terms of service. He has got to get more power to put his ideas into effect. We are very weak when we come before city officials. I don't know anything about Los Angeles. I have seen your Mayor and I know you have a good one. We have a very bad one. I was careless enough in Chicago to say something I was sorry for. I got up and claimed that we had the worst mayor in the United States. A Chicago man got up and called me a liar.

Technical Men in Government.—We have had good city administrations in New York but unfortunately I fear we haven't one now. We have had administrations that recognized the trained technical man as being important in government. Our present mayor is a remarkable man in some ways. He doesn't believe in experts.

On one occasion they were going to appoint a man to a very important technical office in the city administration, the chief of the Bureau of Fire Prevention. He has administrative control over all the factories. We appointed a committee to call on the mayor. We said, "Mr. Mayor, it is very important that this man be an engineer or fire protection expert or someone with thorough knowledge of factory buildings." The mayor said, "Do you mean you want me to appoint an expert to this office?" He said, "I don't want any experts around. The common man is good enough for me." He appointed for the head of the Fire Prevention Bureau of the city of New York a veterinary, a man who had had charge of the horses of the fire department. When they did away with the fire horses he had nothing to do. I had occasion to go down to confer with him and he said, "I don't know anything about this. Why bother me about it. Go to someone who knows about it."

The most important thing in the government of America today is its need, in the cities and in the states and in the nation, of the technical knowledge of the trained minds of the country. During the war men started in volunteering their services to the national government, the biggest business and technical men offered their special knowledge to the government. Now if we could only preserve some of that spirit of war time service for the good of our cities and our states, we would be so much better off in government. But there is always that suspicion that it is a private interest—that they are trying to work something on the city government or the state government.

All of you have had that experience of going up to your state legislature. I don't know about your state. I will talk about my own state. I remember one instance not so long since when a committee of architects went to Albany to argue about building matters, and at the same time that we appeared a committee of physicians was there to argue about a bill for checking the investigation work they were doing. The two groups sat there talking investigation work that was being done. The two groups sat there talking to a committee, not one man of which had the faintest knowledge of medical

science or any knowledge at all about building, and we had to argue on technical subjects before them.

I always like to tell of an occasion when a committee of architects and engineers met before a committee of seven men, one of whom was a grocer, one a butcher, one a salesman, one a walking delegate from the steam fitters union (that was the nearest thing to a technical man on the committee), one kept a stationery store and one was down on the list as not having any business. We didn't know how he earned his living. There was that committee of six or seven men listening to these complex things that I didn't understand, and passing on them, God knows how.

Must Organize Trained Minds.—Now we have got to organize the trained minds of the country, the business men who have a great fund of knowledge as business men, as to business and certain kinds of materials, and the technical men. We have got to organize so that their knowledge is at the service of the government and each community and each state. It is the greatest thing that can happen. We must get in normal life that spirit of service which was shown during the war.

That is one of the greatest things the Institute is doing today. We get together in every State. We have the knowledge—we have it through our training, through our experience. We must put it before the community. We must impress them with the fact that we are not seeking to further our own private ends. We can do it if we do it jointly. We can't do it as an individual, but a group of men jointly offering their services, saying, "We know about these things. We know how this city can be planned to avoid these things. We can save you from that."

Join with other technical men. Join with the business man. It isn't only the professional men. In one of our middle western cities not long ago I was talking to a man about a scandal that had appeared in the papers that day regarding the quality of the things furnished the people in the poor house and the hospital. I asked him why this had happened. He said, "The man who was in charge of the purchasing didn't know anything about what he was buying." I asked him if he didn't think that if the grocers and butchers were organized and made to realize the conditions, if they were asked to render the city a service through their organization, to guard the city institutions against that sort of thing, if they would not use their knowledge and experience to do it. They all said they would without doubt.

That is what I mean when I say that the professional men must lead the way. They must show how it must be done. In each community, jointly, not each individual trying to do a little share, but as a whole body put before our cities and our state that great treasure—that great artistic treasure and that great technical treasure which has been handed down to us from the past. We are heirs of the past. We haven't made this knowledge. We have had it handed down to us from the ages past. We must put it to the service of our nation and our state.

* * *

The Man With the Paint Brush

The man with the paint brush can do more to add value to a piece of property at less expense than almost any other craftsman. That is because he can make an old surface look new and clean. He hinders decay and inspires a "look-see" into corners and dark places. The successful contractor loses no opportunity to show what the man with the paint brush can do to increase property value.—National Builder.

Metal Lath for Stucco Houses

By ZENAS W. CARTER

Commissioner, Associated Metal Lath Manufacturers

THE use of metal lath and stucco continues to grow in popularity and it is not uncommon to find entire blocks of cement houses in our large cities. Stucco houses are not difficult to design and build, and they have a substantial appearance which appeals to the prospective buyer.

The adaptability of metal lath to any style of architectural design in construction; its fire-resistive qualities; a perfect sanitation which is secured through the use of stucco exterior combined with metal lath reinforced cement floors; fireproof roof coverings and solid partitions, make a combination which is a close competition in cost to inflammable construction and which is much less expensive than other fire-resistive types.

The availability of lime and cement, gravel and sand, as well as metal lath, in practically all sections of the United States, and the difficulty of transportation for materials of other kinds, have also been determining factors in causing architects, engineers and contractors to use stucco for warehouse and private housing development work.

While few new methods of utilizing cement, patent stuccos and plasters and metal lath have been brought out during the past year, there are a number of points which have been checked up more carefully than heretofore and on which it is important that all have information.

For one thing, there has been in the past considerable controversy over the use or elimination of wood sheathing when stucco on metal lath is applied to wood stud construction. The investigations made by various independent groups, as well as by the Associated Metal Lath Manufacturers, have clearly shown that the use of metal lath applied direct to wood studs without sheathing has been extensively and successfully adopted in residence construction throughout the New England States during the past fifteen years, and that this method has always proven satisfactory in every way. If a building is located where wind stress may be considerable, a double cross bracing between studs may be used; but in New England it is common practice to use only one cross brace between studs on each floor.

The reports from owners and architects in the Eastern territory have shown that houses constructed in this way are amply insulated from both heat and cold, being cool in summer and requiring a minimum amount of fuel for heating in winter. It is also a fact that these houses never show dampness from condensation on the inside, and when plastered on the inside with metal lath and plaster there is practically no cracking, either exterior or interior, and thus re-decorating costs are reduced to a minimum, while it is, of course, not necessary to paint stucco in order to get an attractive effect, or to preserve it.

In fact, in the development of the Russell Sage Foundation residences at Forest Hills, L. I., the architects and engineers found that the slight initial cost for metal lath over other material was more than offset in a ten to twelve-year period by the saving in re-decorating and re-plastering, with the result that although largely stone and brick exteriors, every one of the hundreds of homes in this Forest Hills grouping have only metal lath and plaster partitions, ceilings and inner walls, and this Forest Hills development, where only beautiful and high-class homes can be erected, is undoubtedly the most beautiful and architecturally ideal home building community settlement in the United States, if not in the world.

In the application of metal lath, either exterior or interior, only long staples (not less than one-half inch No. 14 gauge) should be used and these should be placed not over six inches apart, as the recent tests made at the Underwriters Laboratories at Chicago showed clearly that long staples would hold lath in place for a much longer period than the one or one and one-fourth inch staples frequently used. Particularly is this true in ceiling construction. These tests at the Underwriters' Laboratories showed that metal lath and hard wall plaster panels erected on standard 2x4 studs, placed sixteen inches on centers, would stand up perfectly under the forty-five minute fire and water test; and on the second panel test these materials withstood fire ranging from 1200 to 2000 degrees Fahrenheit for three hours one and one-half minutes.

In applying metal lath to wood studs for stucco exterior, it is best to use lath weighing not less than 3.4 pounds per square yard and this weight lath should be placed on studs spaced sixteen inches on centers. Lighter weight laths do not offer as rigid a type of construction for exterior work unless spacing of studs is changed. For interior construction the standard material weighing 2.5 pounds per square yard may be used on sixteen inch stud spacing to good advantage.

The first sheet should be applied at the top of the wall for exterior construction, or at the juncture of the ceiling and side walls and should extend at least six inches each way to prevent cracks appearing at the angle. On the ceiling and side walls the edge of the last sheet applied should overlap the preceding sheet about one-half inch and the edges should be wired at least once between all studs or joists to prevent the edges from separating when the plaster is applied. The sheet should be lapped around vertical corners at least one stud, with staggered end laps.

For interior wall and partition construction the two-inch solid metal lath and plaster partition has become extremely popular. The two-inch partition is sound-proof, proof against rats or vermin, and saves at least three inches of space per running foot in the interior of the room.

In stucco construction it is now deemed essential that the walls be back-plastered if no sheathing is used. This imbeds the lath in a concrete slab which forms the side wall and absolutely preserves the unit for an indefinite period.

Houses erected by Architect Frederick G. Sauer, in Pittsburgh, in 1891 and 1892, where the lath was imbedded in the stucco, have shown practically no checking or cracking; have never had to be painted or repaired in any way; and Mr. Sauer states that in making some recent changes on one of these buildings he found the lath to be in the same perfect condition as originally used twenty-seven years ago. His experience there has definitely exploded the theory that Pittsburgh smoke conditions are detrimental to metal lath—although it should be noted that the essential feature of this construction was the complete imbedding of the lath, the same as is now secured by back-plastering.

When sheathing is eliminated, it is easily possible to place a film of roofing paper or tarred building paper on the inside before plastering the interior if the architect or owner have any doubt in their minds regarding the heat and moisture insulation offered by the four-inch wall of back-plastered stucco.

In stucco houses or building construction of any kind, the contractor needs to be cautioned about the necessity for flashing at the eaves. Stucco houses should always be given the benefit of a wide overhanging protection where possible and when this style of architecture is used the copper flashing over the eaves will prevent the moisture from moving up into the concrete through capillary action and thus attacking the lath.

In solid composition or concrete floor construction, metal lath is used as a reinforcing material to prevent cracking. Only lightweight lath is necessary for this work.

Another recent use in connection with hollow tile wall construction has been suggested and used by Mr. Robert D. Kohn, architect of New York City. This is to cut the sheets of metal lath into strips the width of hollow tile and use these strips laid full width of wall between the rows of hollow tile blocks, securely tying the wall together and thus causing uniform action of stresses and preventing uneven settlement and unsightly cracks in stucco on hollow tile or walls. This also saves considerable waste of mortar, which would otherwise drop into the tile and it speeds the masons buttering-up to a considerable degree. In some recent tile construction of this character in Peekskill, New York, the contractor actually saved money in adding these metal lath strips, the saving in mortar and time much more than offsetting the slight cost for the metal lath strips.

* * *

Terrazzo Floor Chips

THE following specification for terrazzo flooring is furnished Rock Products by Starret & Van Vleck, a prominent firm of New York City architects:

The marble chips used shall be as selected by architects, from samples to be submitted, and shall be of such size as will pass through a $\frac{5}{8}$ -in. mesh and be retained on a $\frac{3}{8}$ -in. mesh.

The mortar shall be composed of one part of approved portland cement to two parts of clean white sand.

The fill will be brought to within approximately 1 in. of the finish floor under another division of the work.

Immediately after the fill has been placed and before same has set, spread a bed of mortar containing as large a percentage of marble chips as possible.

Screed to a level surface and sprinkle over the top with enough seeding chips to allow as large a percentage as possible to show on the surface. Roll in the chips and when set rub with an approved machine to a smooth, durable surface.

Wash clean and finish with a coat of oil.

Lay the floors in sections, with joints extending through the layer of terrazzo.

The part of this of most interest to rock products producers is, of course, the specification for the chips. Nearly all specifications for terrazzo are based on experience with Italian marbles. American marbles and crystalline limestones, however, are gaining rapidly in favor and in many cases need merely to be shown to be accepted.

Some terrazzo floors are composed wholly of white chips, but the more common have various colored chips. The preparation of these chips is chiefly a screening proposition and any of the vibrating screens on the market are satisfactory for this purpose.

* * *

Bethlehem Steel and Labor

The action of the Bethlehem Steel Company in refusing to sell structural steel to contractors who operate closed shops is not understood by the public. Of course, the steel company has no liking for the closed shop idea, but would not carry its objection to a point where it would lose profitable sales. Experience has demonstrated that selling structural steel to contractors or erectors of steel buildings does not pay if the building operations are held up by strikes. The steel company has suffered severe losses through the inability of the erectors to pay for the material sent them. The recent action of the Bethlehem Steel Company appears to be more a credit matter than an attempt to persecute union labor.—Shoe and Leather Reporter.

Why Banks Stopped Construction Loans

THE construction industry has been worried about the transportation situation, but the minute that the banks were unwilling to float loans, building activities stopped and railroad conditions and coal became only incidental.

The banks were obliged to stop construction loans, not because of prices of materials, but because they could not dispose of the real estate mortgages to their customers. This was largely due to the Federal Income Tax which, with its heavy Surtax on the larger incomes, makes mortgage buying at 6% absolutely impossible. Exactly how this works against the larger incomes—the source of most of the investment money—is apparent.

The present agitation to make mortgages on homes exempt from Federal Tax should, therefore, be thoroughly understood by those who are in the building business, and who are now powerless to aid in the housing shortage, because loans are not available.

No one factor is as vital to the safety of the whole country as the building of homes, and it is, therefore, the privilege as well as the duty of everyone connected with the building industry who understands this situation and whose very livelihood depends upon construction activity, to advocate legislation which will release vast sums for home-building.

The Government—that means the people—have within their reach a very powerful force to attract sufficient capital to the construction of homes if it is only called into play. To encourage American manufacture, a tariff was imposed, and to increase farm loans and municipal improvements, exemption from Federal Income Tax was inaugurated.

No one can blame the man with an annual income of \$50,000 for refusing to make investments that will yield but \$412 on \$10,000 when he can get \$600. It is good business for rich man or poor, to make the investment that looks most profitable, so a unified appeal to every member in Congress for the tax exemption of mortgages, is now the only logical solution.

The bulk of new money for mortgages must come from estates and individuals having such excess funds as are not available until incomes of \$520,000 or over are reached. As an example, an income of \$30,000 is subject to a Federal normal and surtax, totaling 21% in addition to the income taxes levied by several of the States. This income tax must be deducted from the gross return on the mortgage before the net return to the investor is found.

To compete with the 6% Municipal Bond which is exempt from income tax, the banks cannot offer a \$30,000 investor anything less than 7.6% on a taxable mortgage, or to the \$50,000 investor anything less than 8.7% and have him come out even. With mortgages tax exempt, however, they could readily be sold at a 5% to 6% basis.

Already the State of New York has removed the State Income Tax from mortgages up to \$40,000. It is up to Congress to remove the Federal Income Tax. All people must understand the situation, because Congress responds only to popular demand.

The building industry is at a stalemate. If new money is not provided by investors, the housing shortage will continue at its alarming rate, and in less than five years there will be 130 families to every 100 houses in the United States. What conditions will be under those circumstances, can be best pictured by the Health Departments of the large cities that are already worrying over the rapidly spreading slum districts where the number of families obliged to live in one house is spreading disease and dissatisfaction throughout the community. —The Concrete Age.

Department of Safety

Conducted in the Interests of the Building
Public and with the Co-operation of the
California Industrial Accident Commission

Another Hatchway Door Fatality

By ED. F. OWENS, Elevator Inspector

On the morning of September 8, 1920, the writer was called to investigate a fatal accident on the passenger and freight elevator in the rear of Roos Bros. store at Stockton and Market streets, San Francisco.

Mr. Friedburg, the deceased, had been employed as a nightwatchman, and it was his custom to use the elevator when making his rounds to the different floors.

The elevator is a shipper rope control type and is equipped with a shipper rope lock. The object for which the shipper rope lock is installed is to lock the operating rope in the "stopped position" while the elevator is being loaded and unloaded and should not be used to halt the travel of the elevator. However, it appears that Mr. Friedburg had the habit of applying the shipper rope lock to stop the elevator when it was approaching the floor and before the elevator had stopped he would open the door and step onto the floor.

At the time of the accident he had apparently forgotten to apply the shipper rope lock and while the elevator was approaching the first floor he opened the door and stepped off the elevator onto the floor. He slipped and fell on his back, his head and shoulder protruding into the shaft. Before he had time to pull himself onto the floor the top of the elevator car caught and crushed him against the first floor landing threshold. The body was wedged so tightly that one of the guide shoes on the car broke the maple guide and stopped the elevator.

The fire department was called and the floor had to be cut away before the body could be removed.

The practice of using the shipper rope lock to stop the elevator at intermediate landings is wrong for it can not be relied upon to stop the elevator at all times. It also causes unnecessary wear and breaks the wires in the operating rope, giving the exposed ends a chance to stick out and possibly lacerate the hands of anyone who may operate the elevator.

Immense False-Work Carries Concrete Trusses

By J. J. ROSEDALE, Construction Engineer

ENGINEERS, architects and builders in Southern California are watching with considerable interest the construction of Grauman's Metropolitan Theater.

Early in July, 1920, excavation was started for the foundation, and rapid progress is being made so as to complete this structure in the fall of 1921.

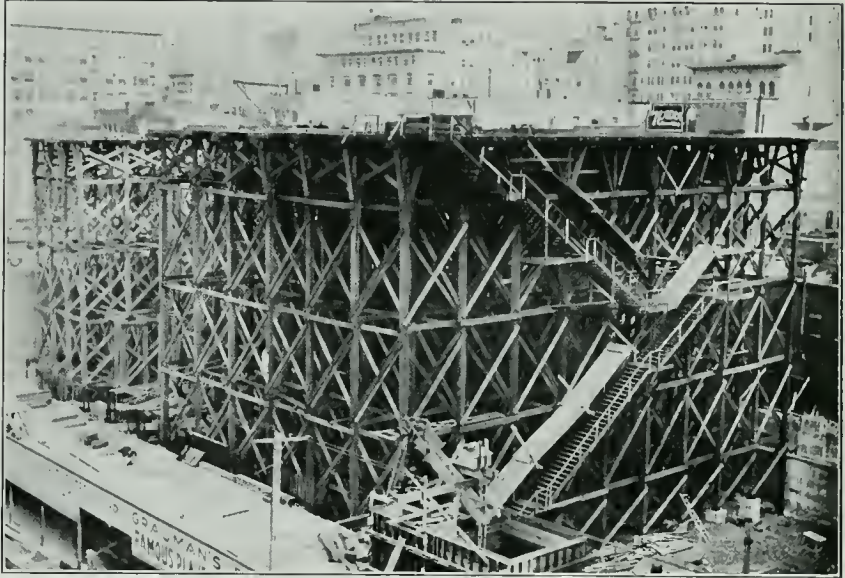

FALSE-WORK USED TO CARRY LARGE REINFORCED CONCRETE TRUSSES,
GRAUMAN'S THEATER, LOS ANGELES

A half-million board feet of selected Oregon pine is being used to erect the false-work which will support eight large girders over the stage, and ten trusses 16 feet in depth, spaced 12 feet 6 inches center to center and spanning 126 feet 6 inches over the auditorium. Each truss will weigh 660 tons.

A glance at the picture will convince the reader that this is the largest false-work ever used in this state on a reinforced concrete building.

This wooden structure consists of one hundred 12-inch by 12-inch columns under the auditorium and sixty-seven similar columns under the stage. These columns are 90 feet high to the outside of the girders and rest on heavy concrete footings which will be used later to support the auditorium floor. These columns are braced rigidly by 3-inch by 10-inch and 3-inch by 12-inch timbers, which are all fastened by $\frac{3}{4}$ -inch bolts.

Every precaution is being taken for the safe construction of this false-work, and only the very best material is being used.

There is a 5-foot covered stairway leading from the ground to the top of the false-work, and additional platforms and safety stations equipped with standard railings and toeboards are provided for the safety and convenience of the 250 workmen engaged on this structure. The top of the false-work is covered with 2-inch planks laid closely together.

Two concrete mixing plants are located at each end of the building, and it is proposed to pour each girder at one time. One of these mixing plants will be used only in an emergency, in the event the other should break down.

The capacity of this theater will be 4,400. It will be one of the largest movies west of Chicago. A six-story office building is being constructed above the theater.

The work is under the direct supervision of Edwin Bergstrom, architect, and R. C. Mitchell, engineer.

Brick Men Say "Build Now"

IT IS unfortunate for the whole construction industry that the public insists upon comparing the cost of a completed building today with "the cost in 1914." Some bankers have been quoted as saying they would not loan money for construction until "materials go back to pre-war levels." Too much importance is given to the cost of building before the war because there are unavoidable basic reasons why buildings cannot be built now, nor for many years to come, at the same cost as in 1914 or previous to that date. One may as well say he never will eat another beefsteak until it goes back to 20 cents a pound, or that he will not hire another day's work done until wages go back to a dollar a day. We all remember when the best hotels and restaurants served a cracker-jack "business men's luncheon" for 50 or 60 cents. We do not stop eating in the middle of the day because the same luncheon costs \$1 to \$1.50.

Had there been no war the cost of building today would have been higher than in 1914 because even at that time it was going up steadily, along with the general standard of living. Buildings were growing better and were worth more.

City and State building codes require more fire resistive construction, safer electric wiring and sanitary equipment. People outside of code areas demand wholesome and modern construction.

In addition to an advance of probably 25% in building cost over 1914 that normally would have taken place without war, we have to absorb these war costs: Increased freight rates (which on brick amount to from 100% to 250%); increased wages; higher fuel costs; higher taxes; and inflation due to waste of invested capital. Building costs cannot go back to 1914 levels because freight rates cannot be reduced (the railroads are not making money enough even at present high rates, they claim); wages will go lower, but not back to 1914 standards, because the cost of living is higher, due to inflation and higher taxes. Taxes will remain high for many years because we have an unprecedented bill to pay.

The man who in any way blocks or discourages construction because he awaits 1914 prices is not in tune with the times.

Speaking for common brick, a reduction of 27% from the peak is noted in the reports of 132 companies just compiled. On February 1 the average delivered on the job price of the companies reporting was \$18.05. This month the average is \$17.40. Of course, it is unnecessary to explain that averages do not mean anything under these circumstances except to indicate a gradual trend downward.

There is nothing in the report to indicate that lower prices have stimulated building. Out of 132 plants 115 were closed during February. On March 1, 22 of these that were closed for repairs or weather, resumed. There is still further reduction of stocks on hand. The excess of stocks on orders is now about 211,000,000. Only 16,180,000 brick were produced during February, and 27,561,000 were shipped from plants. Southern California, where the new Ideal brick hollow wall is established, continues to be the brightest spot from the sales standpoint. One company reports sales of 500,000 brick for Ideal wall construction and a 400% increase in cash business since the introduction of this better way to use brick.

The manufacturers are practically unanimous in reporting satisfactory labor supply. Ten say outlook for future is "good," 50 say "fair," 43 "poor" and 15 "bad."

Forty-three concerns find cost of production lower, the same number exactly say there is no difference in costs. Only two report higher costs.

From many authorities outside the industry come statements that building costs are well stabilized and the public is being urged to begin operations. It is argued that certain materials are selling below cost and that a sharp revival would send prices up. On the whole, the person who builds now, and builds well, cannot lose. In only the flimsy, makeshift construction and the portable or ready-cut stuff is there danger of rapid loss from depreciation. The present emergency does not justify resorting to such inferior building in any part of the United States.—Common Brick Manufacturers' Association of America.

* * *

Some Things That Need Study in the Field of Concrete

THE Committee on Research of the American Concrete Institute in its report to the recent convention gives the following subjects that need study in the field of concrete:

1. Proper methods of measuring quantities going into a batch of concrete.
2. Collection and correlation of data to show quantity of set concrete which can be made from given amounts of different aggregates.
3. Establishment of a standard screen scale for concrete aggregates and limits of variations in sizes of different classes of aggregates.
4. A standard field method for determining consistency of concrete.
5. A standard field test for strength of concrete.
6. Tests to ascertain the efficiency of various types of mixers in making concrete.
7. The allowable variations in sizing of aggregates.
8. An index of quality of aggregates as determining their value in concrete.
9. An abrasion test for gravel.
10. The production of plant-mixed aggregate.
11. A method of evaluating various forms of mechanical anchorage of reinforcing bars in reinforced concrete beams and slabs.
12. The value of clay tile built in with concrete beams in adding to the shearing resistance of the beam.
13. Relative values of rectangular and T-shaped or I-shaped reinforced concrete beams in resistance to shear.
14. A method of evaluating bent-up bars as shear reinforcement for concrete beams.
15. A study of corrosion in reinforcement in contact with salt water or salt air.
16. Bond stresses in two-way reinforcing, as in footings.
17. Adjustment of steel stresses due to plasticity of concrete.
18. Test of chuted concrete.
19. Central mixing plants.

* * *

The American Specification Institute

AS heretofore produced specifications have been largely the product of individual effort, and as such vary in many features that can be conventionalized so as to be common to all. Owing to a present lack of means for collecting and distributing information concerning specifications and the writing thereof, there is a needless duplication of study, research and labor on the part of specification writers. Practically all other professions are so organized that the interchange of knowledge is effected with resulting improvement in the

quality of production and professional standing. It is to improve the conditions affecting the writing of specifications and to benefit by organized effort that The American Specification Institute is organized. This organization is intended to be national in scope and invites co-operation of all those interested in specifications. The plan and scope of this organization follows:

PURPOSE

1. To increase knowledge concerning and improving the methods of writing specifications. The kinds of specifications included are those for buildings, engineering structures and all works whatsoever in which materials of construction and labor are used; for the installation and use of mechanical and sanitary apparatus and equipment; for the fabrication and installation of all furnishings and furniture; for all ornaments and ornamentation, both interior and exterior; for paving, planting, embellishing and improving of grounds and waterways; and for such other things as are produced or sold on specifications.

2. The Institute will not interfere with any of the present organizations, such as

- a. The American Society for Testing Materials;
- b. Kindred national and local architectural and engineering societies;
- c. Manufacturers' and trade associations;

but will endeavor to carry forward the activities of such and give additional assistance to specification writers.

BENEFITS TO BE OBTAINED

The architectural and engineering professions will gain through

- a. The development of specification writers;
- b. The development of specifications that will eliminate cause for argument and guess work and lower the cost of building construction by eliminating waste of labor and materials;
- c. Professional recognition of specification writers.

MEMBERSHIP

Will be composed of

1. Active members—
 - a. Persons who devote their entire time or a part thereof to the writing of specifications.
2. Associate members—
 - a. Persons who employ specification writers.
3. Honorary members.
 - a. Testing and laboratory engineers.
 - b. Instructors in specification writing in architectural and engineering schools.

ACTIVITIES OF ORGANIZATION

1. Study of materials—
 - a. The production and physical properties of raw materials;
 - b. Methods of manufacturing, fabrication and finishing;
 - c. Relative value based on appearance, initial cost and maintenance, effect of combination with other materials and proper materials for various types of buildings of varying grades.
2. Methods of writing specifications—

A study will be made of

 - a. The means of accomplishing complete co-operation between the drawings and specifications and determining.

Notes and Comments

We are told in the Scriptures that "as a man thinketh in his heart, so **Dearth of Building** is he." A Western **May be Due to** banker says that the **State of Mind** present stagnation in our industry and commerce is due almost wholly to a "state of mind," and a writer in *Power* gives us this:

"I believe that much of the individual unrest is due entirely to mental condition. We have heard so much of this talk, have read so much about it, we are saturated with the idea that everything is wrong in our own individual lives. A large share of our trouble is of our own making, and what we all need is to pause a few moments and take stock of ourselves, see where we are, if we have any real grievance, and get busy to try to find the remedy."

Over in Canada there is under way a systematic campaign for the return of "public confidence," simply another term for a change in the public mind. A similar movement is in progress here. Pessimism was never known to bring anyone anything good. But there is some hope for the optimist.

Mr. Willis Polk has addressed the following splendid letter to the editor of the *San Mateo News*. **Save the Trees** Leader, which is deserving of the widest publicity:

Dear Sir:

If, under the leadership of your paper, the Three Cities Chamber of Commerce, Women's Clubs, and other organizations, public sentiment can be crystallized to the end that further cutting of trees along the Highway will be retarded or stopped, a good work will be done. If not, the logical thing to do would be to seek a solution of the problem or a remedy for the evil.

I wish that you might interest the city's big dailies so that they would detail a camera man and a write-up artist to tour the Highway—they could be shown a few examples where private owners have preserved the trees in such a way that an effect of positive charm has been

achieved; however commonplace their houses may be these houses themselves appear distinguished. On the other hand, the camera at the same time would relentlessly expose in this district the ruthless destruction of numberless trees—to see them corded up would vividly recall and be comparable only to the desecrated fruit trees prostrated in France during the havoc of war.

There is no excuse for cutting these trees, except the ordinary one, founded on thoughtlessness, ignorance, cupidity or stupidity.

But to call such action upon the part of private property owners a crime, though it is their right, is not fair. Call it a mistake, if you please, and let it go at that.

California has so far been profligate in dissipating its natural heritages. We have thought nothing of logging the noble redwood in its prime of two thousand years of maturity, for no other purpose than to make shingles—shingles that at best can endure but twenty years. Of course we must have shingles, either redwood, clay-tiles, galvanized iron, pine, or tar and paper, but that is no reason for cutting down trees on the Highway. At the same time the future prosperity of this district depends upon an influx of population carrying with it the building of many new homes, but must these homes be built at the expense of the trees along the Highway?

If existing conditions compel the sacrifice of these trees, maybe there is no remedy—maybe these trees must fall in the march of progress—I do not think so, as witness the few charming examples that already exist where the trees have not been sacrificed. However, let us look at the darkest side of the problem and ask ourselves seriously what is the best thing to do. What could be the remedy? If existing conditions are detrimental to trees along the Highway, why not adopt a policy for the future?

The State and the nation propose vast Highway construction projects—would it not be wise that restrictions be fixed that buildings should not be constructed closer than 75 feet thereto? Such a restriction would preserve trees where they exist and encourage the planting of trees where none exist.

The restricted residence district has in nearly all cities, proved successful—if private real estate promoters can profit by restrictions, why should not the State and nation profit in like manner?

Very truly yours,

WILLIS POLK.

American Institute of Architects

(ORGANIZED 1857)

OFFICERS FOR 1920-21

PRESIDENT.....HENRY H. KENDALL, Boston
FIRST VICE-PRESIDENT.....CHARLES A. FAVROT,
New Orleans, La.
SECOND VICE-PRESIDENT.....WM. B. FAVILLE,
San Francisco
SECRETARY.....W. STANLEY PARKER, Boston, Mass.
TREASURER.....D. EVERETT WAID, New York

San Francisco Chapter

PRESIDENT.....G. A. APPLEGARTH
VICE-PRESIDENT.....EARNEST A. COXHEAD
SECRETARY-TREASURER.....J. S. FAIRWEATHER
DIRECTORS
W. B. FAVILLE WM. MOOSER JOHN REID, JR.

Southern California Chapter

PRESIDENT.....EDWIN BERGSTROM
VICE-PRESIDENT.....HENRY F. WITHEY
SECRETARY.....R. GERMAIN HUBBY
TREASURER.....ROBERT H. ORR
Executive Committee
A. M. EDELMAN D. C. ALLISON S. B. MARSTON

Portland, Ore. Chapter

PRESIDENT.....W. C. KNIGHTON
VICE-PRESIDENT.....JOHN V. BENNES
SECRETARY.....FOLGER JOHNSON
TREASURER.....O. R. BEAN
TRUSTEES.....{ ELLIS F. LAWRENCE
JOSEPH JACOBBERGER

Washington State Chapter

PRESIDENT.....CHARLES H. ALDEN, Seattle
1ST VICE-PRESIDENT.....D. J. MYERS, Tacoma
2D VICE-PRESIDENT.....A. J. RUSSELL, Tacoma
3D VICE-PRESIDENT.....H. C. WHITEHOUSE, Spokane
SECRETARY.....HAROLD O. SEXSMITH, Seattle
TREASURER.....CARL SIERRAND, Seattle
DIRECTORS.....{ A. H. ALBERTSON
J. S. COTE
G. C. FIELD

California State Board of Architecture

NORTHERN DISTRICT

PRESIDENT.....CLARENCE R. WARD
SECRETARY-TREASURER.....SYLVAIN SCHNAITTACHER

Members

J. R. MILLER EDWARD GLASS J. J. DONOVAN

SOUTHERN DISTRICT

PRESIDENT.....JOHN PARKINSON
SECRETARY-TREASURER.....A. M. EDELMAN

Members

W. H. WHEELER MYRON HUNT W. J. DODD

San Francisco Architectural Club

President.....T. L. Pflenger
Vice-President.....Wm. Watson, Jr.
Secretary.....L. A. Bryant
Treasurer.....Wm. K. Dumbavant
Directors—Pas. Brouchoud, F. G. Monk, S. D. Willard.

San Francisco Society of Architects

President.....W. C. HAYS
Vice-President.....LEWIS P. HOBART
Secretary-Treasurer.....H. H. GUTTSON
Directors.....{ GEO. A. LANSBURGH
JOHN REID, JR.

Washington State Society of Architects

PRESIDENT.....HENRY H. JAMES, Seattle
1ST VICE-PRES.....CLAYTON D. WILSON, Seattle
2D VICE-PRES.....JULIUS A. ZITTEL, Spokane
3D VICE-PRES.....WATSON VERNON, Aberdeen
4TH VICE-PRES.....RICHARD V. GOUGH, Okanogan
SECRETARY.....EDGAR BLAIR, Seattle
TREASURER.....L. L. MENDEL, Seattle
TRUSTEES:—H. H. JAMES, FRANK FOWLER, A. WARREN GOULD, W. J. JONES, R. H. ROWE, all of Seattle.

American Society of Landscape Architects

Pacific Coast Chapter

PRESIDENT.....W. D. COOK, JR.
H. W. Hellman Bldg., Los Angeles, Calif.
VICE-PRESIDENT.....STEPHEN CHILDS
Fairmont Hotel, San Francisco, Calif.
SECRETARY-TREASURER.....E. T. MISCHER
Henry Bldg., Portland, Oregon

Tacoma Society of Architects

PRESIDENT.....Roland E. Borhek
VICE-PRESIDENT.....Earl Dugan
SECRETARY AND TREASURER.....A. J. Russell

San Diego Architectural Association

PRESIDENT.....WM. TEMPLETON JOHNSON
VICE-PRESIDENT.....ROBERT HALLEY, JR.
SECRETARY-TREASURER.....E. C. DECKER

American Society of Civil Engineers

San Francisco Association

PRESIDENT.....M. M. O'SHAUGHNESSY
1ST VICE-PRES.....W. L. HUBER
2ND VICE-PRES.....F. R. MUHS
SECRETARY AND TREASURER.....NATHAN A. BOWERS

BOARD OF DIRECTORS

W. L. HUBER M. M. O'SHAUGHNESSY
F. R. MUHS E. J. SCHNEIDER NATHAN A. BOWERS

Address all communications to the secretary, 502 Rialto Bldg., San Francisco.

Southern California Association

President.....H. W. Dennis
First Vice-President.....R. J. Reed
Second Vice-President.....F. D. Howell
Treasurer.....E. R. Bowen
Secretary.....F. G. Dessery
DIRECTORS—H. W. Dennis, Ralph J. Reed, F. D. Howell, E. R. Bowen, F. G. Dessery, G. G. Anderson, W. K. Barnard.

Address all communications to Secretary F. G. Dessery, 619-20 Central building.

American Association of Engineers

PRESIDENT.....L. K. SHERMAN
FIRST VICE-PRESIDENT.....H. O. GARMAN
SECOND VICE-PRESIDENT.....A. B. McDANIEL
R. W. BARNES.....Portland
FREDERIC BASS.....Minneapolis
R. A. BERTENSHAW.....Cincinnati
W. C. BOLIN.....Chicago
RAYMOND BURNHAM.....Chicago
C. E. DRAYER.....Secretary
National Headquarters, 63 E. Adams St., Chicago

SAN FRANCISCO CHAPTER

PRESIDENT.....G. CHESTER BROWN
FIRST VICE-PRESIDENT.....W. H. PHELPS
SECOND VICE-PRESIDENT.....L. D. HOWLAND
TREASURER.....R. E. DODGE
SECRETARY.....F. T. AMWEG

Permanent address, 960 Pacific Bldg.

LOS ANGELES CHAPTER

PRESIDENT.....CARL A. HEINZE
FIRST VICE-PRESIDENT.....H. Z. OSBORNE, JR.
SECOND VICE-PRESIDENT.....MYRON HUNT
TREASURER.....E. H. MERRILL
SECRETARY.....WILLIS S. PEPPER

Permanent address, 625 Metropolitan Bldg., Los Angeles.

With the Architects

Building Reports and Personal Mention of Interest to the Profession

Architects Meet

Mr. Arthur B. Benton was host to the Southern California Chapter of the American Institute of Architects at his office and studio, Casa de Alcalde, May 10th. Mr. Benton is an eminent authority on early mission architecture, and the meeting was in commemoration of California, its discovery, conquest and romantic history. Mr. John Stephen McGroarty, noted writer and dramatist and author of the Mission Play, was the guest of honor.

Plans for the June meeting, which will be held on Mt. Wilson, and for the July meeting, which will be held at Santa Barbara, were discussed.

Pasadena Hospital

Mr. Myron Hunt, 1107 Hibernian building, Los Angeles, has completed plans for the new buildings to be erected on Congress street, near Pasadena avenue, Pasadena, for the Pasadena Hospital Assn. The main structure will be a four-story fireproof bedroom addition. It will be 47x261 ft., with a central wing 47x100 ft., and will contain 100 rooms, each with lavatory and toilet, with numerous bathrooms. There will also be a two-story and basement power house and laundry building, 38x60 ft., and a concrete tunnel, 225 ft. long, to connect with the main building. This building will have two hydro-electric elevators.

Community Apartment House

Plans are being prepared in the office of Mr. Harry P. Merritt, 802 American National Bank building, San Francisco, for an eight-story class "A" community apartment house to be built on the site of the old E. A. Denicke home at Sacramento and Mason streets, San Francisco. The project is being handled by Mr. Marcus Marcussen, a San Francisco builder who states that it will be the largest community apartment house west of Chicago, and will involve an expenditure of more than \$1,500,000. There will be forty-seven spacious apartments in the building.

American Legion Building

Messrs. Morrow & Garren, architects in the Chronicle building, San Francisco, are preparing plans for a two-story steel and concrete club building and boxing arena for Golden Gate Post, No. 40, American Legion. The site is at Turk and Polk streets. The auditorium will seat 5000 persons. The same firm is preparing plans for a \$15,000 home which Mr. Morrow will build on his property in Piedmont.

Vallejo Office Building

Mr. Chas. E. Perry, Jr., architect of Vallejo, has plans practically completed for a six-story Class "B" reinforced concrete store and office building on Georgia street, between Main and Sacramento streets, Vallejo, for Messrs. Fisch and Higgins, local merchants. The ground floor will contain two twenty-five foot stores, while the upper floors will be divided into office suites.

Sacramento Hospital

Messrs. Frederick H. Meyer and Al-bion Johnson, architects of San Francisco, have been commissioned to prepare plans for a large hospital which Sacramento physicians are financing. The same architects are designing the new \$200,000 Elks' club building, at Bakersfield.

San Francisco Hotel

According to the daily press, the Bowman Hotel Company of New York, is to have a big hotel in San Francisco. The company's general manager, Mr. James Woods, was recently in the city with the hotel's architect, Mr. Leonard Schultz, of New York. Several desirable sites were inspected.

\$25,000 Berkeley Home

Mr. J. H. Holmes of Piedmont has commissioned Mr. James W. Plachek, 2014 Shattuck avenue, Berkeley, to prepare plans for a two-story and basement frame and stucco residence and garage to be erected on his property at Avalon Court, Berkeley. The house and landscape work will cost \$25,000.

Drops Twenty-one Per cent

An Akron contractor has submitted the following estimate of the cost of a double-constructed, six-room dwelling, 20x26. The table shows the 1920 peak prices of the various items entering into the construction of the house and the prices as estimated on March 1, 1921. These figures show a decrease of \$1,309.10, or 21 per cent in the cost of the dwelling, according to the Associated General Contractors' Bulletin:

Six-Room House for \$4,893.75

	Peak 1920	March 1, 1921
Lumber	\$1,831.60	\$1,356.00
Plaster	613.05	426.00
Roof	157.50	85.50
Plumbing	525.00	450.00
Painting	250.00	175.00
Electrical	90.00	65.00
Foundation	575.00	330.75
Heating	250.00	200.00
Chimney & Fireplace.	150.00	135.00
Sheet Metal	60.00	45.00
Hardware	140.00	125.00
Labor	1,559.95	1,300.00
Incidentals	200.00
	<u>\$6,202.85</u>	<u>\$4,893.75</u>

Have Much Work

Messrs. Sidney B. & Noble Newsom, Nevada Bank building, San Francisco, have completed plans for a \$50,000 reinforced concrete commercial garage for the Service Garage Company, Oakland; also they have made drawings for a two-story and basement reinforced concrete store and restaurant building in San Francisco Chinatown for Fong Kim; a \$15,000 residence in Santa Cruz for Mr. Deming Wheeler, and for altering a two-story frame residence into twelve apartments at 1819 Seventh avenue, Oakland.

Will Design Auditorium

Messrs. Houghtaling & Dougan, architects, Elks Club building, Portland, have been selected to prepare plans and specifications for the proposed municipal auditorium at The Dalles, Oregon.

The building will cost \$125,000 and bonds have already been voted. A building to be two stories high and constructed of brick with terra cotta trimmings is planned.

Addition to Bank Building

Messrs. Reed & Corlett, architects in the Oakland Bank of Savings building, Oakland, have been commissioned to prepare plans for an eight or twelve-story class "A" addition to the Oakland Bank of Savings building, at Twelfth and Broadway. Approximately \$1,000,000 will be expended on the improvement.

Opens Oakland Office

Mr. James T. Narbett has opened an office in room 503, Easton building, Oakland, to practice architecture. This will be maintained in conjunction with his Richmond office.

Mr. Narbett will build an apartment house on Bellevue and Staten avenues, facing the lake in Oakland. The building will be class "C", with hollow tile and concrete exterior walls and cement stucco front. There will be 21 four-room apartments, elevator, and all modern conveniences. The project will represent an investment of \$75,000.

Hotel Additions

Mr. Arthur B. Benton, 1548 Sunset boulevard, Los Angeles, has prepared plans for alterations and additions to be made to the Arlington hotel at Santa Barbara. The carriage driveway will be enclosed and divided into twenty rooms and a hairdressing parlor. The ball-room will be converted into a lounging room, a new ball-room located in the present grill, and a new grill installed in the old bar room.

Twelve-Story Hotel

Messrs. Morgan, Walls & Morgan, 1124 Van Nuys building, Los Angeles, have been commissioned to prepare plans and specifications for a twelve-story and basement class "A" hotel building to be erected on the east side of Olive street, between Sixth and Seventh streets, for the Phillips-Walker Syndicate.

Col. Marshall Addresses Engineers.

Colonel R. B. Marshall, member of the American Society of Civil Engineers, and author of "The Marshall Plan," explained his proposed method of water conservation and storage in California, at the meeting of Los Angeles Section, May 11, at the Jonathan Club. Colonel Marshall used maps and diagrams to illustrate his talk.

Union Oil Building

Mr. John Galen Howard, First National Bank building, San Francisco, has completed plans for the new administration and laboratory building to be erected at Wilmington for the Union Oil Co. The estimated cost is \$300,000.

Brick Building

Mr. W. C. Pennell, 204 Chapman building, Los Angeles, has prepared plans for a one-story brick automobile building to be erected at 808 W. Washington street for Mr. G. H. Mallman.

Landscape Architects Affiliate

It doubtless will be of interest to the profession to hear that there has been an affiliation between the Southern California Chapter of the American Institute of Architects and the Pacific Coast Chapter of the American Society of Landscape Architects.

The objects of this affiliation is that there may be closer cooperation and understanding in matters of mutual interest and service to the community and the welfare of the two professions, and it is provided that the officers of one society shall be invited to attend meetings of the other society and to actively engage in discussion of matters of mutual interest.

The Pacific Coast Chapter of the American Society of Landscape Architects has also become a member of the Joint Committee of Technical Societies, an association consisting of the following societies: The American Chemical Society, the American Institute of Architects, American Institute of Electrical Engineers, American Institute of Mining Engineers, American Society of Civil Engineers, American Society of Mechanical Engineers, American Association of Engineers. Luncheons are held every Thursday and each society in turn arranges a programme, consisting of short talks on subjects that are well worth knowing more about, the idea being that there may be more concerted action on matters of public interest.

Bank Building

Mr. William Mooser, architect in the Nevada Bank building, San Francisco, has been commissioned to prepare plans for a two-story bank and office building for the Lassen Industrial Bank at Susanville. The building will have either terra cotta or white cement exterior. The improvements are expected to cost \$100,000.

Gilroy Hotel

Plans are being prepared by Mr. William H. Weeks, 75 Post street, San Francisco, for a three-story reinforced concrete store and hotel building in Gilroy for Mr. George Milias. There will be 66 rooms. The hotelery is to cost \$100,000.

Sutter Street Apartments

Mr. Louis D. Stoff will build a \$75,000 four-story Class "C" apartment house on Sutter street, west of Leavenworth, San Francisco, from plans by Mr. Albert Schroeffer.

Country House for Willows

Mr. N. W. Sexton, Chronicle building, San Francisco, has prepared plans for a \$16,000 country house for a client in Willows, Glenn county, California.

Santa Rosa Department Store

Mr. Sylvain Schnaittacher, 233 Post street, San Francisco, has been commissioned to prepare plans for a reinforced concrete department store and office building in Santa Rosa for Mr. Max Rosenberg at a cost of \$200,000. Mr. Joseph Cahen was the original architect selected to design this building, but his advent into the hotel business made it necessary for him to give up his architectural practice.

Architect Knoll Busy

New work in the office of Mr. A. H. Knoll, Hearst building, San Francisco, includes a one-story addition, together with extensive alterations, to the Hotel Benson on the southeast corner of Turk and Taylor streets, and extensive alterations, including a new cement plaster front, to the six-story store and loft building at 520 Mission street, San Francisco. The Hotel Benson improvements will cost \$55,000, while the alterations to the Mission street building will approximate \$28,000.

Mills College Dormitory

A two-story frame and stucco dormitory to accommodate 67 students will be built at Mills College by E. T. Leiter & Son, from plans by Messrs. Bakewell & Brown, 251 Kearny street, San Francisco. The building will cost \$66,000.

Masonic Temple

Yreka Lodge of Masons, Yreka, Siskiyou county, will construct a \$60,000 lodge building and moving picture theater, from plans by George Sellon & Company, architects of Sacramento. The same firm has been commissioned to prepare plans for a new hollow tile school at Patterson to cost \$40,000.

Chico Architect Busy

Mr. Chester Cole reports that he is preparing plans for a \$10,000 store building for the Breslauer Estate, also a \$12,000 residence at Chico for Mr. J. H. Richardson, and he has completed drawings and work has been started upon a \$11,000 residence at Oroville for Mr. E. A. Kusel.

Funston Avenue Residence

Mr. S. Heiman, 57 Post street, San Francisco, has prepared plans for a \$12,000 nine-room residence to be built on Funston avenue, north of Cabrillo, San Francisco, for Mr. Bernard Fieroty.

Architects Attend Convention

Major Charles H. Alden, president of the Washington State Chapter, American Institute of Architects, and Messrs. A. H. Albertson, of the firm of Howells & Albertson and H. O. Sexsmith, all of Seattle, were delegates to the 54th annual convention of the American Institute of Architects, held in Washington May 11, 12 and 13. The delegation was joined by Architect Albert Held at Spokane. At the convention of the national body one of the chief subjects considered was the matter of how best the institute can assist home building throughout the United States.

Attend National Convention

Southern California Chapter, American Institute of Architects, had the largest representation in its history at the recent Institute convention in Washington, D. C. Those attending were Messrs. Edwin Bergstrom, Robert H. Orr, R. Germain Hubby, Octavius Morgan, and John Parkinson. Mr. Richard S. Requa of San Diego also attended.

Architectural Club

The members of Los Angeles Atelier, together with other architectural draftsmen, have formed a new architectural club. The membership of the Atelier is to form the nucleus of the new organization and the plan is receiving the support of a number of prominent architects.

Berkeley Architect Busy

Recent work turned out in the office of Mr. W. H. Ratcliff, Jr., Berkeley, includes two apartment houses, one for Mr. Hiram Brasfield on Durant street, near Telegraph avenue, and the other for Mr. A. S. Brasfield, also a residence in Burlingame for Mr. A. W. Stitt.

Modesto Telephone Exchange

Mr. E. V. Cobby, head of the architectural department of the Pacific Telephone & Telegraph Company, has completed drawings for a 'phone exchange building at Modesto. It will be of the mill construction type, brick exterior, and will cost \$45,000.

Ten Story Apartment House

Mr. Kenneth MacDonald, 234 Pine street, San Francisco, is preparing plans for a ten-story concrete apartment house to be built at Laurel and Jackson streets, San Francisco, for Mr. John D. McKee of the Mercantile Trust Company.

Engineers Join Forces

Messrs. Joseph Jacobs and Archibald O. Powell announce that they have associated themselves under the firm name of Powell & Jacobs, civil engineers with offices at 613-616 Thompson building, Seattle. Each member of the firm has been prominently identified with engineering practice in the Northwest for many years.

Designing Bungalow Court

Mr. Harold B. Dunn, 6665 Hollywood boulevard, Los Angeles, is preparing plans for a bungalow court to be erected at Monrovia. Mr. Dunn is also the owner. There will be a total of seven bungalows. The cost is estimated at \$30,000.

Country Club Building

Messrs. Edelman & Barnett, H. W. Hellman building, Los Angeles, have prepared plans for a frame country club building to be erected on Pico boulevard, Los Angeles, west of Los Angeles city limits for the Hillcrest Country Club.

Site For Palo Alto School

The Palo Alto Board of Education has purchased two blocks of land in South Palo Alto as a site for the new \$80,000 elementary school building being designed by Messrs. Chas. K. Sumner and W. C. Hays, associated. The new building is to be frame with stucco exterior and will contain eight classrooms.

Newspaper "Accuracy"

The bay school controversy came up again when a letter from J. Howard Galen, architect of the University of California, was read in which the architect declined to act as an inspector to pass on the building. No action was taken on the letter.—Oakland Enquirer.

Portland Hospital

Messrs. Claussen & Claussen of Portland have been commissioned to prepare plans for a hospital and sanatorium for the Portland Hospital and Benevolent Association. It will be built at East 60th and Yamhill streets, Portland, and will cost \$125,000.

Attended Washington Convention

San Francisco Chapter, A. I. A., was represented at the institute convention in Washington by the following delegates: Messrs. E. A. Coxhead, S. Schnaitacher, Wm. C. Hays, C. H. Cheney, W. B. Faville, and F. J. De Longchamps.

With the Engineers

Reports from the Various Pacific Coast Societies,
Personal Mention, Etc.

The Engineer's Place in Politics

By J. J. ROSEDALE,
Construction Engineer, Industrial Accident
Commission

At no time in the history of the engineering profession was there a greater need for the engineer to take his place in politics than at the present time. One definition of an engineer is "A person who can make the dollar go the farthest." To prove that this definition is true, reference need only be made to what Herbert Hoover and the United States army engineers have done in the recent world war. Some of the greatest statesmen have said that this war was a war of ingenuity (engineering). Our present crisis needs also an army of engineers to straighten out the industrial problems and hasten business enterprises to a normal condition.

Everywhere there is a cry for economy, especially in the operation of our federal and state governments. Engineers are needed in Congress and our state legislature to participate in such reforms as creating a national or state board of public works; the consolidation of certain commissions or departments; and the drafting of laws pertaining to engineering problems. We have too many lawyers making our laws and hardly any engineers, even though there are numerous bills involving engineering problems to be disposed of.

The engineer has always been backward about entering politics. The reason for this is because the average engineer claims that he cannot be an engineer and politician at the same time. Our politics have now reached the stage, however, where we cannot longer be engineers unless we are politicians.

Thinks Consulting Engineers' Future Very Dubious

"The Future of Engineering" as viewed by a consulting engineer was discussed in a most interesting manner by Mr. George W. Fuller, noted consulting engineer of New York City, at the regular meeting of Los Angeles Section, American Society of Engineers, at the University Club, Los Angeles, April 13. Mr. Fuller, together with Mr. George C. Whipple of Harvard University, and

Mr. Wm. Mulholland, chief engineer of the Los Angeles department of public service, comprise the commission reporting on Los Angeles sewage disposal problems.

Mr. Fuller said frankly he did not see great promise in the future for the consulting engineer. His field has been gradually encroached upon by engineers representing financial interests and corporations and the development of engineering activities in other directions. Before the war, he said, there was a number of consulting engineers in New York City whose business amounted to \$20,000 to \$30,000 a year. During the war they gave their services to the country. Since they have reopened their offices some of them have not had even enough business to pay office rent. Mr. Fuller referred to the thinning of the ranks of consulting engineers in Europe, particularly in France and Germany, where they have practically disappeared.

Mr. Fuller referred to the American Institute of Consulting Engineers which has 117 members enrolled. This organization had its inception a dozen years ago when structural engineering for buildings claimed the serious attention of the independent engineer. He also narrated his efforts as a director of the United States chamber of commerce to place and keep an engineer on the board of directors of this organization. This had not been an easy task and was only accomplished through persistent and energetic effort.

Count Votes by Machine

Counting and tabulating 25,000 letter ballots for candidates in the national election of officers of the American Association of Engineers offers some interesting problems. The constitution of the association requires that officials shall be inaugurated in office at the annual convention and the last vote is received only three days prior to the annual convention.

It would require a force of 20 men working three days in two shifts to count 25,000 votes. This work is accomplished by a letter ballot and a tabulating machine which is the standard type used for time-card work and has been adapted to this special work. As

fast as the ballots are received they are taken out of the envelope by the tellers, counted as to number and sent to the punching machine where a hole is punched in the ballot to indicate each man's choice. The ballot then passes through a verifying machine which does not punch any holes, but in case the punching is wrong an electric alarm is given.

Sues for Breach of Contract

Mr. Theodore C. Kistner, architect of San Diego, has brought suit in Orange county for \$4000 damages for alleged breach of contract against Messrs. L. F. Pomeroy, George W. Sloop and William M. Chambers, trustees of the Anaheim city school district. Mr. Kistner claims that when the trustees proposed a bond issue, April 15, 1919, for two new school buildings, they entered into an oral contract with him to furnish plans and specifications at a fee of 6% of the cost of structures. He asserts that the bond issue was subsequently voted and he made preliminary drawings for both buildings, but on August 15, 1919, he received notice from the trustees that his services would not be required. The architect claims he spent large sums in the preparation of plans in addition to giving his services.

Associated General Contractors

The new officers of the San Francisco Branch of the Associated General Contractors' Association are: President, George Wagner; first vice-president, Felix Kahn; second vice-president, H. H. Hilp; treasurer, W. C. Duncan; secretary, E. T. Thurston, Sharon building.

Southern California: President, Godfrey Edwards; vice-president, W. W. Brier; treasurer, J. F. Hall; secretary, George A. Rogers; and assistant secretary, B. Read, 430 Douglas building, Los Angeles.

Pacific Northwest: President, Natt McDougall, Portland, Ore.; vice-president, I. N. Day, Portland, Ore.; vice-president for Spokane district, S. G. Morin; for Puget Sound district, Ray Miller; for Portland district, Frank J. Walsh; executive secretary, Lyman Griswold, 506 Railway Exchange building, Portland, Ore.

Bank and Office Building

Messrs. John Parkinson and Donald B. Parkinson, 420 Security building, Los Angeles, have completed plans and are taking bids on the general contract for the erection of a six-story bank and office building to be erected at the corner of Hollywood and Cahuenga boulevards for the Security Trust & Savings Bank.

Engineers Inspect Irrigation Works

About 100 members of the San Francisco Section of the American Society of Civil Engineers and their guests made an inspection trip of various irrigation and reclamation structures along the Sacramento river between Colusa and Sacramento on April 3. The party assembled at Colusa the night before, coming by automobile and train. The river steamer "Colusa" had been chartered expressly for the occasion, and an early morning start was made. Stops were made at various points along the river, including the Tisdale weir, the site of the proposed Fremont weir; the Sutter Basin, Boyers Bend, Tyndall Mound, Rough and Ready, and Conaway pumping plants. Lunch was served aboard the dredge "America," one of the largest reclamation dredges in the world. The party left the steamer at Sacramento.

Specialize in Industrial Wiring

The Brown-Langlais Company, electrical contractors of San Francisco, have taken the agency for Robbins & Myers power motors. The accompanying illustration shows one of these motors, which are manufactured in various sizes and are especially adapted for industrial work.

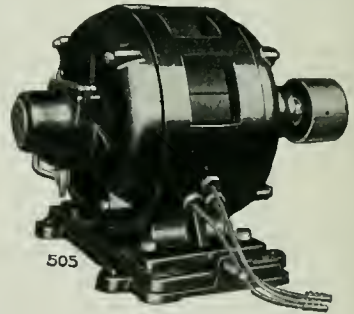

The Brown-Langlais Company, by the way, specialize in electrical installations in factory and industrial buildings, recent contracts which they have completed being the Ford Motor Company's assembling plant at Twenty-first and Harrison streets, San Francisco; the Nucoa Butter Company's plant at Eighteenth and Bryant streets; Hoover Spring Works at Fell and Franklin streets, and the U. S. Navy hospital group, Pearl Harbor.

Los Angeles Building Permits

During the month of April, 1921, the Los Angeles city building department issued 2904 permits with an estimated valuation of \$2,250,571, as compared with 1475 permits with an estimated valuation of \$3,874,472, issued during April, 1920, a gain of about 87%.



Electrical Department

Electrical Equipment of the Modern Theatre*

By CHAS. FELIX BUTTE

THE success of any theatre, particularly places of amusement wholly or mostly displaying pictures, depends greatly upon the arrangement, operation, and reliability of the electrical equipment installed therein. The heart of a theatre displaying motion pictures only is the projection room, and in the past many owners of theatres have found to their regret that sufficient attention had not been given to this part of their equipment. The failure in their projection room, a poorly projected picture or a continual interruption in the continuity of the pictures, has, in many cases, been the difference between a successful house and a failure.

The illumination of the interior has received more attention of late than heretofore. Many theatres now depend wholly upon the numerous lighting effects obtainable to make the interior of the house attractive. These changes are made weekly or bi-weekly, and create variable surroundings that attract regular patrons and create a desire to attend the theatre more frequently than if the house is illuminated in the same manner at all times.

Theatres should be provided with two independent sources of service wherever it is possible to obtain such supply. The dependability of the entire installation is made positive by the installation of such two independent sources of supply. The California State law now requires that where only one source of supply is obtainable such as is the case in the interior cities and towns, an independent source must be provided by means of storage batteries to the capacity of the emergency lighting. The emergency lighting must illuminate the entire house to the extent of one-quarter-foot candle power. The minimum foot candle power has been determined by experience to be the least amount of illumination whereby the patrons can safely leave the theatre. In several recent progressive theatres wherein only one source of supply is obtainable, they have provided an oil engine generator set with auxiliary storage bat-

teries for a break-down service that will operate the projection machines as well as provide sufficient illumination in the house to continue the show without interruption.

The emergency circuit which in the past has been understood to provide for exit lighting only is now extended beyond this limit as stated heretofore and a general illumination is provided throughout the house for the safety of the patrons. The emergency circuit should also be connected to the box office lighting as it would be inadvisable to permit the box office to remain in darkness in the event of an interruption in the power company's service, as darkness in the box office would necessarily cause the discontinuance of ticket selling aside from the risk involved.

The lighting of the auditorium proper requires particular attention to give satisfactory results and to harmonize with the architectural interior. In many of the recent installations, single cove lighting on each side has been provided with success where the auditorium is not of considerable width. In cases where the auditorium is of considerable width interior cove has provided, and in several other cases large ornamental circular fixtures are installed close to the ceiling and have been depended upon more as indirect units than as direct lighting. In designing these ceiling units, the general scheme of ornamentation of the interior has been embodied in the fixture itself in many cases which were made of cast plaster. In the center of each unit a glass bowl was inserted for the purpose of brilliantly lighting the auditorium when desired. Within the cast plaster portion of the fixture lamps are provided for indirect illumination and color effect.

Many theatres are now equipped with the varied color lighting scheme to the extent of four different color circuits in the coves and center fixtures. These color circuits may be burned independently or several at a time, and with the proper lamp colors, beautiful effects are obtainable by the combination of colors. As an illustration, by the burning of red and blue lights, a beautiful magenta color is obtainable. Just as an artist may combine

*Second of a series of articles describing electrical equipments of Pacific Coast theatres, by Mr. Charles Felix Butte of the Butte Electrical Equipment Company, San Francisco, California.



Operating Room, Showing Dissolver Control

various colors to produce the warm tints of sunlight or the drab gray of dawn, so does an operator working with switches, dimmers and controls.

The control of the auditorium lighting should be so arranged that they can be controlled from various points. Generally control buttons are located on the stage, in the projection room, and at times, near the lobby switchboard. Contractors are installed at the most central location and should be so located that their operation cannot be heard in the auditorium. In several instances, this point has been overlooked and each and every time the contractors are operated, the audience can hear the contractors in operation. Preferably, the contractors should be located in the blower room

under the stage or in the generator room of the projection room. The lobby switchboard generally controls the outside lighting and the various rest rooms in the front of the house as well as all emergency lighting.

Another portion of the electrical equipment that is now receiving considerable attention is the proper illumination of the aisles during the projection of the picture when the house is dimmed. Too much care cannot be given this portion of the equipment particularly where steps occur. Many designs and types of aisle lights have been installed but in several recent installations, the writer has provided an adjustable metal plate without glass, using a small wattage lamp with considerable success. These aisle lights should illuminate the aisles, but must not interfere with the vision of the patrons nor detract their attention from the picture. An aisle light that reflects on the back of the chairs or spreads the light any distance is very unsatisfactory, and one with the lamp that can be seen by the patron obtains the same results.

The projection room as stated heretofore is really the main portion of the electrical equipment within the theatre particularly those displaying motion pictures entirely. This room should be provided with two sources of energy independent of one another in each and every case wherever possible to obtain two such independent sources. The source of supply for the projection room machines should at all times preferably be a motor generator set operating from the primary source. In many houses two motor generator sets are provided, using the sets intermittently. The reasons for the intermittent use of the motor generator sets is to keep a set always in operating condition to safeguard the continuity of the projection room service. In cases where one generator is installed, a mercury arc rectifier should be provided for emergency or standby service. The arrangement of the apparatus in the projection room should

HARDWOOD HEADQUARTERS

ASH-BASSWOOD-BIRCH
AROMATIC RED CEDAR
COTTONWOOD-ELM-HOLLY
SOUTHERN RED GUM
HICKORY-LAUREL-MAPLE
OREGON MAPLE-PLAIN OAK
QUARTERED OAK
WYBROCK BENDING OAK
POPLAR-WALNUT



BIRCHWOOD-EBONY-IRONBARK
JENSENO-KOA-SPANISH CEDAR
LIGNUMVITAE-MAH-NGARY
ROSEWOOD-TEAK-RED BEAN
SPOTTED GUM-CIRCADIAN WALNUT
LUMBER-TIMBER
HARDWOOD FLOORING
WYBRO VENEERED PANELS
DOWELS-TREENAILS-VENEERS

WHITE BROTHERS

FIFTH and BRANNAN STREETS

SAN FRANCISCO, CAL.

SPECIFY

STANLEY

GARAGE HARDWARE

IN SETS

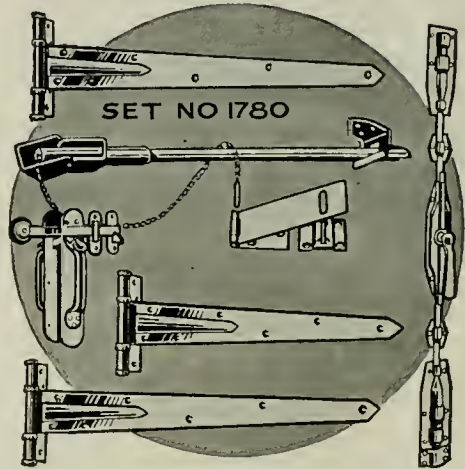

Set No. 1780 applied to the doors of a brick garage.

THE quality of the hardware on a garage determines the kind and length of service the garage will give.

By specifying Stanley Garage Hardware in sets, you are furthering your client's interest towards lasting satisfaction.

Set No. 1780 is recommended for brick and stucco garages. It

includes Stanley Ball Bearing Hinges, 36" long, at the top and bottom panels; 24" long, in the center panel; Garage Door Holder (Cushion Type), Cremone Bolt, which locks the door at top and bottom at one operation and an Extra Heavy Padlock Hasp.

Other Stanley Garage Hardware Sets to meet all requirements. Write for a Garage Hardware Catalog AE-5.



THE STANLEY WORKS

Main offices and plant:

NEW BRITAIN, CONN.

Branch offices: New York Chicago San Francisco
Los Angeles Seattle Atlanta

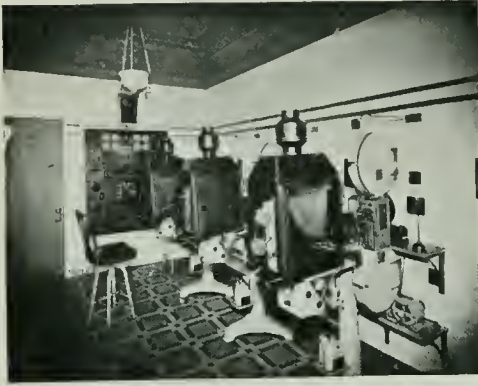

High Class Projection Room Installation

receive considerable thought and should be so arranged as to give the most efficient service for the purpose to which the room will be applied.

In many installations the apparatus is arranged as shown in the plate herewith. The dissolvers are located to the extreme left of the room with the spot and flood lights and projection machines respectively to the right. The port and lookout openings on the face of the operating room are now made a portion of the original construction. The practice in the past has been to make an opening the full length of the room and fill in this opening either with sheet iron work or ebony board, cutting in the ports and lookout openings after the machines are set. No reason exists why these openings cannot be definitely and accurately located during the construction, which makes a much neater appearing and substantial installation. The installation of these openings at the time of constructing the projection room walls overcomes the possibility of a noisy projection room as in many cases in the past the filling in of the long opening, particularly with iron construction, has created a vibrating wall which carries the sound out into the auditorium.

The use of exposed shutters within the projection room is fast becoming a past practice. Many of the projection rooms equipped by the writer are provided with concealed shutters similar to the shutters shown on the print herewith. The types of projection machines is a matter that should be determined in each individual case, and the writer has no desire to recommend any particular make of projecting machines. Many of the installations that are provided with the Simplex projecting machines have proven very successful. The promiscuous installation of wires and exposed conduits within the projection room is a practice of the past and should not be tolerated in any present day equipment. The unsightliness of daugling wires should condemn this prac-

tice in itself, besides the fact that hanging wires are always a possible source of trouble and causes of interruption in service.

There are now three types of projection room arrangements in existence, namely the individual manual operating machine; that is, the projection machine is started and stopped by means of pressing individual switches; the semi-manual automatic control; that is, the first machine is stopped and the second machine started by throwing one switch; and the full automatic which automatically stops the first machine and starts the second or third, etc. The manual needs no further description as this type of installation has been in use for many years past. The semi-manual automatic is of recent development and primarily consists of a double-throw transfer switch which by throwing from one side to the other starts the motor, throws in the contactor, and operates the automatic dousters. With this type of installation a perfect control is rendered and the change of machines from one to the other is hardly noticeable on the screen. The full automatic control which (consists) is of recent development and has been installed in several projection rooms, automatically stops the machine in operation and starts the next machine as soon as the film in the first machine is run through. This system is so arranged to give a perfect change from one machine to the other and dissolves the picture on the screen with the result that it appears as one continuous film. New developments are now taking place along these lines with the possible result that all future installations will be provided with this type of equipment. In order to provide means whereby the operator can start a picture without interruption in several cases the writer has provided an attachment connected with the dissolver whereby they can be operated from any portion of the room. This system primarily consists of a rod with lever attachments as is shown in the illustration.



Generator and Ballast Equipment

The PUBLIC Meets the ARCHITECT

THE great modern hotel, of the type of the Blackstone in Chicago, offers the public a more interesting opportunity to meet the architect than is found in most buildings.

Here the architect has created an environment of comfort, luxury and entertainment; he has symbolized hospitality and designed a public palace; he has designed not for the few but for the many.

The Hotel Blackstone, detailed in Terra Cotta, is one illustration for a National Terra Cotta Society page advertisement in *The Literary Digest*. Architects are following with great interest this series of unusual advertisements which are written to stimulate general appreciation of architecture, and a greater recognition of the beautiful, permanent and profitable properties of Terra Cotta.



1921, National Terra Cotta Society Drawing by Charles Morgan

BLACKSTONE HOTEL, CHICAGO

All trim above base course
is cream glazed Terra Cotta

MARSHALL & FOX, Architects

NATIONAL TERRA COTTA SOCIETY is a bureau of service and information. Its publications cover not only the technical and structural use of the material but show, as well, examples of its application to buildings of various types.

Brochures of specific value, as indicated by their titles, will be sent to Architects on request addressed to National Terra Cotta Society, 1 Madison Avenue, New York, N. Y.

The School The Theatre The Garage
The Store The Bank

TERRA COTTA—STANDARD CONSTRUCTION
A valuable Technical Reference Work for Architects and Engineers

TERRA COTTA DEFINED

This new booklet, intended primarily to inform the layman, will nevertheless prove interesting to Architects who like to review buildings the country over

TERRA COTTA

Permanent

Beautiful

Profitable

The recent developments along the lines of the safety act of California have called upon a new method of installation of the stage switchboard controls and the usual exposed live parts of switches and fuses on the face of the stage switchboard is now fast disappearing. The type of stage switchboard known as the "dead front panel" will be the standard type of installation provided in all modern theatres, and is now required by the National Code.

Recent developments in border lighting apply larger single units in preference to the smaller distributing units used in the past. Color-screens are provided with these larger units and in several recent installations an automatic color changing device has been attached to the border to change the color scheme automatically similar to the method used for color flood-lighting. Automatic curtain controls which can be operated in many instances from the projection room as well as from the stage have been installed. These automatic curtain devices provide for lifting the curtain as well as drawing the draped curtain horizontally. Effective results are obtained, particularly in strictly motion picture theatres, by providing a velour or similar drape to be drawn over the screen while the orchestra is rendering an overture or during the intermission. These drapes are generally operated by means of an automatic curtain mechanism and controlled from the operating room. In several installations, the same effect has been obtained by the use of a third dissolver although the effectiveness of this means of curtaining the screen is not as pleasing as the draped velour effect.

In addition to the usual dimmers on the stage for the foots and borders, provision has been made in many installations to dim the house lighting system. Beautiful effects are obtained by the use of these dimmers from the fact that the house is never instantaneously and brilliantly illuminated. Changing effects from one color to the other is harmoniously accomplished by dimming the color lit and bringing up the color to be lit. In many installations, the house dimmers are automatically operated and controlled from the projection room as well as from the stage. In other cases the house dimmers are located in the projection room and are manually operated from this point. In these cases the theatre is primarily used for motion pictures and not vaudeville.

The increased demand made upon theatres displaying motion pictures for musical numbers has necessitated the employment of more musicians than in the past. The music provided for many of the pictures requires a great number of changes and many changes that must be made without the previous arrangement. In order to successfully conduct the orchestra, the leader must have some means of advising the various musicians of a

change without the old habit of striking the music stand with his baton or bow. This result is obtained by the use of small signal lamps located at each musician's stand with foot switches at the leader's platform. Further signalling apparatus is required between the various points in the theatre, some of which are taken care of by the house phone system, with instruments usually located on the stage, orchestra pit, box office, projection room, and manager's office. Additional signals are provided between the stage and orchestra, stage and projection room, stage and dressing rooms, stage and musician's room, orchestra and projection room, with return signals between these points. Buzzers have been used in many instances, but the fact that the house is quiet during the running of the picture, silent signals are now provided by means of colored lamps.

The attractiveness of the exterior illumination of the theatre, particularly in relation to the marquee and sign illumination, now received more attention than heretofore. Floodlighting of the exterior of the theatre during the night performances individualizes the location of the building and, with the attractive signs and brilliantly illuminated marquee, the results obtained are very satisfactory.

The mechanical equipment, namely the heating and ventilating, will be described in a later article.

Plans San Francisco Studio

The Edwin H. Flagge Scenic Company of Los Angeles, whose business has quadrupled in the past two or three years, due to the growth of the moving picture industry as well as to the increase in the number of theaters throughout the coast, has found it necessary to establish a studio in San Francisco. The company has leased a building at Fourteenth and Mission streets, and will have it equipped for painting scenery for moving picture studios, theaters and school auditoriums.

For Electricians

When a woman is sulky and will not speak—exciter.

If she gets too excited—controller.

If she talks too long—interrupter.

If she is willing to come half way—converter.

If she will come all of the way—receiver.

If she wants to go farther—conductor.

If she would go still farther—dispatcher.

If she wants to be an angel—transformer.

If you think she is unfaithful—detector.

If she is unfaithful—lever.

If she proves your fears are wrong—compensator.

If she makes a mistake—rectifier.

If she fumes and sputters—insulator.

The Contractor

BUILDING CONSTRUCTION, BRIDGES AND
ROAD WORK

Why Contractors Fail

By ORIN P. BAILEY, in A. G. C. Bulletin

WHAT kind of a man is the average, fairly successful contractor? First, he is a busy man. So busy in fact that he feels he has no time to attend contractors' meetings or to read trade literature. He has a general knowledge of a great many crafts and materials, where to obtain skilled labor, how to employ men to the best advantage, where to obtain materials and how to place them; he knows something about the railroad business, such as classifications, tracing shipments, demurrage and collection of claims; he knows how to have his books kept and something about cost accounting; he knows something of banking and how to borrow money; he knows something about law, as it relates especially to contracts and to liability for personal injury and property damage; he knows something of the various kinds of insurance, such as fire, sprinkler, public liability, employers' liability, and contingent liability.

In addition he usually is proficient in some building trade or has an engineering education.

He is interested in civic matters, gives freely of his time and money for the advancement of civic enterprises and activities.

He deals in large sums of money, assumes serious obligations and risks, is harassed by damage claims and has little time for vacations or recreation. He does not receive proper remuneration for his efforts and sel-

dom becomes permanently wealthy, his only reward being the love of constructing something useful and the satisfaction of seeing a number of nice structures substantially built as a monument to his life's activities.

WHY CONTRACTORS FAIL

The building industry is the second largest industry in this country, and according to government statistics taken from income tax returns, is one of the most hazardous as to profits.

Why, hazardous, and why the small net returns? Because the contractor does the following things:

1. Prepares estimates on plans and specifications prepared by more or less competent, but often impractical architects or engineers.

2. Bases his bid on this estimate in bidding against less competent estimators, and if his estimate is accurate and complete he loses the job to the man who forgot something or could not see it on the plan.

3. Uses sub-bids submitted on forms prepared by national associations of sub-contractors, containing limiting clauses which makes them worthless in case of a "show-down."

4. Uses the net price on cement in his estimate, assuming that all sacks will be returned and credit for them be given him, and that no defective sacks will be shipped him by the manufacturer and credit for them refused on their return. (All cement sacks eventually die on the contractor's hands, as cement manufacturers will not



A LIQUID FLOOR COVERING

For Outside and Inside Floors of Wood, Cement or Concrete

Standard Varnish Works

GENERAL OFFICE:

90 WEST STREET, NEW YORK

San Francisco Offices and Warehouse

55 STEVENSON STREET

When writing to Advertisers please mention this magazine.



BUILDING BUSINESS

CALIFORNIA'S OLDEST NATIONAL BANK HAS BEEN A VITAL FACTOR IN THE UPBUILDING OF SAN FRANCISCO AND THE ENTIRE WEST.

WHEN LAYING PLANS FOR THE FUTURE OF YOUR BUSINESS CONSULT THE OFFICERS OF THIS INSTITUTION

THE FIRST NATIONAL BANK OF SAN FRANCISCO

Affiliated with

FIRST FEDERAL TRUST COMPANY

Combined Resources \$60,473,521.88

receive and credit them unless they will stand another trip out.)

5. After bidding as low as he dares, he allows the architect to ask a few of the lower bidders and frequently all of the bidders to "figure a few changes"—an old game, which has cut the fair profit out of many a job, and is still being worked regularly. (Perhaps you don't enter these cut-throat competitions but the other fellow does; and you lose the job, the other fellow loses money and the owner wins, perhaps.)

6. Allows materials dealers and manufacturers to quote as low, or lower prices to the owner than they do to the contractor, and to sell direct to the owner when they see fit.

7. Signs a contract prepared by the architect for the protection of the interests of the architect's client, the contract usually providing that the interpretation of the plans and specifications by the architect shall be final, conclusive and binding "on both parties." (Strange to say such decisions usually stick the contractor and seldom secure payment to the contractor for the architect's mistakes.)

8. Furnishes a surety bond, if required, paying the bonding company 1 1/2 per cent. for it and gives them an indemnifying bond for their protection. The bond is frequently for the full amount of the contract and remains the same size after nine-tenths of the contract is completed.

9. Signs contracts containing a clause in which he agrees to employ union labor exclusively, knowing that union labor will make it hot for him as soon as it is known that his contract contains such a clause. (The man who sticks his head in the lion's mouth is wise compared to the contractor who signs such a contract, for there is a possibility that the lion will be seized with lockjaw and be unable to bite.)

10. Signs contracts with sub-contractors on blanks prepared by sub-contractors' associations. These contracts are prepared to protect the sub-contractor exclusively and the sub-contractor refuses to do business unless his contract is signed. Such contract forms usually contain clauses in which the

contractor agrees to do just the opposite to what he has agreed to in his contract with the owner. They contain clauses hanging the war tax on freight on the contractor, providing for free use of his hoisting equipment, and stipulating that he shall do all repairing after the sub-contractor gets through wrecking the building.

11. Furnishes lumber and nails for the plumber and heating contractor to use freely, (whoever heard of a plumber buying any nails?) except where some plumbers' associations refuse to allow their members to bid to a general contractor, insisting that they must bid direct to the owner for fear the contractor might make a spare dollar to repay him for the plumber's damage and thievery. (The general contractor should be in position to refuse to allow a plumber on the job except as a sub-contractor and thus under the contractor's control.)

12. Allows, sometimes, the architect or superintendent to cut his monthly estimate.

13. Allows the "party of the second part,"

TRANSMISSION EQUIPMENT

For Mill or Factory



Pulleys - - -	Shafting - - -	Gears - - - -
Hangers - - -	Bearings - - -	Take Ups - -
Sprockets - -	Clutches - - -	Chain Belts -
Floor Stands	Belt Tighteners	Rope Sheaves

Meeseco Short Center Drives

Meeseco & Gottfried Company

ENGINEERS AND MANUFACTURERS
CONVEYING, ELEVATING, SCREENING
AND MECHANICAL POWER TRANSMITTING
MACHINERY

SAN FRANCISCO 560 Mission Street	SEATTLE 553 First Avenue	PORTLAND 67 Front Street	LOS ANGELES San Pedro Street
-------------------------------------	-----------------------------	-----------------------------	---------------------------------

to fail to make payment to him of the full amount of the estimate due, on the day it is due, frequently allowing it to run into the next month.

14. Presents his final bill to the tender mercies of the architect who proceeds to carve it as he sees fit. (The contractor may howl a little, but he stands for the carving for his 10 or 15 per cent hold-back is up as a forfeit and he needs the money.)

15. After a basis of settlement is agreed on, he takes the owner's notes in final settlement, endorses the notes, and deposits them in the bank, thus cutting down his line of credit or his working capital by that much.

16. Contributes to all kinds of business associations, and if he gets in trouble, does not ask their help, being too proud to ask for help, or knowing the association would be too busy looking after the interests of organized lines of business to look after his troubles.

17. After the job is completed, the profit (if any) is so small that he dislikes to spend it for storage facilities and therefore he hauls his valuable equipment to the yard for thieves and rust to operate on until he needs it again.

THE PRESCRIPTION

Then what does the Contractor need?

1. Competition on projects confined to legitimate contractors only.

2. A code of ethics, lived up to by all competitors, and covering enough territory to be effective.

3. Some method of making sure that all his competitors have full quantities in their estimates, for a contractor may make a complete and correct estimate himself, but if any of his competitors have failed to take off complete quantities of material he is handicapped that much in the competition.

4. Proper, fair and safe contracts with owners on forms prepared by contractors.

5. Proper, fair and safe contractors with sub-contractors on forms prepared by contractors.

6. A method of requiring manufacturers and material dealers to quote preferential prices to contractors, or to sell only through contractors.

7. A healthy competition in materials.

8. A plentiful supply of competent mechanics and enough apprentices to assure a future supply of mechanics.

Big Manufacturing Plant

The Bowen Motor Car Co. of St. Louis, Mo., through its vice-president, A. D. Bowen, now in California, has taken option on 87 acres in the northern section of Richmond as a site for the company's Pacific Coast plant. The company manufactures gasoline motor-propelled street cars. It is proposed to erect a unit of 100 working men's cottages, in addition to the factory, cottages to be of the bungalow type, and will cost \$2500 each.



Throop College, Pasadena, Calif.
Myston Hunt & Elmer Grey
Architects, Los Angeles, Calif.

Beauty that Protects

Bay State is popular with architects for two reasons—it carries out their ideas of a beautiful finish, and it protects the buildings they create.

Brick, cement, and stucco walls become damp-proof, rain-proof, and wear-proof when coated with Bay State Brick and Cement Coating. Write for samples in white and colors, and Booklet No. 43

WADSWORTH, HOWLAND & CO., Inc.
Paint and Varnish Makers
Boston, Mass.

JAMES HAMBLY & SON, Repr.
304 Crocker St. 268 Market St.
Los Angeles San Francisco

BAY STATE
Brick and Cement Coating

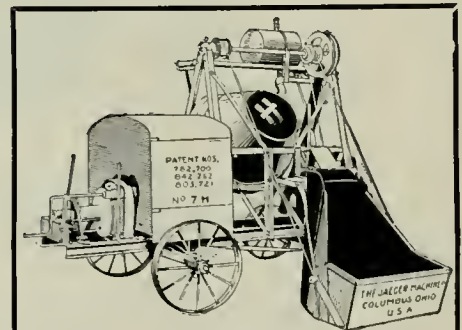

NOT ONLY MIXERS

but a full line of nationally-known equipment, as well.

We have prepared for a brisk building season.

“Get it from BACON”

Edward R. Bacon Company

51 Minna St., San Francisco

165 E. Jefferson St.
Los Angeles

When writing to Advertisers please mention this magazine.

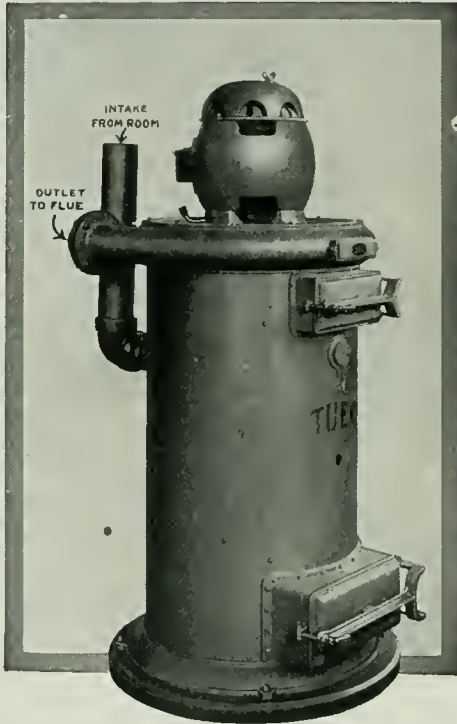

TUEC STATIONARY CLEANER

THE cleaner that reduces building maintenance expense by keeping floors, walls, stairways, merchandise and other stocks, carpets, furniture and furnishings free from dust and dirt. No other cleaning device or dust removal method is so thorough, efficient, and economical. Investigate yourself and invite your client to do so. Write for our free catalog and full information.

THE UNITED ELECTRIC CO.
CANTON, OHIO.

Canadian Plant: Toronto, Ont.

California Distributors

S. F. COMPRESSED AIR CLEANING CO.
397 Sutter Street, San Francisco

BARKER BROS.
724 S. Broadway, Los Angeles



How Do Customers Judge Your Firm?

JUST as the manner and appearance of your employees command respect or disapproval from outsiders, so your office equipment tells the visitor whether or not to expect an orderly, reliable and established business organization.

Accustomed as you are to your surroundings, just try for a moment to see them through the critical eyes of a business prospect. Are you satisfied or does it leave you with some misgivings?

"Good people"—so goes the silent message from office to caller when you are equipped with Globe-Wernicke Filing Cases, Fire Proof Safes, Bookcases and the proper kind of desk accessories.

Globe-Wernicke office fixtures, steel or wood, besides comprising the most complete line of office equipment manufactured, are outstandingly the best from a standpoint of design and utility.

Perhaps the appearance of YOUR office could be improved. A bookcase added, or a modern filing case for your records may help your particular business to run smoothly and assist in favorably impressing the visiting "outsiders."

The H. S. Crocker Company maintains a complete stock of Globe-Wernicke fixtures ready for your inspection.

Send today for catalogue

H. S. CROCKER CO., INC.

565-571 Market Street, San Francisco

Los Angeles

1444 Broadway, Oakland

Sacramento

Completes Satisfactory Contract

Mr. Jas. L. McLaughlin, San Francisco contractor, recently completed his contract on the new Chico high school building, Messrs. Woollett and Lamb, architects. The Board of Education announced that it was very well pleased with the work, and the city treasurer was instructed to pay Mr. McLaughlin the balance due on the contract, amounting to about \$60,000. The total amount of the contract was \$373,313, and included brick walls, concrete floors, tile partitions and roof. The building is one of the largest high school structures on the Pacific Coast, its two stories covering approximately 70,000 square feet. Mr. McLaughlin has offered to finish the inside of the structure for \$115,000, or under, according to cost of materials and labor at the time the contract is signed. The work yet to be done includes interior finish, plastering, painting, tile work, blackboards, clock system, lighting fixtures, shades, etc.

Referring to completion of the contract, the Chico Daily Enterprise, under date of May 10th, said:

Contractor McLaughlin must be credited with having handled a very difficult contract running through an extremely trying period with the utmost ability and liberality. By fairness and tact, as well as by firmness and skill he has earned the good will and good opinion of every member of the school board and of all who are acquainted with the character of the work and the obstacles overcome in its accomplishment.

Columbia School of Architecture

The experiment in training students of architecture with three dimensional models has proved so successful in the regular work of the Columbia School of Architecture that courses in technique of model making will be given under the summer session, which begins on July 5 and continues for six weeks and for which an attendance of more than 12,000 students is expected. Harold V. Walsh, instructor in architecture at Columbia, will give the course, which is one of a large number of summer courses in architecture.

Courses in shades and shadows, perspective, pencil drawing, advanced design, water color drawing, charcoal drawing, elementary design, elements of design including the application of orders, domestic architecture, antique and life drawing, and a course in the fundamental technique of architectural drafting as practiced in the average office are among those offered for the summer semester. The courses are also open to all qualified students without examination.

San Jose Contractor's Hard Luck

"Jack" Guilbert, a San Jose cement contractor, feels that fate is against him. Mr. Guilbert recently was awarded the contract for erecting some new electroliters in front of the side entrance to the Montgomery hotel on West San Antonio street. His men drilled a hole at the edge of the sidewalk and then began pouring cement into it. When they had poured a half dozen sacks Guilbert began to think the hole had no bottom and made an investigation. He found the drillers had cut into the basement of the hotel and that the cement had fallen onto a stock of hats stored there. Of course it was up to the contractor to make good the loss. It is a safe prediction his profits on the job were materially reduced.—San Jose Mercury.

Will Design Napa Schools

By an error it was announced in this magazine last month that Mr. William H. Weeks of San Francisco had been appointed architect of new schools to be erected from the proceeds of a bond issue at Santa Rosa. The city was Napa, not Santa Rosa. And Mr. Weeks, by the way, designed the new Colusa grammar school, a picture of which was shown in the advertisement of the W. P. Fuller Company last month and credited to Mr. J. S. Gould.

\$800,000 Apartment House

Mr. Frank Meline is preparing plans for a seven-story Class "A" reinforced concrete apartment house at Wilshire boulevard and Catalina street, Los Angeles, for himself and associates at an estimated cost of \$800,000.

Class A Building

Mr. Aleck E. Curlett, 518 Merchants' National Bank building, Los Angeles, has completed plans for a six-story Class A office and factory building to be erected at San Pedro and Twelfth streets, Los Angeles, for Cohen-Goldwater Co.

Office Phone
West 2429

Residence Phone
Fillmore 1856

J. F. Wayne & Co.

Interior Decorating

1914 FILLMORE STREET
SAN FRANCISCO

DEPENDABILITY

CARVED natural stone, when you wish to incorporate it in your design, often proves prohibitive from the standpoint of cost.

Such designs can usually be reproduced—at far more moderate cost—in enduring cast stone, made with **ATLAS-WHITE** Portland Cement. Its use is graphically described in our book, “Cast Stone.” Shall we send you a copy?

THE ATLAS PORTLAND CEMENT
COMPANY

New York Boston Philadelphia Birmingham
Chicago Dayton Des Moines St. Louis

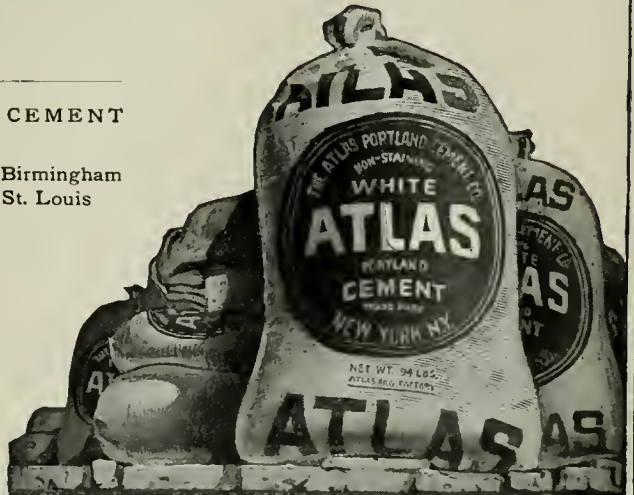

ATLAS WHITE

Personal

MR. EDWARD G. GARDEN, architect, formerly in the Jas. Flood building San Francisco, is now associated with Mr. J. Martyn Haenke, with offices at 809 Balboa building. The firm has several large projects on the boards.

MR. WILLIAM KNOWLES, Oakland and San Francisco architect, has been appointed a member of the new Oakland City Planning Commission.

MR. WHITNEY WARREN, architect, of New York, has been selected by the Belgian-French committee in charge of the restoration of the destroyed University of Louvain to restore that great Belgian seat of learning.

Oakland Depot and Office Building

A ten-story class "A" office building and interurban depot will be erected at Thirteenth and Franklin streets, Oakland, from plans by Bliss & Faville, Balboa building, San Francisco. The project is being promoted by the Oakland Terminal Building Corporation, which will spend \$6,500,000 on the building. Incorporation papers, it is announced, will be filed at Sacramento shortly. Besides offices, the building will contain stores arranged in an arcade, a large waiting room, etc. Exterior of the building will be of pressed brick and terra cotta.

Theater For Madera

Ruegg Bros., Pacific building, San Francisco, probably will be awarded a contract for the construction of a class "A" store and theater building at Madera for Mr. A. C. Chamberlain of that city, for \$94,000. Mr. A. W. Cornelius, Merchants' National Bank building, San Francisco, is the architect.

Concrete Subway to Be Built

The State Railroad Commission has authorized the construction of a concrete subway under the Southern Pacific railroad tracks at the west end of Seventh street, Oakland, in connection with the new Six Minute Ferry Company's automobile service. The estimated cost of the subway is \$400,000.

To Erect Loft Building

Messrs. MacGruer & Simpson, the San Francisco plastering contractors, have had plans prepared by Mr. William H. Crim, Jr., for a two-story reinforced concrete loft building, 50x155, on Howard street, west of Fourth. Contracts for the erection of the building have been awarded.



Largest Elevated Water Tank in California

The inner surfaces of this tank, located at Merced, and the property of that city, are coated with

BITURINE ENAMEL

The outer tank surfaces and supporting structure are coated with

BITURINE SOLUTION

In San Francisco and Oakland over 200 Water Tanks have been treated with BITURINE.

Manufactured and Applied by

Hill, Hubbell & Co.

No. 1 Drumm Street,
SAN FRANCISCO

Los Angeles

Seattle

New York

When writing to Advertisers please mention
this magazine.

(SONNEBORN PRODUCTS)

Grind-Proof *and* Dust-Free Concrete Floors!

DUSTING WEARING CONCRETE FLOORS
ARE A THING OF THE PAST WHEREVER
ARCHITECTS HAVE SPECIFIED

Lapidolith

THIS liquid chemical has been flushed on 70,000,000 square feet of concrete floors old and new during the last two years alone. These lapidolized floors are now wearproof and dust-proof, because Lapidolith has completed the hydration of the Portland Cement and this Concrete is harder than granite.

Have you seen the results secured by the Lapidolith treatment? If not, let us refer you to a lapidolized floor near you. Thereafter you will specify Lapidolith on your old and new concrete work.

SONNEBORN PRODUCTS:

Cemcoat

the durable Mill White, Washable, of exceptional covering capacity, Gloss, Flat and Egg-shell, also all colors.

Lignophol

the modern wood preservative gives new life to old or new wooden floors.

Write for sample, literature and specification form

*Concrete for Permanence
Lapidolith for Dustlessness*

L. SONNEBORN SONS, Inc.

San Francisco

Los Angeles

Seattle

(SONNEBORN)



The
ST. FRANCIS
One of the world's great hotels
Facing Union Square
SAN FRANCISCO CALIFORNIA

EXPRESSES MOST PLEASANTLY THE HOSPITALITY AND ANIMATION THAT ARE CHARACTERISTIC OF SAN FRANCISCO

Thos. J. Coleman.
Manager

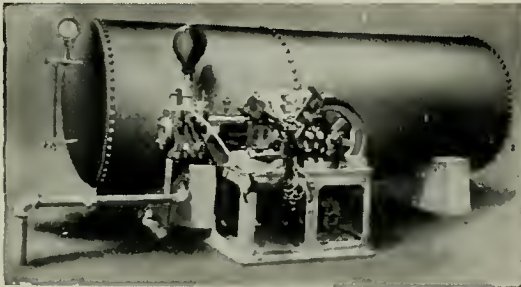

Kewanee Water System

Maintain your own Plant.
Small Operating Expense.
A Perfect Water Supply to
Country Homes, Hotels
and Parks.

Simonds Machinery Co.

117-121 Montgomery Street
SAN FRANCISCO
Phone Kearny 1457

Tropico Potteries, Under New Management, Has Progressive Ideas for Business Expansion

ARCHITECTS and builders throughout the Pacific Coast will learn with considerable satisfaction that the Tropico Potteries in Southern California has been incorporated and financed by an issue of \$300,000 closed first mortgage 8 per cent bonds. With the reorganization there has been effected some important changes in management, and the latter has already commenced to broaden the company's field of production by adding to the plant's equipment and manufacturing facilities. Clay products, such as vitrified pipe, architectural terra cotta and faience tile will be made under the direction of expert advice, and the company will not confine its business to local territory, but will seek orders throughout the Western States.

An office building and two new dormitories have been constructed at the plant, and considerable new machinery has been installed. The physical property of the Tropico Potteries, Inc., consists of thirty-seven acres near the north city limits, of which approximately five acres are under roof; also 140 acres of clay beds at Elsinore, about seventy-five miles southeast of Los Angeles, on the Santa Fe railroad; 120 acres of clay in the Temescal Canyon, a few miles from Corona and large talcum deposits, just across the Nevada line.

The industrial plant of the Tropico Potteries, Inc., consists of twenty-one kilns, with the necessary complement of clay houses, grinders, mixers, molding and drying rooms and storage, office and designing quarters for the engineering and clerical staffs. The kiln capacity with the present equipment is 1100 tons of finished product monthly and the plant is working to full capacity.

Until the present time the production has been confined to vitrified sewer pipe of all diameters, to architectural terra cotta and ornamental faience tiles, but under the reorganization plans for additions to these lines are contemplated as well as increased production in the established commodities.

The Tropico Potteries, Inc., took over the properties of the Pacific Minerals and Chemical Company on January 1, 1921, and immediately took steps to secure a managerial personnel that would be able to cope with the greatly increased market and carry out the development projects of the financiers behind the reorganization.

Complete motorization of the plant at Glendale is now well under way, supplanting steam for electricity. The grinding and preparing of all clays, manu-

facturing of sewer pipe, tile, water pipe, flue lining, chimney pipe, etc., and the operation of all driers, presses, elevators, conveyors and machine shop will be carried on with electrical equipment. With the installation of the new power system, it is estimated by the management that a saving of approximately \$1000 a month in operating expense will result and that production will be increased almost twofold.

The recent installation of hot air driers in the press rooms is another step forward for the company in the manufacture of architectural terra cotta. The speeding up of the drying over the old method will permit of using only half the number of moulds per man as were formerly necessary and result in considerable saving in floor space. In the drying room a humidity drier giving a direct heat is being installed, which will increase the output of terra cotta about four times the present capacity. It is stated that a savings of several hundred dollars per month will result in operating the humidity drier as against the former steam heat method.

The Tropico Potteries, Inc., already have penetrated the East with Southern California building materials, being engaged in the construction of Cochise Hall, a men's dormitory for the University of Arizona, at Tucson, and of the State National Bank at El Paso. The beautiful ecclesiastical designs in terra cotta for the Wilshire Presbyterian church are from this pottery and numerous examples of their product are evident in such local architecture as the Merchants' National Bank, the Robinson store, the Corporation building, the new Ross Campbell building, the Arnold garage and automobile stores, the Stowell hotel and other modern structures of Los Angeles. All the miles of sewer pipe for the marine base at San Diego were the product of the Tropico Potteries.

The reorganized and refinanced company is officered by Messrs. B. M. Wotkyns, president; Fred B. Ortman, vice-president and general manager, and E. M. Davids, secretary-treasurer. General offices are maintained at the plant, with city offices in the Security building, Los Angeles.

\$30,000 San Francisco Residence

Mr. Milton Latham, 454 Montgomery street, San Francisco, has completed plans for a \$30,000 house of twelve rooms and four baths to be erected on Pacific avenue, San Francisco, for Mrs. Estelle Lippitt.

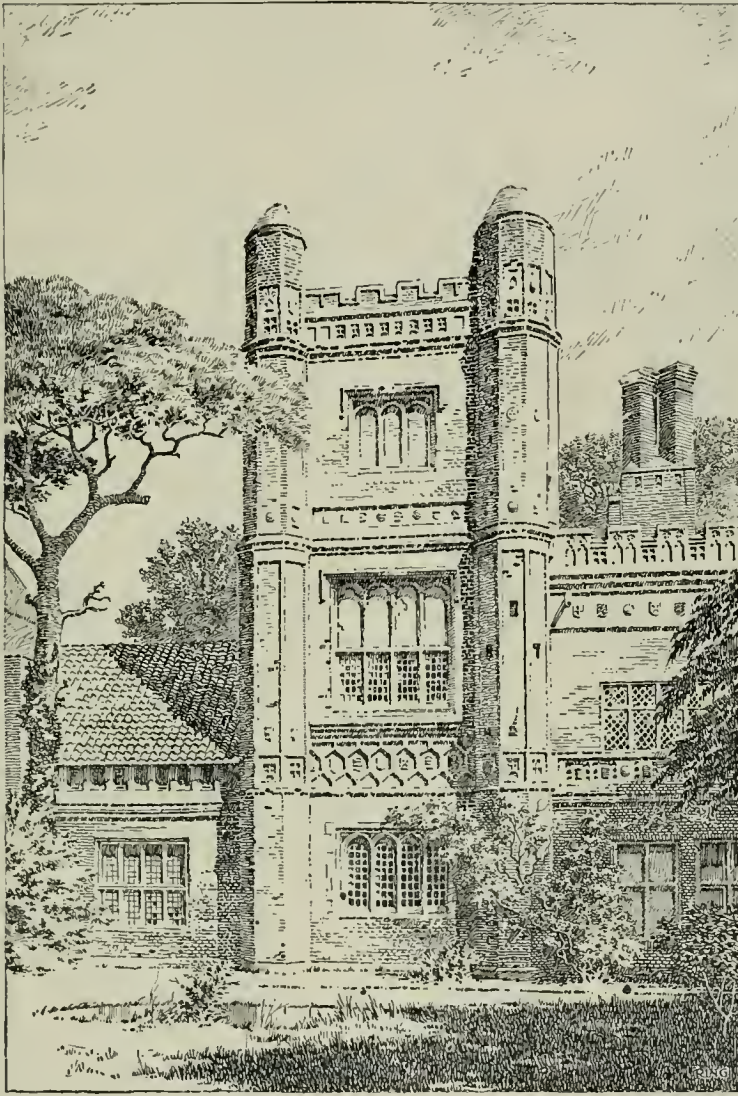

Manor House,
East Barsham,
England



THE CHARM and distinction of English country houses has drawn many an architect to the British Isles for artistic motives. Their stateliness, their substantiality, their splendid details, the beauty and mellowness of their brick walls, arouse universal admiration.

The natural beauty and adaptability of brick has, in the past decade, been supplemented by American face brick manufacturers with

a wide variety of color tones and textures.

Through mixtures of clays and shales, by the invention of new devices for cutting the brick, and by new methods of setting and firing the kilns, the artistic possibilities of face brick are being constantly extended. Any member of this association is at all times ready to discuss the architect's face brick problems with him; and to co-operate with him to the fullest extent.

AMERICAN FACE BRICK ASSOCIATION

1159 WESTMINSTER BUILDING · CHICAGO, ILLINOIS

Use SCHROEDER Direct-Flush Valves

The only All Brass Flush Valve for Toilets on the Market

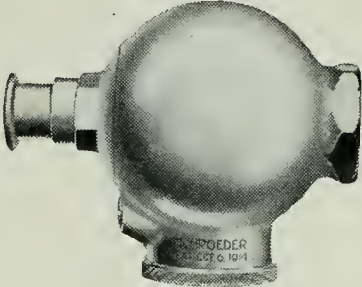

MADE IN FOUR SIZES
 $\frac{1}{2}$ in. $\frac{3}{4}$ in. 1 in. $1\frac{1}{4}$ in.

Unexcelled Simplicity of Construction

- | | |
|-------------------------|--|
| Eliminates Repair Bills | No By-Passes |
| Eliminates Water Waste | No Rubber or Leather Parts |
| Eliminates Corrosion | No Complicated Parts to get out of order |
| Eliminates Hammer | |

Easily and quickly installed

Unequaled for Efficiency and Economy

Write for descriptive booklet

The New Stock Exchange Building (Morgan, Walls & Morgan, Architects) on Spring Street, between 6th and 7th Streets, Los Angeles (a 13-story office building of the very latest type) is equipped throughout with Schroeder Valves. We have many other installations that have stood the test of time and hard usage.

MADE BY

STANDARD METALS MANUFACTURING CO.

1300-1302 N. Main St. Phone 66864 Los Angeles, Calif.

WaterSavR FLUSHING VALVE

Non-Clogging, Self-Cleaning, Controlling By-Pass

NOTE

Controlling water is in two enclosed chambers and separated from the flushing water.

NOTE

Controlling by-pass connects two enclosed chambers B. and C. It cannot be clogged by dirt in the flushing water.

**OPERATES
 EQUALLY AS
 WELL WITH
 DIRTY
 AS WITH
 CLEAN WATER**

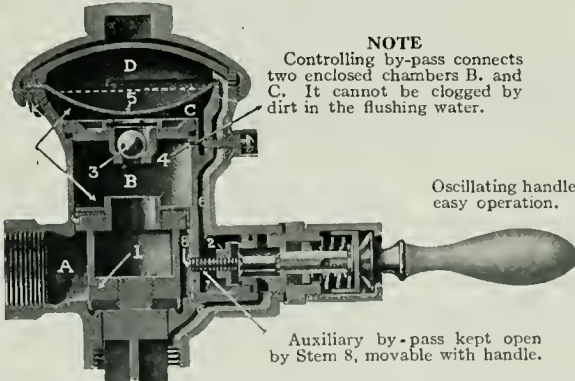

Oscillating handle easy operation.

Auxiliary by-pass kept open by Stem S, movable with handle.

The by-pass is positively and automatically kept open and free of obstruction and cannot become clogged no matter how dirty the water may be.

Patented March 18, 1919

NATIONAL VALVE COMPANY

Phone Douglas 5093

23-25 MINNA STREET, SAN FRANCISCO

The Heart of the Kitchen

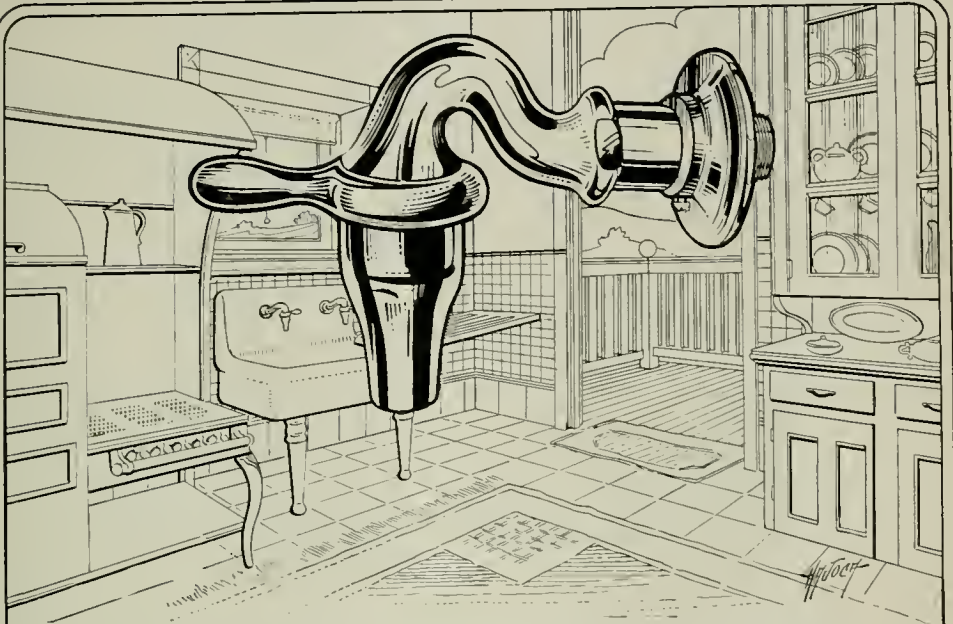

ONE of the most prominent Architect firms in San Francisco, and well known throughout the country, without solicitation on our part, wrote us as follows:

"We not only specify but insist on the plumber furnishing HAJOCA 'Quick' Faucets for all sinks in buildings constructed by us.

We consider everything from the rapid flowing stream to the simplicity of re-washing a delight to the user."

HAJOCA "Quick" Faucets are used not only on kitchen sinks, but shop sinks, laundry trays and factory wash sinks.

Many Architects, like the firm above quoted are standardizing their specifications on HAJOCA "Quick" Faucets.



HAINES, JONES & CADBURY Co.

MAKERS OF PLUMBING SUPPLIES

851 9 FOLSOM STREET, SAN FRANCISCO

PHILADELPHIA-NEW YORK-RICHMOND, VA.-SAVANNAH



IRON ^{AND} STEEL PRODUCTS

WAREHOUSE AND
MILL SHIPMENTS

STEEL BARS

for

CONCRETE
REINFORCING
FURNISHED AND
INSTALLED

EDW. L. SOULE' CO.
SAN FRANCISCO



SUTTER
2821

RIALTO
BUILDING

SERVICE

TESTING
INSPECTION
CONSULTATION
PRODUCTION

Structural and Engineering
Materials



Robert W. Hunt & Co.
Engineers

Chemical and Physical
Testing Laboratories

New York Chicago Pittsburgh
St. Louis San Francisco Mexico City
London Montreal

Heating and Ventilation

CONSULTING
Mechanical

ENGINEERS
Structural

Machine Design

Industrial Plant Design and
Equipment

376 Monadnock Bldg.
Phone Douglas 2945

San Francisco
California

Superintendent of Construction
Specifications and Estimates

JOHN E. HAMILTON

Present Cost of Building Materials*

With Labor Wage Scale, Bonds, Etc.

THESE quotations are based on reliable information furnished by San Francisco material houses. Date of quotations, May 20, 1921.

All prices f. o. b. cars San Francisco or Oakland. For country work add freight and cartage to prices given.

American Institute of Architects' Fees

New work—6 per cent minimum basis.

Alterations—7 to 10 per cent as a minimum basis.

High class residence work—10 per cent as a minimum.

Bond—1½% amount of contract.

Brickwork—

Common, \$40.00 per 1000 laid.

Face, \$90.00 per 1000 laid.

Common, f. o. b. cars, \$16.50 plus cartage.

Face, f. o. b. cars, \$55.00 per 1000, carload lots.

HOLLOW TILE FIREPROOFING

12x12x3 in., 10¼c. per square foot.

12x12x4 in., 11¾c. per square foot.

12x12x6 in., 16¼c. per square foot.

Hod carriers, \$8.00 per day.

Bricklayers, \$10.00 per day.

Line—\$3.25 per bbl.; carload, \$2.75 per bbl.

Composition Floors—30c. per sq. ft.

Concrete Work (material at San Francisco bunkers)—

No. 3 rock.....\$2.25 per yd.

No. 4 rock..... 2.25 per yd.

Niles pea gravel..... 3.25 per yd.

Niles gravel..... 2.50 per yd.

Niles top gravel..... 3.00 per yd.

City gravel..... 2.25 per yd.

River sand..... 1.50 per yd.

Bank sand..... 1.00 per yd.

SAND

Del Monte, \$1.25 to \$1.50 per ton.

Fan Shell Beach, \$2.50 to \$3.00 per ton.

Car lots, f. o. b. Lake Majella.

Cement (f. o. b. cars).....\$3.69 per bbl.

Rebate for sacks, 15c each.

Atlas "White"..... \$12.60 per bbl.

Medusa cement.....\$12.60 per bbl.

Forms.....\$25.00 per M

Wage—

Laborers.....\$7.05 per day

Concrete workers..... 7.50 per day

Cement finishers..... 8.35 per day

Dampproofing—

Two-coat work, 25c per yard.

Membrane waterproofing—4 layers of P.

B. saturated felt, \$6.00 per square.

Hot coating work, \$2.00 per square.

WAGE—Roofers, \$9.00 per day.

Electric Wiring—\$8.00 to \$12.00 per outlet for conduit work (including switches).

WAGE—Electricians, \$10 and \$10.50 per day.

Knob and tube average \$4.50 to \$6.00 per outlet.

Elevators—

Prices vary according to capacity speed and type.

Consult elevator companies.

Excavation—

\$1.75 per yard.

Teams, \$10.00 per day.

Trucks, \$28.50 to \$38.50 per day.

Above figures are an average without water.

Steam shovel work in large quantities, less;

hard material, such as rock, will run considerably more.

Fire Escapes—

Ten-foot balcony, with stairs, \$100.00 per balcony.

Glass—(Consult with manufacturers.)

21 ounce, 20c per square foot.

Plate, \$1.40 per square foot.

Art, \$1.00 up per square foot.

Wire (for skylights), 44c per square foot.

Obscure glass, 28c per square foot.

Note.—Add extra for setting.

WAGE—Glaziers, \$7.85 per day.

Heating—

Average, \$2.00 per sq. ft. of radiation, according to conditions.

WAGE—Steamfitters, \$10.00 per day.

Iron—

Cost of ornamental iron, cast iron, etc., depends on design.

Lumber—(Prices delivered to bldg. site)

Common, \$34 per M (average).

Com'n O. P. (select), \$45 per M (average)

Flooring—

1x3 No. 1.....\$77.00 per 1000

1x3 No. 2..... 72.00 per 1000

1x4 No. 1..... 73.00 per 1000

1x4 No. 2..... 70.00 per 1000

1x4 No. 3..... 47.00 per 1000

1x6 No. 2 and better..... 73.00 per 1000

1¼x4 and 6 No. 2..... 75.00 per 1000

Slash grain, 1x4 No. 2..... 48.00 per 1000

Slash grain, 1x4 No. 3..... 39.00 per 1000

No. 1 common run to

T. & G. 35.00 per 1000

Lath..... 6.50 per 1000

Shingles—(Add cartage to prices quoted)

Redwood, No. 1.....\$1.00 per bdle.

No. 2..... .90 per bdle.

Red Cedar..... 1.10 per bdle.

Hardwood Floors—

Maple floor (laid and finished), 30c per foot.

Factory grade floors (laid and finished), 23c per foot.

Oak (quartered, finished), 40c per foot.

¾ Oak (clear), 30c per foot (plain).

¾ Oak (select), 28c per foot (plain).

¾ Oak, quartered, sawed, clear, 35c.

WAGE—Floor layers, \$10.00 per day.

Hardwood Floors (not laid)— Per M ft.

5/16x2" sq. edge Clear quartered oak.....\$220.00

Select quartered oak..... 162.50

Clear plain oak..... 147.50

Select plain oak..... 127.50

13/16x2¼" face Clear quartered oak..... 292.50

Select quartered oak..... 200.00

Clear plain oak..... 200.00

Select plain oak..... 180.00

Clear maple..... 160.00

Clear maple—white..... 250.00



Build with Armco Iron-- Repair with It

If the roof of your building needs repairing, repair it so it won't need attention again for many years. MAKE IT A GALVANIZED ARMCO IRON ROOF. Use corrugated sheets of galvanized Armco Iron for the siding.

If you want your grain bins, silos, tanks and troughs, warehouses, sheds, etc., to last, see that these also are made of Armco Iron.

This wonderfully pure and even iron takes and holds a coat of galvanizing better than any other metal. The galvanizing adheres closely and because it is fused with the base metal does not crack or peel off.

Every product manufactured of galvanized sheet metal—plain or corrugated—will last longer if made of Armco Iron, for Armco Iron resists rust.

The American Rolling Mill Co.

Middletown, Ohio

Licensed Manufacturers under Patents granted to the International Metal Products Company

Pacific Coast Sales Office—Tenth and Bryant Streets, San Francisco; other Branch Offices in New York, Chicago, Pittsburgh, Cleveland, Detroit, St. Louis, Cincinnati, Atlanta, Washington, D. C., and Buffalo.



An Ample Stock of Armco Iron is carried at San Francisco Warehouse.

WILSON

Folding Partitions

*for Schools, Clubs, Churches, Hotels, Y. M. C. A. Buildings or
any building where a division of space is required*

Easy to Operate

Not Accordion

No Hangers

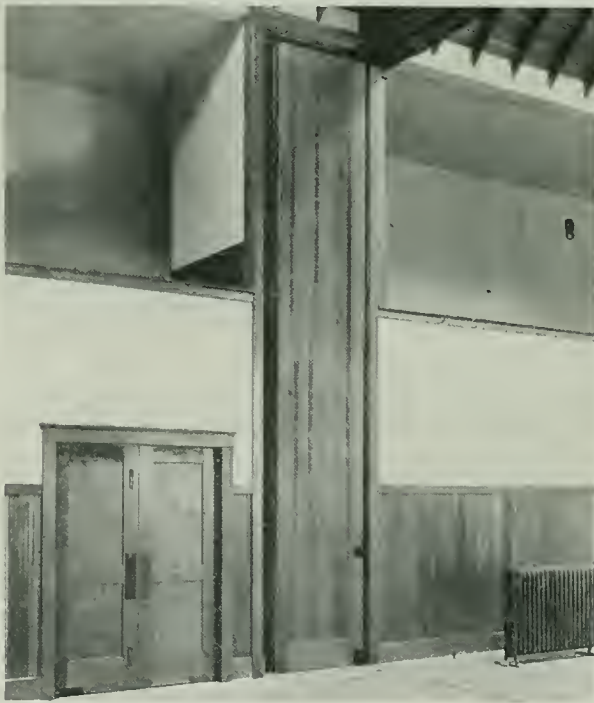

Illustration of
Wilson Folding
Partition as in-
stalled in Frank-
lin High School
gymnasium, Los
Angeles; Archi-
tect, Herbert C.
Howard, Los An-
geles.

PARTITION FOLDED IN POCKET

MANUFACTURED BY

The J. G. Wilson Corporation

Pacific Coast Office

621 N. Broadway Phone 67189 Los Angeles, Cal.

Also Manufacturers of Diffuselite Blinds and Awnings, Rolling Partitions,
Rolling Steel Doors, School Wardrobes

Waterhouse-Wilcox Co., San Francisco; Theo. F. Snyder, San Diego; F. W.
Farrington & Co., Portland; S. W. R. Dally, Seattle; Hawley-Richardson-Wil-
liams Co., Salt Lake City; Walter Dubree, Phoenix; Grace Brothers, Honolulu.

WILSON

Folding Partitions

*for Schools, Clubs, Churches, Hotels, Y. M. C. A. Buildings or
any building where a division of space is required*

Easy to Operate

Not Accordion

No Hangers



THIS PARTITION 60' 0" WIDE x 20' 0" HIGH

Equipped with Wilson spring jambs allowing for expansion or contraction of doors. All doors are flush gymnasium type. Wilson folding partitions are standard in most all large cities for their schools.

MANUFACTURED BY

The J. G. Wilson Corporation

Pacific Coast Office

621 N. Broadway Phone 67189 Los Angeles, Cal.

Also Manufacturers of Diffuselite Blinds and Awnings, Rolling Partitions,
Rolling Steel Doors, School Wardrobes

Waterhouse-Wilcox Co., San Francisco; Theo. F. Snyder, San Diego; F. W.
Farrington & Co., Portland; S. W. R. Dally, Seattle; Hawley-Richardson-Wil-
liams Co., Salt Lake City; Walter Dubree, Phoenix; Grace Brothers, Honolulu.

The Granite Work on Eldorado County Courthouse; National Bank of D. O. Mills, Sacramento;—
and Sen. Nixon Mausoleum, Reno, WAS FURNISHED BY

CALIFORNIA GRANITE COMPANY

Phone Sutter 2646

STONE CONTRACTORS

Builders' Exchange, San Francisco
Quarries, Rocklin and Porterville

Main Office, Rocklin, Placer Co., Cal.
Telephone Main 82

DUNN SPRAY METHOD OF PAINTING

Saves Time, Labor and Material. Will outwear paint applied by other methods.
→ **RONFLE Special Paints for Specific Purposes Used Unless Otherwise Specified.**

PACIFIC PAINTING AND ROOFING COMPANY

G. D. NEWTON, Manager

PACIFIC BLDG., SAN FRANCISCO. 388 - 12th St., OAKLAND

CHAS. STOCKHOLM & SONS

GENERAL CONTRACTORS

849 MONADNOCK BUILDING Phone D UGLAS 4657 SAN FRANCISCO

M. E. RYAN

Electrical Contractor and Dealer

520 Clunie Building, San Francisco

Phone Garfield 3159

JOHN M. BARTLETT

GENERAL CONTRACTOR

Office
357 - 12th ST., OAKLAND

Phone Lakeside 6750
Res. Phone Berkeley 6884W

E. T. LEITER & SONS

BUILDING CONSTRUCTION

412 CALL-POST BUILDING Phone SUTTER 1980 SAN FRANCISCO

Shop and Compare—that's the only true test
of values.

Furnishings for the home of distinctive style are
featured in this shop at prices that will bear the
strictest comparison.

Furniture Draperies Floor Coverings Interior Decorations

John Breunler Co.
of San Francisco

281 GEARY STREET

SAMSON SPOT SASH CORD

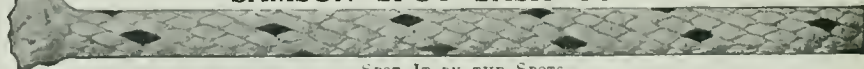

SPOT IT BY THE SPOTS

Made of extra quality cotton yarn, firmly braided and smoothly finished. Carefully inspected and
guaranteed free from all imperfections of braid and finish. → Can be distinguished at a glance
by our trade-mark, the Colored Spots. Send for catalogue and samples.

Pacific Coast Agent, JOHN T. ROWNTREE, Inc., San Francisco and Los Angeles, Cal.

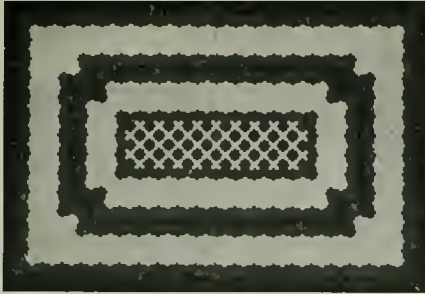

INTERLOCKING RUBBER TILING

material that is sure to give satisfaction. **Twenty tons installed in the Standard Oil Building, San Francisco.**
Stock on hand for immediate delivery.

The Elevator Floor

whether in Office Building, Hotel or Department Store, is subjected to a great deal of wear and tear.

— SPECIFY —

INTERLOCKING RUBBER TILING

and you've provided your client's building with a Durable, Economical, Practical,



New York Belting and Packing Co.

NEW YORK

San Francisco Branch 519 MISSION ST. Phone Douglas 1837

Small booklet of designs mailed on request.

Look for this
Trademark



And if it's there don't worry any more about your Valves and Fittings



Specify and insist upon having

**The Kelly & Jones Co.
Valves and Fittings**

**Byers Genuine
Wrought Iron Pipe
Republic Steel Pipe**

Complete Line of Plumbing Supplies
Large Stocks for Prompt Delivery
Catalogue on request

California Steam & Plumbing Supply Co.

671-679 Fifth Street, Corner Bluxome
SAN FRANCISCO, CALIFORNIA

**FOR MODERN
STORE FRONTS**

Plummer's Disappearing Awnings

Are constructed with no outside attachments below awning recess. All mechanical parts entirely concealed. Send for Architects' Sheet showing specifications for recess construction, etc.

W. A. PLUMMER MFG. CO., 35-37 Front Street, San Francisco

JOHN TRAYNOR

CHARLES HARCOURT

OCEAN SHORE IRON WORKS

Manufacturers of Boilers, Steel Tanks, Steel Plate Specialties.
Dealers in Boilers, Tanks, Pumps, Engines, Machinery, Etc.

We offer the following equipment for speedy disposal, subject to prior sale: 2—80-h. p. Horizontal Tubular Boilers, butt-strapped, 120 lb working pressure; 2—100 h. p. Heine Safety Water Tube Boilers, 130 lb W. P. 10—250 h. p. Marine Heine Cross Drum Water Tube Boilers; new; for marine or land use; 175 lb W. P. Prices on application. Send us your inquiries.

Office and Works:
550 EIGHTH STREET

SAN FRANCISCO, CAL.
Telephones: Market 462-463

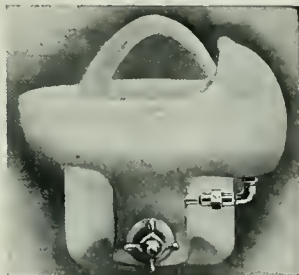

Model No. 7A.

NO GERMS HERE

HAWS IMPROVED SANITARY DRINKING FAUCET eliminates all possibility of contracting disease from dirty bulbs or unsanitary bowls. Provided with an overhead cowl, the drinker's lips never touch the source of supply. A slanting stream throws the water from right to left and away from the bubbler, instead of straight up to fall back over the fountain head. Recommended for Schools and Public Playgrounds. A type used extensively by the U. S. Government. Manufactured by

Haws Sanitary Drinking Faucet Co., Inc.
1808 Harmon Street, Berkeley Phone Piedmont 3742

GENUINE PRESERVATIVE PAINT FOR EVERY USE

Moran's Patented Preservative Paints and Compounds

will positively preserve iron, steel, concrete, roofs, piles, poles, railroad ties, and all wood or metal surfaces above or below earth or water.

MORAN'S PATENTED ANTI-FOULING AND HULL PAINT

Quality Products proven by the test of time

COMMERCIAL EXPORT & IMPORT CO., Inc.

SOLE REPRESENTATIVES

BALBOA BLDG., San Francisco. Tel. Sutter 6833

Branches in Los Angeles, Salt Lake City, Pittsburgh, Honolulu, Australia, New Zealand

GENERAL BOILERS COMPANY

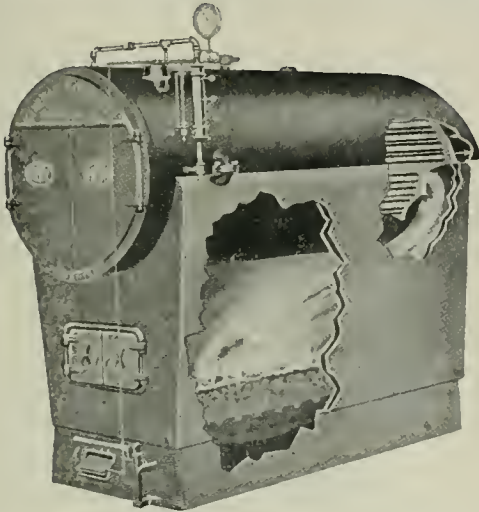

General Office and Plant:
WAUKEGAN, ILLS.

Manufacturers of
"PACIFIC"

STEEL HEATING BOILERS
AND
CIRCULATING TANKS

DEPARTMENT OF SALES:
322 MONADNOCK BUILDING, SAN FRANCISCO. Telephone Sutter 4665

CHICAGO

Condensation Pumps
Sewage Ejectors
Bilge Pumps

PUMP COMPANY

Garnett Young and Company

Pacific Coast Sales Engineers

612 Howard Street, San Francisco

SEATTLE

LOS ANGELES

PORTLAND

THE TORMEY CO.

General
Painters

Phone Franklin
5-5-9-8

1042 Larkin St., San Francisco, Cal.

Alvaline, Cementoline
and other
Jones-Duncan Products

MAGNER BROTHERS
PAINT MAKERS

Telephone: Market 113
414-424 Ninth St. San Francisco

HEATING-PLUMBING

COMPLETE PLUMBING AND
HEATING SYSTEMS INSTALLED
IN ALL CLASSES OF BUILDINGS
ALSO POWER PLANTS

GILLEY-SCHMID CO., Inc.

198 OTIS STREET, SAN FRANCISCO.
Tel. MARKET 965

“BLAZING” THE TRAIL
We've been doing it for many years—giving the Sportsman Better Value for Quality than he ever before received. *“Value at a Fair Price”* in everything for the Sportsman.

The
Elery Arms
Company

583-85 MARKET ST
SAN FRANCISCO, CAL.

SEND FOR CATALOG *The Sign of Quality*

Phone Douglas 3224

Hunter & Hudson
ENGINEERS

Designers of Heating, Ventilating
and Wiring Systems. Mechanical
and Electrical Equipment of
Buildings.

703 Rialto Bldg., San Francisco, Cal.

**BEAVER BLACKBOARD
BEAVER GREENBOARD**

SCHOOL FURNITURE
AND SUPPLIES—
OFFICE, BANK AND
COURTHOUSE FURNITURE—
THEATRE AND
AUDITORIUM SEATING

Rucker-Fuller Desk Co.

677 Mission St., SAN FRANCISCO, CAL.
434 Higgins Bldg., LOS ANGELES, CAL.
432 - 14th Street - OAKLAND, CAL.

NATIONAL ROOFING COMPANY
J. F. ELLIS

PACIFIC ROOFING COMPANY
J. B. McKEON

C. G. WILLIAMS

A. K. GOODMANSON

Members of
Builders and Roofers Exchange
2140 San Pablo Avenue, OAKLAND
Lakeside 271

RUSSWIN
BUILDERS' HARDWARE

JOOST BROS., Inc.
SAN FRANCISCO AGENTS

We Carry Complete Stock:
Fishing Tackle—Guns—Mechanics' Tools—
Paints—Crocery and Glassware—Stoves—
Household Goods. Telephone Market 891.

NO BRANCH STORE
Mazda Lamps Electric Goods

Oakland 540

The Largest Exclusive Electrical House in the State

MOTORS

BOUGHT — SOLD
RENTED — REPAIRED

Lighting Fixtures

Manufactured

Construction

MAINTENANCE
SUPPLIES

Estimates and engineering data cheerfully furnished

SPOTT ELECTRICAL CO.

Yours for Service

16th & CLAY STREETS

OAKLAND, CALIFORNIA

Building Apartment Houses Again

The records show a noticeable increase in the number of apartment houses for which contracts have been let this past month.

There is a tremendous demand for buildings of this type, strengthened by a return to normal prices. ☞ Conserve space by specifying

Portal Wall Beds

MARSHALL & STEARNS CO.

WALL BEDS

Highest Award Always

1152 PHELAN BLDG., SAN FRANCISCO

1774 BROADWAY, OAKLAND

A. D. COLLMAN

P. F. SPEIDEL

COLLMAN AND SPEIDEL**GENERAL
CONTRACTING****CONSTRUCTION
ENGINEERS**

Telephone SUTTER 4858

MONADNOCK BUILDING, SAN FRANCISCO

Phone Franklin 548

I. R. KISSEL*Decorator, Painter and Paperhanger*

1747 SACRAMENTO ST., Bet. Polk St. and Van Ness Ave., SAN FRANCISCO

ROBERT TROST

PHONE MISSION 2209

General Building ContractorWe Specialize in High Grade Work and Employ Skilled
Labor in every Branch of the Building Industry.26th and Howard Streets
SAN FRANCISCO

P. A. Palmer

Peter Petersen

W. L. Kelly

PALMER & PETERSEN**Contracting Engineers**

782-796 Monadnock Building

SAN FRANCISCO, CAL.

S. RASORI, RES. 2042 TAYLOR ST.
PHONE FRANKLIN 6258J. DEL FAVERO, RES. 1839 MASON ST.
PHONE FRANKLIN 9524**DEL FAVERO & RASORI**
GENERAL CONTRACTORS

MEMBERS OF THE S. F. BUILDERS EXCHANGE AND THE BUILDING INDUSTRIES ASS'N

OFFICE:
110 JESSIE STREET

SAN FRANCISCO, CALIF.

MONSON BROS.**GENERAL CONTRACTORS**

Telephone Market 2693

1908 Bryant Street, San Francisco

UNIT CONSTRUCTION COMPANY

(INCORPORATED)

ENGINEERING AND CONSTRUCTION

Telephone Kearny 28

429-36 Phelan Building, SAN FRANCISCO

J. D. HANNAH**Contractor and Builder**OFFICE: 142 Sansome Street
San Francisco, Cal.Telephone Douglas 3895
BUILDERS EXCHANGE, 180 JESSIE STREET

**MOUNT DIABLO CEMENT
COWELL SANTA CRUZ LIME**
ALL KINDS OF
BUILDING MATERIALS

HENRY COWELL LIME AND CEMENT CO.

Phone Kearny 2095

No. 2 MARKET STREET, SAN FRANCISCO

Automatic Fire Sprinklers

Protect your building and business from destruction by fire and reduce your Insurance Rate.

Pacific Fire Extinguisher Co.

FIRE PROTECTION ENGINEERS

424-440 HOWARD STREET
SAN FRANCISCO

MANUFACTURING PLANT
272 STEUART STREET

ARCHITECTS - BUILDERS - CONTRACTORS

MODERN CONDITIONS practically DEMAND gas heating. Be fore-handed and include provision for the use of GAS HEATING APPLIANCES in your plans and construction program. If an estimate on a complete heating system will help, do not hesitate to call on us.

Pacific Gas and Electric Company

Kawneer

Factory
Berkeley, Calif.
Berkeley 8710

MANUFACTURING COMPANY
of California

San Francisco Office:
180 Jessie Street
Sutter 6700

Kawneer
Store-Fronts
All Metal Mouldings

Kawneer
Simplex Windows
Weightless & Reversible

I. M. SOMMER**CONTRACTOR & ENGINEER**

Phone Kearny 4582

401 BALBOA BLDG., SAN FRANCISCO

K. E. PARKER COMPANY, Inc.
GENERAL CONTRACTORS

Phone Sutter 5661

Room 515 Clunie Building, SAN FRANCISCO

R. W. LITTLEFIELD
BUILDING CONSTRUCTION

357 12th Street, Room 9, Oakland, Cal.

Phone Lakeside 6750

H. H. HILP, Jr.

J. FRANK BARRETT

BARRETT & HILP**CONCRETE CONSTRUCTION BUILDERS GENERAL CONTRACTORS**

SHARON BUILDING, SAN FRANCISCO

TELEPHONE SUTTER 1168 or 1169

Res. Phone Mission 5049

JAMES F. SMITH — Plasterer

273 Minna Street, San Francisco

Phone KEARNY 740

Member Builders Exchange

STEELFORMS Signify ECONOMY, RAPIDITY, and EFFICIENCY

STEELFORM CONTRACTING COMPANYSTEELFORMS FOR
CONCRETE
BUILDINGSC. B. Hopkins, C. E., Manager
681 Market Street, San FranciscoCONCRETE JOIST
FLOOR
CONSTRUCTION**W. C. DUNCAN & CO.**

205 Sharon Bldg.

General Contractors

San Francisco

Telephone Kearny 772

M. E. VUKICEVICH

SPENCER B. BAGGE

VUKICEVICH & BAGGE
GENERAL CONTRACTORS

Phone Sutter 6700

Office, Builders Exchange, 180 Jessie St., San Francisco

245 Market St. **Standard Fence Co.** 310 Twelfth St.
 S. F. Kearny 2028 **WIRE AND IRON WORKS** Oakland 475

DESIGNERS - BUILDERS WIRE GRILL WORK—WIRE SCREEN
 FACTORY PROTECTION FENCE FLEXIBLE WIRE CONVEYOR BELT
 AVIARY AND TENNIS COURT FENCE WIRE SPECIALTIES

320 North Los Angeles Street, Los Angeles, Cal. Phone 67188

Steel Bars FOR CONCRETE REINFORCEMENT
 Cut to Length, Fabricated, Installed

BADT-FALK & CO.

Tel. Douglas 3466 346 Call-Post Bldg., 74 New Montgomery St., San Francisco

'WORK THAT SATISFIES''

ATHERLEY BROS.

PAINTING AND DECORATING 2032 Polk Street, San Francisco
 WINDOW SHADES MADE TO ORDER Phone Prospect 83

Phone FRANKLIN 689

MARTEN & FREDERICK
 UNITED WORK SHOPS

Designers, Makers and Contractors of Fine Furniture, Draperies and Complete Interiors.
 1374 SUTTER ST., SAN FRANCISCO

Phone Merritt 668

H. N. McNAB

Hardwood Floors  Floor Sanding

2307 - 17th Ave. Oakland, Cal

Res. Tel. Merritt 3600

HERBERT BECKWITH
Building Construction

Formerly with ARTHUR ARLETT 323 Newton Ave. Oakland

D. ZELINSKY & SONS
 PAINTERS AND DECORATORS

420 TURK STREET, SAN FRANCISCO

CHARLES T. PHILLIPS
 CONSULTING ENGINEER

PACIFIC BUILDING SAN FRANCISCO
 HEATING VENTILATION WIRING ILLUMINATION

Ideal Air-Washers. Ideal Fruit-Dryers. Fan Systems for Heating, Cooling and Drying.

Ideal Heating and Engineering Co.

Air-Conditioning, Heating, Cooling and Drying

192 ERIE STREET

Phone Market 3708

SAN FRANCISCO

Atlas Heating and Ventilating Co., Inc.

ENGINEERS and CONTRACTORS

STEAM AND HOT WATER HEATING, FANS, BLOWERS,
FURNACES, POWER PLANTS--SHEET METAL WORK

Phone Douglas 378

Fourth and Freelon Sts., Bet. Bryant & Brannan, SAN FRANCISCO

Illinois Automatic Vacuum and Vapor Systems of Heating

"TWENTY-FIVE YEARS OF QUALITY"

ILLINOIS ENGINEERING COMPANY

JAS. I. KRUEGER, *Representative*

Pacific Building, San Francisco

Telephone: Sutter 7057

HEATING
VENTILATION

FLOOR AND WALL TILING

PLUMBING
SHEET METAL WORK

SCOTT CO., Inc.

SUCCESSOR TO JOHN G. SUTTON CO.

243 MINNA STREET

SAN FRANCISCO

ALEX COLEMAN

CONTRACTING PLUMBER

706 ELLIS ST., SAN FRANCISCO

Phone FRANKLIN 1006

WM. F. WILSON COMPANY

MODERN SANITARY APPLIANCES

Special Systems of Plumbing for Residences, Hotels, Schools, Colleges, Office Buildings, Etc.

Phone Sutter 357

328-330 Mason Street, San Francisco.

C. DRUCKER

J. C. JAMES

JAMES & DRUCKER

Plumbing—Heating Contractors

Phone Market 275

450 Hayes Street, San Francisco, Cal.

UNITED BLOWER CO., Inc.

HEATING AND VENTILATING

Induced and Force Draft Apparatus, Dry Kilns, Etc.

1267 Folsom Street

SAN FRANCISCO

United
Multivane Fan
Wheel

Bath Room Fixtures

A BATH ROOM should be just as true an expression of the owner's taste and individuality as any other room of the house.

No more is it considered a luxury, but an absolute necessity to your health and comfort.

Our fixtures reflect the finest ideas in design and construction as related to sanitation, utility and service.

To give this subject the attention it demands, you should visit our display rooms at 64 Sutter Street, San Francisco.

Holbrook, Merrill & Stetson

DEALERS IN

Plumbers' Supplies, Iron Pipe and Fittings, Metals, Steam, Water and Hot Air Heating Apparatus, Stoves, Ranges, Kitchen Utensils.

Show Room, 64 SUTTER STREET

Main Office and Warehouse,

Sixth, Townsend and Bluxome Streets, San Francisco



Designers - Fabricators - Erectors

General Plate Work



Hydro - Pneumatic Pressure Tanks —
Hemispherical Bottom Tanks and Towers
— Oil and Water Tanks — Oil Stills —
Pipe Lines—Smoke Stacks—Well Casing
— Rock Screens — "Western" Corrugated Culvert Pipe.

Western Pipe and Steel Company OF CALIFORNIA

444 MARKET STREET
SAN FRANCISCO

1758 NORTH BROADWAY
LOS ANGELES



CEMENT GUN

Will Make Your
Concrete Waterproof

**Cement Gun Con-
struction Company**
of California

701 Balboa Building,
San Francisco

For
DAMS
RESERVOIRS
TUNNELS
BULKHEADS
CANAL
LININGS
CEMENT
FLUMES
use the
Cement Gun
—
SPEED
ECONOMY
PERMANENCE



LIGHT WEIGHT
FIREPROOF
EVERLASTING

STONE SHINGLES

VARIETY
and
DURABILITY
of COLORS

McCLENAHAN
PRODUCTS
COMPANY

670 Howard St.

INC.

San Francisco

QUEBRACHO!

One coat Argentine Quebracho paint on steel will out-wear three of red lead and graphite at fraction of cost. Contains South American gum that gives great tenacity. Ask about records on steel; also for damp-proofing concrete and for protecting piling from teredoes.

IMP MANUFACTURING CO.

732 Second St., Oakland Phone Lakeside 478

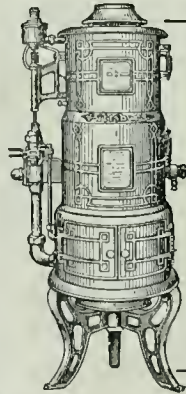

Pittsburg

It Insures
Instant
Hot Water
Service

**PITTSBURG WATER
HEATER COMPANY**

478 Sutter St., San Francisco
Phone Sutter 5025

**BUSINESS • SYSTEMS
OFFICE • FURNITURE**



F. W. Wentworth & Co.

539 MARKET ST., SAN FRANCISCO
DISTRIBUTORS FOR SALES ROOMS IN OAKLAND
LIBRARY BUREAU LOS ANGELES SEATTLE

WIRING



185 Stevenson Street, San Francisco
Phone Douglas 1832

NATIONAL WINDOW SHADE COMPANY, Inc.



Agents for
BRENLIN
The Long Wearing
Window Shade
Material

National Shades wear
twice as long as the
ordinary kind

Phone Franklin 552

244 EDDY STREET, SAN FRANCISCO, CAL.

Reconstructing Post-Intelligencer Building

The Post-Intelligencer building, Seattle, will be cut back to the present property line on Fourth avenue in the course of the remodeling program laid out by the Metropolitan Building Co. This necessitates the removal of nine feet from the Fourth avenue side of the building. The stores on Fourth avenue will be cut through to the Federal court on the west side of the building. The entrance of the building will be changed from Union street to Fourth avenue. The business office of the Post-Intelligencer Co. will be lowered to the street level and a mezzanine floor will be built over a portion of this space. The Post-Intelligencer Co. will take the entire third and fourth floors.

Class A Building

Messrs. Morgan, Walls & Morgan, 1124 Van Nuys building, Los Angeles, have taken bids for the erection of a six-story and basement Class A reinforced concrete store and loft building on the west side of Spring street, between Seventh and Eighth streets, Los Angeles, for the Cutts estate.

Hollow Tile Residence

Mr. A. C. Martin, 430 Higgins building, Los Angeles, is preparing plans for a two-story, 12-room hollow tile residence to be built on Ninth street, near Green, Los Angeles, for the Roman Catholic Bishop of Monterey and Los Angeles.

Homestead Blow-off Valves

are approved by the State Industrial Accident Commission and Insurance Companies. They are the cheapest and best Blow-off on the market today.

Satisfaction guaranteed or money refunded. Large stock carried in our San Francisco Store.

Catalog on request.



"Hovalco" Combination



Figure 22

W. E. MUSHET CO

FIRE BRICK
FIRE CLAY
BOILER BAFFLE TILE



502 MISSION STREET
San Francisco, Cal.
Telephone Sutter 4797



POSITIVE ELECTRIC INTERLOCK

(BAR LOCK TYPE)

Prevents Elevator Accidents Occurring at the Entrance Door

Approved by National Underwriters Laboratories—Meets requirements of Elevator Safety Orders of Industrial Accident Commission, State of California

ELEVATOR SUPPLIES COMPANY, Inc. 186 FIFTH STREET,
SAN FRANCISCO

Capital \$1,000,000

CALIFORNIA DEPARTMENT

Surplus \$1,122,000

THE FIDELITY AND CASUALTY COMPANY OF NEW YORK

Prompt Service for

BONDS AND CASUALTY INSURANCE

203-206 Merchants Exchange Building

SAN FRANCISCO, CAL.

ANY PLACE ANY TIME PROMPTLY "We Serve You"
JOHN H. ROBERTSON

Successor to Robertson & Hall

GENERAL INSURANCE

Phone Sutter 2750

621 First National Bank Building, San Francisco

PACIFIC DEPARTMENT

Globe Indemnity Company

BONDS and CASUALTY INSURANCE for CONTRACTORS

FRANK M. HALL, formerly Robertson & Hall, Mgr.

120 Leidesdorff Street Phone Sutter 2280 SAN FRANCISCO

National Surety Company of New York

The World's Largest Surety Company

Assets over \$20,000,000

Pacific Coast Department: 105 MONTGOMERY ST., SAN FRANCISCO, CAL.

Frank L. Gilbert, Vice-President

Phone, Sutter 2636

School and Theatre

STAGES AND EQUIPMENT

EDWIN H. FLAGG

SCENIC COMPANY, Inc.
400 Pantages Bldg., San Francisco, Cal.
1638 Long Beach Ave., Los Angeles, Cal.

PHONE DOUGLAS 2370

McLERAN & PETERSON

GENERAL CONTRACTORS

HEARST BUILDING

SAN FRANCISCO, CAL.

L. J. RUEGG

J. B. RUEGG

RUEGG BROS.

CONTRACTORS AND BUILDERS

Phone Douglas 1599

719 Pacific Building, SAN FRANCISCO

OPEN HEARTH

Reinforcing Steel Bars

Square Deformed — Immediate Shipment — Cut to required lengths

PACIFIC COAST STEEL COMPANY

Sales Office, Rialto Building. SAN FRANCISCO. Phone Sutter 1564

Architects and Building Contractors!

The HICKS-JUDD COMPANY, Inc., and SUNSET PUBLISHING HOUSE
have consolidated under the name of
ABBOTT-BRADY PRINTING CORPORATION
460 Fourth Street, San Francisco, Calif.

THE Binding of Magazines and Periodicals
will continue as one of Our Specialties;
also Expert Plate and Map Mounting.

 Reprinting of The Architect and Engineer Advertisements for Circular or File Use

George S. MacGruer }
Robert M. Simpson } Members of Builders Exchange

MacGruer & Simpson

CONTRACTING PLASTERERS

PLAIN AND ORNAMENTAL

Cement, Stucco and Artificial Stone

Phone Sutter 5688

540 Call-Post Building, San Francisco

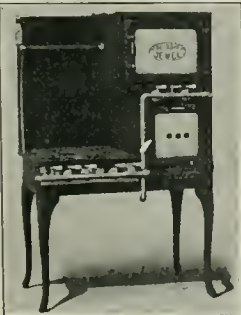
**Detroit Jewel Gas Ranges**

FOR HOME, RESTAURANT, HOTEL AND CLUB

We carry a Full Line of Stock Sizes

SELLING AGENTS

NATHAN DOHRMANN CO.

Geary and Stockton Streets, San Francisco

PARMELEE-DOHRMANN CO.

436-444 S. BROADWAY, LOS ANGELES

CALIFORNIA ARTISTIC METAL & WIRE CO.
 J. T. McCORMICK, PRESIDENT
 ORNAMENTAL IRON AND BRONZE
 349-365 SEVENTH ST. SAN FRANCISCO

MORTENSON CONSTRUCTION CO.
 CONTRACTORS FOR STRUCTURAL STEEL AND IRON
 H. MORTENSON, PRES. CHAS. G. MORTENSON, VICE-PRES. AND MGR.
 OFFICE AND SHOPS: CORNER 19TH AND INDIANA STREETS
 PHONE: MISSION 5033 SAN FRANCISCO, CAL.

RAYMOND GRANITE COMPANY, Inc.
 Owning and operating at Knowles, Madera County, the largest Quarry in the world
 CONTRACTORS FOR STONE WORK
 Designers and Manufacturers of Exclusive Monuments and Mausoleums
 Main Office and Yard: No. 1 and 3 Potrero Avenue, San Francisco, California
 Also at 1350-Palmetto Street, Los Angeles

CAEN STONE  **A. KNOWLES**
 A refined, elegant, interior finish. CONTRACTOR and PLASTERER
 442 Call-Post Building San Francisco

ZOURI SAFETY SASH BARS
 Accepted by the Insurance Underwriters for Safety Setting of Plate Glass used in Store Front Construction.
 **COBBLEDICK-KIBBE GLASS CO.**
 175 JESSIE ST. WASHINGTON AT THIRD ST.
 SAN FRANCISCO, CAL. OAKLAND, CAL.

Telephone Mission 58 A. A. Devoto, President
CENTRAL IRON WORKS, Inc.
 STRUCTURAL STEEL
 Office 2050 BRYANT STREET SAN FRANCISCO, CAL.

JOHNS-MANVILLE
 SERVES IN CONSERVATION
 Through
ASBESTOS and its ALLIED PRODUCTS

 **SCHRADER IRON WORKS, Inc.**
 STRUCTURAL STEEL CONTRACTORS
 Fire Escapes, Waterproof Trap Doors, Ornamental Iron Work
 1247-1249 HARRISON STREET SAN FRANCISCO, CAL.
 Bet. 8th and 9th Telephone Market 337

THE HYLOPLATE BLACKBOARD

SCHOOL FURNITURE
AUDITORIUM SEATING

MAPS
GLOBES
ATLASES

C. F. WEBER & CO.

985 Market Street
SAN FRANCISCO

222-224

S. Los Angeles St.
LOS ANGELES

100 W. Commercial
Row, RENO, NEV.

524 W. Washington
Street, PHOENIX, ARIZ.



A PROPRIETOR BOUND HIMSELF

to maintain fire insurance for the amount paid by him to the contractor as the construction of the building progressed. The building was burned while in course of construction and the company denied liability on the ground that the proprietor had no insurable interest. The court held that the proprietor had an insurable interest in the building equal to the amount paid to the contractor.

DIXWELL DAVENPORT
Manager Pacific Coast Department

BANKERS & SHIPPERS INSURANCE COMPANY

INSURANCE EXCHANGE BLDG.

SAN FRANCISCO

Telephone Kearny 3561



**BEAUTIFUL GARDEN
EFFECTS** for the City
and Suburban Home

MacRORIE-McLAREN CO.

Landscape Engineers
and General Nurserymen



Office
141 Powell Street
San Francisco

Nurseries at
Beresford,
San Mateo County

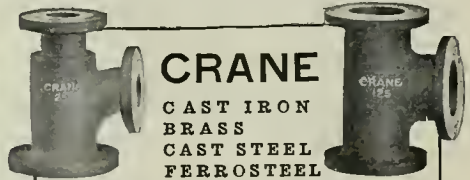

CRANE

CAST IRON
BRASS
CAST STEEL
FERROSTEEL

FLANGED FITTINGS

We have the largest line of patterns for flanged fittings for low pressure, standard, extra heavy, hydraulic, superheated and extreme hydraulic pressures, ranging in size from one-inch to sixty-inch, and for working pressures from fifty pounds to three thousand pounds.

The dimensions of the low pressure, standard and extra heavy fittings are in accordance with the 1915 *American Standard*.

Castings for special fittings also may be made at a minimum expense owing to our large equipment of special patterns which may be altered at very low cost.

CRANE CO.

PLUMBING SUPPLIES

2nd and Bran-
nan Sts., SAN
FRANCISCO.

348 9th Street
OAKLAND

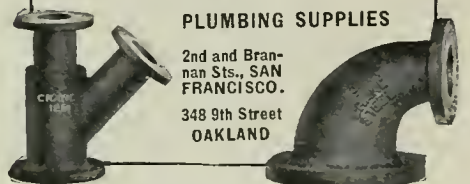



Western Safety Man'fg. Co. Inc.
Formerly
MEYERS ELECTRIC SAFETY SWITCH CO., Inc.
Manufacturers of
**Enclosed Externally Operated Safety
Switches, Knife Switches, Metal Switch
and Cut Out Boxes, Safety Switch Boards**
Office, 247 Minna Street SAN FRANCISCO
Telephone, Sutter 3008

****TYPE C****

Telephone
DOUGLAS
2046

Butte Electrical Equipment Company

BEECO

TRADE MARK - REG.

530
FOLSOM
STREET

**CONTRACTORS FOR POWER LIGHTING
AND INDUSTRIAL INSTALLATIONS**

For the convenience and guidance of our customers,
we have adopted **BEECO** as our trade name.

SAFETY ELECTRIC COMPANY

MANUFACTURERS OF

SWITCHBOARDS		PANEL BOARDS
SAFETY SWITCHES		SAFETY PANELS
SAFETY CONTROLS		KNIFE SWITCHES

59-65 Columbia Square San Francisco, Calif.
Telephone Market 2949

L. SIEBERT J. GENSLER

Drendell Electrical & Mfg. Co.
Incorporated

SWITCHBOARDS, PANEL BOARDS, KNIFE SWITCHES,
CABINETS, THEATRE INSTALLATIONS,
PROTECTIVE POWER PANELS

1345-1353 Howard St., San Francisco Telephone Market 1753

BUTTE ELECTRIC & MFG. CO. DOUGLAS 145
 (Paul C. Butte) at it since 1904
WIRING FOR BUILDINGS
 534 Folsom Street SAN FRANCISCO

H. S. TITTLE
 CONTRACTING ELECTRICAL ENGINEER
 766 FOLSOM ST., SAN FRANCISCO Phone SUTTER 4278



To Be "Low Bidder" Not Always Our Aim.
 Our most particular attention is given to prompt and skillful handling of all electrical work of any nature with "QUALITY AND SERVICE GUARANTEED."
 Our nation-wide organization and large experience in this field assures you always of fair estimates and absolute satisfaction.

F. E. NEWBERY ELECTRIC CO.
 163 Sutter St. (413 Lick Bldg.) San Francisco, Phone Sutter 521

San Francisco, Cal. Oakland, Cal. Los Angeles, Cal.

NEPAGE, McKENNY CO.
Electrical Engineers and Contractors
 Phone Sutter 2369 589 Howard St., San Francisco, Cal.

Phone Market 2541 M. FLATLAND

GLOBE ELECTRIC WORKS
 Estimates Furnished on Everything Electrical
ELECTRIC SUPPLIES
 1959 Mission Street, bet. 15th and 16th SAN FRANCISCO



Browne-Langlais Electrical Construction Co.
 Agents for
ROBBINS and MYERS MOTORS PACKARD MAZDA LAMPS
 213 MINNA STREET, SAN FRANCISCO Telephone Douglas 976

G. WALTER SPENCER, Manager Phone Lakeside 6750

SPENCER ELECTRIC CO.
 CONTRACTING AND ENGINEERING
 355 TWELFTH STREET OAKLAND, CALIF.

CHAS. G. FRIES. TELEPHONE SUTTER 5706 VICTOR A. KUEHN

LIBERTY ELECTRIC COMPANY
 479 Sutter St. **Electrical Contractors** San Francisco, Cal.



INSURANCE DID NOT SAVE THIS HOME

THE architect and builder are better able to prevent disaster by fire than any insurance agent. The architect builds fire insurance into the house; the agent merely writes it on paper.

FIRE CLAY FLUE LINING

specified by leading architects, used by reputable builders and required by ordinance of National Board of Fire Underwriters prevents 30% of residence fires by making it impossible for flames to reach woodwork through defective flues, and by preventing burning soot and sparks on the roof. For a very few dollars it *really* insures the results of your labor and the homes of your clients.

*Copy of the 1920 Chimney Ordinance
proposed by the National Board of
Fire Underwriters free on request.*

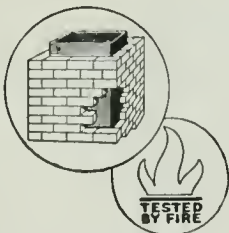

CLAY PRODUCTS ASSOCIATION
PITTSBURGH CHICAGO

(Los Angeles Pressed Brick Co., Los Angeles, Member)

A. H. Bergstrom
Eric Lange

S. F. Phone Kearny 3526

LANGE & BERGSTROM

Building Contractors

(Established 1900)

207-210 SHARON BLDG.
San Francisco

WASHINGTON BLDG.
Los Angeles

TIMKEN BLDG.
San Diego

CONTRACTOR'S MACHINERY

RANSOME MIXERS

OSHKOSH MIXERS

INSLEY SPOUTING PLANTS

OSHKOSH EVEREADY SAW RIGS INSLEY STEEL CARS and TRACKS
HOISTING BUCKETS, HOPPERS, GATES, ETC.

STEAM AND ELECTRIC HOISTS

EVERYTHING USED BY CONTRACTORS

CARRIED IN STOCK BY

GARFIELD & CO.

Hearst Building, San Francisco

Phone Sutter 1036

Lakewood Building Mixers

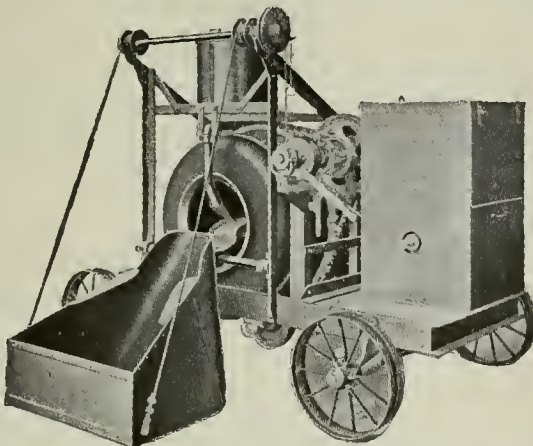

are in a class by themselves, as evidenced by repeated demands for these machines from large corporations and our most successful contractors. All merchantable sizes in stock—a complete line of equipment—steam, gasoline or electric power.

SMITH-BOOTH-USHER CO.

MACHINERY, SUPPLIES, PIPE AND FITTINGS

Factory Distributors

SAN FRANCISCO
50 - 60 Fremont Street

LOS ANGELES
228-238 Central Avenue

MILLER FOLDING IRONING BOARD

ELIMINATES WALL CABINET—IS INSTALLED IN KITCHEN CUPBOARD

NO { PLASTER GROUNDS
CASING OR PAINTING

SAVES { WALL SPACE AND LABOR
TIME AND MATERIAL

Exhibited and sold by { BUILDING MATERIAL EXHIBIT
77 O'Farrell Street, S. F., Tel. Sutter 5333

or LANNOM BROS. MFG. CO.
362 Magnolia St., Oakland.

MILLWORK Manufactured and Delivered Anywhere

Plans or Lists sent us for Estimates will have Careful and Immediate Attention.

Jno. Dudfield, Pres.
and Manager

DUDFIELD LUMBER CO. Joseph A. Jury,
Sec'y & Mill Supt.

MAIN OFFICE, YARD AND PLANING MILL — PALO ALTO, CALIFORNIA

FRANK PORTMAN MILL AND CABINET WORK

Window Frames and Inside Finish A Specialty
Band Sawing, Sticking and Sand Papering

1618-20 MISSION STREET

SAN FRANCISCO

ALL KINDS OF
MOULDINGS
IN STOCK

Phone Park 6204

A. C. SCHINDLER, President.

CHAS. F. STAUFFACHER, Secretary

THE FINK & SCHINDLER CO.

Manufacturers of INTERIOR WOODWORK AND FIXTURES
BANK, OFFICE AND STORE FITTINGS
SPECIAL FURNITURE

218-228 THIRTEENTH ST.
Bet. Mission and Howard Sts.

SAN FRANCISCO, CAL.
Telephone: Market 474

O. BAMANN, President

ERNEST HELD, Vice-President

HOME MANUFACTURING CO.

BANK, STORE AND OFFICE FITTINGS
FURNITURE AND HARDWOOD INTERIORS
CABINET WORK OF EVERY DESCRIPTION

543 and 545 BRANNAN ST.

Phone Kearny 1514

San Francisco, Cal.

MULLEN MANUFACTURING CO.

BANK, STORE AND OFFICE FIXTURES—CABINET WORK OF
GUARANTEED QUALITY—CHURCH SEATING

Telephone Market 8092

Office and Factory:
64 Rausch St., Bet. 7th and 8th Sts., San Francisco

JAMES L. McLAUGHLIN

GENERAL CONTRACTOR

Phones Douglas 6645 - 6646

251 KEARNY STREET, SAN FRANCISCO

Dolan Wrecking & Construction Co.

(D. J. DOLAN)

Lumber, Lath, Nails, Shingles, Doors, Windows
and Plumbing Supplies, New and Second Hand

Phone Market 4264

Office and Yard, 1607-1639 MARKET ST., SAN FRANCISCO

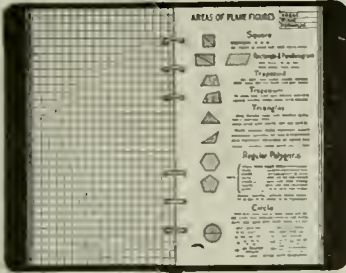

LEFAX

LEAF + FACTS

Pocket Cyclopedias

The facts that you want *instantly available* are not the same ones that some one else in your profession might desire. That's why LEFAX is made Loose Leaf. You file, in whatever order you wish, those sheets of facts that you want to have constantly at hand. If you wish, you may also file, in the same book, sheets for keeping data, for figuring, etc.

LEFAX sets cost but 50c. and \$1.00. You cannot fully appreciate their handiness—their value—until you use them. Ask us about them.

SCHWABACHER-FREY STATIONERY CO.
 PRINTERS LITHOGRAPHERS STATIONERS
 611 Market Street San Francisco

Steam Heating and Ventilating



For Commercial and Public Buildings

Furnace Heating
 For the Home

Mangrum & Otter, Inc.

827-831 Mission Street

Phone Kearny 3155 SAN FRANCISCO

Pacific Coast Office Building Vacancies

The Office Building Bulletins of the several Pacific Coast cities show the following facts concerning vacancies in this section of the country:

Offices Vacancies Rented		
Portland	7,088	121 98.3%
Seattle	5,072	84 98.3%
San Francisco.	16,361	369 97.8%

The Bulletin of the Portland Association of Building Owners and Managers advises readers to keep these figures in mind when they hear gossip to the effect that vacancies in office buildings are increasing rapidly.

Local Materials Favored

Mr. Charles H. Alden, president of Washington State Chapter, American Institute of Architects, in discussing the subject of upbuilding Northwest industry before the Pacific Northwest Products Committee of the Seattle Chamber of Commerce at a recent weekly meeting, stated that members of the profession in Seattle can be relied upon to aid in the upbuilding of the industry by specifying Pacific Northwest building materials, when they correspond in price and quality with those produced elsewhere.

ROBERTS MFG. CO.

Lighting Fixtures
 Electric Appliances
 Incandescent Lamps

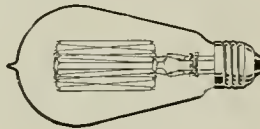

WILLYS FARM LIGHTING
 AND POWER PLANTS

663 Mission St., San Francisco

Washed Gravel and Sand

Quality For Concrete Construction *Service*

Thoroughly Washed and Accurately Graded—An Ideal Concrete Aggregate



View of Plant at Niles

California Building Material Co.

Plants at Eliot and Niles, Cal.

500 Call Building, San Francisco

Otis Elevators

THE Architect or Engineer can specify "Otis Elevators" assured that the responsibility of the Otis Elevator Company extends beyond satisfactory installation. Buildings equipped with Otis Elevators enjoy the advantage of the prompt service and careful inspection rendered by any of our hundred offices. Such service means your clients' gratitude.

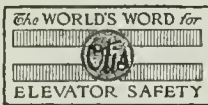

Otis Elevator Company

Offices in All Principal Cities of the World
2300 Stockton Street, San Francisco, Calif.

THE ARCHITECT & ENGINEER



JUNE 1921

Published in San Francisco

This Issue Special Spokane Number
\$1.00

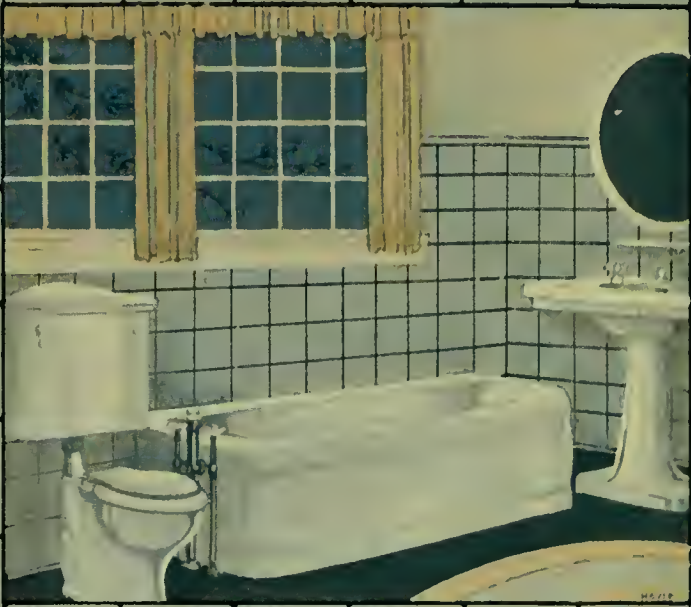

Beautiful simplicity
characterizes ~
PACIFIC
PLUMBING FIXTURES

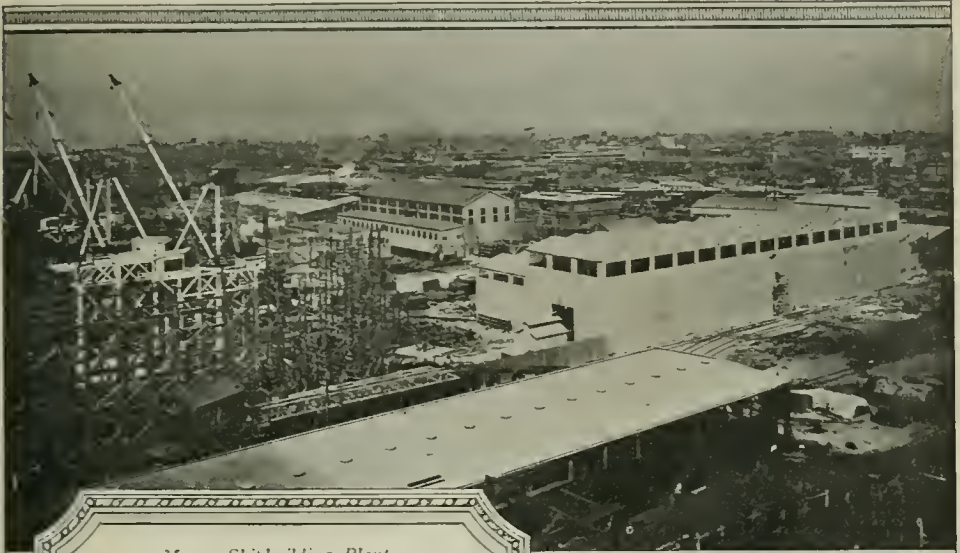

*Moore Shipbuilding Plant,
Oakland, Calif.
Buildings covered with
P.A.B.C.O. 10 YEAR ROOFS.*

PABCO ROOFS on Industrial Plants

The great Moore Shipbuilding Yard at Oakland, Cal., is an outstanding example of a modern and complete industrial plant. In keeping with the policy of using only the best of equipment and materials, PABCO ROOFS, of course, were specified for the buildings.

PABCO 10 and 20-Year Roofs

appeal to Architects, Engineers and owners because of the high quality of materials, the proved method of construction, and particularly because they are least expensive in the long run, due to the low cost per year of service.

Write for Specifications and
Complete Details

THE PARAFFINE COMPANIES, INC.
San Francisco, California

Leland Rosener,
Engineer



Roofings — Felts
Roof Coatings
Building Papers
Floor Covering
Wall-Boards
Waterproofing
Materials
Paints
Box-Board
Paper Boxes
Fibre Containers

"Each the standard
of its kind"



New Home
BANK OF ITALY
 San Francisco, Calif.
 BLISS & FAVILLE,
 Architects

We will install in the Bank of Italy the most complete and best Electric Clock System west of Chicago.

**Self-winding Master Clock,
 Marble Dial Secondary
 Clocks,
 Electric Time Recorders,
 Electric Time Stamps.**

Plans, specifications and any engineering information, estimates, etc., cheerfully furnished to architects, engineers or any one interested in this special line of work.

PACIFIC ELECTRIC CLOCK CO.
 J. J. ESTABROOK
 516 Wells Fargo Building,
 San Francisco, Calif.
 Telephone Sutter 809

QUALITY HARDWARE



LOCKS AND BUILDERS'
 HARDWARE

PALACE HARDWARE CO.

"San Francisco's Leading Hardware Store"

581 MARKET STREET. SUTTER 6060

UNION CONSTRUCTION CO.

CONTRACTORS and ENGINEERS

Steel for all Types of Building Construction and Bridges

Tank and Pipe Work

604 Mission St., ↘ San Francisco
 Sutter 2790

Key Route Basin, ↘ Oakland
 Lakeside 6300

Compare These Lavatories



Old Style

All-in-One Lavatory

BOTH lavatories are of the same type, the popular priced lavatory so much in use in the average bathroom of today; both sell for the same price—but in all other respects they are entirely different.

The old style lavatory has exposed metal parts and pipes underneath—the All-in-One Lavatory has no exposed metal parts, the entire fixture being finished in white enamel. The old style lavatory has two outlets, one for hot water and one for cold—the All-in-One, only one outlet with a special mixing device that blends the hot and cold water, enabling one to wash in running water of the correct temperature. The old style lavatory has a plug and chain—the All-in-One, a patented waste plug with spring and cap.

The All-in-One Lavatory eliminates all of these exposed metal parts and connecting joints by casting the hot and cold water inlets, waste pipe, overflow integral, faucets and soap cup with the fixture itself. It can be installed much more quickly than the old style fixture as there is only one connection to be made. It is much more attractive and is far easier to keep clean—and it costs no more than the old style lavatory.

All-in-One Lavatories are made in all the different styles. All-in-One Bathtubs are designed on the same principle and are made in all sizes and styles. Let us send you Free illustrated catalog fully describing All-in-One Plumbing Fixtures.

All-in-One Company

504 Marsh-Strong Building, Los Angeles

Dept. A

WHEN CHOOSING ELECTRIC
TIME EQUIPMENT YOU CERTAINLY
WANT THE BEST

- 13 Schools in Oakland,
and Oakland City Hall.
- 5 Schools in Berkeley,
and University of California.
- 12 Schools in San Francisco,
and Ferry Building.
- 4 State Normal Schools,
and Agnew State Hospital.

All completely equipped with the
Standard Electric Time Company's
equipment.

You cannot afford to take chances.
Specify Standard. If in doubt refer
to any of the above.

STANDARD ELECTRIC TIME COMPANY

461 MARKET STREET

Phone Sutter 241 SAN FRANCISCO, CAL.

DEPENDABILITY

"Since 1858"

LINOLEUMS WINDOW SHADES

Carpets
Draperies
Rugs

Estimates Furnished

D. N. & E.

Walter & Co.

562-572 Mission Street
SAN FRANCISCO

Los Angeles Portland Seattle



PROMETHEUS

The Electric Food and Plate Warmer

Wherever meals are cooked and served, in
apartments, residences and institutions, Prom-
etheus is a highly valued asset. The wire-
less heating units placed independently of the
shelves keep food hot and tasty until ready to
serve and cannot injure the finest china.

Write for information and list of installations

The Prometheus Electric Co.

Manufacturers

511 West 42d Street, New York

Showroom, **M. E. HAMMOND**
Mezzanine Floor Pacific Bldg., San Francisco



IT'S not enough to say "Good For
All Time" unless there is something
back of it. ☐ There is in this case.
☐ Vermont Marble already has an un-
blemished record of over one hundred
and fifty years. ☐ We know what it will
do. It's not necessary to guess at it.
☐ And our quarries in Alaska and Texas
are also proving themselves. ☐ So please
don't think of "Good for All Time" as
merely a happy phrase.

IT'S THE MARK OF A SERVICE.
It means exactly what it says.

Vermont Marble Company
PROCTOR, VERMONT

San Francisco - Portland - Tacoma

STEEL BARS

FOR

CONCRETE REINFORCEMENT

CORRUGATED
TWISTED
SQUARES
OR
ROUNDS
CUT
TO
LENGTH



FABRICATED
AND
INSTALLED
—
LUMP SUM
BIDS
ON
WORK
COMPLETE

Office, 444 MARKET STREET
Warehouse, 10th and Bryant Streets
Phone: Sutter 2720

“HYDRATITE” FOR WATERPROOFING AND HARDENING CONCRETE “HORNSTONE”

How daylight helps workmen do more and better work

DAYLIGHT and fresh air are powerful aids to production. The stimulus of plenty of light and fresh air is reflected in greater volume and accuracy of output, with diminished wastage. Operatives enjoy better health, are freer from eye-strain, lose fewer days through sickness. Labor turnover is reduced—output is noticeably increased. All of this is accomplished with TRUSCON Daylight Sash.

Truscon Daylight Engineers at your Service

All sizes of Truscon Steel Sash carried in stock in San Francisco Warehouse.

Largest stock of fireproof material and reinforcing bars on the Pacific Coast.

TRUSCON STEEL COMPANY

CHAS. HOLLOWAY, JR., Branch Manager

527 Tenth Street, San Francisco



TRUSCON DAYLIGHT SASH

E. B. Noble, President
A. E. Wilkins, Vice-Pres.

Beam, Angle, Channels, and Universal Mill
Plates for immediate shipment from stock

Pacific Rolling Mill Co.

SUPPLIERS OF

FABRICATED STRUCTURAL STEEL, Forgings,
Bolts, Rivets, Frogs, Switches, Cast Iron Castings

General Office and Works
17th and MISSISSIPPI STS., SAN FRANCISCO
Telephone Market 215

Beams
Channels
Angles
Plates

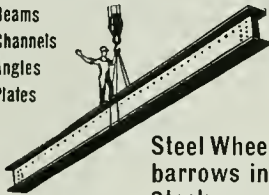

Steel Wheel-
barrows in
Stock

Western Iron Works

W. B. MORRIS, Pres. H. H. MORRIS, V.-P. L. J. GATES, Sec.

STRUCTURAL IRON AND
STEEL CONTRACTORS

141-147 Beale St. and 132-148 Main St. SAN FRANCISCO

Phones: GARFIELD 2575--2576

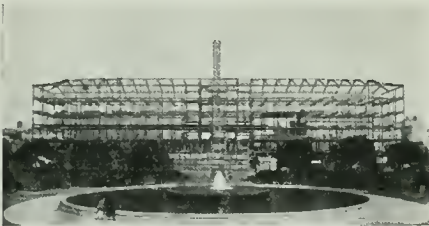

Bliss & Faville, Architects

Steel Frame, California
State Building, Civic Center,
San Francisco.

FABRICATED BY

THE PALM IRON AND
BRIDGE WORKS (Incorporated)

15th and R Streets, Sacramento

Cast Iron Stairs and Store Fronts

Bank and Office Railings, Elevator
Enclosures and Fire Escapes.

C. J. HILLARD CO., Inc.

Nineteenth and Minnesota Streets
Telephone Mission 1763

SAN FRANCISCO, CAL.

Architects' Specification Index

(For Index to Advertisements, see next page)

ART METAL

American Art Metal Works, 13 Grace street,
San Francisco.

ARCHITECTURAL TERRA COTTA

Gladding, McBean & Company, Crocker Bldg.,
San Francisco.

Tropico Potteries, Inc., Glendale, Cal.

ASBESTOS ROOFING, PACKING, ETC.

H. W. Johns-Manville Co., San Francisco, Los
Angeles and Portland, Ore.

AUTOMATIC SPRINKLERS

Grinnell Co. of the Pacific, 453 Mission St., San
Francisco.

Pacific Fire Extinguisher Co., 424 Howard St.,
San Francisco.

AUTOMOBILES

W. L. Hughson Co., Geary St., at Van Ness Ave.,
San Francisco.

AWNINGS, TENTS, ETC.

W. A. Plummer, Front, at Pine St., San Fran-
cisco.

BANKS

First National Bank, Post and Montgomery
streets, San Francisco.

BANK FIXTURES AND INTERIORS

Fink & Schindler, 218 13th St., San Francisco.

C. F. Weber & Co., 985 Market St., San Fran-
cisco.

Home Mfg. Co., 543 Brannan St., San Fran-
cisco.

Mullen Manufacturing Co., 64 Rausch St., San
Francisco.

Rucker-Fuller Desk Co., 677 Mission St., San
Francisco.

Pacific Manufacturing Company, San Francisco,
Los Angeles, Oakland and Santa Clara.

BELTING AND PACKING

New York Belting and Packing Company, 519
Mission St., San Francisco.

H. N. Cook Belting Co., 401 Howard St., San
Francisco.

Smith-Booth-Usher Co., San Francisco and Los
Angeles.

BLACKBOARDS

C. F. Weber & Co., 985 Market St., San Fran-
cisco, Los Angeles and Reno, Nevada.

Beaver Blackboards and Greenboards, Rucker-
Fuller Desk Company, Coast agents, 677 Mis-
sion St., San Francisco; also Oakland and
Los Angeles.

BLINDS—VENETIAN AND DIFFUSELITE

J. G. Wilson Corporation, Metropolitan Bldg.,
Los Angeles; Waterhouse-Wilcox, Underwood
Bldg., San Francisco.

Western Venetian Blind Co., Long Beach Ave.,
Los Angeles; C. F. Weber & Co., San Fran-
cisco.

BOILERS

California Hydraulic Engineering & Supply Co.,
70-72 Fremont St., San Francisco.

General Boilers Co., 322 Monadnock Bldg., San
Francisco.

Kewanee Water Supply System, Simonds Ma-
chinery Co., 117 New Montgomery St., San
Francisco.

BOOK BINDERS

Abbott-Brady Printing Corp'n, 460 Fourth St.,
San Francisco.

H. S. Crocker Co., 565 Market St., San Fran-
cisco.

BONDS FOR CONTRACTORS

American Mutual Liability Insurance Co., Balboa
Bldg., San Francisco.

Bonding Company of America, Kohl Bldg., San
Francisco.

Bankers & Shippers Insurance Co. of New York,
Insurance Exchange Bldg., San Francisco.

Globe Indemnity Co., 120 Leidesdorff St., San
Francisco.

Fidelity & Casualty Co. of New York, Mercantile
Exchange Bldg., San Francisco.

John H. Robertson, 621 First National Bank
Building, San Francisco.

National Surety Co. of New York, 105' Mont-
gomery St., San Francisco.

BRASS GOODS, CASTINGS, ETC.

H. Mueller Manufacturing Co., 635 Mission St.,
San Francisco.

BRICK, PRESSED, PAVING, ETC.

Los Angeles Pressed Brick Co., Frost Bldg., Los
Angeles.

United Materials Co., Crossley Bldg., San Fran-
cisco.

Cannon & Co., Sacramento; and 77 O'Farrell
street, San Francisco.

BRICK & CEMENT COATING

Armorite and Concreta, manufactured by W. P.
Fuller & Co., all principal Coast cities.

The Paraffine Companies, Inc., 34 First St., San
Francisco.

Lapidolith, L. Sonneborn Sons, Inc., San Fran-
cisco, Los Angeles, Portland and Seattle.

R. N. Nason & Co., 151 Potrero Ave., San
Francisco.

Wadsworth, Howland & Co., Inc., Boston, Mass.,
manufacturers of Bay State Brick & Cement
Coating. Hambley & Son, agents, San Fran-
cisco and Los Angeles.

BRICK STAINS

Samuel Cabot Mfg. Co., Boston, Mass., agencies
in San Francisco, Oakland, Los Angeles, Port-
land, Tacoma and Spokane.

Armorite and Concreta, manufactured by W. P.
Fuller & Co., all principal Coast cities.

BUILDERS' HARDWARE

Joost Bros., agents for Russell & Erwin Hard-
ware, 1053 Market St., San Francisco.

The Stanley Works, New Britain, Conn., repre-
sented in San Francisco and Los Angeles by
John Rountree & Co.

Palace Hardware Company, Agents Corbin goods,
581 Market St., San Francisco.

Richards-Wilcox Mfg. Co., Aurora; Ewing-Lewis
Co., 626 Underwood Bldg., San Francisco.

GRINNELL AUTOMATIC SPRINKLER GRINNELL COMPANY

OF THE PACIFIC

VALVES
PIPE and FITTINGS

ENGINEERS AND CONTRACTORS
453 Mission Street, San Francisco

CHEMICAL FIRE
EXTINGUISHERS
and FIRE ENGINES

When writing to Advertisers please mention this magazine.

An Index to the Advertisements

	Page		Page		Page
Abbott-Brady Printing Corp.	151	Grinnell Co.	7	Palace Hardware Co.	2
All-in-One	3	Gunn Carle Company	5	Palm Iron Works	6
American Art Metal Works	22	Haines, Jones & Cadbury	131	Palmer & Petersen	142
American Face Brick Ass'n.	129	Hamilton, John E.	132	Parafine Companies, Inc.	1
American Insulex Co.	38	Hannah, J. D.	142	Parker, K. E. Co., Inc.	144
American Mutual Liability Insurance Co.	10	Hauser Window Co.	36	Partman, Wm. B.	130
American Mail Chute	28	Haws Sanitary Drinking Faucet Co.	138	Petrium Sanitary Sink Co.	32
American Marble & Mosaic Co.	44	Hill, Hubbell Co.	124	Phillips, Chas. T.	145
American Rolling Mill Co.	133	Hillard, C. J., Co.	6	Pitcher Door Hanger	32
American Window Glass Co.	42	Hind, Rolph Co.	14	Pittsburg Water Heater Co.	148
Anderson, V. A.	17	Holbrook, Merrill & Stetson	147	Plummer, W. A.	138
Atherly Bros.	145	Home Mfg. Co.	158	Pope & Talbot	15
Atlas Heating & Ventilating Co.	146	Hughson, W. L. Co.	26	Portman, Frank	158
		Humphrey Radiantfire	25	Prometheus Electric Co.	4
		Hunt, Robt. W. & Co.	132		
		Hunter & Hudson	140	Quandt, A & Son	122
Bacon, Edward R., Co.	119	Ideal Heating & Engineering Co.	146		
Badt-Falk & Co.	145	Illinois Engineering Co.	146	Raymond Granite Co.	152
Baird-Bailhache Company	34	Imp Mfg. Co.	148	Reliance-Grant Elevator Equipment Co.	22
Barrett & Hilp	144	Imperial Waterproofing	28	Richard Wilcox	31
Bartlett, John M.	136	James & Drucker	146	Roberts Mfg. Co.	159
Bass-Hueter Co.	3rd Cover	Jarvis, T. P. Mfg. Co.	43	Robertson, John H.	150
Beach-Robinson Co.	27	Johns-Manville Co.	152	Ruegg Bros.	150
Beckwith, Herbert	145	Johnson, S. T.	43	Rucker-Fuller Desk Co.	140
Bowser & Co., S. F.	41	Johnson Service Co.	11	Ryan, M. E.	136
Brenner, John	136	Joost Brothers	140	Safety Electric Co.	154
Brimstool Co.	22	Kawneer Mfg. Co.	143	Samson Spot Cord	136
Browne-Langlais Company	155	Kerner Incinerator Co.	42	San Francisco Elevator Co.	11
Builders and Roofers Exchange	140	Kissel, I. R.	142	Santa Fe Lumber Co.	15
Bunting Iron Works	143	Knittle-Cashel Co., Inc.	13	Scott Co.	146
Butte Electrical Equipment Co.	154	Knowles, A. H.	152	Schrader Iron Works	152
Butte Electric & Mfg. Co.	155	Lannom Bros. Mfg. Co.	158	Schwabacher-Frey Co.	159
		Lange & Bergstrom	157	Simmons, O. M. Co.	12
Cabot, Samuel (Inc.)	41	Larson Sampson Co.	136	Simonds Machinery Co.	38
California Artistic Metal and Wire Co.	152	Liberty Electric Co.	155	Smith-Booth-Usher Co.	157
California Bldg. Material Co.	160	Littlefield, R. W.	144	Sommer, I. M.	144
California Brick Co.	33	Los Angeles Pressed Brick Co.	127	Sonneborn Sons, Inc.	125
California Granite Co.	136	MacGruer & Simpson	151	Sonnenschein Bros.	27
California Hydraulic Engineering and Supply Co.	10	MacRorie-McLaren Co.	153	Soulé, Edward L. Co.	132
California Steam and Plumbing Supply Co.	137	Magner Bros.	140	Spencer Electric Co.	155
Cannon & Co.	24	Mangrum & Otter	159	Spencer Elevator Co.	34
Cement Gun Construction Co.	148	Marshall & Stearns Co.	241	Spott Electrical Co.	141
Central Electric Co.	148	Marten & Fredericks	145	Standard Metal Mfrs.	153
Central Iron Works	152	McClenahan Products Co.	148	Standard Varnish Works	117
Cobbleck-Kibbe Glass Co.	152	McCray Refrigerator Co.	28	Standard Electric Time Co.	4
Coleman, Alex	146	McLaughlin, Jas. L.	158	Standard Fence Co.	145
Collman & Speidel	142	McLeran & Peterson	150	Stanley Works, The	115
Commercial Export and Import Co.	138	Meese & Gottfried	130	Stefform Contracting Co.	144
Cook Belting Co.	38	Moline Heat	16	St. Francis Hotel	123
Cowell Lime & Cement Co.	143	Montagne Range & Furnace Co.	18	Stockholm, Chas. & Son	136
Crane Co.	153	Monson Bros.	142	Strable Hardwood Co.	37
Crocker, H. S. Co.	135	Mortenson Construction Co.	152	Sunset Lumber Company	15
		Mott Co. of Calif.	18	Tay Company, George H.	26
Davis, R. J.	9	Mueller Mfg. Co.	18	Taylor Galleries	27
Del Favero and Razoni	142	Mullen Mfg. Co.	158	Tittle, H. S.	155
Del Monte Properties Co.	29	Musket Co., W. E.	149	Torney Co.	140
Detroit Steel Products Co.	44	Musto Sons Keenan Co.	13	Tropico Potteries, Inc.	24
Dolan Wrecking & Construction Co.	158	Myers & Schwartz	33	Trost, Robt.	142
Drendell Elec. & Mfg. Co.	154			Truscon Steel Co.	5
Dudfield Lumber Co.	158	Nason, R. N. & Co.	9	U-Turn-It Housekeeping System, Inc.	134
Duncan, W. C.	144	Nathan, Dohrmann Co.	151	Uhl Bros.	38
Dunham, C. A. Co.	122	National Mill & Lumber Co.	32	Union Construction Co.	2
		National Surety Co.	150	Unit Construction Co.	142
Electric Appliance Co.	126	National Terra Cotta Society	121	United Materials Co.	127
Electric Sales Service Co.	12	National Valve Co.	130	U. S. Metal Products Co.	36
Elevator Supplies Co.	150	National Window Shade Co.	149	U. S. Steel Products Co.	40
Ellery Arms Co.	140	Nelson, James A.	18	Vermont Marble Co.	4
		Ne Page, McKenny Co.	155	Victory Manufacturing Co.	20
Faber, Eberhard	21	Newbery Electric Co.	155	Vukicevich & Bagge	144
Fess System Co.	43	New York Belting and Packing Co.	137		
Fidelity & Casualty Co. of N.Y.	150	Norris Co., L. A.	28	Wadsworth, Howland & Co., Inc	119
Fink & Schindler Co., The	158	Oak Flooring Mfrs' Ass'n	19	Walter, D. N. & E. Co.	4
Fire Protection Products Co.	36	Ocean Shore Iron Works	138	Wayne Oil Tank & Pump Co.	29
First National Bank	120	Old Mission Portland Cement Co.	35	Wayne, J. F. Co.	149
Flagg, Edwin H., Scenic Co.	150	Otis Elevator Co.	160	Weber, C. F. & Co.	153
Freeman Art Shop	27	Pacific Coast Steel Company	151	Wentworth, F. W.	148
Fuller & Goepf	34	Pacific Electric Clock Co.	2	West Coast Porcelain Co.	Back Cover
Fuller, W. P. Co.	23	Pacific Fire Extinguisher Co.	143	Western Blind & Screen Co.	39
		Pacific Gas and Electric Co.	143	Western Safety Mfg. Co.	154
Garfield Company	157	Pacific Mfg. Co.	15	Western Iron Works	6
Garnett Young & Co.	31	Pacific Materials Co.	44	Western Pipe and Steel Co.	147
General Boilers Co.	139	Pacific Painting and Roofing Co.	136	White Bros.	114
General Gas Light Co.	25	Pacific Plumbing Fixtures, 2d Cover	136	Wilson, J. G., Corp.	116
Gilley-Schmid Co.	140	Pacific Porcelain Ware Co., 2d Cover	136	Wilson, W. F., Co.	146
Gladding, McBean & Co.	24	Pacific Rolling Mills	6	Witt, G. E. Co.	44
Glode Electric Works	155			Zelinsky D., & Sons	145
Globe Indemnity Co.	150				

Nason's Opaque Flat Finish

A Flat Washable Oil Paint, made in soft Kalsomine tints—a practical article for Walls, Ceilings, Etc. Agency for Tamm & Nolan Company's High Grade VARNISHES and FINISHES, made on the Pacific Coast to stand our climatic conditions.

R. N. NASON & CO. Paint Makers
151 Potrero Ave.—436 Market St., San Francisco--Portland-Seattle-Oregon

ARCHITECTS' SPECIFICATION INDEX—Continued

BUILDING MATERIALS, SUPPLIES, ETC.

Pacific Materials Co., Underwood Bldg., San Francisco.
Waterhouse-Wilcox Co., 523 Market St., San Francisco.
Johns-Manville Company, Post and Mason Sts., San Francisco.

CABINET MAKERS

Home Manufacturing Company, 543 Brannan St., San Francisco.
Fink & Schindler Co., 218 13th St., San Francisco.
Mullen Manufacturing Company, 64 Rausch St., San Francisco.
Lannom Bros. Mfg. Co., 5th and Magnolia sts., Oakland.
Pacific Mfg. Co., San Francisco, Los Angeles and Oakland.
Frank Portman, 1618 Mission St., San Francisco.

CARPETS

John Breuner Co., 281 Geary St., San Francisco.
D. N. & E. Walter, Mission near Second street, San Francisco.

CASEMENT WINDOW HARDWARE

Richards-Wilcox Mfg. Co., Aurora, Ill., and Underwood Bldg., San Francisco.

CEMENT

Atlas Portland Cement Co., all principal cities.
Mt. Diablo, sold by Henry Cowell Lime & Cement Co., 2 Market St., San Francisco.
Medusa White Portland Cement, manufactured by Sandusky Cement Co., represented in San Francisco by Pacific Building Materials Co., Underwood Bldg., San Francisco.
Old Mission Portland Cement Co., Mills Building, San Francisco.

CEMENT EXTERIOR WATERPROOF PAINT

Armorite, sold by W. P. Fuller & Co., all principal Coast cities.
Bay State Brick and Cement Coating, manufactured by Wadsworth, Howland Co., Boston, Mass. James Hambley & Son, Distributors, San Francisco and Los Angeles.
Hill, Hubbell & Company, No. 1 Drumm St., San Francisco.
Imperial Waterproofing, manufactured by Brooks & Doerr, Reed Baxter, agent, Merchants National Bank Bldg., San Francisco.
Cement coating, manufactured by L. Sonneborn Sons, Inc., San Francisco, Los Angeles, Portland and Seattle.
Medusa White Portland Cement, manufactured by Sandusky Cement Co., represented in San Francisco by Pacific Materials Co., 525 Market St., San Francisco.

CEMENT FLOOR COATING

Lapidolith, manufactured by L. Sonneborn Sons, Inc., San Francisco, Los Angeles, Portland and Seattle.

CEMENT GUN

Cement Gun Construction Company of California, 701 Balboa Bldg., San Francisco.

CEMENT TESTS—CHEMICAL ENGINEERS

Robert W. Hunt & Co., 251 Kearny St., San Francisco.

CLAY PRODUCTS

Cannon & Co., Sacramento, Cal.
Gladding, McBean & Co., Crocker Bldg., San Francisco.
Los Angeles Pressed Brick Co., Frost Bldg., Los Angeles.
Tropico Potteries, Inc., Glendale, Cal.
United Materials Co., Sharon Bldg., San Francisco.

CLOCKS—ELECTRIC TIME

Pacific Electric Clock Co., 516 Wells-Fargo Bldg., San Francisco.
Standard Electric Time Co., 461 Market St., San Francisco.

COLD STORAGE PLANTS

H. W. Johns-Manville Co., Post and Mason Sts., San Francisco.
T. P. Jarvis Crude Oil Burning Co., 275 Connecticut St., San Francisco.

CONCRETE CONSTRUCTION

Barrett & Hilt, Sharon Bldg., San Francisco.
Clinton Construction Co., 140 Townsend street, San Francisco.
K. E. Parker Co., Inc., Clunie Bldg., San Francisco.
Palmer & Petersen, Monadnock Bldg., San Francisco.

I. M. Sommer, 401 Balboa Bldg., San Francisco.
Steelform Contracting Company, 681 Market St., San Francisco.

CONCRETE HARDENER

Gunn, Carle & Co., Inc., 444 Market street, San Francisco.

CONCRETE MIXERS

Foote and Jaeger mixers sold by Edward R. Bacon Co., 51 Minna St., San Francisco, also Los Angeles.
Ransome mixers sold by the Garfield Co., Hearst Bldg., San Francisco.
Smith-Booth-Usher Co., San Francisco and Los Angeles.

CONCRETE REINFORCEMENT

Edw. L. Soule Co., Rialto bldg., San Francisco.
United States Steel Products Co., San Francisco, Los Angeles, Portland and Seattle.
Twisted Bars. Sold by Gunn, Carle & Co., Inc., 444 Market St., San Francisco.
Clinton Welded Wire Fabric, L. A. Norris Co., 140 Townsend St., San Francisco.
Pacific Coast Steel Company, Rialto Bldg., San Francisco.
Triangle Mesh Fabric. Sales agents, Pacific Materials Co., 525 Market St., San Francisco.
Truscon Steel Co., 527 Tenth St., San Francisco.
Badt-Palk Co., Call-Post Bldg., San Francisco.

CONDUITS

Garnett Young & Co., 612 Howard St., San Francisco.

CONTRACTORS, GENERAL

Barrett & Hilt, Sharon Bldg., San Francisco.
K. E. Parker Co., Inc., Clunie Bldg., San Francisco.
R. W. Littlefield, 357 12th St., Oakland.
Unit Construction Co., Phelan Bldg., San Francisco.
J. D. Hannab, 142 Sansome St., San Francisco.

R. J. Davis

District Sales Agent

Century

A. C. Motors
and Fans

Complete stocks carried at: 171-173 Second St., San Francisco; 906 So. Hope St., Los Angeles

We have returned to our policy-holders annually for 34 years never less than 30% of the premium as a dividend. Dividends declared during 1920, \$2,730,571.64

AMERICAN MUTUAL LIABILITY INSURANCE CO. OF BOSTON

Assets \$10,959,557.94

Surplus \$1,612,184.22

WORKMEN'S COMPENSATION, AUTOMOBILE, TEAMS AND PUBLIC LIABILITY INSURANCE

BALBOA BLDG.
SAN FRANCISCO

GEORGE W. LINCH,
CALIFORNIA MGR.

L. A. STOCK EXCH. BLDG
LOS ANGELES

ARCHITECTS' SPECIFICATION INDEX—Continued

CONTRACTORS, GENERAL—Continued

John M. Bartlett, 357 Twelfth St., Oakland.
Chas. Stockholm & Son, Monadnock Bldg., San Francisco.

Herbert Beckwith, 323 Newton Ave., Oakland.
Collman & Speidel, 546 Monadnock Bldg., San Francisco.

Clinton Construction Company, 140 Townsend St., San Francisco.

Monson Bros., 1907 Bryant St., San Francisco.
W. C. Duncan & Co., 526 Sharon Bldg., San Francisco.

A. Knowles, Call-Post Bldg., San Francisco.
T. B. Goodwin, 180 Jessie St., San Francisco.

Lange & Bergstrom, Sharon Bldg., San Francisco.
McLeran & Peterson, Hearst Bldg., San Francisco.

Robert Trost, 26th and Howard Sts., San Francisco.
I. M. Sommer, 401 Balboa Bldg., San Francisco.

Del Favero & Rasori, 180 Jessie St., San Francisco.
Jas. L. McLaughlin, 251 Kearny street, San Francisco.

CONTRACTORS' EQUIPMENT

Edward R. Bacon Co., 51 Minna St., San Francisco, and Los Angeles.

Garfield & Co., Hearst Bldg., San Francisco.
Smith, Booth-Usher Co., 60 Fremont St., San Francisco; 228 Central Ave., Los Angeles.

CONVEYING MACHINERY

Meesse & Gottfried, San Francisco, Los Angeles, Portland and Seattle.

CRUSHED ROCK

Coast Rock & Gravel Co., Call-Post Bldg., San Francisco.

DAMP-PROOFING COMPOUND

Armorite Damp Resisting Paint, made by W. P. Fuller & Co., San Francisco.

Gunn, Carle & Co., Inc., 444 First street, San Francisco.
Hill, Hubble & Company, No. 1 Drumm St., San Francisco.

Imperial Waterproofing, mfrd. by Brooks & Doerr, Reed Baxter, agent, Merchants National Bank Bldg., San Francisco.

"Pabco" Damp-Proofing Compound, sold by Paraffine Co., 34 First St., San Francisco.

Lapidolith, manufactured by L. Sonneborn Sons, Inc., San Francisco, Los Angeles, Portland and Seattle.

DOOR HANGERS

Pitcher Hanger, sold by National Lumber Co., 326 Market St., San Francisco.

Reliance Hanger, sold by Waterhouse-Wilcox Co., San Francisco; D. F. Fryer & Co., B. V. Collins, Los Angeles, and Columbia Wire & Iron Works, Portland, Oregon.

Stanley Works, New Britain, Conn. John Rountree, agent, Monadnock Bldg., San Francisco.

Richards-Wilcox Mfg. Co., Underwood Bldg., San Francisco.

DRINKING FOUNTAINS

Haws Sanitary Drinking Faucet Co., 1808 Harmon St., Berkeley, and C. F. Weber & Co., San Francisco and Los Angeles.

Crane Company, San Francisco, Oakland, and Los Angeles.

Pacific Porcelain Ware Co., 67 New Montgomery St., San Francisco.

George H. Tay Company, Mission and Second Sts., San Francisco; 10th and Harrison Sts., Oakland.

Haines, Jones & Cadbury Co., 857 Folsom St., San Francisco.

DUMB WAITERS

Spencer Elevator Company, 166 7th St., San Francisco.

San Francisco Elevator Company, Inc., 860 Folsom street, San Francisco.

M. E. Hammond, Pacific Bldg., San Francisco.

ELECTRICAL CONTRACTORS

Butte Electrical Equipment Company, 530 Folsom St., San Francisco.

Butte Electric & Manufacturing Co., 534 Folsom St., San Francisco.

Brown-Langlais Electrical Construction Co., 213 Minna St., San Francisco.

Central Electric Company, 185 Stevenson street, San Francisco.

NePage, McKenny Co., 589 Howard St., San Francisco.

Liberty Electric Company, 479 Sutter St., San Francisco.

Newbery Electrical Co., 413 Lick Bldg., San Francisco.

Pacific Fire Extinguisher Co., 424 Howard St., San Francisco.

Globe Electric Works, 1959 Mission St., San Francisco.

M. E. Ryan, Redwood City, Calif.

H. S. Tittle, 766 Folsom St., San Francisco.

Spencer Electric Co., 355 12th street, Oakland.

Spott Electrical Co., Sixteenth and Clay Sts., Oakland.

ELECTRIC PLATE WARMER

The Prometheus Electric Plate Warmer for residences, clubs, hotels, etc. Sold by M. E. Hammond, Pacific Bldg., San Francisco.

ELECTRICAL SUPPLIES AND EQUIPMENT

Garnett Young & Co., 612 Howard St., San Francisco.

Butte Electrical Equipment Co., 530 Folsom St., San Francisco.

Electric Outlet Co., Inc., 119 West 40th St., New York.

Safety Electric Company, 56-65 Columbia Square, San Francisco.

Drendell Electrical & Mfg. Co., 1345 Howard St., San Francisco.

R. J. Davis, District Sales Agent, Century A. C. Motors and Fans, 171 Second St., San Francisco.

Western Electric Safety Mfg. Co., Inc., 247 Minna street, San Francisco.

ELEVATORS

Otis Elevator Company, Stockton and North Point, San Francisco.

Spencer Elevator Company, 166 7th St., San Francisco.

San Francisco Elevator Co., 860 Folsom street, San Francisco.

ELEVATOR EQUIPMENT

Elevator Supplies Company, Inc., 186 Fifth St., San Francisco.

KEWANEE
GARBAGE BURNERS
AND
BOILERS

YEOMANS
BILGE PUMPS
EJECTORS
HOUSE PUMPS

OVERHEAD
CARRYING
SYSTEMS

CALIFORNIA HYDRAULIC ENGINEERING & SUPPLY CO., 80 Fremont St., S. F.



TEMPERATURE REGULATION

JOHNSON SERVICE COMPANY

(OF MILWAUKEE — ESTABLISHED 1885)

Manufacturers and Installers of **JOHNSON Heat Humidity CONTROL**

For schools, residences, hospitals, banks, public buildings, also canneries and all kinds of industrial plants—Hot water tank regulators, air and water reducing valves.

Rialto Bldg., SAN FRANCISCO 605 Van Nuys Bldg., LOS ANGELES



ARCHITECTS' SPECIFICATION INDEX—Continued

ENGINEERS—CONSULTING, ELECTRICAL, MECHANICAL

Chas. T. Phillips, Pacific Bldg., San Francisco.
Hunter & Hudson, Rialto Bldg., San Francisco.

ELEVATOR DOOR HARDWARE

Richards-Wilcox Mfg. Co., Underwood Bldg., San Francisco.

ESTIMATOR—BUILDING AND ENGINEERING WORKS

Arthur Priddle, 185 Stevenson street, San Francisco.

FAIENCE TILE

Tropico Potteries, Inc., Glendale, Cal.

FANS AND BLOWERS

Ideal Heating & Engineering Co., 192 Erie St., San Francisco.

John Ringins Co., Inc., 1267 Folsom street, San Francisco.

FENCES—WIRE

Standard Fence Construction Co., 245 Market St., San Francisco, and 310 12th St., Oakland.

FILLING STATION EQUIPMENT

S. F. Bowser & Co., Inc., 612 Howard St., San Francisco.

Wayne Oil Tank & Pump Co., 631 Howard St., San Francisco, 830 S. Los Angeles St., Los Angeles.

FIRE BRICK

Livermore Fire Brick Works, 604 Mission street, San Francisco.

FIRE ESCAPES

Palm Iron & Bridge Works, Sacramento.
Western Iron Works, 141 Beale St., San Francisco.
Golden Gate Iron Works, 1541 Howard St., San Francisco.

FIRE INSURANCE

Bankers & Shippers Insurance Co., Insurance Exchange Bldg., San Francisco.

FIRE PROOFING

American Insulex Company, Berkeley Bank Bldg., Berkeley.

FIRE-PROOF DOORS

Forderer Cornice Works, 269 Potrero avenue, San Francisco.

U. S. Metal Products Co., 330 10th street, San Francisco.

Fire Protection Products Co., 3117 20th street, San Francisco.

FIRE SPRINKLERS—AUTOMATIC

Grinnell Company, 453 Mission St., San Francisco.

Pacific Fire Extinguisher Co., 424 Howard St., San Francisco.

FIRE RETARDING PAINT

The Paraffine Companies, Inc., 34 First St., San Francisco.

FIXTURES—BANK, OFFICE, STORE, ETC.

Home Manufacturing Company, 543 Brannan St., San Francisco.

The Fink & Schindler Co., 218 13th St., San Francisco.

Mullen Manufacturing Co., 64 Rausch St., San Francisco.

C. F. Weber & Co., 985 Market St., San Francisco, and 210 N. Main St., Los Angeles, Cal.

FLOOR TILE

Mangrum & Otter, 827 Mission St., San Francisco.

FLOOR VARNISH

Bass-Hueter and San Francisco Pioneer Varnish Works, 816 Mission St., San Francisco.

Fifteen for Floors, made by W. P. Fuller & Co., San Francisco.

Standard Varnish Works, Chicago, New York and San Francisco.

R. N. Nason & Co., San Francisco and Los Angeles.

L. Sonneborn Sons, Inc., San Francisco, Los Angeles, Portland and Seattle.

FLOORS—HARDWOOD

Oak Flooring Manufacturers' Association of the United States, Ashland Block, Chicago, Ill.

Parrott & Co., 320 California St., San Francisco.

White Bros., Fifth and Brannan Sts., San Francisco.

Strahle Hardwood Company, 511 First street, Oakland.

FLOORS—MASTIC

Hill, Hubbell & Company, No. 1 Drumm St., San Francisco.

FLOORS—DUST PROOF CEMENT

L. Sonneborn Co., United Materials Co., San Francisco agents.

FLUMES

California Corrugated Culvert Co., West Berkeley, Cal.

FLUSH VALVES

National Valve Company, 23-25 Minna St., San Francisco.

FRUIT DRYING MACHINERY

Ideal Heating & Engineering Co., 192 Erie St., San Francisco.

Jas. A. Nelson, 517 Sixth St., San Francisco.

FUEL OIL SYSTEMS

S. T. Johnson Co., 1337 Mission St., San Francisco.

S. F. Bowser & Co., Inc., 612 Howard St., San Francisco.

Wayne Oil Tank & Pump Co., 631 Howard St., San Francisco.

FURNACES—WARM AIR

Mangrum & Otter, 827 Mission St., San Francisco.

Montague Range and Furnace Co., 826 Mission St., San Francisco.

FURNITURE—BUILT-IN

Hoosier Kitchen Cabinet Store, Pacific Bldg., San Francisco.

FURNITURE—SCHOOL, CHURCH, OFFICE, HOUSE, ETC.

Home Manufacturing Company, 543 Brannan St., San Francisco.

C. F. Weber & Co., 985 Market St., San Francisco.

Rucker-Fuller Desk Co., 677 Mission St., San Francisco.

F. W. Wentworth & Co., 539 Market St., San Francisco.

W. & J. Sloane, 216-228 Sutter St., San Francisco.

GARAGE HARDWARE

The Stanley Works, New Britain, Conn., Coast Sale offices, San Francisco, Los Angeles and Seattle, Wash.

Richards-Wilcox Mfg. Co., Aurora, Ill., and Underwood Bldg., San Francisco.

JOHN A. PETERSON, President

B. HEINRICH, Vice-President

SAN FRANCISCO ELEVATOR CO., Inc.

ELEVATORS

Automatic, Electric, Hydraulic, Belt Power, Automatic Dumbwaiters and Handpower Machines. Push Button Passenger Elevators a Specialty

Telephone Kearny 2443

860 FOLSOM STREET, SAN FRANCISCO

HOT WATER ELECTRICALLY

ALL YOU WANT ALL THE TIME THERM-ELECT WATER HEATER for APARTMENT HOUSES, RESIDENCES, ETC.]

ELECTRIC SALES SERVICE COMPANY

2532 Sixth Street, BERKELEY

Phone Berkeley 3070

ARCHITECTS' SPECIFICATION INDEX—Continued

GARBAGE CHUTES AND INCINERATORS

Kerner Incinerator Co., 77 O'Farrell St., San Francisco.

California Hydraulic Engineering & Supply Co., 70-72 Fremont St., San Francisco.

GAS STEAM RADIATORS—FUMELESS, ETC.

Ra-Do Fumeless Gas Radiators, manufactured and sold by Baird-Bailhache Co., 478 Sutter St., San Francisco.

GLASS

American Window Glass Co., represented by L. H. Butcher Co., 862 Mission St., San Francisco. Cobble-dick-Kibbe Glass Co., 175 Jessie St., San Francisco.

Fuller & Goepf, 32 Page St., San Francisco. W. P. Fuller & Company, all principal Coast cities.

GRADING, WRECKING, ETC.

Dolan Wrecking & Construction Co., 1607 Market St., San Francisco.

GRANITE

California Granite Co., Gen. Contractors' Ass'n, San Francisco. Raymond Granite Co., Potrero Ave. and Division St., San Francisco.

GRAVEL AND SAND

Coast Rock & Gravel Co., Call-Post Bldg., San Francisco.

Del Monte White Sand, sold by Del Monte Properties Co., Crocker Bldg., San Francisco.

GYMNASIUM EQUIPMENT

Ellyery Arms Co., 583 Market St., San Francisco. A. G. Spalding & Bros., 625 Market St., San Francisco.

HARDWALL PLASTER

Henry Cowell Lime & Cement Co., San Francisco.

HARDWARE

Joost Bros., agents for Russell & Erwin hardware, 1053 Market St., San Francisco.

The Stanley Works, New Britain, Conn.; Coast sales offices, San Francisco, Los Angeles, and Seattle, Wash.

Corbin hardware, sold by Palace Hardware Co., 581 Market St., San Francisco.

Richards-Wilcox Mfg. Co., Aurora, Ill., Ewing-Lewis Co., 626 Underwood Bldg., San Francisco.

HARDWOOD LUMBER—FLOORING, ETC.

Parrott & Co., 320 California St., San Francisco. White Bros., cor. Fifth and Brannan Sts., San Francisco.

Strable Hardwood Company, First street, near Broadway, Oakland.

HEATERS—AUTOMATIC, GAS, ELECTRIC

Electric Sales Service Co., mfrs. of Therm-elect Water Heater, West Berkeley.

"Humphrey Radiantfire," The General Gas Light Co., 768 Mission St., San Francisco.

Pittsburg Water Heater Co., 478 Sutter St., San Francisco.

George H. Tay Company, Mission and Second Sts., San Francisco; 10th and Harrison Sts., Oakland.

Ra-Do Fumeless Gas Heater, sold by Baird-Bailhache Company, 478 Sutter St., San Francisco.

HEATING AND VENTILATING CONTRACTORS, EQUIPMENT, ETC.

Alex Coleman, 706 Ellis St., San Francisco.

C. A. Dunham Co., Sheldon Building, San Francisco.

Gilley-Schmid Company, 198 Otis St., San Francisco.

Hateley & Hateley, Mitau Bldg., Sacramento. Knittle-Cashel Co., Inc., 1820 Ellis St., San Francisco.

General Boilers Co., 332 Monadnock Bldg., San Francisco.

Mangrum & Otter, 827-831 Mission St., San Francisco.

Moline Heat, Hobart Bldg., San Francisco.

James & Drucker, 450 Hayes St., San Francisco. James A. Nelson, 517 Sixth St., San Francisco.

Ideal Heating & Engineering Co., 192 Eric St., San Francisco.

Illinois Engineering Co., 563 Pacific Bldg., San Francisco.

William F. Wilson Co., 328 Mason St., San Francisco.

Pacific Fire Extinguisher Co., 424 Howard St., San Francisco.

Scott Company, 243 Minna St., San Francisco. Mechanical Engineering & Supply Co., 908 7th St., Sacramento.

George H. Tay Company, Mission and Second Sts., San Francisco; 10th and Harrison Sts., Oakland.

O. M. Simmons Co., 115 Mission St., San Francisco.

HOLLOW TILE BLOCKS

Cannon & Co., plant at Sacramento; office in Chronicle Bldg., San Francisco.

Gladding, McBean & Co., San Francisco, Los Angeles, Oakland and Sacramento.

Los Angeles Pressed Brick Co., Frost Bldg., Los Angeles.

HOSPITAL FIXTURES

Mott Company of California, 553 Mission St., San Francisco.

George H. Tay Company, Mission and Second Sts., San Francisco; 10th and Harrison Sts., Oakland.

HOSPITAL SIGNAL SYSTEM

Chicago Signal Co., represented by Garnett Young & Co., 612 Howard St., San Francisco.

HOTELS

St. Francis Hotel, Powell, Geary and Post Sts., San Francisco.

INGOT IRON

"Armco" brand, manufactured by American Rolling Mill Company, Middletown, Ohio, and 10th and Bryant streets, San Francisco.

INSPECTIONS AND TESTS

Robert W. Hunt & Co., 251 Kearny St., San Francisco.

INSULATION

American Insulex Company, Berkeley Bank building, Berkeley.

John Manville Co., all principal coast cities. L. Sonneborn Sons, Inc., San Francisco, Los Angeles, Portland and Seattle.

"The Perfect Automatic Valve"

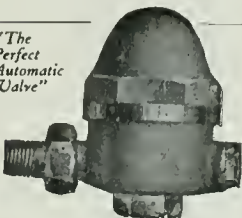

Haines Heating Systems

ASSURE

Heating Satisfaction

O. M. SIMMONS CO.

115 Mission St., San Francisco
Phone: Douglas 5497

CLARENCE E. MUSTO, Pres. JOSEPH B. KEENAN, Vice-Pres. GUIDO J. MUSTO, Sec'y & Treas.

JOSEPH MUSTO SONS-KEENAN CO.Phone Franklin
—6365—**MARBLE**OFFICE AND MILLS:
535-565 North Point St.,
SAN FRANCISCO, CAL.**ARCHITECTS' SPECIFICATION INDEX—Continued****INCINERATORS**

Kerner Incinerator Co., 77 O'Farrell St., San Francisco.

INTERIOR DECORATORSAtherly Bros., 2032 Polk St., San Francisco.
Beach-Robinson Co., 239 Geary St., San Francisco.

Martin & Frederick, 1374 Sutter St., San Francisco.

John Breuner Co., 281 Geary St., San Francisco.
Sonnenschein Bros., 470 Sutter St., San Francisco.The Tormey Co., 1042 Larkin St., San Francisco.
Taylor Galleries, 1818 Harrison street, Oakland and San Francisco.

Freeman Art Shop, 386 Sutter St., San Francisco.

A. Quandt & Son, 374 Guerrero street, San Francisco.

KITCHEN CABINETS

Hoosier Kitchen Cabinet Store (O. K. Brown, Mgr.), Pacific Bldg., San Francisco.

LAMP POSTS, ELECTROLIERS, ETC.

J. L. Mott Iron Works, 553 Mission St., San Francisco.

LANDSCAPE GARDENERS

MacRorie-McLaren Co., 141 Powell St., San Francisco.

LATHING AND PLASTERING

MacGruer & Simpson, Call-Post Bldg., San Francisco.

A. Knowles, Call-Post Bldg., San Francisco.

LATHING MATERIAL

Pacific Materials Co., 525 Market St., San Francisco.

Truscon Steel Co., Tenth St., near Bryant, San Francisco.

LIGHT, HEAT AND POWER

Great Western Power Company, Stockton St., near Sutter, San Francisco.

LIGHTING FIXTURESRoberts Mfg. Co., 663 Mission St., San Francisco.
Perfelite Manufacturing Co., Seattle, Wash.;
San Francisco Representatives, Myers & Schwartz,
75 New Montgomery street, San Francisco;
1119 S. Los Angeles street, Los Angeles.**LIME**

Henry Cowell Lime & Cement Co., 2 Market St., San Francisco.

LINOLEUM

D. N. & E. Walter & Co., 562 Mission St., San Francisco.

The Paraffine Companies, factory in Oakland; office, 34 First St., near Market, San Francisco.

LUBRICATING OIL STORAGE TANKS AND PUMPS

S. F. Bowser & Co., Inc., 612 Howard St., San Francisco

LUMBERDudfield Lumber Co., Palo Alto, Cal.
Hart-Wood Lumber Co., Fifth and Berry Sts., San Francisco.

Pacific Manufacturing Company, San Francisco, Oakland, Los Angeles and Santa Clara.

Pope & Talbot, foot of Third St., San Francisco.

Santa Fe Lumber Co., 16 California street, San Francisco.

Sunset Lumber Company, First and Oak Sts., Oakland.

MAIL CHUTES

American Mailing Device Corp., represented on Pacific Coast by Waterhouse-Wilcox Co., 523 Market St., San Francisco.

MANTELS

Mangrum & Otter, 827-831 Mission St., San Francisco.

MANUAL TRAINING EQUIPMENT

Richards-Wilcox Mfg. Co., Ewing-Lewis Co., 626 Underwood Bldg., San Francisco.

Smith-Booth-Usher Co., San Francisco and Los Angeles.

MARBLE

American Marble and Mosaic Co., 25 Columbus Square, San Francisco.

Joseph Musto Sons, Keenan Co., 535 N. Point St., San Francisco.

Vermont Marble Co., Coast branches, San Francisco, Portland and Tacoma.

METAL DOORS AND WINDOWS

Fire Protection Products Co., 3117 20th St., San Francisco.

Waterhouse-Wilcox Co., Inc., 523 Market St., San Francisco.

U. S. Metal Products Co., 330 Tenth St., San Francisco.

METAL FURNITURE

Forderer Cornice Works, 269 Potrero avenue, San Francisco.

MILL WORKDudfield Lumber Co., Palo Alto, Cal.
Pacific Manufacturing Company, San Francisco, Los Angeles, Oakland and Santa Clara.
National Mill and Lumber Co., San Francisco and Oakland.

The Fink & Schindler Co., 218 13th St., San Francisco.

Frank Portman, 1619-20 Mission St., San Francisco.

Lannom Bros. Mfg. Co., 5th and Magnolia sts., Oakland.

MOTORS AND FANS

R. J. Davis, Dist. Sales Agent Century Motors and Fans, 171 Second St., San Francisco.

OFFICE EQUIPMENTC. F. Weber Co., 985 Market St., San Francisco.
Rucker-Fuller Co., 677 Mission St., San Francisco.

F. W. Wentworth & Co., 539 Market St., San Francisco.

OIL BURNERS

Bunting Iron Works, 1215 First Nat. Bank bldg., San Francisco.

Fess System Co., 220 Natoma St., San Francisco.

S. T. Johnson Co., 1337 Mission St., San Francisco.

T. P. Jarvis Manufacturing Co., 275 Connecticut St., San Francisco.

G. E. Witt Co., 862 Howard St., San Francisco.

KNITTLE-CASHEL CO., Inc.**HEATING CONTRACTORS****STEAM HEATING
HOT WATER HEATING****VENTILATING
POWER PLANTS****GENERAL PIPE WORK
REPAIRING**

1820-22 Ellis Street, San Francisco

Phone West 964

ARCHITECTS' SPECIFICATION INDEX—Continued

OIL STORAGE AND DISTRIBUTING STATIONS

- S. F. Bowser & Co., Inc., 612 Howard St., San Francisco.
 S. T. Johnson Co., 1337 Mission St., San Francisco.
 Wayne Oil Tank & Pump Co., 631 Howard St., San Francisco; 830 S. Los Angeles St., Los Angeles.

ORNAMENTAL IPON AND BRONZE.

- California Artistic Metal and Wire Co., 349 Seventh St., San Francisco.
 Palm Iron & Bridge Works, Sacramento.
 C. J. Hillard Company, Inc., 19th and Minnesota Sts., San Francisco.
 Schrader Iron Works, Inc., 1247 Harrison St., San Francisco.

OVERHEAD CARRYING SYSTEMS

- California Hydraulic Engineering & Supply Co., 70-72 Fremont St., San Francisco.
 Richards-Wilcox Mfg. Co., Aurora, Ill., and Underwood Bldg., San Francisco.

PAINT FOR STEEL STRUCTURES, BRIDGES, ETC.

- The Paraffine Companies, Inc., 34 First St., San Francisco.
 Premier Graphite Paint and Pioneer Brand Red Lead, made by W. P. Fuller & Co., San Francisco.
 Hill, Hubbell & Company, No. 1 Drumm St., San Francisco.
 Wadsworth, Howland Co., makers of Bay State Brick and Cement Coating, Boston, Mass.
 Hambley & Son, Distributors in San Francisco and Los Angeles.

PAINTING, TINTING, ETC.

- Atherly Bros., 2032 Polk St., San Francisco.
 J. F. Wayne Co., 1914 Fillmore St., San Francisco.
 I. R. Kissel, 1747 Sacramento St., San Francisco.
 D. Zelinsky & Sons, San Francisco and Los Angeles.
 The Tormey Co., 681 Geary St., San Francisco.
 Fick Bros., 475 Haight St., San Francisco.
 A. Quandt & Son, 374 Guerrero street, San Francisco.

PAINTS, OILS, ETC.

- Magner Bros., 414-424 Ninth St., San Francisco.
 Bass-Hueter Paint Co., Mission, near Fourth St., San Francisco and all principal coast cities.
 R. N. Nason & Company, San Francisco, Los Angeles, Portland and Seattle.
 W. P. Fuller & Co., all principal Coast cities.
 "Satinette," Standard Varnish Works, 55 Stevenson St., San Francisco.
 Palace Hardware Co., 581 Market St., San Francisco.

PANELS AND VENEER

- White Bros., Fifth and Brannan Sts., San Francisco.

PARTITIONS—FOLDING AND ROLLING

- J. G. Wilson Corporation, 600 Metropolitan Bldg., Los Angeles; Waterhouse-Wilcox Co., Underwood Bldg., San Francisco.

PENCILS

- Eberhard Faber, Monadnock Bldg., San Francisco.

PIPE—STEEL AND WROUGHT IRON

- Western Pipe & Steel Co., 444 Market St., San Francisco; 1758 N. Broadway, Los Angeles.
 George H. Tay Company, Mission and Second Sts., San Francisco; 10th and Harrison Sts., Oakland.

PLAYGROUND APPARATUS

- A. G. Spalding & Bros., 625 Market St., San Francisco.

PLUMBING CONTRACTORS

- Alex Coleman, 706 Ellis St., San Francisco.
 Gilley-Schmid Company, 198 Otis street, San Francisco.
 Hately & Hately, Mitau Bldg., Sacramento.
 Scott Co., Inc., 243 Minna St., San Francisco.
 Wm. F. Wilson Co., 328 Mason St., San Francisco.

PLUMBING FIXTURES, MATERIALS, ETC.

- All-In-One Company, Ochsner bldg., Sacramento.
 California Steam & Plumbing Supply Co., 671 Fifth St., San Francisco.
 Crane Co., San Francisco, Oakland, Los Angeles.
 Gilley-Schmid Company, 198 Otis St., San Francisco.
 Haines, Jones & Cadbury Co., 857 Folsom St., San Francisco.
 H. Mueller Manufacturing Company, 635 Mission St., San Francisco.
 Holbrook, Merrill & Stetson, 64 Sutter St., San Francisco.
 J. L. Mott Iron Works, D. H. Gulick, selling agent, 553 Mission St., San Francisco.
 National Valve Company, 23-25 Minna St., San Francisco.
 Pacific Sanitary Manufacturing Co., 67 New Montgomery St., San Francisco.
 George H. Tay Company, Mission and Second Sts., San Francisco; 10th and Harrison Sts., Oakland.
 Standard Metals Mfg. Co., 1300 N. Main st., Los Angeles.
 West Coast Porcelain Manufacturers, Rialto building, San Francisco.
 Wm. F. Wilson Co., 328 Mason St., San Francisco.

POLES AND PILING

- Sante Fe Lumber Co., 16 California street, San Francisco.

POWER PLANTS

- Knittle-Cashel Co., Inc., 1820 Ellis St., San Francisco.

POWER TRANSMITTING MACHINERY

- Meese & Gottfried, San Francisco, Los Angeles, Portland, Ore., and Seattle, Wash.

PUBLIC QUANTITY SURVEY PLAN

- Arthur Priddle, 185 Stevenson street, San Francisco.

PRELIMINARY ESTIMATES AND VALUATIONS

- Arthur Priddle, 185 Stevenson street, San Francisco.

PUMPS

- Chicago Pump Co., represented by Garnett, Young & Co., 612 Howard St., San Francisco.
 California Hydraulic Engineering & Supply Co., 70 Fremont St., San Francisco.
 Simonds Machinery Co., 117 New Montgomery St., San Francisco.
 Ocean Shore Iron Works, 558 Eighth St., San Francisco.
 George H. Tay Company, Mission and Second Sts., San Francisco; 10th and Harrison Sts., Oakland.

PUMPS—HAND OR POWER, FOR OIL AND GASOLINE

- S. F. Bowser & Co., Inc., 612 Howard St., San Francisco.
 S. T. Johnson Co., 1337 Mission St., San Francisco.
 Wayne Oil Tank & Pump Co., 631 Howard St., San Francisco; 830 S. Los Angeles St., Los Angeles.
 George H. Tay Company, Mission and Second Sts., San Francisco; 10th and Harrison Sts., Oakland.



Yards:
Tracy - Brentwood
Patterson - Newman
California

Phones:
Kearny 2073 - 2074

SANTA FE LUMBER CO.

A. J. RUSSELL, Mgr.

Wholesale and Retail

LUMBER

POLES AND PILING
OIL RIG AND SHIP TIMBERS
SAGINAW SPECIAL SHINGLES

FENCE POSTS
SIMPLEX SILOS
PAPEC ENSILAGE CUTTERS

16 California Street

San Francisco, Calif.

from tree to Consumer

Pine and Redwood Lumber

SASH DOORS AND MILL WORK

SUNSET LUMBER COMPANY

MANUFACTURERS — WHOLESALE AND RETAIL

Main Office and Yards:

FIRST AND OAK STREETS, OAKLAND

Phone Oakland 1820

POPE & TALBOT

Manufacturers, Exporters and Dealers in

Lumber, Timber, Piles, Spars, etc.

Office, Yards and Planing Mills

859-869 THIRD ST., SAN FRANCISCO, CAL.

Mills, Port Gamble, Port Ludlow and Utsalady, Washington

PACIFIC MANUFACTURING COMPANY

MILLWORK, SASH AND DOORS

Hardwood Interior Trim a Specialty

Main Office:

SANTA CLARA, CALIF.

SAN FRANCISCO, 177 Stevenson Street
OAKLAND, 1001 Franklin Street

LOS ANGELES, 908 Washington Building
SAN JOSE, 16 North First Street

ARCHITECTS' SPECIFICATION INDEX—Continued

QUANTITY SURVEYOR FOR CONTRACTORS
Arthur Priddle, 185 Stevenson street, San Francisco.

RADIATOR TRAPS

C. A. Dunham Co., Sheldon Bldg., San Francisco.

REINFORCING STEEL

Edward L. Soule, Rialto Building, San Francisco.
Gunn, Carle & Co., Inc., 444 Market street, San Francisco.

Pacific Coast Steel Co., Rialto Building, San Francisco.

Truscon Steel Co., 527 10th St., San Francisco.

REFRIGERATORS

McCray Refrigerator Company, San Francisco office, 765 Mission street.

REVERSIBLE WINDOWS

Hausser Window Company, 157 Minna St., San Francisco.

ROOFING CONTRACTORS

Bender Roofing Company, Monadnock Bldg., San Francisco.

National Roofing Company, Pacific Roofing Co., C. G. Williams, A. K. Goodmundson, 2140 San Pablo ave., Oakland.

ROOFING AND ROOFING MATERIALS

"Malthoid" and "Ruberoid," manufactured by Paraffine Companies, Inc., San Francisco.

United Materials Co., Crossley Bldg., San Francisco.

RUBBER TILING

New York Belting and Packing Company, 518 Mission St., San Francisco.

SAFETY TREADS

Pacific Materials Co., 525 Market St., San Francisco.

SAND

Del Monte White Sand, Del Monte Properties Co., 401 Crocker Bldg., San Francisco.

SASH CORD

Samson Spot Sash Cord, John T. Rowntree, Pacific Coast Agent, San Francisco and Los Angeles.

SCENIC PAINTING—DROP CURTAINS, ETC.

The Edwin H. Flagg Scenic Co., 1638 Long Beach Ave., Los Angeles.

SCHOOL FURNITURE AND SUPPLIES

C. F. Weber & Co., 985 Market St., San Francisco; 512 S. Broadway, Los Angeles.

Rucker-Fuller Desk Company, 677 Mission St., San Francisco.

SHEATHING AND SOUND DEADENING

Samuel Cabot Mfg. Co., Boston, Mass., agencies in San Francisco, Oakland, Los Angeles, Portland, Tacoma and Spokane.

The Paraffine Companies, Inc., 34 First St., San Francisco.

SHEET METAL WORK

Forderer Cornice Works, 269 Potrero ave., San Francisco.

U. S. Metal Products Co., 330 10th street, San Francisco.

Fire Protection Products Co., 3117 20th street, San Francisco.

SHINGLE STAINS

Bass-Hueter Paint Company, all principal Coast cities.

Cabot's Creosote Stains, sold by Pacific Building Materials Co., 525 Market St., San Francisco.

Fuller's Pioneer Shingle Stains, made by W. P. Fuller & Co., San Francisco.

SHINGLES—STONE

McClenahan Products Co., Inc., 670 Howard St., San Francisco.

SINKS—COMPOSITION

Petrium Sanitary Sink Co., Fifth and Page Sts., Berkeley.

STATIONERY AND SUPPLIES

Schwabacher-Frey Stationery Co., 609 Market St., San Francisco.

H. S. Crocker Co., 565 Market street, San Francisco.

STEEL HEATING BOILERS

California Hydraulic Engineering & Supply Co., 70-72 Fremont St., San Francisco.

General Boilers Co., 332 Monadnock Bldg., San Francisco.

STEEL TANKS, PIPE, ETC.

Ocean Shore Iron Works, 558 Eighth St., San Francisco.

S. T. Johnson Co., 1337 Mission St., San Francisco.

STEEL AND IRON—STRUCTURAL

Central Iron Works, 621 Florida St., San Francisco.

Mortenson Construction Co., 19th and Indiana Sts., San Francisco.

Pacific Rolling Mills, 17th and Mississippi Sts., San Francisco.

Palm Iron & Bridge Works, Sacramento.

U. S. Steel Products Co., Rialto Bldg., San Francisco.

Schrader Iron Works, Inc., 1247 Harrison St., San Francisco.

Union Construction Co., 604 Mission street, San Francisco, and Key Route Fell, Oakland.

Western Iron Works, 141 Beale St., San Francisco.

STEEL PRESERVATIVES

Hill, Hubbell & Company, No. 1 Drumm St., San Francisco.

STEEL ROLLING DOORS

Pacific Building Materials Co., Underwood Bldg., San Francisco.

J. G. Wilson Corporation, 600 Metropolitan Bldg., Los Angeles.

STEEL SASH

Bayley-Springfield solid steel sash, sold by Pacific Materials Co., 525 Market St., San Francisco.

"Fenestra," solid steel sash, manufactured by Detroit Steel Products Company, Detroit, Mich. Direct factory sales office, Foxcroft Bldg., San Francisco.

U. S. Metal Products Company, 330 Tenth St., San Francisco.

Truscon Steel Company, 527 Tenth street, San Francisco.

STORE FRONTS

The Kawneer Manufacturing Company, West Berkeley, California.

Zouri Safety Sash Bars—Cobbedick-Kibbe Glass Company, 175 Jessie St., San Francisco.

STUDDING—FIREPROOF STEEL

Steel Studding Company, 1216 Folsom St., San Francisco.

SUMP AND BILGE PUMPS

California Hydraulic Engineering & Supply Co., 70-72 Fremont St., San Francisco.

MOLINE HEAT

Hobart Building

San Francisco

TELEPHONE SUTTER 3818

ARCHITECTS' SPECIFICATION INDEX—Continued

SWITCHES

Wemco Safety Switch, manufactured and sold by W. E. Mushet Co., 502 Mission St., San Francisco.

Western Electric Safety Switch Co., Inc., 247 Minna street, San Francisco.

THEATER AND OPERA CHAIRS

C. F. Weber & Co., 365 Market street, San Francisco.

Rucker-Fuller Desk Co., 677 Mission street, San Francisco.

THERMOSTATS FOR HEAT REGULATION

Johnson Service, Rialto Bldg., San Francisco.

TILES, MOSAICS, MANTELS, ETC.

Mangrum & Otter, 827-831 Mission street, San Francisco.

TILE FOR ROOFS

Cannon & Co., Sacramento; and 77 O'Farrell St., San Francisco.

Gladding, McBean & Co., Crocker Bldg., San Francisco.

United Materials Co., Sharon Bldg., San Francisco.

TRANSMISSION MACHINERY

Meese & Gottfried Co., San Francisco, Los Angeles and Portland.

VACUUM CLEANERS

United Electric Company, Canton, Ohio, manufacturers of Tucc Cleaners, sold in California by San Francisco Compressed Air Cleaning Co., Stockton and Sutter Sts., San Francisco

VALVES—PIPES AND FITTINGS

California Steam & Plumbing Supply Co., 671 Fifth St., San Francisco.

Crane Radiator Valves, manufactured by Crane Co., Second and Brannan Sts., San Francisco.

National Valve Company, 23-25 Minna St., San Francisco.

Grinnell Co., 453 Mission St., San Francisco.

O. M. Simmons Co., 115 Mission St., San Francisco.

H. Mueller Mfg. Co., 635 Mission street, San Francisco.

W. E. Mushet Co., 502 Mission St., San Francisco

George H. Tay Company, Mission and Second streets, San Francisco; 10th and Harrison streets, Oakland.

Shroeder Direct Flush Valves, mfrd. by Standard Metals Mfg. Co., 1300 N. Main street, Los Angeles.

VALVE PACKING

N. H. Cook Belting Co., 317 Howard St., San Francisco.

Everlasting Blow-off Valves. General Machinery and Supply Co., 39 Stevenson street, San Francisco.

VARNISHES

Bass-Hueter Paint Company, Mission, near 4th street, San Francisco, and all principal coast cities.

W. P. Fuller Co., all principal Coast cities.

R. N. Nason & Co., San Francisco, Los Angeles, Portland and Seattle.

Standard Varnish Works, 55 Stevenson St., San Francisco.

VENETIAN BLINDS, AWNINGS, ETC.

C. F. Weber & Co., 985 Market St., San Francisco.

Western Blind & Screen Co., 2702 Long Beach Ave., Los Angeles.

VITREOUS CHINAWARE

Pacific Porcelain Ware Company, 67 New Montgomery St., San Francisco.

West Coast Porcelain Manufacturers, Rialto Building, San Francisco.

WALL BEDS, SEATS, ETC.

Marshall & Stearns Co., 1154 Pbelan Bldg., San Francisco.

WALL BOARD

"Amiwood" Wall Board, manufactured by The Paraffine Companies, Inc., 34 First St., San Francisco.

WALL PAINT

Nason's Opaque Flat Finish, manufactured by R. N. Nason & Co., San Francisco, Portland and Los Angeles.

San-A-Cote and Vel-va-Cote, manufactured by the Brininstool Co., Los Angeles.

WALL PAPER AND DRAPERIES

Beach-Robinson Co., 239 Geary St., San Francisco.

The Tormey Co., 681 Geary St., San Francisco.

W. & J. Sloane, 216-228 Sutter St., San Francisco.

Uhl Bros., San Francisco.

WATERPROOFING FOR CONCRETE, BRICK, ETC.

Armorite Damp Resisting Paint, made by W. P. Fuller & Co., San Francisco.

Bay State Brick & Cement Coating, manufactured by Wadsworth, Howland Co., Boston; Hambley & Son., Distributors for Northern and Southern California.

Gunn, Carle & Co., Inc., "Hydrate," 444 Market street, San Francisco.

Imperial Waterproofing, manfrd. by Brooks & Doerr, Reed Baxter, agent, Merchants National Bank Bldg., San Francisco.

Pacific Materials Co., 525 Market St., San Francisco.

Samuel Cabot Mfg. Co., Boston, Mass., agencies in San Francisco, Oakland, Los Angeles, Portland, Tacoma and Spokane.

WATER SUPPLY SYSTEMS

Kewance Water Supply System—Simonds Machinery Co., agents, 117 New Montgomery St., San Francisco.

Smith-Booth-Usher Co., San Francisco and Los Angeles.

Baird-Bailhache Co., 478 Sutter street, San Francisco.

WHEELBARROWS—STEEL

Western Iron Works, Beale and Main Sts., San Francisco.

WHITE ENAMEL

"Gold Seal," manufactured and sold by Bass-Hueter Paint Co. All principal Coast cities.

"Silkenwhite," made by W. P. Fuller & Co., San Francisco.

"Satinette," Standard Varnish Works, 55 Stevenson St., San Francisco.

WINDOW SASH CORD

Sampson Spot Cord, John T. Rowntree, Pacific Coast agents, San Francisco and Los Angeles

WINDOWS, REVERSIBLE, CASEMENT, ETC.

Hauser Window Co., 157 Minna St., San Francisco.

The Kawneer Company, West Berkeley, California. (Simplex Fixtures.)

J. G. Wilson Corporation, 600 Metropolitan Bldg., Los Angeles; Waterhouse-Wilcox Co., Underwood Bldg., San Francisco.

WIRE FENCE

Standard Fence Co., 245 Market street, San Francisco; and 310 12th street, Oakland.

WOOD MANTELS

Fink & Schindler, 218 13th St., San Francisco.

Mangrum & Otter, 827 Mission St., San Francisco.

W. E. JOHNSTON

V. A. ANDERSON

Life Insurance Engineers

Submit your INSURANCE PROBLEMS to us.

210 Crocker Building, San Francisco

Phone Kearny 4048

MOTT PLUMBING FIXTURES

Architects and their clients are invited to visit our Showrooms, 553-555 Mission Street, San Francisco; D. H. Gulick, Sales Agent. Los Angeles Office, 1001 Central Building; J. R. Mayhew, Sales Agent.

Mott Company of California

MUELLER — BRASS GOODS

Recognized as the Standard of excellence in plumbing. It pays to use them, and other **Mueller** Brass Goods. *The first cost is practically their last cost.*

H. Mueller Mfg. Co.

635 MISSION STREET, SAN FRANCISCO, CAL.

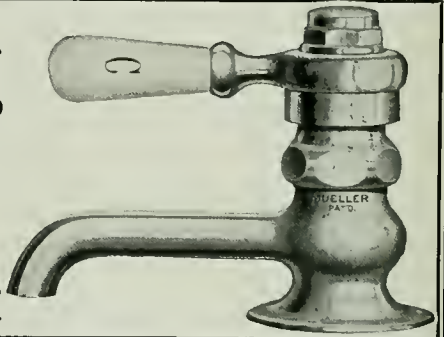

STORM KING and AMERICAN WARM AIR FURNACES

FURNACE FITTINGS AND REPAIRS

Montague Range & Furnace Company

327-329 JESSIE STREET

Phone Garfield 1422

826-830 MISSION STREET

SAN FRANCISCO, CALIF.

**DON'T NEGLECT YOUR HEATING SYSTEM.
THE BEST IS NONE TOO GOOD!**

All kinds of Galvanized Iron Work — Furnaces, Pipes, Ventilators — Sheet Metal for Planing Mills, Fruit Dryers, Rice Mills. Kitchen Equipment, including Steam Tables, Sinks, Canopies, Urn Stands, Etc.

JAMES A. NELSON

Heating and Ventilating Contractor

Phone, Garfield 1959

517-519 SIXTH ST., SAN FRANCISCO

OAK FLOORS

(For Everlasting Economy)

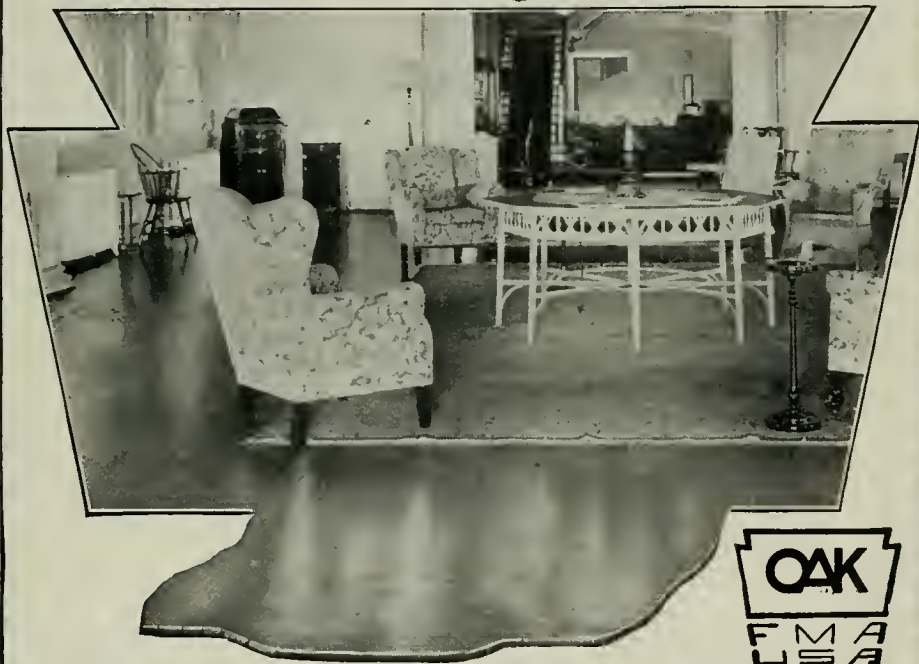

What This Master Trade-Mark Means to You and to Your Clients

It is, of course, unnecessary to inform you of the many superiorities of Oak Flooring itself—its beauty, durability and ease in cleaning, its sanitary advantages and the greater cash value it gives property.

But it is well to remind you occasionally that this trade-mark means Oak Flooring of the highest quality.

It is not an individual manufacturer's brand, but denotes Oak Floor-

ing that has been inspected and passed by an association of manufacturers.

You are always right when your specifications call for this keystone trade-mark, stamped on every stick.

Our three free booklets, in colors, contain much information about Oak Flooring of interest to you as a professional man. Write for them today.



See page 389, Sweet's Architectural Catalogue, 15th Edition, for specifications.

OAK FLOORING *MERESSON*
1036 Ashland Block, Chicago, Ill

VICTORY-FORSTER

Sanitary Water Closet Waste Connections

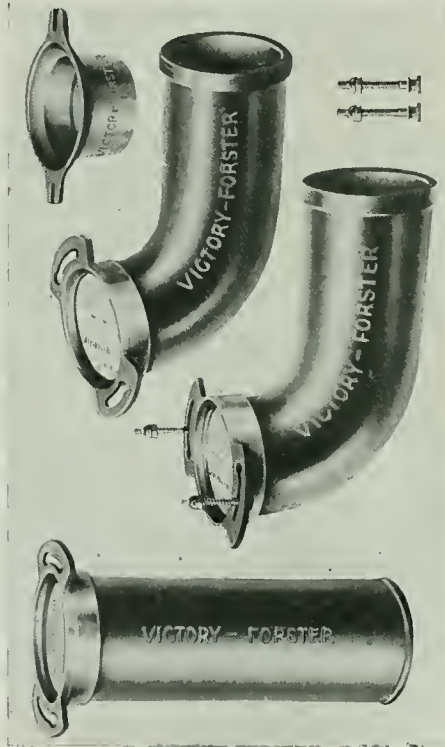

A Clean, Sanitary Fitting, Easily and Quickly Installed.

NO WIPED JOINTS REQUIRED.

For Sale by
All Plumbing Jobbers

A descriptive booklet will be mailed on request.

Manufactured by

VICTORY MANUFACTURING CO.

423½ Monadnock Building

San Francisco, Calif.

When writing to Advertisers please mention this magazine.



This woodland scene is one of a series of sketches drawn for Eberhard Faber by the World renowned artist, Karl Hassmann of the Austrian Academy of Vienna.

On this particular sketch two grades of Van Dyke pencils were used:—

VAN DYKE 6B (softest and blackest)

VAN DYKE HB (soft)

VAN DYKE

DRAWING PENCIL

A dependable drawing pencil with a smooth and lasting lead is not a luxury, it is an essential to those who value good work.

It is for this reason that artists, architects and draftsmen use Eberhard Faber Van Dyke Drawing Pencils.

16 perfectly graded degrees of smooth lasting lead from 6B softest to 8H hardest.

For samples or further information apply to your stationer or address us at:

37 Greenpoint Avenue, Brooklyn, New York

EBERHARD FABER

“The Oldest Pencil Factory in America”

NEW YORK





Brininstool

San - a - Cote

(GLOSS—Can be Scrubbed)

AN INTERIOR WALL FINISH

For bath rooms, kitchens, hospitals, schools, office and public buildings. Ask dealers, owners, architects and contractors about this durable, sanitary, washable, economical wall covering. Brininstool makes a paint for every purpose, and every can purposely good.

THE BRININSTOOL CO., LOS ANGELES

COLOR GRINDERS AND PAINT MANUFACTURERS

Distributors—The Brininstool Co., 1174 Phelan Bldg., San Francisco, Cal.; The Brininstool Co., 222 Abington Bldg., Portland, Ore.; Schutz Paint Co., Fresno, Cal.; Schneider, Chappell & Jones, Sacramento, Cal.; Salt Lake Glass & Paint Co., Salt Lake City, Utah; Griffin Paint Co., Ogden, Utah; Campbell Hardware Co., First and Madison Sts., Seattle, Wash.; Imperial Valley Hardware Co., El Centro, Calexico, Imperial, Brawley, Seeley, Cal.; Spokane Hardware Co., Spokane, Wash.; Continental Paint Company, 328 South First St., San Jose, Cal.; Los Angeles Wallpaper & Paint Co., 525 So. Main St., Los Angeles, Cal.; H. A. Berger, 3388 13th St., San Diego, Cal.; H. L. Christian, Blythe, Cal.; Ezra Thayer, Phoenix, Ariz.; Miami Lumber & Supply Co., Miami, Ariz.

RELIANCE BALL BEARING DOOR HANGERS

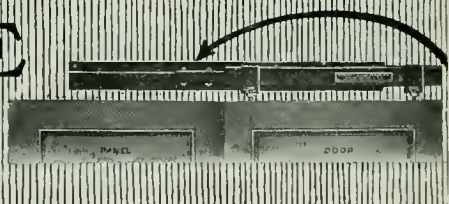

To get as near perfection as possible, use

RELIANCE "HANGERS" and "Reliance-Grant" Controllers

These insure fast service, practically noiseless and slamless doors.

Reliance-Grant Elevator Equipment Corp'n

PARK AVENUE AND 40TH STREET, NEW YORK

PACIFIC COAST AGENTS

Waterhouse-Wilcox Co.
Columbia Wire & Iron Works
D. E. Fryer & Company

San Francisco and Los Angeles, Cal.
Portland, Ore.
Seattle, Spokane, Tacoma, Wash. and Great Falls, Mont.

WE MAKE THE FOLLOWING

SCULPTURED BRONZE
ENTRANCE DOORS,
BRONZE MAUSOLEUM DOORS,
MONUMENTAL BRONZE WORK,
BANK COUNTERS,
MEMORIAL
TABLETS,
CREMATORY
URNS,
STATUES,
FIGURES
PORTRAITS

ECCLESIASTICAL METAL
WORK,
ELECTRIC LIGHT STANDARDS,
CAST BRONZE AND IRON
LANTERNS,
FOUNTAINS,
SUN DIALS,
CHANDELIERS,
BULLETIN
BOARDS,
MANTELS,
VASES.

THE
AMERICAN ART
METAL WORKS
A WATERHOUSE-WILCOX COMPANY
EXECUTORS
OF
HIGH GRADE WORK
IN
BRONZE BRASS
IRON & COMPO

13 GRACE ST

SAN FRANCISCO

PHONE MKT 1404



FROM the Forum of Rome to the modern Seats of Justice, man's endeavor had ever led him to express his ideals in public buildings. How well he has succeeded, is best shown in the above edifice.

WHEN Mr. R. A. Herold of Sacramento was commissioned to plan this courthouse for Sacramento County his problems were many and serious. His mastery of these, requires no comment.

THE courthouse of Sacramento County demonstrates the ideals of this community. This splendid structure in no uncertain manner bespeaks the character of the citizenry that made it possible.

*Fuller's Washable Wall Finishes
Fuller's Varnishes*



W. P. FULLER & CO.

"Since '49"

CANNON & CO.

Clay Products

Denison Interlocking Tile

Face Brick

Hollow Tile

Roof and Floor Tile

Factory and General Offices:
SACRAMENTO, CALIFORNIA

Highest Standard of Quality

Complete and Dependable Service

TROPICO POTTERIES, Inc.



Successors to
PACIFIC MINERALS AND CHEMICAL COMPANY

GLENDALE, CALIF.

ARCHITECTURAL TERRA COTTA

VITRIFIED CLAY SEWER PIPE
TERRA COTTA FLUE LINING
TERRA COTTA CHIMNEY PIPE

FAIENCE TILE
DRAIN TILE
WATER PIPE

GLADDING, McBEAN & CO.

MANUFACTURERS CLAY PRODUCTS

GROCKER BUILDING, SAN FRANCISCO

WORKS, LINCOLN, CAL.



The HUMPHREY
Radiantfire

THE Humphrey Radiantfire not only increases the standard of comfort in the home, but considerable economy in building costs can be effected in proposed building schemes or single houses.

The Humphrey Radiantfire has been constructed especially with this end in view.

It provides an almost complete system for the price of one heavy masonry fireplace.

A simple ventilating flue takes the place of brick chimneys. Produces wholesome radiant heat. Saves the expense of operating the main heating plant in the spring and fall.

A practical demonstration can be had in your own city by our local representative. Many styles and sizes to select from.

Special inducement to builders and contractors.

The General Gas Light Co.

New York

Kalamazoo

San Francisco



PIPE
 Valves & Fittings
STEAM & WATER SUPPLIES
 Heating Material
PLUMBING GOODS
 Pumps

GEORGE H. TAY COMPANY
SAN FRANCISCO OAKLAND
 MISSION & SECOND STS. TENTH & HARRISON STS.
 TELEPHONE DOUGLAS 2240 TELEPHONE LAKESIDE 4200

Ford

Whether for commercial purposes or pleasure, the Ford car will answer any requirement. It has proven its worth in every field of endeavor.

For eighteen years we have catered to the wants of the Ford buying public.

We can offer you the benefits of that long experience by giving you the acme of service through our coastwise organization.

William L. Hughson Co.

Since 1903

Geary at Van Ness, San Francisco

Prospect 607



Seattle

Portland

Oakland

Los Angeles

San Diego

THE HOME of BYBAMOPA WARE

You are cordially invited to visit the

**FREEMAN
ART SHOP**

Where there is displayed only the unusual and exclusive things in Lamp Shades, Mirrors, Candle Sticks, Candles, Book Ends, Oriental Rugs, Pottery, Bronzes, Solid Mahogany Furniture, Oil Paintings, Pastels, Fine Prints, Greeting Cards, Picture Framing.

386 SUTTER STREET, at Stockton
Interior Decorators

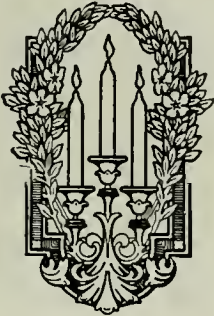

Beach-Robinson Co.

Decorators and Furnishers

Carpets

Draperies

Furniture

Rugs

Wall Paper

Ranson E. Beach

239 Geary Street, 3d Floor

Union Square

Phone, Sutter 580

San Francisco, Cal.



ADD CHEER and COMFORT

to the Home by having a

WELL DESIGNED INTERIOR

Before Completing Your Plans, CONSULT

SONNENSCHN BROS.

INTERIOR DECORATORS

Furniture and Draperies Made to Order

Factory

718 NATOMA ST., Phone Market 1145

Show and Salesroom

470 SUTTER ST., Phone Kearny 2051



TAYLOR GALLERIES

with J. Llewellyn Co.

Artistic Interiors

SPECIAL FURNITURE DRAPES - WALL PAPER

1635 Broadway, Oakland, Calif.

Phone Oakland 1108

The GOLD MEDAL MAIL CHUTE



INSTALLED IN
THE NEW
SAN FRANCISCO
CITY HALL
AND THE
WHITE MARBLE
MERRITT
BUILDING,
LOS ANGELES

Given highest award at
Panama - Pacific Interna-
tional Exposition, 1915.

Waterhouse-Wilcox Co.

California
Representatives

523 Market Street
SAN FRANCISCO

331 E. 4th Street.
LOS ANGELES

F. T. CROWE & CO.
Seattle, Wash.

THE J. McCracken Co.
Portland, Oregon

American Mailing
Device
Corporation

EASY TO LAY
Great quantities of Clinton Electrically Welded Fabric can be laid in a very short time with absolute assurance that every strand of wire is in its proper position. It eliminates all the cost and trouble of spacing and wiring loose rods.

L. A. NORRIS COMPANY
140 Townsend St., San Francisco
Phone Kearny 5375

CLINTON

Electrically Welded Wire Fabric

McCRAY REFRIGERATORS FOR ALL PURPOSES

It is our particular desire to impress the Architects of America with the fact that McCray builds refrigerators for all purposes. Thousands of fine residences, hotels, clubs, restaurants, factory cafeterias, hospitals, stores and markets depend on McCray for efficient, economical refrigerator service.

McCRAY REFRIGERATOR CO.
765 Mission Street, San Francisco, Calif.
Home Office and Factory
Kendallville, Ind

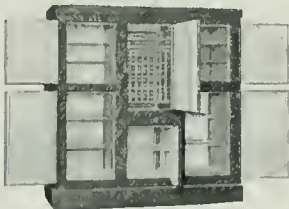

YOU KNOW that a building should be watertight and

WE KNOW that it can be made so with

IMPERIAL WATERPROOFING

LOOK FOR  THE LABEL

If your building is leaking through the walls or around the windows, or if the Basement walls are wet below ground — call up SUTTER 978.

IMPERIAL WATERPROOFING is manufactured by BROOKS & DOERR, 460 7th St., San Francisco

WATEREX REED BAXTER DISTRIBUTOR

1002-04 Merchants National Bank Building,
Phone Sutter 978
SAN FRANCISCO, CAL.
3419 Broadway, OAKLAND, CAL.

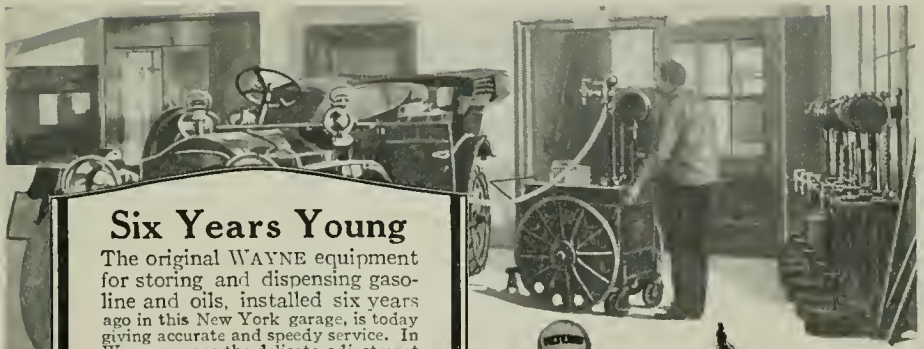

Six Years Young

The original WAYNE equipment for storing and dispensing gasoline and oils, installed six years ago in this New York garage, is today giving accurate and speedy service. In Wayne pumps the delicate adjustment essential for accuracy is combined with a durability that assures satisfaction for years and years.

There is a Wayne System for every need of the public garage. The service of Wayne engineers in advising and planning is yours without cost or obligation.

Wayne Oil Tank & Pump Co.
746 Canal St., Ft. Wayne, Ind.

San Francisco Office
631-633 Howard St.
Phone Garfield 1350

Los Angeles Office
830 S. Los Angeles St.
Phone Main 1600

Wayne
REG. U.S. PAT. OFF.
TRADE MARK
Liquid Storage Systems



Cut No. 280
One-gallon gasoline



Cut No. 230
For Gas and Oil



Cut No. 200
Lubricating oils

DEL MONTE & FAN SHELL BEACH WHITE SAND

With our WASHING and DRYING PLANT in full operation, we can now ship promptly above SANDS fresh water washed, and steam dried, or direct from pits.

Del Monte Properties Company

Phone Sutter 6130 401 Crocker Building

San Francisco

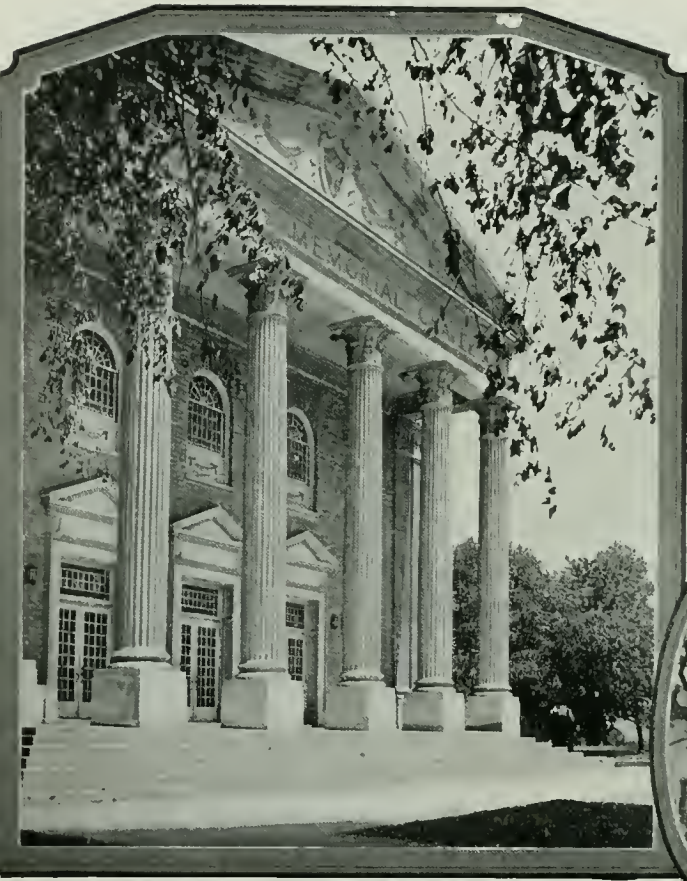

LAURENCE MEMORIAL CHAPEL, Lawrence College, Appleton, Wisconsin. Messrs. Childs & Smith, Chicago, Architects; C. R. Meyer & Sons Co., Oshkosh, Wis., Contractors. Plaster Work by Stillman-Paine, Milwaukee. Old Colonial treatment with a portico of Corinthian columns and surmounted by a tower inspired by those of Sir Christopher Wren.



*"Most Satisfactory Building
of its Kind in America"*

THUS have such authorities as President Taft and Bishop Nicholson designated Lawrence Memorial Chapel, built in 1917 and seating 2,300.

Medusa Stainless White Cement was used in the entire outside finish. The imposing columns along the portico are of Medusa Gray and White Cement. The chaste, beautiful decorative work is of cast cement, approximating the appearance of genuine cut stone.

For immediate beauty and permanent effects in stucco and all ornamental cement work, architects should specify "Medusa Stainless White Cement, *Waterproofed*." Our White

not only retains its freshness remarkably, but may be renewed whenever soiled by exposure, simply by scrubbing with soap and water.

The addition of Medusa Waterproofing renders the mass impermeable to moisture, for all time. We furnish Medusa Waterproofing in powder or paste, or ready mixed in correct proportions with Medusa Stainless White Cement.

Interesting literature gladly sent upon request. The Sandusky Cement Company, Department P, Cleveland, Ohio. Manufacturers of Medusa Stainless White Cement (Plain or Waterproofed) and Medusa Waterproofing (Powder or Paste.)

PACIFIC COAST DISTRIBUTORS—Pacific Materials Co., San Francisco, Cal. Riverside Portland Cement Co., Los Angeles, Cal.
A. McMillan & Company, Portland, Ore. Galbraith & Company, Seattle, Wash.

MEDUSA STAINLESS WHITE CEMENT *Waterproofed*



HOUSE DOOR HARDWARE THAT SATISFIES

THE use of sliding doors in better homes is steadily increasing.

The way for you to turn this increase in demand to real profits for yourself is to sell Richards-Wilcox sliding door hardware.

Furnished for house doors, garage doors, warehouse doors, barn doors, and any parts of door construction where door hangers are employed.

If you are not fully acquainted with the full Richards-Wilcox line, send for our latest catalogue.



Richards-Wilcox Mfg. Co.

A Hanger for any Door that Slides.
 CHICAGO ST. LOUIS AURORA, ILLINOIS, U.S.A. BOSTON
 LOS ANGELES PHILADELPHIA LONDON, ONT. MINNEAPOLIS SAN FRANCISCO



SILENT CALL

HOSPITAL SIGNAL SYSTEMS

SAFE - SANE - SURE

CHICAGO SIGNAL CO.

GARNETT YOUNG and COMPANY

Pacific Coast Sales Engineers

612 Howard Street, San Francisco

SEATTLE

LOS ANGELES

PORTLAND



Pitcher Sliding Door in Living Room

Pitcher's Disappearing Doors

Adjustable Hangers and Frames meet the demand for Appearance, Quietness and Durability.

MANUFACTURED BY

**National Mill and
Lumber Company**

318 Market Street
SAN FRANCISCO

Your Client, Mr. Architect Demands

Snow White Brilliance

Upon a Smooth Surface

☞ Petrium Sanitary Sinks answer every requirement. They are non-porous, non-absorbent and lye-proof. There are no crevices or corners to catch the dirt and grease. ☞ Therefore Specify this sink.

☞ Can be installed in any home or apartment — new or old. A California product.

Send for our Booklet and Price List

**Petrium Sanitary Sink
Company**

Factory and Office, West Berkeley



When writing to Advertisers please mention this magazine.



Specify

THIS

Kind



DO more than specify fixtures that harmonize. Recommend the type that not only harmonizes but also gives more light at less expense.

Perfeclite fixtures do this. They mark a new era in illuminating progress. Because of their novel patented features, they more nearly recreate north daylight than any other type made. The patented battery of mirrors shower a wide area with a light so brilliant that fewer fixtures are required to illuminate a given area.

Perfeclite superiority is the result of many unusual features. Know what these are by visiting our showrooms. We have a type for every commercial or residential need. An art catalog is ready for you. *Send for it today!*

MYERS & SCHWARTZ

72 New Montgomery St.
San Francisco, California
Phone Sutter 6178

1119 So. Los Angeles St.
Los Angeles, California
Phone 15466



FULLER & GOEPP

32 Page Street, San Francisco. Telephone Market 499
PRIVATE EXCHANGE CONNECTING ALL DEPARTMENTS

MANUFACTURERS OF

MIRRORS, ART AND LEADED GLASS

Dealers in **WHITE** Glass for Table Tops, Counter Tops, Sink
Backs Etc. Complete Stock — Prompt Deliveries.

Passenger and Freight Elevators



"MADE IN SAN FRANCISCO"

Factory and Warehouse, 166-180 Seventh
Street, San Francisco. Phones: - Market
1534 and 1535

SPENCER ELEVATOR COMPANY



RA-DO ^{FUMELESS} GAS RADIATORS

ALL CAST IRON—3 Sizes (3, 5, and 7 Sections)

The Ideal "Year-Round" Heating System
For The Home—New or Old

Easiest and Cheapest to Install
Lowest Operating Cost

BAIRD - BAILHACHE COMPANY
MANUFACTURERS

478 Sutter St., San Francisco

'Phone Sutter 6858

OLD MISSION PORTLAND CEMENT COMPANY



Each shipment of "OLD MISSION" Portland Cement is guaranteed not only to equal but to surpass all requirements of the standard specifications for Portland Cement as adopted by the U. S. Government and by the American Society for Testing Materials. A Guarantee Certificate is mailed with the bill of lading of each car, giving number of car, date packed, and number of barrels, over the signature of the chief chemist.

8000 SACKS DAILY

SALES OFFICE:

MILLS BLDG., SAN FRANCISCO

PHONE SUTTER 3075

PLANT:

SAN JUAN, CAL.



Architects make no mistake specifying

“FYER-WALL”

ALL METAL DOORS AND SHUTTERS

Inspected and Labeled by Underwriters' Laboratories

A Fireproof Door for Factories, Warehouses, Power Plants, etc. Cheapest and best fire door on the market.

FIRE PROTECTION PRODUCTS COMPANY

FIRE DOORS — KALAMEIN — GENERAL SHEET METAL WORK

3117-3119 Twentieth Street, San Francisco

Phone Mission 2607



Keep Down Insurance Premiums

SPECIFY

FIRE DOORS

Standard Automatic Sliding or Swinging
Tested and Labeled by the Underwriters' Laboratories.

UNDERWRITERS WINDOWS
STEEL SASH

U. S. METAL PRODUCTS CO.

330 Tenth Street, San Francisco

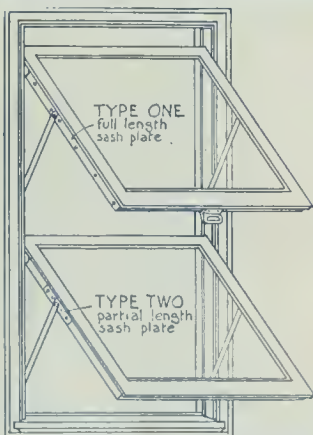

Hauser Window Company

The Ideal Window is one that will operate in any size frame—wood or metal—the HAUSER is such a window — easy to install — a positive protection against rain, dust and wind.

Hauser Reversible Windows

OFFICE AND FACTORY

157 Minna St. (Phone Kearny 3706) San Francisco

**BUILDING FOR CULBERTSON
REALTY COMPANY, SPOKANE,
WASHINGTON**

G. A. PEHRSON, *Architect*
E. J. RINER, *Construction Mgr.*



MICHIGAN MAPLE FLOOR-
ING laid in this building
insures a floor covering in har-
mony with the steel and brick
structure containing it.

WOLVERINE MAPLE FLOOR-
ING is specified by architects
for department stores because
it is a trade-mark of quality.



**STRABLE
HARDWOOD CO.**

First Street, between Washington and Clay
OAKLAND, CALIFORNIA

USE
"MURPHY'S"
 VARNISHES AND ENAMELS
 "QUALITY UNEXCELLED"

UHL BROS., Inc. Write for Prices
 and Color Cards

SEATTLE

LOS ANGELES

PORTLAND

SAN FRANCISCO

OAKLAND

Insulex

This new heat insula-
 tion not only excels in
 durability and efficiency
 as a steam pipe cover-
 ing but is especially
 adaptable to refrigera-
 tion practice.

AMERICAN INSULEX COMPANY
 204 BERKELEY BANK BUILDING, BERKELEY Phone Berkeley 641

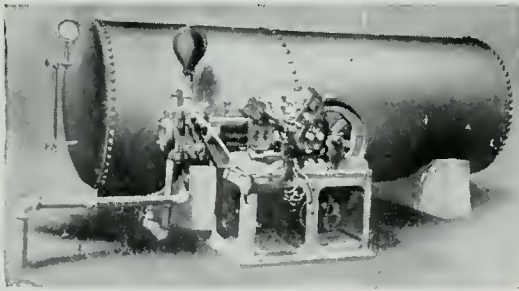

Kewanee Water System

Maintain your own Plant.
 Small Operating Expense.
 A Perfect Water Supply to
 Country Homes, Hotels
 and Parks.

Simonds Machinery Co.

117-121 Montgomery Street
 SAN FRANCISCO
 Phone Kearny 1457



Pack your Radiator Valves with
Palmetto Twist Packing

It can be unstranded to fit any
 size valve. It does not get hard.

H. N. COOK BELTING CO.

401-433 Howard St. San Francisco, Cal.

WESTERN
VENETIAN BLINDS
CORPORATION

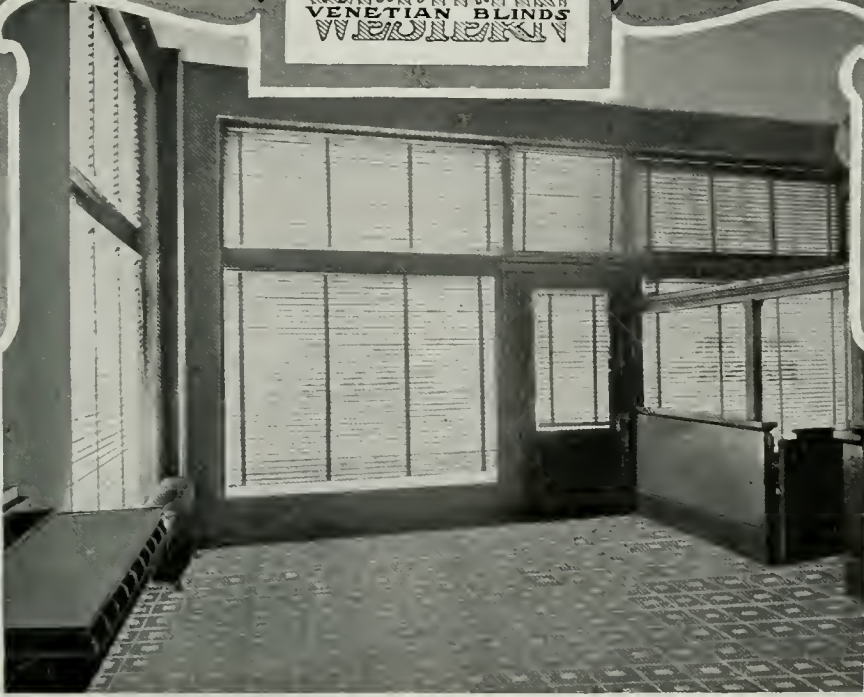

INTERIOR - FARMERS STATE BANK, CHICKASHA, OKLA.
SHOWING WESTERN VENETIAN BLINDS ON WINDOWS -

INDIRECT DAYLIGHT
~ for Banking Rooms ~

From Coast to Coast
WESTERN VENE-
TIAN BLINDS are
satisfactorily serving hun-
dreds of modern banks,
office buildings, schools,
etc.



WILDWOOD, N. J.



CLEARWATER, FLA.



MOUNDRIDGE, KAN.



LOS ANGELES, CAL.



NEW FRANKLIN, MO.



INDIANAPOLIS, IND.

*Let us send you illustrated booklets and general
details and specifications.*

WESTERN BLIND & SCREEN CO.
27th AND LONG BEACH AVE.
LOS ANGELES, CAL.

United States Steel Products Co.

Rialto Bldg., San Francisco

SELLERS of the products of the American Bridge Co., American Sheet and Tin Plate Co., American Steel and Wire Co., Carnegie Steel Co., Illinois Steel Co., National Tube Co., Lorain Steel Co., Shelby Steel Tube Co., Tennessee Coal, Iron and Railroad Co., Trenton Iron Co.

MANUFACTURERS OF

Structural Steel for Every Purpose—Bridges, Railway and Highway—"Triangle Mesh" Wire Concrete Reinforcement—Plain and Twisted Reinforcing Bars—Plates, Shapes and Sheets of Every Description—Rails, Splice Bars, Bolts, Nuts, etc.—Wrought Pipe, Trolley Poles—Frogs, Switches and Crossings for Steam Railway and Street Railway—"Shelby" Seamless Boiler Tubes and Mechanical Tubing—"Americore" and "Globe" Rubber Covered Wire and Cables—"Reliance" Weatherproof Copper and Iron Line Wire—"American" Wire Rope, Rail Bonds, Springs, Woven Wire Fencing and Poultry Netting—Tramways, etc.

United States Steel Products Co.

OFFICES AND WAREHOUSES AT

San Francisco - Los Angeles - Portland - Seattle



Specify **BOWSER**

ESTABLISHED 1885

Thirty-five years ago Bowser blazed the trail to efficient gasoline and oil storage and handling. Today Bowser offers accurate, economical and safe equipment for solving all gasoline and oil storage and service problems—backed by those thirty-five years experience. Whether it's in a garage, a railroad, factory or dry cleaning plant, you are serving your client best when you specify Bowser Equipment.

—Write for Illustrated Booklet A-03—

S. F. BOWSER & COMPANY, Inc.

1303 Creighton Ave., FORT WAYNE, INDIANA
Sales Offices (with Service Departments) throughout the United States and in Principal cities of the World.

612 Howard Street,
San Francisco, Calif.

1225 So. Olive Street,
Los Angeles, Calif.

LONDON

PARIS

HAVANA

SYDNEY



Cabot's Old Virginia White on Siding and Trim

Cabot's Old Virginia White on Trim

Morrow & Garren, Architects, San Francisco

CABOT'S OLD VIRGINIA WHITE—The Modern Architectural Outside White

The clean, brilliant "whitewash white" effect of Old Virginia White has real distinction. It is a softer and yet a brighter white than paint, and its texture and color-values are essentially different in character from the heavy, hard paint coating. This makes it especially appropriate for the modern "Colonial," because it gives the house at once the aspect of well-groomed old age—a result that it would take years to accomplish with paint.

CABOT'S OLD VIRGINIA TINTS

This softness and textural quality have led many of the leading architects to call for the same compound in tints, and Cabot's Old Virginia Tints are now made in a wide variety of delicate shades. The tones are almost pastel-like in quality, and the effects produced are most unique and pleasing. Send for Samples.

SAMUEL CABOT, Inc., Manufacturing Chemists, BOSTON, MASS.

Pacific Building Materials Co., San Francisco

S. W. R. Dully, Seattle

Waterhouse-Wilcox Co., Los Angeles

Timms, Cress & Co., Portland

Theo. F. Snyder, San Diego, Cal.



CENTRAL HIGH SCHOOL, MINNEAPOLIS, MINN.

Architect, William B. Ittner

Contractors, Pike & Cook Co.

Glazed by Forman, Ford & Co

Completely equipped with American Window Glass Co.'s Double Strength AA Quality First Choice of Leading Architects

Because of its absolute dependability, American Window Glass has been used in many fine buildings. Our care in inspection practically eliminates all imperfections and assures uniformity in thickness.

American Window Glass Co., General Office, Pittsburgh, Pa.

DOMESTIC SALES OFFICES
 New York, 220 Fifth Avenue
 Chicago, 1011 Peoples Gas Building
 Boston, Mass., 43 Tremont Street
 San Francisco, Cal., 862 Mission Street
 St. Louis, Mo., 1303 Syndicate Trust Building
 Memphis, Tenn., 440 North Main St.
 New Orleans, La., 904 Hennen Bldg.
 Atlanta, Ga., 1408 Candler Building

EXPORT SALES OFFICES
 Havana, Cuba, Apartado No. 930
 Buenos Aires, Argentina
 Mexico City, Mex., Apartado Postal No. 237
 Barranquilla, Colombia
 Bogota, Colombia
 Valparaiso, Chile
 Lima, Peru
 Toronto, Canada, 205 Continental Life Building



The above Trade-Mark appears on every light

Makes Garbage Burn Itself

The KERNER INCINERATOR

"Built-in-the-Chimney"

requires no coal, gas or any other fuel other than the dry waste deposited in the handy little hopper door. All you need do is to throw the garbage, waste paper, tincans, bottles and other refuse in the hopper door—and occasionally light the incinerator in the basement.

The dry waste burns readily and, in burning dries the wet waste so it also becomes fuel. Bottles and tin cans are dried, sterilized and later dropped into the ash pit.

SANITARY—ECONOMICAL—CONVENIENT—ODORLESS

Kerner Incinerator Co.

77 O'Farrell St. Factory, 38 Stanford St.

San Francisco

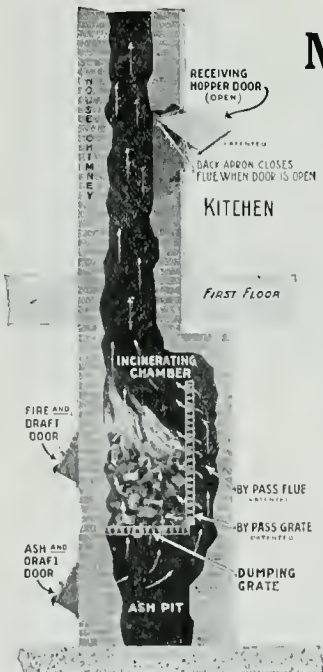

Patented Aug. 25, 1914; May 18, 1919



TRADE MARK

SIMPLEX BURNERS

For High or Low Pressure Boilers, Water Heaters, Kiln Dryers, Furnaces, Etc. Operated by Fractional H. P. Meters. Guaranteed for Efficiency and Durability.

BUNTING IRON WORKS

Factory BERKELEY

1215 FIRST NATIONAL BANK BLDG.
SAN FRANCISCO Phone Sutter 3225

Member of the Oil Burners Manufacturers' Association of California.

Fess System Turbine Fuel Oil Burner

The latest word in the science of burning fuel oil in an efficient and economical method

Ask for Bulletin No. 20

FESS SYSTEM CO., Inc.

1310 S. HILL ST.,
LOS ANGELES

218-220 Natoma Street, San Francisco

HOUSTON,
TEXAS

Member of the Oil Burners Manufacturers' Association of California.

OIL BURNER EQUIPMENTS

Low Pressure Air and Rotary Mechanical Atomizing Types

Refrigerating and Ice-Making Machines

Direct Expansion and Brine Circulating Systems

T. P. JARVIS MANUFACTURING CO.

CONTRACTING ENGINEERS AND MANUFACTURERS

275 Connecticut Street, San Francisco

Phone Market 3397

Member of the Oil Burners Manufacturers' Association of California.

JOHNSON'S ROTARY CRUDE OIL BURNER

Can be installed in any BOILER or FURNACE

Gives Satisfactory Results. Simple to Operate—
Automatic—Safe. Let us tell you more about this
Oil Burner.

S. T. JOHNSON CO.

1337 Mission Street - San Francisco, Cal.

Ask for Bulletin No. 28

Phone Market 2759

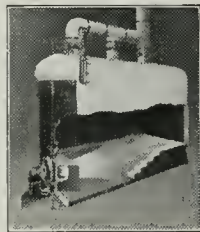

BURNER IN OPERATION

Agencies: SEATTLE LOS ANGELES FRESNO SAN DIEGO SACRAMENTO

Member of the Oil Burners Manufacturers' Association of California



Pump Governors
 Oil Burner Governors
 Reducing Valves
 Safety Valves
 Oil Valves
 Blowoff Valves
 Boiler Feed Water
 Regulators

Oil Pumping Sets
 Little Giant Improved
 Oil Burners
 Duplex Oil Pumps
 Rotary Oil Pumps
 Oil Heaters
 Draft Gauges
 Boiler Feed Pumps

G. E. WITT CO., Inc.

ENGINEERS

Manufacturers and Distributors

862-864 HOWARD ST.

Phone Douglas 4404

SAN FRANCISCO, CAL.

MEDUSA

WHITE CEMENT

THERE is no other water-
 proofing "Just as good" as
 "MEDUSA"

The "Original" waterproofing under which other pastes and
 powders are licensed.

PACIFIC MATERIALS CO.
 525 MARKET STREET, SAN FRANCISCO

A. F. Edwards, Pres.
 J. M. Fabbri, Vice-Pres.
 J. A. Mackenzie, Secy.

Office Telephone:
 MARKET 5070

Chas. F. Eisele, Asst. Mgr.
 J. Rubiolo, Asst. Mgr.
 D. A. Batsford, Asst. Mgr.

AMERICAN MARBLE & MOSAIC CO.

25-59 Columbia Square, San Francisco, Calif.
 Near Folsom St., Bet. 6th and 7th Sts.

Factory on Waterfront, South San Francisco. Phone South San Francisco 161

Fenestra

SOLID STEEL WINDOWS

DETROIT STEEL PRODUCTS CO., Detroit

Direct Factory Branch, 68 Post Street, San Francisco

Phone Sutter 1250



THE ARCHITECT AND ENGINEER

CONTENTS FOR JUNE, 1921

	PAGE
SPOKANE COUNTY COURT HOUSE, SPOKANE, WASHINGTON	Frontispiece
THE MOST NOTABLE ARCHITECTURE AND LAND- SCAPE ARCHITECTURE IN SPOKANE, WASHINGTON	48
<i>Frederick Hamilton</i>	
NEW STATE HOUSING ACT FOR CALIFORNIA	95
AMERICAN ARCHITECTURE THROUGH ENGLISH EYES	98
WOOD USED IN THE MANUFACTURE OF VENEERS	101
EDITORIAL	102-106
AMONG THE ARCHITECTS	107-112
WITH THE ENGINEERS	113-117
THE CONTRACTOR	118-123

PUBLISHED MONTHLY BY

THE ARCHITECT AND ENGINEER, INC.
626 - 27 FOXCROFT BUILDING, SAN FRANCISCO

W. J. L. KIERULFF
President

FREDERICK W. JONES
Vice-President

L. B. PENHORWOOD
Secretary

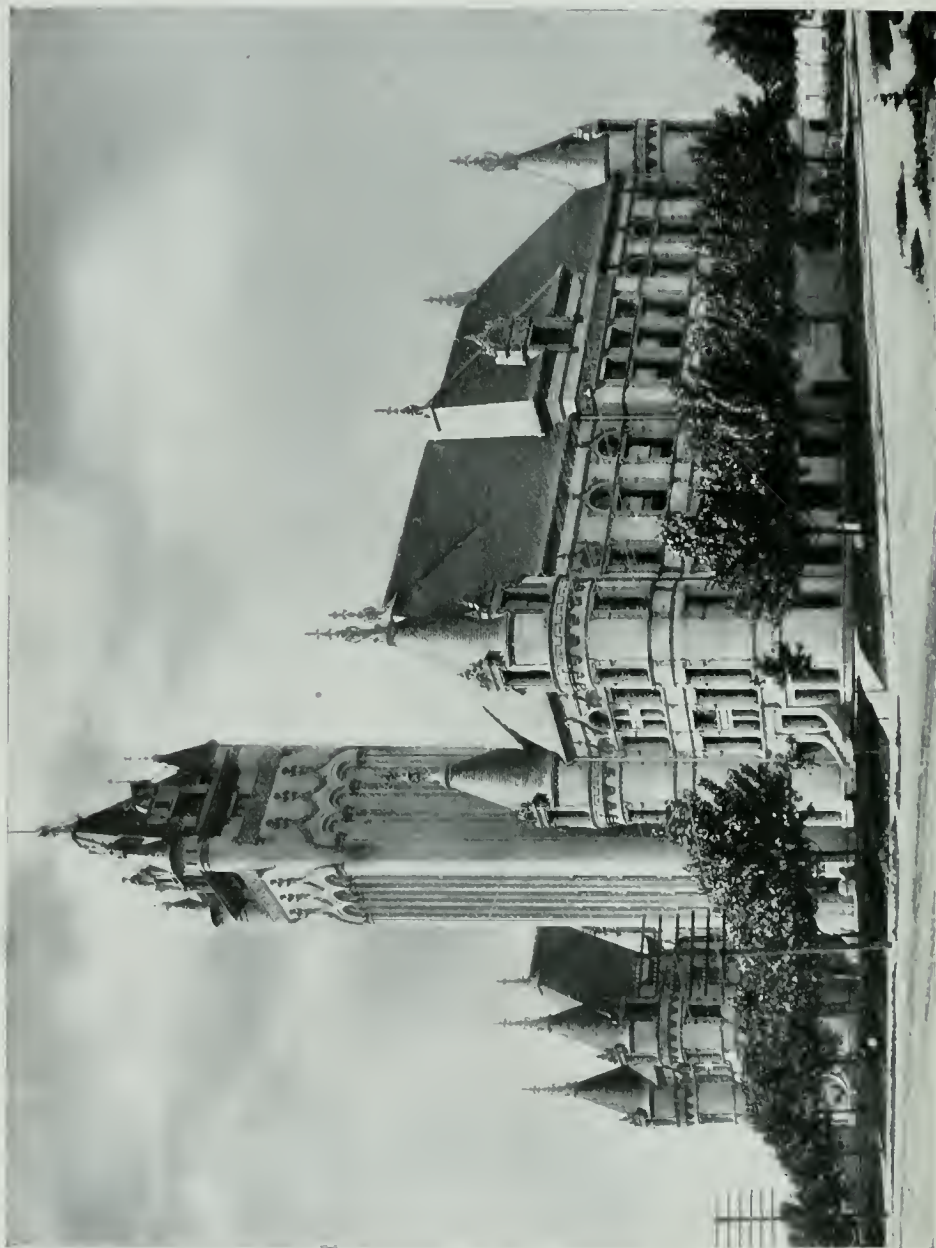

SPOKANE COUNTY COURT HOUSE, SPOKANE, WASH.

Awarded honorable mention as a notable example of Architecture

THE ARCHITECT AND ENGINEER

JUNE
1921



Vol. LXV
No. 3

The Most Notable Architecture and Landscape Architecture of Spokane, Washington

By FREDERICK JENNINGS

Spokane is the third city on the Pacific Coast to have selection made of its most notable examples of architecture, landscape architecture, and small houses, by a competent jury of architects, named by vote of the resident architects of that city as men whose judgment they would respect. Portland, in 1919, and Los Angeles, in 1920, had had similar juries report upon the most notable buildings and gardens in those cities, the results of these selections having been published in *The Architect and Engineer* for March, 1919, and August, 1920. It is evident from the photographs reproduced in this number that Spokane's buildings and gardens measure up very well with the standards set in Portland and Los Angeles, and yet with a character of design that is very distinctive from that shown by the typical buildings of the other two cities.

When we consider that Spokane is an inland city of only 100,000 population, while Portland has nearly three times as many people and there are ten times that many in Los Angeles county, it is distinctly to the credit of the smaller city that so many fine things have been produced. Why haven't the larger cities given more in proportion? But this is an article about Spokane and the recent findings of its architectural jury, and not about the failings of any city.

While it is not reported whether the jury agrees with Mr. Irwin Cobb's dictum, in the *Saturday Evening Post*, that Spokane has the finest hotel, bar none, in the West, they could not help but place it in the first ten of the notable examples of architecture in the city. It is hardly true, as some people have said about Spokane, that the city is built around a hotel, but it is certain that the unusual ability, judgment, and good taste of a man such as Mr. L. M. Davenport have made a tremendous impress of lasting benefit to this



One of the ten most notable examples of Architecture in Spokane as selected by the recent Jury.

DAVENPORT HOTEL, SPOKANE, WASH.
CUTTER & MALMGREN, ARCHITECTS





LOBBY, DAVENPORT HOTEL, SPOKANE, WASH.
Cutter & Malmgren, Architects

community, which, combined with the rare architectural force and genius for design of Mr. Kirtland Cutter, have produced architectural monuments of importance. For many years the strength and yet exquisitely finished character of Mr. Cutter's work has been well known throughout the northwest at least. The examples of his work selected by the jury will be interesting to all who see them in these pages.

It is also fine to see the high character of work of the younger generation of architects in Spokane, a number of whose buildings were premiated by the jury. This indicates the advance of architecture and increase in the better standards of design and utility which have been so marked all over the country through the past few years.

The report of the Spokane jury is given in full below, together with photographs of the principal buildings and gardens named.

The Jury's Report on the Most Notable Examples of Architecture and Landscape Architecture in Spokane

TO the President of the City Planning Commission, Spokane, Washington:

The jury appointed by you, on nomination of the architects of Spokane, for the purpose of selecting, in its opinion, the ten most notable examples of architecture, the three most notable examples of landscape architecture, the two most notable examples of public sculpture, and the five most notable small houses, to be found within ten miles of the County Court House, met for three successive days, on October 6, 7, and 8. To-

gether they visited all sections of Spokane and vicinity and noted with care all buildings, parks, gardens, and sculpture that seemed worthy of consideration.

The jury's instructions were that "points of architecture to be considered are usefulness, arrangement, relation of exterior design to interior design, beauty, harmony of detail, setting, purpose, color, and appropriateness." The size or cost of a structure did not unduly influence its decisions. It is to be regretted that people generally are often misled, on account of mere massiveness or the cost of a building or garden, into thinking of it as important example of design.

There is also a special quality possessed by some buildings and gardens, appealing to both trained architects and laymen—the elusive quality of charm—which is not easily definable, but which might be said to represent the soul of the building. They may embody this quality even when open to criticism in matters of detail. All kinds and uses of buildings—residential, commercial, industrial, educational, religious, public, and semi-public—were compared by the jury to determine which seemed to express the highest development of architecture. The final selections and lists are made up from those found most notable in the opinion of the jury regardless of size, types, or use.

The fact that stood out prominently to the jury in Spokane was that while a few fine buildings were evidently designed and superintended by trained architects, and set a standard which is cause for national comment and much local pride, many of the commercial buildings, particularly in the center of the city, seem to have been put up without the help of any competent architects at all, and hence are not alone structures of questionable utility, but also make a bad impression on visitors and public alike.

There is undoubtedly much to be proud of in Spokane. Many of the buildings, parks and gardens selected by the jury would be notable for their high merits in comparison with the best of any city in the country. It seems to us, however, that the city authorities should find a way to make it more worth while, particularly on the down town streets, for property owners to put up structures that will make a better appearance. It is not the intelligent group of property owners who naturally seek competent help to be sure of obtaining a permanent and satisfactory result in their building who need to be appealed to, but rather those who have had little opportunity to weigh and understand the value of good design. Whether it be by the remission of a small percentage of taxes to those who will design their buildings on a standard approved by the city, as in Paris, or by some other compensatory method, is not for this jury to suggest, but we believe and recommend that the City Planning Commission and Chamber of Commerce should take up this important matter, and find a solution. We feel sure that owners will cooperate with the city to provide uniformly better design, but the way to get them to do so on any worth while scale, lies in seeing that they feel compensated in so doing.

The Jury much regretted not to be able to discover any public sculpture in Spokane which is deemed worthy of honorable mention when judged by the high standard set by our foremost American sculptors.



DETAIL OF CEILING IN LOBBY



FIREPLACE IN THE LOBBY, DAVENPORT HOTEL, SPOKANE, WASH.
Cutter & Malmgren, Architects

One of the ten most notable examples
of Architecture in Spokane as selected
by the recent Jury.

The Ten Most Notable Examples of Architecture in Spokane

In the unanimous opinion of your jury the ten most notable examples of architecture in Spokane are as follows (the order is alphabetical, no precedence having been awarded):

Davenport Hotel.
 Elks' Temple.
 J. P. Graves Residence.
 Hutton Settlement.
 Monroe Street Bridge.
 Old National Bank Building
 R. B. Porter Residence.
 Washington Water Power Company Sub Station.
 Western Union Life Building.
 J. R. Wilson Residence.

Some of the outstanding points of each of these selections have been briefly noted by the jury as follows:

Davenport Hotel

The real and unusual charm of the hotel is its interior. In point of design and color there are few if any finer lobbies in America, in the intimate and domestic quality of its decorations and furnishings.

The livable atmosphere of the lobby extends throughout the hotel.

The detail of the Isabella dining room is crisp and sparkling, and the motives playful in character.

The lighting fixtures throughout are exceptionally well designed and placed.

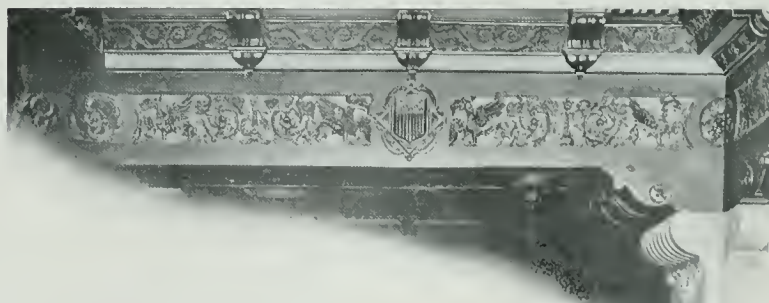

CEILING DETAIL ON MEZZANINE FLOOR,
 DAVENPORT HOTEL, SPOKANE, WASH.



BALCONY OF LOBBY



ELIZABETHAN ROOMS THROWN TOGETHER, DAVENPORT HOTEL.
SPOKANE, WASH.
Cutter & Malmgren, Architects



DETAIL IN BALLROOM



THE BALLROOM, DAVENPORT HOTEL.



DETAILS OF BALLROOM

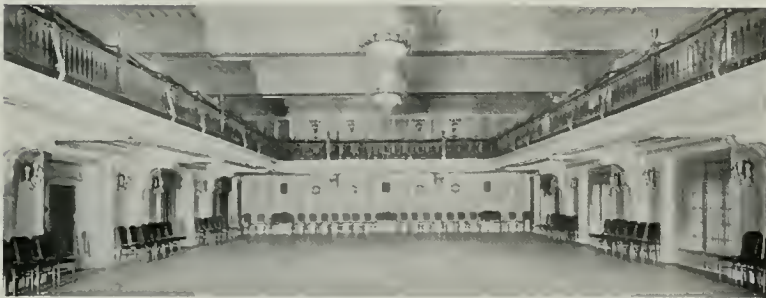

THE BALLROOM, DAVENPORT HOTEL, SPOKANE, WASH.
Cutter & Malmgren, Architects

One of the ten most notable examples
of Architecture in Spokane as selected
by the recent Jury.



THE ISABELLA DINING ROOM



A CORNER OF THE DINING ROOM,
HOTEL DAVENPORT, SPOKANE, WASH.
Cutter & Malmgren, Architects

One of the ten most notable examples
of Architecture in Spokane as selected
by the recent Jury.



GUEST ROOM, DAVENPORT HOTEL, SPOKANE, WASH.
Cutter & Malmgren, Architects



POMPEIAN BARBER SHOP IN THE BASEMENT
DAVENPORT HOTEL



ELKS' CLUB, SPOKANE, WASH.
E. J. BAUME ARCHITECT

One of the ten most notable examples
of Architecture in Spokane as selected
by the recent Jury.



MAIN LOBBY, ELKS' CLUB, SPOKANE, WASH.

Elks' Temple

At the time of the judgment, the interior was not completed, so the jury passed on the merits of the exterior alone.

This is an Italian Renaissance motif very delightfully interpreted in materials, composition and details. While sufficiently dignified and formal for a city club, it has good domestic quality. The loggia treatment of the second story is especially happy, though one longs for rich color in its ceiling.

From the balcony in the rear a fine view of Spokane falls is obtained through the arches of the Monroe street bridge.

J. P. Graves Residence

A large residence of the English manor house type, in brick and stucco. Terraces, garden houses, fountains, lawn and shrubbery combine to give the immediate environment worthy of its character, although the entrance to the property and the drive to the house might be much improved by a different landscape treatment.

More attractively designed than the exterior, the interior is well planned, making the most of numerous lovely vistas of garden and valley. The spacious living hall is beautifully treated in dark oak, with well designed stairway, mantels, etc., and has a fine ornamental plaster ceiling.



RESIDENCE OF J. P. GRAVES, SPOKANE,
WASH. KIRTLAND CUTTER, ARCHITECT

One of the ten most notable examples of Architecture in Spokane as selected by the recent Jury.

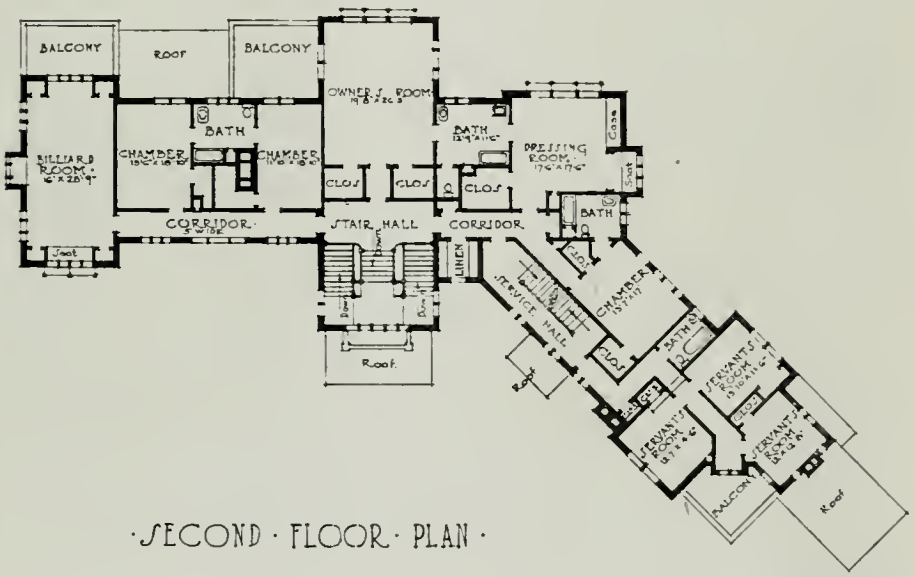
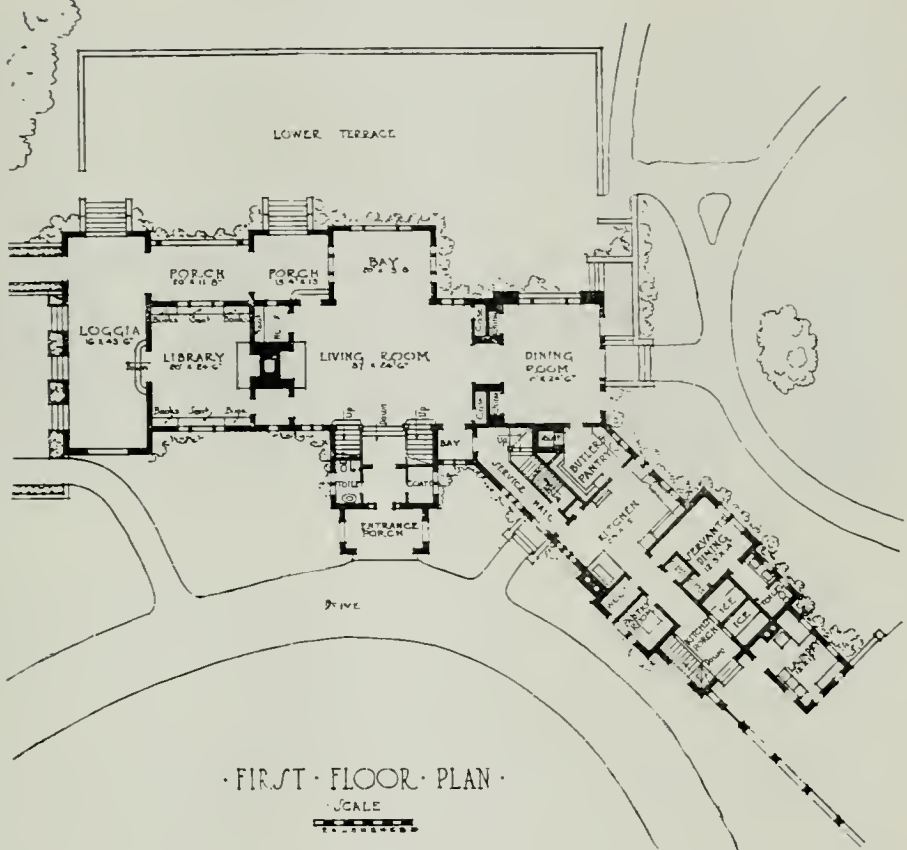

PLANS OF RESIDENCE OF J. P. GRAVES, SPOKANE, WASH.
KIRTLAND CUTLER, ARCHITECT

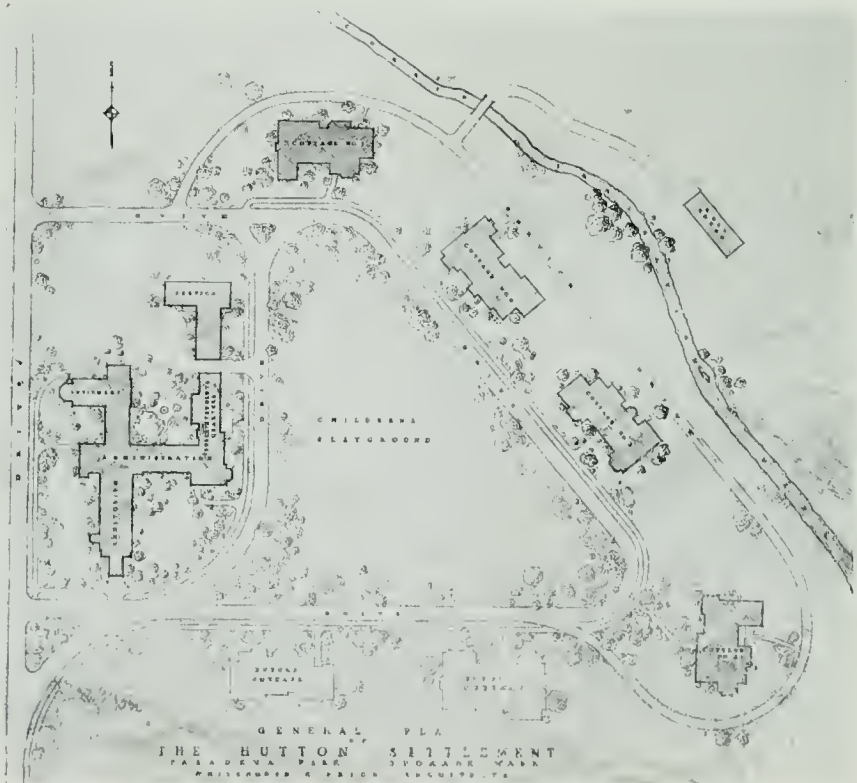

ADMINISTRATION BUILDING, HUTTON SETTLEMENT

GENERAL PLAN, THE HUTTON SETTLEMENT, PASADENA PARK, SPOKANE, WASH.
Whitcomb & Price, Architects

One of the ten most notable examples of Architecture in Spokane as selected by the recent Jury.

Hutton Settlement

An interesting group of well designed buildings in the English Tudor style. Although the lack as yet of a proper landscape planting scheme detracts from the charm of the group, doubtless this will be remedied in the future.

The administration building is especially attractive in composition, and the whole group is really domestic in character, as befits an orphans' home, a point often lost sight of in institutional buildings of a similar character.



COTTAGE NO. 3, HUTTON SETTLEMENT



COTTAGE NO. 1, HUTTON SETTLEMENT



COTTAGE NO. 2, HUTTON SETTLEMENT



OFFICE AND TOWER, THE ADMINISTRATIVE
BLDG., HUTTON SETTLEMENT, SPOKANE, WAS
WHITEHOUSE & PRICE, ARCHITECTS

One of the ten most notable examples
of Architecture in Spokane as selected
by the recent Jury.



MONROE STREET BRIDGE, SPOKANE, WASH.
J. C. Ralston, Engineer; Kirtland Cutter, Architect

One of the ten most notable examples of Architecture in Spokane as selected by the recent Jury.

Monroe Street Bridge

A concrete arched bridge, boldly and effectively designed, but unfortunately marred by the juxtaposition of a later railroad bridge which crosses over it. The details of its towers, piers and balustrade are in good scale, and its proportions excellent. The central arch frames a beautiful picture of Spokane falls from below.

In the cascades, rocky shores and islands of the river, Spokane has an asset which might be developed into a civic feature of unique attractiveness, if properly landscaped. Now it is hardly that.

Old National Bank

An attractive office building in Renaissance style, executed in terra cotta, which is consistently designed. The alley and side walls are laid out with the idea that they are quite as visible as the street facades, a point often overlooked in otherwise excellently designed buildings.

The building would be improved by painting the window frames and the iron work of the first story a lighter shade of green. The dark granite base cuts down the apparent height of the first story in a manner to be deprecated. The composition of the first story entrance front, with its two similar entrance motives and bad spacing of piers is hardly a happy solution of the problem.



OLD NATIONAL BANK BLDG., SPOKANE, WASH.
D. H. BURNHAM & CO., ARCHITECTS

One of the ten most notable examples
of Architecture in Spokane as selected
by the recent Jury.



R. B. PORTER RESIDENCE (FORMERLY DAVENPORT RESIDENCE),
SPOKANE, WASH. CUTTER & MALMGREN, ARCHITECTS

One of the ten most notable examples
of Architecture in Spokane as selected
by the recent Jury.

The Porter Residence

A remarkably attractive house of distinctly domestic character, yet with a bigness and boldness of treatment that is very pleasing. Every advantage has been taken of a splendid hillside site and the terraces and large grounds have had landscape treatments that makes this also one of the finest examples of landscape architecture in Spokane. The great care with which every stone has been selected to take an harmonious and fitting part in the whole ensemble reflects the guiding spirit of an artist of no usual calibre.



ENTRANCE FACADE, R. B. PORTER RESIDENCE, SPOKANE,
WASH. CUTTER & MALMGREN, ARCHITECTS



FRONT GARDEN WALK, R. B. PORTER RESIDENCE, SPOKANE,
WASH. CUTTER & MALMGREN, ARCHITECTS

One of the ten most notable examples
of Architecture in Spokane as selected
by the recent Jury.



LOWER TERRACE. SHOWING WINDOWS TO SWIMMING POOL UNDER UPPER TERRACE,
RESIDENCE OF MR. R. B. PORTER, SPOKANE, WASH.
Cutter & Malmgren, Architects

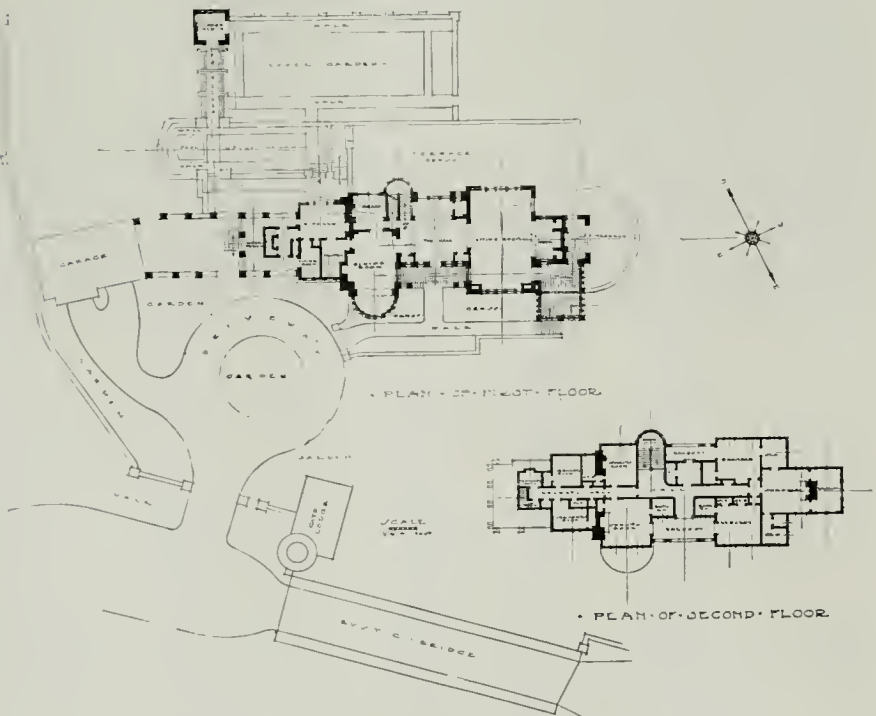

PLAN OF THE R. B. PORTER RESIDENCE



INGLENOOK IN THE DINING ROOM, RESIDENCE OF R. B. PORTER,
SPOKANE, WASH.

Cutter & Malmgren, Architects

One of the ten most notable examples
of Architecture in Spokane as selected
by the recent Jury.

Water Power Sub Station

A utilitarian building in brick, whose design expresses its purposes successfully. It is bold in mass, with well spaced fenestration, and an imposing cornice treatment in brick.



WASHINGTON WATER POWER COMPANY'S SUBSTATION, SPOKANE, WASH.
Cutter & Malmgren, Architects

One of the ten most notable examples
of Architecture in Spokane as selected
by the recent Jury.



WESTERN UNION LIFE INSURANCE CO. BLDG., SPOKANE, WASH.
Cutter & Malmgren, Architects

One of the ten most notable examples of Architecture in Spokane as selected by the recent Jury.

Western Union Life Building

A distinctly novel idea for a business office, one worthy of emulation. Set in a quaint garden of flowers and shrubs, which is separated from the street by a wall of very interesting brick work, this Georgian building has a most charming and restful environment. The brick work is unusually attractive in texture and color. The color of the roof makes an excellent foil for the well designed dormers, gables and chimneys. The gates are of wrought iron, well executed.

The only jarring note is the tall advertising sign of the company, which is quite out of place in such a setting. It should be replaced by one more in keeping with its environment.



ENTRANCE DOORWAY, WESTERN UNION LIFE
INSURANCE CO. BUILDING, SPOKANE, WASH.
CUTTER & MALMGREN, ARCHITECTS

One of the ten most notable examples
of Architecture in Spokane as selected
by the recent Jury.



FIREPLACE IN LOBBY, WESTERN UNION LIFE
INSURANCE CO. BUILDING, SPOKANE, WASH.
CUTLER & MALMGREN, ARCHITECTS

One of the ten most notable examples
of Architecture in Spokane as selected
by the recent Jury.

Wilson Residence

An attractive colonial house of moderate size, successfully executed. Pleasing in mass, the detail is refined, and has the charm of the best work of this period. The mantels, china cabinets, and other interior details are very well designed. An unusual feature for a house of this size is the central staircase, with double returns from the landing. This is successfully handled, and in scale with the rest of the interior.



J. R. WILSON RESIDENCE, SPOKANE, WASH.
Whitehouse & Price, Architects

One of the ten most notable examples
of Architecture in Spokane as selected
by the recent Jury.

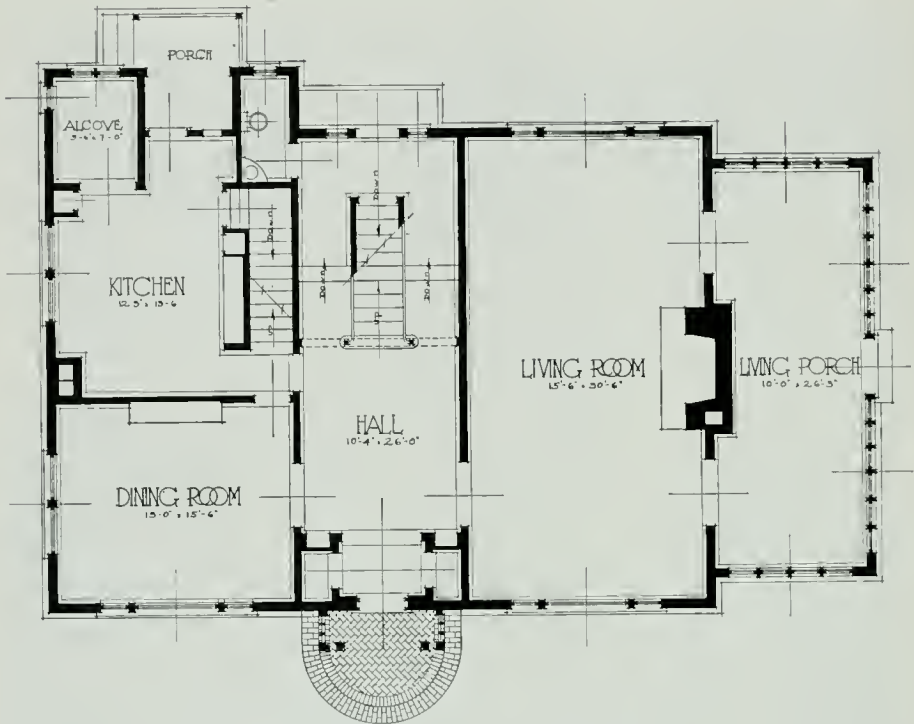

• FIRST • FLOOR • PLAN •

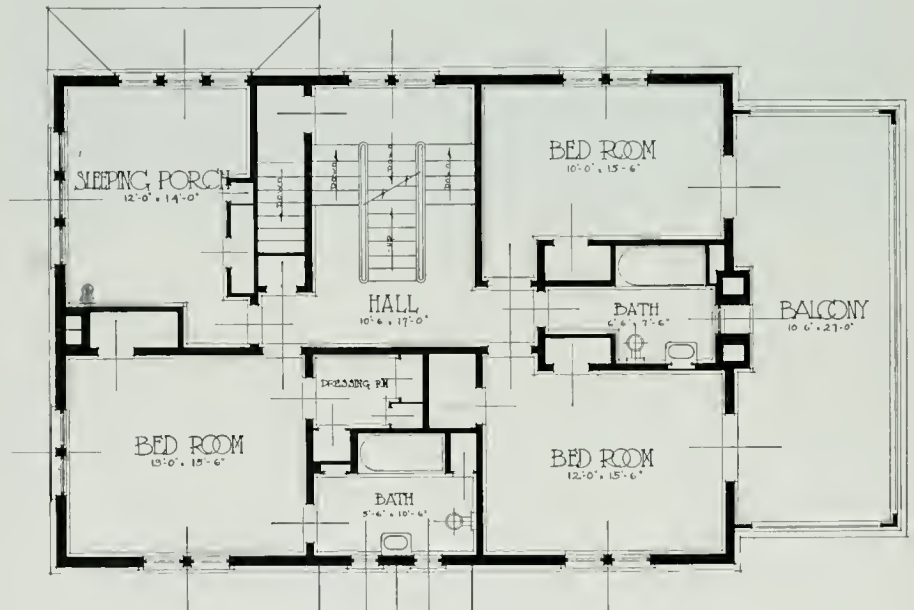

• SECOND • FLOOR • PLAN •

PLANS, J. R. WILSON RESIDENCE, SPOKANE,
 WASH. WHITEHOUSE & PRICE, ARCHITECTS



MAIN ENTRANCE DOORWAY, J. R. WILSON RESIDENCE,
SPOKANE, WASH. WHITEHOUSE & PRICE, ARCHITECTS

One of the ten most notable examples
of Architecture in Spokane as selected
by the recent Jury.



HALL, INTERIOR OF J. R. WILSON RESIDENCE, SPOKANE, WASH.
Whitehouse & Price, Architects

The Three Most Notable Examples of Landscape Architecture in Spokane

In the unanimous opinion of the jury the three most notable examples of landscape architecture in Spokane are as follows, alphabetically arranged:

J. P. Graves Grounds
Manito Park
R. B. Porter Grounds

Some of the gardens in Spokane are unusually interesting and well laid out, but undoubtedly the most attractive landscape work in the city has been done for the Park Board.

The jury cannot too highly commend the breadth of vision, energy, and results obtained by Mr. A. L. White, president of the Park Board, who more than ten years ago secured a comprehensive park and boulevard park system plan from America's foremost landscape architects, Olmsted Brothers of Boston, and since that time has secured gifts to the city of more than 32 miles of boulevards, which will link up that plan and give Spokane one of the finest boulevard and park systems in the country.

The Five Most Notable Small Houses in Spokane

In the unanimous opinion of the jury the following five small houses are found to be the most notable of those seen by the jury, alphabetically arranged:

Condon Residence
 R. H. Goodhue Residence
 Ernest V. Price Residence
 Dr. Charles F. Rigg Residence
 C. A. Weiss Residence

Honorable Mention for Other Notable Examples of Architecture and Landscape Architecture in Spokane

While the previous named selections represent, in the opinion of your jury, the most notable examples of architecture, landscape architecture, and small houses in the city, there are a considerable number of others very worthy of consideration, and they have been awarded honorable mention, as follows:

Honorable mention as a notable example of architecture in Spokane was awarded the following:

County Court House
 K. K. Cutter Residence
 F. J. Finucane Residence
 Dr. S. B. Hopkins Residence
 T. J. Humbird Residence
 Hangman Creek Bridge
 E. A. Lindsley Residence
 Pantages Theater
 Postoffice Building
 St. Augustine's Church and School
 St. James Episcopal Church
 Sperry Mill
 Store Building

Honorable mentions given for landscape architecture were as follows:

T. J. Humbird Grounds
 E. A. Lindsley Grounds
 Rockwood Boulevard
 A. L. White Grounds

In conclusion, Spokane is fortunate in being able to present to the world such splendid examples of architecture and landscape architecture as have been selected by the jury. Properly displayed and brought to the attention of others, they are bound to provoke favorable and complimentary impressions and comment for Spokane. That the most may be made of the city's opportunities the following suggestions are made by the jury:

1. To the Chamber of Commerce—That while this jury knows it is not infallible and that there may be differences of opinion as to the selections here made, we are unanimous in the recommendation that the chamber use exclusively in its publicity, reproductions of the buildings or gardens here selected in order to show what a high standard Spokane has developed—one that compares favorably with the best in the country—and not try to substitute other buildings unless selected by a similarly competent and disinterested jury.



CONDON RESIDENCE AS REMODELLED, SPOKANE,
ALBERT HELD, ARCHITECT
WASH.

One of the five most notable examples of small house architecture in Spokane as selected by the recent Jury.



R. A. GOODHUE RESIDENCE, SPOKANE, WASH.
Morrison & Stimson, Architects

One of the five most notable examples of small house Architecture in Spokane as selected by the recent Jury.

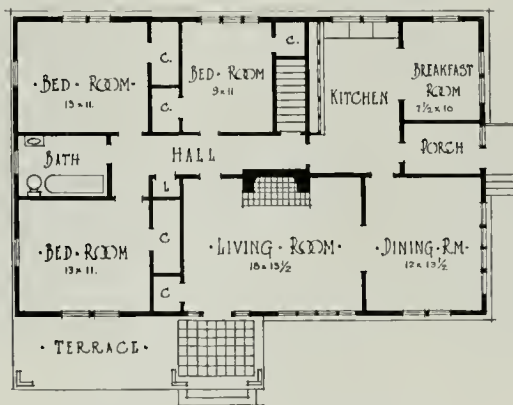

PLAN, R. A. GOODHUE RESIDENCE



RESIDENCE OF E. V. PRICE, SPOKANE, WASH.
Whitehouse & Price, Architects

One of the five most notable examples
of small house Architecture in Spokane
as selected by the recent Jury.

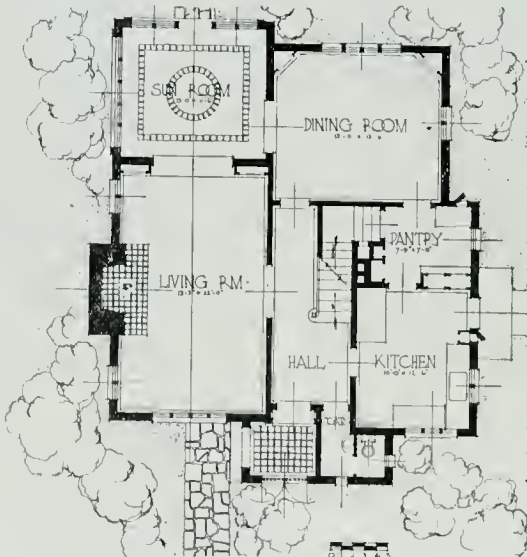

PLAN, E. V. PRICE RESIDENCE



C. A. WEISS RESIDENCE, SPOKANE
Keith & Whitehouse, Architects

One of the five most notable examples
of small house Architecture in Spokane
as selected by the recent Jury.



LATAH CREEK BRIDGE, SPOKANE, WASH.
Martin McCartney, City Engineer

Awarded honorable mention as
a notable example of Architecture
in Spokane by the recent Jury.



CUTTER RESIDENCE, SPOKANE
K. K. CUTTER, ARCHITECT



Awarded honorable mention as a notable example of Architecture in Spokane by the recent jury.

GARDEN FACADE, CUTTER RESIDENCE, SPOKANE. K. K. CUTTER, ARCHITECT



ANOTHER VIEW OF SOUTH FACADE, CUTLER RESIDENCE, SPOKANE



ENTRANCE DOORWAY, CUTLER RESIDENCE, SPOKANE
K. K. Cutter, Architect

Awarded honorable mention as
a notable example of Architecture
in Spokane by the recent Jury.



DETAIL OF FRONT DOOR, CUTTER RESIDENCE,
SPOKANE. K. K. CUTTER, ARCHITECT

Awarded honorable mention as
a notable example of Architecture
at Spokane by the recent Jury.



FIREPLACE IN DEN, CUTTER RESIDENCE, SPOKANE,
WASH. K. K. CUTTER, ARCHITECT

Awarded honorable mention as
a notable example of Architecture
in Spokane by the recent Jury.



DINING ROOM, CUTTER RESIDENCE, SPOKANE
K. K. Cutter, Architect

2. To the City Council—That the city secure, by lease or otherwise, the property surrounding Spokane falls, and plant and park it as soon as possible. This would transform one of the greatest potential scenic assets of the city from a condition now unsightly and greatly disappointing to visitors, into one of note to tourists from all parts of the world.

3. To the City Planning Commission—That the commission persevere in securing for Spokane a zoning ordinance, a major traffic street plan, and civic-center for the grouping of public buildings. The need and advantage of such planning in Spokane is apparent to the most casual student of civic growth.

In conclusion, we desire to express our heartiest compliments to the people of the city for the fine things that we have found, and our thanks to those responsible for bringing us here, for the cordial way in which matters were laid before us.

Respectfully submitted,

CARL F. GOULD, A. I. A.,
ALBERT E. DOYLE, A. I. A.,
ARTHUR LOVELESS, A. I. A.,
GEORGE W. FULLER,
CHARLES H. CHENEY, A. I. A.



Awarded honorable mention as a notable example of Architecture in Spokane by the recent Jury.

DR. S. B. HOPKINS RESIDENCE, SPOKANE
MORRISON & STIMSON, ARCHITECTS

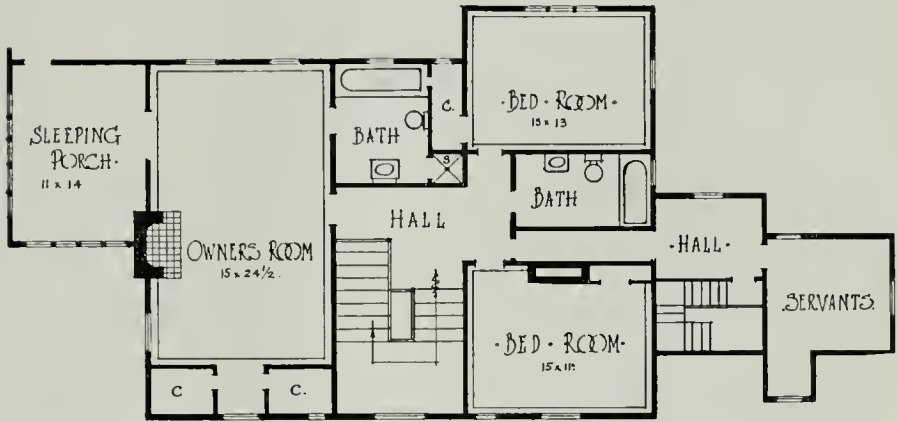

• SECOND FLOOR •

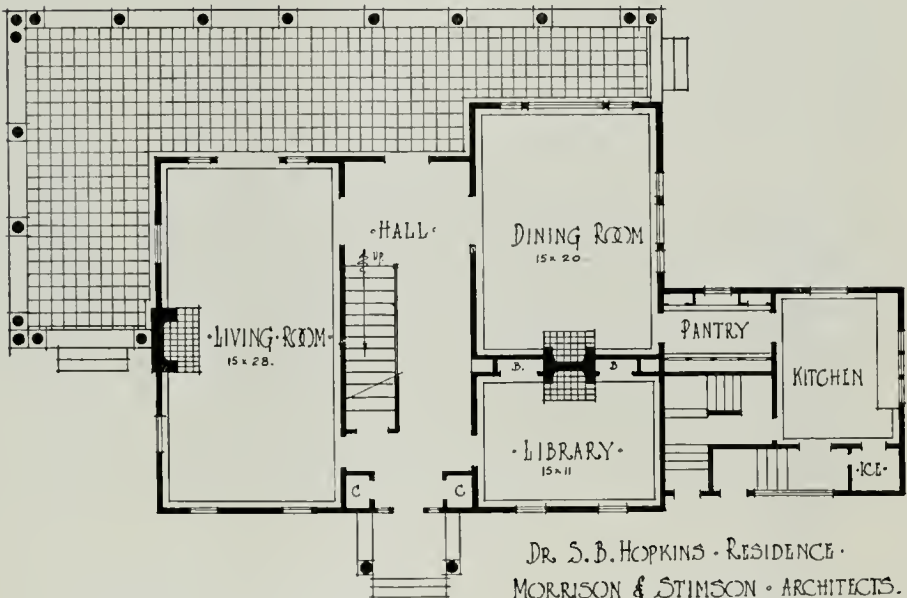

• FIRST FLOOR PLAN •

DR. S. B. HOPKINS • RESIDENCE •
MORRISON & STIMSON • ARCHITECTS •
• SPOKANE •



RESIDENCE OF E. A. LINDSLEY, SPOKANE
H. E. Smith, Architect

Awarded honorable mention as
a notable example of Architecture
in Spokane by the recent Jury.



ST. JAMES EPISCOPAL CHURCH, SPOKANE
Whitthouse & Price, Architects

Awarded honorable mention as
a notable example of Architecture
in Spokane by the recent Jury.

The New State Housing Act for California

THE new state housing act, revising and modifying the tenement house, hotel and dwelling laws, will go into effect September 1, 1921. Changes have been made largely, if not almost wholly with a view to making building of tenement houses and hotels easier for and more attractive to the owner. To what extent building will be aided cannot be determined until the new law shall become operative. If the assurances of those who have been most active in securing the revision are fulfilled, building of tenement houses and hotels will be greatly stimulated; indeed there should be a great building boom next fall.

While the new act shows much care in the preparation of the text a careful study of its provisions discloses ambiguities in some particulars and a few provisions at variance or in conflict. It is not surprising this should be so as the codification of the three existing laws is a difficult task. Authorities charged with the enforcement of the new act will undoubtedly be called upon to make interpretations of many features of its provisions in addition to fixing certain policies which are left to their discretion.

Tenement Houses and Hotels—Under the new act a tenement house is defined to be any house or building, or portion thereof, more than 1-story in height, which is "occupied as the home or residence of three or more families living independently of each other and doing their cooking in the said building." This eliminates "flat buildings" as recognized by the existing law.

A hotel is defined as any house or building more than 1-story in height, or portion thereof, containing 6 or more guest rooms, or which are occupied by 6 or more guests and "shall include hotels, lodging and rooming houses, Turkish baths, bachelor hotels, studio hotels, public and private clubs and any such building of any nature whatsoever so occupied, except jails, hospitals, asylums, sanitoriums, orphanages, prisons, detention buildings and similar buildings where human beings are housed and detained under restraint." The latter part of this definition noting exceptions, differs from the text of the existing law, which is quite clear. The application of the phrase "where human beings are housed and detained under restraint" is ambiguous. Apparently it admits of two classifications of hospitals, sanitoriums and orphanages, especially in view of the wording of the existing law.

A "building" is defined under the new act as "a tenement house, hotel or dwelling as the case may be, or a combination of any two or more such buildings." Inasmuch as there is no provision in the new act prohibiting "single rooms" in apartment houses it is inferred that such a combination is permitted. It is probable that where apartments and hotel rooms are combined, the law regulating construction of tenement houses will be applied rather than the law regulating hotels.

Height of Buildings—By far the greatest advantage under the new act accrues to fireproof hotels and tenement houses. All restrictions in the height of such buildings, limited by present laws to $1\frac{1}{2}$ times the width of the street, are removed. Semi-fireproof buildings are restricted to 6 stories as under present laws or twice the width, instead of $1\frac{1}{2}$ times the width of the street. Wooden buildings are limited to 3 stories for living purposes and a height of 36 ft. or twice the width of the street, but the height may be increased to 40 ft. providing courts are made the same as required for a 4-story building. If hotel or tenement house is on sloping ground no point shall be more than 50 ft. above the adjoining ground level. Los Angeles city building ordinance limits Class A fireproof hotel and tenement buildings to 150 ft. Class B buildings to 5 stories. Class C buildings to 4 stories and wooden buildings to 3 stories. It should be noted that city ordinances supercede the state law when requirements of the former are more stringent.

Requirements for Courts—Provisions for courts in tenement houses are not greatly changed. In the new act the maximum length of outer courts for two-story buildings is fixed at "00" ft., which is apparently intended to remove any restriction as to length, the minimum width being fixed at 4 ft. For 8 stories or more the minimum width of outer courts is 12 ft. and maximum length 40 ft. No change is made in the provision for inner courts for tenement houses except where they are bounded by a lot line. The new law fixes the minimum width and minimum area only. This reduces the minimum area for 2-story buildings from 75 to 60 sq. ft. No change is made in requirements for 3-story buildings but court areas for 4-story buildings are increased from 150 to 175 sq. ft. and for 5-story buildings

reduced from 250 to 225 sq. ft. For 6 stories the minimum width is reduced from 16 to 12 ft. and minimum area from 400 to 360 sq. ft.; for 7 stories minimum width is reduced from 20 to 15 ft. and area from 625 to 525 ft. and for 8 stories and above minimum width is reduced from 24 to 18 ft. and area from 840 to 630 sq. ft.

Radical changes are made in requirements for courts in hotels. All restrictions on length of outer courts are removed. The minimum width under the new act ranges from 4 ft. for 2 stories to 14 ft. for 7 stories or more as compared with 4 to 14 ft. under the existing law. Inner courts for hotels are reduced by the new act from a minimum width of 6 ft. for 2 stories to 24 ft. for 8 stories or more to a minimum width of 5 ft. for 2 stories to 16 ft. for 8 stories or more. The minimum area required in existing law is replaced by fixing a minimum length, which reduces the minimum length for 2-story buildings from $12\frac{1}{2}$ to 9 ft. For inner courts bounded by lot line the new act fixes the minimum width at 4 ft. for 2 stories to 10 ft. for 8 stories or more; the minimum under the existing law being 5 ft. to 24 ft.

Intakes to Courts—No intakes are required by the new act for courts in hotels. Intakes in tenement houses must have minimum dimensions of 3 ft. x 6 ft. 6 in. regardless of area of court and if the intake is at the second floor line it may have a sectional area of only 10 sq. ft. as compared with $19\frac{1}{2}$ sq. ft. under the existing law.

Size of Rooms—The minimum size of living and sleeping rooms for tenement houses and hotels is fixed at 80 sq. ft. instead of 90 sq. ft. as now required and the minimum width may be 6 ft. instead of 7 ft. Requirement for kitchen 50 sq. ft., is not changed. Under the new act "sleeping porches and similar rooms" may have an area of only 70 sq. ft. provided they have windows on two sides or a window area twice the minimum size prescribed for rooms. The provision requiring at least one room in every apartment of not less than 120 sq. ft. area is unchanged. The minimum size of a toilet compartment is reduced from 3 ft. to 30 in. in width. Ceiling heights are fixed at 9 ft. except that in buildings where not more than 2 families are housed on the second floor, the second story ceiling may be 8 ft. 6 in. Ceiling heights of bath and toilet rooms and closets are not changed from 7 ft. 6 in.

No change is made in requirements for window areas. Windows from hallways and rooms may open through roofed porches that do not diminish the required area of yards and courts provided the windows face the street, yard or court. Under the existing law such a porch cannot be over 7 ft. in depth and the minimum area opposite the window is prescribed. These restrictions are removed by the new act.

Stairways and Corridors—Minimum width of stairways and corridors is reduced by the new act from 3 ft. 6 in. to 3 ft. (Los Angeles city ordinance requires 4 ft.) Under the existing law a minimum of two stairways is required for every building. The new act requires one for each 6000 sq. ft. floor space in fireproof buildings, 5000 sq. ft. in semi-fireproof and 4000 sq. ft. in wooden tenement houses or hotels, or fraction of such area. Offsets in corridors may be three times the width of the corridor in depth, instead of $1\frac{1}{2}$ times as now required. Where the present law requires two means of egress from each apartment in a semi-fireproof or wooden building the new law requires two "reasonable means of egress."

Fire Escapes—Under the existing law a fire escape is required for each 3000 sq. ft. floor space in tenement houses or hotels and an additional fire escape for each additional 4000 sq. ft. or fraction thereof. Under the new act one fire escape is required for each 6000 sq. ft. in fireproof buildings and 4000 sq. ft. in semi-fireproof and wooden buildings and one for each additional 5000 sq. ft. in all types of buildings.

Sanitary Provisions—Sanitary provisions in the existing law are changed only slightly in the new act. Under the latter toilet or bathroom walls may be painted with some non-absorbent material instead of being plastered and bases may be 2 in. instead of 6 in. Glazed cement pipe may also be used in sewers as well as cast iron and vitrified pipe. Vent shafts for hotels under the new act may have a minimum area of 12 sq. ft. instead of 16 sq. ft. and least dimension of 30 in. instead of 3 ft. No intakes are required. Vent shafts on lot lines for tenement houses may not be less than 2 ft. wide with an area of 16 sq. ft.

Building Construction—Specific requirements for construction not contained in the existing law are in the new act. Under the latter foundations for tenement houses and hotels must be not less than 16 in. wide at the bottom, 6 in. at top and 10 in. below ground. Present minimum requirements are 12 in. at base, 6 in. at top and 10 in. below ground. Not less than 2x4 in. studs may be used for walls and bearing partitions and if building is over 2 stories 2x6 in. studs are required for lower story. Fire stops at floor and ceiling lines and midway height of each story are required, this provision being similar to Los Angeles city ordinance. Walls must be braced every 25 ft. unless covered with metal lath weighing not less than 3.4 lbs. to sq. yd., and plastered and back plastered. The minimum size for joists at second floor and above is fixed at 2x8 in. with no span over 14 ft. Floor joists must be cross bridged with

2 in. pieces every 7 ft. Floors must be built to carry live load of 40 lbs. and roofs live load of 20 lbs. per sq. ft., loads to be computed on basis of factory of safety of 4, Kidder's and other standard handbooks being recognized as standards of practice for computations.

The new act omits the present requirement for plastering on metal lath or plaster board of walls and ceilings of rooms in semi-fireproof tenement houses and hotels not over 4 stories in height.

The new act requires that where "approved plasterboard" is used in lieu of metal lath on wall surfaces exposed to weather metal lath or wire mesh must be placed over the plasterboard. Concrete tile is allowed for facing courts in fireproof buildings in addition to terra cotta. (Los Angeles city ordinance does not permit concrete tile for this purpose.) All provisions in the existing law relating to rat-proof construction are eliminated in the new act, except for kitchens and rooms for storage of food in hotels.

There is nothing apparently in the new act to prohibit cooking and sleeping in the same room as provided in the present law.

Regulations for Dwellings

Regulations for construction of dwellings in the new state housing act will apply only to incorporated counties, cities and towns. Codified in connection with the hotel and tenement house laws they are somewhat scattered and involved, appearing in some instances under the definite heading "dwellings," and in other cases under general provisions for "buildings."

A dwelling is defined, taking note of all restrictions, as any building not over one-story in height designed to be used entirely or partly for living or sleeping purposes, or any building or portion thereof more than 1-story, designed or intended to be used as the home for not over 2 families, or which contains not over 5 guest rooms or sleeping rooms or both.

The new act requires a window court in front of all windows, at least 40 sq. ft. in area and not less than 4 ft. in its least dimension. Eaves or cornice may extend not over 8 in. unless the width of the window court is increased. Window courts are not required on streets or alleys 16 ft. or more in width. If two or more dwellings are on a lot each must be provided with a window court irrespective of the others. Where there is a rear yard 4 ft. wide behind any dwelling for entire width and window court on each side extends the entire length thereof to a public street or alley 16 ft. wide in front of the dwelling, the window courts may be only 3 ft. in width.

All living and sleeping rooms must have window area equal to at least one-eighth of floor area; except that in dwellings for one family with no guest rooms the window area need not exceed 12 sq. ft. irrespective of size, but cannot be less. Toilet and bathroom windows must be at least 3 sq. ft. area, and may open into a vent shaft. French doors and windows are allowed as window area. Windows may open through roofed porches provided they face on the open side of the porch and proper court area is provided. The restriction of 7 ft. on depth of porches in counting allowable window area, is removed.

The new act makes no requirements as to size of rooms or ceiling heights except that toilet and bathroom ceilings must be 7 ft. 6 in. in clear and toilet compartments at least 30 in. wide. Floor joists must be at least 6 in. above ground, but masonry floors may be laid on the ground. A toilet is required in every dwelling, one for each family, and connected with sewer or cesspool. Segregated outside toilets for men and women are allowed for certain number of families in a group of dwellings.

A feature of the new act is requirements for construction of dwellings. Roofs must be waterproof and every semi-fireproof or wooden building must have a roof covered with some approved fire resistant material. Floors must be constructed to carry a live load of 40 lbs. per sq. ft. and roofs live load of 20 lbs. per sq. ft., with a factor of safety of 4; Kidder's and other standard handbooks to be used as basis for computations.



PANEL IN DAVENPORT HOTEL, SPOKANE

American Architecture Through English Eyes

THE following article reprinted in part from the April number of Harper's Monthly Magazine gives a clear and concise recital of the impressions of a visitor from England to New York:

The colossal scale of New York naturally makes upon the stranger his first important impression. The American does not realize what a shock New York can be to a European who has never before seen a building higher than ten floors; the effect is bewildering. The monster hotel where the stranger makes his first acquaintance with America is itself a shock. I began in a hotel which seems to have two thousand bedrooms, and to carry a rent-roll of two thousand dollars a day. In other words, this is Brobdingnag, the land of the giants. Gigantic chaos, that is the first feeling I had in New York.

For New York is all the cities. It is the giant city grouped about its colossal forest of parallelepipeds of concrete and steel. One can't find one's way. The plan of the city is simple, but it is so large and hangs so heavily over you that you become dazed. You can't find the news stand in the marble lounge; the pages whom you sent on a message do not come back, but fade in the distance, grow old and die in a distant region, perchance to be buried under leaves. It is such a little thing, a page boy, in Brobdingnag! He is so much below scale! They brought me a telephone message the first day. It comprised twenty-two words and was written on a sheet of paper three feet four inches long. Here indeed is the toy of a giant. It is only little by little, as you grow used to this enormity, that you reach comfort in New York, that you look casually at the Equitable Building, and contemptuously at the little apartment houses of eight floors.

Standing by the building plot between Vanderbilt and Park avenues, and looking westward, you see a strange thing—an enormous office building against the back of what outlines itself the spire of a church. A big office and a little church; what a change since the Middle Ages! And the little New York church is vigorously, resolutely gothic. They nearly all are, in New York, as they are elsewhere. Even in Fifth avenue, vast erections of stone are fretted into trefoil and cinquefoil, garnished with finials and gargoyles, spired and flying buttressed, as if Chartres and Canterbury had crossed the ocean. It is tragic. Nothing is more beautiful than the American grain elevator, and nothing seems so absurd as the American Gothic church. I know the English are just the same. They, too, erect Gothic churches, I have even seen a chapel made of galvanized iron fitted with an ogival window, but that is Europe, traditional old Europe, not modern America.

One might have expected America to realize that Christianity existed before Gothic architecture, and that there is no association between the two. America might have escaped from the thrall. This mechanical, conventional, worn-out Gothic, how disgusting, how outrageous it is to see it go up to-day! What wooden feeling that reveals! What lack of freshness, lack of courage! and to think that this rag doll of the ages should inhabit Brobdingnag! that Gothic—this ecclesiastical, ready-to-wear—should be accepted in the country which is to-day the sole possessor of a new architecture!

In Europe, architecture died in 1860, when the great Georgian style had given way to the porticos and columns of Victoria, and to the bar-racks of Baron Haussmann. Then creation ceased. Of late years the English history of architecture, particularly in domestic work, is a horrible

orgy of mongrel Elizabethan and incoherent Renaissance. In Germany, originality suffered delirium tremens in the suburbs of Munich, where one could see plump and peaceful German families taking their coffee in Chinese-pagoda villas. Then came America and ferro-concrete. America discovered the natural use of the new material, and she discovered height. Americans have often told me that I am wrong; they argue that the origin of the skyscraper is to be found in the small size of Manhattan and the cost of land. That is not true, for the skyscraper is not confined to Manhattan. You find it in Boston, Chicago, even in Oklahoma, where land was not worth a nickel a foot. The truth is that American architects, who went for their training to Paris, had the fit of exaltation which in other times produced the greater styles. That is how they made the style of the present and it is magnificent. Some of the tall buildings are bad, some good. The architect has not everywhere equaled his dream, but in general he has all the time kept a firm hold on utility, the only safe companion for the man who builds. He has wasted no time and no money on the scrolls and garlands which disfigure English building; he has not broken up his noble columns with irrelevant stone cubes. He has used no columns at all except to support something. So far as possible (that is after compromising with the demand for plate-glass ground floors) he has made honest use of his material. And so, by long lines, by avoiding fret, he has produced nobility. The Woolworth, the Wurlitzer, its neighbor, the Bush Terminal—all these, though rather elaborate, are clean-lined and good. Lit up at night, the Bush Terminal is a fairy castle in the air. The Commodore Hotel is perhaps the most magnificent of all because it is less narrow, has more dignity, and because its use of two materials is light and gay.

You find them all over the town, these landmarks of the new builders. Sometimes, as in the case of the Flatiron, the failure is horrible. At other times the result is dull, but in the main they make New York into a city of columns which support the sky. They mean something in terms of aspiration. It is not business alone which piles brick upon brick so fast opposite my window that every week a complete floor is built. Business thinks that it hires the architect, just as it thinks that it tolerates the poet, but the architect and the poet know better. In matters of art they always come through. The business men are too busy to watch over their own version of beauty, so the artist comes in and imposes his own.

Height is the new destination of American architecture. Even in the distant suburbs of Manhattan—at High Bridge, for instance—the twelve-floor building is here, and the cottage is not. The center of old respectable Manhattan can still be seen in Murray Hill, in Madison avenue, but here, too, height will ultimately prevail. You are very conscious of this tendency in the Mayfair of Manhattan, round about East Sixteenth street. The private houses are opulent, but their style is fretful and inferior to that of the office buildings. You can see that here money has toyed at leisure instead of wearying of design, as it has in Wall street, and giving over the work to the architect. Here are marble medallions, unnecessary pillars, slim, wrought-iron gates. You can imagine the rich woman who hunted the architect; you guess the husband away from home, indulging in frenzied finance. This feeling is continued in a less emphatic way in the district of Murray Hill, where the old predominates for a while.

In general, the private house is excessive in design. Here and there a white-stone face shines fine and pure, but few private buildings in New York are equal to the big apartment houses, such as those on Park avenue and Madison avenue, which are square and logical. The American

builds best when he builds high, but he must go all the way. His occasional failure appears in the houses of four or five floors. The effect is not narrow enough for him. Height and narrowness are essential to his new genius. It is curious to see the new products by the side of the old brick houses, colored with terra cotta, which, once upon a time the rich people from downtown built near Thirty-fifth street, to escape Manhattan. But Manhattan got them all the same.

I wonder what would have happened to Manhattan if the building law had not interfered; a time would have come when from the Battery to Forty-fifth street the whole island would have been covered with thirty-story buildings. The lower floors would never have seen the sun, and great hurricanes would have blown from the East River to the Hudson through the devil's corridors. It would have been epic. Now the buildings are set back in their upper floors; it is still fine, because it is big, but it is losing the nobility of the sheer facade. The new laws have saved old New York, for better or for worse. Probably for worse, as Old New York is an empty thing and the shade of Peter Stuyvesant a ghost out of place.

* * *

Hydrated Lime Increases Strength and Watertightness of Concrete

HYDRATED lime is the most plastic material of construction and for this reason it has been used for years in mortar, plaster and stucco. It is well known how easily it unites with water. After wetting it practically loses its granular character and is converted into an even colloidal paste that imparts smoothness and mobility to the concrete to which it is added.

Besides eliminating the larger, or visible, structural defects, it reduces the size of the smaller voids through internal lubrication which permits the particles of the aggregates to easily slide over and past each other, thereby causing them to range in a relative position which is the most advantageous for maximum density, and finally even these pores of greatly reduced size are filled with finely divided colloidal material.

Thus, it is seen that the important role of hydrated lime begins the moment it is brought in contact with the other materials and it would appear that its mission is fulfilled when its finely divided particles repose in the minute voids. But this is not the case. The water that is required to convert the hydrated lime powder into paste is held by it mechanically and this mechanical affinity for water retards the evaporation. After the cement has used up, for its early hydration, the water with which it is in direct contact, it draws on the moisture held by the hydrated lime and this serves to cause further hydration of the cement and the development of the colloid, which factors are of extreme importance for the increase of both strength and water-tightness. This must be apparent to all who know how important it is to keep the hardened concrete well supplied with moisture during its early age.



PANEL, DAVENPORT HOTEL, SPOKANE



PANEL, DAVENPORT HOTEL, SPOKANE

Wood Used in the Manufacture of Veneers

A PRELIMINARY comparative report on the quantity of wood consumed in the manufacture of veneers in the United States for 1919 has been issued by the Bureau of the Census, Department of Commerce.

The report was compiled in cooperation with the Forest Service, Department of Agriculture, and shows the quantity of wood used by principal States for the years 1909 and 1919. It covers the consumption of both domestic and imported woods in the manufacture of true veneers, as well as the grades used in the manufacture of barrels, baskets, boxes, crates, and "built up" lumber. Red gum furnished about 41 per cent of the total quantity used in 1919 as against 30 per cent in 1909.

The figures for the year 1919 are preliminary and subject to such changes as may be necessary from further examination of the reports.

WOOD USED IN THE MANUFACTURE OF VENEERS, 1919 AND 1909

(Number of establishments reporting for 1919, 362; for 1909, 637)

STATE	1919		1909	
	Quantity (Feet B.M.)	Per cent Distribution	Quantity (Feet B.M.)	Per cent Distribution
Total.....	637,520,000	100.0	435,981,000	100.0
Arkansas.....	77,096,000	12.1	26,116,000	6.0
Delaware.....	61,000,000	9.6	3,657,000	0.8
Wisconsin.....	50,502,000	7.9	31,737,000	7.3
Florida.....	43,936,000	6.9	33,293,000	7.6
Alabama.....	42,342,000	6.6	14,565,000	3.3
Mississippi.....	39,061,000	6.1	7,563,000	1.7
Tennessee.....	38,895,000	6.1	30,574,000	7.0
New York.....	38,571,000	6.1	24,218,000	5.6
North Carolina.....	30,423,000	4.8	19,984,000	4.6
Illinois.....	24,367,000	3.8	35,646,000	8.2
Indiana.....	24,254,000	3.8	31,472,000	7.2
Kentucky.....	22,971,000	3.6	19,356,000	4.4
Missouri.....	18,103,000	2.8	27,365,000	6.3
Georgia.....	14,863,000	2.3	6,980,000	1.6
Washington.....	14,329,000	2.2	5,419,000	1.2
Michigan.....	12,647,000	2.0	33,455,000	7.7
Maine.....	11,562,000	1.8	3,637,000	0.8
Louisiana.....	11,407,000	1.8	3,164,000	0.7
South Carolina.....	11,151,000	1.7	2,944,000	0.7
All other states.....	50,040,000	7.9	74,836,000	17.2

THE Architect and Engineer

INCORPORATED

Founded 1905 by E. M. C. WHITNEY

W. J. L. KIERULFF - *President and Manager*
 FRED'K W. JONES - *Vice-Pres. and Editor*
 L. B. PENHORWOOD - *Secretary*
 T. C. KIERULFF - *Attorney*

ASSOCIATE EDITORS

IRVING F. MORROW - *Architectural Critic*
 CHAS. H. CHENEY - *City Planning and Book Reviews*
 WILBUR DAVID COOK, *Landscape Architecture*
 WM. B. GESTER, *Inspection and Tests*
 O. P. SHELLEY, C. E., *Fireproof Construction*
 F. W. FITZPATRICK
 T. RONNEBERG, C. E., *Structural Steel*
 W. H. LOWE *Roofs and Roofing*
 FRED'K N. WOODS, JR., *Rock and Gravel*
 W. H. GEORGE *Cement*
 CHAS. FELIX BUTTE *Electrical Construction*
 I. W. FRICKE, *School Equipment*
 C. H. WHITE *Hardwood*
 WILL J. FRENCH, *Department of Safety*

Published Monthly in the Interest of the
 Architects, Structural Engineers, Contractors
 and the Allied Trades of the Pacific
 Coast by The Architect and Engineer, Inc.

PUBLICATION OFFICE:

627-629 Foxcroft Building, San Francisco
 Telephone Douglas 1828

Portland office: 210 Stock Exchange
 Building, Portland, Oregon.

The publishers disclaim any responsibility for statements
 made in the advertisements of this magazine

TERMS OF SUBSCRIPTION

(Including postage) to all parts of the United States \$2.50
 per annum - to Canada 75c additional; to all Foreign points
 \$1 additional

Vol. LXIV. June, 1921 No. 3

THE INSTITUTE CONVENTION

Continuation of the campaign for the utilization of the best architectural thought and skill in the construction of small dwellings—residences of six rooms or less—and the extension of structural service work, and the exchange of ideas on standardization, were outstanding features in the fifty-fourth annual convention of the American Institute of Architects in Washington, D. C., May 11, 12 and 13; a convention described by the Pacific Coast delegates, who recently returned home filled with enthusiasm, as the most helpful in the history of the organization.

All of these subjects had been prominent before the architects of the country during the year, and the consideration of them in the convention was, in many respects, a summing up of the results shown in their application. They will receive wider application next year;

indeed, the architects look upon them as furnishing one of the principal avenues through which the housing needs of the country must eventually be met, and a channel through which a revival of the building of residences and dwellings can be quickest accomplished.

Mr. Edwin H. Brown, chairman of the Committee on Small Houses, told the convention that a careful study of the causes and effects of the housing shortage of the country has been made in the last twelve months, and that efforts have been made to adjust the program of the committee so as to contribute as far as possible to the solution of the problem. Mr. Brown said in part:

"The plan of the small house service bureau covers the present small house problem and the incidental difficulties that are associated with it. It provides also for complete architectural service for the small home builder at a price that he can afford to pay. It is valuable because it costs something, and it pays a good return to the architect for his time and labor.

"The most important factor in this program is that it retains a local touch in small home building, but gives the knowledge necessary for the greatest economy in the construction of these houses. It eliminates 'lead pencil' house planning, and brings the architect into close intimate touch with all of the builders in his locality. It is educating the public to 'build right,' and to seek the aid of the specialist even in the small building task."

WHAT CHANCE HAS A BUILDING MORTGAGE?

The twelve Federal Reserve Districts, called upon to subscribe \$200,000,000 worth of 5½ per cent Treasury notes, turned in a tremendous over-subscription of \$532,000,000.

Is there any loose money in the United States? asks The Bulletin, official organ of the Associated General Contractors. Emphatically, yes.

Then why isn't this money available for building mortgages? That is another question.

As long as the nation is facing a period of reconstruction, and the operation of national economic laws make it a certainty that there will be a steady revival in business, however slow, there will be many good and sound investments offered, and there are a large number of these at present that are tax-exempt. At once there arises the question of tax-exemption for building mortgages. Many bankers and some economists object to this proposal, alleging that it gives rise to other evils such as decreasing the value of present realty holdings. Still these bankers cannot and will not loan money for building while they can purchase sound tax-exempt securities even at $5\frac{1}{2}$ per cent and the housing situation meanwhile becomes more acute.

It has also been proposed so to amend the banking laws that national banks may make loans from their savings departments on building mortgages. In Marion, Ohio, President Harding's home town, a newspaper raises the question as to whether or not such a course should be used to stimulate building. It says, "artificial stimulation at high prices will result in severe losses when the inevitable readjustment comes. The banks should not be in a position where large losses are possible from any one source." So there you are!

Senator Calder, of New York, in a recent talk told the City Club of Washington that "business men of America must back laws to encourage private housing construction, if they are to prevent the government in self-defense from going into the housing business itself."

If we are to have a considerable building revival it appears that there must be some drastic remedy in the very near future. New York City has tried the tax-exemption plan and is experiencing a real building boom. Other cities are considering the matter seriously.

Contractors who may raise their voices on this subject in their respective communities, would do well to give heed to the flood of good tax-exempt securities when considering objections raised by some bankers and property holders.

GAUGES OF THE UTILITY OF A STRUCTURE

There are many gauges of the utility of a structure as there are types of building. In a commercial structure the gauge is its earning capacity; in a private residence success is largely measured by the degree of comfort and convenience accorded its occupants; in a bank building or home for a financial institution the return may be based on an increased good-will or prestige, together with an ability through efficient arrangement to better serve the public. Whatever form the return the building represents an investment of capital for profit—and there can be no profit unless it meets the requirement imposed by the investment.

Notes and Comments

After having noted Mr. Edison's famous questions to prospective apprentices probably few have failed to be impressed with their own "amazing ignorance."

By propounding these questions, Mr. Edison has not only accomplished the primary purpose of segregating the sheep from the goats among the aspiring candidates for admission to the outer circles of his temple, but he has performed a salutary service in humbling an overproud human nature. It is only to be regretted that his list of questions was not longer.

The newspapers have published both questionnaire and answers and the inventor will have to puzzle his brain to suggest some more questions that will be as teasing as the odd list he has been feeding young college men for some months past

Mr. Edison's
Questionnaire
Incomplete

American Institute of Architects

(ORGANIZED 1857)

OFFICERS FOR 1920-21

PRESIDENT.....HENRY H. KENDALL, Boston
 FIRST VICE-PRESIDENT.....CHARLES A. FAYROT,
 New Orleans, La.
 SECOND VICE-PRESIDENT.....WM. B. FAVILLE,
 San Francisco
 SECRETARY.....W. STANLEY PARKER, Boston, Mass.
 TREASURER.....D. EVERETT WAID, New York

San Francisco Chapter

PRESIDENT.....G. A. APPELGARTH
 VICE-PRESIDENT.....EARNEST A. COXHEAD
 SECRETARY-TREASURER.....J. S. FAIRWEATHER
 DIRECTORS
 W. B. FAVILLE WM. MOOSER JOHN REID, JR.

Southern California Chapter

PRESIDENT.....EDWIN BERGSTRÖM
 VICE-PRESIDENT.....HENRY F. WITHEY
 SECRETARY.....R. GERMAIN HUBBY
 TREASURER.....ROBERT H. ORR
Executive Committee
 A. M. EDELMAN D. C. ALLISON S. B. MARSTON

Portland, Ore. Chapter

PRESIDENT.....W. C. KNIGHTON
 VICE-PRESIDENT.....JOHN V. BENNES
 SECRETARY.....FOLGER JOHNSON
 TREASURER.....O. R. BEAN
 TRUSTEES.....{ ELLIS F. LAWRENCE
 JOSEPH JACOBBERGER

Washington State Chapter

PRESIDENT.....CHARLES H. ALDEN, Seattle
 1ST VICE-PRESIDENT.....D. J. MYERS, Tacoma
 2D VICE-PRESIDENT.....A. J. RUSSELL, Tacoma
 3D VICE-PRESIDENT.....H. C. WHITEHOUSE, Spokane
 SECRETARY.....HAROLD O. SEXSMITH, Seattle
 TREASURER.....CARL SIEBRAND, Seattle
 DIRECTORS.....{ A. H. ALBERTSON
 I. S. COTE
 G. C. FIELD

California State Board of Architecture**NORTHERN DISTRICT**

PRESIDENT.....CLARENCE R. WARD
 SECRETARY-TREASURER.....SYLVAIN SCHNAITACHER

Members

J. R. MILLER EDWARD GLASS J. J. DONOVAN

SOUTHERN DISTRICT

PRESIDENT.....JOHN PARKINSON
 SECRETARY-TREASURER.....A. M. EDELMAN

Members

W. H. WHEELER MYRON HUNT W. J. DODD

San Francisco Architectural Club

President.....T. L. Pfeuger
 Vice-President.....Wm. Watson, Jr.
 Secretary.....L. A. Bryant
 Treasurer.....Wm. K. Dunnivant
 Directors—Pas. Brouhoud, F. G. Monk, S. D. Willard.

San Francisco Society of Architects

President.....W. C. HAYS
 Vice-President.....LEWIS P. HOBART
 Secretary-Treasurer.....H. H. GUTTERSON
 Directors.....{ GEO. A. LANSBURGH
 JOHN REID, JR.

Washington State Society of Architects

PRESIDENT.....HENRY H. JAMES, Seattle
 1ST VICE-PRES.....CLAYTON D. WILSON, Seattle
 2D VICE-PRES.....JULIUS A. ZITTEL, Spokane
 3D VICE-PRES.....WATSON VERNON, Aberdeen
 4TH VICE-PRES.....RICHARD V. GOUGH, Okanogan
 SECRETARY.....EDGAR BLAIR, Seattle
 TREASURER.....L. L. MENDEL, Seattle
 TRUSTEES—H. H. JAMES, FRANK FOWLER, A. WARREN GOULD, W. J. JONES, R. H. ROWE, all of Seattle.

American Society of Landscape Architects**Pacific Coast Chapter**

PRESIDENT.....W. D. COOK, JR.
 H. W. Hellman Bldg., Los Angeles, Calif.
 VICE-PRESIDENT.....STEPHEN CHILDS
 Fairmont Hotel, San Francisco, Calif.
 SECRETARY-TREASURER.....E. T. MISCHER
 Henry Bldg., Portland, Oregon

Tacoma Society of Architects

PRESIDENT.....Roland E. Borhek
 VICE-PRESIDENT.....Earl Dugan
 SECRETARY AND TREASURER.....A. J. Russell

San Diego Architectural Association

PRESIDENT.....WM. TEMPLETON JOHNSON
 VICE-PRESIDENT.....ROBERT HALLEY, JR.
 SECRETARY-TREASURER.....E. C. DECKER

American Society of Civil Engineers**San Francisco Association**

PRESIDENT.....M. M. O'SHAUGHNESSY
 1ST VICE-PRES.....W. L. HUBER
 2ND VICE-PRES.....F. R. MUHS
 SECRETARY AND TREASURER.....NATHAN A. BOWERS

BOARD OF DIRECTORS

W. L. HUBER
 F. R. MUHS M. M. O'SHAUGHNESSY
 E. J. SCHNEIDER NATHAN A. BOWERS
 Address all communications to the secretary, 502 Rialto Bldg., San Francisco.

Southern California Association

President.....H. W. Dennis
 First Vice-President.....R. J. Reed
 Second Vice-President.....F. D. Howell
 Treasurer.....E. R. Bowen
 Secretary.....F. G. Dessery

DIRECTORS—H. W. Dennis, Ralph J. Reed, F. D. Howell, E. R. Bowen, F. G. Dessery, G. G. Anderson, W. K. Barnard.

Address all communications to Secretary F. G. Dessery, 619-20 Central building.

American Association of Engineers

PRESIDENT.....L. K. SHERMAN
 FIRST VICE-PRESIDENT.....H. O. GARMAN
 SECOND VICE-PRESIDENT.....A. B. MCDANIEL
 R. W. BARNES.....Portland
 FREDERIC BASS.....Minneapolis
 B. A. BERTENSHAW.....Cincinnati
 W. C. BOLIN.....Chicago
 RAYMOND BURNHAM.....Chicago
 C. E. DRAYER.....Secretary
 National Headquarters, 63 E. Adams St., Chicago

SAN FRANCISCO CHAPTER

PRESIDENT.....G. CHESTER BROWN
 FIRST VICE-PRESIDENT.....W. H. PHELPS
 SECOND VICE-PRESIDENT.....L. D. HOWLAND
 TREASURER.....R. E. DODGE
 SECRETARY.....F. T. AMWEG

Permanent address, 960 Pacific Bldg.

LOS ANGELES CHAPTER

PRESIDENT.....CARL A. HEINZE
 FIRST VICE-PRESIDENT.....H. Z. OSBORNE, JR.
 SECOND VICE-PRESIDENT.....MYRON HUNT
 TREASURER.....E. H. MERRILL
 SECRETARY.....WILLIS S. PEPPER

Permanent address, 625 Metropolitan Bldg., Los Angeles.

and which drew from him the charge that the college graduate is an amazingly ignorant person.

Mr. Edison will find plenty of co-operation when he starts to enlarge upon his questionnaire. Every locality and every profession can supply some interesting interrogations that the well informed person should be able to answer.

Engineering and Contracting, published in Chicago, has volunteered a supplementary list which is appended below, followed by an interrogation or two of our own which we would like our readers to answer or enlarge upon before we send the questions on to the electrical wizard.

1. Who was the author of the Book of Zachariah?
2. What is the highest mountain in South Dakota?
3. In five-handed deuces wild, what is your chance of winning on a draw of three queens after two players have passed, one has stood pat, and the fourth has drawn three cards?
4. What is the full name of the present Ameer of Afghanistan?
5. What smells worse than a glue factory?
6. Why do girls cover their pretty ears with their hair?
7. What is a chersonese?
8. Who founded Paducah, Kentucky?
9. How is counterfeit money made?
10. What is the chemical composition of tabasco sauce?

And our own queries, some of which may call for a variance of answers:

1. Name the tallest building in San Francisco.
2. Name the largest city in California.
3. What is a gin fizz? Where is it obtainable?
4. What is the best example of architecture in San Francisco? The poorest?
5. What has become of the old-fashioned, cotton-hosed, rouge-less, you'll-make-a-good-wife-for-me girl?
6. What constitutes the final test of a building?
7. What is the difference between an architect and an architectural engineer?
8. What are the qualifications of an architect?
9. How many architects are there in San Francisco? In California? Pacific Coast?
10. By what method of building can construction be carried out most economically?

At least 1 per cent of the estimated cost of all large buildings erected in Chicago is set aside for the payment of graft to labor union leaders. This was the testimony of a Chicago architect, Mr. Walter W. Ahlschlager, before an Illinois legislative committee that is investigating building conditions in Chicago. We quote from the Chicago Tribune:

**Resist Grafters
in the Building
Trades**

Mr. Ahlschlager, who was architect for the Sovereign hotel, admitted he knew Goldberg had met the business agents in his office, but stated he did not know whether Krieg was present.

"What did you think they were up there for?" asked Attorney Fleming.

"Graft," replied the witness. "There is no doubt about that. That's easy. Goldberg had told me he had had trouble with these leeches from time to time."

The architect declared he had made provision for graft when he drew the specifications for the hotel.

"It was our custom in preparing a budget for a building to have a specific sum always set aside for graft," he said.

"As a matter of fact that is what every architect in Chicago does, doesn't he?" asked Mr. Fleming.

"That is what all architects do if they are careful."

"That is a general condition that exists in Chicago and has existed for a long time, is it not?"

"Yes."

"Have you or your organization ever done anything to stop it?"

"No."

"Instead of bucking it you accepted it?"

"Yes, it is something that exists just like the roof on the building. We always took precaution to see that the interest and overhead did not eat up the principal."

"How much do you set aside for graft?" asked Representative John P. Devine.

"Usually about 1 per cent. For instance, the Sovereign hotel cost about \$800,000, and the graft was fixed at \$8,000."

"So you only missed it by \$500?"

"Yes, we were ahead \$500."

It is almost incredible that many of the architects of Chicago have been parties in transactions such as this. No wonder Mr. Fleming asked, "Have you or your organization ever done anything to stop it?"

It is frequently argued by indi-

viduals that they are powerless to wage war against a well-entrenched organization of grafters and that, in any event, it is cheaper to pay the extortion than to fight the extortioners. Even nations have been known to pay tribute to pirates for the privilege of navigating the seas unmolested by them. But the argument is not only fallacious; it is cowardly. Any organization of professional or business men that takes "the easiest way" in avoiding a conflict with grafters is scarcely better than the grafters themselves.

The rottenness in the building trades of Chicago and New York is appalling. We are startled not so much by the general existence of graft as by the apathy among professional and business organizations, an apathy that has permitted evils to grow from pigmy to gigantic proportions with scarcely a publicly uttered hint that this evil development was in progress. It is true that occasional statements have been made in private to the effect that labor union leaders in the building trades were blackmailing certain individuals and firms, but the natural inference was that this graft was like any other class of criminality—an occasional act of an occasional crook, and not the everyday business of many men, as it seems now to have been.

The structural engineers, and indeed all professional engineers, in Illinois and New York, should at once join the architects in a determined effort to erase the evils that have brought into deserved ill repute the building trades of the two greatest cities in America.—Engineering and Contracting.

An incident is related of Mr. Henry C. Wallace, the new Secretary of Agriculture, which identifies him with the iron and steel business in an interesting way.

Several years ago the readers of the farm publication of which he is editor, made complaint of rapidly

rusting fence wire. Henry C. Wallace put their problem up to the Agriculture Department, the same as he would have done in case an inquiry had come regarding a mysterious disease among livestock. Instead of a sick hog, it was a case of sick steel.

The readers wanted to know why the wire fences they put up did not last like the old-fashioned wire fences their fathers had put up before them. Rust seemed to be playing havoc. The government metallurgists at Washington asked for specimens of old fence wire which has resisted corrosion, along with samples of the new fence wire which had rusted so rapidly, for the purpose of comparison and analysis. Young Wallace spent one whole week gathering the samples of old iron wire fences, some that had stood so long that the wooden cross bars had rotted away.

The specimens which he sent on to the Department of Agriculture at Washington were analyzed by the department metallurgist, and a bulletin was issued calling attention to the fact that modern rapid practice in steel making had left the metal full of impurities, as compared with the old-fashioned hand-made iron, and that the presence of these impurities caused the rapid corrosion of the new fence wire.

As a result of this little bulletin issued by the Agriculture Department, the manufacture of pure iron on a commercial scale was successfully undertaken, and the product not only applied to wire fences, but also to the different forms of sheet metal where rust resisting iron is an essential economy.

The Department of Agriculture made a notable contribution to the science of metallurgy in this discovery of the reason why steel and iron rust, and it is a matter of interest that Henry C. Wallace, who sent the first samples of rusted fence wire to Washington and thereby opened up this important investigation, is today heading the department.

How Secretary
Wallace Worked
a Cure for "Sick
Steel."

With the Architects

Building Reports and Personal Mention of Interest to the Profession

Personal

MR. H. J. BRUNNIER, consulting structural engineer of San Francisco, and Mrs. Brunnier, left May 25th, for a three months pleasure and business trip to the British Isles and Continental Europe. While absent Mr. Brunnier will make a special study of structural engineering and harbor development as practiced in European cities.

MR. G. F. ASHLEY, architect, formerly with Messrs. Palmer and Hornbostle of New York City, announces that he has opened offices for the practice of his profession in the First National Bank building, Oakland.

MR. L. H. FORD, formerly with the Hoosier Kitchen Cabinet Co., has resumed the practice of architecture with offices at 14th and Harrison streets, Oakland.

Announcement, A. S. L. A.

The Pacific Coast Chapter, American Society of Landscape Architects, would be glad to inform anyone interested as to the methods and standards of Professional Practice, laid down by the American Society. These standards have been established to protect the public against irregular practices, and to bring out the fact that the Professional Landscape Architect sells "experience in design and ability to direct work," and not "plants, labor costs, or materials, used in the execution of the work."

Any Landscape Architect, of recognized ability, who will subscribe to the standards of practice set by the American Society, is eligible for membership. A list of the Chapter's members may be had by addressing the secretary, Mr. Geo. D. Hall, I. W. Hellman building, Los Angeles.

Gold Medal for Mr. Johnson

Mr. Reginald D. Johnson of Pasadena has been awarded a gold medal by the American Institute of Architects in recognition of merit for the D. F. Paxton residence at Pasadena. This residence was recently adjudged one of ten notable examples of architecture by the jury in the contest conducted under the auspices of Southern California Chapter, A. I. A., and was illustrated in the August, 1920, number of *The Architect and Engineer*.

Granted Certificates to Practice

The following candidates were granted certificates to practice architecture at a meeting of the California State Board of Architecture, Northern Division, held on May 31st, 1921:

Frank E. Coombs, 111 Crocker building, San Francisco.

George B. Brigham, Jr., 1605 Del Mar avenue, Fresno.

Arthur Wm. Anderson, 635 Sutter street, San Francisco.

Honor for Mr. Bergstrom

Mr. Edwin Bergstrom, president of Southern California Chapter, A. I. A., was elected to membership on the board of directors of the American Institute of Architects at the recent convention held in Washington, D. C. Mr. Bergstrom's term of office is for three years. He is a member of the Municipal Art Commission of Los Angeles and was chairman of the Joint Technical Society for the past year.

Mr. Faville Re-elected

Mr. Wm. B. Faville, of Bliss & Faville, San Francisco architects, has been re-elected first vice-president of the American Institute of Architects. There is good reason to believe the 1922 convention of the Institute will be held in Los Angeles and it would be paying California a nice courtesy if Mr. Faville was elected president at this convention.

\$650,000 Oakland Hospital

Plans have been filed with the Oakland Municipal Building Department for a \$650,000 seven story reinforced concrete hospital for the Oakland Hospital Association. Mr. Maury I. Diggs is the architect. The association has decided upon a new location for the structure, namely, the block bounded by Summit, McClure, Twenty-ninth and Orchard streets.

Large Building for Taft

Mr. Orville L. Clark of Bakersfield, has completed plans for a large store and office building for the Midway Security and Investment Company at Taft, Kern county. One of the stores will be leased to the government for a postoffice. The building will cost \$75,000.

A Talk on City Planning

In a recent address in Sacramento on "City Planning," Dr. Carol Ironovici, city planning expert of Richmond and lecturer for the University of California Extension Division, told a good sized audience that the restrictions on buildings and zoning were not modern.

In the leading European capitals and cities, the speaker said, the high restrictions had been maintained for hundreds of years, with the result that the effect is very beautiful and harmonious.

Industries, he said, must find a location, and there is an advantage in keeping institutions of the same character together.

The speaker said zoning was not designed to prohibit and restrict, but to protect the residence districts, the home owner and also protect the industry. He said an industry will be glad to locate when properly served by railroads, and when it knows it will not be interfered with and asked to move later on.

Architect Files Suit

Mr. Kenneth MacDonald, Jr., architect of San Francisco, has filed suit in the Superior Court for \$4,600 from Mr. Harry Hill, for architectural services in the erection of a house and garage on the southwest corner of Broadway and Webster streets. He says a contract was made in September, 1919, whereby the architect was to receive \$3,900 for his services. Hill later ordered various changes and enlargements, which caused more work and brought the final cost from \$40,000 to \$85,000 the architect says, but refused to pay him more than \$3,900. The plaintiff says the reasonable value of his services is \$8,500.

Standard Oil Building

A new thirty-four story building will be erected on lower Broadway in the Bowling Green district, New York City, by the Standard Oil Company. The facades of the building will be of buff Indiana limestone in the style of the Italian Renaissance and will give an appearance of strength and solidity. The architects are Mr. Thomas Hastings of Carrere and Hastings, in association with Shreve, Lamb and Blake.

Another Hotel for Los Angeles

The Bowman Hotel Company will duplicate the St. Francis hotel at Fifth and Harper streets, Los Angeles, according to Mr. James Woods, Jr., manager. A large hotel is also contemplated by the same company in San Francisco.

\$200,000 High School

Mr. John C. Austin of Los Angeles, has prepared plans for a \$200,000 high school group for the Antelope Valley Union High School District at Lancaster.

Oakland Apartments

Messrs. Morrow and Garren, Chronicle building, San Francisco, have completed drawings for a \$20,000 frame and plaster apartment house for Mr. H. B. Abdy to be constructed at Fortieth and Telegraph avenues, Oakland. The same architects are preparing plans for a one story concrete bank building for the Bank of Lake, at Lakeport.

San Francisco Apartment House

Mr. M. V. Politeo, architect in the First National Bank building, San Francisco, has completed plans for a four story class C steel frame apartment house to be built on the south side of Bush street, west of Leavenworth, San Francisco, for Mr. John O. Titlow. There will be twelve high class apartments.

Practicing Architecture

Mr. Walter T. Steilberg, formerly head draftsman for Miss Julia Morgan, has opened an office at 908 Flatiron building, San Francisco, and has a large amount of work in prospect, including a five story class B club building in Berkeley.

Contract for Broadway Structure

Messrs. Righetti and Hirshfeld have let a contract to Del Favero and Rosori to build a two story reinforced concrete store and apartment building for Mr. A. Cariani on Broadway, San Francisco, at an approximate cost of \$20,000.

Another San Francisco Theatre

The Excelsior Amusement Company has commissioned Mr. G. A. Lansburgh to prepare plans for a store and theatre building on Mission street near Brazil, San Francisco, at an estimated cost of \$100,000.

Santa Clara High School

Construction of a \$200,000 reinforced concrete high school building at Santa Clara has been authorized by the school trustees of that city. Mr. W. H. Weeks is the architect. Bids will be opened July 5th.

Susanville Bank Building

Mr. Wm. Mooser has completed plans for a \$90,000 bank building of brick and terra cotta for the Lassen Industrial Bank at Susanville, California.

Berkeley Residence

Mr. John H. Momas, architect of Berkeley, is preparing plans for a \$6,000 home at Berkeley Heights for Mr. Walter Dodge.

Oakland Residence

Mr. D. C. Colman has completed plans for a \$12,000 residence to be built on Ashmont avenue, Oakland, for Mr. E. M. Greenwood.

"Kiss and Make Up," Says Polk

The following extracts are taken from Mr. Willis Polk's address at a luncheon of the Downtown Association in San Francisco May 25th:

Suggestion that the B. B. Committee immediately secure copies of all geographies in public schools all over the country and examine reference to California, with a view to insisting upon a fair presentation of the resources and possibilities of Central and Northern California. Assuming that from two to three million school children graduate annually, in a period of ten years we would have twenty to thirty million prospects to sell to.

San Francisco laughed at Los Angeles for annexing San Pedro and making plans for a harbor over 20 miles long with industrial and wharf spaces extending from the ocean beach to the heart of the business district of Los Angeles. The execution of this plan will place Los Angeles in a superior position, as to harbor facilities, even to our magnificent bay. Instead of laughing at Los Angeles we ought to laugh at ourselves.

Every city in the country contributes its quota of people who go to Southern California on account of its winter climate. San Francisco and Central California possess an equally good winter climate and a vastly superior summer climate. San Francisco ought to advertise its summer climate, for although people can get away from the blizzards of the East or protect themselves against them by artificial heat, housing and clothing, the unfortunate residents of New York, Chicago or other cities cannot protect themselves against the excessive heat of the summer except by going to Canada, the Rockies or other refuge, and above all other places, San Francisco.

The Chicago Commercial Club, following the Columbia Exposition of 1893, organized to develop Chicago's industrial and commercial welfare. They extended their territory from Manitoba on the north, to the Gulf of Mexico on the south, and from Lake Michigan to the Rocky mountains. The expansion of Los Angeles is the dream of a mere piker compared to the accomplishments of Chicago. The Chicago Commercial Club, after obtaining commercial supremacy for Chicago, then asked itself what it could do to make Chicago beautiful. This led to the adoption of the Chicago Plan as formulated by the Commercial Club and presented by the late Mr. D. H. Burnham. The Chicago Plan Commission is today at work with energy carrying out this plan.

The Chamber of Commerce plan, as presented by Dr. Rastall, for San Francisco and now turned over to a San Francisco Plan Committee, should be immediately adopted as a definite plan for the development of San Francisco and the entire community must be awakened to get behind it. Local sentiment in favor of the Burnham Plan must whole-heartedly get behind the Rastall Plan. There is absolutely no difference in the two plans. Every point in the Rastall plan is a mere fundamental preliminary detail in the final plan as proposed by the late D. H. Burnham. Beautification and adornment naturally follow industrial growth and commercial success. The San Francisco Plan Committee, after establishing our industrial success, will undoubtedly, like the Chicago Plan Commission, turn to making San Francisco attractive.

The innumerable obstacles, physical, financial, sentimental and selfish, that thwart, divert or delay the realization of an ideal plan, can be overcome by such a committee as is proposed for the San Francisco City Plan.

I suggest that we hold an "Armistice Week" and make up again. The trouble with our community is that we are a community of strong personalities, but we have not learned to do team work. Therefore by all means let us have a "Kiss and Make Up Week."

\$80,000 Grammar School

Mr. Jesse C. Peterson, architect of Sacramento, is preparing plans for an \$80,000 hollow tile grammar school building to be erected at Arbuckle. There will be six rooms and an auditorium.

Architects Selected for Montana State Buildings

The Montana State Board of Examiners have recommended appointment of the following architects to design new state buildings at a total cost of \$2,280,000:

State University—Library to cost \$250,000, plans by McIvor & Cohagen of Billings; heating plant at university to cost \$50,000, plans by Ole Bakke and C. J. Forbis of Missoula; gymnasium to cost \$225,000, plans by George H. Carsley of Helena; forestry building at university to cost \$100,000, plans by Ole Bakke of Missoula; residence for women at university to cost \$125,000, Link & Haire of Helena; residence for men to cost \$100,000, plans by Link & Haire of Helena.

State College at Bozeman—Engineering building to cost \$250,000, plans by Fred Wilson of Bozeman; engineering shops to cost \$100,000, plans by Fred Wilson of Bozeman; heating plant (building only) to cost \$50,000, plans by Fred Wilson of Bozeman; biology building to cost \$175,000, plans by George H. Shanley of Great Falls; gymnasium to cost \$225,000, plans by George H. Shanley of Great Falls.

State School of Mines—Metallurgical building to cost \$200,000, plans by Floyd Hamill of Butte.

State Industrial School—Cottage for boys to cost \$40,000, plans by Brynjuli Rivenes of Miles City; gymnasium to cost \$40,000, plans by W. A. Dedrick of Billings.

State Vocational School for Girls—Cottage for older girls to cost \$50,000, plans by Hugh Kirk of Helena; school building and laundry to cost \$50,000, plans by Hugh Kirk of Helena.

State Orphans' Home—Nursery to cost \$50,000, plans by Wellington Smith of Butte; gymnasium to cost \$40,000, plans by H. W. Howell of Butte.

State School for Deaf and Blind—Buildings and equipment to be decided upon later by board of education to cost \$200,000, plans by Marion B. Riffe of Kalispell and Arnold & Van House of Butte.

Competitive Designs for Bridges

Several Portland civil engineers in private practice have asked the state highway commission of Oregon to be allowed to submit competitive designs for the more important highway bridges of the state. They feel that they may be able to do this work more efficiently than it is done in the offices of the commission.

New Bank at Patterson

The Commercial Bank of Patterson will build a \$50,000 reinforced concrete building from plans by Messrs. Reed and Corlett, architects of Oakland. A contract has been let to the P. J. Walker Company and construction has been started.

Southern California Chapter, A. I. A.

Mr. J. Randolph Coolidge, Jr., architect of Boston and former president of the Boston Chapter, A. I. A., addressed the members of Southern California Chapter at Adobe Flores, South Pasadena. The subject of his address, which was well illustrated with stereopticon views, was "Notable Achievements in Architecture During the Past Six Years." The views shown were of buildings of all types, including public and semi-public buildings, office and utility buildings, collegiate buildings, churches, residences and small houses.

Mr. Coolidge stated that he had found much in California to interest him and highly praised our domestic and scholastic architecture. He was particularly impressed by the Spanish and Mission styles of architecture and charmed by the appropriateness of this style for Southern California.

Secretary Hubby announced that the candidacy of Edwin Bergstrom for director of the Institute had been endorsed by the San Francisco Chapter, Oregon State Chapter and Washington State Chapter.

Mr. Myron Hunt reported that the committee on education and publicity had selected and forwarded sufficient excellent material to fill the space allotted to the Chapter for the architectural exhibition in Washington.

President Bergstrom announced that Messrs. J. T. Zeller, Chas. F. Plummer, C. E. Noerenberg, Harold Johnson, G. B. Kaufman, H. C. Chambers, and William Richards had been elected to Institute membership.

A motion was passed instructing the secretary to extend a formal invitation to the Institute to hold the annual convention in 1922 in Los Angeles.

Oregon's New Arch Bridge

The Oregon City Arch, is to be built across the Willamette river at Oregon City, about sixteen miles south of Portland, Oregon. It will replace an existing cable suspension bridge which has been in use since 1886. The new structure will be a half through steel arch encased in gunite and flanked by reinforced concrete piers and approach viaduct. The arch will have a span of three hundred fifty feet and a rise of ninety feet. The construction will call for exceptional ability on the part of the contractors as it is impossible to use false work to erect the arch wings. The river at this point is from ninety to one hundred feet deep, which makes it impossible to use fixed falsework.

The design was prepared under the direction of Mr. C. B. McCullough, bridge engineer of the Oregon State Highway Commission.

Community Buildings

A community can "live around" from church building to church building, from school house to school house, from hall to hall, but so long as it lives that way it will never experience the distinct pleasure that comes from occupying a home of its own in the form of a community house. A good community house adds something to the life of the community, in the opinion of specialists of the United States Department of Agriculture, set forth in a lately published Bulletin entitled, "Plans of Rural Community Buildings."

Before a community decides the question of erecting a building, says this Bulletin, it should make a thorough study of the local situation. The study should show that an actual need for the building is felt by the various organizations of a public nature, and by the people themselves. It should demonstrate that the building can and should be maintained as a permanent institution. After it has been decided to erect a building, numerous questions arise, upon which the Bulletin gives much helpful information and many valuable suggestions, together with pictures and floor plans of a wide variety of community buildings now in actual use.

Plasterers' Efficiency

Recently a representative of the National Builder was talking with Mr. J. J. Campbell, vice-president of the Contracting Plasterers' Association of Louisville, Ky., on the present situation in the plastering business. On the question of efficiency, Mr. Campbell said: "The efficiency of plasterers has been declining for the past 10 years. We used to get 150 and 160 square yards of plastering done a day per man. Three years ago the production had dropped to 125 yards a day. Now we are getting from 80 to 100 square yards per day.

"I think we may look for some improvement in efficiency, but I do not believe we shall ever get back to 160 yards per day; for the boys who have learned the trade during the past few years have gotten into the habit of doing less than plasterers used to do.

"There is also another factor that is resulting in less quantity of work being done by the plasterers, and that is the policy of the plastering contractors, which is to do a higher quality of work, which is our best way of competing with the plaster board that is being put on the market and the use of which is seriously cutting into the volume of the plasterers' business. A higher quality of work means fewer yards per day per man."

Bridge to Span Bay Is Assured

A bridge capable of taking cars of steam, electric motor and pedestrian traffic, is to be built across San Francisco bay at a cost of \$25,000,000, to connect San Francisco with Oakland, Berkeley and Alameda, according to newspaper announcement by Mr. A. J. Rich of A. J. Rich & Co., realty dealers of 58 Sutter street, San Francisco. The amount necessary to put through the project has been assured by a corporation composed entirely of Californians, the report states. The corporation will charge tolls for passage over the new bridge. The rate will be far less than the present ferry fares and will cut crossing time two-thirds.

Mr. Gustav Lindenthal, noted New York bridge engineer, had passed upon the sites.

In an interview Mr. Rich said:

"It is to be a bascule bridge, approached by viaducts on either side, built each upon a square mile of reclaimed ground. At no other location than the one chosen is anything but a suspension bridge possible, which would entail a cost of at least \$75,000,000. But, with our plan, we will build it for \$25,000,000.

"The people interested are Californians, and they have the money. It is entirely a private enterprise. We will run it as a toll bridge, but of course, the municipalities on either side of the bay will be afforded the opportunity to take it over.

"Provision is made, in the plan, not alone for steam and electric traffic, but for unlimited motor and pedestrian traffic and for oil pipe lines.

"The construction of this bridge will develop some forty-six square miles of land on the San Francisco side, south of the city, and some 134 square miles on the Alameda side. It will give a direct terminal to the Southern Pacific, the Western Pacific and the Santa Fe railroads. The developed area will extend as far south as San Mateo, and to the south of Alameda on the east bay side.

"The first step to be taken is to get the permission of the government for the construction of our bridge terminals at the selected location. As soon as that is done, the bridge can be commenced, for I assert that we have the money available. I cannot make public at present the names of those in this enterprise.

"The bridge can be built, according to Lindenthal's assurance to me, within four years from the time work is started. A feature of its proposed construction at the selected site will be the creation, by means of the viaducts, of a tide channel of nine feet as far south as San Jose."

Office Building

Messrs. Weeks and Day, architects in the Phelan building, San Francisco, have completed plans for a four story reinforced concrete store and office building for Dr. Adler. The location is Mont-

gomery street, near Bush, and the estimated cost is \$150,000.

California State Buildings, Additions and Other Improvements

Following is a complete list of the bills passed by the California State Legislature at its recent session, appropriating money for new buildings, additions and improvements to various state institutions. Plans for the new work will be prepared in the office of State Engineer W. F. McClure and State Architect George B. McDougall, Forum building, Sacramento.

Completion of Riverside Farm.....	\$127,387
New Physics building, University of California, Berkeley.....	500,000
University Farm buildings, Davis.....	400,500
Completion of administrative building.....	100,000
Improvements, including street and ground work, Fresno Normal School.....	20,000
Completion of buildings and equipment, Humboldt Normal School, Eureka....	30,200
Improvement of grounds, Humboldt Normal School, Eureka.....	3,000
San Diego Normal School—	
Four units, new training school.....	24,000
Remodeling training school.....	18,000
Repairs to main building.....	30,000
Heat equipment.....	7,500
Improvement to grounds.....	5,000
Normal School buildings, San Francisco.....	290,000
(This is in addition to an appropriation of \$250,000 for a site.)	
Sau Jose Normal School—	
Home Economics building.....	180,000
Equipment of same.....	25,000
New well and tank.....	8,500
Miscellaneous repairs and improvements.....	18,000
Santa Barbara Normal School—	
Training school building and equipment	110,000
New sewer system.....	15,000
Improvements of grounds.....	5,000
Los Angeles Normal School—	
Repairs and improvements.....	70,000
New farm building.....	7,700
Completion of water and irrigation plant.....	10,000
Agnew State Hospital, Agnew—	
Buildings and equipment for employes	100,000
Miscellaneous improvements and equipment.....	33,500
Addition to dairy building.....	25,000
Mendocino State Hospital, Ukiah—	
New receiving building.....	150,000
Addition to kitchen and equipment.....	20,000
Completion of male tuberculosis cottage, Ukiah.....	7,000
Water supply.....	25,000
Shops and warehouses.....	19,360
Napa State Hospital, Napa—	
Nurses' home and equipment.....	50,000
Cottage and equipment for non-parole men patients.....	100,000
Septic tank.....	15,000
Steam distribution boiler plant and equipment.....	34,000
Occupational therapy shops	
General repairs and improvements.....	20,000
Air compressor, Napa.....	5,000
Norwalk State Hospital—	
Cottages for physicians and employes (2).....	400,000
Completion of employes' buildings and equipment.....	10,000
Furnishing convalescent cottages.....	13,000
Laundry equipment.....	5,000
Pacific Colony, Southern California—	
Eight cottages.....	70,000
Kitchen building, store room refrigeration.....	150,000
General farm buildings and equipment.....	35,000
Dam, pipe line and equipment.....	30,000
Industrial unit.....	20,000

Mechanical equipment	56,700
Improvements of grounds	10,000
Furnishings and equipment	24,000
Sonoma State Home—	
Two cottages for physicians.....	7,500
Quarters for employes	60,000
Cold storage and ice plant.....	21,500
Ten cottages for inmates.....	71,000
School and assembly hall.....	100,000
Laundry and kitchen equipment.....	15,500
General repairs and improvements.....	90,000
Southern California State Hospital—	
Patients' cottage	75,000
Industrial building	15,000
General improvements and repairs.....	45,000
Stockton State Hospital—	
Receiving and psychopathic building....	150,000
Addition to tubercular cottage.....	10,000
Septic tank and sewage	10,000
Repairs to roads	5,000
Horse barn at the farm.....	5,000
Tool shed and farm equipment.....	5,200
General improvements and repairs.....	50,000
Furnishings and equipment.....	25,000
California School for Girls—	
Three cottages (not voted).	
Repairs and general improvements,	
equipment and furnishings	45,500
Water supply	11,000
Preston School of Industry—	
Machine shop and equipment.....	35,000
General repairs	75,000
Six officers' cottages	18,000
Laundry building and equipment.....	23,000
Improving brick plant.....	15,000
Whittier State School—	
Cottages for boys, and equipment.....	45,000
Quarters for employes	43,000
New trades unit	15,000
Completion of school building.....	55,000
Water system and equipment.....	33,000
Repairs, improvements, equipment and	
furnishings	40,000
San Quentin Prison—	
Repairs and improvements.....	40,000
Machinery, equipment and tools.....	40,000
Cottages for employes	15,000
Folsom Prison—	
Five cottages	15,000
Completion of schoolhouse and assembly	
hall, Folsom	10,000
Repairs and improvements	32,000
Prison wall	10,000
Home for Delinquent Women—	
Alterations and additions	18,000
Farm buildings	6,000

Architect Dined

Mr. Edwin Bergstrom, who was elected a director of the American Institute of Architects at the recent annual convention at Washington, D. C., was the guest of honor at a luncheon of the Southern California Chapter, A. I. A., at the Athletic Club, Los Angeles, Friday, June 3. While the Pacific Coast Chapters had only about twenty-five votes out of a total of three hundred at the convention, they were successful in electing three of their members as officers of the Institute. Six members of the local Chapter were appointed on Institute committees. Mr. Bergstrom was appointed to the committee which will have charge of the complete reorganization of Institute activities. Mr. William B. Ittner of St. Louis is chairman of this committee. Mr. John W. Mitchell, an honorary member of the local Chapter and president of the Municipal Art Commission, spoke feelingly of the pride the members felt in the honor bestowed upon Mr. Bergstrom.

Stanley Garage Hardware Folder

A new four-page folder illustrating the No. 1780 Garage Hardware set, printed in two colors; size 3½ in. by 6½ in., has just been issued by the Stanley Works, New Britain, Conn. This folder illustrates the quality garage hardware set manufactured by The Stanley Works, for brick and concrete garages or where the doors require an offset.

The set includes the new cushion type of door holder No. 1773, also the large Cremona Bolt which fastens the door at top and bottom at one operation of the lever handle. The doors are swung on twelve and thirty-six inch Ball Bearing Hinges.

A copy of this new folder will be sent to readers interested in the product, on request.

Electrical Firm Makes Announcement

The Drendell Electrical & Manufacturing Company, designers and manufacturers of safety lighting panels, cabinets, and protective power panels announce under date of March 3, 1921, that they have acquired the good-will, machinery and stock of the switchboard department of the Standard Electrical Construction Company, San Francisco, and with these increased facilities expect to be able to render exceptional service.

The company's new plant is at 1345 Howard street, San Francisco.

"Armco in Picture and Fact"

The American Rolling Mill Company has recently published a new booklet, "Armco in Picture and Fact."

In this book the company has endeavored to follow the process of the manufacture of Armco Ignote Iron from the ore mine to the finished product in a very complete and effective manner, both in illustrations and text.

The effort has been along the lines of simplicity and directness in order to get the story of a high quality material across to the laymen with as few frills as possible.

Licenses Granted New Architects

The State Board of Architecture (Southern Division) has granted certificates to practice architecture to the following persons: Messrs Harry K. Vaughn, care of Carleton M. Winslow; William M. Ache, care of John Parkinson; Carl H. Boiler, 834 E. Mountain avenue, Pasadena; Winchester L. Risley, care of Carleton M. Winslow; Robert W. Snyder, San Diego; Paul R. Williams, care of John C. Austiu; Herman A. Reuter, 45 N. Euclid avenue, Pasadena; and C. Stanley Wyant, care of Noerenberg & Johnson.

With the Engineers

Reports from the Various Pacific Coast Societies,
Personal Mention, Etc.

Annual Meeting of American Association of Engineers

The annual meeting of The American Association of Engineers was held in Buffalo, N. Y., May 9 to 11. The convention went on record as endorsing the following activities:

Favoring an engineer on the International Boundary Commission.

Favoring a national board of classification for engineering schools.

Against laws permitting corporations to practice as engineers.

Favoring a census of highway traffic.

Favoring a continuance of Federal aid to highways.

Favoring Phipps bill increasing Federal aid allotment in public land states.

Favoring national financing of reclamation work.

Favoring sanitary engineers on public board of health.

Directing advance copies of annual convention reports be prepared.

Favoring a minimum of two weeks' notice by both parties in case of separations in employment.

Providing for committee to plan employment service and payment therefor.

Favoring increasing the membership from all classes of engineers.

Providing a committee to amplify statement of the ideals and objects of the association.

The convention was attended by 150 delegates representing 200 chapters.

New President of American Association of Engineers

Mr. H. O. Garman, chief engineer and consulting engineer for the Indiana Public Utilities Commission, and the Indiana Railroad Commission for more than 13 years, has been elected president of the American Association of Engineers which was in session at the Hotel LaFayette, Buffalo, N. Y., May 9 to 11.

Mr. Garman was the leader in putting on the statute books of Indiana one of the best engineer's and surveyor's license laws in the United States. He wrote standards for public utility service covering gas plants and electric plants and central-station heating plants, all of which are recognized as the best in the country. Prior to this work, he was for ten years a teacher of engineering at Purdue University. He is a member of

numerous societies including the American Railway Engineers Association, American Institute of Electrical Engineers, the American Society of Civil Engineers. He is also a past president of the Indiana Engineering Society and past vice-president of the American Association of Engineers.

The other officers elected by the Association are A. N. Johnson, dean of engineering at Maryland State College, vice-president; A. S. Morris, auditor, capital expenditures, C. & N. W. R. R., second vice-president; E. F. Ayres, Webster L. Benham, Garrison Babcock, Morris Bien, G. M. Butler, and W. R. McKeen were elected directors.

The American Association of Engineers has 25,000 members—the largest organization of engineers in the country, and the convention at Buffalo was unusually well attended. Among the important things under consideration were the utilization of technical knowledge in public service and the adequate distribution of engineering ability throughout the country, leading to better utilization of engineering knowledge.

Opens San Francisco Office

Mr. A. M. F. McSweeney, architect and structural engineer, has opened an office at 1014 Western States Life building, San Francisco, for the practice of architecture and structural engineering. Mr. McSweeney received his early training in Boston, New York and Pittsburg. He was for 10 years in charge of U. S. Army construction work.

Examination for Engineers

The next examination for Civil Engineers and Surveyors will be held in Boise, Idaho, on September 13th.

For application blanks and full information concerning this examination, write the Bureau of License, Capitol Building, Boise, Idaho.

Government in Business

Secretary Hoover, of the Department of Commerce, is taking up the matter of the nation-wide necessity for standardized building codes, and for once industry probably will not raise the objection of too much Governmental interposition in business.

The necessity of which Mr. Hoover is now taking cognizance for the Federal Government, is one which has long been known to the construction industry and is one of the matters with which the A. G. C. has concerned itself since the very beginning of its organization. An outline containing the essential features of a standard code prepared under the direction of the general manager was submitted to Secretary Hoover by Association headquarters, immediately following his announcement, and the hearty cooperation of general contractors pledged in support of the movement.

Secretary Hoover says he is informed that 10 to 20 per cent of the cost of building lies in the lack of standards—in a broad sense—and that there are some 260-odd building codes, to which a large portion of the building of the country must conform. If the Department of Commerce or any other Federal agency can bring about national, state, or local legislative remedies for such conditions the A. G. C. will heartily support such a movement wherever it may be initiated.

This is one case where a business improvement can be effected only through legislation, and legislation of this character calls for no expenditures, no appropriations, and would stimulate building everywhere as well as saving millions of dollars to those who pay the bills.—Associated General Contractors' Bulletin.

Fire Tests of Building Columns

The publishers are in receipt of an advance copy of the report on Tests of Building Columns, which have been conducted at Underwriters' Laboratories, Chicago, during the last four years, and published jointly by the Associated Factory Mutual Fire Insurance Companies, National Board of Fire Underwriters and the National Board of Standards.

This investigation, the only one of its kind ever made in America, was undertaken to obtain information on which proper requirements for the more general types of columns and protective coverings could be based.

In this book of nearly four hundred pages are chronicled the results of fire tests on ninety-one columns and fire and water tests on sixteen columns, all under load. Besides unprotected structural steel, cast iron, concrete filled pipe and

completely protected by concrete, hollow tile, brick, gypsum block, and metal lath and plaster were included to make the series representative of columns as used in building construction. The results with the data included in the report are a real contribution to building science. timber columns, the same types both partially and

California Highway Commission Plans Tests

EXPERIMENTS of interest and importance to road builders in every State of the Union are to be conducted in California under an arrangement which has just been entered into between the California Highway Commission and the United States Bureau of Public Roads.

The detail of the arrangement was announced by Mr. A. B. Fletcher, chief engineer of the California Highway Commission, following his return from a conference in Washington with Mr. Thos. H. MacDonald, chief of the Bureau of Public Roads.

Following an intensive investigation by the United States Bureau of Public Roads of soils which have given particular difficulty to road builders, it has been discovered that the difficulty with these soils, such as adobes and clays, generally lay in the presence in these soils of colloidal matter, a glue like substance capable of extraordinary absorption and retention of water. Colloids have been extracted from these soils, and the result has been that the soil has been left inert and deprived of its quality of absorption.

Experiments show that the colloids found in these soils are capable of absorbing and retaining water up to several hundred times the volume of the colloids.

The result of the discovery of colloids in these soils has been to change the trend of thought in highway construction.

The chief difficulty that highway engineers have found in building roads over these soils has been due to the large expansion and later contraction of

HARDWOOD HEADQUARTERS

ASH-BASSWOOD-BIRCH
AROMATIC RED CEDAR
COTTONWOOD-ELM-HOLLY
SOUTHERN RED GUM
HICKORY-LAUREL-MAPLE
OREGON MAPLE-PLAIN OAK
-QUARTERED OAK-
WYBROOK BENDING OAK
POPLAR-WALNUT



BOXWOOD-EBONY-IRONBARK
JENISERO-KOA-SPANISH CEDAR
LIGNUMVITAE-MAHOGANY
ROSEWOOD-TEAK-RED BEAN
SPOTTED GUM-CIRSIAN WALNUT

LUMBER-TIMBER
HARDWOOD FLOORING
WYBRO VENEERED PANELS
DOWELS-TREENAILS-VENEERS

WHITE BROTHERS

FIFTH and BRANNAN STREETS

SAN FRANCISCO, CAL.

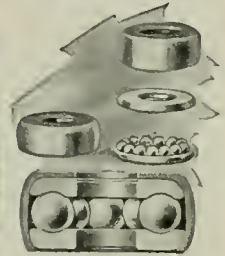
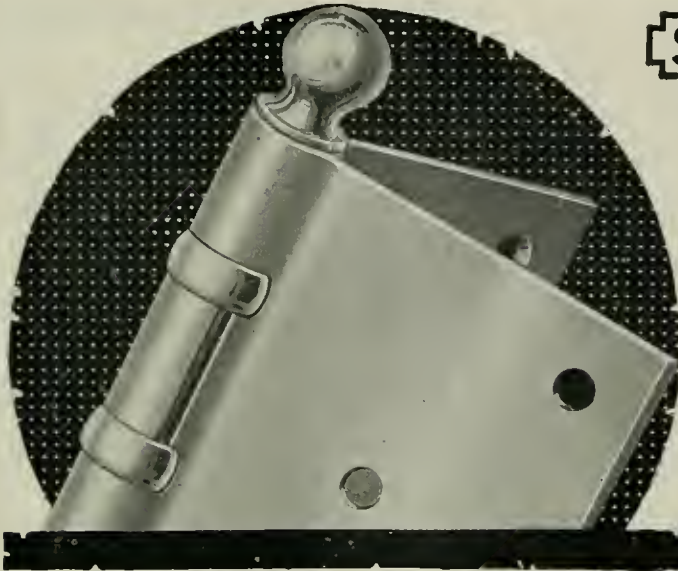

Dust and Dirt Proof,
Non-detachable,
Ball Bearing Washers

STANLEY BALL BEARING BUTTS and the *Other* STANLEY Products

YOU are undoubtedly familiar with Stanley Ball Bearing Butts—their permanent strength and ease of operation. You have probably recommended Stanley Butts on the buildings you have planned.

Are the other Stanley products equally well known to you? Stanley Garage Hardware, Screen Door Hardware, Storm Sash Hardware and Rolling Door Hardware are *Wrought Steel* productions of the highest type,—worthy of your strongest recommendation.

*May we send you the various
catalogs? Write for A E 6*



When writing to Advertisers please mention this magazine.

The Contractor

BUILDING CONSTRUCTION, BRIDGES AND
ROAD WORK

Contracting — As Seen Through an Architect's Eyes*

By CHARLES A. DIEMAN, Architect

AFTER the armistice, came a few months of depression, and then the reaction set in. A period of spending was inaugurated—and the sky was the limit. There was plenty of money—and the people had to spend it. Prices? They were the least of our troubles. The higher, the better! We were having the time of our lives. And the building industry boomed along with everything else. But it seems to be a proven fact that where a man will stand paying the highest market price for any other commodity he has a strong aversion to financing a building proposition on the same basis. He takes the attitude of the man who was getting a shave. The Irish barber asked, "How is the razor, sorr? Does it go easy?" "Well," answered the sufferer, "what's the operation? If you're merely skinning me it goes tolerable easy, but if you're shaving me it goes hard."

So, one day there was a change. Conditions were reversed and the bottom fell out of the business—fell with such a thud that we are still hearing the echoes. And who has borne a good deal of the blame? Who has been reviled and censured—and called a profiteer? The contractor and the material man! I'm not saying that they haven't made money, but I do say that they have not been primarily at fault. Had the people stopped to take stock they would have seen this—that after the depression, when everyone tried to build at once, the result could only be demoralization—in transportation, labor, materials, and financing. They would have realized that the political situation had a good deal to do with the building situation. There was a tightening of the money market, and owners could not finance building projects.

As far as transportation of building materials (and other commodities) was concerned, for months the railroads were in very bad shape. When everyone started to build, the natural result was

congestion, and sometimes people had to wait for weeks, and even months, for delivery of materials. The contractor could resort to the use of the railway express and motor trucks, but these were expensive, and as far as cost was concerned there was not much difference between that and the costs entailed by the extensive delays in shipment by freight.

LABOR'S ATTITUDE HAS BEEN GREATEST PROBLEM IN BUILDING INDUSTRY.

Then, too, even had transportation conditions been normal, the output of building materials could not have met the demands. At the close of the war there were not enough building materials on hand to supply a quarter of the demand for construction work. These conditions could not be remedied in a day, and the inability to produce building materials in quantities needed naturally resulted in high prices, both on account of non-production and delays.

But, there is no doubt that the most disturbing element in the building situation has been the attitude of labor. During the war, for every man taken into the service there was a vacancy created. When one takes into consideration that this affected millions of jobs one can realize the result—the individual worker found himself commander of the situation. He worked about as suited his will, and I am afraid the government itself had a good deal to do with his attitude. As in the other cases, conditions could not readily be changed on a moment's notice because the position of the mass of labor could not be altered in a day. The disposition to work was much diminished, and as a result there was a great decrease in efficiency. It has been interesting to note the figures compiled by different organizations covering building costs. The associated employers of Indiana, in giving different wage rates and production records, show that since 1909 the cost of laying brick has gone up from 55 cents an hour to \$1.25 in 1920. They further show that whereas 1,100 bricks were laid in a day in 1909, 541

*Extracts from an address before the Master Builders of Iowa.

bricks a day were laid in 1920—the cost having risen from \$4.40 for the laying of 1,100 bricks to \$10.00 for 541 bricks, while the rate per hour has more than doubled, the efficiency has decreased more than one-half. In other words, it cost four times as much in 1920 to lay 1,000 bricks as it did in 1909. That condition, in part, applied to nearly every other trade concerned in building.

Labor made all sorts of demands, which were met. In one instance, in Chicago, union carpenters worked on a \$1,750,000 building until it was two-thirds completed, and then went fishing from Monday to Saturday noon, and worked Saturday afternoon and Sunday at pay based on double time—not for \$1.25, but for \$2.50 an hour. Mr. E. A. Beals, of Dow's Reports, has traced the volume of building, and the cost thereof, from 605 million square feet, costing \$1.50 per square foot in 1911, to 350 million square feet for the first nine months of 1920, at a cost of \$3.50 per square foot. While some articles were exorbitantly priced, others had to be abnormally priced because of their chief essential—labor. The uncertainty and risk was very great, and this could only mean a high rate of overhead. In addition, there had been added government taxes and other expenses. As a result, increases in cost of production, and consequently in selling prices, has been passed along from one to another. The contractor cannot be blamed for that.

Taking it all in all, it is small wonder that there was a drain on the money market, and the banks finally began to refuse loans to finance building projects. Last June, a trust banker, Benjamin A. Bills, in speaking to the Illinois Society of Architects of the financial conditions in connection with buildings, said: "We were hopeful that the silver lining in this cloud of adversity would be a consequent over-production, which would mean the bringing down of war-time prices. Instead, labor, as you well know, has become tired or retired." Mr. Bills related a conversation which had taken place between a builder, a banker and a labor union organizer. The organizer had made a boast that his plumbers would soon be getting \$2 an hour. The banker rather bitterly retorted, "I hope they get \$5 an hour, for then we shall sooner return to the rule of reason, which is based on a value received relation. For every dollar above \$1 an hour which you get your plumbers, they give no value back in their labor upon which I can successfully hope to get a return dollar on building loans so made. This means," he continued, "that I simply must refuse to loan the savings of your plumbers on work which your plumbers



Reynold H. Hinsdale, Arch't.

The Finishing Touch

Architects agree that Bay State adds the final touch of beauty to all buildings of cement and stucco. And it protects—for Bay State Brick and Cement Coating waterproofs walls of brick, cement and stucco. Dampness will not seep in. Driving rains cannot beat through it. Write for samples in white and colors, and Booklet No. 43.

WADSWORTH, HOWLAND & CO., Inc.
Paint and Varnish Manufacturers
Boston, Mass.

JAMES HAMBY & SON, REPRESENTATIVES
304 Crocker St. 268 Market St.
Los Angeles. San Francisco.

BAY STATE
Brick and Cement Coating

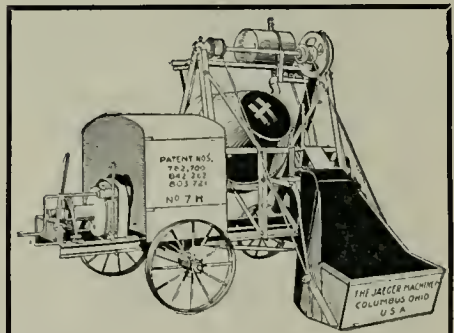

NOT ONLY MIXERS

but a full line of nationally-known equipment, as well.

We have prepared for a brisk building season.

"Get it from BACON"

Edward R. Bacon Company

51 Minna St., San Francisco

165 E. Jefferson St.
Los Angeles

When writing to Advertisers please mention this magazine.

The Contractor

BUILDING CONSTRUCTION, BRIDGES AND
ROAD WORK

Contracting — As Seen Through an Architect's Eyes*

By CHARLES A. DIEMAN, Architect

AFTER the armistice, came a few months of depression, and then the reaction set in. A period of spending was inaugurated—and the sky was the limit. There was plenty of money—and the people had to spend it. Prices? They were the least of our troubles. The higher, the better! We were having the time of our lives. And the building industry boomed along with everything else. But it seems to be a proven fact that where a man will stand paying the highest market price for any other commodity he has a strong aversion to financing a building proposition on the same basis. He takes the attitude of the man who was getting a shave. The Irish barber asked, "How is the razor, sorr? Does it go easy?" "Well," answered the sufferer, "what's the operation? If you're merely skinning me it goes tolerable easy, but if you're shaving me it goes hard."

So, one day there was a change. Conditions were reversed and the bottom fell out of the business—fell with such a thud that we are still hearing the echoes. And who has borne a good deal of the blame? Who has been reviled and censured—and called a profiteer? The contractor and the material man! I'm not saying that they haven't made money, but I do say that they have not been primarily at fault. Had the people stopped to take stock they would have seen this—that after the depression, when everyone tried to build at once, the result could only be demoralization—in transportation, labor, materials, and financing. They would have realized that the political situation had a good deal to do with the building situation. There was a tightening of the money market, and owners could not finance building projects.

As far as transportation of building materials (and other commodities) was concerned, for months the railroads were in very bad shape. When everyone started to build, the natural result was

congestion, and sometimes people had to wait for weeks, and even months, for delivery of materials. The contractor could resort to the use of the railway express and motor trucks, but these were expensive, and as far as cost was concerned there was not much difference between that and the costs entailed by the extensive delays in shipment by freight.

LABOR'S ATTITUDE HAS BEEN GREATEST PROBLEM IN BUILDING INDUSTRY.

Then, too, even had transportation conditions been normal, the output of building materials could not have met the demands. At the close of the war there were not enough building materials on hand to supply a quarter of the demand for construction work. These conditions could not be remedied in a day, and the inability to produce building materials in quantities needed naturally resulted in high prices, both on account of non-production and delays.

But, there is no doubt that the most disturbing element in the building situation has been the attitude of labor. During the war, for every man taken into the service there was a vacancy created. When one takes into consideration that this affected millions of jobs one can realize the result—the individual worker found himself commander of the situation. He worked about as suited his will, and I am afraid the government itself had a good deal to do with his attitude. As in the other cases, conditions could not readily be changed on a moment's notice because the position of the mass of labor could not be altered in a day. The disposition to work was much diminished, and as a result there was a great decrease in efficiency. It has been interesting to note the figures compiled by different organizations covering building costs. The associated employers of Indiana, in giving different wage rates and production records, show that since 1909 the cost of laying brick has gone up from 55 cents an hour to \$1.25 in 1920. They further show that whereas 1,100 bricks were laid in a day in 1909, 541

*Extracts from an address before the Master Builders of Iowa.

bricks a day were laid in 1920—the cost having risen from \$4.40 for the laying of 1,100 bricks to \$10.00 for 541 bricks, while the rate per hour has more than doubled, the efficiency has decreased more than one-half. In other words, it cost four times as much in 1920 to lay 1,000 bricks as it did in 1909. That condition, in part, applied to nearly every other trade concerned in building.

Labor made all sorts of demands, which were met. In one instance, in Chicago, union carpenters worked on a \$1,750,000 building until it was two-thirds completed, and then went fishing from Monday to Saturday noon, and worked Saturday afternoon and Sunday at pay based on double time—not for \$1.25, but for \$2.50 an hour. Mr. E. A. Beals, of Dow's Reports, has traced the volume of building, and the cost thereof, from 605 million square feet, costing \$1.50 per square foot in 1911, to 350 million square feet for the first nine months of 1920, at a cost of \$3.50 per square foot. While some articles were exorbitantly priced, others had to be abnormally priced because of their chief essential—labor. The uncertainty and risk was very great, and this could only mean a high rate of overhead. In addition, there had been added government taxes and other expenses. As a result, increases in cost of production, and consequently in selling prices, has been passed along from one to another. The contractor cannot be blamed for that.

Taking it all in all, it is small wonder that there was a drain on the money market, and the banks finally began to refuse loans to finance building projects. Last June, a trust banker, Benjamin A. Bills, in speaking to the Illinois Society of Architects of the financial conditions in connection with buildings, said: "We were hopeful that the silver lining in this cloud of adversity would be a consequent over-production, which would mean the bringing down of war-time prices. Instead, labor, as you well know, has become tired or retired." Mr. Bills related a conversation which had taken place between a builder, a banker and a labor union organizer. The organizer had made a boast that his plumbers would soon be getting \$2 an hour. The banker rather bitterly retorted, "I hope they get \$5 an hour, for then we shall sooner return to the rule of reason, which is based on a value received relation. For every dollar above \$1 an hour which you get your plumbers, they give no value back in their labor upon which I can successfully hope to get a return dollar on building loans so made. This means," he continued, "that I simply must refuse to loan the savings of your plumbers on work which your plumbers



Reynold H. Hinsdale, Arch't.

The Finishing Touch

Architects agree that Bay State adds the final touch of beauty to all buildings of cement and stucco. And it protects—for Bay State Brick and Cement Coating waterproofs walls of brick, cement and stucco. Dampness will not seep in. Driving rains cannot beat through it. Write for samples in white and colors, and Booklet No. 43.

WADSWORTH, HOWLAND & CO., Inc.
Paint and Varnish Manufacturers
Boston, Mass.

JAMES HAMBY & SON, REPRESENTATIVES
304 Crocker St. 268 Market St.
Los Angeles. San Francisco.

BAY STATE
Brick and Cement Coating

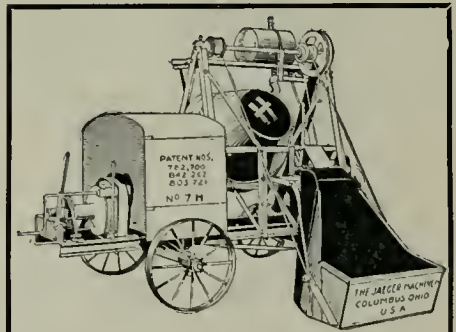

NOT ONLY MIXERS

but a full line of nationally-known equipment, as well.

We have prepared for a brisk building season.

"Get it from BACON"

Edward R. Bacon Company

51 Minna St., San Francisco

165 E. Jefferson St.
Los Angeles

When writing to Advertisers please mention this magazine.



BUILDING BUSINESS

CALIFORNIA'S OLDEST NATIONAL BANK
HAS BEEN A VITAL FACTOR IN THE UPBUILDING
OF SAN FRANCISCO AND THE ENTIRE WEST.

WHEN LAYING PLANS FOR THE FUTURE OF YOUR
BUSINESS CONSULT THE OFFICERS OF THIS INSTITUTION

THE FIRST NATIONAL BANK OF SAN FRANCISCO

Affiliated with
FIRST FEDERAL TRUST COMPANY
Combined Resources \$60,473,521.88

are doing, and that, therefore, they can have and will have less work, and finally no work to do." All this, of course, took place months ago, and conditions have changed considerably.

As for the future, we can make no sure prophesy. It seems to me that the situation has been bettered, and is slowly but surely approaching normality.

I believe that labor is assuming a fairer attitude towards its employer. There seems to be hopeful signs in the efforts of their organizations to do the right thing. They realize that a change is necessary. Not only will it be necessary to reduce the cost per hour, but it will have to increase its producing power. During the war, and since, labor has been only from 50 per cent to 70 per cent efficient. When you bring this up to 100 per cent efficiency one can see that it will make a great difference in the cost of any work.

TIME IS COMING WHEN OWNER WILL NOT TOLERATE INEFFICIENCY.

All of us, whether architect or contractor, have let down our steam pressure, and we have all been taking it easy, much like the laboring class. But I think the day is near at hand when the builder—I refer to the owner, or client—on whom we rely for our work, whether it be residence or public buildings—will not tolerate our inefficiency, and it's up to us to change our own methods before we blame the other fellow for all the trouble. There is much to say about union labor and its power with its jurisdictional rulings. May be good or evil, I cannot say, but leave that for you. Only, let us be perfectly frank in our deliberations and be careful that we do nothing that in the eyes of the public seem unfair. Transportation facilities are better, and though freight rates are much increased the actual cost of delivery is less. The money situation is much relieved. We are looking forward to four years of sound governmental administration.

It must be remembered that there is nowhere in the building industry a large surplus of building material supplies. If there is a stampede toward building, it seems only logical that the high prices will still prevail—and not only that—another congested period. Construction can utilize about all the materials available, and this should be taken into consideration.

So, it seems to be that the situation calls for cooperation more than ever before—cooperation between architects, between contractors, between all professions and trades bearing on the building industry. If we will all recognize that we should do everything possible to improve conditions we shall soon return to a basis of living which should be entirely satisfactory.

TRANSMISSION EQUIPMENT

For Mill or Factory



Pulleys ---	Shafting ---	Gears ---
Hangers --	Bearings --	Take Up --
Sprockets -	Clutches -	Chain Belts -
Floor Stands	Belt Tighteners	Rope Sheaves

Meeseco Short Center Drives

Meese & Gottfried Company

ENGINEERS AND MANUFACTURERS

CONVEYING, ELEVATING, SCREENING
AND MECHANICAL POWER TRANSMITTING
MACHINERY

SAN FRANCISCO 662 Mission Street	SEATTLE 559 First Ave. So.	PORTLAND 67 Front Street	LOS ANGELES San Pedro & E 34th
-------------------------------------	-------------------------------	-----------------------------	-----------------------------------

When writing to Advertisers please mention
this magazine.



Copyright, 1921, by National Terra Cotta Society

Drawing by Hugh Ferriss

CONNECTICUT AVENUE APARTMENTS

Light ivory matt glazed Terra Cotta

WASHINGTON, D. C.

Hunter & Bell, Architects

MODERN SOLUTIONS of MODERN PROBLEMS

WITH the variety of special problems in design, construction, and material that tests his imagination and resourcefulness in these days, the architect is fortunate in having at hand a wide variety of versatile and economical materials.

Chief among these is Terra Cotta—ancient of lineage, but as logical a decorative facing material today as it was in the days of Renaissance Italy.

In the average apartment house the problem has been: "Maximum architectural effect with minimum initial cost." The solution, obvious and irrefutable, is "Terra Cotta."

This, combined with a pronouncement of the architect's importance, forms the substance of a series of exceptional advertisements placed each month, for the education of the reading public, in the pages of *The Literary Digest* by National Terra Cotta Society.

NATIONAL TERRA COTTA SOCIETY is a bureau of service and information. Its publications cover not only the technical and structural use of the material but show, as well, examples of its application to buildings of various types.

Brochures of specific value, as indicated by their titles, will be sent to architects on request addressed to National Terra Cotta Society, 1 Madison Avenue, New York, N.Y.

The School The Theatre The Garage
The Store The Bank

These brochures consist of a selection of illustrations, with text and comment, showing Terra Cotta buildings of the respective types.

Terra Cotta—Standard Construction

A valuable technical reference work for architects and engineers.

Terra Cotta Defined

This new booklet, primarily intended to inform the layman, will nevertheless prove interesting to architects who like to review buildings the country over.

TERRA COTTA

Permanent

Beautiful

Profitable

Contractors and architects could do much toward remedying some of their difficulties, and establishing more friendly relations. There has always been a good deal of friction, much of it unwarranted, but it seems to me a good deal of this could be done away with. It may seem visionary to you, but I wonder if a standing committee known as a grievance committee, to which all complaints of architect and contractor might be presented and action taken, would not help remedy matters. This might have a tendency to ease people's feelings if they think they are unjustly criticized. This committee could take up any question arising among contractors or architects, in which arbitration is desirable, and possibly the decision of the committee might have a great influence in preventing law suits.

The architect's committee on standardization of plans is out to help solve some of the problems. We have just started the ball rolling, but we feel confident that when the committee gets things in working shape it will mutually benefit, in innumerable ways, both architect and contractor. When this standardization committee was appointed in the chapter it was not solely to aid the contractors, but more from the architect's standpoint. It has always been hard for an architectural draughtsman, upon going into a strange office, to adapt himself to new methods of planning, new symbols and signs. Naturally, it takes some time to learn these, which, of course, results in a good deal of lost time. So, you may see for yourselves that when this committee was appointed it was primarily for the benefit of the architects. But there is no reason why good cannot be accomplished by cooperation between architect and contractor.

General Contracting an Honorable Profession Today*

By W. O. WINSTON,
President American General Contractors

THE General Contractor, in common with the engineer, architect, mechanic and laborer, is a cog in a machine that makes for civilization and progress. He is both proud and happy to be in such company for such work. He is not concerned whether his cog be large or small,

*Address delivered at dinner of Executive Board and guests, Washington, D. C., May 10.



The Stability of Dunham Standards

THE experimenting which determined the principle of the Dunham Radiator Trap ended twenty years ago.

In specifying Dunham Radiator Traps, and other Dunham Specialties, you place your confidence in standards that have matured, that will never be sacrificed to commercial expediencies.

C. A. DUNHAM COMPANY
Los Angeles San Francisco Seattle
Portland Spokane
Administrative and General Offices
CHICAGO, ILLINOIS

but whether it be large or whether it be small, he is concerned in having it so function that the master may say, "Well done, good and faithful cog."

In a nutshell, it is the rule and not the exception that the first concern of the General Contractor is for his reputation—reputation for skill and integrity—realizing that on that, more than anything else, depends not only his success, but his happiness in business.

And now for a few minutes I shall speak about some things which are not germane to my text.

The construction game is not what it was when I sat in some forty-five years ago. The cards are different, the rules are different, and, speaking generally, the players are cleaner and squarer. In this time I have seen the steam shovel take the place of the pick and shovel; locomotives and cars of large capacity take the place of the wheelbarrow and the horse cart, and so on down the line. Through the instrumentality of these improved implements of construction, it is possible to do in three months now what would have

QUALITY

A. QUANDT & SON

ESTABLISHED 1885

SERVICE

OFFICE and SHOP
374 GUERRERO St
Market 1709

SAN FRANCISCO, CAL.

PAINTERS AND
DECORATORS

180 JESSIE STREET
Sutter 6700

taken twelve months then, and yet it will surprise many of you when I say that the unit cost of work has increased rather than decreased.

Fifty years ago, at least in the state of my birth, contracting was not considered to be a vocation of a gentleman. It was work for the roughneck and overseer. But now there as well as elsewhere, it is an honorable profession, second to none.

It is distinctly a creative and strenuous profession and that is why it appeals so strongly as it does to men of vision, courage and good red blood.

Declare for Open Market

The following resolution, recommended by the Executive Committee, was unanimously adopted by the Southern California Chapter of the Associated General Contractors:

Whereas, It is our duty as an association to hold ourselves aloof from all combinations denounced by the laws of the United States, or detrimental to the public interests.

Therefore, be it resolved, That this Association is unqualifiedly in favor of an open market for all materials needed in the construction industry, and is resolutely opposed to all combinations, whether of manufacturers or contractors, whereby prices are fixed on the market or controlled in favor of any particular interest and against the interests of the general public; and

Resolved further, That we are equally opposed to any combination whether of labor unions or contractors, whereby the right to seek or furnish employment is limited to any particular class of persons, members of any association, organization or union, and that we are heartily in favor of the principle, as declared by President Roosevelt's Coal Strike Commission of 1902, to wit: "That no person shall be refused employment or in any way discriminated against on account of membership or non-membership in any labor organization, and that there shall be no discrimination against or interference with any employee who is not a member of any labor organization by members of such organization."

THE GARDEN

AFTERNOON TEA
FROM 4 TO 6
Concert Orchestra

— — —

AFTER THEATRE SUPPER
DANCING 9 TO 1
Music By
Art Hickman's Orchestra.

HOTEL ST FRANCIS
MANAGEMENT
THOS. J. COLEMAN

Recent Installations of Wilson Rolling Doors and Folding Partitions

Among the recent installations of Wilson Folding Partitions are the Harrison street school, San Francisco; Franklin high school, Los Angeles; Moneta avenue school, Los Angeles; Edmonds high school, near Seattle; Girls' parental school, Seattle; Sierra park school, Los Angeles; Sawtelle avenue school, Los Angeles; several commercial buildings; Mira Mar Hotel, Santa Monica; Ambassador Hotel, Los Angeles; Commercial Club, San Francisco; Farmers' and Merchants' Bank, Santa Paula.

The Wilson Folding Partitions have now been adopted as the standard partitions for all schools to be built in Los Angeles. The partition installed in the Franklin high school, Los Angeles, is 50' long and 20' high, each door weighs 700 pounds, which shows that there is no limit in width or height or weight to Wilson Folding Partitions.

Among the recent installations of Wilson Rolling Steel Doors are the Ambassador Hotel, Los Angeles; Pacific Spring Bed Company, Berkeley; O'Connor and Moffat, San Francisco; Southern Pacific roundhouse, Reno, Nevada; California Packing Corporation, San Francisco; Pacific Gas and Electric Company, Spring Gap Power House, Plumas County; Theo. F. Davies Company, Honolulu; Sperry Flour Company, Santa Barbara; Llewellyn Iron Works, Los Angeles; Pacific Mutual Life Insurance Company, Los Angeles; Grand Central Garage, Los Angeles; and many others.

The dominating feature of the Wilson Rolling Steel Doors is the heavy slat and grooves. The Wilson big-4 slat is the strongest and contains more steel per square foot than any other slat on the market. These slats are also electro-galvanized, which insures an even coating of galvanizing all over, so that there is no bridging or blisters which break in time and allow the slats to rust. Another feature is the easy raising and lowering of the Wilson Rolling Steel Doors, as the springs are of the very highest grade of tensile spring steel.

The J. G. Wilson Corporation has been in business 45 years and is known throughout the United States for its reliability and for the high standard products which it produces.

Powell and Post Streets Theatre

One of the largest building permits to be taken out this month in San Francisco was for the new Leow Theatre at Post and Powell streets. Mr. James Fitzhugh, owner, Messrs Reid Bros., architects, and Messrs. MacDonald and Kahn, builders. The cost was given at \$550,000.



Largest Elevated Water Tank in California

The inner surfaces of this tank, located at Merced, and the property of that city, are coated with

BITURINE ENAMEL

The outer tank surfaces and supporting structure are coated with

BITURINE SOLUTION

In San Francisco and Oakland over 200 Water Tanks have been treated with BITURINE.

Manufactured and Applied by

Hill, Hubbell & Co.

No. 1 Drumm Street,
SAN FRANCISCO

Los Angeles

Seattle

New York

When writing to Advertisers please mention this magazine.



DANGER!
UNTREATED
CONCRETE FLOORS

CONCRETE DUST WILL RUIN Your Clients' Machinery, Merchandise and Men

Architects and engineers have investigated Lapidolith, the liquid chemical dustproofer and hardener of concrete floors.

They know by experience that Lapidolith is needed to finish concrete—to complete the crystallization of the cement so that it shall hold the sand firmly imbedded and make the mass granite-like and serviceable, even under the abrasion of heavy trucking.

LAPIDOLITH

TRADE MARK

is readily flushed on new or old concrete floors. It is totally unlike integral hardeners or top dressings or paints because it chemicalizes—crystallizes the binding element, the cement and forms a new granite-hard material.

Cemcoat

the durable Mill White, Washable, of exceptional covering capacity, Gloss, Flat and Egg-shell, also all colors.

Lignophol

the modern wood preservative gives new life to old or new wooden floors.

With 30,000,000 square feet of concrete floors lapidolized in 1918 there is good reason for every architect and engineer specifying Lapidolith for every concrete floor job.

See page 340 in Sweet's Catalogue

Write for sample, testimonials and specification form.

L. Sonneborn Son, Inc.

Los Angeles
Portland

San Francisco
Seattle

General Contractors' Association, San Francisco

President, GEORGE WAGNER; First Vice-President, FELIX KAHN; Second Vice-President, H. H. HILP; Treasurer, W. C. DUNCAN; Secretary, E. T. THURSTON, Sharon Bldg.

Southern California Associated General Contractors

President, GODFREY EDWARDS; Vice-President, W. W. BRIER; Treasurer, J. F. HALL; Secretary, GEORGE A. ROGERS; and Assistant Secretary, B. READ, 430 Douglas Bldg., Los Angeles, Calif.

Contractors Convene

The joint session of the Associated General Contractors of the Pacific Northwest and Northwest Master Builders' Association was held at Spokane March 1, 2 and 3, Mr. J. M. Dougan, president of the Northwest Master Builders' Association, presiding. The attendance was large, enthusiasm pronounced and work accomplished of unusual importance.

After the preliminaries incident to the opening of the convention had been carried through, the chairman introduced Mr. James H. Ellison, of Minneapolis, representing Mr. W. O. Winston, president of the Associated General Contractors of America. Aside from delivering a prepared address, Mr. Ellison spoke extemporaneously on work of the organization throughout the country.

Ironing Out Cracks In Metal

CRACKS in metal pipe are now "ironed out" by a new process described in "The Scientific American" Supplement. As in the "ironing" of cloth, the process involves the application of heat and pressure at the same time and is a practical method of eliminating the results of so-called "fatigue". Metal affected by fatigue crystallizes, becoming brittle and breaking easily. The loss of time and money in the California oil-fields, where considerable pipe and other metal is ruined annually in this way, has led to the invention of the "ironing-out" method. Any source of heat may be used with the pressure, but electricity is said to be most satisfactory and efficient, although at the same time the most costly. Says the paper named above:

"Steel which has been subjected to repeated shocks will break easily, and the fractures show a crystalline appearance, due to repeated stresses which occur therein. . . . What happens is that as the steel is repeatedly stressed, either by bending, pulling, or twisting, it becomes fatigued. This fatigue is probably merely the first stages of an infinite number of small cracks or tears in the body of the steel, and these tears naturally tend to occur along the faces of the crystals of the material, at first of microscopic dimensions that do not materially weaken the metal. As they spread they greatly

RADIANT LIGHT

Increases
Illumination
Permanently

Eliminates
Glare and
Eyestrain

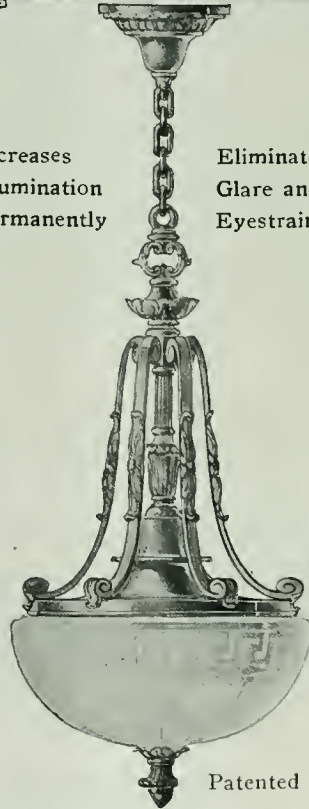

RADIANTLIGHT designs are developed to blend with any Architectural scheme. They range from pleasingly plain to the more ornate periods.

RADIANTLIGHT gives you 49 per cent more light on working surfaces than a bare lamp.

Enclosed and dust-proof. A permanent highly polished reflector inside the bowl and protected from dust. A reflector which is easily removed and cleaned. A reflector so focused as to direct the light to working plane, without glare. A reflector that directs the light rays as scientifically as the headlight of your automobile. No shadows, rings or spots of light on ceiling.

Demonstrations cheerfully given.

Ask your Contractor, Dealer or write.

Electric Appliance Company

807-809 MISSION STREET
San Francisco, Cal.

When writing to Advertisers please mention this magazine.



RESIDENCE OF MR. HARRY HILL, BROADWAY AND WEBSTER STREETS,
SAN FRANCISCO
KENNETH MACDONALD, Jr., Architect

Ruffled Brick

Shown in Exterior Panels

Manufactured by

Los Angeles Pressed Brick Co.

FROST BUILDING, LOS ANGELES



UNITED MATERIALS COMPANY

Distributors for Northern California
SHARON BUILDING, SAN FRANCISCO

weaken the metal, which eventually parts along the crystal faces, and the characteristic fracture, which is referred to as crystallizations, occurs.

"Before this state of fatigue continues sufficiently to weaken the metal materially, or, in other words, if it is taken in time, it can be partly arrested by heating the material to a welding heat. But the mere heating, while it tends to stop the cracks from spreading the while it may rearrange the crystals so that some of the cracks are partly closed, is of little value unless it is done early, and, in fact, before much of this tearing away of the metal occurs. A badly fatigued pipe can not be restored to its original strength by merely heating it.

"The Bardeen process not only heats the pipe, but also involves the application of longitudinal pressure. In the first place, during heating, the pipe has heavy spring pressure on its ends, so that there is a constant pressure of about 3,000 pounds on it in the direction of its length. As the pipe is heated to a carefully regulated temperature this pressure tends to squeeze the pipe together and to repair any small cracks.

"In the process electricity is used as the heating medium and, while somewhat expensive, is necessary for reasons which will be later pointed out. The first great advantage of the electric method is that each joint can be heated separately and the heat carefully controlled. In practice it requires something over fifteen minutes in which to heat a six-inch pipe twenty feet long, and during the heating the operator is able at all times to observe the pipe, which rests on a flat surface and is covered with a light asbestos hood. By heating it electrically and slowly the joint is very evenly heated throughout its length and has a chance to expand slowly.

"As soon as the pipe reaches a desired temperature the heating operation is shut off instantly. As during the heating operation the current actually flows through the pipe and the heat is generated in the body of the pipe, this heat is evenly generated throughout the body of the metal, and as all the losses are on the outer and inner surfaces, it follows that these surfaces are the cooler.

"Considering the pipe as a plate, it will be seen that the surfaces of the plate are cooler than the interior. It is highly probable that this unequal heating through the thickness of the material causes a working which helps to weld the cracks and arrest the fatigue. It is not this feature which makes the process a success, however, but the electromagnetic action which is taking place simultaneously.

"It is easy to calculate that the steel of the pipe is saturated with magnetism. It is, further, easy to calculate that the force exerted, which is in effect a squeezing of the pipe together, is in excess of three hundred pounds per square inch. In other

words, the magnetic pull in the body of the modern metallurgist responded to the need of huge quantities of cheap steel for bridges and ships, rails and boilers, of strong metals for axles and engines, of special alloys for electrical and domestic uses.

* * *

"The word metallurgy images to many minds a small, dark, smoky, smelly iron-foundry, or to others a high board fence surrounding furnaces glaring with white heat, and powerful machinery superhuman in power and dexterity. But in its entirety modern metallurgy influences our civilization down even to the commonest tools of life, and the initiated wonders to what state of savagery we would drop should it become a lost art."

Will Make Enamel Plumbing Fixtures

Mr. Fred Uecke, former factory manager of the Washington Iron Works of Los Angeles, California, has resigned his position to become identified with the newly organized All-In-One Company as production manager.

Mr. Uecke is now in the east and will visit all the modern plumbers' enamel ware factories, bringing west the new ideas of the east, which, in addition to the modern equipment to be installed in the All-In-One Company's plant, located at Slauson avenue and Downey Road, Los Angeles, will make it one of the most modern factories for the manufacture of plumbers' enamel ware in America.

It is the intention of the All-In-One Company to manufacture both new and old style fixtures, the new fixtures to contain the All-In-One features, which consist of an entire fixture finished in white enamel with hot and cold water inlets, waste and overflow integrals and bath cocks all cast with the tub or lavatory. It will eliminate the connecting joints of the old style fixture, facilitating installation and adding greatly to the beauty and utility of the fixture.

In All-In-One fixtures there is no metal work above the slab. This eliminates the care required to keep the ordinary metal parts clean.

The All-In-One lavatory has the additional feature of mixing the hot and cold water.

Apartment House

Messrs. Alfred W. Rea and Chas. E. Garstang, Trust & Savings building, Los Angeles, have prepared preliminary plans for a four-story brick apartment house to be erected at Fifth and Catalina streets, Los Angeles, for the Apartment-house Investment Co. The project will be financed by the sale of stock, the building to cost \$250,000.

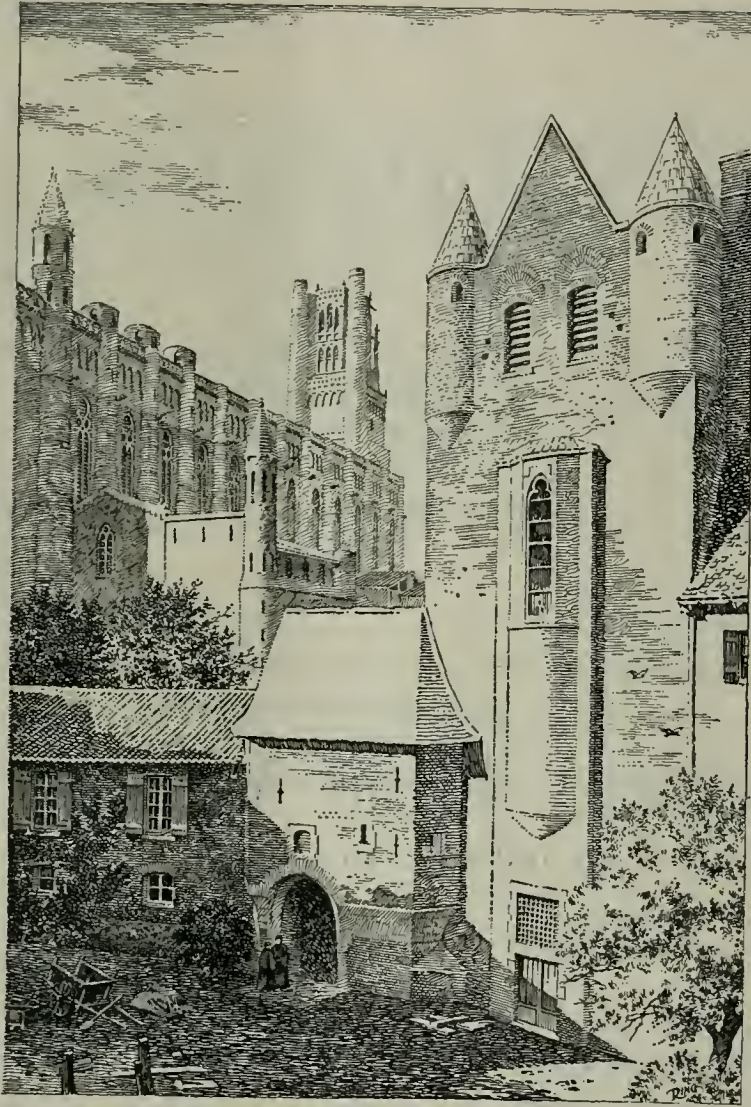

A. P. B. A.
USE FACE BRICK
— it Pays

*Western Tower from
Court of Palace,
Cathedral of
Sainte Cécile at Albi,
South of France.
Foundations laid 1282.
Consecrated 1480.
All exterior walls
of brick.*

THE brick craftsman long ago learned to make a durable building material. Judged from the centuries that many brick structures have stood, it is not an exaggeration to say that brick is practically indestructible.

With durability assured, American manufacturers are bending all their efforts toward extending the artistic possibilities of face brick,

and toward producing their wares more efficiently and economically. Their aim is constantly to produce a wider range of product at reasonable prices, in order that the architectural genius of the country may have a wider field for expression. Any member of this association is always ready to co-operate with the architect in solving his face brick problems.

AMERICAN FACE BRICK ASSOCIATION

1159 WESTMINSTER BUILDING • CHICAGO, ILLINOIS

THOMAS ROLPH

H. B. MILLS

ROLPH, MILLS & Co.

SAN FRANCISCO

SEATTLE

PORTLAND

LOS ANGELES

STRUCTURAL STEEL
 STEEL ROLLING DOORS
 GLASS *S* *S* *S*

Get Our Prices

149 CALIFORNIA STREET

Phone Sutter 1100

TiteSete Float Valve

For High and Low Pressures

IN SIZES UP TO 4 INCHES
 Larger Sizes on special order

Remains Wide Open
 until desired Water Level
 is reached then Closes
POSITIVELY without
 Water Hammer

Simple and Durable
 Positive and Reliable



Self-Cleaning,
 Non-Clogging
 By-Pass

NATIONAL VALVE COMPANY

Phone Douglas 5093

23-25 MINNA ST., SAN FRANCISCO

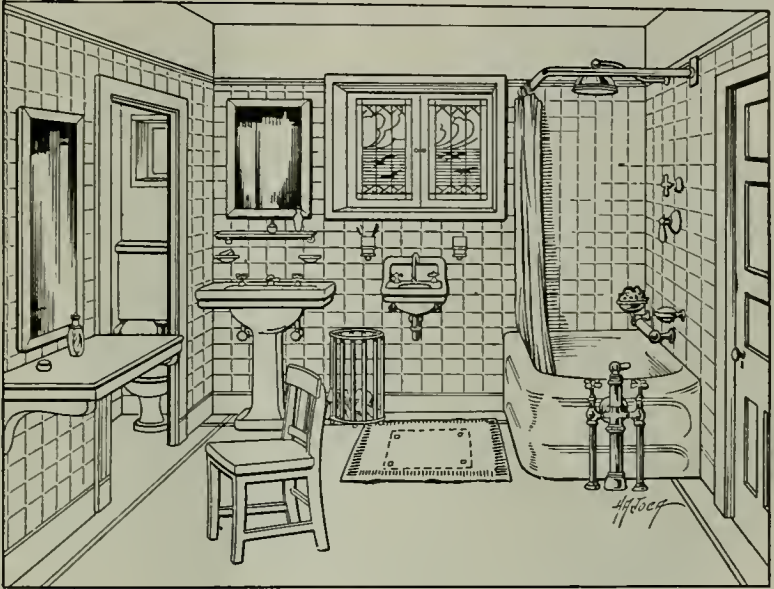

“HAJOCA”

luxuriously appointed bathroom

YOU want your new bathroom equipment to be as luxurious as the investment can command; but you want the right kind of luxury.

Hajoca fixtures are luxurious not alone in point of simple, substantial, artistic designs, but they embody the luxury of sanitary service—the most vital consideration for the health of the home.



HAINES, JONES & CADBURY Co.

MAKERS OF PLUMBING SUPPLIES

851-9 FOLSOM STREET, SAN FRANCISCO
PHILADELPHIA-NEW YORK-RICHMOND, VA.-SAVANNAH

IRON ^{AND} STEEL PRODUCTS

WAREHOUSE AND
MILL SHIPMENTS

STEEL BARS

for
CONCRETE
REINFORCING
FURNISHED AND
INSTALLED

EDW. L. SOULE' CO.
SAN FRANCISCO



SUTTER
2821



RIALTO
BUILDING

SERVICE

TESTING
INSPECTION
CONSULTATION
PRODUCTION

Structural and Engineering
Materials



Robert W. Hunt & Co.
Engineers

Chemical and Physical
Testing Laboratories

New York Chicago Pittsburgh
St. Louis San Francisco Mexico City
London Montreal

Heating and Ventilation

CONSULTING
Mechanical

ENGINEERS
Structural

Machine Design

Industrial Plant Design and
Equipment

569 Monadnock Bldg.
Phone Douglas 7019

San Francisco
California

Superintendent of Construction
Specifications and Estimates

JOHN E. HAMILTON

If a Manufacturer Uses This Label He Makes a Good Product

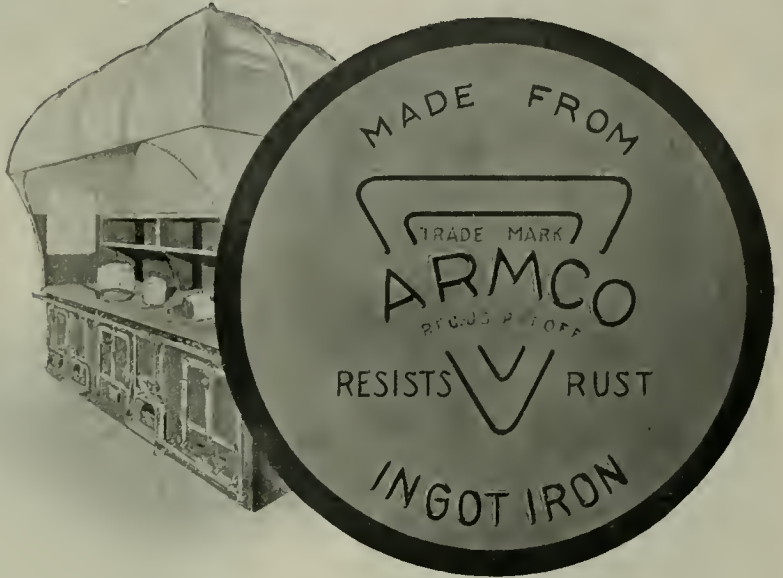

Coal and gasoline-gas range installed in Long Island residence of F. W. Woolworth. Made with "Armco" Ingot Iron by Bramhall, Deane Co., New York City.

NO manufacturer would use "Armco" Ingot Iron in a cheap, unworthy stove. If the blue and gold Armco triangle appears on any stove you buy—and it should—you may be sure that not only good materials but the best workmanship went into the making of it.

There is a surface difference between "Armco" Ingot Iron stoves and those made of ordinary sheet metal. The iron is smoother; the enameling takes a richer, more lustrous gloss; and there are no "pin-holes," bubbles, or other defects caused by impurities in the iron.

But the real value of "Armco" Ingot Iron is developed through long years of service.

Stoves do not wear out—they rust out. "Armco" Ingot Iron resists rust.

Another trouble with ordinary enameled iron is the tendency to crack and chip. With an "Armco" Ingot Iron base, enameling will survive ordinary usage for an indefinite period.

This iron is now being used extensively for stoves, enameled refrigerators, table tops, washing machines, and other household articles. When buying, ask the salesman to show you the Armco blue and gold triangle.

"Armco" Ingot Iron is used in the manufacture of such nationally advertised products as "Federal Washers," "Sanico Ranges," "Globe Stoves and Ranges," "Leonard Cleanable Refrigerators," "Buck's Stoves and Ranges," "Eden Washing Machines," "Brascolites," and "Novelty Pipeless Heaters."



THE AMERICAN ROLLING MILL COMPANY
Middletown, Ohio

Licensed Manufacturers under Patents granted to the International Metal Products Company

Pacific Coast Sales Office—Tenth and Bryant Streets, San Francisco; other Branch Offices in New York, Chicago, Pittsburgh, Cleveland, Detroit, St. Louis, Cincinnati, Atlanta, Washington, D. C., and Buffalo.

An ample stock of Armco Iron is carried at San Francisco Warehouse, Tenth and Bryant Streets.

**INCREASES PROFITS
FURNITURE SAVING**

U-TURN-IT

**SAVES MUCH SPACE
SELF VENTILATION**

Converts a 1-Room into A 4-Room Apartment

The Device is less than seven feet in diameter, seven feet six inches high, built of steel frame, and revolves on ball bearing floor ring; weighs, installed, 1500 pounds.



Combined View of Library and Kitchen.

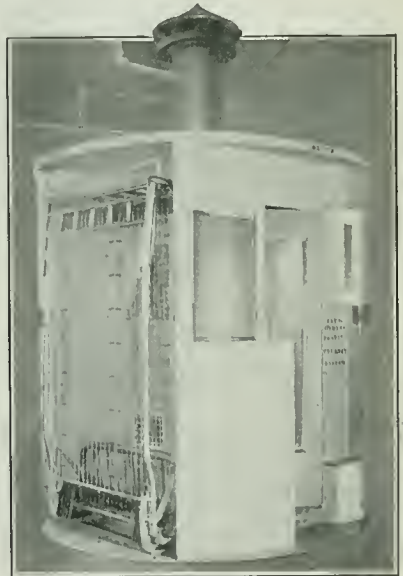

Bed and Dresser with Wardrobe.

Installed in new or old buildings, converts a one room into a four room apartment, containing conveniences of combination dresser, wardrobe and interior clothes closet; bed-room standard recess balanced lift bed, next to self ventilated ducts from the outer air when bed is in or out of use; library with writing desk, book cabinet and storage compartments; kitchen with complete plumbing, sink, hot and cold water, air tight revolving joints, designed to revolve with the U-Turn-It (approved by the Bureau of Plumbing Laws of the City of Buffalo, N. Y.) ice box and drain to sink, ironing board, china and kitchen utensil compartments; electrical, gas or oil hot plate stove, ventilated over head, and also garbage compartment with sanitary lining throughout.

Different types are made with two beds opposite for use in two or more rooms. Also types with kitchen omitted.

AGENTS WANTED IN PRINCIPAL COAST CITIES.

U-Turn-It Housekeeping System, Inc.

1202-1204 Claus Spreckels Building

SAN FRANCISCO, CALIFORNIA



HOW THIS LABEL protects YOUR BUSINESS

“Sterling” on silver, “Underwriters’ Label” on Safes.

Your only reason for buying a safe is to protect yourself against the loss of valuables, whether currency, jewels, business records or documents. Yet a superficial examination of any safe does not tell you how it would stand up in a withering fire, nor what would happen if it were caught under the crashing walls of a burning building.

It is this assurance that you get when you see the Underwriters’ Label on a GLOBE-WERNICKE SAFE. It is the guarantee of structural strength and performance awarded by the Underwriters’ Laboratory—an impartial body of engineers supported by the insurance companies.

In awarding the Globe-Wernicke Safe this guarantee label, the board of engineers subjected it to a more grilling test than would prevail in one out of a thousand fires. First they put the safe for an hour in a furnace fired to 1850 degrees;

extinguished the fire and left the safe there for another twenty-four hours. After repeating the ordeal, they dropped the red hot safe thirty feet onto a concrete sidewalk. Not until the safe had again been refired and cooled was the test completed. The safe was hardly scratched—and the contents, consisting of loose papers and books, were found in absolutely perfect condition.

“Such a safe,” said they, “is worthy of the Underwriters Label.”

In almost every business there are documents of such value and character that no insurance could compensate for their loss. Perhaps there are some papers of such extreme importance being held in your office tonight. Is it good business to compromise your firm on this sort of risk?

Ask the H. S. Crocker Company representative—phone or personal call—how the Underwriters’ Label on a GLOBE WERNICKE SAFE will protect your business.

H. S. CROCKER COMPANY, Inc.

565-571 Market Street, San Francisco

1444 Broadway
Oakland

Sacramento

Los Angeles

The Granite Work on Eldorado County Courthouse; National Bank of D. O. Mills, Sacramento;—
and Sen. Nixon Mausoleum, Reno, WAS FURNISHED BY

CALIFORNIA GRANITE COMPANY

Phone Sutter 2646

STONE CONTRACTORS

Builders' Exchange, San Francisco
Quarries, Rocklin and Porterville

Main Office, Rocklin, Placer Co., Cal.
Telephone Main 82

DUNN SPRAY METHOD OF PAINTING

Saves Time, Labor and Material. Will outwear paint applied by other methods.

→ RONFLE Special Paints for Specific Purposes Used Unless Otherwise Specified.

PACIFIC PAINTING AND ROOFING COMPANY

G. D. NEWTON, Manager

PACIFIC BLDG., SAN FRANCISCO. 388 - 12th St., OAKLAND

CHAS. STOCKHOLM & SONS

GENERAL CONTRACTORS

849 MONADNOCK BUILDING Phone DOUGLAS 4657 SAN FRANCISCO

M. E. RYAN

Electrical Contractor and Dealer

520 Clunie Building, San Francisco

Phone Garfield 3159

JOHN M. BARTLETT

GENERAL CONTRACTOR

Office
357 - 12th ST., OAKLAND

Phone Lakeside 6750
Res. Phone Berkeley 6884W

LARSEN-SAMPSON CO.

BUILDING CONSTRUCTION

Claus Spreckels Building

SAN FRANCISCO

Shop and Compare—that's the only true test
of values.

Furnishings for the home of distinctive style are
featured in this shop at prices that will bear the
strictest comparison.

Furniture Draperies Floor Coverings Interior Decorations

John Breuner & Co.
San Francisco

281 GEARY STREET

SAMSON SPOT SASH CORD

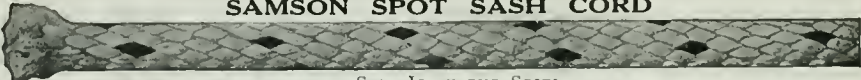

SPOT IT BY THE SPOTS

Made of extra quality cotton yarn, firmly braided and smoothly finished. Carefully inspected and
guaranteed free from all imperfections of braid and finish. → Can be distinguished at a glance
by our trade-mark, the Colored Spots. Send for catalogue and samples.

Pacific Coast Agent' JOHN T. ROWNTREE, Inc., San Francisco and Los Angeles, Cal.

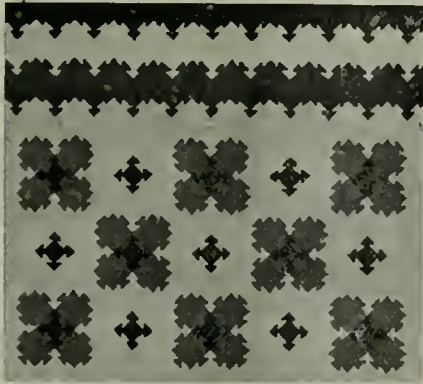

INTERLOCKING RUBBER TILING

material that is sure to give satisfaction. **Twenty tons installed in the Standard Oil Building, San Francisco.** Stock on hand for immediate delivery.

The Elevator Floor

whether in Office Building, Hotel or Department Store, is subjected to a great deal of wear and tear.

— SPECIFY —

INTERLOCKING RUBBER TILING

and you've provided your client's building with a Durable, Economical, Practical,



New York Belting and Packing Co.

NEW YORK

San Francisco Branch 519 MISSION ST. Phone Douglas 1837

Small booklet of designs mailed on request.

Look for this
Trademark



And if it's there don't worry any more about your Valves and Fittings



Specify and insist upon having

**The Kelly & Jones Co.
Valves and Fittings**

**Byers Genuine
Wrought Iron Pipe
Republic Steel Pipe**

Complete Line of Plumbing Supplies
Large Stocks for Prompt Delivery
Catalogue on request

California Steam & Plumbing Supply Co.

671-679 Fifth Street, Corner Bluxome
SAN FRANCISCO, CALIFORNIA

**FOR MODERN
STORE FRONTS**

Plummer's Disappearing Awnings

Are constructed with no outside attachments below awning recess. All mechanical parts entirely concealed. Send for Architects' Sheet showing specifications for recess construction, etc.

W. A. PLUMMER MFG. CO., 35-37 Front Street, San Francisco

JOHN TRAYNOR

CHARLES HARCOURT

OCEAN SHORE IRON WORKS

Manufacturers of Boilers, Steel Tanks, Steel Plate Specialties.
Dealers in Boilers, Tanks, Pumps, Engines, Machinery, Etc.

WE OFFER ESPECIALLY THE FOLLOWING, SUBJECT TO PRIOR SALE:

Two 80 HP Horizontal Tubular Boilers, 120 lbs. working pressure.
Two 100 HP Heine Safety Water Tube Boilers, 130 lbs. working pressure.
Ten 250 HP Marine Heine Water Tube Boilers, 175 lbs. working pressure.

PRICES ON APPLICATION — SEND US YOUR INQUIRIES

Office and Works:
550-558 EIGHTH STREET

Telephone Market 462
SAN FRANCISCO, CAL



Model No. 7A.

NO GERMS HERE

HAWS IMPROVED SANITARY DRINKING FAUCET eliminates all possibility of contracting disease from dirty bulbs or unsanitary bowls. Provided with an overhead cowl, the drinker's lips never touch the source of supply. A slanting stream throws the water from right to left and away from the bubbler, instead of straight up to fall back over the fountain head. Recommended for Schools and Public Playgrounds. A type used extensively by the U. S. Government. Manufactured by

Haws Sanitary Drinking Faucet Co., Inc.
1808 Harmon Street, Berkeley Phone Piedmont 3742

GENUINE PRESERVATIVE PAINT FOR EVERY USE

Moran's Patented Preservative Paints and Compounds

will positively preserve iron, steel, concrete, roofs, piles, poles, railroad ties, and all wood or metal surfaces above or below earth or water.

MORAN'S PATENTED ANTI-FOULING AND HULL PAINT

Quality Products proven by the test of time

COMMERCIAL EXPORT & IMPORT CO., Inc.

SOLE REPRESENTATIVES

BALBOA BLDG., San Francisco. Tel. Sutter 6833

Branches in Los Angeles, Salt Lake City, Pittsburgh, Honolulu, Australia, New Zealand

When writing to Advertisers please mention this magazine.

GENERAL BOILERS COMPANY

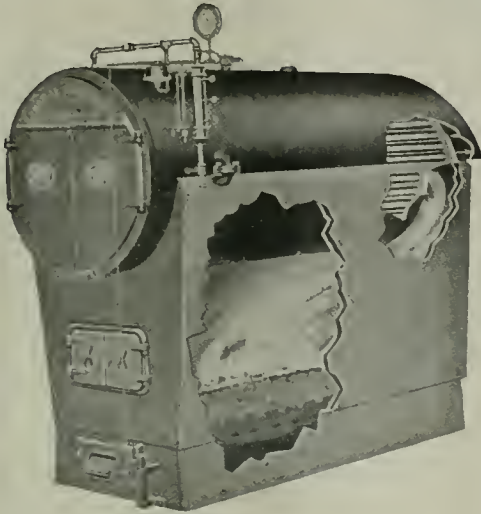

General Office and Plant:
WAUKEGAN, ILLS.

Manufacturers of
“PACIFIC”

**STEEL HEATING BOILERS
AND
CIRCULATING TANKS**

DEPARTMENT OF SALES:
322 MONADNOCK BUILDING, SAN FRANCISCO. Telephone Sutter 4665

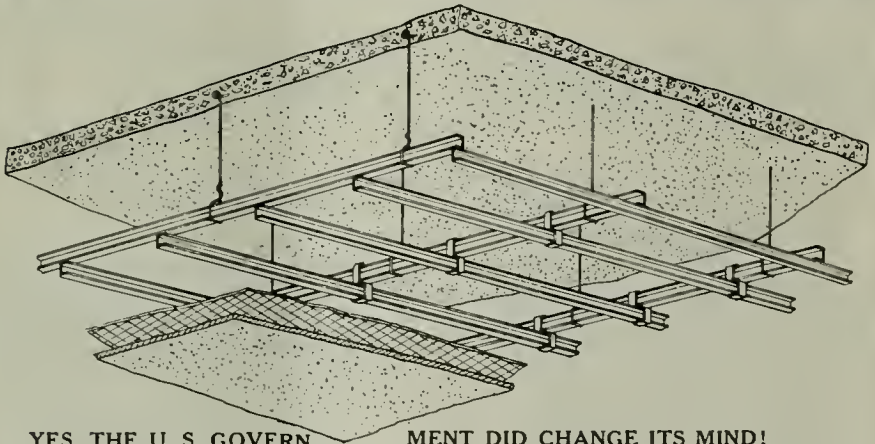

YES, THE U. S. GOVERNMENT DID CHANGE ITS MIND!

The specifications on the U. S. Government Building at Portland, Oregon, called for the tying together of the carrying bar and lathing bar with wire.

We submitted our system, and after an explanation of the S. S. System for fastening bars, the engineers and government officials were convinced that here, at last, is the perfect and economical system, and these reasons added weight in deciding.

It is a positive tie, no slipping or shearing.

It is strong, Smith Emery test to 353 lbs. before failing.

It is fast, can be applied on the bench or on the scaffold.

Made for 1 inch carrying bar and $\frac{3}{4}$ inch lathing bar and $\frac{3}{4}$ inch carrying bar and $\frac{3}{4}$ inch lathing bar. Can be used for wall furring as well as for ceiling work.

THE STEEL STUDDING COMPANY

Also Manufacturers of

THE PRONG CHANNEL FOR SOLID AND HOLLOW PARTITIONS

Agents Wanted Everywhere

1216 Folsom Street, San Francisco

THE TORMEY CO.

Phone Franklin
5-5-9-8

1042 Larkin St., San Francisco, Cal.

Alvaline, Cementoline

and other

Jones-Duncan Products

MAGNER BROTHERS

PAINT MAKERS

Telephone: Market 113
414-424 Ninth St. San Francisco

HEATING=PLUMBING

COMPLETE PLUMBING AND
HEATING SYSTEMS INSTALLED
IN ALL CLASSES OF BUILDINGS
ALSO POWER PLANTS

GILLEY-SCHMID CO., Inc.

198 OTIS STREET, SAN FRANCISCO.
Tel. MARKET 965

"BLAZING" THE TRAIL

We've been doing it for many years—giving the Sportsman Better Value for Quality than he ever before received. "Value at a Fair Price" in everything for the Sportsman.



583-85 MARKET ST.
SAN FRANCISCO, CAL.

SEND FOR CATALOG *The Sign of Quality*

Phone Douglas 3224

**Hunter & Hudson
ENGINEERS**

Designers of Heating, Ventilating
and Wiring Systems. Mechanical
and Electrical Equipment of
Buildings.

703 Rialto Bldg., San Francisco, Cal.

**BEAVER BLACKBOARD
BEAVER GREENBOARD**

SCHOOL FURNITURE
AND SUPPLIES—
OFFICE, BANK AND
COURTHOUSE FURNITURE—
THEATRE AND
AUDITORIUM SEATING

Rucker-Fuller Desk Co.

677 Mission St., SAN FRANCISCO, CAL.
434 Higgins Bldg., LOS ANGELES, CAL.
432 - 14th Street - OAKLAND, CAL.

NATIONAL ROOFING COMPANY
J. F. ELLIS

PACIFIC ROOFING COMPANY
J. B. McKEON

C. G. WILLIAMS

A. K. GOODMUNDSON

Members of

Builders and Roofers Exchange

2140 San Pablo Avenue, OAKLAND
Lakeside 271

RUSSWIN

BUILDERS' HARDWARE

JOOST BROS., Inc.

SAN FRANCISCO AGENTS.

We Carry Complete Stock:
Fishing Tackle—Guns—Mechanics' Tools—
Paints—Crackery and Glassware—Stoves—
Household Goods. Telephone Market 891.

NO BRANCH STORE

Mazda Lamps Electric Goods

Oakland 540

The Largest Exclusive Electrical House in the State

MOTORS

BOUGHT — SOLD
RENTED—REPAIRED

Lighting Fixtures

Manufactured

Construction

MAINTENANCE
SUPPLIES

Estimates and engineering data cheerfully furnished

SPOTT ELECTRICAL CO.

Yours for Service

16th & CLAY STREETS

OAKLAND, CALIFORNIA

PORTAL Economy Plan Service and PORTAL Quality Wall Beds

PORTAL wall-beds have received Highest Award wherever exhibited—an evidence of quality that should interest the Builder.

Patented oscillating arm permits the "Portal" bed to revolve in a foot less space than any other revolving bed—a good point to remember.



When writing to Advertisers please mention this magazine.

A. D. COLLMAN

P. F. SPEIDEL

COLLMAN AND SPEIDELGENERAL
CONTRACTINGCONSTRUCTION
ENGINEERS

Telephone SUTTER 4858

MONADNOCK BUILDING, SAN FRANCISCO

I. R. KISSEL

Phone Franklin 548

Decorator, Painter and Paperhanger

1747 SACRAMENTO ST., Bet. Polk St. and Van Ness Ave., SAN FRANCISCO

ROBERT TROST

PHONE MISSION 2209

General Building ContractorWe Specialize in High Grade Work and Employ Skilled
Labor in every Branch of the Building Industry.26th and Howard Streets
SAN FRANCISCO

P. A. Palmer

Peter Petersen

W. L. Kelly

PALMER & PETERSEN**Contracting Engineers**

782-796 Monadnock Building

SAN FRANCISCO, CAL.

S. RASORI

Res. 2042 Taylor Street
Phone Franklin 6258

J. DEL FAVERO

Res. 2358 Jones Street
Phone Franklin 9524**DEL FAVERO & RASORI**

GENERAL CONTRACTORS

Phone Sutter 6700

Office: 180 JESSIE STREET, San Francisco, Cal.

MONSON BROS.

Building Construction

Yard
Mariposa and Bryant Streets
Phone Market 2693251 Kearny Street, San Francisco
Phone Douglas 6619**UNIT CONSTRUCTION COMPANY**

(INCORPORATED)

ENGINEERING AND CONSTRUCTION

Telephone Kearny 28

429-36 Phelan Building, SAN FRANCISCO

J. D. HANNAH

Contractor and Builder

OFFICE: 142 Sansome Street
San Francisco, Cal.

Telephone Douglas 3895

BUILDERS EXCHANGE, 180 JESSIE STREET

**MOUNT DIABLO CEMENT
COWELL SANTA CRUZ LIME**

ALL KINDS OF

BUILDING MATERIALS

HENRY COWELL LIME AND CEMENT CO.

Phone Kearny 2095

No. 2 MARKET STREET, SAN FRANCISCO

Automatic Fire Sprinklers

Protect your building and business from destruction by fire and reduce your Insurance Rate.

Pacific Fire Extinguisher Co.

FIRE PROTECTION ENGINEERS

424-440 HOWARD STREET
SAN FRANCISCO

MANUFACTURING PLANT
272 STEUART STREET

ARCHITECTS - BUILDERS - CONTRACTORS

MODERN CONDITIONS practically DEMAND gas heating. Be fore-handed and include provision for the use of GAS HEATING APPLIANCES in your plans and construction program. If an estimate on a complete heating system will help, do not hesitate to call on us.

Pacific Gas and Electric Company

Kawneer

Factory
Berkeley, Calif.
Berkeley 8710

MANUFACTURING COMPANY
of California

San Francisco Office:
180 Jessie Street
Sutter 6700



Kawneer
Store-Fronts
All Metal Mouldings

Kawneer
Simplex Windows
Weightless & Reversible

I. M. SOMMER & CO.ENGINEERS AND
GENERAL CONTRACTORSCONCRETE
CONSTRUCTION

Phone Kearny 4582

401 BALBOA BLDG., SAN FRANCISCO

K. E. PARKER COMPANY, Inc.

GENERAL CONTRACTORS

Phone Sutter 5661

Room 515 Clunie Building, SAN FRANCISCO

**R. W. LITTLEFIELD
BUILDING CONSTRUCTION**

357 12th Street, Room 9, Oakland, Cal.

Phone Lakeside 6750

H. H. HILP, Jr.

J. FRANK BARRETT

BARRETT & HILPCONCRETE CONSTRUCTION BUILDERS GENERAL CONTRACTORS

SHARON BUILDING, SAN FRANCISCO

TELEPHONE SUTTER 1168 or 1169

Phone Sutter 663

**BOXTON & ZWIEG
General Contractors**

FLATIRON BUILDING

SAN FRANCISCO

STEELFORMS Signify ECONOMY, RAPIDITY, and EFFICIENCY

STEELFORM CONTRACTING COMPANYSTEELFORMS FOR
CONCRETE
BUILDINGSC. B. Hopkins, C. E., Manager
681 Market Street, San FranciscoCONCRETE JOIST
FLOOR
CONSTRUCTION**W. C. DUNCAN & CO.**

205 Sharon Bldg.

General Contractors

San Francisco

Telephone Kearny 772

M. E. VUKICEVICH

SPENCER B. BAGGE

**VUKICEVICH & BAGGE
GENERAL CONTRACTORS**

Phone Sutter 6700

Office, Builders Exchange, 180 Jessie St., San Francisco

245 Market St.
S. F. Kearny 2028

Standard Fence Co.

310 Twelfth St.
Oakland 475

WIRE AND IRON WORKS

DESIGNERS - BUILDERS
FACTORY PROTECTION FENCE
AVIARY AND TENNIS COURT FENCE
320 North Los Angeles Street, Los Angeles, Cal. Phone 67188

WIRE GRILL WORK—WIRE SCREEN
FLEXIBLE WIRE CONVEYOR BELT
WIRE SPECIALTIES

Steel Bars

FOR CONCRETE REINFORCEMENT

Cut to Length, Fabricated, Installed

BADT-FALK & CO.

Tel. Douglas 3466

346 Call-Post Bldg., 74 New Montgomery St., San Francisco

' WORK THAT SATISFIES "

ATHERLEY BROS.

PAINTING AND DECORATING
WINDOW SHADES MADE TO ORDER

2032 Polk Street, San Francisco
Phone Prospect 83

MARTEN & FREDERICK

Phone FRANKLIN 689

UNITED WORK SHOPS

Designers, Makers and Contractors of Fine Furniture, Draperies and Complete Interiors.

1374 SUTTER ST., SAN FRANCISCO

ABEEL-JENSEN COMPANY

Manufacturers' Representatives

MONARCH METAL PRODUCTS CO.
VONNEGUT HARDWARE CO.

UNIVERSAL WINDOW CO.
HUGHES-EVANS CO., INC.

Call Building, San Francisco

Res. Tel. Merritt 3600

HERBERT BECKWITH

Building Construction

Formerly with
ARTHUR ARLETT

323 Newton Ave.
Oakland

D. ZELINSKY & SONS

PAINTERS AND DECORATORS

420 TURK STREET,

SAN FRANCISCO

CHARLES T. PHILLIPS

• CONSULTING ENGINEER •

PACIFIC BUILDING SAN FRANCISCO
HEATING VENTILATION WIRING ILLUMINATION

Ideal Air-Washers. Ideal Fruit-Dryers. Fan Systems for Heating, Cooling and Drying.

Ideal Heating and Engineering Co.

Air-Conditioning, Heating, Cooling and Drying

192 ERIE STREET

Phone Market 3708

SAN FRANCISCO

Atlas Heating and Ventilating Co., Inc.

ENGINEERS and CONTRACTORS

STEAM AND HOT WATER HEATING, FANS, BLOWERS,
FURNACES, POWER PLANTS--SHEET METAL WORK

Phone Douglas 378

Fourth and Freelon Sts., Bef. Bryant & Brannan, SAN FRANCISCO

Illinois Automatic Vacuum and Vapor Systems of Heating

"TWENTY-FIVE YEARS OF QUALITY"

ILLINOIS ENGINEERING COMPANY

JAS. I. KRUEGER, *Representative*

Pacific Building, San Francisco

Telephone: Sutter 7057

HEATING
VENTILATION

FLOOR AND WALL TILING

PLUMBING
SHEET METAL WORK

SCOTT CO., Inc.

SUCCESSOR TO JOHN G. SUTTON CO.

243 MINNA STREET

SAN FRANCISCO

ALEX COLEMAN

CONTRACTING PLUMBER

706 ELLIS ST., SAN FRANCISCO

Phone FRANKLIN 1006

WM. F. WILSON COMPANY

MODERN SANITARY APPLIANCES

Special Systems of Plumbing for Residences, Hotels, Schools, Colleges, Office Buildings, Etc.

Phone Sutter 357

328-330 Mason Street, San Francisco.

C. DRUCKER

J. C. JAMES

JAMES & DRUCKER

Plumbing—Heating Contractors

Phone Market 275

450 Hayes Street, San Francisco, Cal.

LANNOM BROTHERS MFG. CO.

Hardwood Interior
Finish a Specialty

MILL WORK, SASH and DOORS

Veneered Doors
and Panels

Telephone Oakland 241

Fifth and Magnolia Sts., Oakland

GOODS OF QUALITY

A new syphon action closet at a moderate price that is not only ultra-efficient but pleasing in appearance and combining many new sanitary features.

On display at our show room—

64 Sutter Street, San Francisco

Main office and warehouse: Sixth, Townsend & Bluxome Sts.



Holbrook, Merrill & Stetson

Designers - Fabricators - Erectors

General Plate Work



Hydro - Pneumatic Pressure Tanks —
Hemispherical Bottom Tanks and Towers
— Oil and Water Tanks — Oil Stills —
Pipe Lines—Smoke Stacks—Well Casing
— Rock Screens — "Western" Corrugated
Culvert Pipe.

Western Pipe and Steel Company

OF CALIFORNIA

444 MARKET STREET
SAN FRANCISCO

1758 NORTH BROADWAY
LOS ANGELES



CEMENT GUN

Will Make Your Concrete Waterproof

Cement Gun Construction Company

of California
701 Balboa Building,
San Francisco

For
DAMS
RESERVOIRS
TUNNELS
BULKHEADS
CANAL LININGS
CEMENT FLUMES
use the
Cement Gun
—
SPEED
ECONOMY
PERMANENCE



LIGHT WEIGHT
FIREPROOF
EVERLASTING

STONE SHINGLES

VARIETY
and
DURABILITY
of COLORS

**McCLENAHAN
PRODUCTS
COMPANY**

112 Kearny St.

INC.

San Francisco

QUEBRACHO!

One coat Argentine Quebracho paint on steel will outwear three of red lead and graphite at fraction of cost. Contains South American gum that gives great tenacity. Ask about records on steel; also for damp-proofing concrete and for protecting piling from teredoes.

IMP MANUFACTURING CO.

732 Second St., Oakland Phone Lakeside 478

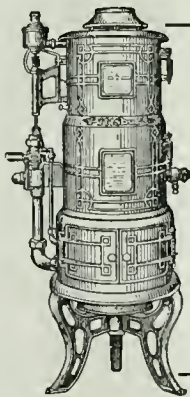

Pittsburg

It Insures
Instant
Hot Water
Service

**PITTSBURG WATER
HEATER COMPANY**

478 Sutter St., San Francisco
Phone Sutter 5025

**BUSINESS • SYSTEMS
OFFICE • FURNITURE**



JW Wentworth

539 MARKET ST., SAN FRANCISCO
DISTRIBUTORS FOR SALES ROOMS IN OAKLAND
LIBRARY BUREAU LOS ANGELES SEATTLE

WIRING



185 Stevenson Street, San Francisco
Phone Douglas 4832

NATIONAL WINDOW SHADE COMPANY, Inc.



Agents for
BRENLIN
The Long Wearing
Window Shade
Material

National Shades wear
twice as long as the
ordinary kind

Phone Franklin 552

244 EDDY STREET, SAN FRANCISCO, CAL.

Who Cleans Brick?

Who cleans brick walls and who cleans old or loose brick?

Replies from twenty-six cities, received by the A. G. C. Bulletin, tabulated in two columns below, indicate that the cleaning of old brick is always done by laborers, while on wall cleaning in eight cities bricklayers are usually employed; in six laborers do the work, and in twelve no report was made.

City	Cleaning walls done by	Cleaning old brick done by
Baltimore.....	bricklayers	laborers
Birmingham.....	laborers (no pointing)	"
Boise.....	?	"
Boston.....	bricklayers	"
Chicago.....	?	"
Cincinnati.....	bricklayers (often by laborers)	"
Cleveland.....	bricklayers	"
Dallas.....	bricklayers	"
Des Moines.....	bricklayers	"
Detroit.....	laborers unless sublet to "truck pointers"	"
Kansas City.....	bricklayers and non-uniform "cleaners"	"
Los Angeles.....	laborers	"
Louisville.....	?	"
Milwaukee.....	?	"
Nashville.....	?	"
New Orleans.....	bricklayers and special laborers	"
Philadelphia.....	?	"
Richmond.....	?	"
San Antonio.....	?	"
San Francisco.....	?	"
Savannah.....	?	"
South Bend.....	?	"
St. Joseph.....	?	"
St. Louis.....	?	"

Office Phone
West 2429

Residence Phone
Fillmore 1856

J. F. Wayne & Co.

Interior Decorating

1914 FILLMORE STREET
SAN FRANCISCO

Tacoma..... laborers
Toledo..... machine and laborers

New Pamphlet on Concrete Waterproofing

The Truscon Laboratories, Detroit, has issued a new technical pamphlet (Number 8) on "The Waterproofing of Concrete," a subject on which there is not an over-abundance of information to be found in textbooks. The need of a text on the fundamentals of this important subject is outlined.

The pamphlet will be sent complimentary to any architect, engineer or builder requesting same.

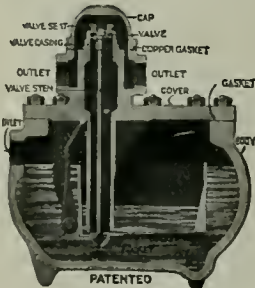

GENUINE SQUIRES STEAM TRAPS

Great Durability and High Efficiency.
Main joints above water line.
Valve and Seat accessible without breaking joints.
Every Trap unconditionally guaranteed.

W. E. MUSHET CO

SOLE AGENTS

Phone Sutter 4797



502 Mission Street
San Francisco, Cal.



POSITIVE ELECTRIC INTERLOCK

(BAR LOCK TYPE)

Prevents Elevator Accidents Occurring at the Entrance Door

Approved by National Underwriters Laboratories—Meets requirements of Elevator Safety Orders of Industrial Accident Commission, State of California

ELEVATOR SUPPLIES COMPANY, Inc. 186 FIFTH STREET,
SAN FRANCISCO

Capital \$1,000,000

CALIFORNIA DEPARTMENT

Surplus \$1,122,000

THE FIDELITY AND CASUALTY COMPANY OF NEW YORK

Prompt Service for

BONDS AND CASUALTY INSURANCE

203-206 Merchants Exchange Building

SAN FRANCISCO, CAL.

ANY PLACE ANY TIME PROMPTLY "We Serve You"

JOHN H. ROBERTSON

Successor to Robertson & Hall

GENERAL INSURANCE

Phone Sutter 2750

621 First National Bank Building, San Francisco

PACIFIC DEPARTMENT

Globe Indemnity Company

BONDS and CASUALTY INSURANCE for CONTRACTORS

FRANK M. HALL, formerly Robertson & Hall, Mgr.

120 Leldesdorff Street Phone Sutter 2280 SAN FRANCISCO

National Surety Company of New York

The World's Largest Surety Company

Assets over \$20,000,000

Pacific Coast Department: 105 MONTGOMERY ST., SAN FRANCISCO, CAL.

Frank L. Gilbert, Vice-President

Phone, Sutter 2636

School and Theatre

STAGES AND EQUIPMENT

EDWIN H. FLAGG

SCENIC COMPANY, Inc.
400 Pantages Bldg., San Francisco, Cal.
1638 Long Beach Ave., Los Angeles, Cal.

PHONE DOUGLAS 2370

R. McLERAN & CO.

GENERAL CONTRACTORS

HEARST BUILDING

SAN FRANCISCO, CAL.

L. J. RUEGG

J. B. RUEGG

RUEGG BROS.

CONTRACTORS AND BUILDERS

Phone Douglas 1599

719 Pacific Building, SAN FRANCISCO

OPEN HEARTH

Reinforcing Steel Bars



Square Deformed — Immediate Shipment — Cut to required lengths

PACIFIC COAST STEEL COMPANYSales Office, Rialto Building. **SAN FRANCISCO.** Phone Sutter 1564

Architects and Building Contractors!

The HICKS-JUDD COMPANY, Inc., and SUNSET PUBLISHING HOUSE
have consolidated under the name of
ABBOTT-BRADY PRINTING CORPORATION
460 Fourth Street, San Francisco, Calif.

THE Binding of Magazines and Periodicals
will continue as one of Our Specialties;
also Expert Plate and Map Mounting.

Reprinting of The Architect and Engineer Advertisements for Circular or File Use

George S. MacGruer }
Robert M. Simpson } Members of Builders Exchange

MacGruer & Simpson

CONTRACTING PLASTERERS

PLAIN AND ORNAMENTAL

Cement, Stucco and Artificial Stone

Phone Sutter 5688

540 Call-Post Building, San Francisco

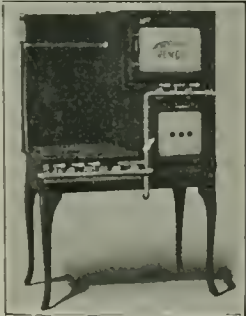

Detroit Jewel Gas Ranges

FOR HOME, RESTAURANT, HOTEL AND CLUB

We carry a Full Line of Stock Sizes

SELLING AGENTS

NATHAN DOHRMANN CO.

Geary and Stockton Streets, San Francisco

PARMELEE-DOHRMANN CO.

436-444 S. BROADWAY, LOS ANGELES

When writing to Advertisers please mention this magazine.

CALIFORNIA ARTISTIC METAL & WIRE CO.
 J. T. McCORMICK, PRESIDENT
 ORNAMENTAL IRON AND BRONZE
 349-365 SEVENTH ST. SAN FRANCISCO

MORTENSON CONSTRUCTION CO.
 CONTRACTORS FOR STRUCTURAL STEEL AND IRON
 H. MORTENSON, PRES. CHAS. G. MORTENSON, VICE-PRES. AND MGR.
 OFFICE AND SHOPS: CORNER 19TH AND INDIANA STREETS
 PHONE: MISSION 5033 SAN FRANCISCO, CAL.

RAYMOND GRANITE COMPANY, Inc.
 Owning and operating at Knowles, Madera County, the largest Quarry in the world
 CONTRACTORS FOR STONE WORK
 Designers and Manufacturers of Exclusive Monuments and Mausoleums
 Main Office and Yard: No. 1 and 3 Potrero Avenue, San Francisco, California
 Also at 1350-Palmetto Street, Los Angeles

CAEN STONE  **A. KNOWLES**
 A refined, elegant, interior finish. CONTRACTOR and PLASTERER
 442 Call-Post Building San Francisco

ZOURI SAFETY SASH BARS
 Accepted by the Insurance Underwriters for Safety Setting of Plate Glass used in Store Front Construction.
COBBLEDICK-KIBBE GLASS CO.
 175 JESSIE ST. WASHINGTON AT THIRD ST.
 SAN FRANCISCO, CAL. OAKLAND, CAL.

Telephone Mission 58 A. A. Devoto, President
CENTRAL IRON WORKS, Inc.
 STRUCTURAL STEEL
 Office 2050 BRYANT STREET SAN FRANCISCO, CAL.

JOHNS-MANVILLE
 SERVES IN CONSERVATION
 Through
ASBESTOS and its ALLIED PRODUCTS

 **SCHRADER IRON WORKS, Inc.**
 STRUCTURAL STEEL CONTRACTORS
 Fire Escapes, Waterproof Trap Doors, Ornamental Iron Work
 1247-1249 HARRISON STREET SAN FRANCISCO, CAL.
 Bet. 8th and 9th Telephone Market 337

THE HYLOPLATE BLACKBOARD

SCHOOL FURNITURE
AUDITORIUM SEATING

MAPS
GLOBES
ATLASES

C. F. WEBER & CO.

985 Market Street
SAN FRANCISCO

222-224

S. Los Angeles St.
LOS ANGELES

100 W. Commercial
Row, RENO, NEV.

524 W. Washington
Street, PHOENIX, ARIZ.



SCHROEDER DIRECT-FLUSH VALVES

for
toilets

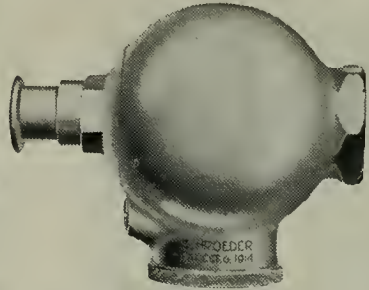

THE SCHROEDER'S CORRECT— ITS FLUSH IS DIRECT

ELIMINATES: Repair Bills
Corrosion
Rubber or Leather parts
By-Passes
Water Waste
Hammering

An efficient, economical and simply constructed
Flush Valve made by a California manufacturer.

Write for descriptive booklet.

The New Stock Exchange Building (Morgan, Walls & Morgan, architects), on Spring Street, between 6th and 7th Streets, Los Angeles (a 13-story office building of the very latest type) is equipped throughout with Schroeder Valves.

MADE BY
STANDARD METALS MANUFACTURING CO.
1300-1302 N. Main St.—Los Angeles, Calif.
Phone 66864



Formal Garden Effects

may be obtained on your Country
Estate within a period of two or
three years.

MacRORIE-McLAREN CO.

141 Powell Street, San Francisco
Telephone Douglas 4442

THE HEART OF A BUILDING IS ITS PIPING EQUIPMENT

A complete line for the Piping Features of Buildings—Power, Plumbing, Heating, Ventilating, Refrigerating, Vacuum-Cleaning, Gas, Water, etc.—is furnished by Crane Co. through the Plumbing and Heating trade.

The Architect, Engineer and Builder, or Investor, may enjoy, through the facilities of this Company, the distinct advantage of dealing entirely with one Competent and Responsible House.

Exhibit Rooms, Offices and Warehouses in San Francisco and Oakland and Fifty-one other cities.

CRANE CO.

1855—1918



VALVES AND
FITTINGS





Western Safety Man'fg. Co. Inc.
Formerly
MEYERS ELECTRIC SAFETY SWITCH CO., Inc.
Manufacturers of
Enclosed Externally Operated Safety
Switches, Knife Switches, Metal Switch
and Cut Out Boxes, Safety Switch Boards
Office, 247 Minna Street SAN FRANCISCO
Telephone, Sutter 3008

"TYPE C"

Telephone
DOUGLAS
2046

Butte Electrical Equipment Company
BEECO
TRADE MARK-REG

530
FOLSOM
STREET

**CONTRACTORS FOR POWER LIGHTING
AND INDUSTRIAL INSTALLATIONS**

For the convenience and guidance of our customers,
we have adopted BEECO as our trade name.

SAFETY ELECTRIC COMPANY
MANUFACTURERS OF

SWITCHBOARDS
SAFETY SWITCHES
SAFETY CONTROLS



PANEL BOARDS
SAFETY PANELS
KNIFE SWITCHES

59-65 Columbia Square San Francisco, Calif.
Telephone Market 2949

L. SIEBERT J. GENSLER

Drendell Electrical & Mfg. Co.
Incorporated
SWITCHBOARDS, PANEL BOARDS, KNIFE SWITCHES,
CABINETS, THEATRE INSTALLATIONS,
PROTECTIVE POWER PANELS
1345-1353 Howard St., San Francisco Telephone Market 1753

BUTTE ELECTRIC & MFG. CO. DOUGLAS 145**ELECTRIC BANK PROTECTION SYSTEMS****WIRING FOR BUILDINGS**534 FOLSOM ST.
SAN FRANCISCO**H. S. TITTLE****CONTRACTING ELECTRICAL ENGINEER**

766 FOLSOM ST., SAN FRANCISCO

Phone SUTTER 4278

**To Be "Low Bidder" Not Always Our Aim.**Our most particular attention is given to prompt and skillful handling of all electrical work of any nature with "QUALITY AND SERVICE GUARANTEED."
Our nation-wide organization and large experience in this field assures you always of fair estimates and absolute satisfaction.**F. E. NEWBERY ELECTRIC CO.**

163 Sutter St. (413 Lick Bldg.) San Francisco, Phone Sutter 521

San Francisco, Cal.

Oakland, Cal.

Los Angeles, Cal.

NEPAGE, McKENNY CO.*Electrical Engineers and Contractors*

Phone Sutter 2369

589 Howard St., San Francisco, Cal.

Phone Market 2541

M. FLATLAND

GLOBE ELECTRIC WORKS

Estimates Furnished on Everything Electrical

ELECTRIC SUPPLIES

1959 Mission Street, bet. 15th and 16th

SAN FRANCISCO

**Browne-Langlais Electrical Construction Co.**

Agents for

ROBBINS and MYERS MOTORS **PACKARD MAZDA LAMPS**

213 MINNA STREET, SAN FRANCISCO

Telephone Douglas 976

G. WALTER SPENCER, Manager

Phone Lakeside 6750

SPENCER ELECTRIC CO.**CONTRACTING AND ENGINEERING**

355 TWELFTH STREET

OAKLAND, CALIF.

CHAS. G. FRIES.

TELEPHONE SUTTER 5706

VICTOR A. KUEHN

LIBERTY ELECTRIC COMPANY479 Sutter St. **Electrical Contractors** San Francisco, Cal.

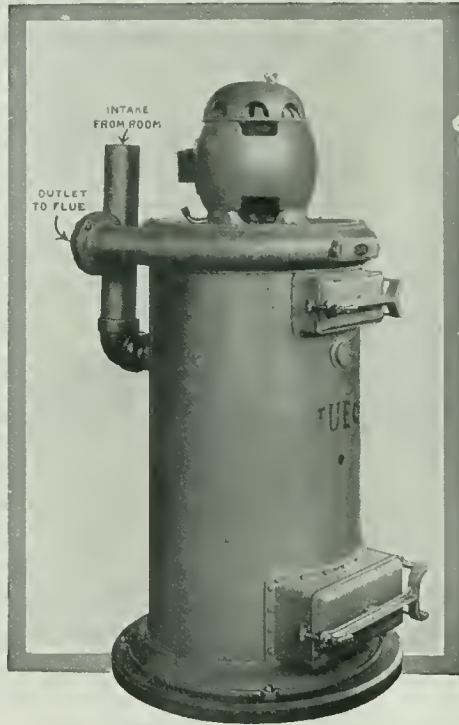

TUEC STATIONARY CLEANER.

THE cleaner that reduces building maintenance expense by keeping floors, walls, stairways, merchandise and other stocks, carpets, furniture and furnishings free from dust and dirt. No other cleaning device or dust removal method is so thorough, efficient, and economical. Investigate yourself and invite your client to do so. Write for our free catalog and full information.

THE UNITED ELECTRIC CO.
CANTON, OHIO.

Canadian Plant: Toronto, Ont.

California Distributors

S. F. COMPRESSED AIR CLEANING CO.
397 Sutter Street, San Francisco

BARKER BROS.
724 S. Broadway, Los Angeles

A. H. Bergstrom
Eric Lange

S. F. Phone Kearny 3526

LANGE & BERGSTROM

Building Contractors

(Established 1900)

207-210 SHARON BLDG.
San Francisco

WASHINGTON BLDG.
Los Angeles

TIMKEN BLDG.
San Diego

CONTRACTOR'S MACHINERY

RANSOME MIXERS

OSHKOSH MIXERS

INSLEY SPOUTING PLANTS

OSHKOSH EVEREADY SAW RIGS INSLEY STEEL CARS and TRACKS

HOISTING BUCKETS, HOPPERS, GATES, ETC.

STEAM AND ELECTRIC HOISTS

EVERYTHING USED BY CONTRACTORS

CARRIED IN STOCK BY

GARFIELD & CO.

Hearst Building, San Francisco

Phone Sutter 1036

Lakewood Building Mixers

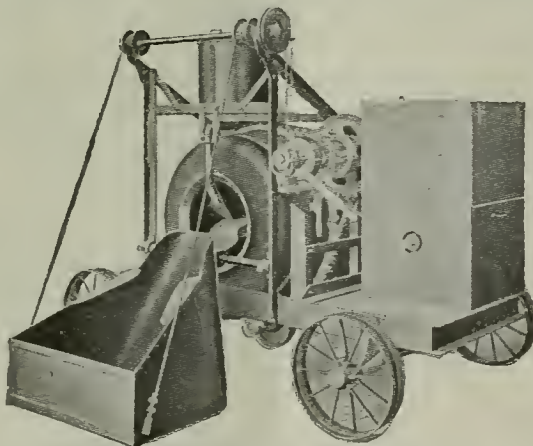

are in a class by themselves, as evidenced by repeated demands for these machines from large corporations and our most successful contractors. All merchantable sizes in stock—a complete line of equipment—steam, gasoline or electric power.

SMITH-BOOTH-USHER CO.

MACHINERY, SUPPLIES, PIPE AND FITTINGS

Factory Distributors

SAN FRANCISCO
50-60 Fremont Street

LOS ANGELES
228-238 Central Avenue

MILLER FOLDING IRONING BOARD

ELIMINATES WALL CABINET--IS INSTALLED IN KITCHEN CUPBOARD

NO { PLASTER GROUNDS
CASING OR PAINTING

SAVES { WALL SPACE AND LABOR
TIME AND MATERIAL

Exhibited and sold by { BUILDING MATERIAL EXHIBIT
77 O'Farrell Street, S. F., Tel. Sutter 5333

or LANNOM BROS. MFG. CO.
362 Magnolia St., Oakland.

MILLWORK Manufactured and Delivered Anywhere

Plans or Lists sent us for Estimates will have Careful and Immediate Attention.

Jno. Dudfield, Pres. and Manager **DUDFIELD LUMBER CO.** Joseph A. Jury, Sec'y & Mill Supt.
MAIN OFFICE, YARD AND PLANING MILL — PALO ALTO, CALIFORNIA

FRANK PORTMAN MILL AND CABINET WORK

Window Frames and Inside Finish A Specialty
Band Sawing, Sticking and Sand Papering

1618-20 MISSION STREET

SAN FRANCISCO

ALL KINDS OF
MOULDINGS
IN STOCK

Phone Park 6204

A. C. SCHINDLER, President.

CHAS. F. STAUFFACHER, Secretary

THE FINK & SCHINDLER CO.

Manufacturers of INTERIOR WOODWORK AND FIXTURES
BANK, OFFICE AND STORE FITTINGS
SPECIAL FURNITURE

218-228 THIRTEENTH ST.
Bet. Mission and Howard Sts.

SAN FRANCISCO, CAL.
Telephone: Market 474

O. BAMANN, President

ERNEST HELD, Vice-President

HOME MANUFACTURING CO.

BANK, STORE AND OFFICE FITTINGS
FURNITURE AND HARDWOOD INTERIORS
CABINET WORK OF EVERY DESCRIPTION

543 and 545 BRANNAN ST.

Phone Kearny 1514

San Francisco, Cal.

MULLEN MANUFACTURING CO.

BANK, STORE AND OFFICE FIXTURES—CABINET WORK OF
GUARANTEED QUALITY—CHURCH SEATING

Telephone Market 8692

Office and Factory:
64 Rausch St., Bet. 7th and 8th Sts., San Francisco

JAMES L. McLAUGHLIN

GENERAL CONTRACTOR

Phones Douglas 6615 - 6646

251 KEARNY STREET, SAN FRANCISCO

Dolan Wrecking & Construction Co.

(D. J. DOLAN)

Lumber, Lath, Nails, Shingles, Doors, Windows
and Plumbing Supplies, New and Second Hand

Phone Market 4264

Office and Yard, 1607-1639 MARKET ST., SAN FRANCISCO

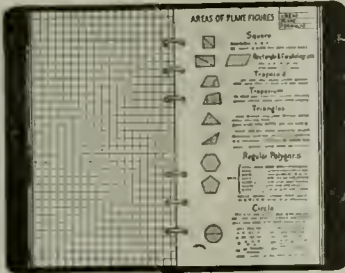

LEFAX

LEAF + FACTS

Pocket Cyclopedias

The facts that you want *instantly available* are not the same ones that some one else in your profession might desire. That's why LEFAX is made Loose Leaf. You file, in whatever order you wish, those sheets of facts that you want to have constantly at hand. If you wish, you may also file, in the same book, sheets for keeping data, for figuring, etc.

LEFAX sets cost but 50c. and \$1.00. You cannot fully appreciate their handiness—their value—until you use them. Ask us about them.

SCHWABACHER-FREY STATIONERY CO.
 PRINTERS LITHOGRAPHERS STATIONERS
 611 Market Street San Francisco

Steam Heating and Ventilating



For Commercial and Public Buildings

Furnace Heating
 For the Home

Mangrum & Otter, Inc.

827-831 Mission Street

Phone Kearny 3155 SAN FRANCISCO

Apartments and Stores

New work in the office of Mr. Earl Bertz, architect in the Foxcroft building, San Francisco, includes a frame apartment house for Mrs. Mary V. T. Lawrence to be built at 14th avenue and Fulton street, San Francisco, and a one story reinforced concrete store building on Sutter street, between Jones and Taylor streets, for Mr. H. B. Johnson. There will be six stores. The estimated cost is \$35,000.

String of Country Hotels

The San Joaquin Valley Hotel Corporation has been incorporated with a capital of \$1,000,000 for the erection of a chain of hotels in San Joaquin Valley, California. Among the cities in which it is proposed to erect buildings are Tulare and Dinuba. Plans for the buildings will be prepared by Mr. Leonard L. Jones, 468 Pacific Electric building, Los Angeles.

For Electricians

If her ways of thinking are not yours—converter.

If she goes up in the air—condenser.

If she wants something to eat—feeder.

If she sings sour—tuner.

If she is a poor cook—discharger.

If her dress is unhooked—connector.

If she is getting too fat—reducer.

ROBERTS MFG. CO.

Lighting Fixtures
 Electric Appliances
 Incandescent Lamps

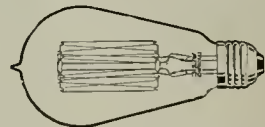

WILLYS FARM LIGHTING
 AND POWER PLANTS

663 Mission St., San Francisco

Washed Gravel and Sand

Quality For Concrete Construction *Service*

Thoroughly Washed and Accurately Graded—An Ideal Concrete Aggregate



View of Plant at Niles

California Building Material Co.

Plants at Eliot and Niles, Cal.

500 Call Building, San Francisco

Otis Elevators

THE Architect or Engineer can specify "Otis Elevators" assured that the responsibility of the Otis Elevator Company extends beyond satisfactory installation. Buildings equipped with Otis Elevators enjoy the advantage of the prompt service and careful inspection rendered by any of our hundred offices. Such service means your clients' gratitude.



Otis Elevator Company

Offices in All Principal Cities of the World
2300 Stockton Street, San Francisco, Calif.



