



75 CENTS

AMERICAN BUILDER

★ THE WORLD'S GREATEST BUILDING PAPER

REMODELING ISSUE

- 18 ideas: Heating and Air Conditioning
- 12 ideas: Roofing, Siding, Insulation
- 24 ideas: Walls, Ceilings, Floors
- 16 ideas: Windows and Doors
- 18 ideas: Bathrooms and Kitchens
- 15 ideas: Outdoor Living

JULY • 1956

Nothing Else Like NuTone..At Any Price !

NuTone

Guarantees Performance

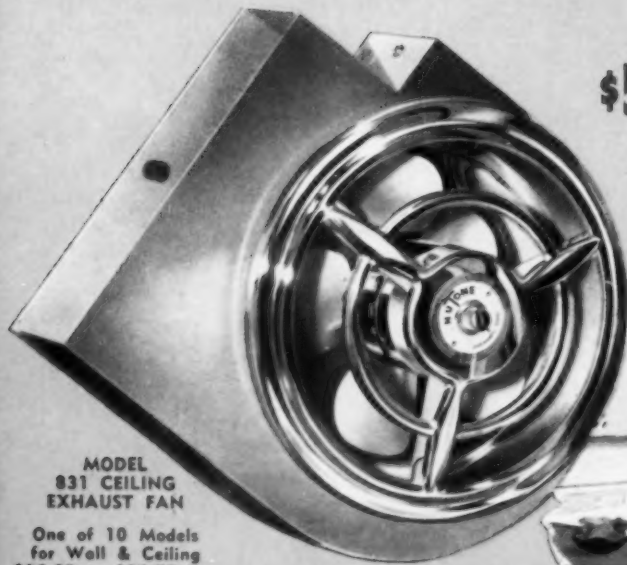

MODEL
831 CEILING
EXHAUST FAN

One of 10 Models
for Wall & Ceiling
\$19.95 to \$35.75 list.

No Other Exhaust Fan offers this
\$500,000.00 Service Policy

... Trouble-Free Performance
or NuTone Pays the Bill!

- Not just an ordinary Parts Warranty, but a Genuine Service Guarantee that pays for labor time if a "Call Back" is needed
- Nationwide network of NuTone Field Men work with Builders. No delay in service from distant factory.



HEAT-A-LITE or RADIANT MODELS
FOR TOASTY WARM BATHROOMS
\$24.95 to \$64.95 list.



HEATER plus LIGHT

U. S.
PATENTS
2,689,906
2,697,163
569,332

No Other Type of Heater offers the
SAFETY from Shock or Burn

... Because NuTone Heaters
are BUILT into the CEILING

- NO DANGEROUS WALL LOCATION. Out of harm's reach. No danger of accidental contact. U.L.
- Children can't poke fingers or toys into heating element.



FREE CATALOGS — Write NuTone, Inc., Dept. AB-7, Cincinnati 27, Ohio.

There are some things builders and architects can depend on—one is the faithful plumb bob . . . another is a Kwikset "400" line lockset in either Bel Air or standard design.

Every lockset that bears this name is made to exacting specifications of highest quality materials and workmanship. Simplified construction permits easy installation and insures trouble-free performance.

Ask your supplier about *dependable*, unconditionally guaranteed Kwikset "400" line locksets.



dependable

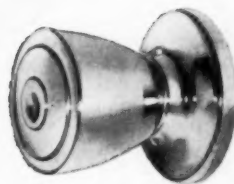

Bel Air design

"The Quality Lock for Budget Building"



KWIKSET SALES AND SERVICE COMPANY, ANAHEIM, CALIFORNIA



sliding door hardware is a better buy in price, too!



Feature for feature
STERLING 600 SERIES
*is better by comparison than
any other brand of sliding door
hardware.*

Sterling aluminum track is extruded, tempered, etched and anodized. Easier to paint. Looks good unpainted. Engineered to permit hanging or removing of doors with hangers attached. *No other brand offers these Sterling features.*

Twin Nylon wheels with OILED-FOR-LIFE bronze bearings are the quietest. Cadmium plated steel hangers with slotted screw

holes permit easiest plumbing of doors. *No other brand offers these Sterling features.*

Nylon and steel door guide takes only two screws . . . installs in seconds. *No other brand with these features.*

Door stop included in set . . . limits sliding action so rear door pull is always accessible. *No other brand with such quality features.*

*Send for our new 24-page catalog and
detailed information or see our catalog in Sweet's Files.*

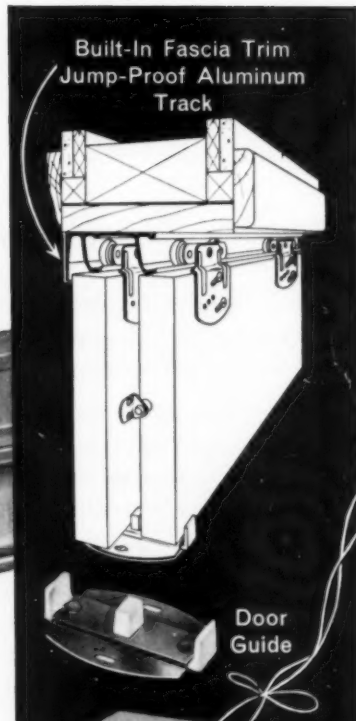

**FIGURES PROVE
STERLING IS BETTER
EVERY WAY!**
*Comparable Package Set List Prices
For Two 1-3/8" x 2'-0" By-Passing Doors*

Sterling "600"	\$10.80
Brand A	\$11.50
Brand B	\$11.89
Brand C	\$10.80
Brand D <small>Single wheel hangers</small>	\$10.45

John Sterling Corporation
Formerly STERLING HARDWARE MFG. CO.
2345 WEST NELSON STREET • CHICAGO 18, ILLINOIS

© 1956 JOHN STERLING CORPORATION, CHICAGO

The Opportunity Page

(Keynote page of the AMERICAN BUILDER, which is opportunity cover to cover, advertising and editorial)

Join your competition

If you're looking for a new way to increase attendance and sales at your new development, follow the lead of six "near neighbor" subdivisions in St. Louis County, Mo., which cooperated by opening at the same time. Said the developers: "Pack the kiddies and a picnic lunch into the family car . . . visit the subdivisions . . . then drive on for a picnic in the woods."

Food for thought

As more and more areas reach the "buyers market" stage, wise builders would do well to heed these remarks directed to the Building Research Institute by Melvin H. Baker, founder of the National Gypsum Co., and a vice-president of the U. S. Chamber of Commerce: "We can no longer afford to give the consumer what he ought to want rather than what he really wants. . . . Consumer is king in the present discretionary economy. . . . Consumer's decisions rule the action of manufacturer and economist alike. (For more on this, see Tomorrow's House, p. 17.)"

Tap a new market

A potential new market has opened up with the announcement that veterans may use GI benefits to secure VA loan guarantees on "second homes." Recent opinion issued by VA general counsel indicates that any summer home qualifies as long as it is "constructed and equipped for year-around living."

Multi-price grouping pays off

Careful design selection and the use of generous size lots allows a builder to group homes in a wide price range—as from \$18,000 to \$30,000. Seattle

builder Jack E. Counts, who carried out such grouping in his Glendale Country Club Estates, says the varied price factor works in favor of, rather than against, his homes. One reason: desire of those owning smaller homes to purchase larger ones in the same development as family size grows.

Remodeling know-how

Have you been getting your share of that \$10.5 billion remodeling bonanza? Profits from remodeling are being made all over the nation where OHI and urban renewal are in full swing. American Builder's Remodeling Workbook—covering everything from roofs to basements—starts on page 73. You can put these ideas to work for you and put some of that cash in your pocket.

Play up your strong points



PRICE



STERN

If you're building in a tornado, hurricane or bomb-blast belt (and who isn't these days?) take a new advertising tack by stressing the superior strength of your houses. V.P.I. expert George Stern and builder A. E. Price, of Blacksburg, Va., show you how on page 104. And, they also give you some cost-cutting, space-saving tips that apply to almost any builder who features frame construction.

3 problems—1 solution

Land, mortgage money and sales are the thorniest problems confronting the industry, reported president Joseph Haverstick at the NAHB spring directors' meeting. To learn how eight smart builders from Austin, Tex., solved the land shortage problem, see AB's feature story on page 116.

American Builder is published by the SIMMONS-BARDMAN PUBLISHING CORPORATION, Emmett St., Bristol, Conn., with editorial and executive offices at 30 Church St., New York 7, N.Y.

James G. Lyne, President; Arthur J. McIlinnis, Executive Vice President and Treasurer; Samuel G. Dunn, Chairman Emeritus; J. S. Crane, Vice President and Secretary; Fred A. Clark, Vice President

and Business Manager; Edward G. Gavin, Vice President and Editor; Bayne Sparks, Vice President; Robert G. Lewis, Vice President.

Heating Split-Levels with a combined floor panel and baseboard system

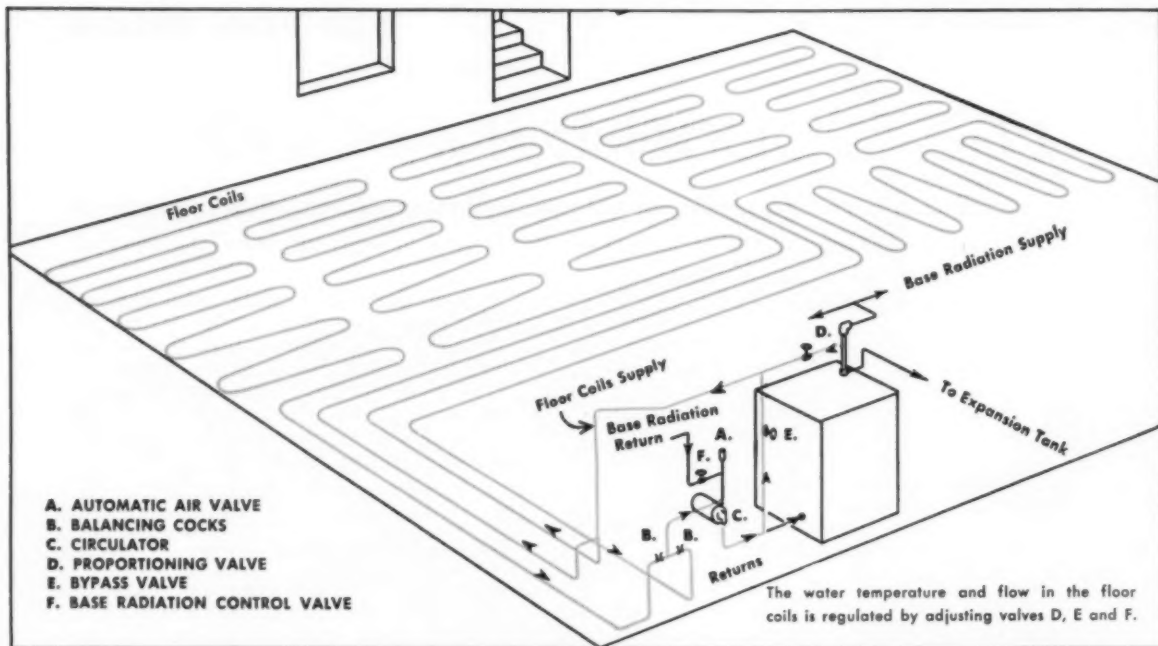

Anaconda Pre-Formed Panel Grids of Copper Tube to heat lower level give builder big sales advantage. One big problem in split-level homes has been the cold floors of below-grade rooms. In Builder Joseph Fleming's homes,

babies play in comfort on all floors. Drawing shows how Mr. Fleming and his plumbing contractor, Joseph Forrest, designed the floor radiant panel installation and upstairs baseboard system to operate with one circulator.



Typical home in Builder Fleming's "Shipley Heights" development, Wilmington, Delaware.



Anaconda Panel Grids (PG's) are machine-formed radiant-heating coils containing 50 linear feet of Type L Copper Tube. Available in two nominal sizes, $\frac{3}{8}$ " for ceiling installations and $\frac{1}{2}$ " for floor panels, they come to the job ready to install.



Plumbing Contractor Forrest (above) says, "The saving in installation time using Anaconda Panel Grids enabled us to give Mr. Fleming a better heating job at lower cost. I knew what PG's could do in the way of cutting costs, for I had used them in my own home."

See how PG's® can reduce your costs. Write for Anaconda Publication C-6. Address: The American Brass Company, Waterbury 20, Conn. In Canada: Anaconda American Brass Ltd., New Toronto, Ont.

ANACONDA® COPPER TUBE PRE-FORMED PANEL GRIDS FOR RADIANT PANEL HEATING

Available through distributors of Anaconda Pipe and Tube

“NOBODY COVERS AMERICAN BUILDING LIKE THE AMERICAN BUILDER”

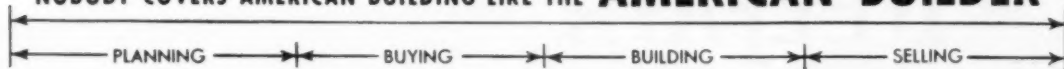

Editor Edward G. Gavin
 Executive Editor Joseph B. Mason
 Managing Editor Walter R. Browder

Art Director Russell F. Rypsum
 Assistant Art Director Morris Neuwirth

News Editor Garrett Winter
 Assistant News Editor June Vollman
 Architectural Editor William F. Koelling
 Construction Editor Maxwell Huntoun

Features Editor Oscar Shaftel
 Technical Editor William Dukes
 New Products Editor Sally Anne Gassert
 Production Editor Robert Rossner

Western Editor William C. Kodd
 Washington Editor Walter J. Taft
 Executive Editor, April Marketing Directory Charles H. Goodall
 Research Director J. W. Milliken
 Assistant Research Directors E. Kenneth Bates
 Constance Nicolai
 Director, Home Plans Service Charles L. Combes
 Legal and Tax Consultant John F. McCarthy
 Editorial Assistants Gertrude M. Pelnar
 Carol Snyder

Editorial Office:
 30 Church St., New York 7, N. Y.
 April issue: 79 W. Monroe St., Chicago 3, Ill.

Director of Production M. J. Figa, Jr.
 Sales Promotion Lyman M. Forbes

Advertising Sales Representatives:
 New York 7, N. Y., 30 Church, Bayne Sparks
 WO-4-3060 W. J. Kane
 Banks Wanamaker

Chicago 3, Ill., 79 W. George Hutchings
 Monroe, RA-6-0794 David Rompel

Cleveland 13, O., Terminal D. T. Brickner
 Tower, MA-1-4455 D. J. Casey

Dallas 19, Tex., 3908 Lemmon Joe Sanders
 Ave., Lakeside 2322

Los Angeles 17, Cal., Fred Klaner, Jr.
 1127 Wilshire, Ma. 6-0553

Portland 5, Ore., 1220 S. W. L. B. Conaway
 Morrison, Capitol 7-4993

Toledo 6, Ohio, 3545 Lincolnshire Harold Mann
 Woods Rd., Lyceum 2801

San Francisco 4, Cal., 244 Calif., Lewis Vogler
 Ga. 1-7004

Publisher Arthur J. McGinnis
 Business Manager Fred A. Clark
 Sales Promotion Director Fred Lesner

American Builder (originally "Carpentry and Building") with which are incorporated Building Age, National Builder, Permanent Builder, and the Builder's Journal, was founded Jan. 1, 1879. Names registered in U.S. patent office and Canadian registrar of trade mark.

Address all subscriptions and correspondence concerning them to: Subscription Department, American Builder, Emmett St., Bristol, Conn. Changes of address should reach us three weeks in advance of next issue date. Send old address with the new enclosing if possible your address label. The Post Office will not forward copies unless you provide extra postage. Duplicate copies cannot be sent. Circulation Department: H. C. Van Ness, Director of Circulation; Field Staff: Gerald Blackley, Chester Hanson, George Heinrich, Guy Hill, Ash Huse, Steve Jacobson, J. Hansell Lewis, Don Paul, John Simonson, Earl Spohn.

Published monthly by Simmons-Boardman Publishing Corporation, Emmett St., Bristol, Connecticut. Editorial and Executive Offices, 30 Church Street, New York 7, New York. Subscription price: United States, Possessions and Canada, 1 year, \$3.50; 3 years, \$7.00. Foreign countries: 1 year, \$12.00; 3 years, \$25.00. Single copies, 75 cents. April issue, \$2.00. Entered as second-class matter July 20, 1950, at the Post Office of Bristol, Connecticut, under the act of March 3, 1879. Copyright 1956 with all rights reserved. SIMMONS-BOARDMAN PUBLISHING CORP.

READER'S GUIDE

JULY

- 3 The Opportunity Page
- 5 Reader's Guide
- 7 Reader's Guide to Advertising
- 9 Impact
- 11 The Building Outlook
- 13 Pulse of Building
- 17 Tomorrow's House

- News
- 23 National news
 - 25 Dickerman's column
 - 26 Northup's column
 - 27 News of your region

AMERICAN BUILDER'S REMODELING ISSUE

- 73 Your 1956 remodeling opportunity
- 74 How to make a hot house a cool house
- 76 How to put new warmth into old houses
- 78 How to wrap a new surface around the house
- 80 How to dress up old walls with new surfaces
- 82 How to surface interior walls with little effort
- 84 How to build in beauty underfoot
- 86 How to bring new brightness inside
- 88 How to let in light from every direction
- 90 How to remodel with new doorways
- 92 How to update an old bathroom
- 94 How to remodel your most important room
- 96 How to install kitchen sales extras
- 98 How to extend living space outdoors
- 100 How to update around the house
- 102 How to add important extras

- Houses & Plans
- 30 House of the month from your region
 - 104 Blueprint House: How to build a better small house for less money
 - 116 Here's how teamwork solved the land crisis

- Departments
- Cover photo: Ewing Galloway
- 119 The Payoff Departments
 - 147 Supermarket for Builders
 - 149 New products and equipment
 - 201 Catalogs and manufacturers' literature
 - 212 Builder's library
 - 218 How to do it better
 - 222 Ask the experts: Reader queries analyzed
 - 226 Keeping up with the law
 - 232 Technical guide: Remodeling with red cedar shingles
 - 240 Better detail plate: Remodeling with corrugated ceilings
 - 246 The Month Ahead

READER'S GUIDE TO ADVERTISING ON PAGE 7 →



DELFAIR[®]
Oakstrip

**Brings to every
home the beauty
and durability
of oak...**

DELFAIR OAKSTRIP FLOORS are available
factory-finished or unfinished.

Beautiful Delfair Oakstrip is certain to appeal to every homeowner . . . for it possesses both the beauty and durability of oak. Builders and dealers can win complete customer satisfaction with Delfair Oakstrip. Whether you build one or one hundred or more houses, plan now to enjoy the advantages of this outstanding flooring.

*... The Name To Remember
When You Buy Oak Flooring*



D. L. FAIR LUMBER COMPANY LOUISVILLE, MISSISSIPPI
OAKSTRIP • OAKBLOK • OAKPLANK • MULTI-WOOD BLOK • FINISHED OR UNFINISHED

Advertising

"The better you plan—the better you buy—the better you build—the better you sell" ©

A

A & A Register Company, The	242
Admiral Corporation	56
Allianceware, Inc.	46
American Brass Company, The	4
American Builder	121, 212-214, 221, 228, 242
American Floor Surfacing Machine Co., The	239
American Kitchens Division, AVCO Manufacturing Corp.	154, 155
American Steel & Wire Division, United States Steel Corporation	37
American Telephone & Telegraph Co.	141
American Window Glass Co.	136
Andersen Corporation	14, 15
Arco Company, The	156
Asbestos Cement Products Association	72

B

Bakelite Company, a Division of Union Carbide and Carbon Corporation	58, 59, 172
Barber-Colman Company	208
Barrett Division, Allied Chemical & Dye Corporation	159
Bessler Disappearing Stairway Co.	202
Bethlehem Steel Company	28
Better Homes & Gardens	227
Bilco Co., The	162
Black & Decker Mfg. Co., The	160
Bostitch	125
Briggs Manufacturing Co.	12
Brown & Company, Inc., Geo. C.	238
Brown Company	64
Bruce Co., E. L.	145
Burr-Southern Corp. of Calif.	209

C

C & H Supply Co.	170
Case Manufacturing Corporation	144
Certain-Teed Products Corporation	200
Champion Mfg. Co.	226
Chase Brass & Copper Co.	197
Chicago Tribune	209
Cincinnati Iron Fence Co.	178
Classified Advertising	243
Clipper Manufacturing Co.	29
Columbia-Geneva Steel Division, United States Steel Corporation	37
Condensation Engineering Corporation	237
Construction Costs Institute	224
Crown Tile Corporation	179

D

Deere, John	195
Dodge Corporation, F. W.	215
Douglas Fir Plywood Association	161, 163, 165, 167
Dow Chemical Company, The	126, 127
Dur-O-wal Division, Cedar Rapids Block Company	66

E

Edwards Company, Inc.	219
Efron Mfg. Co., Theodore	164
Electromode Division, Commercial Controls Corporation	245
Elier Division of the Murray Corporation of America	153
Emerson Electric Mfg. Co., The	52, 53

F

Fair Lumber Company, D. L.	6
Farley & Loetscher Mfg. Co.	63
Fasco Industries, Inc.	194
Fleet of America, Inc.	210
Flintkote Company, The	216
*Forest Fiber Products Company	32F
Foumca Company, The	Cover 3
Frantz Manufacturing Company	242
*Fuller & Co., W. P.	32D, 32E

G

Gates & Sons, Inc.	202
*General Concrete Products, Inc.	32G
General Electric Company	16, 229
General Electric, Textolite Division	8
General Products Company, Inc.	191
Giles & Kendall Company	162
Goldblatt Tool Company	178

*Appears in Western edition only.

Gold Seal Division, Congoleum-Nairn, Inc.	112
*Goodwin of California	32B
Graham Industries, Inc.	237
Grant Pulley and Hardware Corporation	225
Gyro Brass Mfg.	202

H

Hager & Sons Hinge Mfg. Co., C.	134
Hall-Mack Company	43
Hansen Mfg. Co., A. L.	243
Henry Manufacturing Company, Inc.	241
Holcomb & Hoke Mfg. Co., Inc.	189
Homasote Company	42
Homelite, a division of Textron American, Inc.	186, 187
Hope's Windows, Inc.	239
Hotpoint Co.	33-36
Hunter Fan and Ventilating Company	220

I

Independent Nail & Packing Co.	223
Infra Insulation, Inc.	10
Inland Steel Products Company	118
Insulite Division, Minnesota and Ontario Paper Company	138, 139
International Oil Burner Co.	217

J

Johns-Manville	191
----------------	-----

K

Katolight Corporation	202
Keasbey & Mattison Company	133
Kees Mfg. Co., F. D.	40
Kennatrack Corporation	206
Kentile, Inc.	140
Kohler Co.	146
Kwikset Sales and Service Company	1

L

Legion Stainless Sink Corporation	164
Leigh Building Products Div., Air Control Products, Inc.	22
LeTourneau-Westinghouse Company	196
Levelall, Thom-Wood Company	178
Libbey Owens Ford Glass Company, Thermopane	132
Live Better Electrically	44
Lockley Machine Company	191
Lockwood Hardware Manufacturing Company	57
Long-Bell Lumber Company, The	135

M

Macklanburg-Duncan Co.	38, 39
Majestic Co., Inc., The	184
Marsh Wall Products, Inc.	62
Masonite Corporation	18
Meadows, Inc., W. R.	179
Mengel Company, The	171
Midget Louver Co.	40
Milwaukee Electric Tool Corp.	235
Minnesota and Ontario Paper Company, Insulite Division	138, 139
Morgan-Wightman Supply Co.	185
Mueller Brass Co.	54, 55
Muller Machinery Company, Inc.	202, 209
MusiCall Corporation	174

N

National Clay Pipe Manufacturers, Inc.	50
National Gypsum Company	182
National Manufacturing Co.	Cover 4
National U. S. Radiator Corporation	49, 68
New Castle Products, Inc.	137
NuTone, Inc.	Cover 2

O

Olin Film Division	157
Omak Industries	158
Onan & Sons Inc., D. W.	174
Orangeburg Manufacturing Co., Inc.	120
Owens Illinois Glass Block, Kimble Glass Company subsidiary	230

P

*Pacific Telephone	32H
Penn Metal Company, Inc.	205
*Pioneer-Flintkote	32C
Pittsburgh Plate Glass Company	164
Portland Cement Association	68
Progress Manufacturing Co., The	19

R

Ramset Fastening System	188
Remington Arms Co., Inc.	192
Republic Steel Kitchens	193
Rheem Manufacturing Company	51
Rilco Laminated Products, Inc.	178
Rocform Corporation	67
Rowe Manufacturing Co.	41
R. O. W. Sales Company	20, 21
Ruberoid Co., The	211

S

Saint Paul Corrugating Co.	224
Samuel Stamping & Enameling Co.	207
Sasgen Derrick Company	176
Saturday Evening Post	128, 129
Scholz Homes, Inc.	198
Sherman Products, Inc.	45
Solvay Process Division, Allied Chemical & Dye Corporation	235
Southern Sash Sales & Supply Company, Inc.	168
Speed King Manufacturing Co.	170
Stanley Hardware, Div. of The Stanley Works	180
Sterling Corporation, John	2
Stow Manufacturing Co.	199
Symons Clamp & Mfg. Co.	187
Syntron Company	236

T

Tennessee Coal & Iron Division, United States Steel Corporation	37
Textolite Division of General Electric Company	8
Timber Engineering Company	243
Trade-Wind Motors, Inc.	32
Typhoon Air Conditioning Company	60

U

Uni-bilt Division, Vega Industries, Inc.	183
Unique Balance Company, Inc.	173
United States Gypsum	122, 123
United States Plywood Corporation	69
United States Steel Corporation, United States Steel Export Company	37
United Steel Fabricators, Incorporated	63
Universal Atlas Cement Company	61

V

Vent-A-Hood Company	190
Vento Steel Products Co., Inc.	204
Virden Co., John C.	175
Visador Co., The	66

W

Washington Steel Products, Inc.	169
Waterfilm Boilers, Inc., a Division of L. O. Koven & Bro., Inc.	40
Weiser Company	181
Western Lock Mfg. Co.	177
Western Fine Association	245
Westinghouse Electric Corporation	70, 71
Weyerhaeuser Sales Company	142, 143
White Company, David	206
Williamson Company, The	47
Winchamper Corporation	176
Winfield Door Corporation	48
Woodco Corporation	124
Wood Conversion Co.	130, 131
Woodward Iron Company	166
Worthington Corporation, Air Conditioning and Refrigeration Div.	203

Z

Z & K Tool Company	191
--------------------	-----

© 1956 American Builder

"CRACKLE"—a trend-setting pattern, in 5 gay colors

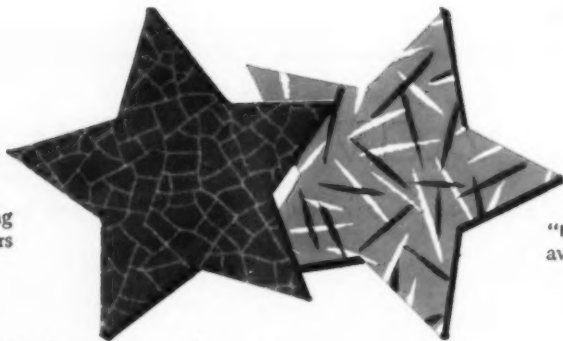

"HEYDAY"—a modern design, available in 5 gorgeous colors

General Electric presents...

2 NEW SALES "STARS" in the G-E Textolite line



 **Textolite**[®]

PLASTIC COUNTER SURFACING

Here they are—"Heyday" and "Crackle"—the two great, new, G-E Textolite patterns you first saw previewed at the NAHB Show in Chicago last January. Like all G-E Textolite surfaces, they'll stay bright and beautiful, because they resist *heat, stains, and scratches*. And, with Textolite on counters

★ ★ ★

OVER 75 PATTERNS AND COLORS are yours with G-E Textolite! Woodgrains, Marble designs... and special G-E patterns like Medley, Ming, and Cross Current, are all highly styled to appeal to your prospects—and to help make that sale—right in the kitchen.

and walls—you can literally offer your prospects "years of wear—with minutes of care." Textolite wipes clean in a jiffy... needs no special maintenance! So, whenever you want the practicality of plastic, plus long-wearing beauty—be sure to specify G-E Textolite surfacing.

General Electric Company
Section AB 7-6, P.O. Box 5911
Cleveland 1, Ohio

Please send me the new 1956 full-color booklet with a complete selection of G-E Textolite patterns.

Name _____

Firm _____

Address _____

City _____ Zone _____ State _____

GENERAL  **ELECTRIC**

Impact

To The Editors:

American Builder
30 Church Street
New York 7, N. Y.

From the Authority

Sirs: Thank you for sending me tear sheets of the third article in the American Builder series on bathroom planning, covering accessories.

All of us at the Bureau were greatly pleased at the way the subject was handled.

—C. F. Craigie, Jr., Plumbing and Heating Industries Bureau Chicago, Ill.

Another article on bathrooms is planned for the near future.

From Israel

Sirs: I have read with great interest about the "Nail-on Face Brick" in American Builder of Feb. 56, p. 163.

Due to the uninterrupted immigration since 1948 and in order to supply schools we were obliged to use prefabricated wooden school buildings in the country. A big part of them are imported from Sweden, Finland and others are prefabricated on site. Now it becomes a great need to begin with the remodeling of them . . . It's much easier to see the advantage than to read about them. That's why I would like to have a sample of real material in order to obtain a good demonstration. Our brick dimension of silicate bricks is (inches scale) $3\frac{1}{2} \times 4 \times 8\frac{3}{4}$.

—H. A. Kashdan, Arch. A.E.A.I., Consultant for School Buildings, Ministry of Education and Culture, Jerusalem, State of Israel.

Copy of letter was forwarded to manufacturer, Ludovici-Celadon Co., Chicago.

Postman's Prayer

Sirs: In the April "Impact" a letter from William Absolon of Chicago, mail carrier, makes an appeal for someone with an inventive turn of mind to develop a mail receiver that will do a little more than be big enough for the postcard from Aunt Minnie.

We felt you would be interested to know that someone has done just this, in fact, even a little more. A home and office receiver has been developed and is now on the Canadian market that is not only large enough to take all types of mail, including magazines, papers and small parcels, but is so built and designed that these go directly into the home or office.

We are enclosing literature on Postie's Delight . . .

—Jas. R. Boyd, Gen. Man., Household Inventions Syndicate Calgary, Alberta

A column in the Winnipeg Tribune says that Jim Boyd got the idea after his wife complained about the old style slot; it jelled about 4 a.m. one day, when the wind was howling and the snow coming in the slot. A companion product is "Milkman's Delight."

"New Look" Gets Bouquet

Dear Sirs: Your "new look" keeps getting better, and I couldn't help saying so after putting down the June issue which came across my desk today . . .

—Thomas C. Sias, publicity director, Douglas Fir Plywood Association, Tacoma, Wash.

Glad to hear you say so; next month, when we switch to a new type-face (Times Roman) for the book, we hope you'll like it even better . . .

"A Perfect Backdrop"

Sirs: I have been much impressed by the changes and improvements in American Builder in the last year, and so enthusiastically so, that . . . I write to your office and formally send my compliments.

May I take this opportunity to congratulate your entire staff on doing such a wonderful job and to wish you many, many more years of continued success in the publishing of The American Builder.

—George W. Lyons, Jr., vice-president, The Bilco Co.

New Haven, Conn.

Music to the staff's collective ear.



"Let's take a peek at those good old blueprints again, Sam . . ."

(Cartoon by Virgil Partch—
Courtesy Pomona Tile Manufacturing Co.)

FOR SUMMER COMFORT, the U. S. National Bureau of Standards rates multiple layers of aluminum FIRST

among all insulations it tested, as reported in its booklet,
"Effect of Ceiling Insulation upon Summer Comfort," BMS52.

(You can get it at our expense.)

To be comfortable in summer you must ward off unwanted heat rays or radiation. Most heat flow thru a *roof space* in summer is by radiation. There is no convection down, and little conduction thru low density air.

Temperatures can reach over 140° F. in some attics. With an absorptivity for heat rays of only 3%, reflectivity 97%, and emissivity 3%, scientific multiple aluminum is an effective shield against summer heat. The slight mass of its components, air being preponderant, makes it very low in heat storage.

COST OF AIR-CONDITIONING REDUCED

This shield against radiant heat lifts part of the load from house-cooling equipment, reducing installation and up-keep costs. But the building which is *not* artificially cooled, needs this shield even more!

Multiple aluminum is also markedly effective against radiation through a *wall space*.

Air of higher outside temperatures will support more vapor than the cooler air inside a building. Often vapor flows from the outside to the inside of the house, obedient to the law of physics that vapor travels from areas of greater density to areas of less vapor density.

Multiple aluminum has long, continuous metallic sheets on *both* sides which are almost impervious to water vapor. Infiltration under the flat, stapled flanges is slight. The scientific construction of multiple layers of aluminum, fiber and air spaces, minimizes condensation formation on or within this type of insulation. Timber rot, crumbling plaster, peeling paint, etc. are minimized.

CAUTION: *We do not recommend placing vapor barriers on both sides of all insulations.*

IN WINTER, NEED FOR INFRA EVEN GREATER

The low conductivity, the slight heat ray absorptivity and emissivity of scientific multiple aluminum, and the retarding of inner and outer convection by the multiple layers of metal and fiber, amazingly effective in summer, assume paramount importance in winter when this 3-fold bar to outward heat flow cuts fuel bills and increases comfort.

To obtain MAXIMUM, uniform-depth protection against heat loss and condensation formation, it is necessary to use the new **edge-to-edge** multiple aluminum*, each sheet of which stretches from joist to joist.

*Patent applied for

INFRA INSULATIONS CAN BE PURCHASED everywhere through your preferred local dealer for 3¢ to 12¢ per sq. ft. depending on the type.



Infra Insulation Inc., Dept. B7
525 Broadway, New York, N. Y.

- Please send FREE U. S. Bureau of Standards Booklet BMS52
- Please send samples

Name _____

Firm _____

Address _____

The Building Outlook

SMALL TALK

TRADE-INS GET THE NOD

If you haven't already adopted a trade-in plan, you may soon have to. Now that FHA has approved the program, more and more prospective buyers will insist that their old houses be made part of any deals involving new homes.

A PEEK AT THE FUTURE

Architecturally, the house of 1980 probably won't differ greatly from those of today. That's the word from NAHB president Joseph Haverstick who does see a possibility that heliports will replace garages or carports by that time.

CASH IN ON COLOR

Look for increased use of pastel colors on home exteriors. New masonry exterior paints, mixed with water, show only a slight fading which is not noticeable when applied to an entire house. Use of diverse colors will break up the "peas-in-a-pod" appearance of subdivisions, attract buyers.

WHAT IS AN INCH?

That's the question FHA is asking about one-inch boards. Recent confusion within the lumber industry over board thickness has resulted in FHA extending its temporary acceptance of 3/4-inch boards until the industry settles the question.

WHAT DO THEY WANT?

Did the women mean it when they told HHFA they wanted more space in new houses? To learn the answer American Builder asked the experts—builders from all sections of the country. You'll find out what they said and how they're meeting the problem in AB's survey feature on page 23.

NORTHERN EDITION

A BIG SWING TO FOUR-BEDROOM HOMES

is under way. Especially in the New York area, builders report that an adequate number of bedrooms has become the most important factor in a buyer's choice of a house, taking priority over style, kitchen layout and other eye-catching selling points.

IS THE TWO-STORY HOUSE COMING BACK

INTO VOGUE? In areas where land is at a premium, buyer demand for additional space is leading builders to look to the two-floor home as the answer. Although stairs are not popular, home buyers will accept them to obtain extra space at less cost. This is indicated by the continuing popularity of split levels.

A TAPERING OFF OF THE GI LOAN PROGRAM,

rather than its abrupt end in July, 1957, now seems a definite probability. Chief obstacle to its continuance has been criticism by many congressmen regarding "shoddy" building and discounting of guaranteed mortgages. However, bills have been introduced to meet these problems, and Washington observers expect Congress to vote for a gradual slow-down for World War II veterans' loans.

A BULLISH OR BEARISH MARKET?

That's one big question facing the industry. Long-range optimistic views come from Jerry Madigan, NAHB field service director, who sees an unprecedented housing boom beginning in 1962 with housing starts expected to jump between 1,500,000 and 2,000,000. Concurring is Wyn Warman, vice-president, U. S. Savings & Loan League, who also sees an annual pace of 1,500,000 starts by 1960. Meanwhile, Madigan joins others taking a more cautious view for the immediate future, saying that the current "lull" in housing starts probably will continue through 1958, but will not drop below 1,000,000 units a year.

MODERN STYLING

WITH REAL SALES APPEAL



The Lindsay open front model—permitting installation in narrow 16-inch counter tops—is the newest and most practical thing in built-in lavatory design. Stainless steel union strips.

The Deluxe Lowell lavatory is the finest of flat rim models which are so popular for single or twin counter-top installation. Preformed, stainless-steel mouldings assure tight, leak-proof fit.

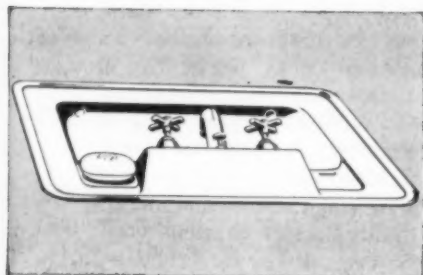

Convenience Features such as soap-space, concealed overflows and anti-splash rim contribute greatly to the value of Beautyware lavatories.

Modern living calls for smartly styled, functionally designed lavatories — and **PLENTY OF THEM** for family needs.

Here are three Beautyware models which can improve your bathroom installations. All three offer superior quality, durability and color processing.

Scientific design and manufacture of all Beautyware lavatories assure accurate and simplified installation — trouble-free, long-life operation. Gleaming, easy-to-clean finishes — precision brass fittings — and choice of five distinctive nature colors — are all strong selling features.



The Whittier is typical of the many Beautyware wall-mounted models available in shelf-back, ledge-back or stand-back design. Optional legs and towel bars require no special wall attachments—are simply installed.

BRIGGS[★] Beautyware

BRIGGS MANUFACTURING CO., 300 Buhl Building • Detroit 26, Michigan

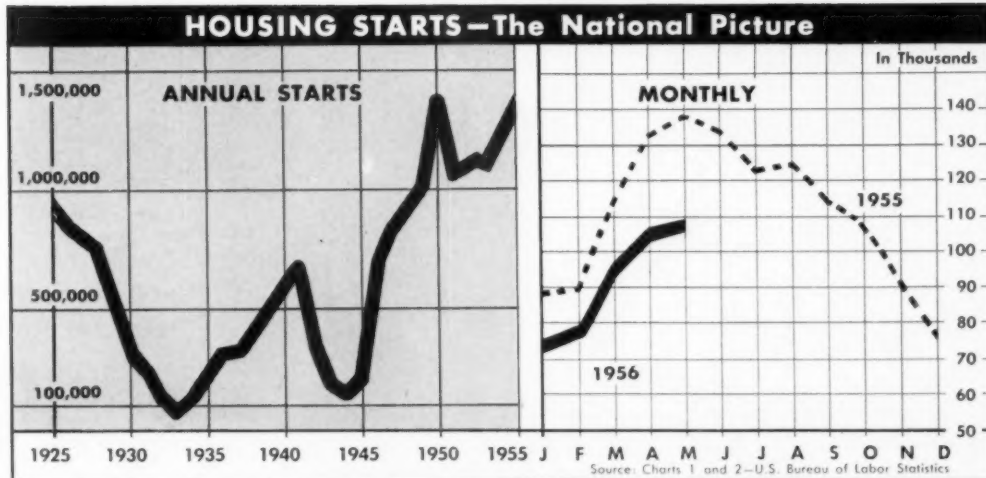

Interpretation 1

108,000 MAY STARTS were 20% below May, 1955. Seasonally adjusted annual rate of 1,160,000 (Jan.-May) indicate 1956 may be first year of starts under 1,200,000 since 1953.

With VA and FHA mortgages especially difficult to obtain, units begun under VA and FHA inspection fell from half the private total in 1955 to 40% during April and May. VA appraisal requests, a forerunner of starts, levelled off in May after a promising upturn in April; applications for FHA insurance continued at a relatively low rate compared with the same months in recent years.

15 LEADING HOME BUILDING AREAS

Dwelling units built in Metropolitan areas during first two months of 1956. (BLS)

		% Change Jan.-Feb. 1955-56
Los Angeles	17,630	+ 7
New York	10,910	- 8
Chicago	6,285	+24
Detroit	4,513	- 4
San Francisco	3,099	-27
Miami	2,613	-14
Washington	2,047	-34
San Diego	1,806	-10
Baltimore	1,716	-54
Atlanta	1,608	-14
Cleveland	1,528	-12
Denver	1,432	-14
Phoenix	1,352	-31
Boston	1,243	-15
Seattle	1,122	-27

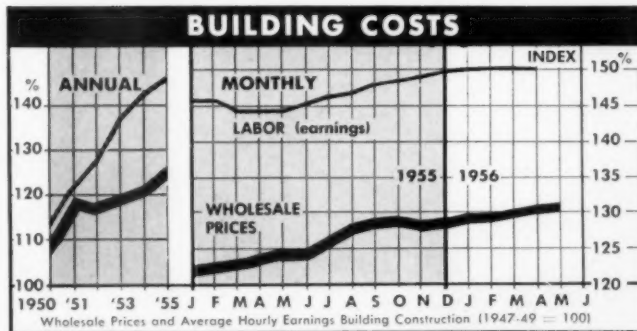

2

SLIGHT DIP in wholesale price index to 130.9 for first time since November was due mainly to sharp cut in metal door prices. Hourly earnings dipped fractionally to 150.5.

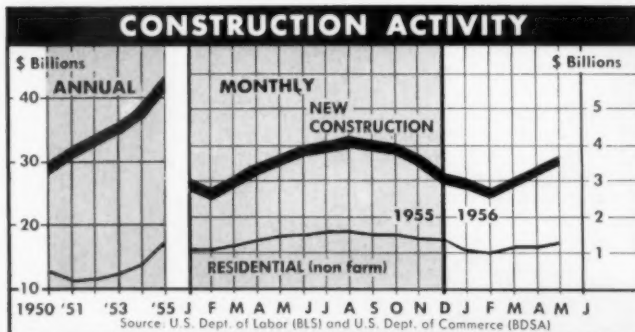

3

MATCHING MAY, 1955 RECORD, the \$3.7 billion spent in May reflected a rise in almost all construction. Factory building rose to a new high for third month in a row.

Here's window beauty
that sells homes



Andersen *Windowalls*

TRADEMARK OF ANDERSEN CORPORATION

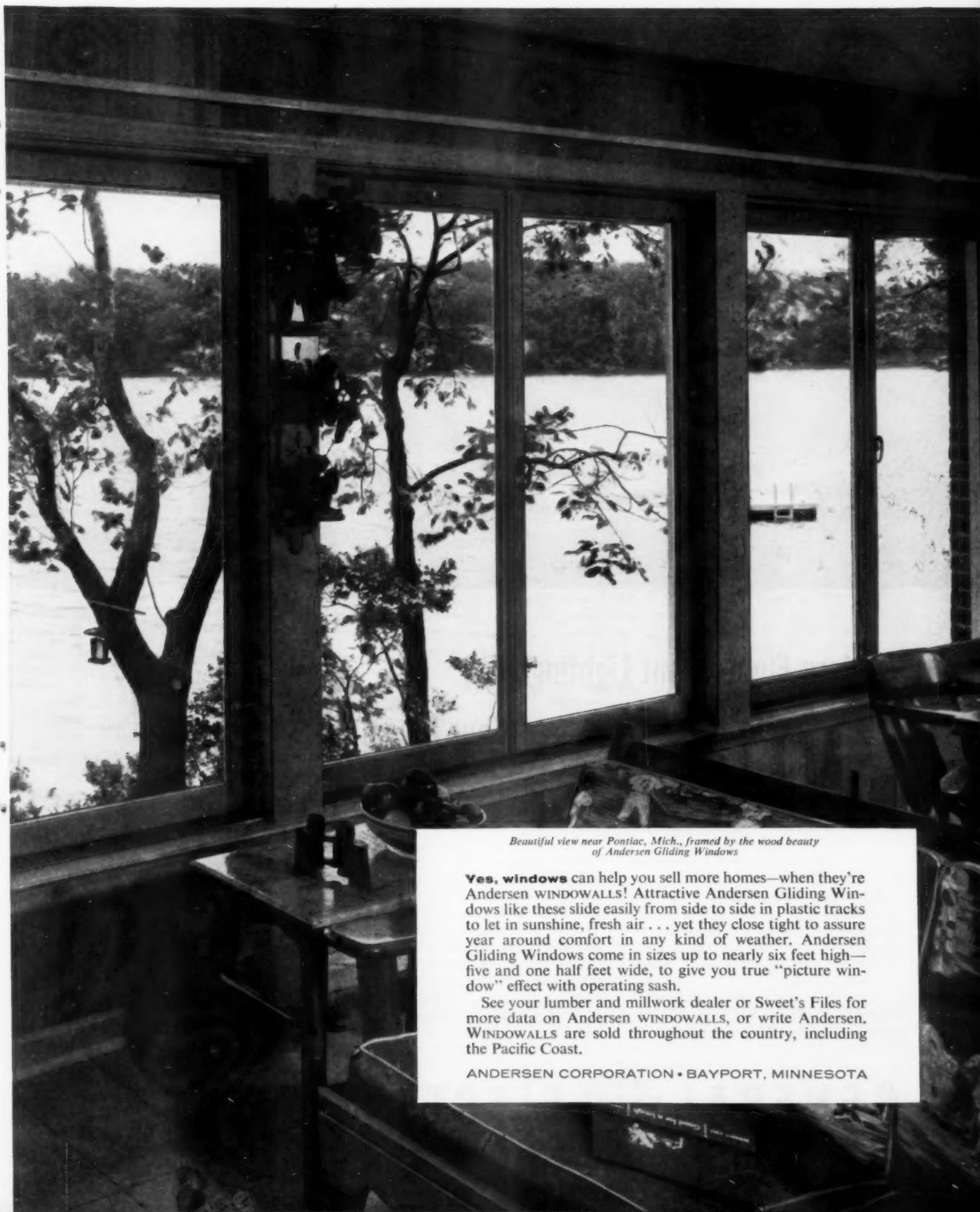

Beautiful view near Pontiac, Mich., framed by the wood beauty of Andersen Gliding Windows

Yes, windows can help you sell more homes—when they're Andersen WINDOWALLS! Attractive Andersen Gliding Windows like these slide easily from side to side in plastic tracks to let in sunshine, fresh air . . . yet they close tight to assure year around comfort in any kind of weather. Andersen Gliding Windows come in sizes up to nearly six feet high—five and one half feet wide, to give you true "picture window" effect with operating sash.

See your lumber and millwork dealer or Sweet's Files for more data on Andersen WINDOWALLS, or write Andersen. WINDOWALLS are sold throughout the country, including the Pacific Coast.

ANDERSEN CORPORATION • BAYPORT, MINNESOTA

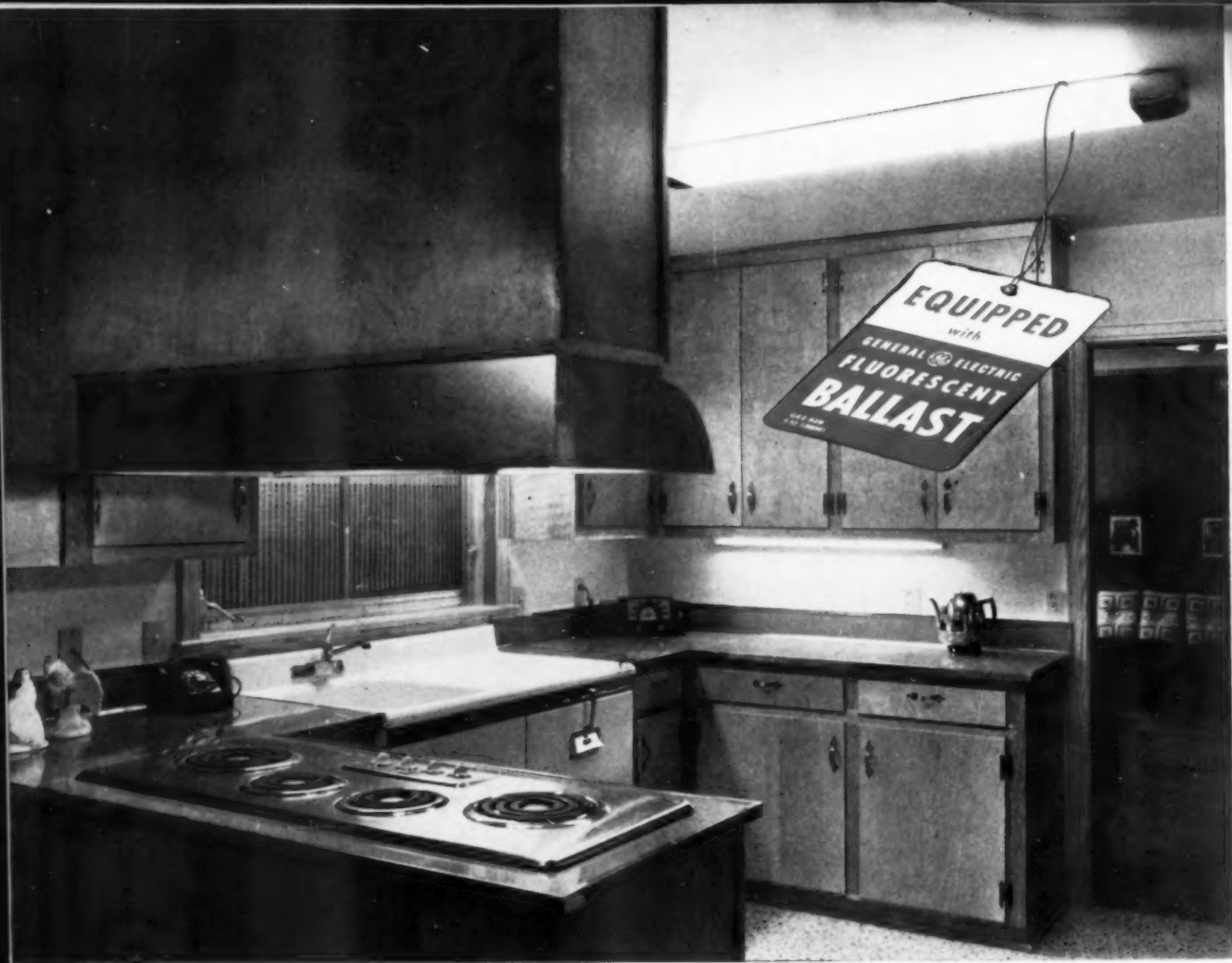

Modern Fluorescent Lighting with G-E Ballasts Adds "SELL" to Your House

Nothing sells your house faster than a modern, up-to-date kitchen. And for a few extra dollars, nothing sells a kitchen faster than the right type of lighting—plenty of *useful* light with a minimum of glare and shadows.

Attractive, soft, diffused fluorescent lighting in your house is one of its strongest sales appeals—especially to the feminine eye. And the key to good fluorescent lighting is a quality ballast—a G-E ballast.

Your customers know General Electric's reputation for dependability, value and quality. G-E ballasts assure

up to 50% longer lamp life, 30% higher light output and 50% longer ballast life.

Homeowners appreciate the more efficient lamp operation, increased light output and longer lamp life of home lighting fixtures equipped with *quiet* G-E ballasts. Make sure the fluorescent fixtures you buy are equipped with General Electric ballasts.

For further information send in the coupon at right . . . and specify fixtures displaying the . . . "Equipped with General Electric fluorescent ballast" tag. They add "SELL" to your house.

GENERAL  ELECTRIC

General Electric Company
Section 401-18
Schenectady 5, N. Y.

Please send me one of your four-color
bulletins, Wall Lighting Guide, GEA-6522.

NAME

ADDRESS

CITY

STATE



Tomorrow's House



They know what they want you to build . . . and how!

Houses built today will be homes for many tomorrows. That's what the 103 housewives at the Women's Congress on Housing had in mind when they told America's builders at the three-day session in Washington last April what they wanted—and didn't want—in a house.

At first greeted as a "coffee klatch with boondoggle yak-yak," the Congress came up with much sound unanimity on what modern family living requires. As Miss Annabelle Heath, assistant administrator of HHFA put it, "It is family living values that the women were talking about first and houses indirectly . . . Improvements in technology should be directed toward making the task that women have to perform in achieving these values easier, more convenient."

The ideas came directly out of practical circumstances, such as the prevalence of TV, full employment, scarcity of domestic help, more leisure. Builders who are trying to be ready for demand now have a useful guide for design.

Most important to a majority of the Congress was space, in preference to built-in appliances. This was

part of a general desire for individuality in decoration, exteriors, and landscaping.

INTERIORS. Layout of rooms got much thought. "Togetherness" and privacy must both be provided, for children as well as adults.

Family room should be next to kitchen, so Mother can supervise kids, enjoy television while preparing and serving meals. A sit-down table, not mere bar and stools, is wanted.

Living room should be out of traffic stream, always ready for formal guests, like old parlor. It can be smaller than is now common.

Kitchen should be at back of house, assuming rear play-yard, with view of yard and family room.

Mud room or decontamination area may be combined with toilet near kitchen to keep rest of house clean, prevent tracking of dirt through house. This is more important than a guest "powder room" at front.

Traffic should reach front door and bedrooms from kitchen-family area without crossing living room. "Halls and passageways are much easier to clean than a whole room."

Laundry should be near kitchen, in a separate small utility room if possible. Job can be done while preparing meals and watching children. If necessary to save cost, transfer laundry to less convenient basement or less desirable kitchen space.

Dining room, if possible, but at least an ell of living room.

Garage: two-car preferred, but garage is first to be eliminated to save cost. Connect storage space to garage or carport.

Bedrooms: three minimum, third finished as den if necessary. Closets in each; 5' long in master.

Baths: one complete plus half bath at kitchen; rounded corners, easy to clean; extra lavatory desired.

Basement: desired for storage and "to help keep house warmer."

LOCATION. Kitchen should face south, living room north so sun won't fade furniture. Picture windows, if the view is worth seeing.

EXTERIOR. No enthusiasm for fixed styles, whether Traditional or Contemporary. Wanted: design based on function; generally, pitched roofs with overhang; simplicity, but no row-house uniformity.

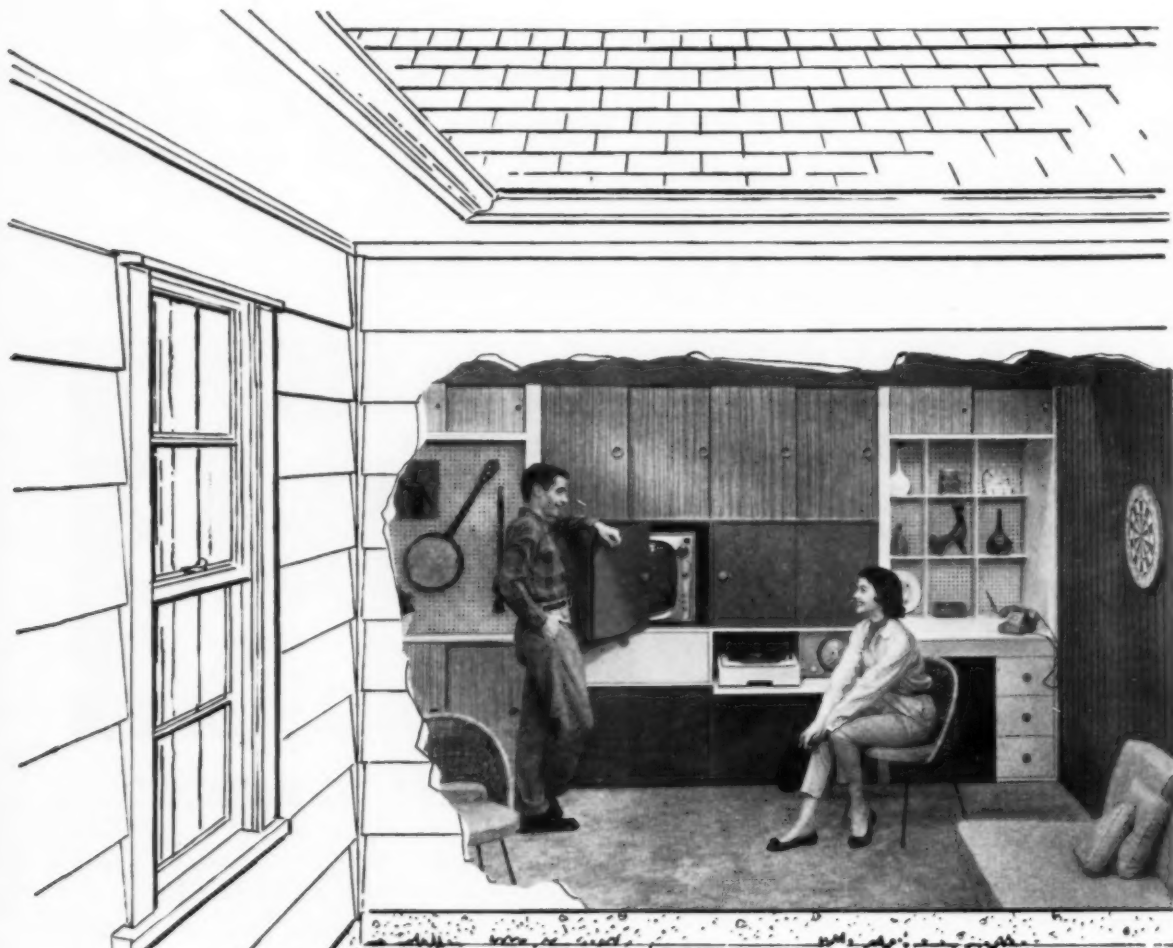

Growing houses thrive on Masonite panel products

—and now you're in the modernizing business! Or you're thinking about getting in. You've studied the picture: hundreds of small homes that need "add-ons" to give room to growing families...hundreds of older homes you could give a shot in the arm to.

It's an attractive picture when you include Masonite products, a complete family of sturdy hardboards...enough types, textures and thicknesses to meet every panel need. Varieties to create strong, durable walls, ceilings and cabinet-work inside the home (don't forget the exciting things you can do with Masonite[®] Peg-Board* panels and fixtures). And on the outside, revolutionary new Shadowvent[®] Siding, plus the other new textured panels that really upgrade a house.

Talk it over with your lumber dealer. Send the coupon for the complete story on these modern materials for modernizing. They pay off in profits!

Fix it up
inside and out



with Masonite products

© MASONITE CORPORATION
*Reg. T. M. U. S. Pat. Off., B. B. Butler Mfg. Co., Inc.

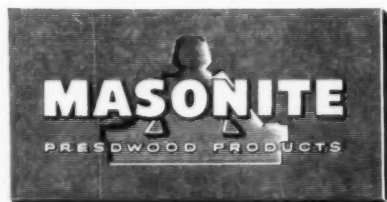

MASONITE CORPORATION
Dept. AB-7, Box 777, Chicago 90, Ill.

Please send me your Guide for Builders.

Name.....

Address.....

City..... State.....

Zone..... County.....

Biggest Name In Lighting Fixtures...



adds 2 more product lines

for Building Extras that build extra profits



**Complete Selection of
Ventilating
Range Hoods**

In introducing this new line of ventilating range hoods, Progress once more demonstrates unusual foresight in meeting growing demands for homemaking convenience. In removing kitchen fumes, regulating temperatures, these ventilating range hoods save on cleaning . . . bring added comfort to modern kitchens. Smartly designed by Progress to fit into any kitchen decor, they come in a choice of heat-resistant, fade-proof finishes; 4 sizes. Quality built, they're a sales-closing extra that means extra volume for you!

Full Line of Beautiful Door Chimes

Now Progress brings you a complete line-up of true toned door chimes tuned to wonderful home-maker acceptance! Handsomely styled assortment includes everything from the traditional to today's modern . . . from recessed electric clock chimes to repeating recessed door chimes. 20 styles, every wanted finish in this value-packed line. Typical Progress quality at rock-bottom prices assures PLUS-VALUE with these beautiful door chimes!

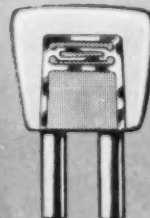
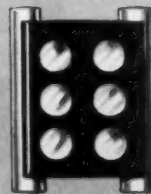
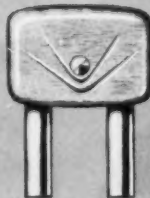
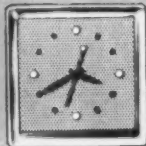
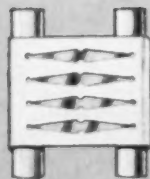

progress -the Top Line

highlighting more style, better engineering, more value in indoor and Outdoor Fixtures!

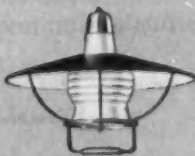

**Progress Manufacturing Company
Philadelphia 34, Pa.**



**PROGRESS
MANUFACTURING CO., INC.**

Castor Ave. & Tulip St., Philadelphia 34, Pa.

- Please send me information on entire Progress line
- Please have my Progress Distributor get in touch with me

NAME _____
 COMPANY _____
 ADDRESS _____
 CITY _____ ZONE _____ STATE _____

SMART WINDOWS---

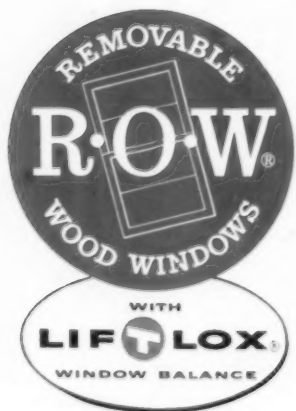
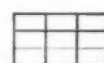

SMART WINDOWS—as measured by exacting modern standards—must be both beautiful and functional. For the beauty and insulation of wood—for easy operation and full removability—there's nothing like an R·O·W Window—always the leader and recently further improved by LIF-T-LOX.

R·O·W and Lif-T-Lox are the registered trade-marks of the R·O·W Sales Company

See your local lumber dealer or write

R·O·W SALES COMPANY, 1361 ACADEMY AVENUE, FERNDALE 20, MICHIGAN

FOR SMART WOMEN

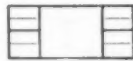

SMART WOMEN know that picture windows should be used *only* to frame a really desirable view. There is no substitute for adequate natural ventilation and reasonable privacy.

Cleaning and painting time is cut in half for the smart women who insist on R·O·W Windows.

See your local lumber dealer or write

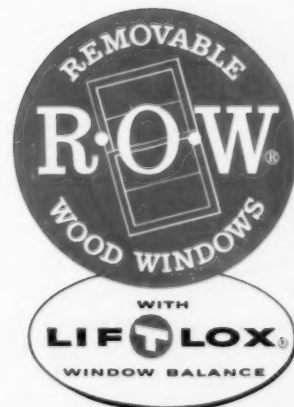

R·O·W and Lif-T-Lox are the registered trade-marks of the R·O·W Sales Company

R·O·W SALES COMPANY, 1361 ACADEMY AVENUE, FERDALE 20, MICHIGAN

JULY 1956

21

NOW! ONE SLIDING DOOR HARDWARE SET FITS ALL STANDARD DOORS... ANOTHER QUALITY LEIGH PRODUCT AT A MONEY-SAVING PRICE

NEW!

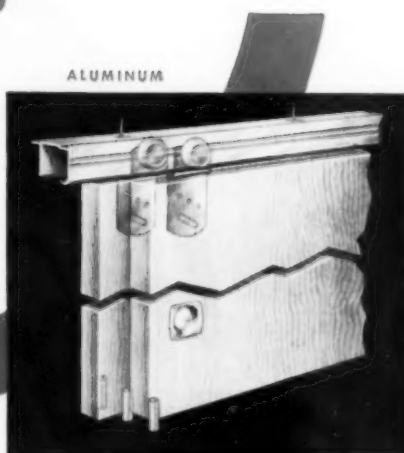

Leigh
SIZEOMATIC
SLIDING DOOR
HARDWARE

New LEIGH SizeOmatic Sliding Door Hardware Sets come with aluminum or electro-galvanized steel track. One package includes everything you need for a complete installation: track, nylon wheels, door pulls, and nylon door guides.

Here is the industry's only truly universal packaged door hardware. Identical sets fit all doors from 1/2" to 1 3/8" thickness... an exclusive feature of LEIGH SizeOmatic Sets. You save money when you buy them, save time when you install them.

NEW DESIGN

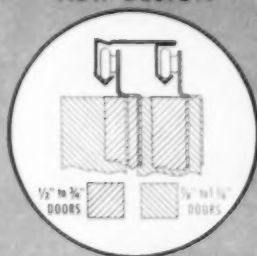

Unique track and reversible hanger construction fits 1/2" to 3/4" doors, reverses to fit 7/8" to 1 3/8" doors.

COST
LESS!

Cost and quality-conscious builders will appreciate the savings offered by LEIGH SizeOmatic Sets, available for 4', 5', 6' and 8' openings. See your Jobber today.

NEW PLASTIC GUIDE

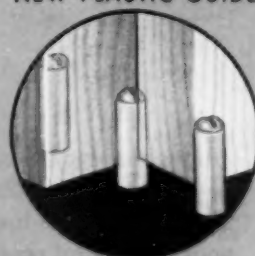

New Nylon door guides are simplest of all methods to hold doors firmly and gently in line for smooth, silent operation.



LEIGH BUILDING PRODUCTS DIV.
AIR CONTROL PRODUCTS, INC. Glass St., Coopersville, Mich.



PRESSTIME ROUNDUP

Buyers today mostly want "more space" . . .

Is more space the first consideration of families "shopping" today's new homes, as indicated recently by the HHFA-sponsored Women's Housing Congress at Washington?

Decidedly yes, was the verdict in an American Builder spot check of numerous cities over the nation, but many builders were quick to admit the high consumer acceptance of built-ins.

The inference is clear cut: that builders ingenious enough to provide some built-ins, as well as space, and keep within the price range of their market, have a definite edge in

the race for buyers during the remainder of the year.

"Of the 150 homes we build annually," reports Sidney B. Posin, partner in the Arbor Homes project at Waterbury, Conn., "the largest demand by buyers is for more space. Our average home has grown from 960 to 1,100-plus square feet.

"This demand seems to be translated into a desire for larger rooms or for an additional recreation area. "Our buyers love built-ins but will forego them for more space."

From Charlotte, N. C., the John Crosland Co. wires: "Our experience

is that buyers want more space such as extra rooms and an unfinished area, in place of built-ins. However, built-in ovens are very popular and are being used in one-third of our homes."

"Color use important—"

R. Gwynn Brock, Chattanooga, Tenn., finds that "extra space in bedrooms and kitchen, or family room, is preferred to built-ins; with increased utility or general storage space also important . . .

"Proper use of color is more important than built-ins."

. . . they also want built-ins and other "extras"

Preference for space in home planning is by no means universal. In Lake Charles, La., for example, H. L. Legros of Coastal Development Co., Inc., notes: "Buyers in this area are showing decided preference for built-ins and extra features. Larger rooms, extra space, etc., are apparently a secondary requirement."

"Wide variety—"

In Wilmington, Del., buyers in the moderate-price field where Franklin Builders Homes Inc., operates, prefer built-ins in wide variety.

This includes, says Henry L.

Weinstein, vice president, "air conditioning, oven and range, disposals, dishwashers, AW wiring, foyer flagstones, brick planters, fireplaces, outside barbecue pits and an outside patio."

"Buyers in the Detroit area," report David Kay Builders, "have been forced through various costs into a \$16,000 to \$20,000 bracket home and now require both space and built-ins such as ovens, dishwashers and other deluxe features, such as paneling, one and one-half baths, special paint and trim."

Moorestown, N. J., builder, Blase A. Ravikio believes the majority of

buyers who are following today's trend to larger families want more rooms and expandable space, rather than built-ins.

At the same time, he points out "small family groups demand built-ins, particularly in the kitchen area, where wall ovens are favored."

Built-ins, at a price—

Buyers in and near Atlantic City, N. J., points out William B. Blair of Highland Homes Inc., "would like more space in the low-price field, but once they have the space, in the higher-price field, they would like built-ins.

. . . but they'll settle, at a price, for space

"Buyers almost unanimously demand more space," says Marian G. Blake of Oakmont Inc., Richmond, Va.; "preferably separate dining room, larger utility room with washer-dryer space on ground level, more closet and storage space. They want more rooms and larger rooms, including a separate room for television and play space. Built-ins are not a prerequisite for selling."

Wanted: an extra room—

Strong among reasons for more space was the desirability of an extra

room: call it recreation room, playroom, TV room, family room, den.

From Mount Vernon, Ill., Earl D. Jamison reports: "Our buyers prefer more space such as a playroom in a basement or tri-level house. More storage space is also preferred."

C. Harry Swanson finds Indianapolis buyers also want an extra room: the recreation room.

Checking the Boston area, Alfred W. Halper of Newton Center, Mass., states that in the \$18,000 range, buyers prefer space first of all.

He says: "The TV den as a seventh

room is a must and can no longer be considered secondary space. Built-in cooking top and ovens have consumer acceptance but are not yet important selling features. Built-in refrigerators are rare in this area."

Larger rooms or no-down loans

In West Memphis, Ark., J. W. Rich finds buyers "want more space in the form of larger bedrooms and a full-sized dining room. However, we can still sell the house if a no-down payment loan is re-established."

What's ahead in the next six months?

News roundup based on reports from the NAHB spring meeting, trade and federal officials

HOUSING STARTS

Will they make a comeback?

With monthly figures running consistently behind 1955 totals, HHFA Administrator Albert M. Cole weakened a bit on his 1956 estimate. He said: "I believe we can have and will have 1,300,000 housing starts in 1956. It is desirable and still possible . . . but we can't achieve this total unless there is a significant increase in the flow of mortgage funds. It is the prime responsibility of private lenders to keep a steady flow of funds."

Starts this year will total between 1.1 and 1.2 million, predicts Walter H. Dreier, president of the United States Savings & Loan League. To build 1.3 million houses again this year, he said, "we could do it only at the price of a sharp inflationary upswing in building costs and prices."

The total will not now exceed 1.18 million, in the opinion of Joseph B. Haverstick, president, National Assn. of Home Builders. "It could be below one million," he warns, unless the Federal Reserve Board reverses its tight credit policy soon, and lower down payments and terms are made available.

FINANCING

Will it be easier? A few days later, there were signs FRB was taking steps to ease the financial brakes without reversing policy. Late in May, a sharp rise in uncollected checks moving through the banking system created a \$202 million rise in credit extended by FRB to the banks to cover the checks. Normally, it

would have sold some Treasury securities to "soak up" the extra funds, but this time it absorbed only \$70 million, resulting in an unexpected easing of the money market. Temporary, perhaps, but the Wall Street Journal reports "that the ease seems to be continuing."

National Savings & Loan League members will emphasize, this year, the financing of homes for moderate and lower-income families, according to Harold P. Braman, executive manager.

Advises USS&LL's Dreier: "Anyone planning to build a house in 1956 should do so in the expectation that mortgage terms during the remainder of the year will remain essentially the same as they are now."

TRADE-INS

Are more incentives on the way?

FHA gave a big boost to the trade-in program late in May and additional aid was indicated.

Previously, houses taken in trade had to undergo "major improvement"; now they need only meet FHA standards of soundness and livability.

Realty firms and land developers are now eligible for interim financing as well as builders; they can get an FHA-backed loan up to 85 per cent of the amount an owner-occupant can borrow on the same property. FHA Commissioner Norman P. Mason has expressed the hope that Congress will raise this to 90 per cent.

Maximum loan of this type will be \$17,000 for 20 years or three quarters of building's economic life. Previous limit was \$14,700.

Referring to builders and realty men, Mason said: "We're going to insist on a little faster approvals for existing homes so

you both won't lose a deal," by means of improved operations and added personnel. Traded-in houses which had FHA mortgage insurance approval prior to construction, he noted, would be eligible for more liberal financing than those lacking prior approval.

PUBLIC HOUSING

Is it on the rise again? The Senate has called for 135,000 units annually for at least three years, overriding by three votes an Administration measure limiting public housing to 35,000 units for each of the next two years. Final Congressional action, it is believed, will represent a compromise between these figures.

Concerning attempts to increase the PH tempo, NAHB president Haverstick said: "I can't understand why they expand the public housing program while putting brakes on private building."

NAHB is urging its local associations to conduct area-by-area surveys, checking existing income brackets eligible for admission against family income levels, average and lowest wage levels, what lowest level can afford to pay, number of homes now in area for rent at rates comparable with PH.

NAHB STAFF CHANGES

Neil J. Hardy, National Housing Center director, has been named to direct a long-range planning program for the industry. NAHB plans to engage a manager for some of Hardy's duties at NHC.

Burton C. Wood, former assistant to Rep. John Jarman, Oklahoma City, is NAHB's new assistant legislative director.

The association's community facilities department, now being formed, will be led by Frederick E. Wegner, engineer, city manager of Pleasant Ridge, Mich.

At this writing, it is believed that William A. Molster of the staff will head a new merchandising department.



Neil J. Hardy



Burton C. Wood

Kenneth S. Barry, former University of Maryland bursar, is the new comptroller.

VA LOAN PROGRAM

How much more time? GI loan program for World War II veterans, with one-year extension already having Senate approval is expected to be continued by Congress anywhere from one to four years.

NAHB, originally favoring a three-year extension, is urging careful study of bill introduced in the House by Rep. Olin Teague

of Texas, which favors an expanded FHA insurance program in place of an extended GI law.

Political observers familiar with operations "on the hill" believe Teague bill, comprising a major overhaul of housing legislation entered at the "11th hour," will not clear both houses this year; may be up for serious consideration in 1957.

COMMUNITY FACILITIES

How will builders meet this problem? NAHB directors acclaimed special showing of three NBC "Home" kinescope telecasts

featuring Arlene Francis interviewing experts to get to the root of several problems in the field. Sound films will be made available for use by all local associations.

MERCHANDISING

More emphasis on selling. Short course in merchandising sponsored by NAHB and the National Housing Center was held a second time in May, with section on trade-in selling added. Dates for third presentation are August 14-16.

DICKERMAN'S COLUMN

By John M. Dickerman, Executive Director, National Assn. of Home Builders

Builders worry over money, community facilities, land

From time to time the National Association of Home Builders conducts a spot survey of representative builders within its membership to tap the grass roots for trends and developments in the housing industry. The comments are refreshing and the information that is gathered is a highly useful adjunct to the all-too-limited housing statistics compiled by the Federal government.



Dickerman

Answers received from our last survey underscore the concern of builders throughout the country with the scarcity and high cost of mortgage money; with the ever growing problem of community facilities and rising land costs, and the other restrictions which are hampering the free enterprise of building good houses. Some builders are philosophic about the situation. The majority are not.

Although in months past I have discussed many of the problems on these pages, the comments of individual builders are particularly pertinent. Without identifying the builders by name, I'm setting out here aspects of the 1956 housing picture as they reported it from their own areas.

● "Ground asking prices have about doubled in the past year with improvement costs up about 50 per cent on the things they are requiring,

Money is now very tight and will stay that way for a while."—Eastern Pa.

● "City and county, FHA-VA and even the banks are constantly requiring more refinements in both house and lot. No one will deny these things are desirable, but they all cost money, and they are leading to a rash of loan rejects. Our buyers, being standard type humans, would like gold door knobs in their new homes—but not if it's going to run costs up or prevent qualifying for the loan."—Utah.

● "If the administration would permit FNMA to operate on a practical basis, it would permit funds to become available for home building and, at the same time, not result in loosening credit in other fields which might have inflationary tendency. It is not generally realized how much the mortgage situation has worsened. . . . The situation is critical."—Indiana.

● "Slow market today . . . Healthy in that it is weeding out poorly designed houses and locations. When this adjustment is complete the market will become healthy in the fall."—Texas.

● "The general picture is about the same as last year. Sales are satisfactory. We must reconcile ourselves to the fact that the picnic is over and the sooner the builder realizes that these are normal times the better off he will be."—Illinois.

● "Increased school taxes have retarded sales in suburban areas. We are now experiencing some diffi-

culty in getting acceptance of developments in towns where sewer facilities are unavailable. Land shortages have caused increase in costs and this problem is slowing up construction."—Upper New York State

● "VA and FHA forcing prices out of range of many families with their lot development requirements and construction requirements. Purchaser should be allowed to buy less (so long as it is sound) and receive benefit of VA guaranty or FHA insurance."—Mississippi.

● "Practically impossible to get any response to advance commitments. Market is tightest I've seen since 1953."—Tennessee.

● "Am building principally in the Negro market and without FNMA would be out of the market . . . There is no financing."—Texas.

● "Available financing in this area has never been difficult."—Conn.

● "As usual, money is available at a price."—South Florida.

● "In Florida, we must rely principally on out-of-state money due to insufficient home capital. These investors buy at the best market value—high discounts."—North Florida.

● "Mortgage money is the most pressing problem here."—Northern California.

And from Southern California comes the observation that the mortgage market is just "no good!"

These comments, I think, underscore the reasons why industry observers have revised downward their estimates for 1956 housing starts.

'Manny' Spiegel dies suddenly

Emanuel M. "Manny" Spiegel, who in 1953 served as one of the most popular presidents of the National Assn. of Home Builders, died suddenly June 15 of a heart attack at his home in Englewood, N. J.



E. M. Spiegel

His passing, at the age of 50, marked the loss of NAHB's first past president.

Spiegel, native New Yorker, entered the building business in 1941, after 13 years' of law practice. He helped organize the Home Builders Assn. of Northern New Jersey and the New Jersey Home Builders Assn. and served as president of each group. Prior to his tenure as NAHB president, he had been vice president and convention chairman. He had taken an active part in the NAHB's directors' spring meeting at Washington last May.

An exceedingly sincere and friendly man, "Manny" Spiegel guided NAHB through a crucial year in 1953. His eloquent arguments before many Congressional committees on behalf of the home building industry are credited with having much to do with easing of government housing loan facilities at that time.

At his death, he was secretary and director of the American Council to Improve Our Neighborhoods and a director of Housing Securities, Inc., New York. His best known project was the 400-unit Rutgers Village, recently completed at New Brunswick, N. J.

Plumbing industry scored and praised

Plumbing and bathrooms, which took a heavy beating at the recent HHFA-sponsored Women's Housing Congress, came in for a good deal of pro and con discussion at the fifth annual Building Research Institute meeting.

The meeting was held May 20-22 at Sheraton-Brock Hotel, Niagara Falls, Ont.

Richard B. Pollman, architectural designer and consultant, took the

plumbing industry to task for failing to provide builders with technically advanced design. Citing a need to cut plumbing costs, he called for simplification and standardization in the industry. He spoke of a need for a prefabricated wet wall unit and for baths designed on a modular plan.

Defending the plumbing manufacturers, John H. Zurn, vice president of the J. A. Zurn Mfg. Co., called attention to the great deal of research being done within the in-

dustry. Biggest drawback to progress, he noted, was due to state and local building codes.

Albert H. Morgan of the National Assn. of Plumbing Contractors said his organization favored bringing codes up to date, but noted that care should be taken not to relax sanitary standards.

A prediction that particle boards would replace solid core stock in doors and furniture in the near future was made by Carl A. Rishell.

(Continued on page 236)

DEALER'S VIEWPOINT

By H. R. Northup, Exec. Vice Pres., National Retail Lumber Dealers Assn.

Time plan a powerful sales aid

Four out of every five passenger cars and three out of every four large household appliances are sold on the installment plan, according to U. S. Department of Commerce figures. Yet, less than 20 per cent of materials sold by retail lumber yards are financed by the time payment plan.

That fact indicates rather clearly that most lumber dealers have not yet begun to make full use of this potent sales tool.

Even allowing for the fact that an important part of lumber dealer sales volume goes to contractors, it is still apparent that a surprisingly small percentage of consumer sales is being financed by a regular monthly payment plan.

Some dealers, of course, are making maximum use of installment selling, but most are doing little or no time payment business. When the latter group decides to go out after more consumer business, the job should be relatively easy if they adopt the methods being used so widely in other retail lines.

Phenomenal growth cited

The growth of installment selling since 1940 has been nothing short of astounding. At the end of that year all installment loans combined amounted to only \$5.5 billion. By the end of 1950, the total had climbed to \$14.5 billion, almost three times as much. Just four years later, at the end of 1954, installment

loans came to \$22.5 billion, a gain of more than 50 per cent. Then, by the end of 1955, the figure had jumped to \$27.9 billion, reflecting a gain of \$4.5 billion in just twelve months.

In other words, the gain in 1955 was almost as great as the total of all time payment loans at the end of 1940. The total amount outstanding in 1955 was five times as great as in the pre-war year. This helps to explain in part why sales were so high in some retail lines in 1955.

Time payment loans for repair and modernization have shown a gain too, from \$371 million at the end of 1940 to \$1.6 billion in December, 1955. But, that \$1.6 billion includes loans arranged by contractors, applicators and mail order concerns as well as retail lumber dealers.

Would aid OHI

Part of the increase in overall loans is due to using time payment selling in new fields such as travel, fire arms and photographic supplies. But the really big gains have come because so many automobiles, appliance and furniture dealers have promoted time payment selling to the limit.

The result is that many families already have their incomes pledged to such an extent for those other lines that they aren't eligible for further installment loans to finance home improvement jobs.

Nevertheless, aggressive promotion by lumber dealers would bring in a lot of extra business from families that need to improve their homes.



Northup

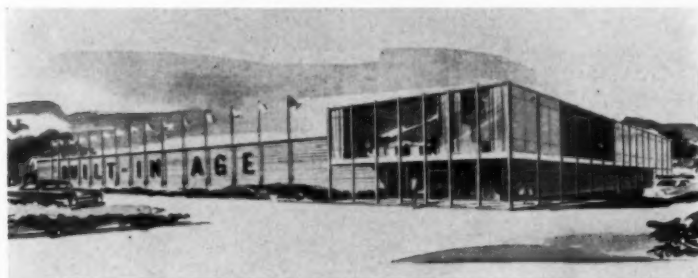

PERMANENT EXHIBIT HALL for new designs, materials and appliances

planned for fall opening on a major highway in Mountainside, N. J.

Pick highway site for home center

New Jersey's first building for "permanent" display of construction materials, appliances and designs, breaks away from the usual trend to locate such display centers in or near the center of large metropolitan areas. "Built-in-Age," as it is called by the sponsors, Charles S. Cohan and Ralph Brass, is scheduled to open this fall in Mountainside, N. J., on a major highway near its junction with a state parkway.

The structure, designed by Herman C. Litwack of the Architects Group of Newark, contains over 27,500 square feet of exhibition space and is estimated to cost \$1,000,000. In addition to displays, it will have a reference library, and a workshop with drafting tables and equipment for use of architects and others who wish to "put on paper" any new ideas they see displayed. A trained staff is to be on hand to assist professional or amateur visitors.

Upgrade zoning to 4-acre lots

New Canaan, Conn., zoning commission has ordered the minimum lot size in an estimated 4,400 acres of the township upgraded from two to four acres as its latest move in a series of progressively tightened restrictions. Its decision came two days after negotiations were announced for sale of 430 acres to a developer.

The action was also said to affect a 133-acre tract on which Blitz & Price, Norwalk developers, had previously filed a subdivision application. The commission had given approval conditioned to the builders' willingness to increase the minimum lot size from two to three acres. Its authority to demand this condition is being challenged in court.

Wage settlements in the building

trades continue to reach new highs and add to housing costs. Two-year agreement in the Greater New York area and part of Long Island boosts scale for bricklayers 25 cents to \$4.05 an hour. After Jan. 1, 1957, the rate will be \$4.25.

In Cleveland, a 17-day strike of 14 unions ended with a 17½-cent per hour increase now, 16½-cent additional rise effective May 1, 1957. Among the new hourly rates are: bricklayers, \$3.65; carpenters, ironworkers, cement workers, roofers and lathers, \$3.57½.

\$2,000,000 'American beauty'

Higher costs notwithstanding, 8,000 persons turned out on a rainy weekend in the Detroit area to see the new American Beauty luxury split-level model opened by Charles Levin and Les Taubman (American Community Builders). Miss America of 1955, Lee Ann Meriwether, participated in the ceremony opening a 150-unit project. After two, very wet days, half the development was sold for more than \$2,000,000.

Herbert Sadkin and Norman Adolf recently opened their newest Birchwood colony on Long Island, offering 500 ranches and "splits" at Plainview, N. Y., for \$17,990 to \$21,990. They recorded 82 sales the first weekend, with many buyers attracted by a \$1,000 extra: a complete air conditioning installation.

Norman K. Winston and David Muss, New York builders who marked National Home Week last fall by selling the first 300 units of their Melrose Park, Ill., project in 48 hours, put a final 600 houses on the line this spring. Despite higher prices, they obtained 427 more buyers in two days.

To the list of unusual model names, add that of the "Automatic '57," a \$25,000 model introduced late in May by Ballin, Langfur & Glicksman in their 500-house Ocean-side, N. Y., project. It's a four-bedroom "split" offering several automatic features including underground sprinklers, garage door openers, fire alarm detectors, radio-intercom system, remote control wiring, two-zone heat.

Builders donate facilities

Among several builders who have acted to improve their community relationship are:

- Segal Construction Co., which is building a six-classroom, octagon-shaped school and will donate it with a 12-acre site to Madison Township, N. J., this fall. The firm is constructing 600 homes in the area.

- Huber Construction Co., donating 16 acres as a permanent school site and making available up to 35 brick homes for temporary use as classrooms to Wayne Township, near Dayton, Ohio. The homes, part of 2,000-unit Huber Heights, will be built without partitions and leased at \$1 a year. After permanent facilities are built, the units will be returned to Huber, who will complete them as homes.

- Suburban Park Village, 750-home project at Baldwinsville, N. Y., which has announced it will deed five playground sites to the village.

- St. Paul HBA, Builders Exchange, carpenters' union and millwork dealers, who donated material and labor to build one-room log school for St. Paul, Minn., public school centennial celebration. It was a replica of city's first school.



FOR BEST SUGGESTIONS by building department workers, Chicago Metropolitan HBA offers monthly awards. John Downs (left), HBA executive vice president, and George Ramsey, building commissioner, are shown here with recent winners: John Jura-vich, Ben Odes, Raymond Godlove.

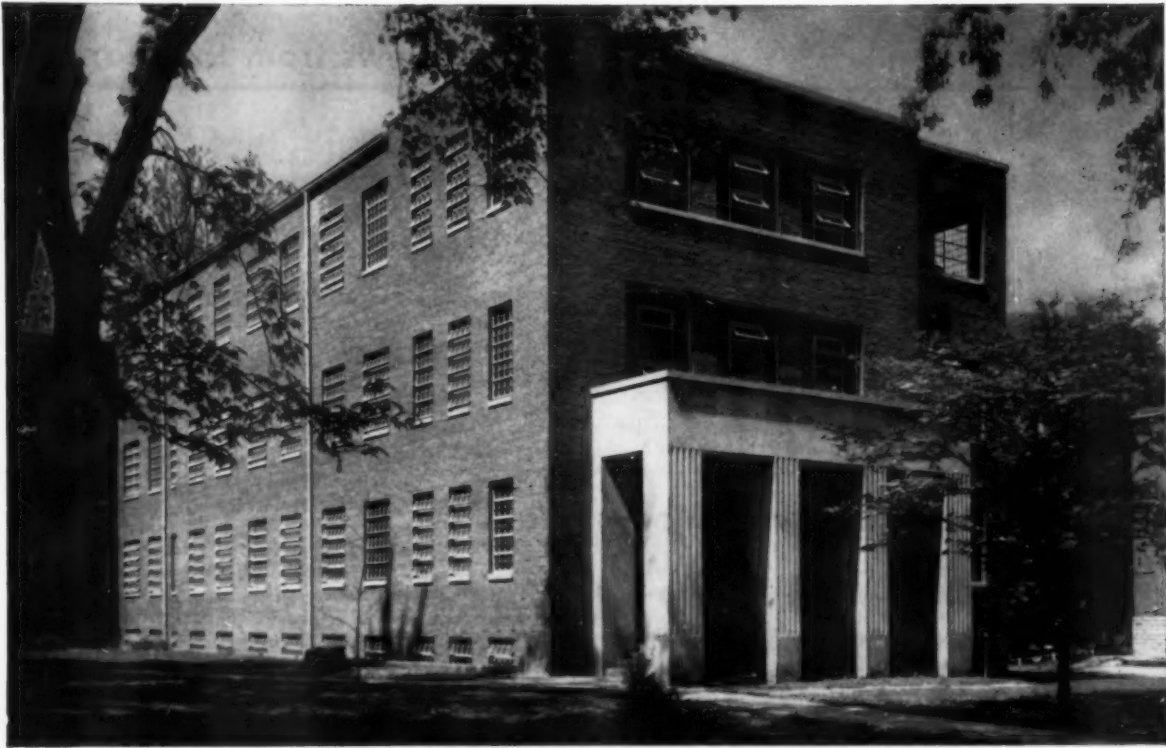

Central State Hospital, Lakeland, Ky. Contractor: Whittenberg Construction Co. Architect: Fred J. Hartstern.

PLENTY OF SUNLIGHT AND FRESH AIR IN THIS MODERN MENTAL HOSPITAL

....Thanks to Steel Windows

Nowadays the designers of detention-type institutions like this mental hospital realize the importance of natural daylight and ventilation for inmate morale and rehabilitation. It follows that they specify steel windows, because only steel framing members can be made strong enough to insure security, yet slender enough to permit an abundance of sunlight and fresh air.

Whether you're building hospitals or homes, you'll find that slender-framed steel windows give the most light, visibility and ventilation. Yet they're rugged enough to withstand the unavoidable knocks they often get during shipment, at the job site, and during year after year of service in the finished building.

In addition, you save money two ways with steel windows: (1) they cost less than most other types, and (2) they usually cost less to install, because they come factory-assembled (with steel casing, if desired) for quick, easy installation. Your local building supply dealers stock many popular types of steel windows, including residential casements, ranch windows and window-walls.

For many years, manufacturers of quality steel windows have used solid, hot-rolled sections of open-hearth steel produced by Bethlehem.

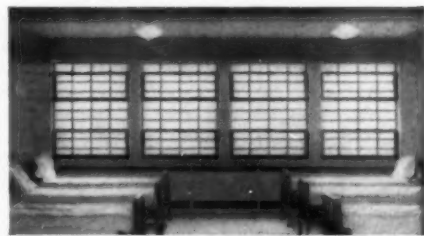

SUNNY INFIRMARY—The slender steel bars of these psychiatric windows help keep this criminal men's infirmary bright and sunny, but provide a high degree of security. For information about steel windows for detention institutions, industrial and commercial buildings, and residential construction, contact the local representative of any manufacturer of steel windows, or see Sweet's File 16b.

BETHLEHEM STEEL COMPANY
BETHLEHEM, PA.

On the Pacific Coast Bethlehem products are sold by Bethlehem Pacific Coast Steel Corporation. Export Distributor: Bethlehem Steel Export Corporation

BUILD FASTER...SELL FASTER WITH

STEEL WINDOWS



Clipper

SAWS RIGHT THRU

MASONRY SAW

• The SAW That
Cuts Faster —
SMOOTHER —
Makes Blades
LAST LONGER!

Cut in 5



Seconds with CLIPPER

... and Only Clipper
Patented Features
assure this
performance

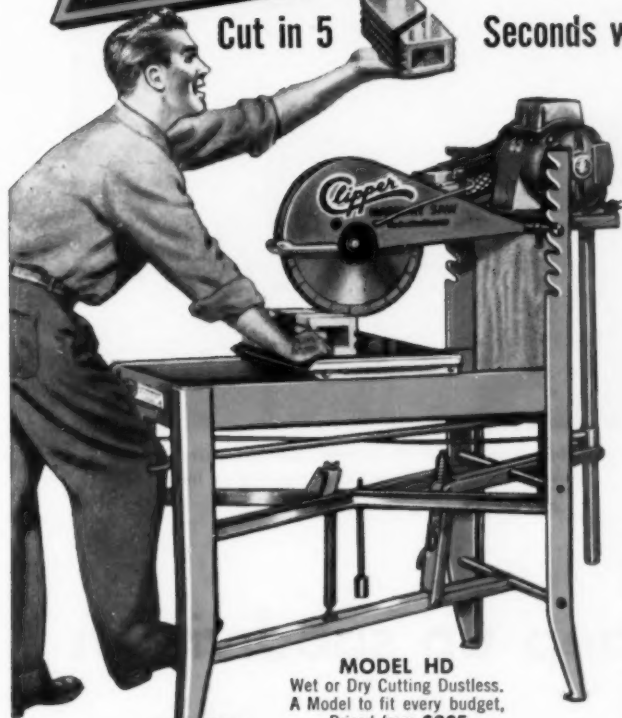

MODEL HD
Wet or Dry Cutting Dustless.
A Model to fit every budget,
Priced from \$265

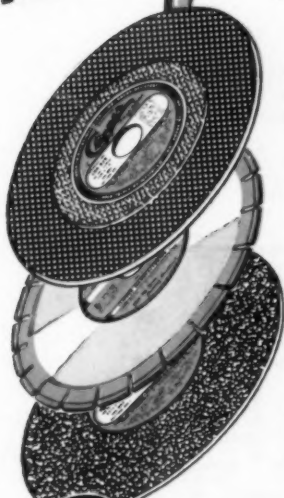

CLIPPER BLADES

• BREAK RESISTANT

Triple Reinforced . . . in specifications to cut every masonry material . . . HARD to SOFT. Another Clipper First! Polk-A-Dot design reduces side friction, delivers maximum power to cutting edge. Break-Resistant—Safer—Lower Cost.

• DIAMOND

Clipper sells more because Clipper sells Quality. Blade after blade, on tile to block, Clipper Diamond Blades outperform, outcut and outlast any other blade. Dependable . . . consistent quality.

• ABRASIVES, Wet or Dry

Hard . . . Soft . . . Porous . . . Dense, Wet or Dry there's a special Clipper Abrasive Blade to cut any masonry material faster, better with guaranteed lower costs. Clipper quality is your Best Buy.



MANUFACTURING CO., KANSAS CITY 8, MO.

Sold Only Direct by Factory Trained Representatives
From Factory Branches in Principal Cities—Coast to Coast.

Not Just a NOTCH
A Deep Seating NOTCH!

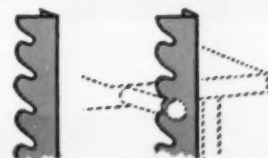

SELECT-A-NOTCH (patented). It's easy for one man to adjust cutting head—to desired height for cutting any size material. Weight of head is supported by connecting bar. Clipper's deep seating notches always guarantee true cutting head alignment—assure maximum blade life and increased production.

MAIL COUPON FOR FACTS

CLIPPER MANUFACTURING CO.
2808SW Warwick • Kansas City 8, Mo. 209X

- | | |
|---|--|
| <input type="checkbox"/> I want a Clipper Masonry Saw on FREE TRIAL. | <input type="checkbox"/> Send FREE Literature on Clipper Concrete Saws and Blades. |
| <input type="checkbox"/> Send FREE Literature on Clipper Masonry Saws and Blades. | <input type="checkbox"/> Have a Clipper factory trained representative call on me. |

NAME _____

ADDRESS _____

CITY _____

STATE _____

MAIL COUPON TODAY!

FREE TRIAL

You be the judge—try this new Clipper FREE on your job. The outstanding policy of Free Trial has been in effect since Clipper invented the World's First Masonry Saw nearly 20 years ago.

CLIPPER IS CONVERTIBLE

• LIGHT DUTY CONCRETE SAW

Cut Machinery Bases,
Repair patch walks
and driveways

TRACK SAWS

Cut Transit Sheets,
Stone and Refractory
Slabs and Other
Large Materials.

Not Just a SPRING A Pressure Equalizer SPRING

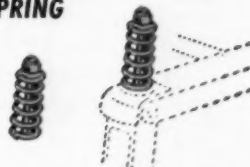

Makes your blades last longer . . . because Equalizer Spring automatically cushions blade pressure, whether cutting hard or soft materials. Guarantees faster cutting — with longest blade life.

Not Just a PUMP A WET or DRY PUMP

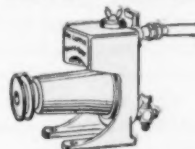

Clipper's Sealed Water Pump needs no extra motor—no electrical connections. Permanently attached to eliminate piferage. Always adequate water to preserve blade life—control DUST. Never too much to soak material or drown operator. Just turn valve—no need to remove belt when cutting dry.

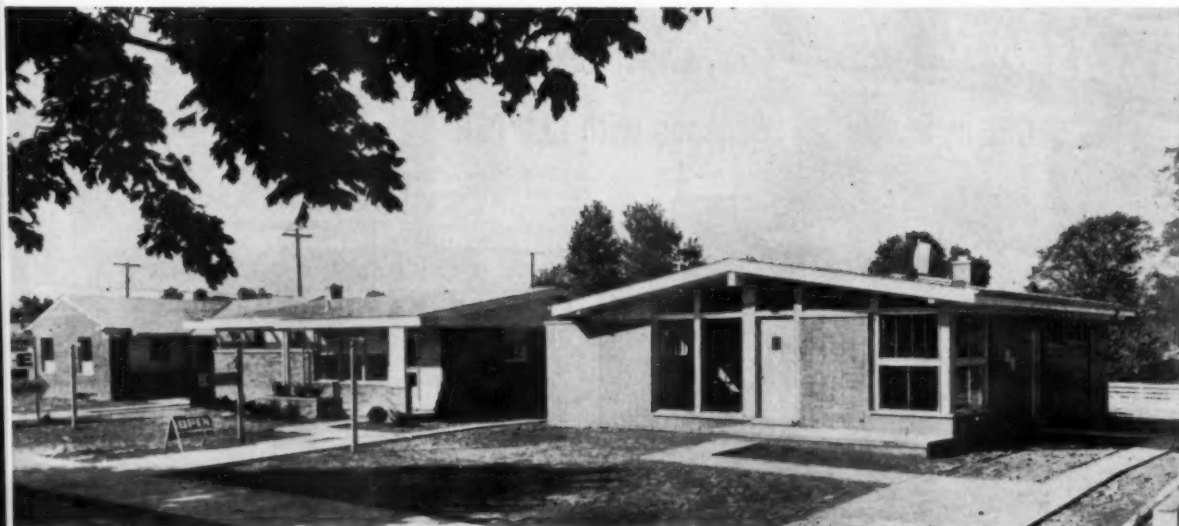

PRICED AT \$16,300, contemporary model, right, is newest Rose design. Model is located in St. Clair Shores in sub-

urban Detroit, one of eight subdivisions currently bearing Rose trademark. Rose is "dean" of Detroit builders.

How to pep up subdivision

To root reluctant Detroit buyers out in the open, big time builder Edward Rose & Sons is offering these three plans plus 13 "distinctive and different" elevations. To this he's adding 30-year terms, a year's service guarantee in writing and a surefire trade-in plan. The latter has been chosen for national awards as one of the six best trade-in plans in the country.

Here are some of the features that Rose is promoting in these houses: oversized entrance "guestibles," paneled dens, perimeter forced air gas heat, corner jalousie windows in the kitchen and six-foot sliding windows (Alwintite) in the basement.

Rose is also one of the few builders in the Detroit area with enough experience and know-how (34 years) to market a four-bedroom house for under \$18,000, including lot.

CONTEMPORARY MODEL has studio ceilings, 1½ baths and over 1,100 square feet of area. Rose boasts no skimping of ceramic tile in baths, which covers floor and half of walls. Like other models this one has full basement.



the MONTH for July



FOUR-BEDROOM MODEL, above, designed by Beneicke & Lorenz is one of Rose's best sellers. Also popular is three

bedroom model at right, which features oversized basement window and bathroom mirror and face brick.

sales ...

IT'S LOADED—WITH SPACE



FOR THIS POPULAR PLAN buyers pay \$16,300—get 1,093 square feet of space in return. For the most part, house is dry wall with wood cabinets in the kitchen. Another Rose extra: provision for future toilet in basement.

BIG THREE BEDROOM, two bath model gives buyer what he usually wants more than almost anything else—precious space. Plan has 1,271 square feet of it. All Rose sub-divisions have curvilinear streets for safety's sake.

**THE FINEST
for today's
NEW kitchen look!**



TRADE-WIND SALEM VENTILATING HOOD

It's Trade-Wind's striking, efficient new early American Ventilating Hood.

... Striking in design with the hand-craftsman look in rich antique copper to match the latest ranges.

... Efficient in performance with the exclusive Trade-Wind baffle which evenly distributes the discharge for front or back burner use.

Made of Trade-Wind's own Duomett, a laminated sheet of solid copper and steel for beauty and permanence. The hood is available in five standard lengths. It can be used with any of the 3 powerful Trade-Wind Ventilators illustrated below.



3901 — Ventilator.
890 CFM.
2 inlets and filters, 4-speed switch.



2901 — Ventilator.
425 CFM.
Filter available, 4-speed switch.



1901 — Ventilator.
300 CFM.
Filter and 4-speed switch available.

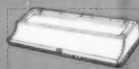

SALEM HOOD —
In antique copper to match latest range tops, 36", 38", 39", 42" and 48" lengths.



EXPANSION HOOD — Copper or stainless steel in 2 sizes which adjust from 36" to 42" and 42" to 54".

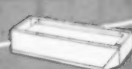

STATIONARY HOOD — Copper or stainless steel in 36", 38", 39", 42" and 48" lengths.

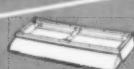

FOLD-UNDER HOOD — Stainless steel only, 36" and 42" lengths.

MOST COMPLETE LINE OF HOODS AND VENTILATORS

Trade-Wind Motorfans, Inc. 7755 PARAMOUNT BLVD., DEPT. AB, RIVERA, CALIF.



Color Comes To The Kitchen with Customline Appliances. Make your choice from gleaming stainless finish, Coppertone and five new Colortones: Sunburst Yellow, Coral Pink, Meadow Green, Woodland Brown and Seafoam Blue.

COMPARE BUILT-INS AND YOU'LL SEE

Hotpoint OFFERS

GREATER VARIETY, FEATURES, PROFITS!

HERE ARE THE FACTS . . .

	Hotpoint	Major Brand "A"	Major Brand "B"	Major Brand "C"
OVENS				
Number of Models	5	2	1	2
Double-oven model	Yes	No	No	No
Rotisserie	Yes	No	Yes	No
Pushbutton Controls	Yes	No	No	No
Window in door	Yes	No	No	Yes
SURFACE UNITS				
Number of Models	5	2	2	3
Pushbutton Controls	Yes	Yes	No	No
Faster-than-gas unit	Yes	Yes	No	No
Deep-well cooker	Yes	No	No	No
Plug-in French Fryer	Yes	No	No	No

All built-ins aren't alike! A comparison of Hotpoint Built-In Ranges with those of the other 3 leading appliance manufacturers shows that Hotpoint offers you **more models** to choose from—**more features** to help you sell your homes. And, Hotpoint offers comparable superiority in built-in refrigerator-freezers and dishwashers as well.

It costs you no more to enjoy the extra sales appeal of these superior appliances, because Hotpoint wants builder business and has the prices to get it! And, with Hotpoint Customline, you also enjoy all these additional advantages:

- **Finest quality**
- **Fast, low-cost installation**
- **High consumer acceptance**
- **Powerful national advertising**
- **Strong local merchandising**
- **Top appraisal value**
- **Kitchen design service**

Whether you're building \$10,000 or \$100,000 homes, you'll find the right models for your market in Hotpoint's complete line. They'll help you sell your homes faster and at greater profit. Contact your Hotpoint Distributor's BUILDER SPECIALIST today!

look to Hotpoint

for the finest...first!



Hotpoint 9-foot Modular Kitchen with high oven. Color is Sunburst Yellow.

they're here! Dramatic

new Hotpoint modular kitchens

**THE APPLIANCES OF THE FUTURE
TO HELP SELL YOUR HOMES TODAY!**

9 FEET OF GLEAMING
PUSHBUTTON LUXURY—

- ★ Deluxe Super Oven with Roti-Grill Rotisserie.
- ★ 4 Calrod® Surface Cooking Units, including reliable automatic unit under deep-well cooker.
- ★ Automatically-controlled Plug-in Griddle.
- ★ Deluxe pushbutton Dishwasher.
- ★ Disposal® Food Waste Disposer (optional).
- ★ Seamless, stainless steel countertop and sink with Wonderflo single-control faucet.
- ★ Pushbutton controls and appliance outlets.
- ★ Roomy storage cabinets and drawers.

Choice of LEFT-HAND or RIGHT-HAND MODELS



Available with cooking center at left or right end of unit at no extra cost. Provides greater planning freedom, enables you to reverse floor plans.





WITH HOME BUYERS

IT'S LOVE AT FIRST SIGHT



Hotpoint 7-foot Modular Kitchen with under counter oven. Color is Coral Pink.

Hotpoint 7-foot Modular Kitchen with separate wall oven. Color is Meadow Green.



IN ONE COMPACT UNIT—A COMPLETE MEAL PREPARATION *and* CLEAN-UP CENTER

Your homes will be "the talk of the town" with these exciting new Hotpoint Modular Kitchens. Women lose their hearts when they see the handsome combination of colored, pushbutton appliances and gleaming stainless steel countertop.

Distinctive and beautiful, compact and efficient, these units are the newest development in kitchens—and the hottest sales feature your homes can offer.

You'll like the way Hotpoint Modular Kitchens have been designed for fast, low-cost installation with normal skills and materials—no tricky hook-ups to cause expensive

on-site slow-ups. And, these compact new units save floor space, while giving you complete freedom to plan kitchens that offer a new high in styling and convenience.

Hotpoint Modular Kitchens can be included on the mortgage for only a few dollars a month. They're available in 5 beautiful Colortones—Sunburst Yellow, Coral Pink, Meadow Green, Woodland Brown, and Sea-foam Blue.

Be the first builder in your community to capitalize on this great new home selling feature. Contact your Hotpoint Distributor's BUILDER SPECIALIST today!

Look to Hotpoint for the finest...first!

Exclusive Hotpoint Spot-Less Dishwashing

SELLS HOMES FASTER—

Outmodes All Other Dishwashing Methods



● **Your prospects are PRE-SOLD on Hotpoint Spot-Less Dishwashing**—by consistent, hard-hitting NATIONAL ADVERTISING!

The story of Hotpoint Spot-Less Dishwashing is being told in big, 4-color ads in national magazines—and by dramatic demonstrations on television! When women see the Hotpoint Dishwasher, they know they're getting fine equipment and a fine home.

● **Your prospects are PRE-SOLD** by confidence-building IMPARTIAL RECOMMENDATIONS!

The Hotpoint Dishwasher is the **ONLY Automatic Dishwasher recommended in the last 4 years by one of the nation's leading consumer research organizations!** And it has been consistently featured in editorial articles appearing in leading consumer magazines.

● **Your prospects are PRE-SOLD** by Hotpoint's unequalled PERFORMANCE and FEATURES!

Women want Hotpoint's wonderful work-saving features like pushbutton control and separate Roll-R-Racks. Consumer surveys prove conclusively that **homemakers prefer Hotpoint's separate Roll-R-Racks 4½ to 1 over competitors' pull-out-tubs!**

● **Hotpoint Dishwashers are easy to install**—Both drain and hot water connections can be made from the front, with gravity or pump-drain Dishwasher in place.

Available in 5 Colortones, Coppertone, or Customline Satin-Chrome Finish. Capitalize on the terrific "home selling" appeal of Hotpoint Dishwashers! Contact your Hotpoint Distributor's BUILDER SPECIALIST for the story.



Exclusive Spot-Less Dishwashing

Women are sold on this wonderful dishwashing method. Two 5-minute Spot-Less washes—with fresh detergent each time—scrub away every trace of food and film. Spot-Less second rinse eliminates spots on glass and silver! Super wetting agent is injected in second rinse—water spreads so smoothly, it can't form drops, can't dry as spots.

Your eyes tell you! Spotted glass (left) was rinsed in plain water. Sparkling glass (right) was rinsed the new Hotpoint Spot-Less way.

Look to Hotpoint for the finest...first!



For driveways . . .

YOU CAN'T BEAT REINFORCED CONCRETE!

America is buying bigger homes, better homes. You will be building some of them. You'll want to see that every last detail spells economy and "quality."

That goes for concrete surfaces, too. For strength and durability—*long-lasting* good looks—be sure to reinforce every concrete surface with American Welded Wire Fabric. Not only driveways, but porches, patios, sidewalks, slab floors, curbs, foundation walls as well.

American Welded Wire Fabric adds the strength of steel to your concrete . . . binds the whole slab tightly together . . . stops bad cracks. It costs less to build a reinforced concrete slab because concrete ground slabs reinforced with American Welded Wire Fabric are approximately 30% stronger than an unreinforced slab of equal thickness. There's a type and size of American Welded Wire Fabric for every job.

AMERICAN STEEL & WIRE DIVISION

UNITED STATES STEEL, GENERAL OFFICES: CLEVELAND, OHIO

COLUMBIA-GENEVA STEEL DIVISION, SAN FRANCISCO, PACIFIC COAST DISTRIBUTORS
TENNESSEE COAL & IRON DIVISION, FAIRFIELD, ALA., SOUTHERN DISTRIBUTORS
UNITED STATES STEEL EXPORT COMPANY, NEW YORK

EVERY TYPE OF REINFORCED CONCRETE CONSTRUCTION NEEDS

USS AMERICAN WELDED WIRE FABRIC

UNITED STATES STEEL

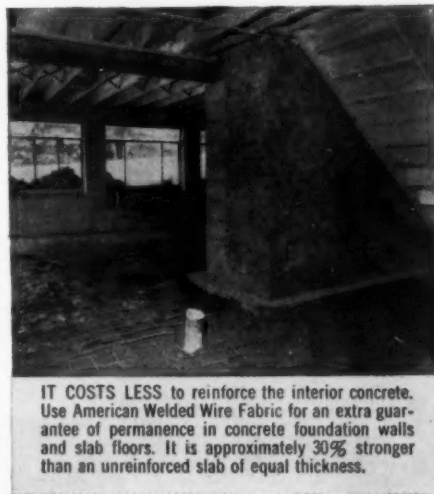

IT COSTS LESS to reinforce the interior concrete. Use American Welded Wire Fabric for an extra guarantee of permanence in concrete foundation walls and slab floors. It is approximately 30% stronger than an unreinforced slab of equal thickness.

*BUYERS WILL ASK
"is it Reinforced"*





CALKING &

GOIN' GREAT GUNS



The "Original" CALKING LOAD

Dressed up in a

BRIGHT NEW LABEL!

Here's the fastest way to calk cracks around windows and doors. M-D SPEED LOADS are available in Off-White or Pure White Color. Also available with or without Plastic Nozzle. Off-White Load shipped without nozzle unless specified. Meets Federal Specifications TT-C-598 (Grade 1).

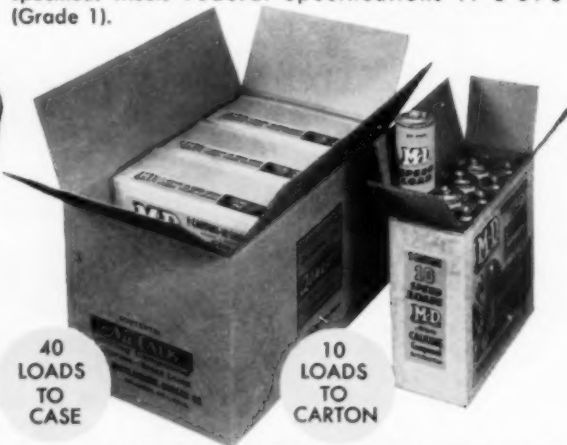

Packed 10 SPEED LOADS to a carton or in cases of 40 loads.

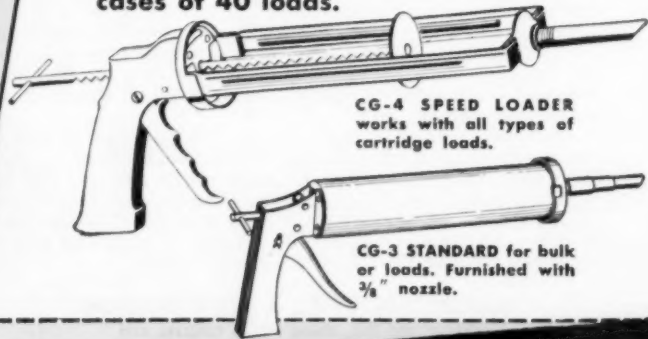

CG-4 SPEED LOADER works with all types of cartridge loads.

CG-3 STANDARD for bulk or loads. Furnished with 3/8" nozzle.

MACKLANBURG-DUNCAN CO.

OKLAHOMA CITY 1, OKLAHOMA

MACKLANBURG
DUNCAN CO.
MANUFACTURER OF
QUALITY
BUILDING
SPECIALTIES

GLAZING COMPOUNDS

with **BUILDERS** and **DEALERS**

HAND SQUEEZE TUBES

for small jobs

No gun needed. Simply remove cap from built-in nozzle, fasten key over crimped end, turn key and start calking. Here's a fast-moving item for over-the-counter sales. Packed 12 tubes in a handsome "Silent Salesman" display carton that can be quickly set up on your counter.



Nu-CALK CALKING COMPOUND

in Bulk—Knife or Gun Grade

Off-White Color available in knife grade or gun grade. Pure White Color available in gun grade only. Off-White shipped unless White specified. Gun grade meets Federal Specifications No. TT-C-598 (Grade 1). Available in 1/2 pt., pt., qt., gallon, 5 gal. and 55 gals.



Nu-Glaze GLAZING COMPOUND

Always stays "PUT"

Here's the perfect material for glazing wood or metal sash, replacing putty, setting plumbing, filling cracks, boatwork of all kinds. Clean to handle, easy to use. Will not dry out, harden, crack or peel. Available in 1/2 pt., pt. and qt. cans; 25, 50, 100, 880 lb. drums.



Nu-Phalt PLASTIC

ASPHALT CEMENT for all jobs!

Ideal for sticking down asphalt shingles and floor tiles . . . for use on roofs, chimneys, flashings. Packed 10 loads to a carton . . . with or without plastic nozzle. Shipped without nozzle unless specified. Also available in 2 1/2 and 10 lb. cans; 50 lb. pails; 550 lb. drums.



DEALERS
ORDER TODAY—your order will
receive prompt shipment!

BUILDERS!
Sold by all Hardware, Lumber
and Building Supply Dealers

YOU FEATURE THESE THREE

QUICK INSTALLATION
ABUNDANT HEAT
FAST SALES

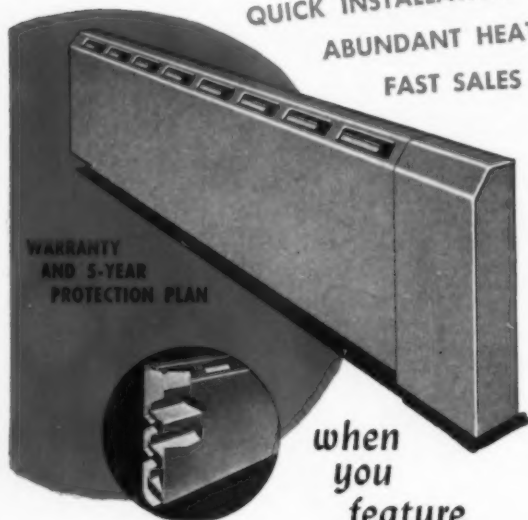

WARRANTY
AND 5-YEAR
PROTECTION PLAN

when
you
feature

TRIMRAD KOVEN

baseboard radiators

Whether you're looking for fast sales, abundant heat, or quick installation, you'll find all three in KOVEN Trimrad, the 2-way baseboard radiator that's efficiently engineered to fit side by side with regular radiators—that maintains the finest standards in service—and whose new

higher ratings assure more long-lasting trouble-free performance than ever before. And Trimrad's quick installation helps save valuable on-the-job time as well. So take our tip and start bettering your sales record now. Order KOVEN Trimrad TODAY.

NATIONALLY
ADVERTISED



CHECK FOR NEW
HIGHER RATINGS

MORE HEAT BY RADIATION
30% convected heat
30% radiated heat

ALMOST INVISIBLE
Practically flush
with the wall

- 3 BIG WATERWAYS back front panel — hold more water, store and emit heat longer
- LIGHTWEIGHT — one man can handle longest length
- MILL-ROLLED WELDED STEEL gives maximum heat conductivity
- NO FINS TO CLEAN or get clogged with dust
- UNIFORM HEAT from floor to ceiling
- NO DRAFTS OR COLD POCKETS
- FOR NEW OR OLD WORK



HEALTHY HOT WATER HEAT
WATERFILM BOILERS, INC.

PLANTS: Jersey City, N. J.
Dover, N. J.
Trenton, N. J.

• division of L. O. KOVEN & BRO., INC.

154 Ogden Ave., Jersey City 7, N. J.

KEES GALVANIZED METAL BUILDING CORNERS *Made for the Job!*

There's a Kees building corner made especially for the job, whether the construction is of wood or of hardboard siding.

Corner
for
hardboard
construction



Two corners
for
typical wood
construction



Made of 28 gauge zinc coated steel, Kees corners make possible that "mitered look" without the slow, expensive work of cutting and fitting the ends of the siding. Metal corner is unnoticed after building is painted.

Lower flanges overlap and make tight joints. Joints can't pull part, and moisture can't rot the corner because it is completely covered.

Sizes and patterns available for all widths and thicknesses of lap siding and various patterns of drop siding, in addition to sizes made especially for hardboard.

ORDER FROM YOUR JOBBER

Write P.O. Box 598 for Free Catalog

"Since 1874"



F. D. KEES MFG. CO.
BEATRICE NEBRASKA

THIMBLE MAGIC...



A New Kind of Louver

... the Midget Thimble lets air into places no other louver can reach, protects paint, wood and metal from excess heat and moisture.

Thimble Louvers are always used with regular Midget Louvers, feature same easy push-in installation, hold securely without nails or screws. Perforated design is insectproof, won't clog when painted.

Midget Louver's standard line now offers chrome, anodized, copper, and aluminum in 1, 1½, 2, 2½, 3, 4, and 6 inch sizes. All Midget Louvers are recommended by the American Paint and Varnish Association. Write for full information on humidity control—

MIDGET LOUVER COMPANY

6 WALL STREET • NORWALK, CONNECTICUT.

**Ro-WAY Commercial Doors now available
with MASONITE® DORLUX® PANELS**



there's a Ro-Way for every Doorway

**COMMERCIAL
INDUSTRIAL
RESIDENTIAL**

No extra cost • Lifetime guarantee

Ro-Way commercial and industrial doors have always been noted for outstanding quality in design, materials, construction and performance.

Now Ro-Way adds another fine feature—Masonite Dorlux panels. Optionally available on any custom-built commercial model, Dorlux panels offer many advantages:

- A dense, grainless material with a strong, 2-ply finished thickness of 1/4"
- Impact strength equivalent to or in excess of 1/4" plywood
- Effectively resists knocks, bumps and other hazards
- Written guarantee not to split, splinter, crack or delaminate
- Maintains dimensional stability under all weather conditions
- Smooth surface takes and holds paint beautifully to look new longer

One more good reason to specify Ro-Way—for all your commercial and industrial overhead type door applications.

ROWE MANUFACTURING CO., 770 Holton St., Galesburg, Ill.



Nationwide sales and installation service. See your classified telephone directory for nearest Ro-Way distributor.

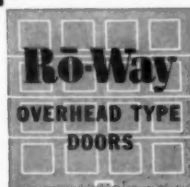

©MASONITE CORPORATION

**EXTERIOR GRADE DORLUX® PANEL
Lifetime Guarantee**

The panels of this door are Exterior Grade Dorlux, a product of Masonite Corporation. Dorlux is a wood product selected by the manufacturer of this door to give you the best in quality, beauty, and service. These panels are guaranteed not to split, splinter, delaminate or crack due to any natural conditions of weathering. If a Dorlux panel fails in any of these ways, notify Masonite Corporation, giving conditions of failure and name of door manufacturer. After verification of the failure, Masonite Corporation will furnish a new door section or an entire new door, depending on the circumstances, at its expense.



ROWE MANUFACTURING CO.
GALESBURG, ILLINOIS



Another Area of Condensation banished forever!

THESE
UNIQUE
ROOFING PANELS
DRY THEMSELVES
BY WEATHER AIR
VENTILATION

In the last large area of condensation — in and under the roofing — vapor barriers have failed to give anything but a partial answer. Wilson Air-cor Roof Decking now gives the final, complete answer with a scientific method of removing moisture from the decking itself — by *weather air ventilation*.

Architects and builders are no longer limited — by local conditions of climate — in their selection of the finished roofing material. For any type of structure and any pitch of roof, Wilson Air-cor provides the dependable roof decking.

126 days of testing by the Engineering Research Department of a leading State University demonstrated "the feasibility of actually drying a wet roof of the Air-cor type by weather air ventilation." The published report recognizes the impracticality of a perfect vapor barrier. With Wilson Air-cor, there is no need for a perfect barrier. The revolutionary principle of ventilation embodied in Wilson Air-cor Roof Decking overcomes the severest conditions of humidity and temperature. Extensive research and actual use prove that Wilson Air-cor makes condensation a problem of the past.

The description of this remarkable product in the Homasote Handbook begins: "The panel consists of 2 x 2 wood members 12" o.c. nailed and glued between two pieces of 1 1/2" Homasote. On the lower inside of the Wilson Air-cor Panel there is 3/4" of batt type insulation, with a vapor barrier on the bottom side, and a ventilated

paper on the top side. At each end there are two small wood blocks to support the Homasote. With only these two small blocks, there is a width of 16" at each end for air to flow from panel to panel." Air enters at the roof edges—where a rake mold is nailed on 3/8" blocks over screen wire—and insect-free air circulates the length of the roofing.

The Handbook continues with specifications, test data, and building instructions. For example, you may be surprised to learn that the problem of ridge and filler has been taken care of with the Wilson Air-cor Ridge Panel. You will be happy to find that Wilson Air-cor is actually a finished ceiling—with three beautiful under-surfaces to choose from (or even Sote Asbestos Board). Accurate tables and complete diagrams give the *right* information, from width of ridge required for any number of courses, even to pre-drilled nail holes — just one more example of the *know-how* of the Homasote Handbook.

The new 68-page Homasote Handbook has the right answers to 99 other building problems—answers backed by 46 years' experience in the making of quality materials. We are proud of this book, and have confidence in its basic value to every architect, builder, and dealer. May we send you a copy? Kindly address Department G-3.

WILSON
AIR-COR
ROOFING
PANELS

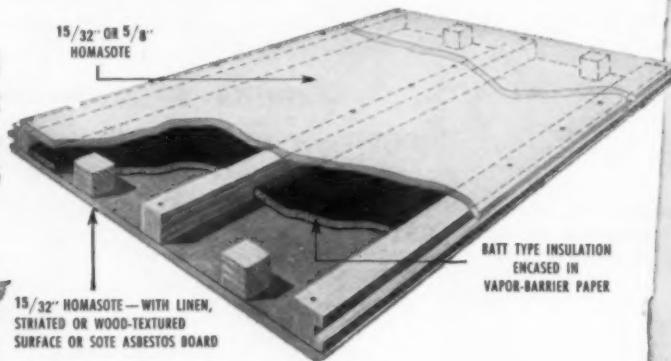

1 1/2" HOMASOTE — WITH LINEN,
STRIATED OR WOOD-TEXTURED
SURFACE OR SOTE ASBESTOS BOARD

BATT TYPE INSULATION
ENCASED IN
VAPOR-BARRIER PAPER

HOMASOTE COMPANY
TRENTON 3, NEW JERSEY



for small-space convenience

add **HALL-MACK®** *Towel Rings*

to your plans...

Hall-Mack's complete line of towel rings combines modern beauty with utility to add the final touch of convenience to any bathroom. Easily, quickly installed—they require but a few inches of wall to provide *extra* towel space wherever needed.

When you specify Hall-Mack bathroom accessories you can be sure of *quality* and years of useful service. There's a wide selection of new and unusual items—a complete line in several price ranges—and the best known name in bathroom accessories. Specify Hall-Mack always!

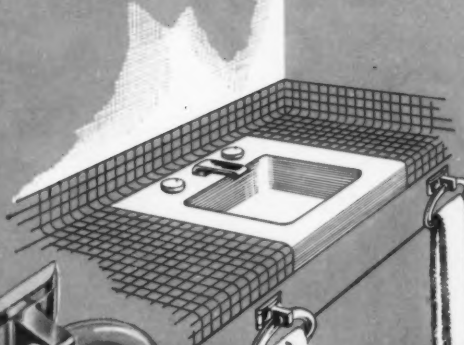

#384 Crystalcrome Towel Ring



#386B Ebony black lucite ring



#386 Crystal clear lucite ring



#386C "Stardust" lucite ring studded with twinkling metallic chips

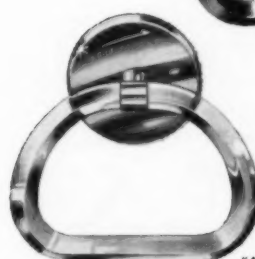

#486 Aristocrome lucite ring

All Hall-Mack Towel Rings are stirrup-shaped for smart appearance and ease of handling...

...Heavy cast bases are finished in gleaming chromium plate.



#686 Coronado chromium plated brass ring



CLIP
this coupon
today
for more
bathroom
ideas!

HALL-MACK COMPANY

1380 West Washington Blvd.
Los Angeles 7, California

Please send me FREE color brochure.

name _____

address _____

city _____ zone _____ state _____

AB-7

What's the secret behind the home that "sells like crazy"?



Better living—today's most important buying motive.

Why is it some new homes move slowly while others with fairly high cash requirements "sell like crazy"? The difference is often "better-living" extras. People today want to live better, and to most people this means to live better electrically.

Housewives and mothers are convinced that a work-saving, time-saving electric kitchen is worth every penny it costs. Where weather is a problem, electric air conditioning becomes a "must," not a luxury, in a better-living home.

They've been reading mouth-watering advertisements for years, selling themselves on electric dishwashers, clothes washers, dryers, indirect lighting, remote control wiring, all the wonderful, comfortable features that only electricity makes possible. They want them *now* in the house they are willing to buy.



National TV Campaign. Every month over 30 million people will see and hear the Live Better Electrically story on the full CBS network. Electric utilities throughout the country will broadcast the same message on local TV and radio.

modern electrical features, the up-to-date wiring in your homes, and they'll "sell like crazy." That's the secret.

Send now for the 72-page full-color book "New Step-by-Step Ideas to Help You Live Better Electrically"—the same book your prospects will be reading. For your copy call or write your local electric utility, or write Live Better Electrically, P. O. Box 505, Great Neck, L. I., New York, enclosing 10 cents to cover the cost of handling.



National Magazine Campaign. Beginning in April, millions of prospects have been reading colorful "spectaculars" in Life, Saturday Evening Post, Look and leading women's service and shelter magazines. Big ads like these sell Live Better Electrically in a dramatic, convincing and memorable manner.

Living better electrically—that's the key to buying appeal. It's a *feature* that smart builders include and promote in the homes they offer. It's a *feature* that prospects look for, and when they find it—they buy!

Offer better living . . . electrically and you'll sell more houses!

A national advertising and publicity campaign will be working for you year in and

year out to promote the theme "Live better . . . electrically." When you identify your homes with this campaign, you're on the way to closing a sale. Build better electrical living into your homes. Tell about the

Billboards. All over the country electric utilities will be displaying this "Live Better Electrically" message where your prospects will see it. They'll see it when they're on the road, looking for that "better-living" home!



Display the LIVE BETTER . . . Electrically symbol at all your homes. You'll appeal to your prospects' desire for better living.



The Unit You Will Use Every Hour of Every Day

There is more flexibility in a tractor with a back-hoe and loader than in any other equipment on the construction site today. You'll use it on more different applications than anything else you own. Trenching for footings, service lines, sewers and drains—digging holes for tanks and catch basins—loading aggregates and levelling and back filling and light stripping—carrying materials and supplies, cleaning up and distributing topsoil—and dozens of other jobs. It's an inexpensive machine you can easily afford to keep on the construction site, full time,

for the many odd jobs that crop up so consistently.

The two big reasons why you see more Sherman Power Diggers than any other kind are simply these: You get more production from a Sherman and your Ford Tractor Dealer, having sold so many, is equipped and skilled in helping to keep your machine on the job working at peak output without costly downtime.

Now is the time to see your Ford Tractor Dealer for a demonstration of this dependable, high production back-hoe; or, write for Bulletin No. 743.

See the Sherman
Power Digger soon
at your local
FORD TRACTOR DEALER



*Designed, Engineered and
Manufactured jointly by
Sherman Products, Inc.,
Royal Oak, Michigan.
Wain-Roy Corporation,
Hubbardston, Mass.

©1956 Sherman Products Inc.

★
AllianceWare

**helps make possible these unusual
 homes at budget prices**

★



**TYPICAL HOMES IN
 PLYMOUTH MEETING
 PARK DEVELOPMENT**

Architect:
 Howard O. Krasnoff
Builders:
 Fox-Bilt Homes, Inc.
Plumbing Contractor:
 National Plumbing &
 Heating Co.
Plumbing Wholesaler:
 H. B. Pancoast Co.



**All Fox-Bilt Homes include these AllianceWare
 fixtures—in color—Champion Bathtub, Two Linda
 Lavatories and Two Closet Combinations**



Two Philadelphia builders—Bob and Dick Fox—have always dreamed of homes—priced within the reach of most families—that would contain many of the luxurious details generally found only in more expensive dwellings.

Today—in Plymouth Meeting Park—suburban Philadelphia—Fox-Bilt Homes, Inc. is erecting the first group of 315 unusual split-level homes containing many of the Fox Brothers' ideas.

Designed to sell at a low \$14,850, these homes incorporate many luxury features . . . among them AllianceWare Champion bathtubs—two AllianceWare Linda lavatories and two closet combinations in each home. All AllianceWare fixtures are in color.

Fox Brothers chose AllianceWare, they tell us, because of AllianceWare's quality construction, decorator styling and wide color selection—sound reasons why they expect AllianceWare bathrooms to be an important sales feature of their unusual homes.

ALLIANCEWARE, INC. • Alliance, Ohio
Bathtubs • Lavatories • Closets • Sinks
 Plants in Alliance, Ohio; Colton, California; Kilgore, Texas

newly designed, lower cost yearound airconditioning systems

help builders close more sales

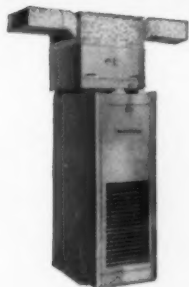

Hi-Boy Heating
with Plenum Type Cooling



Lo-Boy Heating
with Duct Evaporator Cooling



Counterflow Heating and Cooling

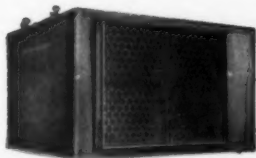

Suspended Horizontal Cooling

Builders can now choose from four compact WILLIAMSON Wethermatic Yearound Airconditioning systems . . . the cooling equipment requires *no floor space*. Williamson Wethermatics are low cost, quickly installed and premerchandised with an all-round national consumer promotion in major shelter magazines.

WILLIAMSON

"WETHERMATIC" SYSTEMS CONSIST OF: The "SPECIAL" Line—A Builders Type Warm Air Furnace

New lower prices reflecting mass production savings

- 20 gas-fired, 12 oil-fired models
- 60,000 to 145,000 B.T.U. Range
- Hi-Boy, Lo-Boy, Counterflow, Gravity and Horizontal Units
- Pre-Wired, pre-Assembled, factory test-fired.

New color choice . . . Gray Metalescent or Gleaming White

AIRrefrigeration Waterless Cooling—

- No floor space installations
- No costly sewer or water connections
- Internally factory wired, easily installed.
- 2, 3, 4, 5 or 7½ ton size models
- Console and suspended models where desired.

Prefabricated Duct Pipe & Fittings—For Heating and Cooling

- Die Cut, prefabricated, each fitting interchangeable with others
- Fittings shipped packed per house plan
- Tailor-made look, designed to fit within the joists
- Designed for minimum air resistance—maximum air flow efficiency.

See our 12-page
catalog insert
in SWEET'S
1956 Light
Construction Files.

THE WILLIAMSON COMPANY
3330-A5 Madison Rd., Cincinnati 9, Ohio

Please send me information on:

- Yearound Airconditioning Cooling Equipment
 Heating Equipment Duct, Pipe and Fittings

Name _____

Firm _____

Address _____

City _____ Zone _____ State _____

WINFIELD

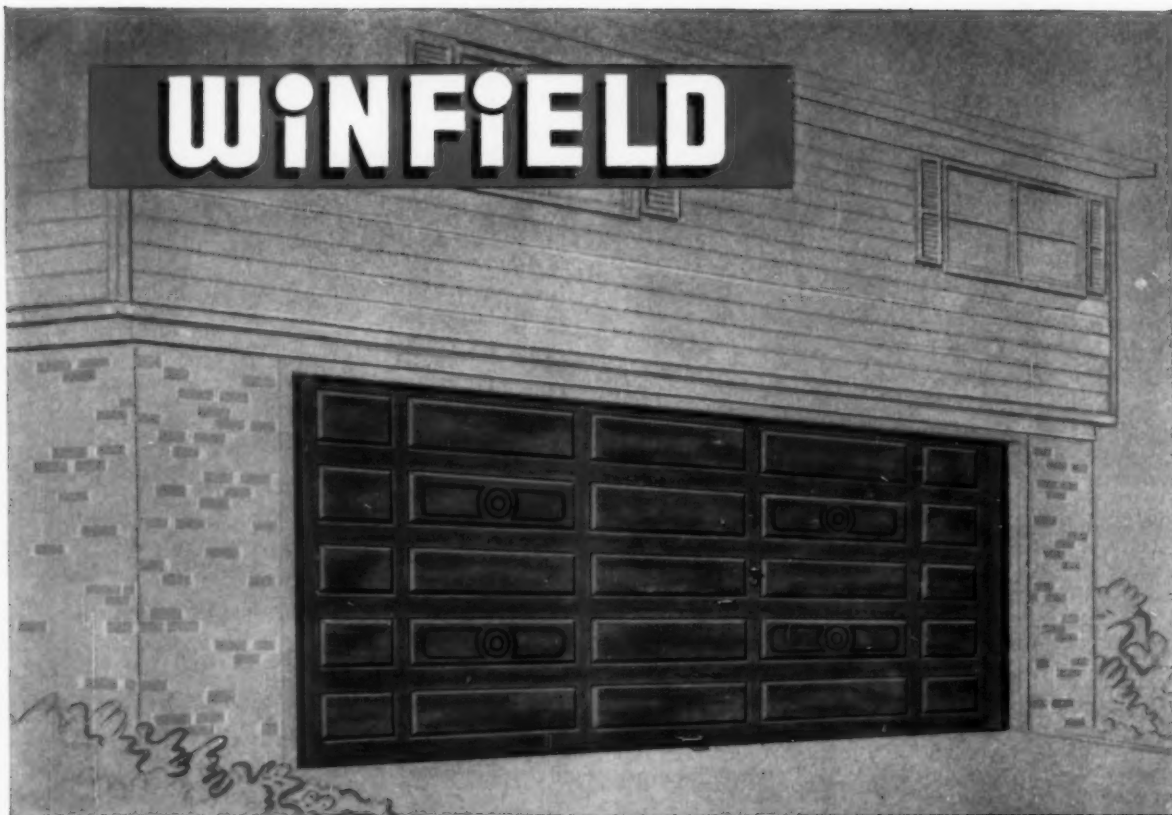

FIRST WITH THE BEST
California Redwood
SECTIONAL GARAGE DOORS

WINFIELD was the *first* company to produce sectional garage doors made of finest California Redwood . . . the only door that will add the mark of distinction to your finest home! Smooth and easy in operation, Winfield's California Redwood doors are designed to last as long as the building.

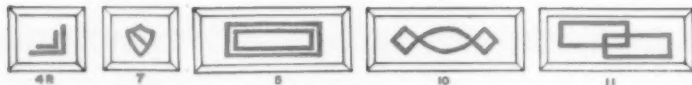

Here is distinctive garage door beauty! These attractive designs are a few of the raised panel carved motifs WINFIELD offers — arranged to specification.

WINFIELD

Door Corporation

MUNCY AVENUE — WEST BABYLON, N. Y. — P.O. LINDENHURST, N. Y.

for **BEAUTY** — California Redwood is singularly attractive . . . blends with any architectural design!

for **DURABILITY** — California Redwood won't warp or cup through years of service . . . resists decay, termites.

for **LOW-COST MAINTENANCE** — California Redwood holds finishes and paint longer, even under extreme weather conditions!

Send for **FREE** illustrated brochures on WINFIELD'S complete line of outstanding industrial, commercial and residential garage door values!



Here is the Industry's Most Complete Line of Oil Heating Boilers and Units

A fully integrated line of Oil Heating Boilers and Units, in both cast iron and steel, is now available under the famous and dependable National-U.S. brand name . . . boilers and units especially designed and engineered for modern oil heating at its finest . . . to meet all heating requirements from small homes to large commercial and industrial buildings.

Specialized Boilers Exclusively for Oil Firing

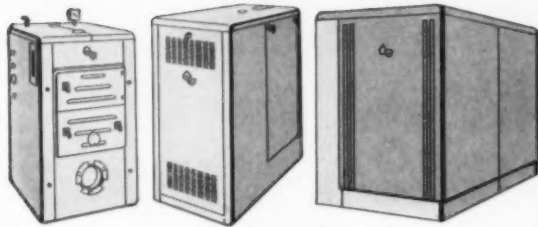

"46" Series Oil Heating Boiler (Wet leg type).

"20" Series Oil Heating Boiler (Wet base type).

"25" Series Oil Heating Boiler (Wet base type).

Cast Iron Boilers for Automatic Firing and Oil Heating Units

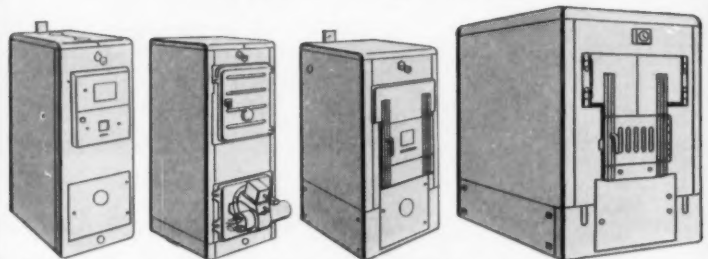

"10" Series Boilers

"12" Series Boilers

"27" Series Boilers

"37" Series Boilers

Steel Boilers and Oil Heating Units

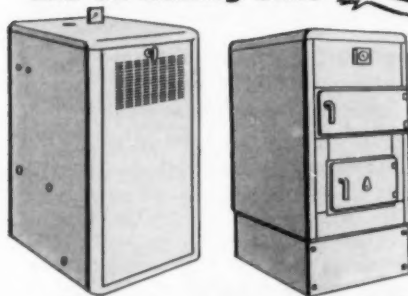

"17" and "24" Series Residential Steel Oil Heating Units

"26", "29" and "39" Series Residential Steel Oil Heating Units

NATIONAL-U. S. PACKETS . . . automatic, all-in-one home heating units (oil-fired)

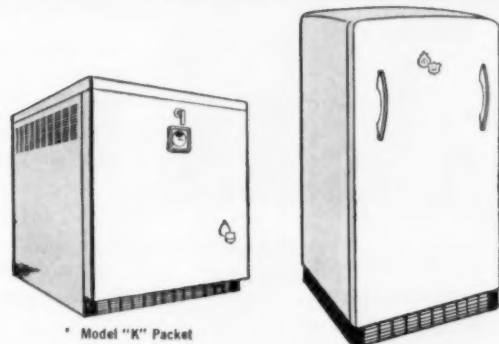

Model "K" Packet

Model "U" Packet

All types of modern, National-U.S. Heat Distributors work effectively with oil-fired boilers—Baseboard and Convectors (both cast iron and non ferrous); Cast iron tubular and wall radiators and Fintube radiation.

All sizes of residential and commercial conversion oil burners are also available.



National-U.S. Radiator CORPORATION

HEATING AND AIR CONDITIONING DIVISION
Johnstown, Pennsylvania
Sales Offices and Representatives in principal cities

Write for bulletins giving full information and engineering data with ratings on each individual series of National-U.S. Oil Fired Boilers or Units.



All National-U.S. Oil Heating Units are rated by laboratory tests in accordance with the Rating Code of The Steel Boiler Institute and The Institute of Boiler and Radiator Manufacturers, and conform with the ASME Boiler Construction Code of The American Society of Mechanical Engineers.



VITRIFIED CLAY PIPE

first choice for Another **BIG** Housing Project!

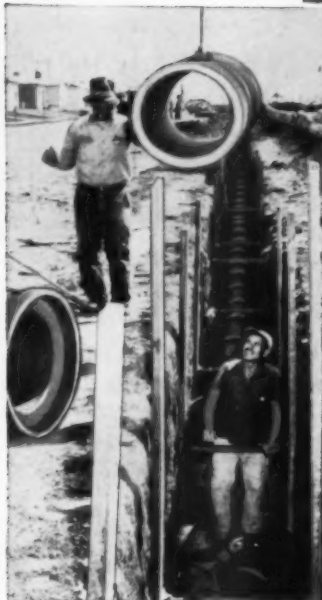

TORRANCE, CALIFORNIA is attracting new families by the thousands with an unusual combination of job opportunities, ideal climate, and beautiful beaches. To meet the tremendous demand for modern housing, the vast Southwood Homes project is well underway, with a total of 2200 new homes planned and 816, comprising the first unit, already under construction. More than 67,000 feet of 4 through 18-inch Vitrified Clay Pipe have been installed as house connections, feeders, and mains.

Like many other mass-construction builders, those in charge of Southwood Homes know that it pays to use the best in sewerage materials. It pays in faster, more economical construction, as well as in dependable, trouble-free service—since Clay Pipe is the only sewerage material that is guaranteed . . . and *never wears out*.

Owner, subdivider, and contractor: Milton Kauffman—
Don Wilson Co.

Sewer system designer: The Engineering Service Corp.

Sewer contractor: N. A. Artukovich Construction Co.

Vitrified

CLAY



PIPE

G-1056-1



NATIONAL CLAY PIPE MANUFACTURERS, INC.

1820 N. Street, N.W., Washington 6, D. C.

206 Connally Bldg., Atlanta 3, Ga.

100 N. LaSalle St., Rm. 2100, Chicago 2, Ill.

703 Ninth & Hill Bldg., Los Angeles 15, Calif.

311 High Long Bldg., 5 E. Long St., Columbus 15, Ohio

Progress in Public Health - Through Clay Pipe Research

Revolutionary Rheemaire

...a new kind of home air-conditioning system that cuts operating costs almost in half!



Here's the biggest news for builders and buyers ever! The *Rheemaire*—from Rheem—an entirely new kind of cooling for the homes you build. *Complete* home cooling you can install faster than ever before—and *sell* faster to *all* your buyers. For every objection to existing units is designed *out* of the amazing new Rheemaire.

It takes up no usable space indoors, eliminates the noise problem, and needs no costly recirculating system or cooling tower. It ties right into the existing ductwork of the homes you build with forced air heat, and adapts to others. One- or two-story homes, with or without basements.

Rheem did it all with a new Air-Film Condenser that *nearly doubles* compressor capacity, and new pre-charged

refrigerant lines with quick-connect fittings. No flare connections—no system evacuation or charging—and no need for refrigeration mechanics.

Hard to believe? Rheemaire was thoroughly tested in homes of all types and sizes in the hottest parts of the country—through one of the hottest summers in history.

YOU CAN RELY ON  MANUFACTURING COMPANY

Seattle • Houston • Chicago • South Gate, California • Sparrows Point, Maryland

**FREE
BOOKLET**

Write to Rheem on your company letterhead for an illustrated booklet and full information about the amazing new Rheemaire. Rheem Manufacturing Company, 7600 S. Kedzie, Chicago 29, Illinois, Dept. AB-5

\$1000 CAPACITY GUARANTEE

Here's complete protection and positive proof, that the new Rheemaire is thoroughly dependable. So carefully has it been tested and proved, that Rheem has guaranteed the Rheemaire to operate at its rated capacity. It's the only guarantee of its kind that you can offer your home buyers!

Homes *SELL FASTER* with

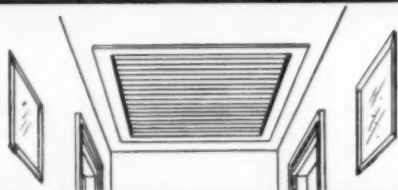
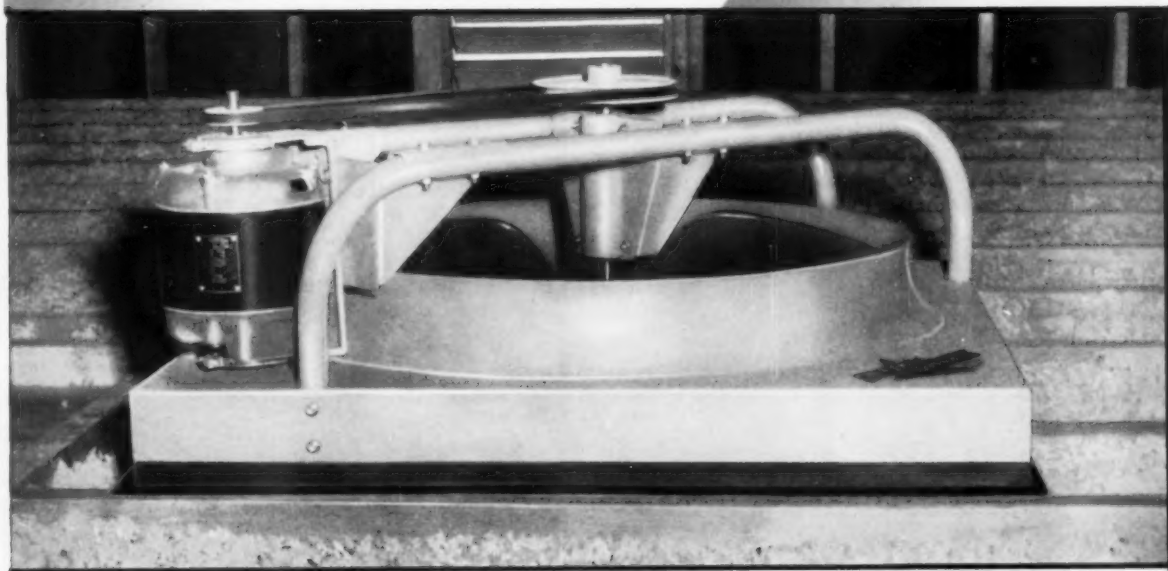

(A) ACTIVE AIR throughout the house; restful sleep on hottest nights—a strong selling “plus” for homes with these new 24-inch and 30-inch ACTIVE AIR attic fans. Ball bearings, lifetime lubrication in motor and fan shaft. Designed for quick, low-cost installation, even in narrow hallways and low-headroom attics.

To put more ACTIVE SALES power behind the homes you build, sell the advantages of modern living with “ACTIVE AIR.” Emerson Electric fans provide a comfortable “atmosphere” throughout the home, and are recognized everywhere as the leaders in value. Use the Emerson-Electric 65-year reputation for guaranteed quality fans to influence prospects and close sales. Send for Emerson-Electric Fan Bulletin No. 1028. THE EMERSON ELECTRIC MFG. Co., St. Louis 21, Missouri.

A New 24-inch and 30-inch ACTIVE AIR attic fans. The 24-inch fan, 5200 C.F.M., list price is only \$76.55, ceiling shutter list \$27.85; list price of 30-inch fan, 7000 C.F.M., is \$85.30, ceiling shutter list \$31.00.



B For kitchens and bathrooms, the 8-inch ventilator for wall or ceiling installation lists at \$23.75.



C The 36-inch ceiling fan circulates 3800 cubic feet of air per minute; the 52-inch, 7000 C.F.M. List price only \$74.10 for 36-inch downdraft model.



"Active Air" fans

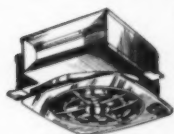

(B) Get rid of smoke, odors, steam and heat with this new, popular-priced 8-inch Emerson-Electric ACTIVE AIR ventilator. Its mirror-finish grille strikes a popular note with home buyers. For kitchens, bathrooms, rathskellers and utility rooms.

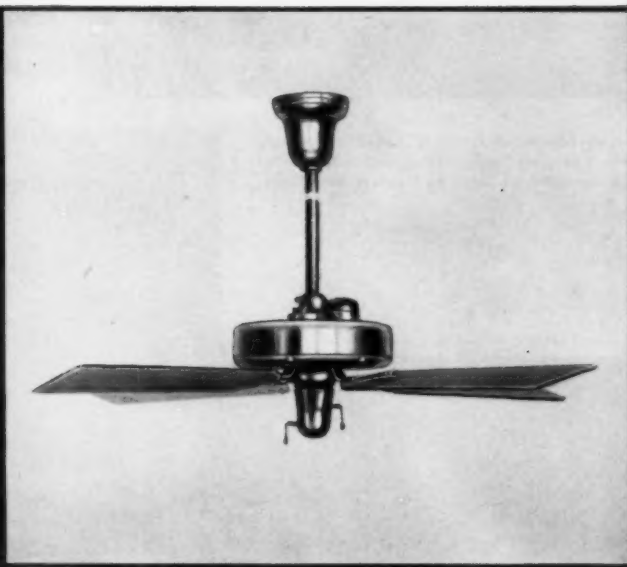

(C) More breezes in breezeways, porches or sunrooms. The "ever-reliable" Emerson-Electric 36-inch and 52-inch ACTIVE AIR ceiling fans have a real comfort appeal to home buyers. Downdraft and electrically reversible models.



*All backed by the famous 5-year
factory-to-user guarantee!*

Emerson-Electric
of St. Louis • Since 1890





The office-lobby at Travelers' Lodge is strikingly modern in every respect. Streamline copper tubes have been cleverly used as fireplace hearth supports.



This handsome heating and with



Year-around comfort is the keynote here and Streamline copper tube and fittings help maintain it.



The Travelers' Lodge, a strikingly modern motel just opened at Marysville, Michigan, lavishes every convenience on its guests. Each room has wall-to-wall carpeting, television, radio, room telephone with switchboard service, tiled bath with both tub and glass enclosed shower . . . and individual room heating and air-conditioning control. To make sure that this dial-your-own-temperature heating and air-conditioning system will be dependable at all times, Mueller Brass Co. Streamline copper tube and solder type fittings have been installed throughout. The entire water supply system, too, from the street to the shower heads, is a Streamline installation . . . those modern baths will always have water at the right temperature and volume due to these smooth-flowing, corrosion-free copper and brass lines. Even the sprawling underground lawn sprinkler system employs Streamline copper tube and fittings for the mains combined with hundreds of feet of Streamline polyethylene plastic pipe for the branch lines. In all of these installations, the non-clogging properties and freedom from corrosion or leakage of Streamline products add up to a lifetime of dependable service without maintenance for the Travelers' Lodge.

The next time you are specifying or installing materials for the heating, air-conditioning, or water supply and drainage system of a building—small or large, single or multiple units—make sure it's Streamline copper tube and solder type fittings . . . you can't do better. Write today for complete information.

There'll never be any trouble with this underground lawn sprinkler installation because it's Streamline all the way. Mueller Brass Co. valves, tube and fittings can be seen at the bottom of the picture with the long, easy-to-lay runs of Streamline plastic pipe stretching up toward the motel at the top. Note the ease with which the Streamline plastic pipe has been snaked around a large boulder (near the top of picture) encountered during the trenching.



new motel is assured trouble-free plumbing,
air conditioning for years to come
Streamline® copper tube and fittings

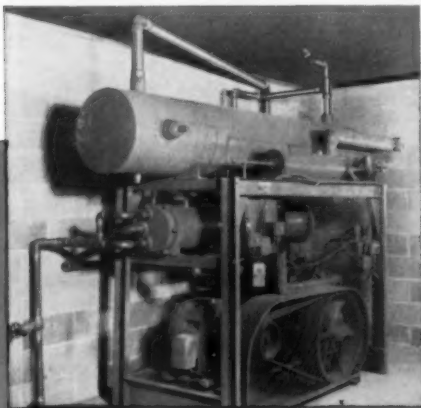

The photograph of the service room below illustrates the extensive use of Mueller Brass Co. Streamline copper tube and solder type fittings, for both the heating plant and hot water supply. All connections and leads on the refrigeration unit, which is housed in a separate room (left), are also Streamline. In all, there are over 2,000 feet of copper tubing in the building and all lines are carried in a special underground "plumbing tunnel".

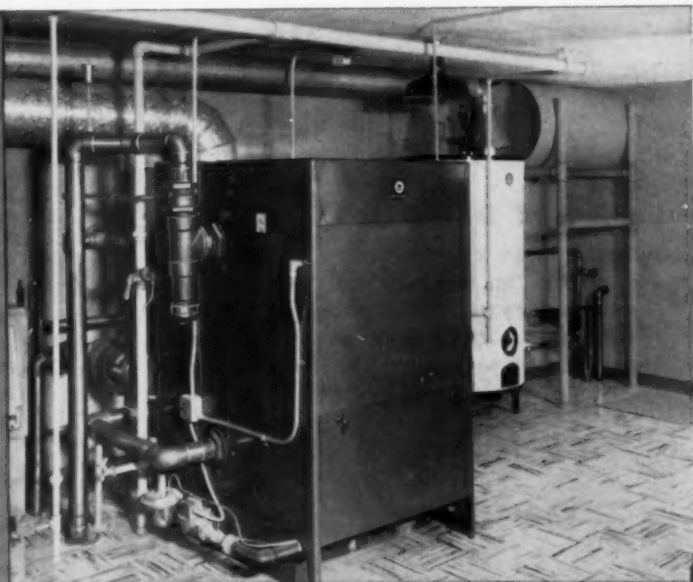

MUELLER BRASS CO. PORT HURON 84, MICHIGAN

Now! "Built-Ins" You Can Install
Even on **LOW COST JOBS!**



Admiral. BUILT-IN ELECTRIC RANGES

FLEXIBLE DESIGN, TOP QUALITY AT DOWN-TO-EARTH PRICES!

Admiral values cut your costs, enable you to offer MORE on virtually every job. And you give them every wanted feature including "ATC" cooking unit to make every pot and pan automatic, King-Size Rotary Roaster, Automatic

Timer Clock, Admiral Flex-O-Heat Controls. Oven doors in brushed chrome or yellow, pink, green and coppertone porcelain. Surface units in stainless steel or porcelain colors to match oven doors. Get the full Admiral story now!



Refrigerator Buy! COLORS! FEATURES!

Crisp, straight-line styling. Choice of decorator colors (extra). Full-width freezer chest and drawer. Amazing low price. The coupon brings full details.

MAIL COUPON FOR DETAILS!

Admiral Corporation • 3800 W. Cortland St. • Chicago 47, Ill.
Please send me complete information on Admiral Built-Ins
 Refrigerators Freezers Electric Ranges
 Air Conditioners and Dehumidifiers

Name _____ Title _____

Firm Name _____

Address _____

City _____ Zone _____ State _____

No. of Units Planned _____

**Record Breaker
in the low-cost field**

Over 1,000,000
installations
in a matter of
months!

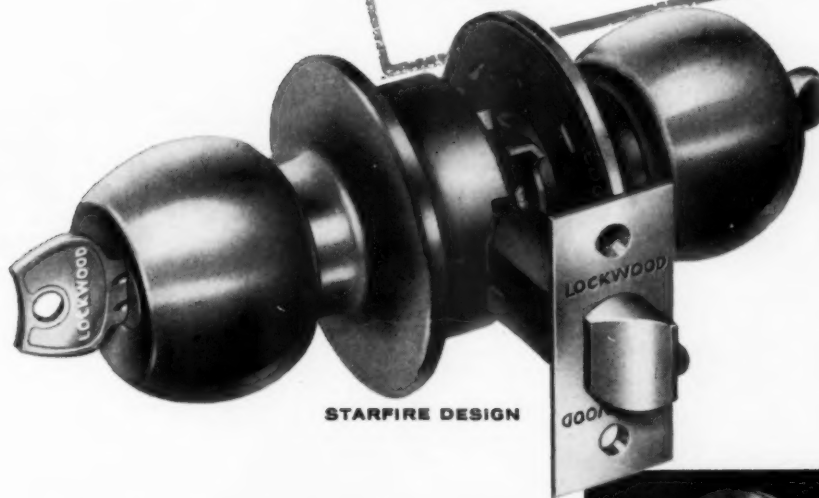

STARFIRE DESIGN

FIRST . . . Quietly introduced just before the turn of the year . . . for test purposes.

THEN . . . A history making demand from all who saw it.

NOW . . . Available for prompt shipment in all standard finishes . . . and with 5" backsets and decorative trim plates.

LOCKWOOD HARDWARE MFG. COMPANY
Fitchburg, Massachusetts



THUNDERBIRD DESIGN

New LOCKWOOD "R" SERIES

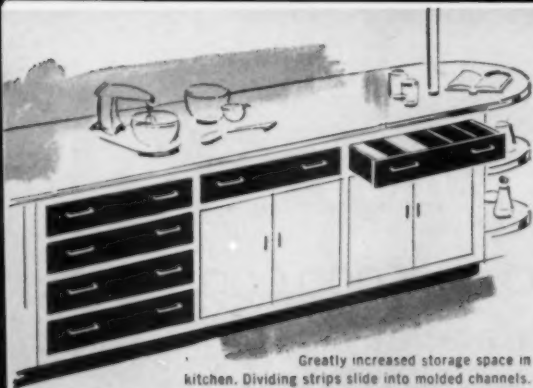

Greatly increased storage space in kitchen. Dividing strips slide into molded channels.

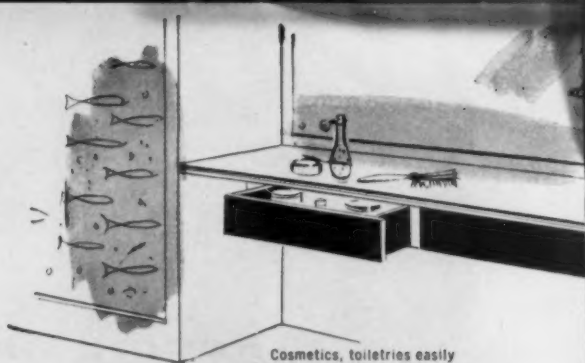

Cosmetics, toiletries easily stored in bathroom drawers. Humidity won't warp drawers—easy to clean.



Night tables made with plastic drawers have modern appearance, slide easily.

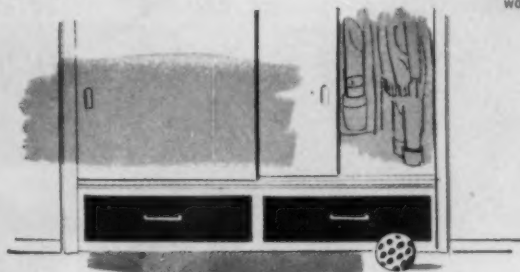

Drawers in children's bedroom provide convenient storage for toys.

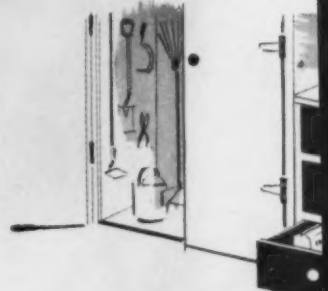

Drawers in garden tool crib to store seeds and small tools are unaffected by moisture and weather.

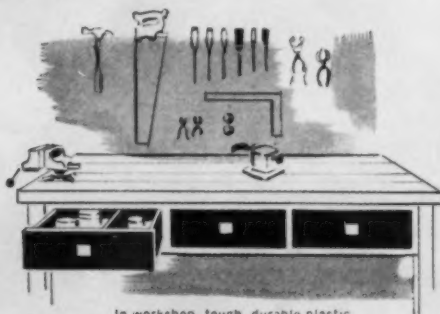

In workshop, tough, durable plastic drawers provide for tool and material storage.

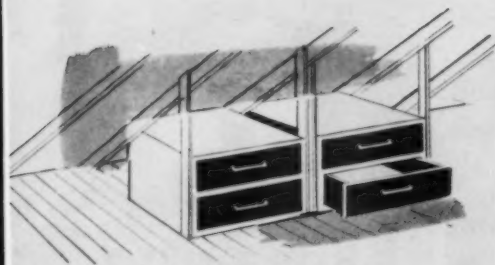
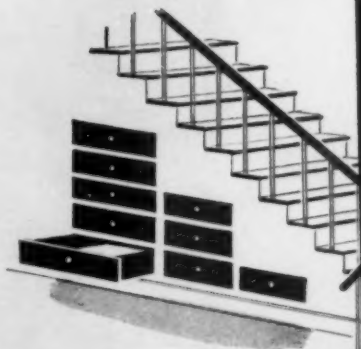

Stack of drawers in attic for storing out-of-season clothes. Easy to clean, rodent resistant.

Drawers in garage for storing auto parts and tools. Unaffected by oil and grease, clean with wipe of a cloth.

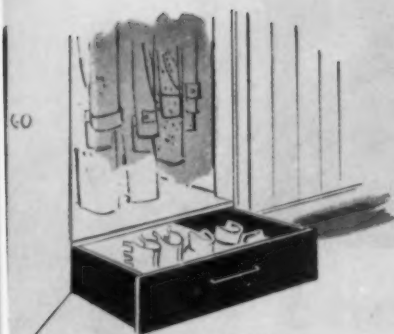
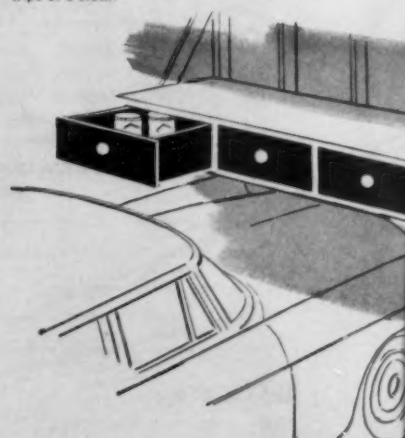

Drawer in bottom of entry closet stores wet overshoes—not affected by moisture.



Storage drawers under built-in sofa-bed stores bed clothes—linens.

Get a bigger share of remodeling work...

11 new ideas for remodeling with plastic drawers

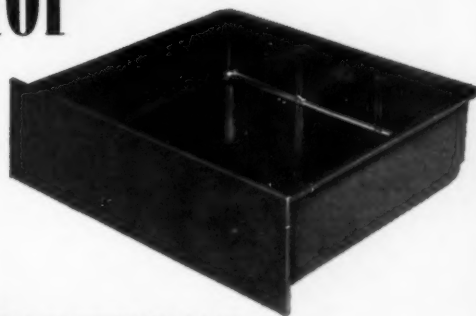

Almost every remodeling job today specifies additional storage space ... and now you can provide the best kind ... with ready-to-use drawers molded of **BAKELITE** Brand Phenolic Plastic. And at a cost comparable to conventional drawers of quality construction.

These tough, warp-free drawers offer unusual storage unit possibilities in every room. Home owners are quick to see the advantages of the smooth easy-to-clean surfaces, rounded corners that won't trap dust. The glossy-black finish that harmonizes with every decorative plan ... never needs refinishing.

You will find them easy to install. Uniform sizes eliminate time-consuming fitting, just drill holes for the hardware and slide into place. Center guide and runners are already molded in.

Today, see your building supply dealer about these molded drawers. Or, send the coupon for further information and names of manufacturers.

Under stair storage drawers utilize waste space.



BAKELITE COMPANY

A Division of Union Carbide and Carbon Corporation UCC 30 East 42nd Street, New York 17, N. Y.

The term **BAKELITE** and the Trefoil Symbol are registered trade-marks of UCC

BAKELITE COMPANY Dept. QB-5
A Division of Union Carbide and Carbon Corporation
30 East 42nd Street, New York 17, N. Y.

Please send me information on variety of sizes of drawers molded of **BAKELITE** Brand Phenolic Plastics and names of manufacturers who can supply them.

NAME _____ TITLE _____
COMPANY _____
ADDRESS _____
CITY _____ ZONE _____ STATE _____

HOME AIR CONDITIONING INSTALLATION PROBLEMS SOLVED!

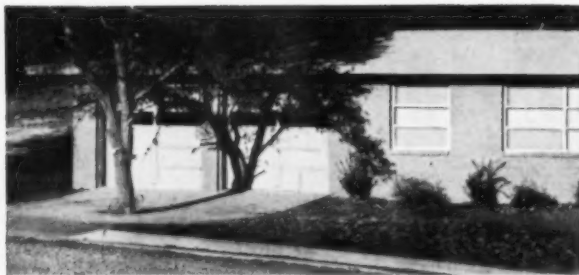

Typhoon
Air Conditioner-Furnace
in standard-size closet
2-3-5-8 Ton Sizes

TYPHOON WEATHER- SELECTOR

specified for world's

largest residential air conditioning project

Designed in close consultation with leading builders, the Weather-Selector provides perfect climate control, summer and winter. Economical in application for all price level homes—specified exclusively for the Barton Hills Development, Austin, Texas—1,152 year-round air conditioned homes, world's largest residential air conditioning project.

Solves every major problem that stands between builders and extra profits:

NO SPACE PROBLEM Amazingly compact, only 70" high, tucks into standard-size closet.

NO WATER PROBLEM Completely air cooled, *waterless* in operation.

NO ALTERATION PROBLEM Typhoon Cost-Saver Plan is a detailed blueprint for standard closet installation—no guesswork, no remodeling.

NO FINANCING PROBLEM Ready acceptance by bankers and appraisers facilitates mortgage financing. Easy FHA-VA approval.

NO SELLING PROBLEM Comprehensive Builder's Kit of "Connie Cool" sales promotion aids makes it easy to sell every prospect.

For complete information, call your nearest Typhoon dealer or write Typhoon for name of dealer in your area.



TYPHOON

AIR CONDITIONING COMPANY

DIVISION OF HUPP CORPORATION • 505 CARROLL STREET, BROOKLYN 15, NEW YORK



Lake Harriet Methodist Church, Minneapolis, Minn.: Architect, Loren B. Abbett, A.I.A.; Contractor, Kraus-Anderson, Inc.; both of Minneapolis, Minn.

Build better masonry . . .

Why is Atlas Mortar Cement the first choice of more builders than ever before?

Because It Simplifies Mixing—Atlas Mortar Cement reduces the number of materials you store and handle . . . makes it easier to mix and maintain uniform mortar batches.

Because It Holds Its Workability—Atlas Mortar Cement mixes are buttery-smooth . . . retain both their mixing water and workability longer. They keep costs down by making the most economical use of your masons' time.

Because It Is Uniform—Atlas Mortar Cement quality is carefully controlled. Every bag is manufactured to give the same dependable performance.

Mortar made with Atlas Mortar Cement has excellent workability and water retention . . . promotes careful masonry craftsmanship . . . encourages efficient masonry work. Help make your jobs go faster, look better, last longer, when you use Atlas Mortar Cement. Complies with all ASTM and Federal Specifications for masonry cement, which now include requirements for soundness (low expansion) in autoclave.

UNIVERSAL ATLAS CEMENT COMPANY

UNITED STATES STEEL  CORPORATION SUBSIDIARY
100 PARK AVENUE, NEW YORK 17, N. Y.

*Albany • Birmingham • Boston • Chicago • Dayton • Kansas City • Milwaukee
Minneapolis • New York • Philadelphia • Pittsburgh • St. Louis • Waco*

M-55-R

Atlas[®] Mortar Cement

FOR BETTER MORTAR • FOR BETTER MASONRY

UNITED STATES STEEL HOUR—Televised alternate Wednesdays—
See your newspaper for time and station.



MARLITE WALLS AND CEILINGS

beautiful way to lower "in place" costs

Cost goes down, customer satisfaction goes up with Marlite Plank and Block. This new prefinished paneling cuts installation time from days to hours . . . means quality job completions, *when promised*. The secret? Marlite's exclusive tongue and groove joint. It simplifies installation, speeds fitting, conceals all fastening.

This easy-to-handle paneling will please your customers, too. The baked melamine plastic finish is soil-proof. Highly resistant to smudges, stains, moisture—it never needs painting, requires only an occasional damp cloth wiping.

From attic to basement, Marlite is "at home" in every room. It's readily available in beautiful "Companion Colors" styled by Raymond Loewy Associates, plus distinctive wood and marble patterns—all in semi-lustre finish. See your building materials dealer, refer to Sweet's File, or write Marlite Division of Masonite Corporation, Dept. 603, Dover, Ohio.

that's the beauty of **Marlite®**

plastic-finished wall and ceiling paneling



MARLITE DIVISION OF MASONITE® CORPORATION



USF Modular Steel Doors and Frames

help you build to practical standards
and benefit from precision quality



You can benefit by building with USF *standardized* modular Flush Panel Steel Doors and matching frames. They fit! —Yes, they fit each other and fit with all other modular building materials.

Made better!—Manufactured on jigs and fixtures, they give you positive, known quality, in one or a thousand doors, and accuracy of dimensions, square and plumb not possible in 'specials'.

USF is geared to produce precision quality in standardized, modular 1 $\frac{3}{8}$ " Wooster Doors or 1 $\frac{3}{4}$ " Commercial Doors and frames. Make these your standards—help yourself and your client.

United Steel Fabricators,

Incorporated

WOOSTER, OHIO

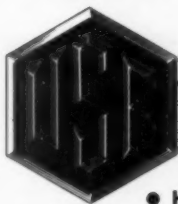

- Steel Doors and Frames
- Prefabricated Steel Buildings
- Steel Bridge Flooring
- Highway Guard Rail
- Corrugated Metal Drainage Products



\$1,000,000 WORTH OF TOOLS, JIGS, FIXTURES GUARANTEE PRECISION

USF has developed approximately \$1,000,000 worth of special tools, jigs and fixtures to guarantee the precision manufacture of *standardized* modular steel doors and frames that meet and exceed industry standards for quality and accuracy.

Perfect design, proved manufacturing methods and years of field service records are assurances of the quality and easy installation USF Steel Doors and Frames lend to every project.

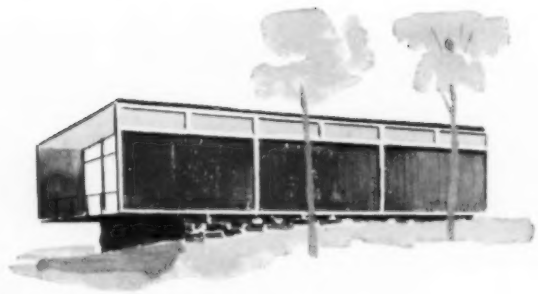
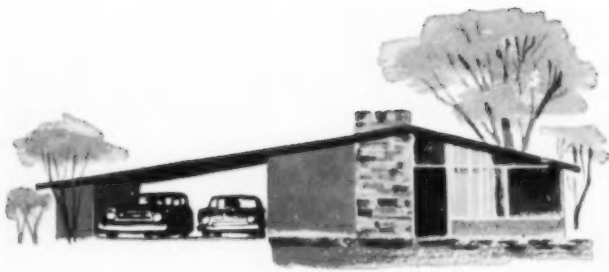

modern construction



calls for



modern sewer pipe

BERMICO®

Streamlined modern construction methods call for the most efficient and most easily installed products. That's why building material wholesalers and dealers recommend—why more architects are specifying—Bermico Sewer Pipe.

And it's why more and more builders and contractors are using this lightweight bituminized fibre pipe—root-proof and corrosion-proof—for house-to-sewer or septic-tank connections.

Bermico Sewer Pipe and Bermiseptic® Perforated Pipe for septic-tank disposal beds are produced in 8-foot lengths, from 2" to 6" in diameter. And *only Bermico* has a complete line of fittings made of the same material as the pipe! Send today for information about this modern pipe.

Brown Company, Dept. HB-7, 150 Causeway St., Boston 14, Mass.

Qualitybilt wood casements with exclusive "Narrow Mullions"

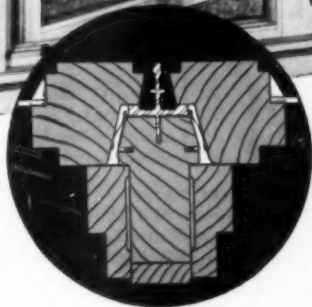

Narrow mullions are reinforced with heavy, cross-shaped aluminum extrusion for greater strength . . . improved appearance.

At last . . . here's a quality wood casement designed for slenderized beauty . . . expertly engineered and precision machined for easy assembly and installation!

It's competitively priced, too . . . bringing it in line for moderately priced homes!

All Qualitybilt wood parts are toxic treated for durability. Sash can be had with divided lights or one light, including 1/2" insulating glass. Standard sizes include two widths — 16" and 20 1/2" glass — and five heights, complete with hardware, screens, and double glazing. Picture windows can also be supplied to combine with the sash.

Stocks are rapidly being established in leading building centers. Contact your dealer, or write us for name of nearest distributor!

arrangements unlimited with Qualitybilt Wood Casements

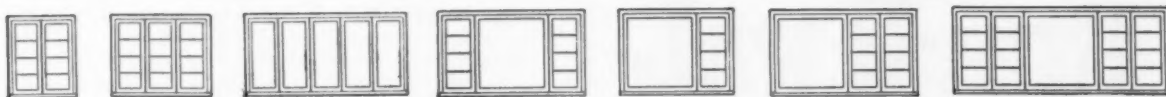

Send coupon for complete details and illustrated catalog.

FARLEY & LOETSCHER MFG. CO. DUBUQUE, IOWA

Since 1875, a complete line of quality building products.

CABINETS — Kitchen, Multiple Use Wardrobe Storage and Vanities
• DOORS — Exterior, Interior, Combination, Garage and Screen
WINDOW UNITS — Awning, Basement, Casement, Double-Hung Storm and Screen • DECORATIVE LAMINATED PLASTICS.

QUALITYBILT Products are sold through wholesale distributors and local building material dealers. Ask for them by name.

FARLEY & LOETSCHER MFG. CO., DUBUQUE, IOWA

Gentlemen: Send along a copy of your 12-page catalog on Qualitybilt Wood Casements.

NAME

ADDRESS

CITY ZONE STATE

CONTRACTOR ARCHITECT DEALER

AB 7-56



DUR-O-WAL[®]

SAFEGUARDS

Masonry Beauty



The Backbone of Steel for Every Masonry Wall

● To preserve original beauty and strength in every masonry wall you build, use only Genuine Dur-O-wal. Dur-O-wal puts more steel per linear foot into the wall and combats cracking in all type of masonry construction. Order only Genuine, Patented Dur-O-wal for every masonry job. Accept no substitutes.



Nationwide acceptance through proved performance means customer satisfaction for you

6 REASONS why Builders Prefer Dur-O-wal

Dur-O-wal:

- assures customer satisfaction
- is easy to handle
- is stocked by most dealers
- trussed design makes all steel work as a unit
- is available for all types of masonry walls
- is economical

Ships in 10 foot Bundles...
EASY TO HANDLE and STORE

Trussed Design
Butt Weld • Deformed Rods

DUR-O-WAL[®]

Write now for complete information, specifications and prices to the Dur-O-wal plant nearest you, Dept. 6F.

Dur-O-wal Div., Cedar Rapids Block Co., CEDAR RAPIDS, IA. Dur-O-wal Prod., Inc., Box 628, SYRACUSE, N.Y. Dur-O-wal of Ill., 119 N. River St., AURORA, ILL.
Dur-O-wal Prod. of Ala., Inc., Box 5446, BIRMINGHAM, ALA. Dur-O-wal Prod., Inc., 4500 E. Lombard St., BALTIMORE, MD. Dur-O-wal Div., Frontier Mfg. Co., Box 49, PHOENIX, ARIZ. Dur-O-wal, Inc., 165 Utah St., TOLEDO, OHIO

Avoid Home Sales-Slump!

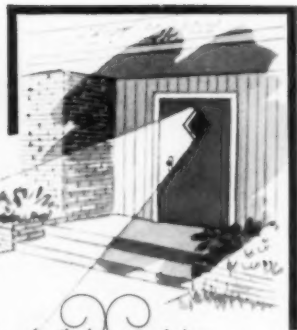

for flush panel doors
VISADOR
door lights and louvers

offer
Quick Sales Appeal

Builders looking for fresh ideas to pep up home sales can well look to doors with Visador lights and louvers. They are attractive — precision-built — and add comparatively little to door costs.

HERE'S THE SCORE WITH VISADOR

Let VISADOR LIGHTS AND LOUVERS start selling homes for you today.

Write for our V-7B Catalog to see the variety of Visador designs available.

1. Doors with hundreds of Visador light and louver designs available through leading building supply dealers.

2. Visador is known in the trade as a leader for quality, service and styling. That's why it's wise to ask for doors with VISADOR.

3. Sold only through building supply jobbers and door manufacturers. If your current supplier does not have doors enhanced with VISADOR, write to us for a list of suppliers in your area.

A few of these designs are shown here

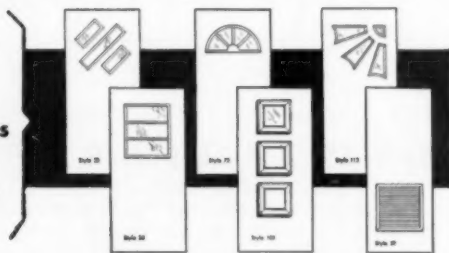

The **VISADOR Co.**

P. O. Box 10312 • Dallas, Texas

PARTNERS WANTED!

by World's Leading Producer of Concrete Forms

Yes, we mean partners. Under our unique licensing agreement, we work hand in hand with our customers, providing the kind of teamwork which means more profits to you. Our concept of teamwork means that our Training Representatives will instruct your crews thoroughly in the use of ROCFORM SYSTEMS so that you can begin operating efficiently immediately. It means that our representatives will call on you month in and month out, helping you to solve any problems that might arise, and continually improving your operation.

Look around you. In all probability, there is a set of ROCFORMS now operating in your neighborhood. Notice the speed with which ROCFORMS are "stripped" from one job and set up on the next, whether it be on the next lot or 20 miles away. ROCFORM's engineered panels are so easily handled that stripping, moving and setting up can be accomplished in only a few hours, enabling the contractor to pour a job every day with each set of forms.

Inquire. Ask your nearby ROCFORM contractors for their opinion. Our customers are the biggest boosters for the famous ROCFORM SYSTEM. They will confirm the fact that this is the fastest method of concrete forming, and, best of all, will demonstrate to you the unsurpassed quality of work it produces . . . straight . . . smooth . . . clean walls, job after job after job. With reasonable panel care (no crowbars . . . only a carpenter's hammer to strip the forms) a set of ROCFORMS will still produce top-quality work after as many as 300 jobs.

Lowest depreciation. This means an extremely low depreciation per job, only about half as much depreciation as other methods of concrete forming, far overcoming the slightly higher initial cost. And, even after the panels are worn out, you still retain 50% of your original investment. *All walers, tie rods, tie rod pins and clamps are guaranteed and will be replaced without charge.*

Financing arranged. Our teamwork concept goes even one step further. If you need financing, you can purchase ROCFORMS for a small down payment and pay off the rest in small monthly installments. The better and additional jobs you pour with the faster, better, cheaper ROCFORM SYSTEM will more than meet the monthly payments.

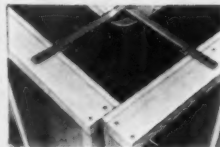

Round corner form eliminates filler strips and results in strong, attractive, rounded basement corners.

Patented wall aligners automatically give wall of uniform desired thickness and line up tops of panels.

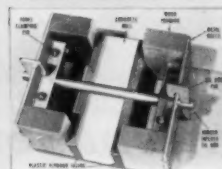

Tapered steel tie rods with special pins hold forms rigidly in place. Can be re-used continuously.

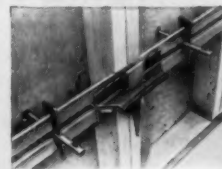

ROCFORM metal walers are permanently built into forms. Sections lock together with patented clamps.

Adjustable outside corner clamps allow for a 3-inch variable without necessity of corner fillers.



Rocform CORPORATION

15160
W. 8 MILE
ROAD
DETROIT 35
MICHIGAN

Get all the facts about this exciting, profitable and unusual opportunity. Mail this coupon now!

ROCFORM CORPORATION
HOME OFFICE & FACTORY
15160 W. 8 MILE ROAD
DETROIT 35, MICHIGAN

Please rush me full details on how I can become your partner in this fast-growing business of forming better, more economical concrete walls with Rocform Systems.

NAME _____

ADDRESS _____

CITY _____ ZONE _____ STATE _____

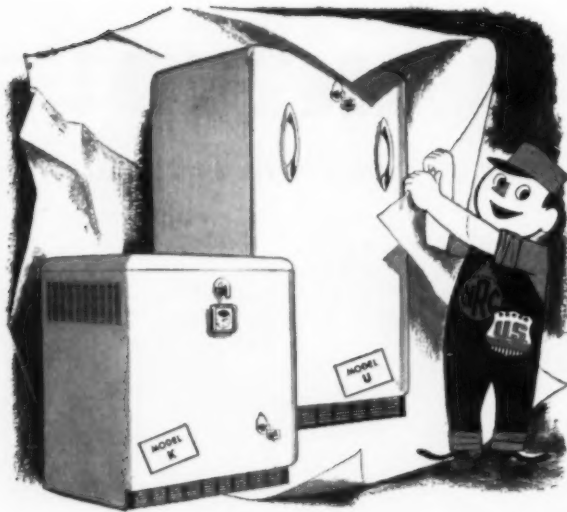

Profit with Packets...

THE NATIONAL-U.S. PACKET all-in-one...automatic HOME HEATING UNIT

Low Installation Costs. Each National-U.S. Packet is factory-assembled and shipped as one unit comprised of the burner, boiler, domestic water heater, controls, and all accessories. Only simple connections are required.

Elimination of Separate Water Heater. The built-in domestic water heater eliminates the need for a separate water tank and heater with attendant installation costs.

Efficient Utilization of Space. Compact size conforms to the modern practice of utilizing space with utmost efficiency.

Priced Economically. Low first cost makes the National-U.S. Packet suitable for homes priced within the budget range of most buyers.

Choice of Heat Distribution Methods. Packets permit a wide choice of heat distributors such as: radiant panels, National-U.S. baseboards, convectors, radiators, or unit heaters.

Satisfied Customers—Ready Prospects.

National-U.S. Packets provide the heating comfort, heating economy and domestic hot water that home-owners need and enjoy. They're designed in smart appearing white enameled jackets that harmonize with the decorative scheme of the modern laundry, playroom, kitchen, and utility room.

Code Constructed and Rated—
Insurance Company Inspected.



Write for bulletins
on National-U.S.
Packets and Heat
Distributors.



National-U.S. Radiator
CORPORATION

HEATING AND AIR CONDITIONING DIVISION
Johnstown, Pennsylvania

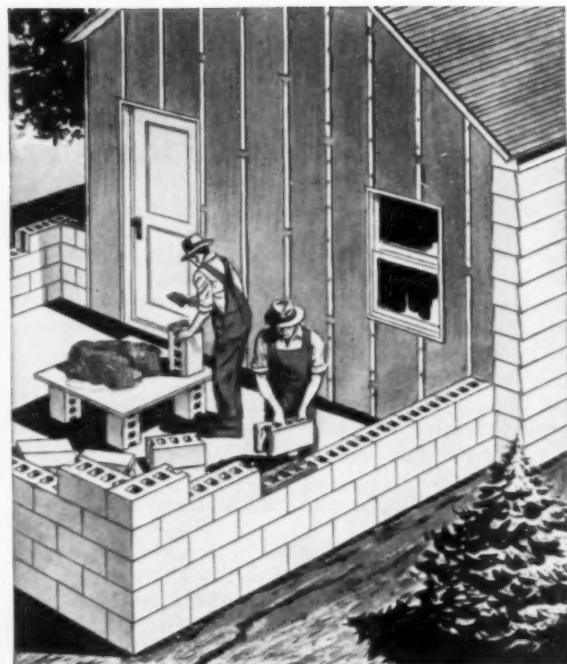

Get *Your* share of the \$8 Billion Remodeling Market

Want profitable remodeling work? Consider the forces creating demand for such construction:

1. Millions of houses, commercial, industrial and farm buildings built before the depression need renovating to extend their useful life.
2. Millions of families bought minimum houses after World War II. These families now have grown; they need larger, expanded houses.
3. U.S. population, increasing 7000 daily, needs more new buildings—and enlarged, remodeled old buildings in which people live, work, shop, play and worship.

Capitalize on these forces by seeking remodeling business. And remember, concrete masonry remodeling satisfies everyone. To the builder it means fast, easy construction. To the owner it means durable, firesafe, ratproof, rotproof, termite-proof, *low-annual-cost* buildings.

For helpful information on concrete masonry construction, write for free "*Concrete Masonry Handbook*," distributed only in U.S. and Canada.

PORTLAND CEMENT ASSOCIATION

Dept. 7-3, 33 West Grand Avenue, Chicago 10, Illinois

A national organization to improve and extend the uses of portland cement and concrete... through scientific research and engineering field work

WOULD YOU SPEND \$29 TO SELL A HOUSE FAST?

Weldwood Paneling gives you a feature women want —



SLICED WALNUT paneling makes an impressive background for contemporary furnishings. And a 12' x 8' wall costs only \$70. Matching shadow box makes fireplace wall a permanent focal point.



AMERICAN CHERRY paneling's warmth sets off traditional perfectly. V-Plank* paneling ("v-grooved" for a plank effect) costs only \$80 for a 12' x 8' wall. Plan #1583 for desk-bookcase and turntable compartment.



PHILIPPINE MAHOGANY Plankweld paneling turns attic waste space into a handsome bedroom for a boy . . . costs but \$60 for a 12' x 8' wall. Desk top is of durable Micarta®, installed with Weldwood Contact Cement.



SEA SWIRL® paneling gives a cheerful look to a breakfast nook—costs \$29 for a 12' x 8' wall. Weldwood birch cupboards and Micarta work surfaces make the room handsomely informal, beautifully practical.



Weldwood®

REAL WOOD PANELING

UNITED STATES PLYWOOD CORPORATION

*Trade Mark **Reg. and Patented

NEW HOME DECORATING BOOK

United States Plywood Corporation
55 West 44th St., New York 36, N. Y.

AB-7-56

Please send new Weldwood Decorating book, showing Weldwood paneling and paneled rooms in beautiful full color.

NAME.....
COMPANY.....
ADDRESS.....
CITY.....STATE.....

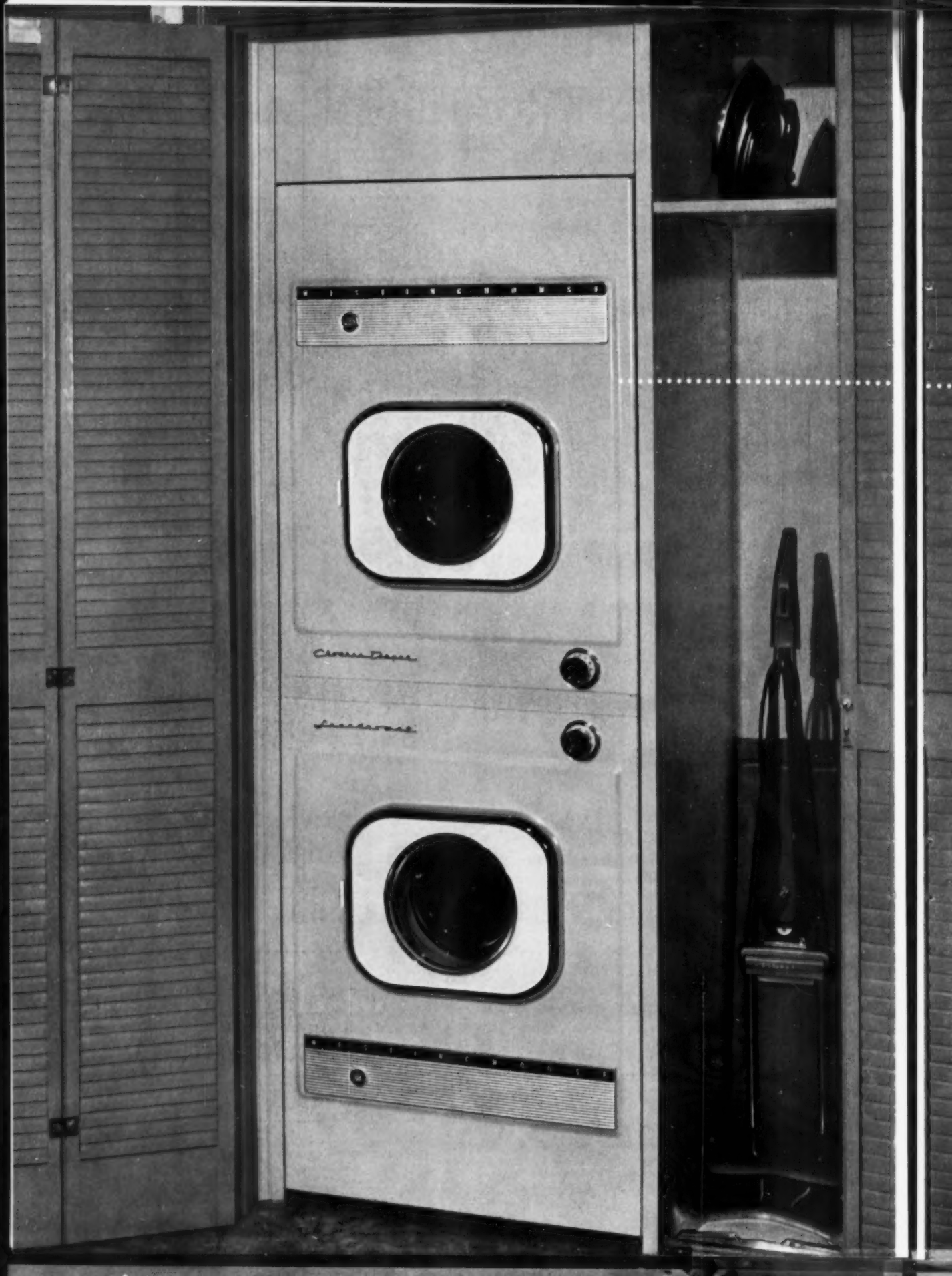

NEW...WESTINGHOUSE...EXCLUSIVE...!

Complete Built-in HOME LAUNDRY IN 25 INCHES

Built-in Space-Mates install vertically

Westinghouse introduces an exciting new 25" wide Laundromat and matching 25" wide Clothes Dryer. The Dryer sits on top of the Laundromat in unique, vertical installation . . . provides a complete home laundry in minimum space.

Both models are completely automatic . . . will wash and dry a full family-size load of clothes. They are also available in free-standing models and in all of the new Westinghouse Confection Colors.

Undercounter Installation—Built-in Space Mates also install under custom counter surface for side-by-side use.



Deluxe Laundry Twins—America's favorite free-standing twins, the deluxe Laundromat and Clothes Dryer are shown adjacent to the kitchen. Both models have new Color Glance Controls plus many other deluxe features.



All models shown are available in new Confection Colors

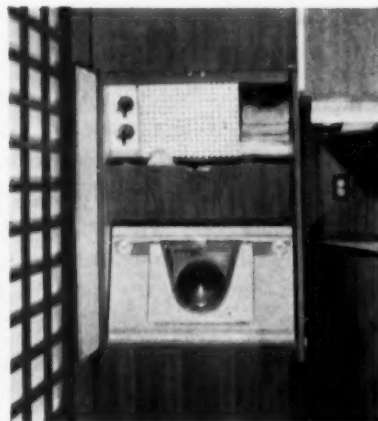

Wash 'N Dry Laundromat—First it washes . . . then it dries, all in a single, space-saving unit, 32" wide. Has Weight-To-Save Door and Water Saver for economy, flexible controls and automatic operation. Can be built into closet or alcove as shown.



See your Westinghouse Distributor for complete details on Westinghouse Laundry Equipment, or write direct to our Contract Sales Department.

WATCH WESTINGHOUSE
WHERE **BIG THINGS ARE HAPPENING FOR YOU!**

Westinghouse Electric Corporation, Major Appliance Division, Mansfield, Ohio

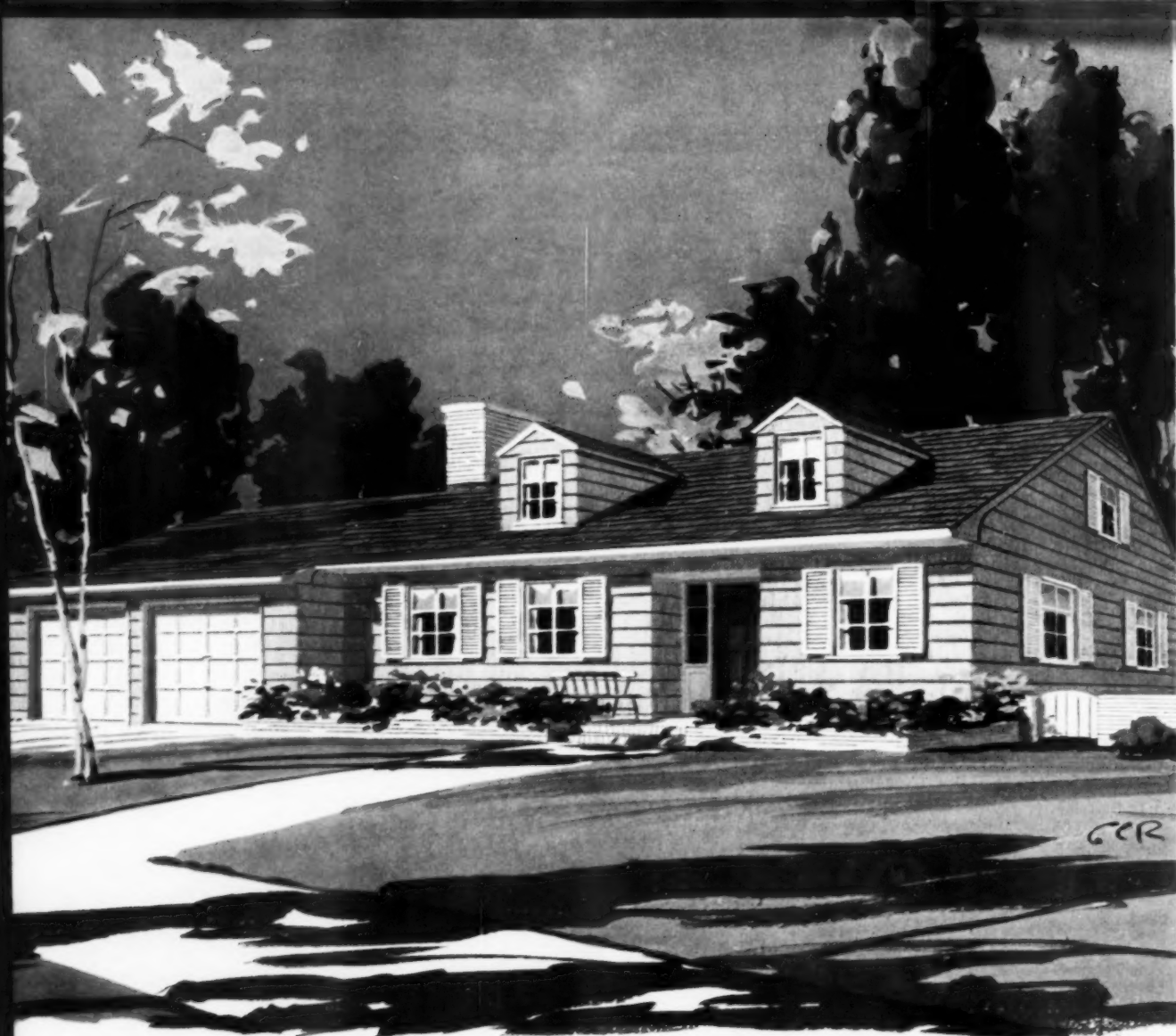

Designed by George Cooper Rudolph, A.I.A.

MODERN ASBESTOS GIVES A TRADITIONAL DESIGN

Lasting Beauty

Buyers will find double appeal in the asbestos sidewalls of this traditional Cape Cod design. Undercoursed asbestos siding gives a trim, clean exterior with eye-catching shadow lines. Asbestos-cement is rotproof, weatherproof — needs no protective covering, almost no upkeep, and may be painted to change the color scheme when desirable. For a powerful sales extra, consider the asbestos roof, too — providing top-to-bottom fire protection for the buyer with a family. For more information on asbestos-cement products, write today for your free copy of "Advanced Designing . . . 1956."

ASBESTOS-CEMENT PRODUCTS ASSOCIATION

509 MADISON AVENUE, NEW YORK 22, N. Y.



The 1956 Remodeling Opportunity

Home improvement—which means timely maintenance as well as room-by-room modernization—should have the same economic relationship to the home building industry that the service and repair station have to the automobile industry.

The automobile industry sells obsolescence deliberately and aggressively. But it sells obsolescence in styling more than performance. Indeed, the industry does everything it can to induce owners to keep older models at a high peak of mechanical performance. This double-play makes it possible to offer compelling trade-in deals to new-car prospects and then be assured of quick turnover for the trade-ins in the used car market.

Our home building industry today has reached the point that every economist knew we would reach in 1956 or 1957. We have resolved all semblance of a housing shortage. In doing so we have built an industry capable of producing more than one and one-quarter million new housing units a year. Suddenly the demand is for less than that total.

It has now become necessary to create new prospects through merchandising. Those prospects are the owners of old houses, houses too small for expanding families, houses too modest for increased incomes, houses too large for elderly couples. But they must be cultivated. That means aggressive obsolescence-selling, trade-in deals and the creation of an active used house market.

At the beginning of such a program, of course, most of the trade-in houses will have to be remodeled for easy resale. That's one reason why we have made this a special issue on remodeling, beginning on the next page. It's also why we ran an 8-page special report on "remodeling for profit" in our May issue.

One thing more: it has been argued that trade up selling or obsolescence selling eventually must leave a large number of houses unused. That is all to the good. There are many millions of houses in this country that no family should be expected to live in. If we can trade up to a point where we automatically eliminate the need for housing families in sub-standard structures we will have gone far toward solving both an economic and a social problem.

Ed Harin

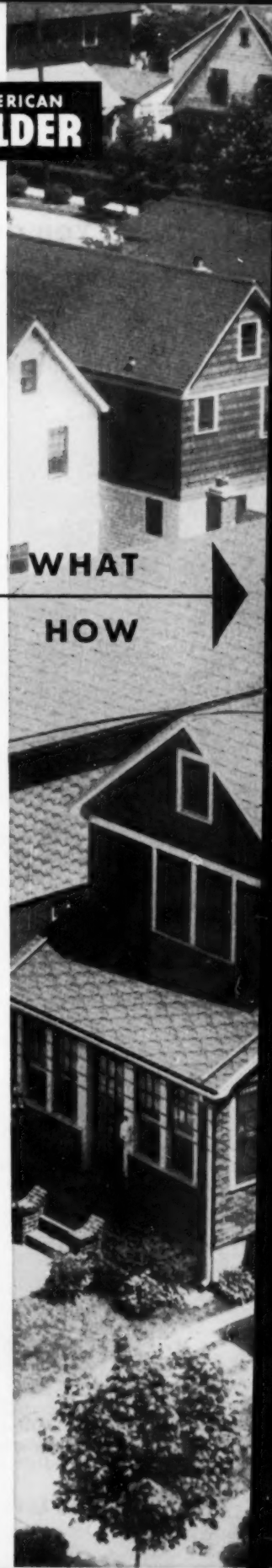

How to make

▼ YOU CAN COOL IT ROOM BY ROOM



WHAT In many Northern areas there is little need to cool the whole house, but individual rooms can be made comfortable with units such as this, made by Lewyt. Check reply card No. 7001, p. 148.



HOW Opening, $\frac{1}{4}$ -in. larger all around than the actual unit size, is marked off. Masking tape is put on to minimize plaster chipping, and inside wall is then cut out. Bayonet saw is best tool.



HOW After first brick has been removed with $\frac{1}{4}$ -in. drill, the rest are chiseled out. Wood siding would make job even easier. Next step is to saw out jack studs under the window sill.



HOW The sleeve casing is fitted into wall opening. In some cases additional sill member may have to be installed under the window, providing an extra margin of safety against window sagging.



HOW After sleeve casing is screwed in place, tar paper and filler are put around edge for a tight seal. Final installation is neater, more permanent looking than usual window installation.

a hot house a cool house

▼ YOU CAN COOL THE WHOLE HOUSE

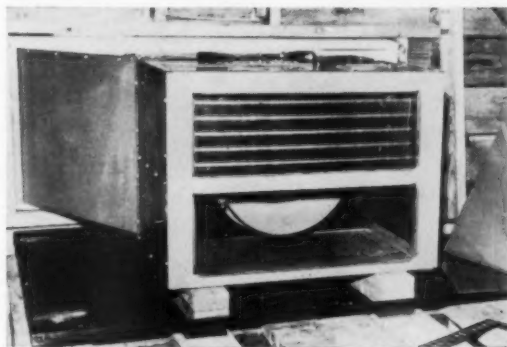

VORNADO is the manufacturer of this easily installed attic cooling unit. Check reply card No. 7002, p. 148.



PACKAGE by Carrier can be installed in almost any spot with minimum ductwork. Check reply card No. 7003.

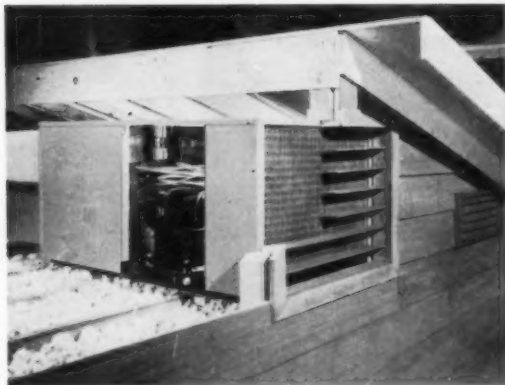

CUTAWAY view shows how Lennox horizontal unit will fit a low attic. Check reply card No. 7004, p. 148.

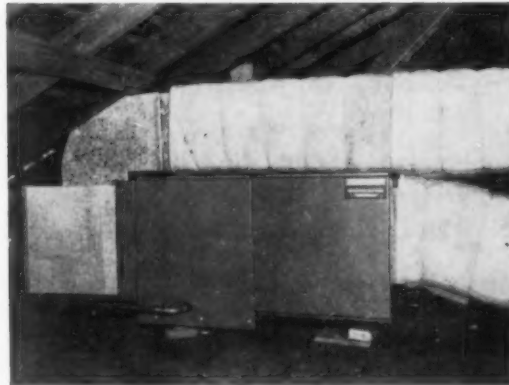

THIS 5-ton unit by Worthington is designed for either attic or basement. Check reply card No. 7005, p. 148.

▼ HOW TO INSTALL WHOLE HOUSE COOLING

Air conditioning poses both an opportunity and a challenge to the remodeling contractor. Unlike the newer warm air heating systems, older systems were generally not designed for air conditioning; wet heating systems provide no ductwork for the remodeler to work with. Particularly in one story houses, the attic installations shown here will probably provide the least expensive answer.

Relatively short lengths of duct can be run directly over rooms and exhausted through the ceiling; they must be carefully insulated, however, or operating costs may be high. In some two story houses, the installation of two units, one in the basement and one in the attic, might be the best answer.



MODEL of Philco attic unit with new, easily installed fiber glass ducts. Check reply card No. 7006, p. 148.

How to put

▼ NEW HEATING IS COMPACT: SLIDE IT UNDER



WHAT Remodeling an old house almost always calls for a new heating plant; an addition may require a unit of extra capacity. Unit shown is made by Coleman. Check reply card No. 7007, p. 148.

New ductwork is smaller, lighter, easier to handle, too . . . which makes an installation like the one shown here a cinch

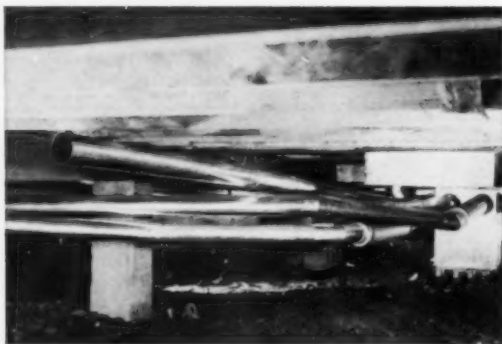

HOW Small diameter metal duct is run to spot where registers will be cut through. One duct is left open to provide warmth in the crawl space, which in turn will heat floor above, increase comfort.



HOW Crawl space installation starts with mounting on concrete block. Hanging from joists might cause unpleasant vibrations in the house. Unit is vented to old flue, first fittings connected.



HOW A short length of insulated fiber duct is installed in each line near furnace. This is acoustical insulation, and serves as a sound trap to muffle noise of the blower and the burner.



HOW Small blender type registers are inserted in openings cut for them. They are close to the wall, inconspicuous. Job of this type should be completed in a maximum of two days, by two men.

new warmth into old houses

▼ NEW HEATING IS VERSATILE: PUT IT ANYWHERE

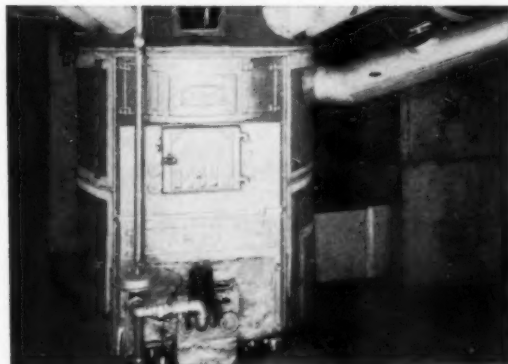

BEFORE Typical of older furnaces is this unit. Good for its day, by modern standards it is oversized, dirty, unattractive, and inefficient.

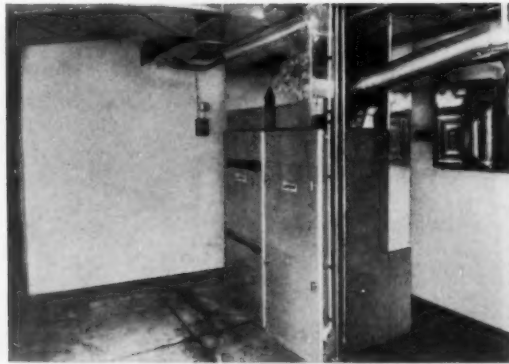

AFTER The same house with a new Janitrol forced air furnace. It is compact, attractive, far more economical. **Check reply card No. 7008, p. 148.**



WHAT Finned convactor tubing, made by Kritzer Radiant Coils, Inc. **Check reply card No. 7009, p. 148.**

HOW Installed under floor joists, the coils keep floor above warm, also heat the basement.

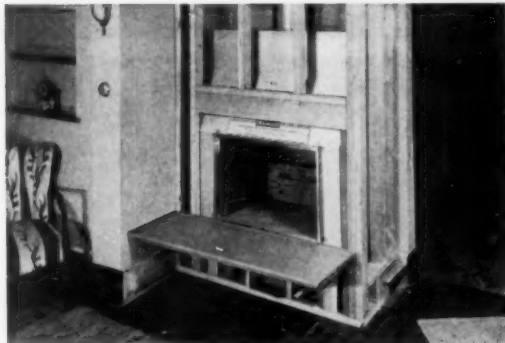

WHAT Thulman packaged fireplace is manufactured by Majestic. **Check reply card No. 7010, p. 148.**

HOW Unit can be installed almost anywhere, has light-weight flue that needs no masonry.



WHAT Van Packer packaged chimney for fireplaces and furnaces. **Reply card No. 7011, p. 148.**

HOW Flue sections are quickly and easily installed, are then topped off with simulated brick cap.

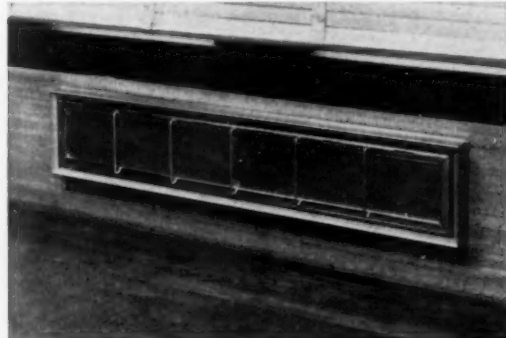

WHAT Radiant glass electric strip heater is 240 volts, 1000 watts. **Check reply card No. 7012, p. 148.**

HOW Designed for extra warmth in bathrooms, or any cold spots that might occur throughout the house.

How to wrap

ON THE SURFACE: GOOD LOOKS, DURABILITY



WHAT American Colonial asbestos shingles, made by Johns-Manville. Check reply card No. 7013.

HOW New shingles are applied directly over the old roofing, are fireproof, look like wood shingles.



WHAT Upon primed siding, 12 inches wide, lapped one inch. Check reply card No. 7014, p. 148.

HOW Installation is the same as any beveled siding. Prepriming eliminates costly first paint coat.



WHAT Shadowvent, a hardboard horizontal siding by Masonite. Check reply card No. 7015, p. 148.

HOW Aluminum strips under butt end are vented to let moisture escape, give attractive shadow line.



WHAT Colorbestos shingles and shingle backers by Johns-Manville. Check reply card No. 7016.

HOW Integrally colored shingles nailed over backers that deepen shadow line, give added insulation.



WHAT Redibrik veneer is 1/2 inch thick, 16 inches long. Check reply card No. 7017, p. 148.

HOW Pieces are cemented on right over existing walls, can be bought in fifteen different colors.

a new surface around the house

▼ UNDER THE SURFACE: HEAT CONTROL



Certain-teed pouring wool insulation is made of Fiberglas by Owens-Corning Corp. **Reply card No. 7018, p. 148.**



Lumaskin, by Angier Corporation, combines vapor barrier and insulation. **Check reply card No. 7019, p. 148.**



Series of aluminum sheets, with air spaces between, in Infra Accordion insulation. **Check reply card No. 7020, p. 148.**



Super Sealfoil, by Sealtite, is a glass fiber blanket wrapped in aluminum. **Check reply card No. 7021, p. 148.**

HOW TO PICK THE RIGHT INSULATION FOR THE JOB

There are many different types of insulation, each designed to do a specific job in a price range. To recommend the right type, the remodeling contractor must have a working knowledge of how different insulating materials do their work.

Mineral wool or glass fiber are excellent insulators for conducted heat. They can be poured between ceiling joists, blown into walls, or nailed up in batts that provide vapor barriers on the inside. Aluminum foil or aluminum coating makes the best insulation for radiant heat; it will reflect a high percentage of heat

away from its surface. Naturally, a combination of the two types is most efficient, and generally the highest in cost.

The roof is the critical area for heating and cooling insulation. Wool or glass will prevent heat from escaping through the ceiling, aluminum surfaces will reflect away heat that might otherwise gradually heat up the attic space. For maximum efficiency of year-round air conditioning, sidewalls too should be insulated. This will often permit use of a smaller heating plant in an old house.

How to dress up

▼ FINISH OFF THE ATTIC WITH WOOD WALLS



WHAT The expansion attic is one of the most widely remodeled areas; these pictures by the Western Pine Association show how natural wood walls can transform it. **Reply card No. 7022, p. 148.**



HOW First, knee wall studs are put up. Insulation is put in, and then any rough wiring and plumbing that is required. Finally, furring strips are nailed up horizontally to receive boards.

1



HOW Vertical wall boards are nailed into place along the furring strips. Middle furring piece adds rigidity to wall, but with tongue and groove construction it is not absolutely necessary.

2



HOW Corner board is set in place. To make a neat looking joint, groove end of board is planed or ripped past the V-bevel, and then, if necessary, scribed to fit the other wall accurately.

3

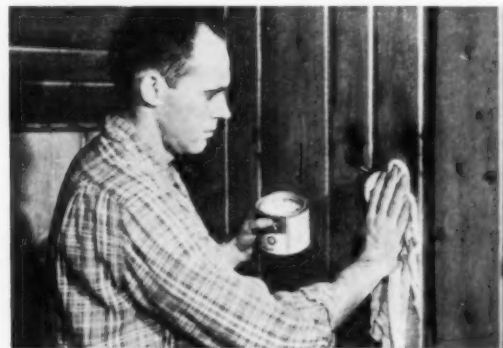

HOW Finishing is the final step, offers limitless decorating opportunities. Wax protects the wood, can be used to darken it slightly. Many stains are available to add color, preserve texture.

4

old walls with new surfaces

▼ RESURFACE OLD WALLS WITH MAN-MADE MATERIALS



WHAT Duro-lite Plank is 16 in. wide. Manufactured by Insulite. Check reply card No. 7023, p. 148.

HOW With material of this type the contractor can offer his customers substantial savings in wall remodeling. Existing walls are left as is, nailing strips added, and new wall nailed up.



WHAT Leatherwood, a Masonite Presdwood with a leather texture. Check reply card No. 7024.

HOW Hardboard wainscoating is an attractive wall remodeling material. It is especially good to cover up battle scars in children's rooms, makes a tough, hard-to-damage surface.



WHAT Celotex Finish Plank comes already finished, is made of cane fiber. Check reply card No. 7025.

HOW Wallboard panels such as these come with shiplap joints which permit the use of a fast-acting stapling gun to put them up. The material also acts as an insulator and a sound deadener.



WHAT Tee-N-Gee panels, made by Forest Fiber Products Company. Check reply card No. 7026, p. 148.

HOW These panels can be installed either vertically as shown, or horizontally. Notice that furring strips at the bottom are closer together. Any impact probably will occur in that area.

How to surface

ON THE WALLS: VARIETY OF CHOICE



WHAT Marlite plank (left wall) and Marlite block (right wall). Check reply card No. 7027, p. 148.

HOW Walls are hardboard covered with an easy-to-clean plastic, are nailed up with special fittings.



WHAT Gold Seal Congowal is made by Congoleum-Nairn. Check reply card No. 7028, p. 148.

HOW This wall covering comes in rolls, is made to simulate colors and designs of ceramic tile.



WHAT Consoweld 10 wall panels, Roltite mastic for Consoweld 10. Check reply card No. 7029, p. 148.

HOW Consoweld is shown being installed over masonry block. The large sheets go up with top speed.

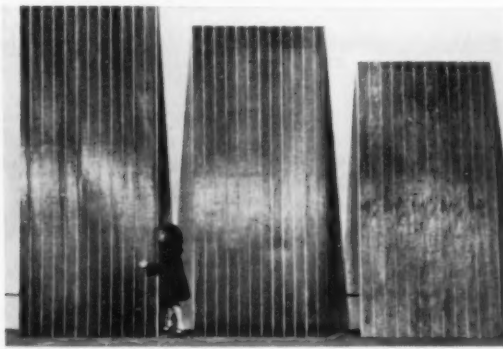

WHAT Malarkey Rusticwood, by the M and M Woodworking Co. Check reply card No. 7030, p. 148.

HOW These texture III type redwood panels make good looking interior paneling, are easily installed.



WHAT Silitex, F. X., masonry sealer, Siliphane Corporation. Check reply card No. 7031, p. 148.

HOW This silicone paint is applied in two coats, will waterproof concrete and block walls.



WHAT Amerwood prefinished wood paneling. Check reply card No. 7032, p. 148.

HOW This interior paneling is made distinctive by its etched texture, is applied like any wood wall.

interior walls with little effort

▼ ON THE CEILING: EASY TRANSFORMATION . . .



Armstrong Acoustical Ceiling Tile is being attached with adhesive. Check reply card No. 7033, p. 148.



Fiberlite Tileboard ceiling, made by Insulite, is applied with mastic. Check reply card No. 7034, p. 148.



Celotex Tile Board ceiling is stapled to furring strips. Check reply card No. 7035, p. 148.

Glazecoat Wall Plank ceiling by Johns-Manville. Check reply card No. 7036, p. 148. ▶



▼ SMALL TILES: LIGHT AND HANDY

The ceilings shown here might be called triple threats. They serve as attractive finishes, sound deadeners, and partial insulators. All of the pieces are small, an important factor to the man who has to lift them up to ceiling height. And they are all easy to put up.

There are two methods of installing ceilings of this type. When an existing ceiling is to be redone, the panels can be stuck right to the old ceiling with adhesive. Where no ceiling exists, as in an unfinished basement or attic, furring strips are nailed up at right angles to the joists, and the new ceiling panels attached with stapling guns.



Going up here: a Marlite Korelock ceiling by Marsh Wall Products, Inc. Check reply card No. 7037, p. 148.

How to build

▼ PUT WOOD FLOORING OVER THE SLAB



WHAT Wood flooring is still the most popular with Mrs. Housewife. The National Oak Flooring Mfg. Assoc. shows here how oak strip floor is applied on a slab. Check reply card No. 7038, p. 148.



HOW
1 Mastic is spread on concrete. It is important that a tight vapor barrier be installed. If it is not already under the slab, it should be put on top of the screeds, right under the flooring.



HOW
2 Nailing screeds are set in the mastic. Note how they are staggered, and how random lengths are set. Only flat, dry timber should be used. Gap at screeds and shoe allows for floor expansion.



HOW
3 Flooring strips are laid at right angles to the screeds, ends are nailed to the shoe, as shown. For this purpose it is a good idea to use an extra wide shoe timber—either 2 x 6 or 2 x 8.



HOW
4 Where a floor strip crosses overlapped screeds, it should be nailed to both screeds for greatest strength. Joints need not break over screeds but no two joints should be over same screed space.

in beauty underfoot

▼ USE THESE MATERIALS FOR NEW DURABILITY



WHAT Terraflex vinyl asbestos flooring, by Johns-Manville. Check reply card No. 7039, p. 148.

HOW This tough material provides durable floor at low cost. Brush-on adhesive is being used here.



WHAT Oak block parquet flooring is manufactured by Bruce. Check reply card No. 7040, p. 148.

HOW In this type of installation, the oak floor is set directly in the mastic without nailing screeds.



WHAT Hardboard floor underlayment, manufactured by Masonite. Check reply card No. 7041, p. 148.

HOW Finish flooring is only as good as its subfloor. Smooth underlayment assures a smooth tile floor.



WHAT Markwa marble floor tile, Vermont Marble Company. Check reply card No. 7042, p. 148.

HOW Marble tile floor provides a luxury touch at low cost, comes in three sizes, 18 color combinations.



WHAT Gold Seal Linoleum flooring is by Congoleum-Nairn. Check reply card No. 7043, p. 148.

HOW Linoleum is still the most economical flooring; its long lengths are quickly pasted in place.



WHAT Hako cement for asphalt tile is by Hachmeister Inc. Check reply card No. 7044, p. 148.

HOW Ease of installation is one of tile flooring's big advantages. Here a comb trowel is being used.

How to bring

BUILD AN ADDITION WITH WALLS OF WINDOWS

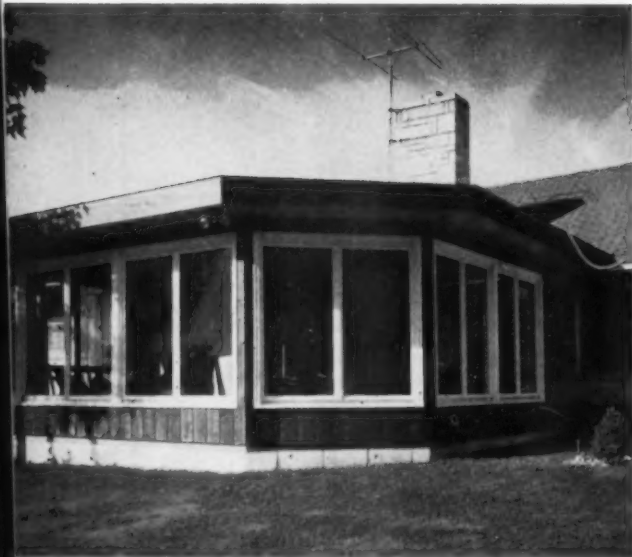

WHAT Chief attraction of this newly-added family room is the tremendous glass area on two sides. Windows are horizontal gliding units by Andersen. Check reply card No. 7045, p. 148.

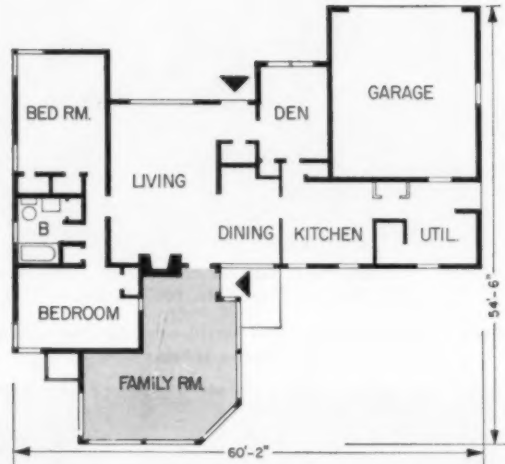

HOW The floor plan shows how the new room's position was picked in relation to the rest of the house. On a job like this, the contractor's best sales gimmick is to let the windows sell the whole job.

**When you build on a room,
bring in light and air
with better window engineering**



HOW Sliding sash units of this type window are easy to take out of cleaning. Another idea: in the summertime, put in the screens, take out the sash, and the room becomes a big, open porch.



HOW The window frame is set into the rough opening. Today's windows are industrial products of very high dimensional accuracy. If the builder does his work well, installation is quick and easy.

new brightness inside

▼ USE WINDOWS OF ALL SIZES AND SHAPES

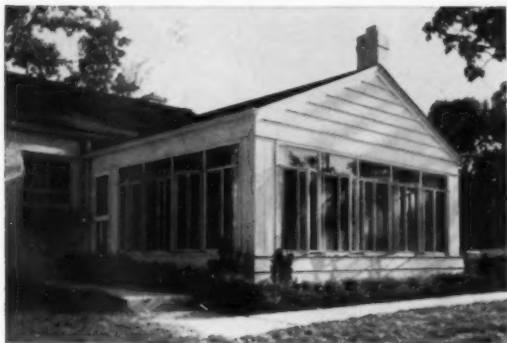

WHAT Steel casement windows from Ceco Steel Products Corporation. Check reply card No. 7046.

HOW Set up side by side, these steel units form an attractive and very strong glass wall.



WHAT Bilt-Well Awning Windows, By Carr, Adams and Collier Co. Check reply card No. 7047, p. 148.

HOW These individual units can be stacked together in many different sized window wall sections.

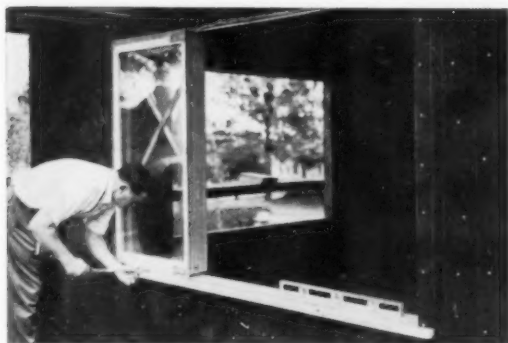

WHAT Wooden casement windows manufactured by Pella. Check reply card No. 7048, p. 148.

HOW These windows can either go up as a window wall, or as flanking units for a picture window.

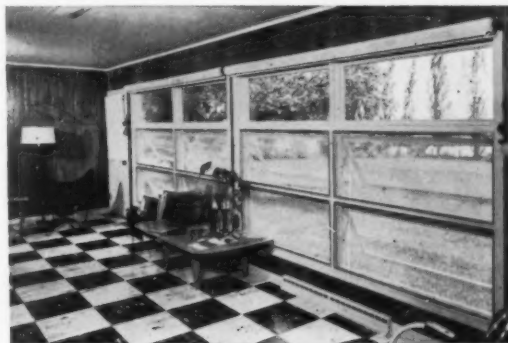

WHAT Awning windows are Curtis Silentite Convertible units. Check reply card No. 7049, p. 148.

HOW Window walls are a fine way to handle an on-grade basement wall. Top sash row is fixed glass.



WHAT Three-unit awning window by Gate City Sash and Door Company. Check reply card No. 7050.

HOW All three awnings can be opened together in such a window. Here it flanks large fixed pane.



WHAT BeeGee wood casement window, made by Brown-Graves Company. Check reply card No. 7051.

HOW Unit includes both fixed and operating sash. Storm sash can be added to open with casement.

How to let in

LET IT IN THROUGH THE ROOF



WHAT There are some rooms, like this inside bath, that can only be lighted through the roof. The plastic skydome is manufactured by Wasco Products, Inc. Check reply card No. 7052, p. 148.



HOW Position of skylight is determined from the inside, and the measurements transferred to the roof. When the actual cut is to be made, it should break through only one roof rafter.

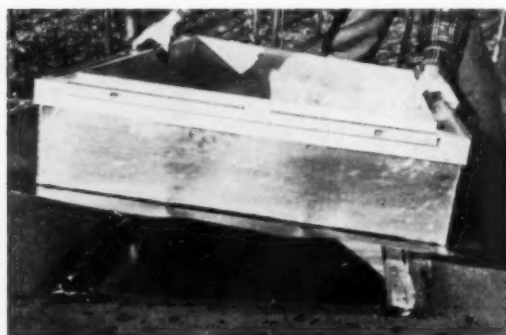

HOW Skylight box is set down over the cut opening. Note the flashing already in place on the box. The roof joint is the only one made by the builder; all other joints are factory made.



HOW Plastic skydome is set on the box. This material is virtually shatterproof, has extremely high structural strength augmented by its dome shape. It is much better insulator than standard glass.



HOW Final step is the installation of a gasketed rim to hold down the plastic dome. These skydomes are available in many other sizes and shapes, can have opaque as well as clear plastic.

light from every direction

▼ LET IT IN FROM FLOOR TO CEILING



BEFORE: By the standards of yesterday this wall has a lot of windows. But the overall effect is that of a lot of clutter, and the amount of light let in surprisingly little. Construction of this wall was complicated too.

AFTER: The same room following a remodeling job in which the whole wall was ripped out and Arcadia steel sliding doors installed. The whole room has changed, seems a part of the outside. Check reply card No. 7053, p. 148.



▼ . . . AND BUILD LIGHT INTO NEW ROOMS



WHAT Sixteen foot sliding glass door is by Steel-Built. Check reply card No. 7054, p. 148.

HOW In an addition like this construction is virtually post-and-beam, sliding unit carries no load.



WHAT Sliding glass doors manufactured by Arislide. Check reply card No. 7055, p. 148.

HOW These units are made of either steel or aluminum, are weatherstripped, slide on nylon rollers.

How to

▼ THEY GO UP FAST—THIS ONE TAKES 7 MINUTES

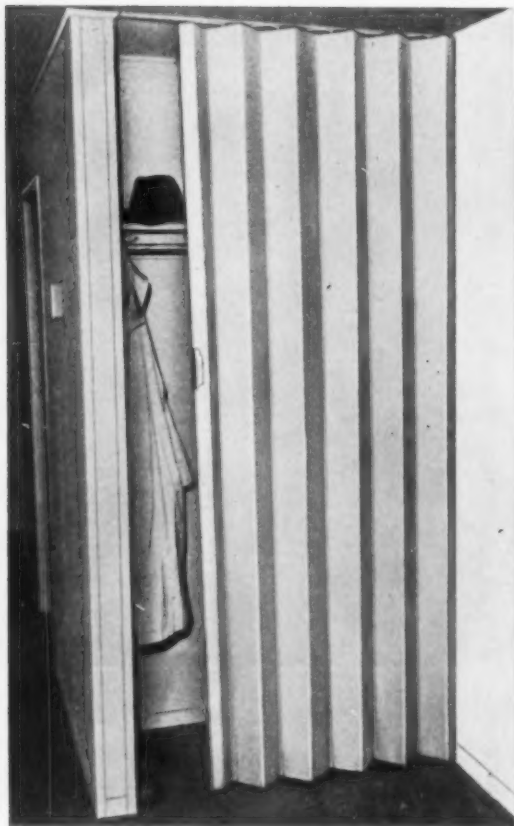

WHAT Folding doors like the one above can save as much as 8 square feet of floor space. Accordofold (American Bamboo Corporation) is of vinyl plastic. Check No. 7056 on card, p. 148.



HOW Center and fit metal track to top of door opening. Mark off screw holes, punch holes to start screws. Door folds to 16 per cent of its extended length, has 4½ in. width.

1

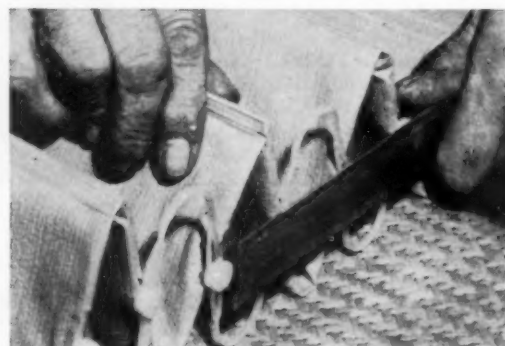

HOW Place door on flat surface and slide nylon glides on door into track. Keek folds partially open until center of track is reached. Nylon slides are self-lubricating, make for easier maintenance.

2



HOW Determine direction of door opening. Hold door and track as a single unit and attach track to top of opening. Be sure to attach center screws first. Center door on the track carefully.

3



HOW To fasten door, drill 4 holes in anchor flap against wall. Screw into wall. Close door. Make sure lead rail is plumb and mark off on wall. Screw to wall between markings.

4

remodel with new doorways

▼ THEY MULTIPLY OR DIVIDE SPACE



WHAT Problem: What should you do with a large room to make it flexible as either one or two rooms?

HOW Use Folddoor Beautyline (Holcomb & Hoke) Door to open room. **Check No. 7057, p. 148.**



WHAT Problem: To hide storage space and do the job quickly and simply, yet attractively, too.

HOW Use a Ra-Tox Fashionfold basswood folding door (Hough Shade Corp.) **Check No. 7058, on p. 148.**



WHAT How to eliminate door conflict in hallways and corners, and save wall space at the same time.

HOW Use a sliding door like New Castle Products' "Modernfold." **Check No. 7059, p. 148.**



WHAT What should you use when adding a room, finishing an attic or to replace old doors?

HOW Use the "Ready Hung Door" that is a packaged unit with frame and door complete. **No. 7060.**

How to

▼ SHOWER DOORS GIVE IT A NEW LEASE ON LIFE



WHAT Installation of a shower-tub enclosure, like the one above, (Shower Door Company of America) is a great asset to the remodeling of a bathroom. Check No. 7061 on p. 148.



HOW 3 Make wall-to-wall measurement above jambs so that top header can be cut to exact dimensions. Insert panels in header, where they roll on life-time bearings.



HOW 1 Check alignment of tub and walls. Secure bottom guide on tub rim with Shodoco's S-18 adhesive that acts as a calking agent and adhesive. Slant guide toward inside of the tub.



HOW 2 Secure wall jambs to wall with same adhesive. Wall jambs interlock with bottom guide at the tub rim. No screws are used in installation of this Permalume tub enclosure.



HOW 4 Lift header and panels into place at top of wall jambs, in interlocking fashion. They will be held there by weight of panels. Installation of shower door is complete.

up-date an old bathroom

▼ IT'S THE EXTRAS THAT BRIGHTEN A BATH



WHAT To inspire new life into the bathroom recover the walls with tile.

HOW Apply plastic wall-tile cement and tile like "Hako Coronet." **Check No. 7062, p. 148.**



WHAT New beauty for old bathroom walls with "Miraplas" wall tile. **Check No. 7063, p. 148.**

HOW Clean the wall surface, lay out job starting at the top, apply cement to wall and set tile.



WHAT To get that "custom-bath" look for an old bathroom, try using a built-in shower curtain.

HOW Install a "Tub-Master" folding shower enclosure by New Castle. **Check No. 7064, p. 148.**



WHAT Shatterproof fiber glass and aluminum to renew a bathroom with newborn vitality.

HOW Install a Leigh "Shower Queen" bath enclosure by Air Control Products. **Check No. 7065, p. 148.**

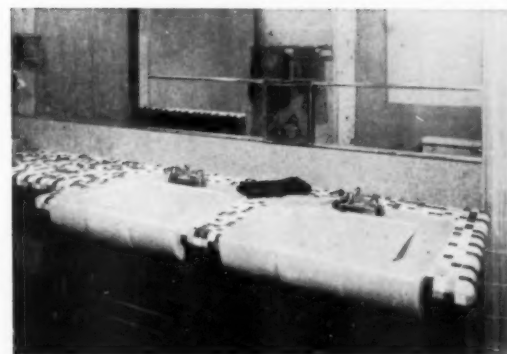

WHAT Replace old fixtures with new ones. Above, lavatories are set in ceramic tile counter.

HOW Use new fixtures like those of Richmond Radiator Company. **Check No. 7066, p. 148.**



WHAT New fixtures bring a bathroom up to date; are essential to a thorough remodeling job.

HOW Replace fixtures with American Standard's new bathroom line. **Check No. 7067, p. 148.**

How to

▼ NEW CABINETS CREATE THE CHANGE IN THE KITCHEN . . .



WHAT This remodeled kitchen reflects the care and precision that went into the planning and arrangement of old space. Cabinets are from Republic Steel Kitchens. Check No. 7068, p. 148.

The kitchen has priority for remodeling attention—update it, or that one room will give away the whole job



HOW Doublecheck cabinet layout by marking off the space needed for each cabinet on walls. Later, by following this layout, you are certain to install each cabinet in its proper place.

1



HOW Install cabinets by one of two methods: either by anchoring to wall studs or to furring strips. Use 2" No. 10 oval lid wood screws for stud, 1" No. 12's for strip installations.

2



HOW Fillers are used to fill space which cannot be utilized by cabinets. Republic fillers have pre-drilled holes that line up with upright holes in the wall cabinet.

3



HOW Install counter cabinets starting from the corners and working toward the ends. Secure counter cabinets to studs with 2" No. 10 wood screws, bolt together through uprights.

4

remodel your most important room

▼ . . . AND APPLIANCES WORK WITH THEM FOR BETTER TRANSFORMATIONS



BEFORE: "Architectural guinea pig" kitchen was part of "Operation Demonstrate" program in Cleveland.



AFTER: Transformation is complete. Frigidaire kitchen has a complement of modern electric appliances for homemaker's convenience. Shown are work area, dishwasher, sink and refrigerator. **Check No. 7069, p. 148.**



BEFORE: Farm house kitchen shown here was in house about 100 years old. New equipment is shown at right.



AFTER: Farm house kitchen takes on a new lease on life as seen in photo above. New Tracy Kitchen (Edgewater Steel Company) transforms it into workable space. **Check reply card No. 7070 on p. 148.**



BEFORE: Installation of new General Electric wall refrigerator, one wall of this kitchen looked like this.



◀ **AFTER** installation of wall-hung refrigerator, which hangs on a 5-foot mounting bracket bolted to wall studs. Unit is 64" long, 39½" high and 17½" deep. **Check No. 7071 on card, p. 148.**

**FOR MORE KITCHEN
REMODELING IDEAS
SEE NEXT PAGE ▶**

How to install

▼ BUILT-IN OVENS AND RANGES TO UPDATE COOKERY



WHAT Workman, above, is installing a Norris-Thermador cooking top in kitchen countertop. Unit shown is the "SU-4CN" model. For more information about this model, check No. 7072 on p. 148.



HOW To install Model SU-4CN, hole in countertop should be cut $28\frac{3}{4}$ " long and $20\frac{3}{4}$ " wide. Cooking top is $29\frac{1}{4}$ " x $21\frac{3}{4}$ ", is $10\frac{3}{4}$ " deep. Unit has connected load of 5700 watts.

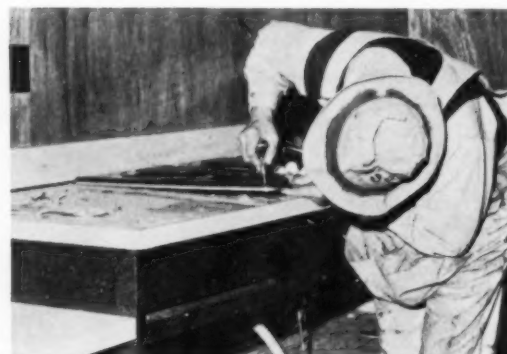

HOW Use flexible metallic conduit, flexible non-metallic cable or armored cable for feeder circuit. Hang rough-in box in opening. Put drip trays, terminal box at cabinet front.



HOW Workman is installing Norris-Thermador "WO-18A" oven. Oven has $23\frac{1}{2}$ " width (front frame), $28\frac{11}{16}$ " distance between floor and bottom of oven.



HOW The electrical supply for Norris-Thermador oven unit should be 3 wire, 120/240-volt A. C. single-phase current with a grounded neutral. Unit being installed is mounted on stack on cabinet unit.

For better kitchens,
for better remodeling jobs,
it's the extras that count . . .
use the latest equipment.

kitchen sales extras

▼ CABINETS AND COUNTERTOPS FOR MODERN WORK EASE

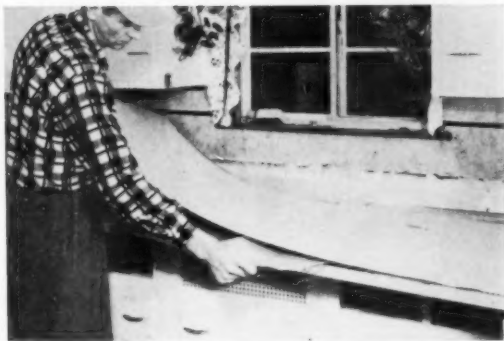

WHAT Formica is being applied to a countertop in the kitchen. **Check reply card No. 7073, on p. 148.**

HOW Spread Formica Type AA cement. When dry, (test with brown paper) pressure with roller.



WHAT Installation of Lyon steel kitchen cabinets is shown above. **Check reply card No. 7074.**

HOW Wall cabinets and base cabinets should be placed with the corner working to open ends.



WHAT Custom-cabinet look results from use of Bilt-Well units by Carr, Adams & Collier. **Check No. 7075.**

HOW When lower cabinets are in place, apply counter top, hardware, brace upper cabinets and attach.



WHAT Consoweld plastic surfacing is applied on walls and countertops in this kitchen. **Check No. 7076.**

HOW Consoweld 10 (1/16" thick) has been applied to walls. Linen finish is applied to counter area.

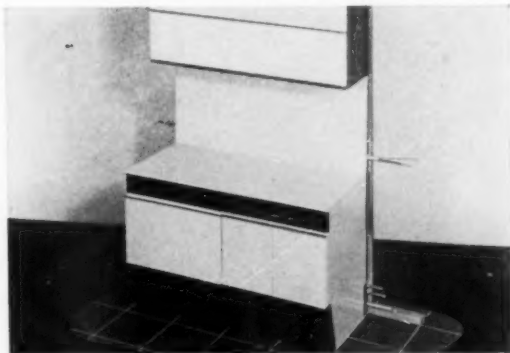

WHAT Frigidaire Holiday kitchen shown above is a free-standing unit, 4' wide. **Check No. 7077, p. 148.**

HOW Rear view shows electric wiring behind back-panel, water pipes and drain near floor level.

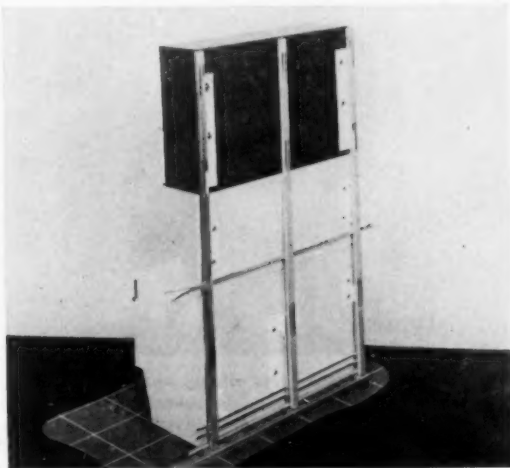

How to extend

▼ ADD A TERRACE TO EXTEND AREA



WHAT This patio forms an extension of the living room. Easy to build, addition of terrace or porch updates a house, gives it greater sales value. (Wire Reinforcement Institute) No. 7078, p. 148.



HOW 1 Workmen place and overlap welded-wire fabric for diagonally inset barbecue foundation slab. Concrete here will be 6" thick. Patio thickness elsewhere will be 4" thick.



HOW 2 Concrete worker uses shovel to spread concrete. Welded wire fabric has been lifted by worker to mid-thickness of slab, where it is most effective in controlling and minimizing cracking.



HOW 3 "Jigger" is used to vibrate or tamp the plastic mix. Tamping embeds welded wire fabric in concrete for more effective crack control, brings fine material to surface for smooth finish.

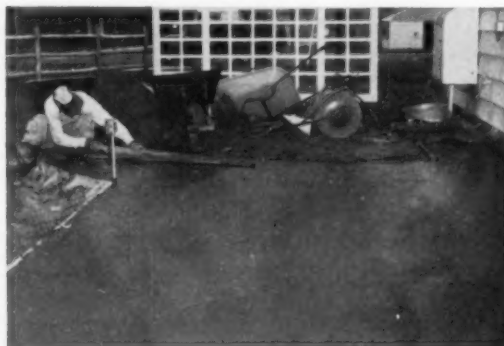

HOW 4 Wood floating of patio and barbecue slab is done by finisher. Steel troweling which creates the smooth final finish, is not done until several hours after the initial placement of concrete.

living space outdoors

▼ ROOF THE TERRACE FOR INDOOR-OUTDOOR PROTECTION



WHAT Twelve 40½-inch x 12-foot panels of corrugated Alsynite will create covered patio. Here, worker secures panels to rafters and purlins, sealing side laps with Alsynite clear mastic.



HOW Finished patio. Alsynite panels used here feature Filtron 25 which blocks solar heat, provides non-glare soft illumination. Alsynite Company of America. Check No. 7079, p. 148.



WHAT Lightweight cover is provided for this terrace with canvas. National Cotton Council. No. 7080.

HOW The family living in this home plans to stay on friendly terms with the sun all summer. Cotton canvas provides ample shade. Burnt orange roof not only protects patio, but keeps house cool.



WHAT Plastic panels of different colors are used to cover this patio. (Filon Plastics) No. 7081.

HOW Paint framework before installing Filon plastic panels. Pre-drill holes in panels to eliminate possibility of crazing marks. Low and medium light transmitting colors conduct less heat.

How to

▼ FENCE IT, RAIL IT, OR SCREEN IT

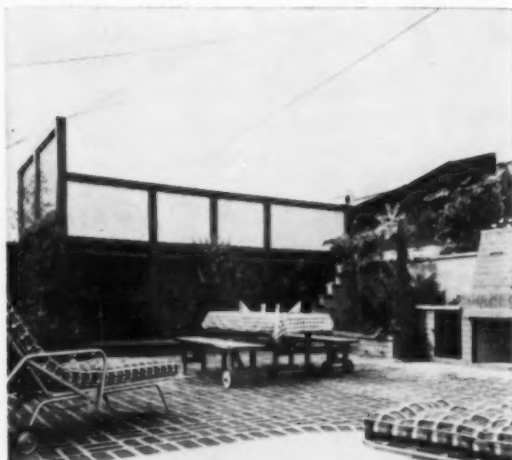

WHAT Redwood and plastic panels combine to fence off outdoor living room. (Filon) **Check No. 7082.**

HOW Corrugated plastic panels form top portion of fencing, create privacy ring around outdoor living room, act as a windbreak. Installation of corrugated material uses corrugated wood stops.



WHAT Ornamental iron railings added to a porch help to dress it up. (R. G. Coffman Co.) **No. 7083.**

HOW Railings like these are easy to install, take up only a 1-inch strip of floor space. Railings shown above are of ornamental iron, but ornamental aluminum railings are available too.

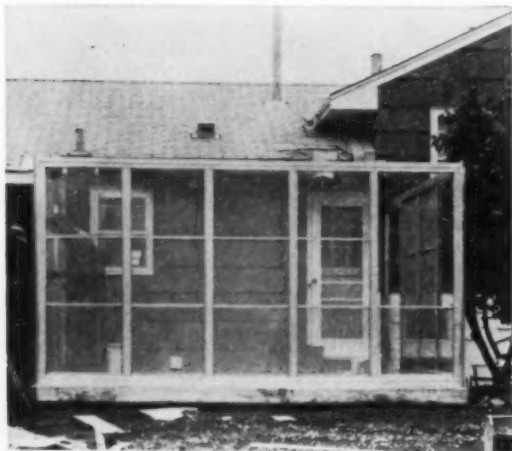

WHAT Adding a porch increases the value of any home. Porch is all-aluminum (Storm Sash) **No. 7084.**

HOW Adding a porch enclosure, like this one, is like building another room on to the house. When it is built of aluminum posts and aluminum screening, it becomes a rustproof, lifetime job.



WHAT This porch enclosure uses screening on ceiling as well as walls (Kaiser Aluminum) **No. 7085.**

HOW The shade screening used to enclose this outdoor living room is made of thousands of very tiny louvers, set at a slight outward angle to block sunrays. Terrace framing is of redwood 2x4s.

update around the house

▼ ADD A PACKAGED BASEMENT ENTRY

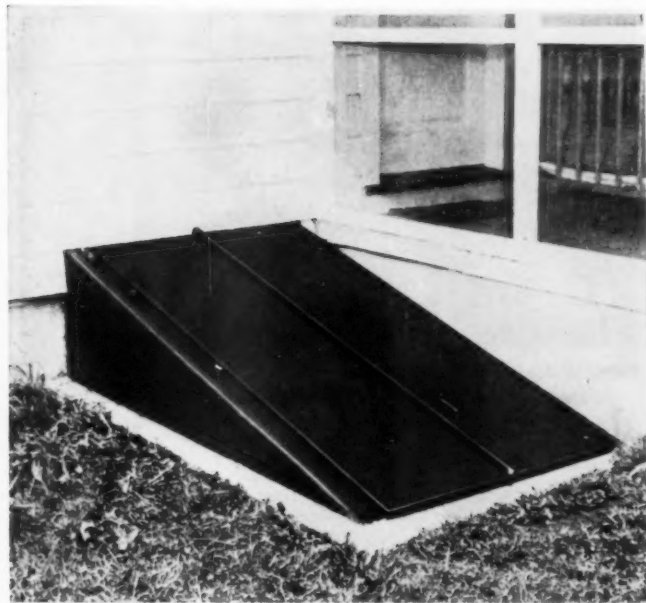

WHAT A wornout wood hatchway can be replaced with an all-steel basement door such as the one shown in the photograph above. The door is manufactured by The Bilco Co. Check No. 7086, p. 148.

Outdoor basement entries often need replacement, and here's an idea for you

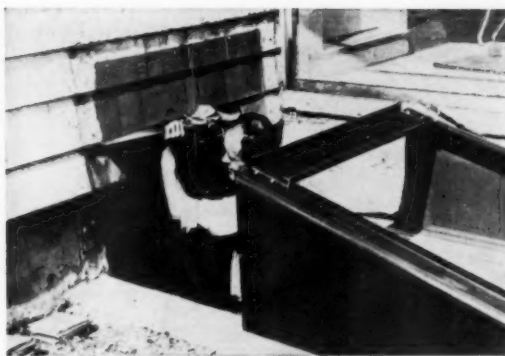

HOW Cut out shingles or clapboards. Fit Bilco tightly against foundation by marking around back of frame. Cut out shingles or clapboards to assure snug fit. (Not necessary on masonry houses.)

JULY 1956

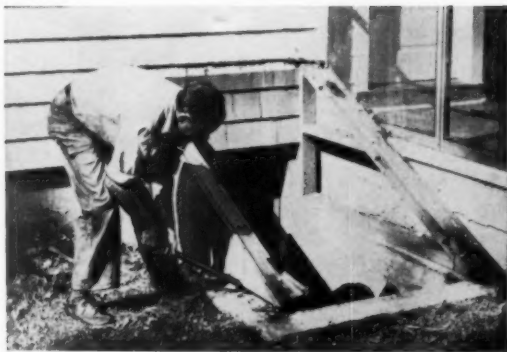

HOW Remove the wood door. Removing your wood hatchway is the next thing to having it fall off by itself. In about 15 minutes, you should have the old wood basement door out of the way.



HOW Assemble the frame. Break the steel strapping on the Bilco package. Assemble frame in accordance with instruction sheet. It takes only a couple of minutes to tighten 8 nuts and bolts.



HOW Attach doors to frame. Put doors on frame by inserting one pin in each hinge. Check door alignment. Remove frame, drill holes into masonry, replace frame, fasten to concrete and caulk.

MORE OUTDOOR REMODELING IDEAS ON P. 165 ▶

How to add

▼ ATTIC FAN INSTALLATION VENTILATES ENTIRE HOUSE



WHAT Installation of a Lau panel fan in the gable end of a truss roof. Opening in two-story brick and frame house readied for unit. Made by Lau Blower Co. No. 7087 on page 148.



HOW 1 After cutting ceiling opening near end of upper hall, ceiling louvre is fitted in with care to prevent binding of fan blades. Two-speed operating switch will be placed below louvre.



HOW 2 Automatic exhaust louvre is placed at end of gabled roof. Original vent is covered. On outside, louvre is finished with water table or flashing for weather resistance.



HOW 3 Rough flooring, adequate to support the fan, is layed at the end of the roof gable. Flooring will also insure holding of fan snugly against the exhaust louvre.

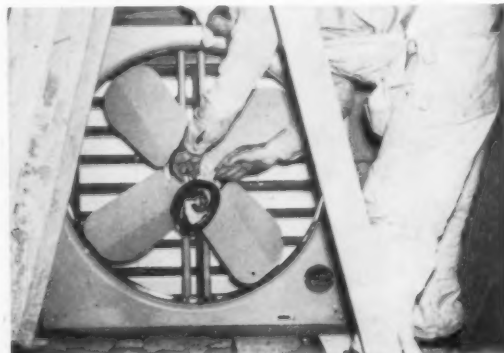

HOW 4 Securely placed and fitted, parts package of fan is removed, then entire unit checked for free movement of parts. Control switch near stairs in upper hall also checked as job is completed.

important extras

▼ DOORS ADD NEW OPERATING EASE, NEW LIFE TO GARAGE



BEFORE Typical garage ready for remodeling. Note that double doors, unhandy to open, are beginning to sag, probably cannot be safely locked.



AFTER New look, new ease in access, new safety with installation of a Roway overhead type garage door. By Rowe Manufacturing Co. No. 7088.



WHAT An Overhead door adds beauty and practical use. (Overhead Door Corp.) Circle No. 7089.

HOW Hanging an overhead door requires no extensive pre-installation work. Doors are built to size.



WHAT Barcol OVERdoor features eight window panels for light. Barber-Colman Co. No. 7090.

HOW Barcol's doors, all upward-acting, come in window-paneled, plain and ornamented models.

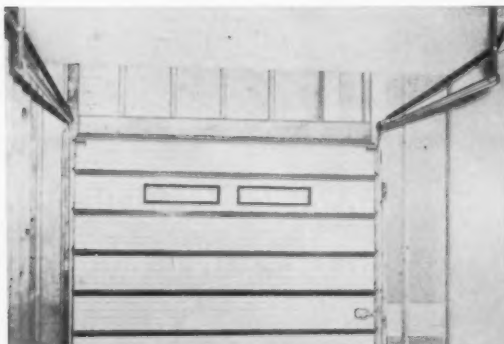

WHAT Won-Dor fits garage doors with a seven-panel model. By Windsor Door Co. No. 7091, page 148.

HOW Interior view shows 7-section, upward acting door which operates with ease on 16 rollers.

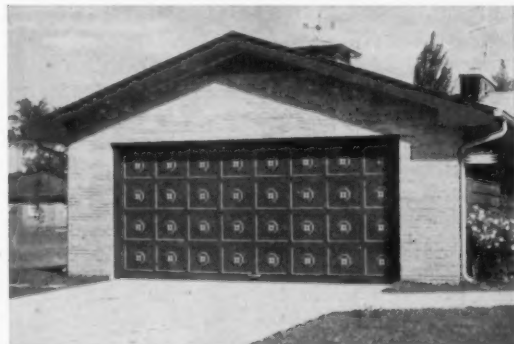

WHAT Sectional-type garage doors in variety of models. Frantz Manufacturing Co. No. 7092, page 148.

HOW Doors come in both single and two-car sizes, are upward-acting, have many decorator designs.



These men hammered out one of the strongest houses on record. They also used some of the newest construction techniques yet devised to show you...

How to build a better small house for less money

Here's why American Builder presents a "trade secrets" type house—complete with plans, specifications, details and a resume of techniques: (1) it offers a virtual mine of information on how to construct a better house for less money; (2) it bears a marked resemblance to many one-story frame houses going up right now all over the country, yet it differs from them in its much-needed emphasis on good nailing practice; (3) it is soundly, though not always conventionally, engineered. From it you can learn better wood-floor-over-slab construction, better attic ventilating methods, quicker ways of laying out and tilting up walls. And it shows you how to save space with thin-wall partitions.

Co-sponsored by the research staff of NAHB, Living for Young Homemakers, and the Independent Nail and Packing Co., the house was built for George Stern, Virginia Polytechnic Institute, Blacksburg, Va. Into it went years of engineering research on nails and trussed rafters by Stern, some of NAHB's own best research efforts and a number of Living's smartest decorating and furnishing ideas.

The house was built by A. E. Price of Blacksburg.

It was his first venture with a "trade-secrets" type of house. After a study of the blueprint on the right, it can be your first time too.

Actual cost of building this house will vary, of course: Stern figures it can be done for \$14,500, exclusive of land, appliances and other extras.

AMERICAN BUILDER
BLUEPRINT HOUSE

232

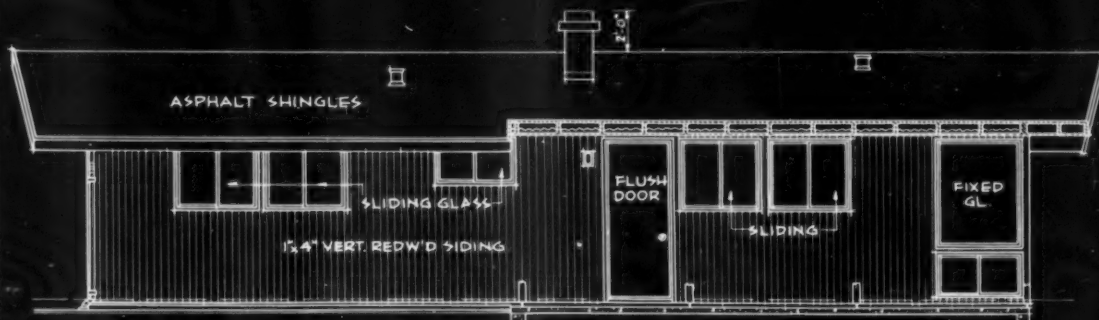

FRONT ELEVATION
SCALE 1/8" = 1'-0"

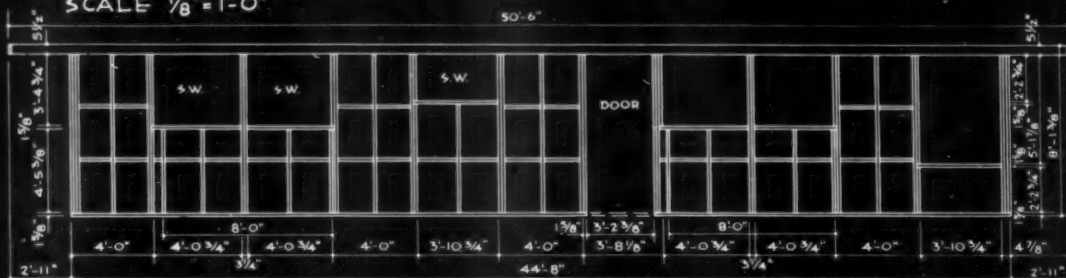

FRONT WALL FRAME
SCALE 1/8" = 1'-0"

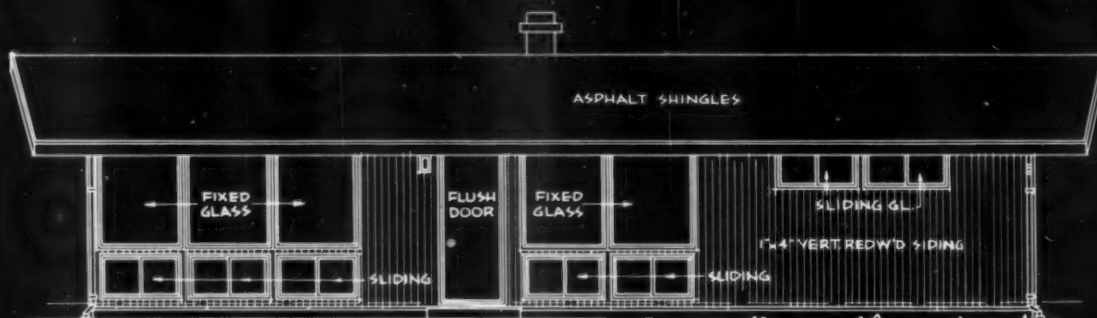

REAR ELEVATION
SCALE 1/8" = 1'-0"

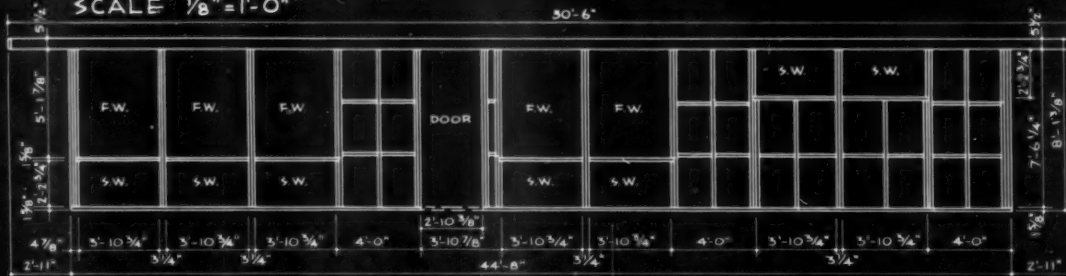

REAR WALL FRAME
SCALE 1/8" = 1'-0"

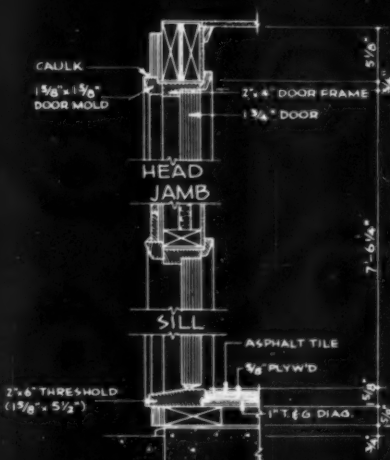
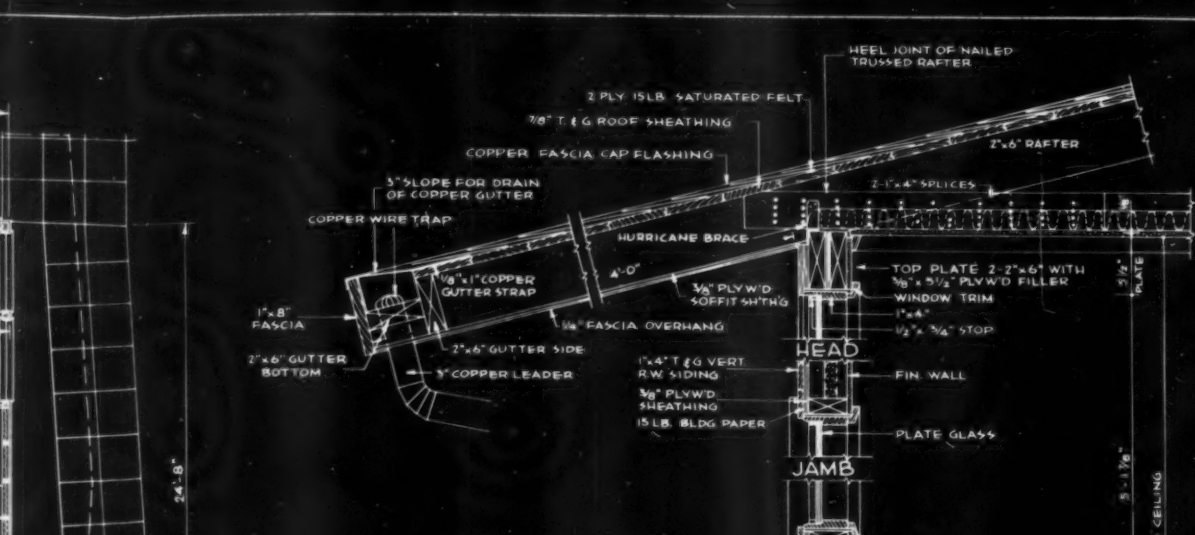

SECTION THROUGH ENTRANCE DOOR
SCALE 3/4" = 1'-0"

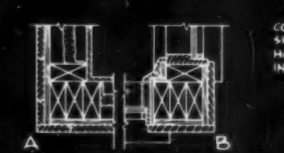

SECTIONS THROUGH CORNERS OF HOUSE
SCALE 3/4" = 1'-0"



SECTION THROUGH WINDOW WALL AND FOOTING
SCALE 3/4" = 1'-0"

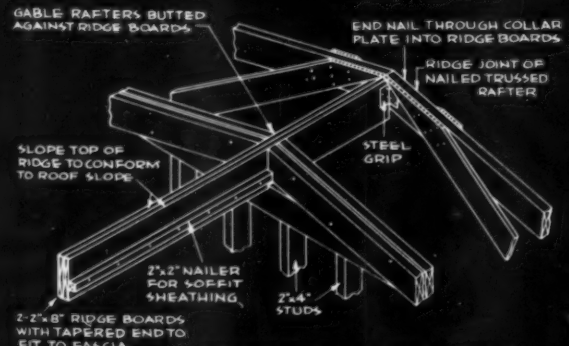

RIDGE OUTRIGGER

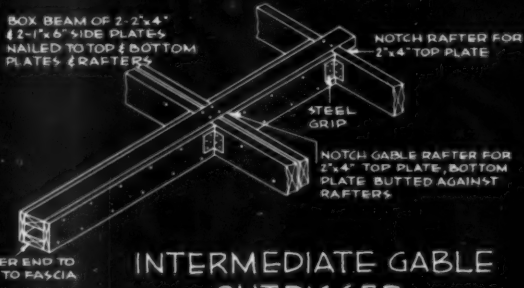

INTERMEDIATE GABLE OUTRIGGER

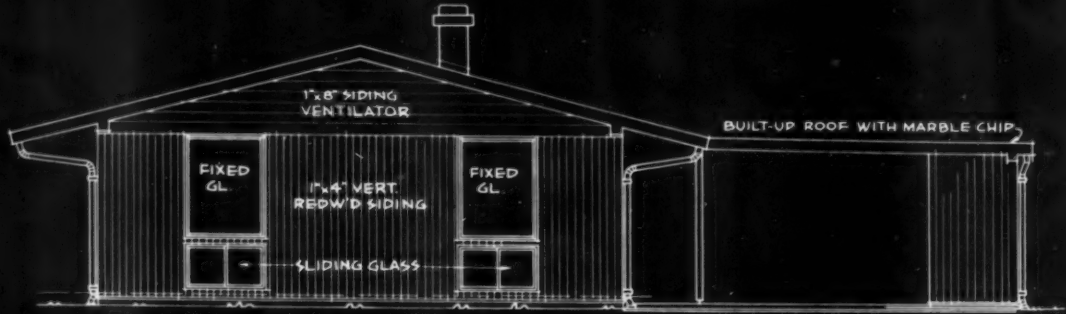

LEFT SIDE ELEVATION
SCALE $\frac{1}{8}'' = 1'-0''$

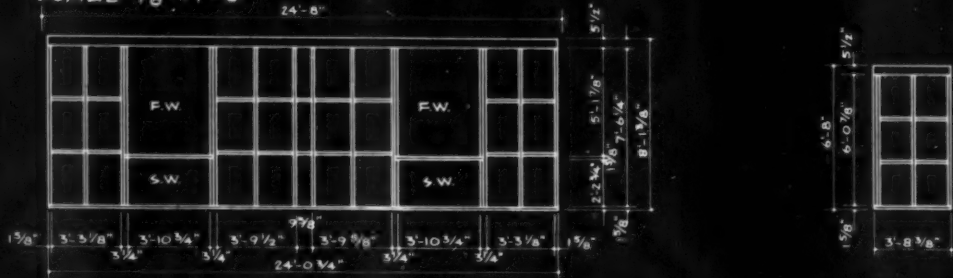

LEFT SIDE WALL FRAME
SCALE $\frac{1}{8}'' = 1'-0''$

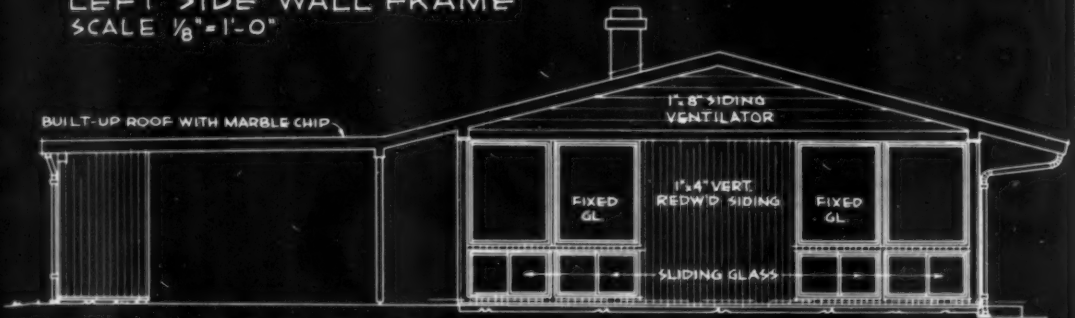

RIGHT SIDE ELEVATION
SCALE $\frac{1}{8}'' = 1'-0''$

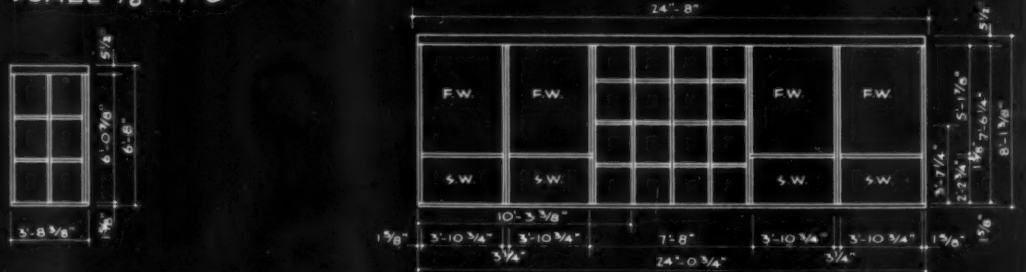

RIGHT SIDE WALL FRAME
SCALE $\frac{1}{8}'' = 1'-0''$



STORAGE - FRONT ELEVATION
SCALE $\frac{1}{8}'' = 1'-0''$



GABLE-END VIEW of house from garden. Note all-over ventilation of gable, deep overhangs above bedroom windows.

To right of patio and attached to carport is huge storage wall—596 cubic feet of space for tools and equipment.

BETTER SMALL HOUSE FOR LESS MONEY *continued*

How to keep 1100 square feet cool in summer, warm in winter

Wide overhangs and white asphalt shingle roof give year-around protection and make this an especially pleasant house in the summer. Each gable is a giant-sized louver (siding boards are blocked up on their lower edges) for good cross-ventilation. The attic, while small, is nevertheless an ideal place for installing an air-conditioning system.

Like most tight houses of today this one loses very little heat because of the insulation built into its slab, ceiling and sidewalls. And moisture is stopped before it gets into the house from below or above ground.

A marvel of compactness, the 1100 square-foot plan features partitions pared down to a thickness of two inches. That means they take up only two-thirds of the space occupied by conventional interior walls. Thin-wall partitions don't require any change in stud-spacing (24 inches); they merely use studs turned flatwise. Any utilities leading into them—wires, pipes, etc.—must of necessity be small in diameter. But with careful planning and the use of copper piping this trouble can be largely avoided.

Whether you enter this house from the *(Continued)*

BETTER SMALL HOUSE FOR LESS MONEY *continued*

front or rear, you are inevitably drawn to the colorful kitchen shown below. Through good planning, it actually looks like a country-size kitchen, even though it does not have half the space of one.

No attempt was made to force this kitchen into an open plan in conjunction with the living-dining area. Instead, it was provided with wood folding doors at both entrances to close it off when needed. Similarly, no attempt was made to install a planter or room divider in the living room to separate it from the front entrance area.

The choice of a combined range and oven makes a good deal of sense in a kitchen of this size. Also sensible is to make the freezer do double duty as a room divider. The kitchen is attractively and efficiently lighted, and it has a wealth of work space, with surfaces quite easy to clean.

Time-study statistics tell story

Stern studied this house from beginning to end. Here's his break-down of the hours needed to lay out, assemble and erect the four exterior walls, exclusive of gables:

- 7½ hours for jig layout and blocking for assembly of continuous top plates,
- 6 hours for plate assembly,
- 109 hours for framing and assembly of all four exterior walls, exclusive of plates and sheathing.
- 184 hours for installation of windows and doors, building paper and siding, casing and trim, and tilting up of walls,
- 17½ hours for transporting materials to the site, including loading and unloading.
- 10 hours lost due to bad weather.

Photos: LIVING For Young Homemakers





ALL-BLUE BATH off master bedroom has Panelite walls, flush-mounted cabinet with sliding mirrors, built-in lavatory. Shower fittings are made expressly for thin walls, plumbing fixtures are back-to-back with second bathroom.

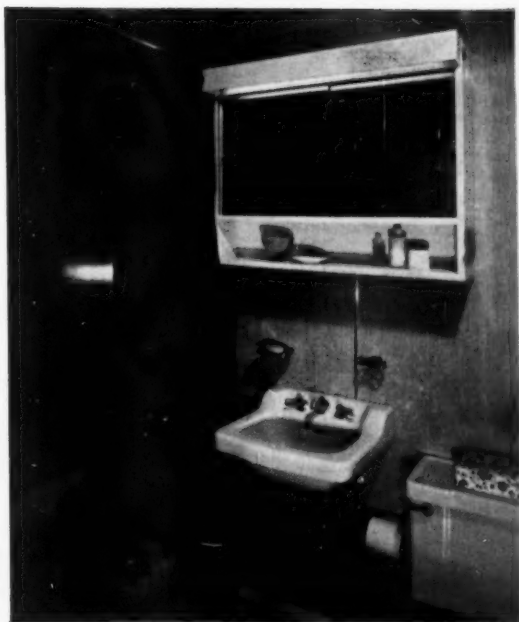

INSIDE BATH off hall is full size, has matching fixture and wall colors. Slightly smaller than master bath, it has ventilating fan in ceiling controlled by light switch. Another economy: cabinet and lavatory are not built-in.



SECOND BEDROOM, like master bedroom, has gypsum wall-board ceiling and walls. Perimeter heat diffuser is on floor under window, which is ventilated by sliding sash. Linen closet at end of hall easily services both bedrooms.



LIVING ROOM has floor-to-ceiling windows, oak flooring, attractive walnut plywood walls. One end of room may be turned into formal dining area. Front entrance is at left. Glass area could contain sliding doors to terrace.

◀ **FOUR-AREA KITCHEN** is masterpiece of planning. Taking almost one-sixth of house, it has space for food preparation, dining, laundry, menu-making. Countertops have fluorescent work lights, handy roll-top spice cabinets.

**FOR FIFTEEN TIPS ON BUILDING A
SMALL HOUSE FOR LESS, TURN PAGE ▶**

Match plastic counter to plastic floor—
to Sell More!

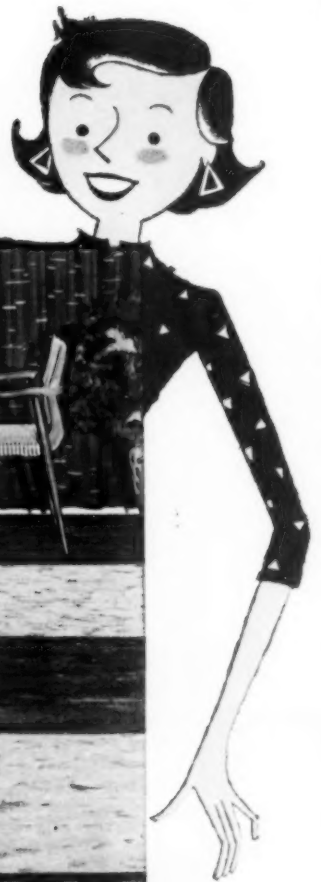

Gold Seal NAIRON* "CORRELATED COLORS" STANDARD

Sell the kitchen that sells the home!

Homemakers can't resist the beautiful harmony of NAIRON Standard plastic color-keyed floors and countertops. Especially when you point out the almost unlimited possibilities for custom design . . . the outstanding wear . . . the easy care!

Gold Seal NAIRON Standard for floors and walls, and Nairontop* for countertops make a time-saving, work-saving team! Their satin-smooth surfaces seal out dirt . . . make cleaning so easy. Grease, grime and spills wipe up with a damp cloth. Household acids and solvents won't harm them! Floors are quiet and comfortable, countertops muffle the clatter of kitchenware. Decoration goes through to the backing.

Color correlated Gold Seal NAIRON Standard Plastics have been seen by millions of readers of these outstanding magazines—"Better Homes and Gardens," "House Beauti-

ful," "Living For Young Homemakers," "Life," and "Look." Cash in on your share of these pre-sold customers!

SPECIFICATIONS

For Floors: Install Nairon Standard 6-ft. wide yard goods over suspended concrete and wood under-floors. Install Nairon Standard 9" x 9" tile goods over on-grade concrete or over suspended concrete or wood under-floors.

For Walls: Install Nairon Standard yard goods and tile over smooth walls.

For Countertops: Install Nairontop over smooth surface working areas. Nairon Standard is available in 20 marbled tile and yard goods, 11 "Bermuda Hues" tile, and Nairontop 30", 36", 42" widths in 7" Marble" and 8 "Bermuda Hues."

SEE YOUR GOLD SEAL DEALER TODAY!

FOR HOME OR BUSINESS:
INLAID BY THE YARD—Linoleum • Nairon® Standard • Nairontop®
RESILIENT TILES—Rubber • Cork • Nairon Custom • Nairon Standard
Vinylbest • Linoleum • Ranchtile® Linoleum • Asphalt
PRINTED FLOOR AND WALL COVERINGS—Congoleum® and Congowall®
RUGS AND BROADLOOM—Loomweave®

© 1956 CONGOLEUM-NAIRON INC., KEARNY, N. J.



FOR THE LOOK THAT'S YEARS AHEAD

Gold Seal®
FLOORS AND WALLS

*Trademark

WITH GABLE OUTRIGGERS ON you can start sheathing. Windows are paneled against weather.



HOW TO BUILD A BETTER SMALL HOUSE FOR LESS *continued*

Use these 15 cost-saving construction techniques

The use of site-assembled tilt-up walls enabled builder Price to erect the basic structure and get it under roof within a single working day. But he soon learned that tilt-up walls can be troublesome.

- 1 KEEP TILT-UP WALLS** as lightweight as possible; otherwise you may have trouble lifting them. The 44-foot walls proved too unwieldy for Price's ten-man crew to handle. Better to tilt up by sections.
- 2 DUCTS PROTRUDING** from the sub-flooring can be a pain when assembling walls. Even perimeter ducts get in the way. Since sub-floor won't be large enough for all four wall assemblies, you may have to stack them.
- 3 PRE-SIDING PRESENTS PROBLEMS** too. You have to protect it prior to tilting up walls. That means protection from careless workmen as well as weather. Worst of all, it means adding too much weight to walls.
- 4 TOP AND BOTTOM PLATES** should be continuous in tilt-up assembly; make cut-outs for openings later. Use 2" x 6" lumber on edge, with $\frac{3}{8}$ " plywood filler in between. Let top plates cantilever to support roof overhang.
- 5 BY USING 2-FOOT STUD SPACING** you will save 104 board feet of 2" x 4" lumber, or almost 10 per cent of the lumber required for exterior wall framing. Use of threaded nails allows thinner ($\frac{3}{8}$ ") sheathing.



- 6 AIR DUCTS SLOPING** from the furnace plenum to the outside wall call for more concrete than you think. Because of the increased thickness at the plenum, figure on 19 $\frac{1}{4}$ cu. yds. of concrete, as opposed to 12 $\frac{1}{2}$ cu. yds.



- 7 TWENTY-ONE TRUSSED RAFTERS** are all you need to build this house. Jig-assembled, they can be carried and tilted up by a few men. Use standard lumber; if it's too dense you're likely to split the splice plates.

MORE SMALL HOUSE TIPS AHEAD ▶

...here are 8 more
cost-cutting ideas

- 8** **3/8" PLYWOOD ROOF SHEATHING** on 24" rafter spacing needs extra support where edges are butted together. For this you'll need headers. Otherwise workmen may split it while walking on the roof.

- 9** **TEMPLATE FOR LOCATING PLUMBING** is necessary where tight planning calls for exact location of utilities. Plumbing template eliminates fumbling for location of pipes prior to pouring concrete.

- 10** **TEMPLATE FOR LOCATING NAILS** in trussed rafter members is also a must. Make templates out of sheet metal, use red shellac in spray gun to mark nail holes. Another tip: use a 3-lb. hammer to drive nail in one blow.

- 11** **JIGS FOR ASSEMBLING WALL FRAMES** may seem to be time-saving, but they may be time-consuming. Before you build that jig don't overlook the crayon. With it you can easily lay out assemblies on sub-floor.

- 12** **THIN-WALL PARTITIONS** are not only economical with space (they take up one-third that of conventional ones) but are easily capable of supporting kitchen cabinets—provided they are sheathed with 3/8" plywood.

- 13** **PRE-CUT STORAGE WALLS** are fine—if you don't have to pay the high cost of long-distance hauling. With Stern this amounted to one-fifth their basic cost. Reason: they had to be trucked in 240 miles.

- 14** **CONCRETE NAILS** can be driven directly into concrete (see nailing schedule, right) if not too close to edge. Otherwise use 1/4" diam. star drill first and fill holes with hot lead to prevent splitting of slab.

- 15** **IF YOU REALLY WANT** to anchor your trussed rafters to top plates, use hurricane braces in combination with threaded nails. This applies especially to anybody living in an area where high winds are prevalent.

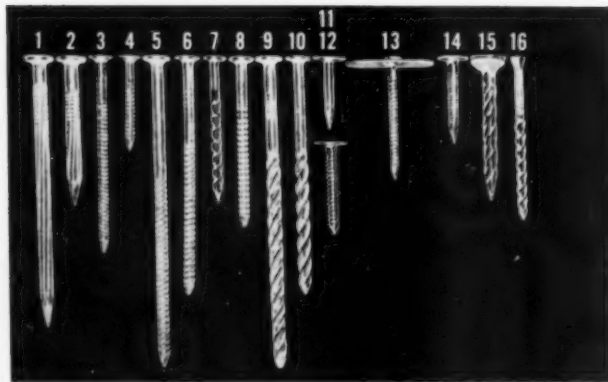

HELICALLY THREADED, annular threaded, fluted . . .

Use these 35 nails for

TYPE OF NAIL

1	MASONRY: 2 3/4" x .148" hardened steel fluted Screwite
2	MASONRY: 1 1/2" x .148" hardened steel fluted Screwite
3	UNDERLAYMENT: 2 1/8" x .115" bright steel Stronghold
4	UNDERLAYMENT: 1" x .098" bright steel Stronghold
5	FRAMING: 3 1/4" x .135" hardened steel Stronghold
6	FRAMING: 2 1/2" x .120" hardened steel Stronghold screw
7	FRAMING: 1 1/2" x .105" bright steel Screwite
8	SHEATHING: 1 3/4" x .120" bright steel Stronghold
9	FRAMING: 3 1/4" x .135" hardened steel Screwite
10	FRAMING: 2 1/2" x .120" hardened steel Screwite
11	SHEATHING PAPER: 7/8" x .105" bright steel common
12	ROOFING: 1" x .120" bright aluminum Stronghold
13	ROOFING: 7/8" x .120" galvanized steel Stronghold
14	ROOFING: 1" x .120" bright alum. Stronghold Squarehead
15	SHEET METAL: 1 1/2" x .145" bright aluminum Screwite
16	SIDING: 1 3/4" x .105" bright silicon-bronze Screwite
17	CASING: 2 1/8" x .115" bright silicon-bronze Screwite
18	CASING: 3" x .165" bright silicon-bronze Screwite
19	SHEET METAL: 1 1/8" x .110" bright copper Stronghold screw
20	SHEET METAL: 1 1/2" x .120" bright copper Stronghold
21	SHEET METAL: 2 1/2" x .135" bright copper Stronghold
22	CASING: 2 1/2" x .105" bright steel Stronghold
23	INSULATION: 1 1/2" x .105" bright steel Kurlicue
24, 25, 26	GYPSTUM BOARD: 1 3/8" x .101" steel Stronghold
27	FLOORING: 2 1/4" x .115" hardened steel Screwite
28	CASING: 1" x .072" bright aluminum Stronghold
29	SIDING-TRIM: 1 1/2" x .072" bright monel Anchorfast
30	CASING: 1 3/4" x .083" bright steel Screwite
31	CASING: 1 1/2" x .083" bright steel Screwite
32	CASING: 1" x .072" bright steel Screwite
33	CASING: 1" x .072" bright aluminum Screwite
34	CASING: 1" x .065" bright stainless steel Screwite
35	CASING: 1" x .054" enamelled steel Kolorpins

SAY YOU CAN BUILD A BETTER SMALL HOUSE FOR LESS MONEY

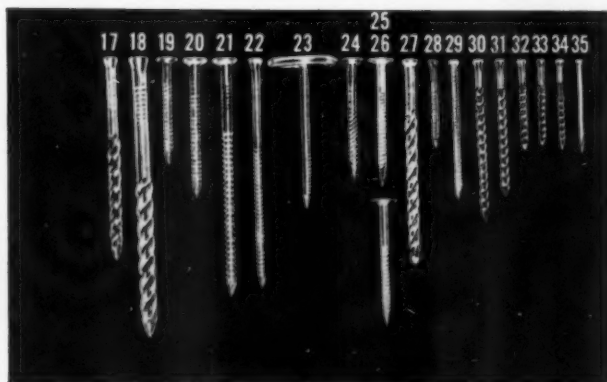

AND A FEW PLAIN SHANK or common nails . . .

stronger joint-fastening

WHAT/HOW

- Sills and sleepers to slab, nailed 1 1/2' o.c., seven days after pouring
- Insulation to edge of slab, 4-6 per panel; carport door tracks to slab
- 3/8" sub-floor to sleepers, face-nailed 6" o.c. outside, 12" o.c. inside
- 3/8" to 5/8" sub-floor, face-nailed 6" o.c. outside, 12" o.c. inside
- 2" x 4" soleplates to sub-floor and sills, face-nailed 1' o.c. staggered
- 2" x 4" studs to plates, cripples to studs; partition top plates to truss
- Hurricane braces to top plates, 8-9 per brake; outriggers to truss
- 3/8" wall sheathing to stud; 3/8" roof sheathing to rafters, 6" o.c. outside
- Trussed rafter members, 138 nails per truss, spaced by template
- Trussed rafter joints, 38 per truss, face-nailed as per detail
- Building paper to sheathing, face-nailed 12" o.c.
- Asphalt shingles to sheathing, face-nailed 3 per shingle
- Built-up roof to sheathing, face-nailed 10" o.c. per row
- Gable screen to stud and plate, face-nailed 1' o.c.
- Chimney frame and vent cap to sheathing and framing, as provided
- 1" x 4" vertical siding to sheathing, face-nailed 5 per each full length
- 1" x 4" casing to top plate and stud, face-nailed 1' o.c. staggered
- 2" x 6" window sill to sill, face-nailed 1' o.c. below glass
- Flashing to sheathing, face-nailed 4"-6" o.c.
- Gutter strap to sheathing, face-nailed 4"-6" o.c.; pipe strap to framing
- Downspout hanger to sheathing and framing, face-nailed 5' o.c.
- Casing molding to casing and interior panels, face-nailed 1' o.c.
- 1" batt insulation to stud, 2" batt to lower chord, face-nailed 1' o.c.
- 1/2" gypsum board to lower chord or stud, face-nailed 6" o.c.
- Flooring to sub-floor and sleepers, toe-nailed 1 1/2" o.c. at 40° angle
- Plate glass molding to casing, face-nailed 8" o.c.
- 1" x 4" siding to casing, face-nailed 8" o.c.
- Base mold to flooring and soleplate, face-nailed 2' o.c.
- Storage wall units (Novoply to Novoply), face-nailed 6" o.c.
- Storage wall units (plywood to Novoply), face-nailed 6" o.c.
- Panelyte molding to framing, face-nailed 8"-12" o.c.
- Panelyte molding to sheathing, face-nailed 8"-12" o.c.
- 1/4" walnut plywood to studs, 6" o.c. outside wall, 12" o.c. inside wall

Use this estimating guide and product list

House	Frame	Ranch
Area		1102 sq. ft.
Volume		8816 cu. ft.

CONCRETE WORK

Location	Actual*	
Foundation		
Footing (3'0")	275 cu. ft.	
House Slab 4"	368 cu. ft.	
Car Port Slab 4"	124 cu. ft.	
Storage Slab 6"	50 cu. ft.	
Shower Slab 6"	12 cu. ft.	
	829 cu. ft. or 871 cu. ft. or 33 cu. yds.	

*Add 5% for waste

PLASTER

Location	Description	Amount
Walls	1/2" Drywall	Approx. 800 sq. ft.
Ceilings	1/2" Drywall	Approx. 1102 sq. ft.

FRAMING LUMBER

Location	Size	Pieces	B.F.M.
Mud Sill	2 x 6	—	190
Sleepers	2 x 3	—	300
Sole Plate	2 x 4	—	127
Top Plate (2)	2 x 6	—	380
Studs	2 x 4	300/8	1600
Plates (3)	2 x 4	—	260
Rafters	2 x 6	42/18	756
Bottom Chords	2 x 4	42/14	392
Purlins	1 x 6	—	360
Box Beam (2)	2 x 4	—	60
Box Beam (2)	2 x 6	—	90
Ridge Outrigger (2)	2 x 6	—	90
Ribbon or Nailor	2 x 2	—	15
Carport Joists	2 x 8	13/16	278
Bridging	1 x 3	—	13
Storage Headers (2)	2 x 6	—	120
Storage Plate	2 x 4	—	40
Storage Studs	2 x 4	30/8	160
Gutter Strip	2 x 6	—	90
Ridge Fillers	2 x 8	—	62
Gable Nailers	2 x 2	—	50

SHEATHING AND MISCELLANEOUS

Location	Description	Actual*
Kitchen Linoleum	Linoleum	175 sq. ft.
Flooring	Pre-finished 1 x 4 T & G	1100 sq. ft.
Side Wall Sheathing	3/8 Plywood Sheath	916 sq. ft.
Gable Siding	1 x 6 Bevel Siding	96 sq. ft.
Roof Sheathing	1 x 6 T & G	1440 sq. ft.
Roofing	210# Asphalt	1440 sq. ft.
Carport Roof Sheathing	1 x 6 T & G	400 sq. ft.
Carport Roofing	Marble Chip	400 sq. ft.
Insulation Ceiling	2" Batts	1100 sq. ft.
Insulation Walls	2" Batts	816 sq. ft.
Gutters	Metal	115 Lin. ft.
Leaders	Metal	60 Lin. ft.
Siding	1 x 4 red wood	916 sq. ft.
Kitchen Plywood	Waterproofed plywood	175 sq. ft.

*Add 10% for waste.

MILLWORK

Ext. Trim	Location	Description	Amount
Fascia		1 x 8	211 Lin. ft.
Soffit		3/8" waterproofed plywood	360 sq. ft.

ESTIMATING GUIDE AND PRODUCTS
LIST CONTINUES ON PAGE 238 ▶



▲ **FRIENDLY COMPETITORS** in Austin, Texas spent six months in search of suitable land for home sites. By combining efforts, they located and developed the site shown above—big enough to keep them supplied for the next five years.

▶ **BARTON HILLS**, the choice 535-acre tract eight Austin builders located after long search. They put in their own improvements, opened tract with 1955 Parade of Homes. To date they have sold over 100 lots, built 70 houses.



Here's how

There were no good lots left in Austin, Texas. But eight "friendly competitors" put up \$4500 each to hunt with . . . and ended up with a \$53 million project.

The squeeze was finally on. No more good home sites for small builders were available in Austin, Tex., at a decent price.

What was more, the cost of subdividing had suddenly skyrocketed, due to a 1953 ordinance requiring heavy duty streets, curbs, gutters and facilities.

But eight tough-minded builders faced the hard facts and came up with a solution that sounds like a Horatio Alger success story. They now have control of ample land for a five year program. It's a story that will inspire small builders with similar land problems everywhere.

The eight builders had gotten on friendly terms through local Build-

er's Association meetings, through the Parade of Homes, and through participation in Austin's Air-Conditioned Research Village. They formed Builder's Development Corporation, headed by S. R. Sheppard, putting up \$4500 each. For six months they combed the area for a small site they could buy—looking for about 20 acres. But without luck.

Then came the big break: a choice 535 acre site that had never before been available. It took hard selling, long negotiating, and intricate financing arrangements. But they swung the deal. Two banks helped buy the land and finance the improvements with repayments guaranteed out of lot sales. Addi-

tional funds were raised from suppliers.

In record time they put in 22 blocks of streets with 122 lots and opened the project with Austin's 1955 Parade of Homes. In the first eight weeks 25 houses priced at \$17,000 to \$20,000 were sold. Barton Hills, the new project, was off to a solid start.

Before long the builders sold 31 acres to the city as a park for \$100,000. Other pieces went to schools, churches, and a large community center corporation. This left 1,250 lots—enough to keep Austin's small builders busy a long time.

The \$36,000 start has mushroomed into what is now described as a \$53 million project.

All of this is being done through hard work, many headaches, and good management. Here are six points the builders have found highly important to this kind of cooperative venture:

1. Incorporate a group of friendly, cooperative-minded builders with lots of "know how."

(Continued on p. 236)

teamwork solved the land crisis



... and here's how entire project will be air conditioned with units that fit in 33 x 42½ in. closet



FURNACE CLOSET holds 70½ in. high unit with cooling coil at top, air-intake return below. Waterless, air-cooled condensing units are outside.

Builders of Barton Hills have announced that all houses in the project will have year-round air conditioning. A blanket order for Typhoon Weather Selector units was placed for the remaining 1152 houses.

Simultaneously a new program was announced by Don V. Petrone, President of Typhoon, to help builders install and sell air conditioning. First step is the supplying of a cost-saver blueprint that accurately locates all sheet metal, gas, water, electrical and refrigerating connections. All this work is completed before the units arrive.

A five-point sales program is provided each builder which includes stick-on signs, thermostat plaque, newspaper ad mats, radio and TV announcements.

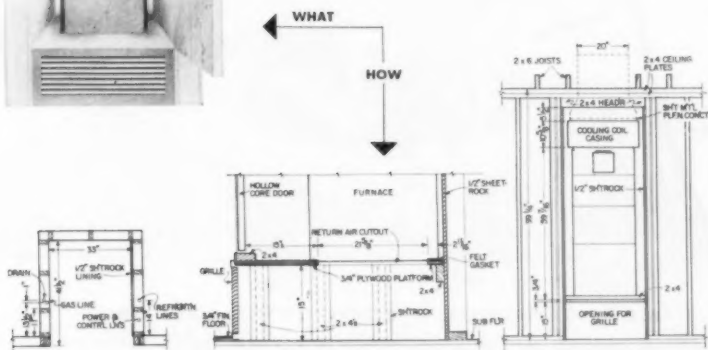

COST SAVER closet details like these are used by builders. They show exact dimensions which control placing of

sheet metal, gas, electrical, plumbing and refrigeration connections. All of these are installed in advance.

If you neglect fire-safe construction

will your homes be selling you?

Milcor Metal Lath and plaster provide 5-point protection

There are five vulnerable areas in your houses — places where fire is most likely to start and to be most destructive. When you apply Milcor Metal Lath and plaster at these danger points, you provide construction that is rated to withstand the passage of fire for one hour or more. Pound for pound, no other construction offers fire-ratings equal to metal lath and plaster.

Here are the five areas in which you should use Milcor Metal Lath and plaster for fire-safe construction:

- (1)..on wood-stud bearing partitions and walls, and as fire-stops between studs;
- (2)..in ceilings under inhabited floors, especially in areas over heating plants;
- (3)..at heating ducts and flues, and behind cooking equipment;
- (4)..under stairs and on stair walls;
- (5)..as base and reinforcement for exterior stucco.

The complete line of Milcor products also includes Corner Beads, Casing Beads, Studs and Channels, Screeds, Mouldings, Corner-Ex and Access Doors — all designed to help you build better homes.

Milcor Catalog No. 254 available upon request.

MILCOR[®]
Metal Lath

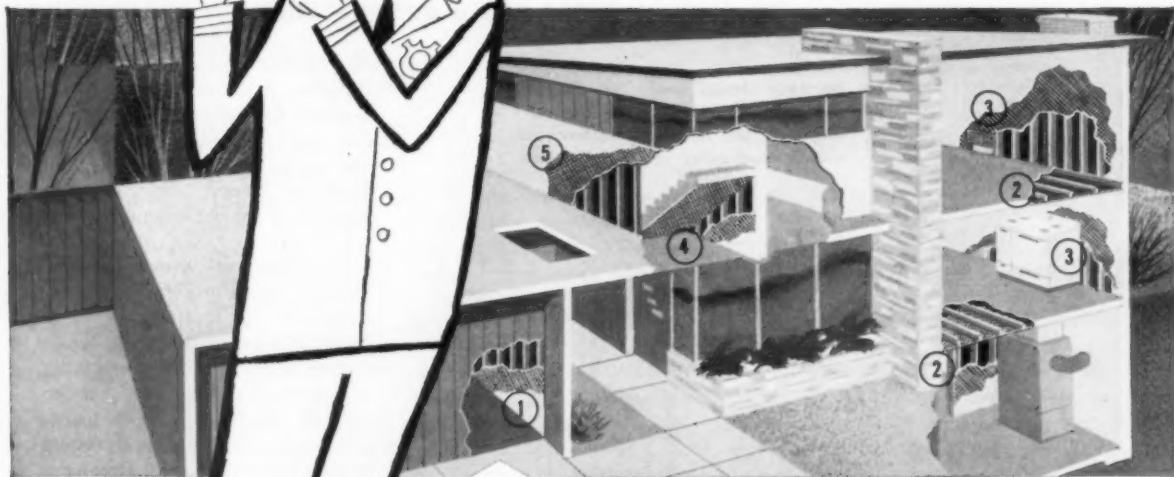

INLAND STEEL PRODUCTS COMPANY

DEPT. G, 4025 WEST BURNHAM STREET

MILWAUKEE 1, WISCONSIN

BALTIMORE • BUFFALO • CHICAGO • CINCINNATI • CLEVELAND • DALLAS • DETROIT
KANSAS CITY • LOS ANGELES • MILWAUKEE • MINNEAPOLIS • NEW YORK • ST. LOUIS

M-174A

The Payoff Departments

New Products and Catalogs.....page 149 →

Builders' Supermarket for new products and equipment, and for manufacturers' literature, on more remodeling ideas to go along with those on pages 73-103. Just detach the handy reply card at the beginning of the Supermarket and go right on through, circling the items that can mean money in your pocket.

Builder's Library 212 →

Here are books for better planning, buying, building, selling, ranging from landscaping to motel construction. American Builder reviews them, a handy coupon gets them for you.

How To Do It Better..... 218 →

From anchoring a foundation wall to keeping a fascia straight, these ideas for the man on the job have been pre-tested and found helpful by other builders.

Ask The Experts..... 222 →

Got a problem you can't solve? Our staff of experts analyzes reader queries, and may have some valuable tips for your operation. This month, the experts discuss the layout of a roller rink, de-icing of eaves, venting a kitchen fan, etc.

Keeping Up With The Law..... 226 →

American Builder's legal consultant, John F. McCarthy, offers valuable advice to builders on questions involving the law. This month, Mr. McCarthy points out the benefits of incorporating your business organization.

Technical Guide..... 232 →

Detailed drawings and complete instructions give you valuable information on remodeling with red cedar shingles.

Better Detail Plate..... 240 →

Another valuable remodeling feature: Explicit details of a shoe store that was remodeled by a Pasadena, Calif., builder. Save these pages; you'll be glad you did.

The Month Ahead..... 246 →

Things for alert builders to think about in the month of August.



Builders Know Famous Brands Make Quicker Sales

• New-home prospects have confidence in trusted brand-names like Orangeburg Root-Proof Pipe. Its reputation for high quality has helped many a builder "close the sale."

How Orangeburg Pipe saves trouble, cuts costs and builds profits for builders is a story of modern construction practice. It takes modern materials and time-cutting methods to reduce costs today. That's why home builders and general builders everywhere are turning to Orangeburg Root-Proof Pipe.

Orangeburg's long 8-foot lengths are easy to install—so strong and resilient that lines in service 50 years operate like

new. Famous Taperweld Joints seal root-proof with a few hammer taps—no cement, no compounds. Orangeburg is readily cut with a coarse tooth saw and, where necessary, quickly tapered on the job with a lightweight tapering tool.

Orangeburg Root-Proof Pipe is made in 2", 3", 4", 5" and 6" sizes. Use it for house-to-sewer and septic tank connections, downspout run-offs, storm drains and other outside non-pressure underground lines. Orangeburg also comes Perforated in 4" size for foundation drains, septic tank filter fields, draining wet spots everywhere. Look for the Orangeburg trademark. Be sure you get the genuine. For more facts write Dept. AB-76.

ORANGEBURG MANUFACTURING CO., INC.
Orangeburg, N. Y. West Coast Plant—Newark, Calif.



EASY TO HANDLE



EASY TO INSTALL



1/4 BEND



WYE



TEE



1/8 BEND

EXCLUSIVE FITTINGS

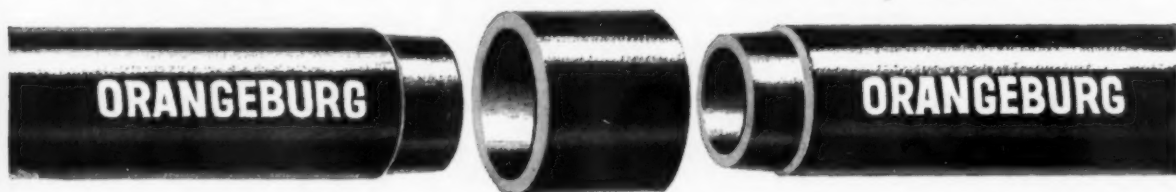

What to build

Here's a new way to custom-build with stock parts

The magazine building system is going to get off the ground because it has to do two things that have done so perfectly elsewhere: sell more than 100,000 copies a year and build. The reason for this is simple: in an area of large developments, to have complete or a million-and-one home with the big boys, had to be an area where custom building predominates. The key to success here is offering a variety of sizes and floor plans.

The house shown below is the first built from the system of the magazine system by Leitch, Inc., of Leitchville, Mass., and designed by a local home and American. This house offers 1000 square feet of living space plus a garage, and is expected to sell for around \$12,000 and up, including land and depositing an equivalent and down. It is probably the smallest practical house built by this system, getting both for a development build.

WOOD BRACKET 4 x 17 provides extra strength for the wide portion of the roof truss. Dimension: approximately 1/2 x 1/2 inch.

WOOD BRACKET 4 x 17 provides extra strength for the wide portion of the roof truss. Dimension: approximately 1/2 x 1/2 inch.

WOOD BRACKET 4 x 17 provides extra strength for the wide portion of the roof truss. Dimension: approximately 1/2 x 1/2 inch.

HOW

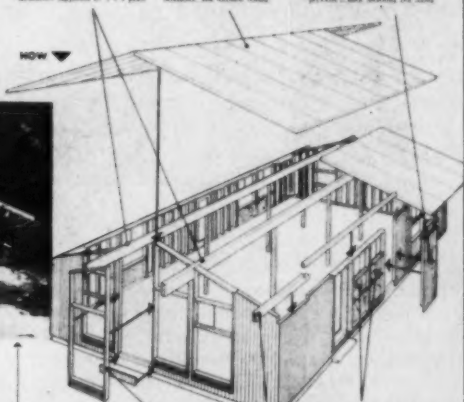

VIEW OF HOUSE from the rear. The wood bracket from registered view is right to better connect at the end.

WOOD BRACKET 4 x 17 provides extra strength for the wide portion of the roof truss. Dimension: approximately 1/2 x 1/2 inch.

WOOD BRACKET 4 x 17 provides extra strength for the wide portion of the roof truss. Dimension: approximately 1/2 x 1/2 inch.

WOOD BRACKET 4 x 17 provides extra strength for the wide portion of the roof truss. Dimension: approximately 1/2 x 1/2 inch.

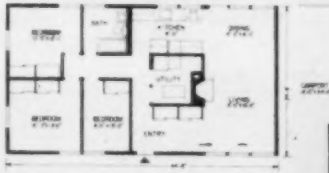

How to build it

Only one magazine does both
for your buyers in light construction

What to build—how to build it is the happy balance of realistic reading that themes American Builder from cover to cover. Its prolific, fast-moving 19-man editorial team digs into the problems of big, middle-size and small builders . . . probes the salient new developments of both light commercial and residential construction . . . cross-sections big cities and small towns across the country . . . and presents its clear, sharply illustrated reports in the language builders understand.

Surely no magazine is more replete with thought-starters to spark more business for builders . . . spur more builders to buying action. No light construction paper can match the quality and volume of its editorial content . . . none duplicates its unique *what-how* format . . . no other's audience is so responsive . . . its big 107,730 circulation tops every magazine in the market. Here then is the best place for you to sell light construction . . . American Builder! *Simmons-Boardman Pub. Corp., New York 7, N. Y.*

More builders subscribe to

AMERICAN BUILDER (ABC-ABP)

than to any other light construction paper

1956 is your year to fix



SALES BUILDERS FOR HOME BUILDERS

New ideas to help you sell more remodeling . . . using products available from your U.S.G. building materials dealer

An increase in remodeling sales is just one of many ways you can benefit from United States Gypsum's ever-increasing service to home builders. Make use of the new ideas, methods and quality materials that are continually being developed to make your business more profitable.

THERE'S A BRIGHT IDEA FOR A SALE in a bright new attic room like this. Triangular glass and picture window area admits light; USG® Insulating Twin-Tile reflects it from the ceiling. Bleached Mahogany finish SHEETROCK®, the fireproof gypsum wallboard, gives walls the appearance of natural wood. USG Perforated Hardboard, finished with TEXOLITE® DURAVAL® Latex Paint, conceals unsightly beam, serves as an indirect lighting fixture; provides backing for built-in bookcase.



the greatest name in building

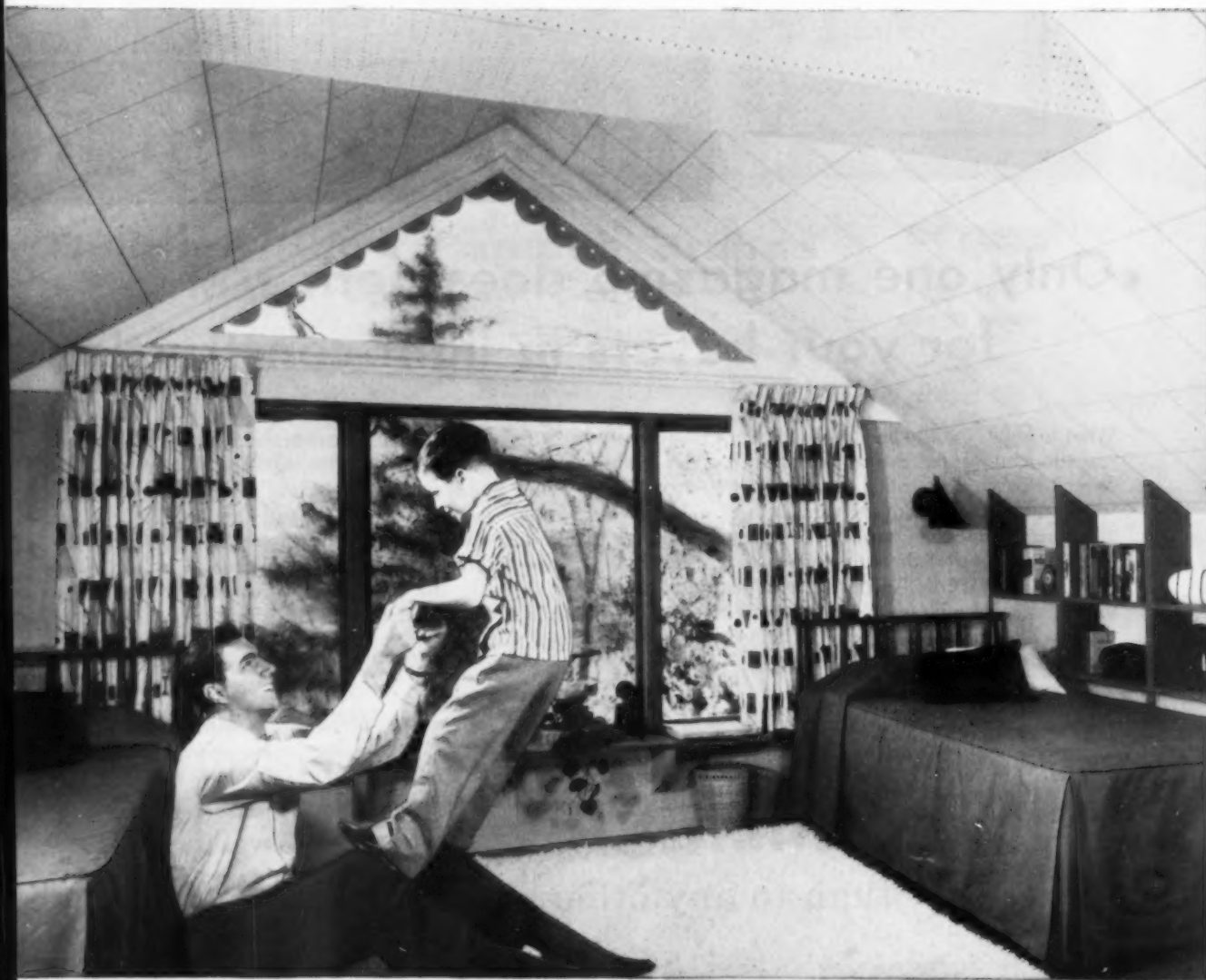



BASEMENTS ARE YOUR BEST SALES BET for family rooms. A minimum of windows means a maximum of privacy. That's why a basement makes the perfect place for a play-and-party room, like the one shown above. USG Panel-Tile goes up quickly on the ceiling, insulates as it decorates, simplifies boxing of ductwork. SHEETROCK in one of three woodgrained finishes provides warm-looking walls that are in perfect harmony with the cheery red-brick fireplace.

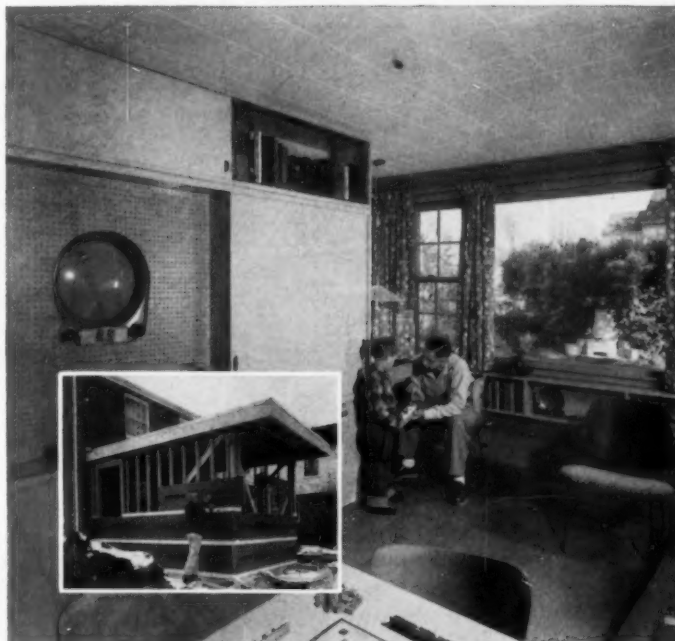

ADD A ROOM FOR ADDED PROFIT. Start by protecting the frame with USG Sheathing. Insulate with RED TOP* Mineral Wool. Then you're all set to produce a family entertainment center in a bright new setting. "Wide screen" cabinet-wall includes: built-in TV, framed with USG Perforated Hardboard; desk and sewing unit; storage space for toys, books, utility items. Fireproof SHEETROCK walls are beautifully decorated with TEXOLITE DURAVAL Latex Paint. QUIETONE* Acoustical Tile on ceiling controls sound.

*T. M. Reg. U. S. Pat. Off.



For complete information on products shown here, fill in this coupon and mail it to United States Gypsum, Dept. AB-62, 300 West Adams St., Chicago 6, Illinois.

- | | |
|---|---|
| <input type="checkbox"/> USG Insulating Twin-Tile | <input type="checkbox"/> RED TOP Insulating Wool |
| <input type="checkbox"/> SHEETROCK Gypsum Wallboard | <input type="checkbox"/> USG Panel-Tile |
| <input type="checkbox"/> USG Perforated Hardboard | <input type="checkbox"/> USG Sheathing |
| <input type="checkbox"/> TEXOLITE DURAVAL Latex Paint | <input type="checkbox"/> QUIETONE Acoustical Tile |

NAME _____ (Please print)

FIRM _____

ADDRESS _____

CITY _____ STATE _____



The merit of a window can be measured in many ways.
 There's **QUALITY, PERFORMANCE** and **STYLE**
 for customer satisfaction and easier sales. There's
ECONOMY of labor in **EASE-OF-INSTALLATION**
 ...a direct result of **SUPERIOR CONSTRUCTION**
 and **RIGID FACTORY INSPECTION**.

Whether you use one or all of these yardsticks, you'll find
WOODCO E-ZEE Loc Wood Awning Windows not only
measure up but surpass all others in every respect.



Hotel Evans, Loch Sheldrake, N. Y.
 SYDNE SCHLEMAN Associates
 Architects
 Middletown, N. Y.

CHECK THE WOODCO E-ZEE Loc PATENTED FEATURES:

- EASY TO LOCK
- SEQUENCE AIR CONTROL
- TOXIC-TREATED TO PREVENT DECAY
- EXTRA HEAVY SASH and FRAME
- DOUBLE VINYL WEATHERSTRIPPING (Pat. Pend.)
- WATER-REPELLENT TREATED
- COMPLETELY ASSEMBLED



for the Beautiful point-of-view...

For further information see your dealer or write to
WOODCO CORPORATION
 Formerly General Woodcraft Co., Inc.
North Bergen, N. J.
 Branches: **LOWELL, MASS., SCHENECTADY 3, N.Y.**

Wholesale Millwork Div.
 ROCKWELL of RANDOLPH, Inc.
 Randolph, Wisconsin

FACTORIES

E-ZEE Loc Wood Awning Div.
 WOODCO CORPORATION
 Jacksonville 1, Fla.



Best way to put up ceiling tile: Use a Bostitch T5-8 Tacker with Bostitch 9/16" or 1/2" staples. Press nose of tacker firmly into cove formed by tile flange. Squeeze the lever. You can drive three staples 4" apart in about three seconds and go on to next tile. You never mar the face of the tiles, and you can wear gloves to keep them clean.



Fastest way to apply insulation: Use either the Bostitch T5-8 Tacker or H2B Hammer, with Bostitch 3/8" staples. The hammer is faster with a little practice. You can drive staples with a flick of your wrist—*much* faster than hammer and nails. One hand is free to position the insulation. Available at your building supply dealer or local Bostitch office.

Install ceiling tile and insulation the way leading manufacturers approve

In co-operation with leading makers of ceiling tile and insulation, Bostitch has prepared a booklet which gives detailed instructions for installing these

materials. The following firms have contributed important information for this booklet and approve this method of installation.

Armstrong Cork Company	makers of Temlok® Tile, Temlok® Plank and Cushiontone®.
The Celotex Corporation	makers of Celotex Tile Board and Finish Plank and Celotex Regular and Reflective Rock Wool Blankets.
Infra Insulation, Inc.	makers of Infra Multiple Aluminum Thermal Insulation.
Minnesota & Ontario Paper Company	makers of Insulite Tile Board, Plank, and Interior Board.
National Gypsum Company	makers of Gold Bond Insulation Board Products and Rock Wool Insulation.
Reynolds Metals Company	makers of Reynolds Reflective Aluminum Insulation.
Simpson Logging Company	makers of Decorative Tile Board, Acoustical Tile, and Insulating Board.
United States Gypsum Company	makers of Twin-Tile, Panel-Tile, Quietone, Auditone, USG Insulation Plank, and Red Top Insulating Wool.
American Sisalkraft Corporation	makers of Sisalkraft and Sisalation.
Wood Conversion Company	makers of Balsam-Wool and Nu-Wood Ceiling Tile.

FREE BOOKLET — SEND COUPON FOR YOUR COPY

BOSTITCH, 827 Mechanic Street, Westerly, R. I.
Please send me your free booklet describing the best way to install ceiling tile and insulation.

Name _____
Address _____
City _____ Zone _____ State _____

Fasten it better and faster with





the
**LUXURY
LOOK**

Guaranteed Styron
Plastic Wall Tile
adds the modern touch
of luxury
your prospects look for

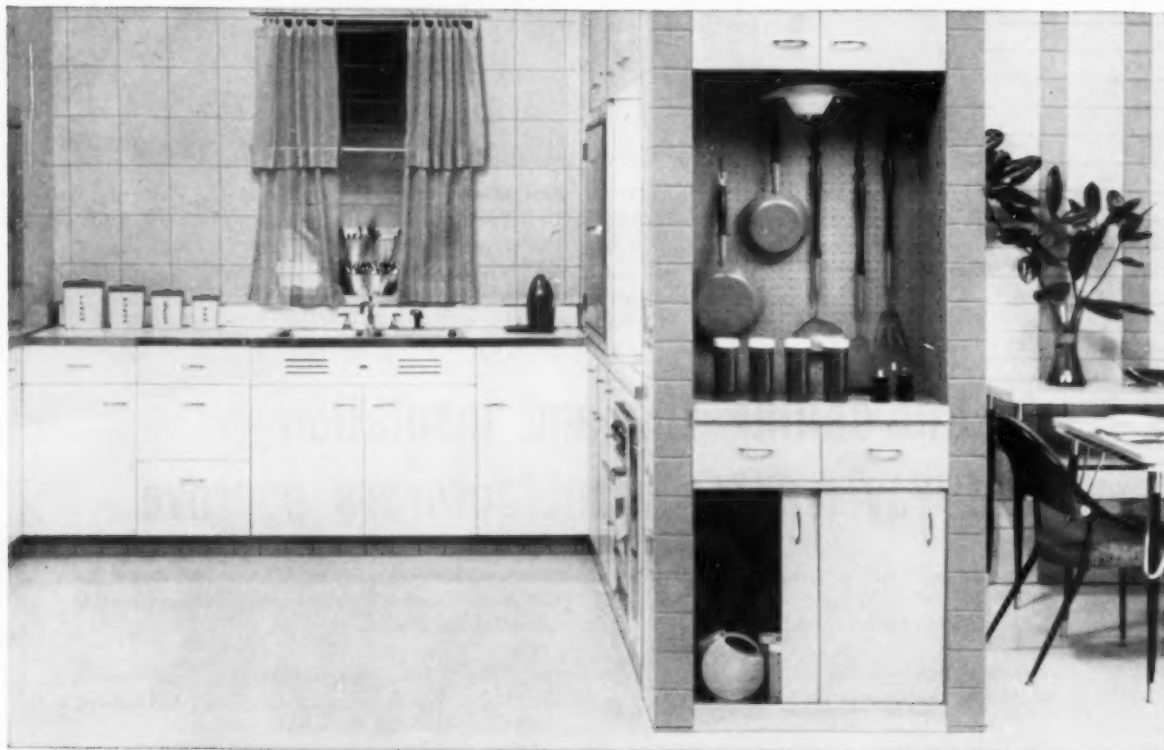

FIRST THING you notice about plastic wall tile made of Styron® is that it has unlimited design possibilities. Over 50 modern decorator colors in three exciting shapes tell you that.

Then when you start bringing these possibilities to reality, you come to the pleasant realization that these handsome Styron tile and trim pieces are real money savers. Quick and easy to install, they eliminate costly wire lath preparation, cut down crew time by plenty.

Best thing of all about Styron wall tile is this: The certified dealer you buy it from guarantees its quality in writing. Prospects know this guarantee, and they'll react favorably to your good judgment in having chosen the wall tile that carries it.

We call the growing trend to permanent plastic wall beauty The Luxury Look. You'll call it sound building practice.





See how the luxury look of Styron wall tile enhances this lovely bathroom setting. Might easily be the most talked about room in the house! Practical, too. Colors won't chip or peel—tiles stay luxuriously smooth and beautiful. Styron tiles are the soul of simplicity in maintenance—fingerprints or splash marks wipe clean in a jiffy with a damp cloth.

You'll find dozens of different ways to add permanent color and beauty to your homes and small buildings with Styron wall tile. Kitchens, baths, laundry rooms, utility rooms, recreation rooms, vestibules, lobbies, hallways—anywhere you choose, guaranteed plastic wall tile made of Styron is your most practical wall covering choice.

Here are your guides to the right choice in Guaranteed Plastic Wall Tile



First thing to do is get in touch with a certified dealer of guaranteed plastic wall tile. You can identify him by the emblem at the left. He is a progressive businessman who will give you a written guarantee (center) that the plastic wall tile and mastic he sells you conform to quality standards established with the National Bureau of Standards. He can guarantee that tile, adhesives and installation meet minimum property requirements for F. H. A. loans. The

famous Styron label (right) identifies tiles made of dependable Dow polystyrene. When you install Styron plastic wall tile in any building, you're getting the benefit of the best-established prestige name in the industry. There's the package: THE LUXURY LOOK, guaranteed Styron plastic wall tile—and more building profits for you! For further information, write THE DOW CHEMICAL COMPANY, Midland, Michigan, Plastics Sales Dept. PL459M-1.



Cash in on giant ohi with the new



This giant Operation Home-Improvement "package" is designed to let you take full advantage of the tremendous home-remodeling market . . . to help you really build your profits this fall. And you'll be backed to the hilt by the nationwide ohi fall push, topped off with a special advertising section devoted to home-improvement products in the September 29 issue of The Saturday Evening Post!

Post section plus new kit to aid builders and contractors to large profits

No doubt about it, millions and millions of families plan to remodel this year, so why not get your share of this huge market! This 40-piece Post promotion kit, containing hard-selling posters, banners, sales talkers and

newspaper ad mats, ties you in with the famous brands advertised in the Post section . . . each one imprinted on a colorful pennant. And an 8-page Idea Plan Book includes practical suggestions on the use of this material, plus ideas for local newspaper, radio and TV advertising. Your own Association is behind ohi . . . the ohi symbol gives added weight to the timely Fall Home-Improvement Fair theme, "Be wise, modernize . . . have your home of tomorrow, today!" Reserve your kit today, only \$2.50, and worth far more in profits to you. Kits will be mailed 3 weeks before this special Post hits the newsstands.

Remember, ohi was created for you. Make your own special promotion plan and profit from the terrific impact this Saturday Evening Post section is going to generate. Make it your biggest year ever!

**The Saturday Evening
POST** — gets to the heart of America

Fall Promotion Post Promotion Kit

be wise... modernize... have your home of tomorrow... today!

with quality products POST

FALL Home Improvement FAIR

AS ADVERTISED IN The Saturday Evening POST

be wise... modernize... have your home of tomorrow... today!

with quality products POST

FALL Home Improvement FAIR

OPERATION 50th year to FIX HOME IMPROVEMENT

IDEA PLAN BOOK

with quality products POST

be wise... modernize... have your home of tomorrow... today!

with quality products POST

FALL Home Improvement FAIR

be wise... modernize... have your home of tomorrow... today!

with quality products POST

FALL Home Improvement FAIR

Mail coupon today

Channing Way, Manager, Building Products AB Division
The Saturday Evening Post, Phila. 5, Penna.

This is my order for () Post promotion kit(s) for the
ohi fall program. Here's my check (or money order) for
() @ \$2.50 to the order of The Curtis Publishing Co.

Name _____
 Name of Company _____ My Title _____
 Address _____
 City _____ State _____

the newest addition
to a famous insulation line—

BALSAM-WOOL with REFLECTIVE LINERS

Balsam-Wool—with its proved advantages of high efficiency...wind and moisture resistance...extra ruggedness...clean, easy handling—introduces the newest “member of the family”—Balsam-Wool with Reflective Liners. This new addition of Balsam-Wool insulations is an effective answer to summer cooling, air conditioning economy plus winter comfort!

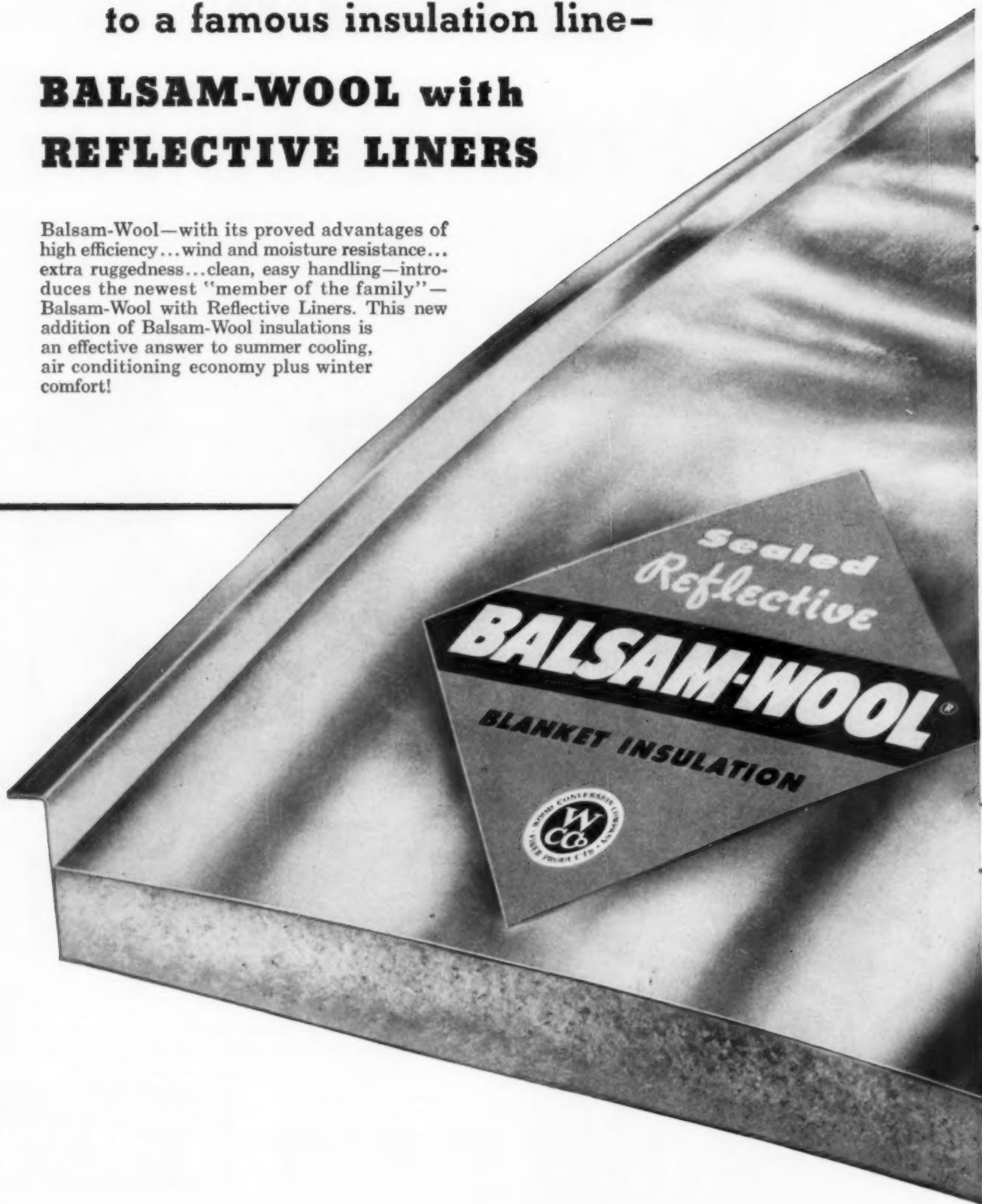



**Especially developed for air conditioning economy—
summer comfort—with the exclusive Spacer Flange!**

This newest Balsam-Wool blanket insulation combines reflective liners with an "old" Balsam-Wool exclusive advantage—the Spacer Flange that positions the blanket to provide important air spaces on either side of the insulation. These flanges make correct application easy, assuring air spaces which are essential for proper performance of reflective surfaces.

Again—a SEALED blanket insulation!

Balsam-Wool's insulating blanket is enclosed (as are all Balsam-Wool insulations) for extra protection. The flanged liner of aluminum foil provides a vapor barrier as an integral part of the new blanket. The other reflective liner offers the extra benefit of a rugged wind and heat barrier. Here is 3-way protection...reduces heat transmission by conduction, convection and radiation. For full details, write Wood Conversion Co., Dept. 118-76, First National Bank Bldg., St. Paul 1, Minn.

SOLD BY LUMBER DEALERS ONLY



BALSAM-WOOL

Sealed Blanket Insulation

WITH REFLECTIVE LINERS



don't leave holes ✓

in your insulation....fill them with

Thermopane[®]
INSULATING GLASS

For the same good reasons you insulate the walls of your home, you need to permanently insulate all of your windows. *Thermopane* makes your windows self-insulating, over the years. *Thermopane* gives you:

- Warmer rooms in winter just like your other insulation does
- Cooler rooms in summer " " " " " "
- Savings in heat bills " " " " " "
- Savings in air conditioning " " " " " "
- Quieter rooms " " " " " "
- And no seasonal work—it's permanent insulation;
- it stays in all year " " " " " "

Whether you buy, build or remodel your home, insulate completely—use *Thermopane* in every window. *Thermopane* is sold by local L·O·F Glass Distributors and Dealers (listed under "Glass" in the yellow pages).

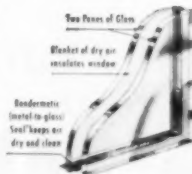

Thermopane INSULATING GLASS

LIBBEY • OWENS • FORD...A GREAT NAME IN GLASS

One New Jersey builder did it for \$1.25 per month!

Single-glazed his house cost \$18,000

Thermopane all around added \$250

Monthly payments on mortgage \$1.25

So his home-buyers had all the comfort and prestige of *Thermopane* for about the same cost as the cheapest storm sash (and the builder profited instead of a storm sash salesman)

P.S. call your L.O.F. Distributor for the whole story!

This ad ran in the POST, June 23, Watch for full-color ads in other national magazines.

Dozens of

Sales-building ideas in

K&M ASBESTOS DECORATIVE PANELS!

For indoor or outdoor use

When customers want smart, dramatic effects in residential or commercial construction, these handsome decorative panels meet the need perfectly. They're ruggedly durable, light in weight, easy to saw and nail. Naturally gray in color, they take paint attractively.

Used outdoors, these new "Century" panels provide light-and-shadow textures which mask irregular weathering and staining. They are highly resistant to fire, vermin, rot and weather.

ARCHITECTS AND BUILDERS put new K&M Decorative Panels to work everywhere! Here, both fluted and lightweight corrugated asbestos sheets are used to restyle this office entrance. Imagine the demand for these new, versatile building materials that provide clean-lined beauty, superior fire protection with less maintenance.

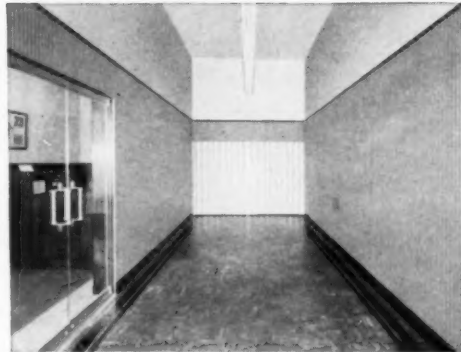

ARCHITECTS AND BUILDERS put new K&M Decorative Sheets to work everywhere! Here, both fluted and lightweight corrugated asbestos sheets are used to restyle this office entrance. Imagine the demand for these new, versatile building materials that provide clean-lined beauty, superior fire protection with less maintenance.

FLUTED ASBESTOS PANELS

Wide ribs provide a strongly-contrasting light-and-shadow pattern. Recommended for use by themselves or as contrasting panels with plain sheets. Especially effective when used for facades, soffits, mullions, dadoses, friezes. Narrow widths provide distinctive cover fillets, borders, architraves and marginal strips. Approximate size: 4' x 8' x 3/8".

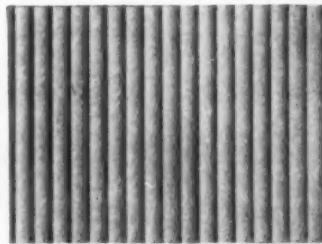

RIBBED ASBESTOS PANELS

Narrow ribs running the full length of the panel form a modern, closely-textured pattern. Highly effective as complete interior wall lining for small rooms. These panels are particularly recommended for use as dadoses, wainscoting, friezes, contrasting panels and marginal strips. Standard size: 4' x 8' with an approximate overall nominal thickness of 1/4".

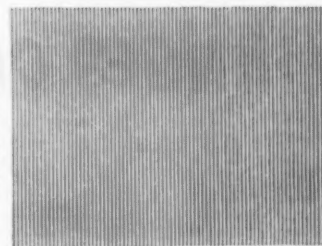

Contact your K&M Distributor, or send in the coupon!

KEASBEY & MATTISON
COMPANY • AMBLER • PENNSYLVANIA



KEASBEY & MATTISON

COMPANY • AMBLER • PENNSYLVANIA

Send me literature and samples of your new fluted and ribbed K&M Decorative Panels

I also want information about:
 K&M Lightweight Corrugated Asbestos Sheets

K&M Flat Sheets

Apac Linabestos Sheetflexlog

Name.....

Firm.....

Address.....

City.....Zone.....State.....

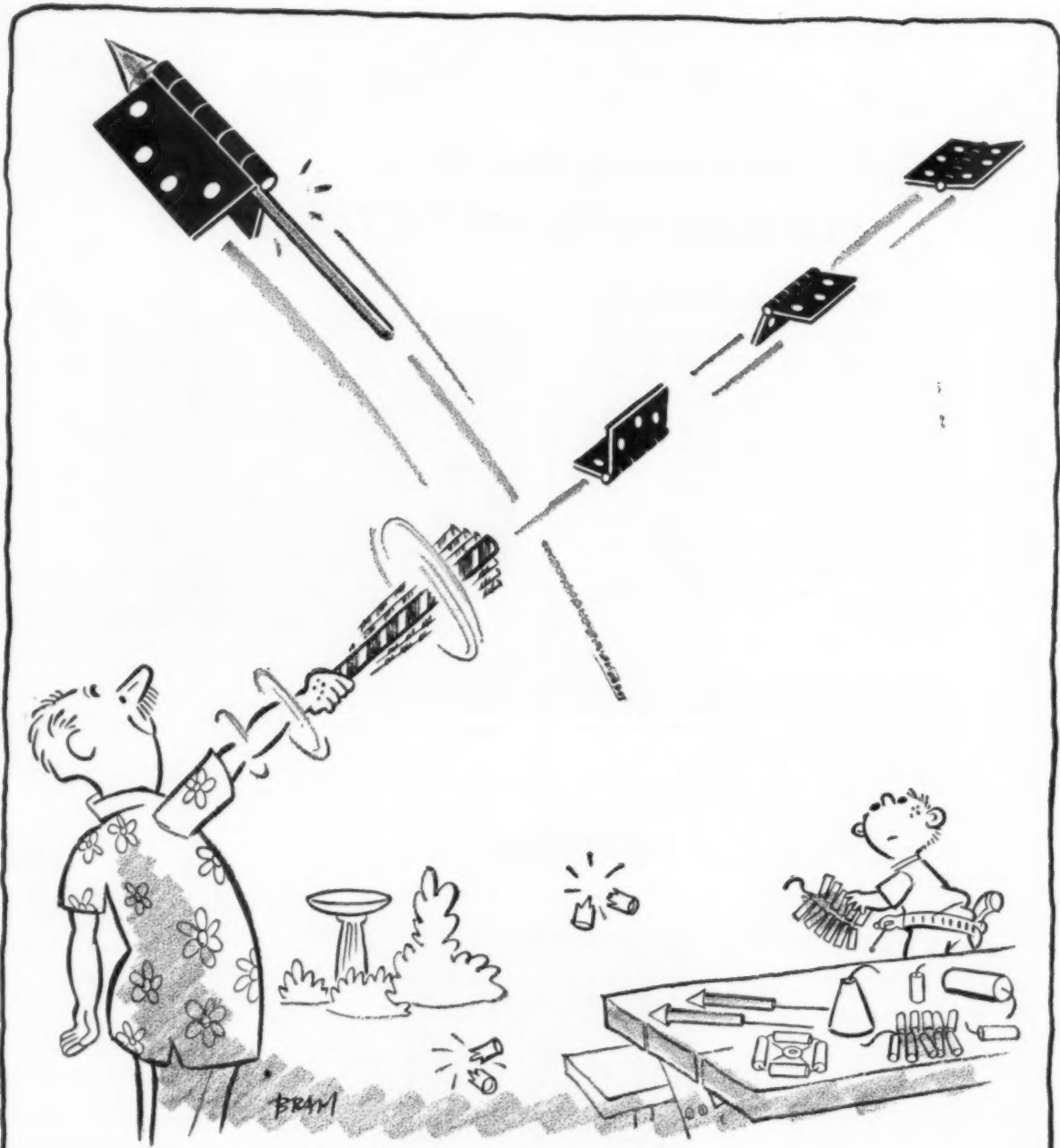

"EVERYTHING HINGES ON HAGER!"*

C. Hager & Sons Hinge Mfg. Co. • 139 Victor Street • St. Louis 4, Mo.
 Founded 1849—Every Hager Hinge Swings on 100 Years of Experience





The extra features sell homes in today's market. And, the first place the home-buyer expects "extras" is in the kitchen. After all, Mrs. Home-Buyer spends much of her time there . . . and she's often the final word in a home purchase.

SELL THE LADIES WITH

Long-Bell Natural Wood Kitchen Cabinets

Whether it's a thousand-unit project, a single-unit job or a remodeling contract, builders, contractors and architects rely on the sales-appeal of Long-Bell Natural Wood Kitchen Cabinets. The great variety of finishing and decorating effects possible and their easy operation are sure-fire features housewives want. Here's *custom beauty* that costs no more than less attractive cabinets — and the women love it.

Long-Bell has always been first to introduce such exclusive features as the full-depth sliding shelves that come to you for storage — and adjustable shelves for perfect adaptability to each housewife's storage setup.

It's easy to plan with Long-Bell Kitchen Cabinets because they're engineered on a 3" module for accurate fit.

Long-Bell maintains big inventories of completed cabinets of beautiful rift grain fir and mellow birch in a full range of sizes — ready for immediate shipment. That's why there are satisfied Long-Bell customers all over the United States. They know that Long-Bell gets the order to the job on time, ready for placement.

Ask your Long-Bell representative to show you the many cabinets, including special-purpose cabinets and accessories that are available.

The Long-Bell Lumber Company.

Established 1875
 Eastern Division — Kansas City 6, Mo.
 Western Division — Longview, Wash.

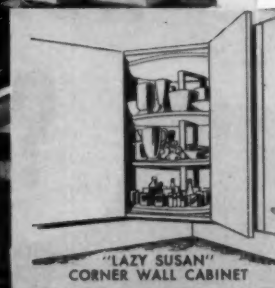

Long-Bell Lumber Company, Dept. AB
 Longview, Washington

Please send me FREE descriptive literature, specifications, etc., on Long-Bell Natural Wood KITCHEN CABINETS.

NAME _____

FIRM NAME _____

STREET _____

CITY _____ STATE _____

*"When you can get a premium glass
at no premium in price..."*

*"Sure, why not use it—
and that means AMERICAN!"*



AMERICAN PRODUCT LINE

American manufactures sheet glass with the least distortion and the greatest clarity, whiteness and luster.

LUSTRAGLASS—single and double strength for ordinary glazing.

LUSTRACRYSTAL—economical heavy sheet glass for larger openings and special applications.

LUSTRAWHITE—a picture glass of exceptional clarity and flatness.

LUSTRAGRAY—for better television viewing.

BULB EDGE GLASS—for use as counter dividers, wind deflectors and shelves.

THIN GLASS—for microscope slides and covers. Extremely flat and true to tolerance.

SUPRATEST—a laminated safety glass.

PANAL—a fiberglass-reinforced plastic structural panel.

WATCH OUR PRODUCT FAMILY GROW

The man-with-the-pipe is right! The more glassed-in areas there are on your projects, the more important it becomes to use the whitest, clearest, most lustrous glass you can find. And that *does* mean American LUSTRAGLASS or LUSTRACRYSTAL—for top quality at no extra cost.

● Prove it for yourself on your next job. Ask your American distributor how LUSTRAGLASS can give your client the benefit of more light transmission, and afford the least amount of distortion over large areas . . . how LUSTRACRYSTAL can save you as much as 35% in many applications. *Look in your Phone Directory for the name of the American distributor in your territory.*

WSW 604D

For the finest quality in **MODERN GLASS**

Use **American** 

Made by the **AMERICAN WINDOW GLASS CO., PITTSBURGH, PA.**

Plants at: Arnold, Pa. • Ellwood City, Pa. • Jeannette, Pa. • Okmulgee, Okla.

How much can room dividers mean to home sales?

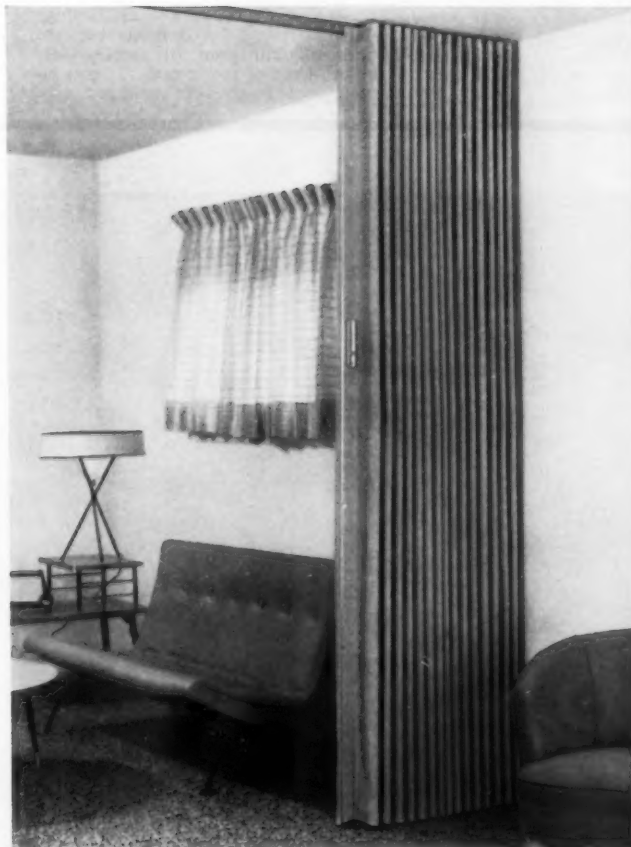

This 8' 10" x 8' room divider is one of the great variety of MODERNFOLD doors available from your distributor. They come in a wide range of colors, finishes and sizes.

© 1956 NEW CASTLE PRODUCTS, INC.

MODERNFOLD distributors
are listed under "Doors"
in city classified
telephone directories.



NEW CASTLE PRODUCTS, INC., New Castle, Indiana • In Canada: New Castle Products, Ltd., Montreal 23 • In Germany: New Castle Products, GMBH, Stuttgart

Bel-Crest Homes Officials give credit to **MODERNFOLD DOORS**



Morrie Mendelson

Louis Scimens

Progressive Detroit
builders Morrie Mendelson
and Louis Scimens of
Bel-Crest Homes, Inc.,
have made extensive use
of MODERNFOLD doors as
room dividers.

"People these days always look for an out-sized living room," state executives of Detroit's Bel-Crest Homes, Inc., "and at the same time, they want an extra room for dining, TV or overnight guests. We're giving them what they want by installing MODERNFOLD doors as room dividers. MODERNFOLD has proved an attractive and easily demonstrated sales feature for us."

Wherever new homes are sold, buyers are alert to nationally advertised MODERNFOLD doors. As room dividers or in doorways, they save space, and afford privacy and flexibility.

Valuable as they are in stimulating sales, MODERNFOLD doors offer additional advantages to builders: low first cost, easy installation, minimum maintenance, and lifetime construction.

New Castle Products, Inc., Dept. G21, New Castle, Indiana

Please send complete information on MODERNFOLD Doors

NAME _____

ADDRESS _____

CITY _____ ZONE _____ STATE _____

Zebra wood...teak wood



Lloyd Moe (left) and Harry Moe, owners of Brentwood Building Corp. in Madison, Wis., now build 15 to 25 homes a year at \$18,500 and up. Their Brentwood Village, platted for 225 homes plus park and professional service center, has about 45 homes, all sheathed with Bildrite.

For \$10,000 homes or \$100,000 homes, Bildrite offers greater bracing strength, better insulation, ease of application, and really important cost savings. Cuts quick and clean with hand or power saw . . . goes on fast . . . reduces your waste to absolute minimum.

INSULITE AND BILDRITE ARE REGISTERED T. M.'S U. S. PAT. OFF.



...and Bildrite Sheathing

"We picked Bildrite solely for quality...yet saved \$65 per M"

...say builders Lloyd and Harry Moe, who also designed this luxurious lakeside home at Madison, Wisconsin.

Valued at close to six figures, the home was built with just one thought in mind—to make everything the best that money could buy. Many

rooms are panelled in rare, costly woods, including teakwood from Africa and zebrawood from the Belgian Congo.

With money no object, what sheathing would you expect a top-ranking builder to use? "In our opinion," say these builders, "there's only one 'best,' so of course we used Bildrite. Yet, compared to wood, it saved us about \$65 per 1,000 feet."

Want full facts on Bildrite? Write Insulite, Minneapolis 2, Minnesota.

build better and save with

INSULITE



INSULITE, Made of hardy Northern wood

Insulite Division of Minnesota and Ontario Paper Company, Minneapolis 2, Minnesota



Kenflex vinyl asbestos tile floors help **clinch home sales!**



Kenflex vinyl costs only **\$4.80** more per room!

Yes, an average 8'x10' kitchen in KenFlex Standard Gauge (1/16") costs about \$4.80 more than Asphalt Tile (Group C Color)...yet it helps you sell homes faster!

BECAUSE IT'S VINYL, it's moistureproof, grease-proof, easier to clean, long wearing. Colors are clearer, brighter. KenFlex added value helps convince homebuyers and sales are easier to close.

BECAUSE IT'S NATIONALLY ADVERTISED, KenFlex is pre-sold for you! Millions know KenFlex floors from the dramatic full color, full page ads appearing continuously in America's best read magazines.

BECAUSE IT COMES IN 3 WANTED STYLES... Corktone KenFlex, Carnival KenFlex, Marbleized KenFlex...you can feature KenFlex in every type of home, in every room. Ideal for slab-construction developments, perfect for kitchens, playrooms in your finest custom-builts, KenFlex Vinyl Asbestos Tile Floors give you new selling advantages that really pay dividends. Call your Kentile, Inc., Flooring Contractor and learn all the facts about KenFlex NOW!

KENFLEX® ...by the makers of **KENTILE FLOORS**

VINYL ASBESTOS TILE
Copyright 1956 Kentile, Inc., 58 2nd Ave., Brooklyn 15, N. Y.

*Reg. U. S. Pat. Off.

KENTILE * KENCORK * KENRUBBER * KENFLEX * KENFLOR * KENROYAL

*Built-in
for
salability*

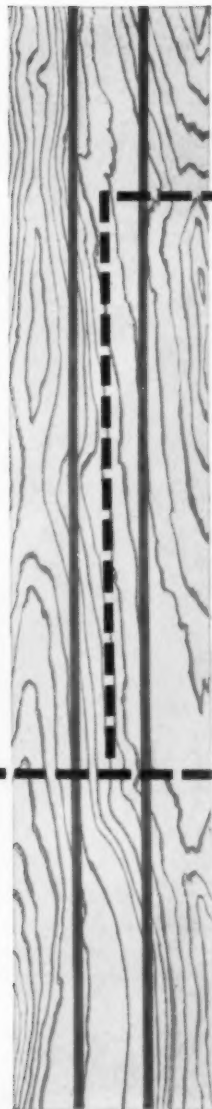

Telephone outlets in the living room, bedroom and kitchen are signs of modern home planning.

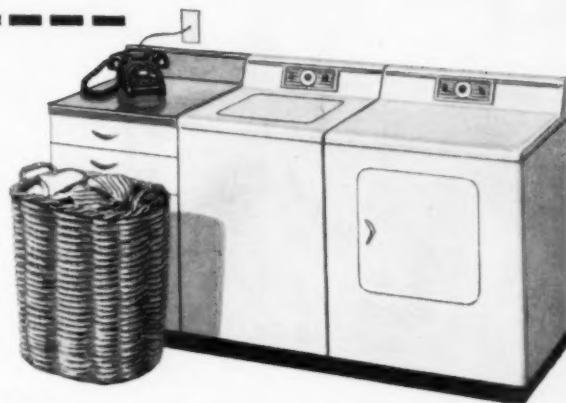

A basement phone is a real convenience, too—saves going up and down steps.

Today's home buyers want convenient telephones around the house —with thoughtfully placed outlets and concealed telephone wiring. Architects with an eye for modern trends put telephone convenience in a class with adequate electrical wiring.

BELL TELEPHONE SYSTEM



Your nearest Bell Business Office will help you with concealed wiring plans. Just ask for "Architects and Builders Service." For details on home telephone wiring, see Sweet's Light Construction File, 8i/Be. For commercial installations, Sweet's Architectural File, 32a/Be.



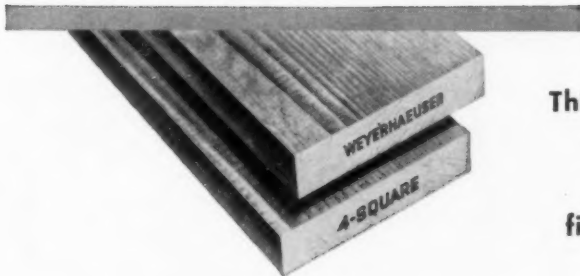

This brand name on lumber
also brings builders
a wide variety of
fine lumber items to...

Attract Home Buyers

Many builders are adding sales appeal to their homes by using and featuring Weyerhaeuser 4-Square Special Line Products. These products are truly outstanding—special items which contribute to the charm and beauty of a home as well as to its structural soundness.

Builders report that featuring such special items is simple and effective. It provides an ideal method of actually demonstrating to the prospective buyer the high quality and the extra value of the home.

Here are just a few of the Weyerhaeuser 4-Square Special Line Products:

... Wood Paneling, in a broad range of rich, beautiful Western woods for dis-

tinguished rooms at modest cost

... Bevel Siding, in a range of widths, offering the friendly charm of wood—plus long life and low maintenance costs

... Glued-Up Lumber, which means a better supply of the highly desirable wide boards and wide siding

... Weyerhaeuser 4-Square Kiln-Dried Lumber, which delivers the plus values of improved dimensional stability.

See these items—and many others—at the office of your Weyerhaeuser 4-Square Lumber Dealer. He also can show you colorful idea books full of practical suggestions for using paneling, siding, and fences to add appeal to your homes... or, write for descriptive literature.

WEYERHAEUSER 4-SQUARE GLUED-UP LUMBER—Because the demand for wide lumber often exceeds the supply, Weyerhaeuser 4-Square Lumber Dealers are featuring edge-glued items. From dealer after dealer comes the same story: "Once a contractor uses 'glued-up', he likes it. Then he buys 'glued-up and/or regular', because edge-glued lumber is graded and used the same as regular stock."

Weyerhaeuser Sales Company

ST. PAUL 1, MINNESOTA





This water closet does not
disturb your peace of mind

The famous Case time-tested Non-Overflow One-Piece water closet
with the whispering flush...produced in 32 decorator colors and spark-
ling black and white. Ask your Case wholesaler or write:*

*PATENTED

CASE MANUFACTURING CORPORATION

33 MAIN STREET, BUFFALO 3, NEW YORK



Photo by Hedrich-Blessing. Furniture by M. Singer & Sons.

America's newest, smartest hardwood floor

Its striking new Midnight Finish has won the enthusiastic approval of architects, decorators and home buyers for Bruce Fireside Plank. Alternating 2 $\frac{1}{4}$ " and 3 $\frac{1}{4}$ " strips of solid oak create the charm of expensive random-width plank . . . with wide, shallow side-bevels to emphasize the interesting, casual effect.

While high in style, Bruce Fireside Plank is low in price . . . in fact, costs little more than a regular strip floor. It's completely finished at the factory for beauty, durability and on-the-job cost savings. Write for color booklet. See our catalog in Sweet's Files.

E. L. BRUCE CO., MEMPHIS 1, TENN.



*Naturally
Beautiful*

Bruce Fireside Plank Floor

Remodel with
KOHLER PLUMBING FIXTURES

Types and sizes for every need

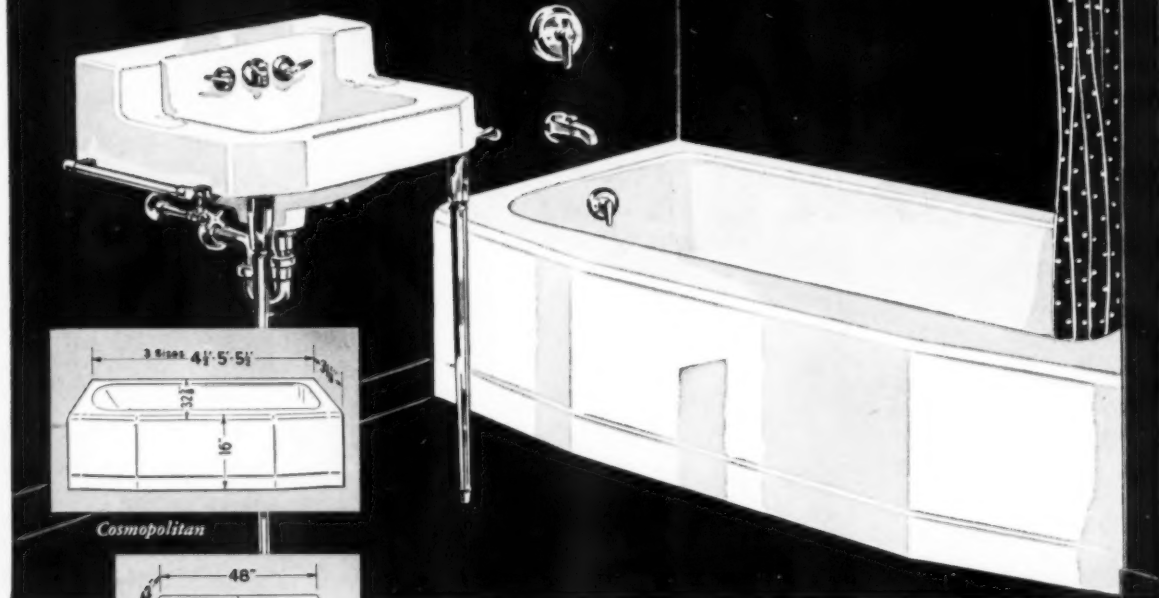

Gramercy lavatory, Cosmopolitan bath

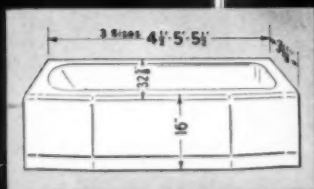

Cosmopolitan

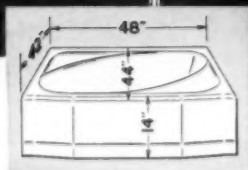

Mayflower, recess

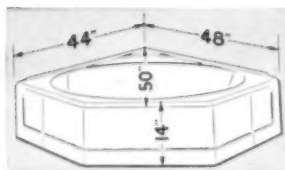

Mayflower, corner

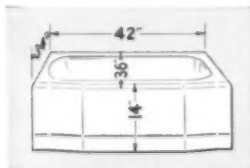

Standish, shower size

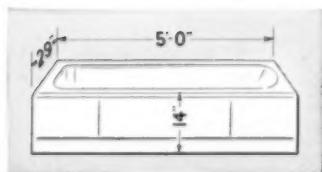

Minocqua

Additional and better bathroom facilities are the "what-we-want-most" item in more and more home-owner planning. You can rely on time-tested Kohler quality to increase your share of today's remodeling market.

The Kohler line provides the wide variety of sizes and types you need to assure best use of existing space when you modernize plumbing facilities. In baths, most crucial in solving space problems, Kohler lengths are graduated from 3½ to 5½ feet; widths from 29 to 44 inches.

Kohler lavatories and closets are consistent in design with Kohler baths; insuring attractive matching sets whichever fixtures are selected. Kohler colors are soft pastels; the white is a lustrous, pure white.

Kohler enameled sinks, too, come in a complete range of widths and lengths—for counter top and cabinets. The enamel on all sinks is acid-resisting, easy to clean and keep clean.

Kohler fittings—all-brass, chromium-plated—conform to the fixtures in style and quality.

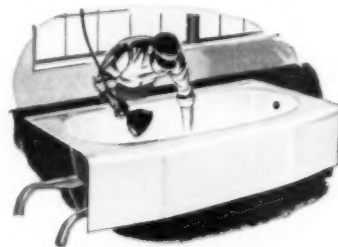

First Quality Only

The enamel of all Kohler baths is inspected under a strong light. Searching tests and inspections are made throughout every step of manufacture.

Kohler Co., Kohler, Wisconsin. Established 1873

KOHLER OF KOHLER

PLUMBING FIXTURES • HEATING EQUIPMENT • ELECTRIC PLANTS
 AIR-COOLED ENGINES • PRECISION CONTROLS

You are entering the **American Builder**

Supermarket



Help yourself to everything you want in new information and literature about new products shown on the pages ahead. This is one-stop shopping for ideas. Instead of writing a dozen different manufacturers, just circle the numbers on the other side of the card below . . . then drop it in the mail (no stamp needed). **AMERICAN BUILDER** will forward your request to each manufacturer, who will send you complete data free of charge. Get your pencil out and help yourself . . .



BUSINESS REPLY CARD

First Class Permit No. 153, Sec. 34.9, P. L. & R., New York, N. Y.

4 cents Postage will be paid by

Business Manager
AMERICAN BUILDER
30 Church St.
New York 7, N.Y.





CIRCLE items below

... and mail this
postcard today

**A HANDY NEW PRODUCTS
INFORMATION SERVICE**



FREE INFORMATION - ON PRODUCTS and EQUIPMENT

WESTERN CATALOGS	7025	7050	7074	7098	7122	7146	7168
	7026	7051	7075	7099	7123	7147	7169
	7027	7052	7076	7100	7124	7148	7170
7001-W	7028	7053	7077	7101	7125	7149	7171
7002-W	7029	7054	7078	7102	7126	7150	7172
7003-W	7030	7055	7079	7103	7127	7151	7173
7004-W	7031	7056	7080	7104	7128	7152	7174
7005-W	7032	7057	7081	7105	7129	7153	7175
7006-W	7033	7058	7082	7106	7130	7154	7176
7007-W	7034	7059	7083	7107	7131		7177
7008-W	7035	7060	7084	7108	7132	CATALOGS	7178
	7036	7061	7085	7109	7133	7155	7179
NEW PRODUCTS	7037	7062	7086	7110	7134	7156	7180
	7038	7063	7087	7111	7135	7157	7181
7001	7039	7064	7088	7112	7136	7158	7182
7002	7040	7065	7089	7113	7137	7159	7183
7003	7041	7066	7090	7114	7138	7160	7184
7004	7042	7067	7091	7115	7139	7161	7185
7005	7043	7068	7092	7116	7140	7162	7186
7006	7044	7069	7093	7117	7141	7163	7187
7007	7045	7070	7094	7118	7142	7164	7188
7008	7046	7071	7095	7119	7143	7165	7189
7009	7047	7072	7096	7120	7144	7166	7190
7010	7048	7073	7097	7121	7145	7167	7191
7011	7049						
7012							
7013							
7014							
7015							
7016							
7017							
7018							
7019							
7020							
7021							
7022							
7023							
7024							

MAIL THIS CARD TODAY — WE PAY THE POSTAGE

PLEASE PRINT NAME AND ADDRESS

FIRM TITLE

NAME KIND OF BUSINESS

STREET

CITY ZONE STATE JULY, 1956

SERVICE ON THIS CARD EXPIRES IN 90 DAYS — ACT NOW!

In addition to 92 remodeling ideas
"up front" in this issue (pages 73 to
103), here are more than 60 others
...all keyed to reply card on page 148

... MORE ABOUT WALLS (starts pp. 80-82)



HARDWOOD PANELING by "Solid-wood" renews a room with ash, cherry, walnut, red or white oak, mahogany or chestnut walls. Pattern has small horizontal grooves, rounded

edges, allows $\frac{1}{8}$ " channel at tongue and groove. In $\frac{3}{8}$ " or $\frac{3}{4}$ " sizes; lengths equaling 8'; 4" to 8" widths. Williams Brownell Inc., Dept. AB, Asheville, N.C. (No. 7095, p. 148).



PLASTIC COATED fabric provides protection and beauty for old walls in one refinishing job. SuperSanitas, in 180 patterns and textures, has colors sealed in by waterproof coat of clear plastic. Goes on easily over almost any wall, acts as vapor barrier. Standard Coated Products, Dept. AB, Buchanan, N.Y. (No. 7096 on page 148).

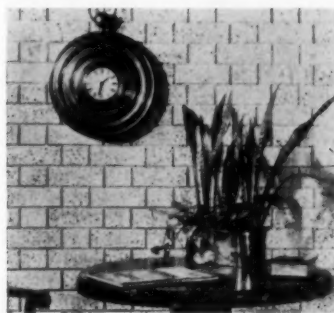

CORK "Decobrik" resembles real brick in texture and size, weighs only 3 oz. a brick, goes on with adhesive, insulates, is in 6 colors. Entec Products Corp., Dept. AB, 1270 6th Ave., N.Y. 20, N.Y. (No. 7093, p. 148).



SCULPTURED TILES add new elegance. Ceramic "Light and Shadow" tiles give dramatic tactile value to wall. For columns, complete walls or sections. Design Technics, Dept. AB, 4 E. 52nd St., N.Y. 36, N.Y. (No. 7094, p. 148).

**MORE REMODELING PRODUCTS
IN THIS ISSUE**

Air conditioning	p. 152
Bathrooms	p. 184
Doors, garage doors	pp. 167, 174
Floors	p. 150
Heating, ventilating	pp. 173, 176
Kitchens	p. 190
Outdoor living	p. 165
Roofing, siding, insulation	p. 158
Windows	p. 150
REMODELING CATALOGS	p. 201

FOR MORE WALL IDEAS, TURN PAGE ▶

... MORE ABOUT WALLS



SNAP-ON-WALLS of perforated hard-board or metal panels snap into extruded aluminum channels which attach to old wall with nails, screws or adhesives. Erdle Perforating Co., Dept. AB, 171 York St., Rochester, N.Y. (No. 7097, p. 148).



TOASTED V GROOVE effect from Markey plywood panels available in firs, redwoods, pine and mahogany. Panels may be nailed unseen through grooves. M & M Woodworking Co., Dept. AB, 2310 Columbia Blvd., Portland, Ore. (No. 7098).



COLORFLEX WALL PANELS, 12"x12," in pyramid pattern, come in Molded laminated plastic; in actual woodflake; in genuine copper-sheeting. Kerco Products, Dept. AB, P.O. Box 228, Lincoln, Neb. (No. 7099, p. 148).

OTHER IDEAS ON WALLS ...

PAGE 80. MORE FLOOR RE-
MODELING IDEAS, PAGE 84

... MORE ABOUT FLOORS: HOW TO



FOR VINYL AND RUBBER TILE installation ... the 3M Brand Tile Adhesive. An easy-handling, water dispersed mastic for laying linoleum, vinyl, cork or rubber tile, the adhesive is suitable for most old and new floors. Minnesota Mining & Manufacturing Co., Dept. AB, 411 Piquette Ave., Detroit, Mich. (Circle No. 7100, page 148).

... MORE ABOUT WINDOWS:



SUN VALLEY sliding glass doors to open up a room. "Sr." or "Jr." lines, both with full jambs, of heavy extruded aluminum, fully weather-stripped. "Sr.": 6'10" high, widths 6' to 20'; "Jr.": 6'8 1/4" high, widths 6' to 12'. Sun Valley Sliding Door Co., Dept. AB, 8354 San Fernando Rd., Sun Valley, Calif. (No. 7104 on p. 148).

STRENGTHEN AND REFINISH THEM (starts on pp. 84-85)



DE-SQUEAKING FLOORS in old house without disturbing polished surfaces or carpeting is possible with Steel-X. A new, 20-gauge, galvanized steel channel bridging, Steel-X replaces or reinforces old wood bridging which has loosened or shrunk with age and makes structure stronger. Bridging needs no nailing, sawing or fitting, snaps into place with one twist. Taber Bushnell Co., Dept. AB, Metropolitan Bldg., Minneapolis, Minn. (Circle No. 7101 on page 148).

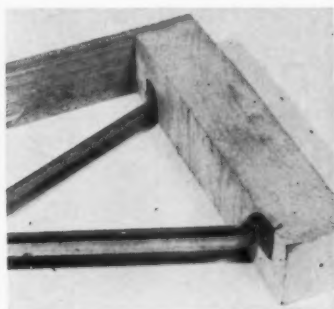

STEEL BRIDGING to strengthen and stabilize floors in remodeling . . . from Sta-Tite Inc. The bridging for wood joists comes in 14 sizes, is easily and quickly installed with a single 4d nail at each end. Flanged-grip ends are driven into the wood and distribute the load independently of nails, producing strong, quiet floors. Also saves construction costs. From Sta-Tite Inc., Dept. AB, 4020 N. Port Washington Ave., Milwaukee, Wisc. (Circle No. 7102 on card, page 148).

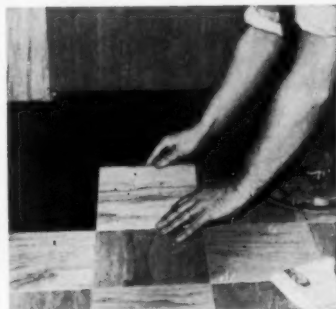

PLYWOOD BLOCK FLOORING to warm and beautify floors goes down like tile. Plyfloor Inc. makes these nine-inch squares of oak plywood installed over floor mastic. Blocks fit neatly in tongue and groove, can also be cut to fit tightly around edges of room. No room for expansion and contraction needed because of compensating effect of cross-ply structure of the blocks. Perry County Plywood Co., Dept. AB, Beaumont, Miss. (No. 7103 on card, p. 148).

7 WAYS TO REMODEL A ROOM WITH THEM (starts on pp. 86-89)



LIGHT, AIR, convenience remodeled into a room with a Malibu aluminum sliding glass door. Capistrano model is completely weatherstripped, with sliding section constructed so that it can be removed. New Mark V economy model is designed so that all panels slide, is also completely weatherstripped. Information on either model from Malibu Manufacturing Corp., Attn. Herbert Shull, Dept. AB, P.O. Box 413, El Monte, Calif. (Circle No. 7105 on card, page 148).

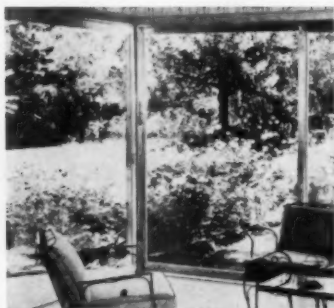

OUTDOORS COME IN with Nudor Installations which open up living rooms, playrooms, patios and porches to outdoor areas. Sliding glass doors, recommended for their beauty, comfort and modern design are shipped preassembled from the factory to assure perfect fit. Doors can be assembled on the job site in less than 15 minutes. Further information from Nudor Manufacturing Corp., Dept. AB 7326 Fulton Ave. North Hollywood, Calif. (No. 7106, page 148).



REPLACING WINDOW sills which have deteriorated or become water-logged is easy with Carrara structural glass, for a practical, attractive sill. Carrara is a non-absorbent, brilliant, mechanically finished material which is impervious to stains, crazing and water and is easy to keep clean. Structural glass sills come in several colors, are $\frac{3}{4}$ " or $1\frac{1}{4}$ " thick, widths up to 5'6". Pittsburgh Plate Glass Co., Dept. AB, 632 Ft. Duquesne Blvd., Pittsburgh 22, Pa. (No. 7107, p. 148).

...MORE ABOUT WINDOWS



WORKING EASE as well as ventilation from Lif-T-Lox windows. Completely removable, with new balance for raising or lowering. R.O.W. Sales Co., Dept. AB, 1322 Academy Ave., Ferndale, Mich. (No. 7108, p. 148).

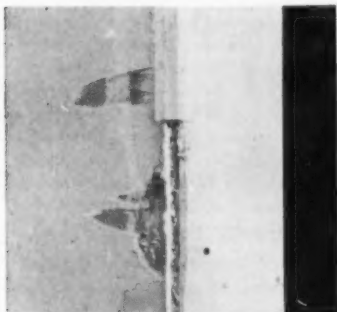

WINDOW TRIM for drywalls. Metal and paper combination needs no nailing, is applied like paper tape. Steel Corner Tape Corp., Dept. AB, 121 133rd St., So. Ozone Park, N.Y. (No. 7109, p. 148).



DRYWALL CORNER bead of metal, Rich-head offers protection to window reveals, walls. Can be used to eliminate casings at doors, windows. Richkraft Co., Dept. AB, 510 N. Dearborn St., Chicago, Ill. (No. 7110, p. 148).

MORE WINDOW REMODELING IDEAS ON PAGES 86-89

... MORE ABOUT AIR CONDITIONING
THE HOME (starts on pp. 74-75)



FOR CASEMENT WINDOWS Airtemp offers Deluxe and Standard models which fit easily into a standard three-light window. No part of the room air conditioner extends outdoors. Beige-finished cabinet, extremely quiet operation. Airtemp Div., Chrysler Corp., Dept. AB, Dayton 1, Ohio. (No. 7111, p. 148).

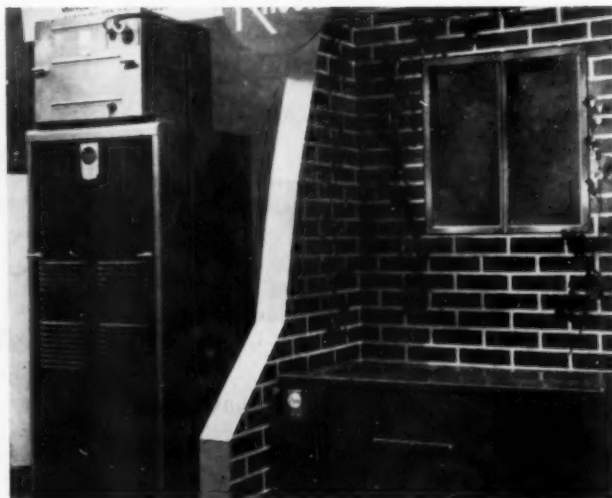

WHOLE HOUSE air conditioning with new Rheemaire system. Cooling section of system, in furnace plenum, is connected by lines to condenser, just outside house. Said to deliver up to 95% more cooling per h.p. unit. Rheem Manufacturing Co., Dept. AB, 7600 S. Kedzie Ave., Chicago 29, Ill. (No. 7112, p. 148).

OTHER IDEAS ON AIR CONDITIONING, P. 156 ▶



High style sells hard... in exciting ELJER ads

Underneath the soft words, there's plenty of hard sell in every Eljer advertisement!

Sparked by colorful decorating ideas like this master bath, Eljer advertising rides the wave of interest in high-style living. It capitalizes on that interest and builds a desire for modern bathrooms. It creates a distinctive, appealing personality for Eljer fixtures as part of the modern home.

You'll find these Eljer ads in America's leading magazines—reaching millions of people every month. You can put their impact to work for you by featuring Eljer fixtures and fittings in the homes you build. See your plumbing contractor or write: Eljer Division of The Murray Corporation of America, Three Gateway Center, Pittsburgh 22, Pennsylvania.

Choose Eljer fixtures from six lovely pastel colors or snowy white.

✱

ELJER

DIVISION OF THE **MURRAY** CORPORATION OF AMERICA



✱ *ELJER - the only name you need to know in plumbing fixtures*



*"This kitchen has everything
I've ever wanted!"*

says Mrs. A. Oliver Ward,
happy homemaker, about the beautiful
American Kitchen in her new home in Paddock Hills,
exciting St. Louis suburban development.



The "Pioneer" kitchen of birch, copper, and steel captivates new home owner in St. Louis

"We had been looking for a house for 3 years," says Mrs. A. Oliver Ward, a new home owner in Paddock Hills.

"When we walked into the kitchen of the Paddock Hills house, I just said, 'Oh, Ollie, this is it,'" Mrs. Ward declared. The American Kitchen was one of the deciding factors, she added.

"I always wanted a built-in oven and set-in range," said Mrs. Ward, "and I'm crazy about the American Kitchens Roto-Tray Dishwasher. It will be so easy

to load and unload."

"This kitchen has everything I've ever wanted," concluded Mrs. Ward, and thousands of smart homemakers throughout the nation echo this homemaker's feelings about American Kitchens.

They fall in love with the "Pioneer"—the stunning new combination of natural birch and antique copper on steel frame. That's why more and more builders everywhere are using American Kitchens to sell their homes faster!



Dishwashers



Ovens



Disposers



Ranges

"American Kitchens are vital factor in selling our houses"

says Herman B. Mayer,
of Mayer, Raisher, Mayer, well known St. Louis
subdivision developers who use American Kitchens with
great success in houses ranging from \$15,950 to \$19,250.



Prominent St. Louis builder features "Pioneer" in Paddock Hills, his new home project

Like more and more outstanding builders everywhere, Mayer, Raisher, Mayer, developers of Paddock Hills, new St. Louis suburb, find that American Kitchens help sell their homes faster.

Paddock Hills is a fast-growing complete model community on a 300 acre tract in northwest St. Louis. The Mayer firm spent nine months developing plans for "woman-planned" homes—and as a result now offer seven completely different floor plans, with emphasis on built-in equipment to satisfy the modern homemaker's needs.

"In the first three weeks when our five display houses were open to the public, there were 35,000 visitors," Mr. Mayer reported.

The kitchen is the key room in the selling of a house. Mr. Mayer has found the "Pioneer" by American Kitchens a very great asset in selling the homemaker.

If you haven't already discovered the advantages of the "Pioneer" and other American Kitchens products, mail the coupon below. Let us prove that American Kitchens sell your homes faster!

American Kitchens

DIVISION  CONNERSVILLE, INDIANA



Ventilators



Accessories

SELL MORE HOMES FASTER!

American Kitchens, Dept. AB-76
Connerville, Indiana

I'd like to have "no obligation" quotation on my next kitchens.

Please send your new Architects' and Builders' File.

Name _____

Address _____

City _____ Zone _____ State _____



NO BLISTERS

with

ARCO ALKYD HOUSE PAINT...

Test panels of Arco Alkyd House Paint and others were weathered outside for four months . . . then attached to a test house for another four months. Inside a 75 degree temperature and a 70% relative humidity were maintained at all times. Arco proved most resistant to blistering. It was also demonstrated that Arco had the best adhesion characteristics.

Why not use Arco Alkyd on your next house? It flows on easily, dries fast . . . is ready for recoating in only four hours. Its beautiful fade resistant colors defy wind, rain and snow—keep that fresh new look for years.

THE ARCO COMPANY
7301 Bessemer Avenue
Cleveland 27, Ohio

Gentlemen:

Please send me Arco's New Color Styling Kit complete with 111 professionally styled color schemes and 56 swatches to guide me in color styling and plot development.

NAME _____

COMPANY _____

ADDRESS _____

CITY _____

ZONE _____ STATE _____

**FREE COLOR
STYLING KIT**

ArcO
PAINTS
TESTED FIRST TO LAST

AMERICAN BUILDER NEW PRODUCTS

AIR CONDITIONING

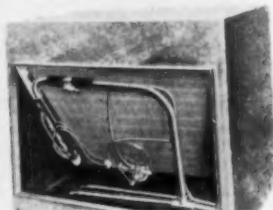

Air-cooled units provide waterless air conditioning

American-Standard provides an answer to waterless air conditioning with its new horizontal air-flow evaporator unit, Model RC-H, designed for use with the company's 2 hp and 3 hp outdoor air-cooled condensing units. Horizontal unit comes in two sizes: 21,600 and 32,500 total Btus. Features include expansion valve with thermally-aged diaphragm to withstand high temperatures during heating season; jacket which can be purchased separately; and evaporator coil which can also be added later. More information from Air Conditioning Div., American Standard, Attn. C. M. Hoover, Dept. AB, 40 W. 40th St., New York 18, N.Y.

Circle No. 7113 on reply card, p. 148

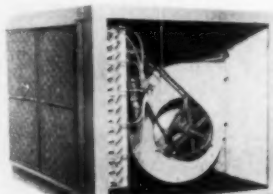

Waterless air conditioners solve shortage problem

Typhoon's new 10 ton low side waterless air conditioning unit is recommended by its makers for solving problems of water scarcity, water impurities or expensive plumbing. Model 10LSU cools, dehumidifies, filters and circulates air through an attached duct system or "freethrow" as a unit cooler. Engineered especially for cooling existing homes equipped with hot water or steam heating systems. Further information from Typhoon Air Conditioning Co., Attn. Mark E. Mooney, Dept. AB, 505 Carroll St., Brooklyn 15, N.Y.

Circle No. 7114 on reply card, p. 148

**MORE AIR CONDITIONING
REMODELING IDEAS, P. 74**



Light, easy-to-handle, Olin Polyethylene makes a permanent moisture barrier when used in slab, full cellar or crawl space construction. Extra wide roll widths make the job that much easier.

It costs you less to build better with Olin Polyethylene



Builders find Olin Polyethylene is of great assistance in sidewall construction . . . retards paint blistering, peeling, staining and helps keep out drafts.

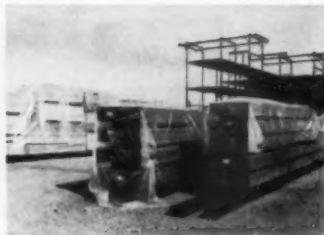

Olin Polyethylene protects machines and materials even over long periods of bad weather. "See-through" quality makes equipment or supplies easy to find.



The work goes on at top efficiency even in bad weather when you close in with Olin Polyethylene.

Whether it's used as a moisture barrier, protective cover, curing blanket, or closing-in material, Olin Polyethylene will usually save you time, labor and do the job better.

Unaffected by most acids, alkalis, bacteria, mold and temperature changes, Olin Polyethylene is a *permanent* moisture, vapor and draft barrier. Discover for yourself how much better, faster and more economically you can build with Olin Polyethylene.

MEETS FHA
MINIMUM
PROPERTY
REQUIREMENTS
. . . FED
SPEC UUP-147
PERTAINING
TO MOISTURE
VAPOR CONTROL

Olin Film Division, 655 Madison Avenue,
New York 21, New York.

Write in for details!

OLIN FILM DIVISION
655 MADISON AVENUE
NEW YORK 21, NEW YORK

Please send me full information on Olin Polyethylene,
and the name of my local dealer.

name _____ title _____

company _____

address _____



OLIN MATHIESON CHEMICAL CORPORATION

NOW, FOR FIRST TIME . . . INSTALL CORRUGATED ALUMINUM



Omark **DRIVE-IT**® Gives These Advantages:

- **SPEED.** Cuts installation time as much as one-half over other methods.
- **STRENGTH.** Stronger, longer lasting, watertight, wind resistant, corrosion proof fastening.
- **SIMPLICITY.** Easy operating *Omark DRIVE-IT* tools are portable, self powered, lightweight. Sales and service nationwide.
- **UTILITY.** Roof can be removed for renovations without tearing.

Corrugated aluminum on steel structures is installed quicker, easier with *Omark DRIVE-IT* powder actuated fastening method. Newly developed special drivepins and insulated cap nut prevent electrolytic corrosion. **It's this simple:** Lay out roofing or siding on steel framing, drive special drivepin through aluminum into the steel; place insulating waterproof washer and cap nut on the drivepin. Actual job tests prove time and cost savings up to one-half over other methods.

See Your Dealer
for
Demonstration
or Mail Coupon
for More
Information

OMARK INDUSTRIES (Formerly POWDER POWER TOOL CO.)

5001 S. E. Johnson Creek Blvd., Portland 6, Oregon

I want more information on fastening corrugated aluminum with
Omark DRIVE-IT tools.

Name _____

Address _____

City _____

© Copyright 1956 by Omark Industries

AMERICAN BUILDER NEW PRODUCTS

ROOFING, SIDING, INSULATION



New brick facings can remodel homes, stores

For a newer "brick look" for houses and store fronts . . . Nailon facing brick. A real brick in appearance, size and texture, it can be nailed to any smooth surface, such as plywood, wood siding, asbestos siding, stucco and concrete block. Brick veneer is about one inch thick and takes mortar in its joints to give finished appearance of complete brick wall. A true clay product, bricks come in two face sizes and in smooth red, weathered or special finish. Remodeled store here of old brick and wood was covered with $\frac{3}{8}$ " plywood and building paper, then finished with Nailon brick. Ludowici-Celadon Co., Attn. C. L. McGee, Dept. AB, 75 E. Wacker Dr., Chicago, Ill.

Circle No. 7115 on reply card, p. 148



New roof rolls on with corrugated aluminum

Barns, utility buildings, vacation cottages can have a remodeled roof easy to install. Illustrated is Quaker State's cross corrugated roll roofing. Made of aluminum, the roofing is described as especially durable, weather-resistant and neat in finish and appearance. Roofing comes in easy to handle rolls, is rolled on and nailed (with a four inch overlap for each roll) with corrugations nesting tightly together. Same material may be used in similar manner for siding. More information from Quaker State Metals Co., Dept. AB, Manheim Pike, Lancaster, Pa.

Circle No. 7116 on reply card, p. 148

Here's a hot weather opportunity for you!

Sweltering days give you an extra selling advantage when you include a "cool" roof in your home renovation offers. That means a roof that keeps out heat as well as rain.



Sell comfort by remodeling with Barrett SNOW-WHITE Shingles

When you're selling remodeling jobs, you're selling new comfort and "looks" for old homes. A new light-colored Barrett Roof will give you a lot more of both in your remodeling packages.

It's a proven fact that Barrett SNOW-WHITE Asphalt Shingles can bounce off enough solar heat to lower inside temperatures up to 15%. This means you can offer your remodeling pros-

pects cooler summers along with the beauty and life-long weather protection of SNOW-WHITE or Barrett pastels of blue, green, red and gray. Make a new Barrett Roof part of your remodeling story. Any Barrett Roofer or Dealer will be glad to show you samples and help you put the famous Barrett name behind your new or remodeling projects.

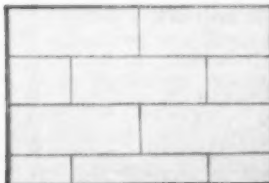

People have been reading about Barrett SNOW-WHITE and pastel shingles in The Saturday Evening Post. Barrett's national advertising helps you sell building and remodeling jobs.

BARRETT DIVISION, Allied Chemical & Dye Corporation, 40 Rector St., New York 6, N. Y., 205 W. Wacker Drive, Chicago 6, Ill., 36th & Grays Ferry Ave., Philadelphia 46, Pa., 1327 Erie St., Birmingham 3, Ala., Melrose Building, Houston 2, Tex.



BARRETT ROOFS

THE GREATEST NAME IN ROOFING



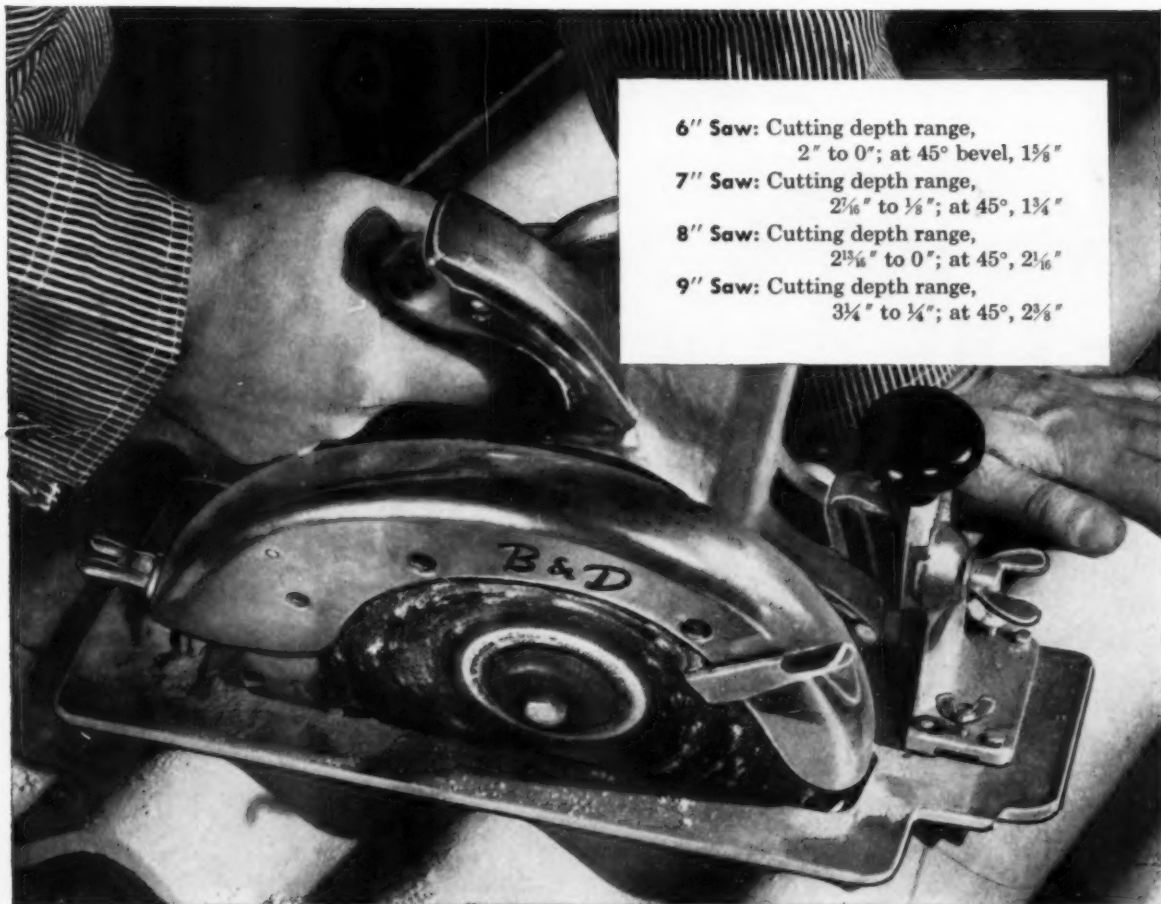

6" Saw: Cutting depth range,
2" to 0"; at 45° bevel, 1½"

7" Saw: Cutting depth range,
2¾" to ½"; at 45°, 1¼"

8" Saw: Cutting depth range,
2¾" to 0"; at 45°, 2¼"

9" Saw: Cutting depth range,
3¼" to ¼"; at 45°, 2¾"

Black & Decker® Heavy-Duty Saws are POWER-BUILT to last!

Professional builders everywhere depend on Black & Decker Saws—6", 7", 8" and 9" models—for power, speed and accuracy. They know that *Power-Built* Black & Decker Saws mean better, faster, less expensive building.

And they know that a B&D Heavy-Duty Saw lasts and lasts—stands up to toughest abuse, under all job conditions, for years of highly satisfactory service. They like the features: easy bevel adjustments; larger steel shoe for safe right or left-hand cuts; overall balanced power and comfortable saw-grip handle for less operator fatigue. Do as other experts do—specify B&D Heavy-Duty Saws. For more information write to: THE BLACK & DECKER MFG. CO., Dept. H107, Towson 4, Maryland.

LOOK IN YELLOW PAGES UNDER "TOOLS-ELECTRIC"



Black & Decker®
PORTABLE ELECTRIC TOOLS

Service . . . one of 42 Black & Decker factory service branches is located "next door" to you. Staffed by experts to give fast, efficient service, genuine replacement parts.

**We don't buy motors
—we build them!**

More than enough power for the job your B&D Saw is designed to do! Each motor built specifically for the individual tool—compact, rugged universal type motors completely built by Black & Decker!

ROOFING, SIDING, INSULATION



Primed siding needs only single coat of paint

Upson's Primed Siding is described as perfect for remodeling projects because of its uniform appearance and texture, ease of application, and savings in time and labor. Siding is made of closely knit fibers welded end for end to give durability and resistance to heat, cold and moisture. Prime coating of synthetic resin emulsion is applied at factory to give tooth which takes paint readily, and smooth working surface for finish coat. Siding is easy to apply, will not split or crack, according to its makers. Comes in standard 12 ft. lengths, 12" widths, 3/8" thick. Information from The Upson Co., Dept. AB, Lockport, N.Y.

Circle No. 7117 on reply card, p. 148



Re-roofing with cedar shingles for new look

Re-roofing, over-roofing or new roofing with red cedar shingles is suggested as a fast and certain method to give a home the look of quality plus maximum, long-life protection. In remodeling jobs, over-roofing can be undertaken even in bad weather due to the protection of the old roof, and the new shingles applied with only a small amount of cutting away and stripping at the eaves, gable edges, valleys and ridges. More information on cedar singles and their uses from Red Cedar Shingle Bureau, Attn. Robert F. Myers Jr., Dept. AB, 5510 White Building, Seattle, Wash.

Circle No. 7118 on reply card, p. 148

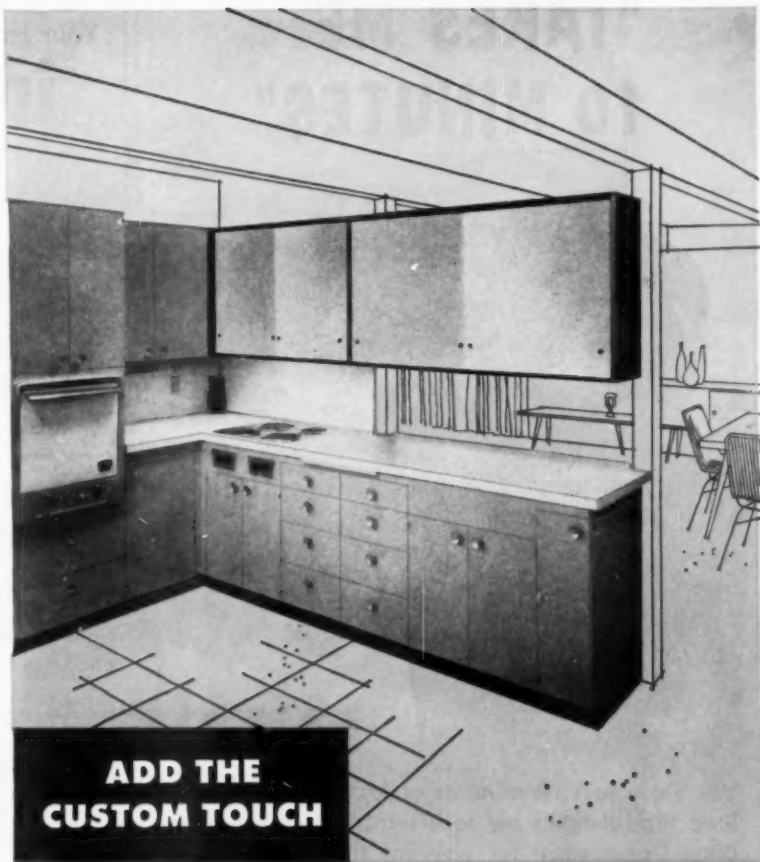

ADD THE CUSTOM TOUCH

with
FIR PLYWOOD KITCHENS

HOW OFTEN IT'S TRUE—the sale is made or lost in the kitchen. That's why it pays to feature the warmth, charm and individuality of fir plywood kitchen cabinets and built-ins in all your homes. No limit to size, design, or color. No juggling of "stock" units—plywood fits your design requirements exactly. It's strong, split-proof, good looking. Easy to cut, fit, fasten and finish.



FREE PORTFOLIO OF FIR PLYWOOD INTERIORS
File folder assembly includes design ideas, specifications, application data. Write (USA only) Douglas Fir Plywood Assoc., Dept. AB, Tacoma 2, Washington.



INSIST ON DFPA GRADEMARKS!

DFPA grademarks assure quality. Standard grades for interior finish are A-A, A-B and A-D (PlyPanel™). Special panels include overlaid plywood... "relief grain" (brushed, embossed and striated panels) ... and Texture One-Eleven™ "grooved."



Plywood of other western softwoods available; look for this DFPA grademark.

"TAKES ME 10 MINUTES"



Yes Sir — just 10 minutes or less that's how little time it takes me to assemble and set a Bilco Door ready for pouring the concrete. And it's my best selling feature!

Cost? None at all. I save money by cutting down man hours during construction with that direct opening to the basement.

A must for
rumpus room
or work shop.
For satisfied
customers and
faster sales
install



Bilco® AMERICA'S FINEST BASEMENT DOOR

Sold by Lumber & Building Supply Dealers.

THE BILCO CO., DEPT. 367-B, NEW HAVEN, CONN.

Please send me complete information on the
BILCO DOOR, sizes, prices and dealers' names.

I build 10 or less 10-100 100-500 houses

NAME _____

ADDRESS _____

CITY _____ STATE _____

Your construction dollar goes farther in

★ **installation**

★ **profits**

★ **sales**

with **CEDARCO**

Aromatic Red Cedar
CLOSET LINING



Fast, low-cost installation is your first advantage. CEDARCO closet lining is tongue-and-grooved with matched ends.

Higher appraisal value is earned—even one closet finished with CEDARCO closet lining increases the value of a home.

House sales go smoother and faster—buyers want the beauty and utility of this genuine Tennessee Aromatic Red Cedar closet lining that protects, never needs painting.

Before you finish another house, match your construction dollar against the installation, profits and sales features of CEDARCO closet lining.

- machine spiral wrapped in cap sealed bundles
- available in different lengths and widths
- guaranteed in writing against moth damage
- nationally advertised in Living for Young Homemakers.

For free CEDARCO Planning Booklet
and name of nearest distributor,

Write:

GILES & KENDALL COMPANY

P.O. Box D, Huntsville, Alabama



ROOFING, SIDING, INSULATION



Savings in warmth plus summer comfort by Alfol

An aluminum foil blanket of reflective insulation is offered by Alfol to insure economical heating and cool summer comfort in both old or new homes. Alfol's layers of aluminum reflects 95% of all radiant heat and resist heat loss by convection. Vapor-proof kraft-duplex backing provides continuous vapor barrier. Alfol comes in rolls, is easy to cut or tear to desired length, goes up on framing with stapler machine. Further information from Reflectal Corp., Attn. S. A. Helfrich, Dept. AB, 310 S. Michigan Ave., Chicago, Ill.

Circle No. 7119 on reply card, p. 148



Roll insulation goes on easily, saves heat

Certain-teed building insulation in rolls is an easy-to-handle method of adding insulation to old homes or to new or remodeled additions. A Fiberglas product, the blankets of insulation may be unrolled between floor joists or nailed to wall studs. Certain-teed recommends four sq. ft. of ventilation for each 1000 sq. ft. of insulated area. Insulation also comes in pouring wool which can be used for insulating uneven and different types of surfaces. Information from Certain-teed Products Corp., Attn. J. E. Midwood, Dept. AB, 120 E. Lancaster Ave., Ardmore, Pa.

Circle No. 7120 on reply card, p. 148

MORE ROOFING, SIDING AND INSULATION REMODELING IDEAS, P. 78



ADD THE CUSTOM TOUCH

with
FIR PLYWOOD BUILT-INS

IT'S EASY to add new convenience and distinction to your homes with fir plywood built-ins. Storage cabinets, wardrobe or built-in furniture—fir plywood is the logical material for any built-in. No other material is so adaptable to specific design and space requirements. Fir plywood is light, strong, good-looking. Takes any finish. Works quickly, easily, simplifies framing—for on-job construction or shop-fabricated units.

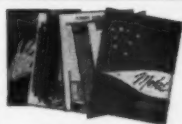

FREE PORTFOLIO OF FIR PLYWOOD INTERIORS
File folder assembly includes design ideas, specifications, application data. Write (USA only) Douglas Fir Plywood Assoc., Dept. AB, Tacoma 2, Washington.



INSIST ON DFPA GRADEMARKS!

DFPA grademarks assure quality. Standard grades for interior finish are A-A, A-B and A-D (PlyPanel). Special panels include overlaid plywood, "relief grain" (brushed, embossed and striated panels) . . . and Texture One-Eleven "graincd."



Plywood of other western softwoods available. Look for this DFPA grademark.

ShoweRite gives YOU
THE WORLD'S BIGGEST



STANDARD SHOWERITE ENCLOSURE

For 4 1/2' or 5' Tub, Suggested Retail Price **\$69.95**
For 5 1/2' Tub, Suggested Retail Price **\$79.95**

Sand blast designs available for Tub Enclosures in handsome Swan, Fish or Sea Horse Designs.

NEW FEATURES AT NO EXTRA COST

- ★ 2 Extruded Aluminum Towel Bars, One Inside . . . One Out
- ★ NEW Noise-Proof Door Slide CHANNEL
- ★ NYLON Rollers—Operate Easily & Quietly on Top Track
- ★ NEW Deeper Bottom Guide Track

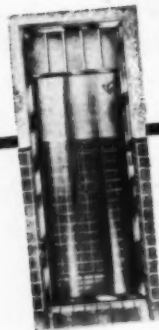

SHOWER DOORS . . .

Completely assembled, hammered frosted glass for easy installation. Continuous piano hinge, drip moulding, with every unit. Easy-to-grip handle. For 24" to 26" openings. Suggested Retail Price **\$39.95**

Model illustrated with grill top Suggested Retail Price **\$49.95**

Your Profits Are Greater With Showe Rite. Send for Complete Facts TODAY.

THEODORE EFRON MFG. CO.
6434 S. Wentworth Ave. Dept. AB-756
Chicago 21, Illinois
Gentlemen: Please rush me information about Showe Rite products.

Name _____
Address _____
City _____ Zone _____ State _____

LEGION



st. to manufacture die-stamped, one piece seamless drawn, stainless steel sinks

Lifetime sinks for Bathroom Kitchen Scullery Laboratory

Style SBL-206-R7 21" x 24"

Style SDBL-2132 21" x 32"

Largest assortment of stainless steel sinks in the world

14 to 20 gauge round, oval and rectangular

a complete line of standard and custom size sink and drainboard units available



For complete catalog write:

LEGION STAINLESS SINK CORPORATION

21-07 — 40th Avenue, Long Island City 1, N. Y.

21 East Van Buren St., Chicago 5, Ill • 420 Market St., San Francisco 11, Calif.



three sales-building touches
of Carrara® Glass!

Beautiful, gleaming Carrara Structural Glass has been put to good use in this sink area . . . for smart, good-looking what-not shelves, window sill and splash panel. Carrara is an ideal material for use in kitchens. It is easy to care for, and its all-pure-glass structure makes it impervious to moisture, steam and odors.

Additional details on this Carrara application are available from your nearest Pittsburgh Plate Glass distributor.



PITTSBURGH PLATE GLASS COMPANY

OUTDOOR LIVING

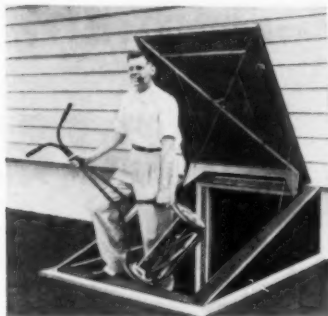

Steel Service-way adds to basement's usefulness

Heatilator's heavy-gauge sheet steel Service-way is electrically welded for maximum strength and durability . . . provides a handy, easily useable work entry into the home. Unit is described as weathertight, with overlapping flanges on frame and door; burglar-proof, with two side bolts on inside lock; easy to open, with spring suspension counterbalancing the weight of the door in all positions. Service-way is assembled and prime-coated at factory; weighs 185 lbs.; has safety-rod by which it may be locked into open position. More information from Heatilator Inc., Dept. AB, East Brighton Ave., Syracuse, N.Y.

Circle No. 7121 on reply card, p. 148

Cellar door can go up in about two hours

Pak-Cel's cellar door unit presents a quick and easy way to gain new use of basement space. Unit comes knocked down with components ready to assemble and install in roughly two hours and 15 min. The all-steel bulkhead unit is placed by two installation men who apply a sealer between all sections, touch up factory undercoating to assure complete waterproofing, and fasten heavy gauge unit to basement wall. Last section to be placed is overhead counter-balanced door which will hold any intermediate position between full open or full closed. Pak-Cel requires 36" opening. Information from Pak-Cel, Attn. Richard P. Gildea, Dept. AB, Box 265, Framingham, Mass.

Circle No. 7122 on reply card, p. 148

**MORE OUTDOOR LIVING
REMODELING IDEAS, P. 98**

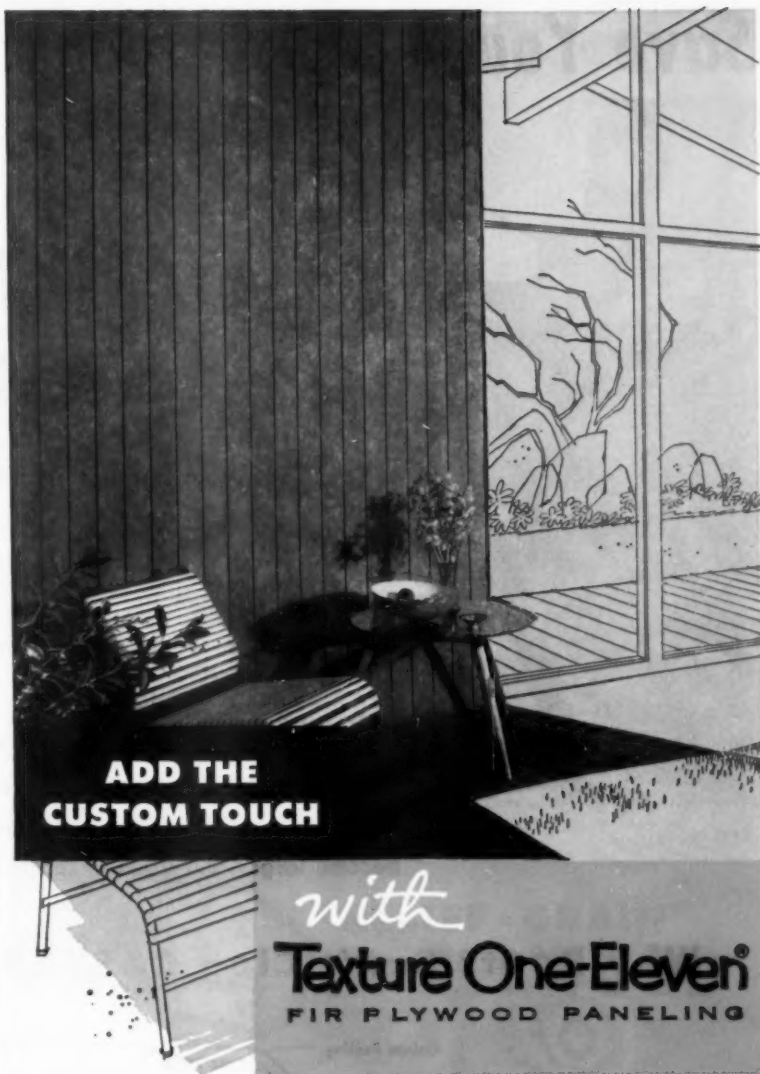

**ADD THE
CUSTOM TOUCH**

with
Texture One-Eleven®
FIR PLYWOOD PANELING

LIFT YOUR HOMES out of the ordinary with exciting Texture One-Eleven fir plywood paneling. Deep parallel grooves and subtle surface texture combine to form a striking feature for any home. Use this new vertical shadow-line plywood for feature walls, ceilings or built-ins. Texture One-Eleven goes up quickly, easily; shiplap edges neatly conceal vertical joints. Grooves are full 1/4" deep, 3/8" wide . . . have sharp, clean-cut edges.



**FREE PORTFOLIO OF
FIR PLYWOOD INTERIORS**
File folder assembly includes design ideas, specifications, application data. Write (USA only) Douglas Fir Plywood Assoc. Dept. AB, Tacoma 2, Washington.



**DFPA
TESTED
QUALITY**

INSIST ON DFPA GRADEMARKS!

DFPA grademarks assure quality. Standard grades for interior finish are A-A, A-B and A-D (PlyPanel®). Special panels include overlaid plywood . . . "relief grain" (brushed, embossed and striated panels) . . . and Texture One-Eleven® "grooved."

WSP
Plywood of other western softwoods available, look for this DFPA grademark.

Save Your Clients Root Reaming Costs

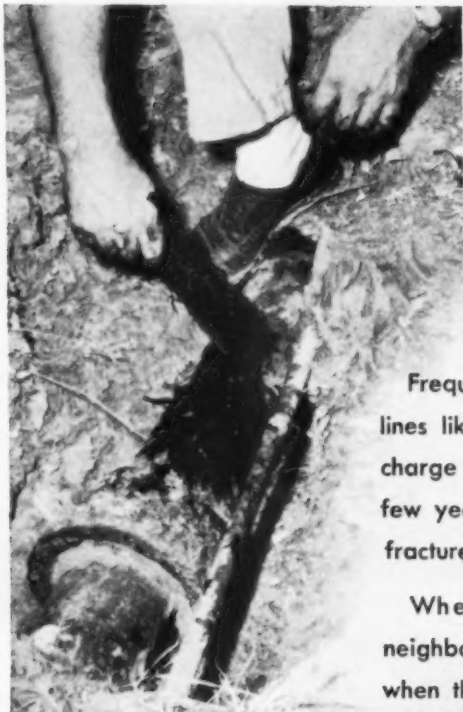

Specify Permanent **CAST IRON SOIL PIPE**

Frequently many families whose homes have non-metallic sewer lines like this have to call the root reaming service. And pay a charge each time roots are cleaned from their clogged pipe. In a few years this adds up to a big expense, even if the pipe isn't fractured in the rodding operation.

Where there are trees around a home--or even in the yards of neighbors--root penetration of sewer lines will invariably take place when the smallest opening develops in a non-metallic pipe joint or pipe fracture. Hair-like roots, growing into small crevices, soon become larger and often force the joint apart.

Why Roots Can't Clog **CAST IRON SOIL PIPE**

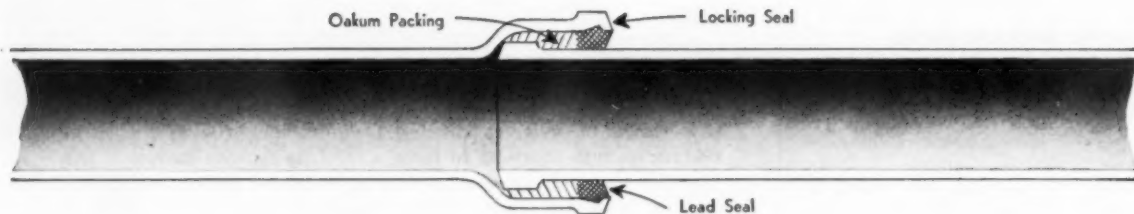

Your client relies on you for the trouble-free future of his home. Specify cast iron soil pipe and save him worry and expense with his vital sewer service as long as his home lasts.

Joints of cast iron soil pipe are packed with oakum, caulked with molten lead—a combination that provides a permanently tight joint that roots cannot penetrate.

WOODWARD IRON COMPANY
WOODWARD, ALABAMA

Our Company does not manufacture cast iron pipe but produces quality iron from which pipe is made by many of the nation's leading foundries.

DOORS



Sliding door hardware will ease installations

For space-saving sliding door installation, Stanley is marketing a set of sliding door hardware, (No. 2800) which can accommodate either 3/4" door or 1 3/8" doors with the same track, hangers and floor guides. The sets come with lengths of track to fit four, five, six and eight-foot openings. Features include jump-proof track, nylon floor guide to fit either thickness of door, permanently lubricated nylon wheels and hangers with shakeproof vertical adjustment. Stanley Works, Attn. E. C. Benfield, Dept. AB, 111 Elm St., New Britain, Conn.

Circle No. 7123 on reply card, p. 148



"Self-storing" combination door in aluminum

A combination aluminum door by Eagle-Picher is called "self-storing" because it comes with two glass and one screen insert to give complete top or bottom ventilation as desired. The aluminum-framed inserts glide up and down in stainless steel channels for easy adjustment to desired position. Complete changeover can be made in a few seconds, claims manufacturer. Three mortised hinges of stainless steel provide additional strength; nylon bearings for free-swinging efficiency. About \$79.95. Information from N. A. Blair, Dept. AB, Eagle Picher Company, 900 American Bldg., Cincinnati, Ohio.

Circle No. 7124 on reply card, p. 148



ADD THE CUSTOM TOUCH

with
**"RELIEF-GRAIN"
FIR PLYWOOD**

OFFER YOUR CUSTOMERS the rich good looks of real wood paneling with inexpensive "relief grain" plywood. The surface is textured (brushed, striated or embossed) to create a striking third dimensional effect that adds warmth and charm to any setting. Ideal for feature walls, ceilings or built-ins. Goes up quickly. Strong, won't crack or split. Takes any finish—including dramatic tone-on-tone effects.

FREE PORTFOLIO OF FIR PLYWOOD INTERIORS
File folder assembly includes design ideas, specifications, application data. Write (USA only) Douglas Fir Plywood Assoc. Dept. AB, Tacoma 2, Washington.



INSIST ON DFPA GRADEMARKS!

DFPA grademarks assure quality. Standard grades for interior finish are A-A, A-B and A-D (PlyPanel®). Special panels include overlaid plywood... "relief grain" (brushed, embossed and striated panels)... and Texture One-Eleven® "grooved."



Plywood of other western softwoods available; look for this DFPA grademark.

If you could buy

good windows

for a penny each.



If you could buy good windows for a penny each your best buy would still be Ualco!

It's less expensive in the long run to use Ualco Aluminum Windows because . . . Ualco Aluminum Windows require no maintenance. They won't rust, warp or rot. Their natural aluminum finish never needs paint. Ualco offers 15 styles of lifetime aluminum Windows . . . the widest single source selection in the industry Ualco Aluminum Windows are complete even to fins, so that they are both economical and easy to install. Ualco Aluminum Windows are designed by architects and manufactured under rigidly supervised standards.

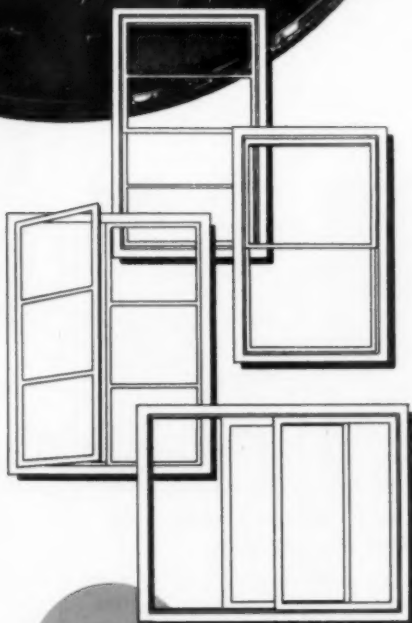

Ualco
U-AL-CO

Aluminum Windows are unconditionally guaranteed against flaws in material or workmanship.

WAREHOUSES AND SALES OFFICES
IN EVERY PRINCIPAL CITY . . .

Canton, Ohio; Elizabeth, N. J.; Hialeah, Fla.;
Florence, Ala.; Montgomery, Ala.; Van Nuys,
Calif.; West Monroe, La.; Asheboro N. C.;
Decatur, Ill.; Chevy Chase, Md.; Bethesda, Md.

World's Largest Manufacturer of Aluminum Windows

Southern Sash
SALES & SUPPLY CO., INC.
SHEFFIELD, ALABAMA

WASHINGTON'S SIMPLIFIED

ROLLING DOOR HARDWARE

universal track in steel or aluminum at new low prices!

and here's the big switch!

**ONE SET OF HANGERS FITS
BOTH 3/4" AND 1 3/8" DOORS**

WITH STEEL...

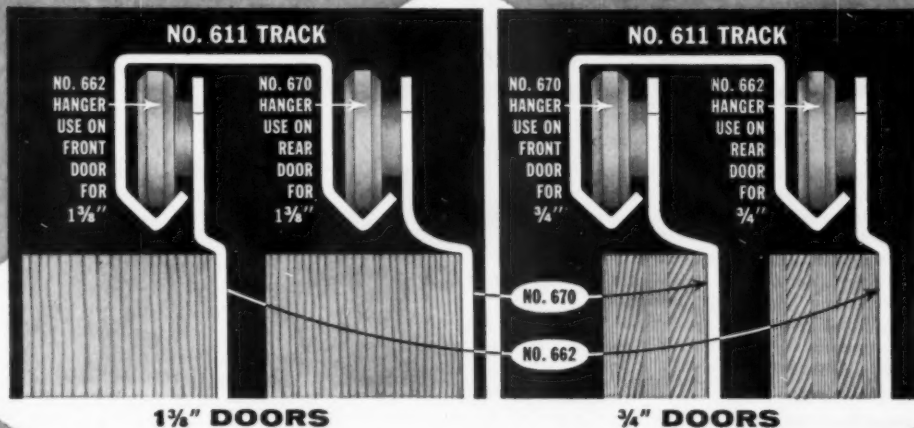

...OR ALUMINUM TRACK

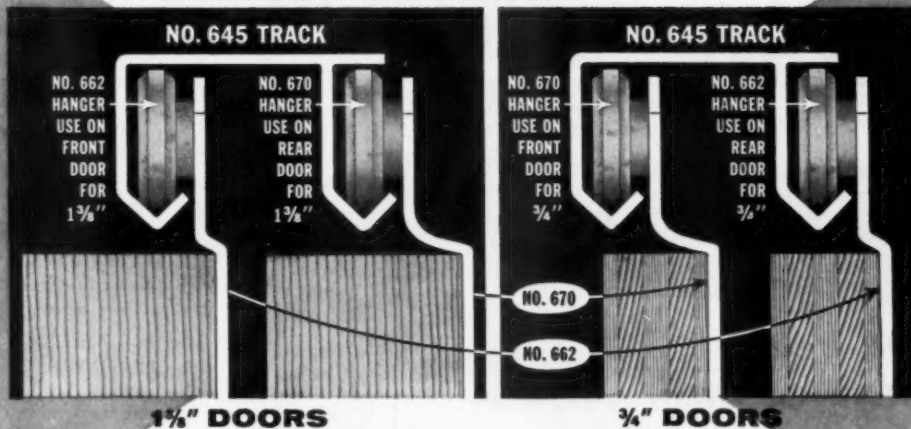

OTHER FEATURES:

- DOORS CAN BE TAKEN OFF TRACK WITHOUT REMOVING HANGERS (A WASHINGTON "FIRST")
- ANTI-JUMP TRACK • SELF-CLEANING "V" GROOVE • LOW COST
- BOTH STEEL & ALUMINUM TRACK AVAILABLE IN BULK & PACKAGED SETS
- INTERCHANGEABLE HANGERS & TRACK • AXLE OR BALL BEARING HANGERS



"Washington" manufactures other types of Rolling Door Hardware including the valance type aluminum track, and the plaster ground aluminum track, plus Wall Pocket Hardware in both aluminum and steel.

For more information on the Washington Line see your dealer, or fill out coupon at right and mail to the manufacturer.

WASHINGTON LINE

DEPT. AB-7 1940 EAST 11TH STREET,
TACOMA 2, WASHINGTON

To: **WASHINGTON STEEL PRODUCTS, INC.**
DEPT. AB-7, 1940 East 11th Street, Tacoma 2, Washington

Gentlemen: Please send me a catalog on Washington Line Rolling Door Hardware, and complete information on the new Universal Track:

NAME

TYPE OF BUSINESS

ADDRESS

CITY ZONE STATE

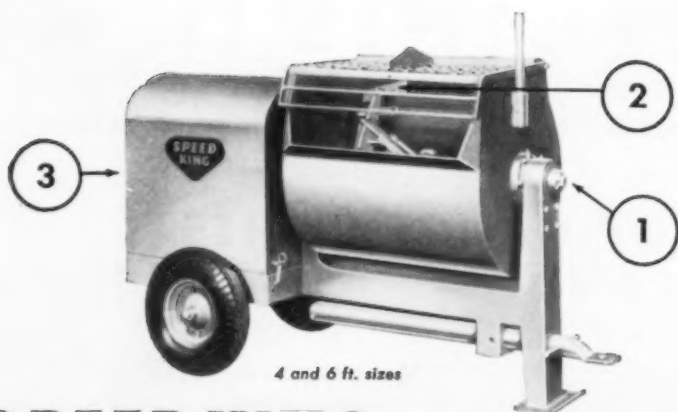

4 and 6 ft. sizes

SPEED KING® fast new mixers

with long-proved Jaeger features

(1) **Timken shaft bearings** have lifetime seals. Used for years in Jaeger plaster-mortar mixers without a single instance of failure where grease seal has been maintained.

(2) **Multi-blade pugmill mixing:** Four sets of 3-blade paddles give a faster criss-cross mix. Produce smoother, easier spreading material. Abrasion resistant drums. Rubber blades, optional.

(3) **Heavy duty engines** (or electric drive). Shift lever engages, disengages power. Send for catalog, low prices, name of dealer.

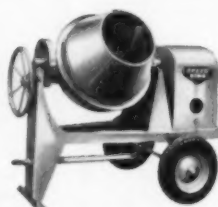

SPEED KING
3 1/2 Tilting
Concrete Mixer

SPEED KING Manufacturing Co., 521 W. Spring Street, Columbus 16, Ohio
Division of The Jaeger Machine Company



The Brand New KICH-N-VENT* COMMUN-A-HOOD

*Pat. pend.

- **SIZES:** 36" to 42" wide.
- **COLORS:** Copper, Aluminum, and White, baked enamel.
- **INCLUDES** five room-to-room speakers plus one for front door.
- **ONE** compact kitchen unit contains range hood, and music and intercom system.
- **BUILT** by the leader and originator of built-in-the-wall home music and intercom systems.
- **DISTRIBUTORS** located in principal cities—a few select territories still open.

Here's a wonderful new home-building idea to make Mrs.

Home Buyer's eyes really sparkle. A beautiful range hood with blower, light, and vent pipe ... plus a **COMPLETE ROOM-TO-ROOM MUSIC AND INTERCOM SYSTEM.** All built into *one compact unit.* Comes in choice of copper, aluminum, or white, baked enamel. Famous C & H custom unit—at a price comparable to some range hoods **ALONE!**



ONLY \$99.50
to Builders and Developers
(Installation if desired)

1620 Manufacturing St.
DALLAS, TEXAS

Manufactured by
C & H SUPPLY CO.

DOORS



Sliding doors add modern touch, save space too

Storage space can be added easily and without great expense with Glide-All sliding doors. Panels are of Masonite Duolox, a strong, non-splint, smooth material which can be finished, papered or painted to complement any room decor. Doors are engineered with positive adjustment features to assure perfect fitting of panels to out-of-square jambs, ceilings or floors. Easy to install, doors ride on track of heavy-gauge, galvanized steel for smooth, noiseless operation of roller assembly. Information on many different style Glide-All doors from Woodall Industries Inc., Dept. AB, Detroit 34, Mich.

Circle No. 7125 on reply card, p. 148



Plaster ground aluminum track for sliding doors

Washington Steel's extruded aluminum track eliminates the need for a valance because the plaster or wall board is applied right down to the bead of the track—making a neat, quick installation. Track is anti-jump, but doors can be removed for painting, cleaning, etc., without taking off the hangers, by simply unfastening the nylon door guide. Track must be installed before plastering and when used in combination with Washington's double-wheel hangers, is also recommended for dormitory or commercial installations. Washington Steel Products Inc., Dept. AB, Tacoma, Wash.

Circle No. 7126 on reply card, p. 148

MORE DOOR REMODELING IDEAS, P. 90



MENDEL DOORS

come in **6** popular woods—

and they're all
trade-marked



Mengel Doors come in *six* of the world's most beautiful cabinet woods—Gum, Gold Coast Cherry, African Mahogany, Oak, Walnut, Birch. And, for your pride and protection, all Mengel Doors (both hollow-core and solid-core) carry the striking new doweled-in-the-stile 'Mengel-Man' trade-mark—a *quality symbol all America recognizes.*

Speaking of Gum, we do some very nice things with it. At a recent show, for example, a well-known builder mistook one of our Gum doors for a much higher-priced wood—which we also make. It's pleasant to know our extra care is noticed by the right people.

Door Dept., The Mengel Co., Louisville 1, Ky.

Mengel Doors equal or exceed the requirements of Bureau of Standards specifications CS200-55



To form a moisture-vapor barrier under a concrete slab foundation, polyethylene film is laid over a bed of sand for protection against sharp objects.

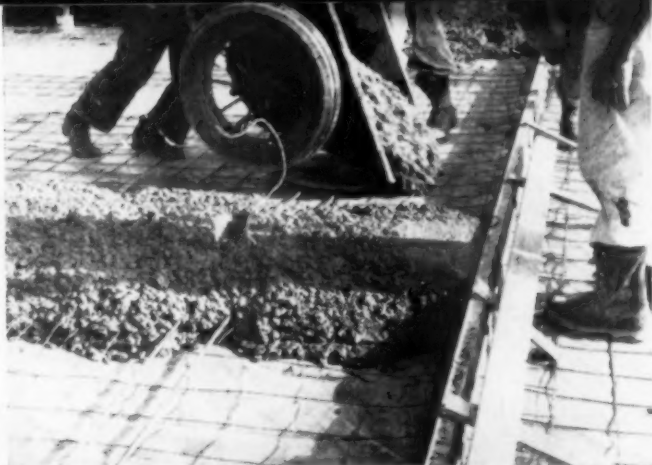

Strips of polyethylene are lapped about 6 inches, and base overlaps are secured to the wall with asphalt. Steel mesh is laid over the polyethylene, and concrete then poured in the usual way to form the slab.

How to use polyethylene film for

Lower cost, better moisture barriers

Builders have hardly begun to take advantage of film made of **BAKELITE** Brand Polyethylene for a variety of construction jobs. Polyethylene film is so very light in weight, flexible even in extreme cold, low in cost and installation time, and strong (in addition to being unaffected by lime and other chemicals) that it is ideal for waterproofing under showers, indoor planters . . . for air and dust barriers for walls and subflooring . . . for covering and protecting materials and equipment from weather out on the job . . . and other applications.

"Visqueen" film made of **BAKELITE** Polyethylene comes in rolls up to 32 ft. wide and in a variety of thicknesses. It is easily cut, stapled, or heat sealed. See your building supply dealer. Or write Dpt. NG-5



Pipes and electrical outlets protruding through holes cut in the strips are wrapped tightly in small sheets of film. They are sealed around the outlets and to the main barrier with tape before the mesh is laid down. This application was developed by **The Visking Corporation**, Terre Haute, Indiana.

*It pays
to specify
film
made of*



BAKELITE COMPANY, A Division of Union Carbide and Carbon Corporation **UCC** 30 East 42nd Street, New York 17, N. Y.
The term **BAKELITE** and the Trefoil Symbol are registered trade-marks of UCC

VENTILATING



"Pancake" ventilator takes minimum attic space

Especially designed for homes with minimum attic space . . . Diehl's "Pan-cake" Package Ventilator (Type PA). Ventilator is only eight inches deep and about 30 in. square, is set into a ceiling opening from below and protrudes two or three inches above level of attic floor. In operation, unit forces hot, stale air out of the attic, simultaneously drawing fresh air in through all open windows in the house. Inverted-rotor-designed 1/6 hp motor in fan assembly which is covered by automatic ceiling shutter. Information from Diehl Manufacturing Co., Dept. AB, Somerville, N.J.

Circle No. 7127 on reply card, p. 148

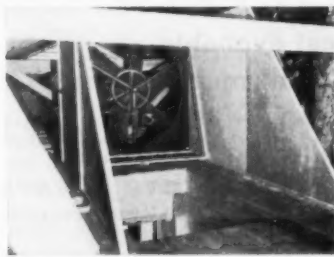

Bar-brook attic type fan offers maximum exhaust

A special fan for attic installation is marketed by Bar-Brook Co. The unit, which may be used in a vertical or a horizontal installation is usually placed over a hallway with a trap door to cover the ceiling opening when fan is not operating. Other locations, however, may be used for effective installation of the fan. Fan itself is placed facing large louvered opening in end of attic so that it will produce maximum exhaust efficiency for the entire house. More complete information from Bar-Brook Manufacturing Co., Dept. AB, Shreveport, La.

Circle No. 7129 on reply card, p. 148

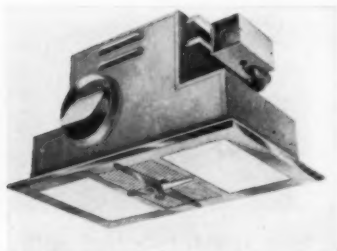

Light-ventilator to remodel bathroom ceiling

Trade-Wind's combination light-ventilator will redo a bathroom ceiling with only one installation and fixture. Unit includes a built-in back-draft damper and redesigned external conduit box. Damper is built into ventilator discharge opening and eliminates need for separate damper in duct work. Conduit box designed so cover can be removed and wiring connection made through ventilator housing, prewired at factory and equipped with two convenient knockouts. Additional information from Trade-Wind Motorfans Inc., Dept. AB, 7755 Paramount Blvd., Rivera, Calif.

Circle No. 7128 on reply card, p. 148

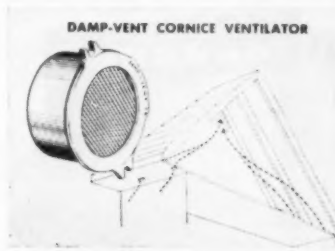

Tiny cornice ventilator will create air wash

Damp-Vent's two-inch round vent can be placed in the smallest overhang of an attic and will allow air to enter at the cornice and be exhausted through existing gable louvers or an added roof top ventilator. With installation, a thermal flow action is created causing air wash of entire roof area. Units are of sturdy cast aluminum with radial head. Tapered body gives a tight pressure fit. More information from Damp Vent Co., Attn. M. S. Field, Dept. AB, P.O. Box 203, Bettendorf, Iowa.

Circle No. 7130 on reply card, p. 148

**FOR MORE VENTILATING
REMODELING IDEAS, SEE P. 102**

**Unique
SASH
BALANCE
BACK-
BONE
of Good
Windows**

the
Twist
with changing
Pitch equalizes
the lifting power
automatically

Free your double-hung windows of the often damaging effects of friction and pressure devices which "UNBALANCED" windows need to prevent them from dropping and creeping. Unique "BALANCED" windows have absolute counterbalance, giving freedom of movement at every position of sash. Use Unique, the world's most efficient sash balance to "BALANCE" your windows. Inexpensive and quick to install.

**OVER 160,000,000
IN USE THROUGHOUT THE
WORLD**



Available thru local
Building Supply Dealers

Send for complete data today

UNIQUE BALANCE CO.
25 Bruckner Blvd., N. Y. 54, N. Y.



MuziCall

NEW AM FM FEATURE in finest available inter-com • music system

Amazingly low cost. Bound to send your home sales booming! Just watch the enthusiastic response of prospective home buyers to MuziCall features.

MuziCall PROTECTS 3 WAYS

1. *Automatic Baby Sitter* permits listening-in to nursery while occupied elsewhere in house or patio. 2. *Permanent Butler* permits talking with persons at front door from any Speaker Station. 3. *Night Watchman* relays any disturbances in house to master bedroom.

Ideal Home Inter-com

Every Station can initiate calls . . . and has individual volume control. Voice pick-up to 35 feet . . . System consists of combination AM FM Radio — Inter-Com of 5 Speaker Stations with 2 extra switches to accommodate 7 Stations (2 extra Speaker Stations available at a nominal cost).

True Fidelity Music System

model 676

throughout house — patio, too. AM FM Radio built into Master with 7 tubes and rectifier including 4 dual purpose tubes, equivalent to 12 tube performance. Phono-jack for record player.

Other Models Available

On the look-out for greater sales power? Then get the facts on MuziCall today from your nearest dealer or write direct.

MuziCall Corporation

324 SO. BEVERLY DR., BEVERLY HILLS, CALIF. • BRadshaw 2-2057

New ONAN CCK Electric Plants

**MORE
OUTPUT**
per pound of weight!

**MORE
OUTPUT**
per gallon of fuel!

**MORE
OUTPUT**
per dollar cost!

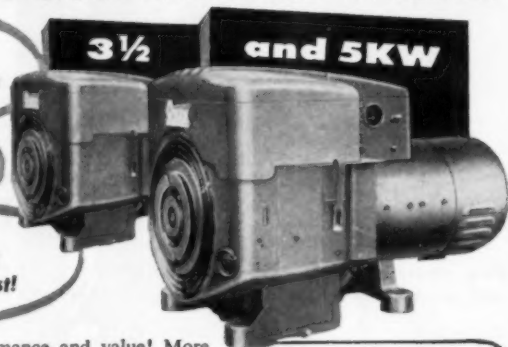

Way ahead in performance and value! More powerful, two-cylinder, air cooled Onan gasoline engines of 4-cycle, horizontally-opposed design give smooth, quieter, effortless performance. Short stroke and moderate speed cut engine wear, give longer life. Quality features include rotating Stellite-faced exhaust valves, solid Stellite valve seat inserts, full pressure lubrication. Onan's exclusive Vacu-Flo cooling system available for difficult or "buried" installations.

Completely Onan-built, with Onan gasoline engines direct-connected to Onan all-climate generators in compact, rugged units. Available in stationary, portable and standby models with a wide range of accessories.

Write for folder on all CCK models



D. W. ONAN & SONS INC.

University Avenue Southeast, Minneapolis 14, Minnesota

AMERICAN BUILDER NEW PRODUCTS

GARAGE DOORS



Garage doors do quick remodeling job

Raynor garage doors—wood, sectional type with upward-acting motion—were used to remodel the garage facilities for a small apartment building. Old door openings were reframed to coincide with standard size overhead-type doors and at the same time provide necessary clearance at top and sides. With some final trimming out the installation of Raynor sectional doors completed the transformation from old, run down, to newly valuable, remodeled property. More information from Raynor Manufacturing Co., Attn. J. Marcus Watson, Dept. AB, East River Rd., Dixon, Ill.

Circle No. 7131 on reply card, p. 148



New space, new look with basement garage added

Calder garage doors were used to finish off the addition to this house of a full garage in the basement. Company manufactures a full line of upward sectional garage doors for both residential and commercial use. All doors now feature torsion springs which require no more head room than regular extension springs and feature a neat, trouble-free installation with cable going up inside the track. More information on company's full line from Calder Manufacturing Co., Attn. Stuart Gourley, Dept. AB, 630 N. Prince St., Lancaster, Pa.

Circle No. 7132 on reply card, p. 148

FOR MORE GARAGE DOOR
REMODELING IDEAS, SEE P. 103

decorative lighting by **vir**den

This smart, new, pull-down fixture has reel concealed

Here is one of the brightest, brand-new ideas in the long history of home lighting! Virden has concealed the reel in the canopy.

Hanging 33 inches from the ceiling, the fixture spreads its beams over a wide area and can be pulled down instantly and easily to any desired length up to 53 inches, concentrating its beams in a smaller area.

Its generous 18-inch hood comes in a variety of finishes—brass, copper, pink, white or black. Three 60-watt lamps, shielded by a frosted glass diffuser, provide soft but efficient illumination.

The thin, strong cable—artfully hidden by the smart, coiled, black cord—disappears into the decorative ceiling canopy as the fixture is raised.

Shown here is but one of the many styles of Virden reel-concealed pull-down fixtures—all designed to blend skillfully with countless varieties of room arrangements and furnishings.

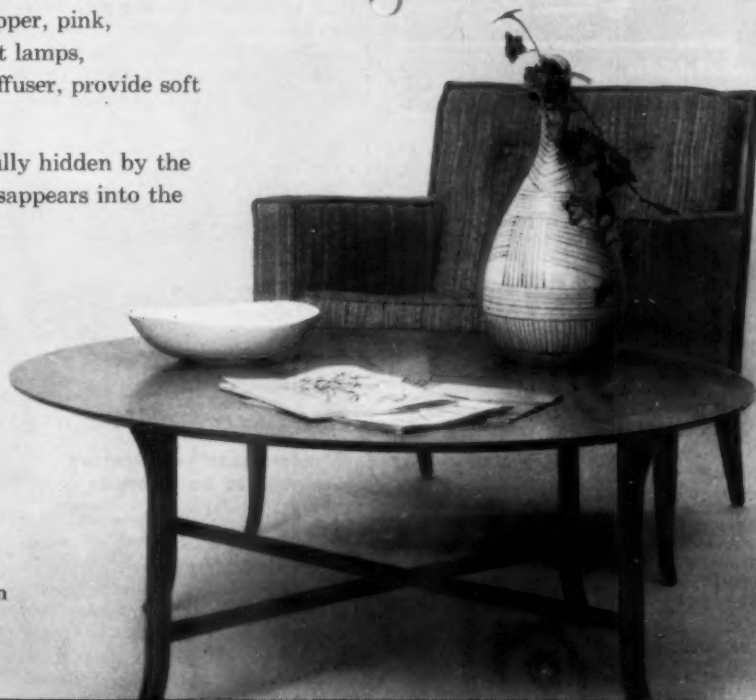

Write today for Catalog No. 56, showing in full color all of the popular Virden styles, including the Virden line of pull-down fixtures.

Member of American Home Lighting Institute



John C. Virden Co., Dept. AB-7, 6103 Longfellow Ave., Cleveland 3, Ohio

Please send me Catalog No. 56.

Name _____

Address _____

City _____ Zone _____ State _____

Occupation _____

SEE THE
Sasgen

LIFTAMATIC
at your
dealer's...

ALUMINUM
OR STEEL
MODELS

Lifts up to
1200-lb. load
to 110 ft.

Handles bulk or
unitized loads

Gas or Electric
Powered

OR WRITE
DIRECT
FOR
LATEST
LITERATURE

Sasgen DERRICK COMPANY

3103 GRAND AVENUE • CHICAGO 22, ILLINOIS

ONLY Winco®
Portable Electric Power

Gives You the Exclusive New

CONSERV-er

IDLING CONTROL
✓ Extends Engine Life
✓ Reduces Fuel Consumption
✓ Lowers Maintenance Cost

CONSERV-er Idling Control—a flick of the lever reduces engine to idling speed when power is not needed. Conserves fuel, extends engine life—cuts service and operating costs.

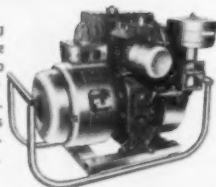

205B14S2D-1M2—New 2500 watt Direct Drive contractor model, 115 volts, 60 cycles, A.C. Carrying cradle optional—Specify Kit #23410. Speedy-Shift dolly available as optional equipment—Specify Kit #2305.

Please send me full information about Winco Portable Electric Power with exclusive new CONSERV-er.

WINCHARGER CORPORATION
SIoux CITY, IOWA

Name.....

Address.....

City.....State.....

WINCHARGER CORPORATION
SIoux CITY, IOWA
Subsidiary of Zenith Radio Corporation

AMERICAN BUILDER NEW PRODUCTS

HEATING

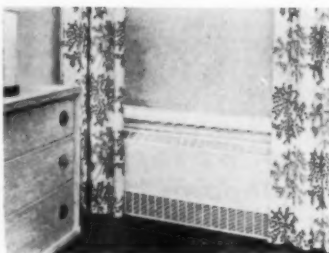

Add new heating look with Trane convactor

An old room can be given a new look by replacing unsightly radiators with a Trane convactor. Originally "tailor-made" to fit each job, the Trane convactor has evolved into a line of standard models and sizes suitable for any job. Universal heating element is applicable to any hot water or two-pipe heating system. Trane convactor cabinets may be installed free-standing against the wall or recessed into the wall. Cabinet lines lend themselves to modern or traditional home furnishing. Trane Company, Attn. Lloyd Herbstreith, Dept. AB, La Crosse, Wisc.

Circle No. 7133 on reply card, p. 148



Prefab fireplace can be added to any room

Uni-bilt's pre-fabricated fireplace, a full-size, wood-burning unit complete with its own chimney, can be added to almost any room in the home without major structural changes, masonry work or extensive redecoration. In most homes, the fireplace—a high temperature ceramic firebox supported on a cantilevered hearth—is quickly attached to an existing wall, the chimney run through the ceiling and roof, and the chimney housing flashed into place. Whole operation, according to the maker, should take four to six man-hours. More information from Uni-bilt Div., Vega Industries Inc., Dept. AB, Syracuse 5, N.Y.

Circle No. 7135 on reply card, p. 148

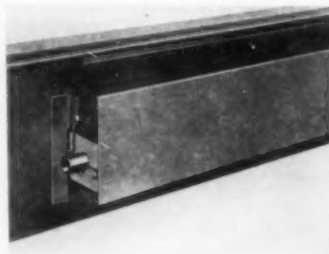

"Perimaheat" convectors replace old baseboards

One way to install a new perimeter heating system is with Young's "Perimaheat" baseboard convactor system. Displacing ordinary wooden baseboards, system provides hot water heat all around the room, eliminating cold spots and drafts along the floor or along outside walls. Non-ferrous, high capacity heating element insures fast transmission of heat from boiler to rooms. Shown above with optional damper and other construction details exposed. "Perimaheat" convectors are assembled at factory, easy to install. Information from Young Radiator Company, Attn. A. E. Slaasted, Dept. AB, Racine, Wisc.

Circle No. 7134 on reply card, p. 148

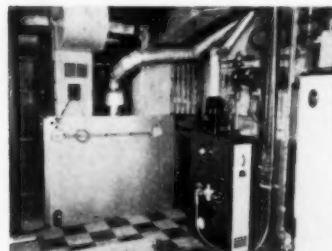

Circulated water system added to home

Bell & Gossett added a circulated water system to remodel the heating capacity of this house. A new B & G boiler was added alongside the existing hot air furnace. With the circulated water system, the basement (which included a remodeled recreation room) was properly heated and lost its cold, damp feeling. Each small B & G pump is controlled by its own thermostat, thus obtaining a maximum of control. More information from Bell & Gossett Co., Attn. H. R. Henke, Dept. AB, Morton Grove, Ill.

Circle No. 7136 on reply card, p. 148

ALL EYES ARE ON WESLOCK NEW **FASTER INSTALLATION**

For Sunray®, Concave or Standard Knob Designs

New Weslock engineering
has produced the fastest,
easiest-to-install
residential lockset on
the market today!



NEW...snap-on knob catch.
Just slide knob on spindle,
and it snaps securely in
place.

NEW...bayonet slots permit
instant, accurate alignment
of back plate to lock casing.

NEW...factory pre-set
machine screws speed up
assembly time.

✓
*Faster Installation
means more profit*



WESTERN LOCK MFG. CO.

Manufacturers of Weslock Residential Locksets and Building Hardware

GENERAL OFFICES: 211 NORTH MADISON AVENUE, LOS ANGELES 4, CALIFORNIA • FACTORY: HUNTINGTON PARK, CALIFORNIA

Three men erect **66** tied arches in only **85** man hours!

No special equipment or skilled labor used!

"We erected 66 Rilco Laminated Arches with three unskilled men—including arch assembly—in only 85 total man hours on this 46x130' IGA Food-liner in Weatherford, Oklahoma . . . and at only 25% of what we figured steel erection would have cost!" That's the statement by Johnny Klaassen, Weatherford contractor. "They're the best I've ever seen! We found Rilco Laminated Wood Tied Arches are of fine quality and workmanship—strong, rigid and attractive. And no trouble at all to achieve an even roof and ceiling.

"The ease of erecting arches saved time. I used only common labor under the supervision of a carpenter—no scaffolding or cranes."

Rilco glued laminated arches are prefabricated, pre-cut and drilled for hardware furnished. Placed two feet on centers, they offer true level framing for roof and ceiling construction. Write for free data on tied arches.

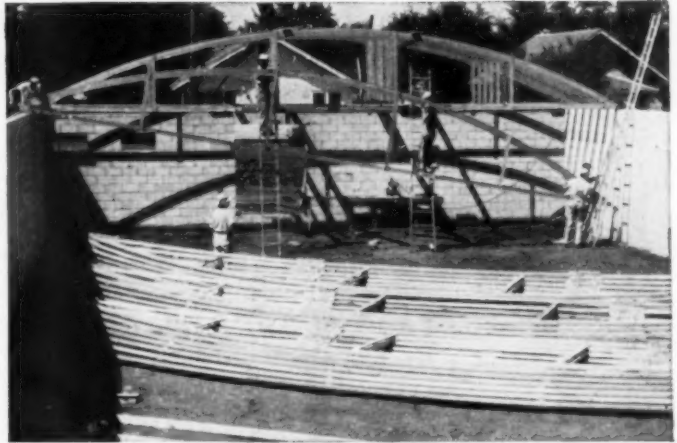

RILCO LAMINATED PRODUCTS, INC.

2511 FIRST NATIONAL BANK BLDG., ST. PAUL 1, MINN.
District offices: Wilkes Barre, Pa., Ft. Wayne, Ind., Tacoma, Wash.

FREE!

tool CATALOG for the trowel TRADES

No strings attached. If you are in the building trades, we want you to have a FREE copy of this "encyclopedia of tools." Fully illustrated, it's 70 pages long and describes more than 1000 tools, many so uncommon only one man in a hundred might need them. Every tool you'll ever need to earn a living is here. You don't have to buy anything to get our catalog. But when you do want tools, we have them. Get your copy now.



***** MAIL THIS COUPON TODAY! *****
 * Goldblatt Tool Company, Dept. 5-7
 * 1012 Walnut Street
 * Kansas City 8, Missouri
 * Please send me FREE your new Goldblatt Tool Catalog.
 * Name.....
 * Address.....
 * City..... State.....

CINCINNATI ORNAMENTAL WROUGHT IRON PORCH COLUMNS AND RAILINGS

Corner or Single Porch Columns available in eighteen designs, 10" wide on centers or smaller, in any height desired. Also Ornamental Brackets, Chimney Ornaments, Area Gratings, Wire & Iron Window Guards, and Flush-Type Cellar Doors.

Interior and Exterior Railings are made in a variety of styles, with a choice of ornaments if desired.

Send for descriptive leaflet and prices, sending measurements of your requirements. Also inquire about Cincinnati Ornamental Wrought Iron Shutters.

CINCINNATI IRON FENCE CO. INCORPORATED

2107 FLORENCE AVE. CINCINNATI 6, OHIO

... "better than any transit!"

"When it comes to accuracy, the Levelall is better than any transit," writes Mr. Richard S. Otto. LEVELALL is a 75' transparent plastic tube with shut-off valves, mounting brackets and filled with a special anti-freeze liquid... a precision leveling instrument for only \$12.95. With it, one man can do the work of two men and a transit.

Send today for your FREE copy of "On the Level," a booklet that tells and shows how to use the Levelall.

LEVELALL, 83G Webster St., Rockland, Mass.

Please send free booklet, "On the Level." Mail me 75' Deluxe LEVELALL @ \$12.95 Regular 50' model at \$9.95 Ship postpaid full price enclosed.
 Ship C.O.D.

Name.....
 Street.....
 City..... Zone..... State.....

A TRUE VAPOR SEAL MUST CONTAIN THESE FEATURES . . .

Check your present vapor barrier material for these quality standards . . .

- ✓ Vapor permeance of only .0066 grains of water per square foot per hour.
- ✓ Strong enough to resist rupturing and tearing during the pouring of aggregate and under the trundling of wheelbarrows.
- ✓ Permanently installed in a minimum of time to provide a monolithic barrier that will expand and contract with the slab above without breaking the seal.
- ✓ Resistant to rot, mold and termites.
- ✓ Provides positive protection against moisture in all slab-on-grade, crawl space and basement type installations.

Only

SEALTIGHT

Premoulded Membrane

TRADEMARK

HAS THEM ALL!

Be sure that the vapor seal material you're using or specifying meets these Sealtight standards of quality . . . it's the one sure way to provide positive protection against destructive moisture.

We sincerely advise and invite your comparison of "Premoulded Membrane" against all other vapor seal products . . . we're sure that once you do, you'll also agree, that there's only one true vapor seal on the market . . . Sealtight "Premoulded Membrane."

ARCHITECTS, BUILDERS, HOMEOWNERS

Remember the time to "eliminate" destructive moisture and vapor is in the original construction, with the use of Sealtight Premoulded Membrane and Corktite perimeter insulation . . . all other methods are merely temporary "stop-gaps".
WRITE TODAY FOR COMPLETE INFORMATION.

"Guardian of the Home"

MANUFACTURED BY . . .

W. R. MEADOWS, inc.

8 KIMBALL ST. • ELGIN, ILLINOIS

JULY 1956

NEW WALL TILE DESIGN *eliminates* EXPENSIVE SURFACE PREPARATION

In remodeling projects, you can now plan to provide new, beautifully tiled walls over badly marred or aged surfaces **without expensive surface preparation**. Here's how: apply sheet rock over the old surface, then tile the sheet rock with Crown Metal Wall Tile.

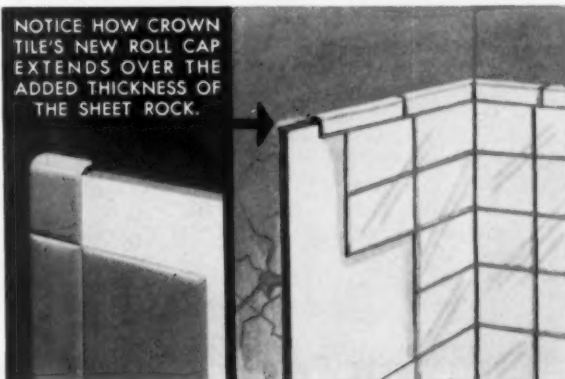

NOTICE HOW CROWN TILE'S NEW ROLL CAP EXTENDS OVER THE ADDED THICKNESS OF THE SHEET ROCK.

This method is now so workable because of Crown Tile's new Roll Cap design. The sketch above shows how this new design compensates for the extra thickness of the sheet rock, providing a neat, all-tile appearance. The cap covers the top edge of the sheet rock: it's then an easy matter to complete the tile installation in the usual manner. The result is a new, **inexpensive** surface of lasting, low-maintenance beauty with a minimum of material and labor costs for you.

We'll be glad to send you complete information on this profit-making remodeling idea without obligation, as well as information on **Crown Steel, Aluminum, Coppertone, Stainless Steel Wall Tile**. Use the coupon below.

CROWN TILE CORPORATION

P. O. Box 564, Massillon, Ohio

Gentlemen: Please send me details on Crown Tile's remodeling plan.

Your name _____

Company name _____

Dealer _____ Wholesaler _____ Contractor _____ Builder _____

Address _____

City _____ State _____

179

STANLEY

Electric Tools



One motor... two tools hundreds of applications

It's the H188 Router-Plane Kit!

Here in one compact kit are two tools that do hundreds of woodworking jobs. For economy of space and cost, both tools use the same heavy duty, Stanley-made motor. 16" jointer plane and Stanley H45 Router in carrying case with motor, guide, cutter, bit, arbor, wrench, and vials for storing bits and cutters.



The router is Stanley's H45, a smooth cutting tool at 22,000 rpm. Does dovetailing, rabbeting, mortising, trim cuts of all kinds.

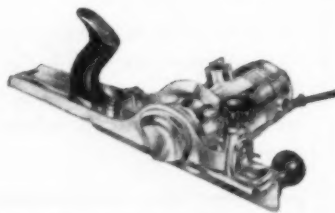

The plane is Stanley's new H58, a 16" jointer plane. Cuts door edges up to $2\frac{1}{16}$ " wide. Depth adjustment—0" to $\frac{3}{32}$ ".

Look for H188 Router-Plane Kit at the Stanley Electric Tool distributor near you. For further details write Stanley Electric Tools, Division of The Stanley Works, 107 Myrtle St., New Britain, Conn.

STANLEY

AMERICAN BUILDER NEW PRODUCTS

HEATING



Radiant Glasheaters in recessed, surface models

Continental's radiant glassheaters offer an electric heating system free of fire hazards, noise, odors and dirt. Glasheat's heat zone method propels healthy infra-red rays across the room in 160 degree originating angles. Temperature is zone-controlled with accurate wall-type thermostats. Glasheat panels will not wear out, can be recessed in new or old walls or come in surface models. Surface models require only a 4"x4" junction box space. More information on both models from Continental Radiant Glass Heating Corp., Dept. AB, 1 E. 35th St., New York City, N.Y.

Circle No. 7137 on reply card, p. 148



Wall-insert Heataire fits into old walls

Auxiliary heating for older homes as well as new ones can be easily accomplished with Markel's Wall Radiant Heataires which offer both infra-red rays plus fan-forced heated air. Series 240 (here illustrated) come with either built-in thermostat or manual control, range from models of 1000 to 1500 watts, have chromium plated reflectors, nu-chrome or ivory enamel finish. Front is $17\frac{3}{8}$ " high, $12\frac{5}{8}$ " wide; box has depth of $3\frac{3}{4}$ ". Box is easily installed like an ordinary outlet box. Heataire front and mechanism come already assembled as one unit to be attached to box. Markel Electric Products Inc., Heataire Div., Dept. AB, Buffalo 3, N.Y.

Circle No. 7138 on reply card, p. 148

FOR MORE HEATING
REMODELING IDEAS, SEE P. 76



**EVERYONE POINTS
WITH PRIDE TO WEISER LOCKS**

Ever notice how people like to boast a little and point with pride to something that is just a little better? Well, that's the way it is with Weiser Locks.

Dealers like them because of the customer satisfaction which continues after every sale. Builders like them because they know that besides being easy

to install, Weiser Locks are going to deliver years of guaranteed trouble-free performance. And homeowners like them because of their beauty and rich appearance which add dollars to the value of their home.

Yes, everyone points with pride to Weiser Locks.

WEISER LOCKS

WEISER COMPANY • SOUTH GATE, CALIFORNIA



Another big addition to the Gold Bond Line!

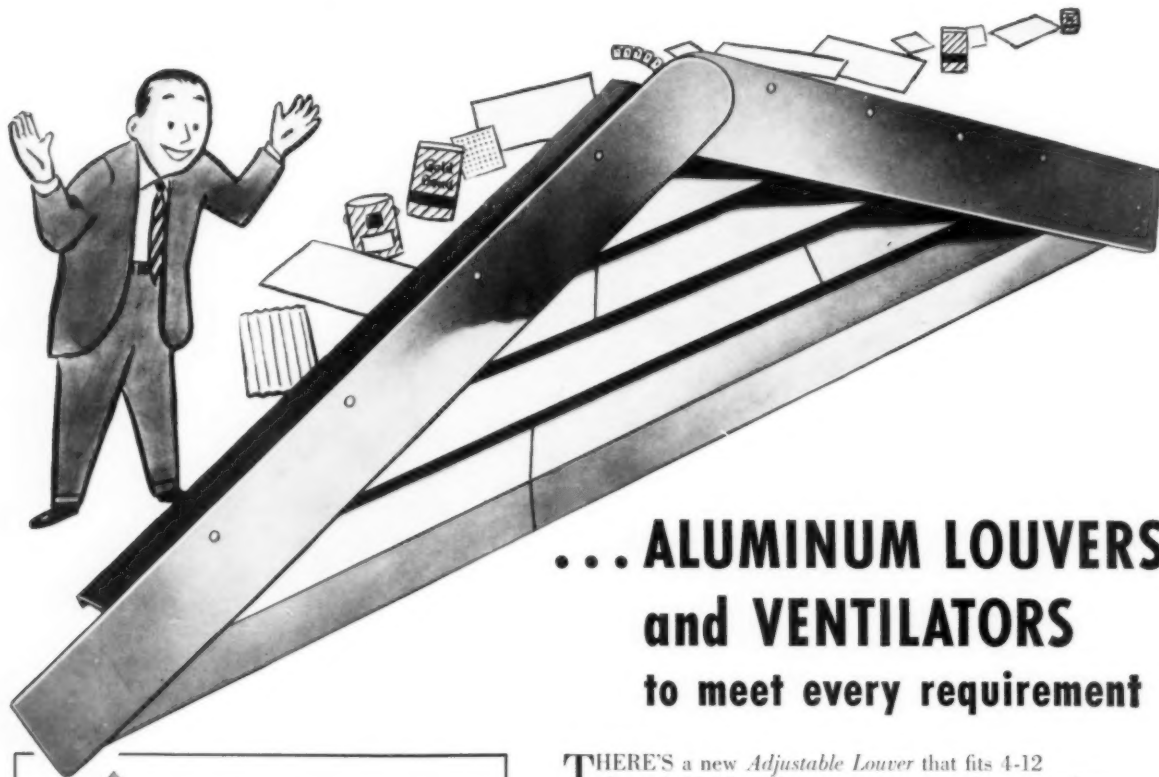

... ALUMINUM LOUVERS and VENTILATORS to meet every requirement

ADJUSTABLE LOUVERS—7 sizes up to 92" base, from 4 to 8 vanes.

FIXED LOUVERS—4-12 pitch, 5 sizes from 7" to 12" base. 5-12 pitch, 4 sizes from 38" to 67" base.

FLUSH AND RECESSED LOUVERS—Flush—11 sizes up to 30" x 24". Recessed—7 sizes up to 24" x 30".

ROOF VENTILATORS—3 sizes. Fits shingled roofs of any pitch.

WALL AND UNDER EAVE VENTILATORS—For under eaves, cornices or soffits.

FOUNDATION VENTILATORS—fit standard 16" x 8" block opening.

All louvers and ventilators furnished with FHA-required 8-mesh aluminum screen and formed from .025" aluminum except Foundation Ventilators which are die-cast aluminum.

THERE'S a new *Adjustable Louver* that fits 4-12 through 12-12 pitch—a greater range than any other adjustable louver—and gives a large free area at every pitch. This is an integral unit—can't come apart—designed to simplify gable peak ventilation. There's a *Fixed Louver*, ideal for use with attic fans, with an exclusive design that assures permanent and rattle-free installation.

The easily-installed *Flush Flange Type* is adaptable to frame, brick or veneer walls. For use in new construction or re-siding jobs, the *Recessed Flange Type* needs no wall framing in installation.

Gold Bond *Roof Ventilators*, designed to fit shingled roofs of any pitch, are flanged, baffled and screened to make installation easy, weathertight and insectproof. A series of *Wall and Under Eave Ventilators* is designed to supplement ventilation in roof or attic wall.

The *Foundation Ventilator*, made with or without an adjustable damper, has a die-cast frame and grill of strong, non-porous aluminum alloy that's acid-resistant and immune to electrolysis. It can replace concrete block in foundations or can be attached to ends of wood joists when poured-concrete foundations are used.

For the full story on Gold Bond's complete line of louvers, get the Gold Bond Louver folder today. Write National Gypsum Company, Buffalo 2, New York.

ALUMINUM LOUVERS AND VENTILATORS

NATIONAL GYPSUM COMPANY

Gold Bond
BUILDING PRODUCTS

This new Prefabricated FIREPLACE

installs in 4 to 6 man-hours
...no masonry required!



1 Frame is fastened directly to studs with lag screws.

2 Hearth & firebox are formed of interlocking ceramic sections.

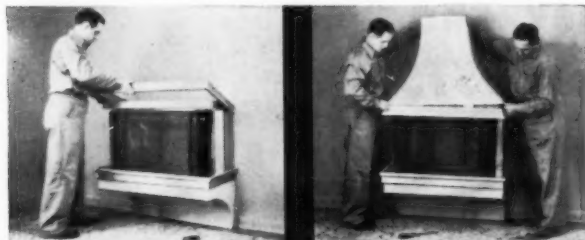

3 Stainless steel trim and flexible fire screen are easily installed.

4 Fireplace hood sets on hood support channel—fits tight to wall.



5 Interior chimney sections are extended through ceiling and roof.

6 Attractive exterior chimney housing completes the installation.

MAIL COUPON TODAY!...find out how easy it is to add the sales appeal of the Uni-bilt Fireplace to YOUR homes.

Add the sales appeal of this real wood-burning fireplace to your homes.

The new Uni-bilt Fireplace needs no costly masonry, no foundation, no mantel or facing. It comes complete with its own chimney and can be installed by semi-skilled workmen in 4 to 6 man-hours.

The Uni-bilt Fireplace is approved by Underwriters' Laboratories for installation directly against any wall, floor, ceiling or roof material. Installed quickly and economically in new or existing homes, it blends with any style architecture; can be painted to harmonize with any color scheme.

Uni-bilt
FIREPLACE

- Vega Industries, Inc., Uni-bilt Division
- 717 Glen Ave., Syracuse 5, N.Y.
- Send complete information on the new Uni-bilt Fireplace.
- Name.....
- Company.....
- Street.....
- City.....Zone.....State.....
- I am a:.....builder.....architect.....dealer

**PUT OUR EXPERIENCE
behind YOUR home
AIR CONDITIONING**



Many builders, through lack of personal experience with year-around air conditioning, hesitate to put it in their homes—but *not those who specify Majestic*. They know the full weight of Majestic's many years of "home comfort" experience stands firmly behind their ultra-modern 1956 units. In remodeling or in new construction, the contractor expects and gets all the benefits of Majestic's research and engineering.

Majestic 1956 Line IS COMPLETE

Whatever system you want—2, 3, or 5 ton self-contained water-cooled units or remote air-cooled models, in matching twin units or for add-on installations—Majestic has it in the 1956 line. For only a very few dollars, a Majestic Furnace installation can be equipped with a remote-system evaporator cabinet, ready for "the works" whenever the home owner decides on all-season air conditioning.

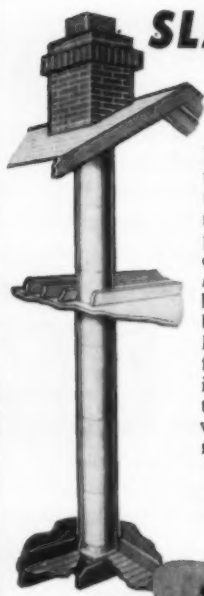

**SLASH Chimney and
Fireplace COSTS**

Majestic also makes the revolutionary metal Thulman Chimney that *cuts erection costs* to a minimum, and Thulman Fireplace, the complete fireplace and chimney that *needs no masonry*. Both have simulated red-brick top housings. Both are U.L.-listed for *zero clearance* installation in homes to two-stories high, with or without basement.

**Call your nearest
Majestic Dealer,
or write today**



The **Majestic** Co., Inc.

433 Erie Street

Huntington, Indiana

AMERICAN BUILDER NEW PRODUCTS

BATHROOMS

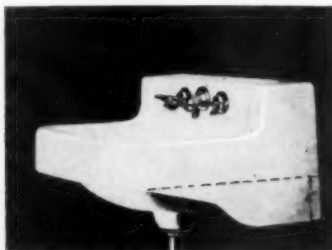

**New shelf lavatory
hangs from wall**

A wall-hanging shelf lavatory should prove of interest to builders. Called the Juneau, its chief feature is its integral wall support giving four additional inches of wall-bearing surface. Two screw holes are on the underside of the lavatory for anchoring securely to wall. It measures 19"x17" and is made of vitreous china. The 4½" shelf is unobstructed, has fittings mounted over the basin, and a 4" back protects the wall against splashing. More information may be obtained from Kohler Co., Dept. AB, Kohler, Wis.

Circle No. 7139 on reply card, p. 148

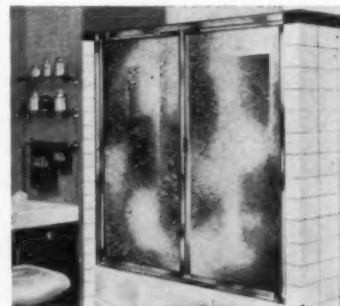

**New look, privacy with
this tub enclosure**

A completely modern bathroom, plus added enjoyment of privacy when this bathtub enclosure is added to the bath. Beauti-dor tub enclosure is of double-thick and extra-heavy glass, surrounded by specially heat-treated aluminum to give maximum tensile strength. Panels glide from either end on double overhead ball bearing rollers. Enclosures are custom made to fit all 3½ to 5½ ft. recessed wall to wall tubs. Information from Shower Enclosures Inc., Dept. AB, 4723 N. Pulaski Road, Chicago 30, Ill.

Circle No. 7140 on reply card, p. 148

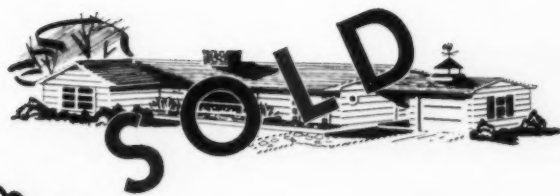

by MORGAN · WIGHTMAN Climax Fans & Bath Accessories



Mr. Builder: Put the "SOLD" sign on your new home or add eye-catching appeal to your remodeling jobs with one simple, and *inexpensive*, operation... just specify Climax Fans and Bathroom Accessories from Morgan-Wightman Supply Co.

Whatever your needs may be in Bathroom Cabinets, Mirrors and Accessories, Access Doors or Ventilating Fans (*Climax*, of course) . . . be sure and let Morgan-Wightman Supply Company furnish your needs with *better products for building*.

JUST OFF THE PRESS! Our gigantic NEW free catalog! 100 pages filled with everything you need in building supply products. Morgan-Wightman is now, more than ever, truly the "one-stop warehouse" for all your building supplies. Send for your copy today!



SEND NOW FOR OUR LATEST CATALOG
No Cost—No Obligation

Morgan-Wightman Supply Co., Dept. 25
1541 Salzman Ave., St. Louis 20, Mo.
Please rush me your new free catalog

NAME _____
COMPANY _____
STREET ADDRESS _____
CITY _____ ZONE _____ STATE _____

MORGAN-WIGHTMAN
St. Louis 20, Mo.

NEW Most Powerful One Man Chain Saw You Can Own



7 horsepower
29 pounds

HOMELITE

A DIVISION OF TEXTRON, INCORPORATED
507 RIVERDALE AVENUE, PORT CHESTER, NEW YORK
MANUFACTURERS OF CARRYABLE PUMPS • GENERATORS • BLOWERS • CHAIN SAWS

In Canada: Terry Machinery Co., Ltd.

Toronto • Montreal • Vancouver • Ottawa • Edmonton • Mancton

7-29

**Complete Line
of Chain Saws
for Every
Cutting Job**



MODEL 17 — An all purpose saw that brings down trees up to 4 feet in diameter. Available with special brush cutting and clearing attachments for complete versatility 3.5 horsepower 22 lbs.



MODEL 5-20 — All the versatility of the 17 with added power, lighter weight. 5 full horsepower — 20 lbs. Brings down trees up to 6 feet in diameter.



MODEL EZ — Lightest, most powerful direct drive chain saw ever developed. Only 19 pounds, full 5 horsepower. Brings down trees up to 3 feet in diameter.

CHOOSE
from a full line of
HOMELITE
Carryable
Construction
Equipment

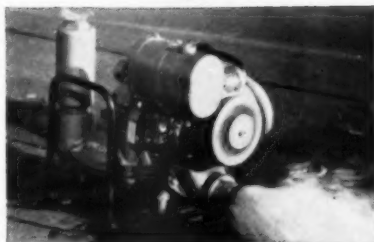

**SELF-PRIMING CENTRIFUGAL AND
DIAPHRAGM PUMPS**

Sizes: 1½" to 3" — capacities to 15,000
g.p.h. for dewatering and water supply.

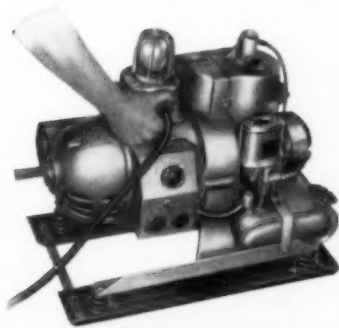

**ELECTRIC GENERATOR SETS FOR
TOOLS AND LIGHTS**

Complete range of sizes and voltages
up to 5,000 watts.



**LIGHTWEIGHT POWERFUL ONE-MAN
CHAIN SAWS**

Complete line of saws with clearing and
brushcutter attachments for every
woodcutting job.

HOMELITE

A DIVISION OF TEXTRON, INCORPORATED
PORT CHESTER, N. Y.

JULY 1956

AMERICAN BUILDER NEW PRODUCTS

BATHROOMS



**Counter lavatory features
dual top mounting**

This counter lavatory can be installed for flush back mounting with bar-type frames, or can be built in three sides with U-type frame. Features include an anti-splash rim, concealed front overflow, two integral soap dishes. Lavatory is made of vitreous china, and available in white and six colors. Size: 20"x18". Model is Cynthia E-3308-C. More information available from Eljer Div. of the Murray Corp. of America, Dept. AB, Three Gateway Center, Pittsburgh, Pa.

Circle No. 7141 on reply card, p. 148

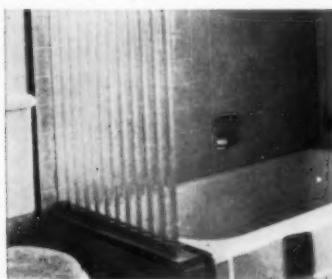

**Modern look in bathroom
with corrugated glass**

Shown: a 27-in. wide light of Pennsylvania Corrugated Glass installed on an end-of-tube tile "arm." A stainless steel frame anchored to the "arm" holds the glass panel. The corrugated glass is secured to a similar ceiling frame. No frame on the tile side of the tub is necessary for the glass panel fits tight to the tub. Used this way, corrugated glass protects against water spray damage to nearby bathroom fixtures. The 3/8" thickness of the glass adds to its safety value. In white or ac-tinic. Pennsylvania Wire Glass Co., Dept. AB, 1612 Market Street, Philadelphia 3, Pa.

Circle No. 7142 on reply card, p. 148



Homes constructed by
Palmer & Krueger, Kenosha, Wisconsin

**Magnesium Forms
Speed Work on
Kenosha Jobs**

Jim Krueger of Palmer & Krueger, Kenosha, Wisconsin says that after several days rain which left the ground muddy and substantial water in the excavation, his men were still able to strip Symons Magnesium Frame Plywood Forms from one job, load them on a truck, and take them to another job at the other end of town, unload them and set them up ready for pouring by 1:30 P.M.

ACTUAL SET-UP TIME—2 HOURS

The foundation was 30' x 42' with window bucks and brick ledge. Walls were 7 feet high and 10 inches thick. Jim Krueger credits the fast set-up to Symons Lightweight Magnesium Frame Plywood Forms and his crew of 4 experienced men.

90 USES PER SET PER YEAR

Palmer & Krueger has two sets of Symons Magnesium Frame Plywood Forms. They pour an average of 6 foundations per week. Before each use, the forms are oiled with a horse hair window brush that has a six foot handle. Forms set up one day are always stripped the following morning. Time required for stripping is approximately one hour.

FREE ENGINEERING SERVICE

Upon receipt of your plans our engineering staff, which is experienced with all types of forming, will furnish complete form layouts and job cost sheets on your form work—at no charge or obligation. Our salesmen are always available for consultation and to give advice on form erection, pouring and stripping methods. Builders throughout the country use this service to their benefit and profit.

Rentals—Symons Forms, Shores and Column Clamps may be rented with purchase option, all rentals to apply on purchase price.



SYMONS CLAMP & MFG., CO.
4261 Diversey Avenue, Chicago 39, Illinois, Dept. C-6

Please send complete information on Symons Plywood Forms in Magnesium Frames.

Name _____
Firm _____
Address _____
City _____ Zone _____ State _____

**FASTEN
TO CONCRETE
OR STEEL
THE
NEW
WAY**

**WITH
Shure-Set**

PATENTS PENDING

—THE HAMMER-IN FASTENING METHOD

WOOD TO MASONRY

shelves
paneling
partitions

Where nails fail and Ramset® is not required, SHURE-SET fills the bill. It's the in-between tool that handles countless jobs better than concrete nails or drilling.

WOOD TO STEEL

furring strips
signboards
panel boards

Here's a new fastening tool, essential to everyone who works with concrete or steel! Just pick up a hammer and your SHURE-SET KIT and you can fasten into cement block, masonry, 1/4" steel, mortar joints and other hard materials.

STEEL TO STEEL

wire mesh
window guards
pipe straps

SHURE-SET supports and guides the fastener straight and true with pin-point accuracy. No bending, buckling, bouncing—fasteners sink into hard materials as if by magic!

STEEL TO CONCRETE

conduit
clips
downspouts

Uses no outside power; just makes your hammer power more effective. It's a "must" tool for every carpenter, electrician, plumber or builder of any kind. Especially valuable where Ramset may be too powerful.

Ask your supplier. SHURE-SET gives you a real advantage over old-style methods. Get the jump on your competition. Write now for full details.

COMPLETE KIT
contains every-
thing you need



Ramset is the original powder-actuated method for heavy-duty fastening.

Shure-Set ... BY THE MAKERS OF Ramset®

RAMSET FASTENING SYSTEM - WINCHESTER - WESTERN DIVISION

OLIN MATHIESON CHEMICAL CORPORATION

12113-G BEREA ROAD • CLEVELAND 11, OHIO

AMERICAN BUILDER NEW PRODUCTS

BATHROOMS



Plastic wall tile adds shine to bathroom

Artcrest Plastics offers two new plastic wall tiles for remodeling the bathroom walls. Both the new Glo-Sheen tile and the new Irrescent tile will re-do the old bathroom in a durable, shiny-textured finish. Both tiles are easy to clean, keep their good looks through wear, will reduce maintenance problems, according to the manufacturer. Tiles also come in a selection of patterns for designs, as well as molded corners and trims. From Artcrest Plastics Co. Inc., Attn. John P. Hughes, Dept. AB, 255 W. 79th St., Chicago 20, Ill.

Circle No. 7143 on reply card, p. 148



"Daylite" shower stall has precast receptor

Glass Shower Door's No. 2000 "Daylite" unit is designed to fit in any corner 36" x 36", will answer the second bath problem where space is at premium. Unit is shipped complete with precast receptor and complete enclosure with all necessary parts for installation. Lists at \$249 from company or sectional distributors. Information from M. A. Grier, Dept. AB, Glass Shower Door Co. Inc., 105 W. Wacker Drive, Chicago, Ill.

Circle No. 7144 on reply card, p. 148

**FOR MORE BATHROOM
REMODELING IDEAS, SEE P. 92**

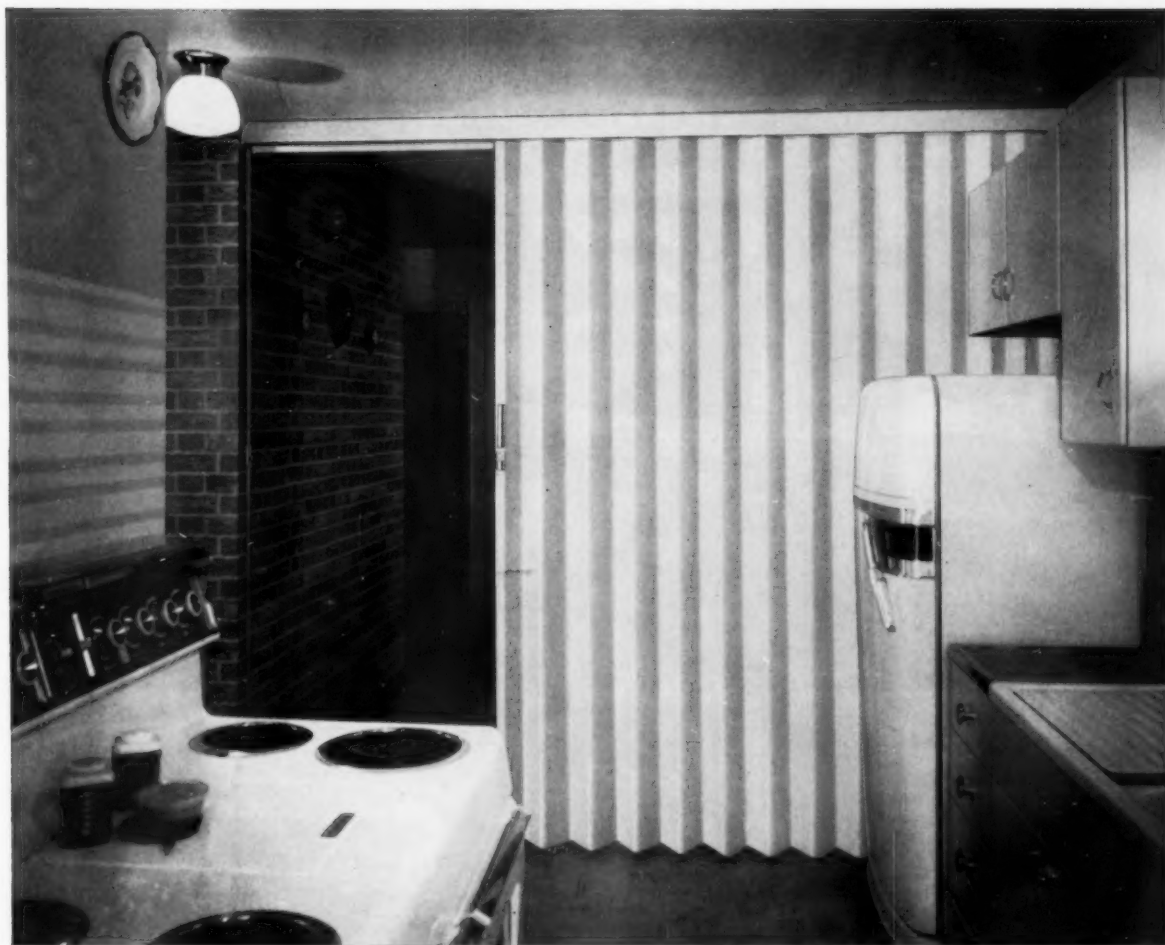

Builder Donald W. Johnston uses FOLDOOR as movable partition in typical Imperial Home, Peoria, Ill.

Imperial Homes Choose Foldoor!

For making homes *sell* faster, you can't beat FOLDOOR by Holcomb & Hoke. These are the folding doors that operate easiest—with 61% less hinge friction. That look better—with exclusive cornice for a "finished" look. And that are sturdy—as proved in thousands of installations. That's why Donald W. Johnston chose FOLDOOR by Holcomb & Hoke for his entire Imperial Homes project at Peoria, Ill. That's why, whether you're building one home or 1,000 in 1956, it will pay you to investigate Holcomb & Hoke's line of folding doors. Remember, *only* Holcomb & Hoke makes a *complete* fabric-covered line. Three price ranges for every home . . . a deal for everybody—a deal for you!

INSTALLING DISTRIBUTORS IN ALL PRINCIPAL CITIES
In Canada: FOLDOOR OF CANADA, Montreal 26, Quebec



HOLCOMB & HOKE MFG. CO., INC.
1545 Van Buren St.
Indianapolis, Indiana

Please send full details on FOLDOOR

NAME _____

ADDRESS _____

CITY _____ STATE _____

L

LOOKING for *Thorough* HOME COOKING VENTILATION?



Vent-A-Hood
HAS IT

- ★ In Capacity!
- ★ In Design!
- ★ In Quality!

Vent-A-Hood
Has
Exactly What
YOU Want!



Vent-A-Hood
Produces
Every Style
and Trim



Vent-A-Hood
Offers
All Colors
and Metallics

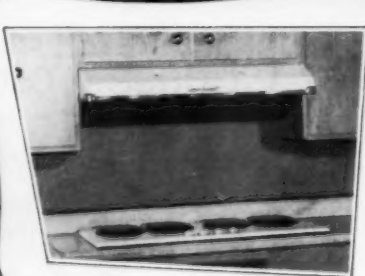

BE SURE!

You just can't go wrong with a Vent-A-Hood! It's thorough! Factory trained cooking ventilation specialists serve every section of the country to help you in the choice of the most practical...the most attractive cooking ventilation equipment for any kitchen arrangement. You'll accomplish more in every way when you choose Vent-A-Hood for your home cooking ventilation needs.

Depend upon your local Vent-A-Hood specialist for the cooking ventilation results you desire...a half million already have.

Please send more information about Vent-A-Hood Cooking Ventilation

Name _____

Address _____

City _____ State _____



1903 Plantation Rd. • Dallas, Texas

HOME COOKING VENTILATION SPECIALISTS

AMERICAN BUILDER NEW PRODUCTS

KITCHENS



Tile look for kitchen with vinyl wall covering

A real tile look for old kitchen walls can be obtained by use of Sandran Wall Covering. In a wall tile design, the colors and pattern are underlaid beneath pure, tough vinyl and are guaranteed not to wash or wear away. Vinyl surface is impervious to grease and soil, wipes clean with damp cloth. Easy to install... can be cut with ordinary scissors, goes on with ordinary linoleum paste. Entire wall can be installed in one piece. Information from Sandura Company Inc., Dept. AB, 17th and Sansom Sts., Philadelphia, Pa.

Circle No. 7145 on reply card, p. 148

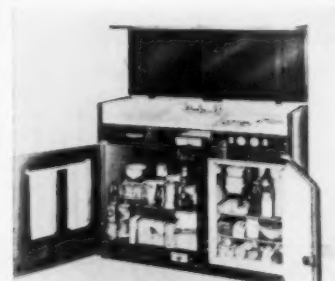

Complete kitchen in one compact cabinet

Dwyer "400" is styled as a furniture piece yet opens up to reveal cooking burners, work area and deep-bowl sink built into a streamlined, crevice-free counter of white vitreous porcelain. Beneath is modern refrigerator and storage cupboard with push-button doors. Simple installation with only normal lighting and wiring needed. Dwyer "400" unit comes in mahogany or blonde modern cabinet. Single lock secures both doors and top against intrusion. Information from Dwyer Products Corp., Dept. AB, Attn. W. B. Myers, Michigan City, Ind.

Circle No. 7146 on reply card, p. 148

CUT CHIMNEY COSTS FOR BIGGER PROFITS!

FREE!

Write today for "HOW TO CUT CHIMNEY COSTS". This valuable free booklet gives *job-tested, proven* ways to save time, labor and money . . . build houses faster and at less cost. Don't wait. It's money in your pocket!

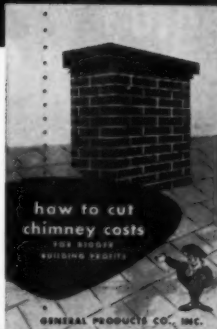

how to cut chimney costs
FOR BIGGER BUILDING PROFITS

GENERAL PRODUCTS CO., INC.

AIR-JET PACKAGED CHIMNEYS -- FOR A FIVE STAR SAVINGS



- ★ 1. TIME
- ★ 2. LABOR
- ★ 3. MONEY
- ★ 4. WORRY
- ★ 5. SPACE

AIR-JET "CONTEMPORARY" AB-3



GENERAL
PRODUCTS COMPANY, INC.
Fredericksburg, Va.

A WasteMaster Adds More "Sell" to The Homes You Build!



- Immediate delivery!
- Priced right!
- Exclusive "Shavitron" Shredder keeps drains clean and free . . . ideal for septic tank use!
- Umbrella Slinger keeps motor dry . . . always!
- No vibration!
- Easy installation!

WRITE TODAY for detailed information!

A PRODUCT OF THE
LOCKLEY MACHINE COMPANY

WASTEMASTER DIVISION
310 GROVE STREET NEW CASTLE, PA.

HOW TO GET ON THE PROFIT SIDE WITH PREHUNG DOOR UNITS

You can be the one in your area to offer complete precision Master Prehung Door Units (exterior or interior) at an unbelievable low cost. The demand for prehung door units is growing rapidly and you can be the one to develop this business in your area.

With Master Prehung Door Manufacturing Equipment* high speed, trouble free assembly of wood doors, sash jamb and trim both sides can now be accomplished economically. Machines come pre-set so the first unit and every other unit will be perfect.

WRITE TODAY for complete information.

*Covered by Pat. & Pat. Pending.

MASTER PREHUNG DOOR EQUIPMENT

Z & K Tool Company

407 Sand Hill Road, Lebanon, Pa.

*This FREE
booklet
tells you...*

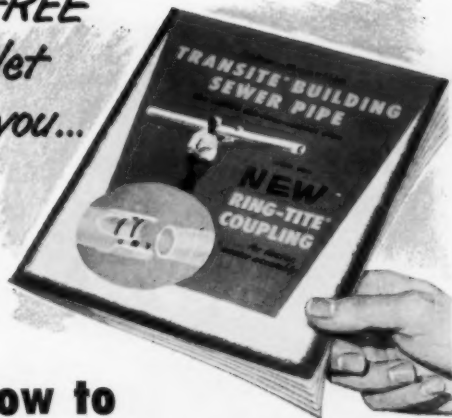

... how to save money in installation



1. Lubricate by hand!



2. Lock tight by hand!

That's all you do to assemble Transite Building Sewer Pipe. The rubber rings in its Ring-Tite Coupling and in sockets of all Transite Building Sewer Pipe Fittings are pre-positioned at the factory. The job is simple ONE-TWO operation!

HERE is an 8-page booklet filled from cover to cover with helpful, factual information.

By means of charts, diagrams, photographs and descriptions, it gives the reasons why Transite® Building Sewer Pipe is called "the plumber's pipe" . . . why it installs faster, easier . . . why its Ring-Tite® Coupling keeps roots out of house-to-street-sewer lines . . . why fewer joints are needed. You'll also find illustrations of the wide adaptability made possible by the use of Transite asbestos-cement Pipe, Fittings and Adaptors.

Mail the coupon for your copy of TR-82A, "Transite Building Sewer Pipe." Why not do it now?

Johns-Manville TRANSITE PIPES FOR THE HOME

Building Sewer . . . Plumbing Vent
Gas Vent . . . Warm Air Duct



Johns-Manville, Box 60, New York 16, N. Y.
(In Canada, Port Credit, Ontario)

Please send me your new booklet TR-82A,
"Transite Building Sewer Pipe."

Name _____

Company _____

Street Address _____

City _____ Zone _____ State _____

ANNOUNCING... New Remington Cartridge-Powered Tool for Stud Fastenings



**REMINGTON "MIGHTY MITE"
STUD DRIVER sets a stud a
minute in steel or concrete!**

Here's the "MIGHTY MITE"—small but powerful partner of the full-size Remington Stud Driver—the answer to any job requiring a $\frac{1}{4}$ " diameter stud. It's the perfect tool for builders, light contractors and the "do-it-yourself" market... can be rented or purchased. You can buy it for only \$34.75!

The "MIGHTY MITE" has only three parts to handle... easy to load and operate. The upper assembly is unscrewed, the 22 caliber cartridge with the desired $\frac{1}{4}$ " stud is inserted, and it's ready to go. One rap of the hammer on the firing pin, and "MIGHTY MITE" rigidly anchors wood sections or steel fixtures to concrete or steel! No pre-drilling required.

Safe, too. It's non-tilt—cannot be fired at an angle; cocks only when held in the proper firing position; must be pushed firmly into position to expose the firing pin. A four-inch-square guard provides full protection to the operator.

Send for the facts about the REMINGTON "MIGHTY MITE"—small, powerful and ideal for your construction job—at the lowest possible price—

ONLY
\$34⁷⁵



Another great **NEW** cartridge-powered industrial tool by

Remington



Industrial Sales Division, Dept. AM-7
Remington Arms Company, Inc.
Bridgeport 2, Conn.

Please send me your free booklet which shows how I can speed the job and save with the new Remington "Mighty Mite" Stud Driver.

Name _____ Position _____
Firm _____
Address _____
City _____ State _____

AMERICAN BUILDER NEW PRODUCTS

KITCHENS

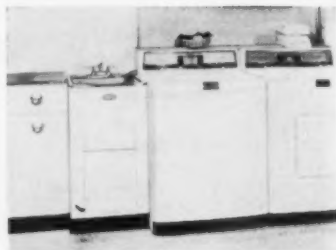

**Twenty-gallon Duratub
styled for laundry**

Duratub laundry tub is designed and engineered for use with automatic washers and other laundry equipment. Features include 20-gallon tub of green Fiberglas that will not crack or stain; white baked enamel exterior on heavy bonderized steel; stainless steel trim; legs adjustable to full $1\frac{1}{2}$ "; triple-duty automatic washer drain and overflow tube; convenient storage compartment at bottom with sliding panel door to save space. Information from E. L. Mustee & Sons, Attn. Frank Mustee, Dept. AB, 6911 Lorain Ave., Cleveland 2, Ohio.

Circle No. 7147 on reply card, p. 148



**Built-in cooking units
are easily installed**

Tennessee Stove offers a wide selection of built-in cooking units: gas or electric ovens, two and four burner cooking units. Photo shows a four burner electric top unit going in with cabinets and drawer space underneath. Units are available in either stainless steel or combination of non-tarnishing antique copper porcelain accented with wrought iron black. Banquet size built-in ovens come with automatic clock controls and oven lighter, as well as hood over oven vent. From Tennessee Stove Works, Attn. W. T. Bullard, Dept. AB, Chattanooga 1, Tenn.

Circle No. 7148 on reply card, p. 148

This is for me!

A REPUBLIC STEEL KITCHEN WITH A STAINLESS STEEL SINK

The lovely, durable, practical satin finish that bespeaks quality! ENDURO® Stainless Steel sinks — in a full range of sizes — are stock items in Republic Steel Kitchens. And at a reasonable price. What a sales feature for your homes! If you are not yet using this modern "designed for built-ins" line, you're not getting the most for your kitchen dollar. Check your costs, then see what the flexibility of the Republic Steel Kitchens line can offer you—regardless of price bracket. And no extra cost for Harmony Hues!

REPUBLIC STEEL MEANS SERVICE, ECONOMY

Republic Steel, alone, offers the economy of mine-to-market production. Dependable service. Planning guidance. Economical installation. Quality that eliminates expensive call-backs. Get the complete story from your Republic Steel Kitchens distributor, or use the coupon.

REPUBLIC STEEL KITCHENS

in Harmony Hues

in Classic White • Largo Yellow
Tempo Turquoise • Prelude Pink

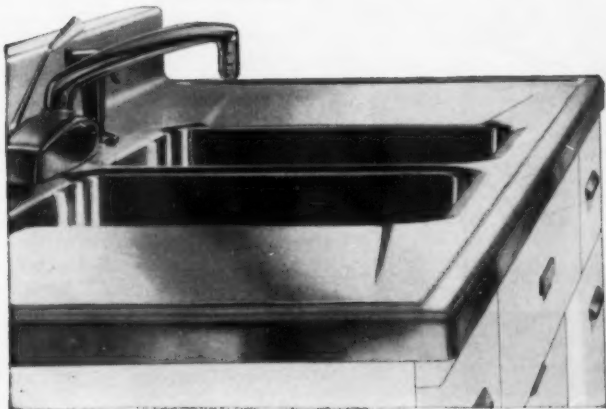

REPUBLIC STEEL KITCHENS, Builder Sales
1038 Belden Avenue, Canton 5, Ohio

Send me complete information on Republic Steel
Kitchens and the name of my nearest distributor.

Firm _____

Individual _____

Address _____

City _____ Zone _____

County _____ State _____

AB-467

C-1327-A

*'as a builder
interested in offering
my home buyers more...
but keeping
my own*

Costs Down"



**I Like
The FASCO
POWER-HOOD**

because

It Takes No Cabinet Space

My prospective home buyers are all aghast when I open the above-stove cabinet and show them it's empty... With the Power-Hood the ventilator is completely contained in the hood... absolutely no loss of cabinet space by ventilator or duct installations.

It Slashes Installation Costs

Comes pre-wired... installs with just one duct opening and six sheet metal screws... And there's absolutely no time-consuming cabinet cutting.

It Offers Highest Efficiency of All

The new, exclusive, super-powered Fasco TURBO RADIAL IMPELLER WHEEL offers higher air delivery, less noise... than all other conventional blower wheel ventilators... even on long duct installations. And it requires no servicing.

and look...

The Hood is Adjustable...

Will Fit Exactly The Hood Space I Have... From 30" to 42". And it adjusts to fit non-plumb installations where walls and cabinets are not square.

Available in White and Copperoid Enamel,
Solid Stainless Steel.

**GET COMPLETE DETAILS AND PRICES TODAY... YOU'LL BE
SPECIFYING FASCO POWER-HOOD TOO!**

FASCO Industries, Inc. 21 AUGUSTA ST
ROCHESTER 2, N. Y., U. S. A.

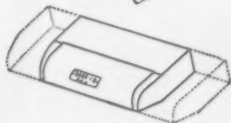
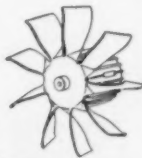
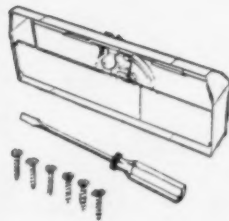

AMERICAN BUILDER NEW PRODUCTS

KITCHENS



Steel cabinets designed to fit any kitchen

Going up along the walls of this kitchen are Lyon steel kitchen cabinets, designed to fit all makes of built-in ovens and cooking tops as well as ordinary kitchen requirements. For each oven unit manufacturer, Lyon recommends a specific type of cabinet. All have Tap-O-Matic handles, insulated doors, rounded corners, are of bonderized, baked synthetic finish over zinc-coated steel. Further information on complete line from Lyon Metal Products Inc., Dept. AB, Aurora, Ill.

Circle No. 7149 on reply card, p. 148

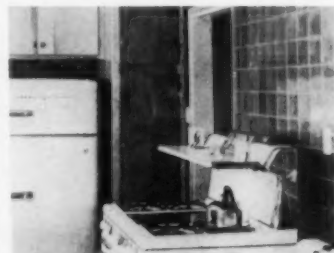

Decoration and protection with kitchen tiling

Kitchens (and bathrooms, too) will benefit from remodeling with Alumi-wall. Waterproof and rustproof, the tile wall paneling has shiny baked-on plastic finish which is unharmed by water, is easy to clean and won't be harmed by heat or grease. Alumi-wall can be installed on any solid wall surface, will keep its color and appearance for years. Available in unlimited color combinations to harmonize with existing color schemes. More information from Bestile Manufacturing Co., Attn. Sherwin Grossman, Dept. AB, 419 S. Sultana Ave., Ontario, Calif.

Circle No. 7150 on reply card, p. 148



BACKHOE-LOADER COMBINATION

JOHN DEERE
Utility Tractor →
 and Equipment

... ONE Basic Unit ...
All These Attachments!

IT'S like eating your cake and having it, too—the way a John Deere Utility Tractor and working equipment will step up the amount of work you can do without increasing your costs.

No matter what make of tractor you are now using—or what tractors you have operated in the past—we believe you will agree you never saw a tractor and equipment that will do so much work, pound for pound, dollar for dollar.

You don't pay for a lot of extras—features like Touch-o-matic hydraulic equipment control, heavy-duty 3-point hitch, and comfortable spring-cushion operator's seat are built right in—yours at no extra cost.

All we ask is that you accept our offer to test-drive a John Deere and make your own comparisons. What could be fairer than that?



Wheel Scraper



Front Blade



Portable Mixer



Clamshell

Plus Many Other Power-Matching Tools

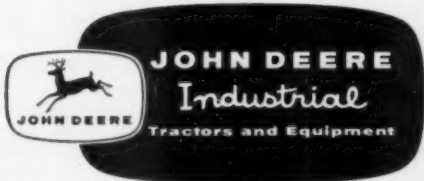

SEND FOR FREE LITERATURE

Please send me latest literature on:
 Utility Crawler

John Deere Industrial Division, Moline, Illinois. Dept. D33C

Name _____
 Firm _____
 Address _____
 City _____ State _____



7½-yard Tournapull shaped backslopes while grading roads around Mauvilla subdivision, also leveled and sloped land for drainage.

How Alabama Contractor levels land, builds roads for 3 new subdivisions...

Williams & Bouler, of Mobile, keeps land-leveling and road-grading ahead of *three* construction crews with *one* modern rubber-tired earthmover. Using their one-man 7½-yard D Tournapull, which runs from job-to-job at speeds to 28 mph, this contractor maintained continuous load-haul-and-spread grading service on 3 widely scattered jobs:

- 1 Moving 50,000 cu. yds. of clay for Mauvilla Forest Estates Subdivision in Chickasaw, a suburb of Mobile. Job included leveling area and grading 1½ miles of road.
- 2 Moving 15,000 cu. yds. of sand at another housing project.
- 3 Assisting in earthmoving for construction of 3 miles of highway known locally as the "Snow Road".

All 3 jobs were handled at the same time. When the clay at Mauvilla got too wet from rain, or when dirtmoving got well ahead of schedule, the rubber-tired "D" traveled under its own power to one of the other jobs... moved sand on 2nd housing project, or worked on Snow Road, 12 miles from housing sites.

It is easy for 28' Tournapull to maneuver around trees, spread or self-load in restricted areas. A money-saving one-man operation!



In engineer's time studies made at the Chickasaw housing project, the D Tournapull completed typical 2,000' cycles in about 3½ minutes. This included time to spread carefully around trees left standing to beautify the area. Contractor estimated loads in heavy clay varied from 5½ to 6 pay-yards. Machine averaged 15 trips, carried 82 to 90 pay-yards per hour.

At speeds to 28 mph, D Tournapull makes a 12-mile move in less than half an hour. Electric controls, geared king-pin steer, and multiple-disc brakes make handling accurate and easy. Big 5' rubber tires roll safely over city streets or cross-country, do no damage to curbs or pavement.

Cut costs with Tournapulls

If you do land-leveling, drainage, and road construction, ask for owner-verified reports on how Tournapulls can help you cut costs on these operations. Find out, too, how the scraper unit can be interchanged with rear-dump, side-dump, or lift-and-carry crane trailing units, for multi-purpose use with same prime-mover. You'll find these interchangeable trailing units add extra profit opportunities and fit into any future work pattern. Write for illustrated catalog.

If you subcontract your earthmoving, we will be glad to send you a list of D Tournapull owners who can speed this work and save you time and money.

Tournapull—Trademark Reg. U. S. Pat. Off. DP-803-B-z

**LeTourneau-
WESTINGHOUSE
Company**

Peoria, Illinois

A Subsidiary of Westinghouse Air Brake Company

AMERICAN BUILDER NEW PRODUCTS

KITCHENS



Dormalux kitchen nook hangs on walls

One corner of an old kitchen can be transformed easily into a breakfast nook with the installation of a Dormalux unit. Dormalux comes complete with nail or screw wooden cleats to fasten to wall. Then upholstered seats and backs may be dropped into place on cleats. Unit has open base, will not interfere with heating outlets. Choice of 4 sizes. Comes in pink, red, gold, toast, charcoal, green and blue in elastic-backed vinyl fabrics and Formica-topped tables. Information from Dormalux Co., Dept. AB, 50 Mechanic St., Buffalo 2, N.Y.

Circle No. 7151 on reply card, p. 148



Laundry tubs complement washers and dryers

Wesglas tubs are suggested as an auxiliary to washers and dryers in the remodeled kitchen or laundry area. Removable overflow tube in unit eliminates necessity of double tubs and allows free use for hand washing, soaking or bleaching. Large storage area in the Wessels cabinet provides space for storing laundry supplies. Tub itself is of Owens Corning Fiberglas, impervious to detergents, will not stain or craze. Wessels Co., Dept. AB, 1625 E. Euclid Ave., Detroit 11, Mich.

Circle No. 7152 on reply card, p. 148

FREE
 send
 coupon
 today!

CHASE BRASS & COPPER CO., WATERBURY 20, CONN.
 Dept. AB-756

Gentlemen:
 Please send me your free 50-page book titled: CHASE COPPER ROOFING PRODUCTS. I understand it contains a wealth of factual material I can use profitably on roofing and waterproofing jobs.

NAME _____
 COMPANY _____
 ADDRESS _____
 CITY _____ STATE _____

This 50-page book can help you save time on every roofing job!

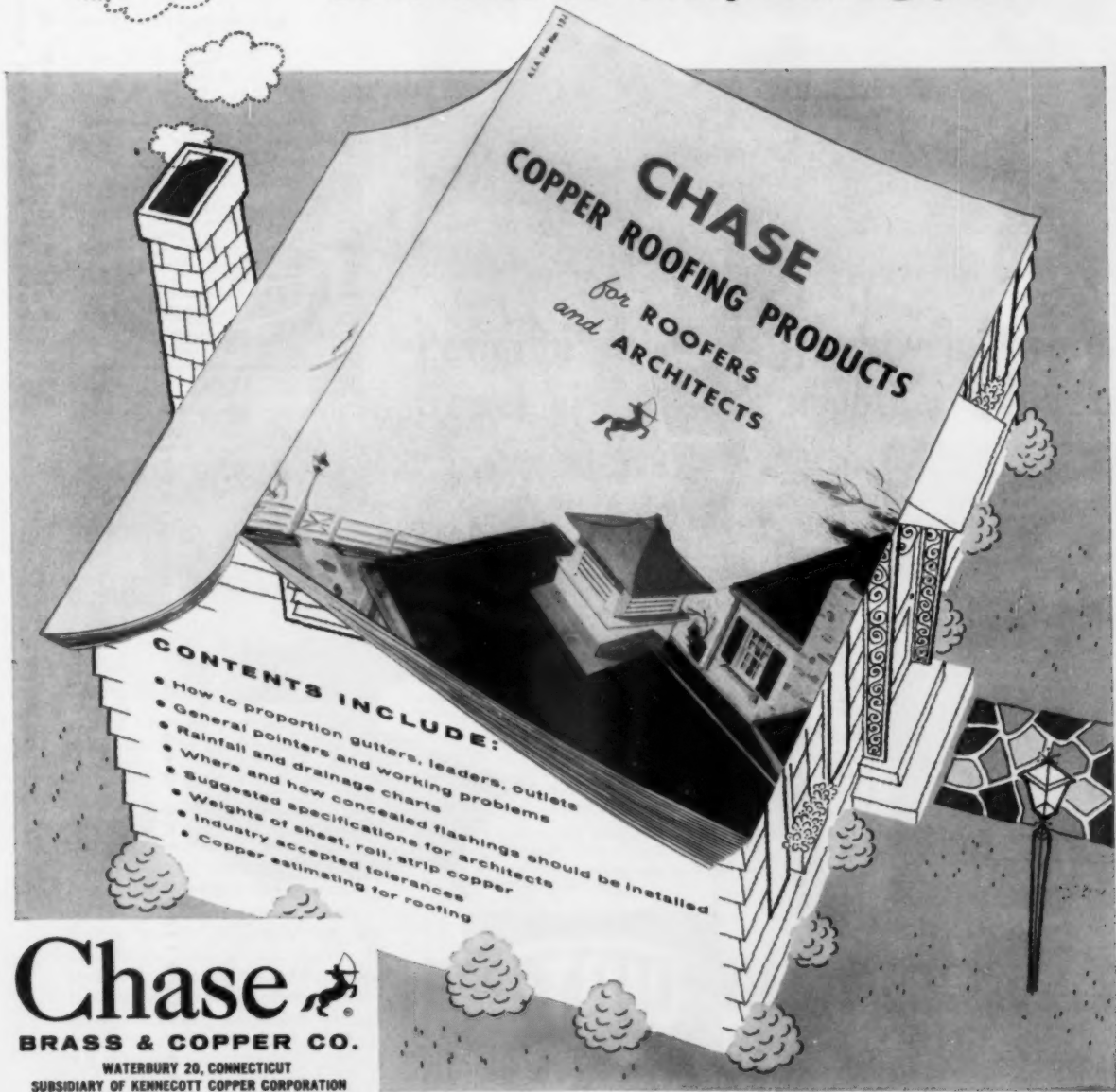

Chase 
BRASS & COPPER CO.
 WATERBURY 20, CONNECTICUT
 SUBSIDIARY OF KENNECOTT COPPER CORPORATION

The Nation's Headquarters for Brass, Copper and Stainless Steel
 Atlanta Baltimore Boston Charlotte Chicago Cincinnati Cleveland Dallas Denver Detroit Grand Rapids Houston Indianapolis Kansas City, Mo. Los Angeles Milwaukee Minneapolis Newark New Orleans New York Philadelphia Pittsburgh Providence Rochester St. Louis San Francisco Seattle Waterbury

THE "House and Garden" . . . NEW FROM SCHOLZ HOMES

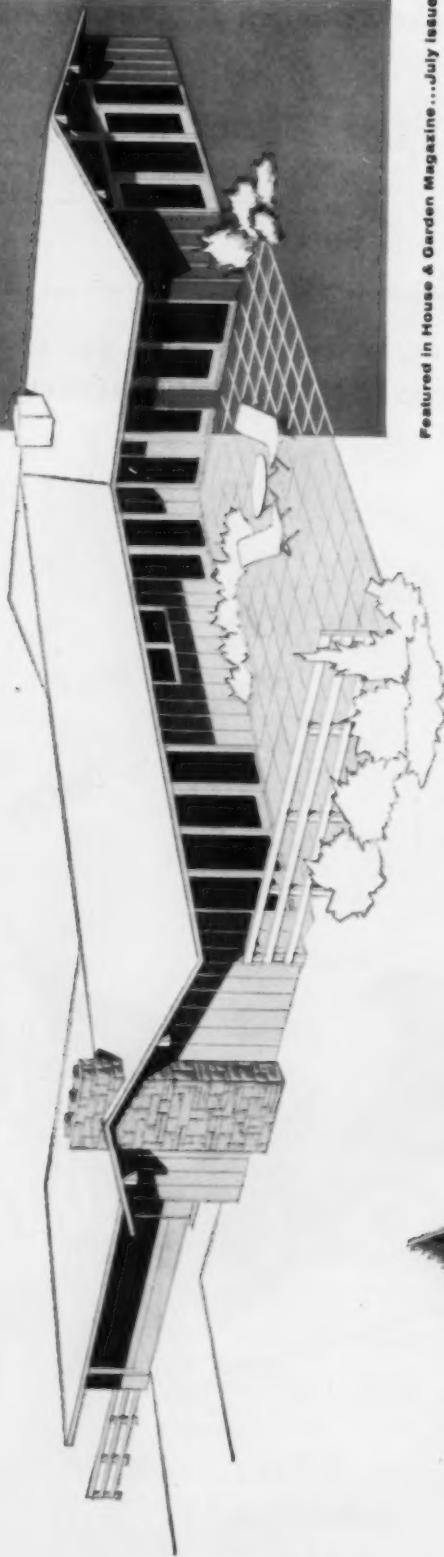

Featured in House & Garden Magazine . . . July Issue



the quality . . . the design . . . sells itself . . .



California Contemporary

SCHOLZ HOMES, INC. • 2001 N. WESTWOOD • TOLEDO 7, OHIO
 FOOT OF CHRISTIANA AVENUE • WILMINGTON, DELAWARE

KITCHENS



Steel in kitchens for variety in remodeling

Tracy kitchens present a line of steel cabinets with all manner of remodeling possibilities. Featured among Tracy lines are firm's new Picador cabinets, so named because builder or home owner can pick door material and colors before sliding doors are fitted into Tracy steel cabinets. Choice of perforated or solid hardboard or frosted glass doors. Other lower storage units including stainless steel sinks also available. Information from Tracy Div. of Edgewater Steel Co., Dept. AB, P.O. Box 1137, Pittsburgh 30, Pa.

Circle No. 7153 on reply card, p. 148



Wood kitchen cabinets can take variety of finishes

Kitchen cabinets by Curtis come in sturdy even-grained wood which can be stained or finished in a natural finish. Drawer fronts and doors are in natural birch. All cabinets in modern design with attractive, adjustable, semi-concealed hinges. Styles include sliding trays for kitchen utensils, swing shelves in wall and base square corner units, lazy Susan revolving shelves, step-saving "Island" units. Information from Curtis Woodwork Co., Dept. AB, Clinton, Iowa.

Circle No. 7154 on reply card, p. 148

FOR MORE KITCHEN REMODELING IDEAS, SEE P. 94

how to cut costs on concrete finishing



Powerful, new STOW lightweight roto-trowel gives faster, smoother finishes!

Here is a new, rugged, lightweight rotary trowel that works fast, leaves surfaces really smooth!

The G-24 Roto-Trowel weighs only 69 lbs. and because it is only 24 inches wide, can be easily carried anywhere, through doorways or down stairs . . . finishes so smoothly that hand work is no longer required. And it's so easy to use . . . you can be an expert in 15 minutes. Floats and finishes driveways, terraces, cellar floors, sidewalks, and porches. Trowel blade tilt can be controlled by the knob on the handle *while the machine is running*. A safety clutch control on the handle stops the trowels from rotating the instant the handle is released. A sturdy guard ring lets you work right up to walls and around pipes.

The Stow G-24 Roto-Trowel is low in cost, too, compared to large models. It has a 2.2 HP engine, making it the most powerful trowel in the low-priced field. As one contractor said about the G-24, "This is one of the best buys I have ever made."

Stow also makes a 29 inch, 34 inch and 46 inch trowel, concrete vibrators and screeds. Send in this coupon, if you'd like more information. We'll send you our Catalog 560. Write Today.



STOW MANUFACTURING CO.

142 Shear St., Binghamton, New York

Please send G-24 Roto-Trowel bulletin showing on-the-job photos, specifications, prices.
ATTENTION OF
FIRM **STREET**
CITY **STATE**



This seal represents the
BIGGEST PROFIT OPPORTUNITY
 you've had in years . . .

AND TOP-QUALITY CERTAIN-TEED PRODUCTS

**can help you make
 the most of it!**

"Operation Home Improvement" is underway . . . and the whole building and home-modernization market is the target!

Endorsed by the U.S. Chamber of Commerce, supported by builders, lenders and manufacturers all over the nation, OHI is a *new* idea, a *big* idea. It's designed to awaken homeowners everywhere to the vital need for improving and modernizing their dwellings . . . and to make it easier for them to buy the right materials and services.

OHI isn't scheduled for a week . . . or a month . . . but for all of '56—the year to FIX. It means more and more families will be adding rooms, finishing attics and basements, building porches and garages . . . right in your locality. And it means you can capitalize more than ever before on the reputation and acceptance that Certain-teed building products enjoy.

Join the OHI profit parade! There's a dealer near you who can supply you with all the quality Certain-teed products you need.



ROOFING JOBS. Certain-teed Asphalt Shingles, including extra-tough, smartly-grained Woodtex® shingles, will be in big demand during Operation Home Improvement—which will run throughout "56—the year to Fix."



SIDING JOBS. Certain-teed Asbestos Cement Siding Shingles and Asphalt Insulating Siding give homeowners a wide choice of colors and styles. Certain-teed Asphalt Shingles and Roll Sidings also available.



INSULATION JOBS. Certain-teed Fiberglas® Insulation—batts, blankets, pouring wool—will be needed on many modernization jobs turned up by nationally promoted Operation Home Improvement.

*Trademark OCF Corp.

Certain-teed

REG. U.S. PAT. OFF.

Quality made *Certain* . . . Satisfaction Guaranteed



CERTAIN-TEED PRODUCTS CORPORATION

ARDMORE, PENNSYLVANIA
 EXPORT DEPARTMENT, 100 EAST 42ND ST., NEW YORK 17, N.Y.

ASPHALT ROOFING • SHINGLES • SIDING • ASBESTOS CEMENT SHINGLES
 GYPSUM PLASTER • LATH • WALLBOARD • SHEATHING • ROOF DECKS
 FIBERGLAS BUILDING INSULATION • ROOF INSULATION • SIDING CUSHION
 PAINT PRODUCTS—ALKYD • LATEX • CASEIN • TEXTURE • PRIMER-SEALER

THE LATEST INFORMATION IS YOURS FOR THE ASKING

More remodeling help . . . starting on this page, more than 35 catalogs containing detailed remodeling ideas. Complete remodeling story begins "up front" on page 73. Use reply card, p. 148.

ADD NEW SPACE with use of folding stairways. Advantages of Precision and Simplex wooden folding stairways explained with pictures, diagrams and specifications in a four-page brochure. From Precision Parts Corp., Attn. George H. Harmon, Dept. AB, 400 N. First St., Nashville 7, Tenn.

Circle No. 7155 on reply card, p. 148.

MODERNIZING THE HOME with Kwikset locksets, told in a four-page catalog complete with step-by-step installation photos of a new door lock. This and information on various designs available from Kwikset Sales and Service Co., Attn. William Thomas, Dept. AB, 516 E. Santa Ana St., Anaheim, Calif.

Circle No. 7156 on reply card, p. 148.

FOLDING DOORS and how to install them illustrated with step-by-step sketches in literature from Curtition Corp. Accordion fold doors and their numerous uses in remodeling also detailed in other catalogs. Curtition Corporation, Attn. John A. Klumpp, Dept. AB, 2227 Sawtelle Blvd., Los Angeles 64, Calif.

Circle No. 7157 on reply card, p. 148.

REFINISHING WITH TILE in new decorative patterns is the subject of a six-page, full color pamphlet on Ceratile. Genuine clay tile illustrated in 21 decorator designs and patterns for different wall uses. From Pacific Tile & Porcelain Co., Dept. AB, 7716 E. Olive St., Paramount, Calif.

Circle No. 7158 on reply card, p. 148.

HOUSE ADDITIONS like carports, porch covers, awnings, breezeways, fences, partitions, described with photos, "how-to" sketches, and working diagrams in this eight-page

catalog. Uses of translucent Resolite panels and specifications also detailed. Resolite Corporation, Attn. Bernard E. Magette, Dept. AB, Zelenople, Pa.

Circle No. 7159 on reply card, p. 148.

ACCENT ON ACCESSORIES by Hall-Mack in an eight-page color brochure. Full line of accessories to remodel and refurbish the bathroom presented with photographs, sketches and specifications. Available from Hall-Mack Co., Attn. DeWald McDonald, Dept. AB, 1380 W. Washington Blvd., Los Angeles 7, Calif.

Circle No. 7160 on reply card, p. 148.

VERTICAL BLINDS for windows, skylights, room dividers and a number of other uses. Louverdrapes traversing vertical blinds rotate to any fixed position for control of light and air. Described in a four-page catalog complete with photographs and sketches. Vertical Blinds Corp. of America, Attn. James Clayton, Dept. AB, 1936 Pontius Ave., West Los Angeles 25, Calif.

Circle No. 7161 on reply card, p. 148.

MODERNIZING WITH WINDOWS, doors, venetian awnings, terrace canopies. Literature with full color drawings, sketches, specifications available on Rusco metal awnings; all-weather jalousies; porch enclosures; and combination windows and doors. From F. C. Russel Co., Attn. Harry P. Wiseman, Dept. AB, 1100 Chester Ave., Cleveland, Ohio.

Circle No. 7162 on reply card, p. 148.

FOR RE-WIRING INFORMATION, an eight-page catalog on Touch-Plate low voltage switch system. Modular units completely pre-wired, color coded, assembled for use in multi-

ple on any size installation. Photos and descriptions of complete line from Touch-Plate Mfg. Corp., Attn. K. P. Cronk, Dept. AB, Box 1970, Long Beach, Calif.

Circle No. 7163 on reply card, p. 148.

HARDWOOD BLOCK FLOORING to renew old floors, give "new look" to rooms suggested by Wood-Mosaic in a full-color pamphlet. Laminated block hardwood flooring in natural finish oak, walnut, birch, cherry and toast-brown finish oak. Available from Parkay Inc., Attn. J. J. Egan Jr., Dept. AB, Louisville 9, Ky.

Circle No. 7164 on reply card, p. 148.

CHOOSING THE RIGHT ROOF for redoing the home is the subject of a 28-page, full color catalog by Barrett Shingles. Technical data, drawings, description of different types of shingles plus true color photos of color schemes for homes. From Barrett Div., Allied Chemical & Dye Corp., Attn. A. G. Husen, Dept. AB, 40 Rector St., New York 6, N.Y.

Circle No. 7165 on reply card, p. 148.

OLD KITCHENS AND NEW can be planned with the help of Norris-Thermador's "Sketch Book of Kitchen Plans." An eight-page catalog of drawings, floor plans and detail sketches. Information on electric built-in ovens also available. From Norris-Thermador Corp., Attn. Jeanne C. Riggs, Dept. AB, 5215 S. Boyle Ave., Los Angeles 58, Calif.

Circle No. 7166 on reply card, p. 148.

GARAGE REMODELING with upward-acting sectional garage doors suggested in this illustrated brochure from Graham Door Sales. Eight different models pictured together

(Continued on page 204)

CONCRETE FORMING is no puzzle when you choose



Gates has *Research-Engineered* Forming Systems, designed to meet specific needs on *any* type forming job. Every Gates System has been job-tested for lower overall costs through fast, efficient, more versatile forming. No large initial investment.

Select the Gates System best suited to your needs.

- Horizontal Rod Panel Systems
(high or low wall)
- 2 x 4 Panel System
- Sheathing Systems
(rod or 2 x 4)
- Low Wall Strap Tie System
- Vertical Rod Low Wall System
- Commercial System

For detailed information, contact your Gates Dealer or write direct.

A3 7/54

GATES & SONS, INC.

80 So. Galapago Street • Denver 23, Colorado

7 BESSLER

DISAPPEARING STAIRWAY MODELS
TO MEET EVERY NEED!



FREE CATALOG
AND
WALL CHART

AS LOW AS

\$53⁰⁰ LIST

Generous
Trade
Discounts!
Write for
Free Catalog
and Wall
Chart

BESSLER DISAPPEARING STAIRWAY CO.

1900-A East Market St., Akron, Ohio

Bessler Disappearing Stairway Co., 1900-A East Market St., Akron 5, Ohio

Please send free Catalog, Wall Chart, Prices and Discounts

Name

Address

City Zone State

the new MULLER POWER TROWELS

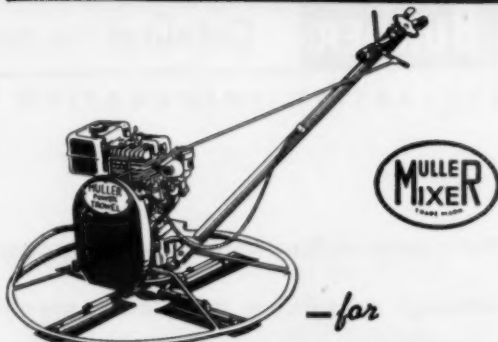

—for
easier handling and smoother jobs

These new 4-Blade Power Trowels finish concrete smoother than conventional 3-blade types. They can get on the concrete sooner, and are much less tiring to the operator because vibration and lateral pull are greatly reduced.

Blade adjustment, engine throttle and power throw-out are conveniently located at the top of the handle. Timken Bearings maintain accurate alignment in all four sizes—24", 29", 34" and 44". Separate Floating and Finishing Blades are standard equipment.

Send for folder, prices, name of nearest dealer.

MULLER MACHINERY COMPANY, Inc.
Metuchen 4, N.J. Cable Address MULMIX

Now!
CUT COST...
BOOST PRODUCTION

Katolight

On The Job...

PORTABLE POWER

KATOLIGHT Portable Generators give you quick power . . . when and where you want it . . . for operating electric saws, grinders, sanders or paint sprayers. No delays . . . no nuisance with powerline hook-ups. Available on dollies or on trailers. A.C. Models from 350 Watts through 50 KW.

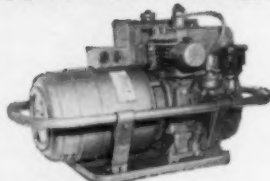

WRITE FOR FREE INFORMATION

Katolight CORPORATION
Box 891-25

Mankato, Minnesota

CONVENIENCES UNLIMITED
in KITCHEN, SHOWER & LAVATORY

GYRO

**SINGLE-HANDLE
MIXING FAUCETS**

The Proven Faucet with

- DRIP-PROOF SERVICE
- EFFORTLESS OPERATION
- TROUBLEFREE SATISFACTION
- STREAMLINED APPEARANCE
- NO SCALDING HAZARDS

Write for FREE folder to:
GYRO BRASS MFG. Dept. A Westbury I.I.N.Y.

A
SINGLE
HANDLE
CONTROLS
VOLUME
AND
TEMPERATURE



"Worthington air conditioning biggest sales feature!"



Illinois builder of 350-home project sold on Worthington units

Any home that costs \$12,000 or more to build should be air conditioned!

That's how builder L. B. Pooley of Aurora, Illinois sees it. Air conditioning not only protects the buyer's investment, but also, makes a home easier to sell.

Most convincing proof of this is offered by the quality 350-home development now under construction by builder Pooley and his son Bob. Worthington's Year-Round unit has been speeding up sales ever since the project first got underway.

Pooley explains his choice of Worthington equipment like this:

"Worthington's Year-Round unit makes it easy for me to offer air conditioning as an optional feature. Heating and cooling sections come in one trim-looking cabinet that's a cinch to install. If a prospect wants to hold off on air conditioning, I install the heating unit first. The cooling section can be added at *any time!*"

Like Mr. Pooley, you can make Worthington air conditioning the feature that sells your homes this year. Call your Worthington dealer. He'll be glad to go over installation and cost details . . . and show you how Worthington's Year-Round unit will pay off in quick sales for you. You can also get full details by returning the attached reply card. Worthington Corporation, Air Conditioning and Refrigeration Division, Section A.5.45-AB, Harrison, N. J.

A.5.45



Builder Pooley likes the optional feature of Worthington's Year-Round Air Conditioner. Cooling section can be added at any time—it rolls into cabinet like a drawer.

WORTHINGTON



CLIMATE ENGINEERS TO
INDUSTRY, BUSINESS AND THE HOME

WORTHINGTON CORPORATION
Air Conditioning & Refrigeration Division
Section A.5.45
Harrison, N. J.

Gentlemen: Please send me information on
Worthington home air conditioning.

Name _____

Address _____

Ask us for
more facts about

WINDOWS by VENTO

(STEEL OR ALUMINUM)

Exclusive Features in

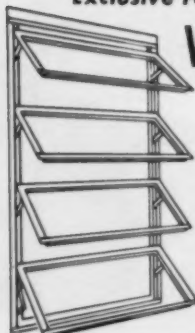

VENTO Aluminum Awning Windows

AUTOMATIC LOCKING... No gadgets to turn, no gimmicks to operate, nothing to get out of order.

WEATHER TIGHT... VENTO alone keeps metal to metal contact plus metal to weatherstrip.

UNLIMITED ADJUSTMENT... Unique in ability to be quickly returned to proper adjustment.

POWER PLUS OPERATOR... Screw — not worm geared — operator working in self-lubricating nylon journals.

EFFORTLESS OPERATION... Nylon roller blocks at all friction points permit finger tip operation.



VENTO Steel Casement Windows

All casements drilled and tapped to receive storm sash and screens, operator arm guide channels attached with screws for easy removal and replacement, if necessary; ventilator frames constructed from the same heavy sections as the outside frame to provide greater rigidity and stronger ventilators.

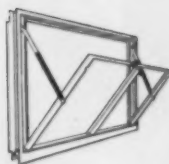

VENTO Bonderized "Champion" Steel Basement Windows

Effortless operation gives any of three ventilation openings, or sash removal. Sturdy 14 gauge jamb fins for easy installation in block or poured concrete walls. An improved cam latch and slotted opening allow greater tolerance, insuring positive operation and latching under all conditions. Basement sash also made in Thrifty style in three standard sizes and in special sizes. Both Champion and Thrifty styles available in putty or puttyless glazing. For poured basement walls, window forms available for both Champion and Thrifty styles to suit individual specifications.



Catalogs . .

(Continued from page 201)

with technical data. Available from Graham Door Sales Co., Attn. J. R. Graham, Dept. AB, 6901 Carnegie Ave., Cleveland 3, Ohio.

Circle No. 7167 on reply card, p. 148.

REAL WOOD in accordion-fold doors by Panelfold. Eight-page catalog in full color describes remodeling problems and solutions with many different types of Panelfold doors in wide variety of woods. Photos, line drawings, specifications included. From Panelfold Doors Inc., Attn. R. I. Geyer Jr., Dept. AB, 1090 E. 17th St., Hialeah, Fla.

Circle No. 7168 on reply card, p. 148.

REMODELING PORCHES with jalousie windows is described in a four-page brochure. Win-Daher jalousie windows with aluminum frames described with sketches, specifications, sizes and types for the remodeling job. Other literature on jalousie doors, residential and commercial installations. From Daher Products Corp., Attn. Jos. G. Daher, Dept. AB, 615 Salem Ave., S.W., Roanoke, Va.

Circle No. 7169 on reply card, p. 148.

BUILT-IN RANGES for the remodeled kitchen presented by Admiral. Custom electric ranges pictured with diagrams and detail drawings in a six-page brochure which also suggests different kitchen arrangements. From Admiral Corporation, Attn. Larry E. Coen, Dept. AB, 3800 Cortland St., Chicago 47, Ill.

Circle No. 7170 on reply card, p. 148.

TWENTY PLANS for home improvements with use of Structoglas, glass fiber reinforced plastic panels. Ten-page catalog shows sketches and detail drawings of remodeling garages, greenhouses, entry ways, rooms, etc. From International Molded Plastics Inc., Attn. Robert A. Grayson, Dept. AB, 4387 W. 35th St., Cleveland 9, Ohio.

Circle No. 7171 on reply card, p. 148.

DOOR OPENER by Alliance presents a "Genie" Lift-A-Door, an automatic garage door opener in pamphlets and brochures. Comes in two models: either key lock switch or radio controlled. Fully described in pamphlet, plus booklet on how to install. From Alliance Manufacturing Co., Inc. Attn. Roy Vandegrift, Dept. AB, Alliance, Ohio.

Circle No. 7172 on reply card, p. 148.

**VENTO
STEEL PRODUCTS
CO., INC.**

247 COLORADO STREET
BUFFALO 15, N. Y.

Please send further information on
Vento Windows as checked.

- AWNING TYPE ALUMINUM STEEL BASEMENT
 INDUSTRIAL AND COMMERCIAL FORMED STEEL LINTELS
 STEEL CASEMENT UTILITY

ARE YOU A BUILDER DEALER ARCHITECT

Name

Street

City and State

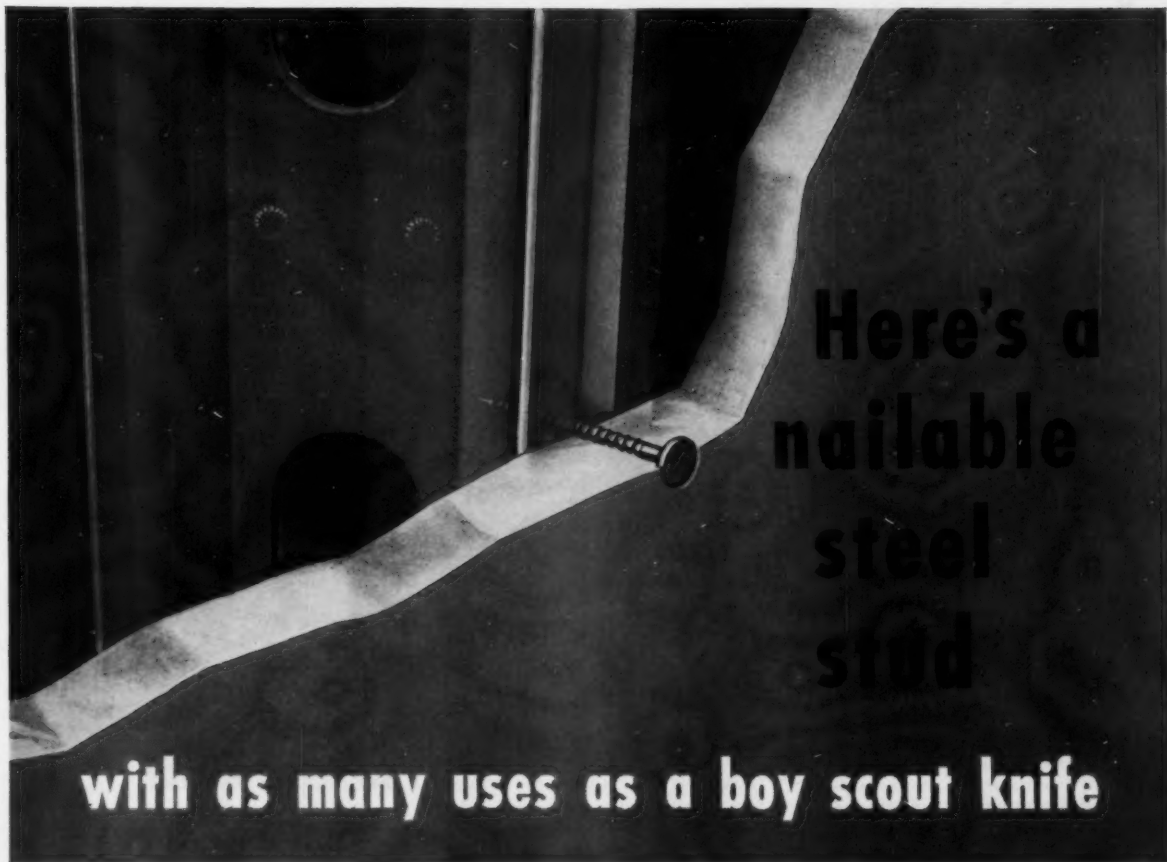

Here's a
nailable
steel
stud

with as many uses as a boy scout knife

If you've been looking for a low cost, non-bearing steel stud that's *nailable* — stop! You can find it in Penmetal's new *Permalok* stud system.

Consisting of *nailable* steel studs, track and bridging and the necessary washers, this system offers many advantages in the erection of non-bearing partitions. Collateral materials like metal lath, gypsum lath or virtually any type of panel can be secured to *Permalok* studs — as simply as to wooden ones. An ingenious nailing device bites the nail or screw with a never-loosening grip. What's more the face of the stud is wide enough to permit the butting of collateral material.

Components of the *Permalok* system are inexpensive per foot of partition. Because they are light in weight and fit together readily, they are *fast, easy* and *economical* to erect. Other benefits: *Fire-safety, permanence, strength, rigidity* and *simple disassembly*.

Write for new folder which describes Penmetal's adaptable, economical *Permalok* system in detail.

PENN METAL COMPANY, INC.

General Sales Office: 205 East 42nd St., New York 17, N. Y.

Plant: Parkersburg, W. Va.

District Sales Offices: Boston, New York, Philadelphia, Pittsburgh, Chicago, Detroit, St. Louis, Dallas, Little Rock, Seattle, San Francisco, Los Angeles, Parkersburg

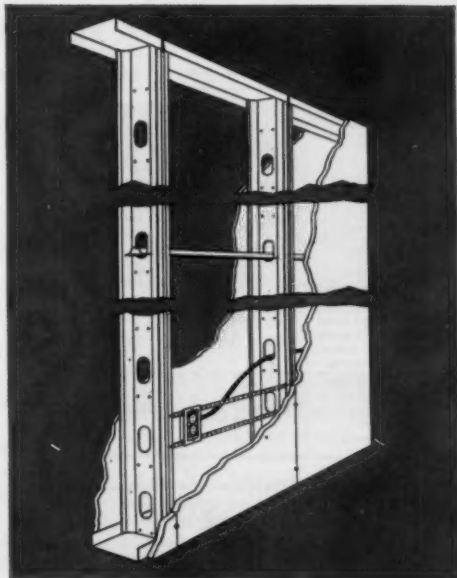

Typical panel assembly.



Here are important facts
for the "man behind the gun"



This White 18" Dumpy level has
... more of the
features you want,
yet costs you less!

Before you buy, compare this White Dumpy level with a similar model of any other recognized make. From every standpoint — design detail . . . quality construction . . . work-speeding, life-lengthening features and cost — you'll quickly see why a White's the best buy you can make. It will make your work faster, easier, more accurate. Check this comparison chart:

FEATURES	D. White No. 7080	Instrument	
		A	B
Magnifying power of telescope	35X	30X	27X
Distance away you can read 1/100 ft. graduation	1200 ft.	1050 ft.	900 ft.
Diameter of objective lens	1.81 in.	1.485 in.	1.69 in.
Field of view (in minutes of arc)	64'	52'	60'
Coated optics	YES	YES	YES
Covered leveling screws	YES	YES	YES
Can you easily replace worn leveling screws in the field?	YES	NO	YES
Sensitivity of level vial (in seconds of arc per 2mm of graduation)	20"	20"	25"
Price — complete with carrying case, tripod and accessories — F.O.B. factory	\$315.00*	higher	higher

For complete details on the 18-in. Dumpy level and other equally fine engineering instruments, see your David White dealer, or write direct to DAVID WHITE CO., 301 W. Court Street, Milwaukee 12, Wisconsin.



We offer complete, expert repair service on all makes, all types of instruments.

*Price subject to change without notice.

Catalogs . .

AIR CONDITIONING EVERYWHERE with a whole house air conditioning system designed to fit into any type home and described by the maker as easy to install and low in cost. Presented by Airtemp in an illustrated folder on its Airtemp 118 system. Specifications, diagrams and photos included. Airtemp Div., Chrysler Corp., Attn. J. L. McGarry, Dept. AB, Dayton, Ohio.

Circle No. 7173 on reply card, p. 148.

REDOING THE FLOOR from "How to Lay a Lifetime Floor of Northern Hard Maple" in an eight-page brochure. Diagrams, photographs and explanatory text on the advantages of such flooring, and just how to lay one. Available from Maple Flooring Manufacturer's Ass'n., Attn. L. M. Clady, Dept. AB, 35 E. Wacker Dr., Chicago 1, Ill.

Circle No. 7174 on reply card, p. 148.

"NEW IDEAS ON TILE" offered in twelve pages in full color of rooms remodeled with tile or newly decorated with it. Photographs of rumpus rooms, bathrooms, entry-ways, kitchens, along with numerous suggestions on color combinations and designs in tile. From American-Olean Tile Co., Attn. Louis D. Methfessel, Dept. AB, Lansdale, Pa.

Circle No. 7175 on reply card, p. 148.

MODERNIZING THE HOME described with fifteen types of older houses, remodeling solutions and before and after floor plans in this 20-page color catalog by Ruberoid. Complete details and color schemes on use of Ruberoid siding and roofing material included. From The Ruberoid Co., Dept. AB, 500 Fifth Ave., New York 36, N.Y.

Circle No. 7176 on reply card, p. 148.

UPDATING WITH SHOWERS with help of Fiat's cabinet showers, precast shower floors, shower doors and bath enclosures described in detail in a full color catalog. Illustrations and layouts on remodeling bathrooms to include showers included with complete instructions on how to install packaged shwgs. Available from Fiat Metal Mfg. Co., Dept. AB, 9301 Belmont Ave., Franklin Park, Ill.

Circle No. 7177 on reply card, p. 148.

INSTALLING GARAGE DOORS has complete instructions for the workman installing a Crawford upward-acting
(Continued on page 208)

SPACE-SAVING

Ideas

HELP
SELL THE
HOUSE



with

Kennatrack
SLIDING DOOR HARDWARE

SLIDING DOOR
HARDWARE

A gentle touch and the door slides quietly, effortlessly into the warp proof Kennaframe wall pocket. Ideas that save space, make more room for living — help sell the house. Write for complete KENNAFRAME folder today.



Take the guesswork out of Sliding Door Installations. Select the right hardware for every interior use from Kennatrack's easy-to-use Buyer's Guide. Write for your free copy.



Kennatrack
CORPORATION
ELKHART, INDIANA
In Canada: Toronto, Ontario



Majority of Dunbar Homes feature kitchens like this—225 are built and sold each year

"My prospects show more interest in Suburban than any other single feature in the house,"

says President of Dunbar Homes

"When a prospect comes across the Suburban Built-In Range in one of our kitchens, she's usually easier to sell," says Roger G. Dunbar, President of Dunbar Homes and Secretary of the Toledo Association of Home Builders, Inc. "That's why the majority of Dunbar Homes have built-ins—all Suburban. I considered several built-ins, but found . . .



Roger G. Dunbar President, R. G. Dunbar, Inc., Toledo, Ohio

. . . it had to be SUBURBAN

Dunbar Homes range from \$15,000 to \$30,000 and are found in Ottawa Estates, McKondin Heights, Parkview, Chevy Manor, Palma Orchards Extension and Edgehill. Current project is Elmhurst Park. Byrneway Park is planned for late 1956. Again, the majority of homes will feature built-in ranges, according to Mr. Dunbar—all Suburban.

Electric or Gas—Best deal yet for builders!

Whether your prospects prefer Electric or Gas, Suburban is the best deal for you. Here's why:

- One size cabinet opening fits both Gas & Electric Ovens
- More than 100 cook top combinations
- Gas & Electric units both fit the same size opening
- Extra broiler with Electric Models
- Closed Door broiling with Gas Models
- Quick, safe installation
- 40 Wife-Saver Features in all!

suburban

AMERICA'S FINEST BUILT-IN RANGE

GET FULL DETAILS TODAY—AT NO OBLIGATION!

Dept. AB-76 Samuel Stamping & Enameling Co.,
Chattanooga, Tenn.

At no obligation to me, please send complete information on
 GAS ELECTRIC Suburban Built-In Ranges.

Name _____ Title _____

Firm _____

Street _____

City _____ State _____

Catalogs . .

(Continued from page 206)

garage door in a large folder complete with step-by-step photos and diagrams. Also contains instructions for later door care for homeowners. Crawford Door Sales Co., Dept. AB, 20263 Hoover Rd., Detroit, Mich.

Circle No. 7178 on reply card, p. 148.

REMODELING AND MODERNIZING by adding a room with the help of Gold Bond is the subject of three plan brochures. All fully illustrated with floor plans, detail information, cut away drawings. One on adding a kitchen, one on a bedroom addition and the third on an extra family room. From National Gypsum Co., Attn. Robert F. Quinn, Dept. AB, Buffalo 2, N.Y.

Circle No. 7179 on reply card, p. 148.

RE-DO WITH HI-FI and Intercommu-

nication systems by Music and Sound described in a four-page catalog. Four models of intercom systems presented with photographs, technical data and drawings. For existing homes or new. Information from Music & Sound Inc., Attn. Harold J. Lemon, Dept. AB, 118 Leslie St., Dallas 7, Tex.

Circle No. 7180 on reply card, p. 148.

NEW OUTDOOR ELEGANCE by touching-up old homes or for a new home, Logan Co. suggests porch columns, railings and other fittings of ornamental iron. Described in a 16-page booklet complete with sketches, photos and specifications of many different designs in ironwork. From Logan Co., Attn. Carrie Ballman, Dept. AB, Louisville, Ky.

Circle No. 7181 on reply card, p. 148.

REMODELING WITH WINDOWS shown with before and after "shots," floor plans, diagrams and specifications on major uses of windows in remodeling. All in a 20-page booklet called a "Treasury of Ideas for Remodeling with Window Beauty." From Andersen Corp., Dept. AB, Bayport, Minn.

Circle No. 7182 on reply card, p. 148.

"MODERN SHEET COPPER Practices" is a 112-page illustrated manual edited especially for architects, specification writers, sheet metal designers and workers. New, comprehensive guide for correct uses of sheet copper. Manual C-1 from American Brass Co., Dept. AB, Waterbury 20, Conn.

Circle No. 7183 on reply card, p. 148.

THE DREAM BATHROOM in twenty pages of full color by Universal-Rundle on planning and decorating. Color schemes, floor plans, new arrangement of fixtures, and details on company's full line of fixtures. From Universal-Rundle Corp., Attn. W. A. Shaffer, Dept. AB, P.O. Box 960, New Castle, Pa.

Circle No. 7184 on reply card, p. 148.

FLOOR TILE of vinyl-asbestos "Flexachrome," in a four-page, four-color catalog which pictures a complete color chart of the product, together with details and explanations of its wearing features, sizes, installation, possible designs, etc. Available from Tile-Tex Div., Flintkote Co., Dept. AB, 1232 McKinley Ave., Chicago Heights, Ill.

Circle No. 7185 on reply card, p. 148.

FOR WALLS AND TOP SURFACES, the "ultimate in plastic laminates,"

(Continued on page 210)



Barcol®

OVERdoors

now feature weatherproof flush sections with house-wall insulation value!

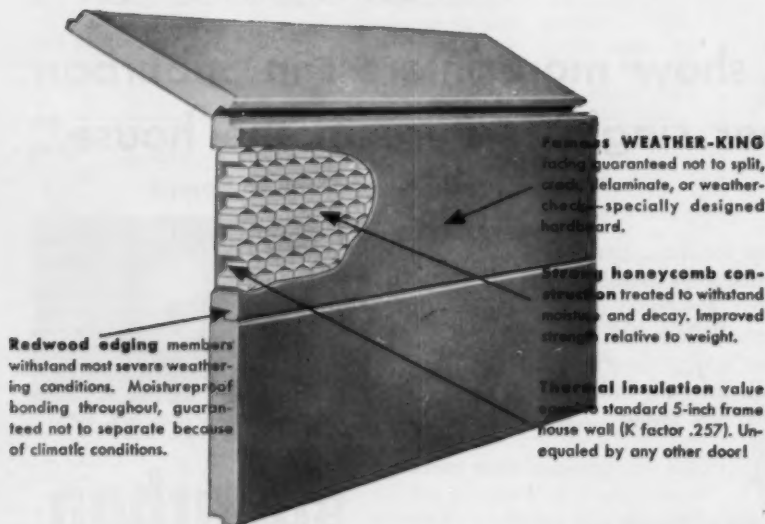

Now a flush door guaranteed against weather and with the insulating properties of a standard house wall! Combines with Barcol cam action snug closing to improve year-round comfort, cut cooling and heating costs.

Moistureproof, decayproof, verminproof, and fire-resistant, WEATHER-KING flush sections free architect, engineer, and builder from practically all limitations on use of attractive flush doors for residential, commercial, and industrial jobs. Yet the price is actually less than for most hollow-core doors! Shadow box window inserts and "Doornaments" can be used as with any flush door. Call your Barber-Colman distributor (under "Doors" in phone book) or write:

Barber-Colman Company

Dept. Q67, Rockford, Illinois



Unexcelled for sales results!

10th Annual Home and Home Furnishings Fall Festival

September 16
-October 7

AGAIN this Fall you have the opportunity to cash in on Chicago's biggest home event! Again for the 10th straight year, the Chicago Tribune will help stage the promotion that is unexcelled for producing sales of new homes, home building equipment and home furnishings and for developing peak interest in home design and financing.

Last Fall's Festival drew over 1,000,000 visitors to its dramatic community-wide showing of 91 model homes. These prospects sent Chicagoland sales of homes and home merchandise soaring. The 1956 Festival will bring

prospective homeowners out in force again to see and shop for everything you have to sell.

This is your chance to move in on a proved promotion for the home building industry. For important extra Fall volume, plan now to participate. Get in touch with a Tribune representative and let him show you how to take full advantage of the 1956 Home and Home Furnishings Fall Festival. Write, wire or phone today.

Chicago Tribune
THE WORLD'S GREATEST NEWSPAPER

favorite feature for modern living

BURR-SOUTHERN* BUILT-IN BARBECUES

COMBINING QUALITY CONSTRUCTION,
MODERN DESIGN, MODERATE PRICE



**BURR
ADJUSTAFIRE**

Model A300, designed for pit-type installation. Adjustable firebox with stationary chromed grill. Black or bronze hammertone enamel. (Spit optional.) No installation required . . . merely sets into opening.

*Originators of built-in barbecues

DELIVERY MADE WITHIN 14 DAYS.

WRITE US FOR DETAILS.
DEALER INQUIRIES INVITED.

FREE BARBECUE PLANS ON REQUEST.

BURR-SOUTHERN
CORP. OF CALIF. • 241 N. Allen, Pasadena, Calif.

MULLER MACHINES

combine
high quality with
low price

Customers often express surprise that Muller Mixers and Power Trowels of such excellent quality can be sold for such low prices. There are four reasons: (1) long experience (46 years), (2) specialization, (3) best materials, (4) best distributors.



**PLASTER and
MORTAR MIXERS**

Five sizes, 2 to 10 cu. ft. Electric or gasoline. Muller Lifetime Paddle Shaft Seal. Power throwouts on smaller models, disc clutch on larger. Rubber scraper blades optional.



CONCRETE MIXERS

Three models, 3 to 6 cu. ft. tilting type. Ample drums, fast mixing action. Timken Bearings, electrically welded construction. Electric or gasoline.



POWER TROWELS— Sizes 24", 29", 34" and 44" dia., B & S Engines. Stationary guide ring. Clutch and speed controls on handle.

Ask for prices and name of local dealer. You will be agreeably surprised with Muller's low prices.

MULLER MACHINERY COMPANY, Inc.
Metuchen 4, N.J. Cable Address MULMIX

THE *Fleettlite* Rhapsody in Glass



SLIDING WINDOWS



SLIDING DOORS



DOUBLE, DOUBLE HUNG WINDOWS



JALOUSIE WINDOWS

Glass — bringing light, vision, beauty to our new construction is offered by Fleet in matching frames of extruded aluminum. Engineering has solved the problems of weathertightness and ease of ventilating. Good design has made it practical to mix different styles in the same building.

Now you can have complete freedom and use sliding glass doors, either double hung or horizontal sliding windows and as a special feature a Jalousie window or door.

All Fleettlite products meet the needs of northern winters and western dust storms.

Write today for complete information.



FLEET OF AMERICA, INC.

2009 Walden Avenue, Buffalo 25, New York

Catalogs . .

(Continued from page 203)

Lamidall, is described in a four-page, four-color pamphlet. Color and pattern selection, structure features, applications included in brochure. Available from Woodall Industries Inc., Lamidall Div., Dept. AB, 3500 Oakton St., Skokie, Ill.

Circle No. 7186 on reply card, p. 148.

CONSTRUCTION SPEEDED with use of portable electric generating plants told in a four-page, two-color folder by Onan Electric. Brochure pictures entire new line of air-cooled generators in both single- and two-cylinder models. Technical data, features, "on-the-job" photos included in Form A-406. From D. W. Onan & Sons Inc., Dept. AB, Minneapolis, Minn.

Circle No. 7187 on reply card, p. 148.

RANCH STYLE fixtures that pull down and are adjustable offered by Markel in a four-page, illustrated catalog. Fifteen different styles shown together with size and features, all of polished brasstone texture. Markel Electric Products Inc., Dept. AB, Buffalo 3, N. Y.

Circle No. 7188 on reply card, p. 148.

CUTTING CHIMNEY COSTS explained in an illustrated booklet by General Products. Gives job-tested facts on ways to eliminate operations in chimney construction, save materials, cut down on labor time. Full descriptions of packaged chimneys. From General Products Co. Inc., Dept. AB, Fredericksburg, Va.

Circle No. 7189 on reply card, p. 148.

NEW POWER SAW by Keller, a Jefferson "601" power hack saw described in bulletin, Form 10-55. Larger saw will take 4"x4" square members or 4" O.D. rounds and pipe and will also angle cut up to 4"x4." Available from Sales Service Machine Tool Co., Dept. AB, 2363 University Ave., St. Paul 14, Minn.

Circle No. 7190 on reply card, p. 148.

GAS APPLIANCES from Empire Stove in a series of literature which covers floor furnaces, circulator heaters, recessed heating units, winter air conditioners, summer air conditioners, ducts and cooling towers. All available from Empire Stove Co., Dept. AB, Belleville, Ill.

Circle No. 7191 on reply card, p. 148.

THERE'S PLENTY MORE ON REMODELING . . .
SEE PAGES 73-103, 149-199

Three Things Happened

WHEN THIS HOUSE

WAS REMODELED WITH RUBEROID SIDING AND ROOFING

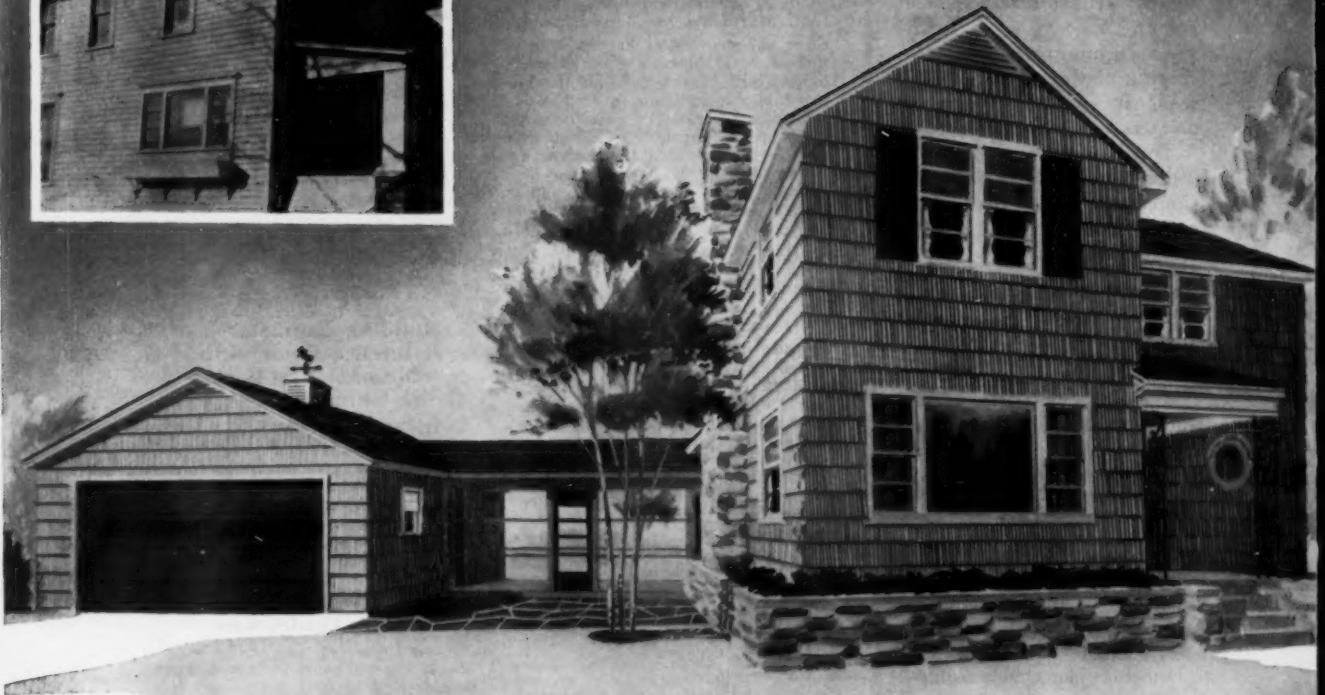

1 An Old House Got
A New Face

2 A Family Got A
Better Home

3 And A Builder
Made A Profit

No remodeling job is complete until the house is wrapped in a beautiful new exterior. It's easy to sell homeowners on adding new roofing and siding when you point out: first, no matter how much is done to modernize inside, it will still look like the same old place if the outside's the same . . . second, a new exterior "face" is easy and economical to add while you're on the job.

To make your recommendation doubly appealing, suggest Ruberoid Autoclaved Siding for beauty, and Ruberoid Lok-Tab Roofing for protection. Ruberoid Siding offers a wide range of colors . . . means longer-lasting beauty because of Ruberoid's exclusive Duroc® finish. Lok-Tab asphalt shingles offer Ruberoid's "hidden tab" design that locks each shingle down flat, protects roof from wind damage. Ask your Ruberoid dealer for the new consumer booklet — "How To Modernize Your Home." It's a natural for clinching more jobs.

The **RUBEROID** Co.

ASPHALT AND ASBESTOS BUILDING MATERIALS

NEW REVIEWS

A GUIDE TO HOME LANDSCAPING. Donald J. Bushey. McGraw-Hill Book Co. (New York) 1956. 293 pp, illus. \$4.95.

Although this book was primarily written for the home owner, it contains so much practical information on landscaping that any builder who reads it will gain valuable pointers.

The basic plans and procedures outlined are not only simple and easy to follow but can be adapted to many different situations.

THE ART OF HOME LANDSCAPING. Garrett Eckbo. F. W. Dodge Corp. (New York) 1956. 278 pp, illus. \$5.95.

The builder or home buyer who cannot afford either costly mistakes in planning or hiring a competent landscape architect will learn much from this book.

How to plan, build and plant to achieve useful and attractive outdoor space for living is enthusiastically discussed.

Drawing plans, scheduling work and money, foundations, walls, enclosures, screening, drainage, soil conditions, solar orientation, weather conditions are only a few of the subjects covered.

MOTELS. Geoffrey Baker & Bruno Funaro. Reinhold Publishing Corp. (New York) 1955. 264 pp, illus. \$12.

Everything from how to choose a site to planning a motel unit is thoroughly covered in this book. No detail is spared.

Lighting, site plan variety, heating and air conditioning, sound proofing, laundries, play areas and parking are some of the problems the authors solve.

Over 600 photographs and plans illustrate the best motels in the country.

► GENERAL REFERENCE

Simplified Carpentry Estimating

by *J. Douglas Wilson and C. M. Rogers*

Clear explanations of how to take off from a set of blueprints and specifications a bill of materials for the construction of a frame house. Arithmetical methods of accurately estimating and cross-checking against mistakes. Suitable for use of small contractors and lumber dealers. Widely adopted as a textbook for students. 5th edition. Pocket size. 304 pages. 123 illus. 60 tables. (#105) **\$3.75**

Time-Saver Standards

by *the Editors of Architectural Record*

Of great utility to the architect and builder and many other technicians. A standard reference work kept up-to-date since its inception. Large page format, 8½ x 11, shows charts and illustrations in high legibility, along with text descriptive of every detail of building practice from site planning and functional elements to the latch on the door for all types of structures. May be inspected on our approval plan. 884 pages. (#101) **\$12.50**

Richey's Reference Handbook

by *H. G. Richey*

A working reference for builders, contractors, architects, building materials dealers, carpenters, and building construction foremen. Conveniently arranged for easy use. Among its complete coverage of topics are waterproofing, building stones, fireproofing, paperhanging, plumbing, heating and ventilation, electric wiring, hydraulics. Has glossary of engineering, architectural, and trade terms. 1,640 pages. 544 illus. (#103) **\$9.95**

Legal Cases for Contractors, Architects and Engineers

by *I. Vernon Werbin*

Points out rights and liabilities and the more common trouble spots in construction, engineering, and architectural contracts and in general how to protect your interests when entering into a contract and how to avoid legal difficulties. 5½ x 8. 453 pages. 1956. (#107) **\$6.00**

Contractor's Material List and Labor Cost Estimate Forms for Home Building

A 15-sheet set of take-off forms for complete listing of material and labor coats involved in the construction of a house. (#108) **\$1.00**

Specifications Kit for Home Building

Simplified specification forms, which when properly filled out describe all materials, construction details, and quality of workmanship to be used in the erection of a home. Set of 14 different sheets. (#109) **50¢**

Handbook of Building Terms and Definitions

by *Herbert R. Waugh and Nelson L. Burbank*

A dictionary which includes also architectural symbols, plumbing symbols, pipe fittings, geometric figures, and an illustration of the 100 principal parts of a house. 421 pages. Illus. (#110) **\$5.00**

Building Estimators' Reference Book with Additional Vest-Pocket Size Estimator

by *Frank R. Walker*

Latest estimating and cost data on everything that goes into a house, apartment, or institutional, commercial, or industrial project. Fully indexed. 12th ed. 1,774 pages. Vest-pocket size Estimator, 220 pages, free with Reference Book. (#104) **\$12.00**

Hogg's Wage Tables for Building Contractors

A complete set of wage tables worked out by quarter hours for any length of time from 1 to 60¾ hours, and every wage rate from 75¢, increasing 2½¢ per hour to \$5.00 per hour. It also includes all odd rates in cents and quarter cents. Pocket size, flexible, loose-leaf bound. (#102) **\$6.00**

► CARPENTRY

House Construction Details

by *Nelson L. Burbank*

Drawings and photographs explain each detail step by step from foundation to finish. Tells how to alter stock plans and remodel as well as build new construction. 80 additional full-page drawings of house details. Conforms to national building regulations. 8½ x 11. 395 pages. 2,100 illus. (#112) **\$4.95**

House Carpentry and Joinery

by *Nelson L. Burbank*

5th edition. Latest accepted building methods for all phases of carpentry in and around the house. Contains clear details on house plans, excavations, foundations, roofing, stairs, hardware, built-in equipment, finishing, etc. Used by many schools as a textbook. 8½ x 11. 225 pages. (#111) **\$4.75**

buying . . . building . . . selling

Fundamentals of Carpentry

by *W. E. Durbahn*

Volume I—Tools, Materials, Practice (with glossary of Carpentry Terms). 374 pages. 234 illus. New 1956 ed. (#113) **\$3.95**

Volume II—Practical Construction, 512 pages, 318 illus. New 1956 ed. (#114) **\$4.95**

Complete house carpentry in two volumes. An outstanding value. 5½ x 8¼. The 2 volumes **\$8.50**

Remodeling Guide for Home Interiors

by *J. Ralph Dalzell*

How to improve the interior appearance of the home and make better use of space. 9 x 6½. 339 pages. 6 blueprints. Index. Illus. 1956. (#150) **\$4.95**

Steel Square

by *Gilbert Townsend*

Fundamentals plus step-by-step house construction problems as solved by proper use of the steel square. 5½ x 8¼. 172 pages (#117) **\$2.50**

Stair Building

by *Gilbert Townsend*

Fully illustrated guide to design and construction of stairs. (#116) **\$2.95**

▶ CABINETMAKING

How to Build Cabinets for the Modern Kitchen

by *R. P. Stevenson*

Over 70 fine detailed working drawings with materials lists and building details. A professional book for the builder or renovator. 7½ x 10¾. 246 pages. (#119) **\$4.95**

How to Make Built-In Furniture

by *Mario Dal Fabbro*

Instructions for constructing over a hundred contemporary built-ins. Pieces are included for living rooms, kitchens, playrooms, attics, and cellars. Sequence plans and illustrations. 7¼ x 9¾. 288 pages. 1955. (#123) **\$6.95**

How to Make Your Own Furniture

by *Henry Lionel Williams*

Furniture building, including chapters on setting up shop, choosing tools and equipment, selecting the correct wood, finishing, and designing of furniture. Detailed drawings, instructions, and lists of materials with dimensions for a wide variety of pieces. 179 pages. 240 illus. (#120) **\$3.95**

▶ MASONRY

Masonry Simplified

by *Dalzell and Townsend*

Volume I—Tools, Materials, Practice. Information on materials, mixes, tools and their use and care; clay tile, brick, sidewalks, drives, floors, steps. 367 pages. 210 illus. (#121) **\$5.00**

Volume II—Practical Construction. Building forms, footings, foundations and waterproofing, beams, lintels, columns, chimneys, fireplaces, walls, septic tanks. 405 p. 257 illus. (#122) **\$5.00**

Art of Bricklaying

by *J. E. Ray*

Basic bricklaying job instruction. Many illustrations, glossary, special scaffolding and cement block chapters. 5½ x 8½. 240 pages. (#130) **\$4.00**

Bricklaying Skill and Practice

by *Dalzell and Townsend*

Technique and facts of bricklaying for the mason, the student mason, and the builder. 2nd revised ed. 1954. 5¾ x 8¼. 195 pages. Illustrated. (#125) **\$3.50**

Concrete Block Construction for Home and Farm

by *J. Ralph Dalzell and Gilbert Townsend*

Planning and building the economical concrete block structure. 5¾ x 8¼. 216 pages. 151 illus. (#124) **\$3.25**

The Art of Tile Setting

by *Erwin W. Carls and Lyle G. Wines*

Procedures in setting tile, with background of materials and tools necessary. Covers development in new tiles such as aluminum with baked enamel finish, steel, cement with terra cotta surface, plastics, and ceramic tile, with simplified methods of installing every kind. 224 pages. 129 illus. (#127) **\$3.75**

▶ PAINTING

Painting and Decorating Craftsman's Manual and Textbook

Sponsored by the *Painting and Decorating Contractors of America*

Handbook for journeyman painters and apprentices. Includes also chapters on wallpaper and fabric wall coverings and glossary of trade terms. Pocket size. 430 pages. (#128) **\$2.00**

Practical Estimating for Painters and Decorators

by *William P. Crannell*

A textbook in two parts: (1) arithmetical processes; (2) estimating. Problems arranged in order of difficulty, beginning with simple floor areas, followed by walls, ceilings, baseboard, openings, etc. Pocket size. 168 pages. 1948 edition. (#126) **\$2.00**

▶ PLASTERING

Plastering Skill and Practice

by *F. Van Den Branden and Mark Knowles*

A modern book for both the journeyman and the novice. Among newer materials and methods described are sound-deadening acoustic plasters, machine process of plaster application, coating of steel members with plaster. 5¾ x 8¼. 298 pages. Fully illustrated and indexed. (#129) **\$4.90**

▶ PLUMBING

National Plumbing Code

by *V. T. Manus*

Illustrative interpretation of the National Plumbing Code. Of interest to builders, master and journeyman plumbers, and others allied. 188 pages. 200 illus. 1956 ed. (#131) **\$4.00**

How to Design and Install Plumbing

by *A. J. Mathias Jr. and E. Smith Sr.*

Study of plumbing design, installation, fixtures, drainage, sewage, water supply, and typical specifications of system in an actual house. 5¼ x 8¼. 444 pages. 406 illus. and tables. Blueprints. 3rd ed. (#133) **\$4.25**

▶ ELECTRIC WIRING

Westinghouse Home Wiring Handbook

by *A. C. Bredahl*

Guide for planning the wiring of moderate-priced homes, with emphasis on safety, effectiveness, and efficiency. Pocket size. 142 pages. 4th ed. 1955. (#132) **\$1.00**

Interior Electric Wiring and Estimating—Residential

by *Uhl, Dunlap, and Flynn*

Text and workbook on house wiring and estimating. 5¾ x 8¼. 326 pages. Fully illustrated. (#135) **\$4.25**

TURN TO PAGE 214 FOR MORE BOOKS AND COUPON FOR ORDERING ▶

BOOKS

For better planning . . . buying . . .
building . . . selling

▶ ACOUSTICS

Acoustic Principles— Practical Application

by D. J. W. Cullum

A key to acoustic problems. Important constructional features are selected for analysis, with common acoustical faults pointed out as well as those features which have given satisfaction. Treats noise reduction, isolation, amplification, reverberation, vibration, insulation; floors, ceilings, walls, partitions, doors, windows; machinery isolation. 200 p. Edition of 1955. (#139) **Only \$2.00**

Home Air Conditioning

by G. J. Stout

A 1956 book recommended to professional builders, conditioning dealers, owners, and technicians. A readable and instructive coverage of the subject. Chapters such as Planning for Air Conditioning in New Homes, Installing in Homes Already Built, Combining Heating and Cooling Systems, Humidity and Condensation Problems, Central Air Conditioning Systems, Secondary Benefits From Air Conditioning. 6 x 9. 276 pages. (#134) **\$4.95**

Heating, Cooling, and Air Conditioning Handbook

by H. P. Manly

Working and reference manual for selection, installation, and maintenance of heating, cooling, or air-conditioning equipment in buildings of all but the largest sizes. Includes 64 tables and charts with 6 pages of various regional conditions. 4 3/4 x 7 1/4. 758 pages. 1947 ed. (#136) **\$4.00**

Steam and Hot Water Fitting

by W. T. Walters and
B. E. Ferrell, Jr.

Selection, design, and installation of steam and hot water systems. Chapters include Tools, Pipe and Fittings, Boilers, Steam Systems, Hot Water Systems, Radiant Heating. 5 1/2 x 8 1/4. 239 pages. 211 illus. (#138) **\$3.00**

▶ COMMERCIAL STRUCTURES

Motels

by Geoffrey Baker and
Bruno Funaro

An up-to-date book for everyone concerned with the fast-growing motel field. Hundreds of photos and plans credited to 112 architects, designers, and other sources make this a stimulating book. Such factors as lighting, heating, air conditioning, sound-proofing, site planning, parking, pools and play areas, furnishings, laundries, restaurants, also are included. 9 x 12. 264 pages. 1955. (#148) **\$12.00**

▶ LANDSCAPING

A Guide To Home Landscaping

by Donald J. Bushey

Guide to landscaping property for maximum use and enjoyment, including site and house location, drainage, drives and sidewalks, lawns and other plantings. 288 p. 6 x 9. Illustrated. 1956. (#151) **\$4.95**

▶ ARCHITECTURAL

Climate and Architecture

by Jeffrey Ellis Aronin

All the elements of climate are described in full, acquainting the reader with the limitations that are imposed on buildings by climate—sun, temperature, wind, precipitation, lightning, humidity—and their control through orientation and planning. A well-planned and beautifully printed book including 55 tables and 300 illustrations presenting problems and solutions clearly and logically. 9 x 12. 304 pages. (#144) **\$12.50**

An American Architecture

by Frank Lloyd Wright;
edited by Edgar Kaufman

A beautiful volume that will be highly prized by all who enjoy the works of this famous architect, teacher, and personality. 9 1/4 x 12 1/4. 269 pages. 250 illus. (#145) **\$10.00**

▶ DRAWING

Architectural Drawing for the Building Trades

by Kenney and McGrail

Practical drawing instruction for builders, contractors, draftsmen, and students, demonstrated by drawings, explanations, and instructions. 8 3/4 x 12. 128 pages. (#141) **\$4.80**

▶ BLUEPRINT READING

Blueprint Reading for the Building Trades

by J. E. Kenney

A basic book that explains what blueprints are, how they are drawn, how used. Drawings designed for use in building technology courses, with question-and-answer approach. 9 x 12. 160 pages. 2nd Edition, 1955. (#140) **\$4.75**

Blueprint Reading for Home Builders

by J. Ralph Dalzell

How to visualize and read blueprints in a way helpful to builders and their mechanics, and to realtors, homeowners, and all concerned with the erection, improvement, and repair of buildings. Instructively progresses through the reading of three complete sets of working drawings. 9 x 12. 138 pages. 1955. (#142) **\$5.50**

▶ HOUSE PLANS

American Builder Blueprint Homes

Blueprints of working drawings of "Blueprint Houses" as illustrated and described in *American Builder* magazine from month to month. (#147)

Shipped by first-class mail
Per set of 1 house **\$15.00**
2 sets **25.00**
Each additional set
over 2 **5.00**

Homes for Living— House Plans

by Samuel Paul

Architect's sketches and detailed floor plans of over 75 ranch, contemporary, Cape Cod, split-level, and colonial styles. Houses are grouped into 3 price categories according to the family income. Plans and specifications for these houses are available from the architect. 8 1/2 x 11. (#143) **\$3.95**

Western Ranch Houses

Sunset

Pictorial descriptions and ground floor and site drawings. (#146) **\$3.00**

Books ordered with this coupon may be had with 10-day return privilege if requested with order and returned in undamaged salable condition.

AMERICAN BUILDER BOOK SERVICE, 30 Church St., New York 7, N. Y.

Send books indicated by circled numerals. I enclose \$
including 10¢ per book postage. (Be sure you have circled proper stock number)

101 102 103 104 105 106 107 108 109 110 111 112 113
114 115 116 117 118 119 120 121 122 123 124 125 126
127 128 129 130 131 132 133 134 135 136 137 138 139
140 141 142 143 144 145 146 147 148 149 150 151 152

Name

Address

Town, Zone, State AB 7-56



SORRY JENKINS
 — CAN'T POSSIBLY DO ANYTHING NOW —
 MAYBE IF YOU'D TOLD ME YOU WERE FIGURING IT SOONER —

YIKES! THE OLD MAN IS TURNING DOWN YOUNG JENKINS— STILL FIGURES HE'S A SMALL OPERATOR. HELL NEVER COME BACK TO US AGAIN!

YOU SAID IT! THINGS CHANGE FAST IN THIS BUSINESS. GOSH, IF WE USED DODGE REPORTS WE'D KNOW WHO WE SHOULD PLAY ALONG WITH NOW— AND WHERE TO GO WHEN WE CAN HANDLE MORE WORK.

WANT TO KNOW HOW DODGE REPORTS CAN HELP YOU SELECT JUST THE JOBS YOU WANT? SEND COUPON TODAY.

IF you have a stake in new construction anywhere in the 37 eastern states, Dodge Reports will tell you what's coming up, whom to see, what the job requires, when bids are due, who gets the contract. They give you all the information you need to sell, to plan ahead, to pick and choose the jobs you want. Whether you want *more* business, *better* business, or *more* time to handle what you have, you can use Dodge Reports with profit.

F. W. Dodge Corporation
 Construction News Division
 119 West 40th Street
 New York 18, N. Y. Dept. AB-756

Please let me see some typical Dodge Reports for my area. I am interested in:

Houses
 General Construction
 Engineering Projects

Area _____

NAME _____
 COMPANY _____
 ADDRESS _____

Yes, '56 is the year to fix



MORE SIDEWALLS... MORE ROOFS... MORE INTERIORS

... count on Flintkote Building Materials to help build up your home improvement profits!



HOME IMPROVEMENT SUGGESTION NO. 1
Give Tired Old Houses A New Lease On Life ...with FLINTKOTE INSULATING SIDING

It's no secret that home-owners the country over want their homes to have new beauty and economy. What a profit opportunity for you . . . for thanks to a special Flintkote back coating, you can offer your customers colorful insulating siding that has dimensional stability in all kinds of weather.

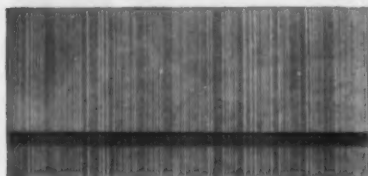

HOME IMPROVEMENT SUGGESTION NO. 2
Make Old Homes Look Like New ...with FLINTKOTE ASBESTOS SIDING

You have the edge over competition when you use Flintkote Asbestos-Cement Siding! For only in this Flintkote siding can you offer the protection of Flintkote's new "Wrap-Around" Dura-Shield* Coating . . . a coating with a face shield of silicone for added protection against moisture and staining.



HOME IMPROVEMENT SUGGESTION NO. 3
Top Off A House Beautifully ...with FLINTKOTE ASPHALT SHINGLES

The first thing on many a home-owner's list of home improvements is a new roof. Make it a FLINTKOTE roof and your selling job will be easier. You'll make a profitable customer . . . for life. Flintkote Asphalt Shingles come in a wide variety of colors and distinctive styles.



HOME IMPROVEMENT SUGGESTION NO. 4
Brighten ANY Room In The House ...with FLINTKOTE DECORATIVE INSULATION BOARD

Here's a big source of extra profits! Make use of the smart decorator colors and lovely modern textures to cheer up drab surroundings . . . reduce noise . . . add insulation.



HOME IMPROVEMENT SUGGESTION NO. 5
For Really Effective Insulation ... use FLINTKOTE INSULATING WOOL



Flintkote Insulating Wool, made of Fiberglas**, is quickly and easily installed in new and old houses. Available in handy sizes and forms. Insulating wool is clean and light in weight. Will not rust, rot or mildew. Won't attract vermin . . . fire-resistant.

HOME IMPROVEMENT SUGGESTION NO. 6



Smarten appearance...and soak up noise...with FLINTKOTE 12" Perforated Ceiling Tile. And pocket another profit.

THE FLINTKOTE COMPANY, Building Materials Division, 30 Rockefeller Plaza, New York 20, N. Y.

*Trademark of The Flintkote Company
**Manufactured by Owens-Corning Fiberglas Co.

Remember, when customers talk of home improvement... recommend Flintkote Building Materials.



FLINTKOTE ... *Style and Color Leader since 1901*



sweeping the nation!

**A REVOLUTIONARY NEW LOW-COST WAY
TO HEAT HOMES BETTER!**

International WALL FURNACE

This attractive, new, low-cost International heating unit panels simply and snugly into a wall. Easily and quickly installed at a low, low cost, the Model R-70 oil furnace is the ideal heating unit for every size home.

SAVE UP TO 65% ON YOUR HEATING BUDGET . . .

Installation costs no more than a space heater. Due to its special design, the R-70 can be converted to distribute heat overfloor, underfloor or a combination of both. Overfloor heating produces a blanket of warm air that flows constantly into the room sweeping across the floor from the bottom of the unit. Simply add ducts for conversion to underfloor system (see illustrations).

(A) Simple Overfloor System: An installation of this type requires a central furnace location with free openings to all rooms.

(B) Combination Underfloor and Overfloor System: Better heating can be had by ducting heat directly to those rooms not located adjacent to furnace.

(C) Underfloor Radial System: This is the simplest form of perimeter heating.

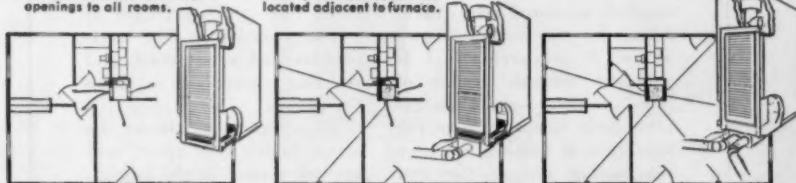

**MODEL
R-70**

ZONE HEATING IN LARGE HOMES with two R-70 units—During the day the heat in bedrooms and other areas not in use can be lowered. Then, at night when only the bedrooms are occupied, the heat in kitchen, living and dining areas can be turned down. This "zone control" results in big savings on fuel bills.

LOOK AT THESE FEATURES

- Automatic Wall Thermostat
- Full 600 CFM Blower
- Fits Snugly into the Wall—Only the Handsome Louvered Door is Exposed
- Cabinet has baked Enamel—Willow Finish

Get prices, information and detailed heating layouts of typical floor plans! Write, wire or phone today!

International OIL BURNER CO.

Originators of PERIMETER HEATING for HOMES • Manufacturers of HOME OIL and GAS FURNACES,

OIL SPACE HEATERS, MOBILE HOME HEATERS, WINDOW FANS

3800 PARK AVENUE

ST. LOUIS 10, MISSOURI

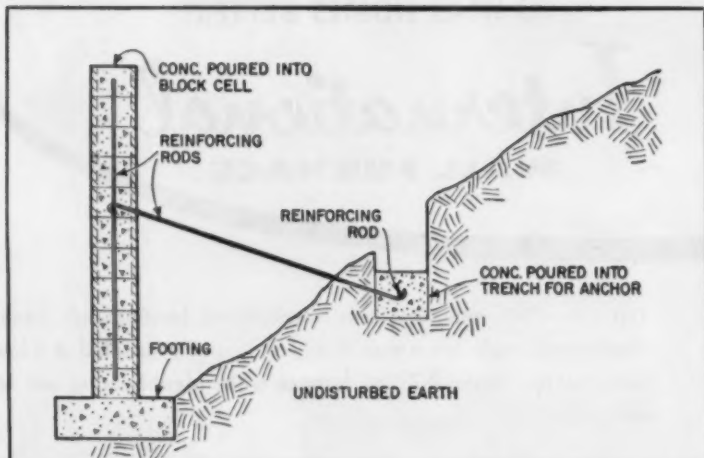

Anchor foundation before backfilling . . .

Cinder or concrete block foundation walls can be securely anchored before backfilling by the method shown above. A reinforcing rod is dropped through a line of holes in the block. Then another hole is cut in from the side three or four feet up from the footing, and another rod pushed in and hooked around the first. Concrete then is poured down through the lined up holes.

A ditch then is dug in the

earth outside the foundation, as shown. It should be about three feet long. A length of rod is placed in it, the intermediate rod is attached, and concrete poured in to make the anchor.

These anchors should be about twelve feet apart, and are not needed at the foundation corners. Six would be sufficient for the average sized foundation.

James Benton,
New Harmony, Ind.

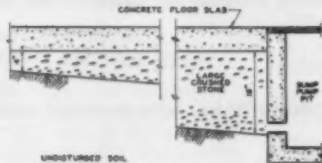

Water still follows path of least resistance

When excavating for basements in churches, schools, stores and commercial buildings, we always keep in mind the necessary pitch required to allow water to drain

without resistance to the sump pump pit.

A bed of crushed rock varying from 2 to 2½ inches in size is spread over the entire basement area prior to pouring the concrete floor. The thickness of the bed varies from 4 inches at the outside perimeter to as much as 16 inches at the bottom of the sump pump pit.

The basement floor slab is poured uniformly in thickness and pitches only where floor drains are located, but the pitch of the undis-

turbed subgrade soil is such that all seepage water finds its way to the sump pump pit, where it is automatically removed.

Eisenreich Const. Co.,
Seymour, Wis.

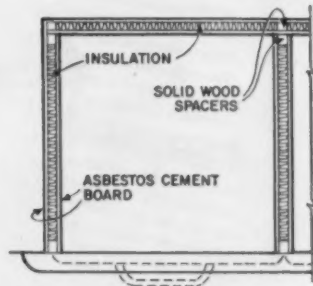

Insulating built-in ovens

Built-in wall ovens are becoming increasingly popular both in new houses and remodeling jobs. Here is one suggestion on how a quality installation should be made.

On the sides, top and bottom of the oven, a double layer of asbestos board is used, with wooden spacer strips. The boards should be from one to two inches apart. The air space in between is then filled with fireproof insulation. This will not only reduce the danger of fire, it will prevent hot spots in the surrounding wall, and reduce the expense of operating the oven.

Arthur M. Nelson, Kansas City, Mo.

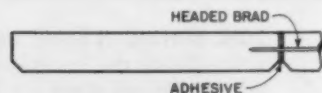

Small ceiling blocks

When acoustical ceiling blocks are being installed, it will often happen that a very small piece is necessary to fill between the last block and a hole in the ceiling, as for a light receptacle. Here is one way of handling these problematical small pieces.

A layer of the same adhesive that is being used to put up the ceiling is applied to the edge of the last complete block. Then a ripping of the correct size is put on and edge nailed with a headed brad, as shown. The result will be tight.

H. Lemaster, Carlinville, Ill.

Low-Cost
Luxury for every
home!

EDWARDS MODERNIZATION PACKAGE!

It's a natural! Edwards' Home Modernization Package adds visible luxury and modernity to any home whether new construction or remodeling... yet costs so little! Compare with any other "extra" you could add... penny for penny, it's *way* out in front!

Attractive to prospects... easy to install... and all wrapped up in one package at a special price. Add extra appeal to your homes with Edwards' Home Modernization Package. Call your Edwards Distributor today.

Here's what you get:

New Bolero 3-Way Chime:

Exclusive Vibrechord plus 2-note and 1-note gives three distinctive, melodious tones. Handsome neutral ivory finish may be painted to match any decor.

Home Fire Alarm:

The biggest low-cost feature you can put in a house! Edwards' Home Fire Alarm is a permanent fire warning system that needs only bell wire for connections between signal unit and UL-approved thermostatic detectors.

Transformer:

Edwards quality, made to last a lifetime and longer. Easy to install.

Push Buttons:

Unique, modern styling that matches the finest hardware, lasts a lifetime anywhere.

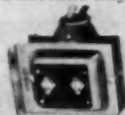
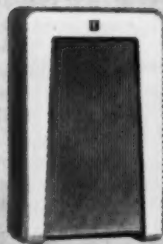

Putting up a model home? Put these features in it! Write, wire, or phone: Edwards Company, Inc., Dept. AB-7, Norwalk, Connecticut. (In Canada: Edwards of Canada, Ltd., Owen Sound, Ontario.)

EDWARDS Specialists in signaling since 1872
DESIGN • DEVELOPMENT • MANUFACTURE

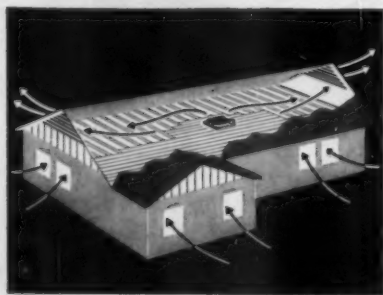

Easily Installed—The new Hunter is the simplest of all attic fans to install in any home, old or new. Fan unit rests on attic floor over ceiling opening — automatic shutter can be installed in 10 minutes. No special wiring is required other than connections.

Low-cost Operation—This fan can be operated for only a few cents a day and will last for many years, with little or no maintenance. Sizes to fit any home size and climate—certified air deliveries from 5000 to 16000 cubic feet per minute.

Write for "How to Select the Hunter Package Attic Fan to Cool Your Homes." See our file in Sweet's.



**HUNTER FAN
AND VENTILATING
COMPANY**

P. O. Box 3775-E, Memphis 14, Tenn.

AMERICAN BUILDER

How to do it better . . .

(Continued from page 218)

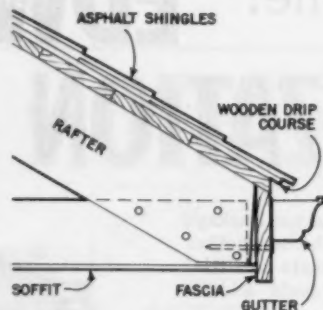

To keep fascia straight

If rafter ends are to be cut before the rafters are put in place, it is usually difficult to get an even line down the ends from one end of the house to the other. Here is a way to wind up with a reasonably even fascia.

Instead of cutting the rafter end plumb, undercut it about a quarter of an inch, as shown. The soffits, edges of which are easily cut to a straight line, are nailed up and their edges lined up so that they stick out from the bottom of the rafter end about a quarter of an inch. When the fascia board is nailed up, the bottom of it will follow the straight line of the soffit edge. Any irregularities in the top will be hidden by the drip course of shingles.

L. R. Will, Denver, Colorado

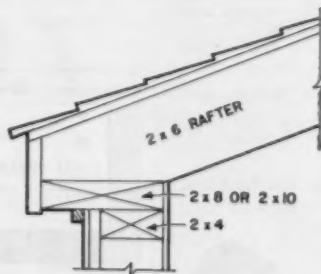

Soffit top plate

In houses with short eave overhangs, this method of cornice construction can be a real time saver.

Instead of using the usual 2 x 4 for the upper plate, use a 2 x 8 or a 2 x 10, depending on the overhang desired. The two plates are laid flush on the inside so the larger one sticks out on the outside.

Instead of a bird's mouth, the roof rafters receive an angle cut on the bottom and end, as shown. The pro-

truding upper plate now acts as a finished soffit. A fascia board is nailed to the rafter ends and the plate to complete the cornice.

N. M. Pittman, Overton, Texas

Lally column eliminates concrete block pier

A concrete block fire wall between the attached garage and house was reduced from 8 inches in thickness to 6 inches by using a 4-inch steel lally column to provide the necessary support in one spot for the balance of the house over the garage.

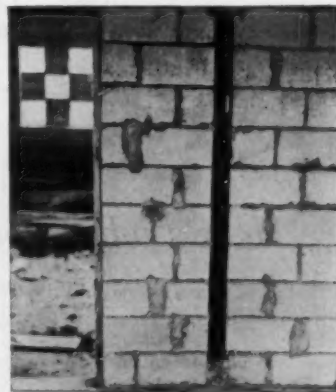

The use of the lally column also eliminated the need for a projecting concrete block pier that would have been otherwise required to support the load carried by a steel "I" beam overhead in the center of the garage. Both sides of the concrete block wall can be furred out and plastered without any further regard to the embedded lally column.

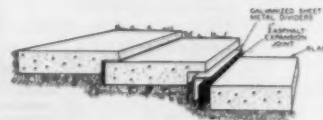

Joints for step-up walk

Invisible expansion joints can be provided for a step-up concrete walk so that each section or slab is free to move in the same direction. The galvanized angle and the asphalt expansion joint material are placed in position when the concrete is to be poured. The slab is free to move horizontally on the galvanized angle and butt against the expansion joint material the same time.

Arthur N. Nelson, Kansas City, Mo.

FREE-10 DAY TRIAL

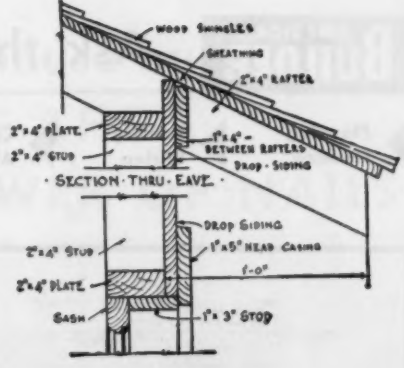
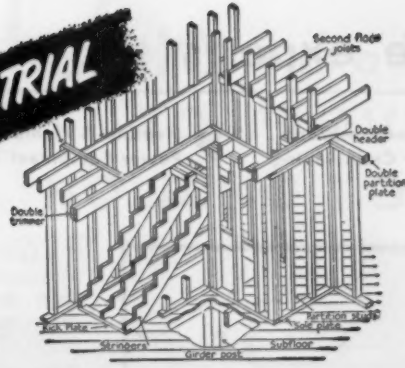

NOW Get the INSIDE TRADE FACTS on
HOUSE CONSTRUCTION DETAILS
 Save Money and Time—Get Better Construction—
 with these Professional Methods

Here, at last, is an exact working guide on every detail of house construction from foundation to finish. Tells you dimensions, materials, processes, step-by-step working methods. Hundreds of scale drawings and photographs make every step easy to follow. Can be used for alterations in a set of stock plans, for making additions or changes in a building, or for complete construction of a dwelling.

Conforms with modern practice and building regulations in all parts of the country. A book you will refer to for years! The professional guidance you get on even a single house construction detail can *repay you a hundred times the small cost* of this wonderful volume! Send for free-examination copy today. Mail coupon below.

Every Step in House Construction Explained and Illustrated

Excavations • Footings and drainage • Foundation forms • Sills • Girders • Joists • Sub-flooring • Exterior wall framing • Interior wall framing • Ceiling joists • Gable roof • Hip roof • Gambrel roof • Dormers • Siding and shingling • Cornices • Porches • Exterior walls of wood • Exterior walls of brick • Interior walls finished in plaster, in plywood • Wall panels • mouldings for interior trim • Stair construction • Windows • Sash details • Window framing details • Doors and door trim • Hardware used in dwellings • Closets, shelves, built-in equipment • Breakfast alcove • Sewing room • Flooring • Chimneys and fireplaces • Mantels and seats • Outdoor fireplaces • Scaffolds • Garages • Electric wiring • Insulation • Arches and gates • Lattice porch, lattice trellis • Garden benches, tables • Swings and other garden furniture • Picket fences • Log cabins, camps, cottages • Barns • Feeders and nests • Rabbit hutch • Septic tank • Painting and finishing • Heating systems • Air conditioning systems • Prefabricated houses •

Quick reference index enables you to find instantly any Construction detail on which you want Modern, Authoritative Guidance.

385 Pages. Size 8 1/2 x 11. Fully Indexed. 2100 Illustrations.

The "How" Book of House Construction

Nothing else like it! Other books may show you *what* to build, but this is the book that shows you *HOW* to build! Every detail in the construction of a house is clearly described—illustrated with large, easy-to-follow drawings—indexed for ready reference. Send coupon below to get your free-trial copy.

SEND NO MONEY

NEW, ENLARGED EDITION JUST PUBLISHED

Examine 10 DAYS FREE

You don't risk a penny to find out how valuable "House Construction Details" can be to you. Just mail coupon. See for yourself how you get clear, professional guidance on every building detail. Then either send only \$4.95 (plus postage) in full payment, or return the book and owe nothing. Mail free-examination coupon NOW.

MAIL THIS COUPON

Simmons-Boardman Books, Dept. AB-756
 101 Church Street, New York 7, N. Y.

Send me for 10 DAYS' FREE EXAMINATION, "House Construction Details." I will either return it in 10 days and owe nothing, or send only \$4.95 (plus shipping charges) in full payment.

Name

Address

City & State

SAVE! Send \$4.95 with this coupon and we will pay postage. Same return and refund privileges.

▶ Planning
Framing

▶ Roofing
Wiring

▶ Concrete Work
Air Conditioning

▶ Heating & Plumbing
Power Equipment

▶ Insulation
Interior Finish

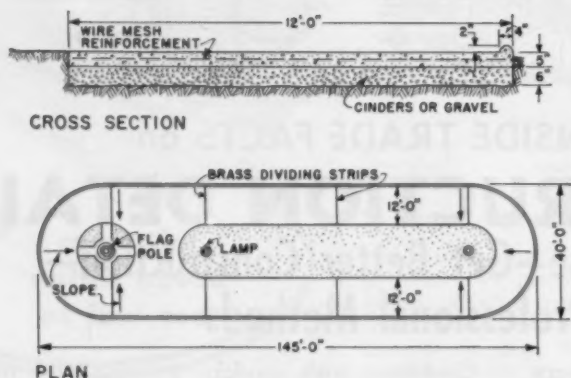

Roller rink layout; it's a circular sidewalk . . .

QUESTION: I propose to build a roller skating rink and am looking for any information I can get. Is there a standard size of such a rink? Width and length? Can cement be used for the floor and what are the proper steps to follow?

Joseph Butera
Providence, R. I.

ANSWER: The above plan and section are self-explanatory. Note that there are two slopes, end and side. Ends slope $\frac{1}{2}$ " to 1'; sides, $\frac{1}{8}$ " to 1'. Any substitute for brass divider strips should be highly weather-resistant, of course. Your concrete mix should be 1:2:3 for best results.

Wants an insulating plaster

QUESTION: I've been asked to remodel a home. The walls are plaster over thick fieldstone. If I plaster right over the present walls will I be able to stop moisture from coming through?

William Kromer
Avoca, N. Y.

ANSWER: No, it is best to remove the existing plaster. Then apply a good water-resistant plaster such as that of the Busatti Corp. of America, 52 Broadway, New York, N. Y.

Boards or solid sheathing?

QUESTION: In this area we have always installed wood shingles on 4-inch boards. Now an owner wants

me to lay shingles on solid sheathing. Please advise your findings.

Lyle Whittington
St. Joseph, Mo.

ANSWER: Nailing shingles to solid sheathing is now an accepted procedure. You get rigid framing and you also save time and materials.

Basket-weave fence

QUESTION: Could you tell me what kind of lumber to use, size and post-spacing for a basket-weave fence? What's the best way to get the weave effect?

S. M. Morreale
Jersey City, N. J.

ANSWER: Use redwood, white cedar or cypress for posts. Slats can be

1 x 4's or 1 x 6's, either regular lumber placed 6' o. c. or bark cuttings from the mill. For the latter use closer spacing for posts.

Carport roof problem

QUESTION: I am going to construct a carport about 20' x 22' in length. If I use a flat roof, will 2 x 8's, 16' o. c., on 20' spans be enough? I could use a rafter construction with a 1 to 6 pitch. What about posts?

Richard D. Shannon
Kansas City, Kan.

ANSWER: If you use a flat roof we recommend posts 4' o. c., two 2 x 10's for headers and 2' x 12' beams on 16" centers. A gable roof, however, might be more practical since it requires smaller lumber.

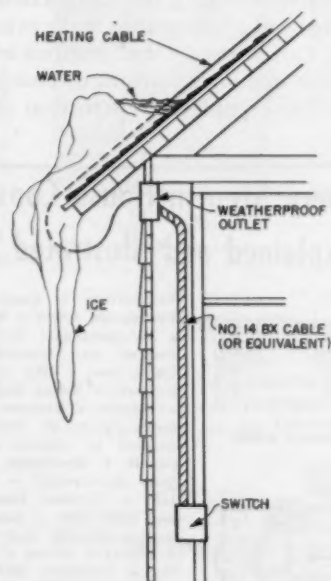

Roof dams

QUESTION: The ice that forms on the eaves of our houses is a definite safety hazard. We are in the high mountains of Colorado and get alternate thawing and freezing of snow and ice. Have tried chopping but that damages the roofs. We would like your suggestions.

Eldon V. Hallmark
Construction Supervisor
Climax, Colorado
(Continued on page 224)

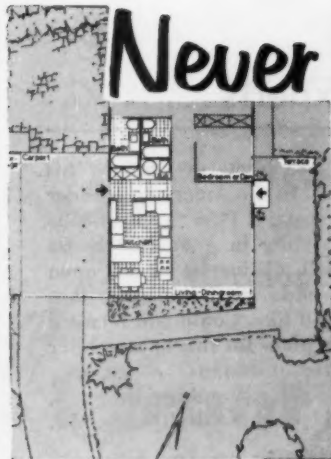

Never before was a house built TO PROVE THE HOLDING POWER OF NAILS



V. P. I. Demonstration House, Blacksburg, Va., a project of Engineering Experiment Station, Virginia Polytechnic Institute. Sponsored by Independent Nail & Packing Company; with Research Institute of NAHB, and "Living for Young Homemakers" as co-sponsors.

New and better fastening methods developed in this house will help you to build houses better

INDEPENDENT scores another pace-setting "first" with its sponsorship of V. P. I. Demonstration House—built expressly to develop better fastening methods made possible by the far greater holding power of STRONGHOLD Annular Thread and SCREW-TITE Spiral Thread Nails.

Ways to build houses better, at lower cost—improved nailing techniques, increased structural strength, fewer repairs, big savings in maintenance—will result from this "house that nails built."

Fewer nails per joint, fewer joints with consequent savings in labor and materials, upgrading of lower grades of lumber are some of the advantages forecast.

Remember—the nails used are STRONGHOLD and SCREW-TITE Nails as manufactured exclusively by us; the results cannot be applied to any other nails.

That's why it's important to ask for STRONGHOLD and SCREW-TITE Nails—by name.



Continuing reports on fastenings and fastening methods employed in the V. P. I. Demonstration House will be made by Dr. E. George Stern, Director, Wood Research Laboratory, Virginia Polytechnic Institute. We'll gladly send you reprints as fast as they become available. Ask us to put you on the list for "V. P. I. House Reports."

• **IMPROVED NAILS** have changed construction methods—and the nails that have brought about the changes are STRONGHOLD and SCREW-TITE.

• **ALL THE PROOF** of the great advances in fastening methods made possible by improved nails is the result of tests made with STRONGHOLD and SCREW-TITE Nails as made only by Independent Nail & Packing Company, and cannot be applied to nails of other manufacture.

Ask your dealer or distributor for STRONGHOLD® and SCREW-TITE® Nails by name—or write us for catalog, samples and technical data



Copyright 1956, Independent Nail & Packing Company

There is only one STRONGHOLD Line—the Original. Made only by

INDEPENDENT NAIL & PACKING CO.

Pioneer Developers and Largest Manufacturers of Threaded Nails

BRIDGEWATER, MASSACHUSETTS, U.S.A.

STRONGHOLD, THE STRONGHOLD LINE, SCREW-TITE, Trade Marks Reg. U. S. Pat. Off.

**FOREMOST SOURCE
for AREAWALLS**

SAINT PAUL CORRUGATING CO.

**IMPERIAL
Lux-Right®**

The Nation's Best

Most complete line in U.S.A. Three shapes: Streamlined-straight, Round, Square. Special sizes our speciality.



IMPERIAL LUX-RIGHT: Long recognized as outstanding for American homes. Hand-dipped galvanized after fabrication.

ECONOMY LUX-RIGHT: For medium-priced homes where price is a factor. Economy grade tight-coat galvanized.

CASEMENT: For lower floor rooms in basement, hill or split-level homes. Square type. Right angle corners let the windows open wide.

ACCESSWAY: Provides easy access under houses with no basevents. Square type lets doors swing wide open.

We prepay freight on 12 units or more. Dealers everywhere. **FREE** illustrated folder gives full details on complete line... Phone your distributor, or write us.

AB-7

SAINT PAUL CORRUGATING CO.

Expert Fabricators of Sheet Metal Products for 71 Years
SOUTH END WARASHA BRIDGE • SAINT PAUL, MINN.

LEARN TO ESTIMATE

You can estimate building construction costs quickly and accurately, and bid on profitable commercial and industrial jobs without worry about "What did I leave out?" or "Am I bidding too high, or worse yet, too low?" Become a successful building contractor by devoting some spare time to the study of our estimating course.

WHAT WE TEACH

We teach you to read plans, list and figure the cost of materials, estimate the costs of labor, and the other things that you need to know to bid on construction work with confidence. The labor cost data that we supply is not vague and theoretical—it is specific, complete, and accurate—it gives you the actual cost of labor required to do work in your locality at today's wage scales. We teach you to prepare estimates complete in every detail.

OUR GUARANTEE

Best of all you don't need to pay us one cent unless you decide that our course is what you need and want. We will send you plans, specifications, estimate sheets, cost data, and complete instructions for ten days study, so that you can see for yourself what this course can do for you. Mail the coupon today—we will do the rest.

CONSTRUCTION COST INSTITUTE

Dept. 756—Box 8788
University Station—Denver 10, Colorado

Send me your course on how to estimate building construction costs for ten days study. If I decide to keep it, I will send you \$19.75 (payable in two monthly payments) as full payment. Otherwise I will return the course, and there is no further obligation.

Name _____

Address _____

City _____ Zone _____ State _____

**AMERICAN
BUILDER**

Ask the experts...

(Continued from page 222)

ANSWER: There are several types of heating cable on the market. These may be laid in zig-zag fashion along the edge of your roof and connected to a weatherproof outlet as shown. Also available is *radiant heating cable*, which costs about three cents a foot, operates at a temperature of 130° and is waterproof.

Calculating dead and live load

QUESTION: Recently one of my home buyers asked me to explain to him the calculation of dead and live loads. I did so but not quite in the manner I would have liked to. Would you forward me in detail the methods of calculating loads? Also please advise how I can obtain the specs (size, weights and spans) on steel girders and spans for one family dwellings.

Pasquale P. La Face,
Ridgewood, N. Y.

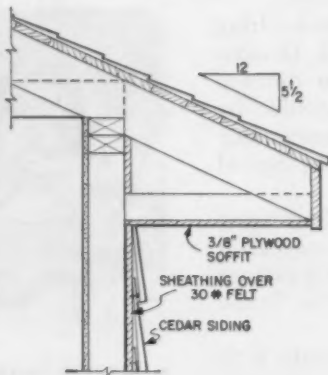

ANSWER: Dead load refers to the weight of all materials that become a permanent part of a structure, or unit thereof. Live load is weight added after the structure is completed. Tables for calculating dead and live loads are found in Ramsey and Sleeper's *Architectural Graphic Standards* or the *I C S Building Trades Handbook*. For steel girder design see page A-18 April, 1956, Directory issue of American Builder.

One Scholz open glass end, please

QUESTION: I have a sloping waterfront lot and am very anx-

ious to erect my home this spring. In the American Builder of February, 1956 "You get \$50,000 styling in a \$15,000 house... with distinctive Scholz open glass end." This is a style that I would like. Could you forward house plans for this or any other waterfront designs?

Woodrow H. Ward,
Baltimore, Md.

ANSWER: The two-story Scholz design is, as you say, ideal for a sloping waterfront. We suggest you write Scholz Homes Inc., 2001 N. Westwood, Toledo 7, Ohio. With their recently purchased plant in Wilmington, Del. they should be able to fill east coast orders soon.

Venting a kitchen fan

QUESTION: We have installed a 10" ceiling fan in a 10' x 11' kitchen. The fan just doesn't seem to be powerful enough to do the job. Would it be possible to use a vertical cabinet type fan with a hood which would be over the counter cooking units? Would it be possible to vent the fan into the attic without having to go through the roof with a jack? Would a spun glass filter prevent the grease from going into the attic?

Wesley L. Dodge, Monroe, Wis.

ANSWER: Most manufacturers of kitchen ventilating fans supply data on installation. In general, you should check with your building inspector first; some codes require fans to be vented to the outside. If you install a ventilating hood, vent it either directly to the sidewall or through the attic and out the nearest eave. For details see pages D-10 and D-18 of the April, 1956, Directory issue of American Builder.

Got a problem you can't solve? Write and "ASK THE EXPERTS." In addition to American Builder's own staff, your questions will be answered by Joseph Steinberg, head, and Martin A. Stempel, instructor, of the Construction Technology Department of New York City Community College.

the newest
outstanding
Grant
product
development



Textured,
scuff-proof,
tough,
vinyl fabric
surface

the
Grant *folding door*

A REAL DOOR THAT FOLDS!

styled by Paul McCobb



Vinyl is permanently
laminated to hard, solid
panels.



features

Solid Panels: The solid panel construction of this Grant door is a revolutionary development in a folding door at moderate price. The *Grant Folding Door* has crisp, clean lines, blocks sound, hangs rigid without billows or rustle. Knock on it. It sounds and feels like a door.

Space Saving: Frees an average of 14 square feet of floor space (19 square feet of wall space) for living space, better arrangement of furnishings.

Durable — Easy to Maintain: Vinyl surface can be wiped with a damp cloth—scrubbed if necessary. Tough and long-wearing, resists scuffing, color is permanent.

Easy Installation: Only a screwdriver is needed to install the *Grant Folding Door* in standard door openings in minutes. Readily adaptable to non-standard openings.

Decorative Flexibility: Color styled to harmonize with modern or traditional furnishings. Attractive design of handles, track and other details, also specially styled by famous Paul McCobb.

▶ Ask for your copy of fully descriptive specifications booklet, the swatch book showing the attractive colors available and texture of the non-scuffing vinyl finish.

the
Grant *folding door*

"A REAL DOOR THAT FOLDS"

Grant Pulley and Hardware Corporation
31-63 Whitestone Pkwy., Flushing 54, N. Y.
944 Long Beach Avenue, Los Angeles 31, Calif.

Other Grant Products:
Sliding Door Hardware • Drawer Slides
Drapery Hardware • Sliding Door Pocket Frames
Sheaves and Tracks • Pulls • Industrial Slides

Easy Portability with this
CHAMPION
MASONRY SAW



Champion's Tak-A-Bout masonry saw can be easily moved by one man. Put down the wheels and it rolls easily to the spot you want to use it.



A 110-220 voltage selector switch on Champion masonry saws allows you to switch currents quickly without costly shut down time for wiring.

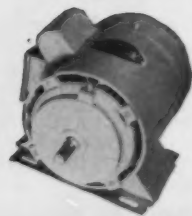

On Champion masonry saws, a fan cooled motor dispels heat, helps your operator's efficiency.

USE THIS HANDY COUPON TO SEND
FOR MORE INFORMATION . . .

CHAMPION MFG. CO.
Phone: GA 1-6202
2028 Washington Ave. • St. Louis 3, Mo.

Please send:

more information

name of my nearest dealer for
Champion Tak-A-Bout Masonry Saws

NAME

ADDRESS

CITY ZONE STATE

AMERICAN
BUILDER

KEEPING UP WITH THE LAW:

Corporate type of business best for the builder



By **JOHN F. McCARTHY**
Attorney-at-law

A question of importance for each builder is through what type of business organization he should operate. The choices include the sole proprietorship, the partnership, if more than one is interested in the business enterprise, the trust and the corporation. Even the small volume builder will find advantages in conducting his business through one type of organization when compared with another. This article is limited to a consideration of a few of the benefits to a builder in operating through a corporation.

One of the basic advantages of the corporate type of business organization is the continuity of its operation. The business entity is the corporation. It continues despite changes in the identity of its stock holders, directors and officers. Death ends the sole proprietorship and may terminate the partnership, but not so with the corporation.

A corollary to this advantage is the ease found in transferring interests in the corporation. Changes of ownership, of course, take place merely through transfers of the shares of stock of the corporation. This is easily accomplished.

A further benefit is the avoidance of personal responsibility on the part of stockholders, directors and officers, and the placing of liability solely on the corporation and its assets. The avoidance of liability on the part of the individuals and the freedom of their assets and property from corporate obligations are benefits that are well recognized. These results are accomplished by limiting obligations undertaken to

those of the corporation.

Another advantage which may follow from doing business through a corporate type of organization, is a possible reduction in federal income taxes. Here the applicable principal generally is that an increase in the number of taxpayers will divide income and reduce taxes. The division of income well may be between one or more individuals on the one hand, and one or more corporations on the other. A consideration of a builder's tax problems, and of savings in taxes which may be effected through different types of business organizations, will may be the deciding factor in the adoption for the builder of one type of business organization as against another. A simple example will illustrate the advantage in question.

Assume a builder who is a married man. His business nets \$41,000 a year. If he operates as a sole proprietor and files a joint return with his wife, he will pay an income tax of 56%. However, the rate on the first \$25,000 of corporate net income, as well as on the first \$16,000 of personal net income of a taxpayer filing a joint return, is 30%. If the business is incorporated and the builder receives a salary of \$16,000 a year, thus reducing the net income of the business to \$25,000, both the corporation and the builder will pay taxes at the rate of 30% and a saving of 26% will have been effected.

Every builder, however small, should give careful consideration to the type of business organization through which he is operating. He should be sure that it accomplishes the purposes that he desires and effects dollars and cents savings for him to the greatest possible extent.

month after month...

15½ million* men and women "live by the book" ...and the book is Better Homes and Gardens!

4,250,000 DELIVERED COPIES EACH MONTH

"Living by the Book" is no abstraction!

It's always something definite and concrete—to *do*, to *make*, to *buy*. It's Dad fixing a leaky faucet. It's Mom laying out a rose bed or planning a patio buffet supper for family and friends. It's Sis doing her room over. It's Junior dreaming about the portable outdoor barbecue Dad's been hinting at. It's a family conference on a combination *vacation-uranium* hunt first seen in the Book!



Separately and together, every member of the family turns to Better Homes & Gardens for help with today's tasks, inspiration for tomorrow's plans. That's why they refer to it, affectionately, as "the Book". It's more than a book. It's the



spark for the warm friendly fire that burns everywhere on America's hearthstones!

Isn't this the way you use it?

*15,500,000 people read an average issue of BH&G! One-third of the 123,800,000 people 10 years of age and older in the U.S. read one or more of every 12 issues. That's 44,150,000 people—and over 40% of them are men!

during the year...

1/3 of America reads Better Homes and Gardens!

Meredith Publishing Company, Des Moines 3, Iowa

*A 12-Months' Study of BH&G Readers, Alfred Politz Research, Inc., 1956

Insure your profits by using this new estimating guide...

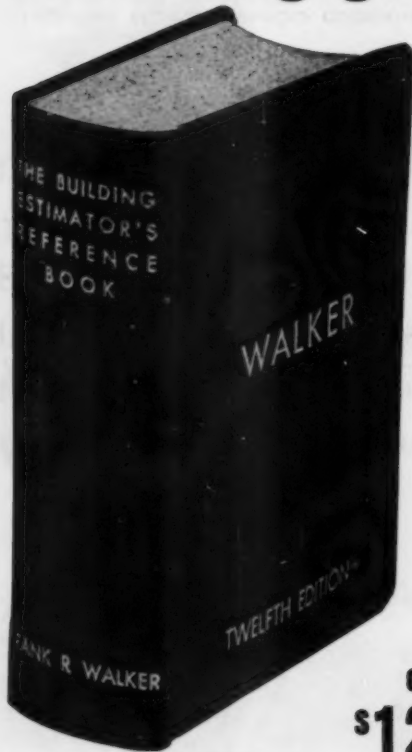

1755
pages

• Good
for any
locality

only
\$12.00
postpaid

at **NO EXTRA CHARGE** get
Companion
Vest Pocket
Estimator

The standard help for contractors and estimators. During 40 years, over 130,000 copies have been sold in its many editions. This new edition was revised

from cover to cover and includes information on new and modern materials, tools and methods. No builder can afford to be without it if he wants to compete in today's price battles, yet protect his profits.

AMERICAN BUILDER BOOKS
30 Church St.,

AB-756

New York 7, N.Y.

I enclose \$..... Send copies of Building Estimators Reference Book with a Vest Pocket Estimator for each copy ordered.

Name
Address
Town, Zone, State

If some building terms PUZZLE YOU...

BANK-RUN is not a panic.
BUS CONDUCTOR is not a fare grabber.
FISH PLATES are for beams, not breams.

... this is a book
you need!

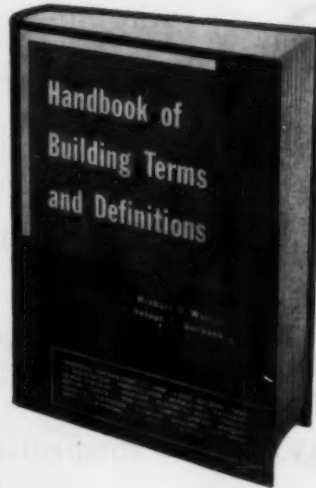

By
Herbert R. Waugh
and
Nelson L. Burbank
Former instructors in construction and building trades, Bridgeport, Connecticut and Cincinnati, Ohio schools.

422 PAGES

OVER 12,000
TERMS

HUNDREDS OF
ILLUSTRATIONS

BEING SURE of the correct meaning of any building term can often mean money to you! And with many thousands of such terms in use, **not even** the most experienced can be

positive regarding the meanings of them all. The only safeguard is to turn to an accepted authority.

Such authority may be a regular dictionary, yet not even in Webster's Unabridged will you find many of the terms which are constantly cropping up in the building industry. That is why the authors, Waugh and Burbank, who knew that they and their fellow teachers needed a specialized book of definitions, decided to compile one. Then, while talking to contractors, builders and architects about the project, it was discovered that they, too, needed it just as badly. The result is **The Handbook of Building Terms and Definitions**, product of many years of painstaking research, compilation and careful cross-checking.

The **Handbook of Building Terms and Definitions** is a compact, desk-size book approximately six by nine inches. The part of speech and correct pronunciation is given for each word. At the low price of only \$5.00 postpaid, this is a book which no one in the building industry can afford to be without. Order your copy today on the coupon below. Full refund will be cheerfully made if you are not completely satisfied that this book will prove useful.

AMERICAN BUILDER BOOKS AB-756
30 Church St., New York 7, N.Y.

I enclose remittance of \$5.00. Please send me postpaid, one copy of HANDBOOK OF BUILDING TERMS AND DEFINITIONS. I have 10 days to examine the book and, if not satisfied, can return it within that time for full refund.

Name
Address
City, zone, state

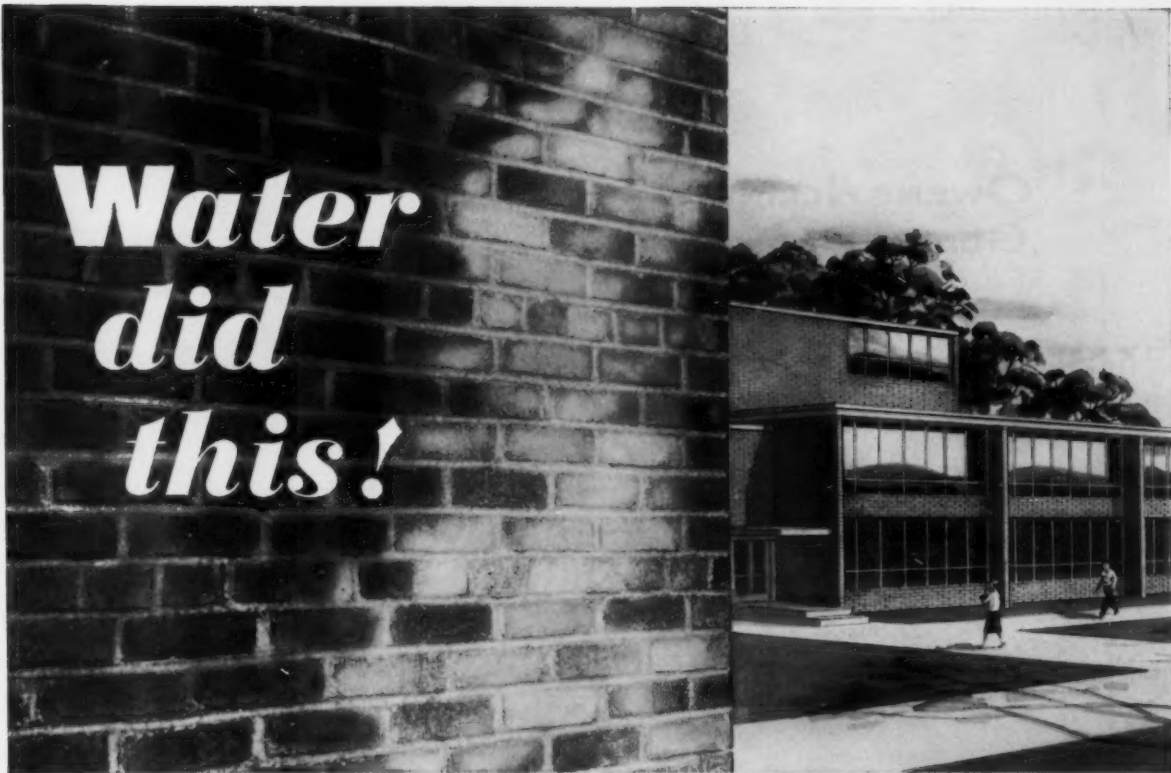

**Water
did
this!**

PRESERVE MASONRY BEAUTY

with durable G-E SILICONE "defense in depth"

This is efflorescence—unsightly white stains that come from water dissolving the salts in masonry. You can check it—through durable *silicones*. A simple, inexpensive treatment of above-grade masonry, with water repellents containing General Electric DRI-FILM® silicones, preserves masonry beauty—checks efflorescence—retards spalling and cracking. Your masonry stays cleaner, too, for water can't carry dirt or stains into the pores. And, of course, a water-repelling *exterior* means a dry *interior*.

PROVIDES "defense in depth"

A water-repellent treatment with General Electric DRI-FILM silicones is the *most durable known*—because it provides "defense in depth." Silicones actually

penetrate masonry pores—get deep inside—where they cannot be eroded away. Durable DRI-FILM silicone protection *lasts for years!*

Why not ask your supplier of water repellents about *silicone* protection for *your* masonry? For the names of suppliers using G-E DRI-FILM in their products, just write to:

**Silicone Products Department
General Electric Company**

Section 64-2B, Waterford, New York

(IN CANADA, write to Canadian General Electric Company, Ltd., Toronto.)

Paint and Chemical Manufacturers!

General Electric DRI-FILM silicones offer you a profitable opportunity to add a superior masonry water repellent to your product line. Ask us about them!



Progress Is Our Most Important Product

GENERAL  ELECTRIC

OWENS-ILLINOIS GLASS BLOCK

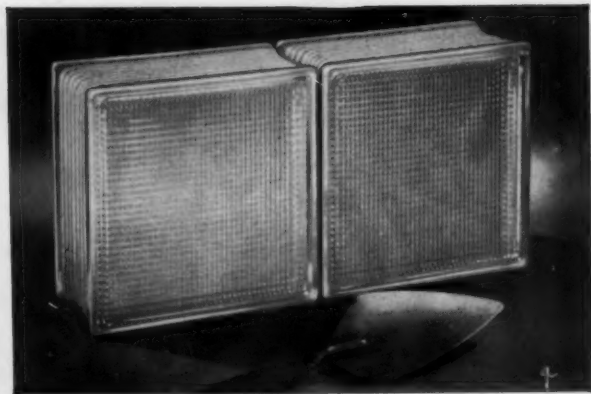
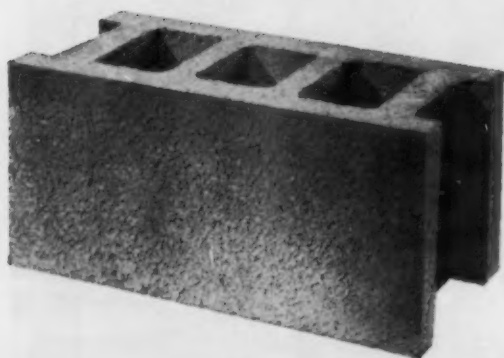

— AND CONCRETE BLOCK

*...building materials
that "belong" together*

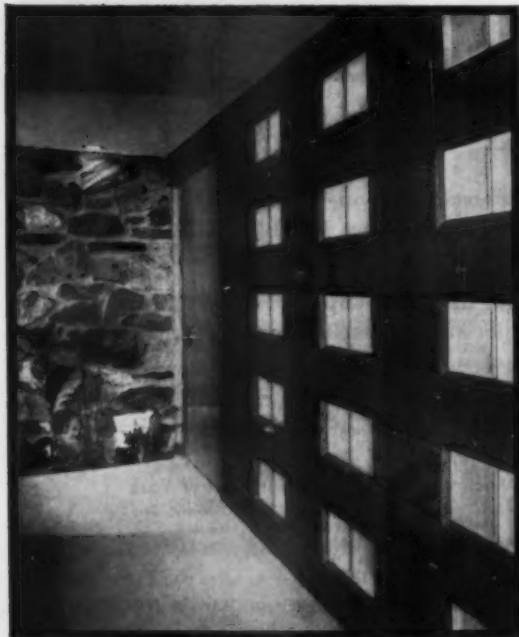

Glass block and concrete block "fit." Two 8" glass block equal a standard concrete block. When you use glass block in a side wall you have no delays in construction. They go in at the same time as the concrete block.

Owens-Illinois Glass Block are handled in the same way as concrete block and modular brick—same mortar materials and similar laying technique . . . go in at the same time.

Glass block arrive on the job site packed in sturdy cartons of convenient size. Cartons can be opened as block are needed. No loose block for you to handle. Panels can be made to fit any size opening . . . no frame is necessary. Because Owens-Illinois Glass Block have a specially designed corrugated mortar-bearing surface, you benefit from cheaper and faster masonry construction. And only Owens-Illinois Glass Block have this design feature.

To save you additional time and money, all mortar-bearing surfaces on O-I Glass Block are pre-coated with a special grit material for easier installation and all exterior faces have O-I's "magi-clean" finish for easy cleaning.

Owens-Illinois Glass Block are available in a wide variety of designs from super-clear that you can see through to those that restrict sight completely. Literature for any glass block application is available free of charge. For information or help with a specific problem write: Kimble Glass Company, subsidiary of Owens-Illinois, Toledo 1, Ohio.



OWENS-ILLINOIS GLASS BLOCK
AN **(I)** PRODUCT

OWENS-ILLINOIS
GENERAL OFFICES • TOLEDO 1, OHIO



W. F. MUNFORD

Portrait by Fabian Bachrach

"A Dynamic Potential . . ."

. . . is created daily by millions of Americans in their purchases of U.S. Savings Bonds through the Payroll Savings Plan. Better than three out of four of United States Steel's American Steel and Wire Division employees are taking advantage of this easy automatic plan of saving.

"We in management feel that every employee, whether newly hired or already on the payroll, must be advised constantly as to the values of this Savings Bond Pro-

gram. A program designed to maintain high employee participation is an integral part of our everyday operations."

W. F. MUNFORD, President
American Steel and Wire Division
United States Steel Corporation

Does *your* company present the advantages of The Payroll Savings Plan (and a Payroll Savings Application Blank) to every *new* employee? Are 75% of *your* employees enrolled in *your* Payroll Savings Plan?

Write to Savings Bond Division, U. S. Treasury Department, Washington 25, D. C. Your State Sales Director will be glad to help you take your place with American Steel and Wire and the more than 40,000 other companies that have successful Payroll Savings Plans.

The United States Government does not pay for this advertising. The Treasury Department thanks, for their patriotic donation, the Advertising Council and

AMERICAN BUILDER



Because of their beauty, durability and versatility, red cedar shingles rank high as a quality roofing and siding material for new home construction. But it is also an excellent medium for exterior remodeling, as these details show.

The choice of open or solid sheathing for roof decking is optional, but in no case should saturated building paper be applied to the roof deck before the shingles are laid.

When applying a new roof over existing wood shingles it is unnecessary to remove the old shingles. To

provide a neat job at the eaves and gable ends, cut the shingles back as indicated in the detail at the bottom of the next page.

Shingles, when laid on a roof, should be spaced at least 1/4 in. apart and only two nails should be used for each shingle. Good practice is to place these nails 3/4 to 1 1/2 in. above the butt line of the next course, and not more than 3/4 in. from the side edges of the shingle.

In applying successive courses of shingles care should be taken to insure proper side lap, so that joints

will be at least 1 1/2 in. apart in adjacent courses, and that joints in alternate courses do not "line up."

The details on page 234 show three different methods of sidewall application. While these details are for new construction, the same practice can be followed for over-walling of existing siding.

On old wood walls, regardless of the type of siding, the shingles can be applied directly as on new sheathing. For application over stucco or brick walls, use furring strips spaced to correspond with the exposure.

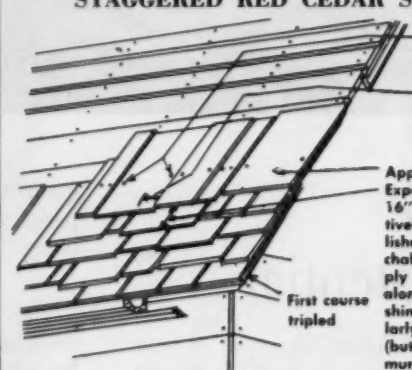
Covering Capacities per Bundle in Square Feet of Various Sized Shingles				Recommended Exposure of Roof Shingles					
Exposure Inches	16" Shingles	18" Shingles	24" Shingles	Pitch of Roof			Exposure of Shingles in Inches		
				Pitch	Rise	Run	16	18	24
3 1/2	17 1/2	15 1/2		1/6	3"	12"	3 3/4	4 1/4	5 1/4
4	20	18			4"	12"			
4 1/2	22 1/2	20		1/3	6"	12"			
5	25	22 1/2			8"	12"	5	5 1/2	7 1/2
5 1/2	27 1/2	25		1/2	12"	12"			
6	30	27	20	3/4	15"	12"			
6 1/2	32 1/2	29 1/2	21 1/2	1	18"	12"			
7	35	31 1/2	23	STAGGERED RED CEDAR SHINGLE ROOF 					
7 1/2	37 1/2	34	25						
8	40	36	26 1/2						
8 1/2	42 1/2	38 1/2	28						
9	45	40 1/2	30						
9 1/2	47 1/2	43	31 1/2						
10	50	45	33						
10 1/2	52 1/2	47 1/2	35						
11	55	50	36 1/2						
11 1/2	57 1/2	52	38						
12	60	54 1/2	40						
12 1/2		56 1/2	41 1/2						
13		59	43						
13 1/2		61	45						
14		63 1/2	46 1/2						
14 1/2			48						
15			50						

FOUR-PLY RED CEDAR SHINGLE ROOF

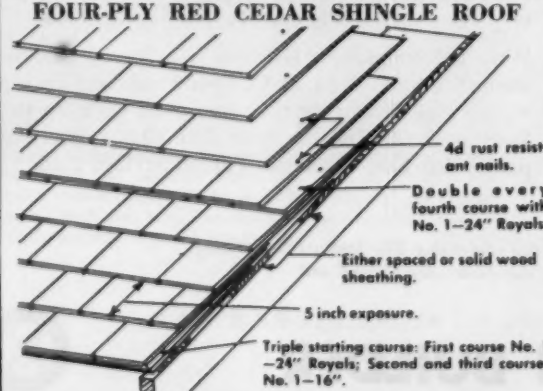

DOUBLE-COURSED RED CEDAR SHINGLE ROOF



red cedar shingles ...

STANDARD RED CEDAR SHINGLE ROOF

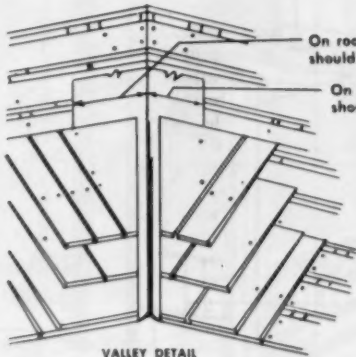

On roofs flatter than half pitch, valley sheets should extend at least 10" from valley center.
On half pitch and steeper roofs valley sheets should extend at least 7" from valley center.

VALLEY DETAIL

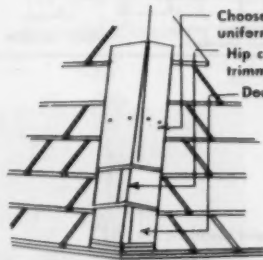

Choose shingles of 3" to 5" uniform width
Hip courses alternately trimmed and beveled
Double starter course

APPROVED HIP

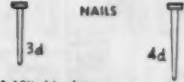
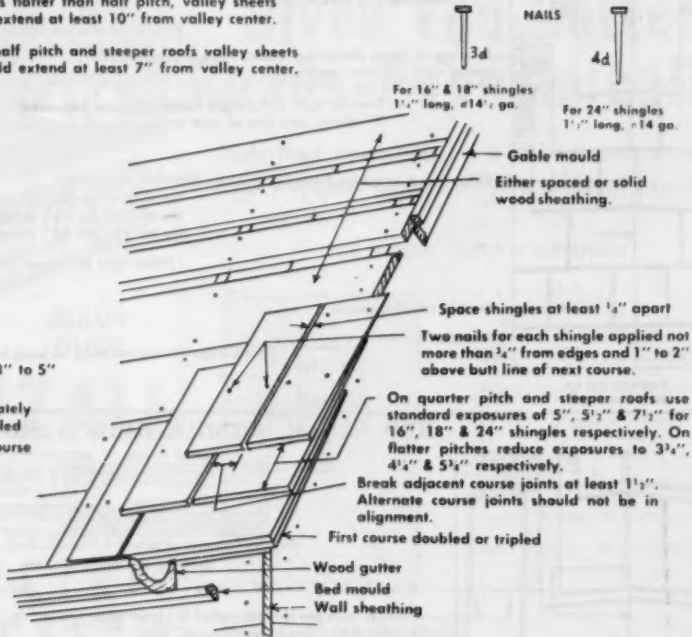

For 16" & 18" shingles 1 1/2" long, #14 ga.
For 24" shingles 1 1/2" long, #14 ga.

Gable mould
Either spaced or solid wood sheathing.

Space shingles at least 1/4" apart

Two nails for each shingle applied not more than 1/4" from edges and 1" to 2" above butt line of next course.

On quarter pitch and steeper roofs use standard exposures of 5", 5 1/2" & 7 1/2" for 16", 18" & 24" shingles respectively. On flatter pitches reduce exposures to 3 1/2", 4 1/4" & 5 1/4" respectively.

Break adjacent course joints at least 1 1/2". Alternate course joints should not be in alignment.

First course doubled or tripled

Wood gutter
Bed mould
Wall sheathing

CORNICE & GABLE DETAIL

RED CEDAR SHINGLE OVER-ROOFING

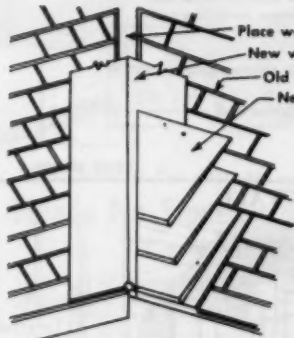

Place wood strip in old valley
New valley flashing
Old shingles
New shingles

VALLEY DETAIL

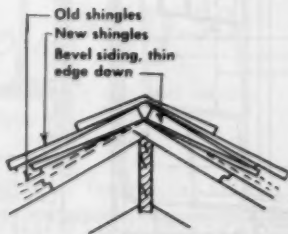

RIDGE CROSS SECTION DETAIL

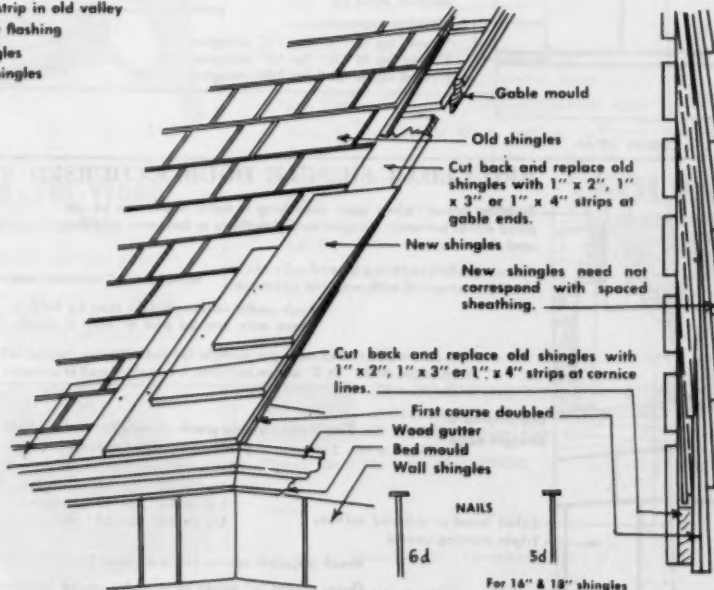

Gable mould

Old shingles

Cut back and replace old shingles with 1" x 2", 1" x 3" or 1" x 4" strips at gable ends.

New shingles

New shingles need not correspond with spaced sheathing.

Cut back and replace old shingles with 1" x 2", 1" x 3" or 1" x 4" strips at cornice lines.

First course doubled

Wood gutter
Bed mould
Wall shingles



For 24" shingles 2" long, #13 ga.

For 16" & 18" shingles 1 1/2" long, #14 ga.

CORNICE & GABLE DETAIL

CROSS SECTION

Courtesy Red Cedar Shingle Bureau

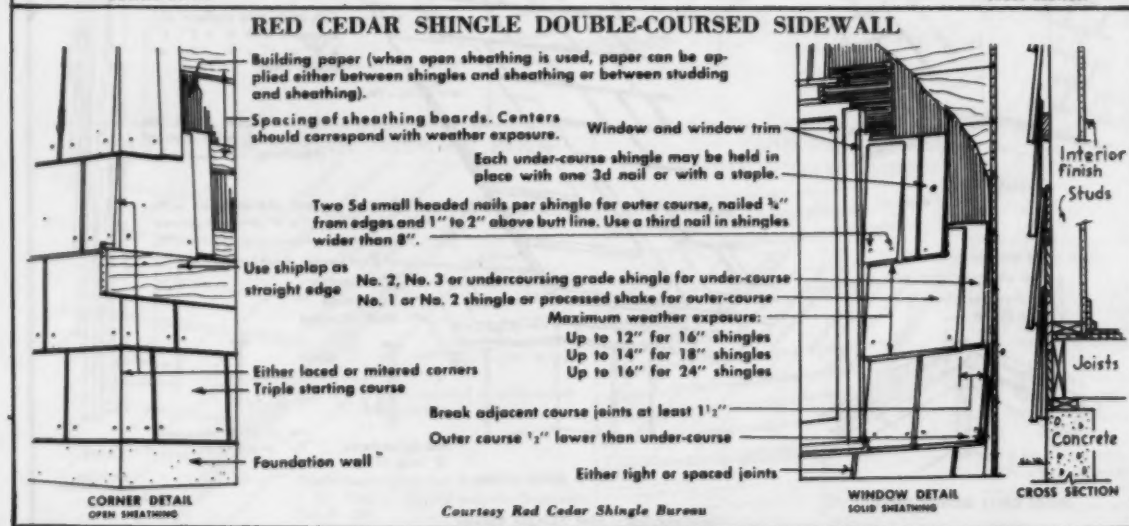
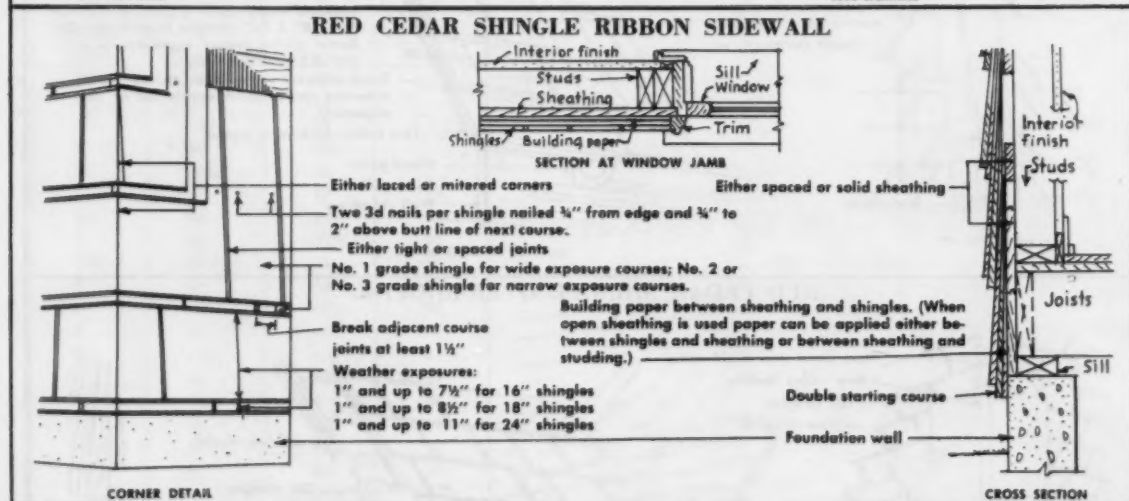
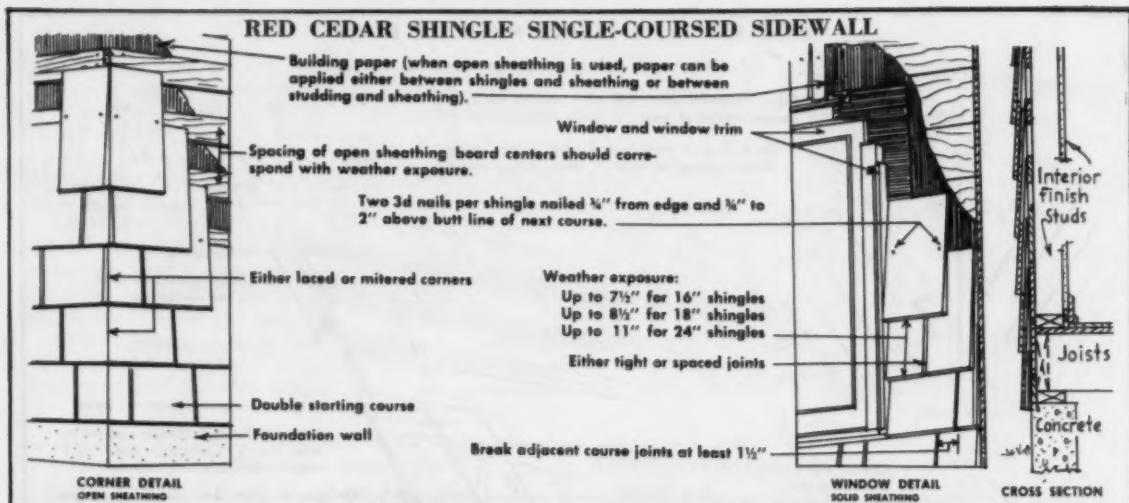

Courtesy Red Cedar Shingle Bureau

REMODEL *Faster*

more JOBS...more PROFIT



with the
New
MODEL
414



Saves Dollars Fast
ON EVERY
Remodeling
Job

**HEAVY
DUTY**

SAWZALL



**NOT AN ATTACHMENT
... but a complete
Self-Contained
ELECTRIC
HACKSAW**

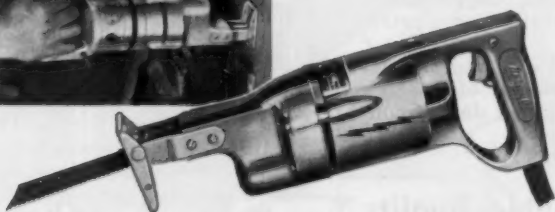

2250 Strokes Per Minute

**Needs No Starting Hole.. In Wood
... or comparable materials**

Compact, lightweight, only 6¾ pounds, the Sawzall answers perfectly the special sawing needs of contractors, home builders, remodelers, plumbers, maintenance men, etc. It breezes through any sawable material including nails, wire, etc. Full ½ h.p. motor, ball and roller bearing equipped, self-lubricating. . . . Available with blades in types and lengths for every sawing need.

Only **\$89.50**

... Complete with steel carrying case and assorted set of Sawzall blades.



Write for free folder SW-6

MILWAUKEE ELECTRIC TOOL CORP.

5356 W. STATE STREET • MILWAUKEE 8, WISCONSIN

SOLVAY CALCIUM CHLORIDE

Gives You Better Roads-Economically!

**Ends Dust Complaints • Reduces Maintenance
Cuts Replacement Costs and Blading Expense**

THIS BOOK TELLS YOU HOW

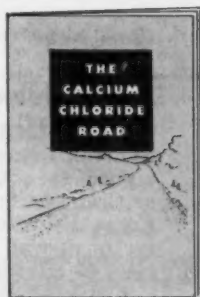

This 24-page, illustrated book, "The Calcium Chloride Road" tells you how you can convert unpaved roads into smooth and dustless consolidated surfaces without a major initial investment and with savings on maintenance!

Now Get All The Facts

Fill in the coupon now and get your copy of "The Calcium Chloride Road." Without cost or obligation, get valuable information on:

1. What is the Calcium Chloride Road?
2. Why the Calcium Chloride Road has a Low Maintenance Cost
3. Why a Calcium Chloride Road has a High Salvage Value
4. How to Plan a Calcium Chloride Road
5. The Composition of a Calcium Chloride Road
6. How to Convert a Road Lacking Sufficient Aggregate or Binder Soil
7. Proper Drainage, Shaping and Blading
8. Application of Calcium Chloride
9. Summer and Fall Maintenance of Calcium Chloride Roads, etc.



SOLVAY PROCESS DIVISION
ALLIED CHEMICAL & DYE CORPORATION
61 Broadway, New York 6, N. Y.

Please send me your FREE BOOK, "The Calcium Chloride Road"

Name

County or Township (or Company)

Address

City Zone State 34-7



SYNTRON CONCRETE VIBRATORS



for uniform compacting and settling of concrete . . .

Syntron Concrete Vibrators are designed to save time and labor in settling and finishing concrete.

Form Vibrator Models—clamp directly to wall forms—Quick acting vise clamp make these Vibrators easily adaptable to many applications.

Flexible Shaft Mass Vibrators are for larger concrete mass settling such as dams, bridges, and piers, etc. Available with gasoline or electric motors.

Electromagnetic Vibrating Floats take the hard work out of floating concrete, make stronger denser concrete.

Other SYNTRON Equipment of proven dependable Quality



ELECTRIC SAWS

Belt driven to insure fast, easy cutting of wood, plaster board, plastic or concrete, no bucking or jerking just smooth high speed power cutting.

ELECTRIC HAMMERS

Fast, easy cutting, chipping or drilling in concrete. Electromagnetic design 3600 powerful blows per minute. Automatic rotation of bit for drilling.



GASOLINE HAMMERS

100% Self-Contained. Drill, dig, cut, tamp. No need for compressor or accessories. Automatic rotation of drill bits.



SYNTRON COMPANY

618 Lexington Avenue

Homer City,

Penna.

BRI ANNUAL MEETING

(Continued from page 26)

vice president of the Timber Engineering Co., who said he considered the boards a competitor for solid lumber in many fields. Rishell noted that last year's production in the United States was 86 million board feet. This year, he said, the total should be much higher. Much of his report was based on a study of uses of particle boards in Europe where lumber shortages make them extremely valuable.

A six-man panel, moderated by Professor Albert G. H. Dietz of M.I.T., discussed the uses of adhesives in building. Consensus of the panel was that plastic adhesives can do many fine jobs, but they must be carefully applied; and, the factory, rather than the field is the best place for this application.

Other sessions on the program included a report on tests in progress for the acceptance of new materials by Neil H. Connor, director of FHA's architectural standards division. FHA must go slowly on this, he said, because every decision has far reaching effects.

Also featured was a technical session on building a large scale community, moderated by Leonard G. Haeger, technical director for Bill Levitt.

Chairmen of various sessions were: M. H. Baker, National Gypsum Co.; F. P. Reynolds, Bird & Son Inc.; Dean Crandell, National Gypsum Co.; and H. F. Robertson, Union Carbide & Carbon Corp.

TEXAS LAND CRISIS

(Continued from p. 116)

2. Hire a manager to boss the operation—a man who knows real estate, development and sales.
3. Delegate responsibility clearly to each participant, and stick to it.
4. Hire the best possible land consultant or subdivision planner, backed by a top engineering staff.
5. Hire an expert C.P.A. and tax consultant to guide the finances.
6. Maintain friendly relations with other builders. In Barton Hills the same price is paid for a lot by any builder, whether a member of the organizing group or not. All reputable local builders are invited to buy on equal terms.

The Barton Hills group hired Shirley White, a builder and past president of the Austin Builders Association as manager. In addition to President Sheppard, other builder members of the group are Berkley N. Holman, Frank Barron, Wayne Burns, Walter Carrington, R. I. Struhall, Jr., Bob Connelly and Jack Andrewartha.

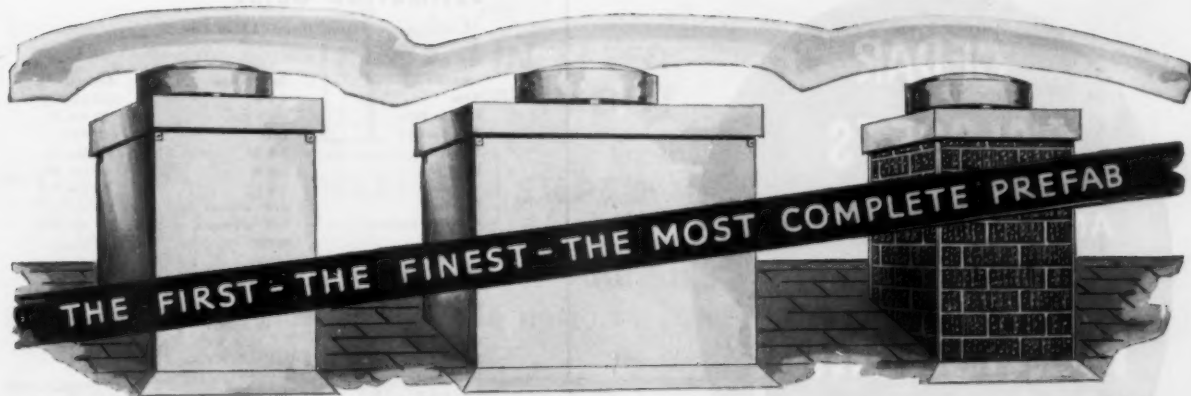

VITROLINER CHIMNEYS—The Logical Choice!

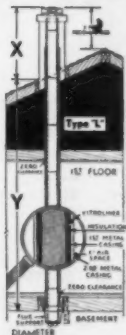

Vitroliner is not only the first and Pioneer Chimney but still the finest quality-built class "A" Chimney on the market for one and two story homes and buildings using all fuels.

The Architect has flexibility and choice. He can specify 2 types "E" and "L" for ceiling or basement installations—3 Designs, as illustrated above—5 Diameters (6", 7", 8", 10", and 12") for correct size—UL listed for 4 Fuels—oil, gas, coal and wood. The Builder prefers lightweight Vitroliner (10 to 15 lbs. per ft.) which is easy to handle and quick to assemble.

The Home Owner enjoys a neat modern design. His Vitroliner adds distinction to the appearance of his home. He also enjoys the safety and long life VITROLINER provides.

Of course, Vitroliner provides complete chimney functions, venting combustion gases from Heating Plant, Water Heater and Incinerator.



For fast quotation, send us "X", "Y" dimensions and flue diameter.

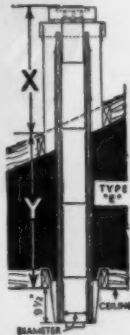

Investigate this nationally accepted quality chimney—write for literature today

CONDENSATION ENGINEERING CORPORATION
3511 W. POTOMAC AVE., CHICAGO 51, ILL.

THERE'S NO GAMBLE...

with
GRAHAM GARAGE DOORS

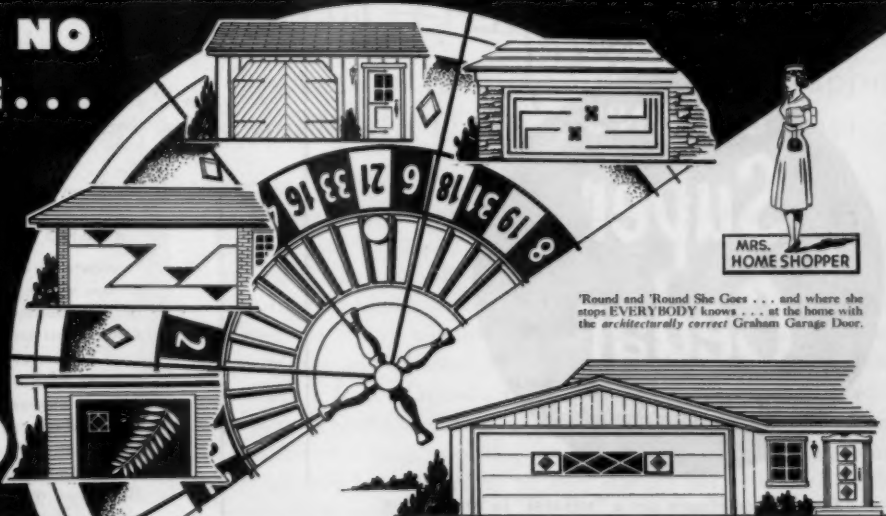

"Round and 'Round She Goes... and where she stops EVERYBODY knows... at the home with the architecturally correct Graham Garage Door."

The spectacular beauty of Graham Doors provide that "custom-design" look to your front elevations at no extra cost. Their unique styling adds real "buy-appeal" to your homes. Be sure to investigate the new "Decorator" economy model... America's lowest price flush sectional garage door. All models are equipped with the perpetually trouble-free Graham mechanism.

Graham Garage Doors

6901 Carnegie Avenue
Cleveland 3, Ohio

Division of
GRAHAM INDUSTRIES, INC.

263 N. Washington Dr.
St. Armonds Key, Sarasota, Fla.

Qualified distributors
being selected in
certain areas.

*ASK ABOUT GRAHAM "INSUL-CORE" COMMERCIAL AND INDUSTRIAL DOORS... BUILT TO LAST.

NO 12.	3 RD 12.	
LACK	19 TO 36	
18 17	20 21	25 27
18 17	22 23	26 28
19 20	24 25	29 30
21 22	26 27	31 32
23 24	28 29	33 34
25 26	30 31	35 36
RED	EVEN	
NO 12.	3 RD 12.	

**CEDAR
CLOSETS**
AN EASY-TO-INSTALL
Remodeling
"natural"



BROWN'S
Super Cedar
CEDAR CLOSET LINING

Cedar-lined closets are a "natural" in remodeling —if You suggest them to your customers!
SUPERCEDAR enables you to do the job fast and profitable. Installs over open studding or over old wood and plaster. Comes in 4 and 8 ft. sealed bundles, tongue-grooved and end-matched. See your nearest building supply dealer.
FREE closet planning booklet and builders' brochure. Write us today!

GEORGE C. BROWN & COMPANY INC.
Largest Mfr. of Aromatic Red Cedar in the World
GREENSBORO, NORTH CAROLINA *Established 1886*

ESTIMATING GUIDE
(Continued from page 115)

Int. Trim Location	Description	Amount
Base	1 x 4	250 Lin. ft.
Clothes Pole	1 1/2" dia.	28 Lin. ft.
Pole Sockets	Pair	7 Pair
Cloats	1 x 3	56 Lin. ft.
Hook Strip	1 x 4	60 Lin. ft.
Shelving	1 x 12	60 Lin. ft.
Paneling	1/4" walnut	288 sq. ft.
Paneling Kitchen	1/4" plywood	192 sq. ft.
Panelite	1/10"	

DOOR SCHEDULE

Ext. Doors Size	Description	Amount
3'0" x 7'6 1/4" x 1 3/4"	Flush S.C.	1
2'8" x 7'6 1/4" x 1 3/4"	Flush S.C.	1
Int. Doors		
2'6" x 6'8" x 1 3/8"	Flush H.C.	3
2'0" x 6'8" x 1 3/8"	" "	2
1'6" x 6'8" x 1 3/8"	" "	2
Sliding Doors		
4'0" x 6'6 1/2"	Batten Doors	6
2'0" x 6'8"		16
2'6" x 6'8"		2
Folding Doors		
2' 9 3/4" x 6'8"		1
2'11 1/4" x 6'8"		1
		—
Total		35

Note: All doors frames, saddles, casings, trim, etc. are to be ordered from the door schedule.

WINDOW SCHEDULE

Size	Description	Amount
4' 0 1/4" x 3'4 1/4"	Sliding Window	4
3'10 1/4" x 2'2 1/4"	" "	15
3'10 1/4" x 5'1 1/4"	Fix Glass	12
3'10 1/4" x 2'2 1/4"	Fix Glass	2
		—
Total		33

Note: All windows are to be ordered from the window schedule to include sash, frame, stops, trim, casings, etc.

Aprons	1 x 6	170 Lin. ft.
Stools	1 x 8	170 Lin. ft.

Material breakdown by Joseph Steinberg, head, and Martin Stempel, senior instructor, Construction Technology Dept., New York City Community College.

BRAND NAME PRODUCTS

- Youngstown kitchen cabinets
- Rheem water heater
- Luxaire counter-flow furnace
- Sonoairduct furnace ducts
- Lima perimeter diffusers
- Federal Pacific circuit breakers
- Mervair air-cooler
- Briggs plumbing fixtures
- Nutone ventilating fan
- Pella folding doors
- Blackstone washer and dryer
- Bruce prefinished flooring
- Alwintite aluminum windows
- Philip Carey insulation
- Thulman chimney
- VisQueen vapor barrier
- Fiberglas perimeter insulation
- Mullins dishwasher, sink
- RCA kitchen range
- General Chrome bath accessories
- International Harvester freezer
- Ruberoid asphalt shingles

1st IN SPEED
IN PROFIT

AMERICAN SUPER 8 SANDER

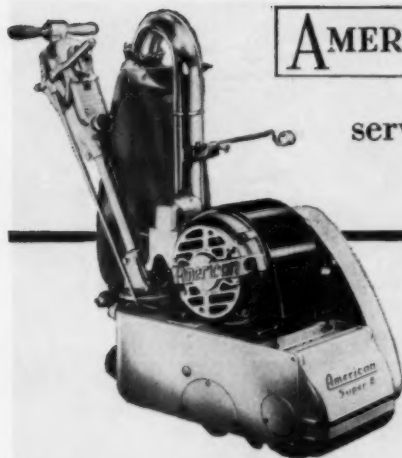

serves the leading floormen
of the nation . . .

The American Super 8 leads in performance with twice the speed of Standard machines. The variable speed drum transmission and drum speed dial selector are typical ahead-of-the-times features by American engineers so you can sand any floor quickly and at a profit.



Get Ahead—
Write us today for
Machine Demonstration
. . . no obligation.

THE AMERICAN
FLOOR SURFACING MACHINE CO.
ESTABLISHED 1903

511 So. St. Clair St.,

Toledo 3, Ohio

NEW!

AMERICAN SUPER SPEED ABRASIVE PAPER

One test will show you beyond all doubt the amazing superiority of the all-new American Super Speed . . . a paper produced on the newest and most modern making machinery in the industry. Try some Super Speed today . . . made for floor sanding by floor sanding experts. It costs no more. Send for price list and free sample sheet . . . no charge, no obligation.



PERFORMANCE PROVED PROFESSIONAL MACHINES FOR CONTRACTOR USE • WORLD-WIDE SALES AND SERVICE

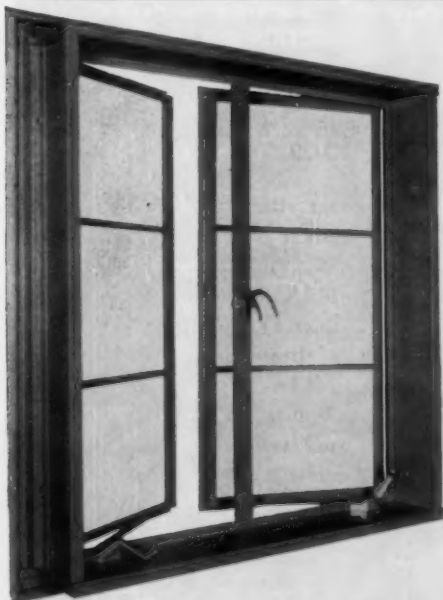

MADE TO ORDER FOR "OHI"
(Operation Home Improvement, sponsored by the U. S. Chamber of Commerce)

You can really save money on modernization and remodeling projects, and at the same time provide steel windows of the very highest quality...When replacing old windows or adding new ones, use HOPE'S RESIDENCE CASEMENTS in Hope's Combination Inside-Outside Steel Trim. Our Inside-Outside Trim entirely eliminates costly window stools, aprons, corner beads, outside mouldings, and the labor costs of fitting and installing these items.

Hope's Inside-Outside Trim is easily assembled and attached to Hope's Steel Casements. The entire assembly can be completely installed in a rough opening in less than 15 minutes. Customers tell us they have saved up to four dollars per window opening using these products.

See our Catalog Inserts in Sweet's Files for additional information,
or write for our folder No. 132-AB

HOPE'S
JAMESTOWN, N. Y.

Since
1818

**INSIDE-OUTSIDE
METAL TRIM**

STEEL WINDOWS HAVE THE STRENGTH AND RIGIDITY THAT NO OTHER WINDOW CAN MATCH

What you can do with a corrugated

AMERICAN BUILDER'S BETTER DETAIL PLATE . . . NO. D-140: CORRUGATED CEILING

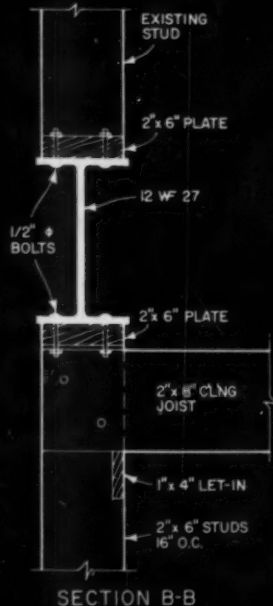
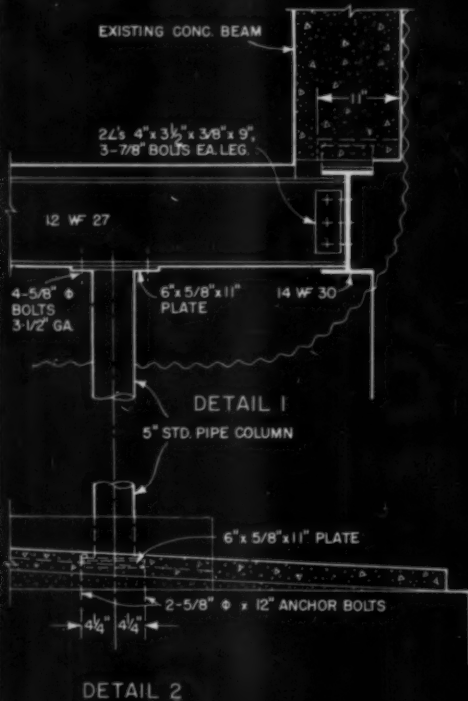
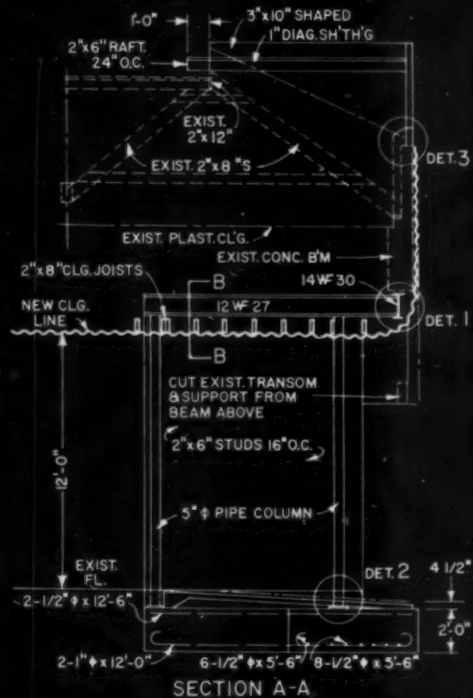
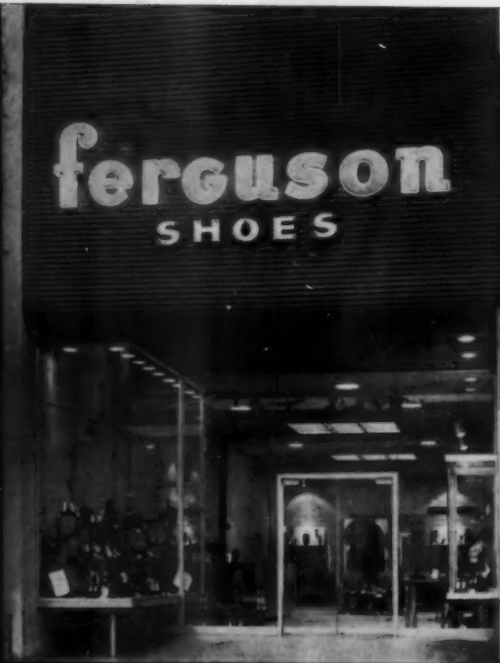

ceiling ...



OLD GIFT SHOP before Pasadena, Calif., architect, builder and decorator made it into a sparkling new shop. Store has 20-foot frontage.

Typical of many small shops and stores badly in need of remodeling, the one shown here got a real face-lifting. The aim was to open up the front with glass and a continuous corrugated ceiling. Existing Spanish ornamentation was thereby concealed, and in its place went a textured surface extending half the length of the store. Painted a blue-grey, the ceiling harmonizes nicely with the tan floor and walls. Color consultant for this part of the operation was Guy Brink.

To make use of the existing skylight, the architect used a wood eggcrate with floods above it. He supplemented these with rows of built-in spotlights.

Where the corrugated sheets of aluminum overlap, they are painted with mastic for a waterproof joint.

Show window and display case are framed with standard Kawneer aluminum extrusions. Both are lit from above with General Lighting Co. Rotobeam lights. These create splashes of light in the vestibule area.

Contractor: Evald C. Moller
Architect: Harold B. Zook
2736 East Walnut St.
Pasadena, Calif.

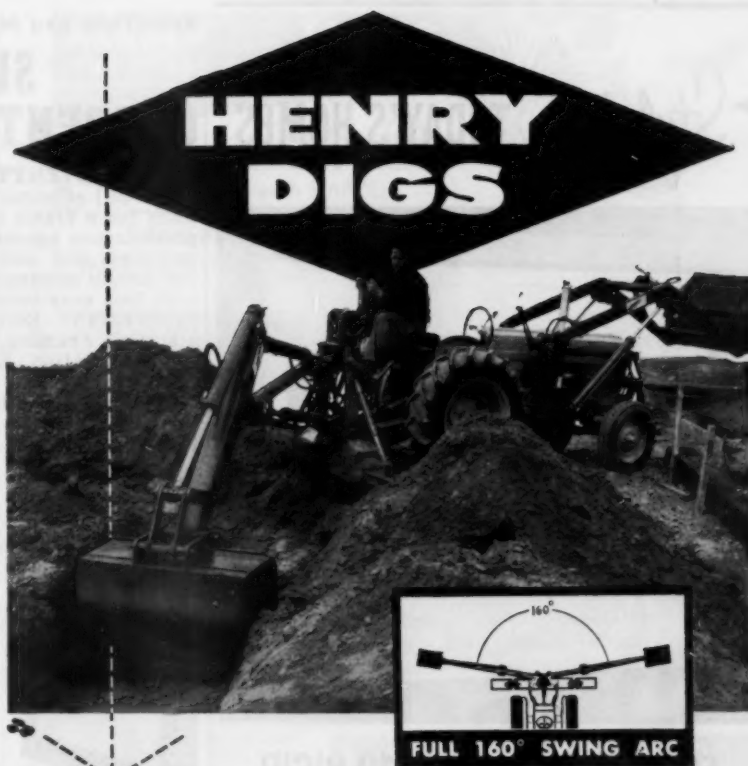

from any **ANGLE** ...

Sharp angles, close quarters—it's all the same with a Henry C-10H Hydraulic Backhoe.

The Henry will dig straight-sided ditches, bell holes, culverts from any angle within its 160 degree swing arc. Even on rough, sloping terrain, the backhoe and tractor level up in seconds for sure-footed digging.

Henry's many exclusive advantages—automatic telescopic boom, regulated down pressure, multi-cylinder operation—save time and labor costs on any digging job.

Team this backhoe with the Henry Industrial Tractor Shovel and you have a one-manufacturer combination that is unmatched in the earthmoving field.

Get the facts on Henry—see your nearest Henry dealer, or write to us today.



"You can do it BETTER with a HENRY"



HYDRAULIC all-purpose EARTH MOVERS

MANUFACTURING COMPANY, INC.

1700 N. Clay Street • Topeka, Kansas

BACKHOES • BACKFILL BLADES • TRACTOR SHOVELS

Styled for TODAY'S HOMES

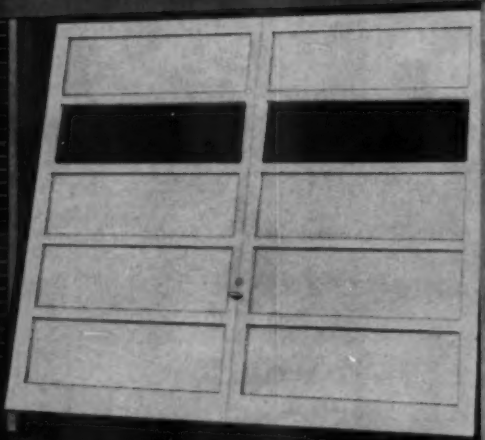

FRANTZ famous No. 10 RIGID OVERHEAD has "New Look" FOR ADDED PRESTIGE APPEAL



with FRANTZ Exclusive SELF-OPENING "POWERMATIC" OPERATION—just turn the handle. Door glides up to full open position!

The Frantz No. 10 size 8' x 7', with its automatic opening feature, has long been the outstanding rigid, or one piece, door in its field. Now it has been given a NEW design to provide the distinguished appearance found in high priced sectionals, but at the low cost of a rigid! Those sleek horizontal lines are also available in No. 7, size 8' x 6'6", No. 19, size 9' x 7' and No. 21, size 16' x 7'. Cash in now on these smartest buys of the year!

Look behind the No. 10, too! You'll find a host of features, like exclusive "Powermatic" self-opening, full length angle braces, heat-treated, oil-tempered power springs, pre-fitted parts for speedy installation, and the low 2" headroom. These and other features—real features—account for the remarkable popularity of the No. 10.

Write today for Catalog No. 302



FRANTZ MANUFACTURING CO., STERLING, ILLINOIS

Save Time and Money . . . Avoid Mistakes . . . Use

SIMPLIFIED CARPENTRY ESTIMATING

HERE IS EVERYTHING YOU NEED to know to "take off" a bill of materials from set of plans and specifications for a frame house. Saves you time figuring jobs, protects you against oversights or mistakes that waste materials and cost money. Nothing complicated—just use simple arithmetic to do house carpentry estimating with this easy-to-use ready reference handbook.

CONTENTS: Estimating Fundamentals. Foundation Material. Framing. Exterior Finish. Hardware. Building Information. Estimating Short Cuts. Labor Hours per Unit of Work. Carpentry Mensuration. Mathematical Reference Tables. Stair Estimating. How to Plan a House.

1950. 5th Ed. 304 p. 123 illus. 60 tables. 5x8. \$3.75

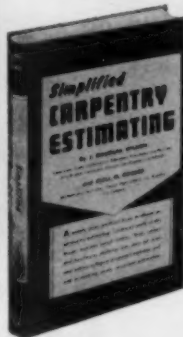

FREE EXAMINATION COUPON

Simmons-Boardman Books, Dept. AB-756
30 Church St., New York 7, N. Y.

Please send me a copy of *Simplified Carpentry Estimating*. If after 5 days trial I am not fully satisfied, I'll return it and owe nothing. Otherwise I'll keep the book and send \$3.75 plus a few cents for postage and handling in full payment.

Name

Street

City State

SAVE. Send \$3.75 with your order. We pay postage, handling. Same trial terms.

STEEL LAUNDRY CHUTE DOOR

(PUSH-IN TYPE)

**Ideal for Bathroom or Kitchen Remodeling
Easy Installation Reduces Labor Costs**

- Fits Flush with Wall and is Less Conspicuous as NOTHING Protrudes into Room.
- Leaves BOTH Hands Free to place Cumbersome Laundry into Chute.
- Has TWO Springs that Close Door Firmly and with More FIRE SAFETY than Other Doors.



Write for Catalogue No. 756 showing our complete line of registers for perimeter, gravity and air conditioning installations.

Please send copy of Catalog 756 and details on the Steel PUSH-IN TYPE LAUNDRY CHUTE DOOR

NAME

ADDRESS

CITY STATE

THE A & A REGISTER COMPANY

8327 CLINTON ROAD • CLEVELAND 9, OHIO

WANTED!

Just one shred of evidence to prove AMERICAN BUILDER'S '56 Technical and Marketing Guide isn't the most comprehensive and usable sourcebook of building and buying data in the field.

Whatever your job . . . builder, contractor, sub or special-trade contractor, architect or consulting engineer . . . you'll find it a valuable time-saver every working day of the year. Whatever your need . . . in design, structural materials, hardware, equipment, tools . . . this book is brimming with information to short-cut your problems.

This April reference issue has the answers that help you get ahead faster. Use it profitably . . . and often!

AMERICAN
BUILDER

CLASSIFIED ADVERTISING

The Market Place for buying and selling used merchandise, help wanted, positions wanted, and other classified listings.

Rates—\$7.50 minimum for 40 words or less. 15c for each additional word.

Display Classified—\$35.00 per inch. Reverse plates not accepted. No illustrations. No agency commission or cash discount. One column only—2¼ inches wide. 2 inches maximum. Signature cuts and trade names allowed.

NOW AVAILABLE FOR NATIONAL DISTRIBUTION

Heretofore only available in the Great Lakes area, franchised dealers and distributors can now obtain the famous Metlach Ceramic Clay Tile—imported from France—which was selected and featured in many of the national Home Shows. Produced according to a 200 year old formula by one of the world's largest clay tile manufacturers, employing over 10,000 craftsmen, this mirror-like wall tile gives the effect of carrara glass without increasing the cost of the individual installation.

Metlach Tiles are larger than most domestic tiles and are fabricated in brilliant decorator colors or marbleized panel shades, at a cost comparable to domestic tile. They are tested and fully guaranteed against cracking, peeling or crazing.

For free literature and samples write to the Factory Warehouse of The Durable Floor and Tile Company, 2012 Euclid Avenue, Cleveland 15, Ohio.

HELP WANTED

Buyer Wanted: Large retail yard in Northern Indiana needs a man experienced in buying large volume lumber and building materials. Good salary plus participation in profits with opportunity to buy an interest. Our key employees know about this ad. Write Box #258, American Builder, 30 Church St., New York 7, N. Y.

BUILT-IN REFRIGERATOR AND FREEZER TERRITORIES AVAILABLE

Manufacturer of built-in freezers and refrigerators has open territories for commission salesmen in the New England, Eastern Seaboard, Southern, Southwestern and Montana areas. State experience in the appliance industry and indicate other lines you are carrying now. Write Box #259, American Builder, 30 Church St., New York 7, N. Y.

HANSEN ONE-HAND TACKER CUT COSTS ON THIS JOB

You, too!

Can Cut Your Costs—Do A Faster, Better Job—with HANSEN

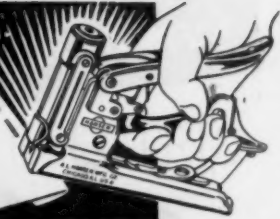

... TACKING INSULATION



Hansen Tacker tacking insulation—one of many uses in doing a faster, better job, and cutting costs.

ZIP! ZIP! FAST AS YOU GRIP—HANSEN drives Tackpoints for installing insulation, hydron, metal lath, cornerite, building paper—and does many other tacking and fastening jobs.

CUTS COSTS! Light weight, readily portable, one-hand operation; rapid, positive driving action; balanced design; steady, on-the-job performance are features that insure economical operation and low-cost installation.

A BETTER JOB—FASTER! Accurate driving, with precision-made Hansen Staples, insures faster work without waste of time, steps or materials. Hansen holds 84 to 140 Tackpoints per strip. Staple sizes up to ½" length. Tackers in 36 models. Specify —buy—use HANSEN!

REQUEST
FOLDER

A. L. HANSEN MFG. CO.

5029 RAVENSWOOD AVE., CHICAGO 40, ILL.

YOU CAN BUILD YOUR OWN

TECO ROOF TRUSSES



by using Teco data and Wedge-Fit timber connectors

HOME BUILDERS save time, material, and labor with TECO Trussed Rafters that are simple to fabricate, easily assembled, and quickly erected with minimum labor.



Send for FREE Teco Trussed Rafter data for your specific jobs.

Timber Engineering Company

1319 18th Street, N. W., Washington 6, D. C.

AB-565

I am planning to build . . . houses. Please send FREE data on . . . foot span trussed rafters, with a slope of . . . in 12, also booklet on "How to Build Wood Frame TECO Trussed Rafters."

Name.....

Firm.....

Street.....

City..... Zone..... State.....

MODERN BUSINESS



AND MODERN SCHOOLS



NEED EACH OTHER MORE THAN EVER!

This has been a great year! America is building and replacing and thus moving faster than ever before.

Only one thing. Will the labor market keep pace?

That's where schools are important. If your company isn't helping community groups to get modern schools, it's not apt to get the skilled people it needs. Self interest, civic spirit, or both, you should make schools your business, too.



Want to find out how to help in *your* community?
Get specific information by writing:
Better Schools, 9 East 40th Street, New York, N. Y.

take a good look at WESTERN RED CEDAR



one of 10 woods from the

WESTERN PINE region

Great resistance to decay, dimensional stability, high insulating qualities, workability, nailability, light weight make Western Red Cedar an excellent and economical wood for all residential construction—and preferred for weather-exposed usage such as poles, greenhouses, boats and floats.

Western Red Cedar comes in 3 select and 5 common grades. You can order it in mixed cars—together with other woods from the Western Pine region—from most Western Pine Association member mills!

the Western Pines

IDAHO WHITE PINE
PONDEROSA PINE
SUGAR PINE

the Associated Woods

RED CEDAR
LARCH
DOUGLAS FIR
WHITE FIR
ENGELMANN SPRUCE
INCENSE CEDAR
LODGEPOLE PINE



get the facts to help you sell WESTERN RED CEDAR
write for the FREE illustrated booklet to
WESTERN PINE ASSOCIATION
Yeon Bldg., Portland 4, Oregon

Today's Way of Living
Calls For Electric Heat . .

ELECTROMODE

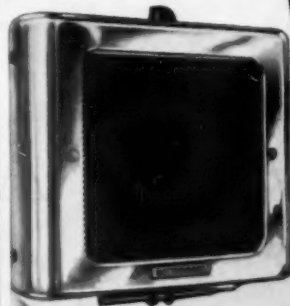

**ELECTRIC
HEAT
FITS THIS
PICTURE**



ELECTROMODE offers you a complete line of all-electric heaters designed for comfort in any room or every room throughout the house.

Take the bathroom, for example. Many times it's the deciding factor. Electromode heaters add eye-catching beauty and a promise of comfort and convenience that prospective home buyers can't resist. These heaters are available in a choice of gleaming chrome or white enamel finish.



EASY-TO-INSTALL COMPLETE SAFETY

ONLY Electromode heaters are equipped with a sealed-in, **CAST-ALUMINUM HEATING ELEMENT**. Absolutely no glowing elements or exposed open coils. Tops in safety, efficiency and economy.

Included in Electromode Line Are:

- Wall and Portable Heaters • Panel Heaters
- Baseboard Heaters • Radiant Cable Heat
- All With Automatic Room Temperature Control

ELECTROMODE

Division Of
COMMERCIAL CONTROLS CORPORATION

"Leaders in Electric
Heating Since 1929"

**Mail The Coupon TODAY
Get All The Facts**

Electromode Division, Commercial Controls Corporation
Dept. AB-76, 45 Crouch St., Rochester 3, N. Y.

Please send me your FREE brochure on the complete Electromode line of electric heaters for homes.

Name.....
Address.....
City..... State.....

The Month Ahead

PLUMBING MONTH

August is national plumbing, heating and cooling month. Some 65,000 plumbing and heating contractors will be urged to dress up their shops, make free estimates, give local bargain rates and advertise on a stepped-up scale.

YOUR TIE-IN

Here's how you can get in on this promotion. Make a special point of featuring bathrooms, powder rooms, kitchens, etc. A number of manufacturers, in case you weren't aware of it, are going in for built-ins in a big way—lavatory-vanities, with sliding medicine chests, cosmetic drawers, and other extras. They're designed for either bedroom or bath use and come in a variety of decorative colors. Get the facts from your dealer. And don't overlook new comers like this: baths with integral seats.

AUSTIN EXPERIMENT

Keep an eye peeled for more data to come from Ned Cole's air-conditioned village in Austin, Tex. Per diem costs, Cole says, average seventy cents for cooling alone, or about \$90 a year. Builders need more figures like these in order to sell the public on air-conditioning.

FALL IS OHI TIME . . .

Since housing generally slackens in the fall, use this as an opportunity to step up your modernizing program. For leads, your plumbing contractor is again your best bet . . .

The hotter the better

July and August can be your best salesmen if you'll give them half a chance. Pull a half-convinced prospect off the hot street and into an air conditioned model house, wait for him to cool off a little, then give him your sales pitch. Chances are he won't run away, because he knows it's hot outside; and all of a sudden this cooling business—which he has always thought of as a luxury—can be the trigger that switches him from a prospect into a buyer. This is definitely not an overdone sales angle, by the way; according to the Air Conditioning and Refrigeration Institute, only about 150,000 central systems will be installed this year—about half of them in new houses—and this is only a small part of the potential market.

August is the air conditioning issue

If we've whetted your appetite for more air conditioning dope, then the August issue of American Builder is a must for you. Here's what you'll find: a Builder's Buying Guide that will show the latest trends in air conditioning equipment; a "grass roots" field report on where and why builders across the country are turning to air conditioning today; and finally, a special article on how and why Levittown, Pa., the biggest development in the USA, is including central air conditioning as standard equipment in its latest bigger model homes.

Here come the parades

The weeks between now and September are the time during which you should be getting ready for the housing industry's biggest promotion, National Home Week. Whether you're participating in a parade of homes or planning a merchandising program of your own, now is the time to get busy on it. And while you're at it, remember American Builder's Best Model Home contest goes hand in hand with National Home Week. This would be a good time to start lining up a photographer, and to start getting together your blueprints. The complete rules of the contest will be in the August issue—don't miss them.

New "Color Blended" Formica Patterns *Sell for you!*



LINEN
Petal Pink
Lipstick
French Blue

PEARL
Cardinal
Primrose
Gulfstream

SKYLARK
Primrose
Pink
Aqua

MILANO
Pink
Gray
Antique

more than 70 colors to choose from

FREE!

Samples of New Formica Colors—also information on Formica's Model Home Merchandising. Fill in coupon now.

DEMAND THIS CERTIFICATION

This mark certifies genuine
RUB OFF WITH LOTS OF BAR SOAP ON A DAMP CLOTH

Subsidiary of

CYANAMID

Guaranteed by
Good Housekeeping

FORMICA

Laminated Plastic

Pays in Performance

FORMICA CORPORATION

4514 Spring Grove Avenue, Cincinnati 32, Ohio

In Canada: Arnold Banfield & Co., Ltd., Oakville, Ontario

Please send me free samples of the new Formica Sunrise Colors.

Model Home Merchandising Information

NAME _____

ADDRESS _____

CITY _____ STATE _____

Seeing is believing. If this wash-off identification is not on the surface, it's not FORMICA.

National still a favorite among builders

— because of its modern-
 ess in style and design
 — as well as "built-in"
 strength and stamina

Actual service records attest to these claims for the wearing qualities of National Builders' Hardware.

FIRST the basic materials are chosen for their known strength and adaptability to the service the hardware is to perform.

SECOND the style and design must be mechanically correct to minimize friction and resultant wear.

THIRD the importance of simplifying installation is an important factor as a means of curtailing excessive labor costs.

FOURTH the general attractiveness of the hardware is essential for eye appeal and the protective finishes to guard against rust and deterioration—all these features help make National Builders' Hardware today's best buy!



National MANUFACTURING CO ★ STERLING ILLINOIS