

# Use the best—

Elastica is *lighter, bulkier*  
= covers more square yards  
to the ton



Manufactured by

U. S. MATERIALS CO.	- - - - -	CHICAGO
AMERICAN MATERIALS CO.	- - -	NEW YORK
ART STUCCO MATERIALS CO.	- - -	DETROIT
NORTH WEST MATERIALS CO.	- - -	ST. PAUL

# Use the best—

Elastica is *lighter, bulkier*  
= covers more square yards  
to the ton



Manufactured by

U. S. MATERIALS CO.	- - - - -	CHICAGO
AMERICAN MATERIALS CO.	- - - - -	NEW YORK
ART STUCCO MATERIALS CO.	- - - - -	DETROIT
NORTH WEST MATERIALS CO.	- - - - -	ST. PAUL



# *it costs no more*

**E**LASTICA is the highest quality stucco that it is humanly possible to manufacture. The best ingredients are used; it is permanently waterproofed—it is a carefully and expensively prepared material. Necessarily, it does cost more per ton—*But it does not cost more per yard.*

That means that it doesn't cost *you* any more to use Elastica than it does to use ordinary stucco. And in using it you make greater profits:

First, you can make more money in using Elastica, because the cost of application is not as great; in one working day, one man and a helper can apply 20 to 25 yards more Elastica than ordinary stucco—thus cutting labor costs.

Second, it is easier to sell, and brings better prices, because it is a *well-known* quality material—its reputation helps you sell it.

And finally, the purchaser of an Elastica job becomes a satisfied owner, so that every job will bring you other prospects, and other Elastica jobs.

# ELASTICA

THE WATERPROOFED STUCCO

# ANNOUNCING NEW MODELS -

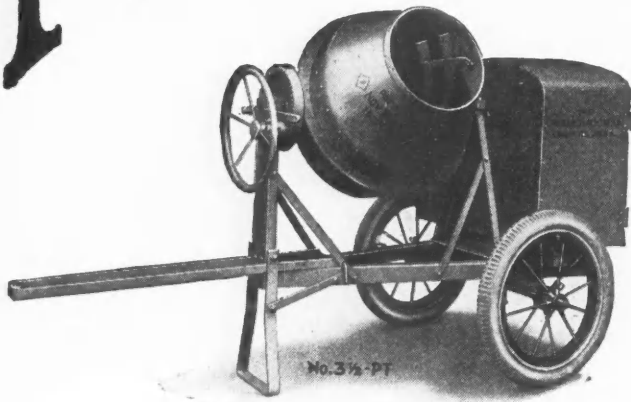

No. 3 ST Jaeger Trailer Mixer on 2-28 inch Steel Wheel

**Price \$166.00**

Net Cash f. o. b. Columbus, Ohio

No. 3½ ST Jaeger Trailer Mixer on 2-28 inch Steel Wheels

**Price \$190.00**

Net Cash f. o. b. Columbus, Ohio

Extra for Pneumatic Tired Wheels . . . \$24.00

Extra for Solid Cushion Tired Wheels - 33.00

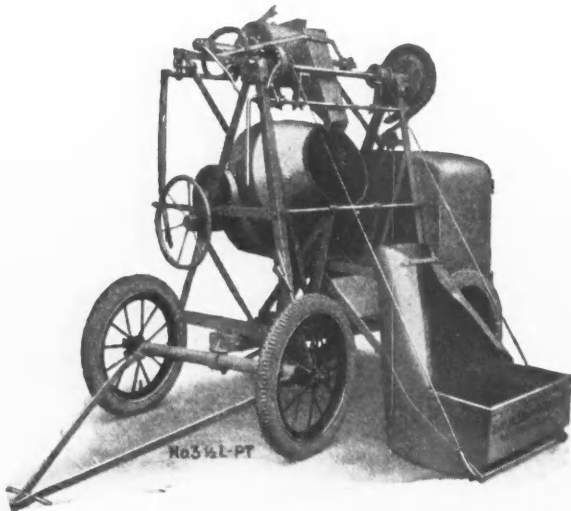

No. 3½ L-ST on 4-28 inch Steel Wheels less Watertank

**Price \$313.00**

Net Cash f. o. b. Columbus, Ohio

No. 3½ L-CT on 4-30x3½ Solid Rubber Cushion Tires with Watertank

**Price \$408.00**

Net Cash f. o. b. Columbus, Ohio

**J**AEGER has scored another big hit with the concrete industry! *Quantity production—greater factory efficiency—simplicity of design—huge purchasing power—and volume sales.* These are the factors that have enabled us to offer contractors the greatest possible values in concrete mixers. Our 1925 models and prices are the successful result of years of concentration in making but one line of machinery—*concrete mixers.*

This singleness of purpose has achieved great savings for every contractor. Our entire organization thinks, plans and works to one end—that Jaeger "Tilting-Drum" Concrete Mixers shall be "the first and last word" in concrete mixing efficiency and economy. How well we have succeeded is evidenced by *the thousands of contractors who now use Jaeger Mixers—on every type of concrete construction!*

Jaeger now manufactures six sizes of concrete mixers—and thirty-six different models. We show on this page the No. 5-L, the one-sack mixer; the 7-L for a sack-and-a-half mix; the 3½-L-PT, the new, ideal half-sack machine; and the 3½-PT for trailer service.

(Over 30,000 Jaeger Mixers have been sold since 1912.)

The Original  
**JAE**  
Tilting -

# JAEGER MIXERS

## AND THEIR PRICES !

The big features of the Model 1925 Jaeger Mixers are:

1. Exclusive, patented Jaeger tilting-drum.
2. Exclusive patented loader.
3. Exclusive patented semi-automatic discharge.
4. Exclusive patented water tank.

Every model has interchangeable wheels and can be equipped with steel, pneumatic or cushion tires. Each of them is backed by the Jaeger Guarantee of complete satisfaction. And when you buy them you buy not only a dependable, efficient machine but the service that this organization renders every purchaser.

Write us today for copy of our new 1925 catalog. With it we will send you the name of our distributor in your town. Have him demonstrate for you the superior advantages Jaeger Concrete Mixers offer you.

*All tilting-drum mixers are not Jaegers. There are many imitations but only one original Jaeger Tilting-Drum Mixer. Why consider imitations when you can buy an original Jaeger Mixer for the same or less money? Look for the name of the drum and the flat spots inside.*

**The Jaeger Machine Co.**  
 318 Dublin Road Columbus, Ohio

# GER

## Drum Mixers

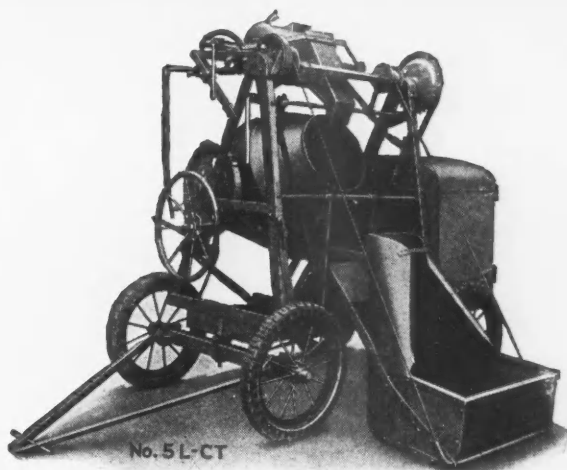

No. 5L-ST on 4-28 inch Steel Wheels less Watertank

**Price \$456.00**

Net Cash f. o. b. Columbus, Ohio

No. 5L-CT as illustrated on 4-solid Rubber Cushion Tired Wheels complete with Watertank

**Price \$560.00**

Net Cash f. o. b. Columbus, Ohio



No. 7L-1 on 4-28 inch Steel Wheels less Watertank

**Price \$645.00**

Net Cash f. o. b. Columbus, Ohio

No. 7L-1 as illustrated on Solid Rubber Wheels with Watertank

**Price \$765.00**

Net Cash f. o. b. Columbus, Ohio

# SARGENT

*Locks & Hardware*

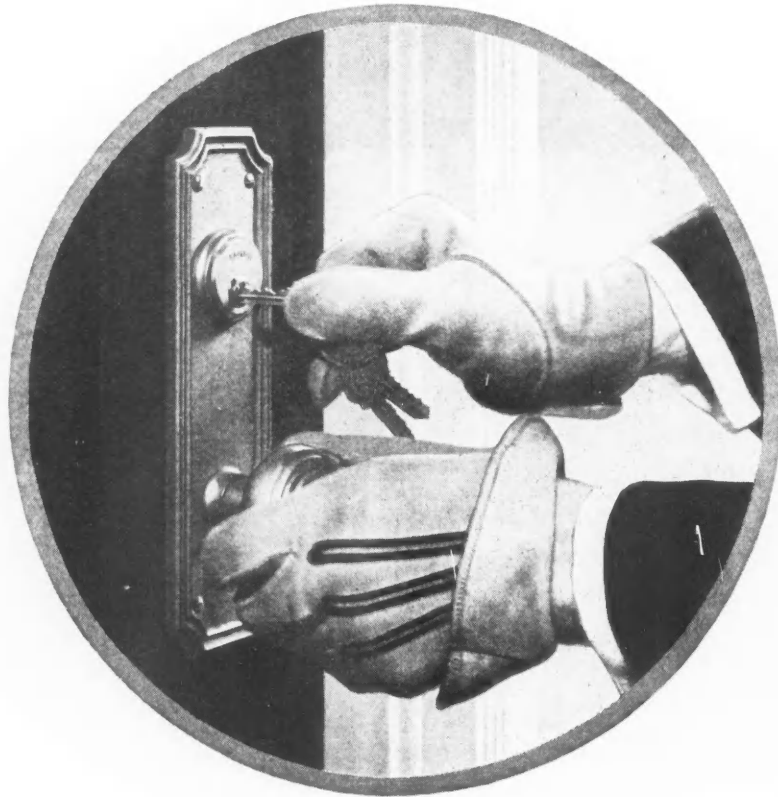

## For mansion or six-room house— *Sargent Builder's Hardware*

MANY builders think that Sargent Locks and Hardware of solid brass or bronze are only for pretentious buildings. It is true that no better hardware is made for the costly structure. But at the same time there is none more practical or more truly economical for the moderately priced dwelling.

Sargent Hardware is an asset of considerable value to the small-home builder. His sales appeal necessarily is based on a few prominent

details. One of these is, or should be, hardware. The better appearance and greater service of Sargent Hardware can conveniently be called to the prospective buyer's attention. He can safely be told that he is paying a slight additional cost to insure hardware convenience and security as lasting as the home itself. He is easily convinced that it's worth the difference.

Styles for every building purpose—homes, apartments, hotels and offices.

**SARGENT & COMPANY, Hardware Manufacturers**  
51 Water Street, New Haven, Conn.



## SARGENT PLANES AND SQUARES

*designed only for professional use!*



WHEN you buy Sargent Planes and Squares, you are investing in two of the finest tools that carpentry and manufacturing skill have developed. Years of use in shops and on building operations have proved the uniform excellence of Sargent designs and the constant quality of Sargent construction. The one high standard never varies. Every Sargent Plane is in the strictest sense—a professional tool.

Many carpenters consider Sargent Framing Squares the most accurately scaled and

completely tabled squares on the market. They really do most of the calculating for the carpenter—giving cuts for common, hip, valley, jack and cripple rafters as well as all top, bottom and side cuts. Each is carefully tested for trueness and accuracy of marking. Made in royal copper, nickel-plated, galvanized and other durable finishes. See Sargent Planes and Squares at your dealer's. Two popular Sargent Planes are shown below. Write us for descriptive booklets.

SARGENT & COMPANY, *Manufacturers* 51 Water Street, New Haven, Conn.

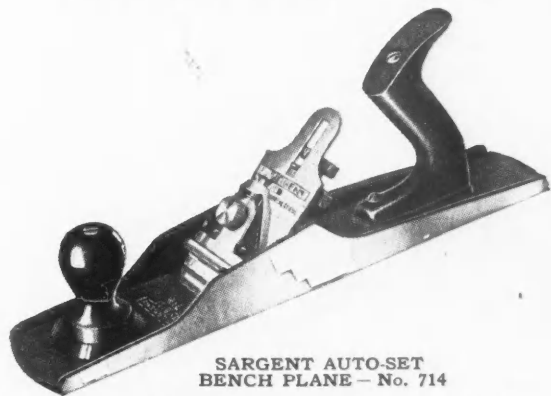

SARGENT AUTO-SET  
BENCH PLANE—No. 714

A time and labor saver. The Auto-Set feature permits chromium steel cutter to be removed, sharpened and replaced without changing original adjustment. Never chatters when in place. Solid, compact, simply constructed. Smooth, jack, fore and jointer—in all sizes.



SARGENT ADJUSTABLE IRON  
BENCH PLANE—No. 414

Heavy chromium steel cutter (No. 12 gauge) offsets usual tendency of spring cap plane to vibrate when used across or against the grain. Cutting edge of cutter held rigidly against frog by foot of clamp. Made in all sizes—smooth, jack, fore and jointer.

# SARGENT

*Tools & Hardware*



# Save

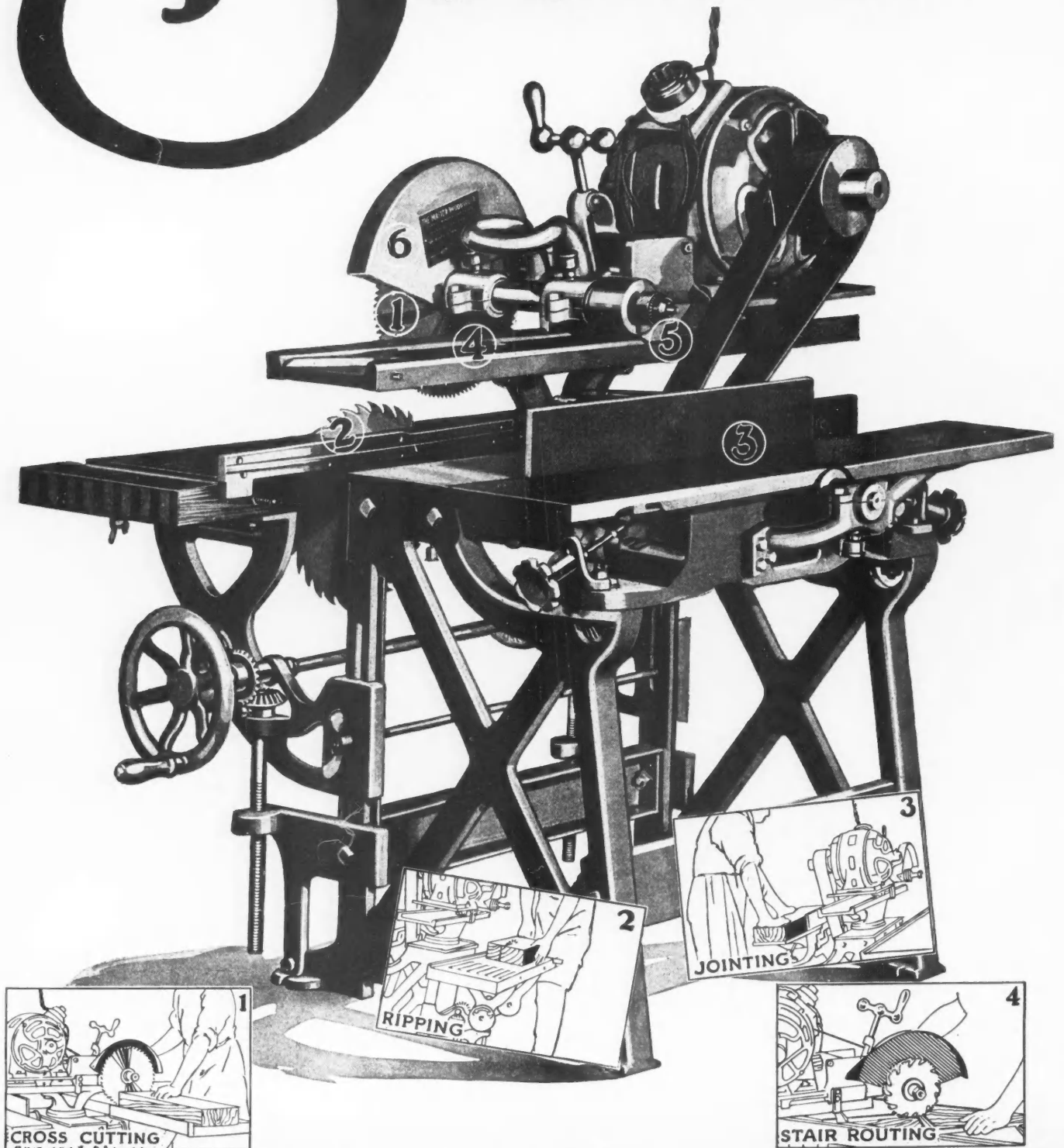

WHEN WRITING ADVERTISERS PLEASE MENTION THE AMERICAN BUILDER

# 4 men's wages

The Master Woodworker will actually save four men's wages, [some contractors even put it as high as six men]. Yet the annual interest on your investment in this wonderful machine will be actually less than you would have to pay one carpenter for six days' work.

The Master Woodworker will last a lifetime, depreciation and upkeep expense being so small that it hardly need be considered.

In other words, a Master Woodworker will give you *each year* for the rest of your life, the equal of approximately 1200 days of expert labor at the price you would pay a man for ten or twelve.

We will be glad to thoroughly prove these claims if you will sign this coupon and give us a chance.

We will prove them by giving you a big book full of blue prints and detailed description so you can see for yourself what the Master Woodworker can do.

We will prove these claims by the signed statements of successful contractors who have used the machine for years.

We will prove them by sending you the machine on an easy payment plan so you can let it pay for itself. And we will give you the privilege of

returning it and getting your money back if you don't find that it does exactly as we claim.

Think of what this saving will mean to you this year in increased profits. Think of the advantages it will give you in estimating and bidding. And all for a small down payment, no more than you would pay a man for a few days' labor.

But you ought to act now so that we can make quick delivery and let it begin to earn money for you all during this big building year.

## What It Will Do

It is twelve machines in one—the fastest and most accurate woodworker on the market. It crosscuts four inches thick, rips four inches thick, dados—does routing, planing, rabbeting, boring, ripping, grinding, stair housing, jointing, moulding, crosscutting, tenoning, mitering, plowing and mortising.

Not a saw rig, but a complete woodworker. The saw travels at any angle and goes through the work the natural way. It can be transported from job to job in a Ford "pickup"

It will handle 80% of all the work in most cabinet, pattern or carpenter shops.

It will make every cut necessary for house building or inside finishing. Connectable to either 110 or 220 volts. Can be easily transported from room to room. Works accurately—no vibration—work at all times visible to the operator. Sturdy and reliable. Will last a lifetime.

*Model illustrated is the No. 9, also made in a larger size for millwork and in two smaller sizes.*

## MASTER WOODWORKER

MANUFACTURING COMPANY

Brush and Congress Streets

Detroit, Michigan

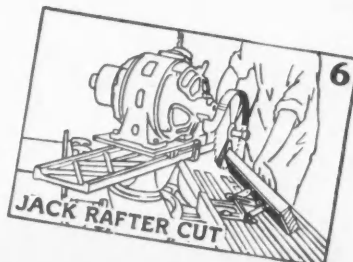
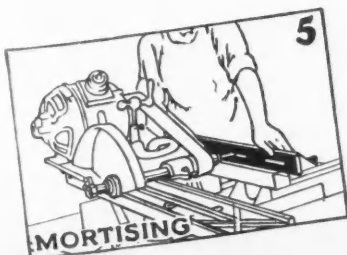

Mail This Coupon  
for Free Big Book

Master  
Wood-  
worker  
Mfg. Co.

Brush and Congress  
Streets  
Detroit, Michigan

Send me your Big Book  
free showing me how to Save  
4 Men's Wages.

Name \_\_\_\_\_

Address \_\_\_\_\_

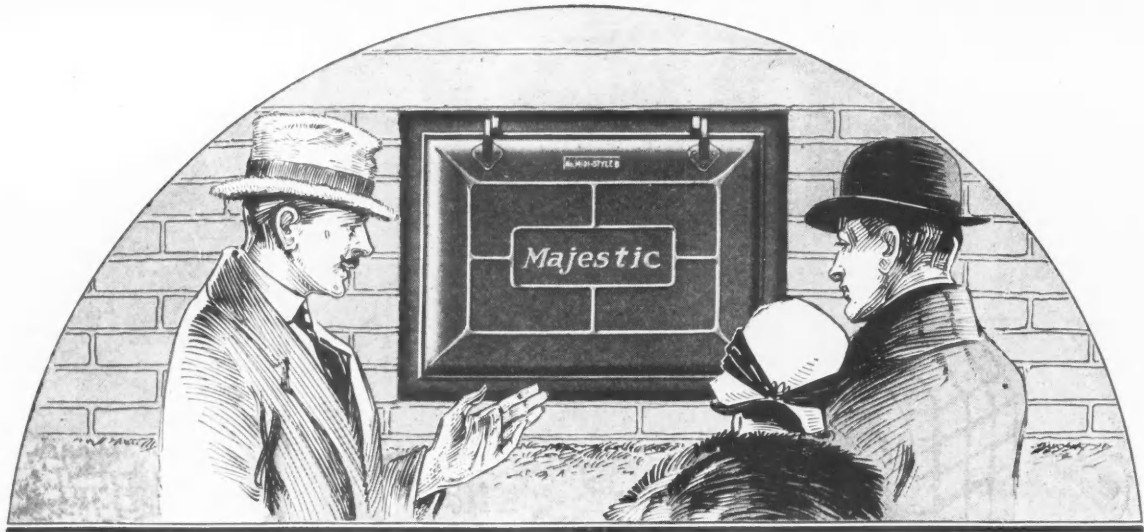

## The Recognized Standard of Quality

WHEN you point out a Majestic Coal Window, folks recognize it instantly as a mark of quality. It says "good value"—and it strengthens all you have said about the hidden features of the home.

The Majestic is the accepted standard of coal window quality and value, because of its break-proof, rust-resisting construction—

made of Certified Malleable Iron and Keystone Copper Steel, with electro-galvanized pressed steel door.

No wonder the Majestic Coal Window is a selling asset in a home. No wonder more and more builders are putting the Majestic in the homes they build to sell, as well as those they build on contract.

STYLES AND SIZES FOR EVERY REQUIREMENT. WRITE FOR CATALOG AND DEALER'S NAME.

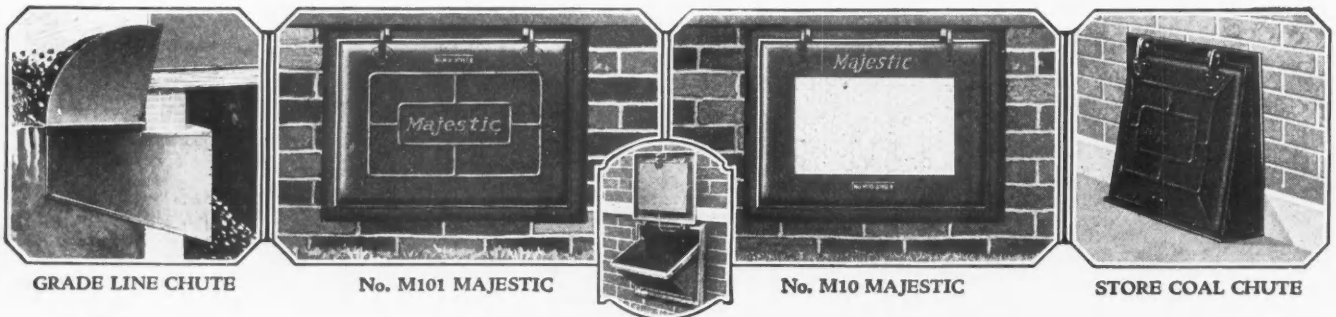

# Majestic Coal Window

BREAK-PROOF ~ RUST-RESISTING

OTHER MAJESTIC QUALITY PRODUCTS  
NEEDED IN EVERY HOME



GARBAGE RECEIVER

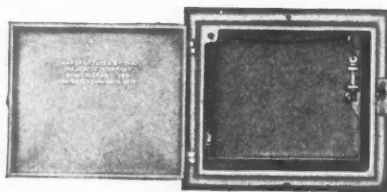

PACKAGE RECEIVER

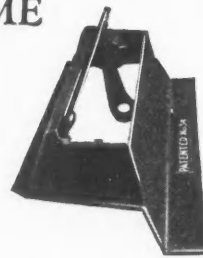

FIREPLACE DAMPER



THE MAJESTIC COMPANY / HUNTINGTON, INDIANA

WHEN WRITING ADVERTISERS PLEASE MENTION THE AMERICAN BUILDER

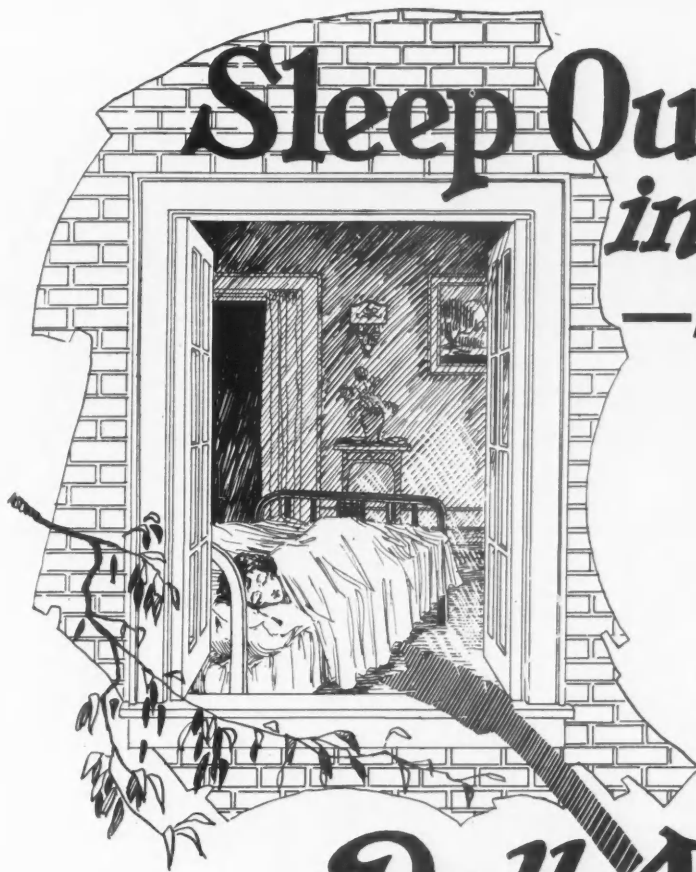

# Sleep Out O' Doors in any room —fresh air is essential

Roll-A-Way Beds roll to any window and through any door.

Absolutely unattached and require no special closets.

The Roll-A-Way Bed provides an additional bedroom in any old or new home.

The Roll-A-Way is real furniture—made in the latest designs and finishes.

## Roll-A-Way

### Unattached—Placed Anywhere

The large ball-bearing, rubber tire rollers make it extremely easy to roll over carpeted floors.

The heavily rubber tire wheels protect the finest rugs and floors.

The thick felt bumper extends beyond the bed in all directions protecting the bed, the trim, and the furniture in room.

**BUILDERS.** Show your client how the installation of Roll-A-Way Beds will actually save them real money.

Write today for complete information. Send your floor plans and receive the money saving suggestions of our technical department and pass them on to your clients.



### Roll-A-Way BED CORPORATION

ROLL-A-WAY SLEEPING SYSTEM

225 WEST OHIO STREET  
(AT GRAND AVE 'L' STATION)

CHICAGO

WHEN WRITING ADVERTISERS PLEASE MENTION THE AMERICAN BUILDER



## The pick o' the pines— *Pondosa*

An inventory of the standing timber of the world reveals but little pine to compare with Pondosa, the wonder-wood from the Inland Empire of the Great Northwest. Builders say it's great wood to work with. They mean its freedom from objectionable features; the way it takes nails in short grain without splitting; the way it dresses up and takes the paint. Every trade-marked stick of this all-purpose lumber is rigidly *graded*, thoroughly *seasoned* and carefully *milled*. For sale by all good lumber dealers. Write for the Pondosa story. Address Dept. 22, Western Pine Manufacturers Association of Portland, Oregon.

## Pondosa Pine

*The Pick o' the Pines*

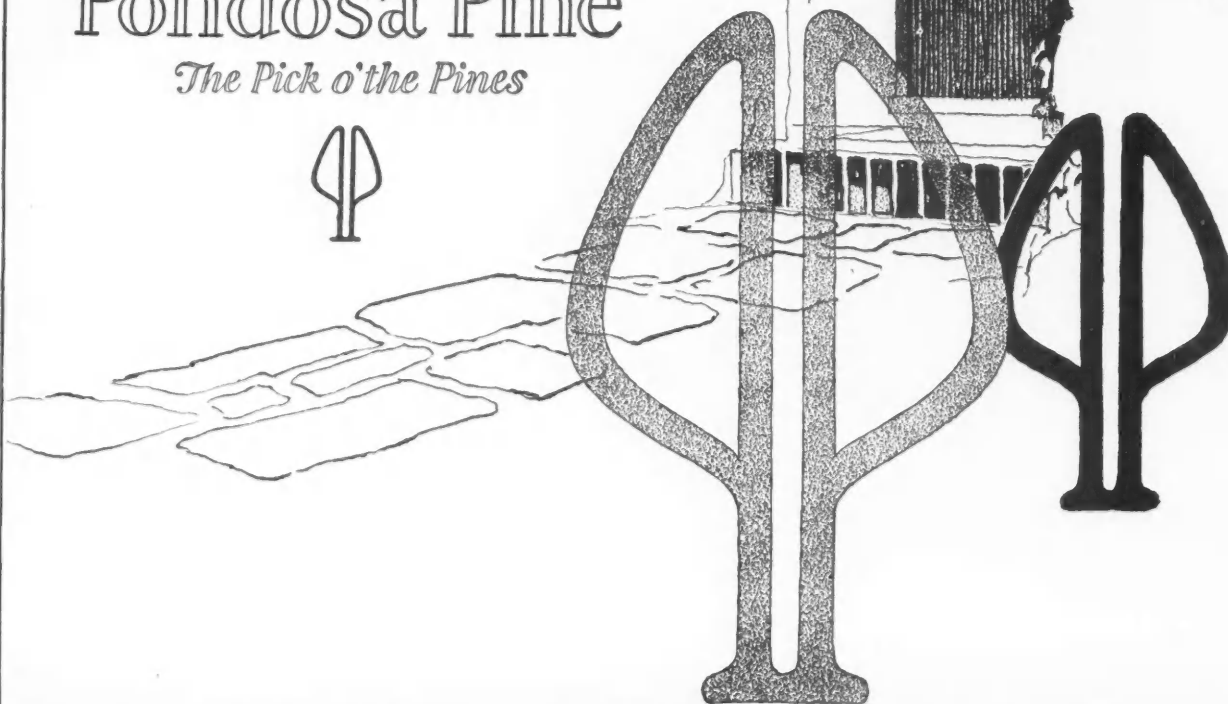



# Nature Contributes Permanency to **Kawneer** SOLID COPPER STORE FRONTS

*With*



## Pure Copper

For Rugged Strength—for Resistance to Weather, for Long Life and Unfailing Service, Kawneer specifications call for *Pure Copper*.

That Kawneer Solid Copper Store Fronts are built to last indefinitely is best established by the fact that the first complete installation, which was put in 20 years ago for the F. Johnson Co., of Holdrege, Nebraska, is still in good condition.

Study the six features of Kawneer Supremacy illustrated in the panel to the left. Then mail the coupon and learn, without cost or obligation, how Kawneer Store Fronts improve the appearance of any store and increase the merchant's sales and profits by making passers-by Stop, Look and Purchase.

The  
Kawneer Company,  
2126 Front St.,  
Niles, Michigan.

Please send me without obligation  
"Design Book" of Kawneer Solid Copper  
Store Fronts.

Name.....

Address.....

City..... State.....

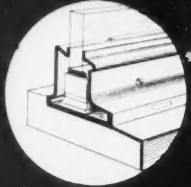

PERMANENCY

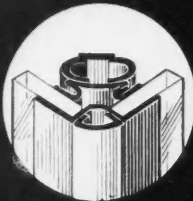

RUGGED STRENGTH

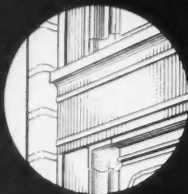

BEAUTY of DESIGN

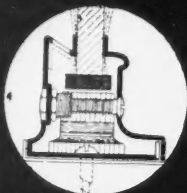

RESILIENCY

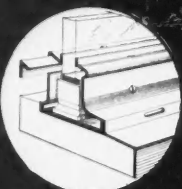

VENTILATION

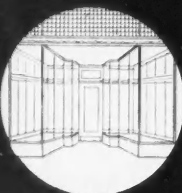

EASE of INSTALLATION

# Control the Trade Traffic with **Kawneer** SOLID COPPER STORE FRONTS

Every town and city has its favored business arteries.

To control trade traffic and divert business from beaten paths has long been one of the major accomplishments of Kawneer Solid Copper Store Fronts.

M. E. Jolley, of Sesser, Illinois, proved this to his satisfaction only recently. "My sales have increased 50%," he writes, "although my present store location is not considered as good as my old one."

Why not get further information concerning Kawneer Solid Copper Fronts for store installations you now have under contract? The coupon on the opposite side of this page is for your convenience—and the information is gladly sent without cost or obligation.

*(See other side for Six Points of Kawneer Superiority.)*

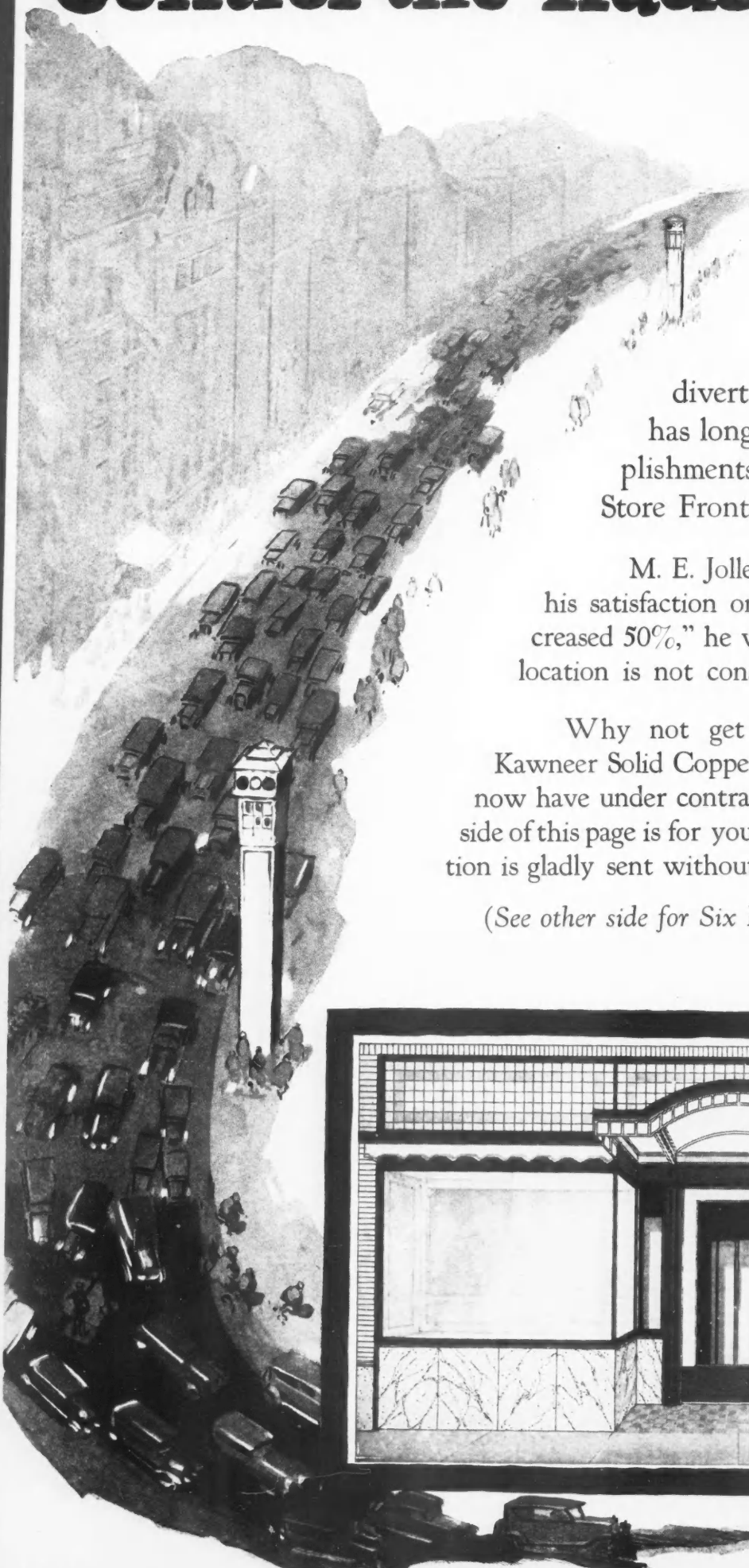
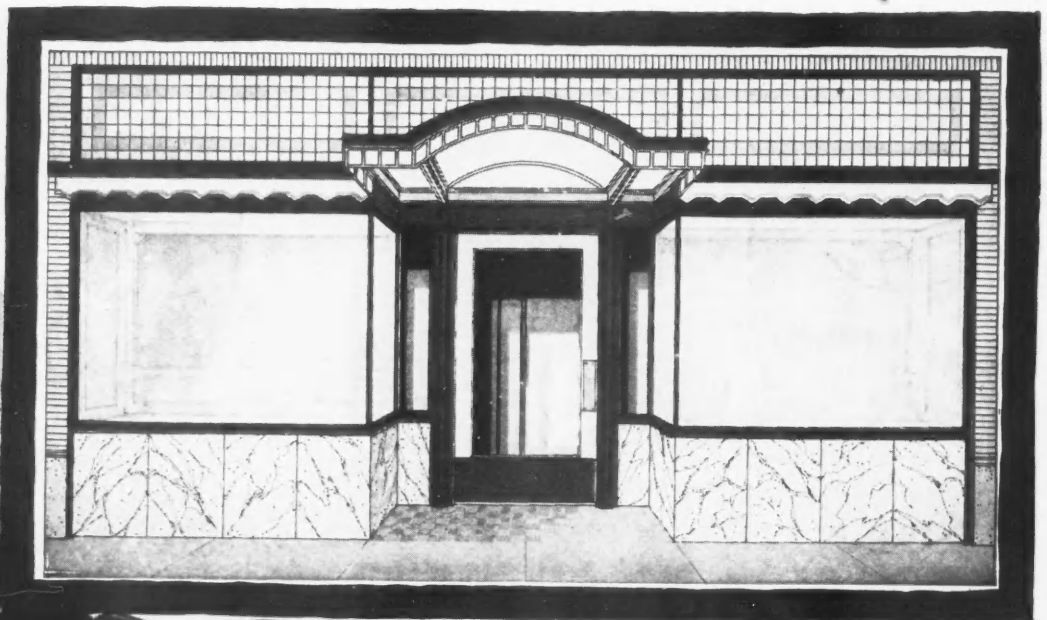

# You!

## Who are you?

You're the fellow who pays and pays for dissatisfaction more times than for satisfaction.

You're the fellow who specifies the hardware on most of the jobs you erect.

You're the fellow who gets the blame if a door doesn't hang correctly even though the fault lies in the hardware.

You're the fellow who is passing up the easiest way in the world to distinguish the kind of hardware that will eliminate 95% of your troubles.

*You can't go wrong when the goods are guaranteed.*

FRANTZ MANUFACTURING CO.  
STERLING, ILL.

*The stack of labels produced in the Frantz factory daily, each backed by an unlimited guarantee.*



*"Distinguish the Hardware by the Label"*

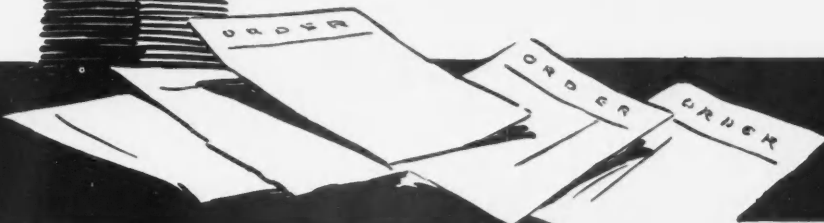



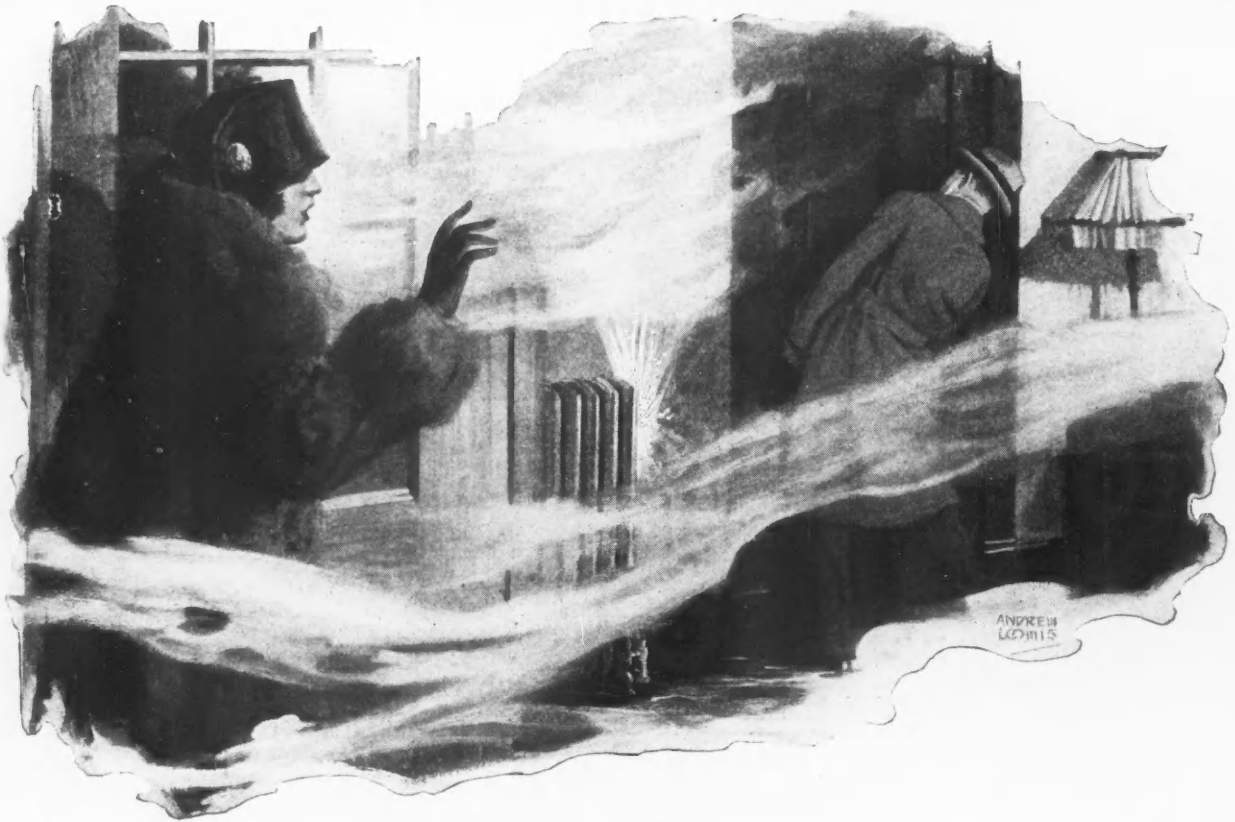

## If a steam pipe burst— what would it do to the door?

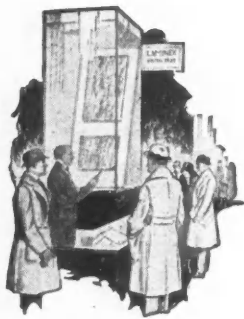

SINCE originated a year ago by the Forest Products Laboratory, University of Washington, this famous Laminex water test has been successfully repeated by Dayton Sash and Door Company, Dayton; McPhee and McGinnity, Denver; Hortman Company, New Orleans; Tacoma "Own Your Home" Exposition, Tacoma; Cole Manufacturing Company, Memphis; McCauley, Brooklyn; California Industrial Exposition, San Francisco; South Texas Fair, Beaumont; and other leading door distributors and building material expositions. Under this rigorous test, no Laminex door has ever warped or come apart!

**E**VEN THE STEAM from a broken radiator *can not* make Laminex doors stick or jam!

Common doors, under such abuse, will warp and twist and swell tight. Steam blisters their surface, leaving an ugly defect. The doors *must be* planed down and rehung!

Laminex, however, has been subjected to heat, water and strength tests at the University of Washington—has survived warehouse fires that twisted common doors out of shape—has gone through floods—and come through without warping or twisting!

Laminex is made of old-growth Douglas fir—built up by a crossing process called "lamination"—much different from doors with solid stiles and rails which have no counter-check against warping. By uniting layers under tremendous pressure with the waterproof cement, we put amazing strength into Laminex.

Progressive dealers everywhere stock Laminex. Send for our free monograph for architects and builders. We will also send actual sample of Laminex wood so you can make the famous Laminex water test for yourself.

**THE WHEELER, OSGOOD COMPANY, Tacoma, Washington**

Sales Offices: New York,  
Memphis, Los Angeles,  
San Francisco, Spokane,  
London, England

Manufacturers of  
Laminex Doors  
Waco Doors and  
Fir Sash

# LAMINEX DOORS

WILL NOT SHRINK, SWELL OR WARP

WHEN WRITING ADVERTISERS PLEASE MENTION THE AMERICAN BUILDER

# Armstrong's Linoleum

for Every Floor in the House



Look for the  
CIRCLE A  
trade-mark on  
the burlap back

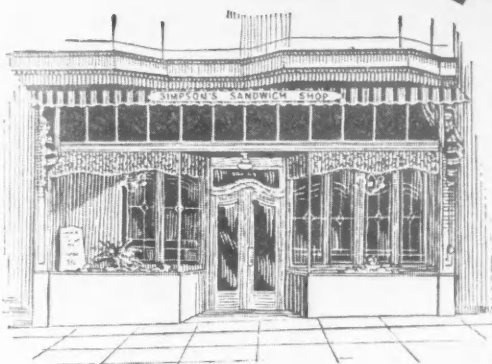

This is the Simpson Sandwich Shop, in San Francisco, Calif. The floor is Armstrong's Marble Inlaid Linoleum, Pattern 71, cemented over a deadening felt lining on a subfloor of concrete. Installation by the Redlick Newman Company.

**Have You the Current Specification Book?**

The fourth completely revised edition of "Armstrong's Linoleum Floors," the architect's and builder's linoleum handbook, contains 36 pages of data, including specifications for laying, tables of gauges and weights, and colorplates. Bound in 8½ x 11-inch manila folder. Free to any contractor upon request.

The Armstrong specifications are also contained in the Nineteenth Edition of Sweet's Architectural Catalog, pages 512-517.

## Floor Beauty in the Smart Shop

HOW quickly an appropriate linoleum floor can make over a simple little refreshment shop! Take away this floor of Armstrong's Marble Inlaid, and half the appeal of this place is gone.

This pattern of red-brown-and-yellow-streaked gray marble, interspersed with six-inch blocks of black, is one of a score and more of fine new designs in Armstrong's Inlaid Linoleum of special interest to the architect. These designs give you color and design in floors at moderate cost. Any linoleum floor can usually be completely and permanently installed for from 25 cents to 50 cents a square foot.

Every shop, store, restaurant, and office can afford to have a beautiful linoleum floor, quiet, comfortable, long wearing, and easily maintained. If you are not familiar with the fine patterns available in Armstrong's Linoleum, ask for the 1925 edition of the Armstrong Pattern Book, which shows colorplates.

Armstrong Cork Company, Linoleum Division, Lancaster, Pa.

B-29





*"Built For the Years" of WESTERN RED CEDAR*

*Lovely home of W. H. Miller, American Lake, Wn. Frederic and Stanley T. Shaw, Architects, Tacoma, Wash.*

## Every Builder Should Know This Wood and How to Use It

Easier sale or rental follows when you build of Western Red Cedar from the Pacific Northwest—"The Wood that Nature Armed Against Decay." Home buyers are learning rapidly about this unusual wood which insures exceptional durability with low upkeep expense.

Western Red Cedar is one of the most durable woods known. It is proof against rot and insect attack of all kinds. It contains no pitch or resin. It works with the greatest ease. It positively does not shrink, warp or buckle. It nails well and it accepts paint beautifully.

For siding, roofs, all exterior trim, one-piece shutters, for all uses involving exposure to weather or contact with soil, and also for some interior uses, Western Red Cedar offers more than any other available wood.

Leading yards stock Western Red Cedar from the Pacific Northwest. Any yard can get it readily. Mail the coupon below today for valuable information on uses for this money-saving wood. No cost; no obligation.

**Red Cedar Lumber Manufacturers' Association**  
4849 Stuart Bldg., Seattle, Wash.

**MAIL THIS NOW!**

Red Cedar Lbr. Manufacturers' Assn.,  
4849 Stuart Bldg., Seattle, Wash.  
Please send me full particulars about Western Red Cedar.  
Name.....  
St. and No.....  
City.....  
State.....

3-25

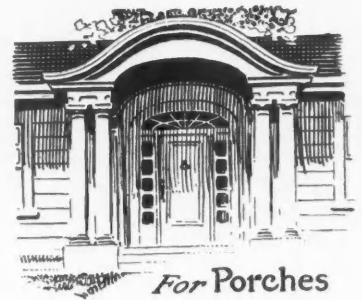

# Western Red Cedar

*"The Wood That Nature Armed Against Decay"*

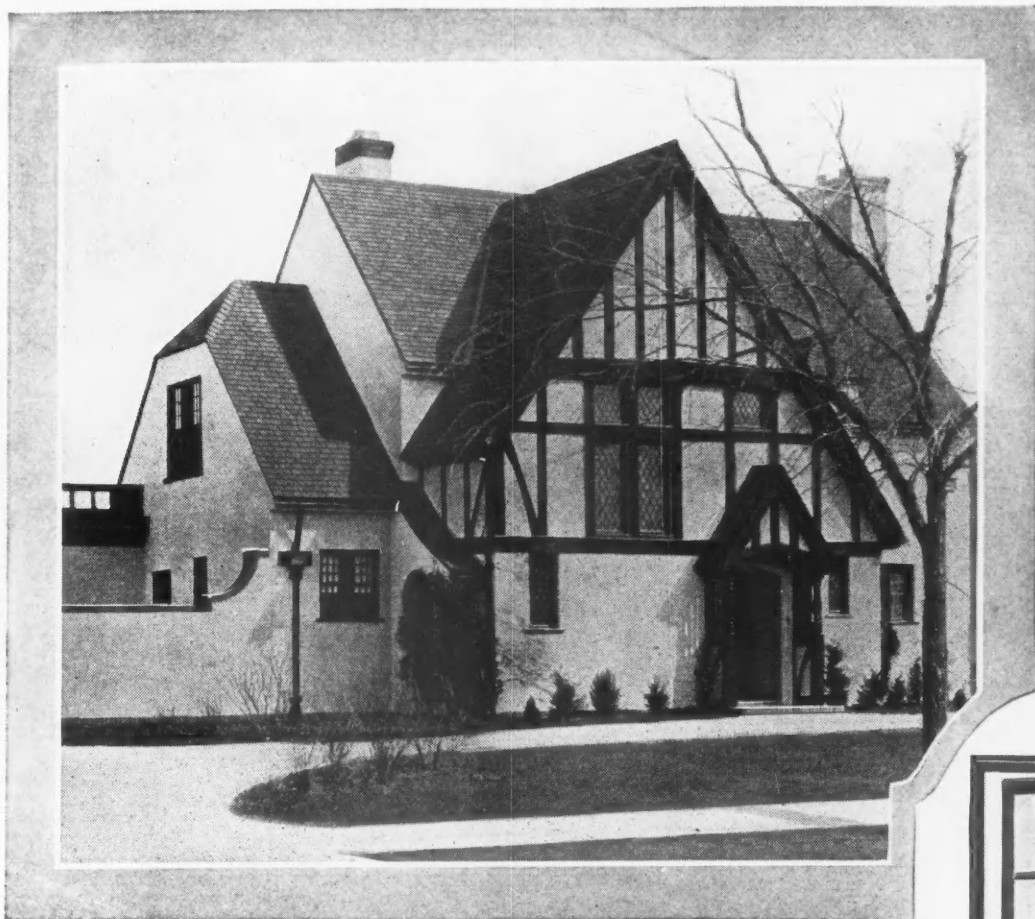

## CRITTALL

### Standard Steel Casements Attract Buyers and Stimulate Sales

The use of Crittall Standard Steel Casements lends a distinctive appearance to a home that immediately lifts it above the average. Prospective buyers are first attracted by their charm, then quickly sold through their practical utility.

Crittall Standard Casements can open either in or out, and when properly installed are guaranteed weather tight. No weatherstripping is required. Hardware is of solid bronze, finished a beautiful dark statuary color. Glazing may be either clear or leaded glass.

Quick sales and complete and lasting owner satisfaction are factors which will readily appeal to every home builder. Insure fast turnover of your completed houses by installing Crittall Standard Steel Casements.

Illustrated Catalogue No. 2-24 giving sizes and types may be had upon request. Screen details are also shown.

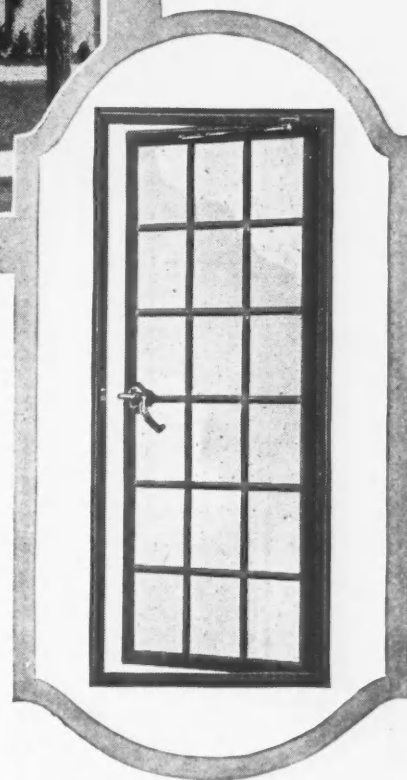

*Crittall Standard Steel Casements are made of Crittallooy—The Copper-bearing Steel.*

#### **Crittall Cottage Casements**

Are standard in size and design and low in cost for use in small residences, apartment houses, etc. They have the usual advantages of steel over wood in that they can be easily operated under varying weather conditions. Made to open out only. Ask for Cottage Casement literature.

CRITTALL CASEMENT WINDOW COMPANY, *Manufacturers*  
10953 HEARN AVENUE, DETROIT, MICHIGAN

WHEN WRITING ADVERTISERS PLEASE MENTION THE AMERICAN BUILDER

# Capitol

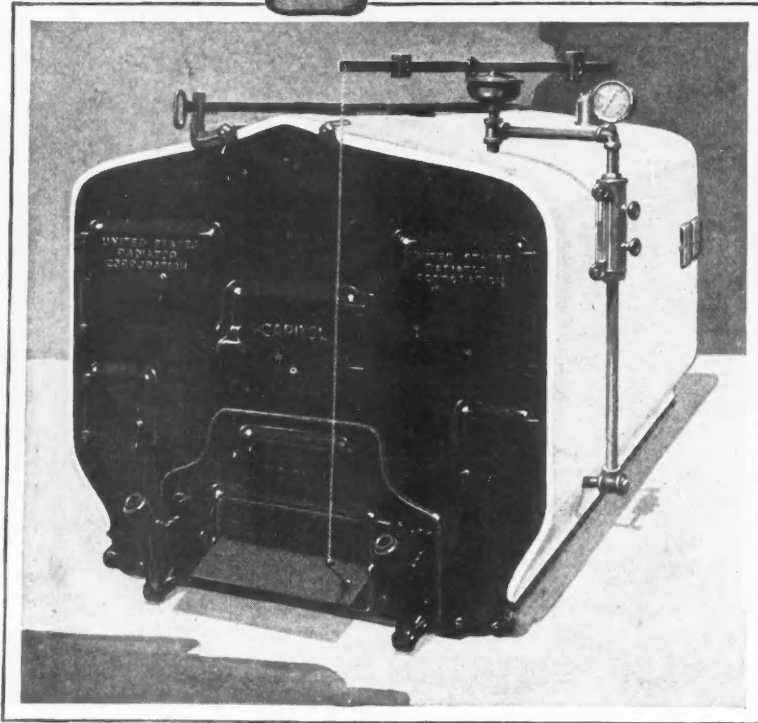

Capitol smokeless Boilers are recognized by architects, engineers and heating contractors as unquestioned standards of efficiency.

They conform to the smoke ordinance of any city in the nation and burn fuel with the utmost economy.

Like all Capitol Boilers they carry the broadest written guarantee in the heating field.

You can specify them with absolute confidence because we insist upon sharing the responsibility.

*UNITED STATES RADIATOR CORPORATION*  
General Offices, Detroit, Michigan

# Boilers



## Such Beautiful Clothes Closets!

To win the favor of the housewife, the modern builder must pay particular attention to the matter of clothes closets. Attractive, convenient closets have closed many a sale when the decision depended upon the woman's choice.

It will pay you well to send for the Knapé & Vogt booklets on Beautiful Clothes Closets. They show exactly how to increase closet capacity and convenience. How to save space and reduce building costs several hundred dollars on the average home by installing inexpensive Knapé & Vogt Clothes Closet Fixtures.

These informative booklets are yours for the asking. Return the coupon today.

**Any home old or new  
can have them**

Directions for modernizing old closets as well as plans for new ones are included in these booklets.

**Contractors!  
Builders!  
Home Owners!**

**Write for these two booklets**

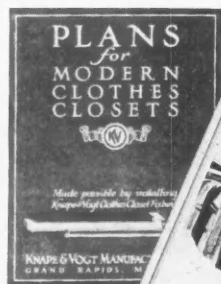

### This is all you buy

This simple inexpensive fixture is all you need to duplicate the beautiful closets shown in our booklets. Sold in hardware stores everywhere. If unable to locate dealer in your territory, order from us direct.

#### PRICES

14 inch .....	\$4.00	22 inch .....	\$5.20
16 inch .....	4.30	24 inch .....	5.50
18 inch .....	4.60	26 inch .....	5.80
20 inch .....	4.90	28 inch .....	6.10

**KNAPÉ & VOGT MFG. CO.**  
GRAND RAPIDS, MICH.

**KNAPÉ & VOGT MFG. CO.,**  
Grand Rapids, Mich.

Please send me your Free Booklet, "Beautiful Clothes Closets," and your free blue print folder, "Plans for Modern Clothes Closets," showing many different installation plans.

Architect       Contractor       Builder

Name .....

Address .....

City .....





### *Herringbone Doublemesh*

Smallest mesh.  
Least plaster waste.  
Most rigid of all  
metal laths, weight  
for weight.  
Made in painted,  
galvanized or copper  
bearing steel and in  
Armco Ingot Iron.

## Passing Years Cannot Mar Herringbone Interiors

**P**ASSING time deals kindly with walls of Herringbone construction.

Cracking, checking and loosening of plaster are unknown in spite of sudden jars or slow settling. The walls are solid—permanent—as enduring as the building itself. With this advantage the fire-resisting qualities of Herringbone construction must not be forgotten, nor the saving in plaster, where Herringbone is used.

Learn more of the real economy of Herringbone Doublemesh construction, the cost of which, including labor, is now practically on a par with that of ordinary wood lath. Our nearest branch will gladly send samples and full information. And ask for your copy of the new GF Herringbone Handbook—a splendid addition to your reference files.

### Other GF Materials:

*Self-Sentering*—A combined form, lath and reinforcement.

*Trussit*—A reinforcement for solid partitions.

*GF Expanded Metal*—A concrete reinforcement.

*GF Steel Tile*—For concrete floors.

*GF Steel Lumber*—Used in place of wood joists and studs.

*GF Steel Channels*—For fireproof partitions and ceilings.

*GF Peds*—Spot grounds for attaching trim to concrete and plaster.

*GF Duplex Bridging*—For wood joist floors.

*GF Waterproofings*—For concrete and masonry.

*Write for illustrated literature.*



## Herringbone Doublemesh Lath

THE GENERAL FIREPROOFING COMPANY, Youngstown, Ohio

### Branches:

New York • Chicago • Philadelphia • Boston • Cleveland • Los Angeles • St. Louis • Omaha  
Kansas City • Minneapolis • Milwaukee • San Francisco • Syracuse • Atlanta • Mexico City

Export Department: 438 Broadway, New York City

Cable Address: "Genfire-New York"



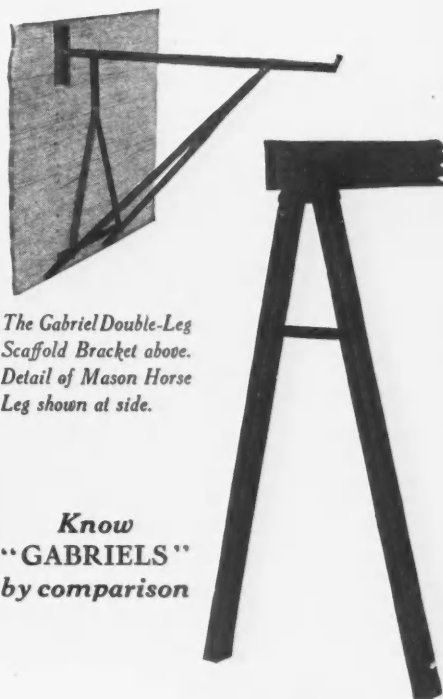
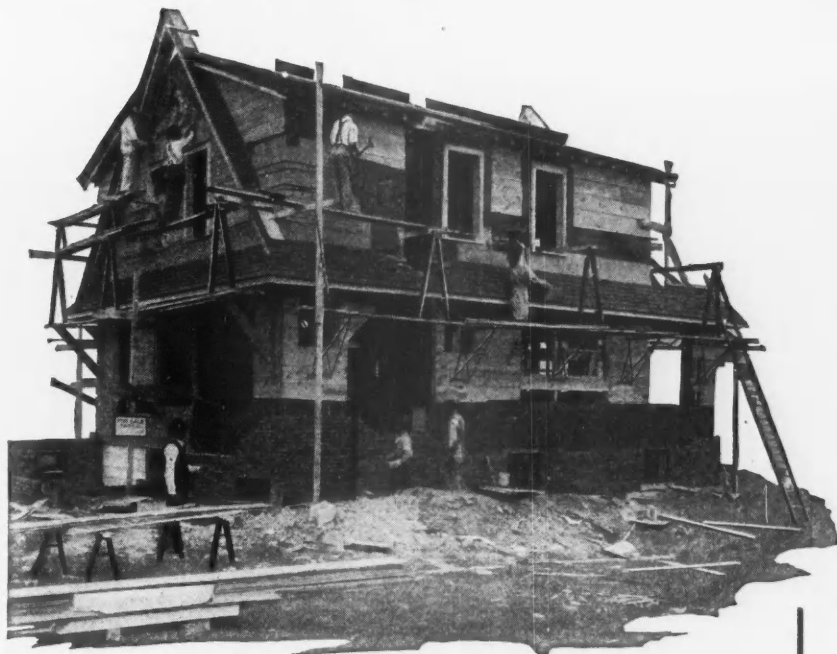

*The Gabriel Double-Leg Scaffold Bracket above. Detail of Mason Horse Leg shown at side.*

**Know "GABRIELS" by comparison**



*The Gabriel Bench Leg assembled. This is the modern, improved sawhorse.*



*The Durable Gabriel Coal Chute. Attractive and modern in every respect.*

## Modern Products for Modern Building

Advancements in building methods have been made successfully with modern Gabriel Bench Legs and Folding Scaffold Brackets. The clumsy wooden horse constructed on the job and the lumber scaffolding, costly in material and time, are now unnecessary. You can build more safely and quickly with these Gabriel Products.

Designed for maximum strength and durability Gabriel Bench Legs and Scaffold Brackets meet building needs perfectly and economically. The Bench Legs have solid steel jaws and wooden legs, are made in various styles and sizes, and are much more rigid than the old style horse. Gabriel Scaffold Brackets are of heavy rolled steel, joints securely riveted, making them particularly rigid and strong.

Contractors and builders will appreciate the economies of material and labor in these Gabriel Building Products. They are low in cost and through their folding feature make handling and transportation easy as well as reduce storage space to the minimum.

*Return coupon for information and prices.*

**GABRIEL STEEL COMPANY**  
Bellevue Ave., Detroit, Mich.

**GABRIEL**  
ROLLED STEEL  
PRODUCTS

**GABRIEL STEEL COMPANY**  
Bellevue Ave., DETROIT, MICH.

Send me information and prices on Gabriel Bench Legs, Scaffold Brackets and Coal Chutes.

Name.....

Address..... A. B. 3-25

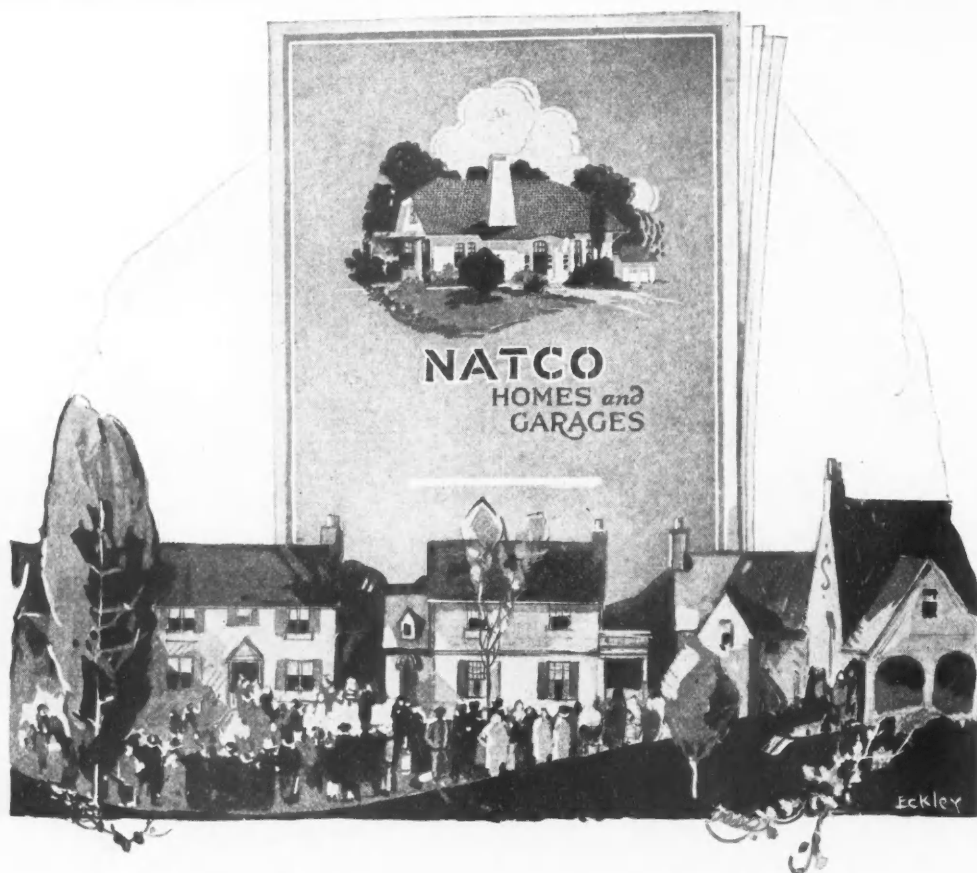

## THOUSANDS READ IT EVERY YEAR

That the Natco Home Book is a popular guide for home builders is a fact that has been proven over and over again every year for many years. Many of your own prospects are probably familiar with it.

The Natco Home Book is featured in Natco advertising every year in such magazines as House and Garden, House Beautiful, Good Housekeeping, American and Keith's. It is well illustrated with pictures and small floor plans of comfortable homes built of Natco Hollow Building Tile.

You should have a copy of the Natco Home Book on file. Write for the latest edition. It will be mailed you free.

NATIONAL FIRE PROOFING COMPANY

417 Fulton Building      Pittsburgh, Pa.

# NATCO

HOLLOW BUILDING TILE

FAIRBANKS-MORSE

HOME WATER PLANTS

120 gallons per hour capacity pump, 60-cycle motor, 2-gallon galvanized tank, complete  
**\$84<sup>75</sup>**<sub>list</sub>

200 gallons per hour capacity pump, 60-cycle motor, 35-gallon galvanized tank, complete  
**\$115<sup>00</sup>**<sub>list</sub>

Prices cash f. o. b. factory

Also larger sizes, for engine or electric drive, correspondingly low priced.

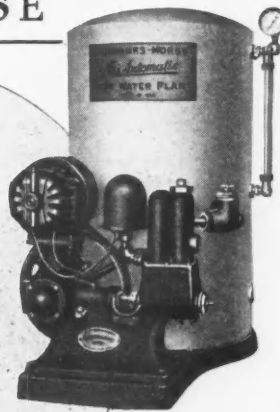

200-GALLONS PER HOUR PLANT

*It's Automatic!*

# Water Under Pressure for every home—old or new



Oftentimes the home owner who is building beyond the reach of city water mains does not realize what a simple matter it is for him to have water under pressure. He will welcome the reminder that he can have all the water he needs in bathroom, kitchen, laundry, garage, barn, watering trough—**any place**. Also, where a home is being remodeled, the suggestion of having water under pressure is a timely one.

meet all requirements. There is a plant for drawing water from any source—lake, spring, stream, shallow well, deep well, cistern. Furnished in both engine and electric drive. Operation of the electric plants is automatic—self-starting, self-priming, self-oiling.



And yet the cost of a Fairbanks-Morse Home Water Plant completely installed is less than half the usual assessment for a city water main. The operating cost is but a few cents a day.

Fairbanks-Morse quality is a matter of general information. You can be assured that it will reflect credit on your recommendation. An extensive advertising campaign in leading national publications is carrying still farther forward the prestige of the name.



Fairbanks-Morse Home Water Plants are made in a variety of sizes to



Let us send you our latest literature, including a valuable Home Water Plant Service Library of particular interest to architects and builders.

## FAIRBANKS, MORSE & CO.

Manufacturers  
 Chicago, U. S. A.



Pin This To Your Letterhead



Fairbanks-Morse Products—  
 "Every Line a Leader"

FAIRBANKS, MORSE & CO., Dept. H-3,  
 900 S. Wabash Ave., Chicago, U. S. A.  
 Send latest literature and complete information concerning Fairbanks-Morse Home Water Plants.

Name .....

Address .....

City .....

State .....

*Nationally Advertised*



## Just a thin blue thread —but it saves you money

The thin blue thread marker that runs in the center between the strands of H. & A. "Blue Heart" Manila Rope adds nothing to its strength. Yet it is a symbol of long-wearing rope.

It is your assurance when you buy, of getting exceptionally good rope—rope that will prove its worth in long wear. Cheap rope, as users everywhere are coming to realize, is a poor buy in the long run. It wears out quickly and costs time and money to replace.

The best grade manila rope, on the other hand, more than pays for itself in long, dependable service. Make sure of getting such rope this way before you buy.

Untwist the strands. If you find a thin blue thread marker—the "Blue Heart"—running in the center between the strands, then you may be sure of these facts.

### *What the "Blue Heart" signifies*

The "Blue Heart" marker means that the rope is genuine H. & A. "Blue Heart" Manila Rope spun from high grade, pure selected manila fibre by rope makers with

over half a century's accumulated experience.

The "Blue Heart" marker means that the rope is genuine H. & A. "Blue Heart" Manila Rope spun from high grade, pure selected manila fibre by rope makers with over half a century's accumulated experience.

It means also that in any size, on any job, the rope will wear longer and deliver without fail the strength you have a right to expect. For the selected fibres of H. & A. "Blue Heart" Manila Rope are drawn, spun, laid and properly lubricated so as to insure the smooth working of every fibre, yarn and strand.

Buy rope scientifically. Know beforehand what you are getting. Untwist the strands and look for the "Blue Heart"—our registered trade mark that assures you of dependable rope value.

### *Guarantee*

H. & A. "Blue Heart" Manila Rope is guaranteed to equal in yardage and exceed in tensile strength the specifications of U. S. Government Bureau of Standards. Any H. & A. "Blue Heart" Manila Rope found not to be as represented will be replaced.

**The Hooven & Allison Company**

*"Spinners of fine cordage since 1869"*  
Xenia, Ohio



## **H&A "Blue Heart" Manila Rope**



# Selling Houses

TODAY America leads the world in plumbing practice and the conveniences that it provides. Twenty-five years ago it was a fine house that had a tin bathtub with running water. Today, new houses are literally planned and built around the plumbing installation. It is within the experience of every builder that many people liking a house have decided to buy or not to buy, just because of the baths and plumbing arrangements.

Experience is teaching people that the plumbing if not properly designed and installed, may represent a big and continuous expense. If to this experience educational and advertising writings are added, it becomes apparent why buyers of houses examine in a more or less expert fashion the quality of the plumbing work.

In selling houses you will find the best brass pipe—Alpha Brass Pipe—a great help. It has all the advantages of ordinary good brass pipe over iron and steel pipe, plus other advantages. It bends and threads easier than ordinary brass pipe which is an advantage for the plumber. It has more copper which makes it more durable than ordinary brass pipe even under adverse conditions. It has a better surface finish that takes nickel plating better than ordinary brass pipe.

Alpha Brass Pipe is a high spot in the construction of any house which includes it. If properly installed it will never give trouble but will be a continual source of satisfaction. If you want to know why Alpha is the best pipe, let us send our book—Alpha Brass Pipe.

CHASE METAL WORKS, Division of Chase Companies, Inc., Waterbury, Conn.

STOCKS: Chase Companies of New Jersey Newark Ohio Chase Company Cleveland Chase Companies of California San Francisco Los Angeles

OFFICES: Boston New York Philadelphia Rochester Pittsburgh Chicago St. Louis Atlanta

Members Copper and Brass Research Association

## ALPHA Brass Pipe

**ALPHA BRASS PIPE** contains only Alpha crystals. It is a fine-grain, dense, ductile and tough metal. It makes perfect bends, threads and cuts easily and offers even greater resistance to corrosion than ordinary brass pipe. Full details in our Alpha Brass Book.



CHASE METAL WORKS, Waterbury, Conn.

Please send me free of charge a copy of your book on Alpha brass.

NAME \_\_\_\_\_

FIRM \_\_\_\_\_

POSITION \_\_\_\_\_

ADDRESS \_\_\_\_\_

*"Millions of California Pine window sash and frames are in use in American homes."*

## Window wisdom



Window sash and frames must withstand the extremes of weather wear, plus handling and friction—a most exacting demand upon the wood of which they are made. Accurate workmanship is paramount; and it is essential that this accuracy be preserved during the life of the sash and frame.

Millwork accuracy depends primarily upon the texture of the wood used. Soft-textured California Pines are naturally qualified for precision millwork. They cut easily, either with or across the grain, without splitting. They surface smoothly on four sides. Their uniformly even grain allows the

cutting tool to produce sharp edges, which cast the contrasting shadows that accentuate the design of the building.

California Pine sash and frames preserve the structural form and design of the window unit, because these pines have the minimum tendency to expand and contract. They withstand the severe strains of opposing elements, as, for example, zero temperature outside the home, and 70 degrees inside; or, when the outside window woodwork is rain-beaten, while the inside is dry.

The very light weight of these

pinnes makes sash operation easy, at the same time lessening the cost of balance weights, or, reducing the strain on mechanical sash balances.

Sash and frames are painted inside and out. Paint protection adds to the natural wearing qualities of wood. California Pine window parts paint perfectly, their smooth surfaces readily take the paint and hold the protective coating tenaciously. The light, natural color of these pines permits any exterior color treatment, and the finest interior window finish—with assurance of lasting, unblemished beauty.



Send for this free illustrated booklet

Sash and frame manufacturers find the qualities of California Pines parallel those of the Eastern white pines, the supply of which has been largely depleted by past demand. Many of these manufacturers now use California Pines, the supply of which is ample to meet the demands of the next two centuries.

## California WHITE & SUGAR PINE

Manufacturers Association

CALL BLDG., SAN FRANCISCO

Also producers of CALIFORNIA WHITE FIR

CALIFORNIA DOUGLAS FIR    CALIFORNIA INCENSE CEDAR

Mr. Albert Dahl and his DUNTILE manufacturing plant at Elwood City, Pennsylvania, in which he is making a striking success.

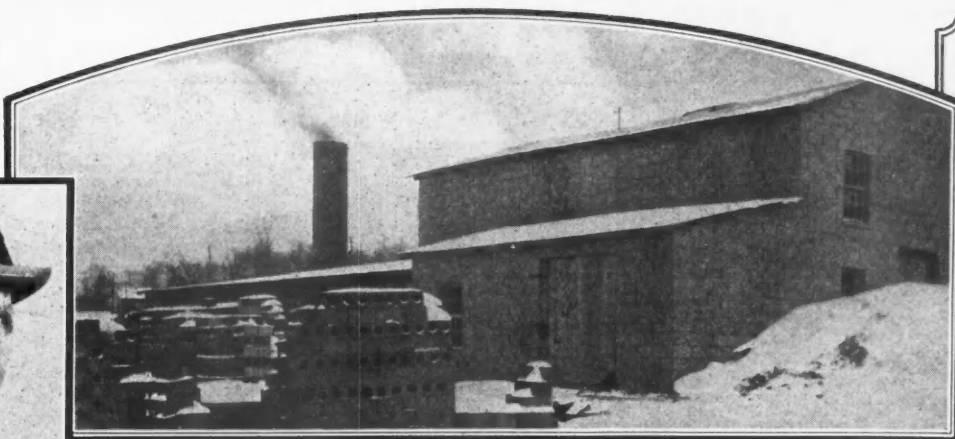
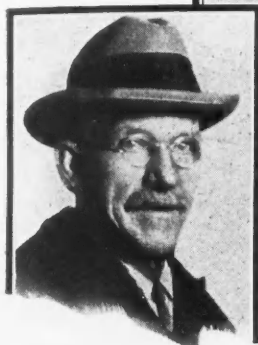

Out of every walk of life

# The Contractor Triples his Profits!

Nearly 50% of the Many highly Successful Manufacturers of

## DUNTILE

formerly were Contractors



This church completely built of DUNTILE, is typical of the many larger structures for which Albert Dahl & Son are supplying the materials at a cost approximately 30% less than brick.

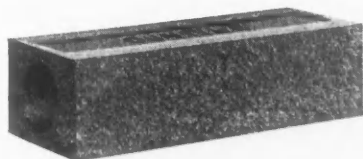

DUNTILE, the perfected concrete building unit, combines the advantages of light weight, great strength, unusual insulating and fireproof quality, and extreme economy. Several standard sizes made on one production machine.

**I**F you would like to consider the possibilities of a thriving, steadily growing manufacturing business of your own, you will find real food for thought in the splendid success Albert Dahl & Son are making in the manufacture of DUNTILE.

### Formerly a Successful Contractor

As an example of what calibre of men become DUNTILE manufacturers, consider that Mr. Albert Dahl is one of the old school of master craftsmen—thorough, painstaking, conscientious. As a general contractor, and later specializing in road contracting, he was very successful. Then DUNTILE came his way and aroused in him the enthusiasm that only a builder who knows the game from A to Z could have for this vastly superior concrete building unit.

Having decided that his big future lay with DUNTILE, Mr. Dahl disposed of all his contracting machinery at a sacrifice, and in April, 1924, he and his son (a recent university graduate) started operations in their new DUNTILE plant.

### 40% Greater Volume Than Expected

Very recently Mr. Dahl stated that while they had expected big things of DUNTILE, their first nine months of operation had brought them 40% more business than the high mark set for themselves. Such achievement is more readily understood when you consider this:

### DUNTILE Reduces Permanent Building Costs to Level of Frame

Everyone is interested in lower building costs. And DUNTILE not only reduces costs but it opens the way to better construction. It is perfectly suited to the complete construction from foundation to roof of every type building.

### 200 Successful Plants Point Way for YOU

This announcement can be valuable to you in only one way—by causing you to investigate fully the possibilities of a DUNTILE plant of your own. Fortunately that is very simple for the experiences of more than 200 others have provided an immense fund of FACTS concerning the unlimited market open to you—the many great structural advantages of DUNTILE—the wide margin of profits over all competition—the amazing manufacturing efficiency of the Standardized DUNTILE Plant—proven facts that are yours for the asking. Merely sign and mail the coupon. But by all means do it NOW; do not wait until someone else has taken advantage of the opportunity that today is YOURS.

**W.E. DUNN MFG. Co.**

415 West 23rd St.,

Holland, Mich.

Show me

through your book "BASIC FACTS" the facts and figures that prove how average ability and some capital wins manufacturing independence for those supplying DUNTILE in each community. Also show me how I can manufacture DUNTILE in a plant of my own at a profit of 30% to 60%.

Name.....

Street Address.....

City..... State.....

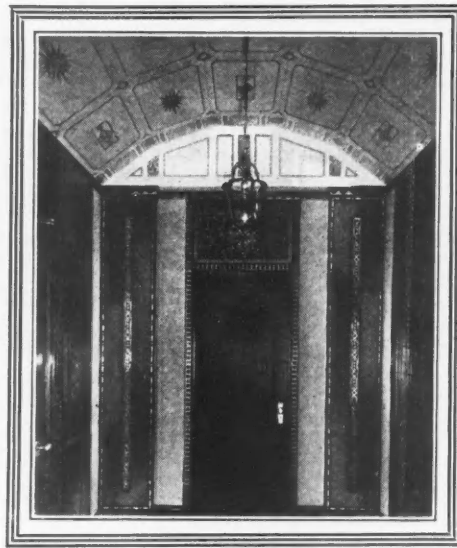

*An example of artistic Vitrolite decoration in rich colors, designed by the Service Bureau of The Vitrolite Company. Architects may view this exhibit at our New York Offices, Pershing Square Building, 42nd Street at Park Avenue.*

## This foyer has unusual walls and ceilings

**W**HAT do you think of a standard material for permanent surfaces which has absolutely no limitations in its application or in its decorative effects? That is what Vitrolite offers.

It comes in any size you may wish to specify up to 5 feet by 10 feet.

The slabs vary in thickness from 5-16 of an inch up to one inch.

In marble you are limited to  $\frac{7}{8}$  of an inch as a standard thickness. In Vitrolite you use greater thickness only where it is needed. For instance, in standard ashlar construction, the thicknesses vary from 5-16 of an inch to 7-16 of an inch, depending upon requirements.

It is in the plain colors, such as pure white that Vitrolite is most commonly used in bathrooms, kitchens and toilets. Besides white [and let us say that the quality of Vitrolite white is of rich purity] you have black that is like jet, ivory that looks like polished ivory, and a soft grey, almost a neutral tone, which lends itself to smart color decorations as used in Tea Rooms and Restaurants.

Upon this material, as a border or design, may be placed any color or

combination of colors imaginable in any design. For example, any of the formal motifs of the periods can be carried out in colors. Or, as in one instance just finished, a panel has the colorful design of a Chinese pheasant. Another has the family crest reproduced perfectly.

In connection with the use of designs and colors The Vitrolite Company maintains a Service Bureau prepared to give technical service. Besides stock patterns of decorative work, special designs are prepared at very little expense, because the Vitrolite processes are so simple. Not only does this department prepare suggestions for appropriate treatment, but they are equipped to carry out your *own* suggestions even to the smallest detail.

To insure perfect installation, Vitrolite is installed by our own organization, which is expert in this work. They use a special cement which acts as a cushion, taking care of impact or change in temperature.

Where but in Vitrolite can you get a surface material that is permanent—that will never craze like tile or grow discolored and perish the way marble does?

**VITROLITE**  
Better Than Marble

### THE VITROLITE COMPANY

Offices: 133 West Washington Street, Chicago

Atlanta, Baltimore, Brooklyn, Boston, Buffalo, Cincinnati, Cleveland, Columbus, Dallas, Denver, Detroit, Kansas City, Los Angeles, New Orleans, New York, Omaha, Philadelphia, Pittsburgh, Portland, Roanoke, San Francisco, Seattle, Springfield, Mass., St. Louis, St. Paul, Tulsa, Montreal, Toronto, Havana, London, Manila, Osaka, Mexico City, Shanghai

Factory: Parkersburg, West Virginia







# The Man Who Stood Still

**T**HE man who stood still! You pass him on the street every day. If you take one moment now, you can easily recall at least one man who reminds you of this picture. Day after day he follows in the same groove. In good health and in bad he has got to work. Growing older and older, he sees ahead no relief from the ceaseless toil that he has known all through his life. There is no opportunity for him to cease for a single day the everlasting "humdrum" that he has known for so long. He is the man who stood still.

When he had the chance he failed to seize it. He allowed other men, no smarter, no abler, no better than he, to crowd him out. One by one his fellow workers passed him by to better and more profitable work. They left him always standing on the threshold of success. But they left him behind. He heeded not the beckonings of opportunity. He is the man who stood still.

And now at sixty, at seventy or at eighty years you may see him any day if you care to look—a good carpenter, a good builder, a good contractor perhaps—but that's all; good in the sense that he can do certain things simply because he has done the same thing over and over again—but not good enough to try the new difficult work, the modern up-to-date jobs; the kind that pay good money. No, he cannot do these things—he never learned how. He is the man who stood still.

You don't want to stick to the plane, the saw and the hammer all your life. If you are a contractor or a builder don't you want bigger work than just barns, sheds and now and then a house or two?

If you are a draftsman, an apprentice or assistant in an architect's office you don't want to remain in your present position any longer than you have to; you want to make your present work the stepping stone to a bigger position, which will be your life's work.

You don't want to stand still and see your friends step ahead to enjoyable, well paid, independent work simply because they "snap up" the same opportunities, the same chances that are offered you. It is the natural ambition of man to want to keep up with his fellows.

The only way that you or any other man can keep up is through study—study of your chosen work. If there is a certain part of your work that you don't thoroughly understand then some time when that kind of work has got to be done some other man is going to step up ahead of you and do it. He learned how. **KNOWLEDGE IS THE GREAT LEVELER.** There is no true independence where there is lack of training.

You have the chance now within your grasp to get this necessary training. This advertisement is an absolutely direct appeal to you. No matter how good a position you hold now—no matter how much work you are getting—no matter how well you are paid for it—this advertisement holds as much interest for you as the man who is actually looking for work.

At no risk to you—without the slightest obligation on your part—we offer you the really great opportunity of perfecting yourself in your life's chosen work. Don't pass this page by until you have made up your mind to give the rest of this advertisement careful study. Look at the picture again at the top of this page—look at it carefully. You owe it to yourself and to those who may be dependent upon you to take advantage of every possible chance for bettering yourself.

*You cannot afford to be the man who stood still*

## Radford's Cyclopedia of Construction

# FREE

We will send free of all extra cost three plan books of over 300 plans of buildings One complete set of blue printed working plans and typewritten specifications of one of the houses illustrated in the three books of plans. We will also send with this Cyclopedia one year's subscription (12 numbers) to the American Builder, the world's greatest building paper.



# He Waited too Long

"If I only had this set of books twenty or thirty years ago, they might have changed my whole life. The knowledge in the big CYCLOPEDIA would have enabled me to increase my earning power, to take on big work, paying big money, and possibly have helped me to make a fortune in the building business."

**H**UNDREDS of letters like the above have come to us, breathing between the lines the same pathetic story of regret—showing how hard it is for the untrained man to really get ahead in life. The opportunity is yours NOW, and the way is easy. Don't wait too long. Don't wait at all. Read the terms of our NO-RISK, Guarantee Offer over again, and sign and mail coupon today. You risk absolutely nothing, and you will reap the benefit ever afterward. The building trade has as much use for an exclusive library relating to carpentry, building and architecture as the professional men, such as lawyers, doctors, ministers and teachers have for their particular libraries, to which it is necessary for them to refer and without which they could not continue their practice. The building trade has more possibilities and the successful contractor and builder can, with the use of books, make more money and attain a higher position in the community than the average professional man. The line which has heretofore been drawn between the professional man and the mechanic is just about wiped out and it has been done by the use of books.

## SPECIAL FREE PREMIUMS

IF YOU ORDER AT ONCE

If we receive your order at once, we will send with this Cyclopedia one year's subscription (12 numbers) to the American Builder, the world's greatest building paper. We will send free of all extra cost, one complete set of blue printed working plans and typewritten specifications of any of the houses illustrated in three Books of Plans, which we also send to you free of cost, so that you may make your selection. These plans and specifications are as complete as those charged \$50.00 to \$75.00 for by many architects. These plans will be very valuable to contractors, builders and daughtsmen. The only reason we can offer to do this is because we have the largest architectural establishment of its kind in the world, and are able to produce these complete blue printed working plans and specifications at the very lowest possible price, and to the purchasers of this big Cyclopedia we are willing to give the benefit. Without American Builder \$1.00 less.

We make this liberal offer because we want you to have our Cyclopedia, and we believe by having it in your hands we will have a greater opportunity of disposing of others in your locality, and it is with the distinct understanding that if it is entirely satisfactory, you will write us a letter and assist us in making other sales.

Our special price to you for advertising purposes is only \$37.50, and our liberal terms are only One Dollar down and \$3.00 per month until the amount is paid. We give you five days to look the books over and see if they are entirely satisfactory. If you conclude not to keep them, we will refund your money and pay the express charges both ways. Order today. Fit yourself at once to increase your earning power.

**The Radford Architectural Co.**

1827 Prairie Ave., Chicago, Ill., U. S. A.



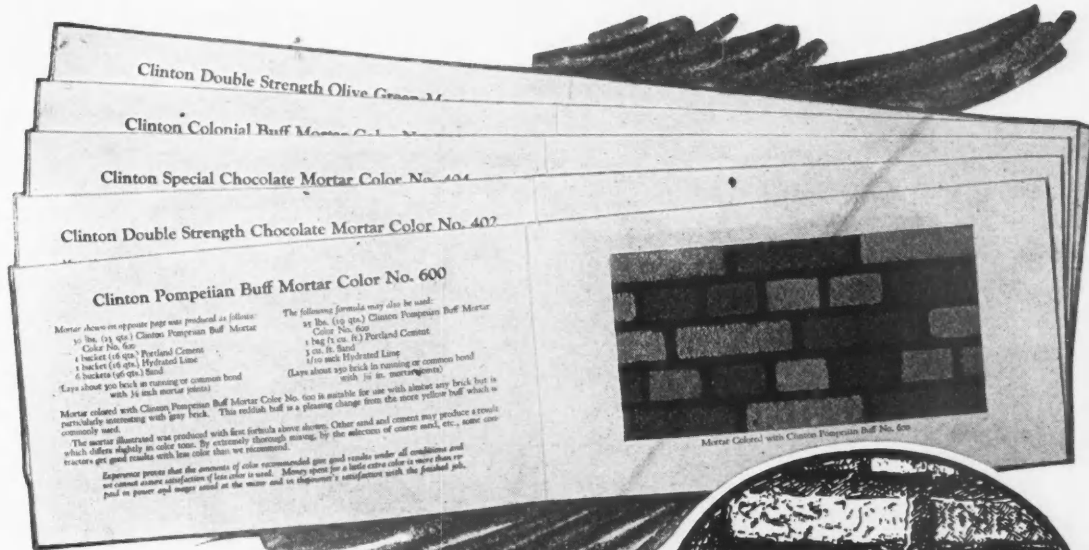

Send for this information about "The Vital Fifth"

*The Vital Fifth*

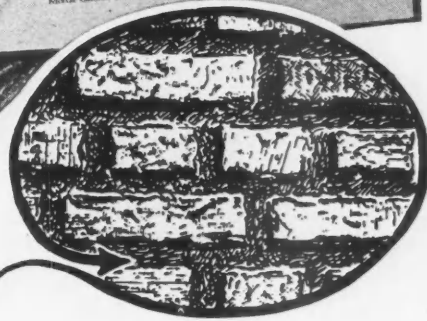

## 1/5 of Brickwork is Mortar

"THE VITAL FIFTH" can either make or mar the appearance of a brick building. A well chosen shade of color in the mortar joint effects pleasing harmony in the whole wall surface, and is just as essential as the color and quality of the brick themselves.

Furthermore, the character of the Mortar Color must be dependable. It must be exactly uniform from bag to bag and produced by a house with the reputation that only long manufacturing experience can give.

Make sure that you use absolutely dependable Mortar Colors. Clinton Mortar Colors are dependable. Careful study of raw materials, painstaking research, and generations of manufacturing experience—years of service to the building public are behind every ounce of Clinton Mortar Colors.

For practical and detailed information on the choice and use of mortar colors, address The Clinton Metallic Paint Company, 99 Clinton Road, Clinton, N. Y.

# Clinton Mortar Colors

Nature's Permanent Colors—Made since 1887



# A practical, up-to-date book that develops business



Published in February of this year. Deals with the latest and best practice in making cement improvement around home, farm or business place. 112 pages, freely illustrated.

Just the thing you need in explaining your ideas to the property-owner.

Any ALPHA CEMENT Dealer can give you this valuable book, also other helpful ALPHA Bulletins and Service Sheets. Ask for your copy.

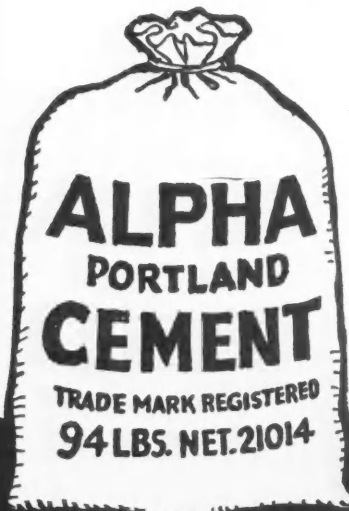

**Alpha Portland Cement Company**  
EASTON, PA. CHICAGO, ILL.

New York Boston Philadelphia Pittsburgh Baltimore  
St. Louis Battle Creek, Mich. Ironton, Ohio

## use ALPHA cement



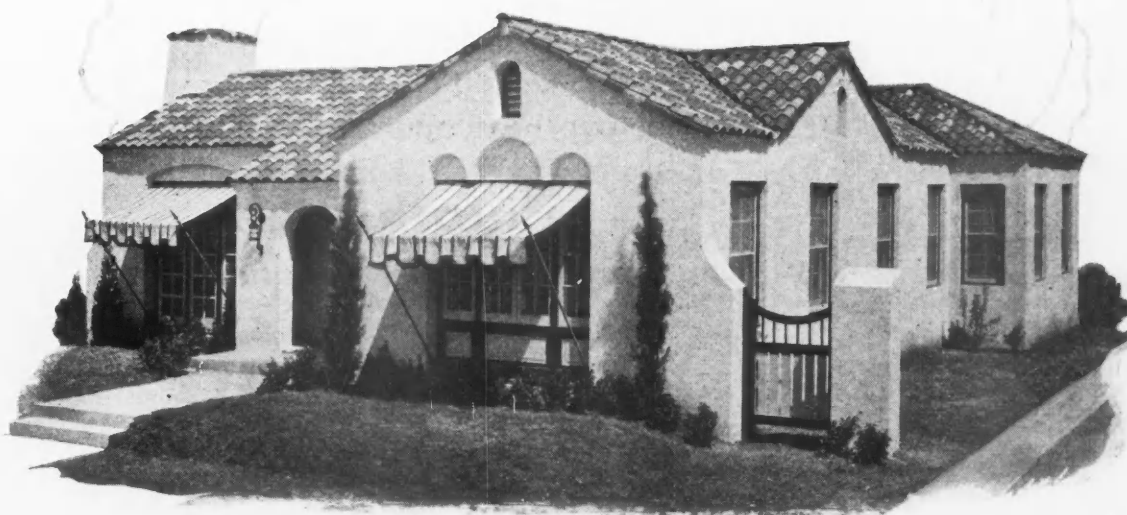

## No Home Too Small for Tiles

**T**HE old-fashioned idea that tile roofs are only for pretentious homes is rapidly disappearing. Nowadays it is not uncommon to see even the modest bungalow distinguished by a roof of IMPERIAL Roofing Tiles. Because such roofs last forever without repairs, their slightly higher first cost is unworthy of serious consideration. Moreover, they greatly increase the selling value of any home.

The attractive dwelling pictured above is that of Harvey McQueen, Architect, Dallas, Texas. Its colorful roof of IMPERIAL Roofing Tiles harmonizes delightfully with the Spanish type of architecture, and will provide absolute protection from fire and the elements for generations to come.

# IMPERIAL Roofing Tiles

LUDOWICI-CELADON COMPANY

104 South Michigan Avenue • Chicago  
565 Fifth Avenue • New York



# SANDS LEVELS

## Strong and Light!

These aluminum levels have greater strength with less weight. The lenses and spirit-tubes are made of a non-brittle glass that withstands rough usage. And you can use a Sand's all day without tiring. It's ideal for overhead and arm's length work.

## Plumb Right

Window frames and doors are *plumb* when you use a Sand's. So are walls and foundations. Sand's accuracy is built-in by factory experts.

## Sealed Tight

The spirit-tubes are set and sealed immovably. Sand's accuracy is permanent. You can depend on it. Protecting lenses form a double seal that is dust-proof and moisture-proof.

## The Choice of Master Craftsmen

Sand is the "buy"-word for levels with careful workmen everywhere. Sand's Levels have made good on the job for thirty years. They always tell the truth.



*At Good Hardware Stores Everywhere*

"Sand's Levels Tell the Truth"

# SANDS LEVEL & TOOL CO.

5847 Fischer Avenue - - Detroit, Michigan

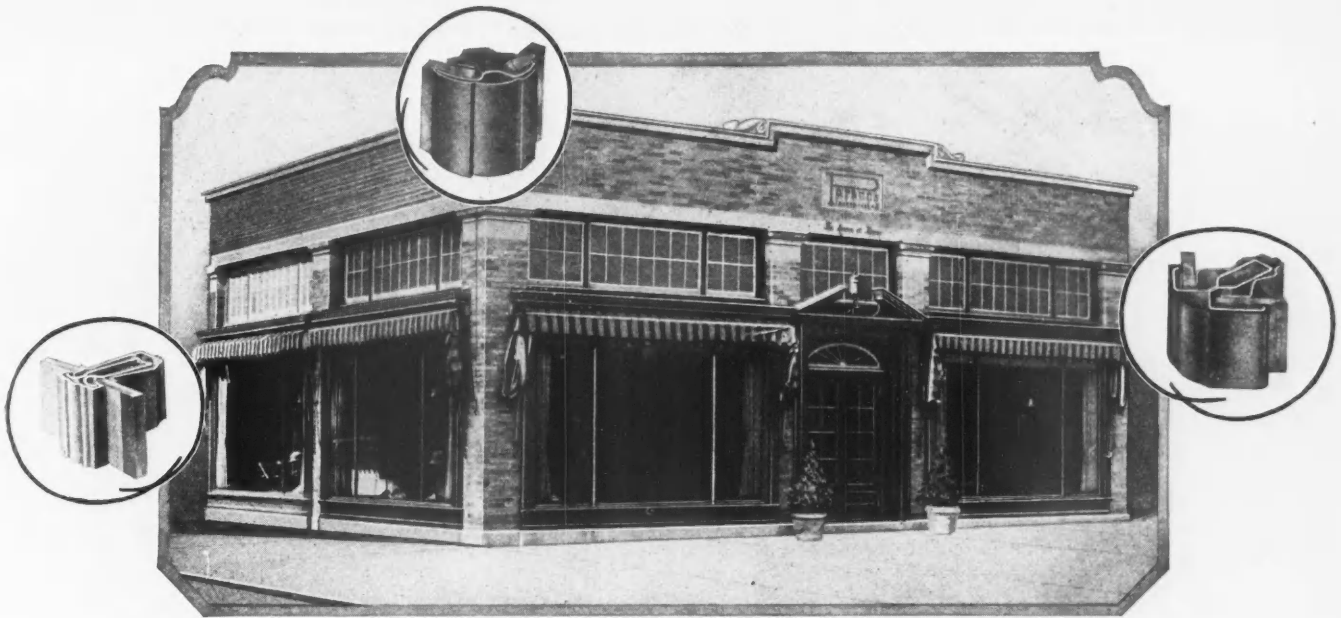

## The Backbone of Steel in Brasco Copper

Behind the glittering copper of the Brasco Store Front is built-up **strength** for super-safety. Every division, corner and reverse bar is reinforced by heavy drawn steel, fabricated into a continuous unit within the heavy gauged copper mouldings. **Only the copper is visible.**

This steel structure is not merely made up of plain steel bars. Each member is specially formed into a shape that will most effectively absorb the direct and reacting stresses to which the bars are subjected. It is an integral part of the design, conforming to the shape of the bar itself.

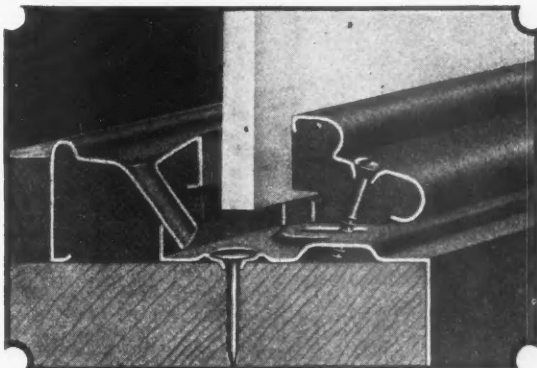

Brasco Sash, showing the wide grip on the glass and the indirect screw pressure method of fastening. *Brasco sash is also available in the "500" All Copper Construction.*

Each of these bars employs the unusually **wide grip** on the glass—firm, supple and uniform—that distinguishes Brasco sash—also the Brasco principle of **indirect screw pressure**, both of which combine to insure absolute glass safety.

Brasco strength and safety are basic. Its simplicity makes it easy to install with minimum labor and mill work. Its effective drainage and ventilation features make it perfect for display. Its permanent architectural beauty harmonizes with any exterior treatment.

Handling Brasco gives any contractor the nearest possible approach to a 100% store front proposition. Its quality reputation is firmly established—its merits admittedly superior—its price right. Brasco brings quick orders, assures repeat business, makes steady substantial profits. Send the coupon below for free information on how Brasco can help **you**.

**BRASCO MANUFACTURING CO.**  
5029 South Wabash Avenue Chicago

**Brasco**  
**COPPER STORE FRONTS**

AB 225

**Mail this coupon  
for the money-making  
Brasco story**

BRASCO MFG. CO., 5029 South Wabash Avenue, Chicago.  
Send me your free information on profitable store front work.

Name \_\_\_\_\_  
Address \_\_\_\_\_



Standardized  
Small Tool  
Equipment  
Saves  
Maintenance  
Costs.

# Sterling's "Most Economical"

C. H. Everitt  
Buffalo, N. Y.

Gentlemen:

Replying to your letter of the 9th inst, I am pleased to advise you that I have been using the Sterling Wheelbarrows and carts for a number of years, due to the fact that they have given entire satisfaction under the most severe use.

I have experimented with several makes of Wheelbarrows in the past few years, but find the Sterling the most economical as to interchangeability of parts, and self lubricating wheels, and general sturdy construction has convinced me that there is no better equipment in this line on the market and I now have between sixty and seventy five in use at all times.

Very truly yours,

*C. H. Everitt*



Bulletin 39 tells the story  
Ask for it

They Balance Well,  
Wheel Easy and  
Please the Wheeler.  
All Parts of the  
Sterling Barrow are  
Interchangeable,  
Simple and Durable.

## STERLING WHEELBARROW COMPANY

STERLING ON A WHEELBARROW MEANS MORE THAN STERLING ON SILVER

Milwaukee

MANUFACTURED FOR THE EUROPEAN MARKETS BY  
STERLING FOUNDRY SPECIALTIES LTD. STERLING WORKS, BEDFORD, ENGLAND

Wisconsin



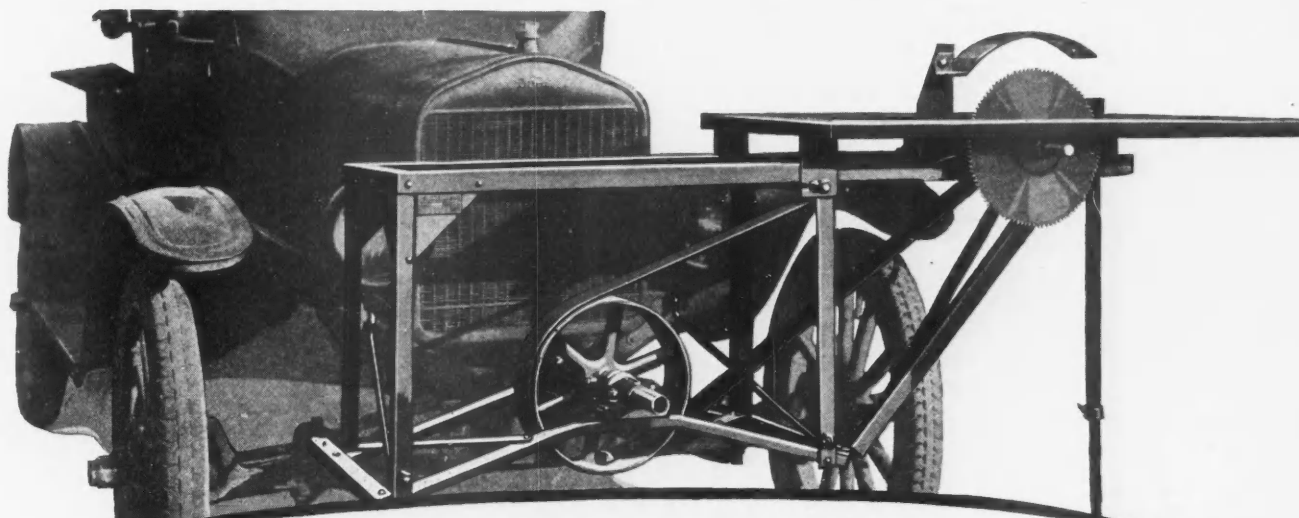

**Saves This Builder \$200<sup>00</sup> \$325<sup>00</sup>  
On Each House**

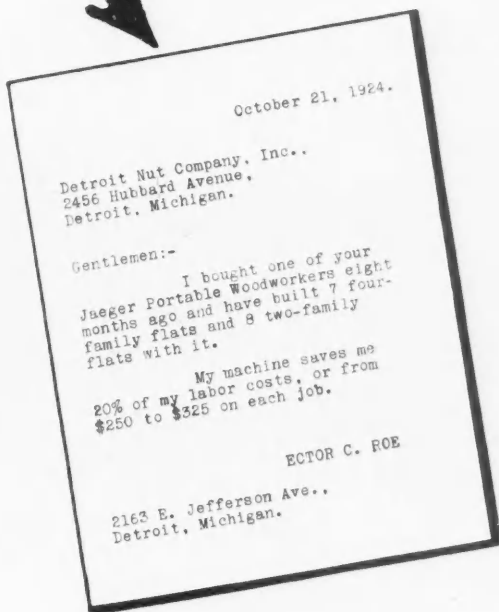

The JAEGER Portable Woodworker, operated by your **Ford** does any kind of sawing quicker and better than it can be done by hand—it cuts compound angles, rips quickly and easily—cuts studding, joists, rafters, sheathing, bridging, etc.,—the same power that hauls your lumber to the job will saw it on the job as you want it and when you want it—Your **Ford** is your power plant—**use it.**

The JAEGER Woodworker can be installed on any model **Ford** in a few minutes. It is rugged, strong, durable and economical to operate. It is connected directly to the crankshaft and the power is not transmitted through the transmission or rear wheels.

The line of JAEGER Portable Machines consists of Woodworkers, Portable Power-take-offs, Generators, Pumps—every one **time** and **labor** saver.

*If Your Ford Dealer Can't Supply You,  
Write to Us for Complete Information.*

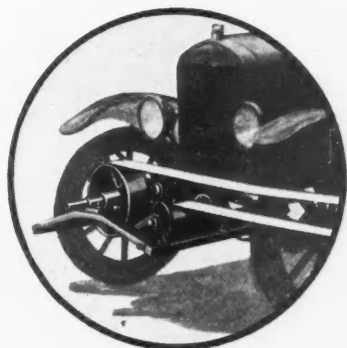

**POWER TAKE-OFF**

Mix your concrete. Mix your plaster—operate your pump—operate your hoists—for all power jobs.

**DETROIT NUT COMPANY, Inc.**

Manufacturers of

**Jaeger Portable Machines**

Office and Works, Hubbard Avenue, at Michigan Central R. R.

**DETROIT, MICHIGAN**



# SMITH MIXERS

## Exchequer Dam Being Built With Powerful "Smiths"

Bent Bros., Inc., are using three Smith 56-S Tilting Mixers in the construction of the Exchequer Dam and Power House in the Merced Irrigation District, California. Some idea of the bigness of the job is given by the following figures.

The proposed height of the dam is 326 ft., its length 950 ft., and its width at base 221 ft. A storage capacity of 280,000 acre feet is planned and two power units will be erected, each capable of producing 16,750 hp. In all, the work will require 380,000 cu. yds. of concrete, all of which will be poured by the three Smith 56-S (two-yard) tilting mixers.

It is on just such jobs as this that big Smith Tilters excel. Their accurate, speedy mixing; their fast discharge; their self-cleaning double-cone tilting drums, sufficiently large to permit the use of small size boulders when desired; their centralized control; their dependability, long life, low cost of operation and maintenance—all these are factors that make Smith Tilters standard equipment for the big job. Send for our latest bulletin.

### The T. L. SMITH COMPANY

1026 32nd Street, Milwaukee, Wis.

Sales Offices and Service Stations in all Principal Cities

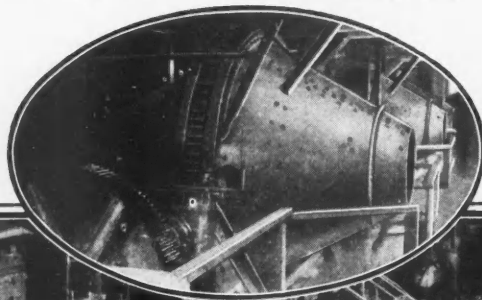



**John Gamble  
Was a Lucky Man!**

**His Contractor used Union Metal  
Columns—that Last a Lifetime**

The contractor for Mr. John Gamble's fine residence on Happy Hollow Boulevard, Omaha, didn't take any chances when it came to porch columns.

He bought Union Metal: the Columns that add hundreds of dollars to the value of any building on which they are used.

Made of *copper bearing* steel. Weatherproof, Fireproof, Everlasting. Diameters 8" to 42"—heights 5' to 42'.



**"Colonial Entrances"**  
—A valuable book prepared by architects for everyone interested in better building at lower costs. Sent FREE upon request.

**THE UNION METAL MANUFACTURING CO.  
CANTON, OHIO**

**UNION  
METAL COLUMNS**

WHEN WRITING ADVERTISERS PLEASE MENTION THE AMERICAN BUILDER

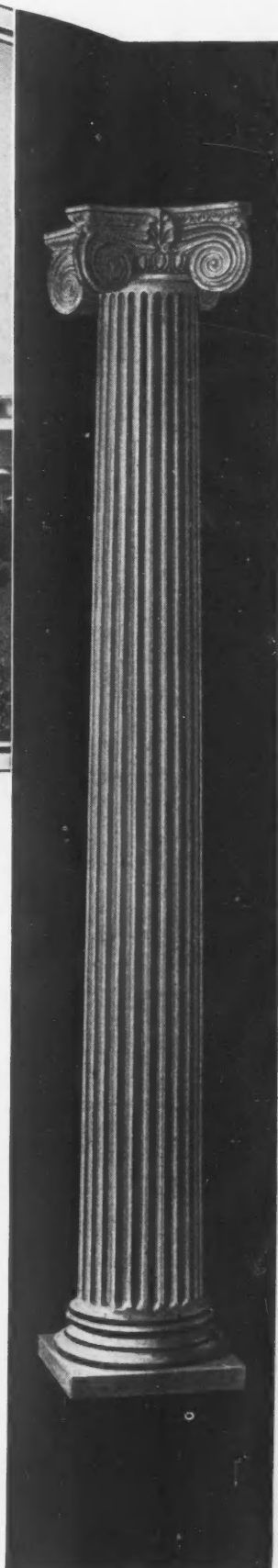

Design No. 237, Modern Ionic Columns and pilasters shown on residence of John Gamble, Omaha, Nebraska. Architect, Charles W. Rosenberry. One of ten classical designs.



# ROME BRASS PIPE

An attractive home in  
Glencoe, Illinois.  
Messrs. R. C. Hunter  
& Bros., Architects.  
Rome Seamless Brass  
Pipe specified.



**For the small house—  
as well as mansion or  
office building**

What a satisfaction it is for your client to know that decades hence, the little home will still retain its original charm—the water pipes will not leak or need repairing—alterations to floors or walls will never be caused by leaking pipes.

Many people who know the superiority of brass pipe over corroding iron or steel pipe, do not know how little additional it costs to provide permanency in hot and cold water lines.

On the average, three-quarters of one percent added to the original cost of the building will pay for Rome Seamless Brass Pipe in all hot and cold water lines. The saving which results from eliminating repairs and renewals is so great as to dwarf into insignificance the merely nominal increase in original cost.

Specify Rome Seamless Brass Pipe and secure permanency of plumbing lines, freedom from rust-clogged pipes, and protection of interiors from leaking pipes due to corrosion.

Let us send you this  
**ROME BRASS PIPE  
ESTIMATING CHART**

It contains approved  
methods of calculating  
required quantities of  
pipe for both hot and  
cold water installa-  
tions.



**ROME BRASS AND COPPER CO.,**  
Rome N. Y.

Branch Warehouse: 3649 So. Racine Avenue, Chicago, Ill.

Member Copper and Brass Research Association



[ BRILLIANT . . . . . DIFFUSIVE . . . . . BEAUTIFUL ]



NEW ST. LOUIS UNIVERSITY HIGH SCHOOL, St. Louis, Mo. Barnett, Haynes and Barnett, Architects, St. Louis, Mo.  
*Diffusion of light through Tapestry Glass in chapel. Design appears in lines of clear glass, field sand-blasted.*

## TAPESTRY GLASS

*Adds beauty and dignity wherever used*

MANY notable architects have been quick to recognize the unique qualities of Tapestry Glass. Wherever the maximum of clear, brilliant light is necessary and privacy is desirable, Tapestry Glass offers many possibilities for unusually beautiful effects.

Tapestry Glass has all the strength, purity and clarity of the finest plate. And by a special, exclusive process the surfaces are given a smoothly rounded texture, not unlike fine fabric. These surfaces collect and diffuse light in a brilliant flood, yet they obscure vision.

Plain Tapestry Glass may be easily and inexpensively decorated with designs conforming to any architectural plan. These may be permanently chipped, ground or mitred upon the surface before installation.

Decorated by any of these processes, Tapestry Glass is particularly suitable for exterior doors, windows, ceiling lights or other openings. For office partitions, connecting doors, bank screens and other interior uses, plain Tapestry Glass is widely used, its even, brilliant surface giving an interesting and decorative effect.

Tapestry Glass is now installed in many new and beautiful churches, schools, office and business buildings, residences and apartments throughout the country. Investigate its possibilities through the nearest glass dealer or write for catalog and samples to the Pittsburgh Plate Glass Company.

**PITTSBURGH PLATE GLASS CO.**  
 GLASS                      VARNISH                      PAINT

# Murphy's Blue Print Manual for the Asking

Send  
for it  
Today!

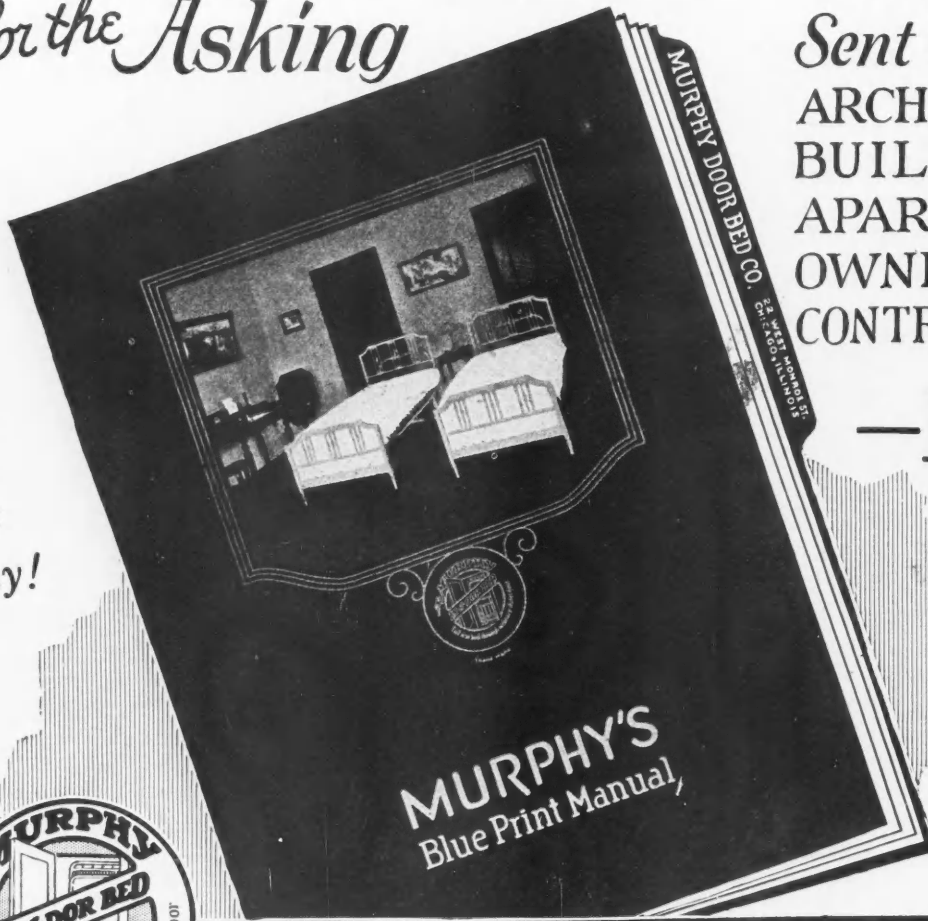

Sent to ~  
ARCHITECTS  
BUILDERS  
APARTMENT  
OWNERS and  
CONTRACTORS

—FREE

NOW  
READY  
for  
Distribution



## You'll Find the New Manual a Very Valuable Guide

The new Murphy Blue-Print Manual will prove one of the most interesting and valuable books ever published for the Building Trades of this country. It represents Apartment, Hotel and Home ideas gathered from every part of the country. Over a year of time has been devoted to its preparation. In it you will find the latest developments in the use of concealed beds and also complete blue-print details of every type of Murphy In-A-Dor installation.

Don't Fail to Order  
Your Copy at Once  
—TODAY!

## For Every Type of Concealed Bed Requirement SPECIFY MURPHY IN-A-DOR Beds

**N**EVER a question of doubt enters the minds of Architects, Builders, and Owners who have once used Murphy In-A-Dor Beds as to the value of their investment. They know from experience that it pays to always specify Murphy—(First)—because the Murphy In-A-Dor bed is by far the easiest of all concealed beds to install. (Second)—That the Murphy method of installation is the only one that allows a full size comfortable bed to be completely concealed behind an ordinary 3' wide door—(the door being free from all weight), thereby giving full access to bed closet whether bed is in use or not. And (Third)—Because there is a Murphy In-A-Dor type of concealed bed to fit every possible requirement. Let the experience of thousands of others be your guide and SPECIFY MURPHY BEDS every time.

There's Only One In-A-Dor Bed  
—THE MURPHY

## MURPHY DOOR BED COMPANY

Offices and Display Rooms in All Principal Cities:

22 W. Monroe St., Chicago. 1534 Blake St., Denver.  
Crocker Bldg., San Francisco. 1140-42 Hanna Bldg.,  
Cleveland. 204 Peach Tree Arc., Atlanta, Ga. 315 N.  
Tenth St., St. Louis. 1410 Kresge Bldg., Detroit, Mich.  
Terminal Sales Bldg., Seattle. 1114 Grand Ave.,

Kansas City. 469 Fifth Ave., New York City. 1919 Paci-  
fic Ave., Dallas, Tex. 309 Third Ave. N. Nashville.  
1807 S. Main St., Los Angeles. Neff-Stiles Bldg., El  
Paso. 319 Dryades St., New Orleans. 10 St. Antoine  
St., Montreal, Can. 205 O'Connor St. Ottawa, Can.

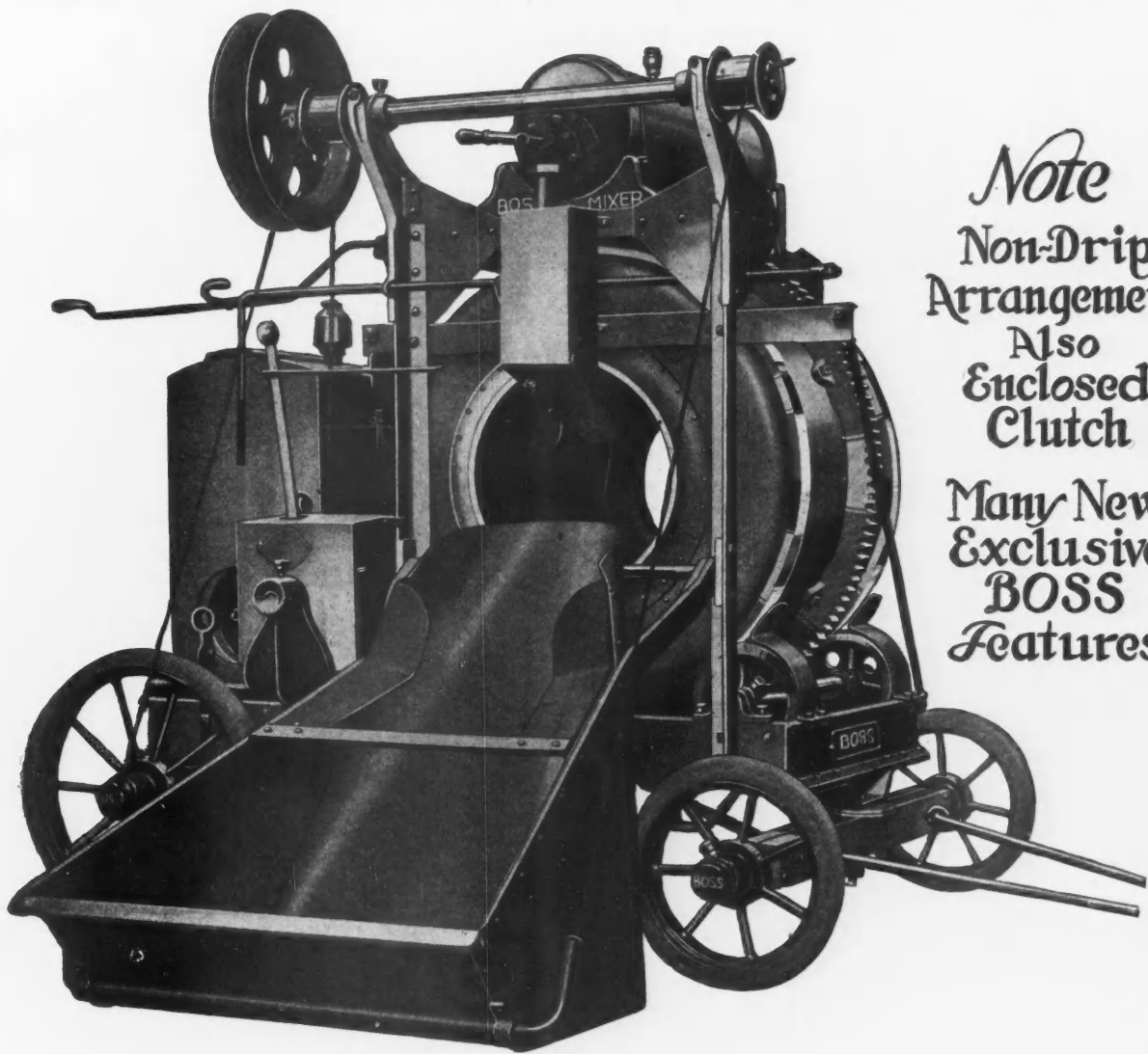

*Note*  
**Non-Drip  
 Arrangement  
 Also  
 Enclosed  
 Clutch**  
**Many New  
 Exclusive  
 BOSS  
 Features**

**A BIG ONE-BAGGER That's BUILT of STEEL**  
*Of Course It's Much Stronger, Yet Also Lighter*

Furnished in All Capacities

5S, 7S, 10S, 14S, 21S and 28S  
 Gas, Steam or Electric  
 Also in Low Charging Types

*OK'd*

**BY OVER 10,000 USERS**

**Reasonably Priced**

New Price List and Complete Catalog  
 Just Off the Press

—WRITE TODAY—

MANUFACTURERS

**The American Cement Machine Co., Inc.**

**Keokuk Iowa**  
THE 300,000 H.P. ELECTRIC CITY

Branch Offices—Warehouses

Chicago	Dallas	Louisville	Salt Lake City
Los Angeles	Buffalo	Knoxville	Atlanta
Seattle	Montreal	Tulsa	Indianapolis
Kansas City	Pittsburgh	New York	New Orleans
Minneapolis	Milwaukee	Detroit	Cambridge, Mass.
San Francisco	St. Louis	Philadelphia	Washington, D. C.

**Extremely Fast  
 Discharger**

Patented action discharges and remixes  
 with fewer drum revolutions. Discharge  
 control works from either side

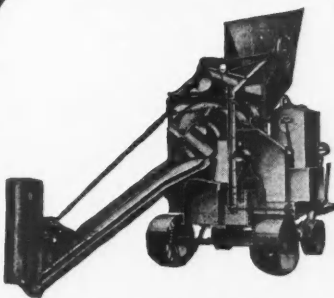

**Boss Alley-Street Paver**

**7E HANDY SIZE  
 TRACTION**

A Fast, Sturdy, One-Man  
 Paving or Building Mixer

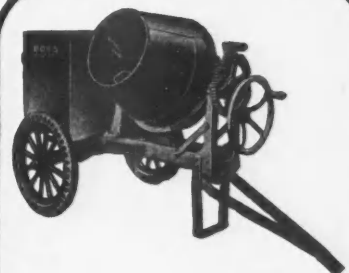

**Boss "Heavy Duty" Tilters**

**3 1/2S, 5S, 7S SIZES**  
 Low Chargers  
 Power Loaders  
 Auto Trailers

**POPULAR PRICES**

**BOSS HOISTS \$135 UP ALL SIZES**

# Allith-Prouty

"THE SIGN



OF QUALITY"

## Announcing the A-P "Five-Fifteen" Hanger with "Five-Fifteen" Track

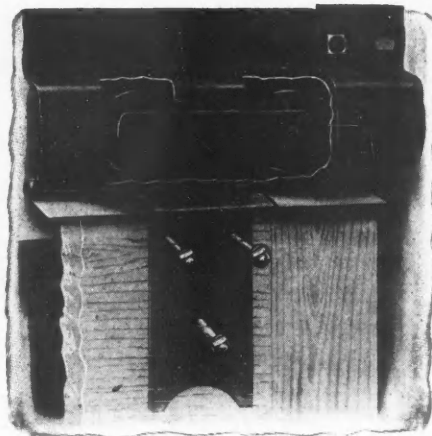

The new low-priced full watershed equipment for  
single and parallel sliding doors

**T**HE HANGER is of steel construction with roller-bearing machine-turned cast wheels. Has vertical adjustment and requires no lateral adjustment, for the hanger is applied to the wall side of the door.

The track is formed of one piece of steel into a design of remarkable strength and

efficiency. Bird and weather proof. No rivets or welds. No parts to assemble. Quickly erected with lag screws and nails packed with the hangers.

There's nothing to compare with "Five-Fifteen" at anywhere near the price. Let us send you full details.

### ALLITH-PROUTY COMPANY DANVILLE, ILLINOIS

Manufacturers of: Door Hangers, Garage Door Hardware, Fire Door Hardware, Overhead Carriers, Rolling Ladders, Spring Hinges

Representative Jobbers Distribute A-P Products Throughout the United States

## THE RIGHT HANGER FOR EVERY DOOR



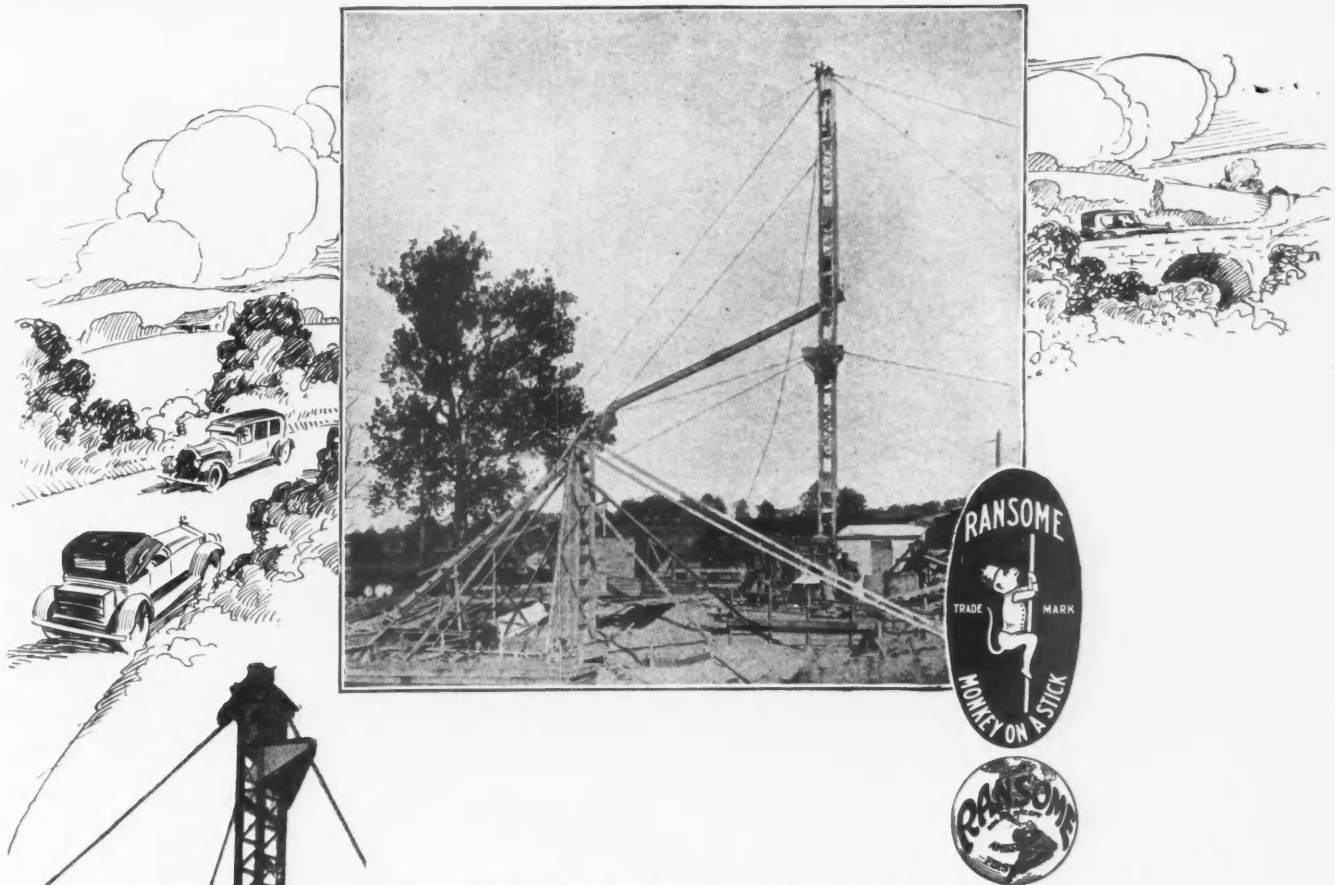

## Out on the Long Island Motor Parkway

Wallace M. Hendrick placed a batch of concrete almost every minute of the day with a Ransome Monkey-on-a-Stick outfit at the Rocky Hill Road Viaduct extension on the Long Island Motor Parkway.

For jobs of that kind or where a comparatively small amount of concrete is to be distributed over a relatively large area—as in “block type” residences, etc.—the Ransome Monkey-on-a-Stick is a world beater for economy.

If you have any work of this sort in prospect you should look up the Monkey-on-a-Stick. Send for Bulletin 115.

### RANSOME CONCRETE MACHINERY CO.

1764 Second Street, Dunellen, N. J.

Manufacturers of Mixers, Pavers, Pneumatic Mixers  
Chuting Plants, Hoist Buckets, Bins, Cars, Carts, etc.

*Ransome*



**THE PIONEER**

First concrete mixer—1850.  
First in the field of Concrete Machinery ever since.

Without obligation on my part, please send me information on;  
Ransome Concrete Mixers, sizes, 4-S [ ]: 7-S [ ]: 10-S [ ]: larger sizes [ ]: Steam Drive [ ]: Gasoline Drive [ ]: Electric Drive [ ]: Concrete Chuting Plant for Building.....ft. long by.....ft. wide by.....ft. high: Portable Woodworking Mill [ ]  
Name..... Address.....

7632

Henry Raeder  
Architect  
George C. Nimmons & Co.  
Associates



Wells-Brothers Construction Co.  
General Contractors  
Lieberman & Hein  
Civil Engineers  
Central Lime and Cement Co.  
Supplied Ohio White Finishing Lime.

The Furniture Mart  
Chicago

## The Colossus of Modern Building

THE Furniture Mart in Chicago, proclaimed by statisticians as the world's largest building under one roof and constructed entirely at one time, adds another triumph to the skill and ability of architect, engineer and contractor.

Among other justly famous materials used in the construction of this Colossus of modern architecture was OHIO WHITE Finishing Lime. In fact 842 tons of this lime were used to make the interior walls of this building permanent and beautiful.

The purity and natural composition of OHIO WHITE unite to produce a hard, snow-white wall, acoustics-improving, metal preserving, fire-resisting and free from chipping, checking and blistering.

Write for booklet. "A Job That Took a Million Years". It contains full details and explains why Ohio White gives such unusual satisfaction wherever used in construction.



Ask the Plasterer  
—He Knows!

### The Ohio Hydrate & Supply Co.

Woodville, Ohio

"The Lime Center of the World"



Will the Owner  
**PAINT** this  
 house or will  
 he "OVERCOAT"  
 it?

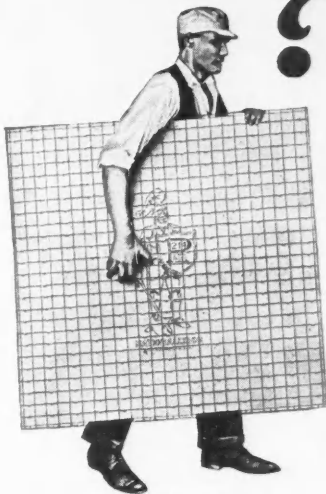

Look for the "Sir Fabric" trademark on every sheet—it is your guarantee of quality and of service.



If he *paints* it, there's no work for architect, contractor, plasterer, lather, or for us. And the owner is simply piling up his cost of "up-keep."

If he "*overcoats*" it, there is work for all of us—and the owner is through with "upkeep"—permanently.

If you are interested in this new and tremendous market for your service, write for our Special Bulletin entitled "New Homes from Old Houses."

**NATIONAL STEEL FABRIC COMPANY**

(SUBSIDIARY OF PITTSBURGH STEEL CO.)  
 706 Union Trust Building, Pittsburgh, Pa.

OFFICES: Atlanta Cincinnati Chicago Cleveland Dallas Denver  
 Detroit Houston Los Angeles New York City Philadelphia  
 Pittsburgh Rochester St. Louis San Antonio San Francisco  
 STOCKS: Chicago Houston Los Angeles New York Pittsburgh  
 San Francisco



About 83 out of every 100 houses are *frame* (based upon U. S. Department of Commerce figures covering the East North Central States)—in other words, more than 17 million of America's 20 (odd) million homes need painting every two years. And painting, in forty years, amounts to probably more than the original cost of a frame house.

**NATIONAL STEEL FABRIC CO**  
 Subsidiary of PITTSBURGH STEEL Co  
 UNION TRUST BUILDING PITTSBURGH, U.S.A

# \$10,000 in one month

*—that's what Johns-Manville  
Asbestos Shingles rang up  
on Mr. Carter's cash register*

AND his business is increasing all the time. He is Mr. W. M. Carter, of Laurel, Miss. He started by buying Johns-Manville Asbestos Shingles for his own home. His friends and neighbors became so enthusiastic that he soon began to see possibilities for the sale of these Shingles. As our distributor his business mounted steadily upward. Now he is devoting his entire time to roofing. One month his contracts ran well over \$10,000. This is what he says: "I have often been complimented as a good salesman but I feel it is not so much the salesman as the product which is responsible for success. Prospects are splendid for a constant roofing business for an indefinite period ahead. Hereafter, I am going to sell only Johns-Manville Asbestos Roofing for all roof conditions."

Take the cue from Carter. Whether you are in a small city or a large one, your opportunity is just as great. Right in your own town someone will ring up roofing profits on his cash register. Write us about it and let us help you get this business.

JOHNS-MANVILLE Inc., 292 Madison Ave. at 41st St., New York City

Branches in 62 Large Cities

For Canada: CANADIAN JOHNS-MANVILLE CO., Ltd., Toronto

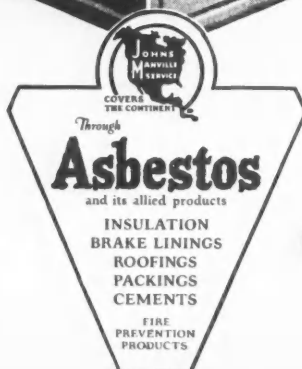
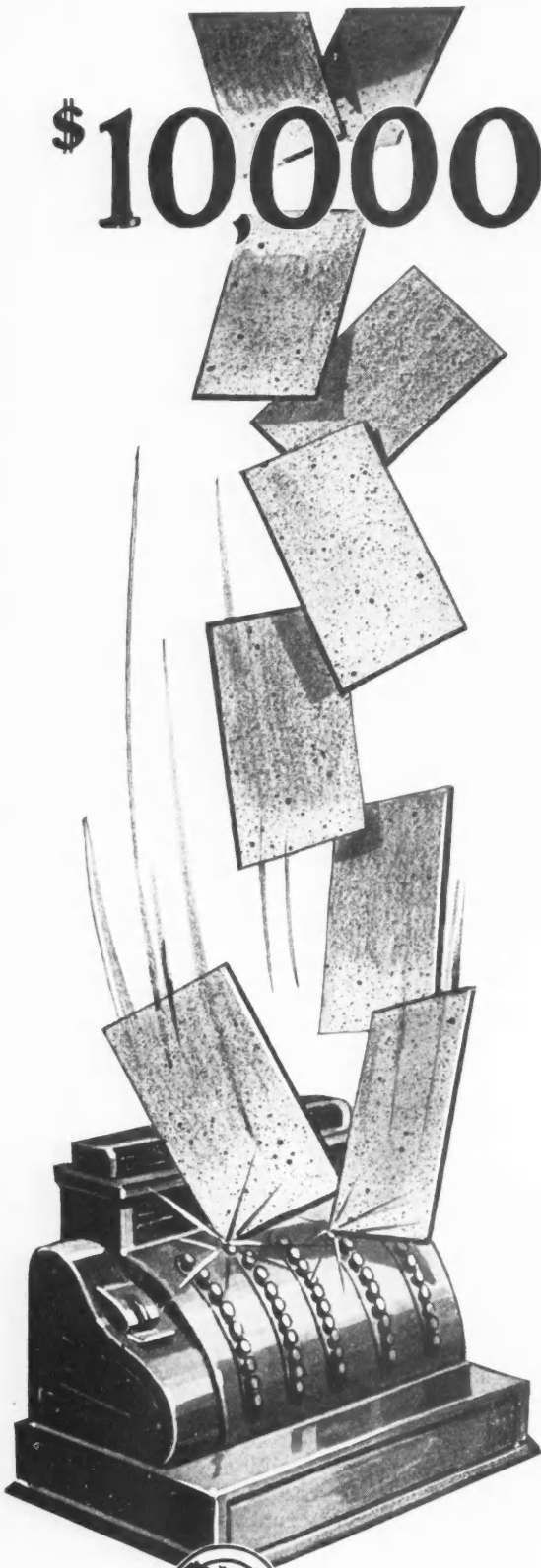

# JOHNS-MANVILLE Asbestos Shingles





Kernerator equipped duplex, Milwaukee.  
Thomas Van Alyea, Architect.

## A Convenience the Better Home Deserves

JUST as good plumbing has replaced the pump, the pail and the open drain—just as modern heating has made the fireplace an item of sentiment and decoration—just as electricity lights the home of today and takes over most of the chores—

*So, through the time-tried Kernerator, instant garbage and waste disposal is becoming, more and more, "standard practice."*

Architects, builders and realtors everywhere, recognize in the Kernerator a sound principle, soundly applied. And their judgment is borne out by the thousands of Kernerator installations for years in constant satisfactory operation.

### **Costs Nothing to Operate—No Fuel Required**

The Kernerator, as illustrated, consists of a brick combustion chamber at the base of the chimney, with handy hopper doors on the floors above. All waste—garbage, sweepings, tin cans, glass, shavings, papers and magazines, crockery, and rubbish of every type—is simply dropped through the hopper doors. An occasional lighting is all that is necessary. Everything combustible is quickly reduced to ashes, while non-combustibles are flame-sterilized and removed with the dry ashes.

KERNER INCINERATOR CO., 1053 Chestnut St., Milwaukee, Wis.

# KERNERATOR

Built-in-the-Chimney

Reg. U. S. Patent Office

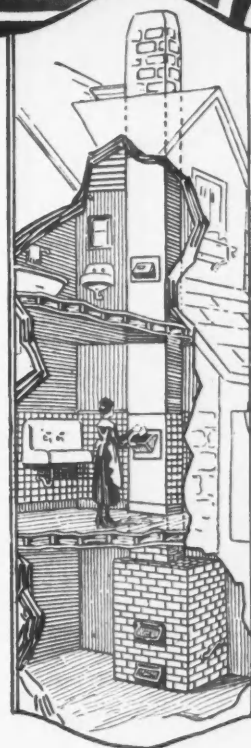

Convenient detailed information appears in Sweet's (1924) pages 2536-37. We will be very glad to furnish any further data you may desire and to refer you to our nearest special representative.



# Steel Sheets and Tin Plates

Made from Keystone Rust-resisting Copper Steel



The destructive enemy of sheet metal is *rust*. An alloy of Copper gives to Steel Sheets and Tin Plates the highest degree of resistance to rust and corrosion. This is a fact, proved by actual time and weather. Keystone Copper Steel gives superior service and satisfaction for roofing, siding, spouting, gutters, culverts, tanks, metal lath—and for all uses in the contracting and building construction field.

We are manufacturers of Sheet and Tin Mill products for all purposes—Black Sheets, Apollo and Apollo-Keystone Galvanized Sheets, Corrugated Sheets, Formed Roofing and Siding Products, Sheets for special purposes, Roofing Tin Plates, Bright Tin Plate, Black Plate, Etc. Sold by leading metal merchants.

Remember, when resistance to rust is a factor, it is important that you demand Keystone quality. Its greatest testimonial is its users:

Important railroads use Keystone for roofing and new car construction.

The U. S. Reclamation Service, the U. S. Forestry Service, and Bureau of Public Roads use Keystone for the construction of culverts, flumes and tanks.

Prominent septic tank and vault makers use Keystone for greater durability.

Successful architects, engineers, contractors, roofers and builders use Keystone for maximum wear and rust-resistance.

Leading burial vault and casket manufacturers use Keystone for increased permanence and protection underground, where both service and sentiment demand enduring quality.

Keystone Copper Steel demonstrated its excellence in the service tests of the American Society for Testing Materials. Could you ask for more thorough and impartial proof?

Users everywhere favor Keystone for all purposes requiring lasting service. Send for "Facts" booklet.

## American Sheet and Tin Plate Company

General Offices: Frick Building, Pittsburgh, Pa.

DISTRICT SALES OFFICES:

Chicago Cincinnati Denver Detroit New Orleans New York Philadelphia Pittsburgh St. Louis  
Export Representatives: UNITED STATES STEEL PRODUCTS COMPANY, New York City  
Pacific Coast Representatives: UNITED STATES STEEL PRODUCTS COMPANY, San Francisco, Los Angeles, Portland, Seattle

# Level and Plumb Better and Quicker Own Your Own—Make More Money

**\$5.00**  
Brings  
it to you

This instrument will add immeasurably to your efficiency and put you in the big builder class—will do more to increase your business, income and prestige than any investment you ever made. The Aloe Convertible Level is the world's best—a combination of both level and transit and quickly converted to either. Very accurate—satisfies the most exacting—yet so simple that anyone can use it.

**FREE  
TRIAL**

## Aloe Convertible Level And Transit—Combined

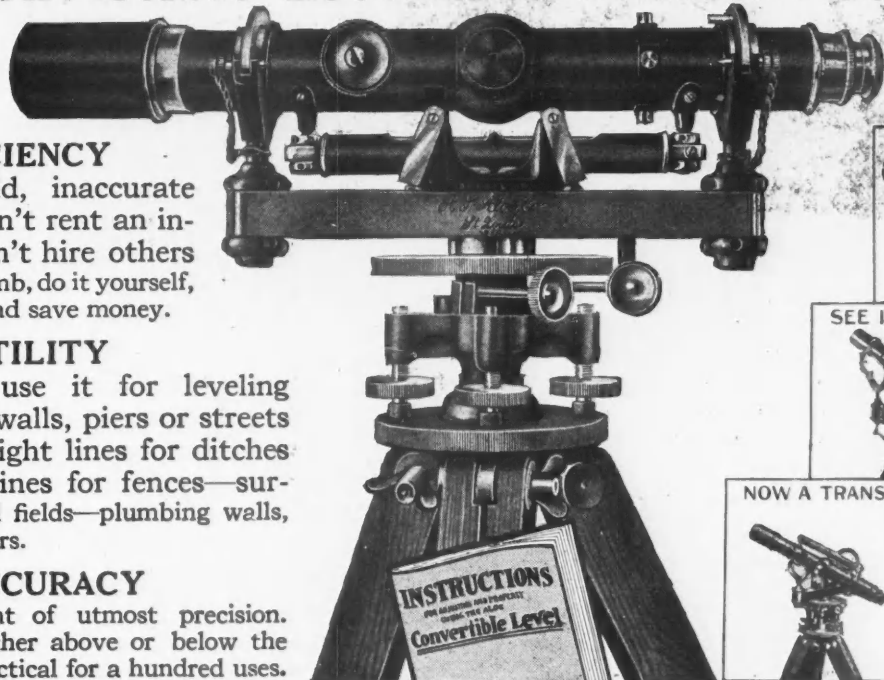

### EFFICIENCY

Discard old, inaccurate methods. Don't rent an instrument; don't hire others to level and plumb, do it yourself, faster, better, and save money.

### UTILITY

You can use it for leveling foundations, walls, piers or streets—to run straight lines for ditches—boundary lines for fences—surveying lots and fields—plumbing walls, shafts, and pillars.

### ACCURACY

An instrument of utmost precision. Takes sights either above or below the horizontal. Practical for a hundred uses.



## You Learn To Use It In An Hour!

No technical knowledge needed—no experience necessary. With our plain and complete instruction book, included free, you can put the instrument to use at once. It is simple in construction and operation. Will do more to bring you success than years of plodding.

### Free Trial—Easy Terms

Just \$5.00 brings it to you complete—on 10 days' trial. If perfectly satisfied pay the balance in easy monthly installments. Use it while you pay. It earns money faster than the easy monthly payments come due.

**FREE  
BOOKLET**



### GET THIS BOOK →

Be alert to this great opportunity! Don't let negligence rob you of this chance—it may be the turning point in your career. Fill in the Coupon, mail it NOW and get your Free copy of our booklet, "Be a Bigger Builder," that tells you how to increase your income and standing. Success comes to the energetic. In fairness to yourself—investigate.

**A. S. ALOE CO. 621 OLIVE STREET ST. LOUIS**

### MAIL COUPON FOR IT

A. S. ALOE CO., 621 Olive Street, St. Louis, Mo.

Without obligation, send me your FREE book, "Be a Bigger Builder." Also full particulars about the Aloe Convertible Level and details of your easy payment plan.

Name .....

Address .....



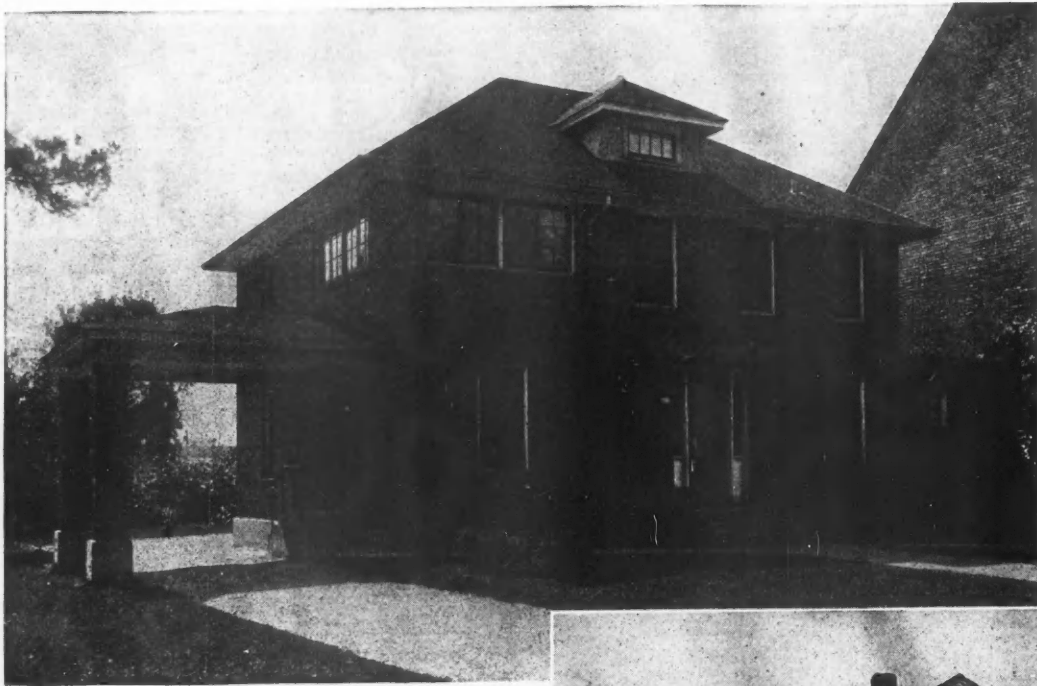

*HERE is another splendid example of what architects and contractors can do in rebuilding an old structure. Not only is the remodelled house more sightly, but in the future there will be no bills for painting and repairs. The pictures show the Rectory of St. Francis Church at Ottawa, Illinois, before and after the brick veneering job was done. H. B. Dox of Peoria was the architect and Simnot Bros., of Ottawa, the contractors.*

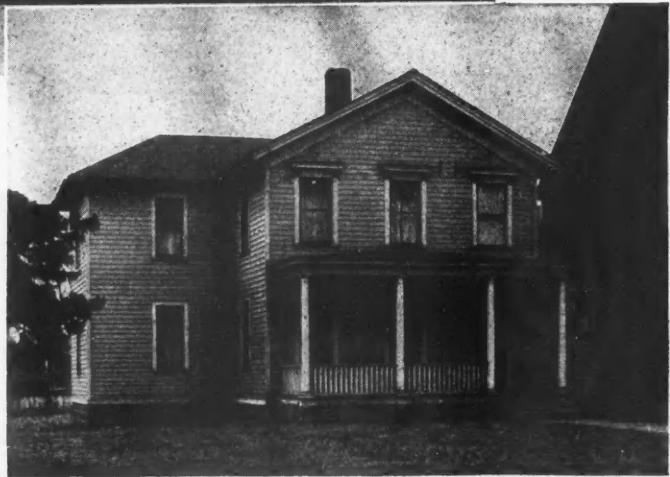

## “A New House for the Old”

**T**HIS is the title of a booklet which we have just issued on the veneering of old structures. It shows illustrations of a number of jobs as they appeared before and after a veneer of Face Brick was applied, and also gives complete directions as to how to veneer a building.

Contractors will not only be interested in this book but will find in it suggestions that will help them increase their business. In every community there are numerous old

frame and stucco buildings which can be made beautiful and up-to-date with an overcoating of Face Brick. And, at the same time, future outlay for painting and repairs will be eliminated. The field for this work is large and only awaits the initiative of the enterprising contractor.

Send today for your free copy of “A New House for the Old,” and look into the possibilities for veneering jobs in your locality.

### THE AMERICAN FACE BRICK ASSOCIATION

1763 Peoples Life Building • Chicago, Illinois





# It's Dependable

## Famous Junior "30" Woodworker



THE amount of work you can do on Jr. "30" woodworker and the economy of doing it will surprise you. Every woodworking operation from cutting rough lumber to finishing the finest trim can be performed upon the Jr. "30".

And then the remarkable low cost of this machine and its installation and maintenance are many times lower than that of the five machines it includes. Only one installation, only one motor to require power and only 48 square feet of floor space are necessary when you have the Famous Jr. "30". In fact no other woodworker made offers the advantages of this machine and no other woodworker has as many exclusive features and attachments.

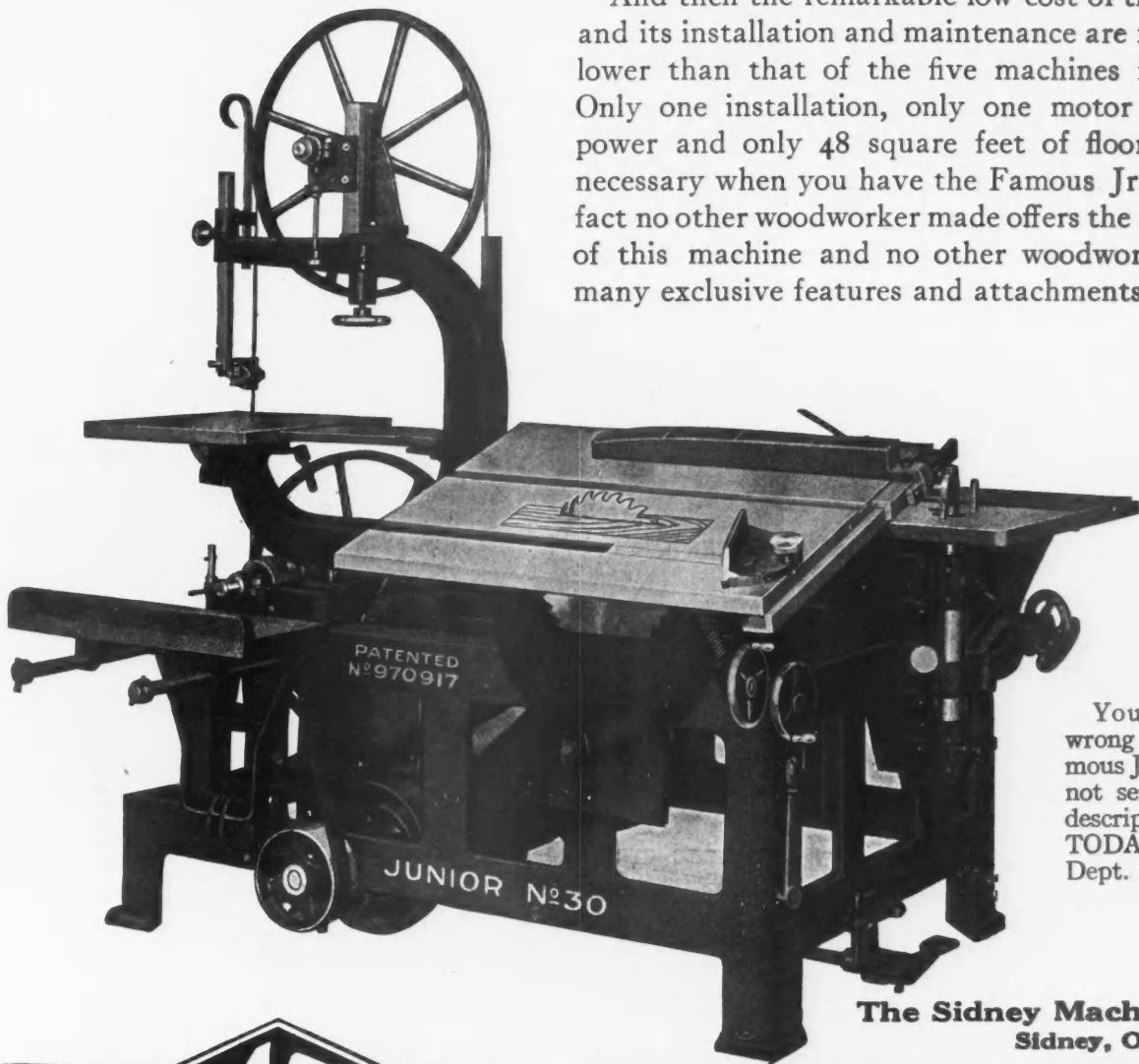

You can't go wrong with a Famous Jr. "30". Why not send for fully descriptive booklet TODAY? Address Dept. 103.

The Sidney Machine Tool Co.  
Sidney, Ohio

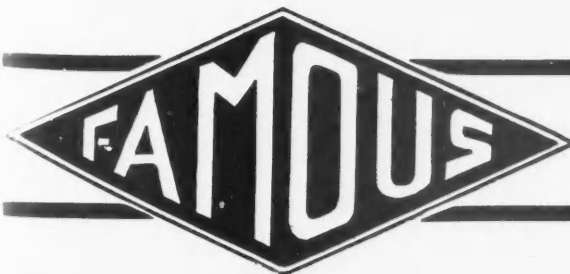

# Woodworkers

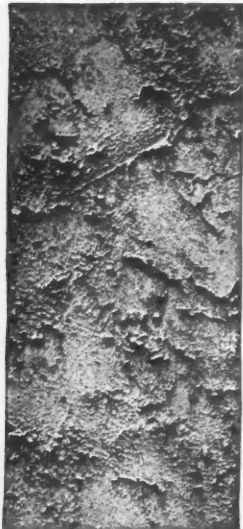

ENGLISH COTTAGE



ITALIAN

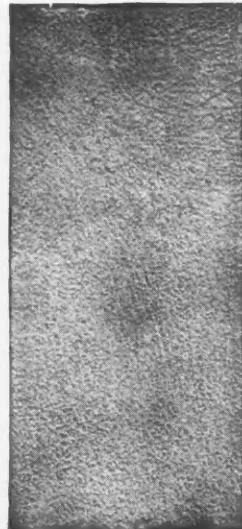

COLONIAL

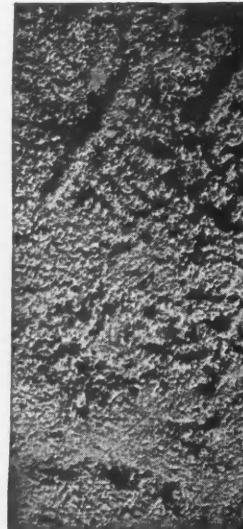

GOTHIC



ITALIAN COTTAGE

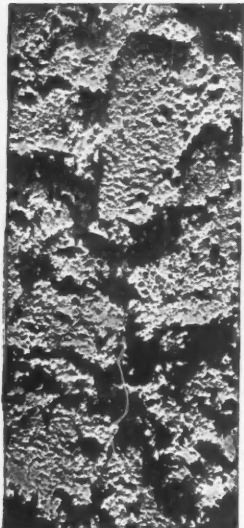

GREEK

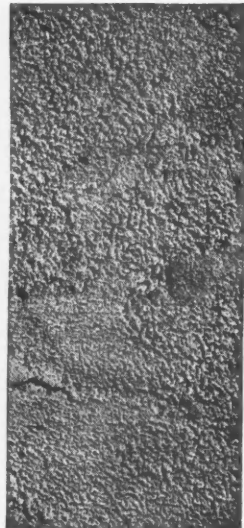

MODERN AMERICAN



ENGLISH



FRENCH



CALIFORNIA

*The Portland Cement Stucco textures here shown are taken from photographs of actual stucco jobs. Any competent workman in the plastering trade can reproduce these beautiful, permanent and economical finishes.*

## A Texture for Each Period

Controlled and directed by the creative genius of the architect, Portland Cement Stucco assures a range of beauty obtainable with no other material. It makes certain a texture and tint that complete harmoniously the style of the period in which the structure is designed. Have you received your copies of "Portland Cement Stucco Textures" and "Portland Cement Stucco"? If not, send for them today. Address the nearest office listed below.

### PORTLAND CEMENT ASSOCIATION

*A National Organization to Improve and Extend the Uses of Concrete*

ATLANTA	BOSTON	DALLAS	INDIANAPOLIS	MEMPHIS	NEW YORK	PITTSBURGH		
BIRMINGHAM	CHARLOTTE, N. C.	DENVER	JACKSONVILLE	MILWAUKEE	OKLAHOMA CITY	PORTLAND, OREG.	SEATTLE	
	CHICAGO	DES MOINES	KANSAS CITY	MINNEAPOLIS	PARKERSBURG	SALT LAKE CITY	ST. LOUIS	WASHINGTON, D. C.
		DETROIT	LOS ANGELES	NEW ORLEANS	PHILADELPHIA	SAN FRANCISCO	VANCOUVER, B. C.	

*Our Booklets are sent free in the United States, Canada and Cuba only*

# 20,000 Gallons Per Hour 24 Hours a Day

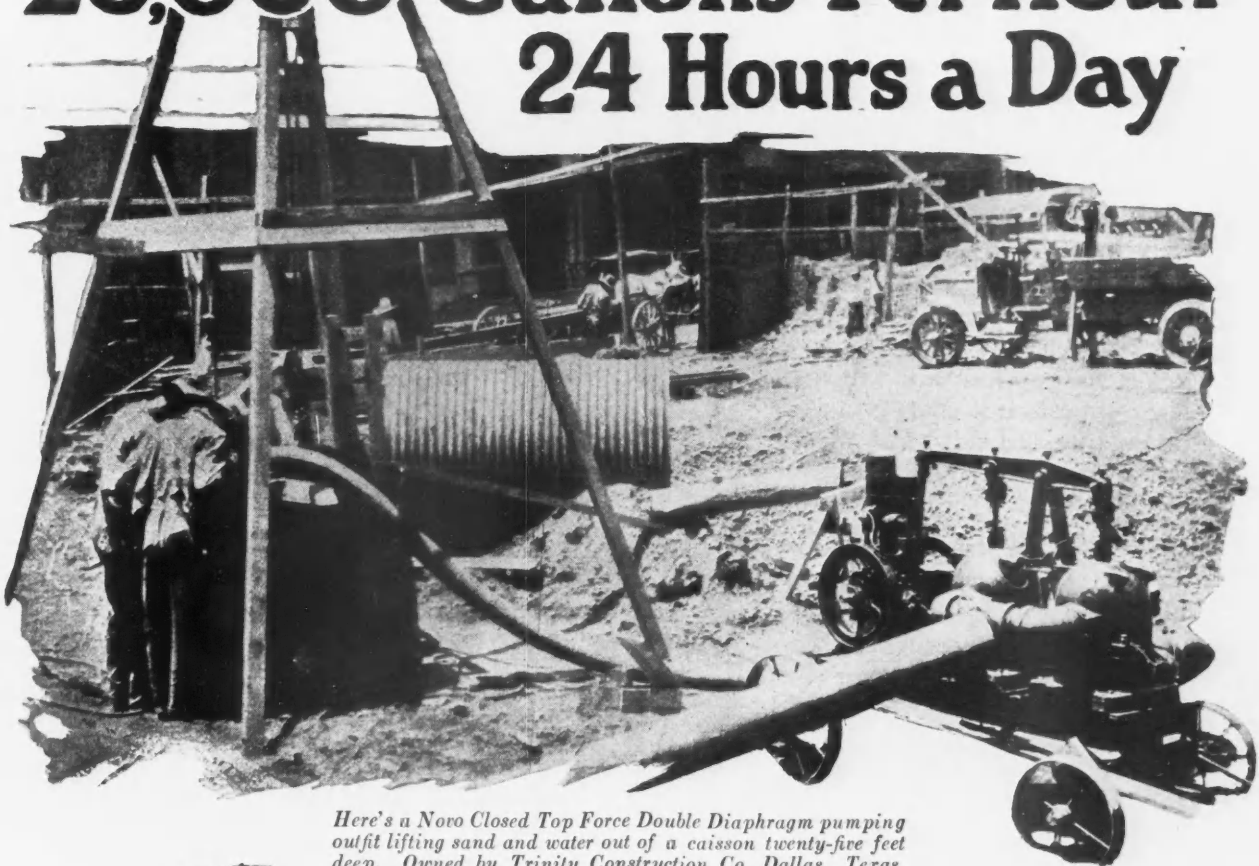

Here's a Novo Closed Top Force Double Diaphragm pumping outfit lifting sand and water out of a caisson twenty-five feet deep. Owned by Trinity Construction Co. Dallas, Texas.



Novo Open Top Single Diaphragm Pump



**N**OVO Double Diaphragm Pumping Units (open and closed) will furnish up to 20,000 gallons per hour, twenty-four hours a day. Capacity is a big thing in a diaphragm pump, but the ability to stick to a job day in and day out is a bigger one. To handle water in your excavation, a pump must work with complete disregard for time. The reliable Novo Engines with which Novo Pumps are equipped are made for just such service. Twenty-four hours a day is a part of their job. Novo Closed Top Force Diaphragm Pumps (both single and double diaphragm) are made for heads up to 50 feet.

You will be interested in the complete line of Novo equipment for construction purposes. Literature gladly mailed on request.

**NOVO ENGINE CO.**  
Clarence E. Bement, Vice-Pres. & Gen. Mgr.  
LANSING, MICHIGAN  
Cable Address: "NOVO LANSING"  
Distributors Throughout the World

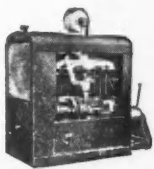

## NOVO POWER

Keeps Operations Moving



**ENGINES**  
Single Cylinder, 1 1/2-10 H.P. (frost proof)—two cylinder, 6-12 H.P.—four cylinder, 12-40 H.P.

**HOISTS**  
Single and double drum—one and two speed and reversible, portable heavy duty types—powered with Novo Engines



**PUMPS**  
Open and closed top diaphragm—centrifugal—deep well—single, duplex double acting and triplex pressure pumps.

**COMPRESSORS**  
Three sizes—up to 170 cubic feet—with steel housings mounted on trucks. Combination hoists and compressors



## Economy Now —But Later?

1

So often the temptation to "use a little cheaper lumber" is alluring.

Many times a man will consent to cheapen his construction—but never would he be willing to cheapen its first appearance!

Yet *first* appearance will not last—investment value will not be maintained—if that most important factor, *construction*, is slighted.

2

Whether a family buys a new home, or builds one, the importance of construction dependability should not be overlooked.

Short cuts of economy to home ownership, by means of buying poor lumber, are never satisfactory in the end.

Reputable builders today are insisting more and more on dependable construction—because that is the one way to satisfactory home ownership.

3

The dependability of Long-Bell trade-marked products fits them for use in good construction. They give continued satisfaction during the life of a home—in the end they are less costly—and, most important, they aid in giving a man that pride which comes in ownership of a home *built for the years!*



Users of lumber for home-building should seek the sort of economy that will seem wisest after a few years have passed—economy *plus investment value*. It is this sort of long-time dependability that Long-Bell trade-marked lumber gives to construction.

The Long-Bell Lumber Company  
R. A. Long Building Kansas City, Mo.  
*Lumbermen Since 1875*

# LONG-BELL

Trade Marked L U M B E R

Douglas Fir Lumber and Timbers; Southern Pine Lumber and Timbers;  
Creosoted Lumber, Timbers, Posts, Poles, Ties, Guard-Rail  
Posts, Piling; Southern Hardwood Lumber and  
Timbers; Oak Flooring; California White  
Pine Lumber; Sash and Doors.





*Residence of Dr. John M. Dean, St. Louis, Mo., in which a McCray refrigerator will protect the family's health by keeping food fresh, pure and wholesome.*

## When Building to Sell or For Your Own Home

Wise builders install McCray refrigerators in their own homes and in houses built to sell. In their own homes the McCray protects health, saves food and money. And the *known value* of the McCray is an added asset when you come to sell.

McCray standard stock models meet all usual requirements in homes, institutions, stores and markets. When specially built equipment is necessary or advisable, McCray engineers submit blue prints, based on your rough sketches, without obligation.

Built-to-order equipment by McCray embodies the skill and craftsmanship developed in our third-of-a-century experience; highest grade materials, each proved best for its particular purpose; and scientific design insuring active air circulation.

We build refrigerators for every purpose—for homes, hotels, restaurants, clubs, hospitals, institutions, stores, markets, florist shops. Send for the latest McCray catalogs for your files.

*All McCray models are easily adapted for use with any type of mechanical refrigeration.*

### McCray Refrigerator Co.

2560 Lake St., Kendallville, Ind.

Salesrooms in All Principal Cities. See Telephone Directory

**MCCRAY**  
REFRIGERATORS  
*— for all purposes —*

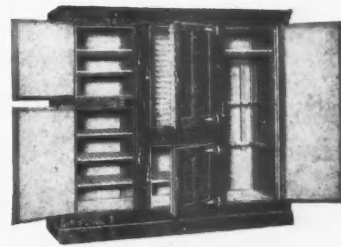

McCray No. 1155

A Popular Model for Institutions.

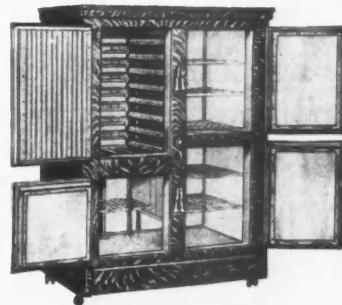

McCray No. 460

For Residences.

### Look for the McCray Name Plate

You'll find it on the refrigerator equipment in the better stores, markets, hotels, hospitals, restaurants, florist shops and in homes. This name plate gives positive assurance of foods kept pure, fresh and wholesome.

# Building Good Will with Holland Furnaces

**I**F HOME buyers find the heating system entirely inadequate for their new home they naturally fix the responsibility on the man who sold it to them.

They know the seller has installed a cheap furnace, totally unfit for the requirements to make a really comfortable and happy home.

Naturally these people will "knock" the seller.

No matter how carefully other elements of the house have been looked after, it is impossible for a family to keep happy, healthy and contented in a "Cheap Furnace House."

If home buyers find the healthful warmth that a Holland Heating System always provides, no builder can have a better advertisement. They tell everyone how comfortable they are—how well they like the home. The word will be passed along how well and carefully "So-and-So" builds.

Holland Furnaces will help you enjoy such a reputation.

Just write or phone the Holland Branch in your city. The Holland Furnace Company will assume complete responsibility; all details are taken off your hands, and you are fully protected by the Holland Service Bond—Five-Year Home Comfort Insurance.

## THE HOLLAND FURNACE CO.

General Offices: Holland, Michigan

Two Factories:

Holland, Michigan; and Cedar Rapids, Iowa

Central Office, Chicago:

Straus Building, Michigan Ave.  
and Jackson Blvd.



*The Sign of Dependable  
Heating Service in more  
than 300 Cities.*

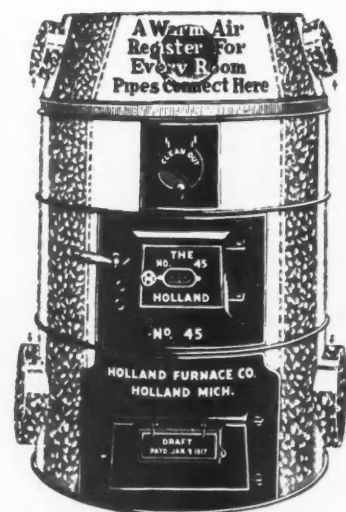

*The Holland is NOT a pipeless furnace. It is a complete pipe system with cold air returns from rooms above the basement.*

*The World's Largest Installers of Furnaces*

# Holland Furnaces Make Warm Friends

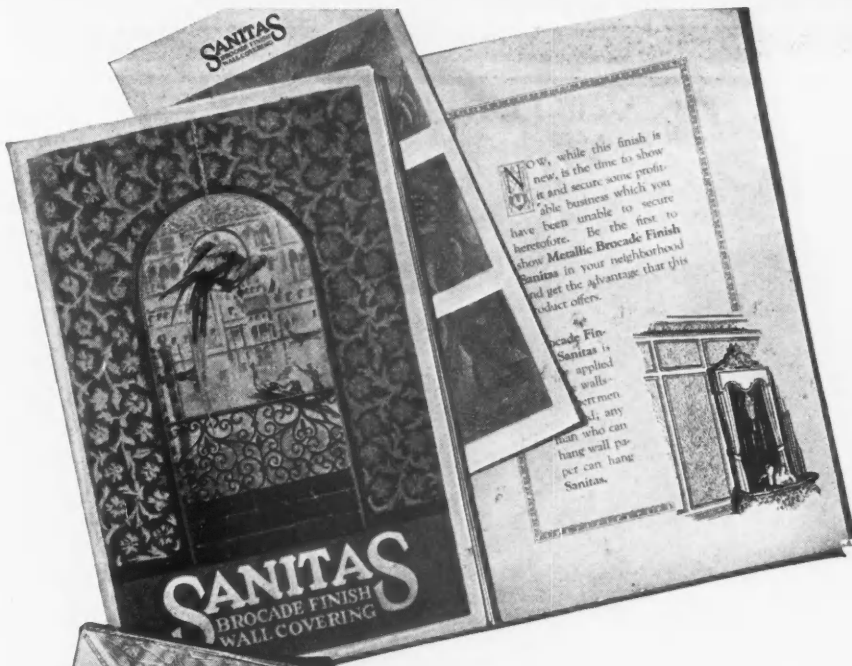

# SANITAS

MODERN WALL COVERING

*Cut down the repair bills*

Homes with Sanitas covered walls are worth more. They make a better impression on prospective purchasers, who know that Sanitased walls are stronger and stay in better condition longer, with less upkeep expense, than where any other wall covering is used.

Most home buyers think long on the subject of depreciation. Let them know that repairs for cracked walls and the replacement of torn, peeled, blistered and faded wall decorations are eliminated by Sanitas, and you have lessened their fear of the upkeep burden.

Sanitas is made on cloth, ready-painted with durable oil colors that can be kept clean with a damp cloth. It does not crack, tear, peel, blister or fade, and can be hung on any flat surface. On old walls just fill the cracks and hang the Sanitas; put it on new walls as soon as the plaster is dry (no need to wait for settling); Sanitas for the modern plasterboards is ideal.

*Styles for every room in the house*

**Plain and Pastel Flat Finish**

tints that can be hung as they come, or stenciled, frescoed, or Tiffany blended.

**Decorative Flat Finish**

conventional and foliage patterns, stripes, mottles, and tapestry, grass-cloth, leather and fabric effects.

**Brocade and Metallic Finishes**

in embossed effects for paneled treatments and trimmings.

**Enamel Finish**

plain colors, tile effects and decorative patterns, for kitchens, bathrooms, etc.

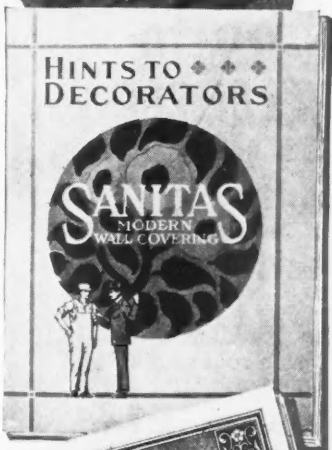
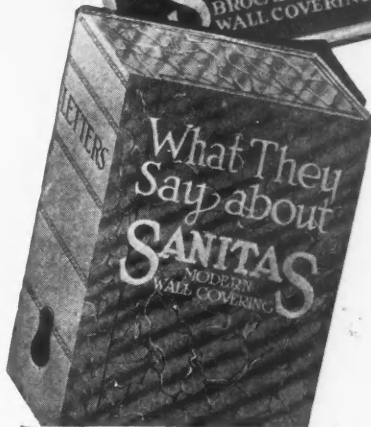

**THE STANDARD TEXTILE PRODUCTS CO.**

**320 BROADWAY, NEW YORK**

DEPT. K

Pacific Coast Office:

810 Santa Fe Ave. Los Angeles, Cal.

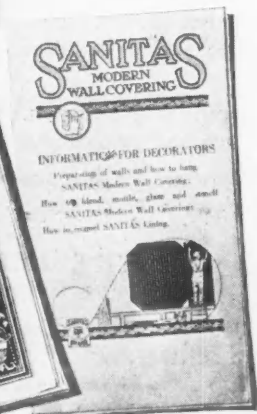

*Upon request our Architects' Service Bureau can furnish valuable information and data drawn from a wide experience. Also ask for any of the literature shown on this page. It will tell you just what you want to know, quickly.*

**"NOT A KICK IN A MILLION FEET"**

*Reg. U. S. Pat. Off.*



## Builders get from \$100 to \$200 more for dwellings roofed with Mule-Hide Rainbow shingles

The soft, beautiful tapestry color effect, which for many years has been sought by Architects and Builders in Asphalt Shingle Roofs is now produced in the MULE-HIDE Rainbow Shingle.

The MULE-HIDE Rainbow Shingle is a blending of soft, contrasting, pleasing colors—marked by the absence of sharp or flashy contrast—producing a wealth of delightful color tones that intensify in beauty as they season and grow older.

Made in 3-unit, 4-unit and Extra Heavy Individual type Shingles.

Maximum profits and salability are assured when you roof with Mule-Hide Rainbow Shingles.

Builders get from \$100 to \$200 more for Rainbow roofed houses, resulting in net increased profit on each roof of \$90 to \$180, according to the size of the roof.

The Mule-Hide Rainbow Roof is a selling attraction. It puts a new note of cheerfulness and an atmosphere of character into the exterior of the house and is, therefore, a strong talking feature in making the sale.

This new beautiful shingle will pay you big dividends in satisfied customers, net increased profits and quicker turnover.

Write or wire at our expense for full size samples and literature and full color illustrations of the complete roof.

**THE LEHON COMPANY**  
Manufacturers,  
44th St. and Oakley Ave., Chicago







## Famous Garland Dependability Plus New Mechanical Features

The Garland Warm Air Furnace, famous because it excelled in all the fundamental qualities, has been greatly improved by the use of a new Triplex Double Action Grate and a new Ash Pit.

As you read about or examine these new features, please remember that they are simply additions to a furnace already noted for its economy and efficiency.

The Michigan Stove Company  
Detroit, Michigan



Three shaker bars insure much more thorough removal of ashes. Every part of the bed of coals is affected uniformly by the action of the shaker.

Ashes can not accumulate around the edges where they interfere with combustion, and necessitate the dumping of large quantities of half burned fuel.

Thus the Garland Triplex Grate insures the most efficient consumption of coal.

# GARLAND

## HEALTHFUL HOME HEATING

WHEN WRITING ADVERTISERS PLEASE MENTION THE AMERICAN BUILDER

# HESS *Welded Steel* FURNACE

Every Home Builder Should Have This Valuable Book on Home Heating -- Tells

Why square shape is superior to round.

How fire-brick lining assures complete fuel combustion; prevents burnt out furnaces.

How fire door arrangement simplifies tending fire.

How front draft gives quick results.

How separate grate bars keep clean fire.

Advantage of extra size ash pit door.

Why furnace with welded steel radiator never leaks and delivers all the heat, and is the only kind you should consider.

## SENT FREE

Modern Furnace Heating, containing all the facts on home heating systems, for the home owner, builder and contractor, will be sent FREE on request. Send for your copy. ASK ABOUT OUR FREE HEATING PLAN SERVICE; TIME PAYMENT PLAN, ETC.

How constant hot water supply is maintained.

Why rectangular fire box is necessary for highest heating efficiency.

How separate grate bars burn any fuel.

How special type ash pit lengthens life of furnace.

Why high cap is used.

How water evaporation makes healthful heat.

How automatic draft operates, preventing escape of smoke.

How special fire door saves fuel.

How air supply collar maintains warm air circulation.

## Besides all these facts MODERN FURNACE HEATING

contains an authoritative and exhaustive explanation and comparison of the heating principles involved in the use of steam, hot water, and hot air heating systems as well as stoves, and the results and relative merits of each.

You need this valuable home heating book.

When low cap is best.

Why emergency direct draft is essential.

How smoke outlet prevents clogging; saves fuel.

Why check draft placement gives perfect control.

How inner casing quickens results; prevents heat waste.

How indirect smoke outlet saves all the heat; saves waste up chimney.

How clogging flues are eliminated.

Why bottom air space gives equal heat distribution.

Why settling chamber is indispensable for heating efficiency.

We want live dealer and contractor agents in every town—write us.

HESS WARMING AND VENTILATING COMPANY

1220-H South Western Avenue - Chicago

Branch Offices: Brooklyn, N. Y.; Detroit; Cincinnati; Milwaukee; Minneapolis.

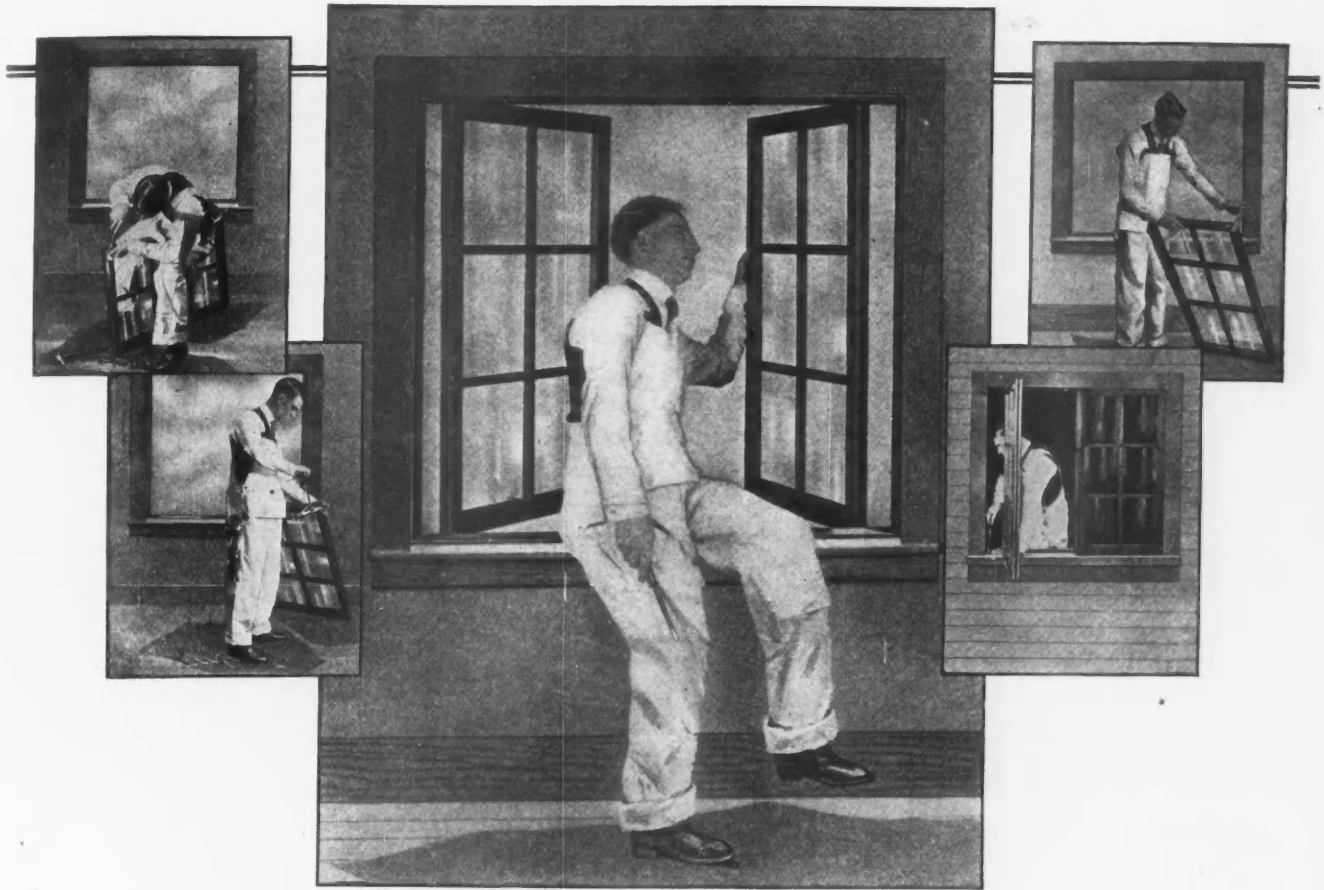

## WHITCO "The Easy Hardware"

The first time a carpenter installs a casement or transom with  
**WHITCO**

he may not be able to show much of a saving in time and labor as compared with the use of butts and adjusters—

But once he gets the few simple directions fixed in his mind—

As soon as he sees that this hardware not only swings the window as effectively as a pair of butts, but controls it better than any adjuster he ever put on—

After he gets over wondering why someone did not think of some such device before—

He will show a real saving on every installation thereafter, whether it is a single sash, a pair or sash or multiple sash in wide openings without mullions—or transoms.

As the smaller illustrations show, the job is a simple one.

After fitting the sash, he cuts a housing in the top and bottom of the sash; attaches the hardware; turns the sill plate at right angles to the sash; sets it in the opening and secures it to the head and sill.

Just about the same amount of work involved in the installation of one butt—

**A clear saving of the time and trouble required for installing the other hinge and the adjuster.**

You can buy WHITCO from your Hardware Dealer

Full particulars on request

In Solid Brass (per set) the equipment for one casement sash or transom \$2.25  
Rust-proofed Steel " " " " " " " " \$1.75

### VINCENT WHITNEY COMPANY

Western offices:  
365 Market Street  
San Francisco



Eastern offices:  
636-642 Mass. Trust Bldg.  
Boston

Send all inquiries to nearer Office.

Copyright 1925, H. E. Holbrook Co.

WHEN WRITING ADVERTISERS PLEASE MENTION THE AMERICAN BUILDER



WHITCO makes it easy and safe to clean the outside of a casement window from within the room.

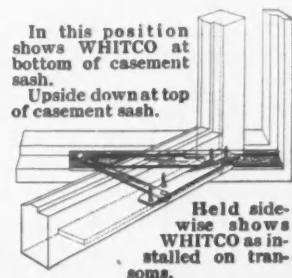

In this position shows WHITCO at bottom of casement sash.  
Upside down at top of casement sash.

Held side-wise shows WHITCO as installed on transoms.

# Cyclone Shingle

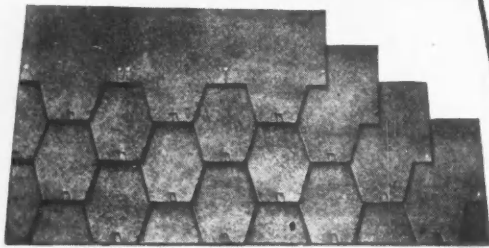

## Note these Advantages

- 1 Only 72 shingles to the square. This means a marked reduction in cost of application.
- 2 216 nails to the square—a proved saving of one pound per square.
- 3 6 7/10 inch head lap and 5 inch side lap make leakage practically impossible.
- 4 Double locked butts positively prevent cup, curl or blow-up.
- 5 2, 3 and 4 thick, assuring years of satisfactory wear.
- 6 In quality the peer of the best asphalt strip shingles. Yet they cost no more.

BIRCH A. B. GEDHART

**Weisenberger-Wegenhart**  
HOME BUILDERS AND REAL ESTATE SERVICE  
207 SECOND NATIONAL BANK BUILDING  
9th and MAIN STREETS  
PHONE, CANAL 1202

LEDA BARLOW  
SALES MANAGER

Cincinnati, O.      January 30, 1925.

The Baldwin Tarvin Co.,  
Cincinnati, O.

Gentlemen;

You may be interested to know that the "Cyclone" shingle you furnished on our job #23 located on Elberon Avenue was put on the roof in about one third of the time required to lay ordinary roof shingles.

As this saving is naturally a big item to the builder, together with the fact that the lock feature of this shingle is a very desirable one, you will readily appreciate that recommending the "Cyclone" is mutually profitable to both builder and home buyer.

Very truly yours,  
WEISENBERGER & WEGENHART.  
By *Edw. Wegenhart*

## "Saves 1/3"

— Say these builders

**Cyclone** is sweeping the country. From far and near come enthusiastic letters like the one above. Why miss out on a good thing? Get the facts! Mail the coupon—RIGHT NOW—for full information regarding this remarkable labor and material saver. No obligation, of course.

FORD ROOFING PRODUCTS CO., Dept. 103,  
535-539 South Franklin Street, Chicago, Illinois  
Please send me details of the **Cyclone** Shingle  
and full particulars, **FREE** and absolutely without obligation.

Name .....

Address .....

Business .....



# SCREEN FACTORY EQUIPMENT

## COMPLETE LINE OF

- BRAD DRIVING TOOLS
- GLUE BRUSHES
- GLUE POTS (Electric)
- CRAYONS
- CORRUGATED  
FASTENERS
- CLAMPING BENCHES
- GLAZIER'S POINTS
- GLAZIER'S POINT  
DRIVERS
- HAND SCREWS, WOOD &  
STEEL SPINDLE
- MALLETS, RUBBER
- MITRE CUTTERS  
(Foot and Hand Power)
- MORTISERS
- NUMERAL NAILS
- SCREEN HANGERS
- SCREEN HARDWARE
- TRIMMERS
- VICES, UNIVERSAL  
AND
- NUMEROUS OTHER  
WOODWORKERS'  
SPECIALTIES

## CARPENTERS, CONTRACTORS and BUILDERS

Write for particulars about our "Easy Time Payment Plan," for equipping a Modern Screen Factory.  
BIG PROFITS IN SCREENS—START AT ONCE.

Write for Our Complete Catalog on Screen Factory Equipment

**LOU MARKWELL CO.** 75 STEUART STREET, SAN FRANCISCO, CALIF.  
174 FRANKLIN STREET, NEW YORK, N. Y.

See our "Ad" on page 220.

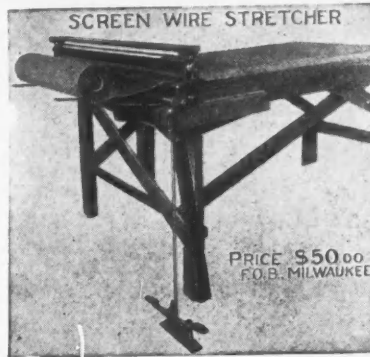

A very convenient and quick operating device for stretching screen wire. It stretches the wire and holds it while tacking, until it is released. It is operated entirely by foot, and works faster and far better than home made devices. Makes your screens 100% perfect. Will take any width wire up to 48 inches but can be built larger if desired. Portable and Stationary Models.

PRICE \$50.00  
F.O.B. MILWAUKEE

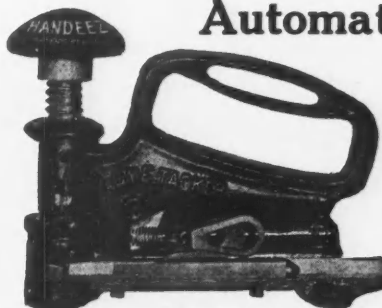

## Automatic Screen Tacker

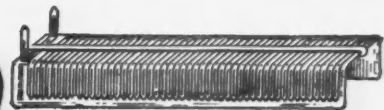

**8 Times Faster Than  
the Hammer and  
Tack**

A slight pressure of the hand drives a broad flat double pointed staple into hard or soft wood. Staple Straddles Five Strands of Wire. No banging of fingers and no waste. Holds twice as strong as tacks. Screen manufacturers now using the ACME use three staples in place of five tacks.

### A World Beater for Tacking Tags on Shipments

MODEL "C"—as illustrated above—(For Flat Surface Lumber).....	\$7.00
MODEL "E"—(For Flat and Rabbeted Lumber).....	8.00
Staples, 30,000 lots, per M.....	.49
Staples, 60,000 lots, per M.....	.43
Staples, 125,000 lots, per M.....	.38
Staples, 250,000 lots, per M.....	.35

Prices on Larger Quantities on Request  
Pure Copper Staples, 10 Cents Per Thousand Higher  
PRICES ARE F. O. B., NEW YORK  
PRICES F. O. B. SAN FRANCISCO ARE SLIGHTLY HIGHER

## Moulding Mitre Cutter

This Handy Tool is Filling a Long  
Felt Want With Window Screen  
Makers

It cuts smooth both ends of a strip in less time than it can be dropped in a mitre box, and does it right every time. It is operated entirely by foot and is so simple that anybody can operate it.

Price \$35 F. O. B. Milwaukee



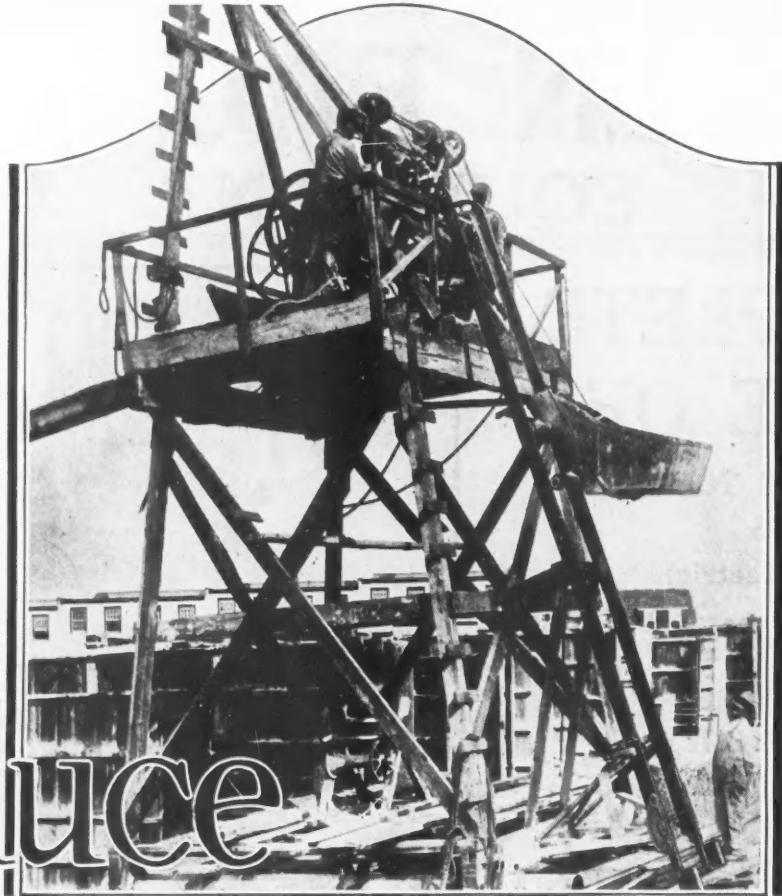

# Reduce Distribution Costs by pouring concrete from an elevated WONDER

**A** WONDER Mixer located five, ten or fifteen feet above your materials and discharging directly into the forms reduces the cost of mixed concrete distribution and largely eliminates wheelbarrow hauling.

The standard track loader used on a WONDER Mixer makes this possible to any reasonable elevation by simply extending the track rails. This extension may be added at any time.

This is a very desirable feature and thousands of contractors are using WONDER Mixers with extended loaders to reduce their distribution costs.

The WONDER catalog fully describes the WONDER track loader and its many advantages. It also contains illustrations of the various uses to which this extension feature is being applied.

Send for your copy today!

**CONSTRUCTION**  
103 VINTON ST.

1910-1925  
*The Original  
and Standard  
for 15 years*

**MACHINERY CO.**  
WATERLOO, IOWA

*Branch Offices With Stocks at*

LOS ANGELES, INDIANAPOLIS, PHILADELPHIA

WHEN WRITING ADVERTISERS PLEASE MENTION THE AMERICAN BUILDER

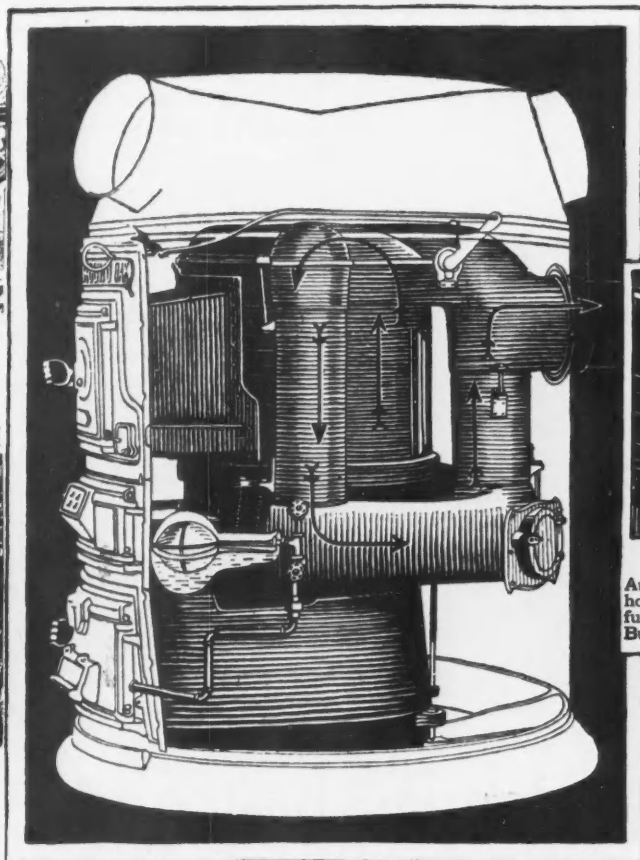

**The Round Oak Automatic Humidifier**  
 Automatically moistens the air of the home. Supplied on all *Round Oak* furnaces — "Moist-Air" and "Iron-Built."



# ROUND OAK

## MOIST AIR HEATING SYSTEMS

**Heat the Home —  
 Humidify the Heat  
 —Ventilate as they  
 Heat and Humidify**

Install these nationally famous Heating Systems in the homes you build and you will satisfy the most particular buyer and have no comebacks.

They are individually planned for the homes they are designed to heat—and built to produce this heat healthfully and economically.

It pays to fight for good heating equipment in the homes you build. Let us send you the latest catalogs on **ROUND OAK MOIST AIR HEATING SYSTEMS**

**THE BECKWITH COMPANY**  
 DOWAGIAC, MICH.

"Round Oak Folks"

Established 1871

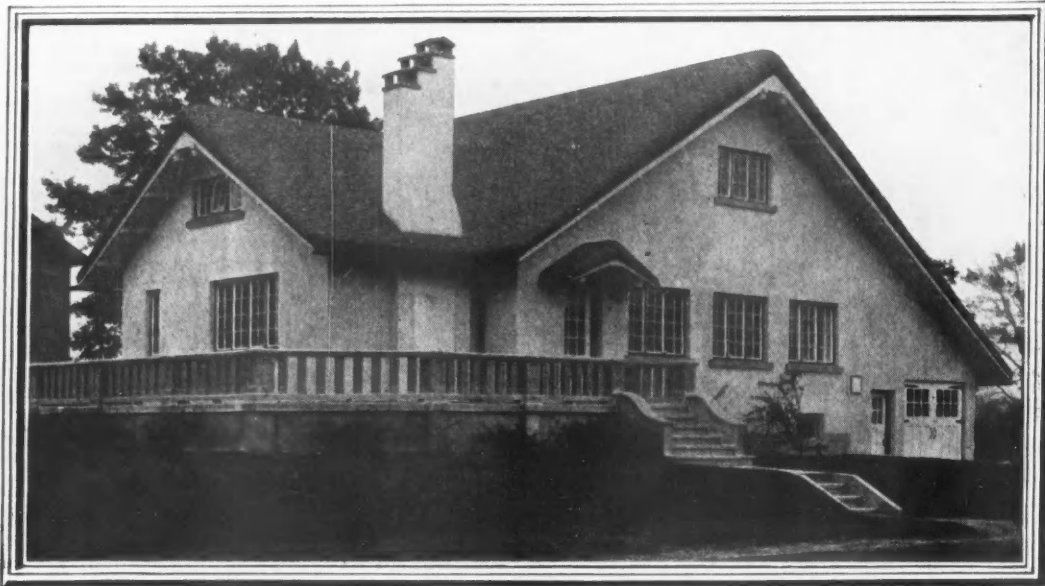

## One man planned, built and owns this home thatched with Winthrops

When Mr. H. J. Maughn, Inglewood Drive, Toronto, decided to build a home he could judge materials from the points of view of architect, contractor and owner. He planned, built and owns the home shown above.

When he selected Winthrop Tapered Asphalt Shingles for this thatched roof, he

knew—as architect—that they would give him—as owner—the striking effect he wished. He knew, too—as contractor—that he would experience no difficulties in laying the roof.

As owner he was sure of the beauty, durability and general satisfaction his roof would give him.

*-the  
Big Butt  
Shingle*



## Winthrop Tapered Asphalt Shingles

The strongest quality feature ever put into any slate-surfaced asphalt shingle is the exclusive, distinctive taper found only in the Winthrop.

This taper not only causes them to snuggle closer to the roof but offers the greatest thickness where exposed to weather and possible firebrands.

These thick butts, due to extra coats of asphalt on both sides of the heavy felt core, cast the attractive shadow lines that made the old wooden shingles popu-

lar. Deeply imbedded crushed slate gives the outside surface beautiful and lasting colors—tile-red, sea-green, blue-black and golden-buff.

*When laid over old shingle roofs, Winthrops have no equal for re-roofing.*

We want you to have a *free* sample of this beautiful shingle, to feel and see its goodness and beauty for yourself.

Just tell us what color you'd like to have.

## Beckman-Dawson Roofing Company

832 F. C. Austin Bldg., 111 W. Jackson Blvd., Chicago, Ill.

*Also manufactured by*

## Lockport Paper Co., Lockport, New York



No. 4L Kwik-Mix Mixer equipped with side loader and water tank. Suited for general all around work. Has a capacity of 4 cubic feet of mixed materials.



No. 3T Kwik-Mix Trailer can be furnished with either pneumatic or cushion tires and can easily be moved from job to job.

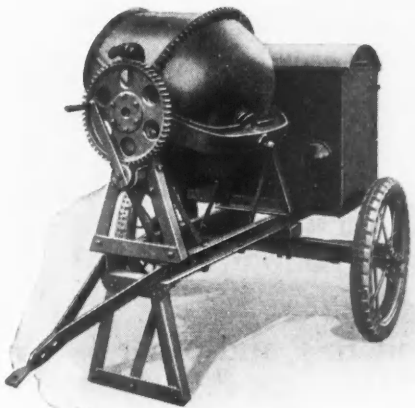

There is a complete line of Kwik-Mix tilting mixers ranging from the small No. 2 to the No. 5L.

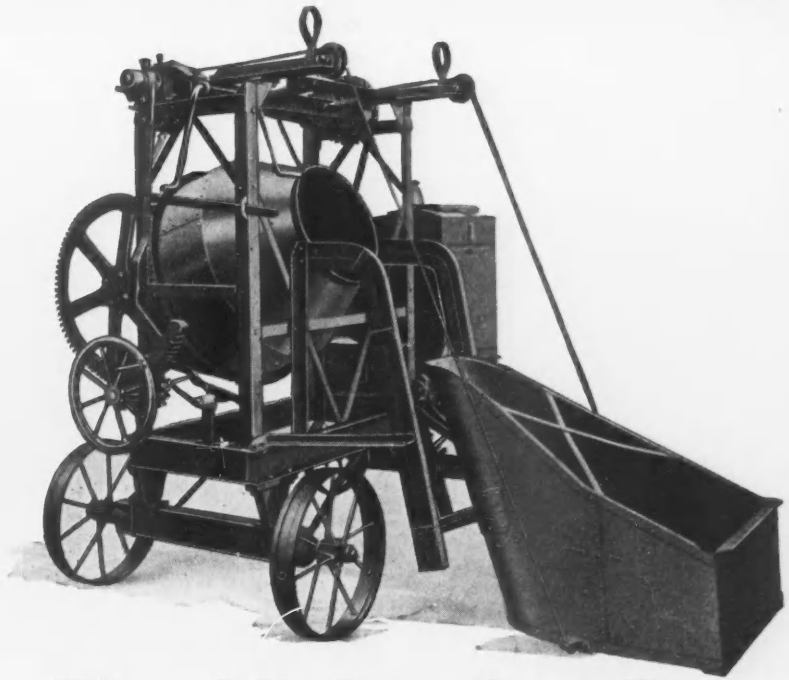

## The Mighty One-Bag Tilting Mixer

Get the most from a One-Bag Tilter by getting the Kwik-Mix 5L Mixer. This husky, over-sized, powerful mixer is able to economically pour "heavy concrete jobs" where one-bag mixers are required. It is a real buy.

Contractors are now using the Kwik-Mix 5L for heavy duty mixing such as pouring concrete for bridges, heavy foundations and flooring. Because it is compactly built, it can be put high up on scaffolding for heavy duty or in the basement for "clean-up" work.

The Kwik-Mix 5L has an oversized mixing drum revolving on Hyatt Roller Bearings, four steel mixing blades, durable frame construction and dependable and surplus power.

*Get our latest circular covering specifically the advantage of this mixer.*

# The Kwik-Mix Co.

Concrete Mixer

PORT WASHINGTON, WISCONSIN

WHEN WRITING ADVERTISERS PLEASE MENTION THE AMERICAN BUILDER

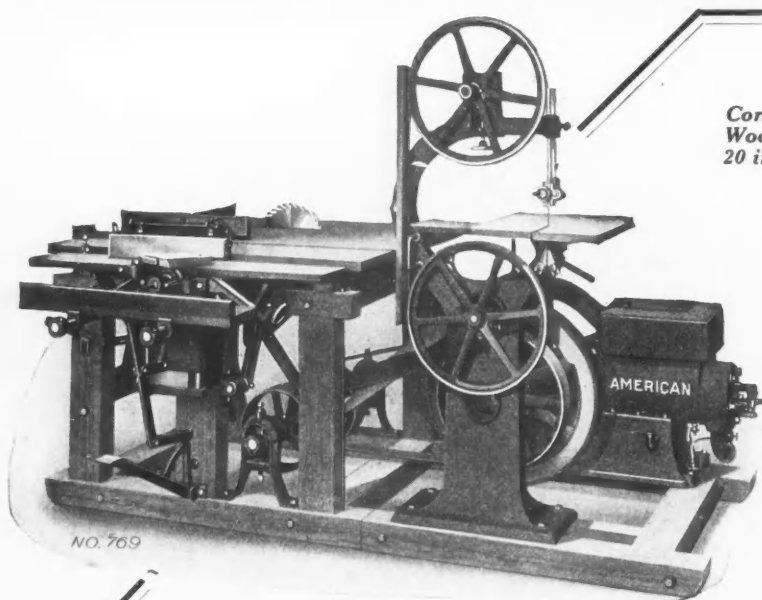

*Contractors' Variety  
Woodworker with  
20 inch scroll Saw*

## Cuts any kind of lumber— and, say!—how it cuts costs!

**T**HIS American Portable Variety Woodworker is letting hundreds of contractors figure low on jobs. And clear up bigger profits, too! No slow hand sawing for them. No waiting on the nearest shop for special jobs. Instead, they have a complete woodworking plant right at hand. Four men can work at it at once.

This one machine may be used as a rip, cutoff, or 20-inch scroll saw, as a dado, gaining, grooving, rabbeting, tenoning, or boring machine, as a jointer or planer, a matcher, molder, or sander, and as a hollow chisel mortiser.

Our Bulletin No. 80 describes in detail this and other time-saving "American" machines. Write for it.

## American Saw Mill Machinery Co.

60 Main Street, Hackettstown, N. J.  
1360 Hudson Terminal Bldg.  
New York City

*"American" Contractors'  
Variety Woodworker*

Manufacturers of wood-  
working machinery for use  
on the job or in the shop

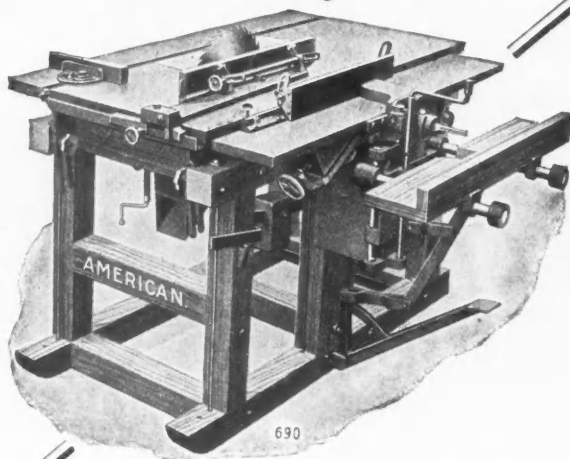

# Make More Money - Be a Bigger Builder

The Good Things—the Big Things—of Life are for those who will reach out for them. You can have them for the grasping—just an energetic thought—saying "I Will" and they are yours. Are you content to make a small profit slowly on hand labor or—will you make a large profit quickly by means of a modern machine? Which?



## Let The Magic Mixer - Mix Your Concrete



Does it faster—better—cheaper

This Mixer will put you in position to do all kinds and classes of concrete work. It will enable you to work faster, do more work, do bigger work, do better work—and will help you build up a permanent and substantial business.

# \$ 25

BRINGS IT TO YOU

Balance on Aloe's Easy Rental Purchase Plan—you have TEN MONTHS TO PAY—and the mixer will be making money for you faster than the easy payments come due. Certainly this is a rare opportunity for you to get away from the old shovel method and get into the class of the big men who are doing the big jobs in the modern way.

**FREE TRIAL**

## WHICH?

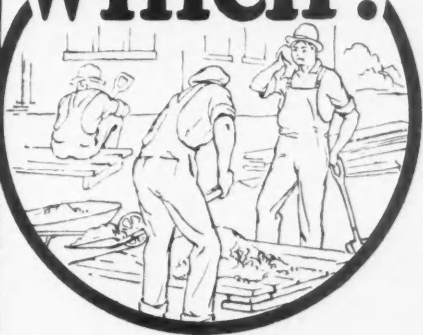

## YOUR BIG OPPORTUNITY for BIGGER SUCCESS

With this wonderful machine and two men you can do as much work as you formerly did with six men. And you can do it easier, quicker and better, producing an absolutely uniform batch every time. It will mix 4½ to 5½ cubic feet per batch—can be speeded up to a batch every minute—over 2,000 cubic feet per day. It is the most practical and efficient mixer made—scientifically constructed of the best materials—light in weight, portable, simple and durable. Backed by the Aloe iron-clad guarantee to give the utmost service and satisfaction.

### The Engine

Fitted with 2½ horse-power four cycle, horizontal gasoline engine with high-grade Webster magneto. Simple, powerful, reliable, economical—requires only two gallons gasoline a day. Protected by all-steel housing. Two doors at rear make it easy to get at.

### Comes Complete

Nothing complicated—nothing to get out of order. Can be operated by anyone who will read and follow the simple directions which are furnished with each mixer. It comes complete—ready for work the day you get it.

# FREE



### Free Trial—Easy Terms

So confident are we the Magic Mixer will please you in every way we will gladly send it to you for 10 DAYS FREE TRIAL on payment of only \$25.00. Take it out on your jobs—put it to the most severe tests. Then, if you can be induced to part with it again ship it back at our expense—and we will promptly return your money without a word.

### Get This FREE Book

You ought to have this booklet of invaluable facts about the wonderful opportunities the Magic Mixer offers you. Sent FREE together with full particulars of our Easy Rental Purchase Plan by which the Magic Mixer will pay for itself and put you on the road to greater success at the same time. Get this remarkable offer.

## INVESTIGATE NOW!

The road to success is open to you. The opportunity to make yourself a big man is before you. The simple act of signing and mailing this coupon may be the turning point of your career. Don't sit idly by while other men are forging to the front. Start the coupon on its way. Get the facts. The time to act is NOW.

**A. S. ALOE CO.**  
621 Olive St., St. Louis, Mo.

## MAIL COUPON TODAY

A. S. ALOE CO.  
621 Olive St., St. Louis, Mo.

Send me FREE booklet, "The Concrete Road to Success", full description of the Magic Concrete Mixer and particulars of your Easy Rental Purchase Plan.

Name: \_\_\_\_\_

Address: \_\_\_\_\_

# Builders have found a new use for Ambler Linabestos Wallboard

They've been cutting it into strips and applying it as clapboards. We are now meeting this demand by putting out these clapboard strips already bored for nailing, 6 in. by 8 ft. in the Dutch siding and 8 in. by 8 ft. in the Colonial.

This means that Ambler Linabestos Wallboard—a permanent building material that does not require paint and gives absolute fire protection—can be used at a great saving in labor as the exterior finish for some of the most popular designs of homes. The color is a light buff, just what many people prefer, anyhow.

Ambler Linabestos Wallboard has a wide variety of uses in interior construction. Years of use will find partitions of this material without unsightly cracks, because there is nothing about it to warp, twist or shrink. It comes in sheets 48" by 48" and 48" by 96,"<sup>3</sup>/<sub>16</sub> in. or <sup>1</sup>/<sub>4</sub> in. thick, can be applied by carpenters and can be readily sawed and nailed with ordinary tools.

Furnished in press-scored sheets which can be enameled in a tile-like finish, this material is used for the wainscoting of bathrooms, kitchens and laundries. It is unaffected by steam, heat or cold.

Send for samples of this material and let us help you to solve your building problems.

## Asbestos Shingle, Slate, and Sheathing Company

Department A

Ambler, Penna.

*Branch Offices:*—Baltimore, Boston, Buffalo, Chicago, Cincinnati, Columbus, Detroit, Cleveland, Minneapolis, New York, Omaha, Philadelphia, Pittsburgh, Washington, Wilkes-Barre; Toronto, Canada; Havana, Cuba.

*Southwestern Distributor:*—R. V. Aycock Co., Kansas City, St. Louis, Tulsa, Houston.

*Southeastern Distributor:*—Berry Asbestos Co., Atlanta, Ga.

*California Representative:*—J. A. Drummond, Los Angeles, San Francisco. H. G. Sperry & Company, Utah, Idaho, Nevada, and Washington Representative: Offices—Salt Lake City and Seattle.

F. T. Crowe & Company, Washington Representative: Offices—Seattle and Tacoma. Dixie Asbestos Co., Birmingham, Ala.

*Other distributors throughout the country.*

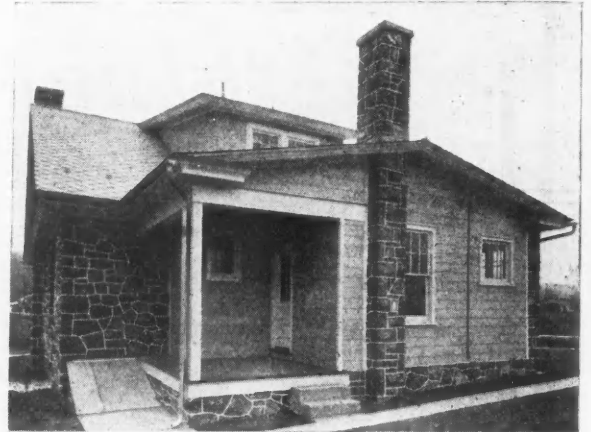

Showing Application of Linabestos Clapboard

## ASBESTOS CANNOT BURN

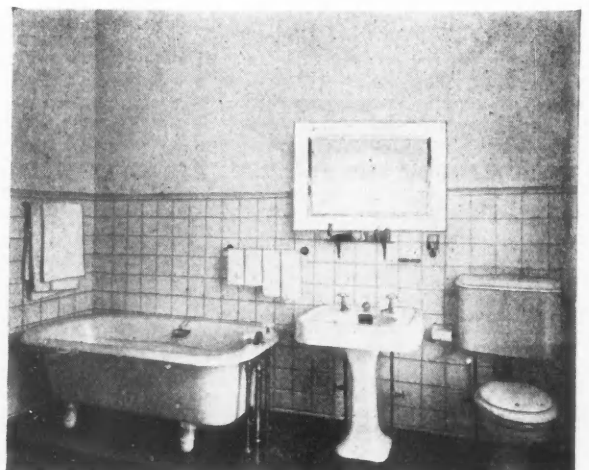

Interior of Bathroom with press scored Linabestos

WHEN WRITING ADVERTISERS PLEASE MENTION THE AMERICAN BUILDER





This group of six houses is kept comfortable by hot water radiator warmth, with ARCO Boilers and American Radiators.



This group of six houses depends for its heat on hot air furnaces and registers.

# SIDE BY SIDE

*One group sold - Why not the other?*

THOMAS V. RAY, the Buffalo builder, says: "At the time we built these two groups of houses, which are side by side, we tried to save some money by installing hot air in six and IDEAL Boilers in the other six.

"We soon realized this was expensive economy. The six houses in which we installed IDEAL Boilers and AMERICAN Radiators sold within six months from the time they were built, while now, after two years, we still have three of the hot air houses left.

"Our new houses are all to be equipped with IDEAL Boilers and AMERICAN Radiators."

Everywhere builders and realtors, like Mr. Ray, have found that the house with an IDEAL Boiler and AMERICAN Radiators not only sells more easily, but that it usually sells for *more* and rents for more than the house with less efficient heating equipment.

Radiator warmth is a salesman. Try it.

## AMERICAN RADIATOR COMPANY

Dept. T86, 1807 Elmwood Avenue, Buffalo, N.Y.

Sales offices in all principal cities

IDEAL BOILERS AND AMERICAN RADIATORS FOR EVERY HEATING NEED

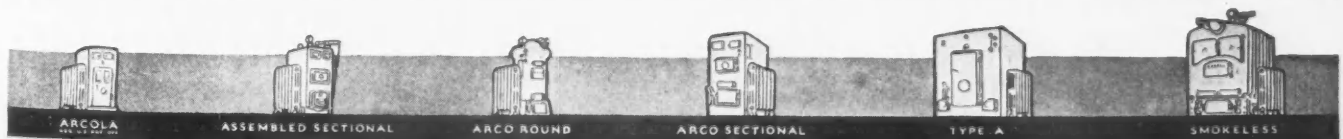

WHEN WRITING ADVERTISERS PLEASE MENTION THE AMERICAN BUILDER



## Le Roi Repair Cost on Hoists!

Le Roi Engines' claim to dependable power is an earned one. It is backed by performance. Think of it—all Le Roi Engines on hoists showed a repair cost of only 57c an engine per year. This figure covers the past four years when construction equipment more than ever had to perform dependably and constantly to safeguard the contractor's profit.

An engine that shows such a surprisingly low up-keep cost must be reliable—it is not guilty of costly shutdowns. And, likewise, does not throw a husky crew into idleness. The Le Roi does this exacting service because it is built right—made with all the painstaking care and precision known

to engine builders. Every Le Roi that leaves the plant successfully passes all tests and inspections and is fit for duty.

Even though Le Roi Engines are made in three sizes ranging from 3 to 15 H. P., 85 percent of the parts are interchangeable.

**Le Roi Company, Milwaukee**

# LE ROI ENGINES

**for dependable power!**

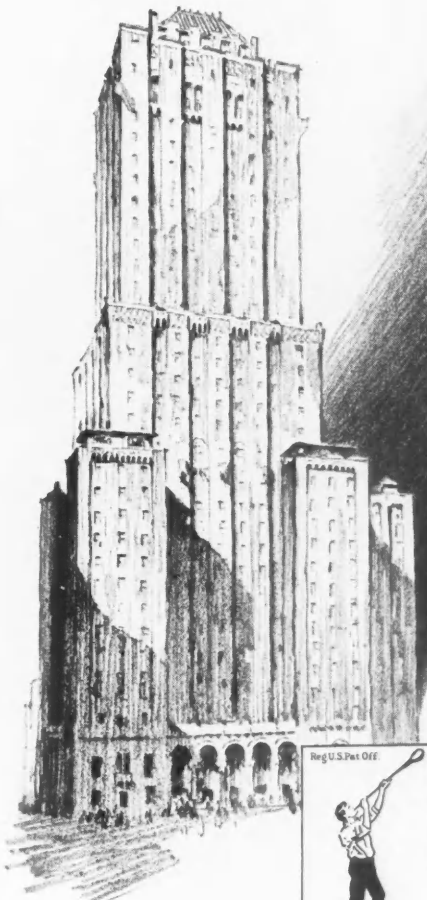

The Shelton Hotel, New York City (the tallest hotel in the world), in which a large percentage of the fixtures installed are equipped with MONAX GLASS, including the famous Ainsworth "Archer Model." Arthur Loomis Harmon, New York City, Architect. Shelton Holding Corporation, New York City, Builder and Owner.

## The Shadow Chaser

**H**OTEL ILLUMINATION that produces gloomy Shadow interferes with the performance of service, detracts from general appearance of interiors and ultimately makes for dissatisfied guests. Only by writing exact specifications can it be certain that a lighting system will provide light that is adequate, efficient and cheerful—free from glare.

MONAX GLASS, "The Shadow Chaser," sprays light *uniformly* in all directions yet absorbs almost none of it. MONAX is an artistic glassware in a wide variety of design. Easy to clean, its lighting efficiency can always be maintained.

*Have your specification writer send for illustrated catalog and professional specification sheet in ready-to-file form*

MACBETH-EVANS GLASS COMPANY

(Eastern Division)

CHARLEROI, PENNSYLVANIA

# MONAX GLASS

for Hotel Lighting

# Nature has done you a good turn

In your conscientious endeavor to give the utmost in value and service in the buildings you plan and construct, nature has made it possible to furnish perfect walls.

In a restricted area in Northwestern Ohio there is a deposit of limestone which has never been equalled for purity and quality.

In the limestone quarried from this district, there is a "something" in the natural composition of the rock which makes lime of amazing properties—extra fine in texture, truly wonderful in placticity (spreadability) pure white in appearance, extra strong in setting and as enduring as the ages.

Nature alone is responsible for this exceptional quality. Our long lime-making experience merely tends to carefully retain this splendid quality from the quarry to your walls.

This wonderful finishing lime is available anywhere and at any time. Specify it and use it. It will satisfy all concerned—the architect, the contractor, the plasterer and the man for whom the building is constructed.

Just ask for any one of our three brands—the quality is in the limestone.



**The Woodville Lime Products Co.**

645 Madison Avenue  
TOLEDO, OHIO

White Enamel  
Gold Medal and  
White Lily.

Finishing

Hydrated  
Lime

*"The Quality  
is in the Limestone"*





# Wallace Machines for Profits



Wallace  
Portable  
6" Jointer

**E**VERY season is a busy season for the carpenter-contractor equipped with Wallace Portable Machines, for they can be profitably employed turning out mill work in the shop whenever they are not busy out on a construction job. This man makes a fine profit making fluted porch posts during the dull season.

### Eliminate Competition

You can get the edge on competition with the help of your Wallace Machines, for your costs are lower and less time is required to finish the job. These facts enable you to underbid your competitors and still make a larger profit than they could, while doing work of uniformly higher grade.

### Fast and Accurate

Wallace Portable Machines are fast on even the largest operation within their respective capacities. At the same time they are absolutely accurate on the smallest jobs,—jobs which could not be handled at all on a big machine. You can put a Wallace Saw or Jointer into the back of a Ford and have it working on the job in a few minutes.

### Economical

Wallace Portable Machines are economical in first cost—a full set of them can be purchased for little more than the cost of one large machine of similar high grade construction. They are also exceedingly low in operating cost. They take their power from any light or power circuit, and are all direct-motor-driven—no belts to slip.

### Wallace Portable Machines

- |  |                       |
|--|-----------------------|
| Wallace 6" Jointer                       | Wallace Universal Saw |
| Wallace 4" Planer                        | Wallace Plain Saw     |
| Wallace 6" Lathe                         | Wallace 16" Band Saw  |
| Wallace Disc Sander                      | Wonder Spindle Sander |
| Wallace Glue Pot, automatic heat control |                       |

Write for Catalog 402C and price list.

**J. D. Wallace & Co.** 136 S. California Ave.  
CHICAGO, U. S. A.

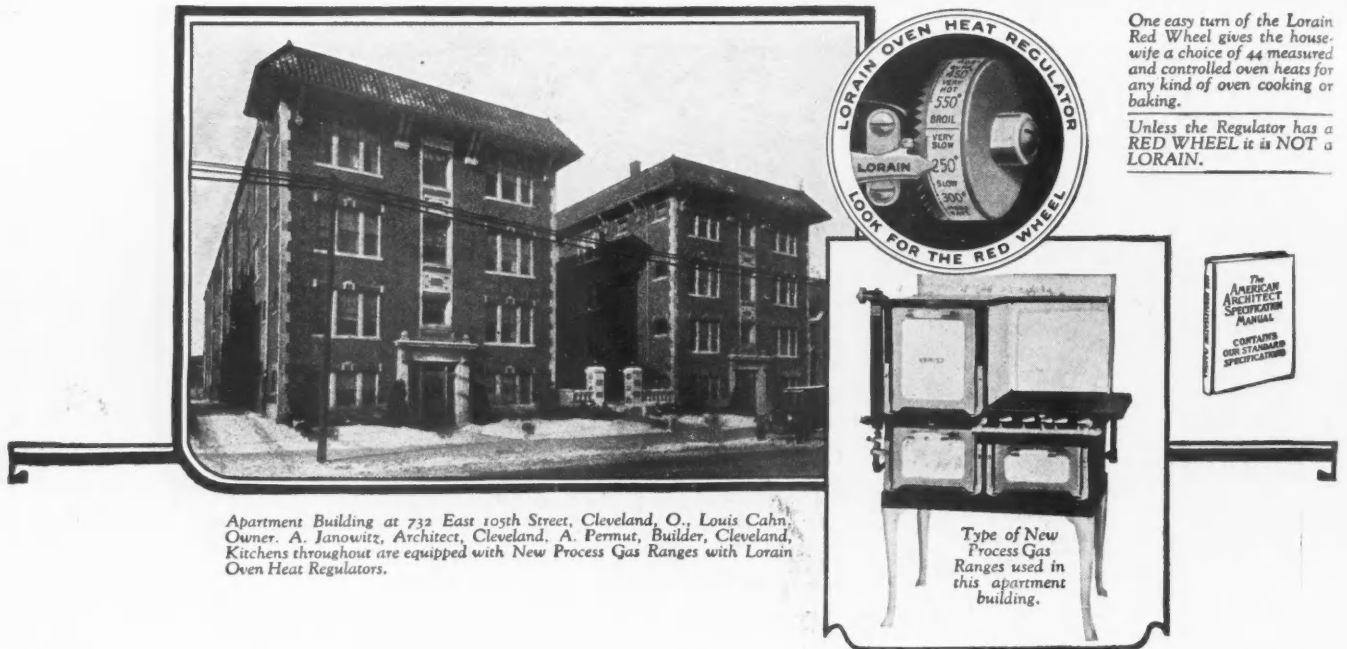

Apartment Building at 732 East 105th Street, Cleveland, O., Louis Cahn, Owner. A. Janowitz, Architect, Cleveland. A. Permut, Builder, Cleveland. Kitchens throughout are equipped with New Process Gas Ranges with Lorain Oven Heat Regulators.

Unless the Regulator has a RED WHEEL it is NOT a LORAIN.

Type of New Process Gas Ranges used in this apartment building.

## To Architects: Here are 10 Excellent Reasons for Installing Lorain-equipped Gas Ranges

EVERY time an architect selects certain equipment for the building he designs, he has a good reason for that selection. Perhaps in some instances he has two or three or even four reasons. If he has *ten* reasons then it's good evidence that the equipment must be as near perfect as possible.

Well, there are at least *ten good* reasons for the installation of Gas Ranges equipped with the Lorain Oven Heat Regulator, in structures where food is to be cooked and baked. These are:

1. A Lorain Self-Regulating Oven enables the housewife to "set" the heat of the oven at any cooking temperature—and that temperature will be automatically maintained *exactly* until the gas is turned off.
2. Lorain enables the housewife to Bake, Boil, Roast and Can in the oven by the "Time and Temperature Method", which assures perfect results every time.
3. Lorain enables her to cook a Whole Meal at one time while she is miles away for hours. Everything will be deliciously done and ready to serve when she returns.
4. Lorain enables her to can fruits and tomatoes in the oven—easier, better and quicker than by any other method.
5. Lorain saves Food, Fuel, Time and Labor.
6. Lorain is easy to operate.
7. Lorain never gets out of order.
8. Lorain will last as long as the Range itself.
9. Lorain is endorsed by nationally-known cookery experts.
10. Lorain-equipped Gas Ranges are used in thousands upon thousands of homes—and by over 1300 schools and universities for instruction in Cookery.

If you want to build houses, apartment buildings or any other type of modern structure where the cookery equipment must be the "last word" in efficiency, install Lorain-equipped Gas Ranges. For specific data as to sizes, styles, finishes, etc., see 19th Edition, Sweet's Catalog, pages 2497-2506 inclusive. Other information will be gladly sent on request.

These famous gas stoves are equipped with the Lorain Oven Heat Regulator: Clark Jewel, Dangler, Direct Action, New Process, Quick Meal and Reliable.

AMERICAN STOVE COMPANY, 233 Chouteau Avenue, St. Louis, Mo.  
*Largest Makers of Gas Ranges in the World*

# LORAIN OVEN HEAT REGULATOR

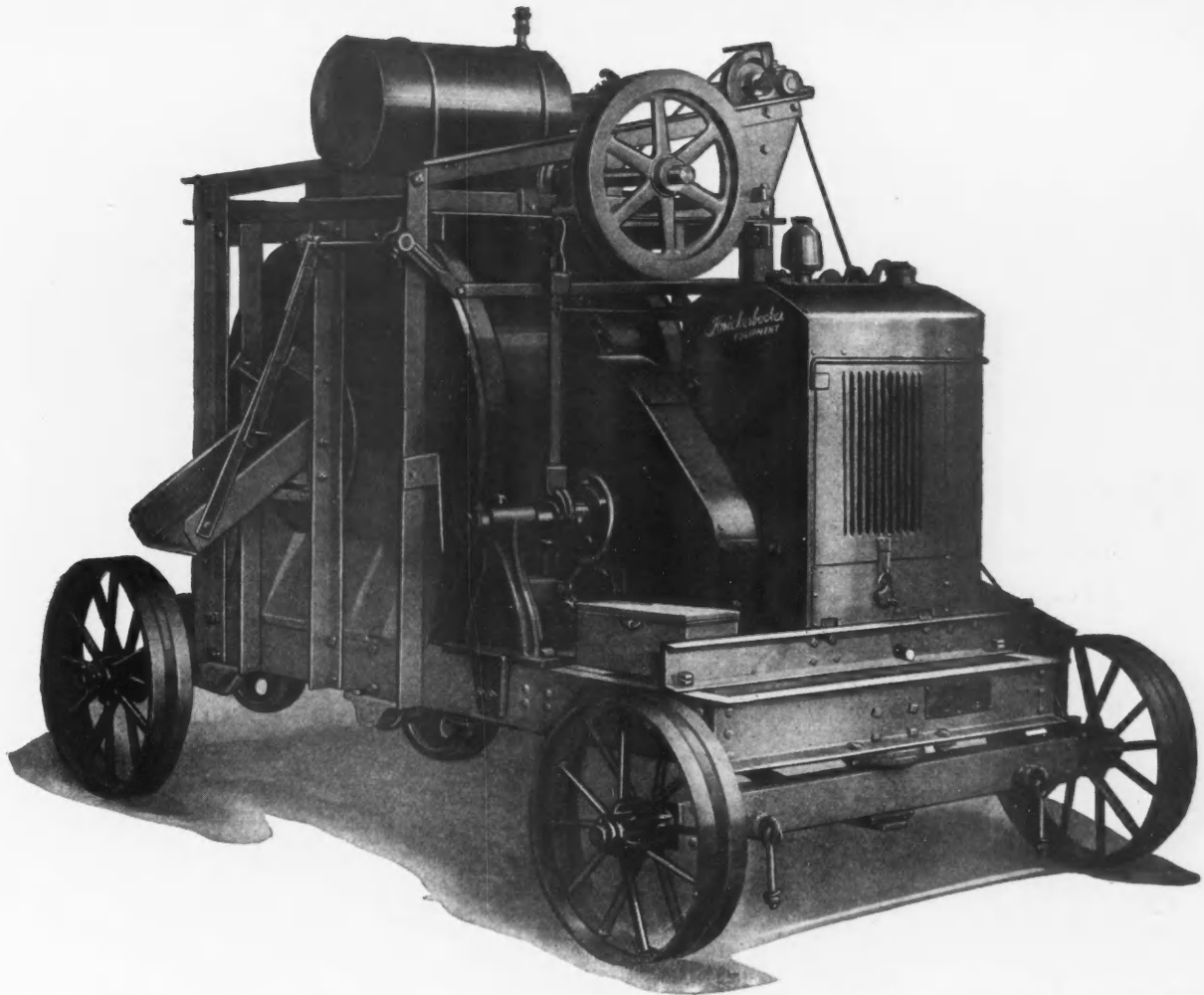

# KNICKERBOCKER

## *The Un-Skimped\* Mixer*

There's only one idea governing the design and construction of Knickerbocker Mixers—to give the contractor the best possible machine of its capacity, at a price that will make it "a good buy."

This matter of price (what you pay for the machine) depends upon cost (what it costs us to build it).

We could eliminate the over-size drum dimensions.

We could reduce the number of mixing buckets.

We could change the angle of the discharge, make the charging opening smaller and less slop-proof.

We could eliminate the sub-hopper.

We could use a plain spool for winding the cable.

We could use old-fashioned grease cups, instead of Alemite.

We could build of lighter channels, angles, shafting, plates, castings, wheels.

We could equip it with a hopper-cooled engine.

We could do a lot of things to cut the cost to us and cut the price to you—but then it wouldn't be a Knickerbocker Mixer!

*If you need concrete mixers, mortar mixers, plaster mixers or woodworkers, get the Knickerbocker catalog.*



### KNICKERBOCKER FEATURES

Over-size Drum.  
Extra Discharging Buckets.  
Drum speed, 18 R.P.M.  
Multiple mixing action for every revolution.  
Wide discharge chute, 55 deg. pitch.  
Worm cable sheaves—cable doesn't wear against itself.  
Bearing units replaced on the job.  
Alemite lubrication.  
LeRoi radiator-cooled engine.  
Complete one-man control.  
Every possible delay guarded against.

★ Hard to say, important to remember!



The Knickerbocker Company - 525 Liberty Street, Jackson, Michigan



**Does your town fulfill your dreams?**  
*These facts and figures indicate how you can help*



THE officials of your town, looking ahead and planning for a better and more attractive community, need your encouragement. These guiding facts, collected by the Lehigh Portland Cement Company, will indicate how you can help secure improvements that will bring permanent satisfaction.

A reputation for good schools is a great town builder. It brings a desirable type of newcomers, as Ridgewood, New Jersey,

discovered. In 1915 this town planned for fire-safe schools, selecting the most modern forms of construction. All schools built under this plan make liberal use of concrete in various forms—pre-cast concrete for trim. Every possible precaution was taken to ensure fire-safety and to prevent needless expenditure of the town's money for maintenance. Since 1915, the population has increased 40%, and as an indication of the type of (over)

Continued from preceding page

newcomer, it is estimated 15% of the new doors now open their own homes.

When building new schools in your town, avoid there are school fees every day, including for the most serious diseases. Your children will be safe in schools when foundations, floors, sidewalks and partitions are of fire-safe concrete.

Tell the officials how you feel about the roads in your community. Encourage them to build for permanent satisfaction. Here are some facts you can quote them.

I appreciate, by the Great State Highway Commission for work on from 8 to 15 years on an street or highway where the traffic is equivalent to 4.00 tons per day. Annual maintenance charges on concrete were found to be 25% less than on other types of construction. Consider consumption and wear on iron over concrete roads were also found in range from 15% to 50% less than on the gravel and dirt roads.

Say Harbor, N. Y. The value of property—simple improvements like stooping walls, concrete garages and other suggestions you will find on the list at the right of this page.

**How to get permanent satisfaction, whatever you build**

**[1] Get dependable materials**  
 Reputation for dependability has made Lehigh Cement the largest-selling cement in the world. Last year, contractors, engineers, architects and owners used over 68 million sacks. Lehigh building materials recognize this point.

The dealer who insists on carrying Lehigh for you, shows due to the fact of constant pressure to offer you the "just at good" brand. It is not reasonable to expect a dealer of this type to protect your interests in other ways also by handling a line of thoroughly dependable materials. Get the blue-and-white Lehigh sign and you get a reliable dealer.

**[2] Get competent workmanship**  
 Even with the best materials you can get poor results unless you secure competent workmanship.

A good contractor will save you money through skillful building economies. He will put quality both where it can be seen at the start and also where it will be covered for its long exposure in the years to come.

It goes to remember in choosing a contractor. The contractor who insists on dependable materials is likely to hire competent help and to put skill and dependability into all that he does.

**LEHIGH PORTLAND CEMENT COMPANY**  
 ALLENTOWN, PA. BIRMINGHAM, ALA. CHICAGO, ILL. SPOKANE, WASH.  
 New York Buffalo Kansas City New Orleans, La. Philadelphia  
 Miami City, Fla. Omaha Pittsburgh Richmond St. Louis



THE NATIONAL CEMENT 16 Mills from Coast to Coast

concrete pavement on Main Street. A remarkable increase in business resulted. People who previously patronized contractors now purchase their supplies from Sag Harbor merchants, while the "move" and hotels have been taxed to capacity.

**Being permanent satisfaction into your home**  
 After all, your community is judged by the pride you and your neighbors take in the appearance of your homes and the advantages of owning your own home will not be lost. Like anything else worth while, when you buy, hold or sell your home, you take risks. You may lose or gain pleasure and advantage through your construction. Its very few year and increasing as time goes on. Make certain of permanent satisfaction. Avoid heavy, unnecessary repairs.

If not quite satisfied with your home, a few study-made improvements can change discontent into real satisfaction. Improvements made surprising additions in the value of your property—simple improvements like stooping walls, concrete garages and other suggestions you will find on the list at the right of this page.

Concrete pavements on Main Street. A remarkable increase in business resulted. People who previously patronized contractors now purchase their supplies from Sag Harbor merchants, while the "move" and hotels have been taxed to capacity.



**Make Concrete of LEHIGH CEMENT for Permanent Satisfaction**

- When you own a home, you take risks. You may lose or gain pleasure and advantage through your construction. Its very few year and increasing as time goes on. Make certain of permanent satisfaction. Avoid heavy, unnecessary repairs.
- Of concrete pavements—on streets, sidewalks, and driveways.
  - Of concrete foundations—under basements and porches.
  - Of concrete floors—on porches, patios, and terraces.
  - Of concrete stooping walls—on porches, patios, and terraces.
  - Of concrete garages—on porches, patios, and terraces.
  - Of concrete steps—on porches, patios, and terraces.
  - Of concrete sills—on porches, patios, and terraces.
  - Of concrete curbs—on porches, patios, and terraces.
  - Of concrete gutters—on porches, patios, and terraces.
  - Of concrete downspouts—on porches, patios, and terraces.
  - Of concrete drains—on porches, patios, and terraces.
  - Of concrete gutters—on porches, patios, and terraces.
  - Of concrete downspouts—on porches, patios, and terraces.
  - Of concrete drains—on porches, patios, and terraces.
  - Of concrete gutters—on porches, patios, and terraces.
  - Of concrete downspouts—on porches, patios, and terraces.
  - Of concrete drains—on porches, patios, and terraces.

# Reinforcing the contractor

**T**HE contractor now has a strong champion in print. The Lehigh advertising tells his story to his customers. It appears in March in the Saturday Evening Post, Literary Digest and in other publications of general circulation.

It says to his customers:

"A good contractor will save you money through skillful building economies. He will put quality both where it can be seen at the start and also where it will be noticed for its low repair expenses in the years to come.

A point to remember in choosing a contractor:  
 The contractor who insists on dependable materials is likely to hire competent help and to put skill and dependability into all that he does."

This helps you build your reputation for giving permanent satisfaction with every job—so does the quality of the cement you use.

Lehigh Cement is always dependable, always uniform, available from coast to coast, wherever desired. It is the product of the largest company of its kind in the world.

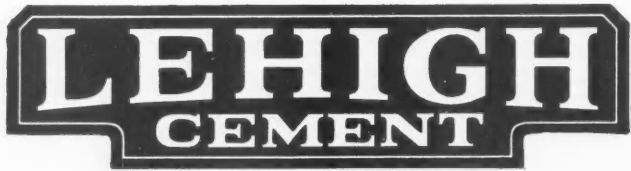

**LEHIGH PORTLAND CEMENT COMPANY**  
 ALLENTOWN, PA. BIRMINGHAM, ALA. CHICAGO, ILL. SPOKANE, WASH.



# for ROOFS

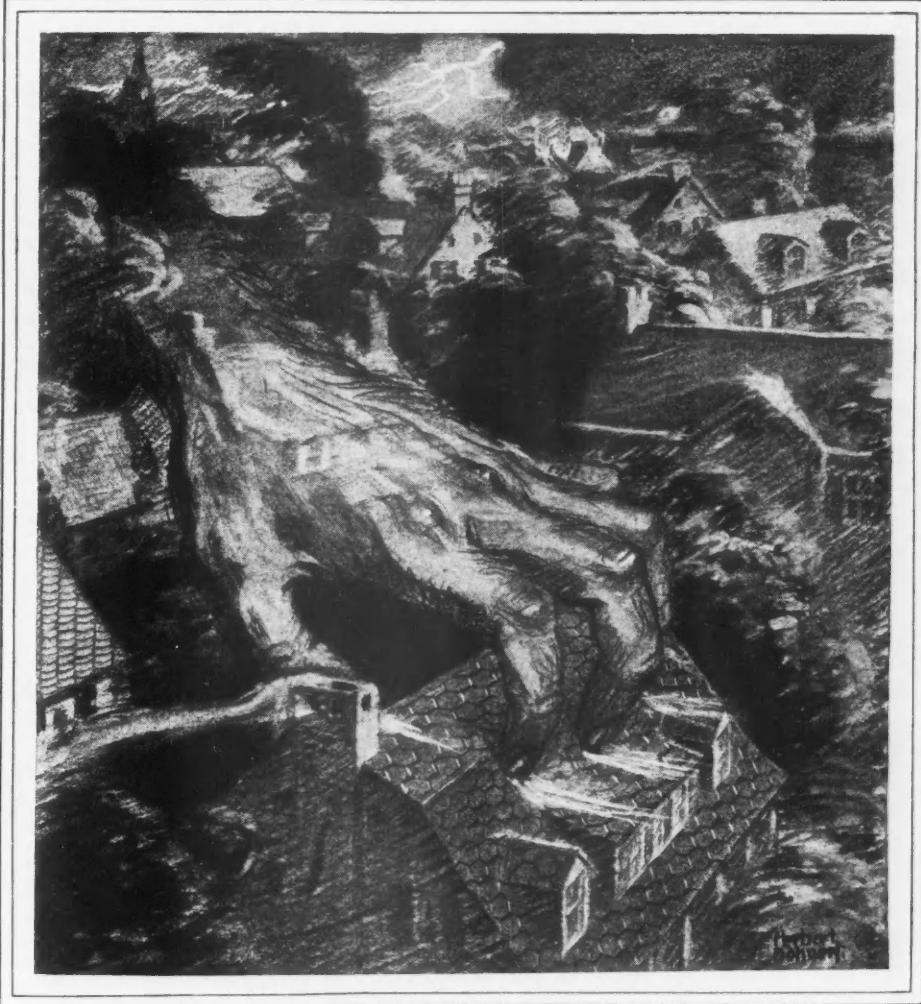

## Will Your Roof Stand This Abuse?

From the icy blasts of winter, from the blistering rays of the sun; through wind-driven rain and beating sleet, insidiously and unceasingly, the elements are striving to claw through the roof above your head. Will the roofing you use stand this abuse—year after year?

You can know, definitely, before you spend a cent for roofing or a penny for repairs. Write for a sample of Beaver Vulcanite Slate-surfaced Roofing. (1) Twist it, bend it. (2) Kick it, scuff it. (3) Lay it on ice, then pour hot water on it. (4) Leave it on a hot radiator. (5) Soak it in

water. (6) Put burning embers on it.

Prove by these six daring tests that Beaver Vulcanite Roofing will not crack, "run," peel or curl under the most severe climatic conditions. Convince yourself that this husky, tough, fire-safe roofing will easily endure the abuse of actual use. Then compare it for quality, price and beauty.

Check and mail the coupon for samples and a copy of "Style in Roofs"—a comprehensive treatise on the proper type, design, finish and color of your roof. Mail the coupon now.

# BEAVER

PRODUCTS



WHEN WRITING ADVERTISERS PLEASE MENTION THE AMERICAN BUILDER

## BEAVER PRODUCTS

....

### for ROOFS

Slate-surfaced Shingles and Slabs in many colors and designs

Special Re-roofing Shingles

Slate and Smooth-surfaced Roll Roofing—in weights and finishes for every use

Built-to-order Roofs

Roof Paints and Cements

....

### for WALLS

Beaver American Plaster

Beaver Gypsum Lath

Beaver Plaster Wall Board

Bestwall

Gypsum Partition Block

Beaver Fibre Wall Board

Beaver Tile Board

Varnishes and Enamels for industrial use

....

Samples and descriptions

## FREE!

The Beaver Products Co. Inc.  
Buffalo, N. Y., Dept. M-3

Gentlemen: Please send me your book, "Style in Roofs," and samples of Beaver Vulcanite Roofing. I am also interested in other Beaver Products listed below:

Name .....

Address .....

City ..... State .....

## An Invitation to Architects, Builders, Draftsmen and Architectural Students to Participate in a COMPETITION FOR SMALL FIRE-RESISTIVE HOUSES

	Prizes	
	Class A	Class B
First Prize .....	\$500	\$500
Second Prize .....	300	300
Third Prize .....	200	200
Fourth Prize .....	100	100
10 Mentions in each class .....	50 each	50 each

### COMPETITION CLOSSES APRIL 15, 1925

Contestants may submit as many designs as they wish in either or both classes. In case of a tie for any of the prizes offered the full amount of the prize tied for will be awarded each tying contestant.

### PURPOSE OF THIS COMPETITION

1. To further encourage a higher standard of design and plan of the average American home, which because of its moderate cost is often built without the benefit of competent individual architectural service. Through the medium of this competition, it is hoped to make available a large variety of architecturally good small house designs in fire-safe construction to meet requirements in all sections of the country.

2. To widely introduce a new form of fire-resisting, permanent and economical construction through the use of Structolite Concrete construction. This is an improved method of fire-resistive construction for **walls, floors, partitions and roof**, adaptable for all classes of residences.

Structolite Concrete is a mixture of Structolite (a form of gypsum possessing great structural strength) with various recommended aggregates to form a rapidly setting mix for pouring monolithic construction. The structural result offers an exceptional combination of high compressive strength and light weight.

### COMPETITION PROGRAM

#### Class A—Five-Room Bungalow

**Plan**—Shall contain living room and dining room (separate or combined); two or three bedrooms; kitchen and bath. Front entrance into hall, vestibule or living room. Service entrance separate. Cellar optional.

**Size**—Including porches and projections, not to exceed 20,000 cubic feet in accordance with measuring system given below.

**Cost**—Not to exceed 50c per cubic foot.

**Exterior Walls**—Must be Structolite Concrete faced with stucco, brick, stone, shingles or siding. Choice absolutely optional.

**Partitions, Floors and Roofs**—Materials optional.

#### Class B—Six-Room, 2-Story Dwelling

**Plan**—Shall contain living room, dining room, kitchen, three bedrooms and one or two baths. Front entrance into hall, vestibule or living room. Service entrance separate. Cellar required.

**Size**—Including porches and projections, not to exceed 30,000 cubic feet in accordance with measuring system given below.

**Cost**—Not to exceed 50c per cubic foot.

**Exterior Walls**—Must be Structolite Concrete faced with stucco, brick, stone, shingles or siding. Choice absolutely optional.

**Partitions, Floors and Roofs**—Materials optional.

#### Requirements for Both Classes A and B

With the exception of the exterior walls (which must be planned and specified for Structolite Concrete) all construction and equipment may be optional in accordance with good architectural and building practice.

**Closets**—There shall be one closet for each bedroom, one for linen and one for coats.

**Size of Rooms**—Only one bedroom can be smaller than 120 sq. ft. in area and this one not less than 90 sq. ft. All other room sizes optional.

**Porches**—Optional.

**Measurement of Cubic Footage**—Measurements must be taken from the outside face of exterior walls and from the level of the cellar floor (or from grade where cellar is omitted in bungalows) to the average height of all roofs as measured to a point one half the distance from the highest cornice to the ridge. Porches, if used, are to be figured at one-fourth of their total gross cubage if they project beyond the bearing walls and at full cubage if within the bearing walls, height to be measured from finished grade.

**All cubage figures will be carefully checked before submitting to the jury, and plans exceeding the maximum will not be considered.**

**Style and Location**—The designer is free to use any style he prefers for either Northern or Southern climates, and location may be corner or inside as no plot plans are required. As Structolite Concrete is a structural material which will take any facing equally well, it is left to the designer's discretion to use for facing any of the following materials, stucco, brick, stone, shingles or siding.

#### Competition Drawing Required

There shall be but one drawing on a sheet of white paper measuring 20x26 inches, with plain black border lines drawn 1 inch from edges, giving a space within the border lines of 18x24 inches. Tracing paper, mounted paper or cardboard prohibited. There should be a pen and ink perspective of the house projected

### NOTE

This Competition, having been ruled by the American Institute of Architects' Committee on Competitions to be one of an educational nature, is to be treated as an exception within the meaning of the Institutes' Circular of Advice. This ruling implies no opinion whatever by the A. I. A. Committee as to the merit of any materials or methods of construction.

A booklet giving Structolite Concrete Details will be supplied on request to United States Gypsum Company, 205 West Monroe Street, Chicago.

**This Competition Conducted by the Architectural Forum for  
UNITED STATES GYPSUM COMPANY**

from a quarter-inch scale plan and without wash or color. The principal floor plans shall be drawn at a scale of 8 feet to the inch. A detail of one exterior feature shall be shown and a small vertical section giving ceiling and roof heights.

The plans must be blacked in solid and accompanied by a graphic scale. On the plan each room shall be named and dimensions given in clear lettering large enough to be easily legible.

Each kitchen plan must show the location of range, sink and cupboard. **A separate service entry is required in which the ice box shall be located.**

In a space enclosed with border line give computation of cubage figures, and notes suggesting exterior color scheme, stating briefly material selected for facing and roofing. All figures and notes to be made large enough to permit of a three-quarter reduction.

The drawings shall be in black ink; the presentation should be simple and the plans drawn clearly because of their future use in published form for the public. The drawings shall be titled—

Design for a Six-Room Structolite Concrete House  
(or Five-Room Structolite Concrete Bungalow)

and signed by a nom de plume or device. It should be accompanied by a sealed envelope bearing the nom de plume and containing the true name and address of the contestant. Drawings may be delivered flat or rolled, packed to prevent creasing or crushing. (Deliver to Structolite Concrete Competition, care of The Architectural Forum, 383 Madison Avenue, New York.) **Must be received on or before April 15th, 1925.** Drawings submitted in this competition are at owner's risk from the time they are sent until returned although reasonable care will be exercised in their handling and keeping.

All competition drawings are to remain property of the contestants. The right is reserved by United States Gypsum Company to publish or exhibit them as required. The full name and address of the designer will be given in connection with each design published. Drawings will be returned to the contestants direct from the office of The Architectural Forum at the time when they are released by United States Gypsum Company.

Prize drawings will be published in The Architectural Forum. It is a condition of this competition that each contestant who is awarded a prize or mention, or whose design is selected for publication, agrees to prepare, if requested, in accordance with standard regulations to be given later, a set of working drawings on tracing cloth together with specifications covering his design. These working drawings and specifications shall bear the name of the designer as architect and become the property of United States Gypsum Company. If working drawings and specifications are required, reasonable payment will be made to the designer for such work at an amount to be agreed upon plus a royalty for every sale of a set of his plans by United States Gypsum Company.

### Jury

The designs will be judged by three or five members of the architectural profession, representing different sections of the country. The jury will give consideration to the following points:

**Excellence of plan.  
Attractiveness of design.  
Practicability of construction.  
Domestic efficiency of plan arrangement.**

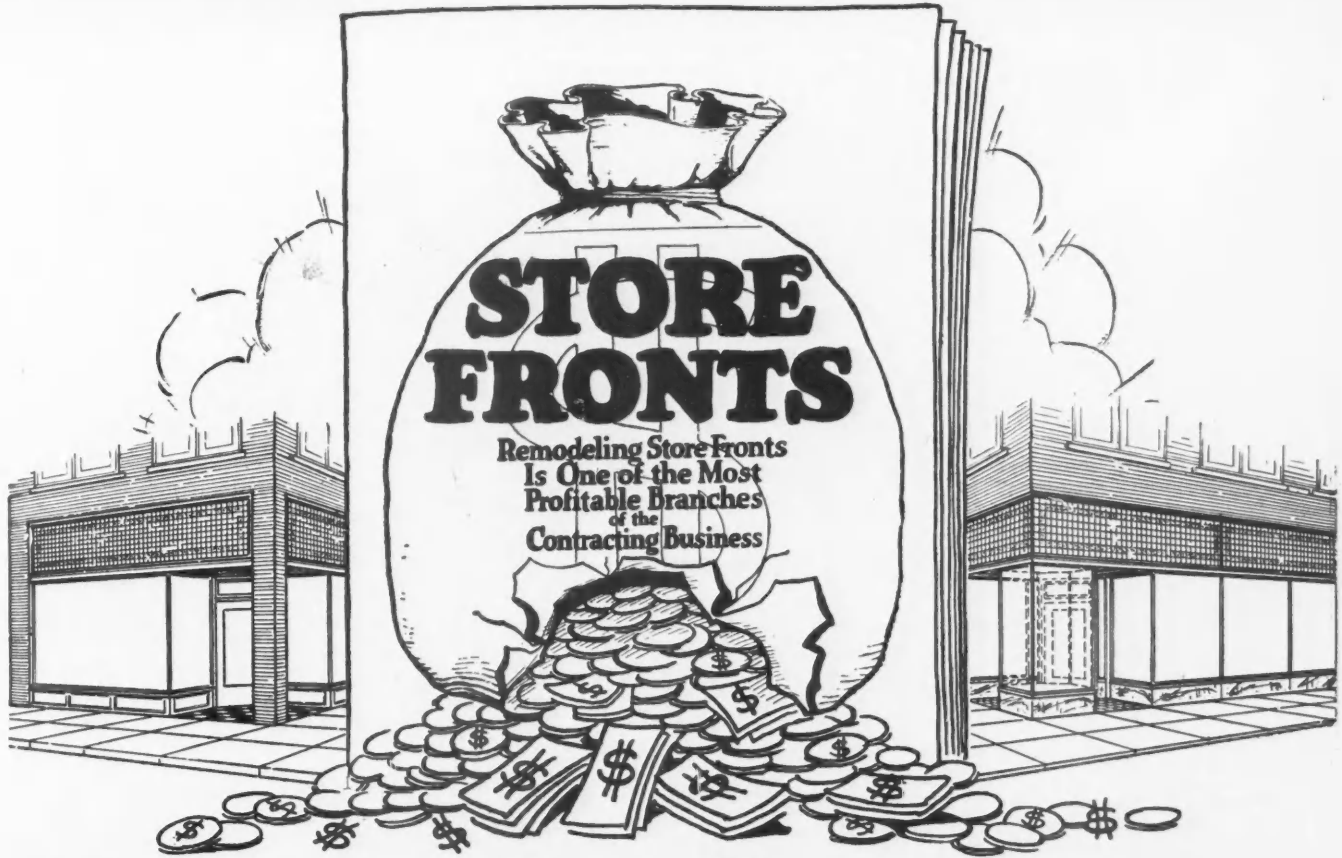

# How to Get Contracts ~ at your own price

Are you working a territory where bids must be cut to the bone in order to secure contracts? Are you tired of taking jobs at prices that pay you mere wages? Then get into the store-front field.

Here's a branch of contracting that is not crowded. Contracts are readily secured at a profitable figure. The work is simple and can be handled by an inexperienced crew.

An hour or two of your time with our free

book on Desco methods will tell you how to enter this interesting and profitable business. Cut-throat competition will no longer cut into your profits. Tear out the coupon below and get into this branch of building while the field is open.

*Write us for the name of the nearest "Desco" Distributor.  
Additional information in Sweet's Catalog.*

**DETROIT SHOW CASE COMPANY**  
1654 FORT STREET WEST, DETROIT, MICHIGAN

181

## Money Making COUPON

Detroit Show Case Company  
1654 Fort St. West, Detroit, Mich.  
Without obligation on my part you may send me your book on "Desco" store fronts.

Name \_\_\_\_\_

Address \_\_\_\_\_

City and State \_\_\_\_\_

Business \_\_\_\_\_

**Desco**  
METAL

*A complete stock of "Desco" construction materials carried in our New York City warehouse, 562 West 52nd Street.*

# STORE FRONTS





F-3  
Wolverine  
Wheel Barrow

# What Makes Wheel Barrow Economy?



"Lansing Equipment for Contractors"

- Mixers
- Batch
- Continuous
- Mortar
- Barrows
- Carts
- Scrapers
- Hoists
- Block
- Machines

CONTAINS COMPLETE INFORMATION



Send for Your Copy

**PRACTICAL** wheel barrow economy obtained from the long experience of America's oldest and largest manufacturer of wheel barrows is found only in Lansing-Company products which have dominated the field for forty-four years.

These important features found in the Contractors Barrows have been best worked out by Lansing-Company engineers; viz:

**THE TRAY**—pressed from a single sheet of steel has a smooth uniform surface. A heavy rod is rolled within the flange on the top edge giving it rugged strength. Some manufacturers flange the top without the rod. The tray is mounted on the handles by hardwood risers.

**HANDLES**—are mounted to such a height as to give the most comfortable operating positions. It is well balanced. A heavy iron yoke connects the handles at the wheel end. The lumber used throughout is a high grade Michigan hard wood.

**WHEELS**—are extra heavy with steel bushings in the hubs and are firmly held by the Lansing-"Never Slip" axle lugs.

**LANSING EQUIPMENT ECONOMY**—is definitely established. This large business has been built up by giving our customers what they want, at reasonable prices, and goods so well made that we have not only retained our old customers but have constantly added to their number.

Ask for special circulars showing contractors barrows—a complete line for every purpose.

LANSING - COMPANY, LANSING, MICHIGAN

BRANCH WAREHOUSES

Chicago

Boston

New York

Philadelphia

Minneapolis

San Francisco

Kansas City



WHEN WRITING ADVERTISERS PLEASE MENTION THE AMERICAN BUILDER





# Profit with "Pearl" NOW!

Many are in need of new screens *now* or can be shown how to add an attractive Sun or Sleeping Porch to their home.

This "PLAN" will help you

To assist you in pointing out to your prospects the simplicity of construction and installation of screened porches, we have prepared a Blue Print of a Porch Plan which we will send free.

Recommend PEARL Wire Cloth for economy it lasts longer, does not bag or sag, requires no painting and insures against repairs. PEARL Wire Cloth is the most universally used and biggest seller in branded screen materials today. Back of the enormous and steadily increasing sales of PEARL is its unusual wear quality due to its metallic coating—a special process owned and controlled exclusively by us.

Genuine PEARL has two Copper Wires in the selvage. Every roll carries OUR ROUND RED TAG,

*We have a dealer in your town. See him or write us if you are interested in screening doors, windows or porches. Samples and literature FREE*

Address Dept. "A"

**THE GILBERT & BENNETT MFG. COMPANY**

New York      Georgetown, Conn.      Chicago      Kansas City

*PEARL is made in REGULAR GRADE (12 x 13 mesh) and 14, 16, 18, 20, 24 and 30 Mesh also EXTRA HEAVY GRADE (14 Mesh only)*

The best hardware dealers in your city sells "PEARL."

Clip and Mail this Coupon

The Gilbert & Bennett Mfg. Co.  
Dept. "A"—Box 760  
CHICAGO, ILL.



Gentlemen:  
Please send me complete information on PEARL WIRE CLOTH and PLAN for screening porches.

Name.....

Street.....

City..... State.....

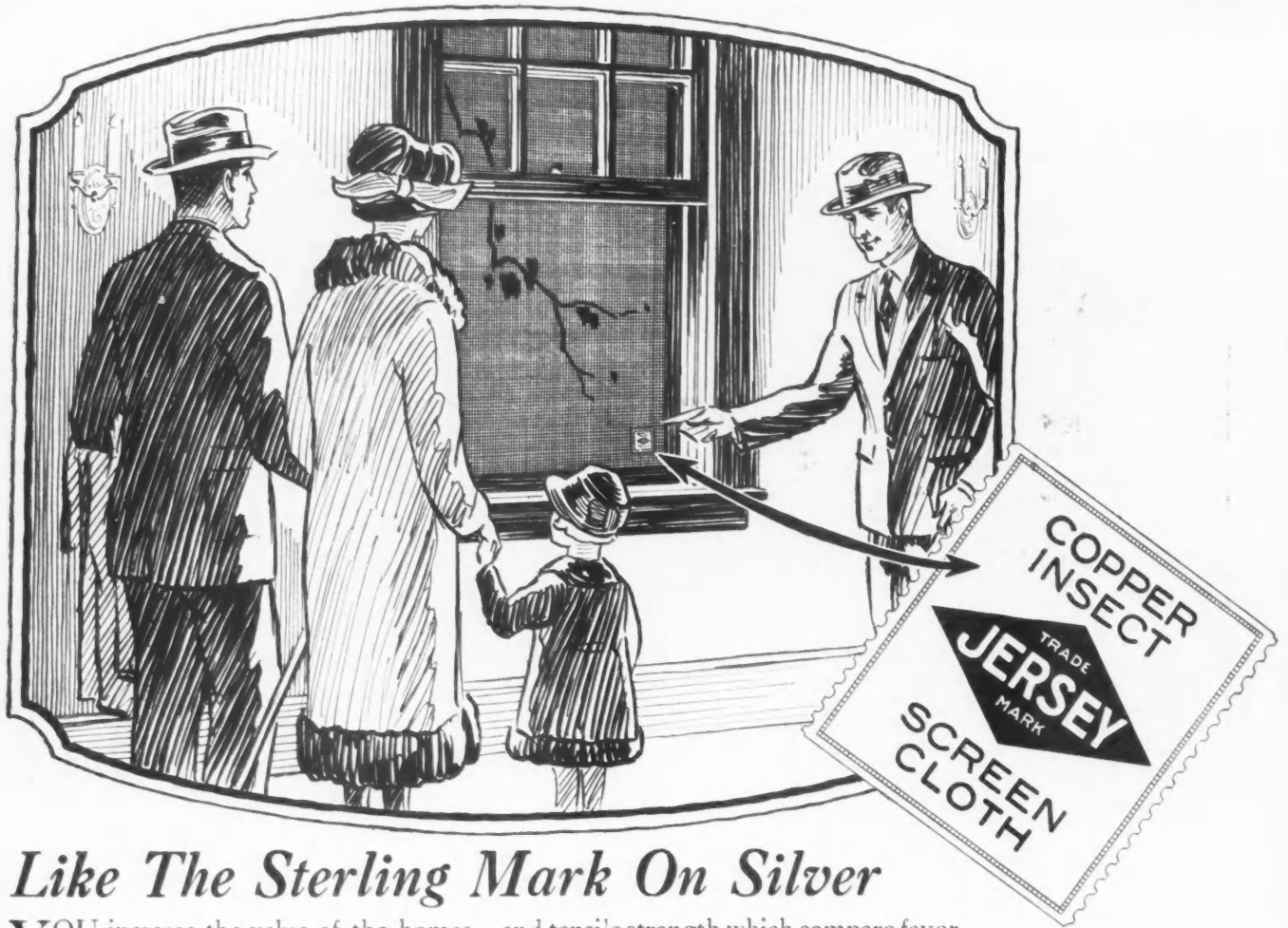

## Like The Sterling Mark On Silver

**Y**ou increase the value of the homes you build when you use materials of known quality and proved dependability.

One of these items which should not be overlooked is the screen cloth for doors, windows and porches. If you can point to the sticker on screens made of Jersey Copper Insect Screen Cloth or the tag on the end of every roll of Jersey, the home builder gives instant approval. The Jersey diamond on screen cloth is like the sterling mark on silver.

Jersey has won its extensive recognition due to inherent quality plus extensive advertising. It cannot rust because it is made of copper 99.8% pure. Due to a special Roebing process, it has stiffness

and tensile strength which compare favorably with steel. In 16 mesh it is a true insect screen cloth because it keeps out not only flies but also mosquitoes and other small insects.

Jersey is made in both bright and dark finishes, but the latter usually appeals to the housewife. It does not have to go through any weathering process. It is as nearly invisible as a screen cloth can be and stays that way.

Jersey Copper Screen Cloth can be obtained from most of the better hardware merchants and custom-made screen makers. If you cannot readily locate a distributor, write us. We will send you samples and tell you where you can get it.



THE NEW JERSEY WIRE CLOTH COMPANY

614 South Broad Street

Trenton

New Jersey

All Grades of Wire Cloth Made of all Kinds of Wire



# Copper Screen Cloth

Made of Copper 99.8% Pure

# 8 reasons Why

*The New*

**PENBERTHY**  
PRODUCTS



## Model "R" Automatic Cellar Drainer

has greater sales possibilities than any other cellar drainer on the market today.

**MORE EFFICIENT:** Will remove more water in less time at lower pressure on the supply.

**MORE ECONOMICAL:** Requires a smaller amount of water for operation.

**MORE RELIABLE:** Positive in action with no delicate parts to wear out or get out of order.

**MORE DURABLE:** Bronze and brass used throughout—nothing to rust or corrode.

**MORE COMPACT:** Requires less sump space than any other drainer.

**MORE POWERFUL:** Long lever increases operating range to 100 pounds.

**MORE ACCESSIBLE:** All working parts easy to get at should it be necessary.

**MORE SALABLE:** Can be used where other cellar drainers would be useless.

Your jobber will supply you.  
Write for details of construction and operation.

# PENBERTHY INJECTOR COMPANY

Established 1886

New York Depot  
71 Beekman St.

**DETROIT**  
Michigan

Canadian Plant  
Windsor, Ontario

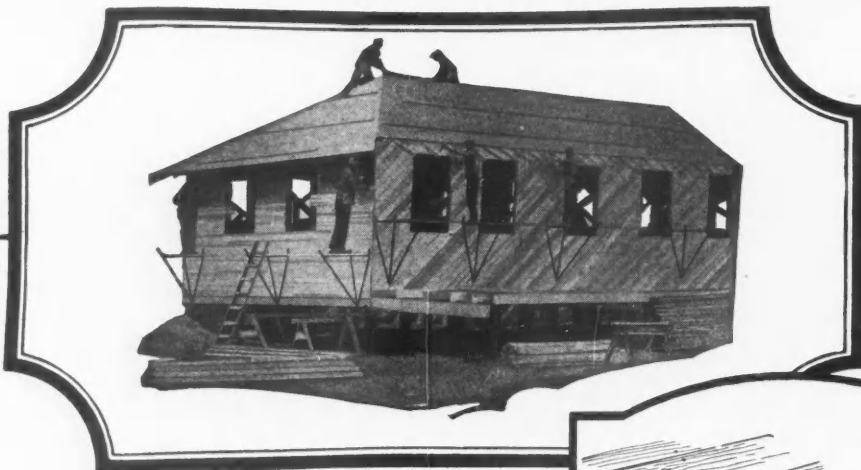

## They Are the Best Scaffold Brackets Made

So writes Mr. M. A. Steinwald, a successful general contractor of Canaan, N. Y. Read his letter which tells what he thinks about Reliable Scaffold Brackets—

Canaan, N. Y.

Elite Mfg. Co.,  
Ashland, Ohio  
Gentlemen:

I do building, painting and jobbing and use a number of your Reliable Scaffold Brackets. I expect to buy more of them some day. Will say that I think they are the best scaffold brackets made. I used them for putting on new roofs, painting roofs, and all kinds of work and find that they are absolutely safe in every way. They are the nicest and easiest brackets to put up that I have ever seen.

Very truly yours  
M. A. STEINWALD

This letter is just like hundreds of letters we are getting all the time. Builders and contractors everywhere are telling us how much safer and more economical Reliable Scaffold Brackets are than the old wooden scaffold.

Send in your order and start saving money now. All of these brackets will save you lots of time and money—Roofing Brackets, Hood Type Bracket, Ladder Bracket, Corner Bracket and the Standard Scaffold Bracket.

Order now. We ship C. O. D. so you can see the brackets before you pay a cent.

ELITE MANUFACTURING COMPANY  
Dept. AB-3 Ashland, Ohio

**Reliable Scaffold Brackets**  
Patented Oct. 4, 1910  
No holes to plug after they are removed

Elite Mfg. Company, AB-3  
Ashland, Ohio

Please send me at your risk C. O. D. the following brackets:

Name .....

Address .....

City ..... State .....

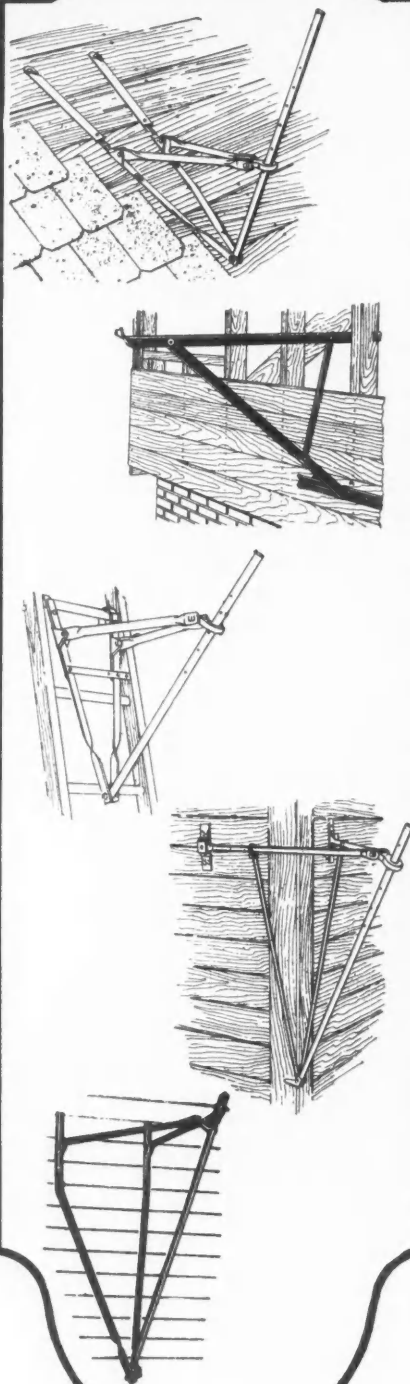



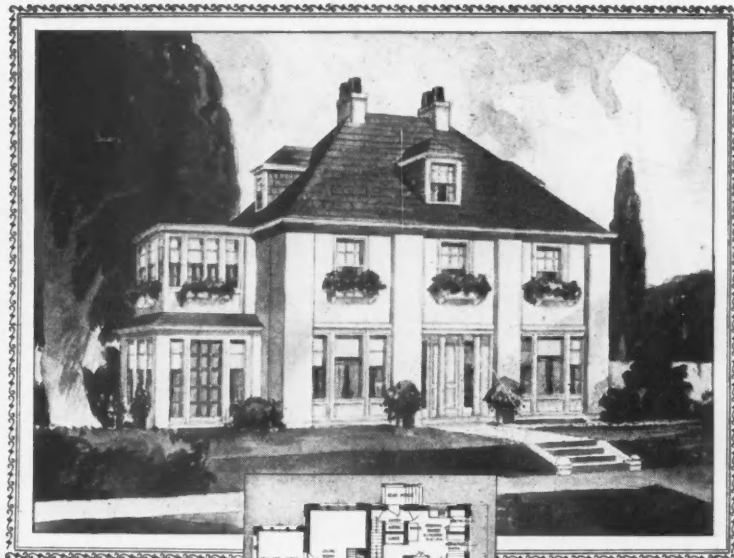

Morgan Mirror Door  
M 888

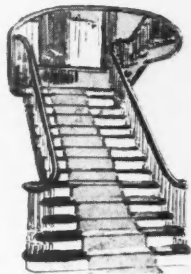

Morgan Stairway  
M 200

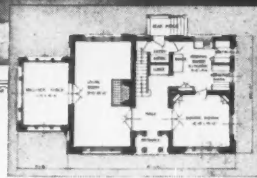

Main Floor Plan  
Morgan Plan Suggestion 25A

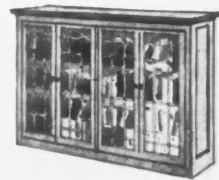

Morgan Bookcase  
M 527

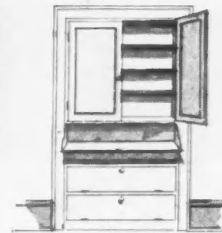

Morgan Linen Case  
M 575

## On the day the last rent check is written

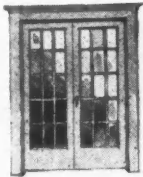

Morgan French  
Doors M 831

With the coming of spring, thousands of "renters" are looking forward eagerly to the day when the last rent check will be written. In the hands of the builder they will leave the countless details that make up their dreams of home. How well those

details are worked out will often spell the difference between a satisfied and a dissatisfied customer.

Do not forget the charming entrance that means so much—the graceful stairway, at once a utility and a beauty spot—the bookcases, mantels, china closet, cupboard, cozy nook, to say nothing of the doors and trim. These are the vital things in the plans—vital to the beauty and comfort of the home.

Don't let just "woodwork" creep into the home specifications. Be careful. Remember that woodwork is a fixture. It cannot be easily torn out or

made over. Once in place, it is difficult and costly to change.

There is one safe way—one simple way—one way that gives you every assurance. Specify "Morgan Quality." Insist that the woodwork bears the famous mark like this **MORGAN** on every piece.

Three generations have made woodwork a lifetime study. Morgan stands for "quality," for great factories, wonderful machinery, vast forests of timber and "standardized" manufacturing methods which cut costs to a minimum.

That is why Morgan Quality is so inexpensive.

Morgan prices are guaranteed for periods of four months, thereby protecting your profits. Our standardized sizes enable you to speed construction.

Write for copy of our current Price Supplement. Or mail coupon for prospectus describing "Building with Assurance."



Morgan Breakfast  
Nook M 391



There is no added cost for "Morgan Quality"

# "MORGAN-QUALITY"

STANDARDIZED WOODWORK

MORGAN WOODWORK ORGANIZATION

MORGAN SASH & DOOR COMPANY, Chicago, Ill.; Detroit, Michigan; Cleveland, Ohio  
MORGAN MILLWORK COMPANY, Baltimore, Md.; Jersey City, N. J.; Greensboro, N. C.  
MORGAN COMPANY, Oshkosh, Wis.; New York City



Look for this mark on every Morgan product

WHEN WRITING ADVERTISERS PLEASE MENTION THE AMERICAN BUILDER



440-page  
Master Book on  
Home Building

"Building with Assurance" (Second Edition) contains the information you need to help you cut costs, save time and avoid mistakes.

"Building with Assurance"

Indorsed by over 15,000  
authorities

This great book shows page after page of homes of all types in colors—with floor plans. The home illustrated above, for example, with complete floor plans, will be found on page 48. In addition, you get help on room arrangement, interior decoration, lighting, heating, plumbing, landscaping, etc.

Mail Coupon for Prospectus

Our prospectus tells all about the book—shows beautiful homes in color, with floor plans. The prospectus is gladly sent free to those who mail the coupon.

Address nearest office, Dept. T-3.

Morgan Sash & Door Company, Chicago, Illinois  
Morgan Millwork Co., Baltimore, Maryland  
Morgan Company, Oshkosh, Wisconsin

Gentlemen: Send me at once, copy of your prospectus which describes "Building with Assurance."

Name .....

Address .....

Town ..... State .....

Business .....

# zinc

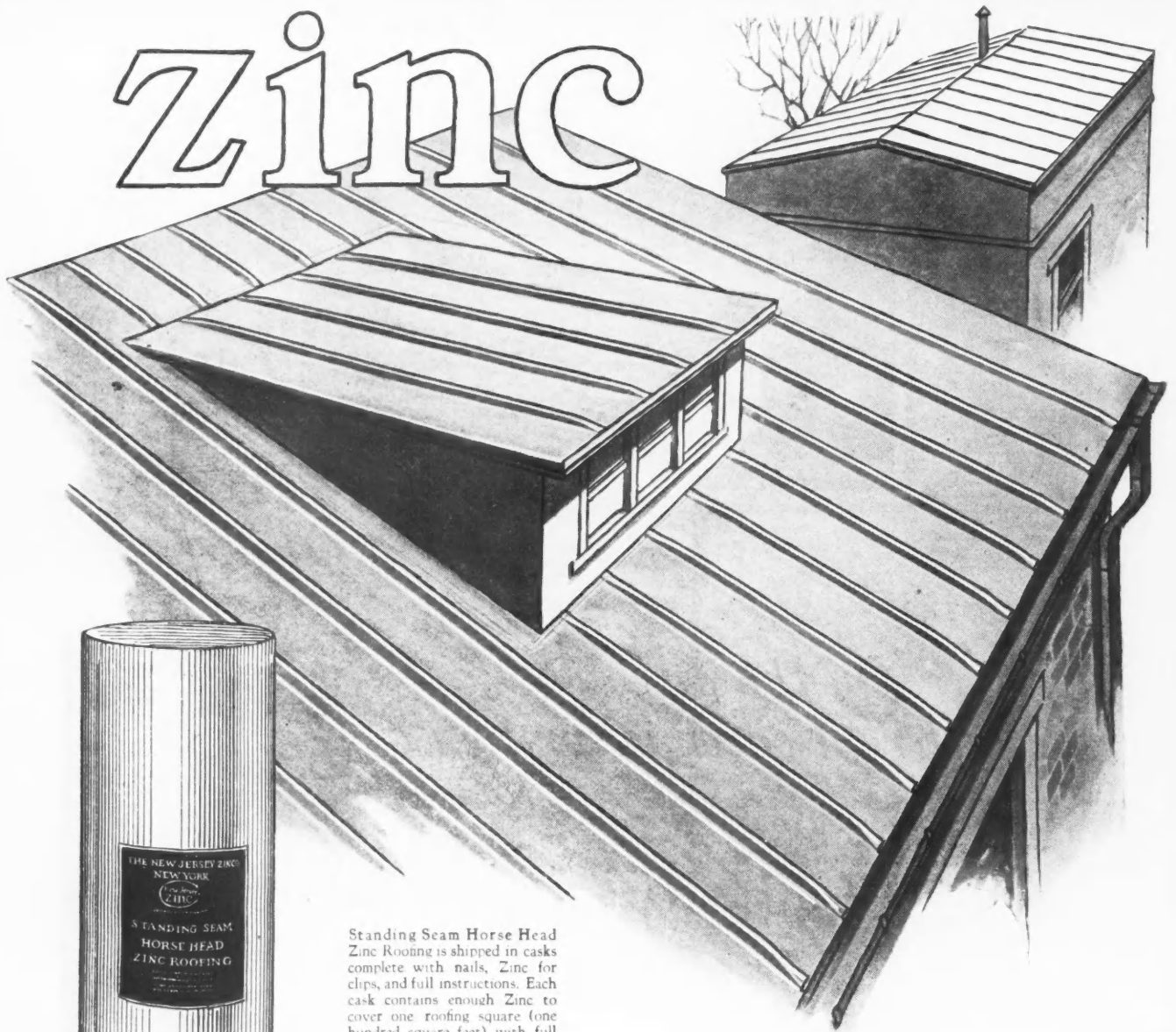

Standing Seam Horse Head Zinc Roofing is shipped in casks complete with nails, Zinc for clips, and full instructions. Each cask contains enough Zinc to cover one roofing square (one hundred square feet) with full allowances for seams and laps.

Whether it be a factory, a public building, or a house, its success as a structure depends in great measure on the permanence of the materials used. Economy of operation can only be attained by the elimination of repairs and replacements.

Standing Seam Horse Head Zinc Roofing need never be replaced. It will last as long as the building which it covers. It cannot rust—it will not leak. Zinc needs no protective coating.

Standing Seam Horse Head Zinc Roofing is the most economical metal roofing for public buildings, schools, hotels, factories, churches, farm buildings and residences.

You buy it by the hundred square feet, not by the pound. Its first cost is the only cost.



The New Jersey Zinc Company, 160 Front St., AB-3, New York

Please send me a copy of the descriptive booklet telling all about Standing Seam Horse Head Zinc Roofing.

Name \_\_\_\_\_

Address \_\_\_\_\_

**The New Jersey Zinc Company**

*Established 1848*

*Products Distributed by*

**The New Jersey Zinc Sales Company**

(INCORPORATED)

NEW YORK • CHICAGO • PITTSBURGH • CLEVELAND • SAN FRANCISCO

# \$35<sup>00</sup> Puts It On The Job And A Whole Year's Time To Pay The Balance

### What Users Say!

Hundreds of the most representative firms in all parts of the country are using our machines. Read what these have to say about the performance of the SPEED MARVEL.

#### Turner Construction Company Philadelphia, Pa.

"We have found it a most excellent outfit for miscellaneous sawing such as we have to do on our operation work. It has been in continuous use on various jobs for nearly three years, and apparently is in as good condition today as when we bought it."

#### Waterbury & Riley

84 Walker St., New York

"Your machine has done everything you said it would do, and is still in good condition after three years use. If we were in the market today, we would certainly buy the same machine. Something like thirty greenhorns have learned to use this machine without doing it any damage."

#### Geo. R. Morris Organization

Morris Bldg., Baltimore, Md.

"We find that we can cut the framing of one of our houses with one carpenter and two laborers in the same time that we formerly did the work with five carpenters."

#### The Derr Lumber Co.

6326 Market St. Philadelphia

"By using your machine for dadoing and notching our frame sills we are able to increase our production fifty percent over that which we had on the fitting-up saw."

### The Beaver Woodworker

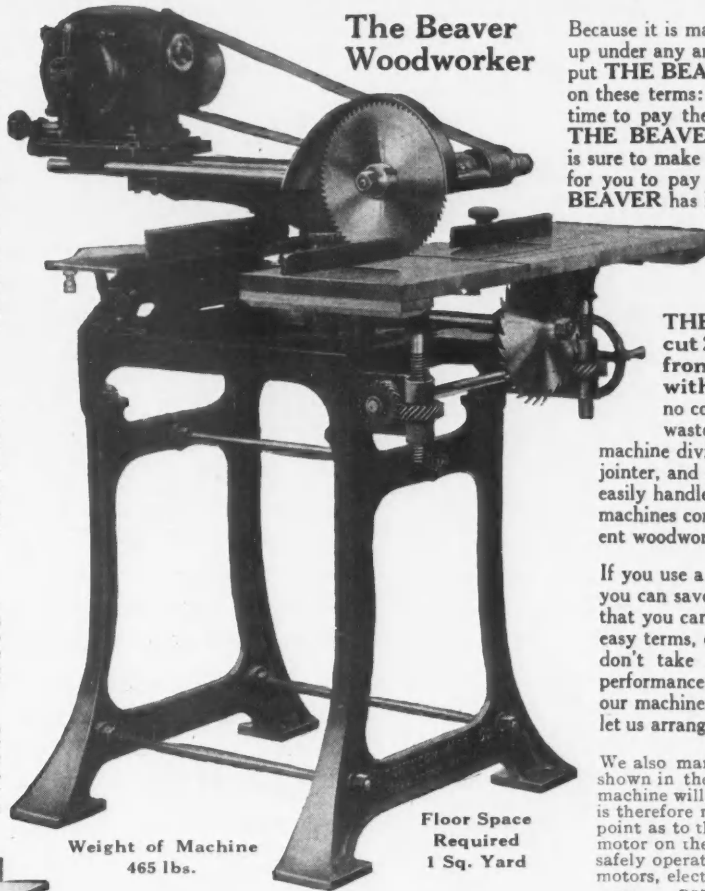

Weight of Machine  
465 lbs.

Floor Space  
Required  
1 Sq. Yard

Because it is made right, does the work, and stands up under any and all conditions, we can afford to put **THE BEAVER** Woodworker at work for you on these terms: Only \$35.00 down, and a year's time to pay the balance. We can afford to put **THE BEAVER** to work on this basis because it is sure to make money for you, and makes it easy for you to pay it. The company back of **THE BEAVER** has had more experience in the design and manufacture of portable combination light-socket woodworking machines than any other manufacturer in the world.

**THE BEAVER** will rip or cross-cut 2-inch hardwood. It operates from any electric light socket with a 1/2 H. P. Motor. There are no counter shafts and no idler pulleys to waste power. By loosening six bolts the machine divides into four parts—stand, base, jointer, and motor carriage, and one man can easily handle any part. It is practically twelve machines combined in one. Performs 23 different woodworking operations.

If you use a hand saw just one hour a day, then you can save money with the Beaver. And now that you can have **THE BEAVER** on such easy terms, don't waste time with a toy rig and don't take a machine on promise instead of performance. Read what representative users of our machines say, and then mail the coupon and let us arrange to save money for you, too.

We also manufacture **THE SPEED MARVEL**, shown in the smaller illustration below. This machine will crosscut 8-inch or rip 4-inch. There is therefore no advantage to us in stretching a point as to the capacity of **THE BEAVER**. The motor on the Beaver is the largest that can be safely operated from a light socket. For larger motors, electric light companies require special power line installation. Just tell us what your requirements are, and we'll give you sound, sensible suggestions.

### District Sales Managers Wanted!

There has been an awakening in the wood-working trades generally to the fact that the woodworking machines that are sold on performance instead of promise are those made by Hutchinson of Norristown. This is bringing us many inquiries from territory where we are not organized to handle them personally. Any carpenter can double his income with our machine, and that makes all of them prospects. If you have successfully sold typewriters, adding machines, or cash registers, we can train you to sell woodworkers. Lumber salesmen have been very successful in selling our machines as a side line, and some carpenters are making a lot of money selling woodworkers. For the right men we have a wonderful proposition.



6-inch Jointer  
with Stand



The Speed  
Marvel  
Crosscuts  
8-inch;  
Rips 4-inch

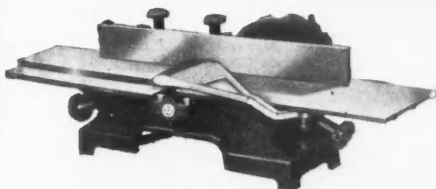

The 4-inch Bench Jointer  
with the Extra Long Table

The Jointers on the Beaver and on the Speed Marvel are very efficient, and almost the equal of separate jointers. However, we can supply you with separate jointers. We have a 4-inch bench jointer with extra long tables, and a 6-inch jointer with stand. They are unbeatable. If interested in separate jointers, just check the coupon and mail.

### MAIL COUPON FOR DETAILS

Hutchinson  
Mfg. Co.  
105 Lafayette St.  
NORRISTOWN, PA.

Please send me full particulars on the machines I have checked below.

- THE BEAVER
- THE SPEED MARVEL
- 4-INCH BENCH JOINTER
- 6-INCH JOINTER WITH STAND

NAME.....

BUSINESS.....

P. O..... STATE.....

ST. or R. D.....

## Hutchinson Manufacturing Company

105 Lafayette Street

NORRISTOWN, PA.



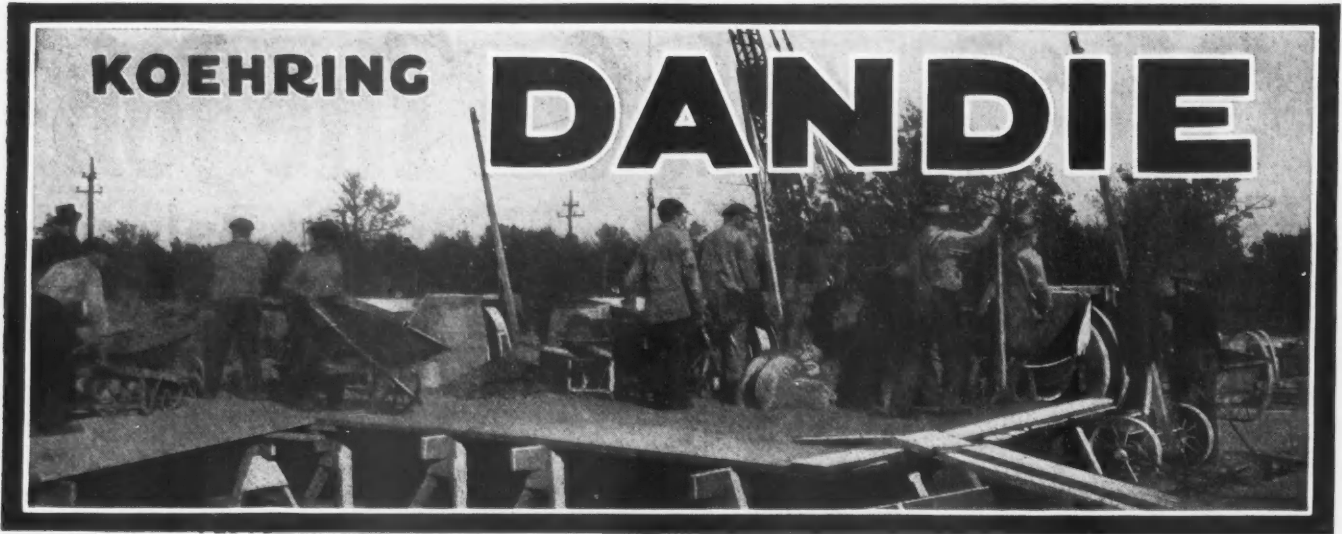

# KOEHRING DANDIE

## Send Back the Coupon!

**R**IGHT there at the bottom of this ad! The coupon will bring back to you the Dandie catalog—giving you full details of this Koehring light mixer. It's light, easily portable, but it's every inch a *Koehring*.

You'll find this catalog downright valuable to you in showing what Koehring experience, Koehring standardization, and big volume make possible in the way

of giving you a strong, no-stop, long service mixer, and still stay within the price range for light mixers. You'll discover not only that the Dandie is an extraordinary mixer, but an extraordinary, unapproached value.

What is dependability worth to you in dollars and cents? What is long service life worth? That's what it's worth to you to send back this coupon.

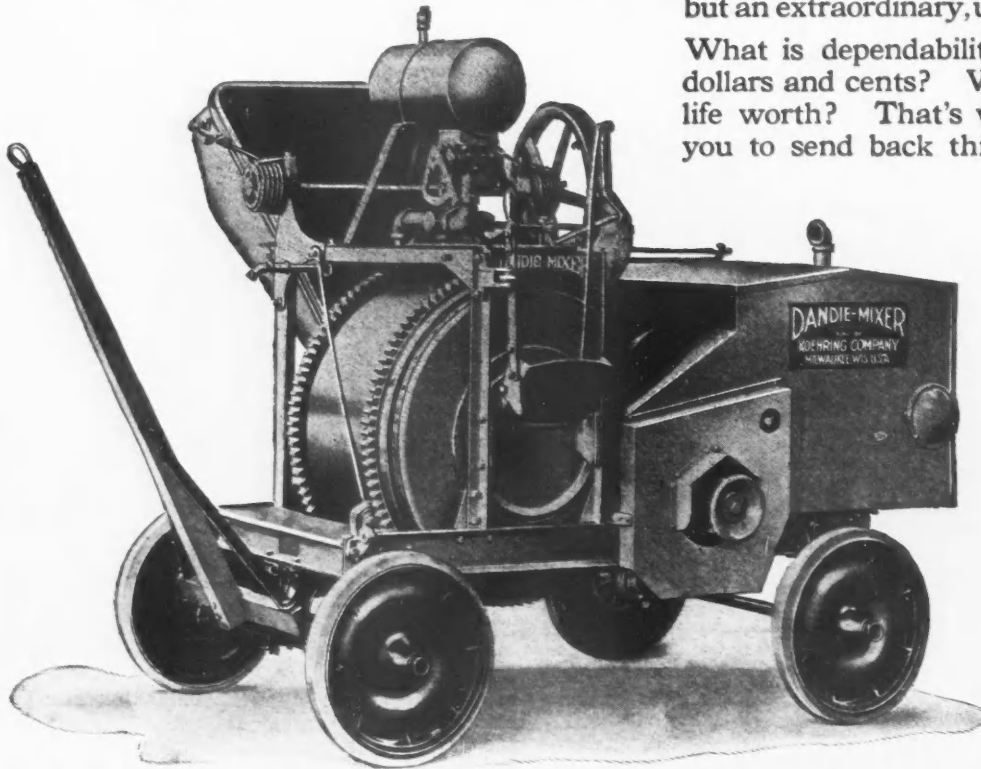

### Dandie Capacities

7 cu. ft. Mixed Concrete. Two or four cylinder gasoline engine. Power charging skip, or low charging hopper and platform. Rubber tired steel disc wheels.

### KOEHRING COMPANY

Pavers, Mixers—Gasoline Cranes, Draglines and Shovels.

MILWAUKEE, WISCONSIN

Sales Offices and Service Warehouses in all Principal Cities

Foreign Dept., Room 1370, 50 Church St., New York.

Canada, Koehring Company of Canada, Ltd., 105 Front St., East, Toronto, Ontario.

Mexico, F. S. Lapum, Cinco de Mayo 21, Mexico, D. F.

## Send Back this Coupon!

KOEHRING COMPANY, Milwaukee, Wisconsin

Please send me by return mail catalog of Koehring Dandie Light Mixer. Also price with equipment as follows:

Name \_\_\_\_\_  
Address \_\_\_\_\_

A 2259-1

11



*Boring Attachment  
and Operating Table*

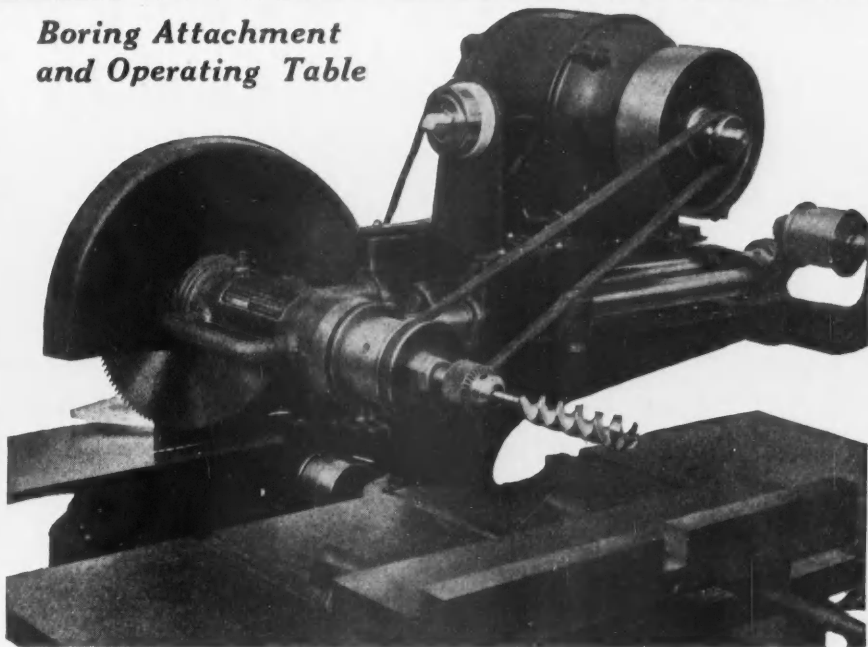

*“We finished the job way under estimated cost, and still made more money than we figured on”—*

One way to make more profit in 1925:—Don't use manual labor on work which machinery will do better and more economically. By lowering building costs the 20th Century Woodworker will bring more business for you and more work for your men. It is far cheaper to use the 20th Century Woodworker than to get along without it. Within reason, you can buy it on your own terms. Mail the coupon now and get full particulars.

*Make your jobs come out the way you figure them—or better—  
Make shorter delivery promises, and keep them—by having the*

## 20th Century Woodworker

*No Motor to Pull*

In crosscutting with the 20th Century Woodworker the operator pulls the saw only, the motor remaining stationary. This saves effort for the operator, reduces vibration, and makes for more accurate work.

With a 10-inch saw and a 1 H. P. Motor the 20th Century Woodworker will rip or cross-cut 3-inch hardwood. With a 12-inch saw and 1½ H. P. motor it will rip or crosscut 4-inch hardwood.



**Ball-Bearing Construction**

*Mail Coupon for Details* →

**Cresson-Morris Co.**

18th Street &  
Allegheny Avenue  
Philadelphia  
Pa.

The 5-in. Jointer on the 20th Century Woodworker in workmanship and finish is the equal of any separate jointer.

Cresson-Morris Company  
Allegheny Ave. & 18th St., Philadelphia  
Please send full particulars on the 20th Century Woodworker

Name .....

Line of Business .....

P. O. ....

St. or R. D. ....

State .....

# PREMIER GAS WATER HEATERS

*Home builders and buyers appreciate the comfort and convenience of Instant Hot Water*

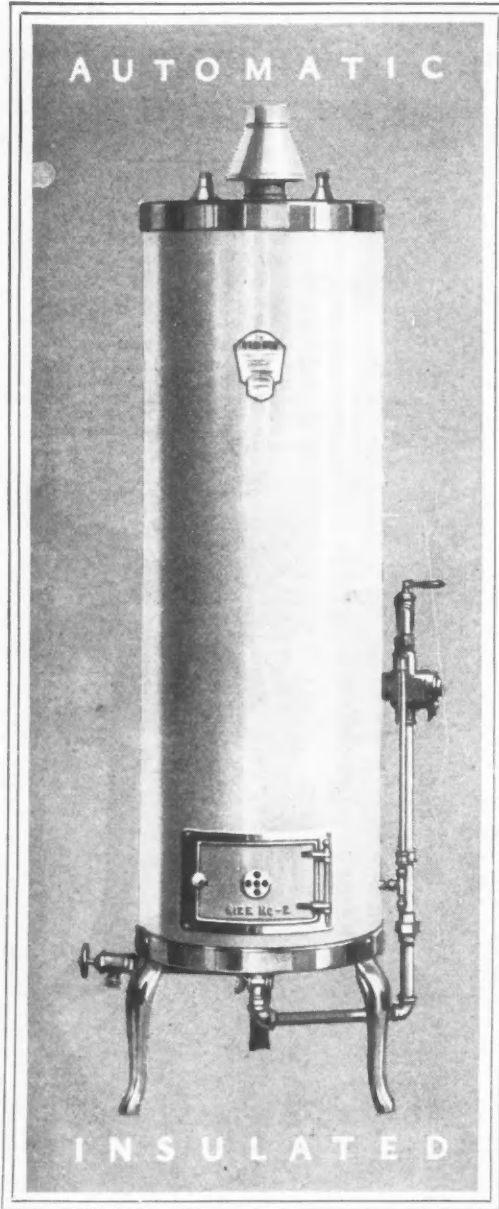

RECOGNIZED by home builders and buyers as essential both to health and comfortable living, instant hot water is made practical and economical by the Premier storage-type water heater.

The Premier is automatic, dependable, thrifty. Built in four different sizes to meet various home needs, it is priced to fit any building or remodeling budget.

Here are some reasons why the Premier is the most satisfactory gas water heater made for domestic or shop use:

*Instant Hot Water* is delivered, piping hot, at any faucet, night or day—a quart or a tubful, from the stored supply.

*Simplicity* marks Premier construction. A single blue-flame burner. No complicated moving parts to get out of order. No coils to “lime up,” waste fuel and require expensive removal for cleaning and ultimate replacement.

*Durability* insures a long life of trouble-free service. The tank is of double extra heavy construction, heavily galvanized. The heating element, thermostat and valves are sturdy in design and dependable in operation.

*Economy.* It saves gas because it starts and stops itself. Its burner is lighted only when more hot water is needed. The Thermoseal insulation covering tank locks in the heat like a giant “Thermos” bottle. Its outer steel jacket is finished in Premier gray enamel with nickel trim.

*Four thrifty sizes. Premier No. 2, \$125 at factory, the right size for average home*

*The Premier Automatic Water Heater can be obtained promptly from established plumbing contractors*

# CRANE

*Address all inquiries to Crane Co., Chicago*

GENERAL OFFICES: CRANE BUILDING, 836 S. MICHIGAN AVENUE, CHICAGO

*Branches and Sales Offices in One Hundred and Forty-eight Cities*

*National Exhibit Rooms: Chicago, New York, Atlantic City and San Francisco*

*Works: Chicago, Bridgeport, Birmingham, Chattanooga and Trenton*

CRANE EXPORT CORPORATION: NEW YORK, SAN FRANCISCO, SHANGHAI  
CRANE LIMITED, CRANE BUILDINGS, 386 BEAVER HALL SQUARE, MONTREAL

CRANE-BENNETT, LTD., LONDON

CIE CRANE: PARIS, NANTES, BRUSSELS

# Nelson

MASTER • SLAB • ROOFS

A builder's taste and individuality are truly expressed in a Nelson Master Slab Roof. With its warm colors he adds cheer and coziness to the simple little cottage. The great mansion he dignifies and strengthens with a cooler blend.

Whatever the type of building, there is a Master Slab Roof which will not only beautify but protect it for years to come. May we show you the proof?

The B. F. Nelson Manufacturing Co.  
Minneapolis, Minn.

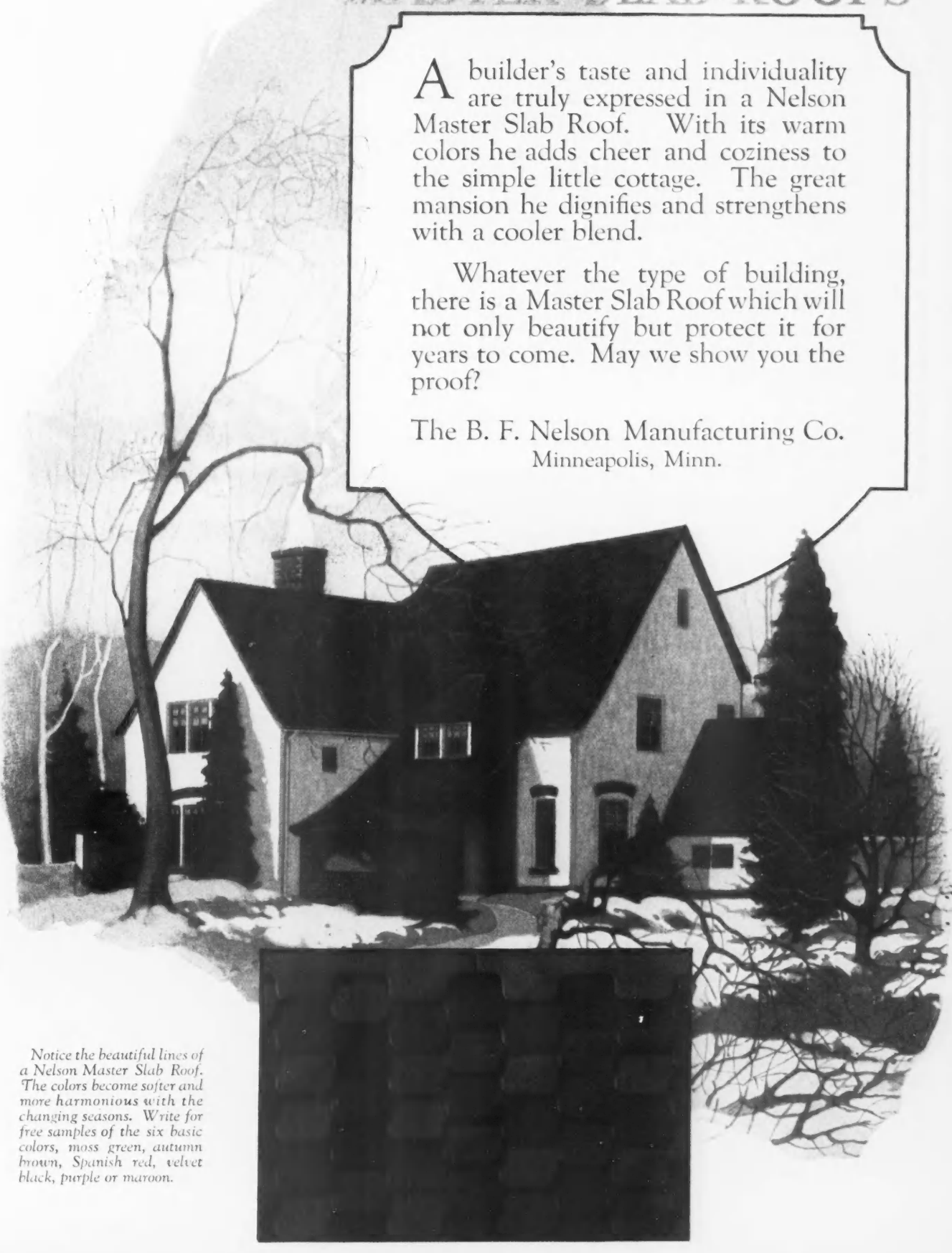

*Notice the beautiful lines of a Nelson Master Slab Roof. The colors become softer and more harmonious with the changing seasons. Write for free samples of the six basic colors, moss green, autumn brown, Spanish red, velvet black, purple or maroon.*

# HOW TO ADVERTISE BUILDING SUPPLIES

The advertising of building supplies presents a greater problem than that of any other merchandise because there are so many different groups which influence the sale.

Other merchandise usually goes from the maker to the jobber, to the dealer, to the consumer and at each step a purchase is made. But with building supplies one must first persuade architects and contractors together with a half dozen more groups before he can always be certain his merchandise will flow through the channels of distribution.

The combined circulation of the five publications in which our clients are using color advertising reaches the leaders in the following groups:

Architects and Engineers	Manufacturers and Industrial Users
Building Supply Dealers	Prospective Owners
Contractors and Builders	Realtors
Draftsmen	Students
Interior Decorators	Wholesalers
Libraries, Colleges and Schools	

By advertising to the leaders in these different groups and using full color once each month, our clients are making the maximum impression on the entire field at the minimum expense.

**MAC MARTIN ADVERTISING AGENCY**

*Security Building, Minneapolis*



There's a saving of time in getting Andersen Frames, too. Any Andersen dealer can deliver 121 different sizes right from stock, whenever the builder wants them.

Write for latest information on Andersen Standard Frames, stating whether you are an architect, contractor, dealer or prospective home owner.



Look for this trade mark—it appears on every Andersen Frame.



## *Ten minutes and the frames up*

Any amateur can put up an Andersen Frame in fifteen minutes. Donald MacKinnon, Contractor, 91 Adelaide St., Belleville, N. J., writes that Andersen Genuine White Pine Frames "Can't be beat—Put together in seven minutes." The seven units are so accurate that no tinkering is necessary. On a twenty-frame house this saving of time and labor counts up.

Andersen Lumber Company  
Bayport, Minnesota

# *Andersen* **FRAMES**

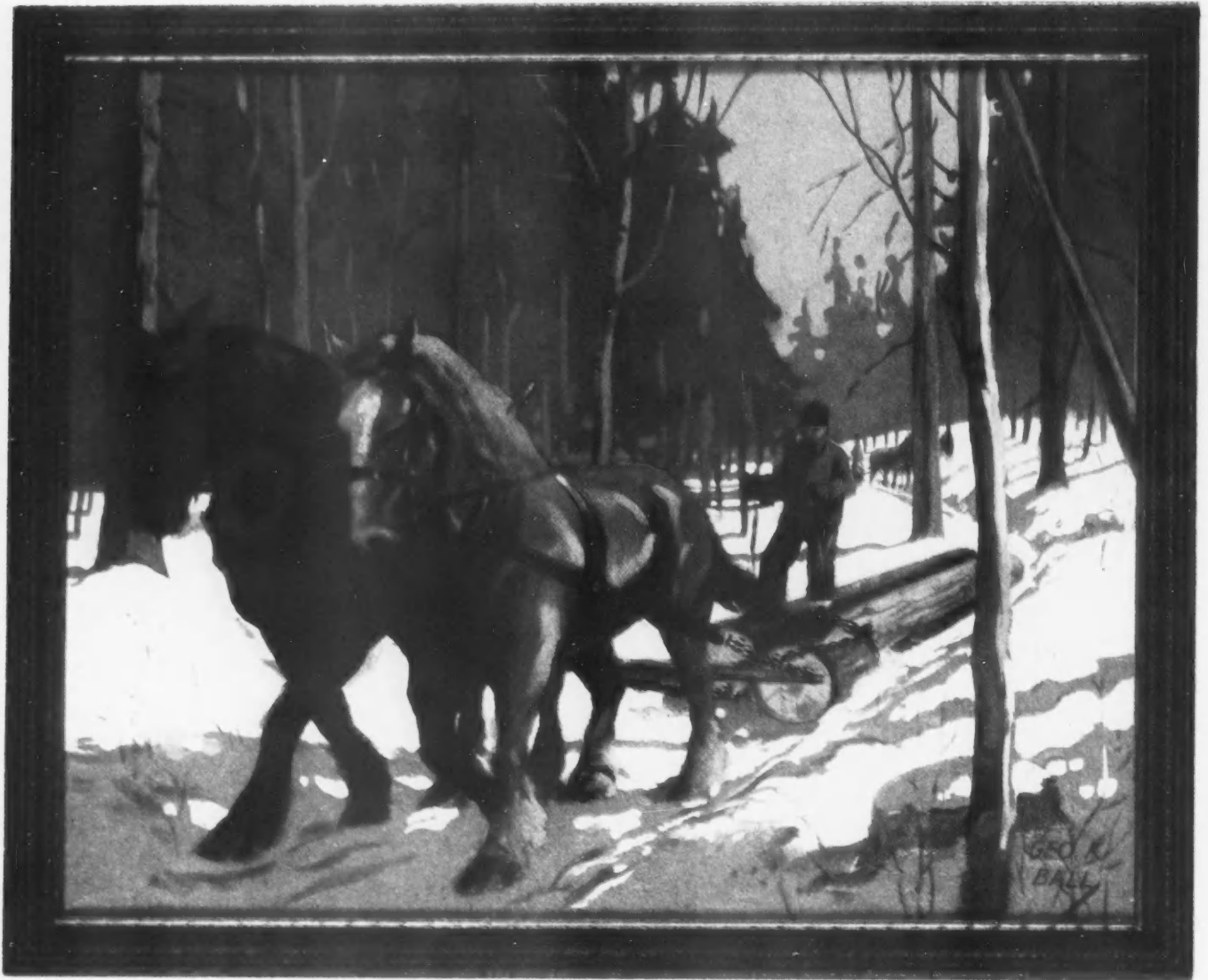

❧ "Snaking the Logs" ❧

**T**HE first move of the giants of the forest after they have measured up to Shevlin standards is known as "Snaking the logs." ❧ Every winter scores of such teams are dragging Shevlin logs over the rough, snow covered roads in preparation for the next season of building. ❧ Each step brings pine of Shevlin quality that much nearer to you and your needs.

Shevlin, Carpenter & Clarke Company

900 First National Soo Line Bldg., Minneapolis, Minn.



# What Is Good Insulation?

**Y**OU certainly know that wool, curled hair, cotton batting, eider down and feathers are about the best heat insulators. All of them **light in weight** yet big in bulk. It isn't the weight or the density that makes good insulation. The good insulators—all of them—have as the foundation of excellence **dead air**. And dead air is good because it can neither receive nor communicate heat by radiation.

Now when building a house, it has been customary to make the interior walls of plaster for two reasons; first, to give a solid background for decoration, and, second, for sound and heat insulation. It may not be generally known, but usually a sound-proof room is well heat-insulated.

"Cornell" has been used quite extensively instead of plaster and lath for walls and ceilings because it possesses both the necessary requirements; in fact, "Cornell" has an outstanding virtue as an insulator of heat and sound.

The reason of this is, that while both "Cornell" and "Super Cornell" have sufficient rigidity as a wall covering, they are lighter in weight and therefore possess a much greater insulation value than heavier and more rigid boards.

Remember, please, that neither weight nor stiffness (by themselves) add to the value of a wall covering in so far as heat insulation is concerned. This is a scientific statement well worth remembering. The millions of dead air cells in each square foot of "Cornell" is your safest insurance that if laid properly on walls it will **keep rooms warm** in winter and cool in summer.

"Cornell" in any quantity and in all sizes is quickly available for hurried jobs, large or small, through our distributors. Cornell dealers everywhere are always near these sources of supply.

As "Cornell" is made wholly of wood and built to a standard and not down to a price, its quality is constant and reliable.

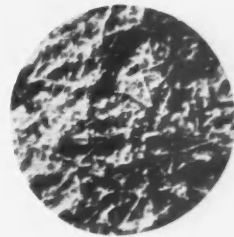

Dead air is the best insulator known. The meshing of Cornell Wood fibres produces innumerable dead air pockets as are shown in this microscopic photograph, enlarged 15 diameters. Insulation means so much that we stress this point. Cornell is purposely made to give the absolute maximum of insulation. Boards of dense construction like plaster or pressed paper lack sufficient dead air cells to assure this most important requisite.

## CORNELL WOOD PRODUCTS CO.

190 N. State St. Chicago

Mills: Cornell, Wisconsin



**Cut Out Coupon and Mail Today**  
 Cornell Wood Products Co., 190 N. State St., Chicago

Please send samples of

"Cornell"       "Super Cornell"

Name .....  
 Address .....

AB-3

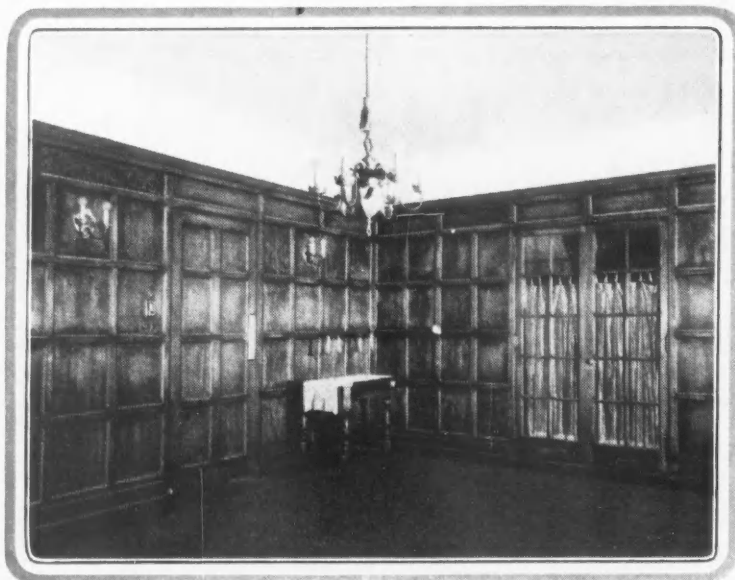

## There is true economy in CURTIS WOODWORK

**H**ERE is another example of the practicability of Curtis Woodwork for builders and contractors. Every item in this attractive entrance hall was made by Curtis. And this is just one of the endless opportunities for distinctive interiors which Curtis Woodwork makes possible.

Curtis designs are known wherever better homes are built. Curtis craftsmanship is a recognized factor among builders and contractors who take pride in the homes they build. But, best of all, Curtis methods and their large producing facilities make it possible for you to give your customers far greater advantages than they would get from ordinary "millwork." And at a lower final cost, too.

Let the nearby dealer show you the wide variety of designs and styles from which you may choose your entrances, doors, windows, interior and exterior molding—as well as the numerous items of built-in features. He can also show you how greatly Curtis Woodwork will add to the value of your homes.

### THE CURTIS COMPANIES SERVICE BUREAU

370 Curtis Building, Clinton, Iowa

Curtis Bros. & Co., Clinton, Iowa; Curtis & Yale Co., Wausau, Wis.; Curtis, Towle & Paine Co., Lincoln, Nebr.; Curtis, Towle & Paine Co., Topeka, Kan.; Curtis-Yale-Holland Co., Minneapolis, Minn.; Curtis Door & Sash Co., Chicago, Ill.; Curtis Sash & Door Co., Sioux City, Iowa; Curtis Detroit Co., Detroit, Mich.

Curtis Companies Incorporated, Clinton, Iowa

Sales Offices in: Pittsburgh, New York, Baltimore

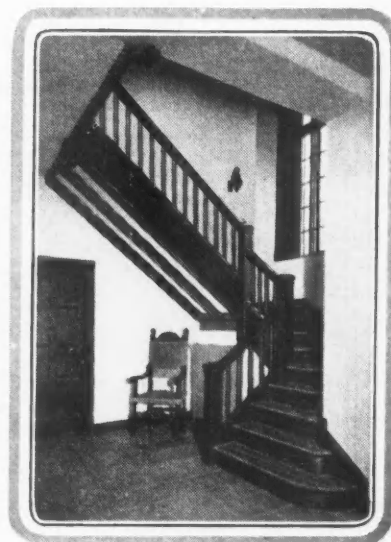

**Curtis Stair—C-912**

An example of the true economy of Curtis Woodwork is illustrated here. The savings in cost for stair parts alone is well worth considering. For instance, a stair volute, most intricate from the manufacturing standpoint, is priced at less than half the cost of but a few years ago. Other items are equally as reasonable.

**1866  
CURTIS**

Curtis Woodwork is identified by the mark above. Whatever you buy—sash, door, molding, or interior woodwork—see that it bears this trademark. Curtis Woodwork is sold under the "1866 Curtis trademark" by Curtis dealers east of the Rockies.



# ATKINS

## SILVER STEEL SAWS

### A He-Man's Saw

The Four Hundred Saw pictured on this page is in demand by master carpenters and artisans who want something above the average in quality and finish.



### Are You Using This Saw?

The finest saw ever made. Manufactured from Silver Steel, Atkins' exclusive formula. Tempered perfectly to insure long-wearing and sharp cutting teeth. Furnished in regular pattern, skew back; ship pattern, straight back. Ship pattern saws are made in 26 inch lengths only. Ground to a full four gauge taper, and will cut fast and easy with very little set. Mirror polish with Improved Perfection Rosewood Handle, the handle that prevents wrist strain.

Order one from your hardware dealer and find out for yourself that it is

### "The Finest on Earth"

In 26 inch length, price \$5.65 east of the Rockies.  
Price slightly higher west of the Rockies.

## E. C. ATKINS & COMPANY

Established 1857

Machine Knife Factory:  
Lancaster, N. Y.

HOME OFFICE AND FACTORY:  
INDIANAPOLIS, IND.

The Silver Steel Saw People  
Canadian Factory:  
Hamilton, Ont.

BRANCH HOUSES

Atlanta      Chicago      Memphis      New Orleans      New York  
Portland      San Francisco      Seattle      Vancouver, B. C.      Paris, France



Residence in White Plains, N. Y.

Donn Barber, Architect, New York City

**E**NTRANCES made by Hartmann-Sanders are famous for lasting beauty, perfection of materials and architectural correctness.

Let us serve you. We have been specializing in Colonial Entrances for 25 years. We manufacture entrances complete from your own specifications and deliver ready to erect; or you can select your own model designs. In all entrances, we use Koll Columns, the kind that cannot come apart.

Our new catalog, Y51, illustrates 24 beautiful Colonial Entrances. Write for copy. Address Hartmann-Sanders Co., 2187 Elston Avenue, Chicago, Ill. Showroom: 6 E. 39th Street, New York City.

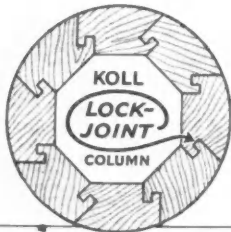

**THEY CANNOT COME APART**

**HARTMANN-SANDERS**  
KOLL LOCK-JOINT COLUMNS  
COLONIAL ENTRANCES

# WHAT DOES FIREPLACE SUCCESS DEPEND UPON?

## *Proportioning the fireplace opening—*

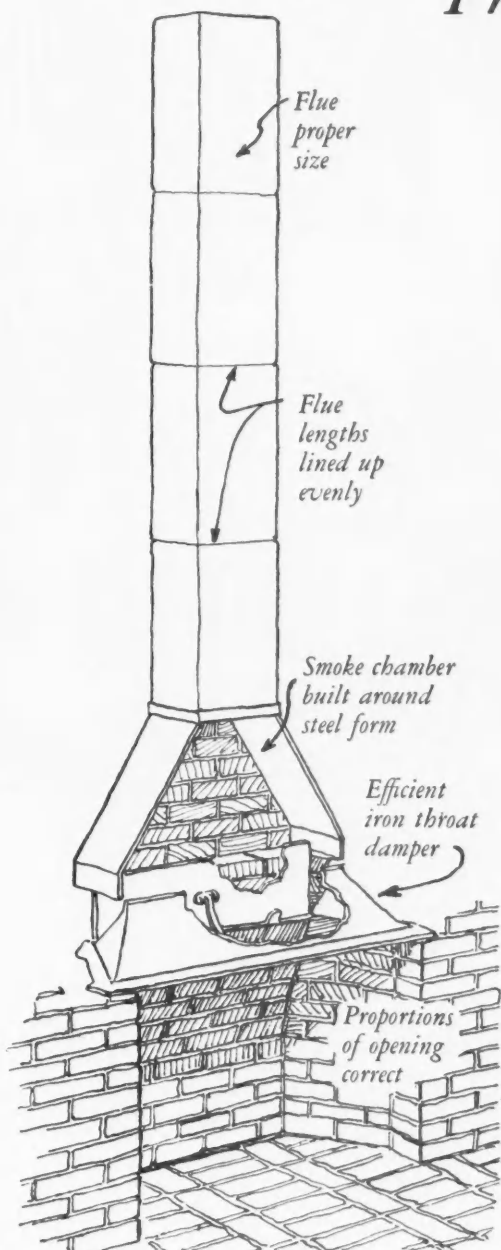

THE opening of the fireplace has a great deal to do with the actual amount of heat which is thrown out into the room, as well as the efficient working of the fireplace.

If the fireplace is too deep, the sides will cut off considerable heat radiation, and if too shallow, the smoke is likely to find its way out into the room.

After extensive experimenting it has been determined that a depth of 18 inches at the hearth is ample in fireplaces up to 48 inches in width, and 20 to 24 inches for wider fireplaces.

Splayed sides make the back of the fireplace narrower than the front and give the fireplace the shape of a reflector, thereby throwing out into the room a maximum of heat. This splay should be about 5 inches to the foot.

The height of a fireplace should not be greater than the width, and 30 inches is ample for fireplaces up to 48 inches wide. For higher fireplaces 32 to 34 inches is sufficient. When the architecture of a room demands that the height of a fireplace be greater than the width it is best to get in touch with the H. W. Covert Company and have a plan drawn up by our service department.

Curving the back of a fireplace should be avoided, as this is likely to throw the smoke out into the room. It is safer to run the brickwork up straight three courses and then slant the back forward in a straight line to meet the rear of the damper.

*This is the first of a series on "Successful Fireplaces," and if you will send us your name and address we shall gladly forward to you a complete set of the series*

**The H. W. COVERT COMPANY, 137 East 46th Street, New York City**



QUALITY LEAVES



ITS IMPRINT

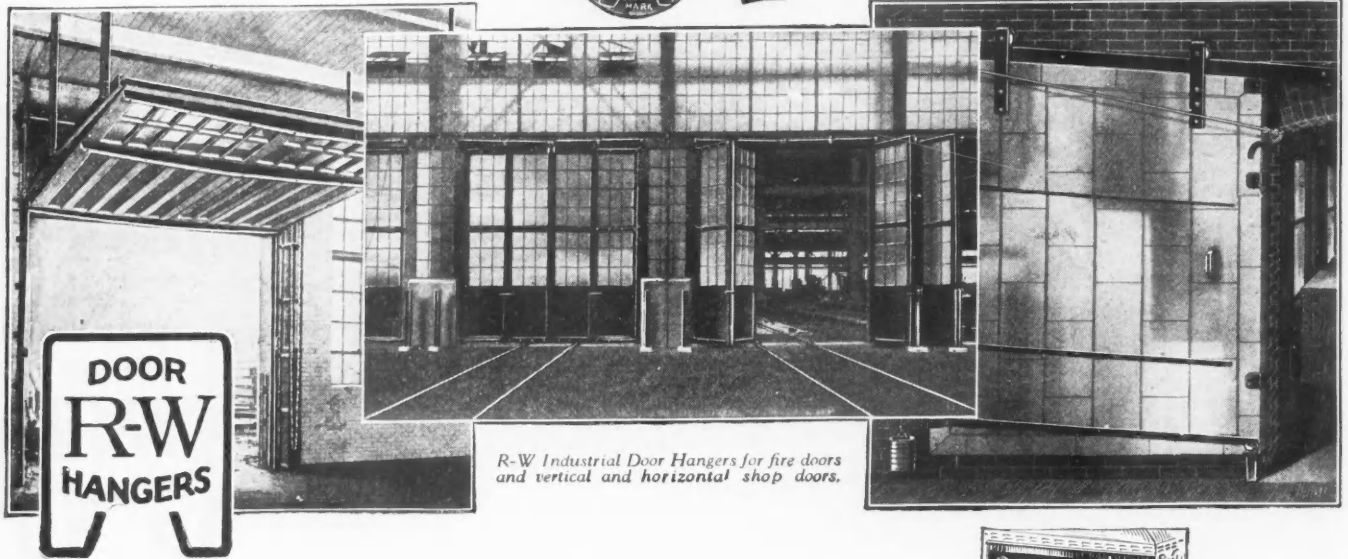

DOOR  
R-W  
HANGERS

R-W Industrial Door Hangers for fire doors and vertical and horizontal shop doors.

## A Hanger for Every Door that Slides!

There is an R-W Door Hanger suitable for every door that slides—from great round house and car shop doors, large enough to admit a locomotive or box car, down to the light sliding doors of show cases and pantries. We are America's foremost makers of door hangers for elevators, for factories, for warehouses and pier sheds, for garages, for barns and for use in the home.

Every R-W Door Hanger is made with painstaking care to give a lifetime of care-free service. In fact, the extreme durability, ease of operation and permanence of adjustment of R-W Door Hangers has long since made them standard equipment of their kind.

No matter how puzzling your door hanging problem may be, don't hesitate to put it up to this famous organization of door hanger specialists. We'll quickly supply the solution. Write to Department G for particulars of this free service, as well as for literature describing the complete line of R-W Door Hangers.

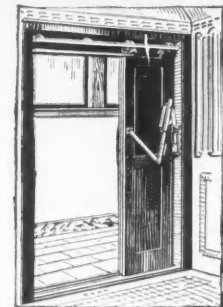

R-W IDEAL Elevator Door Hardware for silent, safe and speedy service.

R-W Barn Door Hangers for durability and ease of operation in all weathers.

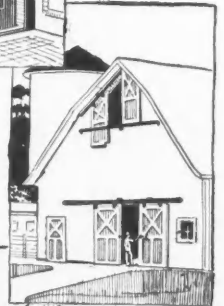

SLIDETITE equipped garage doors slide, away from the wind, ice and snow.

R-W Vanishing Door Hardware for the modern home.



New York  
Boston  
Philadelphia  
Cleveland  
Cincinnati  
Indianapolis  
St. Louis

# Richards-Wilcox Mfg. Co.

A Hanger for any Door that Slides.

AURORA, ILLINOIS, U.S.A.

RICHARDS-WILCOX CANADIAN CO., LTD.  
Winnipeg LONDON, ONT. Montreal

Chicago  
Minneapolis  
Omaha  
Kansas City  
Los Angeles  
San Francisco  
Seattle

(823)



# CARNEY

*for Brick and Tile Mortar*

## The Strength of Carney

**T**WO years ago Carney was specified and used for laying up the brick, tile and terra cotta in the first great section of the Wrigley Building, Chicago.

When making the openings in the old section for joining the new North Section recently completed, it was found the Carney mortar had so hardened and the bond was so strong it was necessary to crush the brick.

Such a convincing and striking proof of the strength and quality of Carney naturally induced the builders of the new North Section to specify and use it again in that structure.

So the entire Wrigley Building stands completed today a lasting monument to the strength, durability and economy of Carney.

*Carney is the perfected cement for brick and tile mortar.*

### The Carney Company

*Cement Makers Since 1883*

**Mankato, Minn. Mills at Mankato, Carney, Minn.**

**District Sales Offices:** Leader-News Building, Cleveland; Chamber of Commerce Building, Chicago; Omaha National Bank Bldg., Omaha; Syndicate Trust Building, St. Louis; Book Building, Detroit; Builders' Exchange, Minneapolis.

*Specifications: 1 part Carney to 4 parts sand.*



**WRIGLEY BUILDING, CHICAGO, ILL.**

*Architects: Graham, Anderson, Probst & White, Chicago, Ill.  
Contractor: Lanquist & Illsley Co., Chicago, Ill.*

Everyone can visualize the many advantages of a sturdy, short, compact chassis for business:

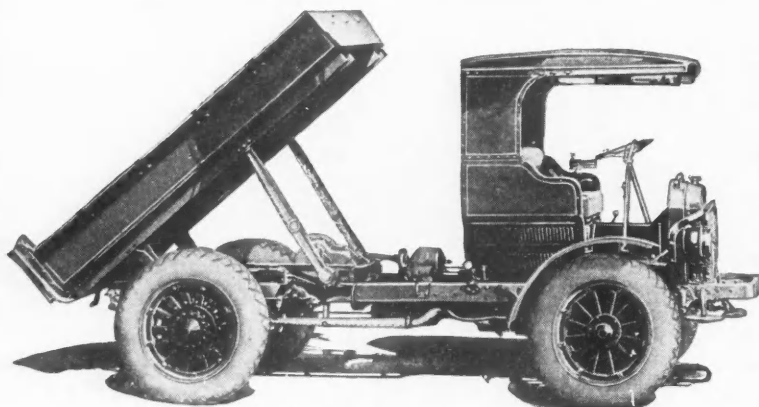

The Contractor's Special 3-Ton Autocar gas dump truck

- Short turning radius
- Time saved everywhere
- Street space conserved
- Traffic congestion reduced
- Load evenly distributed
- More space for pay load
- Extraordinary durability

A complete line of Autocar gas and electric trucks  
Capacities 1 to 5 tons  
Send for our descriptive detailed book—  
Either gas or electric

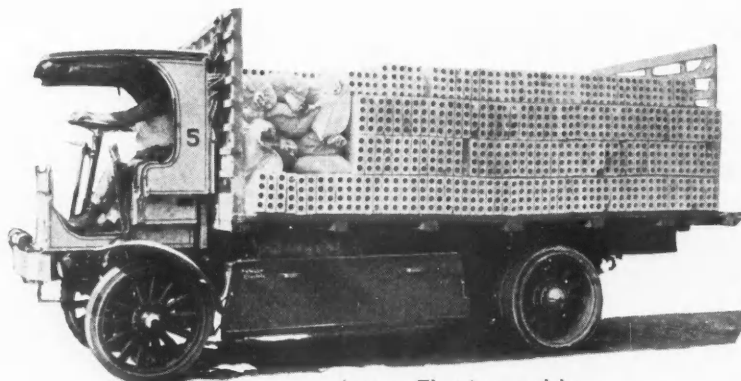

Autocar Electric owned by H. W. Bell Co. of New York

## The Autocar Company, Ardmore, Pa.

ESTABLISHED 1897

Direct Factory "Autocar Sales and Service" Branches or Affiliated Representatives in

- |                 |             |                |               |                |                 |                 |
|-----------------|-------------|----------------|---------------|----------------|-----------------|-----------------|
| * Albany        | * Brooklyn  | * Detroit      | * Los Angeles | * Orlando      | * San Francisco | Trenton         |
| * Allentown     | * Buffalo   | * Erie         | * Memphis     | * Paterson     | * San Jose      | * Washington    |
| * Altoona       | * Camden    | * Fall River   | * Miami       | * Philadelphia | * Schenectady   | West Palm Beach |
| * Atlanta       | * Chester   | * Fresno       | * Newark      | * Pittsburgh   | Scranton        | * Wheeling      |
| * Atlantic City | * Chicago   | * Harrisburg   | * New Bedford | * Providence   | Shamokin        | Wilkes-Barre    |
| * Baltimore     | * Cleveland | * Indianapolis | * New Haven   | * Reading      | * Springfield   | Williamsport    |
| * Binghamton    | * Columbus  | * Jersey City  | * New York    | * Richmond     | * St. Louis     | * Wilmington    |
| * Boston        | * Dallas    | * Lancaster    | * Norfolk     | * Sacramento   | * Stockton      | * Worcester     |
| * Bronx         | * Denver    | * Lawrence     | * Oakland     | * San Diego    | * Syracuse      | York            |

\* Indicates Direct Factory Branch

# Autocar

gas and electric trucks

EITHER OR BOTH - AS YOUR WORK REQUIRES

# AROUND THE FAMILY TABLE

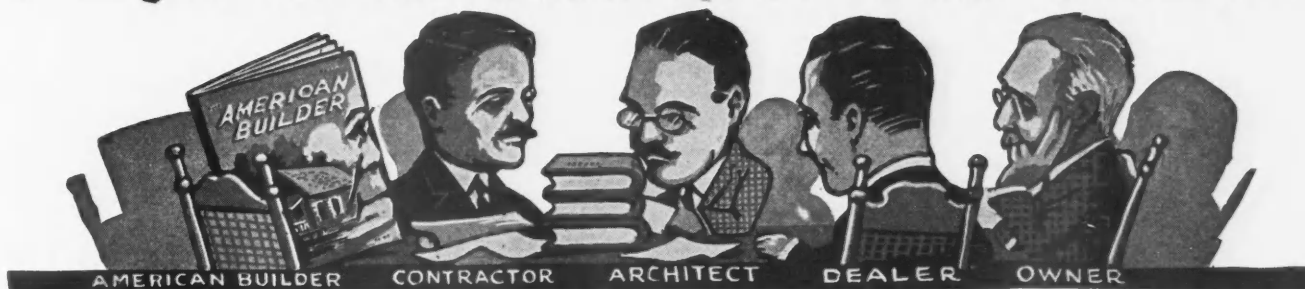

## We Yield to Your Wishes

And Change Date of 1925 Annual from April to June

SINCE making the announcement last month on this page that April had been picked for this year's Annual Reference Number, similar to the Big June Number of last year, we have been deluged with many letters of protest. Both subscribers and advertisers seem to prefer the June date of issue, the same as last year.

We are accordingly postponing two months the Big Reference Number for 1925 and will issue it as our Big June Number, the same as heretofore.

We are very glad to yield to the wishes of the majority in this matter.

Several facts have been pointed out since the announcement of last month which are really important and should control the date of issue of the Annual Number.

*In the first place*, the 1924 Annual of last June is still in active use in thousands of offices where it is being referred to constantly as a book of reference and a buyers' guide. It would be unfair to this great book to cut short in any way its effective life. It should have—our friends and advisors have pointed out—a full twelve months, June to June, without interference from any other similar volume.

The reference data in the 1924 Annual, and, in fact, in every issue of the AMERICAN BUILDER is of permanent value and does not go out of date. We know personally of hundreds of instances where copies of the AMERICAN BUILDER five and ten years old are still in active use.

Nevertheless there is always the tendency to use the most recent issue of the AMERICAN BUILDER in preference to an older one. So the general feeling seems to be that the Big June Issue of 1924 should have its full year of first choice circulation and use.

*Then, furthermore*, it has been pointed out that June is the most desirable date of issue from a business building point of view. The spring building activity is always assured. There is never any question about the building industry having all it can possibly do in

April and the other spring months. However, along in the summer sometimes the work falls off and a mid-summer dullness develops. A magazine of unusual interest, size and importance issued in June will go a long way to stimulate building activity and keep things going.

If our readers will use this New Big June Issue of this year the same as they did last to go out and interest prospective owners, there will be no let-up in building activity throughout 1925.

The monthly records of building activity last year show a remarkable steadiness of volume right through the summer and into the fall and winter building seasons. This fine record has been largely attributed to the effective work which was done by our outstanding June Issue of last year in the hands of the 85,000 active and aggressive men of the building industry who made such effective use of it all through the year.

### Accordingly the 1925 Annual Number Will Be Issued June 1st.

It will be a book of more than six hundred pages, bound in special strength covers for long life and beautifully lithographed in four colors and gold. Our artists have produced a painting which surpasses that of last June in human appeal, strength and attractiveness. Our editors, architects and special writers are at work on additional features that will add greatly to the value of this 1925 Annual Number.

Printing orders have been placed for 85,000 copies, but it begins to look as though this would not be enough and the edition may have to be still further enlarged. We do not want any of our friends to be disappointed in getting their June magazine, so if you are on the regular mailing list make sure that your subscription is fully paid up to include June, or if you are in the habit of buying the AMERICAN BUILDER on the news-stand, better place your order now and have the news dealer lay your copy aside for you, as at only 35c each these big books will very soon be snapped up, and the dealers will have only a very limited supply.

You will notice from the statement on the front cover this month that the AMERICAN BUILDER circulation is steadily growing. We are up to 82,000 now. Considering this, the 85,000 planned for June will scarcely be enough. Better write and tell us if you think we will need more, and we will wire the mill to ship us a few more carloads of paper.

EDITOR AMERICAN BUILDER.



Res. of James Gilmore, Esq., Res. Arch. Cincinnati, Ohio, Bishopric Ivory Cream Stucco over Bishopric Base on all exteriors.

### Stucco walls of greater strength

Ordinary Stucco      Bishopric Stucco



The enormous tensile strength of Bishopric Stucco is illustrated here. This is just one of the Bishopric guarantees of permanence on the wall.

# How Bishopric provides lasting beauty and protection

Rare beauty of shade and texture, with permanent protection from the elements are exclusive Bishopric qualities that are being appreciated more and more by those interested in home-building. BISHOPRIC is a super-stucco with greatly increased strength, thus providing durability and protection so vital to every building, whether it be large or small. In Bishopric only can be obtained the wide variety of beautiful shades and textures now demanded by those who appreciate the best. With Bishopric, beauty and protection go hand in hand.

Tensile strength tests show BISHOPRIC far superior to other stuccoes.

BISHOPRIC is fireproof, magnesia rock used is the same as that used to line furnaces and smelters — Tremendous heat has no effect on it.

BISHOPRIC is thoroughly waterproofed by a secret process shutting out moisture, cold, heat, wind and vermin.

BISHOPRIC Insulation Qualities are practically perfect, retarding heat and cold, eliminating objectional noises.

BISHOPRIC requires no painting or renewing — A wall built to stand for generations.

In mansion or bungalow, Bishopric Stucco has a place, whether laid over stately lines or designed after those quaint cottage effects, now so popular.

Bishopric Stucco endures in every clime, retaining its strength and its original color in temperatures of either extreme. Economical in original cost, negligible in upkeep, warm in winter and cool in summer, BISHOPRIC STUCCO over BISHOPRIC BASE not only wins friends but keeps them. And no wonder, for it yields itself to any form and endures from generation unto generation.

An interesting booklet "Bishopric For All Time and Clime," illustrated with photographs of beautiful houses built with Bishopric Stucco, plaster and sheathing units will be mailed you Free.

*Bishopric is Sold by Dealers Everywhere*

The BISHOPRIC MANUFACTURING CO  
 5 ESTE AVE. CINCINNATI, OHIO  
NEW YORK CITY      CHICAGO, ILL.      OTTAWA, CANADA  
 BISHOPRIC MFG CO OF CALIFORNIA  
LOS ANGELES

Ordinary Stucco

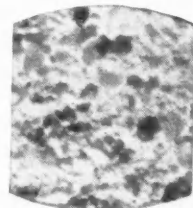

The average stucco being marketed today is extremely porous and therefore NOT WATER-PROOF. Notice the spongy porous formation in this enlargement and compare the density of Bishopric shown below.

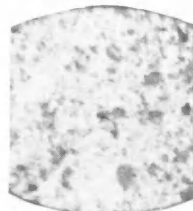

Bishopric Stucco

## BISHOPRIC STUCCO *over* BISHOPRIC BASE

*"A Complete Wall Unit for all Time and Clime"*



# Are Easier Payments Desirable in Building Field?

**S**ALES of luxuries, such as automobiles, pianos, phonographs, furs, jewelry, radio and many others, have been enormously stimulated by deferred payment plans. It is a matter of record that over four million automobiles were sold during 1923 and 90 per cent of the trucks, as well as 75 per cent of the passenger cars, were sold on easy payments. This represents installment credits of at least \$1,500,000,000, handled by some 635 financing companies.

Radio is, perhaps, the latest entry in this field and a well known statistical bureau estimates that radio sales, during 1924, will reach a total of \$300,000,000—a large proportion of it sold on the installment plan. This proportion is likely to increase during 1925.

## Should More Credit Go to Necessities

Economists are now asking—would it not be sounder finance to have a larger share of installment credit for necessities rather than for luxuries? We are not overlooking the fact that the easy payment have been popular in the sale of a long list of commodities which might be classed as necessities, such as clothing, furniture, sewing machines, etc. The question is worth asking, however, would not the public receive greater benefit if a larger share of capital was made available for financing the sale of new buildings, renewals, additions and repairs on easy payments?

Likewise, in the matter of extensions, renewals and repairs—a great deal of painting, stuccoing, shingling and other work is delayed for lack of cash in hand which would be ordered if easy payments were available. The damage done to a building which is not repainted when it should be is irreparable—can never be replaced.

One finance company in Chicago is now lending money throughout Cook County for extensions, additions, alterations and repairs on the basis of 1 per cent a month for six months. All they require from the builder is a waiver of mechanics' liens, which they consider sufficient security when dealing with property owners. They advance the cash to the builder as fast as the work is completed upon receipt of the owner's note and the builder's waiver of lien.

## Financing Plans Now Used

The Save the Surface Campaign, with headquarters at Philadelphia, has appointed a sub-committee to investigate and report on methods of financing easy payments on painting and decorating jobs. In their report on this subject, the committee points out that one finance company in the city of Philadelphia has been financing painting contracts for a period of several months past. The finance company advises that one painting contractor whose work they have financed attested to the fact that 95 per cent of his business had been secured because he was able to offer easy terms.

Another finance company has financed along similar lines electrical wiring contracts and reports that one electrical contractor whose capital was \$5,000 had discounted, within six months' time, \$100,000 worth of contracts.

The Save the Surface Committee recommends co-operation with Morris Plan Banks, building and loan associations and local financial institutions to finance painting contracts on easy terms of re-payment.

For the erection of new buildings, the builder has recourse to the usual methods of financing building loans—first, second and third mortgages. If the owner has not sufficient money after receipt of the first mortgage loan to pay the complete construction cost, the builder can take second and third mortgages which can usually be sold in the larger centers. To do this, however, the commissions on two or three loans is heavy and forms a burden which must be passed back to the purchaser in the form of a higher contract price.

Where the builder owns the land, he can sell on contract or have the purchaser assign title to his lot, raise a first mortgage loan on it, get a signed contract from the purchaser for the balance and "shave" the contract, but this exposes the purchaser to a possible loss of his title if he misses a payment, as he has no title whatever. Loan sharks are prone to take advantage of this. With a mortgage, there is, in most states, a 15 months' redemption period before foreclosure, which is much safer for the owner.

Mr. D. F. Laist, architectural adviser for the National Lumber Manufacturers' Association, outlined a plan of financing easy payments at a

meeting of the Ohio Retail Lumber Dealers' Association. The plan has many merits and is, briefly, as follows:

## A New Plan Suggested

The building material dealers, local builders and sub-contractors to take shares in a local loan company. This loan company to advance the amount necessary to "bridge the gap between the amount of the first mortgage loan and the amount necessary to complete the building." The money from the first mortgage loan is prorated among dealers who furnish material, builder and sub-contractors who install fittings and equipment. For the balance due them, each takes the owner's note. The loan company then discounts each of these notes for a moderate discount and pays the cash to dealers, builder and sub-contractors upon their endorsement of the owners' notes. This sounds like a commendable and feasible plan.

## What Are Your Ideas?

We would like to hear from our subscribers on this question. We think it is worthy of discussion and one which may have an immediate bearing upon local building plans this spring. Write us a letter giving us your views.



Many People Would Like to Build but Lack Ready Money. Easy payment systems open new fields for the building contractor.

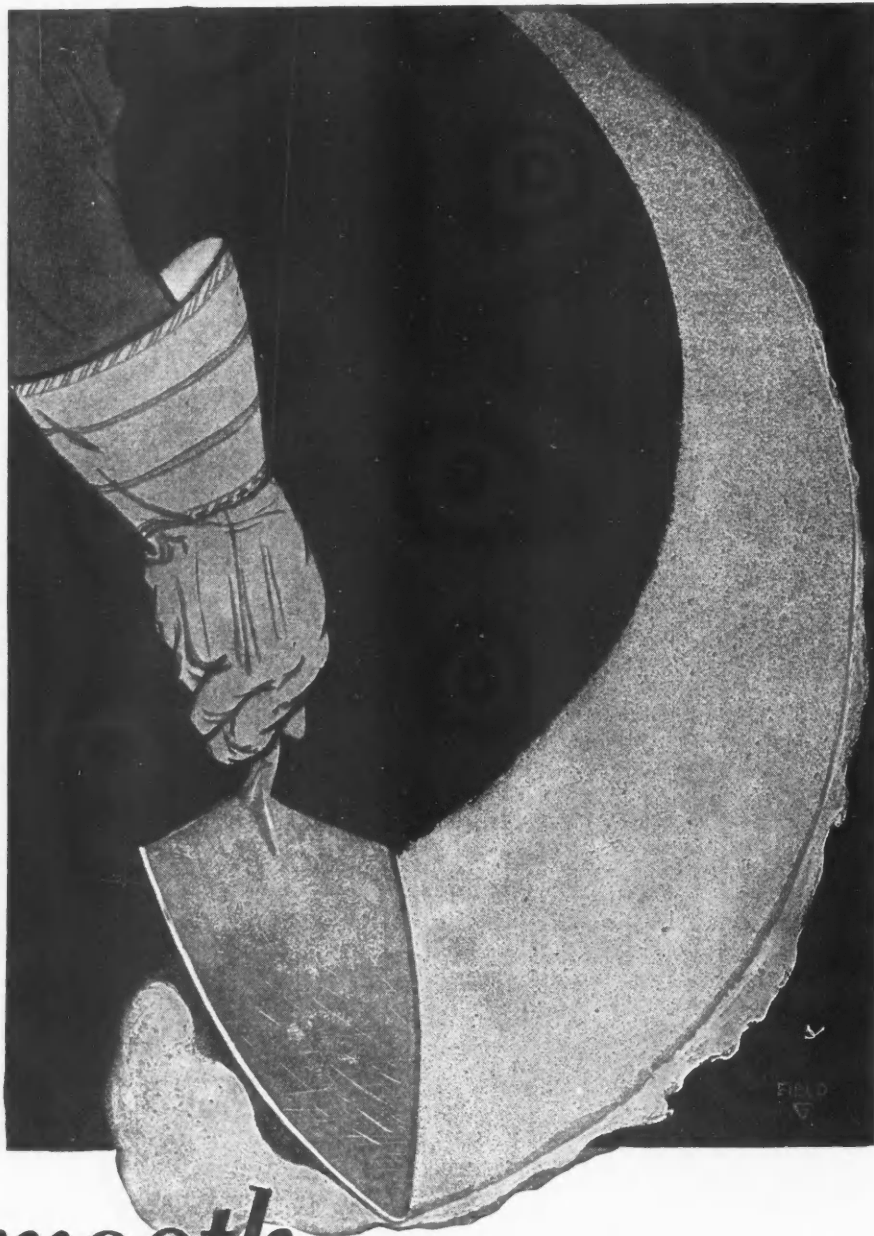

*Smooth* as soft butter! The exceptional plasticity of BRIXMENT mortar is another reason why masons using it do faster, better, more economical work. It repels moisture and is thus less likely to freeze, crack or scale. Try it yourself and be convinced in actual practice.

**BRIXMENT** is a standard, mason's cement of proven strength, endurance and economy. No lime. No slaking. Can be used immediately after mixing. Can be retempered. Will not fade mortar colors and requires less color to obtain desired effects. Sold through dealers. Further details on request. Louisville Cement Company, Incorporated, Louisville, Kentucky.

*for Better Masonry*

# BRIXMENT

WHEN WRITING ADVERTISERS PLEASE MENTION THE AMERICAN BUILDER

# Westchester's House Beautiful Is Fine Type of Country Home

LEWIS BOWMAN, ARCHITECT

THE model demonstration house, erected by The Building and Realty News, of Westchester County, New York, bears the well deserved name of "Westchester's House Beautiful." The English style, selected by the architect, Mr. Lewis Bowman, of Mt. Vernon, N. Y., is a thoroughly appropriate type for the modern country home, of which this house is an example.

After selecting the type of house, the foremost thought was for the reduction of upkeep, with the result that the

probability of repair bills within ten years has been reduced to the minimum, an item of much consequence in the ultimate cost of home building.

A large number of well known firms co-operated in the erection, equipping, furnishing and decorating, and the building has been called the most complete modern home in New York City suburbs. It is located on Mamaroneck avenue, White Plains, and has attracted several thousand visitors since it was first opened for inspection.

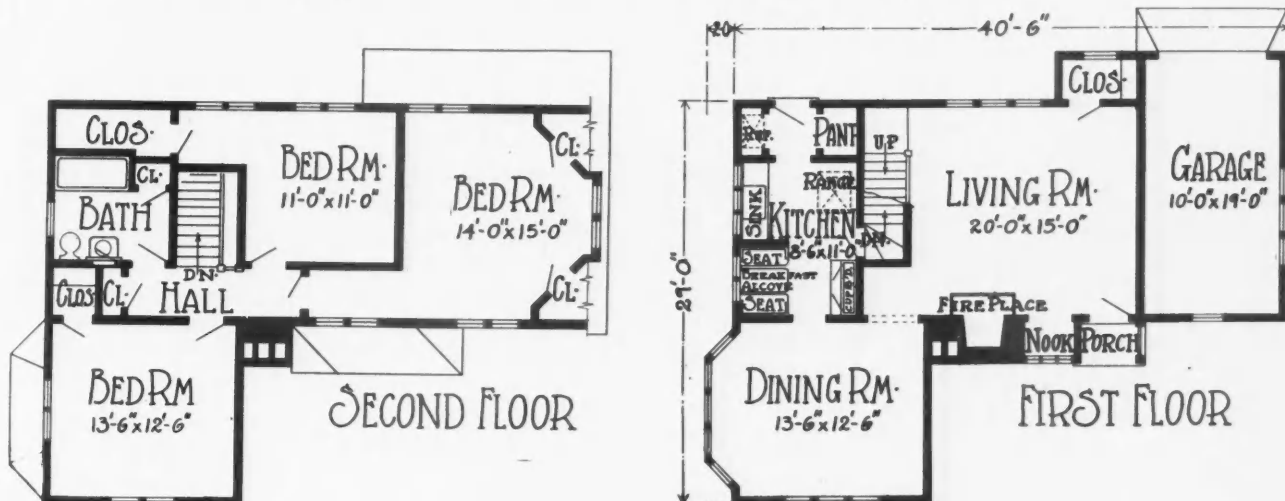

The Building so Thoroughly Harmonizes with Its Surroundings that It Seems to Be a Part of Them. The floor plan shows the thought given to comfort and convenience in every detail from the large closets to the built-in garage.



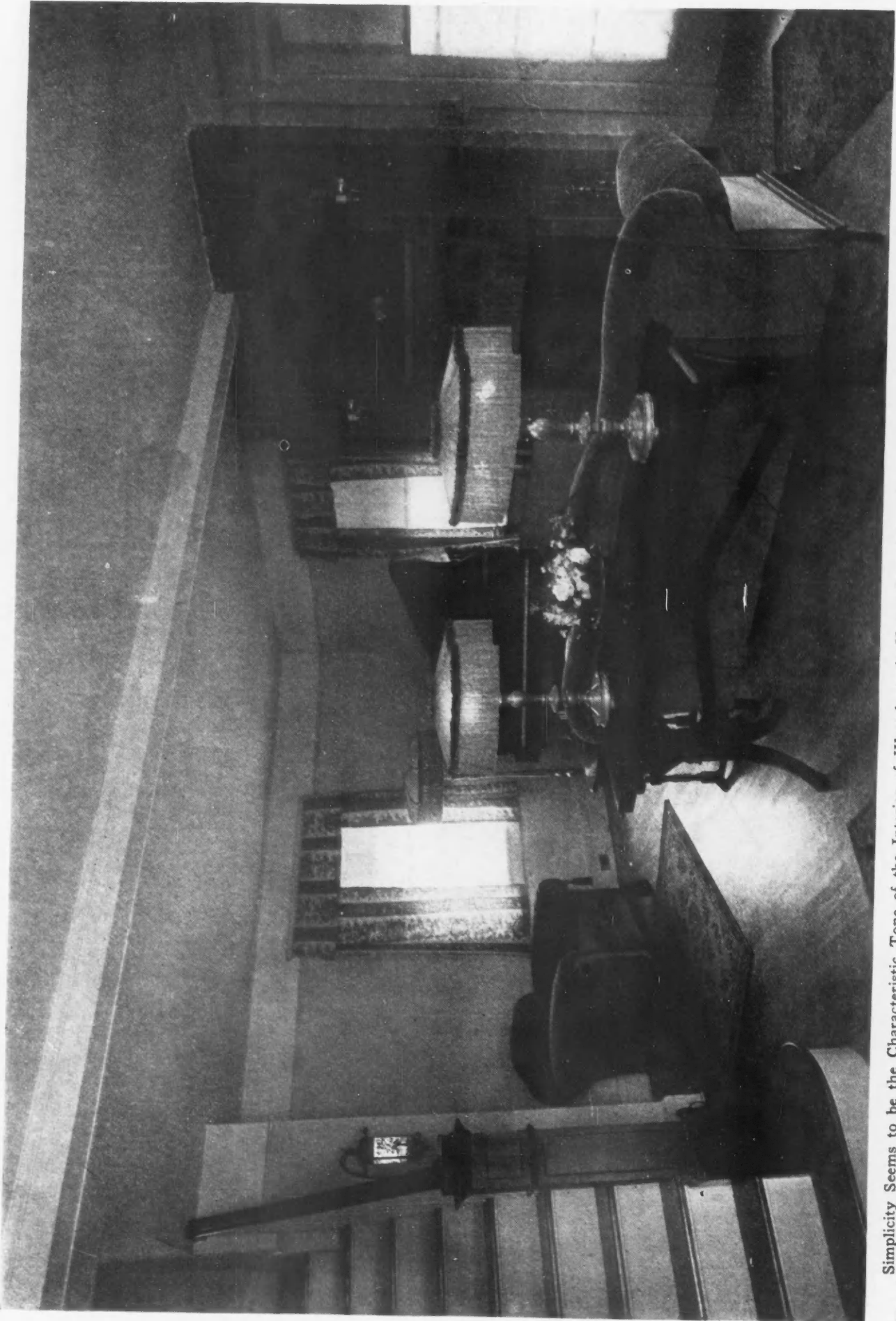

Simplicity Seems to be the Characteristic Tone of the Interior of Westchester's House Beautiful and no Decoration Is More Satisfactory than Artistic Simplicity. This living room, which might otherwise seem cold, is given just the right warmth by the bright window drapes, the upholstered furniture and the well placed lamps and rugs, while the rough brick fireplace makes one look forward to the long winter evenings with a blazing wood fire.





The Kitchen, Above, of the Westchester House Beautiful, Is Carefully Planned to Offer All the Conveniences of Equipment and Arrangement While the Breakfast Nook Is Cheerfully Lighted by a Big Window. Just beyond is the dining room which is in complete harmony with the tone of the living room shown on the preceding page.

# Unique State Capitol Design

Also a Fine Office Building, Training School, Exposition Building and State Capitol Included in this Month's Art Supplement

By **BERNARD L. JOHNSON,**

*Editor, American Builder*

**S**HOULD American capitol buildings all be cut after the same pattern? At least one architect—the late Bertram Grosvenor Goodhue—said, “No,” and provided a noble alternative. This building, still under construction, has been described as one of America's architectural masterpieces.

An illustrated article in regard to this capitol was printed in *AMERICAN BUILDER* as long ago as June, 1922. However, this beautiful perspective has never before been illustrated in full page duotone lithography. We believe our readers will agree that the reproduction in this month's Art Duotone Supplement is well worth while.

Other notable buildings are included in this month's selection. We are glad to present a perspective of the Pacific Telephone and Telegraph Building, San Francisco, as a particularly fine example of the many modern office buildings being erected in Pacific Coast cities, where building has been extremely active.

## Pacific Telephone and Telegraph Building, San Francisco, Cal.

The architects of this building—J. R. Miller, T. L. Pflueger and A. A. Cantin—made exhaustive surveys of the surroundings as well as mass and model studies of the building, in order to be sure that it fitted its environment and that there was no light or other interference from nearby structures.

The building occupies a site 160 by 147 feet, has equal faces at right angles on two intersecting streets and has an ell-shaped light court at the back. It is 500 feet high to the tip of the flagpole and contains 26 stories. The outer walls are faced with granite color terra cotta, except on the light court faces, which are of enamel brick, to match. The cost is estimated at four million dollars and the building is expected to be ready for occupancy in August of this year.

## Training School for Teachers, New York City

The architects for the Board of Education of the City of New York—William H. Gompert and Mortimer D. Metcalf, associate—are to be congratulated upon this exceptionally fine training school design, as illustrated in this month's art duotone perspectives.

The building activity of the New York Board of Education is indicated by the fact that, in seven years, their building program has involved an expenditure of \$150,000,000 in order to provide proper educational facilities in this great metropolis.

The new Training School for Teachers will be located on West 135th Street between St. Nicholas Terrace and Convent Avenue. The building will contain seven stories and basement and its dimensions are to be 263 by 220 feet. The architecture is to be Cathedral Gothic; the construction to be of the skeleton type with curtain walls of brick and

trimmings of limestone.

Showers, toilets, dressing rooms, locker rooms and class rooms are provided for every department and the equipment and furnishings will be of the latest and most modern type. There will be several gymnasiums, laboratories, science rooms, rest rooms, teachers' rooms, libraries, offices, a manual training room, music rooms, cafeteria, teachers' lunch room, kitchen and other departments, also an auditorium which will seat 1,200 persons.

## The Textile Exchange

Several large buildings have been built and projected in Chicago recently to serve the purpose of centralizing display and buying markets for various line of merchandise. The Furniture Mart—the world's largest building—has been so successful that land has been bought and plans drawn for an annex to be built in the near future. The Jewelers' Building is a projected building of this type, also the Produce Exchange, as also the Textile Exchange, illustrated in this month's Art Supplement.

The building is to cost \$5,000,000 and is to be located on Lake Shore Drive near the site of the Furniture Mart, between Erie and Ontario streets. It will be 240 feet square with a 120-foot club-hotel annex building.

The architect, Mr. Joseph C. Ludgin, has provided plans for a building which will be a credit to this fine neighborhood, with sweeping vertical lines which accentuate the height of the building and a gracefully designed tower at the corner. A lesser tower

marks the dividing line between the main building and the annex.

The promoters, S. H. Shoninger and Hugo Du Brock, expect to have on display in this building representations of every important textile manufacturer on display. The plans call for a large roof garden with a complete stage on the roof of the club section, where fashion revues, exhibits, etc., can be given.

## Nebraska State Capitol, Lincoln, Nebraska

Architects, as a class, are generous in their recognition of meritorious design even when it upsets a precedent. The late Bertram Grosvenor Goodhue has admittedly designed a masterpiece in the Nebraska State Capitol which won a series of architectural competitions in June, 1920.

The design of this capitol departs entirely from precedent in American state house construction, which, in turn, seems to have had its inspiration from the dome of St. Peter's or the Temple of Jupiter in Rome. The main feature of Mr. Goodhue's design, of course, is the majestic but beautiful tower rising to a height of 400 feet and surmounted by a heroic figure called “The Sower.” This tower will be 80 feet square at the base and has a colored tile dome rising above an octagonal section of great effectiveness.

The main building is approximately 440 feet square, set on a terrace with a stairway of heroic proportions.

### WHAT IS YOUR OPINION?

How do you like the Art Supplement and its presentation of the architecture of notable buildings? Do you find these plates beautiful—interesting—informing—or would you be more interesting in a different type of buildings? Your suggestions will be welcomed, as we want to present this department in the way which will be most inspiring and helpful to all who are interested in architecture. Simply address your letters to the Editor, *American Builder*, Chicago, and they will have our personal attention.

# ART SUPPLEMENT *of* NOTABLE ARCHITECTURE



PLATE XXI

*The* PACIFIC TELEPHONE & TELEGRAPH BUILDING, San Francisco, Calif.; J. R. Miller & T. L. Pflueger and A. A. Cantin, Associated Architects. This Four Million Dollar Building, 26 stories high, will be completed in August, 1925.

*The* AMERICAN BUILDER, March, 1925



AMERICAN BUILDER ART SUPPLEMENT OF NOTABLE ARCHITECTURE, March, 1925

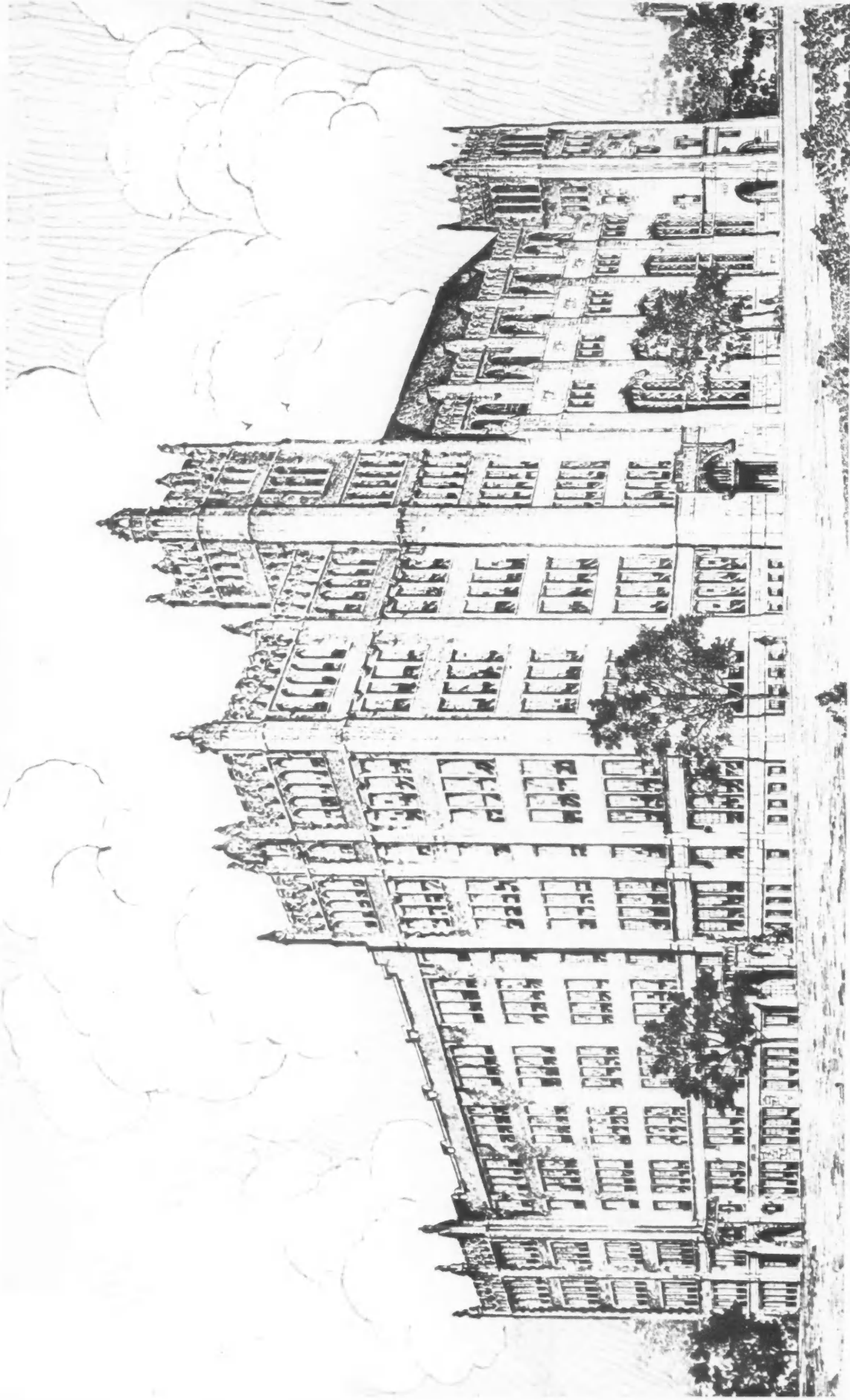

PLATE XXII

The NEW YORK TRAINING SCHOOL FOR TEACHERS, W. 135th St., New York City; Wm. H. Gompert, Architect. This immense 7-story building, 262 by 219 feet, is part of the \$150,000,000 school building program now being put through by the Board of Education of the City of New York, under Mr. Gompert's supervision.





The TEXTILE EXCHANGE, Chicago, Joseph G. Ludgin, Architect; to be built on Lake Shore Drive at Erie Street. A design notable for its strong vertical lines and absence of cornice.

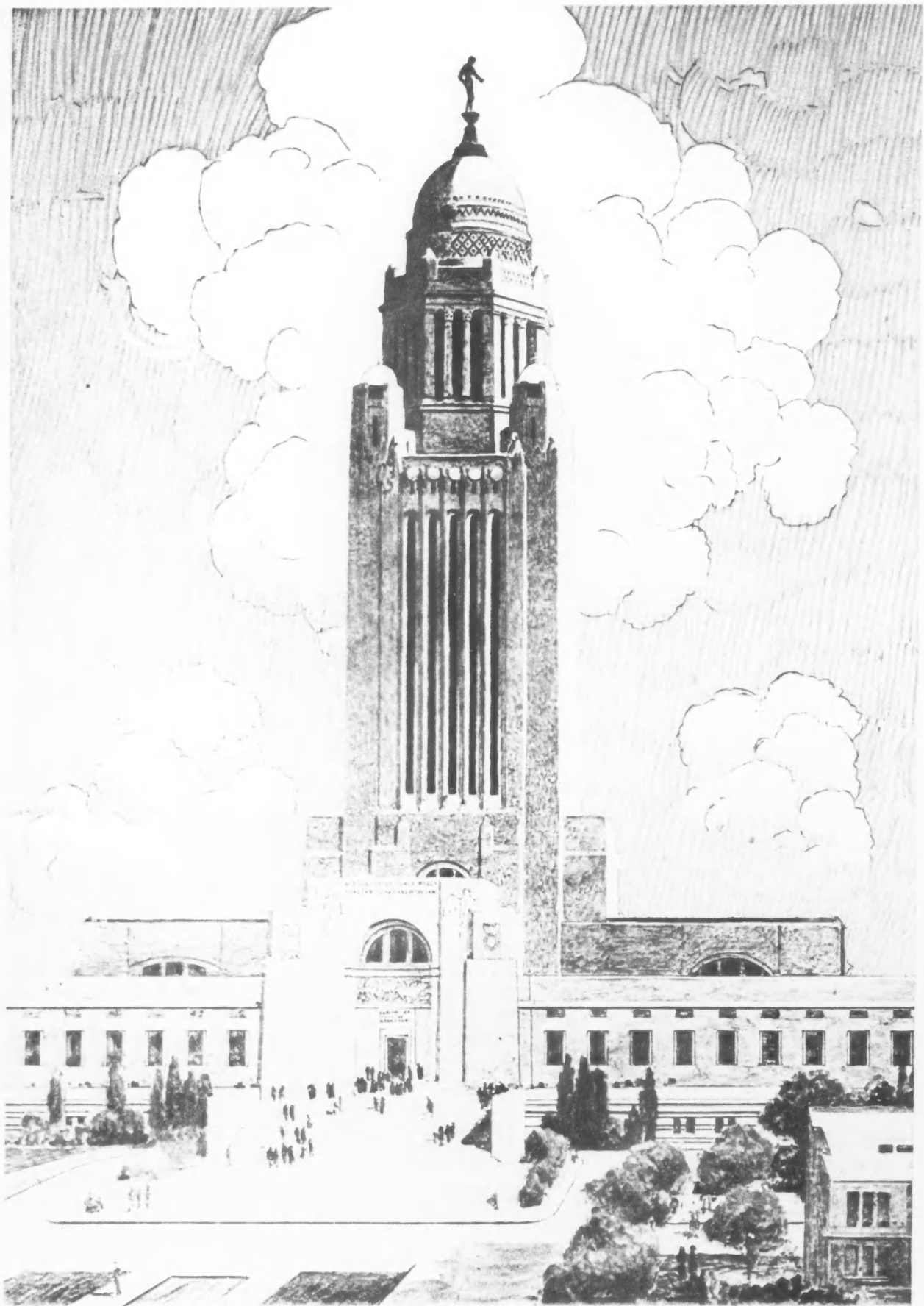

PLATE XXIV

The NEBRASKA STATE CAPITOL, Lincoln, Nebr., Bertram G. Goodhue, Architect, has occasioned world-wide comment and admiration since this prize winning design was selected and ground broken in April, 1922.

# Built-in Equipment Used Throughout the Biltmore Apartments

By MAX SOMMERS

**A**MONG the most modern of newly constructed apartment buildings in Portland, Oregon, is the Biltmore Apartments at Twentieth and Glisan streets, which was completed last year; John H. Grant, architect.

The building is of reinforced concrete construction, with stucco exterior and Spanish cornices. It is built in a double "U" shape around 50 by 50-foot court. The front entrance,

which is of vestibule type, having a red slate roof, faces upon a small lawn set with trees and shrubs. The entrance is approached by a short flight of red brick steps, with tall lamps on each side. The fire escapes and the small steel balconies outside the central suites are painted white to correspond with the walls. The building consists of four stories and basement and is thoroughly fireproof.

There are 49 suites, of two, three and four rooms. The large suites are equipped with sun parlors, reached by French doors, this type of door also being used to give entrance to the balconies and between the living and dining rooms. Each suite has a bathroom with tiled floor and built-in bath tub, shower and drug cabinet.

The kitchens are small and compact and have every possible labor-saving device within easy reach. These include a sink with drain table attached, pair of kitchen steps, built-in kitchen cabinets, cupboards and refrigerator, and electric range. The kitchen opens on a dining room of the same size, flanked by glass-doored china closets.

The living room is equipped with a double concealed bed which pivots into a closet in which are two large wardrobes.

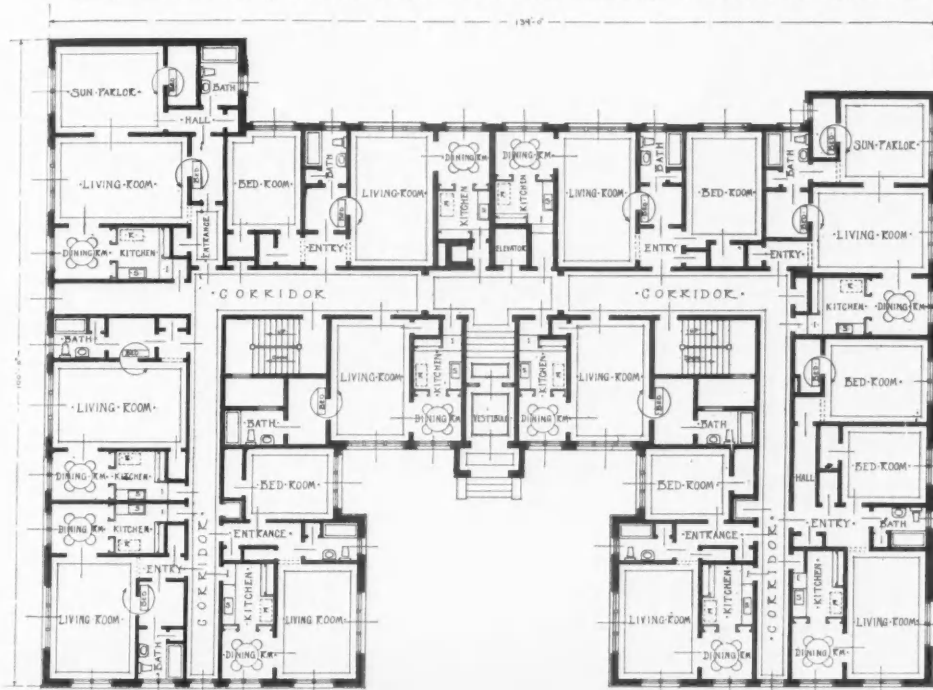

The Biltmore Apartments, Portland, Ore., John H. Grant, Architect, Are a Fine Example of the Possibilities of Space Saving Through Built-in Equipment. The floor plan shows the compact arrangement of the 49 two, three and four-room suites which are a model of light, ventilation and convenience.



# Built to Rent at \$27.50 Per Month

Frank F. Woolling, Indianapolis Builder, Makes Big Success with His "Baby Grand Doubles" Which He Builds and Rents Partially Furnished



Frank F. Woolling, Indianapolis Builder, Whose "Baby Grand Doubles" Provide Young Couples with a Chance to Save Their Money Toward the Day When They can Build Their Own Home.

JUST when all the eligible young men were being frightened away from matrimony by the high cost of living and the young women were thinking they didn't want to keep house, because housekeeping meant either being cooped up in a room or two of a big apartment house where it was difficult to find your own entrance door, along comes Frank Woolling, an enthusiastic Indianapolis home-builder, and offers to young married couples, and old ones, the "baby grand double"—a double bungalow with all the conveniences of an apartment and all the sunlight and open air and privacy of a bungalow.

The baby grand double, as Mr. Woolling terms his delightful new type of house, is his own invention, but the rapidity with which the clever little houses are renting will no doubt lead to many imitations.

The best part of the baby grands is that they are to be rented, not sold; all the capital a young couple needs in order to start housekeeping in one of them is the price of a few pieces of furniture, and thanks to Mr. Woolling's foresight, one doesn't need much money or much furniture either.

The little "baby grands" rent for only the least bit more than the most ordinary three-room cottage. Each has a complete living room, a complete bed room and the most attractive combination dining room and kitchenette, toilet and "bathette" that any woman could desire. The exterior of the "baby grands" musn't be passed by without mention, for no one would pass one of them by without giving them an admiring glance, and a woman would be almost sure to exclaim, "What a darling place!"

For Mr. Woolling has taken special care to plan an artistic exterior for his "baby grands"—in keeping with the interior. Some of them have roofs of silvery gray tile, some show tiles of soft blues and greens and reds intermingled, some will be roofed in all green and some in dull red. All are dis-



Mr. Woolling Has Taken Special Care to Plan an Artistic Exterior for His "Baby Grands." Tile roofs in soft grays, blues, greens and reds set off the gray and ivory of the walls and trim. Each house has a private back yard with a garage and coal bin at the rear and plenty of room for a garden.



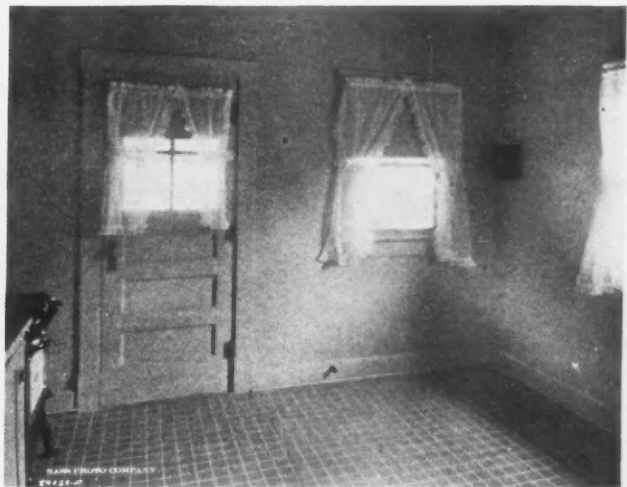
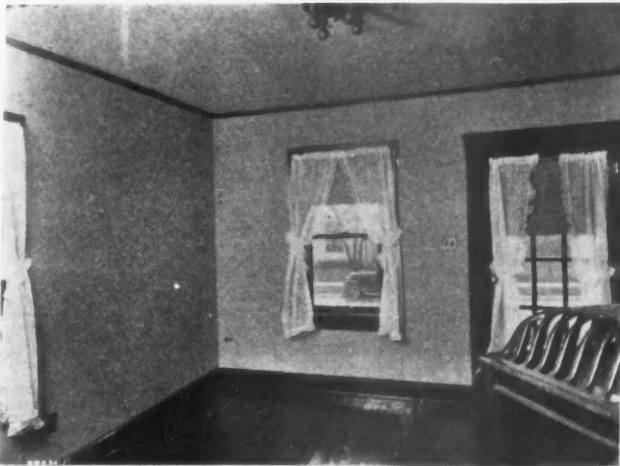

In the Living Rooms an Embossed Paper of Silver Gray, Walnut Stained Floors, French Door and Wide Windows with Shades, Fixtures and Curtains and the Efficient Heater Provided Make an Attractive Effect.

Each Kitchen Is Furnished with a Gas Range and a Built-In Cabinet Enameled to Match the Woodwork, in Ivory and a Block Pattern Linoleum in Blue and Ivory Covers the Floor.

tinctive in their coloring. The outside walls are painted in soft grays and the trim is of ivory, making the whole most attractive. And here are a few of the additional exterior features and not found in the average rental property.

Each "baby grand" has a private back yard, fenced in from porch to garage with an ornamental iron fence, so that the baby or the dog has a place to play or the garden may grow undisturbed by wandering chickens. Each "baby grand" has its own garage. Built into one side of the garage is a coal bin, so that the coal wagon drives up the alley, empties the winter supply of coal into the bin and all the man of the house needs to do is to bring it in, a week's supply at a time, to the covered concrete coal reservoir at one corner of the large back porch.

The moment one steps into the living room he appreciates the good taste and excellent thought that went into the planning of these unusual houses. The best apartments are no more attractively

**FRANK F. WOOLLING**  
Real Estate  
Continental Bank Building  
Indianapolis

January 23, 1925.

**MR. BERNARD L. JOHNSON,**  
Editor **AMERICAN BUILDER,**  
1827 Prairie Ave., Chicago, Ill.

Dear Mr. Johnson: I am enclosing by separate package the only photographs I have had taken of the Baby Grand Development. I am not particularly proud of the pictures as the houses are not completed on the outside to any further degree at this time than the pictures show.

However, we have twenty-six occupied and have just laid down boards for the tenants to get in through the mud and they paid their rent from the day the inside of the houses were finished. There is just a prime coat of paint on the outside and the weather has been so cold we couldn't get in cement walks or steps up to the front porches, and the tenants occupying same are using the back door. You will have to imagine these houses painted up in beautiful shades of grays, ivories, white and greens, with the lawns graded and shrubbery banked around each little house. We are making full length cypress screens and doors for every opening and of course will place trellises and lattice work for rambler roses at some point on each house, and, believe me, my gardener will set out roses that will be blooming in sixty days after old stock is planted.

My list of people waiting to get into the apartments are young folks who are paying as high as \$65.00 a month rent and are really high-class and sincere people who are willing to furnish for themselves all the service they have been paying for in apartment houses and are desirous of building up a bank account in some good building and loan association with the difference they save in rent. These houses are renting for \$27.50 per month. It would really do you good, interested in your bigger way of promulgating the building of homes for the American public, to hear some of the people talk who daily call up my office. The rental success of this deal is just away beyond my fondest expectations.

Very truly yours,  
**FRANK F. WOOLLING.**

papered than the "baby grands."

In the living room and bedroom, an embossed paper of silver gray has been used, with walnut stained floors and woodwork. A wide side window supplements the French door and the window at the front in the living room, yet ample space has been left for all the necessary furniture.

There are ivory-toned shades at the windows, but the builder has not stopped with shades. He has included curtain fixtures and ruffled, tie-back marquisette curtains at every door and window from the front of the house to the kitchen. There is a big space between the front window and the side window for the over-stuffed davenport, which may be of the type that can be converted into an extra bed if one needs additional bedrooms. Besides the space for the davenport is an electrical outlet for the bridge lamp, and in one corner is an ideal spot for a gate-legged table and large chair, while in the opposite corner is the heating plant, a sort of "inside the house" furnace, with furnace heating capacity but a base-burner appetite for coal.

According to Mr. Woolling, these new heaters have been tested and found to go through an entire winter on three tons of coal, which is even more in their favor than their attractive appearance. Unlike the old base-burner, they throw the heat to the top of the room instead of scorching everything within three feet of them, and the upper walls of the "baby grand" have narrow openings near the ceiling so that this warm air is effectively distributed through the house.

In the bedroom, where space

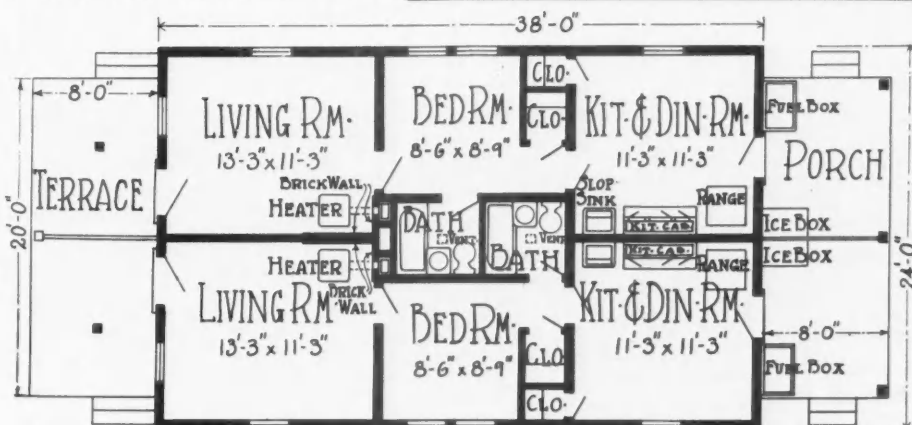

Mr. Woolling Builds His "Baby Grand" Doubles in Two Sizes, 24 by 38 Feet, Arranged Like This and Renting for \$32.00 a Month, and 24 by 36 Feet, Renting for \$27.50 a Month. In the smaller plan the bathtubs are omitted and the bathroom space divided into four units, two toilets and two clothes closets.



These "Baby Grands" Were All Rented as Fast as They Reached the Point Where They Were Habitable, Without Waiting for the Completion of Outside Painting, Cement Walks, Grading and Other Details. There is now a waiting list of young people who are paying as high as \$65.00 a month in rent but are anxious to grasp this opportunity to start saving for a home of their own.

has been provided for a full size bed, dressers and chiffonier, there is a lighted wardrobe, and next to it, opening from the kitchen, is a modern toilet.

The kitchen is the most delightful room of all. There is a gas range furnished with the house; also a built-in cabinet enameled, to match the woodwork, in ivory. At the windows there are dainty curtains, on the floor there is block-patterned linoleum in blue and ivory.

Mr. Woolling has explained his purpose in building his "baby grand" doubles, in the following words:

"Our government put on an 'Own Your Home Campaign,' because home ownership develops better citizens, and the results were wonderful; but say, how are the young married folks just beginning life, going to save enough money to buy a home when it takes all they can make just to barely live? They have been reared in homes that have taken the best part of their parents' lives to create; and, naturally, they want to start in a like manner. Now, in the cities, what option have they? Either rent an unmodern, unsanitary house, absolutely opposite from what they have been used to, or rent a one-room, kitchenette and bath in a big apartment hotel at a price they can't afford to pay, and with their nose to the grind-stone trying to get by, it's mighty easy for either the husband or the wife to become dissatisfied, and through the many devious ways of that kind of living, end up in the divorce court.

"Now, if they could rent a small, clean, efficient house at a price within their income, they would be only too glad to keep the home fires burning, cut the grass, and scrub their walks and steps. And the very fact of their rendering these homely services would tend to hold their interest, build up their civic pride and give them a chance to save up their money to buy a home of their own; and the building of these small rentals is the creation of the 'Stepping Stones,' if you please, to the young folks dream home. If they start right, live thriftily and earnestly their dreams will come true and they will enjoy home ownership.

"All over this country there is every reason in the world for producing small, highly efficient houses to rent. Calling a small double house an apartment has a far greater appeal to the renting public than if you advertised a double house. It's hard to get attractive names for these developments. Now, if you AMERICAN BUILDER readers care to take these down, I'm going to slip you a few good names for small cellarless, bungalows, double, dolled-up inside like out modern apartments—Baby Grand Apartments—Jennie Wren Apartments—Peter Pan Apartments—and Pollyanna Apartments."



### Recommend Subdivision Control

A STUDY of the control of subdivision development was recently undertaken by the Home Builders' and Subdividers Division of the National Association of Real Estate Boards, under the direction of Irenaeus Shuler, of Omaha.

Good control, within corporate limits, was found in seventeen cities, partial control in six cities and no control in one city. For control outside of corporate limits the figures were eleven good, three partial and twelve cities no control.

The report recommends a master plan for the whole of any metropolitan area, including a radius of three miles outside of corporate limits. Such a master plan is used in three of the cities at the present time and has been adopted and is in preparation for three others. The master plan provides for future street extensions, sewers, grades, transportation facilities and other improvements which should be co-ordinated with city development in territory which will probably become a part of the city.

No recommendation is made for the placing of such control except that it should be in the hands of the governing body best fitted to handle it by the existing local laws.



### High School Building Course

THE first building construction course to be adopted as a regular four-year high school course has been established in the Roosevelt High School, Los Angeles. This course includes general instruction in selection, storing and use of brick, cement, sand, lime, rock, etc.; project work covering everyday use of concrete and brick; instructions in form work and scaffolding; construction methods devoted to the development of details, showing foundations, floors, walls, beams and plain columns made from concrete; instruction in individual and group project in various types of building construction and engineering work; test of sand, cement and brick; test and use of plaster for interiors; test of roof tile (clay and cement) for color and water tightness; instruction in fireplace and chimney design.



### Building Congress Honors Boyd

THE first 1925 meeting of the Philadelphia Building Congress, January 16, took the form of a dinner in honor of D. Knickerbacker Boyd, president of the Congress. Mr. Boyd has announced his intention of retiring from office at the end of his present term, and this was considered an opportune time to publicly acknowledge his able work for the betterment of the building industry.

The dinner was attended by ninety-four members and friends. Many messages of tribute to Mr. Boyd were received from all parts of the country and the speakers referred to his continuous service, his visits to more than three-quarters of the chapters of the Institute, his collaboration with the Department of Commerce in mitigating seasonal unemployment, his work with the building material associations on standardization, basic specifications, pride of craft, apprenticeship training and innumerable activities with public educational institutions, contractors, and others.

# Furnishing the Spanish Interior

Illustrations from "Dias Dorados," the Estate of Mrs. Thomas Ince, Beverly Hills, California, Roy Seldon Price, Architect

By MARION BROWNFIELD

**T**HE Latin influence on both architecture and home furnishings was never more apparent than at present. "Castles in Spain" are being built in such variety, right here in America, that every type of home from the studio apartment to the mansion may reveal a charming Spanish interior.

In every branch of Spanish decorative arts, there are "examples which seem to recall Italy in design, Flanders in perfection of workmanship, and an ever recurring Oriental note, which is reminiscent of the Moor." In metal, leather and iron, which were all important details of Spanish furniture, both the Flemish and the Moorish contributed ideas. This explains why Jacobean furniture, considered an English style, harmonizes with Spanish furniture. William and Mary brought it from the Netherlands, and thus the two styles have a common Dutch heritage.

Distinctly different were the influences of the New World, on Spanish furniture. These tended to two different effects. One style was the simplified Spanish made necessary by the pioneering of the Mission padres, and the other while still monastic in design was strongly influenced by the native Indians. This type of Spanish furniture has appropriately been called the

"pueblo style." It combines primitive vigor with Indian motifs in design. Many of the Spanish colonists saw the decorative possibilities in Aztec motifs with their bold simplicity portraying symbolically all the mysticism of nature. The Indian pottery, baskets and rugs are echoes of the desert where the sun unites earth and sky. And the new Spanish settlers carved beamed ceiling, paneled walls and doors, friezes and borders, as well as furniture in Indian style, with now and then a Spanish heraldic device intermingled!

The background of course was simple stucco walls, with gracefully arched opening descended from the Moors to the Mission days. Tiled floors reflect both Moorish and Indian art. Hand wrought iron was used for both the quaint hardware—such as door hinges and locks, and very handsome lighting fixtures. Candle scones notably relieved the austerity of natural toned plaster walls. However, the tie with old Spain still being strong, luxurious hangings were imported by the wealthy. This note of color is probably the most fascinating thing in a Spanish room.

Yet Spanish furniture has decided beauty in itself. Besides tables, chairs, chests, stools, and bedsteads, there were a number of original pieces—among them



With the Vogue of Spanish Homes Comes the Need for Knowledge Concerning their Proper Decoration. This interior is from the home of the late Thomas Ince, Beverly Hills, California. Roy Seldon Price, Architect.



the "arcon" or curved top sea chest and the famous vargueno.

The vargueno is a small rectangular cabinet with a hinge, that lets down the lid; it was gradually developed into an elaborate and useful piece of furniture. A sliding drawer beneath is credited to the Moors, as

well as certain open work metal plaques seen in sixteenth century models. Later the vargueno was placed upon a stand, which had a characteristic arrangement of spirally turned columns frequently connected lengthwise by arcades. Carved shell work was a decoration symbolic of St. James, the patron saint.

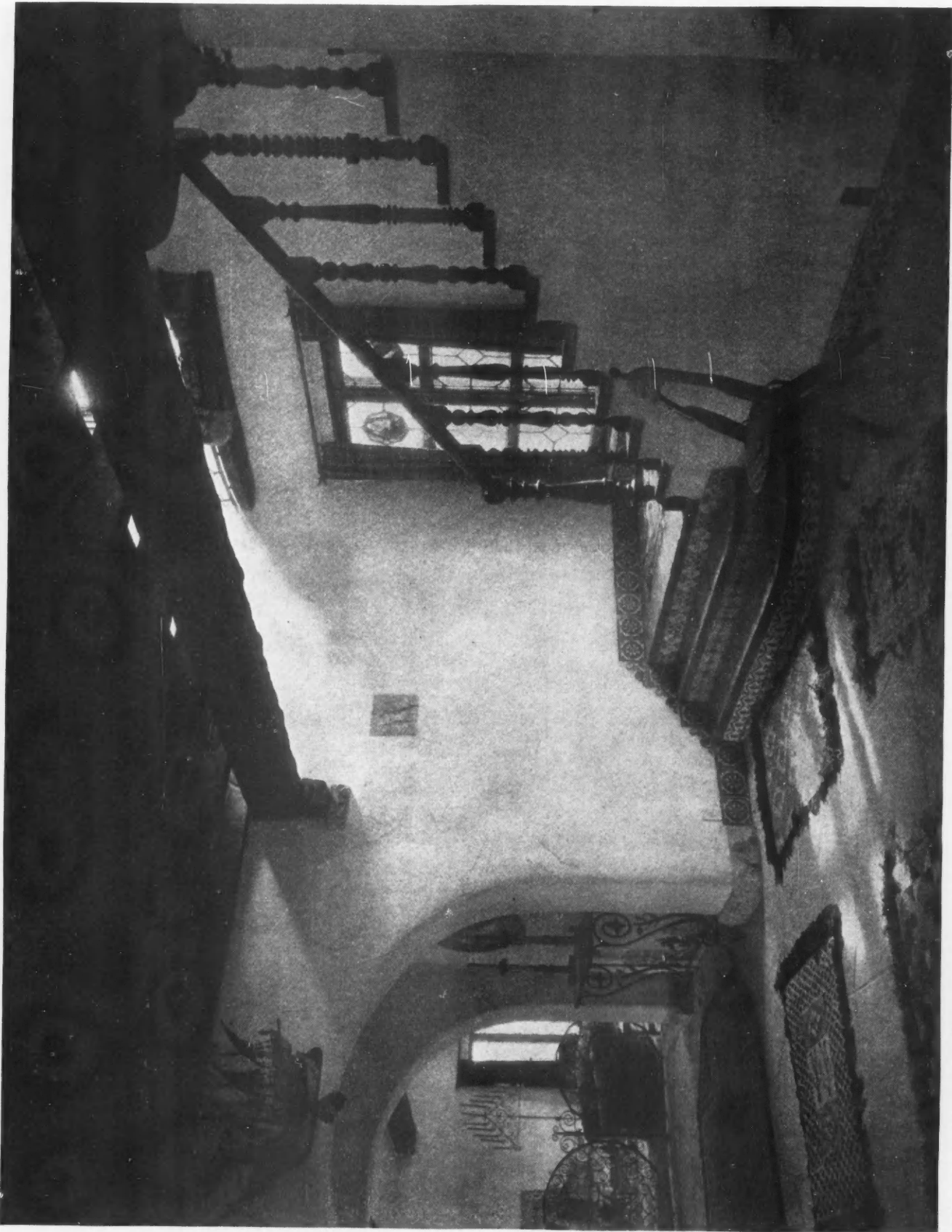

The Heavy, Beamed Ceiling, the Quaint Stairway with Its Variety of Balusters, the Tile Floor and the Plaster Walls Form a Fitting Background for Wrought Iron Work So Much in Evidence in the Interior of Dias Dorados, the Home of Mrs. Thomas Ince.



Most of the typical Spanish furniture was walnut, which fits harmoniously into any Latin interior. Sometimes walnut was polychromed or gilded, but chiefly as a decoration. Metal mountings were exceedingly popular and both gilt and iron were used over red velvet. Chairs were upholstered with both velvets and leather. Tooled leather, indeed, is notable on seats, stools and screens. The Moors sat on cushions, so chairs developed slowly, and the canopied bench was one of the first styles. Later both high and low backed arm chairs were upholstered.

A tall hanging cupboard or armoire was another distinctive Spanish piece, while a small cabinet or drawers designed to stand on a table is the "papelera." What a fascinating adornment for a modern writing table! The refectory table, being of monastic origin was equally at home in the New World. Spanish style tables usually have scroll or carved trestle legs connected by wrought iron stretchers. The legs flare at the base, and the top is frequently a thick walnut plank.

Color is strong in Spanish fabrics. Because it is needed to give warmth to stucco walls and tile floors, it can be used quite daringly in both hangings and



upholstery. A charming scheme, indeed, is the rug or "throw" hung solely for its pictorial effect.

Many of the Spanish weaves for upholstering have been cleverly simulated by modern manufacturers. Among these are tapestry, velvet, brocatelle, brocade and antique satin. For tall chairs, "flame point" tapestry with its lure of color is successful when the figure is used "up and down." Verdure tapestry, figured and Genoese velvets are harmonious for upholstery.

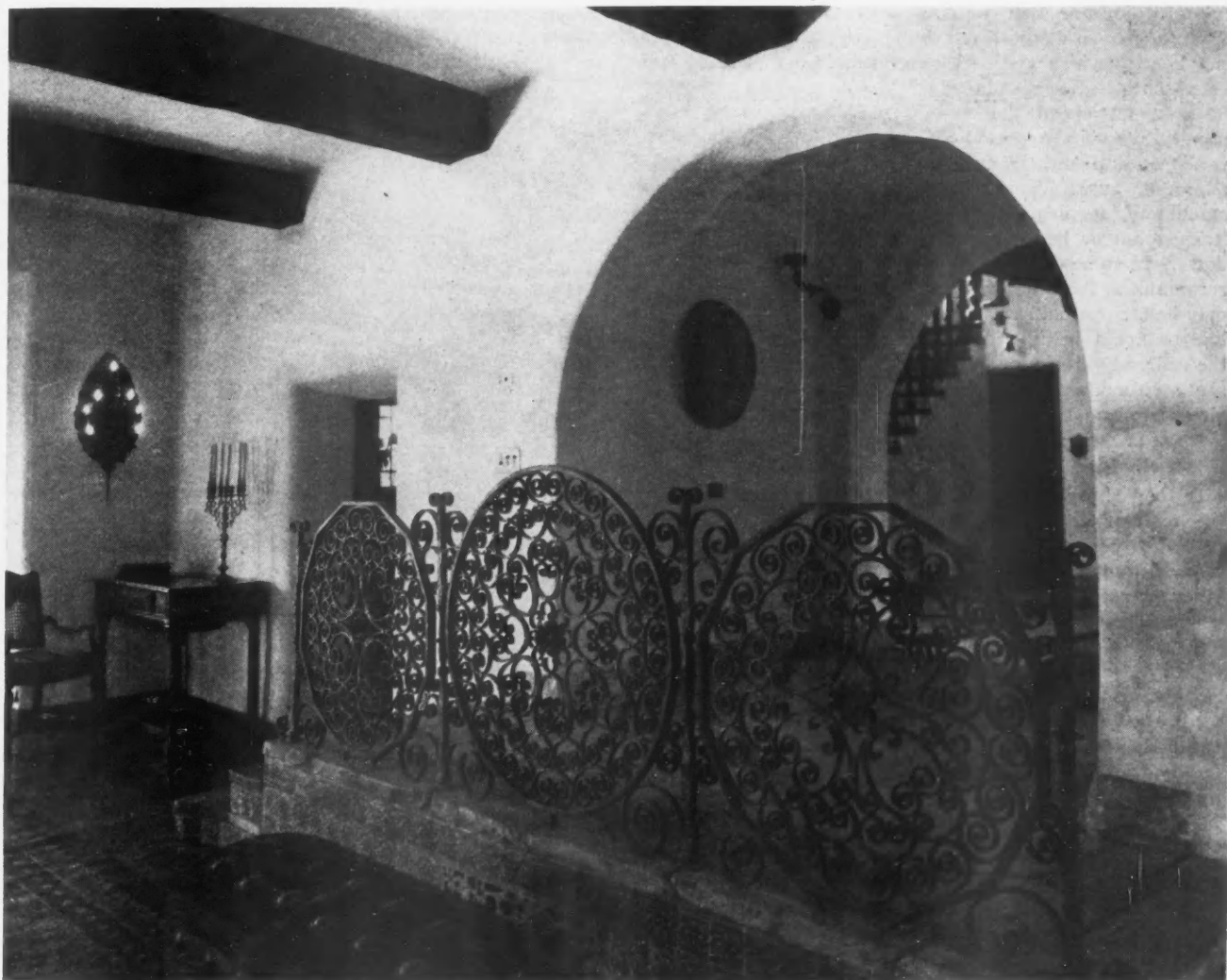
For draperies, the rich velvets and satins are always good, and a scalloped valance gives the Moorish effect. Thus sunfast crimson satin, for example, makes attractive overdrapes when edged with gilt braid. Glass curtains being the modern substitute for blinds, Spanish lace in rich ecru or theatrical gauze has the requisite elegance. Cottons colorfully striped and printed are also being used. The Oriental note sounded by striped curtains, which also carry out Indian motifs, if desired, are seen in one of the photos. Imported linens in "Goya" designs are another new idea. This fabric suggests both the famous painter and the Spanish shawls because of the floral scrolls. Jardiniere is another floral linen that is artistic for drapes. Wrought iron curtain rods of course emphasize the period.



The Beautiful Wrought Iron Screen Used Here Is an Excellent Example of the Delightful Effects Possible Through the Intelligent Use of this Material in Decoration. With it are combined, often in the Spanish interior, wrought iron candle sticks and bracket lights.

	<p>LANDSCAPE ARCHITECTURE AND THE HOME</p> <p>A DEPARTMENT CONDUCTED BY</p> <p>F. A. CUSHING SMITH LANDSCAPE ARCHITECT CHICAGO</p>	
---	--	---

# Selecting the Home-Building Site

This Is NUMBER ONE of a Series of Articles

By F. A. CUSHING SMITH, Landscape Architect

**I**N the thrill of planning our first home, we too often forget that this home, which may be the only one which we will build, is to have a permanent setting, a place in the sun, which is different from that of any of its neighbors. Too many of us plan the house first, long before we have decided on the lot upon which it is to be placed. We do not always realize that the direction in which the lot faces, the grade of the lot, the trees and the rock outcrops, the hills and valleys, are all factors which are intimately connected with the kind of a home which we are to build.

Let us imagine that we are about to select such a lot, before we have designed our home. We will choose a general location which would be convenient to our place of business. The location should also be in a section of the community where the prevailing winds do not send the smoke, odors, or gases from nearby manufacturing plants into our living-room or bedroom windows. In some of the smaller communities this smoke factor may be serious; and we would like to avoid being too near the railroad with its noise and soot. Manufacturing plants always reduce the value of a piece of property for residence purposes.

In the vicinity of large cities the matter of transportation to and from our work is of concern to the home owner. When we are so situated that we can have both an automobile and a home, then the country or suburban sections have many advantages. Here we can usually find good educational advantages for our family, well designed churches, a library and other community features which will give to our children surroundings which they can happily remember, and perchance come back to when their schooling is over.

We expect, and that rightly, a good clear water supply, a well-managed and carefully designed sewerage disposal and refuse disposal system.

We need well-lighted and adequately policed streets, with paving smooth and safe for driving. We may have parks, playgrounds or perhaps a fine bathing beach if near a lake or river.

We have now disposed of the question of where we would like to live, and our next thought is of the lot upon which we will build this dream-home. Where the country is flat, little can be done except in the style and design of the house, to relieve it of monotony. We can by grading, if it be properly directed by real imagination, re-create a new scene about the house.

We can look for trees upon such a lot, trees whose welcome shade and spreading limbs give shelter and a feeling of permanency to the finally completed home. We may be fortunate enough to have several different varieties of trees on our lot, and their preservation should be no small matter of concern to you, their owner. Too many trees, however much we may admire them, only make our home dark and damp, and must be sacrificed in the beginning, before we grow too attached to them.

Some communities take great pride in the trees with which they have been blessed, and take great pains to preserve them. Many of these old forest monarchs have an interesting history. There is an old elm in Cambridge underneath whose spreading branches General Washington took command of his troops. There are elms, the branches of which have been bent in youth at right angle to their trunk, to mark the line of the Indian trails, as they wound their way toward the north lakes.

Our lot should not be too low in grade, so that there is a tendency of the surface drainage, the rains and melting snow of spring, to flow into our cellar, or to make of our entire lot a wet, unhealthy place in which to live. The

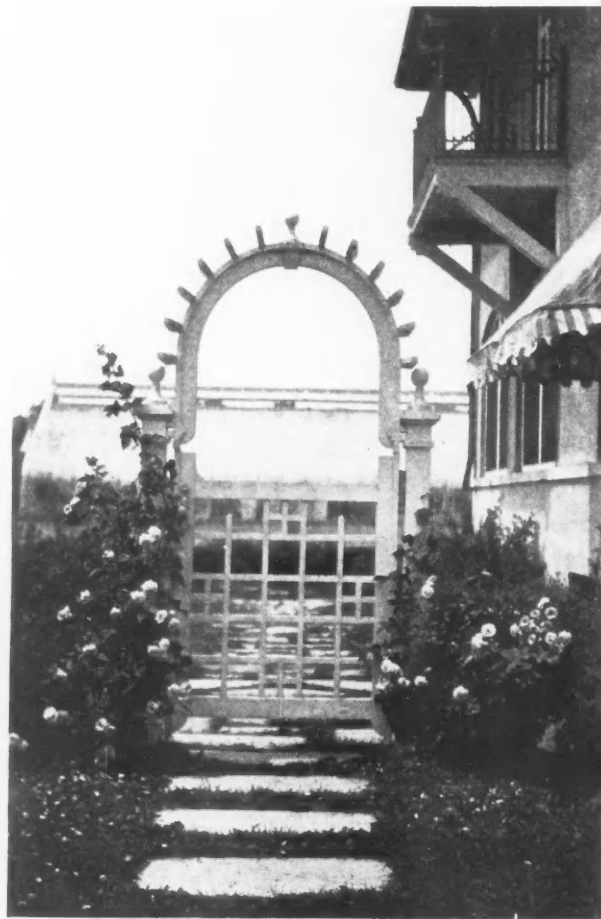

This Terraced Entrance to the Flower Garden and Greenhouse Is Most Invitingly Framed with Rose Bushes Which Adds to the Attractiveness of the Home.

low lot may also be difficult to build upon, due to the average shallow depth of the sanitary sewers in the street. It seems to the writer to be wise in the purchase of the lot, to be sure that the first floor grade of your home can be set at such a height that the house need not be put upon stilts, or on high foundations or terraces, to keep the basement level above the sewer grade.

Most of us know that low wet land is apt to be foggy and unhealthful. Pockets of this kind also encourage damage caused by early and late frosts, which may take all of our fruits or late maturing vegetables, or our choice and cherished late asters. In the spring late frosts also ruin many an otherwise promising fruit crop by killing the blossoms. A friend of mine, who lives in the state of Washington, now noted for its fine apples, was asked why he seldom had frost difficulties in the spring when all of his neighbors were losing large sums in frozen blossoms. "That," said he, "is because as an early comer I chose my home-site, and my orchard site with care, on a high level plateau, where the sun beats warmly down even in early spring."

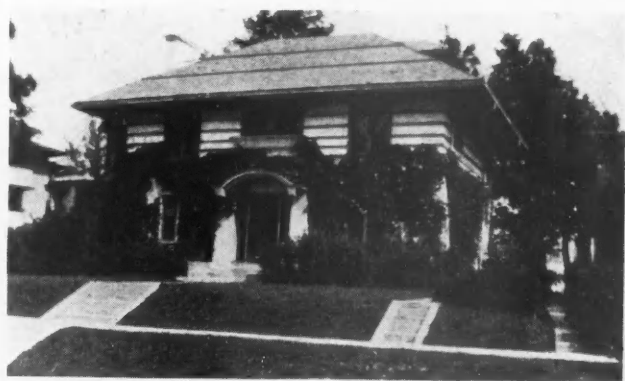

**A Home Built Upon a Terrace, at Some Height Above the Street, Gains Prominence and at the Same Time Improved Views from Its Windows.**

If your lot is high, with a knoll seeming the best place for the house, let the building seem to build up out of the ridge. Do not let it seem to be in danger of sudden displacement during the first wind-storm, perching on the top like a brown derby on a tiny head. Rather, if the hill be high and the house be large let the style be kept low and rambling, with rooms on different levels on the first floor, if necessary, and with terraces of sufficient width to hold the house where it belongs.

A lot with steep slopes to the house and to the garage from the street, is one which may necessitate much grading down to make the ascent an easy and a safe one for either the motor car or for the visitor on foot. This requires no little ingenuity and cleverness in design, but may be the means of giving you an individual final result with the garage placed at a lower level than the first floor grade of the house. The entrance walk may lead upward in long ramps, rather than short flights of steps, until the house terrace or porch is reached.

Another natural feature of great beauty which is an attraction sought by the nature-lover, is a spring-fed brook or a wide lagoon, or a low piece of land with a valley so placed on the lot that it might serve when dammed at the lower end, as a site of a lake where summer swimming can be enjoyed, and where skating in winter gives zest to the



**A Natural Feature of Great Beauty May Be a Spring Fed Brook or Pond. Here mirrored rhododendrons and willows frame the charming view of this country home.**

day's joys. A more inviting scene, nor one more restful, can scarce be imagined.

As long as there is some motion to the water, even though the stream be artificially fed during a part of the day, little danger need be expected from mosquitoes, those pests of the summer evenings. Fish life would keep down the larvae, and provide much happiness to the small boys of the neighborhood. The reflection in the depths of the lake of the flowering shrubs along the banks, of the sunset glow, and of the warm light in the windows of the home you love, is a sight which pulls the heart-strings.

In digging the excavation for the basement of his home, a friend of mine found two large boulders of granite of brilliant hues, which his contractor advised be buried to get them out of the way. Both these rocks were saved. One was made the center,—and a popular center it was,—for a bird-garden and wild retreat, where in its hollowed top the old rock held cool water for the feathered visitors through the hot summer days.

The other boulder, even larger than its fellow was dragged within the shade of an old hemlock. Its rather irregular top was cut into a rustic seat, from the enveloping arms of which on many a summer evening weird tales were told around a crackling camp-fire at its base. Thus unexpected beauties and joys may be found on even a dismal and ordinary appearing site, if we have imagination and the courage to apply it to our lot.

Think in the beginning of the views of your new home which to you seem the most inviting, and frame them with attractive planting. Screen the views which are unattractive, especially those sections which are devoted to the service portion, the drying yard and other unsightly portions of the lot. These screens may be walls, lattice, or planting as has been suggested. Remember that in our northern climate many months are spent within the cozy walls of our home, and thus the best of the views from the windows can be framed, emphasized, and made restful and inviting. Evergreens and architectural features aid in making less bleak the winter's scenery.

Adapt your new home to the site which you have chosen. Adapt the arrangement of the rooms, their size and contents, to both the lot exposures and to the needs of your family. Adapt the materials of construction to those in common use in the community, preferably as permanent as possible. Do not select a freakish style of architecture just to be different from your neighbor. Above all adapt your home and its contents to your pocketbook, so that its final purchase, interest on your investment, taxes, and other fixed and seemingly inescapable charges will not take all of the pleasure out of the ownership of your dream-house.



# Egyptian Theatre, Portland, Oregon, Built in 90 Days

Efficiency in Planning Causes Construction Work to Speed

Designed by EDWARD A. MILLER—Contributed by NAOMI SWETT

**A** NOVELTY motion picture playhouse seating 1,200 people, and in which are incorporated many of the most modern audience comfort and screening appliances, built completely in ninety days, was the construction speed record attained in the building of Graeper's Egyptian Theater in Portland, Ore. The feat is all the more remarkable when it is considered that the building of five modern stores on the property, which is 126 by 145, was part of the job, of which the total cost was \$82,000.

Just fourscore days and ten after starting work the Carlson Construction Company, contractors, had the job ready for the decorators. Careful planning, strict adherence to schedule and close co-operation with the architect, Edward A. Miller, made this achievement possible, with a construction crew, which, even at the peak of operations, never numbered more than forty men.

An interesting feature of the building operations was that the entire balcony of the theater, columns and all structural portions, were completed in a single day. The workers began operations at six o'clock in the morning, and by nine o'clock that night, just fifteen hours later, the cement finishers walked off the job with their work complete. The outside roof, even to the steel trusses, was finished with equal speed, the structural men working just ahead of the cement gang. The steel men began work on the roof of the building on a Friday morning and by 1:30 a.m. the next day they had completed their task, then the concrete crew following up pouring and finishing, with the result that the roof was completely finished by the time the noon whistle blew that day. In a day and a half 8,800 square feet of concrete had been spread on the roof,



Graeper's Egyptian Theater Shows a Splendid Harmony of Beauty and Utility and Incorporates a Number of Unusual Features. Its speed of construction is a fine example of what can be accomplished by thorough planning of every operation.

including the placing of the roof slab steel. Other portions of the building were completed with equal speed.

Under the ordinary method of roof construction it would have taken between three and four weeks to do this piece of work, where wooden forms would have been hung from the trusses with the necessary forms for concrete purlins, slabs, etc. This procedure was avoided by using steel joists self-centering 2½-inch slab and pouring direct on the self-centering, which enabled the builders to lessen the

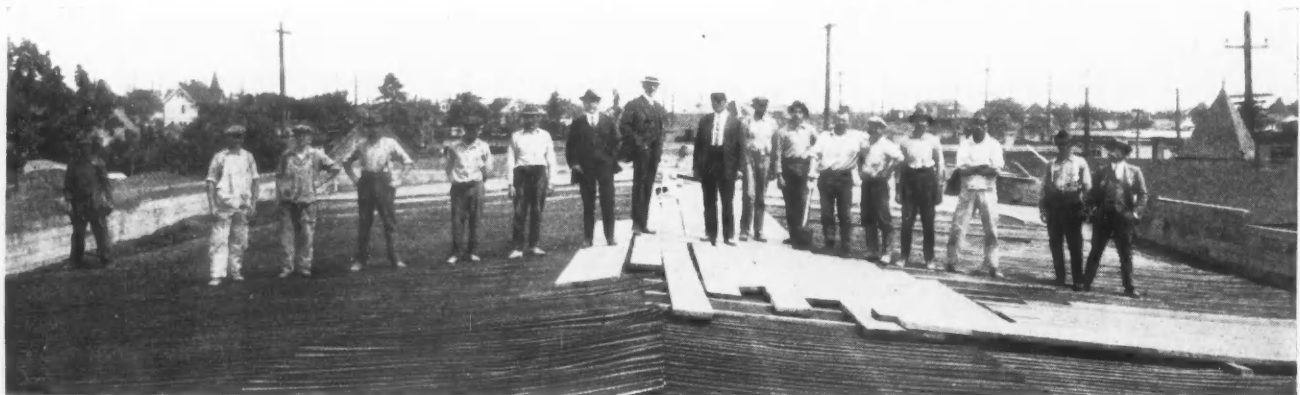

Steel Men Started Work on the Roof of the Egyptian Theatre on Friday Morning at 10:30 A. M. and the Next Day Had Completed Their Work. They were followed by the concrete crew and by noon Saturday, in a day and a half of work, the entire roof, including 8,800 square feet of concrete, was finished.



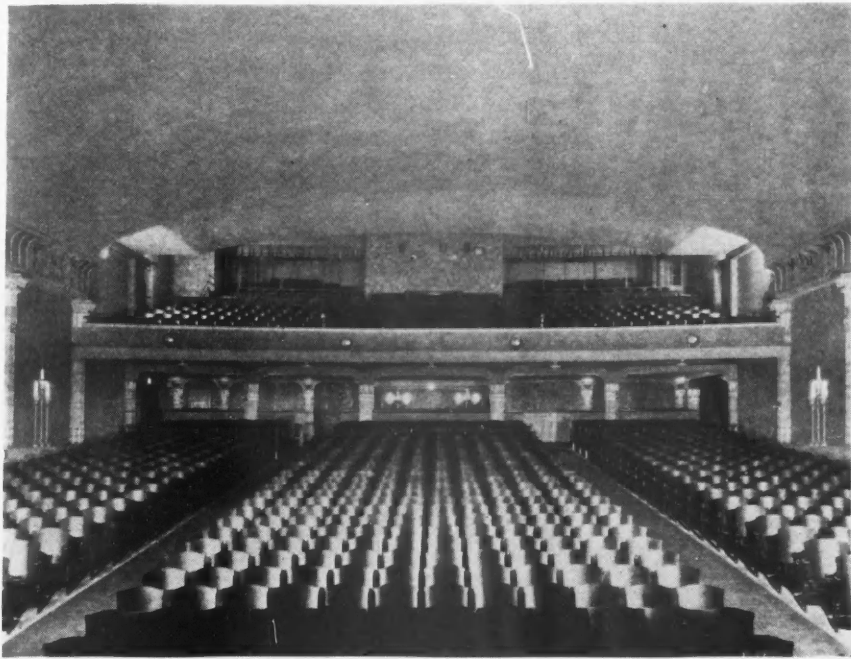

dead load on the trusses. The result was that the trusses, columns and footings were lightened, and the suspended ceiling carried direct from the roof slab with heavy wire looped through a self-centering supporting the light steel channels of the dome ceiling, leaving the work ready for the lathing crew to begin operations on the following Monday morning.

From the standpoint of beauty and practical advantages, Mr. Miller, the architect, decided upon the style of building that the ancient Egyptians made famous. The result has been a splendid harmony of art and utility. Graeper's Egyptian Theater is a piece of maximum enjoyment which provides a perfect seating arrangement, perfect acoustics, thermostatic ventilation control and a system of illumination that affords the best screening results with full observation for the patrons.

As the theater is built entirely of

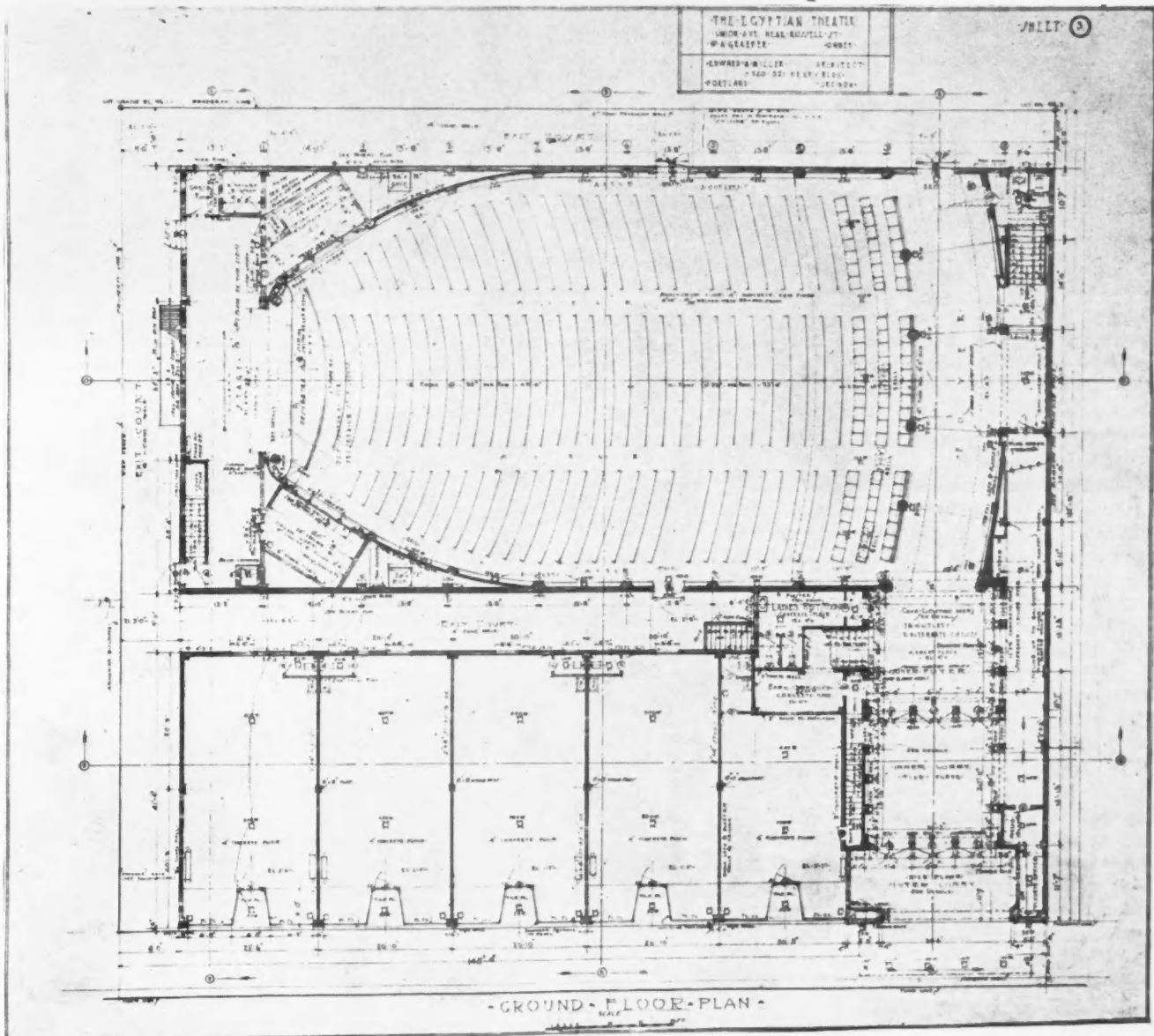

Above: Another Interesting Example of Rapid Construction Is the Balcony of the Egyptian Theatre, All Structural Portions of Which Were Completed in a Single Day. The workers began operations at six in the morning and were through at nine in the evening. Below: The floor plan shows the elongated horseshoe shape of the auditorium which obviates all square pockets.

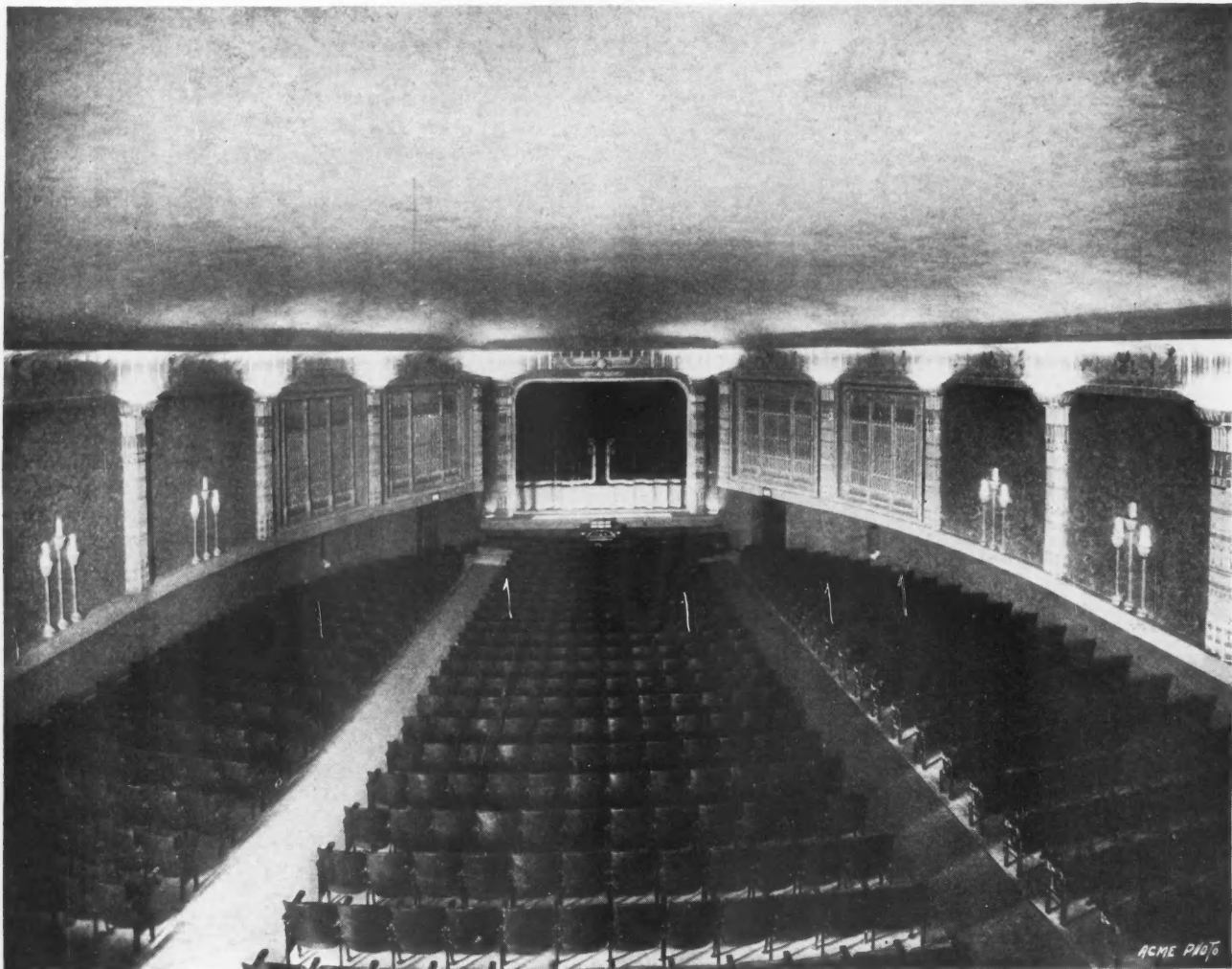

The Auditorium of the Egyptian Theatre Has a Ceiling Shaped Like an Inverted Eggshell Which Affords the Most Satisfactory Acoustics. The lighting is such that a person may see about the house during the performance and yet be screened from the discomfort of any direct glare.

reinforced concrete with an all-steel and concrete roof, it is completely fire-proof. The auditorium has the shape of an elongated horseshoe. Square pockets have thereby been obviated and all surplus space has been taken up by the two organ chambers and the ventilation shafts. The area of the organ chambers is 15 by 10, and they are 12 feet high. Access to the sound chambers is gained through metal doors in the right and left wings of the stage. The organ is a Wurlitzer Hope-Jones Unit orchestra of the most modern design, installed at a cost of \$18,000.

The ceiling of the auditorium is shaped like the inverted half of an eggshell and therefore contains no angles, sides, tops or ends, thus affording the most satisfactory acoustics. The walls, floors and ceiling of this theater are of solid concrete plastered smooth. Five exits lead to an alley and on the main auditorium there is a seating capacity of 866 persons.

The balcony is approachable by an easy incline from the foyer, which is 6 feet 6 inches in width. There is additional access to the balcony by two

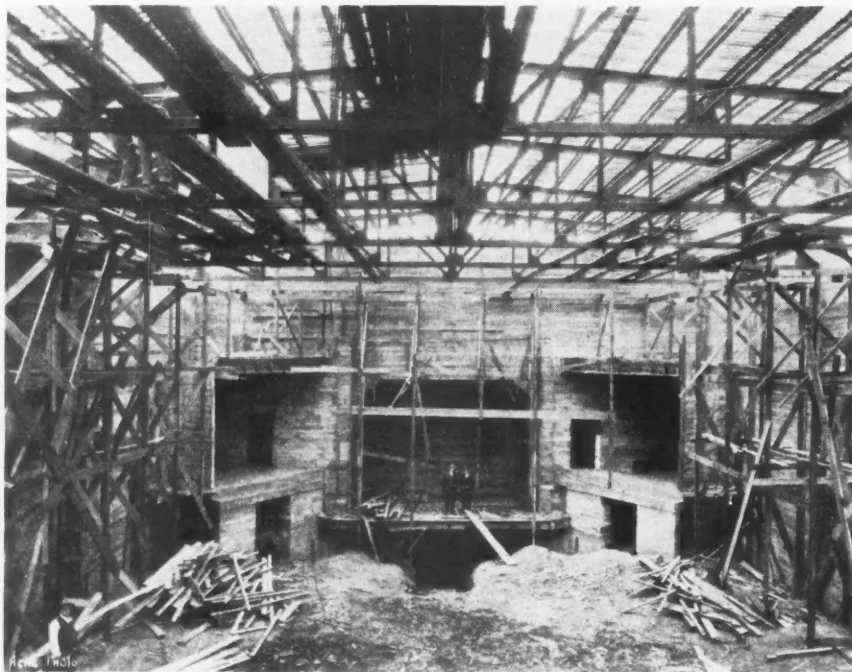

Here Is a View of the Stage in the Course of Construction. The rapid construction work was accomplished with a crew that never numbered more than forty men, even at the peak of operations.



The Spacious Lobby of the Egyptian Theatre Is Decorated in Blue, Gold and Autumn Colors Which Blend in a Most Pleasing Harmony.

6-foot staircases. An easy angle, well back from the screen, gives ideal vision from the balcony seatings. This part of the house, which is a decided innovation in concrete construction is supported by four big reinforced concrete cantilever beams. There is an overhang of 18 feet which obviates the necessity of supporting columns beneath, and the following obstruction to the view of the people seated back of them. There is a seating accommodation of 334 persons in the balcony.

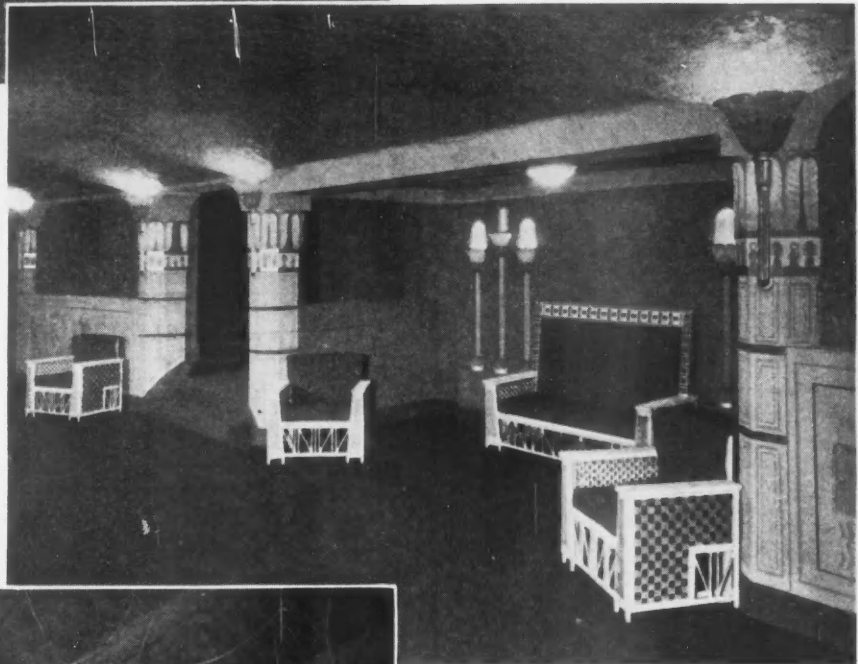

The Ancient Egyptian Style Was Adopted as a Model and the Result Is Entirely Satisfactory, Both from the Standpoint of Beauty and Practical Advantages.

of fireproof construction and thermostatic control makes it possible for a complete change of 96,000 cubic feet of fresh air every three minutes. Oil fuel is used for heating purposes, giving a comfortable degree of warmth at all times. Heating and ventilation was designed by Jay H. Keller, heating engineer, while the heating and plumbing fixtures were installed by Fox & Co., both firms of Portland.

The theater is approached by a spacious lobby. Plate glass doors divide it from the outer foyer, which in turn is separated from the foyer proper by a set of doors of identical material. The main foyer is 65 feet long and 15 feet wide. Near the balcony is a place for parking baby car-

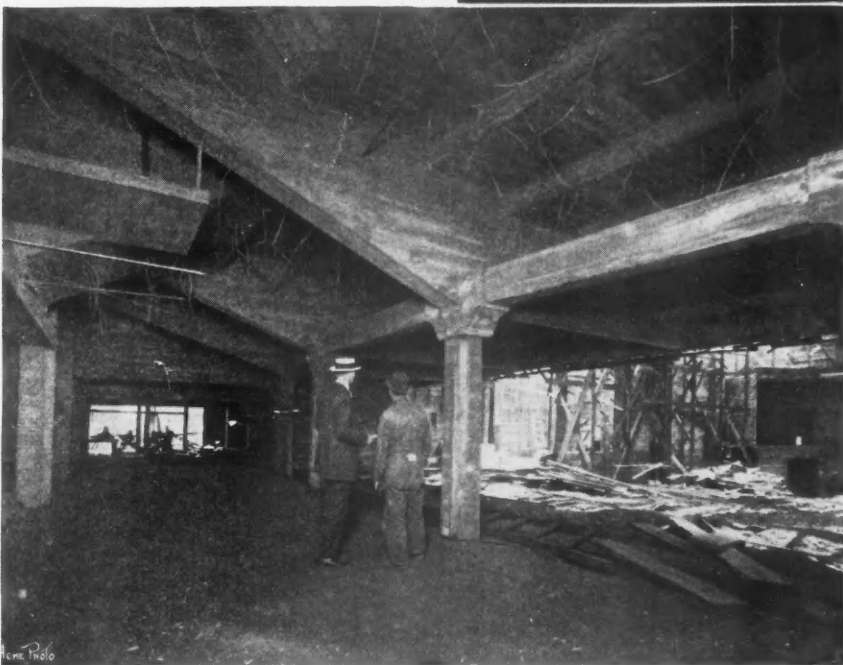

Another Detail of Construction Showing How the Balcony Is Supported by Reinforced Concrete Cantilever Beams, with an Overhang of 18 Feet Which Obviates the Necessity of Supporting Columns Beneath.



riages, a check room and the ladies' rest rooms, while at the far end are the men's toilets. On either side of the orchestra pit are lavatory facilities for boys and girls, and adjacent to these points, in the side aisles, drinking fountains. On a mezzanine floor on the balcony level are the ladies' rest rooms proper and a reception room. The manager's office, which is situated in the front part of the building, affords a complete view of the lobby at all times, and connects with all parts of the house. The seats and stage curtain, as well as the decorations were installed by Shearer & Co., of Seattle, Wash.

Of particular interest is the system of illumination in the Egyptian Theatre. The lighting arrangement is such that a person may see about the house easily during a performance and at the same time not be discomfited by having the screening of the picture injured in the slightest degree. None of the usual electric lighting fixtures are in view, as illumination is afforded mostly by the indirect method, which imparts a soft glow very pleasing with the blue, and autumn-colored bronze ornamentations. The rough plaster finish walls have the appearance of golden tapestry. NePage McKenny Company performed all wiring, while the

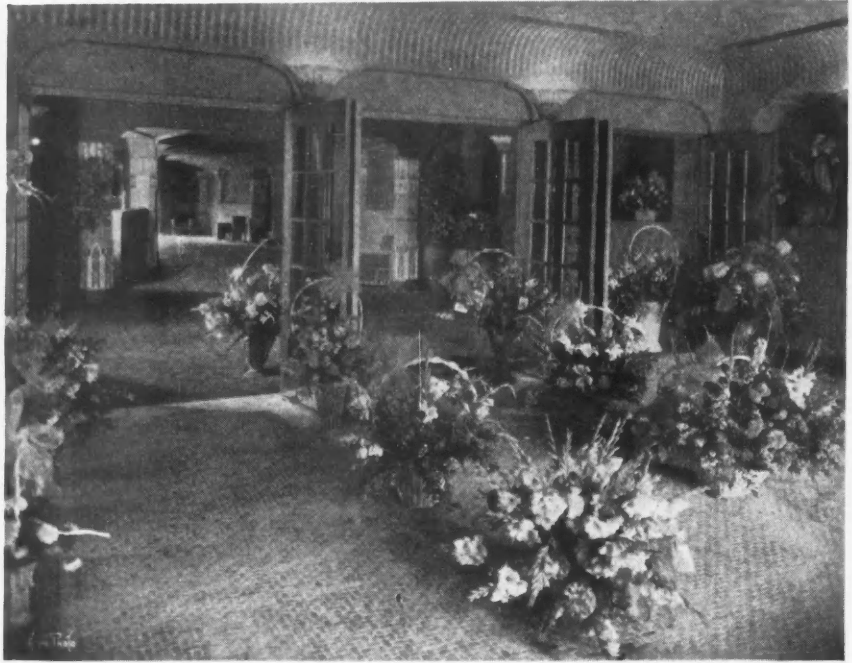

Another View of the Lobby of the Egyptian Theatre Profusely Decorated with Flowers to Welcome the Earliest Visitors to This Beautiful Place of Entertainment.

David L. Hoggan Company were responsible for the exceptionally fine plaster work in this very interesting motion picture theatre.

## A Place of Business Which Fits Its Setting

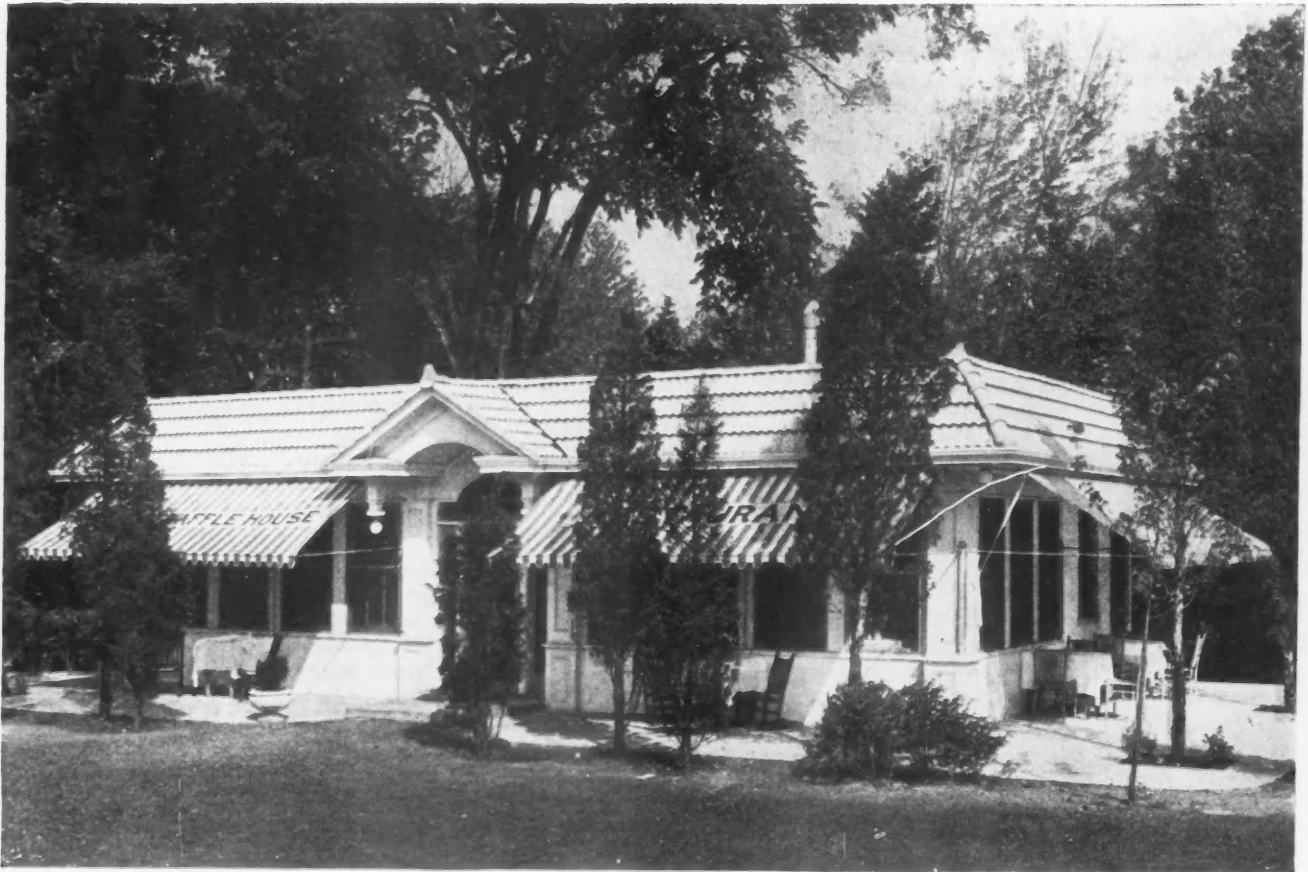

Beauty Is an Asset in Business Buildings as Well as in Homes. Here is an example of what may be done to make a restaurant, or for that matter any place of business in parks or with a natural setting of trees, a pleasing part of its surroundings. Awnings, shrubbery, and well placed trees invite the passerby to stop and become a patron.



# Littleton's Model Small Library

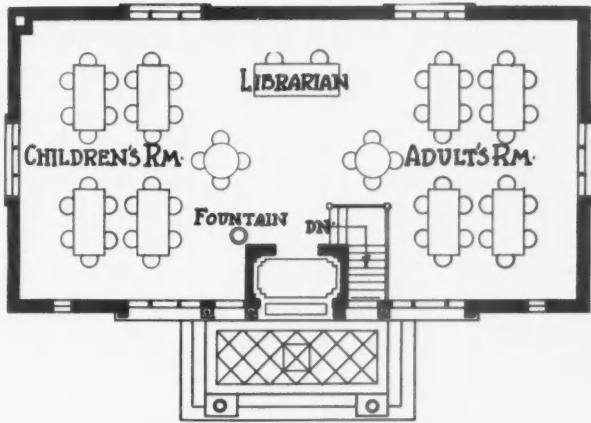

The Floor Plan, of Course, Is Simple, but the Arrangement It Well Adapted to Service the Intended Purpose.

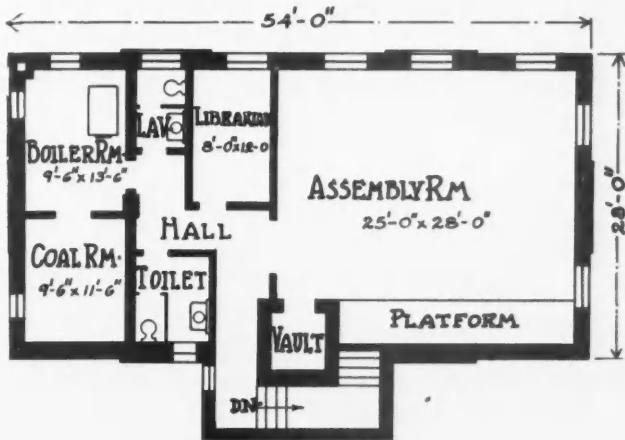

That Part of the Basement Which Is Not Required for Coal and Boiler Rooms, Toilets and Librarian's Office, Is Well Utilized as an Assembly Room.

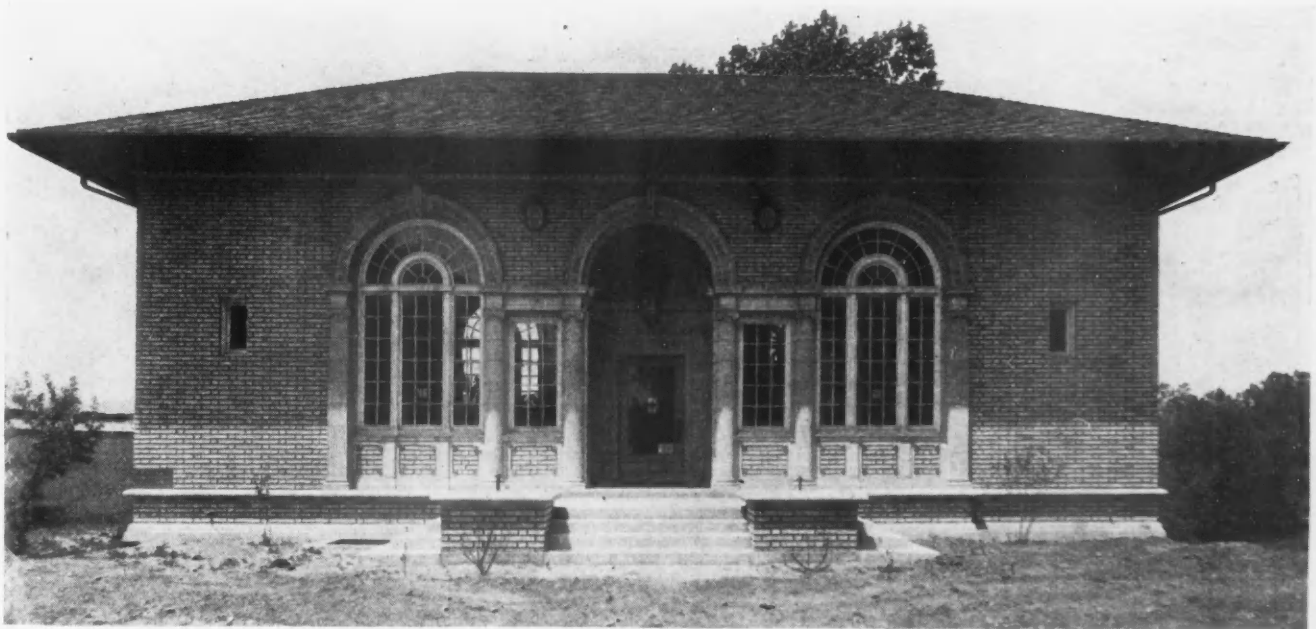
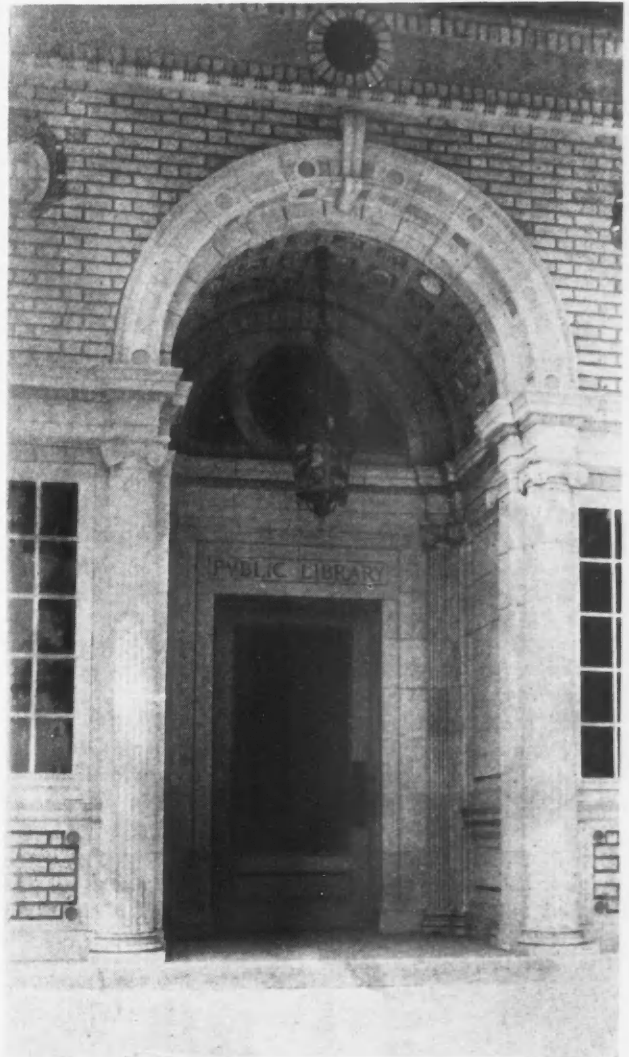

Even the Small Town May Have a Library Building to Be Proud of. Littleton, Colo., a village of 1,500 population, built this library at a cost of \$8,000. It is a fine example of what can be done on a small scale in combining utility and artistic design in small public buildings. The main entrance, above, is especially worthy of note, carrying an air of dignity without being heavy in proportion to the building as a whole. J. B. Benedict, Denver, Colo., architect.



# HOMES in COLORS

## *Home Building—the Greatest Fun in the World*

By WILLIAM A. RADFORD

*President and Editor-in-Chief  
of American Builder*

Golf is all right.  
And motoring is all right.  
But say, for downright joy and satisfaction just try home building!

You begin this game by studying plan books and snooping around into every new house you see going up. Very likely you start a scrap book of clippings—each with a different sort of an idea about home planning or building, or decorations, or furnishings.

Then you consult some man in the building business who you think may know more about the technical details than you do. He may be an architect, a builder or a building material dealer, and you find him ready to help and full of enthusiasm for the home building idea.

Good progress is made under the guidance of this friendly advisor and in due course the plans are worked out, all details decided and the big day of breaking ground finally comes.

The game of home building is turning dreams into realities, and there is no keener enjoyment in life than that of

creation. To turn hopes and plans into solid walls and a tight roof, and sunshiny rooms looking out onto a garden is *real creation*—I care not how small the home or how limited in its features.

Then you watch your new home grow! Some days a lot of progress is made; and sometimes when you come onto the job at night, after the workmen have gone home, to check up on what they have been doing, you can hardly find anything new to represent the day's work; yet you know it must be there.

And then finally the house is finished—the builder says "finished" and pulls out, and you get ready to move in.

Then the real fun begins: "*Finished*," you discover, simply means that the stage has been set for YOU to get busy. Cleaning up, grading up, planting, decorating, draperies, here a new rug and there a new piece of furniture—all of these are day-by-day challenges to your energies, your taste and your creative imagination. You get in your friends to help and everyone has a fine time.

Talk about golf for reducing the waistline! Try a 12-inch shovel in mixed clay and loam on the neat little job of building an 18-inch terrace or of fashioning a rock garden!

Home building is the greatest fun in the world; it takes you out into the open air, and then brings you back inside again into real home comfort and satisfaction.



Grand Sport for All—Good Health—Activity—Accomplishment—That's the New Home!



## The Forestville

**A** DUTCH Colonial home of generous size with extra spacious living room and attached sun parlor. The upper floor contains two large bedrooms and two smaller ones. Note the generous provision of bathrooms and lavatories in this plan. A corner of the cheerful sun porch is illustrated in the color sketch and an interesting pergola shelter for a rear porch is presented.

Pat. March 15, 1924 and Sept. 30, 1924. Copyright 1925  
Wm. A. Radford, Chicago.

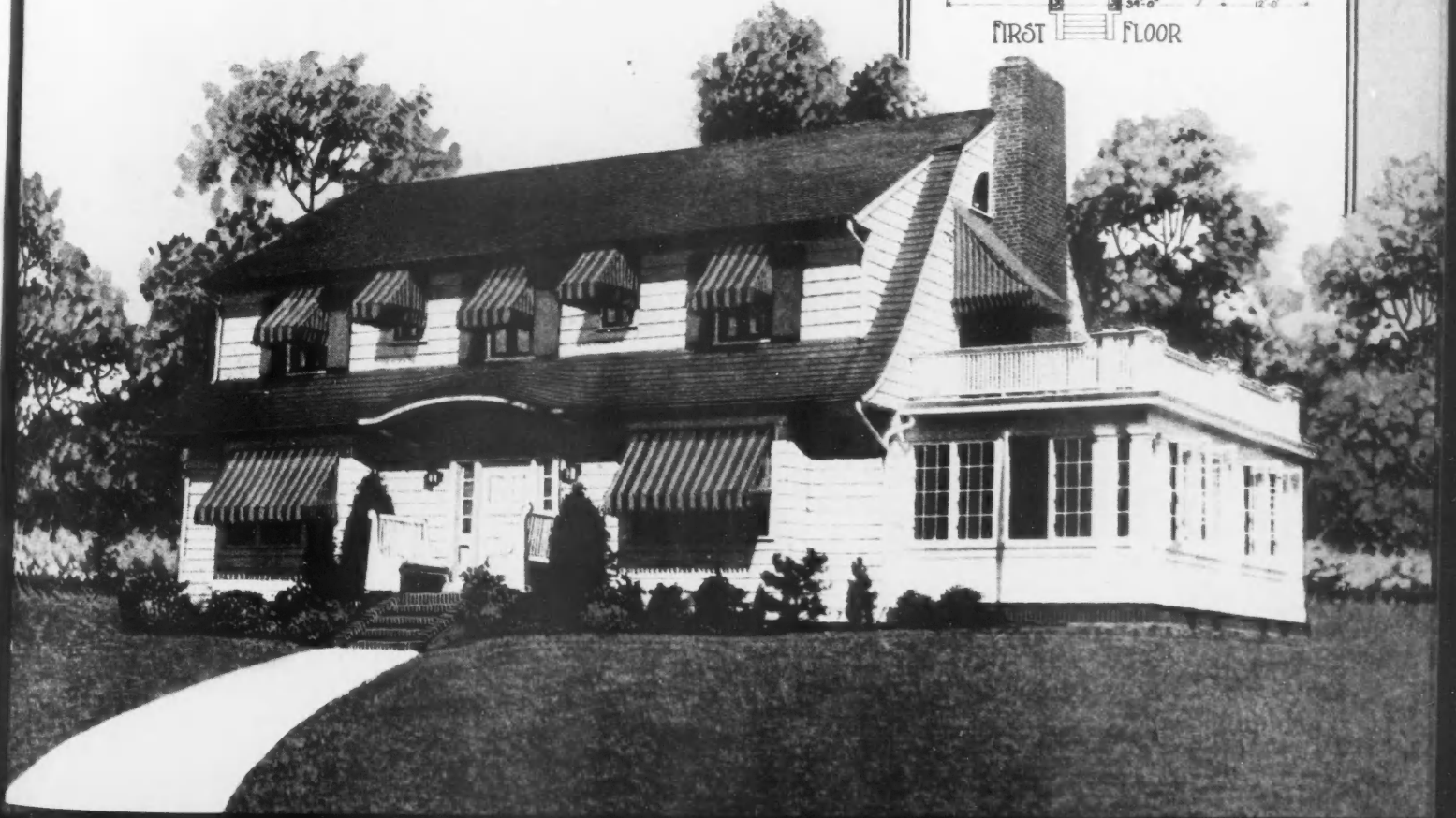
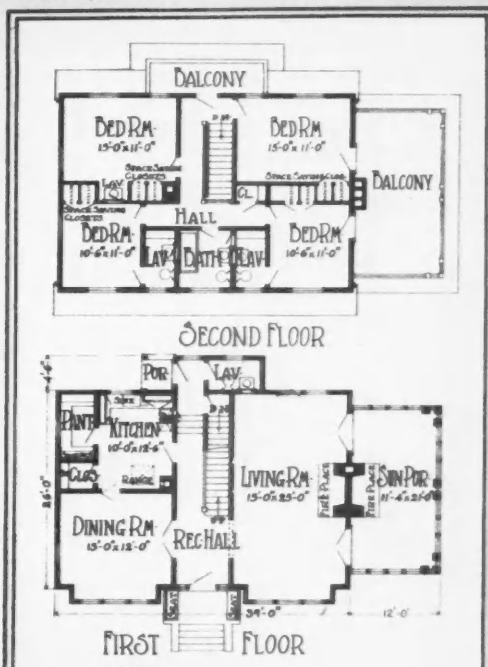



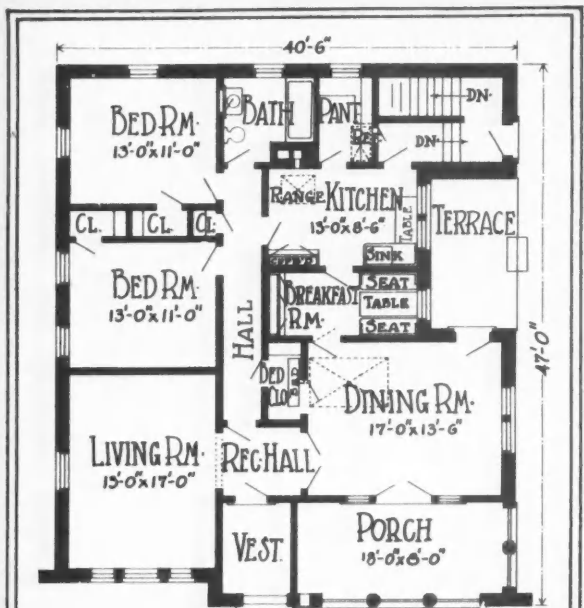
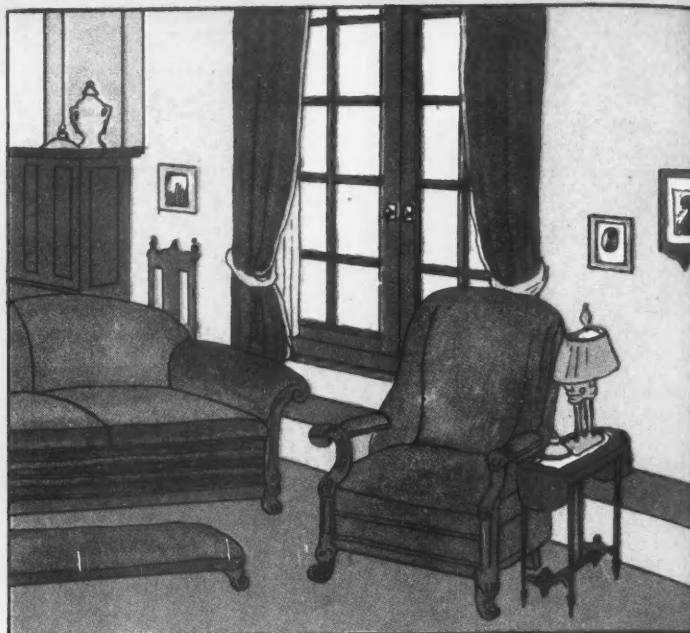
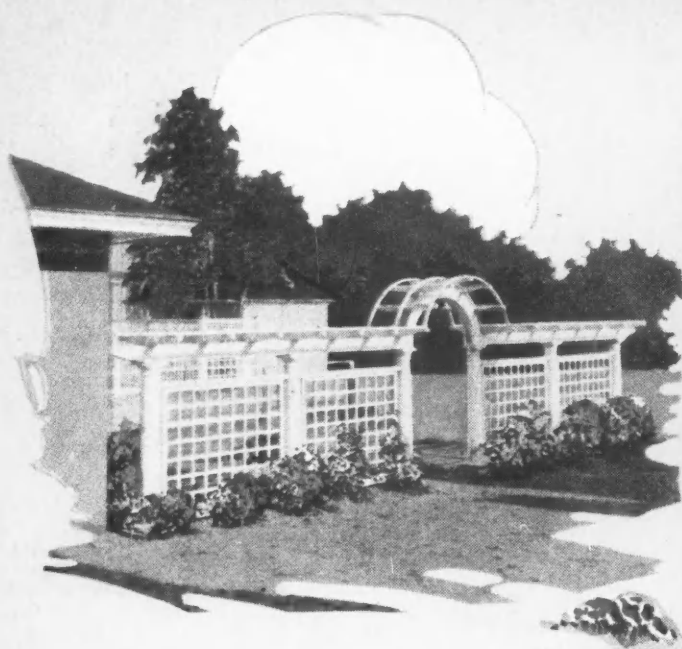

FLOOR PLAN

### The Fontana

A SPANISH design of true southern charm, yet planned to withstand the rigors of a northern climate, is presented in this delightful five-room home. A disappearing bed in the dining room gives this house six-room efficiency and there is also the much favored little breakfast-room very conveniently placed. The color sketch suggests a rich treatment for the living room. An ornamental fence with graceful arch entrance is also presented.



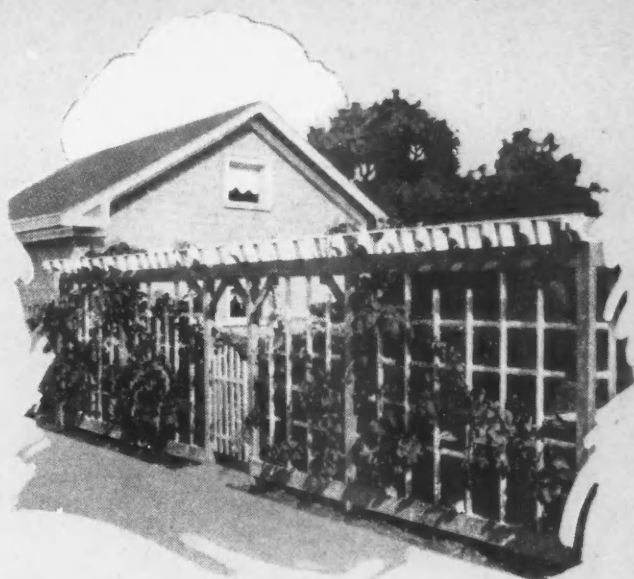
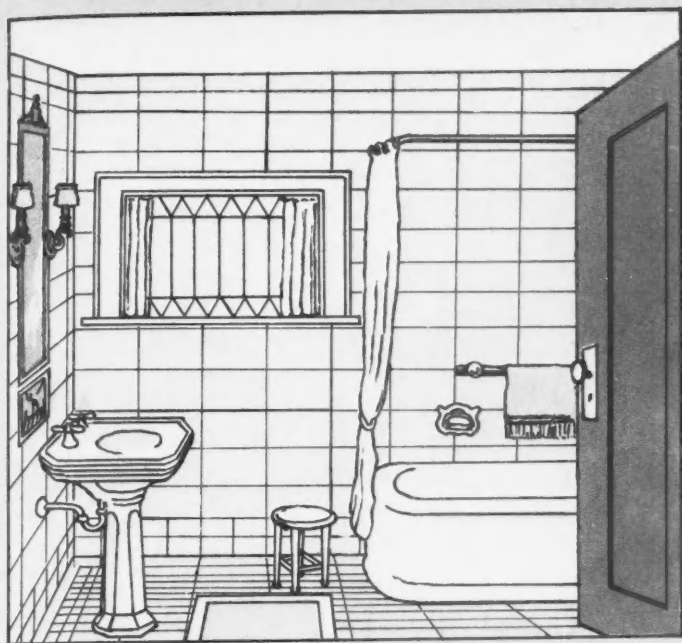

### The Farnham

**A** DELIGHTFUL story-and-a-half bungalow of Colonial lines, yet retaining much of the old-style popular western bungalow flavor. Five rooms are provided on the first floor and three upstairs. Color sketch shows modern bathroom with walls of glass slabs. A very charming grape-vine support with pergola top may unite house and garage as illustrated to the right.

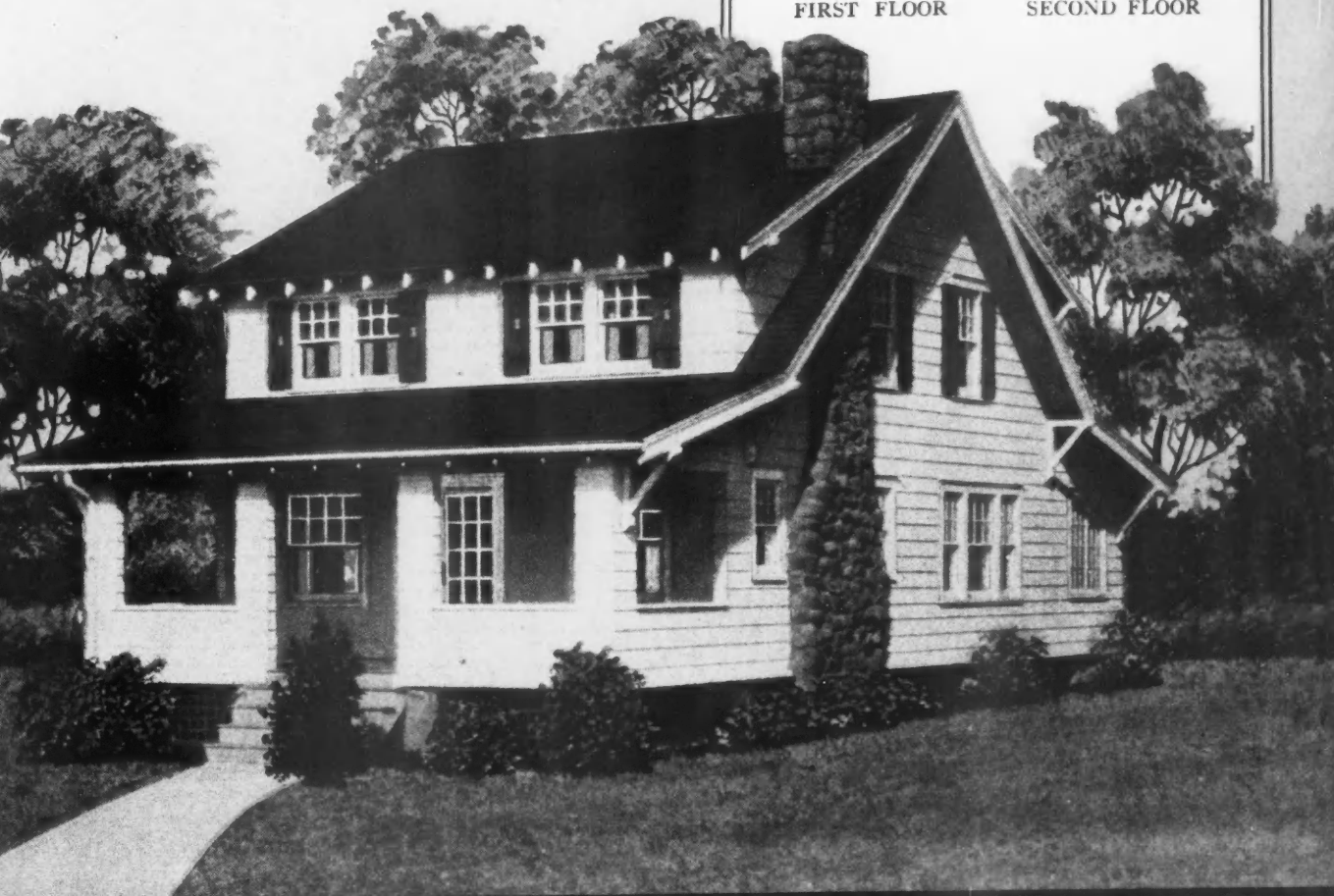
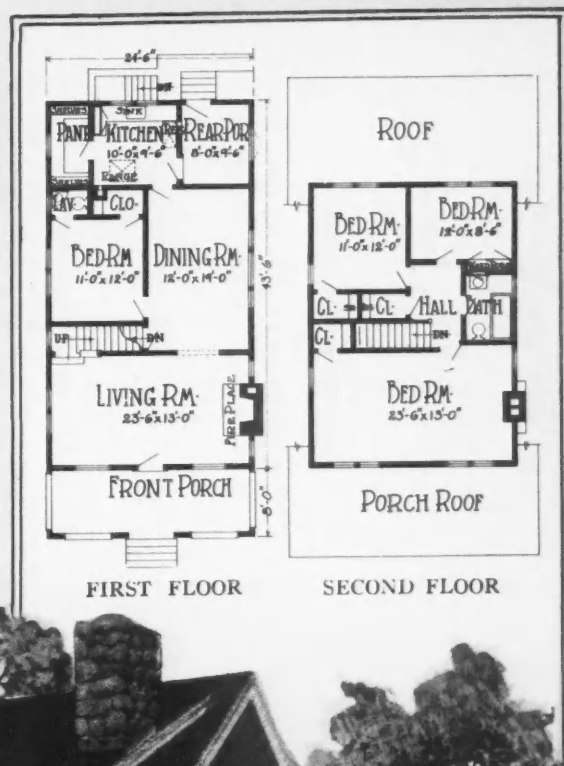



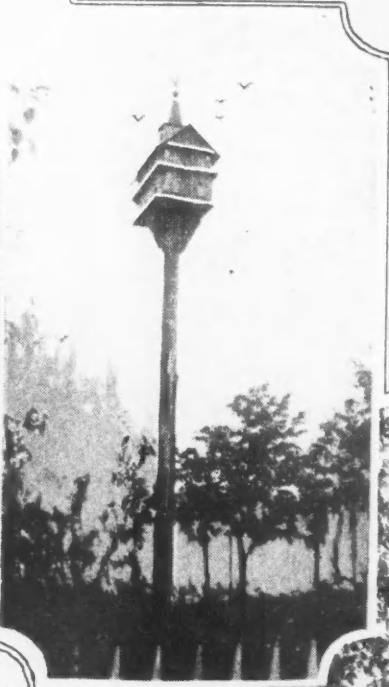
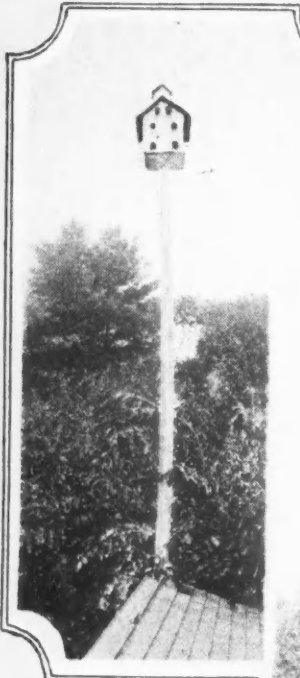
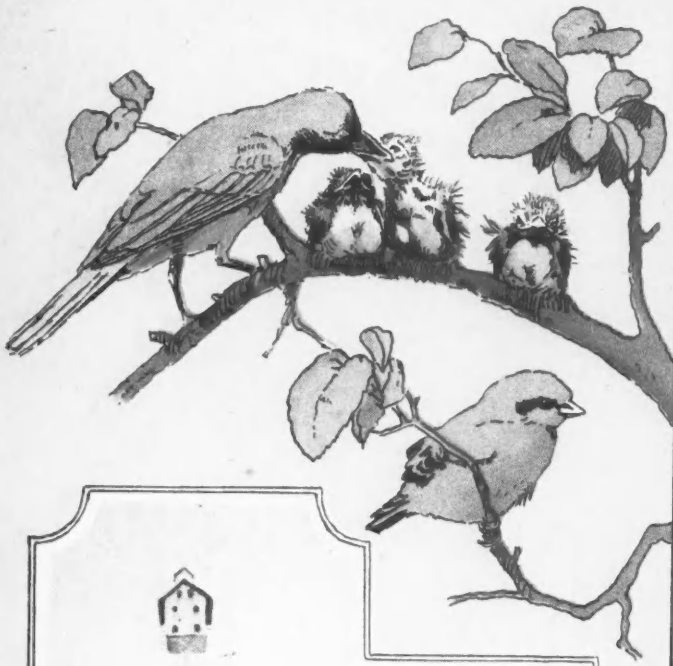

## Homes for

YOU will find the building of bird houses and the methods of attracting birds a most fascinating study. The U. S. Department of Agriculture Bulletin No. 609 says:

"Birds may be gathered about us in all seasons of the year with ease and certainty merely by offering what they desire. In winter they are often pushed for food, and if we supply this need they will report daily at the lunch counter and help to relieve the tedium of our indoor life. In summer they care less for food provided by their human friends, and other means must be sought to attract them about the home. They appreciate fresh water for bathing and

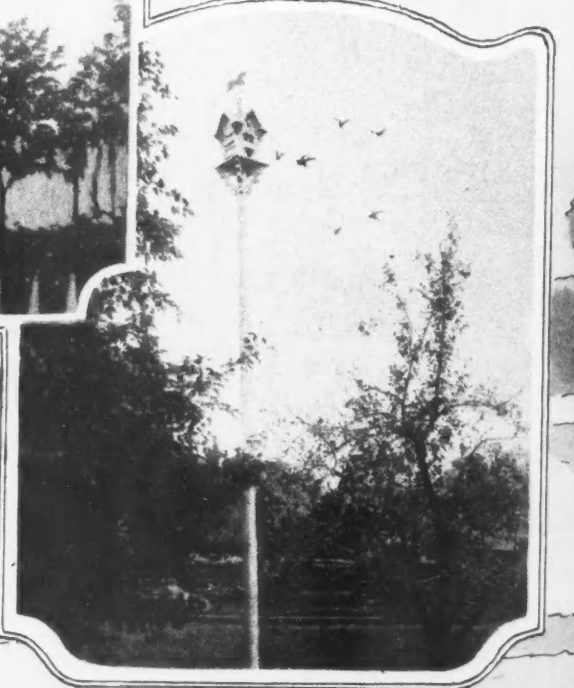



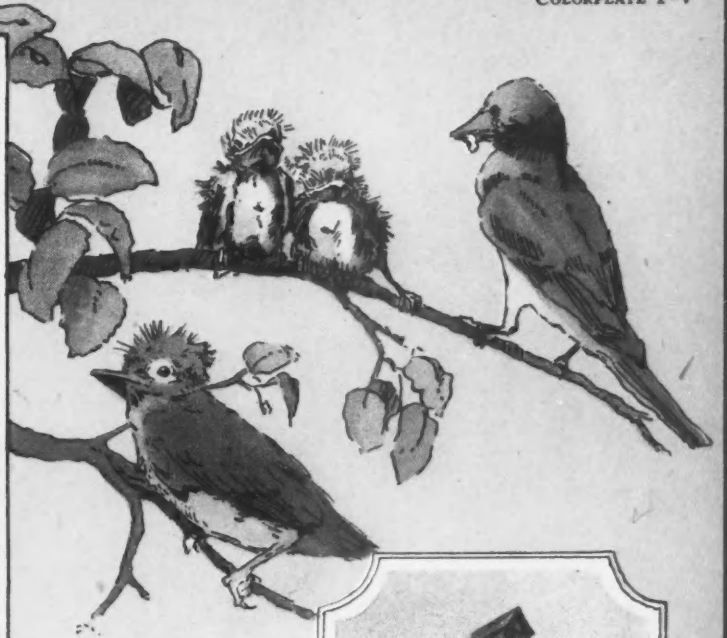
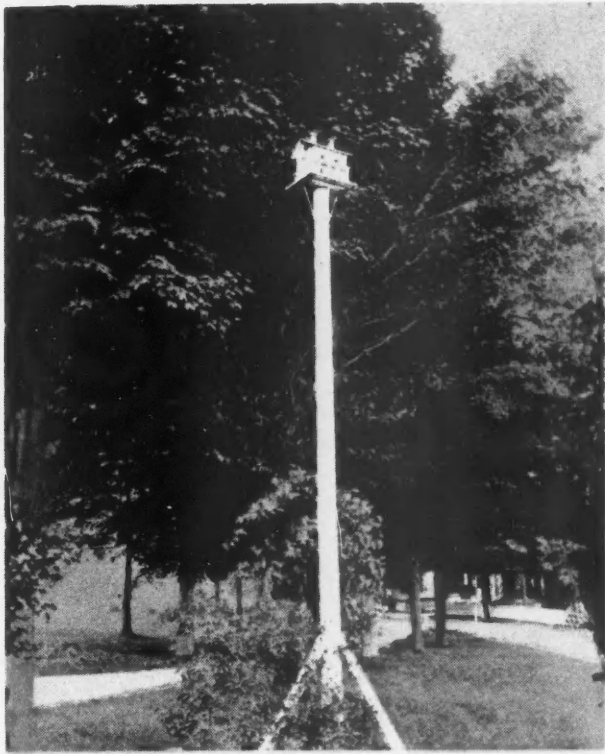

## the Birds

drinking. A shallow pool of varying depth, if only a foot across, becomes on hot days a center of attraction for all the birds in the vicinity. If safe retreats are furnished in which birds can rear their young comfortably, most of them will be occupied. In fact no attraction for summer birds is more effectual than a series of houses suited to the needs and habits of the various kinds of house birds.

"The practice of erecting bird houses in this country, while now nation-wide is not so common and uniformly distributed as it should be, and more extended provisions of this nature can not fail to result in a largely increased number of house birds."

Bird house photos by Mrs. Linn White.

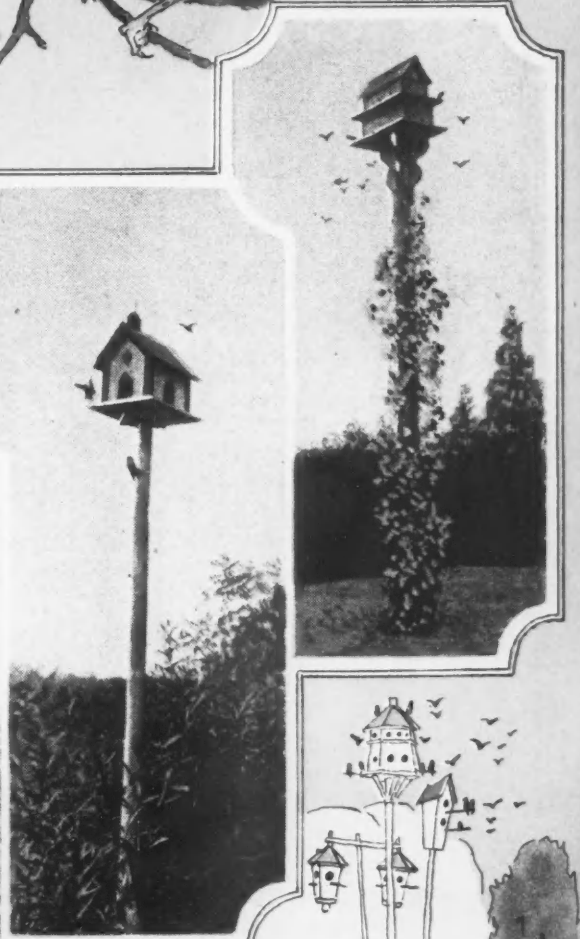

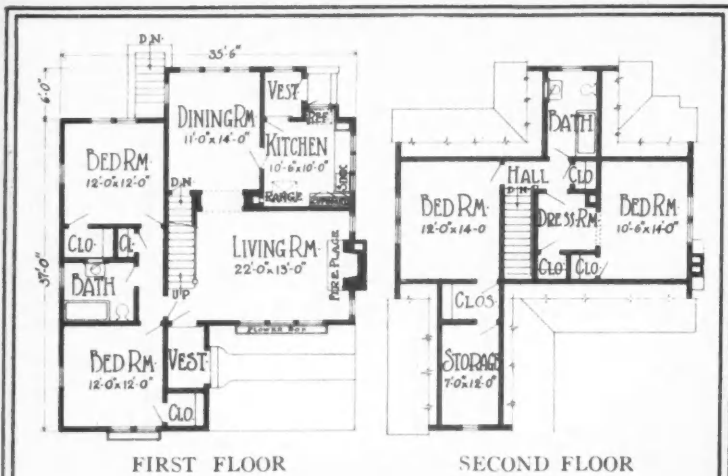
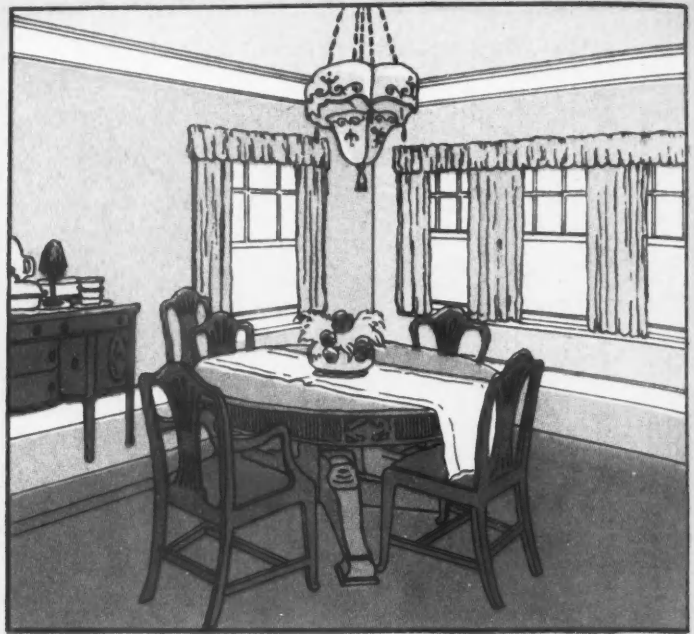
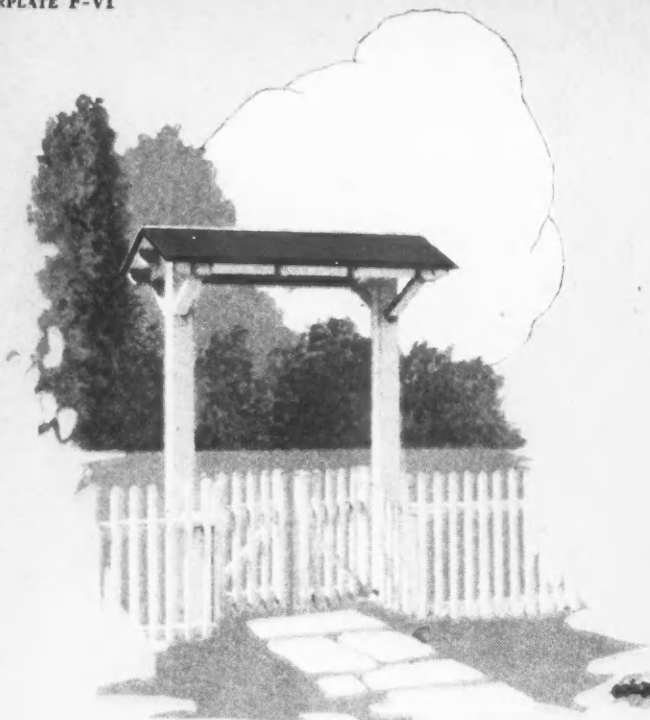

### The Fayette

A DESIGN of delightful French atmosphere containing five rooms on the ground floor besides two bedrooms, bathroom and large storage space up under the roof. Color sketch above suggests an attractive dining room arrangement. To the left is a gateway of character in keeping with this home design.





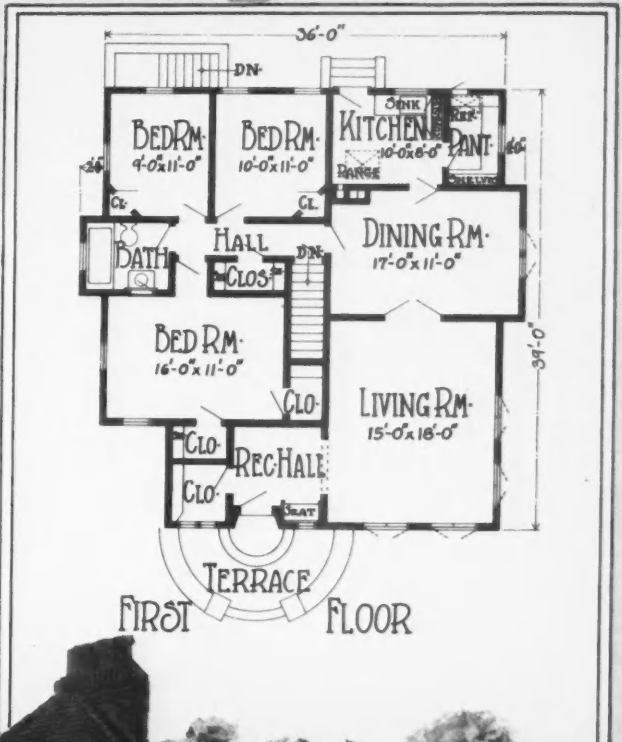
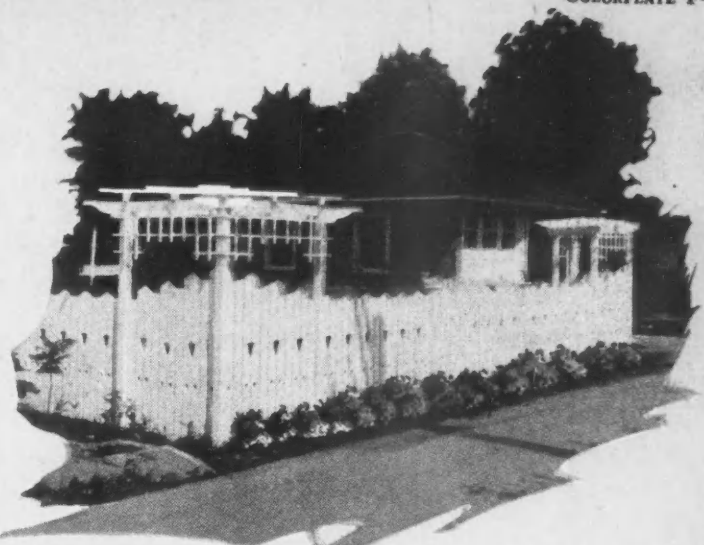
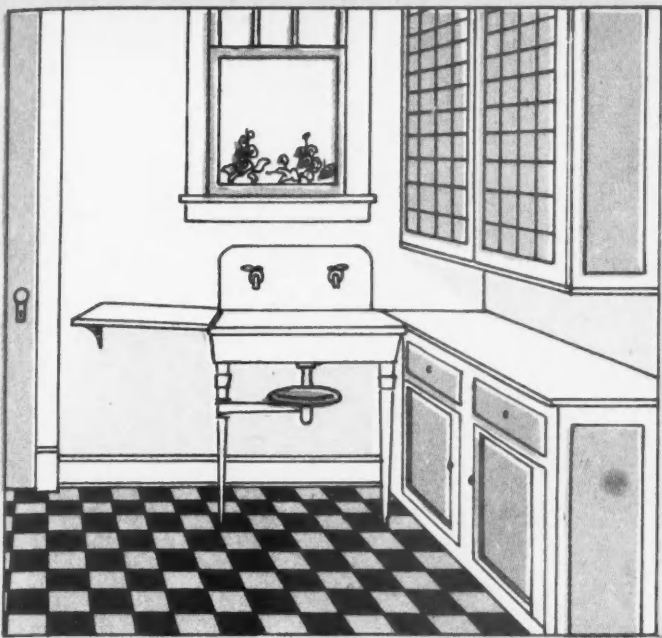

*The Fredonia*

A STUCCO cottage of distinctly foreign flavor containing six well arranged rooms. Color sketch shows efficiency fittings for the modern kitchen. To the right is pictured an attractive ornamental fence with an unusual feature of pergola roofed corners.

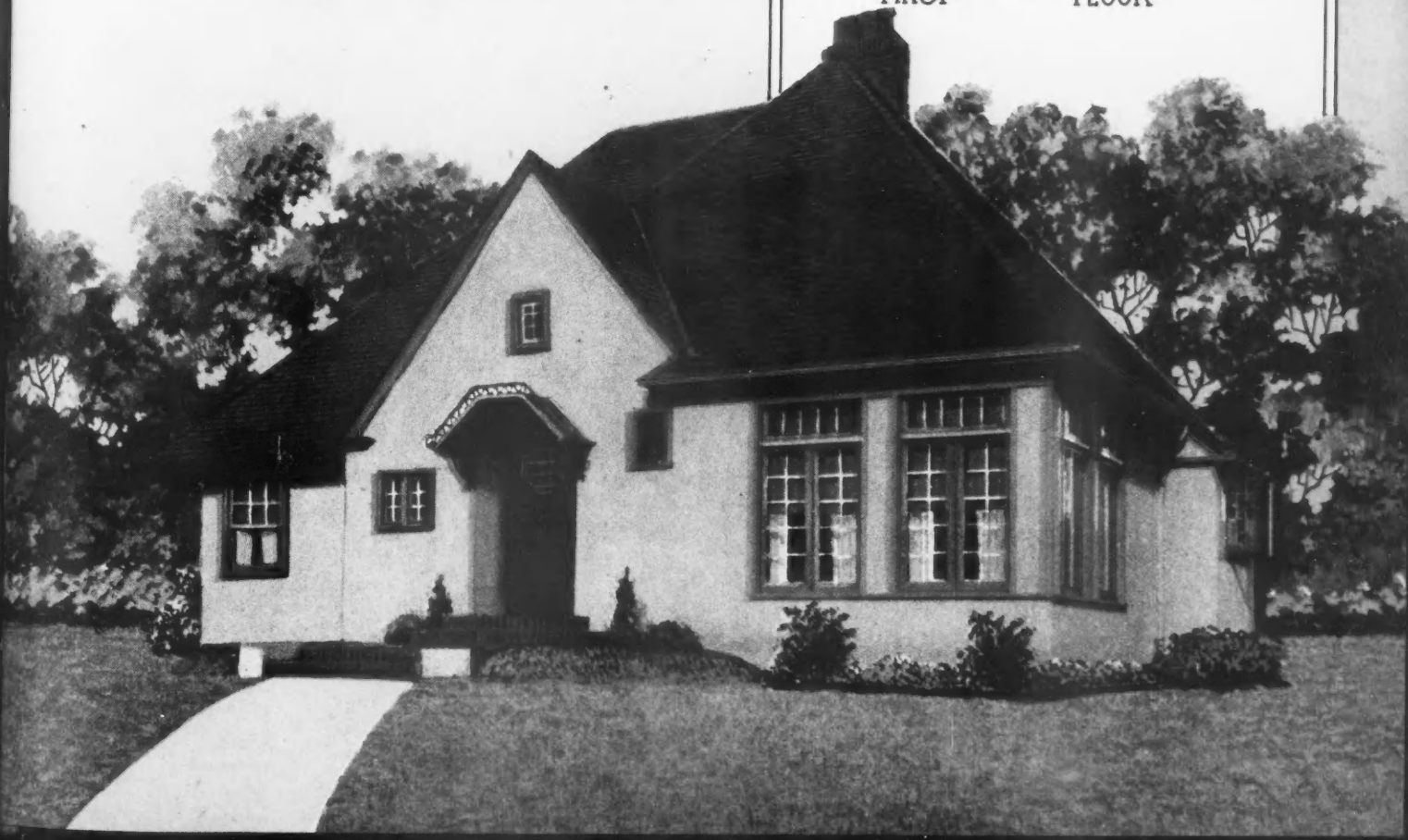



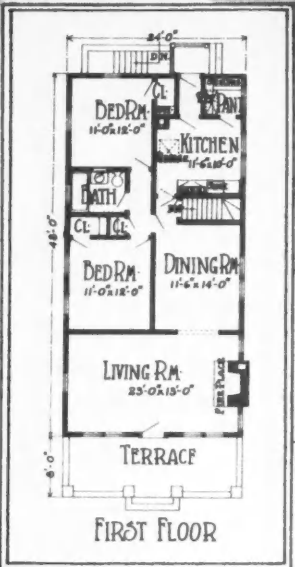
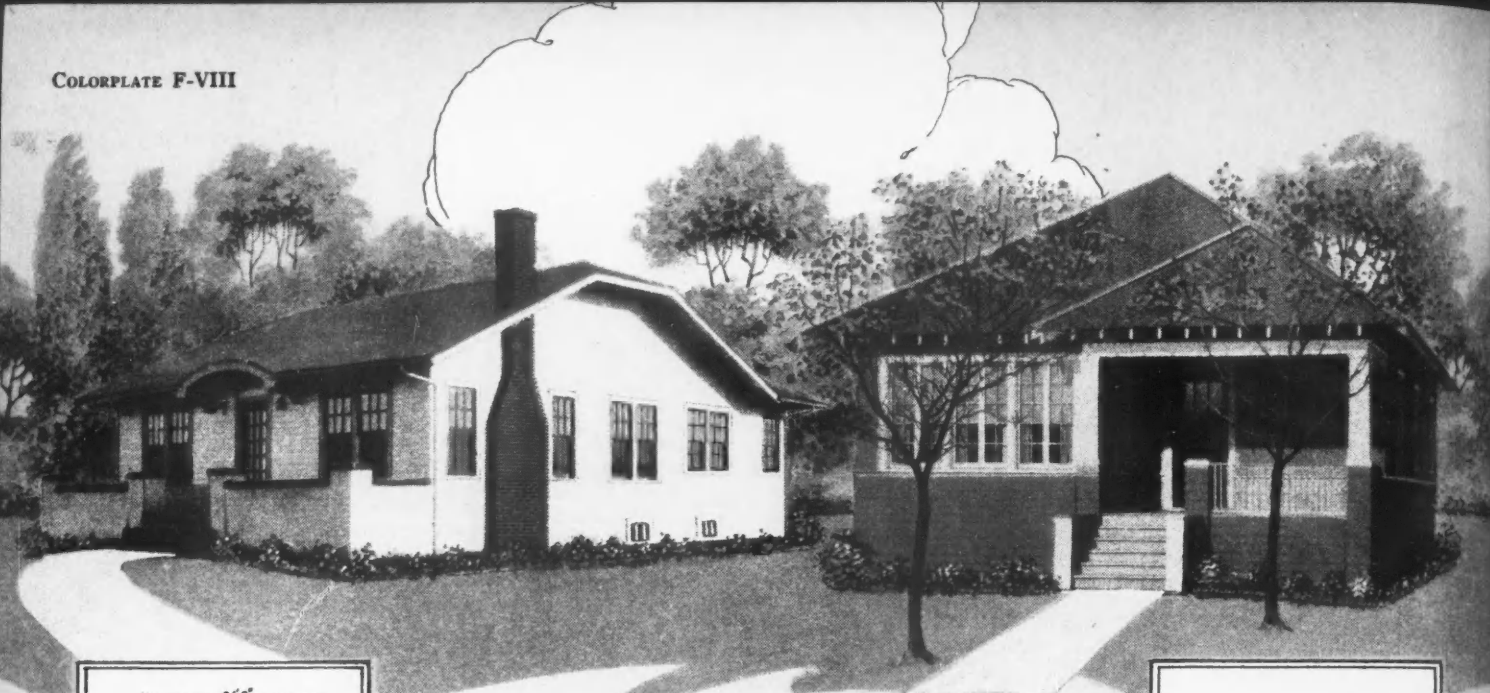

**The Fairfield**  
 Five rooms and an open terrace front porch. Size of house 24 by 48 feet.

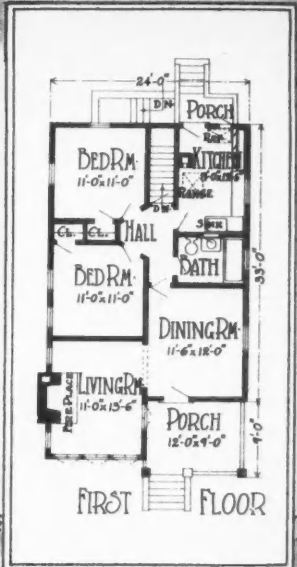

**The Falcon**  
 Five room home. Size 24 by 40 feet.

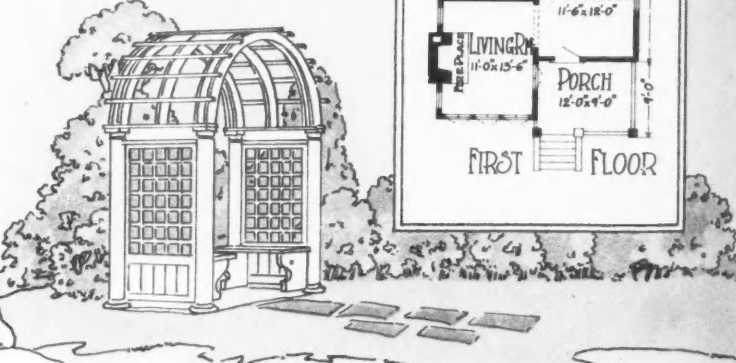

**The Fruitland**  
 Story-and-a-half bungalow of six rooms. Two-car garage designed to harmonize.

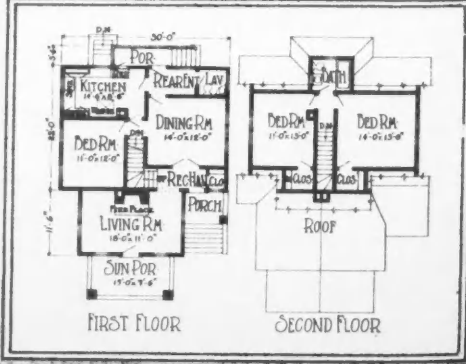

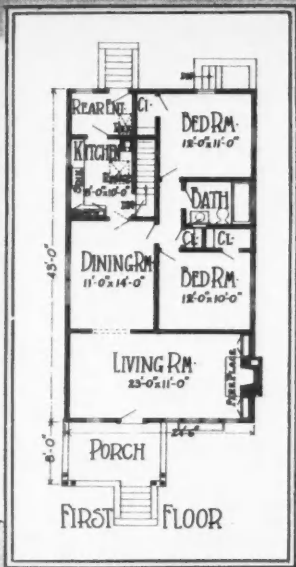

**The Fargo**  
Five rooms, but only 24 feet 6 inches wide.

**The Fillmore**  
A most attractive bungalow of five rooms. Size is 24 feet by 48 feet.

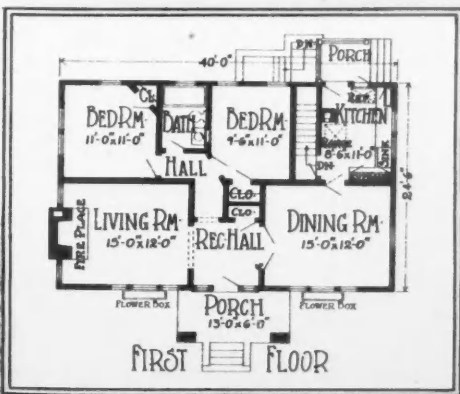
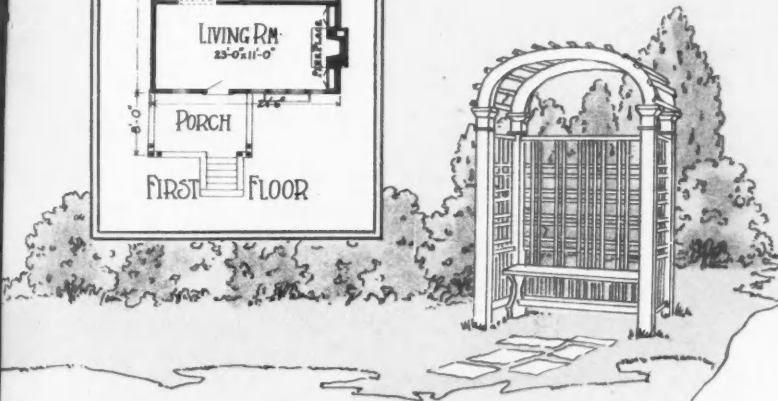
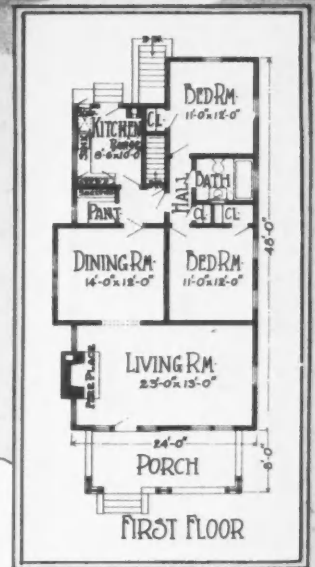

**The Fernwood**  
Five rooms and bath. Size 40 by 24 feet 6 inches.

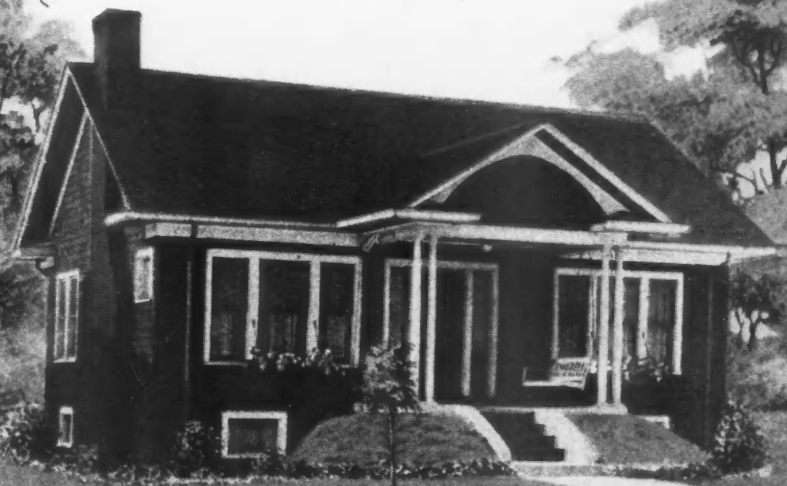







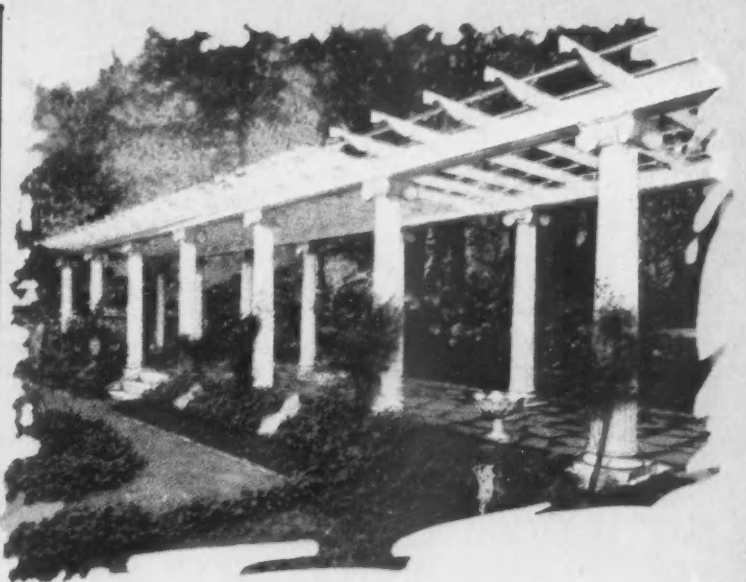
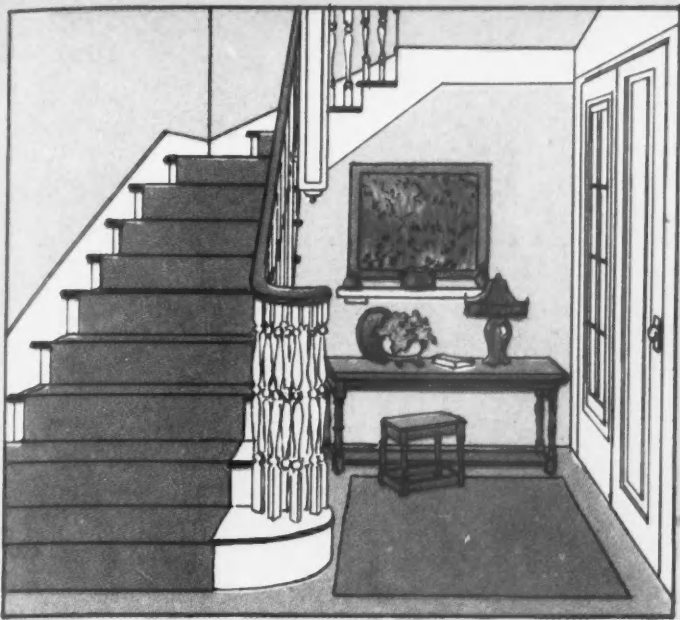

### The Fremont

A NINE-ROOM house especially planned for the narrow city lot—a brick bungalow of graceful and interesting lines. Color sketch shows attractively designed entrance stair hall. A pergola sheltered walk as illustrated to the right is a fine addition to the home grounds.

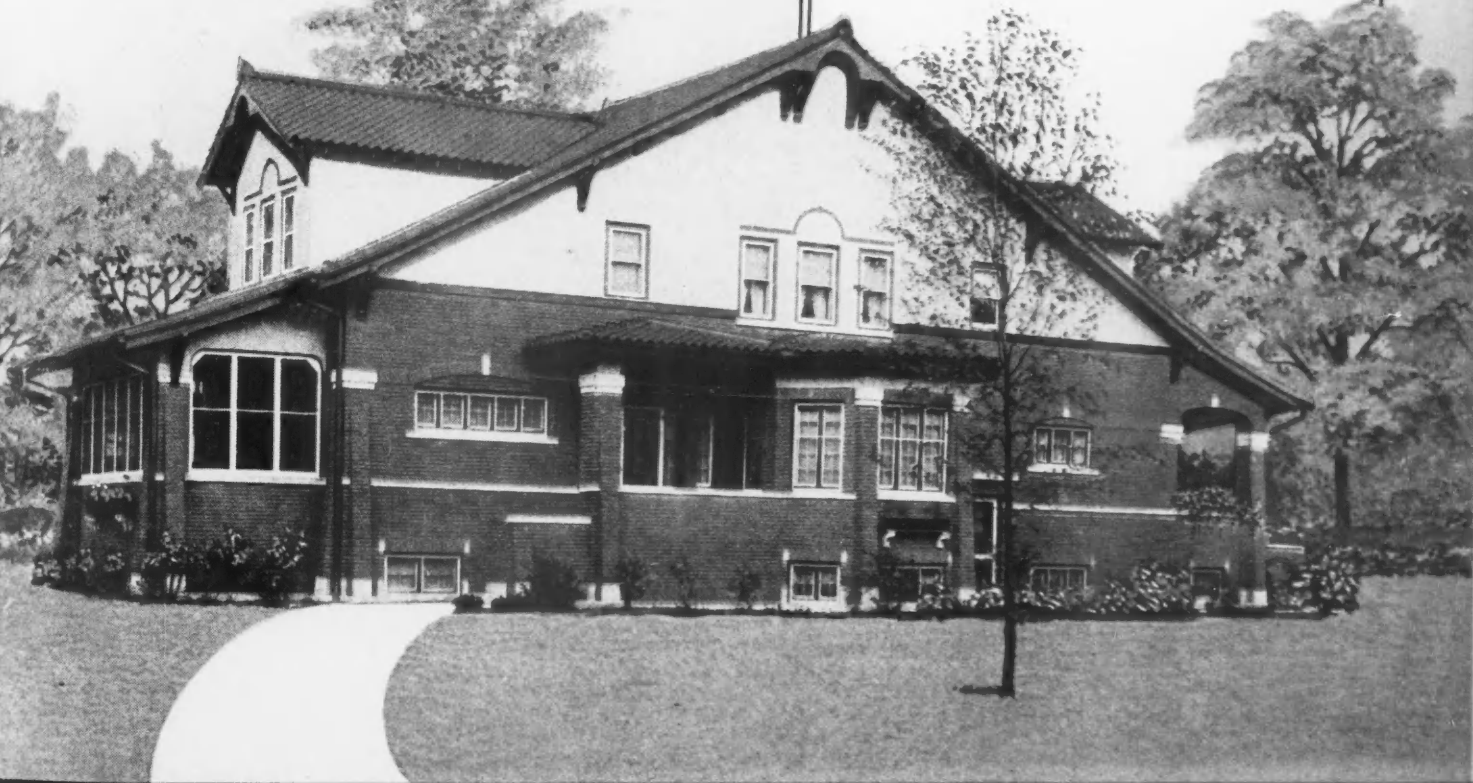
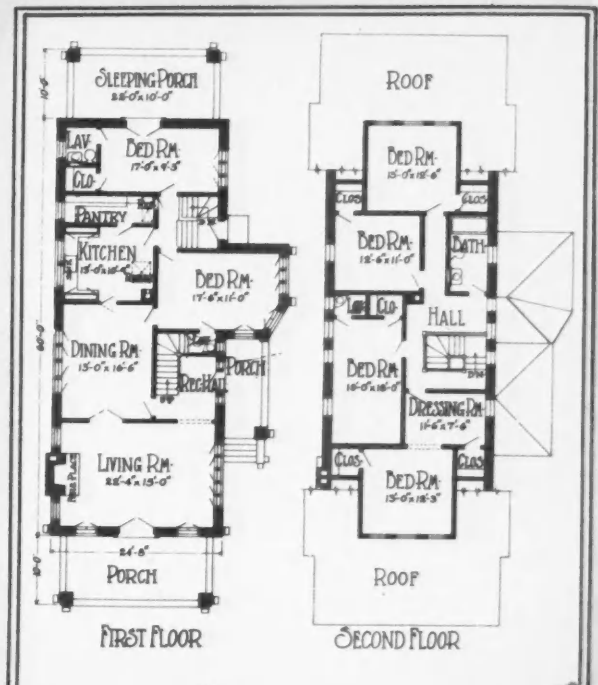

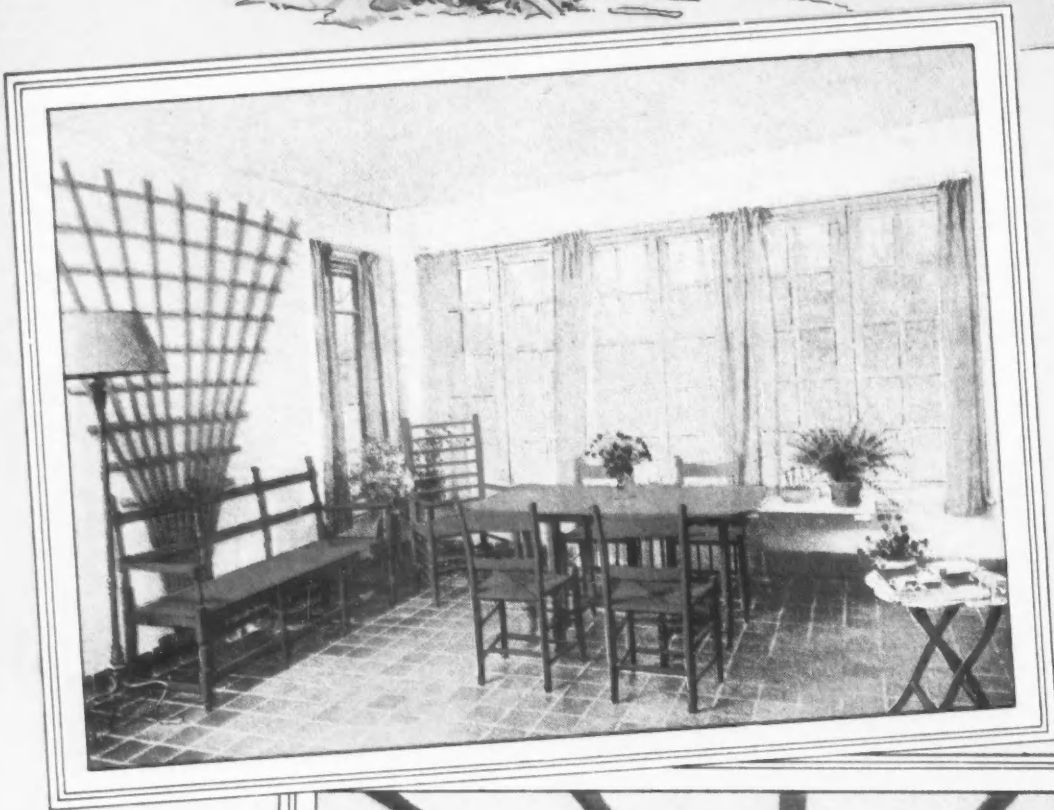

# Colonial

*A GROUP of casements (photo to left) arranged in pairs, and divided into small panes floods this breakfast room with cheerful sunshine. The jun trellis is unusual for interior decoration, but here produces a delightful outdoor effect.*

*BELOW is pictured a graceful Colonial dining room, with circle head doors balanced each side of the fireplace. Note the hand wrought door hinges.*

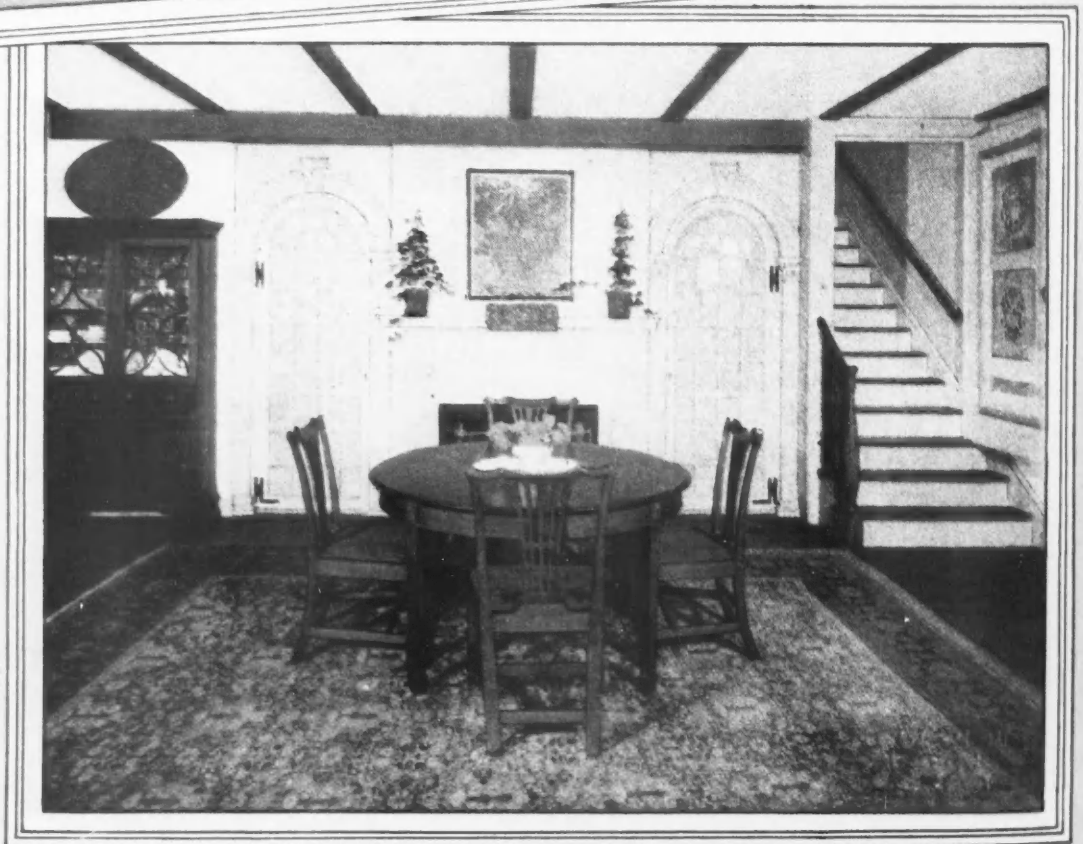

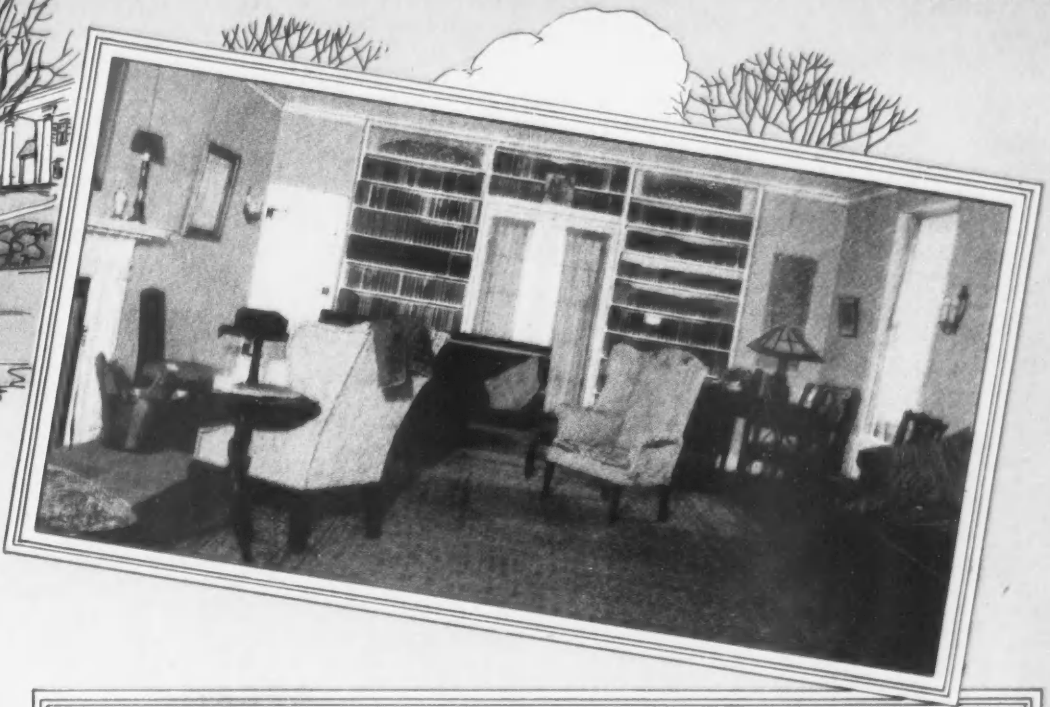

# Interiors

**OPEN** book shelves are typical of the Colonial home—and no other sort of bookcase is quite so decorative or so inviting. The library above and to right is a model.

**SPINNING** wheel, grandfather's clock, yarn measuring wheel, corner cupboard, and flower stand—all these are authentic Colonial details.

**BELOW** is shown a homelike living room furnished in the best taste to combine comfort and correct Colonial style.

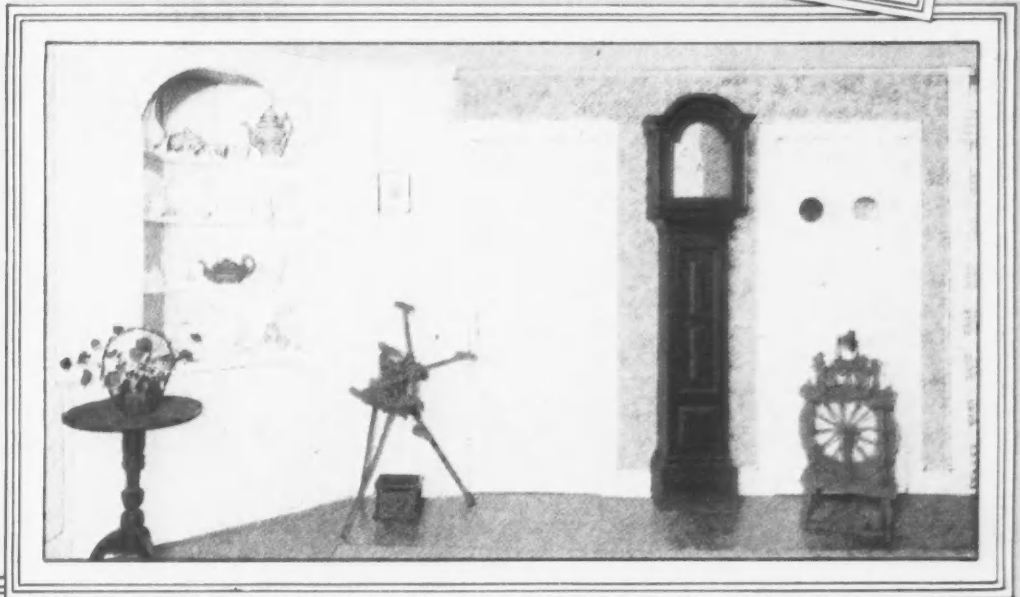



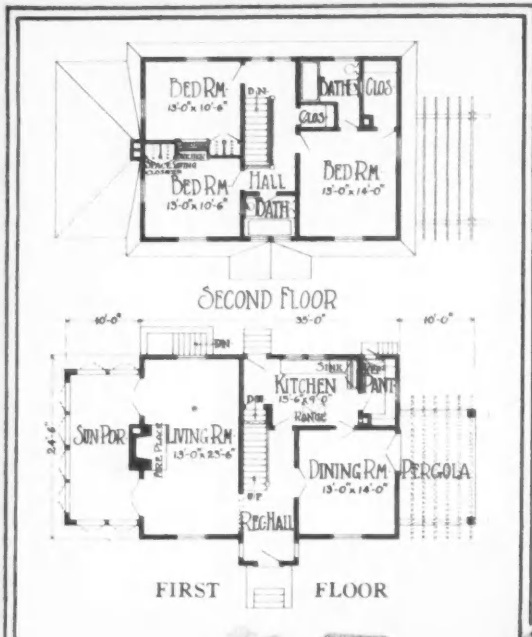

### The Franklin

HERE is a clever little Colonial, small in cost but big in convenience and comfort. The main body of the house is 24 feet, 6 inches, by 35 feet, but the width across the front is greatly increased without much additional expense by the private porch and the pergola. The color sketch suggests proper decoration and furnishing for one of the bedrooms.



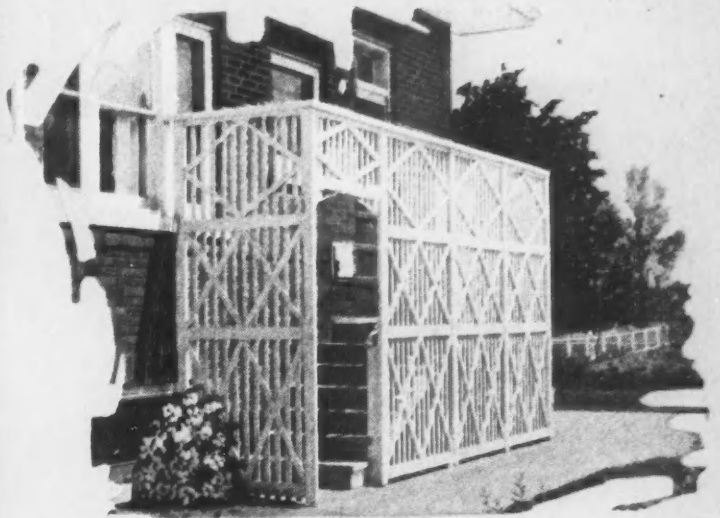
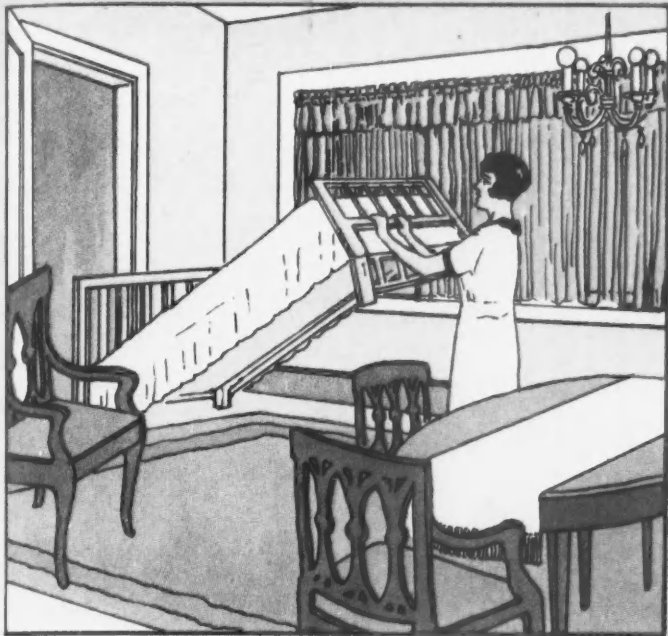

### The Flossmore

**A** COMFORTABLE brick bungalow of five rooms with attached garage to go nicely on a fifty-foot lot. Extra efficiency is given this house by the space-saving fold-away bed in the dining room with its large and conveniently placed bed-closet-dressing room. The operation of a bed of this type is illustrated in the color sketch above. An attractive lattice work screen for a kitchen entrance is shown to the right.

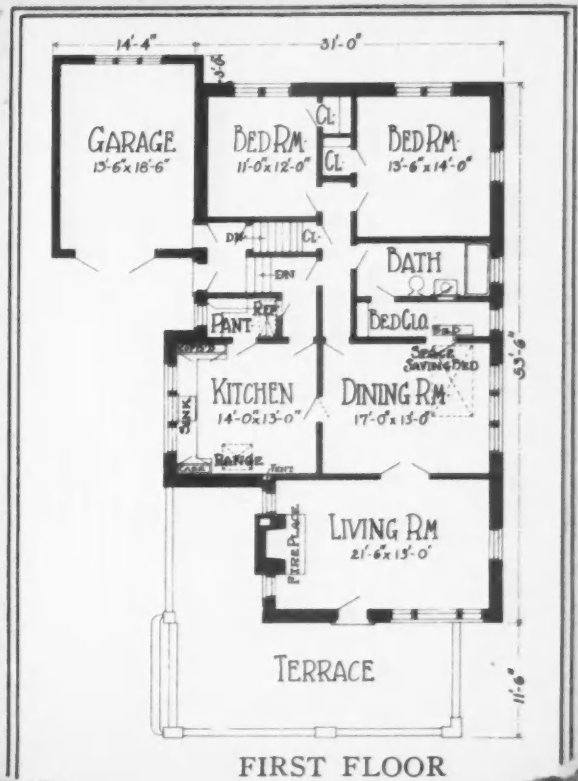



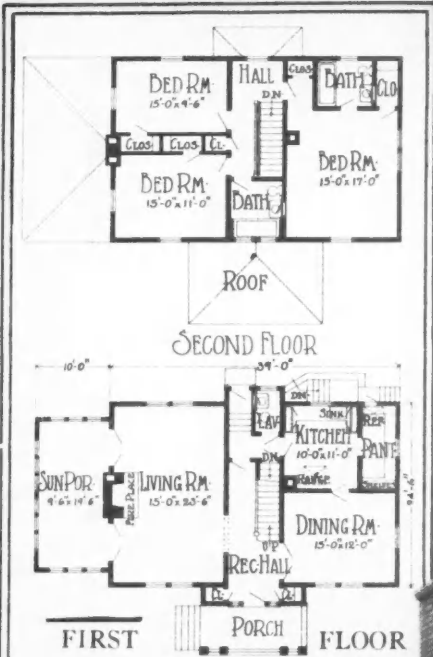
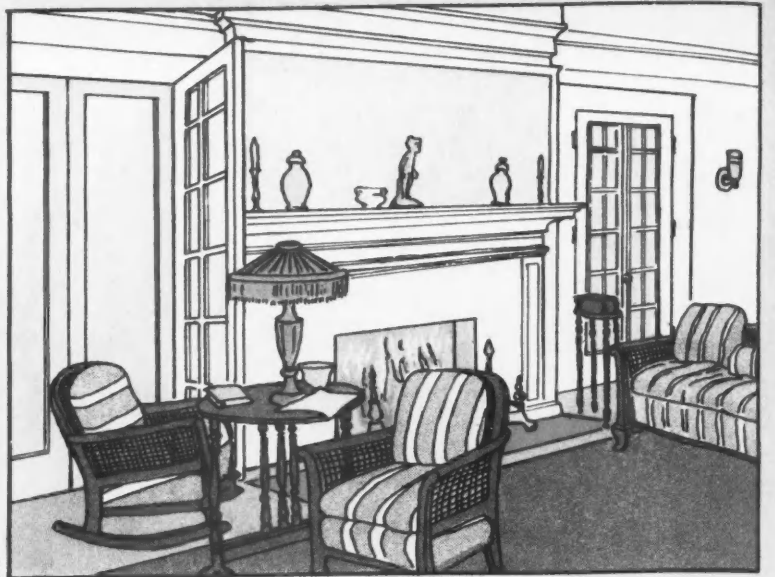
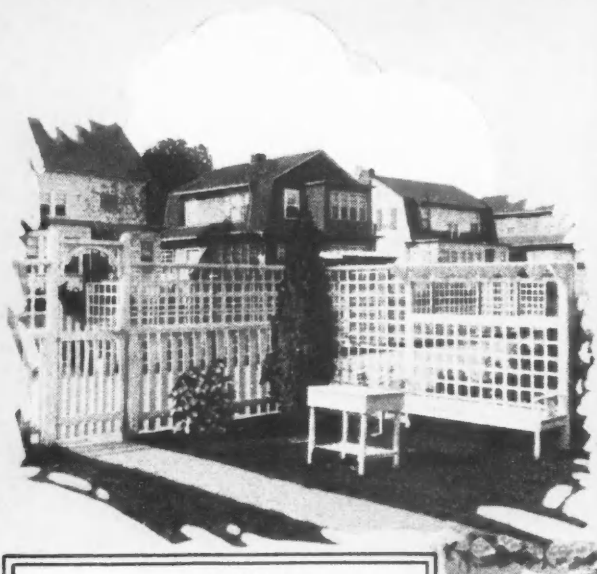

### The Frankfort

**A**N efficient, square, hip-roofed design of six fine rooms besides the big sun porch. Two bathrooms are provided on the second floor and a lavatory downstairs. There is solid comfort and great convenience in this fine home. The color sketch above suggests furnishings for the living room and to the left is an attractive lattice fence with ornamental gate-way and bench for lawn or garden.





# OUR FRONT COVER HOME

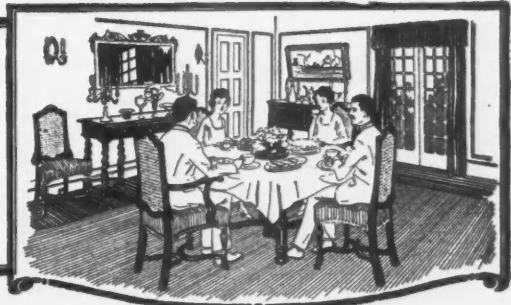

## *Straight Gable Colonial Design is Liked by Everyone and Delivers Most House for the Money Invested*

**O**UR Front Cover Home for March is a delightful Colonial—white with green shades and an open entrance approached by brick steps and wrought iron hand rails in the approved Colonial manner.

This house measures 25 feet by 36 feet 6 inches; 9-foot ceilings for the first floor, 8-foot 6-inch ceilings for the second floor. So this is not a large house and should not be expensive to build. At the same time, a surprising amount of good, livable space is provided, as a study of the floor plans will show.

This design follows the approved arrangement, with central reception and stair hall, the space to the left being given over to the large living room, 14 by 25 feet, and the space to the right being shared between the dining room and the kitchen. Directly back of the reception hall is the service entrance and the stairs to the basement. On the second floor the stairs come right to give a central hall which really takes up little space and yet carries an impression of size and dignity. To the left of the hall is a large

bedroom with private bath, and a large well-lighted clothes closet or dressing room. To the right of the hall are two smaller bedrooms, each with clothes closet. Two closets also open off the hall and the general bathroom is at the rear. The basement nicely provides for the laundry with set tubs and electric outlet for washing machine and electric irons. The heating plant is at the other end of the basement near the fuel room, which is provided under the side porch. This would be convenient either for storage of coal or for oil tanks and pumping equipment if fuel oil is to be used.

The four pages of working drawings which follow are very practical, in that they are presented here to an exact scale as marked and are complete enough so that this beautiful Front Cover Home could be actually built from these plans if desired. The construction details on sheet 3 give story heights, slope of roof and all necessary information concerning the construction of this home.



In Colonial Style, White with Green Shutters, Brick Steps and Wrought Iron Hand Rails to the Entrance, the Front Cover Home Is Roomy but Inexpensive. Working plans for this house are shown on the next four pages.

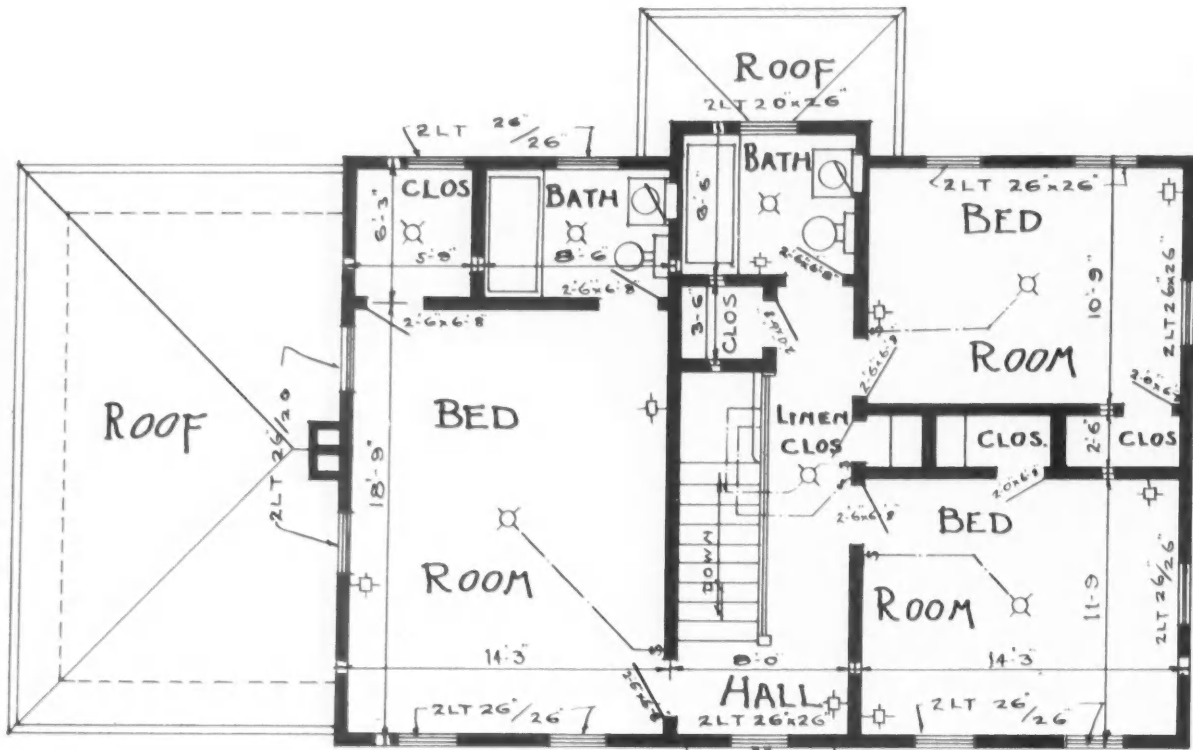

SECOND FLOOR PLAN

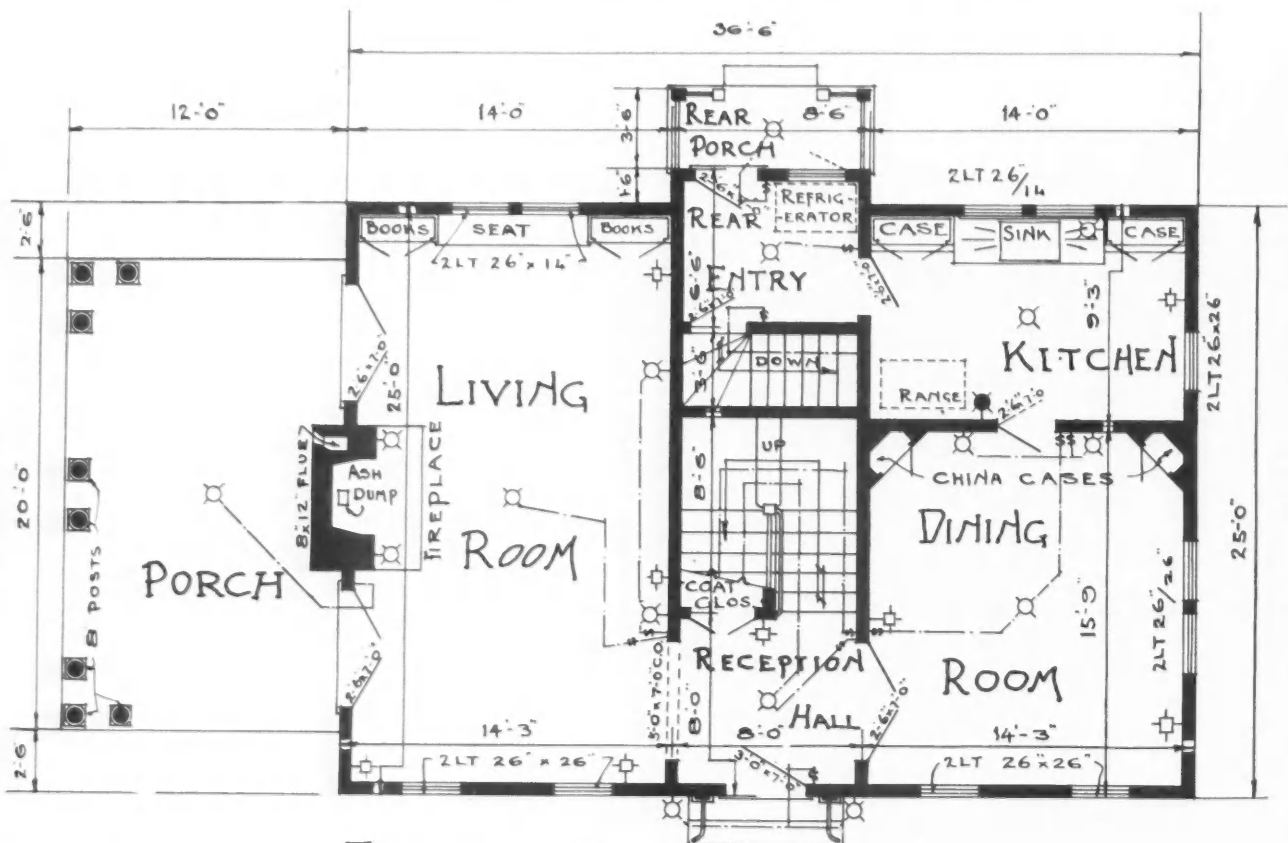

SHEET No 1 \* FIRST FLOOR PLAN \* SCALE 1/8" = 1'-0"

A Large Living Room with Fireplace, Window Seat and Built-In Book Cases Is the Most Striking Feature of the Well Arranged First Floor of Our Front Cover Home, While a Large Bedroom with an Extra Bath Is the Feature of the Second Floor. On the opposite page will be found the basement plan and front elevation.

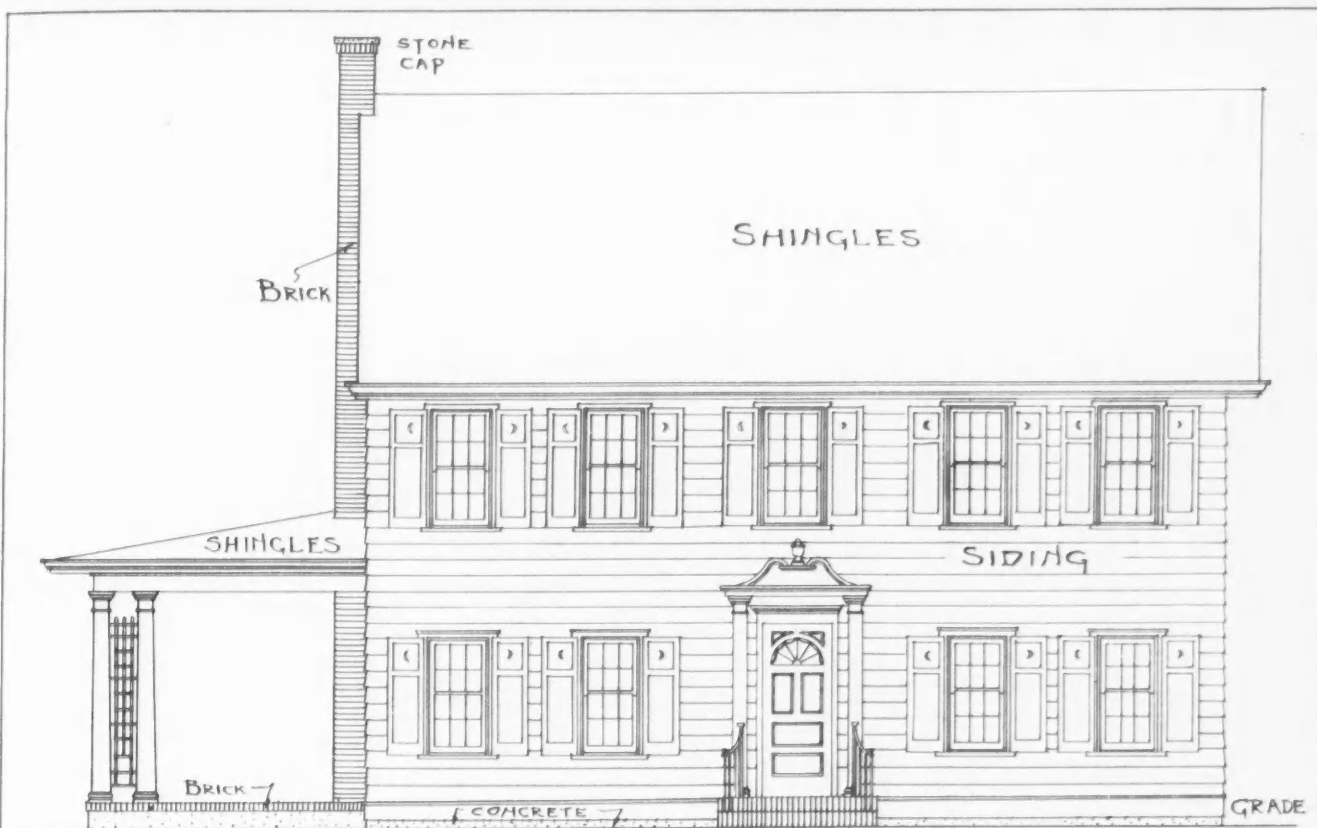

\* FRONT \* ELEVATION \*  
36'-6"

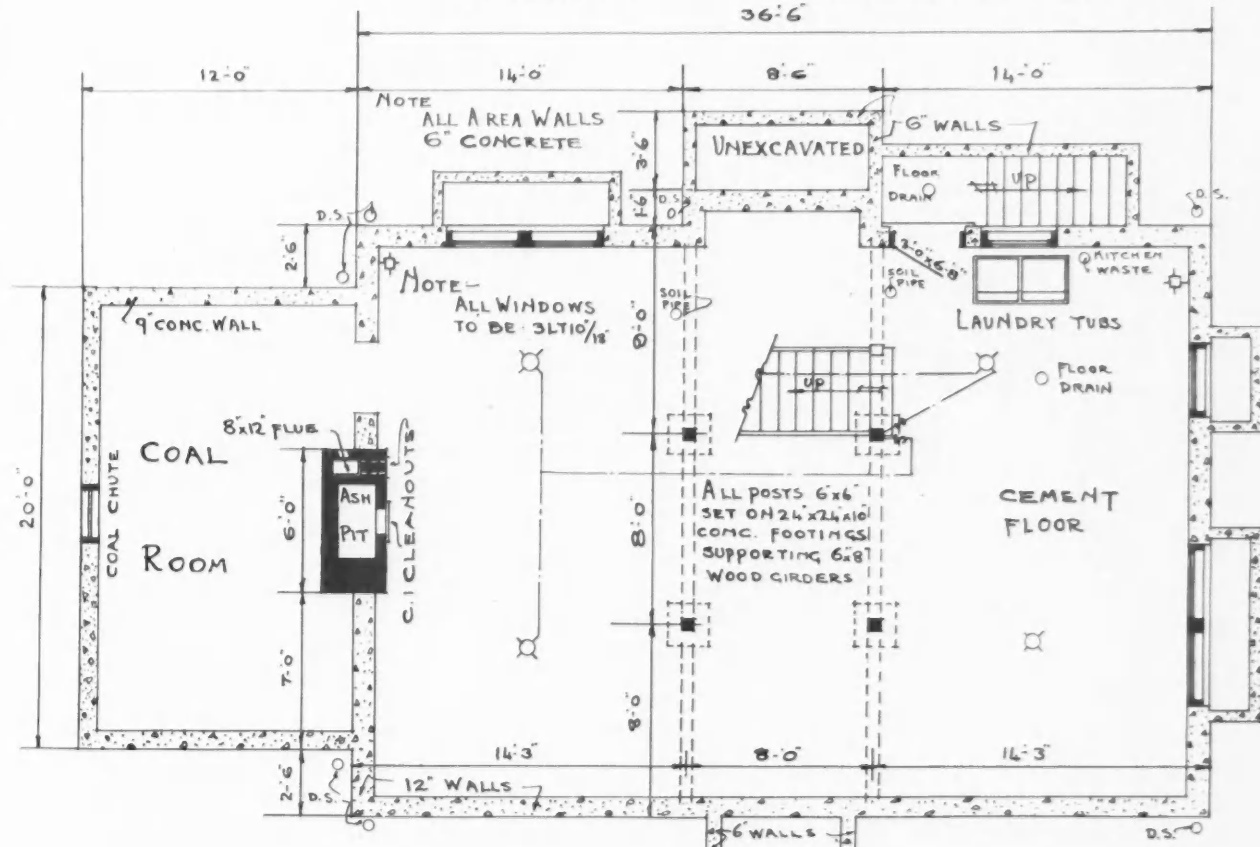

SHEET No 2

\* BASEMENT \* PLAN \*

SCALE 1/8" = 1'-0"

The Basement Plan of Our Front Cover Home Shows the Division of This Space with the Laundry Well Separated from Furnace and Coal Room. The front elevation, above, gives the placement of windows and design of the front entrance. On the next page are the left side elevation and detailed sections of construction.



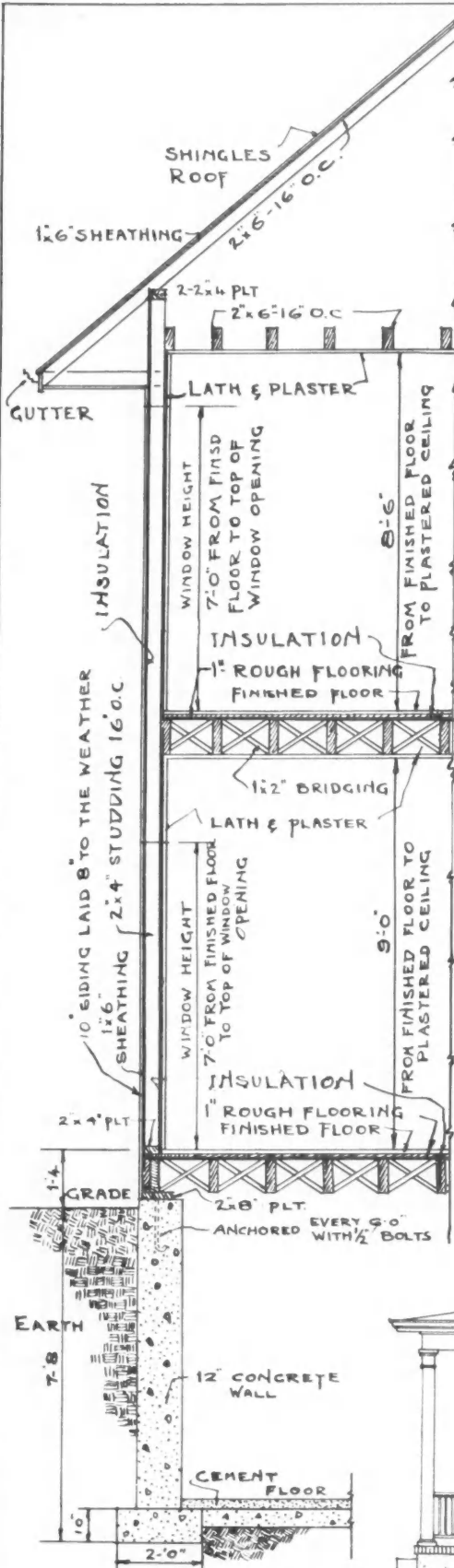

CROSS SECTION  
SCALE 1/4" = 1'-0"

SHEET No 3

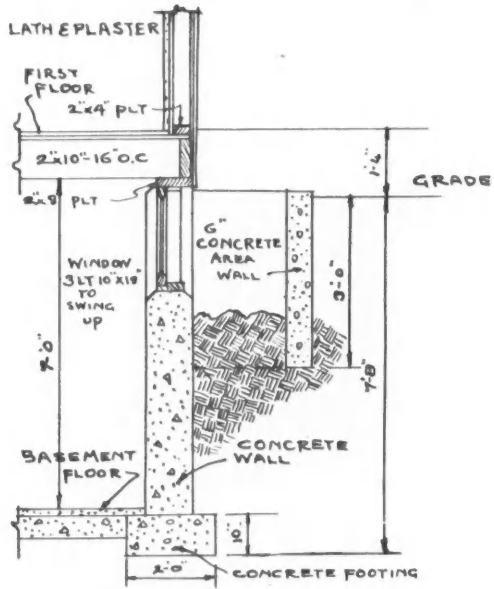

DETAILED SECTIONS  
OF  
BUILDING CONSTRUCTION  
SCALE 1/4" = 1'-0"

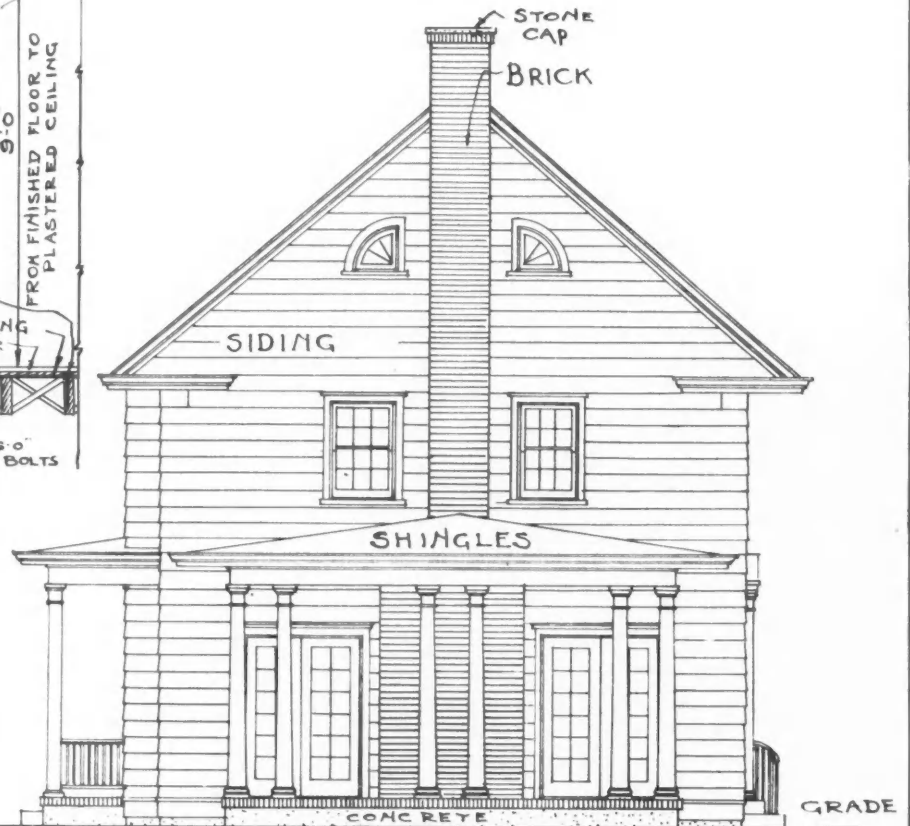

LEFT SIDE ELEVATION SCALE 1/8" = 1'-0"

The Left Side Elevation Shows the Relation of Porch, Chimney and French Doors in Our Front Cover Home. The sectional views furnish construction details of the walls, floors and foundations. For the right side elevation and construction details of porch roof and cornice see the next page.

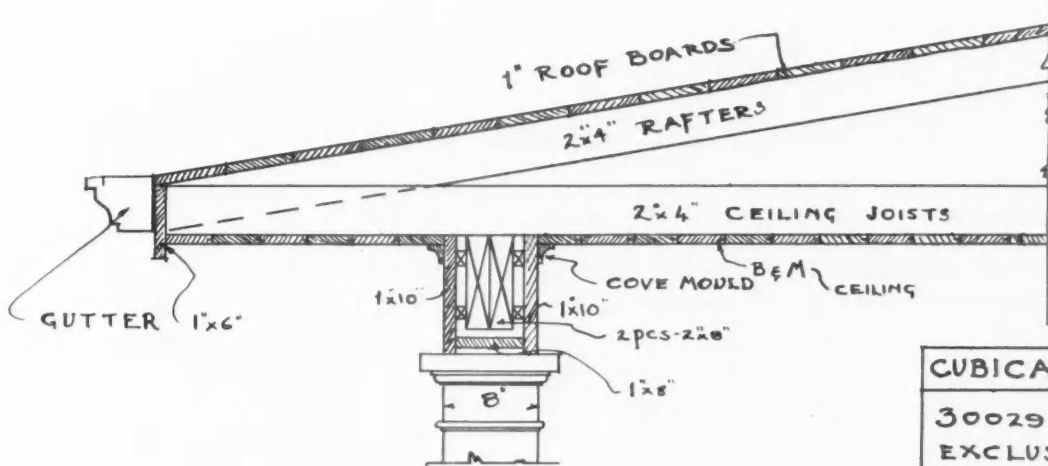

**CUBICAL CONTENTS**  
 30029 CUBIC FEET  
 EXCLUSIVE OF  
 PORCH AND  
 BASEMENT AREA  
 WALLS AND STEPS

DETAIL  
 OF  
 PORCH BOX AND CORNICE  
 SCALE  $\frac{3}{4} = 1'-0''$

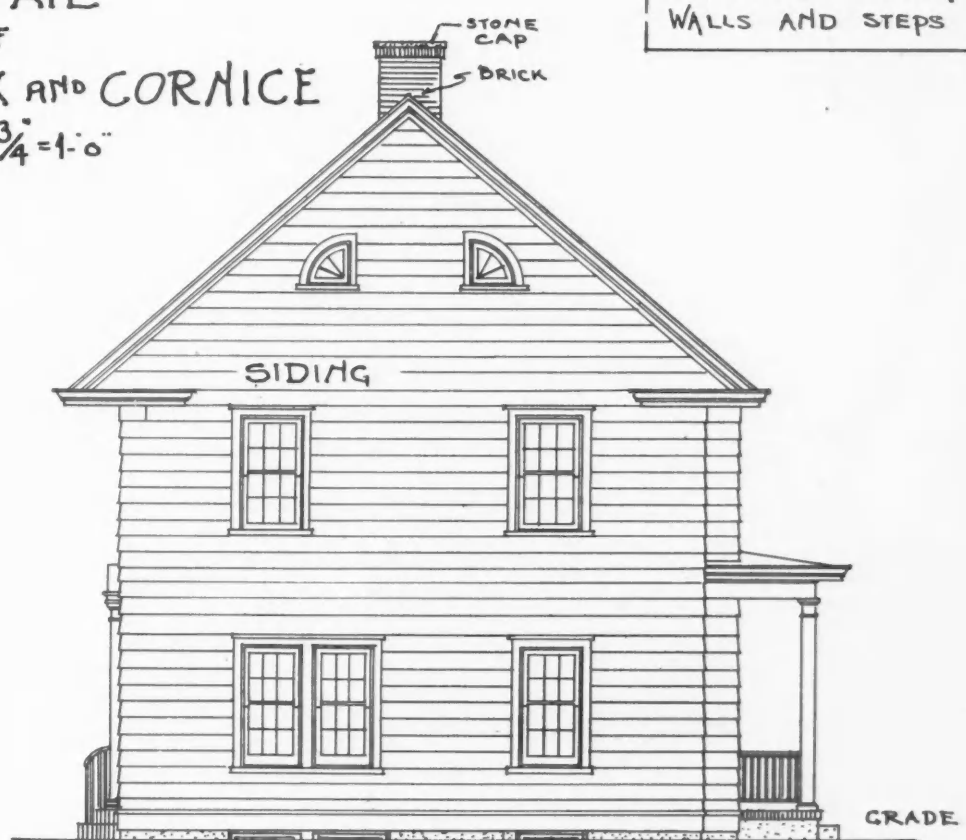

RIGHT SIDE ELEVATION SCALE  $\frac{1}{8} = 1'-0''$

SHEET No 4

In the Right Side Elevation of Our Front Cover Home the Wall is More Simple. The basement windows are placed below grade in concreted area ways. Above are the construction details of the porch roof and cornice.

# SAVE THE SURFACE DEPARTMENT

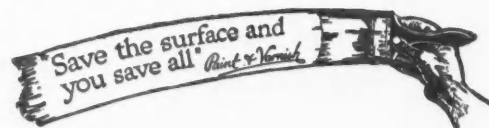

Written, Illustrated and Edited by the Headquarters  
Staff, SAVE THE SURFACE CAMPAIGN

THERE is tangible evidence of "Saving the Surface" in your hands this very minute. The cover of this magazine, according to the editorial in the January issue, has been varnished for greater service. The Editor states that it is varnished to preserve it against fading and soil, and to enhance the beauty of its coloring. In that short sentence we have the two major reasons for all painting or varnishing

jobs, great or small—preservation and beautification. A magazine such as the AMERICAN BUILDER passes from hand to hand among many people—home builders, architects, dealers, realtors, contractors and builders. The varnished cover keeps it fresh and clean long after the ordinary publication would have become a useless handful of tatters.

—SAVE THE SURFACE EDITOR.

## Less Labor in Housework

Property Improvements Which Reduce the Labor and Cost of Housework  
Have a Definite Selling Value

A WOMAN'S preference concerning details of interior finish are generally the deciding factors in the buying of a house. Modern women, through countless magazine and newspaper articles and advertisements, have been sold on labor saving devices and finishes. They are, of course, often influenced by a well planned decorative effect for living room, dining room or some other part of the house, but with nine-tenths of the women of today the absorbing question is, "Is it easy to clean?"

Fraudulent construction is a thing of the past. With most modern builders, good materials and carefully handled construction are a matter of honor, but when it comes to selling, they find that it is the clever little accessories and appointments, which are both artistic and labor saving, that appeal to feminine hearts and complete the sale.

There are four or five points around a house which a woman looks to carefully in connection with cleanliness.

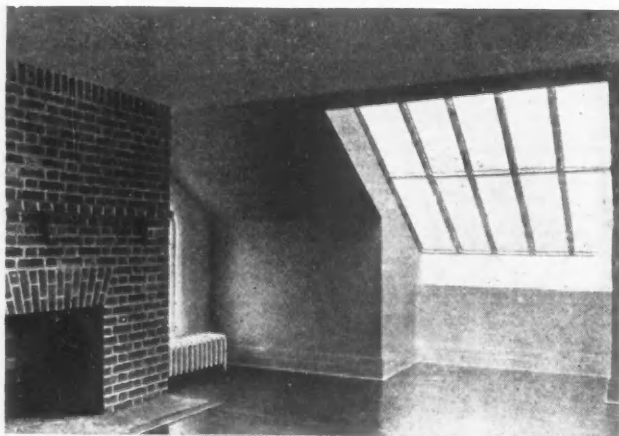

An Attic Converted Into a Studio or Playroom with Wallboard and Paint Is a Fuel-Saving Insulation. Painting the radiator to match the walls improves its appearance and increases radiation.

These are all places which she knows it will be desirable to keep in a sanitary condition; at the same time she wants to keep them so without wasted effort, without spending hours scrubbing rough, badly finished surfaces which in the end will not be clean enough to satisfy her.

The builder or the man who has real estate for sale who studies these features of a house, and after finishing them in the most approved modern fashion, stresses their desirability with a prospective buyer, will have accomplished nine-tenths of his object, a satisfactory sale.

To begin at the bottom of a house and work upwards, the up-to-date woman, who has been educated in the doctrine of "an ounce of prevention," looks to the sanitary condition and finish of the cellar, the kitchen, the walls and floors throughout the house, including the bathroom.

The cellar, the "beginning of the house," is very often not given the attention it deserves. Every cellar can and should be made watertight; health demands this. There is little doubt that damp, dirty cellars are responsible for much illness. One model twentieth century cellar has the steps painted battleship gray. A narrow white band is painted on the treads and risers where they abut against the stone cellar wall. Another white line has been carried the full width of the stairs where each tread and riser meet. These lines make each corner and angle white. The advantage of this from a sanitary standpoint, is that no dirt can lurk unseen on the step. After the stairs have been swept or scrubbed it is very evident that they are clean, and there is always satisfaction in being able to see the fruits of labor.

Still another white line, painted on the surface of the treads, at the ends farthest from the wall, adds to the appearance and furnishes a guide line in a dim light.

If the cement floor and stone walls are painted, moisture will not so readily seep through, a great deal of dust will be eliminated and cleaning will be made much easier and more thorough.

Wallboard fitted against the beams of the ceiling and painted in a light color will make the cellar more attractive and



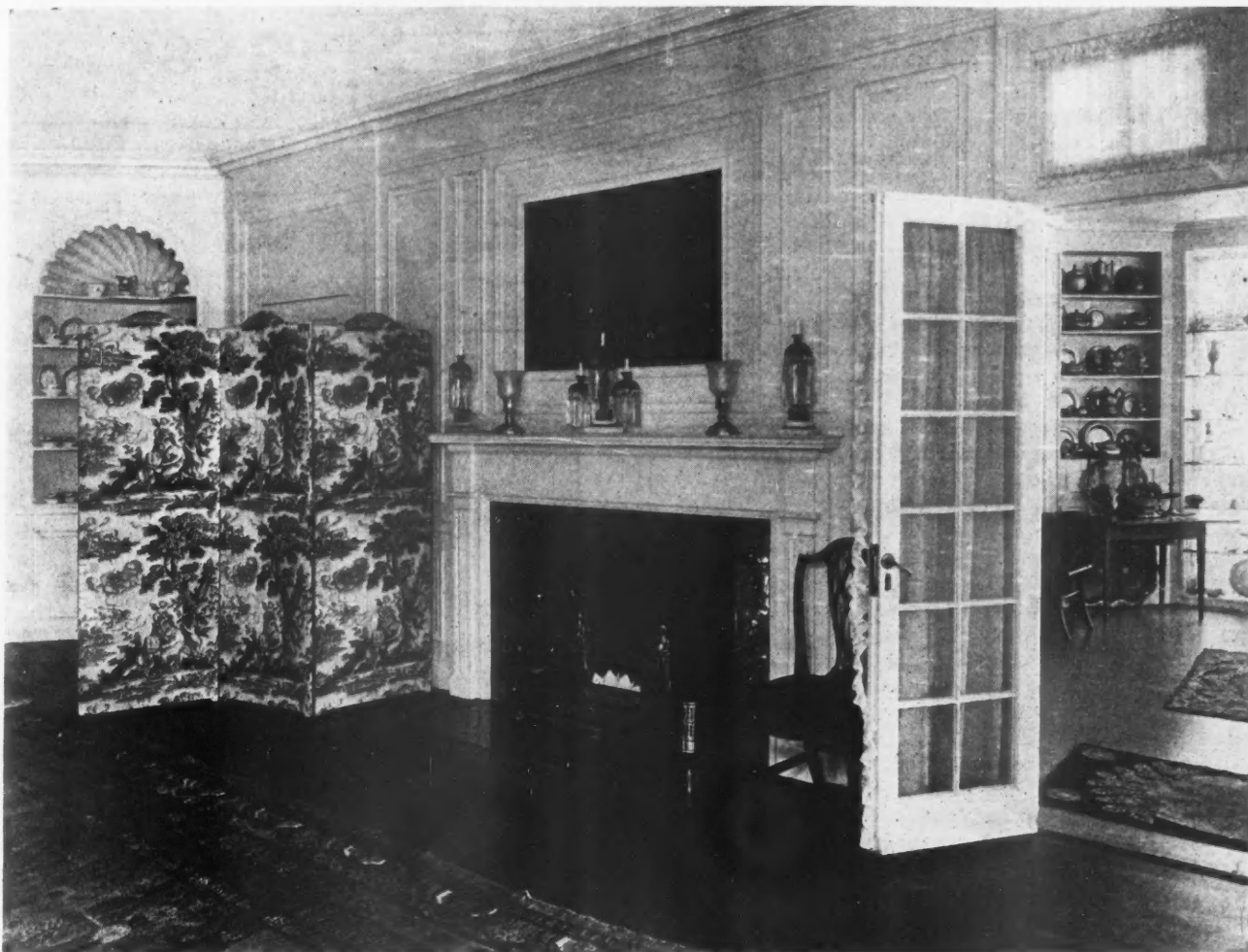

The Attractiveness of This Interior Is Not Its Only Recommendation. Painted walls and varnished floors are sanitary and easy to keep clean. They reduce the cost and labor of housekeeping.

prevent dust from sifting through to the rooms above. Drafts will be stopped, heat conserved and light reflection increased, to say nothing of the cleaning labor saved. Even without the use of wallboard, painting the flooring and beams which form the cellar ceiling will do much to secure these desirable ends.

Nowhere should sanitation be practiced more rigidly than in the kitchen where the home-maker prepares the food, thereby making herself largely responsible for the health and happiness of the family. The realization of this is the reason why the efficient housekeeper insists on painted surfaces, both plaster and wood, in her kitchen. She likes the assurance that soap and water will remove the dust and dirt where germs find their breeding places.

Tile floors are, of course, the sanitary floors, but they are cold and tiring. Besides, they take away the "homey" atmosphere and give the kitchen an institutional look. A good method to follow is to have the floor painted or varnished, making sure that all the cracks between the boards and around the subbase are well filled with crack filler after the first coat of paint is applied. A floor finished in this way will not need to be scrubbed, wiping it with a damp cloth will leave it absolutely clean.

The problem of kitchen improvement continues to be an absorbing theme with all home builders. Women want their kitchens to be practical and at the same time artistic.

One way of accomplishing this is by the use of color. The all-white kitchen has been experimented with and proved to be "too much of a good thing." It not only fails to give that much-to-be-desired clean look (unless, indeed, a woman spends nine-tenths of her working hours wiping its surfaces)

but it is hard on the eyes and nerves and not so cheering as a colorful room.

Since moisture from condensed steam and vapors from cooking discolor the walls and ceiling, no modern housekeepers want anything but painted walls in the kitchen, but many of them make the mistake thinking that walls to be washable must be white. As a matter of fact, walls tinted the desired color will "stand up" better under the application of soap and water than the pure white will. Walls painted with a flat washable finish, or with "mill-white" in pale green, dull blue, or warm yellow, combined with ivory enameled woodwork and "built-ins" will be a "flying start" towards making the kitchen durable, sanitary and attractive. Whatever the color scheme chosen, the ceiling should be painted ivory or cream. Such a kitchen will almost sell a house on its merits.

The beauty of the popular painted wall techniques is enough in itself to make them desirable, but when their washability and durability is brought to attention the majority of people are completely sold on them.

A mop slides quickly and easily over floors which are painted or stained and varnished. Floors finished in this way may be washed with cold water at regular intervals without impairing their lustre.

Painted or enameled walls in the bathroom are a good substitute for tiles. If the lower walls are tiled, the upper portion and the ceiling should be painted.

Paint, varnish and enamel are among man's worthiest labor saving inventions, though they are not always thought of as such. Try these selling points on a prospective home-builder or purchaser, and watch the result.

# Painting with Air Sprays

**W**OULD you believe that one man could paint a certain area in an hour and fifty-one minutes, while it took another sixteen hours? Would it startle you to hear that a man could paint the side of a freight car in five minutes? You ask how it is possible to accomplish these feats, and the answer is, by means of a mechanical painting machine, a device that represents the most important development ever made in the rapid application of paint.

The principle of atomization or spraying, has been known for many years and has been applied in various ways. One of the most interesting examples is that of spraying molten metals and producing a metallic coating. With a thin liquid the problem was comparatively easy, but with a viscous material like varnish, or one containing solid particles like paint, there arose difficulties. The painting machine, after much experimenting, has been brought through successive stages from a crude, imperfect tool to a simple, highly effective device, and is now cheap enough to be within the reach of any wide-awake painter.

Painting by the mechanical method can be done in a fraction of the time required for hand brushing, the paint is spread more uniformly, the coating is heavier and the work highly durable, provided properly chosen paints are used and surfaces suitably prepared. The industries have adopted mechanical painting to a very great extent, gas engines, motorcycles, tractors, automobiles, passenger coaches, locomotives, wicker furniture, metal office equipment, radiators and pianos being a few of the things finished in this way.

With this array of varied articles coated with the painting machine, how simple a matter it appears to paint a

barn or roof. Complete equipment is now available mounted on a motor truck so it is necessary only to drive up to the building, start the gas engine which operates the compressor and do the job. The cost for such work is far less than where hand work is done. In some localities, progressive painters operating these portable outfits have developed a profitable business, going from place to place painting



**By the Mechanical Method, It Is a Matter of Minutes to Paint the Side of a House and There Is a Big Saving in Cost.**



**Large Roof Areas Can Be Quickly, Economically and Thoroughly Painted with Mechanical Equipment and Their Life Is Greatly Increased by Paint.**

dwellings, barns and other buildings.

It is seldom that shingle roofs are painted because of the expense, but it is a serious matter to neglect them. Twenty years is about the life of the average shingle roof, yet this can be prolonged indefinitely by regular painting. Paint will greatly lower the fire hazard and reduce the insurance rate on shingle roofs, besides rendering protection against weather. The spray gun is well adapted to roof work because there is a wide expanse of surface, no sharp lines to be cut and the paint that should be used is thin in consistency, all combining to make an ideal spraying condition. Many attractive color combinations can be worked out between the roof and the body and trim colors of a residence, in place of the dark, weather-beaten, warped shingles so often seen.

A painter who has used the spray gun does not care to go back to the brush. It is unnecessary to bend over and fill his brush with paint from a pot. If he made this movement but once a minute, it would amount to five hundred times a day, and the resulting fatigue can easily be imagined. Again, there is no wrist movement back and forth. Every amateur painter can testify to the effort this involves. Think of what it means to be doing it day in and day out. Those who have painted ceilings know how exhausting is such labor. In contrast with this, we simply point the spray gun and pull the trigger. No wonder the spray painter has become an enthusiast.

It is not generally known that there is a very serious shortage

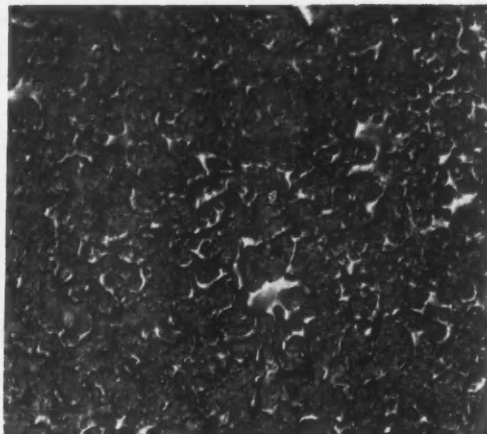
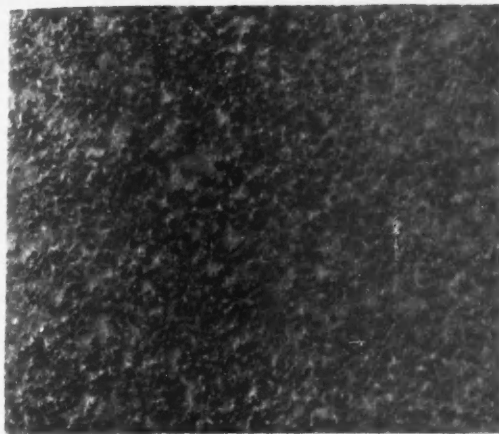

Interesting Wall Finishes Produced with a Spray Gun and Plastic Paint. A wide range of textures from a light sandpaper finish to a heavy stucco effect can be secured by this method.

of painters. One of the best posted men in the craft, a large employer, says there is work today for three times as many painters as are available, and that many painting jobs are turned down because there are no men to do them. It takes time to develop a good brush painter and so we cannot look for any immediate improvement in this situation. A natural consequence of this shortage of skilled workmen is that wages are high. The panacea for the condition is a greater use of the spray gun. With increased output per man, painting costs would be considerably lower, and countless surfaces would be saved which are now neglected.

### Color Misting

Out of the utilitarian has come the beautiful—a really new idea in wall decoration. A new technique for producing strikingly beautiful wall effects was far from the minds of the inventors as they perfected paint spray machines. Yet we have found, in these novel and interesting machines, not only great economies in time and labor saving, but also a vista of unique and handsome interiors, the possibilities of which are bounded only by the limits of imagination.

Distinctive decorative treatments for the walls of homes, also hotels and office buildings, are easily obtained with the small interior decorating spray-painting outfit. No great amount of time, labor or material, and no great expenditure for equipment or for having work done is required. The labor of decorating is lessened by more than half by the use of the up-to-date equipment, which brings stippled effects, blends and spatter work within the reach of all.

The "baby" mechanical painting outfit includes an air-compressing unit and a spray-painting unit. The former includes an air compressor, a motor to drive it and an air tank with accessories; all mounted on a portable, rubber-tired frame. The size of the motor permits ordinary lamp socket connections. The spray-painting unit is made up of a paint container of sufficient size for ground-coat work, a smaller one for spray-spatter colors, a spray gun and the necessary hose.

This decorative work is accomplished by coating the surface to be decorated with the desired ground color. The consistency of the paint is such as to produce a good hiding coat. After application, this coat is allowed to dry. Then the harmonizing spatter colors are applied in the order desired. These may be put on one after another, as it is not necessary to allow drying time between color applications. By varying the consistency of these colored paints, from pasty to liquid form, a fine or a coarse spatter effect is made possible.

Since one does not have to wait until the first spatter coat dries before applying the next, there is opportunity to obtain different effects by using flat, semi-gloss, and gloss paints. By the use of gloss paints a blending effect is possible, while in the use of flat paints, the individual colors take on a decided

spatter work." This work is a combination of two, three or more colors misted or spattered on a solid background. These treatments, like the others, are attained by the use of an exceedingly low air pressure. Spray spatter combinations are limited only by the knowledge of color harmony, the decorative sense and the number of walls to be finished.

The small paint consumption, the speed with which decoration is applied, the wide number of colors that may be used and the fact that full advantage may be taken of gloss, semi-gloss and full finish paints in producing a delicacy of finish, together with the coarseness or fineness with which the misting can be done, are points that specially recommend this treatment to both owners and decorators. A sprayed finish appropriate for any room can be selected and all such finishes possess the sanitary and washable characteristics common to painted walls and so important in the home.



### Stucco Mixed with Magnesium Chloride —Not Calcium Chloride

ON page 121 of the January issue, in the description of the home of Mr. Grinnell F. Oliver, Wheaton, Ill., an erroneous statement appeared in regard to the manner in which the stucco was mixed. This stucco was mixed verterly stated. The AMERICAN BUILDER hopes that none of its readers will be misled by the former statement which was discovered too late for correction in the January issue.



### Forestry Films Released

TWO motion picture films have recently been completed and added to the list of films which can be obtained from the U. S. Department of Agriculture for educational purposes. Both of these films deal with the problem of timber supply.

"Pine—From Seed to Sawmill" tells of the service which the southern pine has rendered since the resources of the Lake states became depleted and sounds the warning of the rapid depletion of the southern pine area. This film is two reels in length.

"Pine for Profit" pictures the depletion of the forests of the South from the settlement of Jamestown in 1607 to the present day and the practicability and methods of reforestation. It also contains a warning against fire, the greatest menace to reforestation.

Both of these films were prepared by the Forest Service in co-operation with Georgia Forestry Association, the Florida Forestry Association, and the State Forestry Commission of Alabama.



# Sheet Metal Details

## Sheet 5—Methods of Flashing Around Roof Openings

EDITOR'S NOTE—This is the fifth of a series of articles, presenting authentic details for flashing and metal work problems in building. The drawings, presented on the opposite page, were prepared by the Copper and Brass Research Association, and may be applied in the use of all roofing metals.

The first of this series was published in the November issue

of the AMERICAN BUILDER. Readers will remember that the drawings are intended to show the details of construction for every trade involved and are suitable for use by the drafting room in designing details. The distortion of the drawings will be apparent at a glance, but this purposely has been done that the methods may be made more clear.

### NOTES FOR DRAWINGS ON OPPOSITE PAGE

**FIG. 25.** The method of flashing a sheet metal ventilator set on a sloping shingle roof is shown in Fig. 25. The ventilator is fastened to the flashing by a soldered lap seam. This may be done either before or after the ventilator is set in place. The flashing when placed on the roof should lap the shingles on the sides and bottom from 6 to 8 inches and be formed over them. At the top of the flashing the shingles lap over the metal which should be carried up on the roof far enough so that the upper part of the sheet is covered by at least two thicknesses of shingles. The flashing is fastened to the roof sheathing by long brass woodscrews. Care should be taken not to split the shingles. The holes for these screws should be drilled, not punched, and the screws set through slotted brass washers. Only four screws are shown in the illustration, but if the ventilator is a large one more will be required. They should be spaced not over 12 inches apart. When completed the screw heads and washers should be well covered with solder. The lower edge of the flashing should be turned back on itself  $\frac{1}{2}$  inch for stiffness. Attention is called to the matter of "guying" as described in Fig. 26.

**Fig. 26.** If the ventilator is placed on the ridge of the roof instead of the slope the detail shown in Fig. 26 is used. The method is similar to that described in Fig. 25 except that the flashing is entirely outside the shingles. In both cases Figs. 25 and 26 it is necessary, if the ventilator be a tall one, in order to avoid strain on the flashing connections, to steady the ventilator by rods or wires secured to the roof. These rods or wires are fastened to the ventilator as near the top as possible by brass collar and fastened to the roof by brass screw-eyes or a similar device. The flashing consists of a piece of sheet metal extending out on the roof about 8 inches on each side of the fastenings, and long enough to extend from the butts of the shingles next below up and under the shingles above as far as possible. The sheet is soldered to the shank of the fastening, or a thimble is fitted around the shank, soldered to the sheet, and filled with waterproofing compound. These screw-eyes can also be waterproofed as described in Fig. 28.

**Fig. 27.** When vent or other pipes come through a roof a detail as shown in Fig. 27 is used. The lower edge of the flashing should lap over the shingles not less than 4 inches, but the sides and top are placed under the shingles with a lap of about 6 inches over the copper. If the flashing is over 12 inches wide the lower edge should be turned back and under on itself  $\frac{1}{2}$  inch. This stiffens the metal and prevents lifting by the wind. This flashing should be carried up to the top of the pipe and secured either by an iron cap screwed in place as shown in Fig. 29 or by a copper cap as shown in Fig. 30. (See description of these figures.) The flashing should be carried up above the top of the shingle course on which it rests and held in place by a row of copper nails along the upper edge.

**Fig. 28.** Many instances occur where the roof is pierced by steel members such as the struts to hold a platform or some similar structure. Great care should be used at these places not only to make the point of penetration water

and damp-proof, but also to allow room for proper expansion and contraction for the steel member. For this purpose the detail shown here is recommended. The composition roof is laid in the usual manner close to the steel member and a copper collar is bent around the member conforming somewhat to the shape and extending out on the roof from 2 to 3 inches or more, if necessary. The ends of the collar are lapped and soldered and the pan is filled with pitch or other water-proofing compound. The part extending out on the roof is covered with two extra layers of fabric, the copper having been first carefully swabbed with pitch. Where a tile roof is used it is laid on top of the regular roof waterproofing. In some cases it will be found necessary to make the vertical and horizontal parts of this pan in two pieces. The joint between the two parts should be a soldered lap joint. When the penetrating member is large in proportion to the pan for holding the waterproofing compound the member, if of steel, should be heated with a torch to secure proper adhesion.

**Fig. 29.** There are two recognized methods of terminating the flashing when a vent-pipe comes through the roof. One method is shown in Fig. 29. The horizontal flashing is turned out over the roofing from 6 to 8 inches and turned up against the pipe enough to form a  $\frac{1}{2}$ -inch lap seam with the vertical collar. A sheet is placed around the pipe and soldered to the horizontal sheet. Some roofers coat the outside of the pipe with white lead or asphaltum before placing the flashing. The flashing on the roof is covered by two additional layers of roofing and the top of the flashing on the pipe is held in place by a wrought-iron cap screwed on the top of the pipe and enclosing the end of the flashing. Before placing this lap the threads should be coated with white lead.

**Fig. 30.** Where cast-iron pipe is used the flashing is shown in Fig. 30. It may also be used for wrought-iron pipe. The roof and vertical portions are constructed as described in Fig. 29, but the top of the vertical portion is held in place by a copper cap forced down over the pipe and the flashing. This cap should be 6 inches high and should project into the interior of the pipe at least 2 inches. The vertical flashing should be carried high enough so that the cap will lap at least 4 inches.

**Fig. 31.** When a flagpole extends up through the roof the flashing is shown in Fig. 31. The flashing is turned out on the roofing about 6 or 8 inches and turned up near the pole enough to allow a lap with the collar around the pole. This collar is to be lapped vertically and also over the base flashing and both laps well soldered. The collar and the flashing must be kept away from the pole to allow for its vibration. A flared collar-hood is then placed around the pole extending down so that it will lap the base flashing at least 3 inches. This hood is held by a brass band 1 inch wide set in white lead and securely bolted in place. The lower edge of this hood is turned back on itself  $\frac{1}{2}$  inch for stiffness. With very tall poles it is usual to brace them from the roof by rods secured to a collar several feet up on the pole. The method of waterproofing the rods at the roof connection is similar to that described in Figs. 26 and 28.

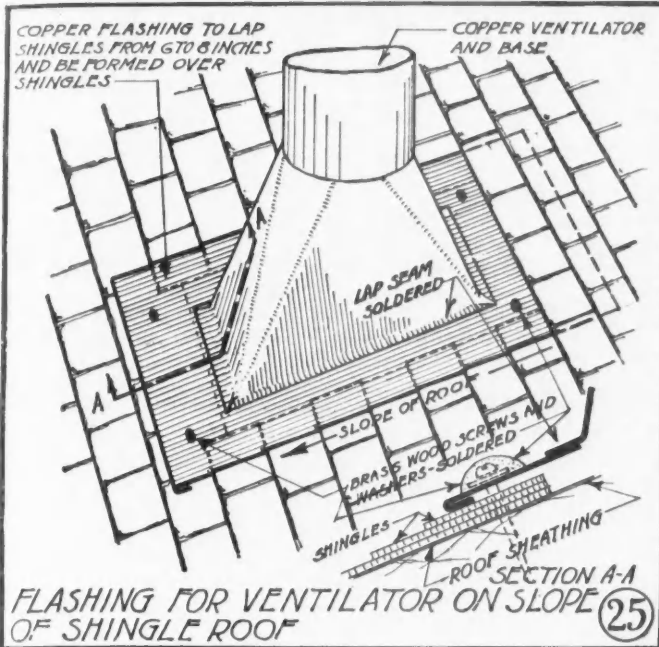

FLASHING FOR VENTILATOR ON SLOPE OF SHINGLE ROOF (25)

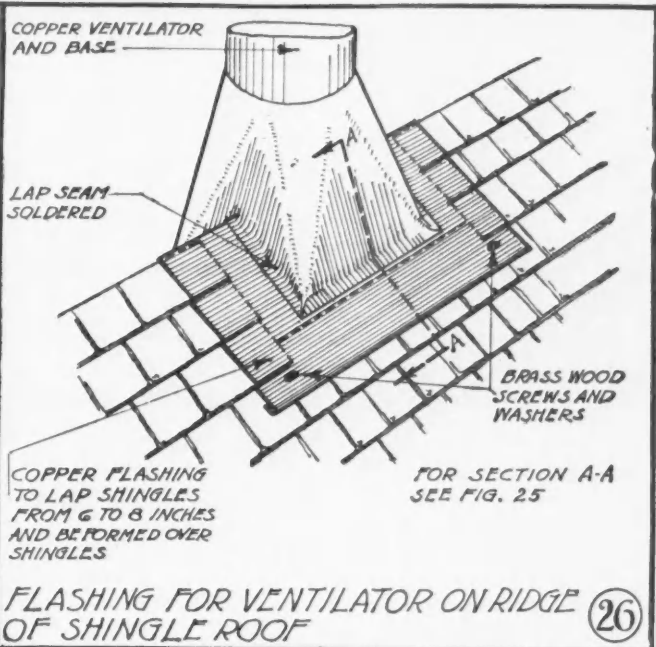

FLASHING FOR VENTILATOR ON RIDGE OF SHINGLE ROOF (26)

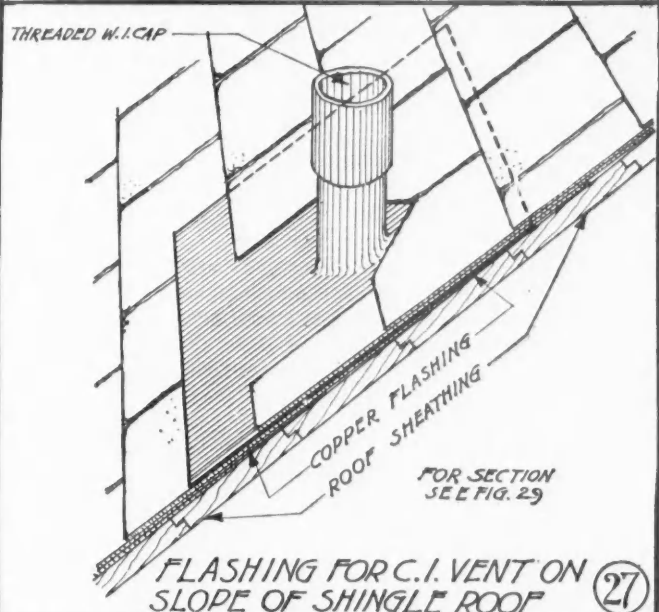

FLASHING FOR C.I. VENT ON SLOPE OF SHINGLE ROOF (27)

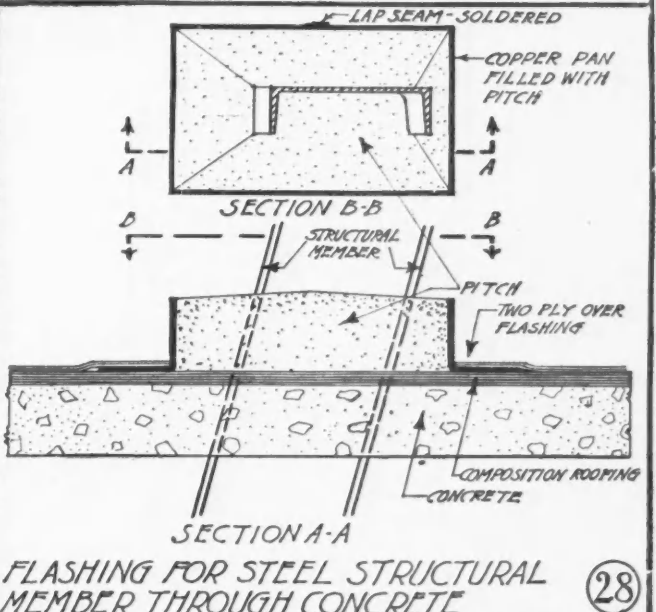

FLASHING FOR STEEL STRUCTURAL MEMBER THROUGH CONCRETE (28)

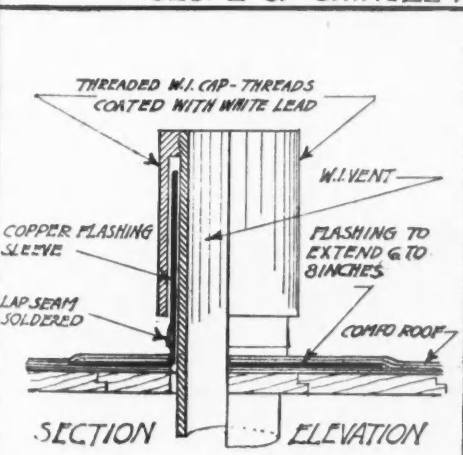

FLASHING FOR IRON VENT WITH SCREW CAP (29)

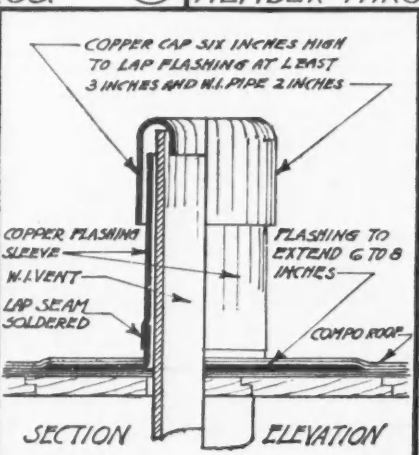

FLASHING FOR IRON VENT WITH COPPER CAP (30)

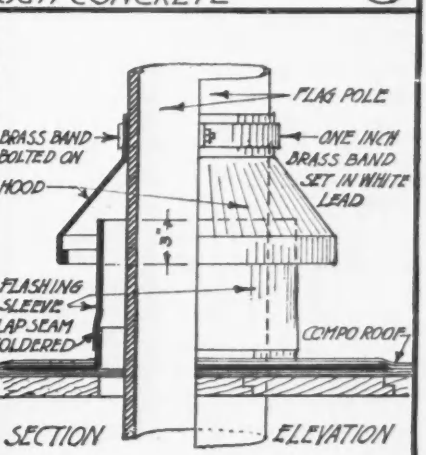

FLASHING FOR FLAG POLE (31)



# HOW DAN DOES IT.

*A Department for Passing "Life Savers" along to other Builders.*

## \$2 for an Idea

Dan is an ingenious cuss. Nothing ever stumps him. He always knows the way out when he runs into a tough problem out on the job or in the office. Dan is going to edit this Department and will pay \$2.00 each for every good idea he can use here to show and tell other builders "how to do it." Send him a rough sketch and a short description of what the tough job was and how you handled it.

Address Dan-Do-It, care of American Builder, 1827 Prairie Avenue, Chicago, Ill.

### Aid When Dressing Boards

IT was necessary for one carpenter to dress the edges of some wide but thin boards, and, as he did not have the proper clamping fixture on his work bench, he experienced considerable trouble due to the fact that his bench stop would not hold a wide board on its edge so that he could dress it with ease. It was therefore necessary for him to have one man hold the board erect and steady while another used the plane.

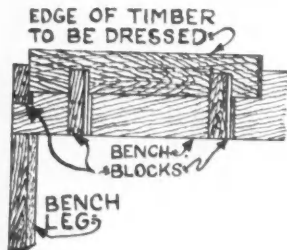

To eliminate one "hand" and to do the work correctly and with ease he nailed some blocks to the side of his work bench, as shown in the sketch herewith, and placed the boards between the blocks and the side of the bench, as illustrated. The inside blocks should be fully as thick or thicker than the boards to be dressed.—BUNYAN KENNEDY, McCool, Minn.



### Laying Off Foundations

THE old method of squaring a foundation with a chalk line and a ten-foot pole is a very slow way and sometimes an inaccurate way for several reasons. First, the wind may blow your line back and forth and give you a lot of trouble. After getting your measurements of six and eight on the line, the line will stretch and throw your measurements off and you will have to keep making measurements and shifting your line until you finally succeed.

For years I have used a big wooden square made of one by fours for squaring foundations. This big square gave satisfaction for what it was made for, but I have lately improved it and I believe that other contractors and carpenters will be glad to know how it is made.

Any carpenter can make this big square. All the material he needs is a 1 by 4 by 12 and a 1 by 4 by 16, a half of a wagon tire and a bolt half inch by 10 or 14 inches long and two bolts three-eighths by one and a half inches. These two bolts are to be used to bolt the wagon tire to one of the one by fours as shown in the illustration. The

14-inch bolt is merely an iron stake with threads run down on one end about three inches, which passes through the two one by fours where they intersect. There are two taps on the threaded end of this stake, one on top of the upper one by four and one under the bottom one by four.

This bolt serves as a hinge on which either blade of the square may be made to turn and, at the same time, when driven into the earth, holds the corner of the square in the desired position. For further information see the illustration. The half circle, as shown in the figure, may be made of a wagon tire, but care must be taken that this half circle is absolutely true. There are 180 degrees in a half circle and it makes no difference what size the circle is.

After the half circle has been made the ends are twisted and bent at right angles to the rest of the circle. Next divide the half circle in 180 equal parts. These divisions will represent degrees, and a notch should be filed into this

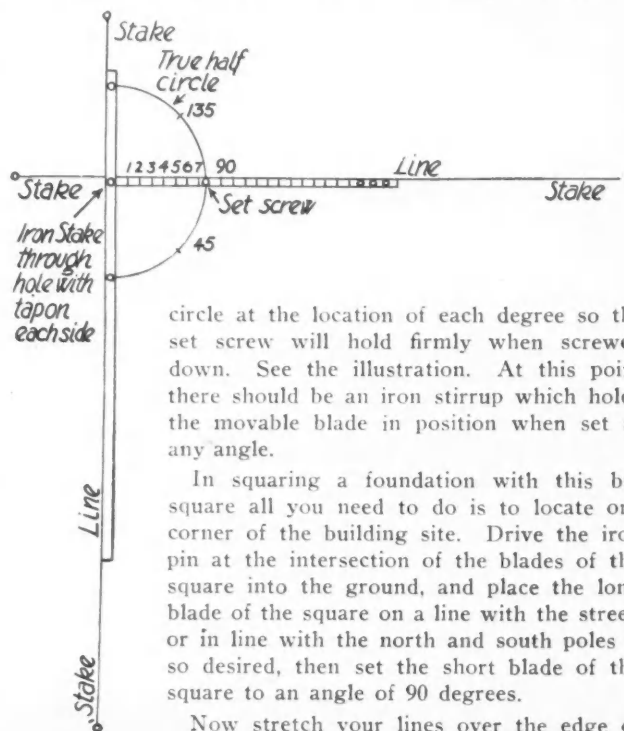

circle at the location of each degree so the set screw will hold firmly when screwed down. See the illustration. At this point there should be an iron stirrup which holds the movable blade in position when set at any angle.

In squaring a foundation with this big square all you need to do is to locate one corner of the building site. Drive the iron pin at the intersection of the blades of the square into the ground, and place the long blade of the square on a line with the street, or in line with the north and south poles if so desired, then set the short blade of the square to an angle of 90 degrees.

Now stretch your lines over the edge of



each blade of the square and tie the ends to stakes, as shown in the detail. This will square one corner of the building, and if the building is to have no wings the other three corners will naturally be square if your measurements are correct. But if the building is to have either an "L" or a "T" you may square them also by moving the square to the location, laying the long blade on a line of the main wall and driving the stake at the desired point as explained above.

A contractor often has to put up buildings with sharp corners on account of the fact that the lot on which it is located is not square. Here is where this big square will be found handy again. In such cases all you will have to do in running your lines correctly is to set the big square to the correct angle and proceed as you would on a square building.

This big square may also be used as a compass in drawing circles a foot to 24 feet in diameter, as shown in the sketch. In drawing circles on the ground for silos, cisterns or for any other purpose, drive the iron stake at the corner of the square into the earth, then if you want to draw a circle 12 feet in diameter slip an iron pin through hole in the short blade of the square six feet from the corner, take hold of the end of the long blade and turn the whole thing around, allowing the pin to make a mark on the earth.—B. F. CLARK, Albuquerque, N. M.



## Cleaning Corrugated Roofing

SOME time ago I was called upon to paint a corrugated iron roof. It had been a long time since the roof had been painted and the old paint was pretty well worn off by

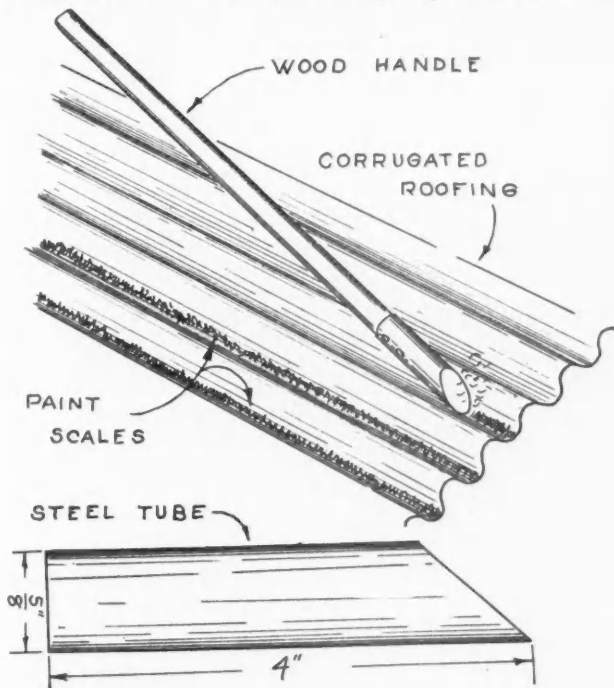

This Scraper Is a Convenient Tool When It Comes to Cleaning a Corrugated Roof for Painting. It is easily and cheaply made and fills a need for which there is no similar tool available.

the weather except in the bottom of the corrugations. Here the paint was quite thick and dried hard. It was in the form of scales which curled up at the edges. I knew that it would not do to paint over these partly loose paint scales, so I tried to sweep them off with a broom, but they stuck too tight for this.

After thinking a while I made the simple tool shown in the sketch. It consists of a short piece of steel tubing secured to the end of a long handle. This was used as a scraper and did a perfect job of removing the scales. After scraping, the roof was swept to remove the loose scales.

The handle was long enough so that I could stand erect while using the scraper.—HAROLD JACKSON, Kankakee, Ill.



## Cutting Strips of Paper

EVERY carpenter, some time in his experience, has had the job of cutting strips of paper to be put under the outside casings of window frames. There are various

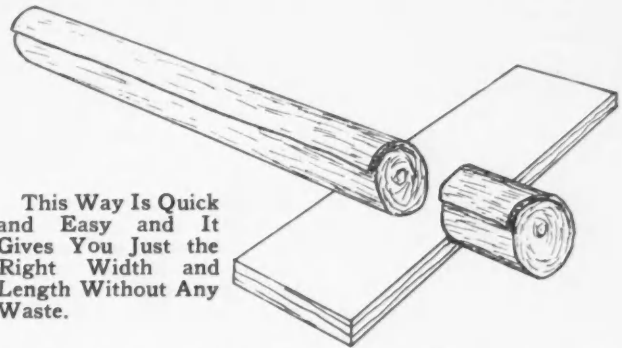

This Way Is Quick and Easy and It Gives You Just the Right Width and Length Without Any Waste.

methods in use, such as sawing and cutting with a knife. We have discovered a simple way of cutting these strips of paper that will not only save time but will make it possible to cut the exact number of strips at the right length, thus avoiding waste of material.

Assuming that we need 48 strips of paper four inches wide and five feet long, from a roll of paper 32 inches wide cut off six pieces of paper five feet long. Lay these sheets of paper on each other and roll them up into as small a roll as possible, then mark the roll into eight equal parts and with a hand axe cut the roll of paper into eight four-inch rolls.—H. H. SIEGEL, Emporia, Kan.



## Repairing Decayed Posts

A VERY simple way to repair decayed fence posts, or any other kind of posts, is shown by the sketches. Fig. 1 shows a post which is almost rotted off. Instead of taking the post out and putting in a new post (which often means the taking down and rebuilding of the fence), dig the dirt out around the post about two feet deep, and fill this space with concrete, as shown by Fig. 2. The heavy dots, connected with irregular lines on each side of the post, indicate woven wire fencing, which reinforces the concrete.

This repairing can be done while the post is still answering the purpose for which it was put into the ground. The life of the post, after it has thus been repaired, will be longer, in most instances, than the life of a new post, and the expense will be much less.—H. SIEGELE, S. Emporia, Kan.

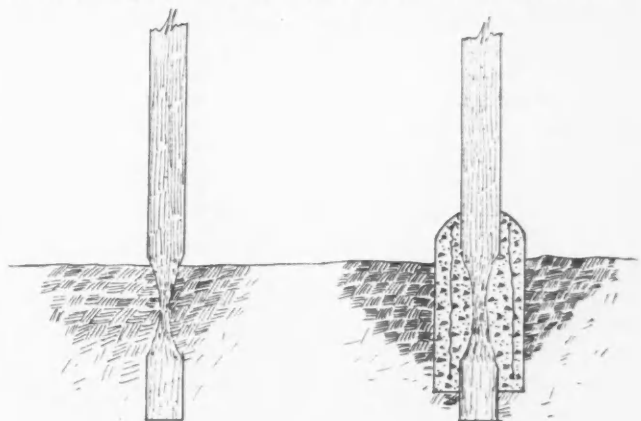

Fig. 1.

Fig. 2.

This Method of Repairing Fence Posts Not Only Saves Money and Effects a Permanent Repair, but Is One More Aid in the Very Important Matter of Conserving Our National Timber Supply by Securing the Longest Service from Wood Already in Use.



**EDITOR'S NOTE:** *The AMERICAN BUILDER does not accept payment in any form for what appears in our reading pages. In order to avoid any appearance of doing so, we omit the name of the maker or seller of any article we describe. This information is, however, kept on file and will be mailed to anyone interested; address AMERICAN BUILDER Information Exchange, 1827 Prairie Ave., Chicago.*

### Portable Electric Saw

**P**ORTABLE saws, which can be easily transported to the job and moved about to any part of building under construction, are a great convenience and money saver for the builder. The saw shown in the illustration is of this type and has ample power and capacity for the heaviest work in the ordinary run of building operations.



**For Remodeling Jobs This Saw Is Particularly Convenient as It Can Be Taken Right Into the House and Plugged Into a Light Socket.**

It is operated by power from the electric lighting circuit, it being only necessary to plug in on an ordinary light socket, and it is light enough that it can be quickly and easily moved from floor to floor as the work progresses. In this way it saves the time of workmen in climbing up and down ladders or stairs, while saving hand work in all cutting and fitting operations.



### Widest Rolling Steel Door

**T**O meet the need for an unusual width doorway, to admit cars at an angle to a building, where interior loading platforms left no room for sliding or swinging doors, the widest rolling steel door ever manufactured has recently been installed. The masonry opening is 45 feet wide and 17 feet high. The door is made of No. 16 gauge interlocking steel slats and weighs two tons.

The overhead, horizontal shaft, which measures 47 feet between supporting brackets, has a deflection of less than one inch. Enclosed in the shaft are 12 heavy helical springs which counterbalance the weight of the door. The motor bracket is a self-contained unit driving the shaft with a  $7\frac{1}{2}$  H. P. motor through a train of spur gears. Only three

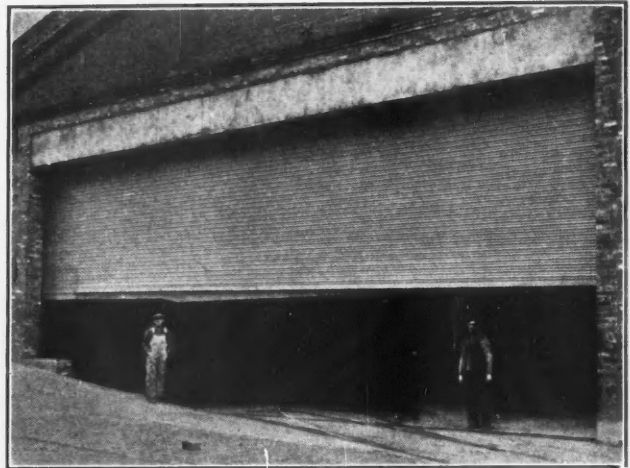

**The Widest Rolling Steel Door Ever Built Closes an Opening 45 Feet Wide and 17 Feet High and Can Be Opened or Closed in 30 Seconds.**

horsepower is actually required to raise or lower the door due to the counterbalancing springs.

Operation is controlled by a set of push buttons and the door may be stopped in any position. It is automatically

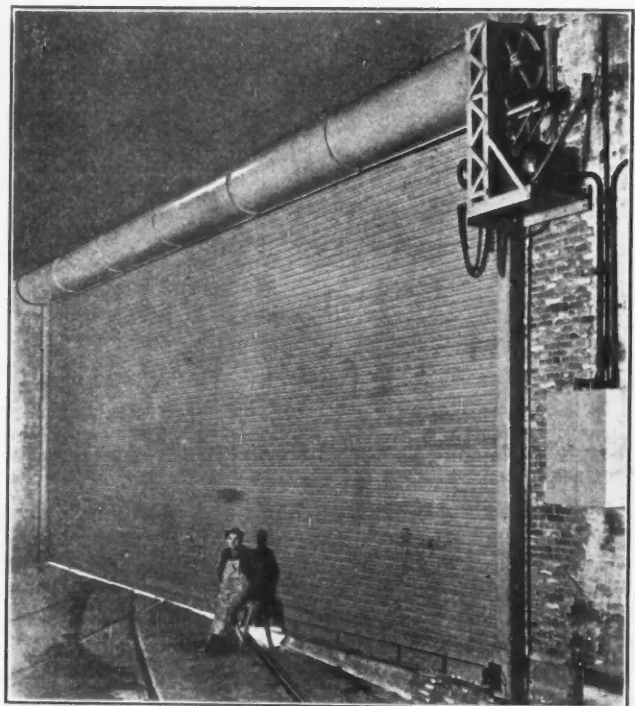

**When Opened the Door Is Completely Encased in the Housing Seen at the Top. The shaft encloses springs which counterbalance the weight of the door.**

stopped at the top and bottom by a double set of limit switches. Quick stopping is accomplished by a combination of dynamic and solenoid brakes. A sprocket and hand chain operation is available for emergencies.

The roller door coils entirely overhead, above the lintel, and is enclosed in a 26-inch semi-circular sheet steel box or hood.



### All Steel Ironing Board

**S**OMETHING new in the way of built-in home equipment is offered in the form of an all-steel ironing board which can be readily installed in any house under construction or already built. It is of a size, 14½ inches wide, to fit between standard studding without cutting. The opening is 54 inches high, 34 inches above the floor line.

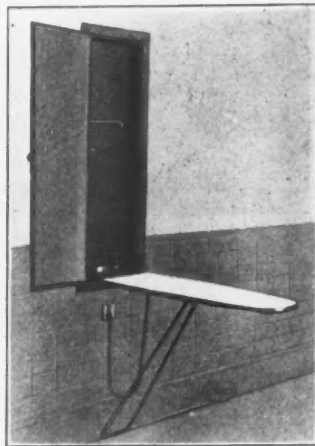

All Steel Ironing Board.

The cabinet proper is of heavy gauge sheet steel finished with a flat coat of pearl gray enamel which is an ideal ground for any standard finish. The sheets are assembled by the welding process making a rigid and substantial job. The board is stamped from 20 gauge steel and is heavily reinforced and guaranteed not to warp. The folding leg, of a special design, forms a firm brace for the board and cannot get out of order.

The cabinet contains a raised platform for the iron when not in use and also a retainer rod which swings outward to serve as a towel or handkerchief rod.



### Vertical Sliding Garage Door

**W**HEREVER garage space is limited a vertically sliding garage door will be especially appreciated. With this door the consideration of space for the door to swing outward or slide sideways is eliminated. When open it is entirely overhead in a horizontal position and out of the way with no danger of blowing shut. Even on a very narrow alley the garage may be built to the property line without making it necessary to even partially block the alley with an open door.



The Sliding Garage Door, Open and Closed.

Where space is not limited this door is a great convenience, as it is protected from weather when open, is always easily opened and gives an absolutely clear, unobstructed entrance. It is strongly built and easily installed, an average carpenter being able to do the job in about two hours' time. It is made in any desired size.

The door proper is made up of panels hinged together. A door eight feet or less high is made in four panels and the number is increased for greater heights. Rollers are attached at both ends of the panels and are held in position on steel tracks, on which the door operates overhead. The door is perfectly counterbalanced in all positions by two coil springs of uniform tension. When closed it rests flush on the floor and fits perfectly at sides, top and bottom, making it weatherproof.



### Electric Door Opener

**A**N electrically operated device is being manufactured which opens and closes heavy doors and gates, of both the sliding and swinging type, noiselessly and automatically.

This mechanism is operated by touching an electric button. It is intended for use in public garages and in banking institutions for opening and closing the gates to the safe deposit vaults and for large residences where the gates to the grounds are heavy.

The device is operated by a one-sixth horsepower motor which not only furnishes the driving force for opening the door, but also stops the door at the proper point. Therefore, it is impossible for the doors or gates to slam either in the opening or closing action.

The entire mechanism, with the exception of a small arm which fastens to a door of the sliding type, is concealed. The motor unit is concealed and protected in an easily accessible cast iron box installed just below the floor level.



This Is the Little Device Which Will Open or Close the Heaviest Door or Gate Merely by Pressing a Button.

### Metal Basement Columns

**A**LL metal columns for basement posts are being marketed in stock lengths of six, six and a half and seven feet. Special lengths are cut to order. These columns are made of four and five-inch reclaimed pipe with a cast iron steel cap and base and are thoroughly painted at the factory. They come under approved code construction in all the leading cities and are considered superior construction everywhere.

Their greatest advantages lie in the fact that they are much more quickly erected than masonry pillars and also save valuable space in the basement.



### New Idea in Mixing Boxes

**A** NEW steel mixing box, under which a fire is built to warm the mortar, is provided with a steel hod support which slides along the edge of the box wherever desired. It has also been used with a brick-walled fireplace upon which the mixing box rests like a stew pan. It is claimed that these steel mortar boxes will outlast dozens of wood boxes, at the same time giving greater utility, due to absence of knot holes, splitting and cracking.



Steel Mortar Box Has Special Advantages.

Every top edge of the steel box is reinforced with double steel flanges, affording an absolutely rigid construction all around, and also providing permanent handholds, only two men being required for easy handling. Although they are riveted throughout, there is not a rivet inside the box, and the smooth, one-piece metal bottom has no obstructions to catch cement or interfere with the mixing tools.

The boxes are made in three standard sizes. This same company also manufactures steel mortar boards under which a fire can be built for the same purpose.



### Welded Plumbing Installation

**A** COMPARATIVELY new field for the employment of oxy-acetylene welding is of particular interest to anyone concerned with the construction of buildings. This is the installation of plumbing and heating pipes by means of welding. A number of advantages are claimed for this method and it has given entirely satisfactory results on a number of jobs where it has been used.

The claims are: That the welded joint gives increased strength because of the fact that metal is added instead of being removed, as is the case where threads are cut; it affords a tighter joint, as there are no crevices and the material at the joint is heavier than the rest of the pipe so longer lived under corrosion; the weight is reduced by the elimination of cast joint; appearance is improved and it is possible to apply insulating coverings smoothly; the cost is comparatively low because of time saved in installation and the elimination of any special castings.

In connection with the last item it is pointed out that when welding is used it is possible to make any fitting quickly, right on the job, and that when additions or repairs are required they are most simply effected.

The process is not yet thoroughly understood and many people have mistaken ideas about it. One of these is that when a branch is welded to a main line a hole is large enough to admit the branch and it is then welded in without knowing the amount of its inside projection and consequent obstruction of the main line. As a matter of fact, the branch is not inserted into the main line. It is shaped out to fit the

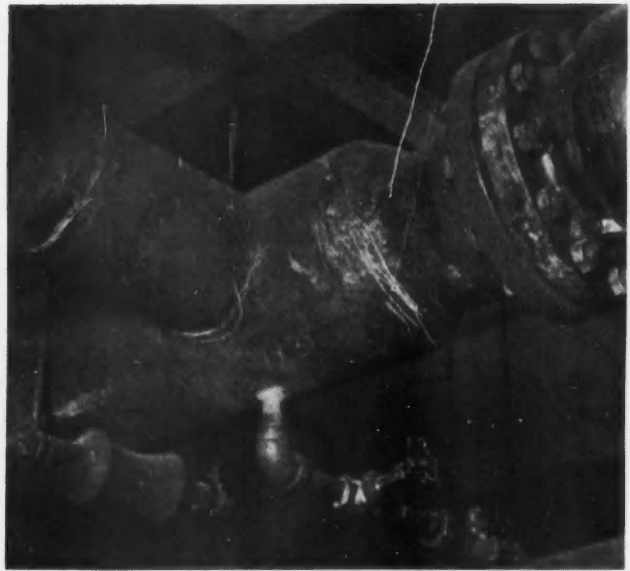

It Is When Making Connections Like This That the Advantages of Welded Plumbing Installation Are Most Apparent. These three joints would be both difficult and expensive if screw connections were used.

contour of the main line pipe and then butted up to it, and its circumference marked on the main line. A hole is then cut in the main line inside of the mark but equal to the inside diameter of the branch pipe. Both the hole and branch pipe are beveled, fitted and welded, giving the equivalent, so far as internal friction is concerned, of a cast fitting.



### Metal Ventilating Brick

**F**OR the ventilation of kitchens, kitchenettes, pantries, bathrooms, closets, hung ceilings or any place where vertical vent shafts and bulky ventilators cannot be used or are undesirable, a new ventilating brick has been developed. This is a metal device of the size of an ordinary brick. It has a louvered face with a weatherstrip at the top, which is transformed to a three-inch diameter pipe at the inner end. It is laid in the wall in the place of a brick.

The ventilator measures 13 inches from the louvered face to the end of the three-inch pipe, but can be supplied in other lengths by special order. It is made of cast iron or bronze with a heavy galvanized iron flue. When installed it is placed in the masonry at a point six inches below the bottom of the ceiling beam with the louvered face at the outer surface and the round pipe in the room.

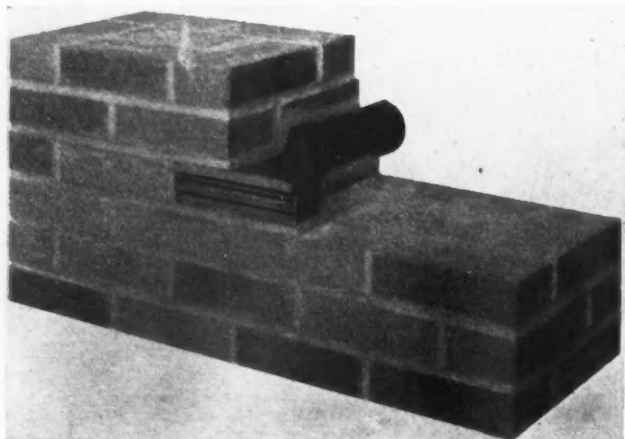

In Laying the Brick Wall This Metal Ventilating Brick Simply Replaces One of the Bricks in the Face of the Wall. It is neat and inconspicuous.

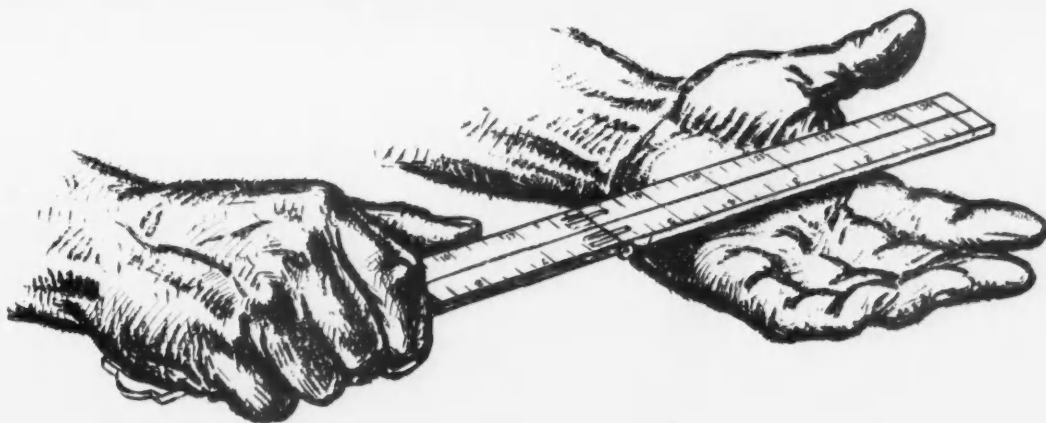

# There is No Rule of Thumb

There is no ordinary builder's rule-of-thumb that you can use in the selection of wood finishes. You can't see knot holes in them as in a piece of lumber. You can't measure or weigh them like a piece of prepared roofing. You can't tell by the "feel" of a varnish how long it will wear.

But the name "JOHNSON" on any wood finish is always a safe rule to follow. It guarantees *quality*.

We are not "paint manufacturers." We are wood finishing specialists.

We know the architects', the builders', the painters' problems—and Johnson materials solve these problems because they are the result of forty years' practical experience, plus the finest laboratory and manufacturing facilities in the world.

**Specify Johnson's; Use Johnson's; Insist on Johnson's**

*Varnishes, Enamels, Wood Dyes,  
Flat Wall Finish, Fillers, Waxes*

## S. C. JOHNSON & SON

*"The Wood Finishing Authorities"*

**Dept. A. B.-3, Racine, Wisconsin**

**Brantford, Can.**

**West Drayton, Mddx., Eng.**

**Sydney, Aus.**

### JOHNSON BRANCHES

**CLEVELAND**  
7106 Superior Ave.  
Phone: Randolph 1826

**DENVER**  
1846 Arapahoe St.  
Phone: South 6269W

**DES MOINES**  
1435 W. 29th St.  
Phone: Drake 8233

**DETROIT**  
3155 Grand River Ave.  
Phone: Glendale 4780

**KANSAS CITY**  
611 Delaware St.  
Phone: Victor 2159

**LOS ANGELES**  
1151 Santee St.  
Phone: Vandike 4196

**LOUISVILLE**  
623 W. Market St.  
Phone: City 6943

**MILWAUKEE**  
864 Third St.  
Phone: Lincoln 912

**NEW ORLEANS**  
508 Magazine St.  
Phone: Galvez 389

**NEW YORK CITY**  
46-48 Lispenard St.  
Phone: Canal 7593

**OMAHA**  
1818 St. Mary's Ave.  
Phone: Atlantic 1634

**PHILADELPHIA**  
401-403 Commerce St.  
Phone: Market 1674

**SAN FRANCISCO**  
1250 Folsom St.  
Phone: Hemlock 1150

**ST. LOUIS**  
19 So. 3rd St.  
Phone: Olive 9416

**ST. PAUL**  
1600 University Ave.  
Phone: Midway 2822



FREE—The Johnson Manual on Wood Finishing. Written by experts for the practical man. An invaluable hand-book for architects, builders and painters. Gives proper methods to use, covering capacities you should get, etc. Used in many American schools as a text book. Send in this coupon for your copy.

Name.....

Address.....

City and State.....

Local Dealer's Name.....

### Magnetic Brad Set

**A** MAGNETIC brad set is a convenient tool for pattern makers, carpenters, cabinet makers, glaziers and anyone who needs to drive brads. The metal shaft is hollow and sliding and contains a magnetic rod. The brad is placed in the end of the set or, if one hand is engaged in holding a piece in place, the barrel is grasped between the first and second finger and pulled back until the magnet is exposed, when it will pick up the brad. The set is then placed against the point where the brad is to be driven and the brad pushed into place. No nailset is required, as this tool sets the brad far enough beneath the surface to cover with putty or wax.



### Electric Steam Radiators

**M**ODERN homes, all over the country, are rapidly being electrified. New appliances and fixtures are constantly being brought out and improved so that electricity can be applied to practically every feature of the home where light, heat or power is needed. It has long been felt that electricity would be ideal for general heating as well as for small, special heating appliances, and the development of this idea is being carried forward.

The electric steam radiator is an accomplished fact and can be obtained in a number of sizes for permanent installation on the floor or wall, or portable, to be moved from one place to another.

These units consist of a cast iron radiator fitted with extra size nipples at the bottom, into which the heating element is fitted. This element extends through the entire radiator, assuring even heat in every column. A three heat switch is made a part of each radiator. The heating element is enclosed in a seamless brass tube which protects it and provides a large radiating surface for heating the water which surrounds it.



The Electric Steam Radiator Marks a Forward Step in the Heating of Homes and the Application of Electricity to Home Requirements.



It Enables You to Pick Up, Place and Set Brads with One Hand, Leaving the Other Entirely Free.

These radiators are also supplied with a thermostat having a range from 50 to 80 degrees. This gives an automatic control, insuring economy and uniform room temperature. In the matter of cost, the practicability of electrical heating has been greatly assisted in the last two years by reductions of rates for current and the increasing cost of fuels.



### Portable Combination Woodworker

**S**INCE lumber stock is furnished in prepared widths and thicknesses the contractor and builder is required to do a deal of cutting and mitering, on the job, as quickly and accurately as possible. A machine which has been designed to supply most of the builder's needs in this line of work is available at a low cost and in a form which is readily moved from place to place.

This comprises a variety saw table complete in every respect. It has a tilting table, 30 by 36 inches, a pair of graduated miter gauges, an adjustable rip fence, ripping as



Most of the Builders' Woodworking Needs, on the Job, Will Be Taken Care of by This Portable Combination Woodworker Which Is Available at Low Cost and Is Easily Moved from Place to Place.

wide as 15 inches, a ball-bearing arbor and graduations under the table showing the angle of tilt. At the right-hand side a jointer is mounted. The jointer knives are of high speed steel, six inches long and mounted on a round safety cylinder. The jointer is also provided with an aluminum spring guard and can be started and stopped at will.

On the rear of the machine is mounted a two-horsepower motor, which drives both the saw bench and the jointer with one belt. The jointer is stopped by turning the hand wheel on the front, thus drawing the jointer pulley away from the belt. The saw bench runs all the time whether or not it is in use.

A curved splitter with an overhead cover guard is supplied with the saw bench. A three-wheel lift truck can be furnished. This truck has ball-bearing wheels and will lift the machine clear of the floor and permit it to be used anywhere. The equipment includes a pair of 12-inch saw blades, a rip and a cross-cut.



### Largest Weatherstrip Contract

**W**HAT is claimed to be the largest weatherstripping contract ever made was recently placed by the Metropolitan Life Insurance Company for its new housing development in Long Island City, Astoria and Woodside, Long Island, N. Y. The Metropolitan Housing Development was fully described in the June, 1924, issue of the AMERICAN BUILDER. The contract secured by the Hoffbauer Company, Inc., New York City, for weatherstripping 14,000 windows, is being completed within a period of five weeks.



# All These Books for 65 Cents

*a complete library on home building*

## Get This Newest Book

**S**IXTY-TWO NEW HOMES, in picture and plan, for every locality—many especially suitable for California, the West and Southwest, two-story singles, two-families and double houses.

The best variety and the latest styles, all in this newest book just off the press. Beautifully printed in rotogravure. Each designed by a well-known architect for beauty and economy. Working drawings at nominal cost for every home shown. *10 cents a copy for "The Home You Can Afford."*

### Your Next Home

THE FIFTY-EIGHT HOMES shown in picture and plan in "Your Next Home" do not duplicate those in the newest book "The Home You Can Afford." Send for both books. All homes actually built and lived in and designed by capable architects. At ten cents each these two booklets give you 120 brick homes for which working drawings are available at nominal cost.

### Brick—How to Build and Estimate

Illustrations and data on money-saving methods. Valuable tables of material and labor costs. Complete details of Ideal Brick Hollow Wall and latest reports of strength of brick work—25 cents a copy.

### Farm Homes of Brick

Plentiful variety for every locality and family requirement. Full of practical suggestions, for economical and comfortable arrangement. Pictures and floor plans. Price 5 cents a copy.

### Skintled Brick Work

Complete dimension sketches showing how to secure attractive new wall surface effects, developed by Chicago architects with Common Brick. The newest styles, low in cost. 15 cents a copy.

### Send 65c—Get All 5 Books

The Common Brick Manufacturers' Association of America  
2131 Guarantee Title Building, Cleveland, Ohio

Enclose find . . . cents. Please send me the books marked below.

- "The Home You Can Afford" (10 cts.)
- "Your Next Home" (10 cts.)
- "Brick—How to Build and Estimate" (25 cts.)
- "Farm Homes of Brick" (5 cts.)
- "Skintled Brick Work" (15 cts.)

Name . . . . .

Address . . . . .

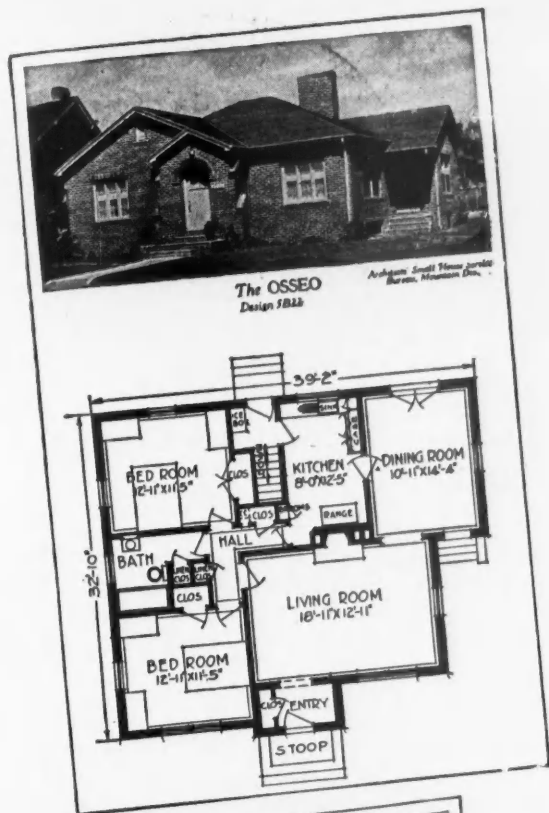

The OSSEO  
Design 1822

Architect: Small House Service Bureau, Mountain View, Cal.

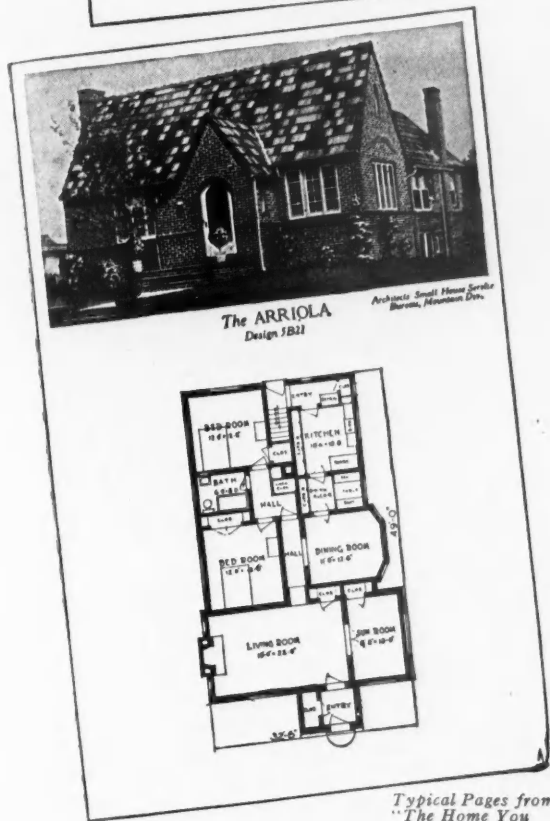

The ARRIOLA  
Design 1821

Architect: Small House Service Bureau, Mountain View, Cal.

Typical Pages from  
"The Home You Can Afford"

## The Common Brick Manufacturers' Association of America

2131 Guarantee Title Building, Cleveland, Ohio

Further information from any of these branch organizations

California Common Brick Mfrs. Assn.,  
342 Douglas Bldg., Los Angeles  
811 Sharon Bldg., San Francisco

Chicago Brick Exchange,  
614 Chamber of Commerce

Connecticut Brick Mfrs. Assn.,  
226 Pearl St., Hartford, Conn.

Detroit Brick Mfrs. & Dealers Assn.,  
404 Penobscot Bldg., Detroit

Louisiana-Mississippi Brick Mfrs. Assn.,  
904 Carondelet Bldg., New Orleans

The Common Brick Mfrs. Assn. of Amer.,  
Room 1710 Grand Central  
Terminal Bldg., New York

Pacific Northwest Brick Mfrs. Assn.,  
524 Burke Bldg., Seattle

Tennessee-Kentucky Brick Mfrs. Assn.,  
174 3rd Ave. North, Nashville, Tenn.

Ohio Brick Mfrs. Assn.,  
2124 Guarantee Title Bldg., Cleveland

WHEN WRITING ADVERTISERS PLEASE MENTION THE AMERICAN BUILDER

### New Adjustable Insert for Machine Mounting in Concrete

FOR the purpose of fastening machinery or other equipment to concrete floors, walls or ceilings without the disadvantages attending the use of bolts embedded directly in the concrete, a new adjustable bolt insert has been designed.

When bolts are embedded directly in the concrete, unless extreme care is exercised, they do not register correctly with the mounting bolt holes of the apparatus to be installed and hence the bolts have to be bent or forced into position, with a consequent mutilation of the threads, or the mounting bolt holes reamed.

The new insert permits an adjustment of the bolt position after the concrete has set and results in more satisfactory machine mounting. The adjustable insert consists of a cast-iron housing with a tapering body and containing a rotatable bolt carrier. The bolt carrier is T-slotted to take the head of a standard machine bolt and is of sufficient length to permit a  $\frac{5}{8}$ -inch movement of the bolt from the center.

Since the carrier can be rotated, the adjustment of the position of the bolt can be secured in any direction. The housing and bolt carrier are provided with teeth which mesh and prevent any change in position after the adjustment has been made and before the bolt has been tightened. The teeth are kept in mesh by a retaining spring which is held in by a sheet metal plate at the back of the housing.

When the insert is to be installed, the form for the concrete is drilled at the point desired for the bolt. The insert is then fastened tightly to the form by a bolt run through the form and screwed into a nut placed in the T-slot of the bolt carrier. After the concrete has set for a suitable length of time, this bolt and nut are removed and a bolt of the proper length is placed in the bolt carrier which is rotated until the bolt is in the correct position to receive the base of the apparatus to be mounted. The nut is then tightened on the bolt and the location is fixed.

These inserts, which are available for  $\frac{3}{8}$  or  $\frac{1}{2}$  inch machine bolts, have great holding power when embedded in concrete, due to the fins and flange which are cast as an integral part of the housing. The holding power of the combination equals the ultimate strength of the bolt.



### Electrical Outlet Frame

A N electrical outlet frame, just perfected, enables electrical mechanics to do a quicker, better and more lasting job of installing outlet boxes and saves contractors considerable time and money on all wiring jobs.

This frame is made of wood and consists of six pieces, two cleats for nailing to studs, two cross-pieces, plough-grooved, and two sliding uprights to hold laths and outlet boxes in place. Nails and screws are furnished with each frame.

With it an outlet box can be installed complete in 10 minutes or less. There is no measuring to be done and no metal clamps to get broken. Everything is handy, ready for use when needed, and when installed, frame and box are absolutely secure.

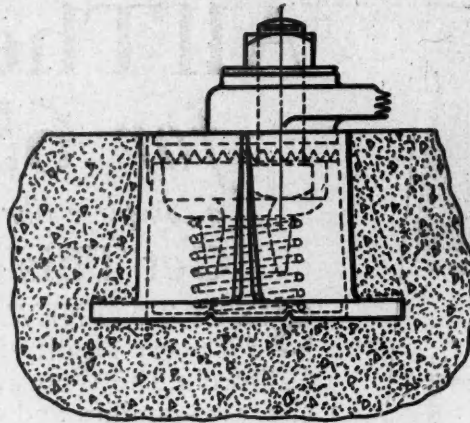
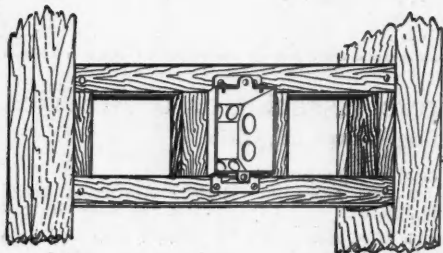
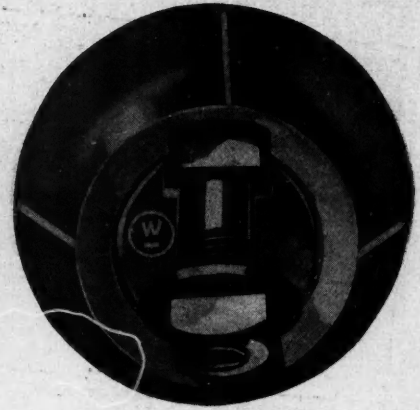

Diagram Showing the Insert Embedded in Concrete with the Bolt in Adjusted Position and Tightened Over Machine Base or Foot.



The New Adjustable Bolt Insert, Showing How the Bolt Is Placed in the Slot.

The frame can be used for ceilings, sidewalls, baseboards, or any other place where an outlet box is needed. The time it saves the contractor will more than pay for its cost.



### Electric Power Eraser

COMBINING erasing and power elements in one unit, weighing less than two pounds, an electrical eraser for use of architects, draftsmen and others, with particular application to those associated in the building industry, has

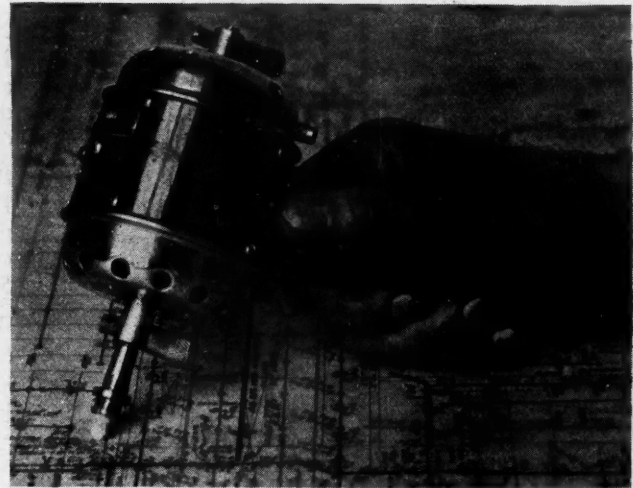

A Real Convenience, Where Much Erasing Is Necessary, Is This Light Weight Power Eraser Which Combines Erasing and Power Elements in One Unit.

recently been invented, and placed on the market. It is designed to eliminate objectionable features of cable machines, as the entire weight rests on the drawing surface.

The machine is so constructed that, with it, a mark as small as a period may easily be removed from paper without touching marks surrounding it. The machine is held at an angle of 45 degrees when in use. The revolving motor armature produces a gyroscopic action, which tends to hold the device at the correct operating angle without extra effort on the part of the user. Since the hold hand grasps the handle and the weight is on the drawing surface, it is necessary only to guide the device when operating it.

The one caution advanced by the maker of the machine is that an erasing shield should be used by a person operating the device for the first time and that the machine should be kept in motion. Only one hand is used for the operations, leaving the other hand free to handle other marks on the paper. Erasers are supplied in various qualities to be used in the machine.—R. G. THACKWELL.



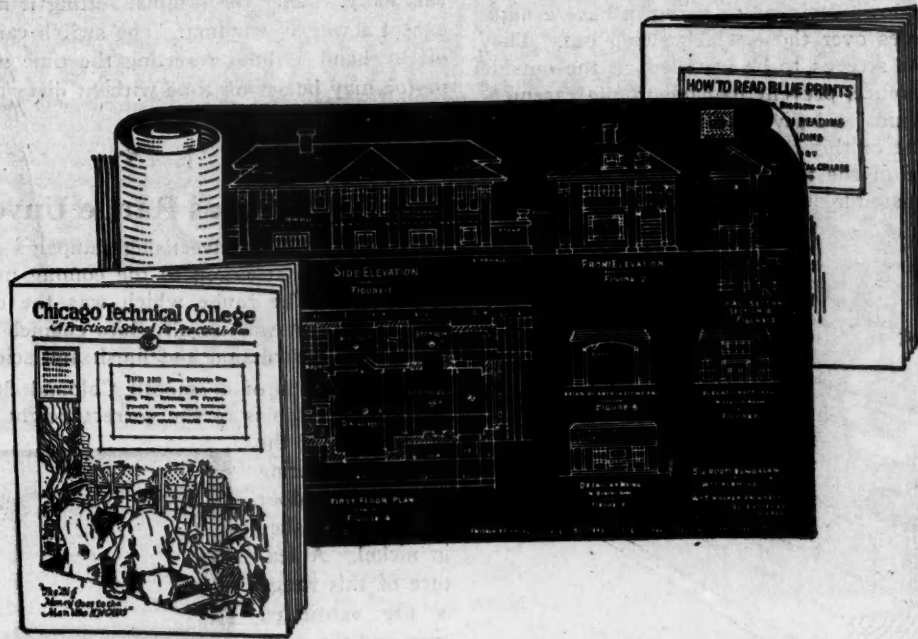

# SENT FREE

## Mail the Coupon for These Two Books and Blue Print Plans

If you are in any building trade, we want to send you these 2 books and blue prints at our expense. One of these books contains a lesson in Plan Reading prepared by the Chicago Tech. experts; the other explains the Chicago Tech. method of training men by mail in the building trades for the jobs that pay the most money or for businesses of their own. All you have to do to get them is to mail the coupon. Don't send a penny.

## Get the Knowledge That Will Make You Worth More Money

You may be as good a man as there is in the use of tools but as long as you remain a workman you won't earn more than the wage scale. It isn't manual skill that puts a man in big pay class—it's the ability to use his head that brings the fat pay check or enables him to "go in for himself." That has been proved over and over again by workmen who took the Chicago Tech. training in the higher branches of building and are now foremen, superintendents and contractors.

J. B. Woodside of Oklahoma was a carpenter working for \$6 a day when he took a course in training by mail at Chicago Technical College and was advanced to a foremanship in 2 months, became a superintendent 5 months later and then went into contracting.

Carl Testroat of Iowa is another man who got into a successful contracting business through his training, as did J. G. Hart of West Virginia, and C. W. Busch of Kansas.

Not only workmen have got ahead through this instruction but also contractors who were taking on small jobs because their experience was limited. Chicago Tech. has taught them how to handle the big jobs that pay the most money.

### Train by Mail

Never before have there been such opportunities as there are right now for men with expert knowledge of building. You can get ready for these big opportunities if you will use some of your spare time to study at home under the direction of the Chicago Tech. experts. No time taken from your present work. All this will be explained when we send you the free books and blue prints.

### Become a Building Expert

*Plan Reading.* Every man who has got very far ahead in any building trade can read blue prints. No man

can expect to be a first rate foreman or superintendent until he knows what every line on a plan means and how to lay out and direct work from the architect's plans. By the Chicago Tech. Method you quickly learn to read any plan as easily as you read these words.

*Estimating.* Of course a man who wants to be a contractor or to hold a big job in a contracting organization must know how to figure costs of labor, material, and everything else that goes into any kind of building. The Chicago Tech. course covers every detail of this important branch—shows you just how it is done from actual blue print plans.

*Superintending.* How to hire and direct men, how to keep track of every detail of construction as it goes on, how to get the work done in the least time at the lowest cost is also fully covered in the Chicago Tech. Builders' Course.

Also special courses in Architectural Drafting for builders, taught by practical men. These explained in Special Catalog "D" sent on request.

### Mail This Coupon—Today

**CHICAGO TECHNICAL COLLEGE,**  
Dept. 336, Chicago Tech. Bldg.,  
118 East 26th Street,  
Chicago, Ill.

Please send me your Free Books and Blue Prints for men in the Building Trades. Send postpaid to my address below.

(Write or print name plainly.)

Name .....

Address .....

City ..... State .....

Occupation .....

## CHICAGO TECHNICAL COLLEGE

Dept. 336, Chicago Tech. Building, 118 East 26th Street, Chicago, Ill.



### Weatherstrips Inswinging Casements

CASEMENT windows designed to swing in have a number of advantages over those which swing out. They allow storm sash or screens to be installed on the outside without any interference, prevent damage to the casement in case of heavy winds and give the full window area for ventilation. In spite of this they have never been entirely satisfactory because of the fact that in using them it was difficult, if not impossible, to eliminate leaky sills. This

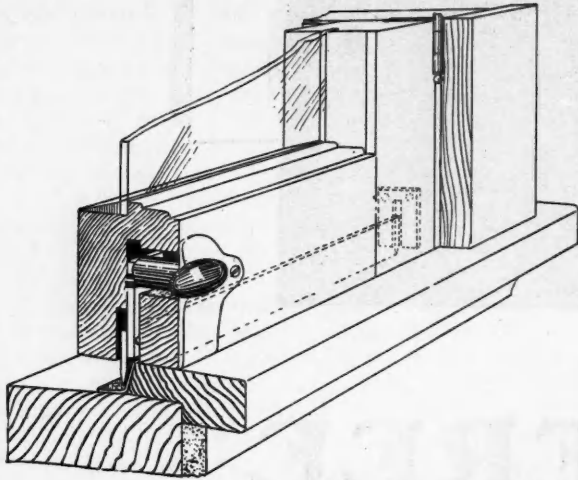

The Simple Construction and Operation of This Weatherstrip for Inswinging Casement Windows Is Shown in the Sectional View Above. Only the knob is visible in this installation.

disadvantage is overcome by a type of casement window hardware particularly designed to accomplish that purpose.

This appliance is a metal strip set into the bottom of the sash and operated up and down by means of a knob. As this brass strip slides down it forms a snug contact with a zinc strip along the sill, completely sealing the joint. At the same time it serves as a window lock. The appliance is controlled through an eccentric movement, with no springs, by a half turn of the knob. This appliance is simple and easily installed and is very durable.



### Electric Timers and Clocks

TIMED control of electrical circuits is rapidly attracting more and more attention, and being adapted to new uses. A line of automatic timers and clocks was originally designed to control the window lighting of stores where, because of the well-known advertising value of window display, the value of good lighting at regular times was well known. Other uses for these fixtures have become evident.

They are now used for the control of electrical appliances in homes and apartments, for street and park lighting, traffic signals, on the farm, for controlling water supply pumps and such equipment as separators, in stores for lighting by departments, for night lights in banks and similar institutions.

The timer simply turns "on" and "off" (or "off" only if desired) at any desired time. It is only necessary to set the painter and cock the switch. It operates once only within 12 hours after setting and must be set every day.

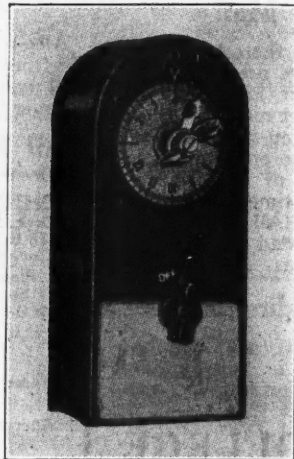

This Automatic Timer Will Control Any Electrical Circuit.

The clock is designed to control circuits at regular intervals daily. After the original setting it needs no attention except a weekly winding. The switch can be turned on or off by hand without resetting the time motor or the time motor may be set on time without disturbing the times set for operation.



### New Gas Range Unveiled

RECENTLY an advertising campaign all over the country called attention to the coming unveiling of a new gas range. The range which was the object of a great deal of interest was an all white enamel model embodying beauty of construction and finish and scientific design.

This range is of a smooth Colonial flush finish design. The cooking top is of the correct height to save stooping in any part of the work of preparing a meal. The door frames are finished in nickel. A feature of this range is the ventilated oven and the oven control which give complete control of oven temperature at all times and, according to the manufacturer, increases oven efficiency 18 per cent, at the same time effecting a saving in fuel consumption.

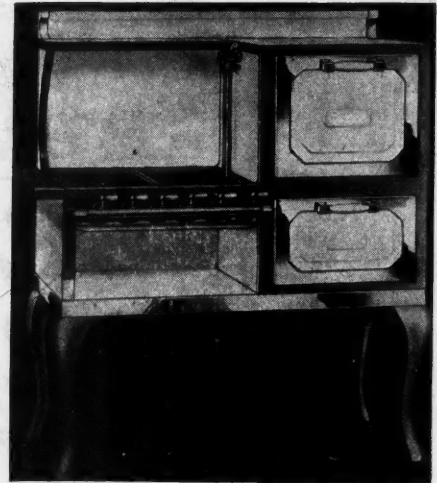

An All-White Enamel Gas Range Which Features a Ventilated Oven and Oven Temperature Control.



### Wood Preserving Stain

A PATENT, antiseptic compound with an attractive chestnut brown color is the most recent newcomer in the field of wood preservatives. It is an oily substance, containing no pigment, but staining the wood a rich brown. It will not peel, blister, scratch or wash off, and protects the wood against dampness, rot decay and fungus growth. The wood to be treated can be dipped or the liquid can be applied with a brush.

Its covering capacity is about 300 square feet per gallon, per coat, and three brush coats should usually be applied. It is always ready for use as it comes, except that in cold weather or where a surface will receive very hard wear it is better to apply the material hot. It soaks into the wood, destroys the albuminous matter which is the cause of rot and decay, and leaves the pores open.

This material has highly antiseptic and disinfecting properties, containing about 60 per cent crude carbolic acid. It can be easily applied to any woodwork and requires no special skill or knowledge, but the treatment should always be thorough. Three coats are applied at intervals of 24 to 48 hours. For interior work, to obtain a wax or dull gloss finish, each coat is rubbed down about one hour after application, with clean cheese cloth, until no more material rubs off. The surface to be treated should always be thoroughly clean and dry before the application is made. A silver brown effect can also be obtained for interior work by applying a light coat of white paint, following the three coats of preserver and rubbing off before the paint dries.

# Floor Surfacing Jobs Insure Steady Income

## KEEP THE MONEY ROLLING IN THE YEAR 'ROUND

The progressive contractor and builder has found a way to increase his yearly income by keeping busy all the year 'round. When building is at a standstill and there are no profits coming in, he makes \$25.00 to \$50.00 a day resurfacing old floors with the "American Universal" electrically driven floor surfacing machine. It does the work of six men and earns six men's pay.

Add  
**\$5000**  
To Yearly Profits

### Big Demand for This Class of Work

All new buildings have to have their floors surfaced and smoothed, and old worn floors should be resurfaced. It is a well known fact that there will be more new building done in 1925 than any previous year. This means more business and a big year for the contractor.

Work Easy to Get with an

## American Universal FLOOR SURFACING MACHINE

The beautiful smooth, uniform work which the "American Universal" floor surfacing machine turns out puts the most expert hand scraper's best efforts to shame. There is absolutely no comparison.

### Who Stands a Better Chance Than You?

You know the owners of buildings and homes where floors require resurfacing. You are acquainted in your community and this will make it easier for you to land the contracts for resurfacing the great number of old floors in your locality which are in need of it (and badly so) right now.

### An Investment Worth \$5,000 a Year to You

An "American Universal" floor surfacing machine is always a good investment. It will replace six men on your payroll during the building season—and turn loss into big profits during the dull seasons. One fair sized job pays for the machine.

### Let Us Tell You How

Write today or fill out this coupon and we will furnish you with full information without any obligation on your part.

**The American Floor Surfacing Machine Co.**  
515 South St. Clair Street : : Toledo, Ohio



### MAIL COUPON TODAY

The American Floor Surfacing Machine Co.,  
515 South St. Clair Street., Toledo, Ohio

Please send me without any obligation on my part full information about the "American Universal" Floor Surfacing Machine.

- I am a building contractor.
- I am interested in becoming a floor surfacing contractor.

Name.....

Street.....

City.....

State.....









## New Super-Size Shingles Make Wonderful Roofs

Barrett Giant Shingles! Here's an improved super-size shingle that never fails to please the most critical home owners.

Barrett Giants (12 x 14 inches) are thicker than ordinary shingles. On re-roofing jobs they can be laid right over the old roof.

*More economical.* With their 12-inch width—the maximum width that can be fastened satisfactorily with two nails — fewer Barrett Giants are needed per square. (The experience of roofers has proved that it costs almost 50% less to lay Giants than ordinary shingles.)

*Artistic.* Barrett Giants are handsome. Surfaced with slate in fadeless colors—red, green and blue-black—they never need painting or staining.

*Fire-safe.* These shingles are fire-safe — proof against flying sparks and embers. That means lower insurance rates.

### A Business-Building Book

"Better Homes from Old Houses" is packed with suggestions for remodeling old-fashioned houses. Send a copy to the people in your town who own old houses. And follow it up! Write for *your* free copy.

**Mineral-Surfaced Shingles**  
(Green Red Blue-Black)  
Everlastic Giant Shingles  
Everlastic Single Shingles  
Everlastic Multi-Shingles  
Everlastic Octagonal Shingles

**Roll Roofings**  
Everlastic Smooth-Surfaced  
Everlastic Mineral-Surfaced  
(Green Red Blue-Black)

# Barrett ROOFINGS

THE BARRETT COMPANY, 40 RECTOR ST., NEW YORK

In Canada: The Barrett Company, Limited  
2021 St. Hubert Street, Montreal, Que., Canada

MAIL THIS COUPON TODAY

**THE BARRETT COMPANY**  
40 Rector St., New York

Please send me free sample copy of your business-building book — "Better Homes from Old Houses." The address of my building supply dealer is given below.

Your Name .....

Street Address .....

Town..... State.....

Your Dealer's Name .....

Dealer's Address .....

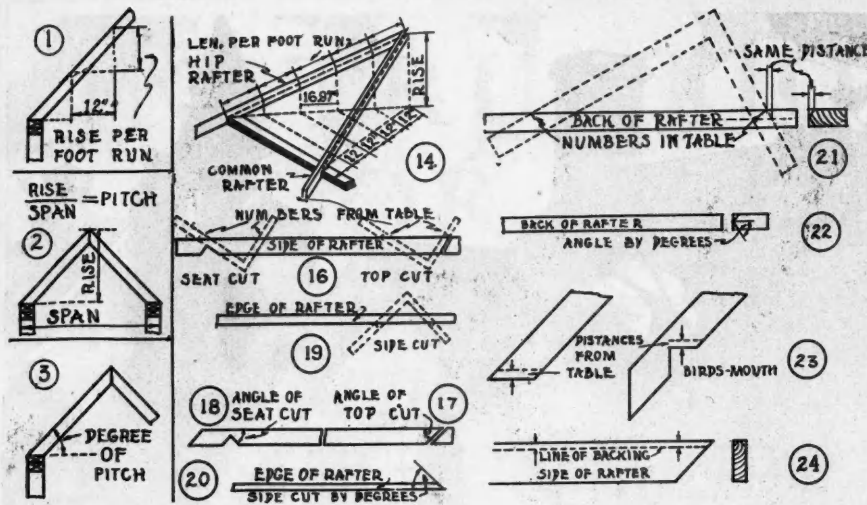

Explanation of the Various Cuts Listed in the Diagrammatic Chart Shown on Page 184.

18. **Bottom cut by degrees.** This column is similar to No. 17 except that it gives the bottom or seat cut of the rafters. It should be noted that if you add together the bevel given for the top and bottom cut in degrees you obtain 90 degrees in each case. Therefore, if you have either the top or bottom cut given in degrees you can obtain the other by subtracting from 90 degrees. For a one-third pitch roof, the top cut by degrees for the hip rafter will be 64 degrees and 48 minutes. The seat or bottom cut will be 25 degrees and 12 minutes.

19. **Side cut by square.** As the hip rafter also has a bevel cut at the top, this column gives the numbers to be used on the square to obtain this bevel as illustrated in Fig. 20. For a one-third pitch roof, the numbers used on the square to obtain the bevel are 79 and 17 marking along the arm of the square on which the 19 is taken. In all cases we mark on the arm of the square on which the larger number is taken when laying out the side cut. This column is based on the rule that the side cut of the hip rafter is obtained by taking the length of hip rafter per foot run on one arm of the square and the run of hip rafter per foot run of common rafter on the other arm of the square.

20. **Side cut by degrees.** This column gives the bevel of the side cut for the hip rafter by degrees. The angle is laid off on the back of the rafter. See Fig. 20.

21. **Backing hip by square.** Take the numbers given in this column and apply the square to the back of the hip rafter as in Fig. 21. The angle that the square makes with the edge of the rafter gives the angle of backing. The illustration shows how the distance is laid out on the side of the rafter.

22. **Backing of hip by degrees.** In this column the angle of backing for each pitch is given by degrees. Note that the angle is taken on a section straight across the rafter.

23. **Vertical drop of hip if unbacked.** Very often the hip rafter is not backed. In such cases the seat should be cut out further so that the rafter is lowered thereby bringing the edges of the hip rafter in the same plane with the common rafter. The distance to be lowered varies with the different pitches. This column gives the distance for each pitch. The dotted lines in Fig. 23 show where the cut should be made. Two kinds of rafter ends are shown.

24. **Distance from edge to line of backing.** The numbers in this column will simplify the method of obtaining the amount of backing. All that is needed in this case is to take the distance as given in this column for the desired pitch, and measure on the side of the rafter from the edge to the line of backing as shown in Fig. 24.

### Problems

1. A hip roof is 20 feet wide and has one-half pitch, what is the length of the hip rafter if no ridge board is used (not including the tail end)?
2. What is the length of the rafter if a 1½-inch ridge board is used?
3. What numbers on the square will give the top and bottom cut?
4. What is the angle of the top cut in degrees?
5. What is the angle of the seat cut in degrees?
6. What is the angle of the side cut in degrees?
7. What numbers on the square will lay out the side cut?
8. What is the angle of backing in degrees?
9. What is the vertical distance that the hip rafter should be dropped if it was left unbacked?

10. What is the distance from the edge of the rafter to the line of backing?

### Answers

1. The length of hip per foot run of common is 20.78 inches. The length of hip rafter is 20.78 times 10 equals 207.8 inches equals 17 feet 3<sup>13</sup>/<sub>16</sub> inches.
2. The length of this hip rafter if a 1½-inch ridge board is used is 17 feet 3<sup>13</sup>/<sub>16</sub> inches less 1½ inches equals 17 feet 2<sup>7</sup>/<sub>16</sub> inches.
2. The numbers 17 and 12 will give the top and bottom cuts (marking along the 12 for the bottom cut).
4. The angle of the top cut is 54 degrees and 47 minutes.
5. The angle of the seat cut is 35 degrees and 13 minutes.
6. The angle of the side cut is 39 degrees and 10 minutes.
7. The side cut may be laid out using the numbers 21 and 17 (marking along the 21).
8. The angle of backing in degrees is 60 degrees.
9. The vertical distance that an unbacked hip rafter must be lowered is 9<sup>1</sup>/<sub>16</sub> inches.
10. The distance from the edge of rafter to the line of backing is ½ inch.



### Longview Third in Building

LONGVIEW, which is only a little over two years old, was the third city in the state of Washington and ranked ninth in the entire Pacific coast section in building activity for the month of January, according to building permit figures. A report issued by S. W. Straus & Co. places Seattle first in Washington with permits covering an estimated expenditure of \$2,715,790 for the month. Tacoma is second with \$1,007,650 and Longview third with \$285,478.

When taken in consideration that the estimated city and suburban population of Seattle is nearly 400,000 and Tacoma about 150,000 compared to slightly more than 6,000 in Longview, this city's showing is remarkable from a population standpoint. Population of Spokane, which ranks fourth with \$99,065, is 140,000, more than twenty times as great as the population of Longview.



### Ajax Changes Name

ANNOUNCEMENT has just been made that the name of the Ajax Bracket and Outlet Company, manufacturers of metal sheathing and roofing brackets, has been changed to Ajax Building Bracket Company. The address of this company remains unchanged, its headquarters being at 1551 Rydal-Mount Road, Cleveland Heights, Ohio.



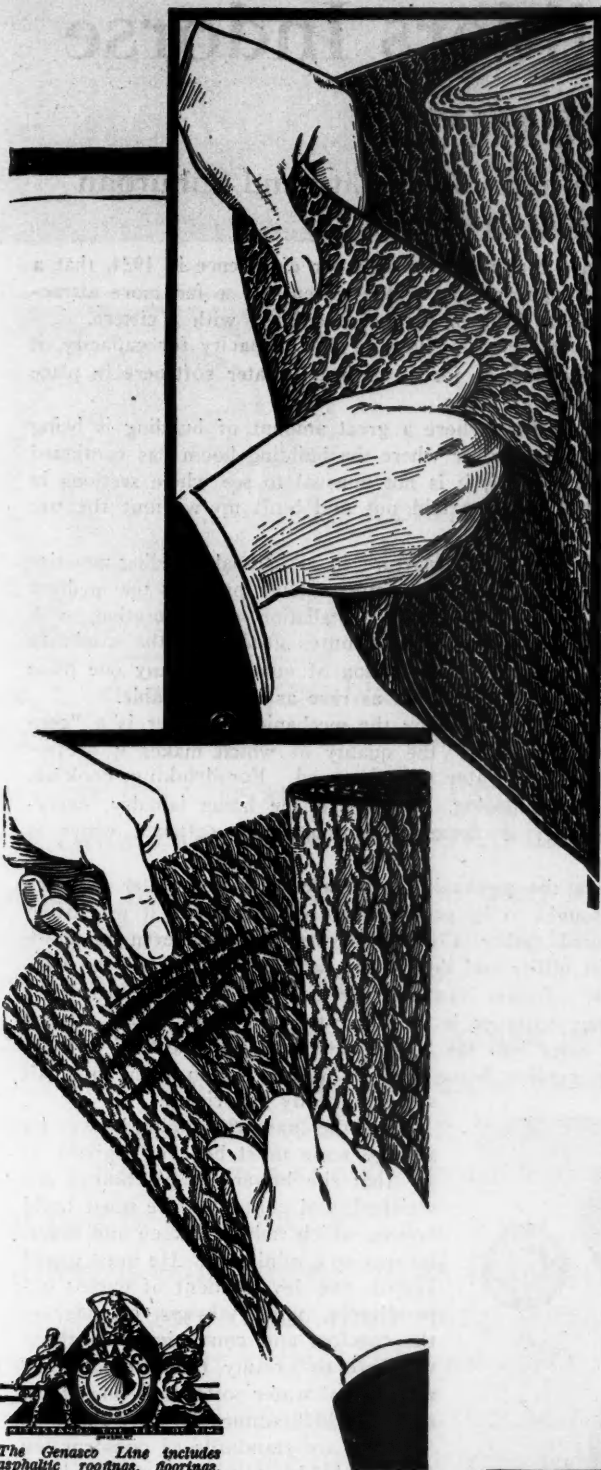

# You can prove the high quality of Genasco Roll Roofing

Take a strip of Genasco Roll Roofing. Bend it! Twist it! Try to pull it apart! You'll be astonished at its tough, pliable, rugged construction.

Then take a sharp knife and scratch the under surface. It is coated on both sides with Trinidad Lake Asphalt Cement—a feature that adds years to the life of your roof.

Experts are not required to make a quick, weather-tight job with Genasco Roll Roofing. The Kant-Leak Kleet, an exclusive GENASCO feature, insures its perfect application even by a novice.

Why use just "roofing" when you can obtain Genasco at *no extra cost*? The Genasco Line provides you with a sturdy, dependable covering—roll or shingles—for any type of building. Write at once for illustrated booklets.

**The Barber Asphalt Company**  
PHILADELPHIA

New York Chicago Pittsburgh St. Louis  
Kansas City San Francisco



The Genasco Line includes asphaltic roofings, floorings, paints, and allied protective products. Write for illustrated folders.

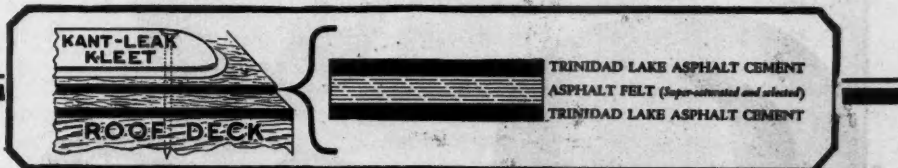

# Genasco

## ROLL ROOFING

Reg. U. S. Pat. Off.

WHEN WRITING ADVERTISERS PLEASE MENTION THE AMERICAN BUILDER



# Contractor and Builders Indorse Water Softeners

Great Help in Selling Houses, Says W. H. Scheiman of the City and Suburban Building Co., Ft. Wayne, Ind.

**T**HE cistern is gradually being eliminated as the source of soft water supply in homes throughout the hard water regions of the country, and here's the reason.

It costs too much, capacity for capacity, as compared with the mechanical water softener.

Hygiene cites the evil of this filthy, stagnant storage pool; medical authorities lambast its disease spreading agencies; chemists who have analyzed cistern water broadcast warnings from the house tops, but the contractors and builders of America, in full recognition and appreciation of the cistern's effect on health, have their own reasons for installing mechanical water softeners to provide soft water in homes they are building.

They see it now as a factor greatly increasing the salability of their homes. They have come to realize, too, that, capacity for capacity, the mechanical water softener is cheaper than a cistern.

No less an authority than W. H. Scheiman, general manager of the City and Suburban Building Company, of Fort Wayne, Indiana, one of the largest concerns of its kind in that section of the country, declares that the water softener opens up a new era of economy and efficiency in home building, from the standpoint of first cost as well as in consideration of the constant expense that always attends the construction of a cistern.

The building program of the City and Suburban company for 1925 contemplates the erection of at least 50 homes, and this number may be increased by 25 if conditions are at all favorable, Mr. Scheiman says. In this year's building campaign, he says, the City and Suburban Company will use more mechanical water softeners than ever before.

"We are convinced, through our experience in 1924, that a home equipped with a water softener is a far more attractive home to a buyer than one equipped with a cistern.

"Our cost records show us that, capacity for capacity, it is actually cheaper for us to install water softeners in place of cisterns."

In those cities where a great amount of building is being done at this time, or where the building boom has continued for several years, it is not unusual to see whole sections in residential districts laid out and built up without the use of a single cistern.

This rather new departure in residential building practice is self explanatory. The water softener provides the medium of combining economy of installation and operation, with service of quality and contributes greatly to the salability of homes. Such a combination of qualities in any one piece of household equipment is as rare as it is desirable.

The water provided by the mechanical softener is a "general purpose" water, the quality of which makes it preferable wherever water is to be used. For drinking, cooking, bathing, shampooing, shaving, in the home laundry, everywhere water is demanded, mechanically softened water is used.

Before the mechanical or "base-exchange" water softener was brought to its present stage of perfection, it was often considered rather a costly device, although even in those days its utility and desirability largely counteracted the item of cost. Today, however, the cost of the perfected base-exchange softener is on a parity with many other articles which enter into the construction and equipment of a thoroughly modern home, and its upkeep is an item so small as to be really surprising.

Since the man who builds houses on a large scale must be ever vigilant to see that the buyers of his homes are satisfied, and contented, he must build houses which reduce upkeep and maintenance to a minimum. He must guard against the development of excess expenditures, while always considering the comfort and convenience of those who are to occupy the homes. The mechanical water softener is one of the devices which admirably serve this end.

There are standards of construction to be upheld. There are standards of equipment to be borne in mind and adhered to, but the features that stamp the modern home as being especially desirable are the refinements here and there that distinguish it from the ordinary run of homes the world over.

Obviously, the builder who wishes to sell his houses rapidly, if he builds on a large scale, must cultivate and safeguard the satisfaction of his buyers. One disgruntled occupant of one of his homes can do much to destroy the salability of other houses he has built.

But consider the satisfied home owner. He is the symbol of a builder's success. He is the living, breathing,

(Continued to page 192.)

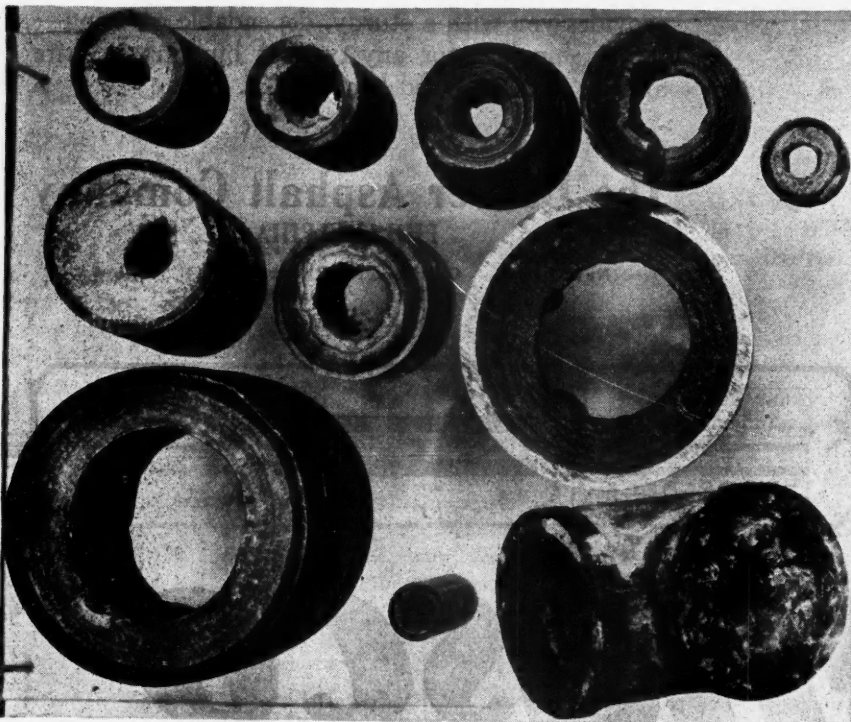

Here Is One Reason Why the Water Softener Is a Decided Advantage. The tremendous reduction of capacity, due to heavy scale deposits in these  $\frac{3}{4}$  to 4-inch galvanized steel pipes could have been prevented by the use of a water softener.



## CONCRETE MADE WITH ATLAS PORTLAND CEMENT IS THE COMPLETE ARCHITECTURAL MATERIAL

Concrete is "a new and more perfect tool, better balanced to the economics of our time than any other building material." Never before was the variety of form, enrichment in color, that architecture of past ages secured only through lavish expenditure, economically possible in today's construction. Concrete, made with Atlas Portland Cement, now opens a new era of architectural achievement.

Concrete has substance. The Panama Canal, the tunnels, bridges and skyscrapers of our large cities, have tested and proved its strength. No other material can take its place.

Concrete has form. It can be used for simple foundations and walls, or it can shape itself to elaborate columns, cornices, and even complete sculptural masterpieces, like the Fountain of Time, in Chicago.

Concrete now has color. No longer need fading and impermanent surface colorings be recurrently replaced. For by using naturally colored sands and stones with Atlas, either in its normal gray tone or in pure white, any range of color can be secured, from delicate tints to rich and sumptuous tones. And such color is an integral and permanent part of the concrete.

Concrete is economical. Atlas improvements in manufacture make Portland Cement actually cheaper today than thirty years ago, adding, to concrete's complete structural service, economy provided by no other material.

The architect, the contractor, the home builder, have now available in Atlas Portland Cement the complete architectural medium—permanent, adaptable, beautiful and economical, "the Standard by which all other makes are measured."

*Between the Atlas plants and the user there is but one distributor—the building material dealer—who brings Atlas to the public cheaper than by any other method. Any architect, contractor or prospective builder is invited to write this Company regarding the possibilities of concrete, made with Atlas.*



Atlas  
Portland Cement

# The ATLAS Company

## PORTLAND CEMENT

25 BROADWAY, NEW YORK, N. Y.

CHICAGO      BIRMINGHAM      INDEPENDENCE, KANS.  
PHILADELPHIA      BOSTON      ST. LOUIS      DES MOINES      DAYTON      OMAHA  
BUFFALO      KANSAS CITY      JACKSONVILLE, FLA.



Atlas White  
Portland Cement



talking (especially talking), advertisement of the builder's wares. He is the man who spreads the good word to his friends that So-and-So is a mighty fine builder and is a good man to deal with.

The builder who aims at success must shoot at something approaching the ideal. This, in fact, is the age of "ideal homes." In every section of the country where there are progressive, wide-awake builders who always keep their weather eye open for devices which will improve their homes, these "ideal homes" are springing up. They embody all the desirable features of a comfortably luxurious home, while still being within the reach of the average man.

In Cedar Rapids, Iowa, for instance, there has recently been completed what is called the "Ideal Electric Home." It has been built and equipped on a co-operative basis, various contractors and merchants taking part in its construction and equipment.

Of course this ideal home contains a water softener, for the mechanical softener is admittedly ideal equipment for any home. When ideal equipment goes hand in hand with economy, it becomes something greatly to be desired.

Today, as never before in our history, the American public is coming to a realization of the importance of its water supply. Extensive research work is being done all over the country with regard to water purification and allied subjects. In some sections of the country where cisterns are used—and in 65 per cent of the territory of the United States cisterns provide the only source of soft water—there is legislation directed toward safeguarding the users of cistern water from possible disease through contamination of the cistern water.

In apartment houses, where provision of soft water has long been a troublesome item, the mechanical water softener steps into the breach just as if it has been especially designed to solve the problems of the apartment house builder. It is the only possible way to provide a constant supply of soft water in an apartment house.

So varied are the types and sizes of water softeners available today that the smallest homes as well as the largest apartment houses, not to mention great industrial establishment, large hotels, laundries, public institutions and extensive textile mills, may find water softeners to suit their needs.

## How to Select the Right Kind of Plumbing Fixtures

By **KARL WILLIAM ZOELLER**

*Author of "Merchandising the Plumbing Business."*

**I**T may occur to our readers that it is not necessary to know "How to select the right kind of plumbing fixtures," provided one has the price.

But when you stop to consider that 50 per cent and often more of the total plumbing investment is hidden under floors, between the walls or buried in the ground, it immediately is apparent that great care should be exercised in purchases of plumbing supplies.

One bad spot in plumbing installation can easily run up a larger repair bill than the total cost of the whole plumbing job. For that reason the science of Sanitary Engineering as the modern plumber designates his work, is regulated by state and city laws and regulations. Codes, they are called, and are created for the health and welfare of the public.

The plumber has been much maligned in the past for his bad business practices; almost every joke paper has carried stories of the plumber going back to his shop for tools. But the truth of the matter is quite the contrary; the general public have so little knowledge of the details or functions of sanitary work that the plumber is ordered to do a job quite different from that which he finds necessary when he arrives on the scene.

It will also become apparent to builders that it is quite as important to let the plumbing job to a competent plumbing contractor as it is to buy the right kind of fixtures and supplies.

To visualize the innumerable details of what is required to complete a proper plumbing installation would require more space than we have in these articles; but briefly we can enumerate some of the most essential.

Soil pipe to carry off the waste is first, then there are the water supply lines leading into the house; it requires a careful judgment to know the correct size of these in order to insure an even pressure all through the building. We all probably have had experience in the old house where it was impossible to get water when someone downstairs was using it. That fault is eliminated by the correct installation at the time the house is built.

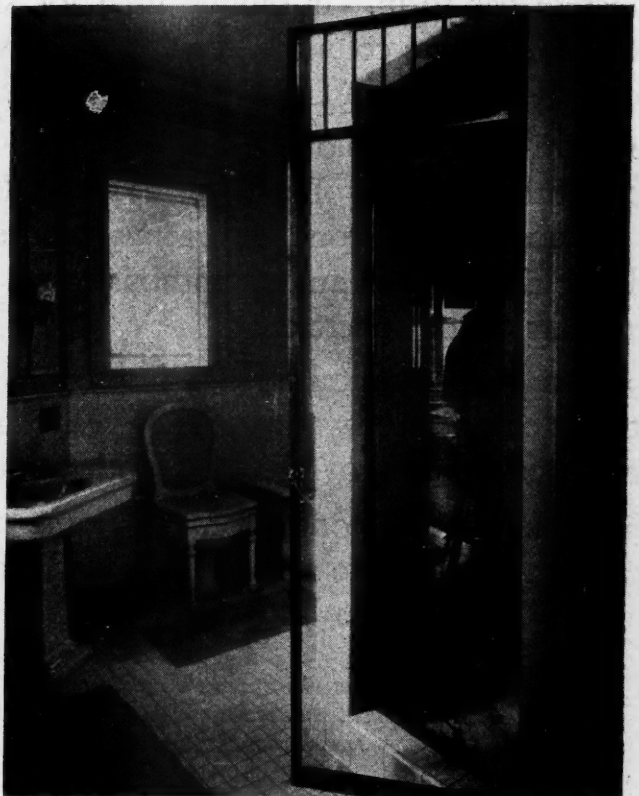

Showers in Separate Cabinets Are a Convenience, the Value of Which Is Readily Apparent, but a Wall Cabinet Through Which the Plumber Can Make Adjustments in the Tub or Shower Connections Is Equally Valuable.

Then there's the matter of risers; it is of the utmost importance that they are correctly sized and properly located to function properly. Faucets, valves and cocks come next; here is a much discussed subject—you'll find these articles offered at a wide range in price, but we



believe you will agree with us that in as important an item as this, only the best is cheap.

Many of the valve manufacturers are now telling their story in the public prints and builders can get a good idea of their comparative values by reading these advertisements.

Vents are important from a health angle and it is a fine point of plumbing engineering to handle this detail correctly. It is through the vents that the gases and odors escape.

There is usually a cabinet placed, either in the bathroom wall or just outside, through which the plumber may easily make adjustments in case of trouble to the bath tub or shower bath connections.

In one of the preceding articles we have spoken of hot water heaters, which are the source of much comfort and convenience to the household. The fixtures have all been described in our second article. We said of them that it is not difficult to buy good looking fixtures because you can see your purchases, but it is to the hidden supplies that contractors should give careful attention.

The good work of the Copper and Brass Association is a big help to contractors in educating the public to the merits of brass pipe throughout the house. This is a definite example of selling the public the best equipment on the basis that it is the cheapest in the end.

In offering plumbing contracts, builders should select with care progressive plumbers, men who by the character of their work, the appearance of their shops and their standing in the community, indicate that they have the necessary ability to install your plumbing on such a basis that it will be a credit to your new building.

Many of the modern contracting plumbers have displays of plumbing merchandise and the builder may see the complete plumbing layout before deciding. In some communities it is necessary to do business through the plumbing jobber, because he has the only display. But we close our articles with the admonition—be sure that the plumbing contractor is a responsible one. And when you do this, you'll find that even if it costs a trifle more, it is cheaper in the end.



The Right Kind of Fixtures for the Bathroom Mean Comfort for the Home, but These Fixtures Should Be Backed Up by Quality in the Hidden Plumbing Which Supplements Them or It Will Be a Source of Future Trouble and Expense.

# NEWS of the FIELD



## Architectural Competition Announced

**A**N architectural competition, with cash prizes amounting to \$3,200, has been inaugurated by the United States Gypsum Company, to be conducted under the auspices of the American Institute of Architects.

This competition is for the four best house designs in each of two classes, for houses to be built of Structolite fireproof construction. One set of prizes is for the winning five-room bungalow designs; the other for the winning six-room, two-story dwelling designs.

There are two first prizes of \$500 each, two second prizes of \$300 each, two third prizes of \$200 each, two fourth prizes of \$100 each and twenty prizes of \$50 each for honorable mention. The purpose of the competition is to acquaint architects with the merits of Structolite as a fireproof building material in the construction of small as well as large buildings. The competition closes April 15.

Full details may be secured by writing the United States Gypsum Company, Fireproofing Division, 205 West Monroe Street, Chicago.

## Formally Open New Plant

**A** FORMAL opening of the new plant of the American Flor Surfacing Machine Company, 508-542 S. St. Clair Street, Toledo, Ohio, was held on Saturday, February 21, from one to four in the afternoon. Invitations were issued and many people showed their interest by attending the opening and inspecting the company's new equipment.

## National Plans New Plant

**P**LANS have just been completed for an addition to the plant of the National Manufacturing Company, Sterling, Ill., to take care of the rapidly increasing demand for National hardware. This addition will be a five-story reinforced concrete building, 110 by 120 feet, adjoining the main factory and will be faced with brick to conform with the rest of the plant. It will be used both for manufacturing and warehouse purposes and will permit about 50 per cent increase in working equipment.

The new structure will be a model of industrial construction. The floors will be of concrete slabs and the stairs will be of iron or iron and concrete. Every precaution will be taken to make a complete fireproof building, including a sprinkling system. Windows will extend the full length of each story,

making it a daylight factory. Work will be begun as soon as the ground is clear and the weather permits, probably about the first of April.



### General Fireproofing Convention

**T**HE Ninth Annual Convention of The General Fireproofing Company was held February 12, 13 and 14, and was attended by dealers and salesmen from all parts of the United States. New products and methods of building construction were discussed during the three day session and the visitors were entertained each evening by special programs.

Mr. Foster, president of the company, was unable to be present, and the convention was formally opened by Mr. S. S. French, vice-president and general manager.

Mr. French spoke on "Our Facilities," in which he included not only machinery in the plant, but also ideas, plans and co-operation of the entire organization.

Speaking of prices, he predicted a general downward trend for the next five years. This country, he stated, is in a prosperous condition, growing rapidly, expanding in a business way and increasing in population. Many new homes are being built and there should be no let-up in building operations. He could see no depression for the next five years, despite the present high wages.

Other speakers were, W. B. Turner, sales manager; Commissioner Wharton Clay; R. S. Gildart, advertising manager; O. W. Chaffee, credit manager; F. M. Russell, traffic manager; H. I. Glazier, assistant sales manager; John Travers, manager of the waterproofing service department; D. M. Strickland, manager of the American Rolling Mill Co.; Charles Johnston, district manager; J. P. Stalker, manager of the engineering and service department.

### New Awning Patterns

**T**HE demand for awnings today calls for something "different" and out of the ordinary and manufacturers are producing new patterns to meet this demand. The 1925 sample book, just issued by John Boyle & Co., Inc., of New York and St. Louis, shows many brilliant effects in both woven and painted fabrics, which will undoubtedly interest the householder. For instance, canary yellow is very effectively interwoven with green and white, and another unusual effect is made up of coffee brown interwoven with white and embellished with fine, brilliant red lines.



### W. M. Simpson Lumber Co. Moves Office

**O**N February 14, 1925, the W. M. Simpson Lumber Company moved its general offices for its sixteen yards, and also the wholesale office, from Indianapolis, Ind., to Paris, Ill.



### Van Guilder System Changes Hands

**A**N entirely new organization has taken over the business of the Van Guilder System Concrete Building, Inc., which was formerly located at Rochester, N. Y. The new management, operating under the same name and under the direction of George Burford Hopper as president, has established itself at 15 East 40th Street, New York City.

The Van Guilder System is a method of constructing double monolithic concrete walls by the use of machines which make unnecessary the customary wood or metal forms. As an officer of Isaac A. Hopper Sons, Mr. Hopper used the Van Guilder System on a number of construction jobs for his company and was so favorably impressed by it that he interested several of his friends, with the result that they finally organized to take over the business.



Salesmen and Dealers of the General Fireproofing Company Who Attended the Ninth Annual Convention February 12, 13, and 14, Came from All Parts of the Country to Discuss New Products and Methods of Building Construction.



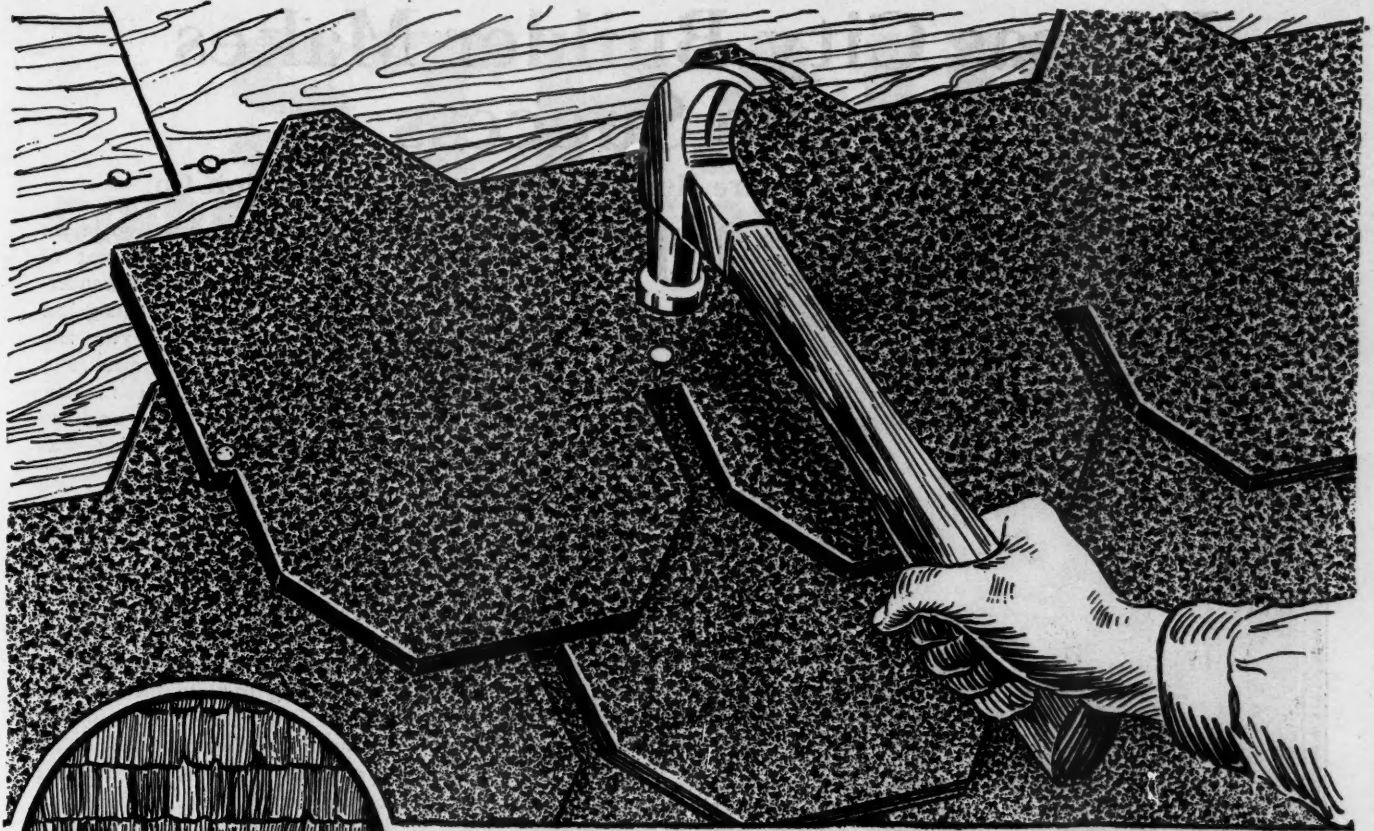

*Easily Laid Over  
Old Wood Shingles*



*There is but  
one Rubroid*      *Look for the Man  
on the Label*

**The RUBEROID Co., Dept. 1  
95 Madison Ave., New York, N. Y.**

Gentlemen:

Please send me dealer's name and samples of Ruberoid Octab Strip-shingles.

Name.....

Address.....

.....

.....

*Indicate whether home owner, builder, carpenter or contractor.*

## A Profit-Making Shingle

**T**HE quicker you can do a job, so long as it's done well, the more profit in it for you. This is one of the prime reasons why thousands of builders have used hundreds of thousands of squares of Ruberoid Octabs during the past few years.

Whether laid on a new roof or over old wood shingles, *Ruberoid Strip-shingles are labor savers.* They reduce your costs for handling, lining up and nailing.

Due to their patented form, Ruberoid Octabs afford 50% greater headlap protection than the usual 10 inch strip-

shingle. You can recommend them without fear to the most critical customers.

You probably know the Ruberoid distributor in your town. If you don't, ask us his name. It will pay you to talk to him before you do your next roofing job. The coupon is for your convenience.

**The RUBEROID Co.**

Chicago

New York

Boston

# RUBEROID

## OCTAB STRIP-SHINGLE



# Kansas City Builder Makes Unique Success

Obstacles Prove Boost to Live-wire Head of the Fogel Construction Co.

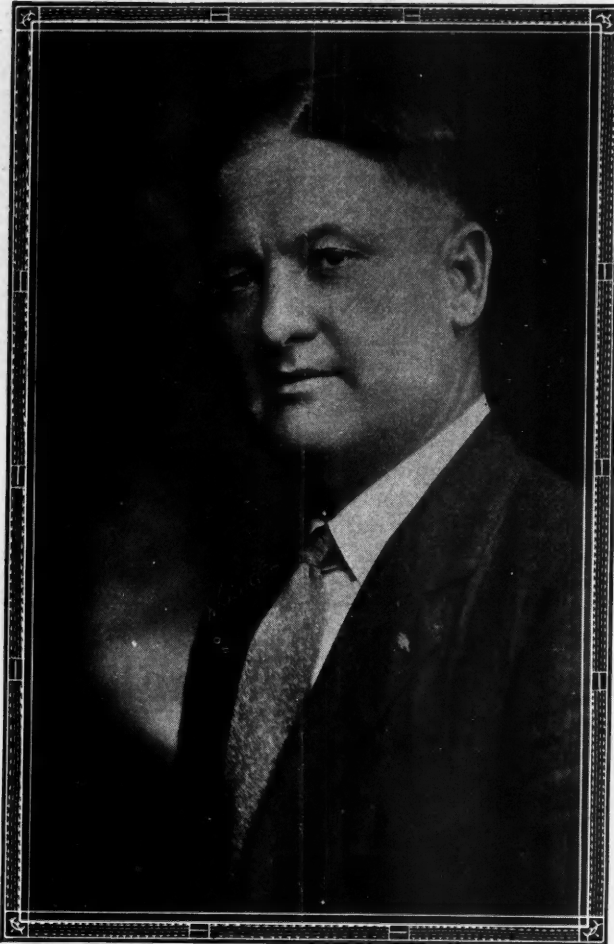

Paul M. Fogel, Head of the Fogel Construction Company, of Kansas City, Is Still a Young Man with a Future as Well as a Past Success.

**P**AUL M. FOGEL was born forty-two years ago in the little Nebraska town of Nelson, the county seat of Nuckolls County. When fourteen years old the wanderlust struck him and he headed south. His funds running low he got a job on a farm and stuck with it for a year and a half and then decided he would be a railroad man. For five years or thereabouts he served as brakeman, fireman, and in construction work on the railroad and then came to Kansas City where his parents were living. This was July, 1901.

The young railroader's first job in Kansas City was an apprentice carpenter at thirty cents an hour. He showed aptitude with the hammer and plane and soon was a full-fledged carpenter with his union card in his overalls pocket. Six years at the carpenter trade and Paul Fogel made a decision. He told his father, who was then with the Kansas City Elevator Company, that either he was going to get into business for himself or he was going back to the railroad. And it was then that the firm of Fogel & Son was formed for the purpose of doing a general building business.

The business grew and prospered and late in 1916 the Fogel Construction Company was incorporated with M. L. Fogel, president; Paul M. Fogel, vice-president and manager, and Lyle Fogel, secretary-treasurer. Fogel & Son and the Fogel Construction Company have been active in business in building operations in Kansas City. Some of their larger contracts have been the Kansas City Terminal, exclusive of the Union Station itself; the Gate City Bank Building; Wesley Hospital; Gateway Station; the Campbell Baking Company plant; the Westport Junior High School, which is under construction at this time.

Several of the important Fogel jobs of late have made large use of cinder concrete blocks. "In keeping the costs in the use of cinder blocks on our different jobs," Mr. Fogel writes, "we have found that we can save about 10 per cent for plastering on cinder block. There is also a saving of at least 50 per cent on labor in placing grounds on cinder block partitions. Comparing the cost of building a 12-inch cinder block wall with a 12-inch brick wall, will say if common brick were \$5.00 per thousand delivered on the job; we could build the wall 8 by 12 by 16-inch block as cheaply."

But to go back a little. One might think and naturally that a technical education would be necessary for the sort of work that Paul Fogel has been doing. It would be for most men but all the "book-learning" Mr. Fogel received was in the grade school and three months in the high school at Superior, Neb. His education, however, did not stop there. He has educated himself by study and hard work and it is doubtful if there are many better posted men in Kansas City along a variety of lines than is this young man who left the little Nebraska town at the age of fourteen years to make a living.

He has educated himself by study and hard work and it is doubtful if there are many better posted men in Kansas City along a variety of lines than is this young man who left the little Nebraska town at the age of fourteen years to make a living.



Felix Theatre, Kansas City. Fogel Construction Co., Builders. Harry Drake, Architect.

# STRAUB

## CINDER CONCRETE BUILDING BLOCKS

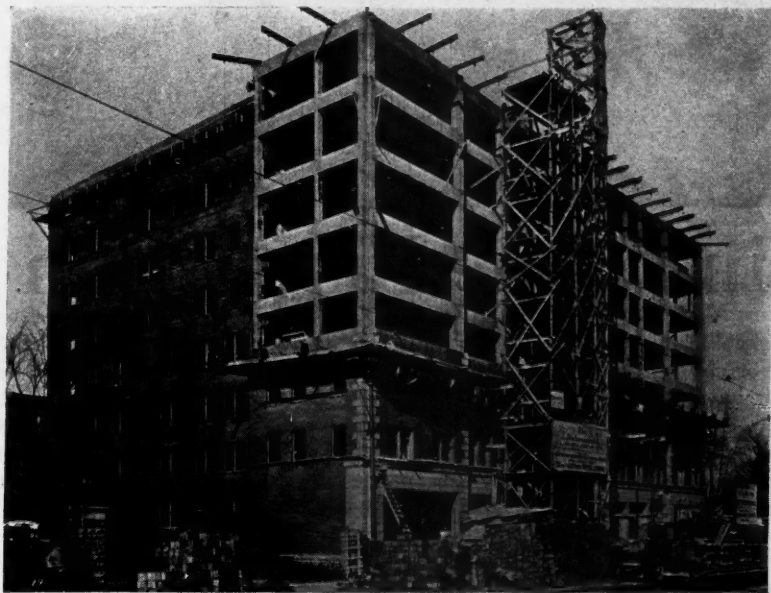

Ambassador Hotel, Kansas City. Quality Builders, Owners and Builders. The cinder concrete blocks for this building were furnished by the Straub Cinder Block Co., Kansas City, Mo.

One standard block displaces twelve bricks and requires less than one-third the mortar. They are *absolutely damp-proof*, fire-proof and soundproof; qualities thoroughly attested in more than ten thousand buildings of every description.

On account of their numerous unique properties, resulting in superior walls at reduced costs, Architects, Contractors and Builders say *Straub Cinder Blocks* have revolutionized the building material industry.

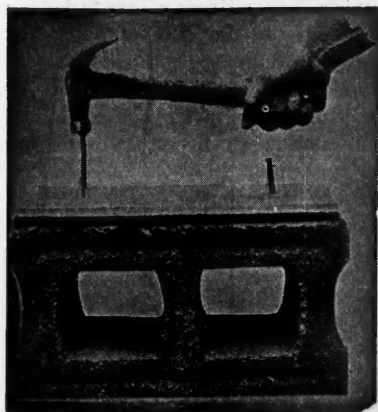

As good as wood for nailing, and the nails hold.

*Responsible parties will be licensed to manufacture and sell in open territory.*

**CROZIER-STRAUB, Inc.**  
120 W. 42nd Street New York, N. Y.

For Churches, Hotels, Theatres, Hospitals, Apartment Houses, Residences, Garages, Barns, Ice Houses, Dry Kilns, Factories, Warehouses, Office Buildings, etc. Ideal for Bearing, Foundation and Partition Walls.

For exterior work, which is to receive stucco and for interior walls and partitions, to which the plaster may safely be attached direct without furring and lath, and because of its nailability, there is no material on the market which can equal it.

The blocks are uniformly made, are light weight and lay quickly.

Tested and passed with high official rating by National Board of Fire Underwriters' Laboratories.

### We Have 50 Plants

in successful operation. We invite Architects, Contractors and Builders to visit and inspect our plants. Write for address of plant nearest you. Ask for our complete circular matter, test reports, etc. Your inquiry will be given prompt attention.

### Ten Reasons Why

- 1—Damp-proof, moisture-proof and frost defying.
- 2—Sound proof.
- 3—Tenacious with great strength.
- 4—Non-conductor of heat, cold and electricity.
- 5—Perfect key for inside plaster and outside stucco. (No wood or metal lath required inside or out.)
- 6—Fire-resisting.
- 7—As good as wood for nailing. Nails can be driven into it with ordinary hammer as easily as into wood and the nails hold.
- 8—Rot and vermin-proof.
- 9—Does not sweat—therefore requires no furring or lathing. No mold.
- 10—Great Saving in Cost.



# MOTOR TRUCKS and TRAILERS



## Truck Cleaning and Inspection

**T**HE following are important points which should be attended to in going over the motor truck for cleaning and inspection, and which are too frequently overlooked:

The drip pan under the motor should not be allowed to accumulate dirt, grease and oil, since it may be the cause of a serious fire or accident. The pan should be removed from time to time and scrubbed with kerosene. A stiff brush should be kept on hand for this purpose.

The motor itself should be kept clean. An effective method of washing down the dirt and oil is to spray kerosene over the outside of the engine, or to apply a mixture of half kerosene and gasoline freely with a brush. In using a brush for this purpose, be careful not to let the metal part of the brush come in contact with electric terminals, since this may cause a short circuit and the consequent risk of fire. While cleaning the motor, it is a good plan to go over all outside nuts and to tighten them. Be sure that all nuts are securely held in place with a cotter pin or lock washer.

Oil leaks in various parts of the truck must be carefully watched and remedied. Detecting these leaks on the street or on the garage floor is usually impossible, but if the operator will occasionally place a large piece of wrapping paper under the car while it is standing in the garage, he will have little difficulty in locating the source of the trouble.

On practically all trucks, the oil and gasoline lines are equipped with strainers to insure that dirt and grit will not pass through. These strainers should be removed and carefully cleaned at regular intervals of about a thousand

miles. The strainers can be located by referring to the truck instruction book. When removed, they should be permitted to dry and then the dirt should be blown out. Do not remove dirt by picking the screen with pins, as this will ruin the strainer.

Many truck operators neglect the underside of their car and this is very largely the reason why so many nuts, bolts, lock-washers and other small parts of cars are soon scattered on the highways. It is true that road strains, vibration, etc., tend to loosen many parts underneath the truck and to cause considerable damage unless measures are adopted to avoid this. The operator should know at all times, the condition of his truck underneath the body, and should go over the nuts and bolts at intervals, tightening them and making sure that they are securely fastened with cotter-pins and lock-nuts.



### How to Manipulate Truck at Curb

**T**HE proper way to park a truck in a narrow space at the curb is to turn into the space driving forward, then out to get the truck at an angle to the curb and back in, turning the wheels as a bit of practice will show best. In manipulating the truck, the front wheels should never be turned by moving the steering wheel when the vehicle is not in motion. This puts undue strain on the steering apparatus and will cause too much play in the steering gear. If it becomes necessary to turn the front wheels of a truck while it is standing still, they should be moved by forcing not only the steering wheel, but also by pulling the front wheels around.

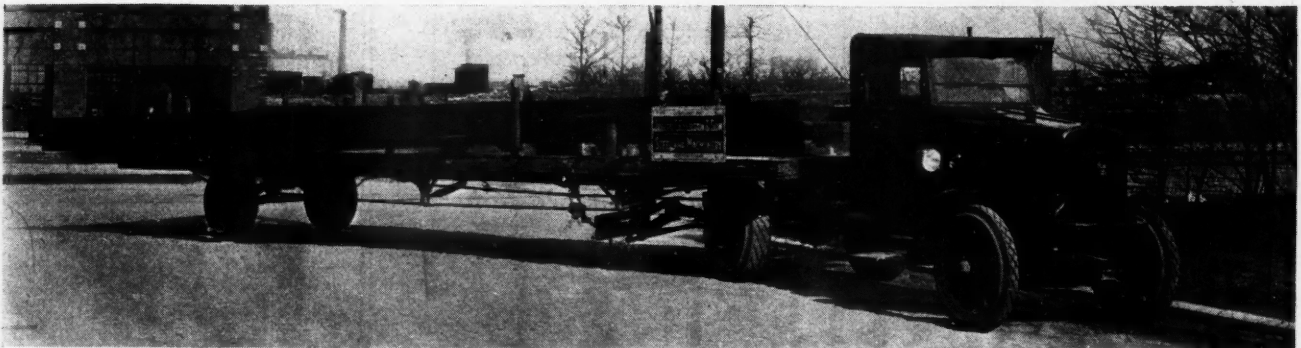

A Heavy Truck with Semi-Trailer Will Handle the Largest and Heaviest of Structural Steel with an Ease That Would Be Impossible with Any Other Means of Transportation and When Not Needed for This Purpose a Different Type of Trailer May Be Used with the Truck for Other Types of Hauling.



**International Motor Trucks are sold and serviced through the largest company-owned truck service organization in the world. Direct company branches are located in 105 cities as follows:**

- Aberdeen, S. D.
- Akron, Ohio
- Albany, N. Y.
- Amarillo, Tex.
- Atlanta, Ga.
- Auburn, N. Y.
- Aurora, Ill.
- Baltimore, Md.
- Billings, Mont.
- Birmingham, Ala.
- Bismarck, N. D.
- Boston, Mass.
- Buffalo, N. Y.
- Cedar Falls, Iowa
- Cedar Rapids, Iowa
- Charlotte, N. C.
- Chattanooga, Tenn.
- Cheyenne, Wyo.
- Chicago, Ill. (3)
- Cincinnati, Ohio
- Cleveland, Ohio
- Columbia, S. C.
- Columbus, Ohio
- Council Bluffs, Iowa
- Dallas, Tex.
- Davenport, Iowa
- Dayton, Ohio
- Denver, Colo.
- Des Moines, Iowa
- Detroit, Mich.
- Dubuque, Iowa
- Duluth, Minn.
- East St. Louis, Ill.
- Eau Claire, Wis.
- Elmira, N. Y.
- El Paso, Tex.
- Evansville, Ind.
- Fargo, N. D.
- Fort Dodge, Iowa
- Fort Wayne, Ind.
- Fort Worth, Tex.
- Grand Forks, N. D.
- Grand Rapids, Mich.
- Green Bay, Wis.
- Harrisburg, Pa.
- Helena, Mont.
- Houston, Tex.
- Hutchinson, Kan.
- Indianapolis, Ind.
- Jackson, Mich.
- Jacksonville, Fla.
- Kankakee, Ill.
- Kansas City, Mo.
- Knoxville, Tenn.
- Lincoln, Neb.
- Little Rock, Ark.
- Los Angeles, Calif.
- Louisville, Ky.
- Madison, Wis.
- Mankato, Minn.
- Mason City, Iowa
- Memphis, Tenn.
- Milwaukee, Wis.
- Minneapolis, Minn.
- Minot, N. D.
- Nashville, Tenn.
- Newark, N. J.
- New Orleans, La.
- New York, N. Y.
- Ogdensburg, N. Y.
- Oklahoma City, Okla.
- Omaha, Neb.
- Parkersburg, W. Va.
- Parsons, Kan.
- Peoria, Ill.
- Philadelphia, Pa.
- Pittsburgh, Pa.
- Portland, Ore.
- Quincy, Ill.
- Richmond, Ind.
- Richmond, Va.
- Rochester, N. Y.
- Rockford, Ill.
- Saginaw, Mich.
- St. Cloud, Minn.
- St. Joseph, Mo.
- St. Louis, Mo.
- Salina, Kan.
- Salt Lake City, Utah
- San Antonio, Tex.
- San Francisco, Calif.
- Sioux City, Iowa
- Sioux Falls, S. D.
- South Bend, Ind.
- Spokane, Wash.
- Springfield, Ill.
- Springfield, Mo.
- Terre Haute, Ind.
- Toledo, Ohio
- Topeka, Kan.
- Watertown, S. D.
- Wichita, Kan.
- Winona, Minn.

*Three great factories are devoted exclusively to the manufacture of International Trucks. A corps of factory-trained Road-Engineers inspect regularly and without charge all Internationals in service.*

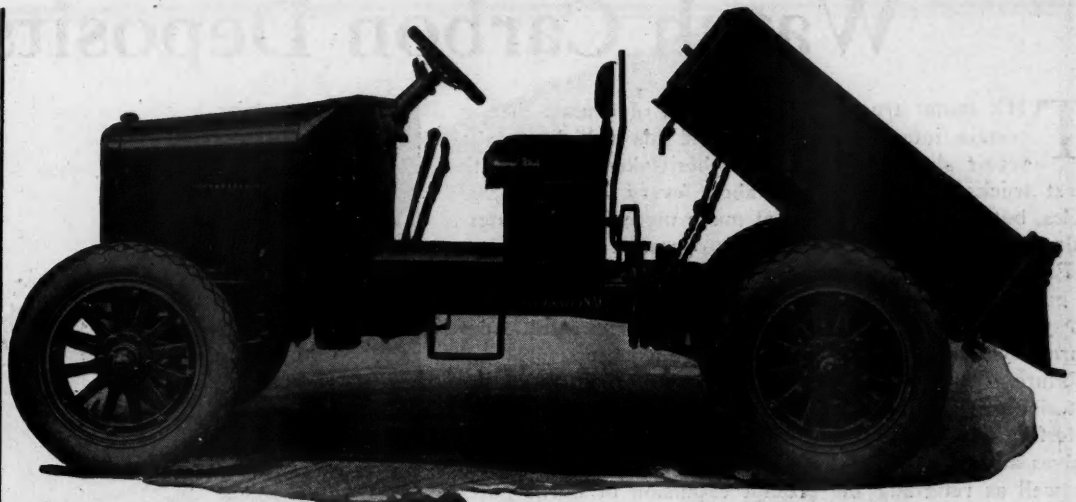

*The new Model SD, carrying a 1-yd. body, appeals to large and small contractors in all lines. It is unusually convenient, genuinely economical to operate and is built to last.*

# Plain Every-Day Hauling

The job of a motor truck is to haul loads in all seasons and to go on doing it for years. After you have invested in trucks, the less you hear about them—except good words from your accounting department, your customers, and your drivers—the better. You want consistent low-cost hauling.

Motor trucks lead hard lives. It is not easy to build trucks that stand the gaff, but they are easy to find—in Internationals. Thousands of firms whose hauling needs are as insistent as yours are proving it to their complete satisfaction.

International Motor Trucks are the products of twenty years automotive experience. You will find the result of that long experience in the sound principles of design and in every mechanical detail of International Trucks. And there are other factors in what International offers you; go outside of the truck itself and give a thought to the matchless service outlined in the column at the left. Is assurance of dependable service, near at your hand, also a part of what you ask of a truck?

International Heavy-Duty Trucks are built in 3,000, 4,000, 6,000, 9,000 and 10,000-pound maximum capacities with bodies to meet every requirement. There is also a sturdy Speed Truck for loads up to 2,000 pounds. Upon request we will gladly supply you with names of International owners in your own line of business and the address of the nearest showroom where the full line of new models is on display.

**INTERNATIONAL HARVESTER COMPANY**  
 606 So. Michigan Ave. of America Chicago, Ill.  
(Incorporated)

# INTERNATIONAL HARVESTER TRUCKS COMPANY

**FOR LOW-COST HAULING**

# Watch Carbon Deposits

**T**HE motor truck operator knows, of course, that at certain intervals he must send his vehicle to the repair shop to have "the carbon taken out." With most trucks this is necessary about every 2,000 or 3,000 miles, but it may be required at much more frequent intervals, depending on how the truck is operated.

Excessive carbon deposits in the combustion chamber of a gasoline engine very often cause loss of power and noisy operation of the motor. These deposits result from burnt cylinder oil and sometimes from excessively rich mixture. They accumulate on the piston top and in the interior of the combustion head and valve chamber. They interfere with correct valve operation by gumming up the valves and prevent a full charge from reaching the motor, as well as retarding the prompt expulsion of burnt gases by building up around the valves.

The deposits in the cylinder head may cause trouble, owing to some projecting particle remaining incandescent from the heat of a previous explosion and firing the fresh charge prematurely. Carbon deposits always produce loss of power, but their presence is usually clearly indicated by a pronounced knocking or pounding noise. The only remedy for this defective condition is to remove them from the engine interior. This is done by scraping away the material with small hoe-form steel scrapers that may be inserted through the holes left when the valve chamber caps are removed, or by removing the cylinder head if the construction permits. This accumulation may be prevented by careful supervision of the amount of oil supplied the motor, making sure that it is never in excess of the actual requirements, using only the best grades of cylinder oil and by careful regulation of the fuel mixtures. These deposits may be reduced to some extent by injecting three or four tablespoonfuls of kerosene into the cylinders at the end of a day's run, through the priming cocks. This softens the deposit which has accumulated during the day, and when the engine is started up the next morning the dissolved carbon will be ejected through the exhaust, as it will be carried out by the burnt gases. The soft deposit is not difficult to cope with and, in fact, various chemical carbon removers are advertised quite extensively which will remove it without making it necessary to take the motor apart, and it may be burned out with the aid of oxygen, provided the accumulations are not of too long standing.

## Tack This in Your Garage

### SAFETY LAST

**L**IES slumbering here one William Lake; he heard the bell, but had no brake.

At fifty miles drove Ollie Pidd; he thought he would not skid, but did.

At ninety miles drove Eddie Shawn; the motor stopped but "Ed" kept on.

Here he sleeps, one Johnnie Fonker; he rounded a turn without a honker.

Down in the creek sleeps Jerry Bass; the bridge was narrow, he tried to pass.

Beneath this stone sleeps William Raines; ice on the hill—he had no chains.

Here lies the body of William Jay, who died maintaining his right of way.

Here rests the remains of Percival Sapp; he drove his machine with a girl in his lap.

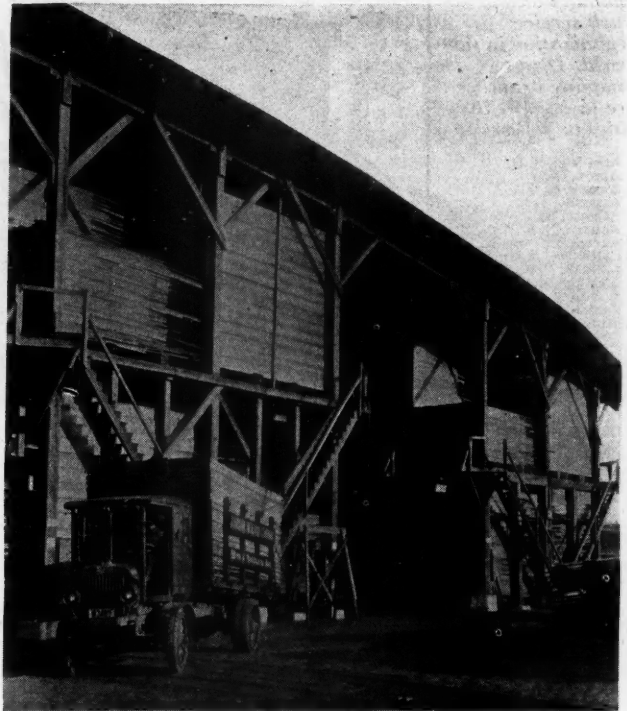

Again the Truck Enables Quick Delivery of Lumber to the Construction Job and with Demountable Bodies There Need Be no Delay for Loading and Unloading on the Larger Jobs.

The hard, thoroughly baked on carbon can only be removed positively by mechanical means.



## Adjusting the Carburetor

**M**ANY truck operators are familiar with the construction and arrangement of the carburetor, yet find it necessary to enlist the services of a repair shop when adjustments are required. This is generally because they are not familiar with the symptoms which indicate the necessity for adjustment, and how these may be properly taken care of. Here are a few brief points to assist in a correct understanding of the carburetor.

When the carburetor is flooding, giving too much gasoline, either (1) the float is too high; (2) the float is soaked with gasoline; (3) the seating of the inlet needle valve is imperfect, or (4) there is dirt in the inlet needle valve.

If there is not enough gasoline passing through, either (1) the float is too low; (2) there is a sediment or obstruction of some kind between the needle valve and seat, or (3) there is a sediment, water, or some obstruction in the bowl, feed pipe or in the connections.

Backfiring or sudden stopping is generally the result of a mixture that is too lean. Unless this is caused by one of the items mentioned in the preceding paragraph, the chances are that the needle valve is too far closed. Air leaks around the throttle stem, at carburetor flange, or around the gaskets between the inlet manifold and cylinder block may also be responsible for this.

When the mixture is too rich, the needle valve is too far open. Sometimes this is caused by the choker valve being shut or by any of the items mentioned above under "flooding." A leaky carburetor may usually be traced to a puncture in the bowl, to an imperfect gasket or to a loose feed pipe connection.

"Made by Lupton"  
means it's right

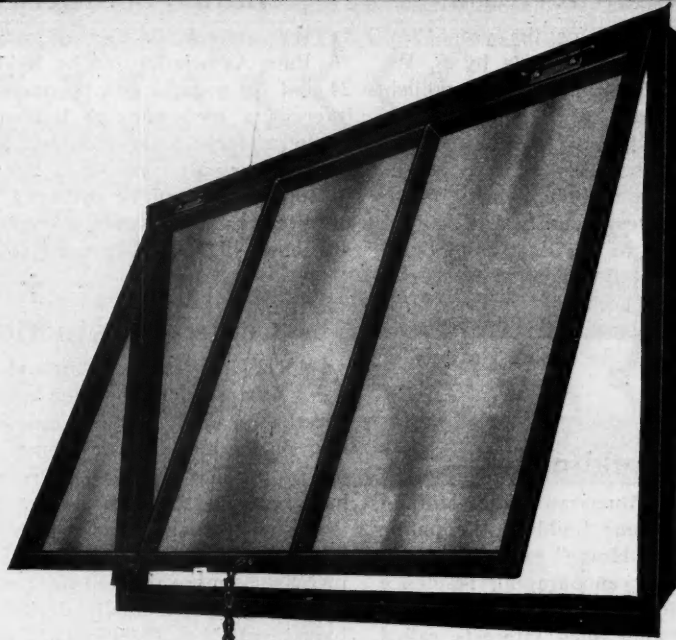

Made in Three Sizes



## A New and Improved Basement Window of Copper-Steel

**T**HIS window pleases everybody—and no wonder! Lupton investigated thoroughly the needs of builders and home owners, applied their long experience in window making, and built this to suit the need for a practical steel basement window. It embodies all the advantages of previous types of basement windows, but it is lighter, more rigid, and more weather-tight than any other.

### You'll Like This Lupton Window

The reduced weight of this new Lupton Basement Window and the fact that it comes completely assembled with all hardware attached, makes it appeal strongly to practical builders. They appreciate the durable copper-steel construction, the stout welding which prevents distortion, and the oven-dried paint of the Lupton Windows, because these features make a window that stands rough handling and one that produces a permanent and economical job in the wall.

### High Spots in Its Value

1. **COPPER-STEEL**—Solid casement sections of copper-steel are used for both window frame and sash.
2. **STOUT WELDING**—New method of welded assembly gives great rigidity and prevents distortion.
3. **LOOSE PIN HINGES**—Hinge butts are solidly riveted, but sash is easily removed by taking out the split hinge pins.
4. **WEATHER-TIGHT**—The continuous anchor builds into the masonry and gives a solid weather-tight job.
5. **GUIDE ANGLE**—This angle gives a definite line for the mason to work to, and insures a free opening sash.
6. **SELF-CENTERING LOCK**—Sash is centered automatically when closing, and locked tight with a wedge pin.
7. **SOLID STEEL DRIP**—An extra degree of weather-tightness is gained by the drip on the bottom sash member.

## DAVID LUPTON'S SONS COMPANY

Founded 1871  
PHILADELPHIA

Atlanta  
Baltimore  
Boston  
Buffalo  
Chicago  
Cleveland



Dallas  
Detroit  
Newark  
New York  
Pittsburgh

701



### Building Permits Show Increase

OFFICIAL building permit figures for the year 1924, according to a survey of 343 cities, made by S. W. Straus & Co., show a total of \$3,630,258,649 and establish the accuracy of the previous estimate of \$5,750,000,000 for the entire country. The gain over 1923, in the cities reporting, was four per cent, which may be taken as fairly representing the percentage of gain for the whole country.

Since 1923 the location of greatest activity has shifted from the Central and Pacific West to the East and South. In the 25 cities reporting the greatest volume, the percentage of increase varied from seven per cent in New York City to 35 per cent increase for Rochester, N. Y. The South showed a gain of 15 per cent, the greatest of any of the four regional divisions.



### Will Discuss Building

HOW to raise the standard of American homes built in the future, what facts on home building the public should have, and how "Own Your Home" expositions can best be developed as mediums for encouraging residence construction, are among the subjects to be taken up by a convention of the construction and allied interests called by the National Association of Real Estate Boards in connection with the "Own Your Home" Fifth Annual Chicago Exposition to be held at the Coliseum in March.

Officials of more than forty allied trade organizations and associations that a year ago approved the plan of licensing all such expositions and building shows by the National Association of Real Estate Boards have been invited to attend this convention, the first of its kind ever held.



### Mac-Stone Occupies New Plant

THE Mac-Stone Stucco Company, Inc., organized for the purpose of manufacturing Mac-Stone and Oxyment products, has occupied a newly built plant and offices at 1552-1562 Troy Avenue, Brooklyn, N. Y. George V. MacPherson is president of the company and W. S. Steele is sales manager and a member of the firm. Both are well known in the building industry.



### Open New York Office

THE Electric Rotary Machine Co., 3825-3831 W. Lake St., Chicago, Ill., manufacturers of floor surfacing and refinishing machines have just announced the opening of an eastern sales office, located at Suite 1843, Grand Central Terminal Building, New York City.

The rapid growth of business has made it necessary to locate in New York City, so that the eastern trade may have the opportunity of dealing direct with a resident representative. A complete line of equipment will be on exhibition and available for demonstrating purposes. Mr. H. L. Lorsch, will be the resident representative.



### Administration Building for Employees

THE Kirsch Manufacturing Company, Sturgis, Mich., boast a new institution of which it is justly proud. This is an administration building for the employes which contains a spacious lounging room, ball room, recreation room, dining room and swimming pool.

The building is lavishly furnished and beautifully decorated throughout and the floors are all laid with Asbestone flooring of a shade to harmonize with the general color scheme of the decorations, and quality offering resiliency and durability. The architect is Mr. Ernest S. Batterson, of Kalamazoo, Mich.

### Annual Southern Pine Meeting

THE annual meeting of subscribers to the Southern Pine Association, to be held in New Orleans, March 24 and 25, promises to be one of the most important and interesting gatherings of lumber manufacturers ever held in the history of the industry, according to announcement by Secretary-Manager H. C. Berckes. The general meeting of subscribers will be preceded by meetings of the board of directors and standing committees on March 23. All sessions will be held in the Roosevelt Hotel, New Orleans.



### Cement Production Sets Record

A REVIEW of the Portland cement industry, based on data compiled by the United States Geological Survey and the Bureau of Labor Statistics, shows that the industry has, during the past year, met an unprecedented demand for its product while prices received by the manufacturers have remained at relatively low levels.

During the past four years shipments have increased from 96,000,000 barrels in 1920 to 145,747,000 barrels in 1924, an increase of more than 50 per cent. During the same period the prices have actually declined from a peak of \$2.02 a barrel in 1920 to \$1.90 in 1923, with the probability that the average for 1924 will be less than that for 1923.

Shipments for 1923 exceeded all previous records by a substantial amount, but 1924 shows a further increase of 7.2 per cent, establishing a still higher record.



### Bonus a Business Investment

AS its eighth annual Christmas bonus, the S. C. Johnson Company, Racine, Wis., distributed \$78,767 among its employes. In all 348 persons participated, including office employes, factory workers and salesmen. Those who had been with the firm for one year received 5 per cent of the amount of their yearly salary and this percentage ranged up to 30 per cent for those with 10 years or more of service.

With each bonus check went a letter from Herbert F. Johnson, senior partner and general manager of the company, expressing his appreciation of the share which each had in making the year's business a success. Mr. Johnson considers this bonus a profitable business move.

"The sales of the company," he says, "have increased 400 per cent since the bonus was inaugurated and the 1924 sales show a larger percentage of profit than any previous year in the history of the business."



### Mill Construction Booklet

CHAPTER six of the National Lumber Manufacturers' Association's Fire Prevention Series, a cumulative work on "Lumber and Its Utilization," has just been issued. This is a booklet prepared in response to a demand for complete and authoritative information on mill construction for factories and warehouses. It is entitled "Fire-Safe Industrial Buildings" and will be followed by another on "Details of Heavy Timber Construction."

The association announces that a copy will be sent free on application to manufacturing companies, interested professional men, and industrial executives. It is in no sense an advertising publication but purely technical and educational in character.

It treats of heavy timber construction as "a new type which has only recently reached its present high state of development" and is therefore not thoroughly known to those trying to select the particular type of construction best suited to their needs.



**Truscon 1-A Hy-Rib Metal Lath is easily and quickly applied. Weather does not affect it and it is insurance against fire, the most dangerous enemy to buildings.**

## Crackless Walls and Ceilings At an Economical Cost

Truscon 1-A Hy-Rib Metal Lath is an important item in the modern, fireproof construction of homes and other buildings. The use of Truscon Metal Lath results in rigid walls and ceilings that will not crack. It does not warp or shrink and will not discolor plaster. Truscon Expanded Metal Corner Bead aids in securing a wall of permanence. Corner Bead protects plaster at the points in corners and edges where it is most likely to be damaged. Construction of walls and ceilings with these products is economical in cost and maintenance and lends fire safety.

*Write for further information*

**TRUSCON STEEL CO., YOUNGSTOWN, OHIO**

*Warehouses and Sales Offices in Principal Cities  
Canada: Walkerville, Ont. Foreign Div.: New York*

# TRUSCON

1-A HY-RIB  
METAL LATH



**Truscon Expanded Corner Bead on metal, wood lath or masonry**

WHEN WRITING ADVERTISERS PLEASE MENTION THE AMERICAN BUILDER

# ELECTRIFY ALL BUILDINGS

A Department of Up-to-date Information  
for all who Plan and Build

## Lower Ceiling Heights Result in New Type of Chandelier

**I**N the days when homes were lighted by gas it was necessary to keep the open gas flame of the chandeliers at a safe distance from the ceiling. Chandeliers were, therefore, built 36 to 40 inches in length. When installed so as to give a clearance of 6½ feet above the floor it was found that the ceiling height of the room must be 9½ to 10 feet. This is the ceiling height that you will find in old residences.

The introduction of electric lights created a new condition. It was no longer necessary to keep the lights several feet away from the ceiling. But it was not until the World War, when the high cost of labor and material forced economies in building construction, that architects generally began to design houses with low ceiling rooms. Today it is quite common to find rooms with ceilings not more than 8¼ or 8½ feet from the floor.

To meet this new condition designers originated a number of attractive, close-up-to-the-ceiling types of chandeliers. These have been favorably received

by architects and by the public and dealers should see that their show rooms contain samples of these ceiling type fixtures since many houses are now being built with ceilings too low for the old type of pendant fixture.

Prior to the development of these ceiling type chandeliers, architects in planning the lighting of a low ceiling room, omitted the central ceiling light

altogether and relied on brackets and portables for illumination. But most people like to have a ceiling fixture for general illumination, using the brackets and portables for auxiliary lights.

One of the first questions the dealer should ask a customer for lighting equipment is: "How are your ceilings?" If the answer is 9½ or 10 feet a pendant type chandelier may be recommended, but if the ceiling height is not much over 8 feet a fixture that fits close to the ceiling will usually be more suitable.

Make the suggestion to your customer anyway and tell him the reason why close-up-to-the-ceiling fixtures are coming into fashion. We have given you the reason in this article—the long pendant fixture dates back to the days of open gas flames when ceilings had to be higher than is now necessary.

You might add that in a room with a low ceiling there is a distinct advantage in placing the lights close to this position they will be removed from the line of vision and the light will be more generally diffused than would be the case if the light were nearer the floor.

In addition to this, from an artistic standpoint, the close-to-the-ceiling type of fixture is more appropriate than the long pendant type, in a room with a low ceiling.

"Reason why" talk is always interesting to the customer and convinces him of your ability to give him intelligent co-operation in selecting fixtures for his home.

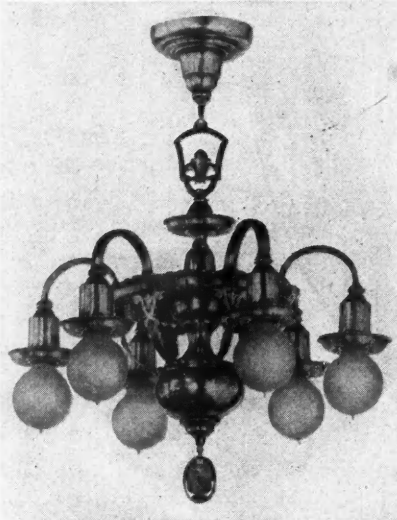

A Compromise Between the Pendant Type of Chandelier and the Ceiling Type Fixture Is It Can Be Used in the Low Ceiling Room.



A Fixture Which Is Typical of the Modern Tendency to Place the Lights Close to the Low Ceiling.

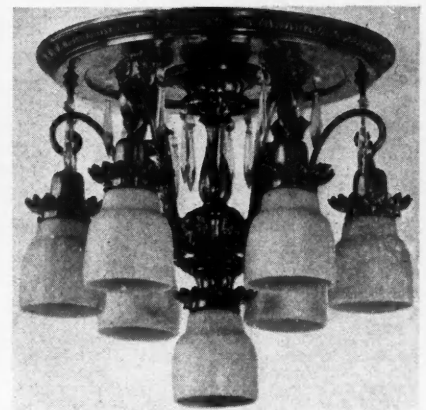

A Graceful Shower Effect Is Well Designed to Meet the Requirements of the Room with a Low Ceiling.





*It will last as long as the house—*

When you specify a G-E Wiring System, you know from your experience with General Electric products that it will give lifetime service. And the public knows it, too.

There is no longer any need to scrape one-tenth of one per cent from the cost of a house by saving on the wiring materials. The public understands better, now, the ultimate economy of quality wiring. Now you will find a readier acceptance of a *quality* bid at a fair price. And you will find that houses equipped with a G-E Wiring System for safety and permanence will sell faster—bring you quicker profits.

A series of two-color advertisements in the Saturday Evening Post is keeping the public alive to the importance of a G-E Wiring System throughout every building.

Have you received our helpful booklet on complete wiring, "The Home of a Hundred Comforts"? Send for a copy.

Section AB-3  
Merchandise Department  
General Electric Company  
Bridgeport, Connecticut



**WIRING SYSTEM**  
*—for lifetime service*

In a G-E Wiring System these materials mean convenience—and lifetime service:

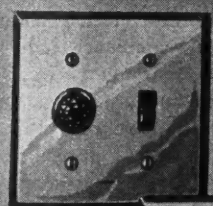

G-E Tumbler Switch with pilot to show that the current is on.



G-E Tumbler Switch—a slip of the finger works it.

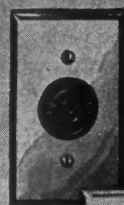

G-E Convenience Outlets sturdy for service. Plenty of outlets mean real convenience.



G-E Outlet Boxes mean protection inside your walls.

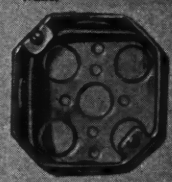

In big buildings, G-E Conduit and Code Wire serve unflinchingly.

G-E BX Cable is the flexible armored wire for permanence.

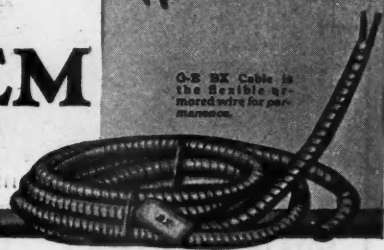

**GENERAL ELECTRIC**

# Electricity in the American Home

**U**SE of electrical appliances in the home dates back only comparatively few years but during that time its rate of growth has been amazing," says the National Bank of Commerce in New York. In the February issue of Commerce Monthly the bank says:

"The first electric lamp was marketed about 1880, and the domestic appliance industry proper had its beginning about twenty years ago. In 1924 trade estimates place total sales of appliances, fixtures and other electrical merchandise used by retail consumers (as contrasted with commercial and industrial users) at well over a billion dollars. Sales of electricity to all consumers, residential, commercial, power and other public utilities amounted to \$1,270,000,000 in 1923 and are estimated at \$1,335,100,000 for 1924. Of these totals about 50 per cent, represent sales of electricity for domestic consumption.

"Conditions resulting from the war are mainly responsible for the rapid advance in the household appliance industry, since 1914. Probably 90 per cent of all goods bought at retail are purchased by women, and the remarkable increase in sales of domestic appliances which has taken place since 1914 may be said to reflect the economic and industrial changes that have affected the average home. Between 1910 and 1920 the population of the United States increased 15 per cent. During the same period, the number of domestic and personal servants decreased nearly 25 per cent. Restricted immigration made the problem more acute. The labor saving electrical appliance helped to fill the need thus created. Other causes, however, have been contributory. Within the past two or years years the tremendous building that has been going on has been reflected in the rapid increase in the number of domestic customers. The growing popularity of apartment

dwellings and small houses has favored the use of electrical appliances. Willingness of the American public to try new things, comparatively low rates of operation, effective advertising by both light and power companies and manufacturers of appliances, all have helped advance the use of domestic appliances in the average American home.

"The use of domestic appliances improves the load factor for the electric light company, and the expansion of the household appliance field came in part from the companies' efforts to eliminate the expensive off-peak periods that occur during the greater part of the day.

"Probably the real forerunner of the modern domestic appliance was the electric fan. Its simplicity of operation and dependable performance did much to popularize the use of electricity in the average home. Today the electric iron stands far ahead among domestic electrical appliances in use, with the vacuum cleaner next, and the fan third. Of all branches of the electrical appliance industry, radio has shown the most rapid rate of expansion in the past four years. Since November, 1920, when the first radio broadcasting for entertainment took place, it has become one of the most important branches of the electrical field." ✦

## \$150,000,000 for Public Buildings

**T**HE House of Representatives, on February 2, passed a lump appropriation bill of \$150,000,000 for public buildings throughout the United States for the next five years. It is believed that a lump sum appropriation will eliminate the former practice of distributing the money according to Congressional Districts, instead of according to the real needs of the cities in which the buildings were to be erected.

## MAGNETIC BRAD DRIVER

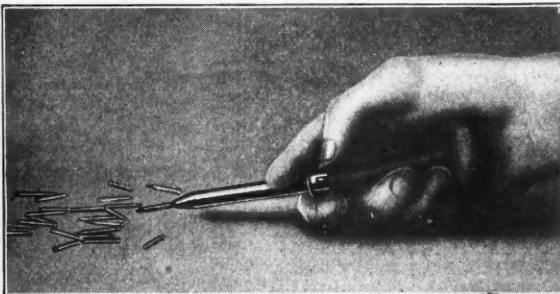

The Magnetized Ram Picks 'Em Up in a Jiffy

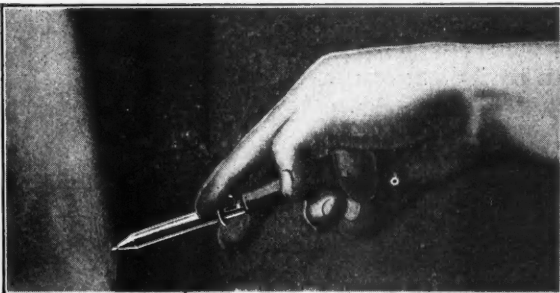

A PUSH DOES THE TRICK

SENT POST PAID ON RECEIPT OF \$1.50  
MONEY REFUNDED IF NOT SATISFACTORY  
LOTS OF 3—\$1.35 EACH      LOTS OF 6—\$1.25 EACH  
LOTS OF 12—\$1.10 EACH

**LOU MARKWELL CO.**

174 FRANKLIN ST.  
NEW YORK

75 STEUART ST.  
SAN FRANCISCO

(See our advertisement on page 75.)



**TORK  
CLOCK**

## I am a TORK CLOCK

I turn electric lights "on" and "off" regularly.  
My first cousin TORK TIMER turns 'em on and off each time you wish.

We are both standard in price and service throughout the United States.

Write for copy of Tork Manual which explains why your electrician likes TORK CLOCKS and TORK TIMERS the best for time controls.

## TORK COMPANY

8 West 40th Street, New York

TORK PRODUCTS for ELECTRICAL SERVICE

P. S. A blind man can make a perfect joint with WIRE-NUTS. If you are interested in good electrical work ask for facts regarding this material.

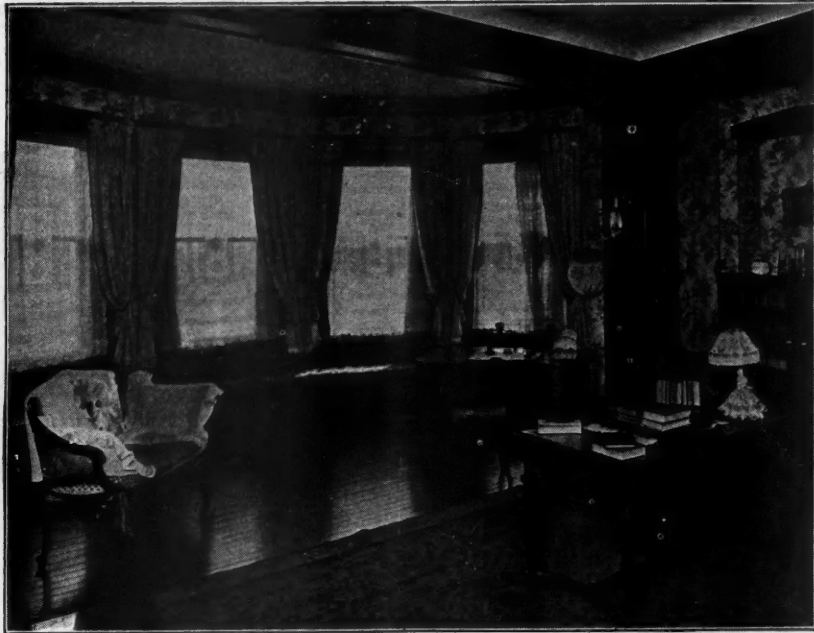

## Stained floors that keep their finish and harmonize with the woodwork in homes you build

Stained floors raise new problems for builders. Aside from the need for a flooring-wood tough enough to resist moving feet and furniture, you need a wood which assures permanence of the stain itself.

You need a flooring of such fine fibre and delicate grain that the stain penetrates evenly and harmonizes with the woodwork in the home.

Beech and Birch floorings meet these needs. They are therefore winning rapidly increasing favor with builders and owners for use as stained floors, in addition to their extensive use in their beautiful natural colors, when waxed or varnished. They give you the remarkable hardness of Maple, combined with a texture for staining which sets them apart from all other flooring woods.

*When you remodel.* Contractors handling remodeling find that  $\frac{3}{8}$ -inch Maple, Beech and Birch floorings give them an opportunity to make old floors new at less than carpet cost. Lay this special "thin" flooring right over old floors—without disturbing doors and baseboards. It gives all the surface beauty of these three attractive floorings—and will outlast any ordinary home or residence building.

Write the MFMA Library for

"Color Harmony in Floors"

"New Floors for Old"

"The Floors for Your Home"

These booklets will be sent free on request.

MAPLE FLOORING MANUFACTURERS ASSOCIATION  
1053 Stock Exchange Building, Chicago

### Guaranteed Floorings

The letters **MFMA** on Maple, Beech or Birch flooring signify that the flooring is standardized and guaranteed by the Maple Flooring Manufacturers Association, whose members must attain and maintain the highest standards of manufacturing and adhere to manufacturing and grading

rules which economically conserve every particle of these remarkable woods. This trade-mark is for your protection. Look for it on the flooring you buy.

# MFMA

# Floor with Maple

## Beech or Birch

WHEN WRITING ADVERTISERS PLEASE MENTION THE AMERICAN BUILDER



SHERARDUCT

OVALFLEX

FLEXSTEEL

FLEXTUBE



## Better Wiring for Better Lighting



If you are planning electrical wiring send for this illustrated book "Better Wiring for Better Lighting." It's free.

**N**O MATTER how fine the building there is trouble ahead if the hidden wires—back of walls, buried in concrete—are not properly protected against corrosion, temperature changes and actions of the elements.

National Metal Molding Company conduits provide protection that will last as long as the building itself and there is a type for every need. **SHERARDUCT** is an easy-bending rigid conduit, protected inside and outside by an alloying of pure zinc with steel pipe. Hundreds of the finest public buildings in America are protected with Sherarduct. **ECONOMY CONDUIT**, another rigid type is protected by double-dipped acid-resisting enamel baked on. **FLEXSTEEL** is a flexible armored conduit designed for rough usage and **OVALFLEX**, a similar type, can be laid on wall surfaces without cutting or grooving, and then be completely covered with plaster. **FLEXTUBE**, a non-metallic conduit, is built with solid walls like a cord tire and **METAL MOLDING** is a surface raceway for wires, easily installed where concealment is unnecessary.

LITERATURE DESCRIBING THESE PRODUCTS  
WILL GLADLY BE SENT ON REQUEST.

# National Metal Molding Company

1437 Fulton Building, Pittsburgh, Pa.

[No. 25]

ECONOMY CONDUIT

METAL MOLDING

WIRES

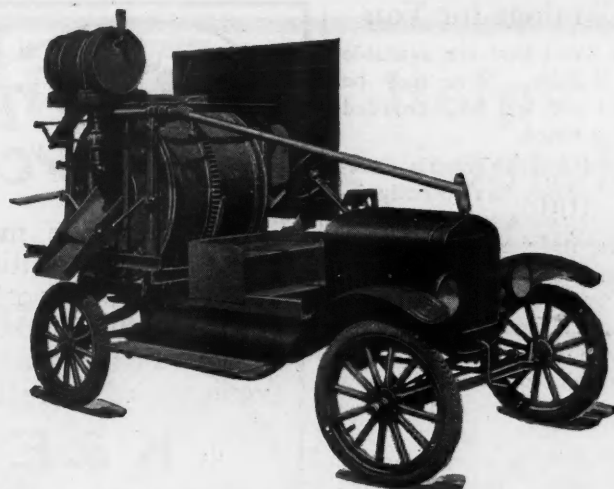

The Auto-Mixer with platform in position for moving to the next job.  
"In Position for Moving to Next Job"

## MAKE MONEY WITH ARCHER EQUIPMENT

Archer Equipment will speed up production and cut expense because of sturdy construction and ease of operation. When equipped with Archer Hoist Tower Equipment, Speedmobile and Archer Mixer, you can handle any job at a profit.

The Speedmobile consists of an Archer one-bag mixer on a Ford one-ton truck with Archer power take-off for transmitting power of Ford engine to mixer. Equipped with charging skip and paving chute. Makes a combination of dependable mixer and engine which results in a saving of men, time and money. Pay for themselves on their first big job.

The Archer Mixer is a quick loading, end discharge machine, easily moved from job to job. Made in two sizes: half sack capacity and one bag capacity. Detailed information on the Archer Line is contained in our illustrated catalogs.

SEND FOR CATALOGS.

### ARCHER IRON WORKS

2439 W. 34th Place

CHICAGO, ILL.



Speedmobile

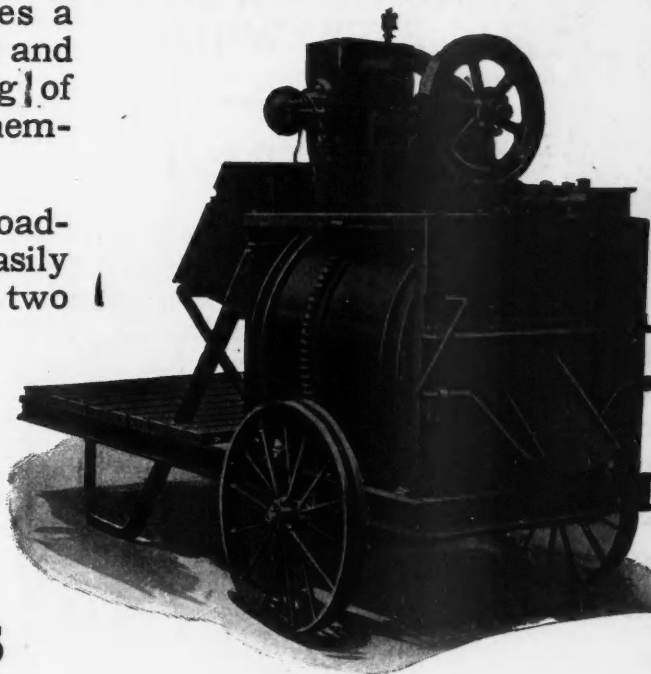

Archer Mixer

**Books, Bulletins and Catalogs for You**

THE literature and publications listed here are available to readers of the American Builder. They may be obtained from the firms mentioned and will be forwarded without cost except where a price is noted.

"Structolite Homes." The United States Gypsum Company, 205 West Monroe Street, Chicago, has recently issued an illustrated booklet under the above title describing this fireproof building material and its merits in the construction of permanent, fireproof dwellings. The material is a gypsum concrete, poured in forms, said to have great strength and heat insulating value. Halftone reproductions of construction photographs show a number of dwellings built of this material and sheets of blue print details show several types of Structolite wall and chimney construction and finish.

"Wood Preserving News," the monthly publication of the American Wood-Preservers' Association, 1146 Otis Building, Chicago, Ill., contains information for those interested in prolonging the life of wood by various processes of treatment.

"The Wood Universal" is published monthly by the North Carolina Pine Association, Norfolk, Va., at a subscription rate of one dollar a year. It is devoted to the production and use of southern pine products.

"Alpha Aids," No. 40, of the Alpha Portland Cement Company, Easton, Pa., contains two interesting articles on the proper methods of storing cement and the making of cement blocks on the farm.

The Beardslee Chandelier Manufacturing Company, 216 South Jefferson St., Chicago, has just issued a new catalog (S-7) containing illustrations, descriptions and prices of between 400 and 500 chandeliers and brackets. The thing that will particularly interest dealers in this catalog is the fact that every item listed can be shipped within 24 hours after receipt of order.

**ALLMETAL WEATHERSTRIP**

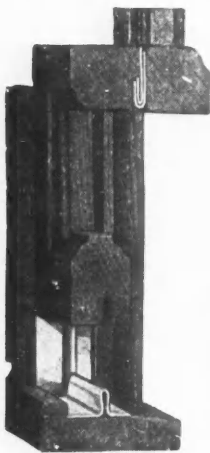

**AGENTS WANTED EVERYWHERE**

**JUST TRY IT—**

then judge for yourself why an ALLMETAL AGENCY is profitable. Any carpenter or mechanic can install it quickly and easily. NO EXPERIENCE REQUIRED.

All orders filled and shipped promptly within 24 hours after being received.

----- SEND BACK THE COUPON -----

ALLMETAL WEATHERSTRIP CO.  
231 W. Illinois St., Chicago, Ill.

GENTLEMEN:—Without obligation, please send me samples and literature.

NAME.....

ADDRESS.....

CITY..... STATE.....

WHEN WRITING ADVERTISERS PLEASE MENTION THE AMERICAN BUILDER

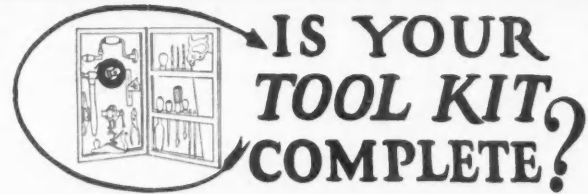

"Workmanlike manner" presupposes strict attention to ACCURACY. To base your work on exact measurements, you should use a reliable Steel Tape. For accuracy, durability, and convenience of operation, none can surpass

**K & E MEASURING TAPES**

Precise  
Durable  
Exclusive  
Patented  
Features

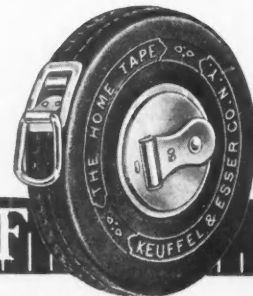

See Our  
Products  
Displayed  
at Your  
Dealer's



FREE: A Tape Catalog Is Yours. Write Us Now!

**KEUFFEL & ESSER CO.**

NEW YORK, 127 Fulton Street,

General Office and Factories, HOBOKEN, N. J.

CHICAGO

ST. LOUIS

SAN FRANCISCO

MONTREAL

616-20 S Dearborn St

817 Locust St

30-34 Second St

5 Notre Dame St. W.

Drawing Materials, Mathematical and Surveying Instruments, Measuring Tapes.



CONCRETE ENGINEERING COMPANY  
Dept. 13 1926 So. 52nd Ave. Chicago, Ill.

Weatherstrip Agents! Compare our proposition. Here is the CREAM!

**"WHITE" Door Beds and Space Saving Devices**

LESS SPACE

MORE REVENUE

GREATER COMFORT

For Homes, Apartments, Hotels and other residential buildings.

The "WHITE" Door Bed Company

130 N. Wells St., Chicago, Ill.



# This **BIG SIZE** helps *hold down* building costs!

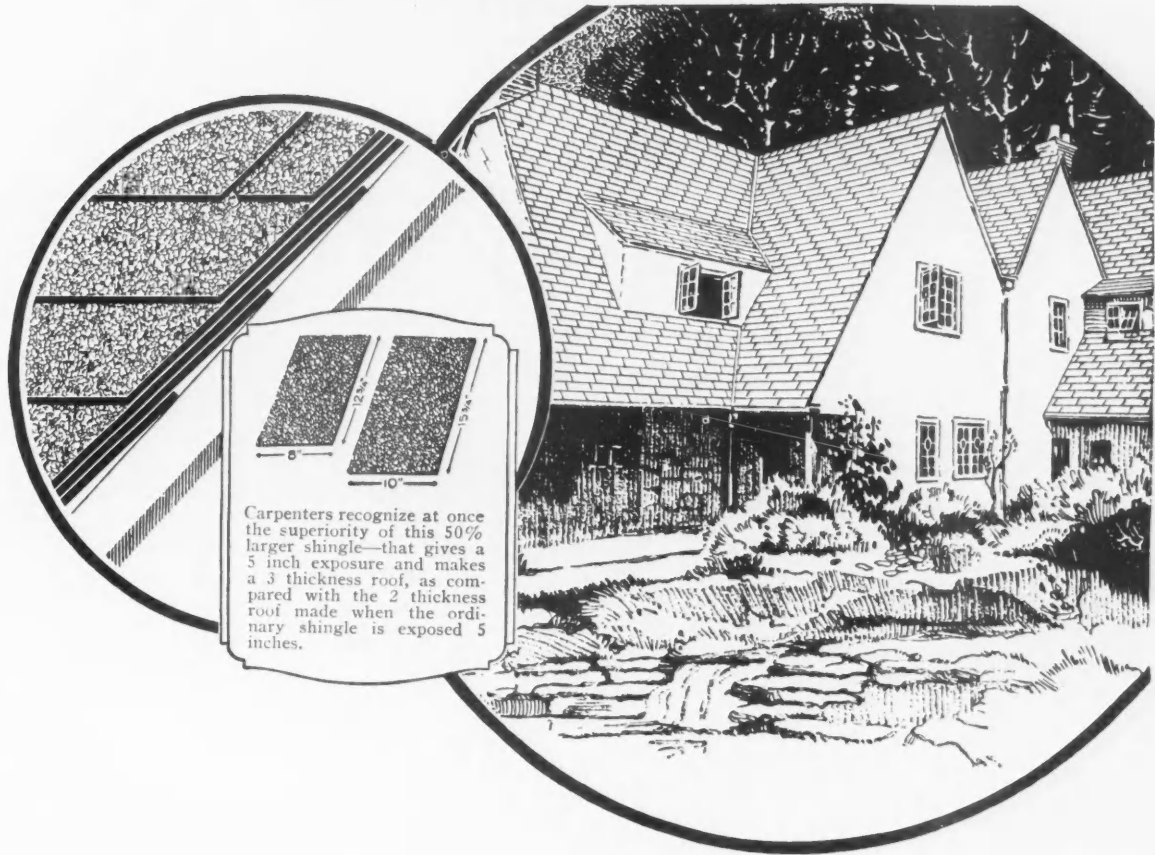

Carpenters recognize at once the superiority of this 50% larger shingle—that gives a 5 inch exposure and makes a 3 thickness roof, as compared with the 2 thickness roof made when the ordinary shingle is exposed 5 inches.

**Y**OUR biggest problem is to keep construction work within estimates and not sacrifice quality. In the roof, you can help do this by using the **BIG SIZE Carey Asfaltslate Shingle**.

First of all, it answers every requirement; it is attractive, durable and it protects.

But it also is economical in that it may be applied quicker, easier, and at much less expense. The size, 10 by 15¾ inches, means that you use fewer shingles, fewer nails, and at the same time have a three-thickness roof with a 5 inch exposure.

The completed roof is in every way superior. It is permanent. This shingle weighs approximately 300 pounds to the square. There is a deep shadow line that enhances the natural slate surface. It comes in the new and distinctive silver-green, blue-black and red.

Finally, it is "the Shingle that Never Curls"—the shingle that most well-posted home owners want.

Use the **BIG SIZE Carey Asfaltslate Shingles** on your next job and prove to yourself that it will help cut costs. Ask your dealer or send coupon for complete information.

**THE PHILIP CAREY COMPANY**  
510-530 Wayne Ave., Lockland, Cincinnati, Ohio

**Carey**  
ASFALTSLATE  
**SHINGLES**  
**THE SHINGLE THAT NEVER CURLS**

THE PHILIP CAREY COMPANY,  
510-530 Wayne Ave., Lockland, Cincinnati, O.

Gentlemen: Please send copy of "Before You Build" booklet to

Name \_\_\_\_\_

Firm \_\_\_\_\_

Address \_\_\_\_\_

### Books, Bulletins and Catalogs for You

THE literature and publications listed here are available to readers of the American Builder. They may be obtained from the firms mentioned and will be forwarded without cost except where a price is noted.

The Jaeger Machine Company, Columbus, Ohio, in its new catalog, No. 25, supplies full information in regard to the complete line of concrete mixers which it manufactures. This catalog contains descriptions and illustrations of each mixer as well as the hoists and engines.

Richardson & Boynton Company, 260 Fifth Avenue, New York City, has established a time payment plan to assist dealers in marketing its line of heating and cooking apparatus. This plan is described in a small booklet and necessary printed forms are supplied with it.

U. S. Bureau of Standards, Circular 192, is issued by the government printing office for five cents a copy. It contains specifications for asphalt prepared roofing based on a four years' investigation by the Bureau, in co-operation with manufacturers and large consumers of this material.

"How Structures Withstood the Japanese Earthquake and Fire," published by the Portland Cement Association, is a report prepared by H. M. Hadley, district engineer in charge of the Seattle office of the association. It tells the story of concrete resistance to the earthquake and the causes of failure where damage was done.

"Novo Power," published by the Novo Engine Company, Lansing, Mich., started its seventh year with the January issue which contains descriptions of the various types of gasoline power plants which the company manufactures for hoists, concrete mixers, pumps and similar machinery and tells some of the stories of Novo accomplishments.

## If You Knew—

That you could save the price of this Saw Rig on a single job would you be interested?

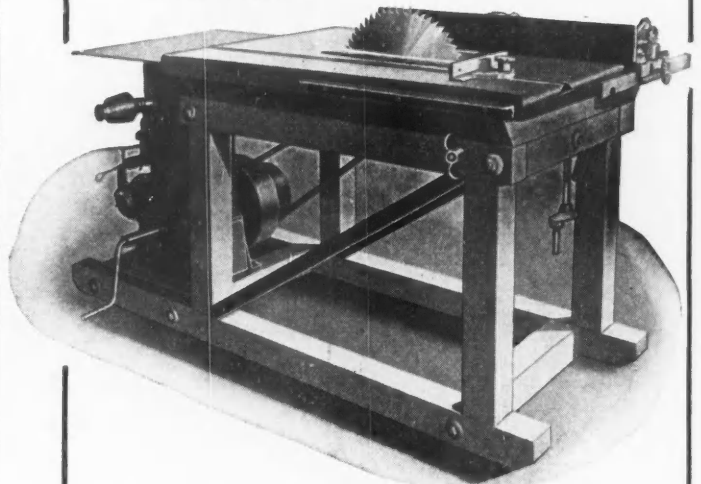

No. 2 Superior Contractor's Rip and Crosscut Saw, can be furnished with boring, mortising, emery wheel, sand disc and jointer attachments.

Let us quote you prices.

**Jones Superior Machine Co.**

1260 West North Avenue

CHICAGO, ILL.

## You Paint to Make Money— Painting the DeVilbiss Way Will Increase Your Earnings

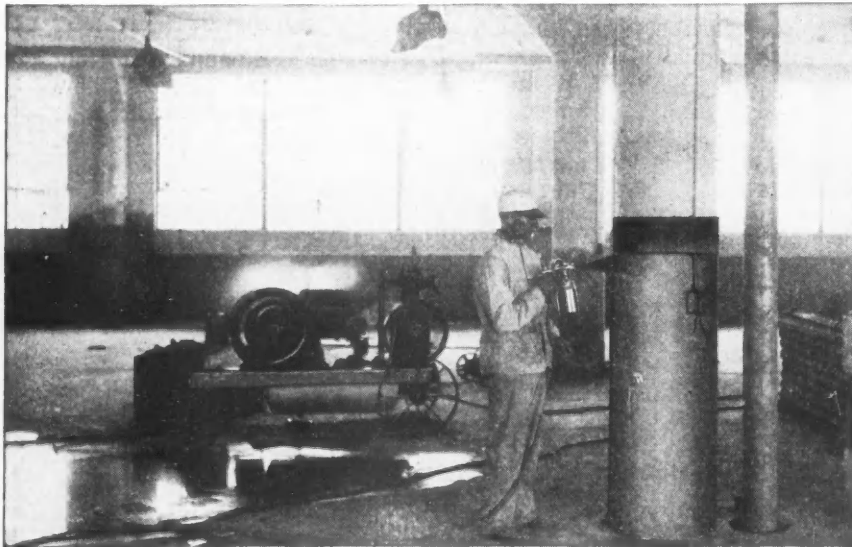

[Painting the dado—here the operator is using the DeVilbiss spray gun with Type] K N Pressure Feed Cup attached, which is advantageous on many kinds of work]

# DeVilbiss

## Spray-painting System

Doing at least two painting jobs in the present working time of one; doubling your profits, or better; improving your service; taking prompter and better care of your customers—these are some of the greater money-making advantages of painting with the DeVilbiss Spray-painting System.

In addition, painting the DeVilbiss way gives to your work the stamp of progressiveness and makes for a more satisfied crew of painters.

The speed of DeVilbiss spray-painting averages 4 to 5 times faster than hand-brushing. The spray-applied coating completely covers the surface, and is even and uniform regardless of character of surface painted and kind of paint used. The best possible results are produced with the DeVilbiss spray gun at the lowest practicable air pressure and without drips and spatters.

Here is opportunity for making a worthwhile increase in your earnings. Additional operation and equipment details of the DeVilbiss System will be promptly mailed to you. Address—

THE DEVILBISS MFG. CO.  
238 Phillips Ave. TOLEDO, OHIO

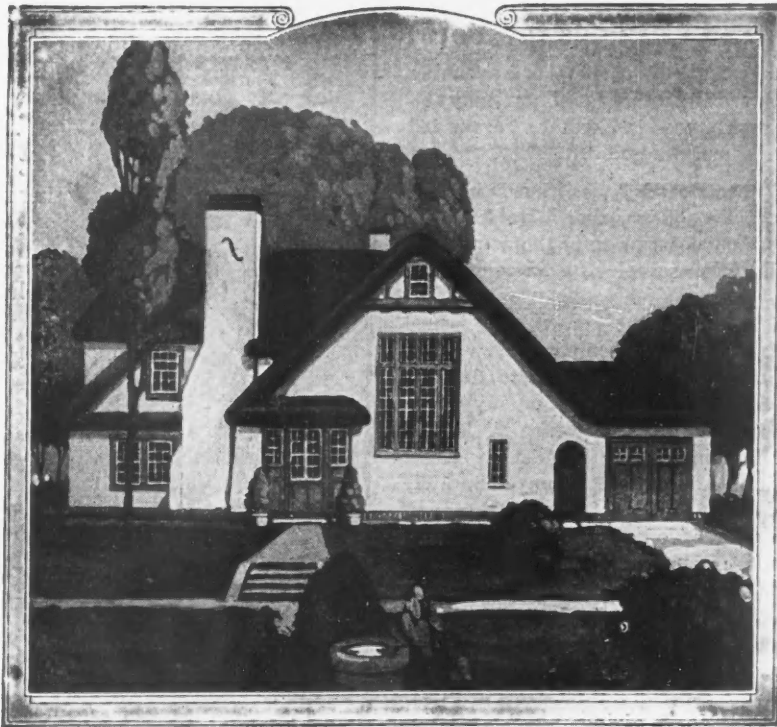

## *Building for the Future*

**Y**OUR reputation as a builder depends on the skill and care you use in constructing your buildings and on the material you put in them.

ASBESTONE Everlasting Magnesia Stucco has for 18 years demonstrated its superiority to contractors and home owners. Its elasticity and great tensile strength insure permanence and smoothness of surface.

In building with ASBESTONE you are using the best the market affords and at a very reasonable price.

Ask your dealer or write us for samples in color tints and pebble dashes. Ask for our new ASBESTONE book.

FRANKLYN R. MULLER, Inc.  
208 Madison Street, Waukegan, Ill.

# ASBESTONE

EVERLASTING MAGNESIA STUCCO



*ASBESTONE Stucco for Exteriors* ✦ *ASBESTONE Plaster for Interiors*

WHEN WRITING ADVERTISERS PLEASE MENTION THE AMERICAN BUILDER



**Books, Bulletins and Catalogs for You**

**T**HE literature and publications listed here are available to readers of the American Builder. They may be obtained from the firms mentioned and will be forwarded without cost except where a price is noted.

"Cory Bulletin and Tack Boards," is issued by the Armstrong Cork Company, Pittsburgh, Pa., in folder form for filing. It contains complete description of the company's bulletin and tack boards with sample specifications for installations.

"T & B Registers and Grills," is the new catalog issued by the Tuttle & Bailey Manufacturing Company, New York City. It is a 76-page book containing complete descriptive matter, prices and illustrations of the company's line.

The Murphy Varnish Company, of Newark, N. J., and Chicago, Ill., has issued two interesting booklets. "Eight Periods—and Their Modern Adaptation" is an elaborately illustrated description of eight styles of architecture and the characteristics which they have contributed to present-day buildings. "The Book of Decoration" is a companion booklet on the application of these period styles to decorations and furnishings.

"Metal Lath News," published by the Associated Metal Lath Manufacturers, Inc., 123 W. Madison Street, Chicago, Ill., contains, in No. 5, Vol. II, an insert, Design Data for Metal Lath Construction No. 3, giving the construction detail for stucco walls, with drawings showing the method of installing steel sash, insulation and flashing in back-plastered metal lath stucco walls.

"Dutch Boy Quarterly," a publication of the National Lead Company, 111 Broadway, New York City, contains, in the current issue, articles on "New Glazing Methods," "Wood Staining" and "Painting a Motor for Salt Water Use."

**STEEL POLES**

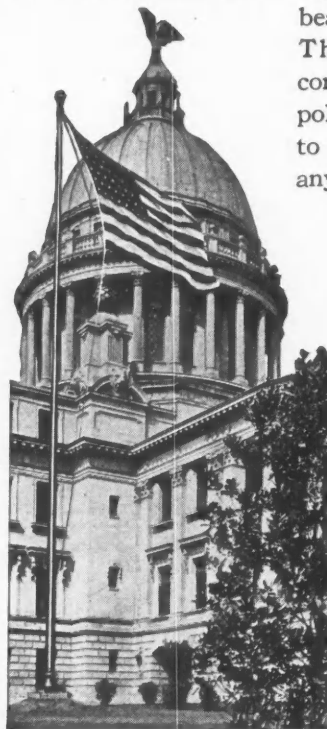

**A**DD to the setting of an attractive building by enhancing the beauty of the grounds. The flag, flying from continuous taper welded poles is the greatest asset to the attractiveness of any structure.

Write for catalog, price list on our tubular poles and sketch to meet your requirements.

**THE POLE AND TUBE WORKS**

Inc.  
Exclusive Pole Specialists  
NEWARK, N. J.

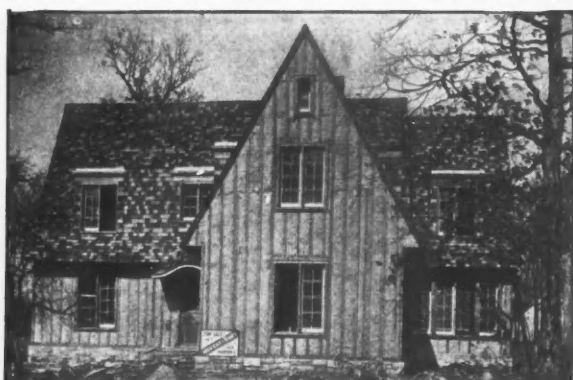

House near Chicago, showing its "underclothing" of Cabot's Quilt, with "wiring strips" over the Quilt, on which the outside finish is laid. Roof also insulated. Leon E. Stanhope, Architect, Chicago

**Underwear for Houses**

Underclothing makes people warm because it prevents the heat of their bodies from escaping. You can make your houses warm in the same way.

**Cabot's Insulating Quilt**

prevents the house heat from escaping. It insulates the whole house and saves the heat from the heater—that costly heat. It keeps the house warm on the smallest amount of coal; saves one-quarter to one-half of the coal bill. Makes the house comfortable for all time. Preserves health and saves doctor's bills. Makes the house cooler in summer. Quilt is not a mere felt or paper, but a scientific insulator that makes the house like a thermos bottle.



Sample of Quilt with full details and references to dozens of users, sent FREE on application.

**SAMUEL CABOT, Inc.,** Mfg. Chemists  
BOSTON, MASS.

342 Madison Ave., New York  
24 W. Kinzie St., Chicago

Cabot's Creosote Stains, Conserve Wood Preservative, Stucco & Brick Stains, Damp-Proofing

**STOP**



**HEED**

**BUY THE BEST HARDWARE FOR HARD-WEAR**

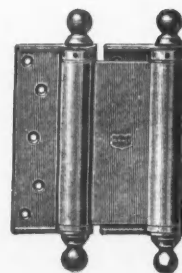

**UTILITY DURABILITY BEAUTY IN THE BOMMER**

**BOMMER SPRING HINGES ARE THE BEST**

Your DEALER handles them, Get New Catalog 47, you need it.

**BOMMER SPRING HINGE COMPANY**  
MANUFACTURERS  
BROOKLYN, N. Y.

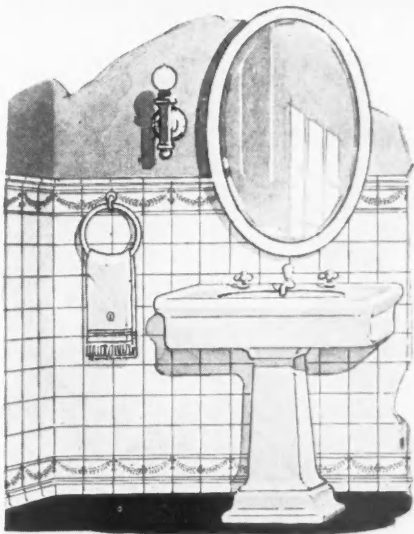

## All the Beauty of Tile~ at one half the Cost!

Imagine enameled metal tile whose colors, sheen and finish perfectly rival real tile; that is rust-proof, easy to lay, can be cemented perfectly to any surface and bent round corners of walls without cracking or chipping; that is non-absorbing and absolutely sanitary. And then realize that the cost is about one-half that of tile!

That, in brief, is a visualization of SANI-TILE—the perfect enameled metal tile—now finally available in adequate quantities in America.

A sample of SANI-TILE and all information gladly sent. Simply make your request on your own letterhead. Write today!

### Representatives and Distributors Wanted

The advertising and merchandising campaign behind SANI-TILE and the enormous need for this product are factors that combine to make the SANI-TILE franchise an exceedingly valuable one. There are still a number of territories open, for which we will be glad to outline to anyone interested a most liberal proposition. The nature of the opportunity requires immediate communication by letter or telegraph.

**Used in the Most Famous Hospitals, Hotels, Restaurants and Royal Mansions in Europe.**

SANI-TILE comes in many designs and colors from which may be selected the ideal decorative scheme for any particular job. The border used at the bottom of this advertisement is but one of the many beautiful border designs in which SANI-TILE is manufactured.

**SANI-TILE COMPANY** Main Office—290 Third Street  
MILWAUKEE, WISCONSIN

For Stores, Homes, Tea Rooms, Restaurants, Office Buildings, Public Buildings, Apartment Houses, etc., etc.

TRADE MARK  
**SANI-TILE**  
THE PERFECT ENAMELED METAL TILE

For walls and ceilings of Lobbies, Pantries, Kitchens, Hallways, Bathrooms, Operating Rooms, etc., etc.



## SLATE THE HIGHEST VALUE AT THE LOWEST COST



The cost of any roof *cannot* be ascertained at the time of purchase—only after the years collect their toll of repairs can the true cost be known.

The first cost of a SLATE ROOF is not any greater than the average, but taking into consideration its long life and freedom of repairs, it is considerably lower in price than the flimsiest roofing paper. Let us prove it.



**VENDOR SLATE CO.**  
INCORPORATED  
EASTON, PENNSYLVANIA



# Something New Under the Sun for Building Contractors

Every Builder who reads this and acts upon it will be in a position to save money on his painting and yet do better work.

An Outside High Gloss Paint of unusual whiteness has been perfected and is being offered to Builders. For five years this paint has been used on buildings in various parts of the country and has stood the test of time. This paint is now ready for you to use.

The formula was developed by the New Jersey Zinc Co., and this is assurance in itself that the product must have unusual merit. This paint is now being manufactured in our modern factory in accordance with the specification of the N. J. Zinc Co. It is known as Tropolith 40-40-20.

## TROPOLITH 40-40-20

This paint costs less, both in the can and on the surface, than other first grade Outside Whites now on the market. But that is not all—it has much better hiding power and spreading capacity; it outwears other exterior paints and makes a fine repainting surface. One great advantage in using Tropolith 40-40-20 is that it will not darken in contact with the sulphur gases found in the air in most cities, while ordinary lead and oil is greatly affected by such gases.

Tropolith 40-40-20 is manufactured in white only, but takes tinting colors wonderfully well. It is made in both liquid and paste forms and is sold direct to Builders and other large users of paint. Tropolith 40-40-20 is not sold through dealers.

Send the coupon below for prices of Tropolith 40-40-20 and our booklet showing the results of actual tests against present day paints and pastes.

THE TROPICAL PAINT & OIL CO., 1232-1274 W. 70th St.  
CLEVELAND, OHIO



THE TROPICAL PAINT & OIL CO.,  
1232-1274 W. 70th St., Cleveland, Ohio.

Yes, I'd like to have more facts and Builder's prices on Tropolith 40-40-20. Am also interested in items checked below:

- Cementkote, for concrete and stucco.
- Elastikote, for exterior wood, brick or metal.
- Roofkoter, for waterproofing old roofs.
- Waterproofing Paint, for use below the grade line.
- Toconamel, gloss wall enamel.
- Floorkote, for cement floors.

NAME .....

STREET AND NUMBER.....

CITY..... STATE.....

3-25

# Make Sure NOW That You Choose the RIGHT Combination "Portable"

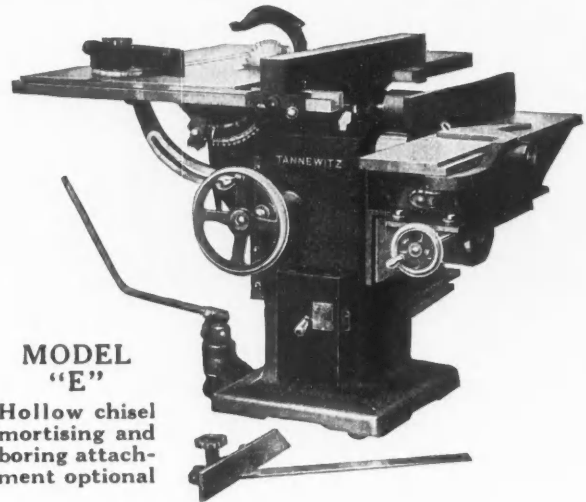

MODEL "E"

Hollow chisel mortising and boring attachment optional

**Y**OUR profits for the next season, and many seasons to come, will be greatly affected by the quality, dependability and usefulness of the "Portable" you buy now.

Consider then some of the qualifications that make the Model "E" the best possible investment of this kind to be had.

This machine not only rips, miters, cross-cuts, bevels, grooves, gains, rabbets, joints and planes, but performs all these operations as well as the finest individual machines.

It is solid and substantial because of the quality built into every part of it; compact, yet readily accessible; easily moved from place to place—a machine that cannot fail to give you many years of dependable, trouble-free service.

Before making a choice, by all means write for Bulletin E, which fully describes this splendid machine. It will show you what a *real* machine, a combination "Portable" can be.

**The TANNEWITZ WORKS**  
Sawing Machinery Specialists  
GRAND RAPIDS, MICH.



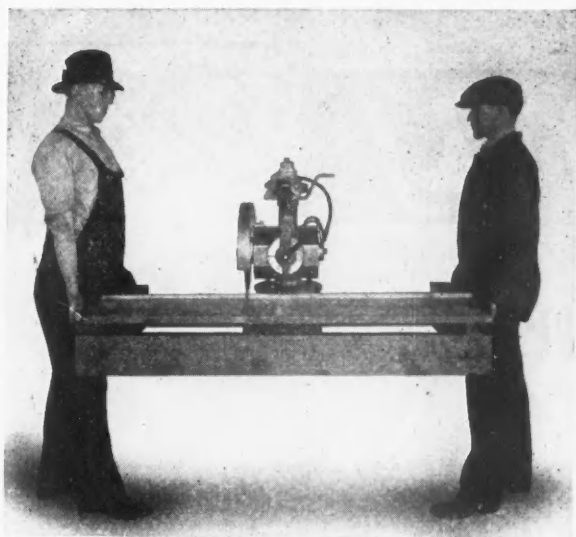

A Truly Portable Machine

## The DeWalt Woodworker

saves money on 18 wood working operations necessary on every job. This is 18 opportunities to make money with the lightest portable bench machine obtainable. And you can change from one operation to another in from five to ten seconds.

The first cost, which is moderate, is soon forgotten—profits and the time gained in completion of contract being constant reminders of the accuracy and dependability of the DeWalt machine.

A real direct Motor Drive—no gears—no belts; all cutting tools mounted direct ON motor shaft; instant change of tools or position.

**4 H. P. Model 260 lbs.**

Condensed power unit INSTANTLY available for Any Purpose in Any Position.

*The illustrations prove the portability—let us prove the practicability. Write*

### De Walt Products Co.

Leola, Lancaster County, Pa.



From Floor to Floor



## Hagarty Says—

“Architects and contractors are stuck on my ROCBOND houses, but there ain’t no trick about it.

“Just follow directions, slide on a good half inch and she’ll stick ’til the crack of doom!

“O! ROCBOND’S a square shootin’ material, but it won’t stand for abuse more’n any other good thing.”

# ROCBOND

## Exterior Stucco

*A Good Half Inch*

|| FOUR PLANTS ||

Write the one nearest you.

### The Rocbond Company

Van Wert, Ohio  
Cedar Rapids, Iowa

Harrisburg, Pa.  
New York, N. Y.

The Rocbond Co.

A. B.

Please send me “Homey Homes” book describing Rocbond Stucco. No obligation is assumed.

Name.....

Address.....

If Looking For

# Economy

Ask us about our famous  
**Ideal Vertical Stripper**

## Investigate the remarkable IDEAL POWER ROLL-OVER STRIPPER

which makes the world's lightest, strongest tile MOST ECONOMICALLY and we can prove it! In fact, the Ideal Roll-Over—high speed—is the only practical machine for stripping block or tile on wood pallets.

Wood pallets are economical—they cost little, they are light in weight—only one size is used on all block or tile. Yet they are not lacking in strength for they are built up with cleats on bottom, which also prevents breakage.

Additional economy is afforded through the fact that one man carries away two tile and only one man is required for offbearing—and it isn't necessary to install two machines, as the Ideal Roll-Over makes both tile and block.

Write us for complete "Roll-Over" information—NOW.

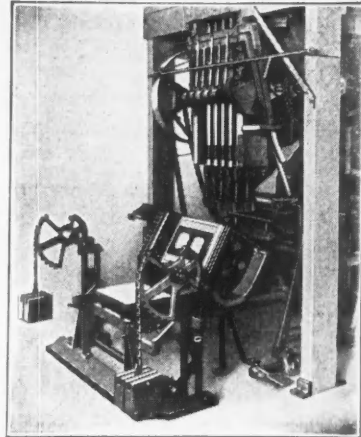

# IDEAL

THE IDEAL CONCRETE MACHINERY CO.  
5014 SPRING GROVE AVE. CINCINNATI, OHIO

TRADE MARK  REG. U.S. PAT. OFF.

## "ANTI-HYDRO" Keeps the Concrete Pits Absolutely Dry in this 'Spearmint' Factory

The concrete pits in this new Wrigley plant are permanently waterproofed with "ANTI-HYDRO," and as a result, they are *always* dry.

A one-inch cement plaster coat mixed with "ANTI-HYDRO" when applied *on the inside* of pits, walls and foundations keeps them absolutely dry against any head of water.

"ANTI-HYDRO" is extremely easy and economical to use, because it is a liquid integral compound that mixes readily with the gauging water without the aid of skilled labor. It accelerates the set of cement and so enriches the concrete that the finishers' time is reduced to a minimum.

For 20 years, "ANTI-HYDRO" has proved its economy and satisfaction on every type of hardening and waterproofing work. Use it on your next job.

## ANTI-HYDRO WATERPROOFING G.

265-269 Badger Ave.

Newark, N. J.

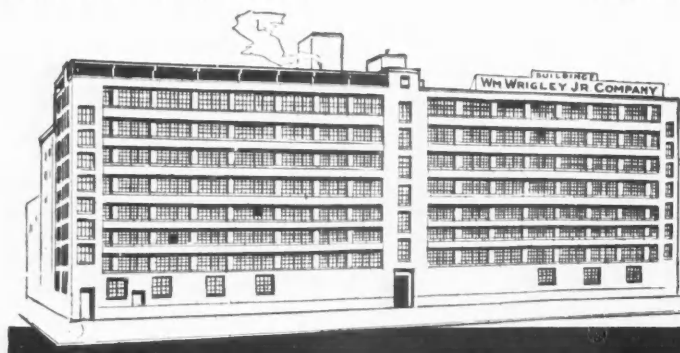

New Building for Wm. Wrigley, Jr., Co., Chicago, Ill.



Arch't. S. Scott Joy  
Contr., E. W. Sproul Co.

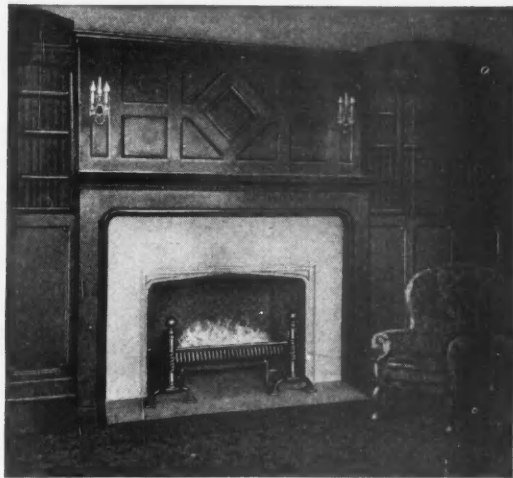
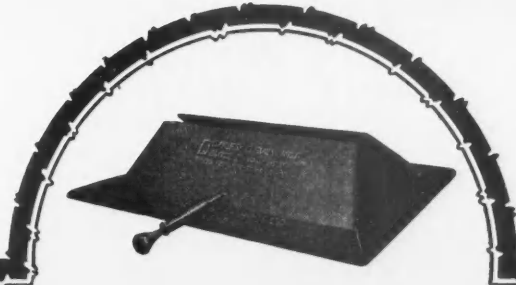

*The Fireplace Must Please  
the Housewife*

**T**HERE are no two ways about it. She's the judge. And if the fireplace doesn't burn well, smokes or smudges up with soot, you are going to hear from her.

That's one reason why successful fireplace builders are using Donley Fireplace Plans and installing the Donley Damper with its smooth metal throat that draws off fumes, gases and smoke and assures a clean, economical fire.

If you are interested in building successful fireplaces that will please the most exacting housewife you should read the Donley Book of Fireplaces. It contains many unusual and beautiful fireplace designs, complete plans and photographs of proper fireplace construction. It's yours for the asking. If you say so, we will also send you the Donley Catalog of Building Specialties.

**The Donley Brothers Co.**

13910 Miles Ave.  Cleveland, Ohio



**SUBURBAN WATER SYSTEMS**

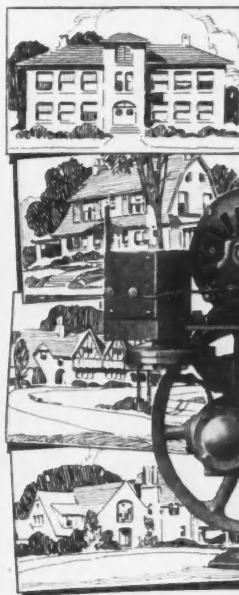

*The New*  
**DAYTON "CUB"**  
\$85

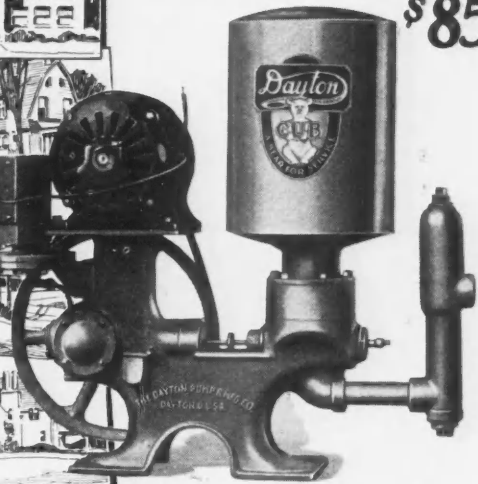

**For Dependability—  
The Guaranteed  
"DAYTON"**

**D**EPENDABILITY and performance constitute the only sound basis of comparison in water pumps—and a comparison of values on this basis invariably leads to the selection of a "Dayton".

There is a Dayton Pump manufactured to meet any requirement in city, suburb or country—for home, school, club or any other building need. They are made for deep or shallow wells or cisterns and with capacities of from 200 to 3000 gallons per hour.

A new low priced Dayton—the Dayton "Cub" may now be had for as little as \$85.00. With the same qualities of dependable construction built into it that have heretofore characterized Dayton Pumps and with a capacity of 200 gallons per hour, it is easily the outstanding value on the market.

*Write for literature on this and the complete line of pumps made by the pioneers in the manufacture of private water systems.*

**The Dayton Pump & Mfg. Co.**  
Dayton, Ohio, U. S. A.



Please send at once your catalog and prices on Dayton Pumps.



Tear off and pin to your letterhead.

Name \_\_\_\_\_  
Address \_\_\_\_\_

**"Dayton" Pumps**  
*Make the water do the running*



*“Two jobs will pay for them”*



READY FOR STUCCO

say:

Walter Smith & Sons  
Norwood, Mass.

A CLEAR  
WORKING  
SURFACE  
WITH  
ABSOLUTE  
SAFETY

NO TOOLS  
OR NAILS

**BEAVER** ALL STEEL **BRACKETS**  
FOR SINGLE POLE SCAFFOLDING

Tested to 4000 Lbs.  
Fit any 4" Surface

*Write for Illustrated Folder*

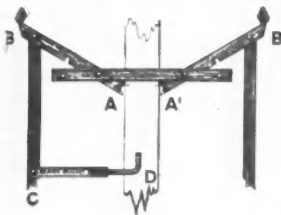

SHOWING METHOD  
OF ATTACHING TO  
POLE—set spurs A, A1  
level, then pull down  
arms B, B1, adjust  
brace C in place and  
tighten hard screw D.  
Weight 10 lbs. Folds to  
very small space.

ABSOLUTELY GUARANTEED

MADE FOR 30" AND 40" SCAFFOLDING  
ASK YOUR BUILDING SUPPLY JOBBER

**Distributors**

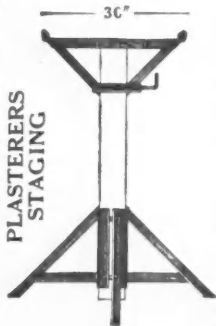

- Smith-Greene Co., Worcester, Mass.
- Springfield Contractors Supply Co.,  
Springfield, Mass.
- Windsor Cement Co., Hartford, Conn.
- Gesner Contractors Equip. Co.,  
New Haven, Conn.
- E. B. Kelley Co.,  
New York—Philadelphia.
- John C. Louis Co., Baltimore, Md.
- Construction Supply Co., Richmond Va.
- Edgar Alexander, Atlanta, Ga.
- W. M. Pattison Co., Cleveland, Ohio.
- Flack Equipment Co., Dayton, Ohio.
- Abram Cement Tool Co.,  
Detroit, Michigan.
- Standard Machinery and Equip. Co.,  
Spartansburg, S. C.
- Gierke-Robinson Co., Davenport, Iowa.
- Boeck Ma Livery Co. Inc.,  
2404 Clybourn St., Milwaukee, Wis.
- Western Supply Co., Butte, Montana.

Western & Southern Distributors Wanted  
**BEAVER METAL PRODUCTS CO., Inc.**  
80 Boylston Street, Boston, Mass.

**HERE IS A PRACTICAL  
AND INEXPENSIVE  
SAWTOOTH SKYLIGHT**

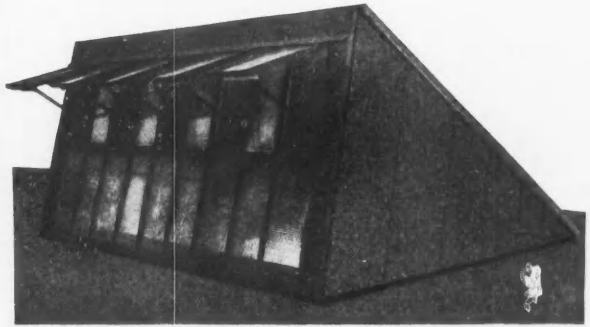

The Willis Sawtooth Skylight meets instant approval of experienced builders. Its many advantages are so apparent that it needs no sales argument—and—best of all, its price is right.

*Ask for complete  
description and  
quotation*

**WILLIS MANUFACTURING CO.**  
**GALESBURG, ILL.**

# Duplex Steel Bridging costs less installed than wood

—And yet how much better, from the standpoint of both owner and builder. Strong, light, permanent, installed in one-eighth the time, with half as many nails required.

Supplied in convenient flat bundles of 25, in six sizes for 8", 10" and 12" joists and for 12" and 16" joist spacings. Easily shipped and handled.

With its many advantages, Duplex Steel Bridging will cut your bridging costs more than half. Write at once for free sample and illustrated folder.



*Here's the old way*

Wood bridging to be cut by hand—Two pieces, each with two or more nails on each end. Always the chance of splitting, warping, and loosening, after installation.

Aputtering time and money-wasting job.

*And here's the new!*

GF Duplex Steel Bridging, in bundles ready to nail. Light, strong, everlasting. One piece and only four nails to drive. And costs less, installed, than wood.

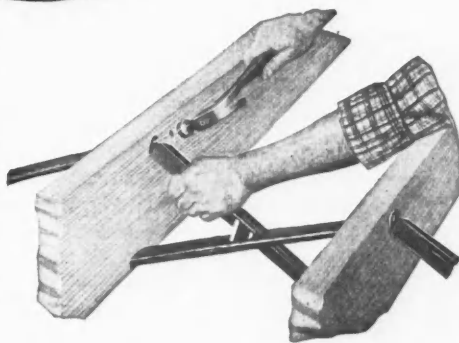

**THE GENERAL FIREPROOFING CO.**  
Youngstown, Ohio

Export Dept. 438 Broadway, New York City -- Cable Addr. "Genfire-New York"

**GF Duplex**  
STEEL BRIDGING



*Donn Barber, eminent architect, is quoted in a national woman's magazine as pronouncing this attractive home of John Wise at Relay, Md., "the best small house for its price" among those entered in a recent prize contest. Roof is of WEATHERBEST Green and sidewalls WEATHERBEST Gray Stained Shingles.*

## The Appearance Pleases —and So Does the Cost

THE key to home design of artistic beauty well within the cost limits of the average client or purchaser is found in

**Weatherbest**  
**STAINED-SHINGLES**  
FOR ROOFS AND SIDEWALLS

Their distinctive and picturesque shades win the eye at first glance—while their saving of \$100 to \$200 per house compared with the cost of weatherboarding, wins the approval of the most practical minded watcher of cost sheets. The resistance of WEATHERBEST to depreciation is equally important from the viewpoint of both appearance and economy. All WEATHERBEST Stained Shingles are strictly edge-grain British Columbia red cedar.

**WEATHERBEST STAINED SHINGLE CO., INC.**  
143 Main Street, North Tonawanda, N. Y.  
Western Plant, Minnesota Transfer, Minn.

**WEATHERBEST Stained Shingle Co., Inc.**  
143 Main St., No. Tonawanda, N. Y.

Please send WEATHERBEST color samples, literature showing lower cost of WEATHERBEST Stained Shingle Sidewalls, and book on WEATHERBEST Thatched Effect Roof Construction.

# You Can Safely Put On This Strip WHEN the HOUSE is NEW

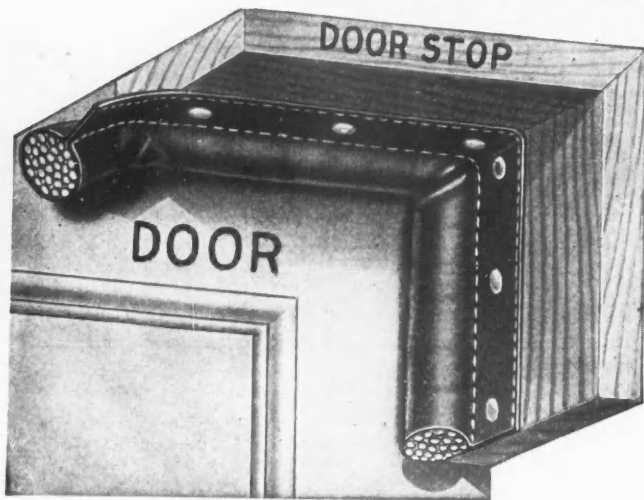

It isn't necessary to wait until the house settles before you apply Home Comfort Weatherstrip. Heretofore builders have followed this practice with other kinds of weatherstrip, and rightly too. But this new flexible strip may be applied to the house as soon as it is built, because Home Comfort Weatherstrip is flexible; if the windows and doors warp or settle after it has been applied, this strip follows the wavy surface, filling up the opening or compressing, as the case may be. Thus a weathertight, waterproof, noiseless contact is assured.

**E. J. WIRFS ORGANIZATION**  
116 S. 17th St., St. Louis, Mo.

Pat. Jan. 22, 1924.

Accept no infringement or imitation!

**EASY TO APPLY**

Simply tack on, turn the corners. The only tool needed is a tack hammer. No sawing or mitering. No taking down of doors and windows. No waste in left over ends as you can get the exact number of feet you need from your dealer or direct from us.

## WIRFS PATENTED HOME COMFORT INSULATED - CUSHION - FLEXIBLE WEATHERSTRIP

### Tested and Proven for a Generation

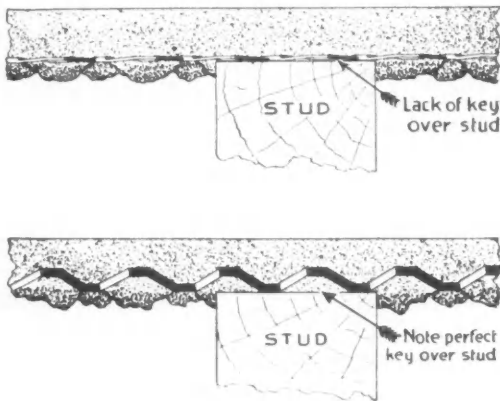

The illustrations above show the perfect key secured with Expanded Cup compared with ordinary expanded lath.

Sykes Expanded Cup Metal Lath is equally satisfactory for the overcoating remodeling job, on sheathing, or for back-plastering without sheathing.

**S**YKES Expanded Cup is the original self-furring metal lath. It was in use a generation ago—and the houses then stuccoed are still solid and unimpaired by wear and weather.

It is a remarkable fact that the sections where Sykes Expanded Cup was first used—Minnesota, Florida, California—are now the biggest markets both for stucco construction and for Sykes Expanded Cup.

In newer markets it is also a fact that one Sykes job sells another, and that the Sykes dealer finds a constantly increasing business. There is no advertisement like a satisfied customer, for either the dealer or the contractor.

Write today for a sample of this time-tested lath—more popular today than it has ever been before.

**SYKES METAL LATH  
COMPANY**

**BETTER BUILDING  
SPECIALTIES**

Niles, Ohio

*When it's shown it's sold*



SPECIAL ADVISORY COUNSEL FOR ARCHITECTS

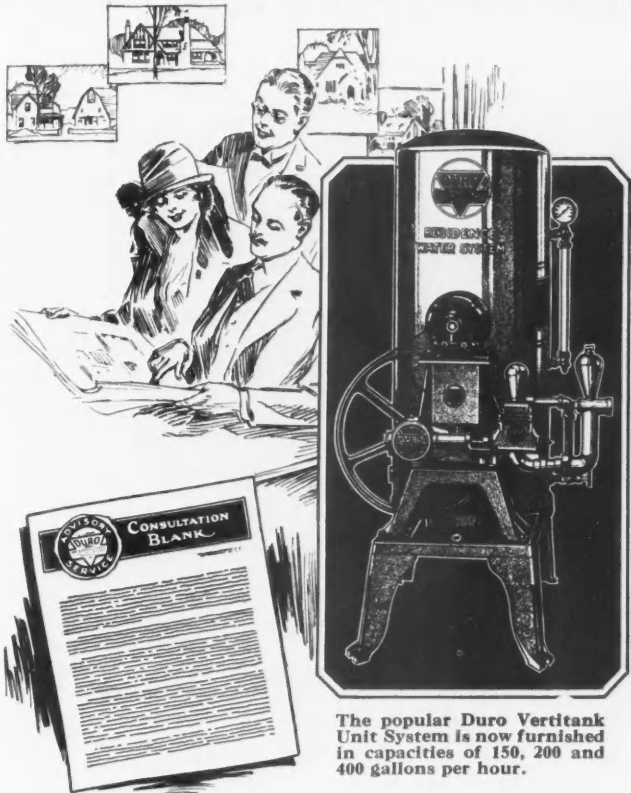

The popular Duro Vertitank Unit System is now furnished in capacities of 150, 200 and 400 gallons per hour.

## What Water System Should I Specify?

Above all, you want to give your clients satisfactory water service. And the fact that you have specified Duro is proof that they are **guaranteed satisfactory water service.**

### How to Specify Once and Wisely

It's wasteful and extravagant to specify more pumping capacity than is needed. Yet infinitely worse to select a system that is inadequate for that particular home. Can you always select the right system of the proper capacity for the particular conditions involved?

The Duro Advisory Service correctly solves your water supply problems. Duro gladly assumes the responsibility for every installation made in accordance with its recommendations.

Why not take full advantage of this helpful service? All you need do is to fill in the Consultation Blank. No obligation. The Duro Advisory Service is free.

*Write NOW for Free Consultation Blank.*

**The Duro Pump and Mfg. Co.**  
103 Monument Ave. Dayton, Ohio



AND now — an expansion shield that you drive home with a hammer. No slow, laborious turning with screw driver or wrench. Speeds up work fully 50 per cent. The nail simply expands the metal — the shield itself holds the load. Permits use of the fixture itself as a templet — insuring neater work and saving of time.

## ★ DRYVINS

Tested and approved by New York City Bureau of Buildings. Used by Telegraph and Telephone Companies, Public Service Co. of New Jersey, David Lupton Sons Co., Philadelphia, Erectors, Electrical Contractors, Plumbing Contractors, Sign Companies, Awning Companies, Builders, etc. Send for literature describing this remarkable expansion shield device.

### SAMPLE KIT

*Dryvin Expansion Shields, Dryvin Drill Point and Chuck*  
Dryvin shields, Dryvin drill point of Vanadium steel and special hand chuck that makes drilling faster and easier. Specify type of work and size of shields desired. Complete outfit—list price—averages \$1.00 \$1.60. **Special offer . . .**

Dryvin Sizes  
 3/16 x 3/8"    1/4 x 1"    1/4 x 1 1/4"  
 5/16 x 1 1/4"    3/8 x 2"    1/2 x 2 1/4"

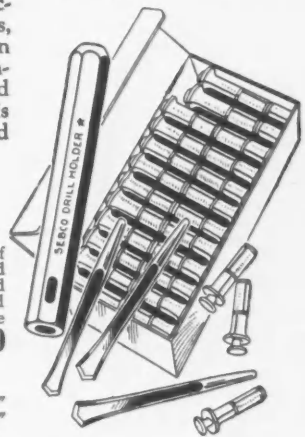

### LOXIN Expansion Shields

One half inch shorter than ordinary shield, saving time in drilling. Jam collar keeps expansion at bottom of hole. Won't work loose.

## STAR EXPANSION BOLT CO.

Established 1900

147 CEDAR STREET NEW YORK CITY

Full Stock carried at following branches:

Philadelphia Chicago Los Angeles Montreal  
 Boston St. Louis Seattle Toronto  
 Winnipeg



An old home modernized by 3/8" Oak Flooring



No woodwork is disturbed except the moulding at the baseboard. The new oak floor will be just as sound and enduring as if oak had been laid originally.



## MORE MONEY for YOU

Modernize old homes, by laying 3/8" Oak Flooring over worn softwood floors.

Many contractors and builders have increased their business by telling people in their city about oak floors.

Show them how inexpensively 3/8" oak flooring can be laid over old and unsightly softwood floors. Let women know that oak floors are clean and sanitary, that they save housework, that the cost need not be more than new carpets. Mention the permanent value added to property.



of the new color finishes. It will help you get orders, as it did Wm. J. Benko of New Brunswick, N. J., who writes, "I personally distributed 10 books, and got 6 jobs." Mail the coupon for your copies.

How to figure the exact amount of flooring required is explained in "How and Where to Use Oak Floors", also grading rules, measurements, proper laying, scraping, and finishing.

Mail this Coupon

Free books will help you

"The Story of Oak Floors" contains plates



OAK FLOORING BUREAU  
838 Hearst Bldg., Chicago

Please send me "The Story of Oak Floors," and "How and Where to Use Oak Floors."

Name.....

Address.....

City..... State.....

WHEN WRITING ADVERTISERS PLEASE MENTION THE AMERICAN BUILDER



# "Ruff-Stuff" GARNET

A clean properly graded, smooth-cutting, long-lasting, sharp-edged crystalline garnet, securely fixed to an extra-tough paper backing.

Does uniform work, with no scratches or deep lines.

You'll never know good garnet till you use

"RUFF STUFF"

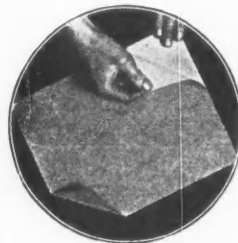
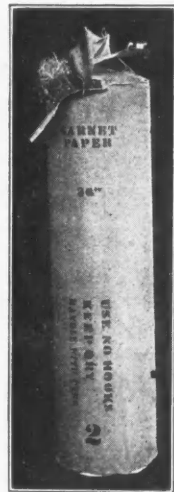

Send us a trial order, rolls of the sizes and grit-numbers that you use.

"Ruff Stuff" Garnet is also furnished in cabinet and finishing sheets, all grits. Also Garnet cloth for belts.

And don't forget Ruff Stuff Flint Papers—famous the world over.

## Wausau Abrasives Company

1025 Harrison Boulevard  
WAUSAU, WISCONSIN



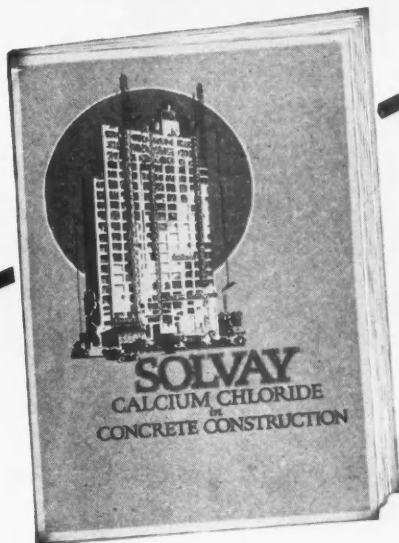

**Write for this *new* booklet today!**

The new Solvay booklet gives you the latest available information on the use of Calcium Chloride in concrete construction.

**SOLVAY  
CALCIUM CHLORIDE**

Exhaustive tests by foremost authorities prove that Solvay accelerates, waterproofs and strengthens concrete. Also protects against freezing temperatures.

Solvay will save you time, labor and money on all concrete work.

Seventy-five conveniently located distributing points assure prompt service with minimum transportation costs.

*Write for Booklet No. 1753*

**The SOLVAY PROCESS CO.**

Wing & Evans, Inc., Sales Dept.

40 RECTOR STREET, NEW YORK

Boston Cincinnati Cleveland Chicago Detroit  
Pittsburgh Syracuse Indianapolis

**"Panama"  
Concrete  
Machinery**

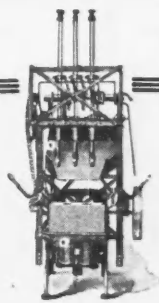

**Panama Power Tamper**

A block a minute can be turned out with the aid of this machine. No extra labor necessary. Designed for use with 8x8x16 inch block machine.

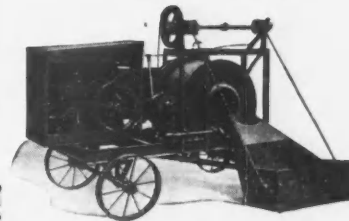

**Panama Batch Concrete Mixers with Side Loaders**

are made in 5 and 10 cu. ft. capacities. Greater efficiency is obtained as the side loader can be filled while a batch is being mixed. Simply constructed, easy to operate.

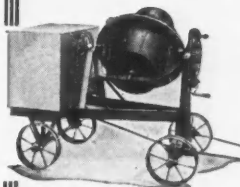

**Tilting Drum Mixers**

Capacity 4 cubic feet—loads easily and quickly. Thoroughly mixes concrete, plaster and mortar. Drum loads on right and dumps to left. Satisfactorily handles many jobs now being done by larger mixers.



**Leader Block Machine**

Capacity 100 to 250 blocks per day, or one a minute when used with the Panama power tamper. Withdraws cores vertically as box is turned over, permitting wetter mixture to be used. This insures a strong block and shortens the curing process.

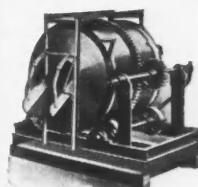

**Panama Winner Hand or Power Mixer**

Capacity 3 cu. ft. per batch under hand operation and up to 5 cu. ft. per batch with power operation. A real time saver that mixes thoroughly and quickly. Discharges into wheelbarrow or directly into mold. An ideal mixer for stationary installation.

**E**SPECIALLY in the building field time and labor saving equipment is an asset. The "Panama Line" of Concrete Mixers and Concrete Block Machinery is the most complete line ever offered and will more than save its cost in a short time.

Whether you need a small mixer for intermittent work or a large mixer for day in and day out service; a small block machine for handy uses or a complete block machine plant, the "Panama Line" of quality products will serve you better, longer and most economically.

Our complete catalog of Concrete Mixers and Concrete Block Machinery gives full description of the "Panama Line." Write for it today and save time and money.

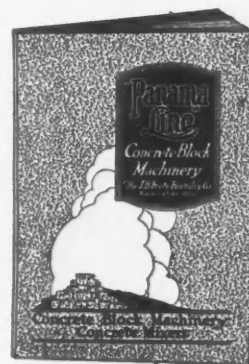

*Write name and address in this margin, tear off and mail. Catalog will be sent promptly.*

**The J.B. Foote Foundry Co. Fredericktown, O.**

Established 20 Yrs

14 FRONT STREET





## MILES ELEVATOR AND FEEDER

Saves time and labor because it eliminates handling material by hand. Conveys material from the mixer and feeds it into the block machine. Doubles production.

Can be bought complete with our power tamper and block machine or as a separate unit to be used in connection with old machines. Has proven its value by more than one year of actual service.

*Write for further information*

**MILES MANUFACTURING CO.**

Department 20

JACKSON, MICHIGAN

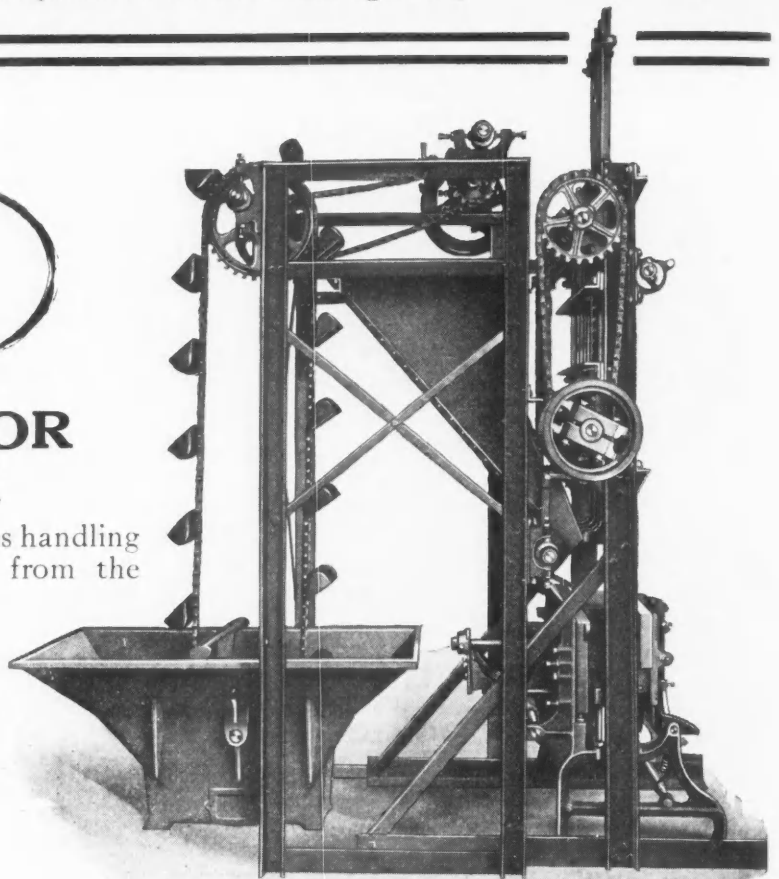

## MAKE \$25<sup>00</sup> A DAY FILING SAWS

*with the*

## FOLEY AUTO-MATIC SAW FILER

**T**HINK of the money you can make when you can file a saw in 5 minutes—and do a better job than a professional hand filer! The Foley Automatic Saw Filer makes sharpening saws quicker and easier, and it works equally perfect on hand, band, back, meat or circular saws.

With this inexpensive outfit you simply clamp the saw in the frame, turn on the motor or crank by hand, and it files every tooth to just the cutting edge you want—all in five minutes.

### Buys Itself Quickly

Since the Foley has come on the market you can't afford to sharpen saws by hand or send them out to be sharpened. As few as three saws will pay for a Foley in a surprisingly short time. The Foley lasts a lifetime because there's nothing to get out of order or wear out.

### Real Money Makers

Foley Saw Tools are making big money for many men who started in the business without any experience. They handle six times as many saws in a day—every one perfect—and bring you more than you could possibly make filing by hand. Our agency proposition also offers big possibilities to wide-awake men.

### FOLEY SETS A SAW IN ONE MINUTE

The Foley Rotary Saw Set sets a saw perfectly in one minute. Requires only one operation; you set the wheel on the saw teeth and rotate the Saw Set over the teeth at ANY SPEED. The Foley rolls the teeth apart with a quickness and accuracy that will amaze you.

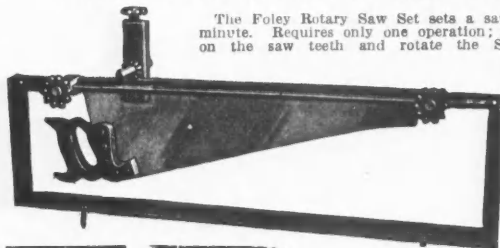

Send for Free  
Circular and Prices on  
Foley Tools.

**FOLEY SAW TOOL CO.,** 913 E. LAKE STREET  
MINNEAPOLIS, MINN.

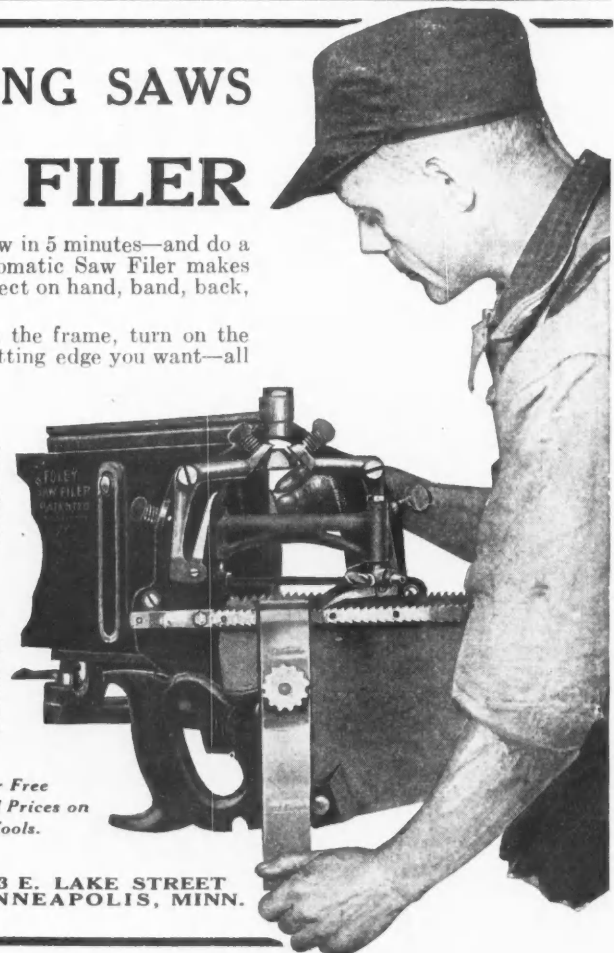



## How Syntron saved time and money on Pennsylvania's biggest hotel

**D**RILLING the thousands of holes to hang the 3600 doors in the new Benjamin Franklin Hotel, Philadelphia, the Reliance Fire Door Co., of N. Y., found the Syntron Electric Hammer a tremendous time and money saver.

Laying the many miles of carpet strips, A. Wilt & Sons Co., Phila., saved many hours and dollars by using Syntron.

And Syntron did 67 hours' work in less than two hours when the main dining room carpet was rearranged on the morning of the opening day. All the kitchen equipment was installed with Syntron, too.

### Some things Syntron will do



- Drill 3" per minute in concrete or masonry.
- Chip or channel as fast as ten men.
- Rough up smooth surface.
- Smooth rough surface.
- Cut holes for joists, etc.
- Vibrate concrete forms.
- Drive a wood chisel into the hardest wood.
- Chip slag, etc., from iron furnace.
- Spade earth in cramped quarters.
- Bead boiler tubes.

Write for full information  
National Electric Mfg. Co.  
969 Chatfield-Woods Bldg.  
Pittsburgh, Pa.

# SYNTRON Electric Hammer

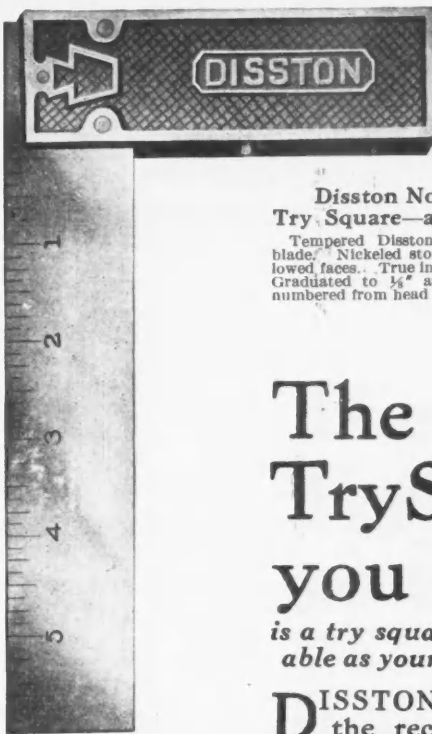

### Disston No. 5 1/2 Try Square—all metal

Tempered Disston-made Steel blade. Nickel-plated stock with hollowed faces. True inside and out. Graduated to 1/16" and correctly numbered from head to end.

## The Try Square you want

is a try square as dependable as your Disston Saw

**D**ISSTON appreciates the recognition carpenters have given the Disston Saw. For three generations, they have made it their standard of quality in tools.



### Disston Adjustable Plumb and Level

The Disston No. 16 is a popular model with carpenters. Has Disston adjustment—positive and simple. Operated by screws working in wood. No springs to get out of order. Disston quality throughout.



### Disston No. 3 Bevel

Has patented Disston Lock. Easy to set. It cannot slip. A quarter turn of the thumb-screw locks it. Nickel-plated iron stock; tempered blade of Disston-made steel.

You can get this same standard of tool satisfaction in your Try Square, too, by choosing a Disston.

Tempered blade of Disston-made Steel does not buckle. It always lies flat on the work. Steel blade is properly numbered from head to end.

Stock is accurately fitted to blade. Blade and stock are permanently fastened with steel rivets.

It costs no more—but it's worth a lot—to own a tool you can trust.

Ask your hardware man to show you a Disston Try Square.



"The Saw Most Carpenters Use"

Henry Disston & Sons, Inc.

Makers of  
"The Saw Most Carpenters Use"

Philadelphia, U. S. A.



# DISSTON SAWS TOOLS FILES

# Economical Steel Designs

## Pave the Way To Profitable Contracts

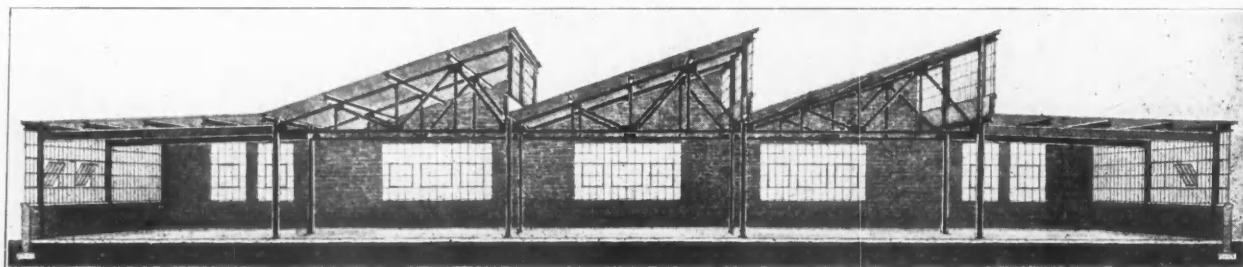

Our Engineering Department can be of great assistance to you by solving  
**FREE OF CHARGE** your Steel Problems.

We make  
Designs and Estimates  
for  
Factories—Garages—Store Buildings—Warehouses

## International Steel & Iron Co.

Address Dept. 18  
EVANSVILLE, INDIANA

Write for "Garage Illustrations" Showing at least 50 Modern Buildings designed by us.



### HE KNOWS

The Owner Knows The  
Value of a Bearcat  
Woodworker.

### He has put it to Test

"My only regret is that I did  
not purchase a BEARCAT  
several years ago. My figures  
show that it paid for itself on  
two jobs."

Chris. J. Jackson, Contr.

*Scores of letters  
like this prove that*

### The Bearcat Makes Good

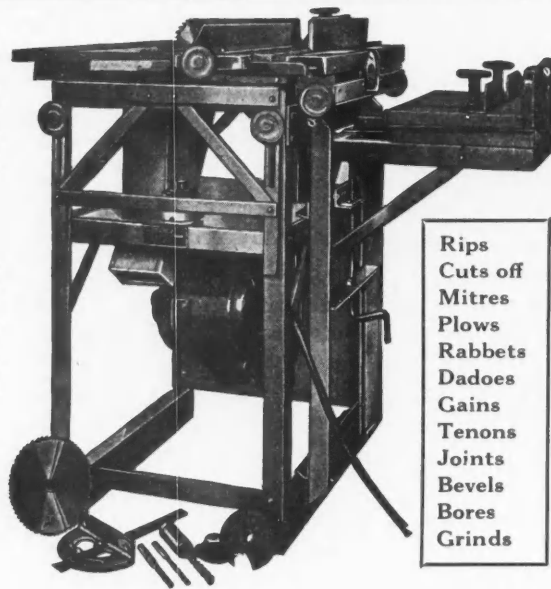

- Rips
- Cuts off
- Mitres
- Plows
- Rabbets
- Dadoes
- Gains
- Tenons
- Joints
- Bevels
- Bores
- Grinds

*Mail This Coupon*  
**PAXSON COMPANY, Dowagiac, Michigan**  
 Please send catalog to

Name .....

Street and Number .....

City ..... State .....

**PORTABLE and POWERFUL**  
On the Job or in the Shop

The **BEARCAT** Will  
INCREASE YOUR PROFITS

**THE PAXSON COMPANY**  
Dowagiac, Michigan



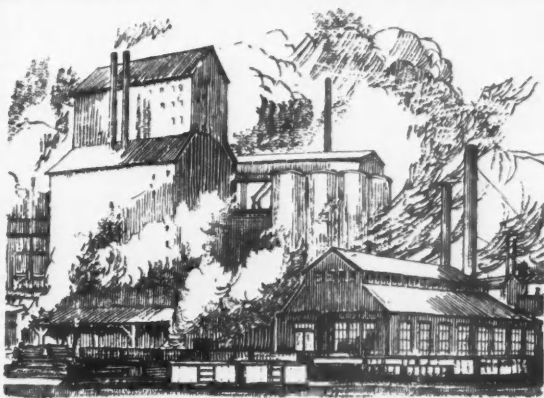

For all exposed uses such as roofing and siding Inland Copper Alloy Steel Sheets should be used

## Steel that's Durable All the Way Through

IT ISN'T necessary to rely solely on the coating of steel for protection against rust and corrosion. You can use Inland Copper Alloy Steel. When the coating or paint is gone from an Inland Copper Alloy Steel Sheet the fight against corrosion does not stop. These sheets are *durable all the way through*.

Inland Copper Alloy Sheets last two to three times as long as ordinary sheets—a statement amply proved by tests and usage. The copper which has been added to the molten steel gives to the finished alloy a quality of remarkable endurance.

You can safely recommend these sheets for exposed uses. They do not disappoint. Their cost is but little more than that of ordinary steel sheets. Write for descriptive circular.

# INLAND COPPER ALLOY STEEL SHEETS

INLAND STEEL COMPANY

38 South Dearborn Street, Chicago

Branch Offices: Milwaukee  
St. Paul, St. Louis  
Kansas City, Mo.

Mills: Indiana Harbor, Ind.  
Chicago Heights, Ill.  
Milwaukee, Wis.



*Simplex*  
REG. U.S. PAT. OFF.

Levels

TEN  
DAYS'  
FREE  
TRIAL



\$90<sup>00</sup>

AGENTS  
Wanted

## No Money Down

When you go shopping for instruments, clothing or anything else, would you make a deposit at the door for the privilege of inspecting the merchant's wares? Most emphatically NO!—so we feel since we cannot provide the convenience of display rooms in all sections of the country, that you are nevertheless entitled to free inspection before purchasing. Simply sign and mail the coupon and the complete details of our free trial offer, descriptive literature, etc., will come to you in the first mail.

Simplex Levels are made in three types—Convertible, Dumpy and Farm or Carpenter's Level. They are built under the direction of our own engineers and are fully guaranteed as to accuracy, workmanship, etc.

We refrain from extolling all the merits of the Simplex Line, we'd much rather that—

### YOU BE THE JUDGE

Mail the coupon now—remember you cannot lose on this transaction.

New York Blue Print Paper Co.

102 Reade Street  New York City

New York Blue Print Paper Co.

Gentlemen: Please send me full particulars regarding your free trial—No Money Down offer—also complete descriptive literature covering the Simplex Line.

Name .....

Street .....

City .....

# POWERFUL

As a Giant  
LOCOMOTIVE!

The Ideal Products Plant Mixer is a marvel of power—it runs as easily as the mammoth locomotive glides over the rails. It is easy to dump—is always ready for use. The “biggest thing” of its kind on earth!

Today—Investigate the Ideal Products Plant Mixer.

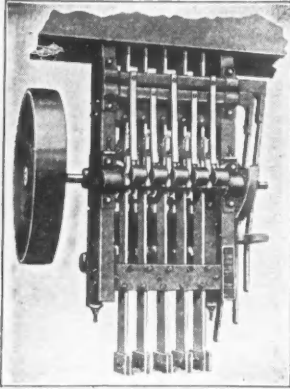

Why Tamp  
by Hand?



Hand tamping is as out of date as candle light, now that maximum results at minimum costs are available in the

### Ideal “Fit-All” Tamper

Operates over any machine, face-down or stripper, two or three core, regardless of make.

Write today for literature.

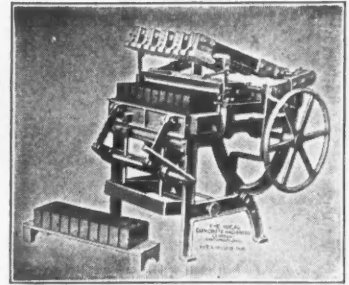

The Ideal Face-Up Brick Machine—makes plain or faced brick of quality in quantities. Circular ready for you—write for it.

# IDEAL

THE IDEAL CONCRETE MACHINERY CO.  
5014 SPRING GROVE AVE. CINCINNATI, OHIO  
TRADE MARK REG. U.S. PAT. OFF.

## As Many Profit Opportunities For You

### As There Are New Buildings Going Up and Old Ones Being Remodeled

You can lay Everlasbestos over old floors or use it for new work. Every new structure being erected—every old home or building of any kind to be remodeled—offers you a money-making opportunity. And that is why laying Everlasbestos is an all-year-round proposition.

Office buildings, churches, schools and public buildings are only a few of the big flooring jobs for which Everlasbestos is used. They mean big contracts and large profits for you if you go after them.

#### Attractive—Everlasting

Its fine texture and smooth, soft sheen make Everlasbestos most attractive. Its toughness and elasticity insure it against wear—this flooring is everlasting. Its superior ingredients and perfected formula insure every floor a perfect job. Everlasbestos makes satisfied customers who will send you more business.



Our illustrated Manual of Instructions makes Everlasbestos laying easy, being simple and complete.

Send now for free sample and all details of our interesting and most profitable proposition.

Everlasbestos Flooring Co.  
Dept B 95 North St., Rochester, N. Y.

# Everlasbestos Flooring

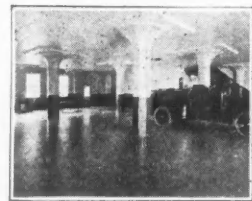

Everlasbestos Floor in Firehouse



Everlasbestos Floor in Drug Store



Everlasbestos Floor in Factory Lunch Room

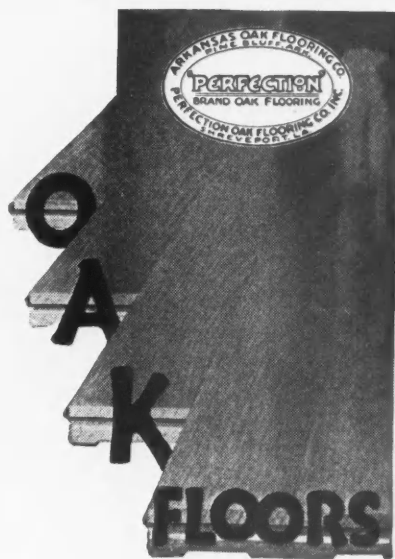

## New Sales Helps For Oak Flooring

One of the most attractively illustrated booklets on oak flooring is now ready for distribution among prospective homebuilders.

It tells the whole story of Perfection Brand Oak Flooring. You will find it of immense help in making sales.

We also have some very successful envelope stuffers for general distribution that we are supplying free.

Write today for these selling helps and full information about Perfection Brand Oak Flooring.

**ARKANSAS OAK FLOORING COMPANY**  
Pine Bluff, Arkansas

**PERFECTION**  
BRAND OAK FLOORING

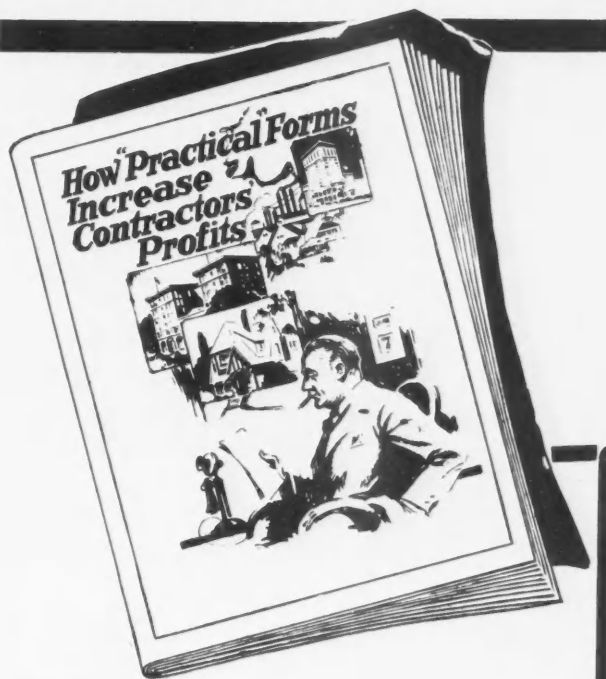

## Here's Your Copy--Free!

**It's Just Packed with Vital Information on Contractors' Records and Accounting Systems**

How do you keep your books? Are they accurate and complete or just based on guess-work and uncertainty? Don't let haphazard records bite into your profits. This new book points the way to greater profits through better accounting. Have you received your copy?

**This New 64-Page Book is Full of Time-Saving, Profitable Ideas**

An invaluable book of over 5000 words, containing more than 100 illustrations, for the large or small contractor who desires a simple, yet complete bookkeeping system. It illustrates and describes in detail, labor and material reports, payroll forms, time cards, extra work forms, proposals and contracts, contract and sub-contract forms, estimate sheets, order blanks, etc.

**Send for Your Copy While the Supply Lasts**

In this day of increasing competition and decreasing profit you cannot afford to be without it. Cut losses, save time and eliminate worry! You owe it to yourself and business. Don't wait—it's yours for the asking. Clip the handy coupon and send it now.

### MAIL THIS COUPON

(AB 3-25)

Frank R. Walker Co., 536 E. Lake Shore Drive, Chicago

Please send me Your New 64-Page Book FREE, entitled "How Practical Forms Increase Contractors' Profits."

Firm Name.....Business.....

Address.....

.....



## "THE Best glass" is absolutely flat~

"THE Best glass" is perfectly flat, and has no reverse curves. It is preferred by glaziers because it fits easily into the window frames. It is of uniform thickness and comes packed in clean well-built packages.

"The Best glass" is scientifically produced from laboratory to final packing. It undergoes two annealing processes, and is stronger by actual test than any other brand of glass.

"The Best glass" is graded to the highest accepted standards. The chemical composition of this product, while preserving its easy cutting qualities, makes it less liable to fading or breakage.

"The Best glass" is the choice of leading architects and discriminating builders everywhere. Through the scientific handling of materials, improved working machinery, and a rigid standard of quality, "the Best glass" has maintained its leadership for a quarter of a century.

*Ask for "the Best glass" by name,  
and see that you get the genuine.*

**AMERICAN  
WINDOW GLASS CO.**  
GENERAL OFFICES--PITTSBURGH, PA.  
*Branches in Principal Cities*



**T**WO thoroughbreds! That's what they are—made for the craftsman that buys the best, when he adds a tool to his chest.

You'll want to buy a V & B Vanadium hammer. They are made from special V & B formula vanadium steel, and handled with the finest hand-shaved, second growth white hickory. Octagon necked, and round faced—with a special non-slip claw, that firmly grips either a brad or a spike. A Vaughan's Expansion Wedge firmly locks the handle tight—is positive insurance of a tight head.

You'll want, too, V & B Unbreakable Planes. They are drop forged—not cast—from a solid bar of V & B supersteel. Stand the falls that would break an ordinary plane. Furnished with all vanadium steel blades and walnut handles, in the sizes you will want.

Two tools of particular merit—get them for your kit!

**VAUGHAN & BUSHNELL  
MANUFACTURING COMPANY**  
*Makers of Fine Tools*  
2114 Carroll Ave ~ Chicago, Ill. U.S.A.

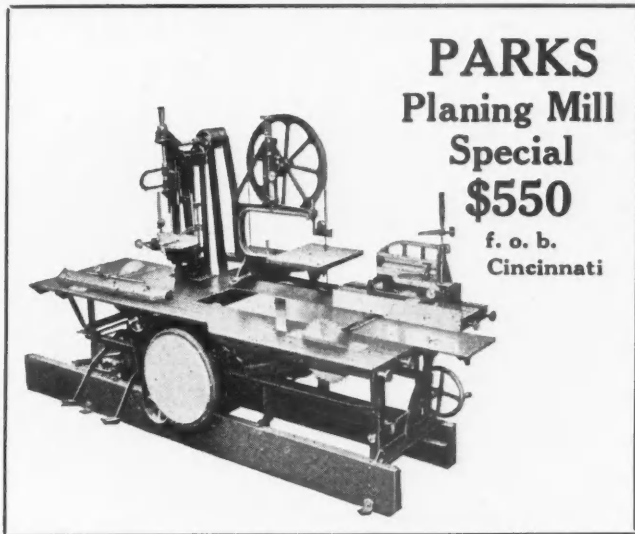

**PARKS**  
Planing Mill  
Special  
**\$550**  
f. o. b.  
Cincinnati

**This Parks and \$9.60  
built a paying business**

**T**HIS is the famous Parks Planing Mill Special—a woodworking machine known by carpenters and cabinet-makers from coast to coast.

It does everything in woodworking. It saves hard work. It saves wages. It saves time, and time is money.

We have hundreds of letters from successful men who started in business with a Parks—who owe their start to Parks quality, durability and fair prices.

But the most interesting story of success we ever received was from a young man in New Orleans, named Wright, who went into the screen business with a Parks and \$9.60 working capital and made good in a big way.



We have told his story in a little booklet, "How One Man Did It." If you own a shop or are planning to start a shop, you'll want to read it.

Send for this booklet "How One Man Did It." It's mighty interesting and it's free for the asking. We'll also send the Parks complete catalog.

**The Parks Ball Bearing Machine Co.**  
Fergus Street and C. H. & D. R. R. Cincinnati, O.  
Canadian Factory: 200 Notre Dame East, Montreal, Can.



**Fleck  
Fixtures**

**Builders of Homes--**

Our engineering staff is at your disposal. Let us help you plan the plumbing and fixtures for that home or homes you are building. We will gladly furnish you with an estimate of materials needed and quote you prices.

Our complete stock of goods will enable you to buy the best plumbing goods at reasonable prices.

The quality of every **FLECK** fixture is absolutely guaranteed.

Or individual attention will be given to your plumbing needs. Write us today

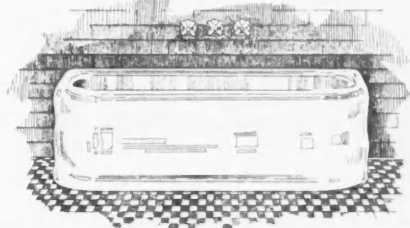

"PIER" TUB

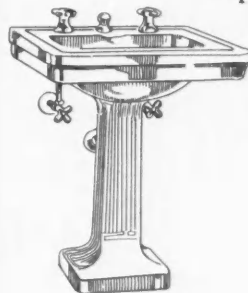

"SEMINOLE" LAVATORY

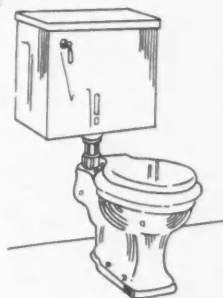

"SEMINOLE" CLOSET

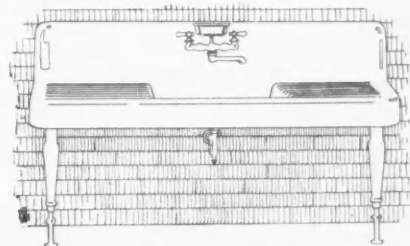

"PAWNEE" KITCHEN SINK

**FLECK BROS. Co.**

Main Office and Show Room  
50 N. 5th Street Philadelphia, Pa.  
Offices and Showrooms at  
Fleck-Marshall Co., Lancaster, Pa.  
Reading Fdry. & Sup. Co., Reading, Pa.  
Southern Supply Co., Baltimore, Md.  
Fleck Bros. Co., Lansdowne, Pa.  
Fleck Bros. Co., Camden, N. J.





PRICE \$75.00

### "LOXO" Compound Level for Builders, Contractors and Architects

Our patented clutch arrangement insures instantaneous action. Change can be made from levels to vertical angles without having to be lifted out of its wyes. Snaps in and out of position like a jack knife.

**Manufacturers of and Dealers in:**

Scientific Instruments      Drawing Materials  
Blue Print Papers          Artists' Supplies

Write for folder giving complete information.

**B. L. MAKEPEACE, Inc.**

Manufacturers

387 Washington St.

Boston, Mass.

## ELECTRICOAL GRATES



### Direct from the Manufacturer

All the sparkle and ruddy glow of a hard coal fire is obtained from a Pioneer Electricoal Grate, with none of the disadvantages of the old fashioned dirty, smoky coal grate.

There is a model in four artistic finishes for every fireplace.

Shipped direct from the factory to you at from—

**\$9.00 up to \$30.00**

Inquire for descriptive catalogue and prices

**PIONEER FIREPLACE & SUPPLY CO.**

Address nearest branch office

5327 W. Lake St., Chicago, Ill.  
1040 21st St., Detroit, Mich.

12 Calverton Rd., Baltimore, Md.  
240 Plummer St., Hammond, Ind.

# Do You Ever Figure on Skylights?

When you can figure on the entire roof and skylights you are in better position to close the whole job. When you can offer the owner a better skylight than your competitor you eliminate cut prices by better quality. When you select any of the 3-Way Skylight Constructions you have behind you a factory of international reputation.

## 3-Way Ventilating Skylights—

Gives full measure of perfectly controlled ventilation without losing any of the daylighting value. Made of heavy 18-gauge galvanized sheet steel frames carried on rigid steel trusses. Either ridge vent or full vent. Perfect installation for garages, laundries, shops, etc.

## STEEL LEAD Construction—

The everlasting metal construction. Has the strength of steel "T" bars with the permanence of lead. No putty, no packing, no painting.

## 3-Way Armored Wired Glass—

A concrete construction that is preferred for fireproof buildings. Made in factory finished slabs, ready to set. Glass is standard 1/2-inch thick wired glass set in metal shields which are embedded in the concrete. Permanent, easy to install, no upkeep.

*If you are interested in Better Skylights write  
for the Bulletins on Skylight Constructions*

**American 3 Way-Luxfer Prism Co.**

1307 S. 55th St., CICERO, ILL.

358-368 Webster Ave., LONG ISLAND CITY, N. Y.





Redwood entrance—124 Santa Clara Ave., San Francisco. Morron and Garren Architects

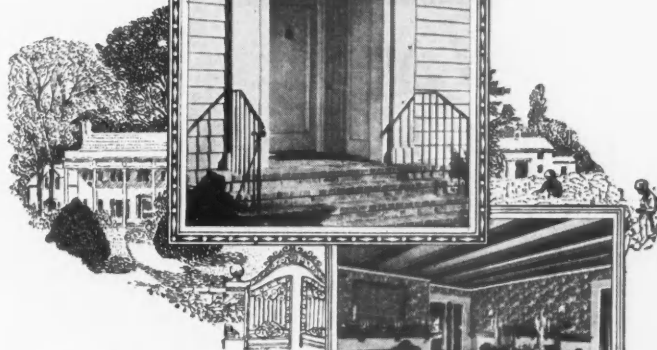

Dining Room—Redwood mahogany-stained beams, Redwood painted trim. Residence in Montecito, Santa Barbara, Cal. Russell Ray, Architect Chicago and Santa Barbara

for beautiful exteriors and interiors—REDWOOD

REDWOOD makes and keeps exteriors beautiful because it does not warp, shrink or swell—because it is permeated during growth with a natural preservative which protects it against fungus decay—because its uniform texture and freedom from pitch enable it to take and hold paint well.

For interiors Redwood's rose-pink to reddish brown color, its immense variety of grain patterns and the satisfactory effects obtained with wax, stains and paint make it most desirable. It can be obtained in extra wide boards for special, one-piece panels.

Because it resists rot, Redwood should be used wherever wood is exposed to the weather or to soil moisture—for shingles, siding and clapboards, foundation timbers, mudsills, door and window frames, mouldings, porch columns and exterior trim, cornices, railings and balusters, summer houses, garden furniture, pergolas and greenhouse construction.



Music Room—All Redwood finish, stained to rich rose-brown tone and finished in dull wax. Residence in Montecito, Santa Barbara, Cal. Russell Ray, Architect Chicago and Santa Barbara

To builders and architects we will gladly send a digest of "Technical Note No. 173" issued by the U. S. Forest Products Laboratory which assigns to Redwood the highest total rating for durability, strength as a beam or post, lack of shrinkage, ease of glueing, workability and ability to "stay put". Write for it and for our "Construction Digest".



CHICAGO 3066 McCormick Bldg. 332 So. Michigan Ave. NEW YORK CITY 933 Pershing Square Bldg. 100 East 42nd St. SAN FRANCISCO Robert Dollar Bldg. 311 California St.

THE LARGEST MANUFACTURERS AND DISTRIBUTORS OF CALIFORNIA REDWOOD

EVERY BUILDER SHOULD HAVE THIS BOOK

"Estimating Building Costs, Specification and Contract Writing"



Price only \$3.00 344 PAGES

ONE of the best books of its kind ever printed. Written by experts. Used in the classrooms at well-known universities and technical schools. A pocket encyclopaedia that will save you

many times its small cost. Contains many of the lesson papers prepared and used by the International Correspondence Schools. Note this partial list of contents:

Specification Writing: Principles of Specification Writing; Divisions of Specification; How to Write Specifications; Subject Matter of Specifications; General Conditions; Example of a Specification for a Residence. Specification-writing Memoranda: Building Erection, Construction and Equipment; Excavation and Masonry Work; Terra-Cotta, Faience and Slate Work; Carpenter Work; Painting; Hardware; Structural Ironwork; Ornamental Metal Work; Sheet-metal Work; Plumbing; Hot-air Heating; Ventilation; Electric Wiring. Estimating and Calculating Quantities: Principles of Estimating; Approximate Estimating; Outline of the Work; Accurate Estimating Schedule; Excavation; Concrete Work; Masonry; Brickwork; Carpentry; Roofing; Plastering; Joinery; Structural Steel; Heating and Ventilating System; Plumbing and Gas-fitting; Painting and Papering; Glazing; Example in Estimating; Excavation; Stonework and Brickwork; Ventilating Systems; Plumbing; Carpentry; Roofing; Lathing and Plastering; Joinery; Hardware; Heating; Gas-fitting; Wiring; Painting; Summary of Cost of Building. Contracts: Building Contracts; Character of the Agreement; Carrying Out the Agreement; Abandonment of Contract; Fraudulent Contracts; Completion of the Contract; Penalties and Premiums; Extra Work; Responsibility and Risk; Legal Meaning of Words; Forms of Contract.

Never before has so much practical information been gathered together in one book. It's a book you cannot afford to be without and, at the price, a real bargain for readers of the "American Builder."

Just tear and mail the coupon with \$3.00, and a copy of "Estimating Building Costs, Specification and Contract Writing" will be sent to you by return mail. You run no risk. Money back if not satisfied.

TEAR OUT HERE

INTERNATIONAL CORRESPONDENCE SCHOOLS Box 8135-C, Scranton, Penna.

I enclose \$3.00. Please send me—post-paid—your 344-page book, "Estimating Building Costs, Specification and Contract Writing." It is understood that if I am not entirely satisfied I may return this book within five days and you will refund my money.

Name.....

Address.....

City..... State.....

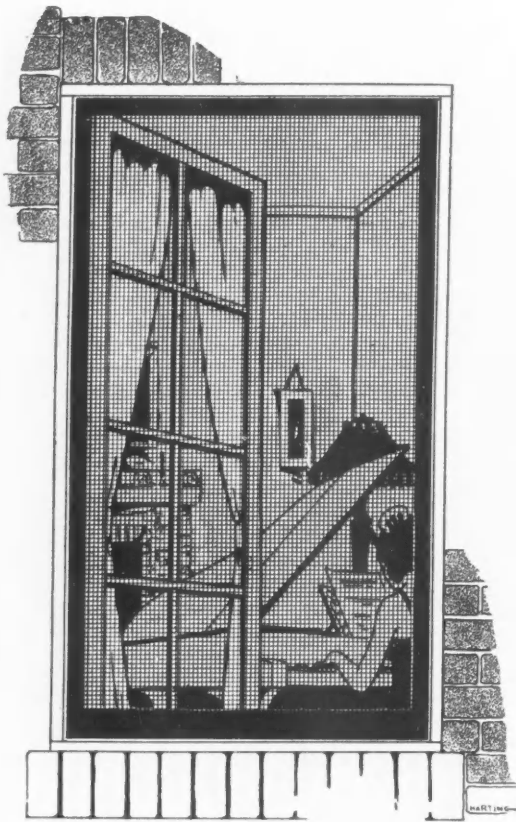

## The Difficulty

in making Inswinging Casements tight at the sill is eliminated by using

# WASS Inswinging Casement Window Hardware

(Patented)

Necessitates very little mill-work. Easy and inexpensive to install. Locks and seals the sill in one operation.

Furnished in any finish desired and for any width and thickness of sash at one and the same price.

Write for price and catalog (A. I. A. 27C2, especially designed for the convenience of Architects and Contractors).

## Casement Window Equipment Co.

120 South 9th Street

Minneapolis, Minnesota

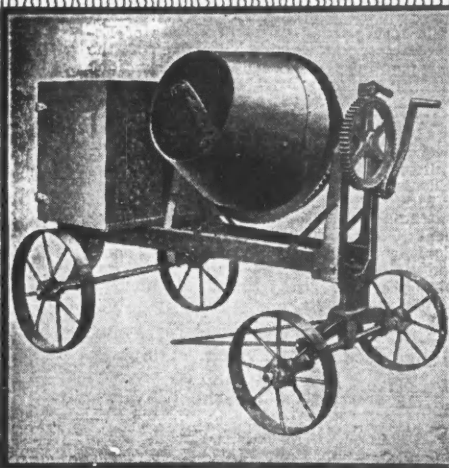

**STEWART  
CONCRETE  
MIXERS**

**E**XACTLY the right mixer for your own requirements—at the price you want to pay. That's what the STEWART line of 20 models and five sizes enables you to select. And whichever one you choose will unfailingly deliver uninterrupted, economical, trouble-free service.

Complete stocks in most principal cities. Write today for complete descriptions and prices.

**Stewart Manufacturing Co.**  
157 Rath Street, Waterloo, Iowa

Write  
for  
Prices

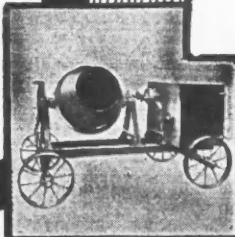

**SOLD  
ON  
THE  
SQUARE**

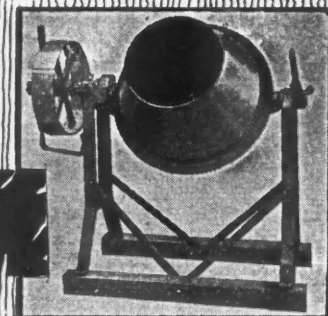

**BUILT  
ON  
THE  
SQUARE**



Be sure the casements on your jobs are equipped to keep him out



It means contented clients . . . from whom your new clients come

To make those casements as practical as beautiful, build them out-swung with inside screens—and Win-dor Casement Operators inside the screen.

The screen need not be opened to swing the window. A simple turn of the handle inside the screen swings the window quickly and easily to any position desired. Then it automatically locks; fast and snug till swung again, when it automatically unlocks as it starts swinging.

Win-Dor Casement Operators add the final touch of convenience to casements. They can be put on old casements as easily as on new. Insect exclusion is but one of a dozen comforts with which it endows them, and every comfort and convenience is appreciated by your clients—upon whose recommendations your progress depends. A style for every purse or preference. Write for Catalog No. 10—especially prepared for Architects. And—"See them in Sweet's."

**The Casement Hardware Co.**  
231 PELOUZE BUILDING, CHICAGO

**Win-Dor**  
CASEMENT  
OPERATORS



The Handle fits in like this when you wish to swing the casement—or may be had attached to each operator if desired. Detached handles may be conveniently hung on window frame, out of sight behind draperies.

Steel Casements may now be easily equipped with improved Win-Dor Operators. Simply screw on to all standard Fenestra Casements. For other makes, specify in steel sash contract to provide necessary attachments. For all metal casements follow our standard details for sash.



## The finishing touch to Bathroom Beauty



FIXTURES built in the walls have become so popular that in a few years they have almost completely replaced portable or attached fixtures in all new work.

Fairfacts Fixtures have been widely imitated and many of these imitations are of extremely poor quality. The Fairfacts Certificate which is pasted on Fairfacts Fixtures is a definite guarantee from a responsible manufacturer that the Fixture will retain its original snow-white beauty and remain free from cracks or stains as long as the building stands.

It is a costly and difficult process to replace fixtures that become defective. That is why the Fairfacts Guarantee is especially important both to architects and to their clients in assuring a bathroom of lasting beauty.

The design of Fairfacts Fixtures has a simple motif which makes them harmonize with each other. Their snow-white color also makes a perfect blend with any color scheme or tint of walls.

Fairfacts Fixtures may be installed in walls of Tile, Plaster or Keene Cement. They are carried in stock by tile contractors who also install them.

Our new Catalog F is now ready. Write us for your copy.

THE FAIRFACTS COMPANY, INC.  
Manufacturers  
Dept. KI. 234-236 West 14th Street,  
New York City.

SPECIAL  PROCESS

# Fairfacts Fixtures

THE FAIRFACTS COMPANY, INC.  
Dept. KI. 234-236 West 14th Street, New York.

Please send me your new catalogue for my files.

Name.....

Address.....



# White's Improved New "Duplex" Level

Here is a newly patented combination Level-Transit, priced at \$35.00 designed for carpenters, mill wrights, and building trade mechanics. A simple, accessible lever makes the change from Level to Transit instantly. (See illustration.) No lifting of telescope out of Wyes. No jolting when making change. No clamps or screws to loosen or tighten. 10 diameter lens system.

## 5 New Features

- (1) Index on Telescope insuring instant release from return to "level" position.
- (2) Three-Point Bearing on Vertical Axis with spring tension, insuring constant and perfect contact of bearing surfaces.
- (3) Adjustable Telescope Standards, cast integral.
- (4) Three-Point Bearing on Horizontal Circle with center spring action, insuring constant and perfect contact of horizontal bearing surfaces.
- (5) Protective Flange under circle preventing "gumming up" or gathering of dust.



Price  
**\$35.00**

"Duplex" in position for running lines and plumbing uprights.

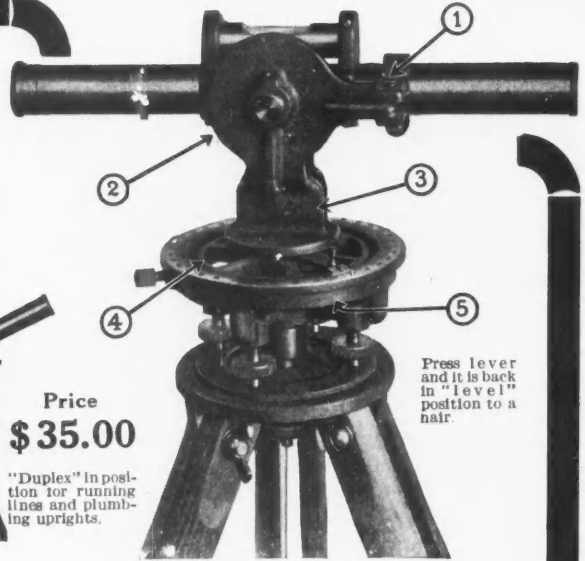

Press lever and it is back in "level" position to a hair.

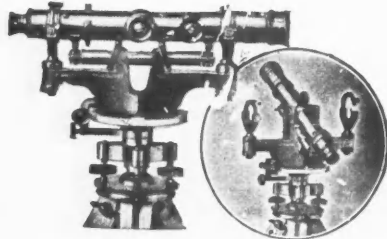

White's Convertible Level

## White's Improved Convertible LEVEL

For General Contractors

This instrument has been used for years by leading builders, architects and contractors. It can be changed from level to transit in 10 seconds. Level bars and transit bars are cast as one, eliminating inaccuracies. No loose parts, nothing to go wrong. Shifting base permits instrument to be set over center of stake without resetting tripod. 25 diameter lens system. It is perfect in every detail—simple and sturdy.

**DAVID WHITE CO., INC.**  
901 Chestnut St., Milwaukee, Wis.

**10 DAYS  
FREE TRIAL**

White Improved Levels must sell themselves; to you, or you need not keep them. Let us send you a New Duplex, or a White's convertible to use on your next job. No obligation. Write for particulars.

# Are you familiar with this type of window

Made possible by Carrier's Quadrant Adjuster. For use in public buildings, schools, hospitals or residences where maximum ventilation, convenience and artistic effect are desirable.

Advantageous features of this type of window are—

- |   |   |
|---|---|
| 1—Not necessary to move screens to open or close windows. | 4—Eliminates any possibility of rattling or sagging.        |
| 2—Window is automatically locked in any position.         | 5—Both sides of window easily cleaned from within the room. |
| 3—There are no fasteners or hinges required.              | 6—Quickly and easily installed at a low cost.               |

Write for our Architectural Leaflet which contains detailed drawings and specifications

Sweets and Architects' Samples  
Corporations, New York



**CARRIER ADJUSTER COMPANY**

Casement Window Hardware

Jacksonville, Fla.



Looking in—Easily installed on any stock casement sash—Simple in design. Made of rust proof bronze.

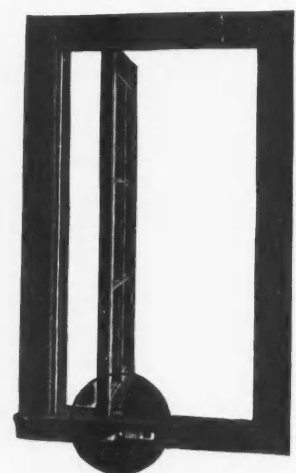

Looking out—Operated by worm gear, turned by a small control lever. Cannot stick.

# Salesmen! Step Ahead!

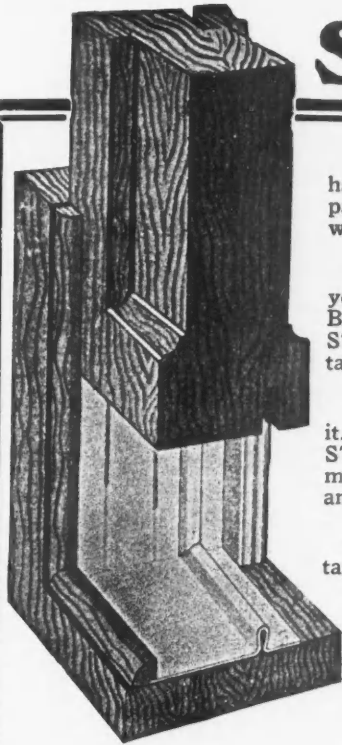

## Burrowes Metal Weatherstrips

have offered many salesmen the way to a greater income. You can leave the beaten path and take the short-cut to more money by taking the agency for this finest of all weatherstrips.

### Exclusive Territory

There is exclusive territory available to you in sections of the country where BURROWES METAL WEATHERSTRIPS will sell at sight. Their many talking points will help you.

### Superior Product

You don't have to take our word for it. BURROWES METAL WEATHERSTRIPS carry the enthusiastic endorsement of many of the leading architects and contractors.

### Beat Competition

This fact, combined with the advantages apparent when you show them, enables you to outstrip competition everywhere.

### Every House Needs Them

With present high prices of coal, every householder will be a good prospect. Comfort as well as economy is a consideration.

### Good Profits

Our long experience and excellent financial standing enable us to offer you most attractive profits. Our plant is strictly modern throughout, and production costs are low.

### Financial Responsibility

Remember that when you are a Burrowes representative, you can be proud of your connection, and sure your orders will be filled promptly and reliably.

## Now is the Time for You to Act!

This is the ideal time for you to become a Burrowes agent. Early winter coal bills have already given cruel shocks to most householders. They will listen eagerly when you tell them of a way to cut down that fuel consumption. Get into the field and start cashing in on the reputation and quality of BURROWES METAL WEATHERSTRIPS!

# BURROWES WEATHERSTRIP CO.

2161 No. California Ave.

Specify Territory Desired

Chicago, Ill.

## Every Builder Can Afford One!

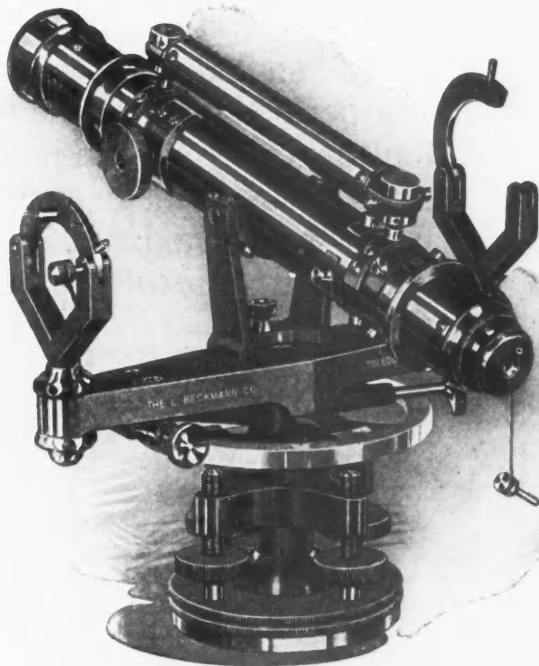

No. 406

Architects' Convertible Level

When you buy a light-weight motor truck you're lucky if it hangs together after three years. But when you purchase a Beckmann instrument you have a *permanent* investment.

Actual tests show that this instrument saves \$2.00 a day every day it is used. If you use it only once a week, it pays for itself in less than one year,—then keeps right on saving you \$100 or more every year for 10 to 20 years longer!

Just this one instrument for all jobs,—interior or exterior work. Lay out angles, level walls, floors and foundations, align shafting, prolong vertical lines, etc.,—or use it for excavating, grading, ditching, and so on.

Very simple to operate, and can be given a 10-day trial at our risk. Just mail the coupon.

The L. Beckmann  
Company  
500 Adams street  
TOLEDO  
OHIO

TEAR OFF HERE—SIGN AND MAIL TODAY AC-8

The L. Beckmann Co., Toledo, O.  
Gentlemen—Send latest catalog and details of your free trial offer.

Name \_\_\_\_\_  
Street \_\_\_\_\_  
City \_\_\_\_\_  
State \_\_\_\_\_

Cash  
in  
on  
this  
new  
source  
of  
extra  
profit

No. 30-A. Listed as  
**Standard**  
by the Underwriters'  
Laboratories, Inc.

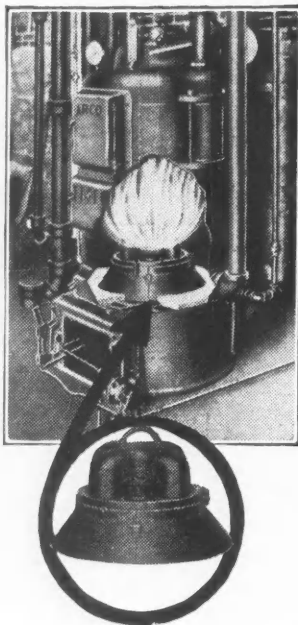

Now you can equip your homes with oil burners at a moderate price—a source of extra profit! The new, improved Oliver Oil-Gas Burner places oil heat within the reach of all. Makes it easier to sell the homes you build. Home buyers want modern *oil* heat instead of coal. They want its wonderful convenience, but without a price penalty of \$500 or \$600 or more. The new Oliver, without electrical connections, noisy motor or moving parts, can be installed at an additional cost to the home buyer of less than half the price of the lowest priced power burners! Thermostatic or upstairs chain control. Intense heat, low heat, or any degree between. Glowing warmth in coldest weather. Now giving satisfaction in thousands of homes. Guaranteed to give efficient heating service. Specifications for specific installations supplied without charge by our Heating and Plan Department. Write for details of special builder's plan.

**OLIVER OIL BURNER CORPORATION**

346 Oliver Bldg., St. Louis, Mo.

*Oldest and Largest Manufacturers of Oil-Gas Burners in the World.*

**OLIVER  
OIL-GAS BURNER**

*(The hardest hardwoods grow in the North)*

## STEADILY INCREASING SATISFACTION

the longer the owner lives,  
is so sure an outcome with

# *Beautiful* birch

that both the builder and artisan do themselves a favor, as well as their customer, when boosting that sterling hardwood for doors, floors and standing trim in homes of every type. This applies equally to all apartments and public buildings.

**birch** from the virgin forests of Northern Michigan and Wisconsin is "the most behavingest" hardwood in the American market today. It is easily handled and stands up so perfectly after installation that every job is a perpetual advertisement for every man who had a hand in it. *The owner's enthusiasm grows.*

*Write us your experiences and ask us particulars. We are here to help you in every way.*

**THE BIRCH MANUFACTURERS**

201 F. R. A. Building  
OSHKOSH, WISCONSIN



*(The hardest hardwoods grow in the North)*





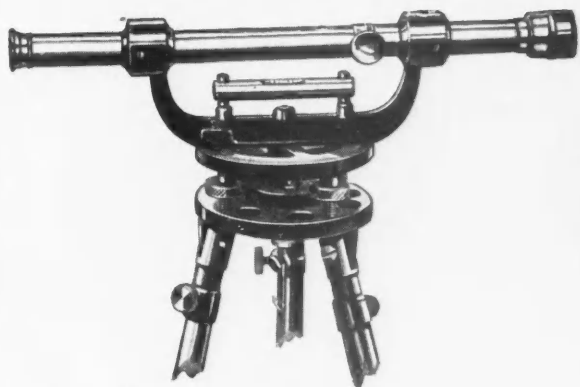

# Get this Level

No. 101 A — \$15.00

No. 101 C — \$25.00

**W**HICHEVER one you buy, after you've used it once you'll wonder how you got along without it.

For builders' and carpenters' use in leveling foundations, running ditches, etc., etc., they are without equal. Simple and easy to use.

No. 101 A—\$15.00—has 12 in. plain nicked sight tube, without lenses, small eye aperture and the usual cross wires.

No. 101 C—\$25.00—has 12 in. brass, nickel plated sight tube, telescope lenses making the instrument adjustable to distances, friction cap to protect lenses against dirt and breakage and the eye aperture is protected by a shutter.

Both instruments are complete with wood carrying case, long legs and level vial.

Ask your hardware dealer. Write us for copy of booklet on use of Transits and Levels. Also for free copy of Catalog No. 23-6.

## THE L. S. STARRETT CO.

*World's Greatest Toolmakers*  
Manufacturers of Hacksaws Unexcelled  
Steel Tapes—Standard for Accuracy

ATHOL, MASS.

# Starrett Tools

7745



## The only man who could talk to the Superintendent

"SOON after I began studying," a student wrote to us the other day, "we had a change in management at our plant. I certainly was glad then that I had decided to study in my spare time. For, thanks to my I. C. S. course, I was the only man in the organization who could talk to the Superintendent in his own language. As a result, I was promoted over men who had been here from ten to twenty years. My salary has been increased 90% in the last ten months."

**T**HAT'S a true story of what just one I. C. S. student has done. There are thousands of others. Every mail brings letters from men and women telling of promotions and increases in salary due directly to spare-time study.

One hour a day, spent with the I. C. S. in the quiet of your own home, will prepare you for success in the work you like best. *Yes, it will!* Put it up to us to prove it.

Mail this coupon to-day

TEAR OUT HERE

### INTERNATIONAL CORRESPONDENCE SCHOOLS

BOX 8136-C SCRANTON, PA.

Explain, without obligating me, how I can qualify for the position, or in the subject, before which I have marked an X:

- |  |  |
|--|--|
| <input type="checkbox"/> ARCHITECT                       | <input type="checkbox"/> Navigation                |
| <input type="checkbox"/> Architectural Draftsman         | <input type="checkbox"/> SALESMANSHIP              |
| <input type="checkbox"/> Reading Architects' Blue Prints | <input type="checkbox"/> ADVERTISING               |
| <input type="checkbox"/> Contractor and Builder          | <input type="checkbox"/> Window Trimmer            |
| <input type="checkbox"/> Building Foreman                | <input type="checkbox"/> Show Card, Sign Painting  |
| <input type="checkbox"/> Concrete Builder                | <input type="checkbox"/> BUSINESS MANAGEMENT       |
| <input type="checkbox"/> Structural Engineer             | <input type="checkbox"/> Private Secretary         |
| <input type="checkbox"/> Structural Draftsman            | <input type="checkbox"/> Business Correspondent    |
| <input type="checkbox"/> Plumber and Steam Fitter        | <input type="checkbox"/> BOOKKEEPER                |
| <input type="checkbox"/> Heating and Ventilation         | <input type="checkbox"/> Stenographer and Typist   |
| <input type="checkbox"/> Plumbing Inspector              | <input type="checkbox"/> Higher Accounting         |
| <input type="checkbox"/> Foreman Plumber                 | <input type="checkbox"/> COMMERCIAL LAW            |
| <input type="checkbox"/> Sheet Metal Worker              | <input type="checkbox"/> Common School Subjects    |
| <input type="checkbox"/> CIVIL ENGINEER                  | <input type="checkbox"/> Mathematics               |
| <input type="checkbox"/> Surveying and Mapping           | <input type="checkbox"/> GOOD ENGLISH              |
| <input type="checkbox"/> ELECTRICAL ENGINEER             | <input type="checkbox"/> ILLUSTRATING              |
| <input type="checkbox"/> Electric Lighting and Rys.      | <input type="checkbox"/> Railway Mail Clerk        |
| <input type="checkbox"/> Electric Wiring                 | <input type="checkbox"/> CIVIL SERVICE             |
| <input type="checkbox"/> Telegraph Engineer              | <input type="checkbox"/> Mining Engineer           |
| <input type="checkbox"/> Telephone Work                  | <input type="checkbox"/> METALLURGY                |
| <input type="checkbox"/> MECHANICAL ENGINEER             | <input type="checkbox"/> Gas Engine Operating      |
| <input type="checkbox"/> Mechanical Draftsman            | <input type="checkbox"/> Textile Overseer or Supt. |
| <input type="checkbox"/> Machine Shop Practice           | <input type="checkbox"/> TRAFFIC MANAGER           |
| <input type="checkbox"/> STATIONARY ENGINEER             | <input type="checkbox"/> AUTOMOBILES               |
| <input type="checkbox"/> CHEMIST                         | <input type="checkbox"/> AGRICULTURE               |
| <input type="checkbox"/> Pharmacy                        | <input type="checkbox"/> Poultry Raising           |
|  | <input type="checkbox"/> Spanish                   |
|  | <input type="checkbox"/> French                    |
|  | <input type="checkbox"/> RADIO                     |

Name \_\_\_\_\_  
 Present \_\_\_\_\_ Business \_\_\_\_\_  
 Occupation \_\_\_\_\_ Address \_\_\_\_\_ 3-6-24  
 Street \_\_\_\_\_  
 and No. \_\_\_\_\_  
 City \_\_\_\_\_ State \_\_\_\_\_

Canadians may send this coupon to International Correspondence Schools Canadian, Limited, Montreal, Canada.

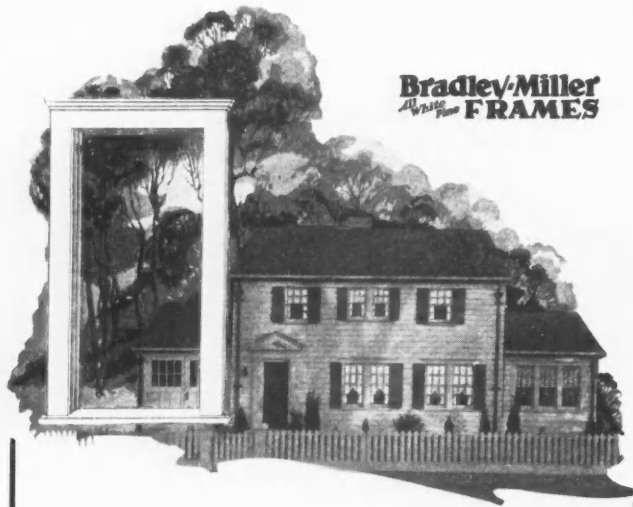

## CUT BUILDING COSTS!

Bradley-Miller Frames will do it because they come ready fitted to the opening. This saves time, labor and money. Any carpenter can assemble a Bradley-Miller Frame in seven to ten minutes. Low in price. Made of genuine white pine of a quality of workmanship calculated to make the Bradley-Miller Frames the very best. Unaffected by climatic conditions.

We make frames of all sizes to fit any standard opening for brick, frame or stucco buildings. Their handsome appearance and sturdy construction are a lasting source of satisfaction to the home owner.

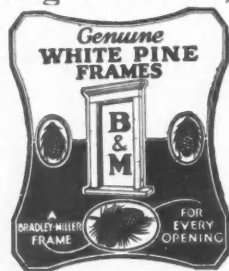

*This Label Your Protection*

*Write for Further Information*

## BRADLEY-MILLER & CO.

BAY CITY, MICHIGAN

Eastern Frame Representative: A. D. MOORE  
P. O. Box 867, New Haven, Connecticut

Ohio Frame Representative: H. G. VINCENT  
Garrettsville, Ohio

## "Steelcrete" Metal Laths

For  
Every  
Building  
Planned

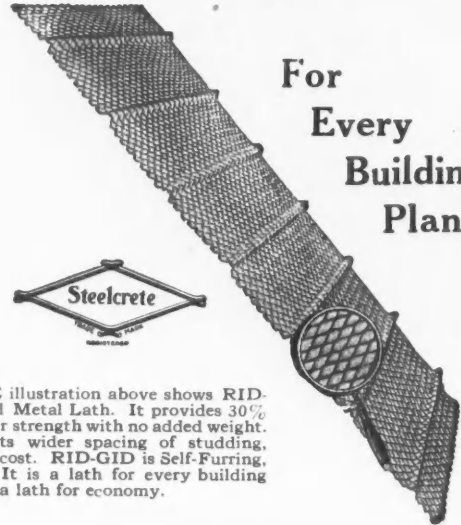

THE illustration above shows RID-Gid Metal Lath. It provides 30% greater strength with no added weight. Permits wider spacing of studding, saves cost. RID-GID is Self-Furring, too. It is a lath for every building need, a lath for economy.

### *Build for Safety, Durability, Economy*

**B**UILDERS everywhere today recognize the advantages of Metal Lath for every structure they erect. From tiny bungalow to giant skyscraper there is greater safety, permanence and ultimate economy for the owner when the lath is of metal.

And when you choose from the "Steelcrete" line you find a Metal Lath well suited to each particular job.

RID-GID Metal Lath with its strength and economy; Steelcrete Rib Lath as a time and a labor saver; "Steelcrete" Metal Lath, the standard diamond mesh; Galvanized Lath cut from galvanized sheets; Copal Lath of copper bearing rust-resisting metal; Post Office Lath made to the government specifications for post offices. For every building planned there is a lath in the "Steelcrete" line to make it a better structure.

Carried in stock by leading dealers in Building Supplies

Send for the "Steelcrete Products" booklet giving weights and sizes; also ask for bulletins on "Steelcrete" Rib Lath, and Copal or RID-GID Metal Laths.

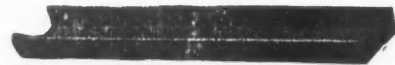

"Steelcrete" Channels and Corner Beads  
Accessories needed in all fireproof construction.

## The Consolidated Expanded Metal Companies

BRADDOCK, PA.

Philadelphia: 1075 Germantown Ave.  
Chicago: 1234 W. Washington Blvd.  
Pittsburgh: Oliver Bldg.

New York: 103 Park Ave.  
Cleveland: 450 Leader-News Bldg.  
Detroit: Majestic Bldg.  
Minneapolis: Builders' Exchange

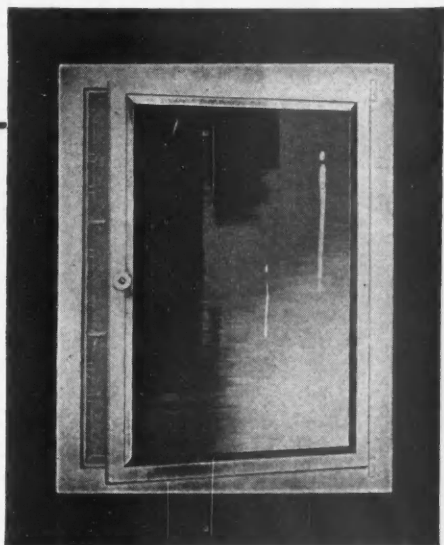

WHENEVER A "WHITE-STEEL" Medicine Cabinet, or product is specified by architect, contractor or builder the owner is assured of a permanent installation.

**"White-Steel" Sanitary Furniture Co.**  
GRAND RAPIDS, MICH.

Dept. 23



## Easy and Quick to Lay No Experience Necessary

One of the remarkable things about Wright Rubber Tile is, that because of its Patented Interlapping Flaps, *anyone* can lay it over wood or concrete floors. It stays flat, too, because the flaps so lock that the corners can't come up. Upkeep is eliminated. Made in wide range of flat tone and pleasing color combinations.

Here is a floor you can recommend to anyone wishing a quiet, sanitary, beautiful, restful floor. A Wright floor has never worn out yet. Easy to sell,—easy to lay. A great many contractors and builders are our agents.

*Write for particulars*

**WRIGHT RUBBER PRODUCTS CO.**

DEPT. A. B. 3

RACINE

WISCONSIN



## Economy and Utility in the Fain "Fold-Away" *Breakfast Room*

An efficient room that folds back into its cabinet, requiring no floor space when not in use. A rental feature to homes and apartments. Time, labor and expense saver—a necessity of today

## Fain Manufacturing Co.

*National Bank of Commerce Building*  
Norfolk Virginia

## And Now the Fain "Fold-Away" *Ironing Board*

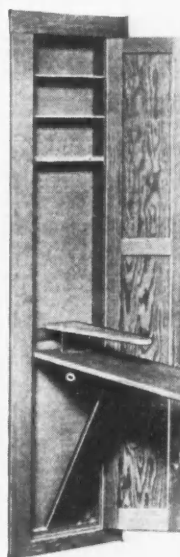

The Fain "FOLD-AWAY" Ironing Board is designed to meet the demand for a high quality cabinet at a reasonable price. The construction is strong, the folding arrangement simple and practical. Will not warp. Shipped complete, ready to install.

Same care in building as featured all "FOLD-AWAY" products.



# KITCHEN MAID

STANDARD KITCHEN UNITS

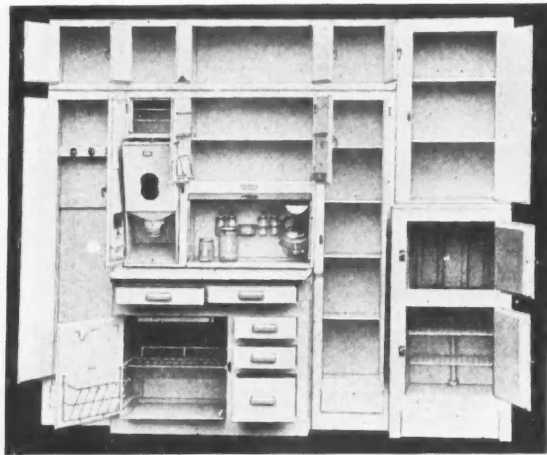

## A "flexible kitchen" brings you easier profits

Whether you build to sell, to rent, or on contract for others, Kitchen Maid Units help you profit by better kitchens. All women do not like the same kitchen arrangement. Group them or move them. Put them all against one wall or set them in corners. Each unit is complete in itself; can be set anywhere, or fits perfectly into groups. The cost is no more than old fashioned built-in cupboards; the cabinet work is real craftsmanship; the idea is everywhere recognized as modern, efficient and economical. Write for catalog, dimensional drawings and special prices for builders.

- WASMUTH-ENDICOTT CO.**  
1350 Snowden Street, Andrews, Indiana
- Please send me information regarding the units checked:
- PULMANOOK, consisting of table and 4 seats folding into wall. For alcove ( ) ; for any kitchen corner ( ) .
  - COMBINATION 210-X, with refrigerator, consisting of cabinet, broom closet, dish closet, and linen cupboards to set against wall.
  - IN-A-WALL IRONING BOARD, folding into wall when not in use.
  - BROOM CLOSET, to set in any kitchen ( ) ; to be built into wall ( ) .
  - DISH CLOSETS, LINEN CUPBOARDS, to be set in ( ) ; to be built in ( ) .
  - IN-A-WALL TELEPHONE SEAT.
  - KITCHEN MAID KITCHEN CABINET.
  - DIVIDED CUPBOARDS, to be used to separate breakfast room from kitchen.
  - REFRIGERATOR.

Name.....  
Address.....  
City..... State.....



See Telephone Directory in leading cities for branch offices and agents.

**Only \$3 DOWN**

**SILENT MODEL NO. 8**

**Honor Built L.C. SMITH**

for this Long Wearing BALL Bearing

WE will send you this wonderful typewriter with **absolutely no obligation** to you whatsoever. You **send no money**. When the machine arrives, you deposit only \$3 with your express agent and test this remarkable bargain thoroughly in your own home or office for **10 days**. If you are not satisfied it is the **greatest value** and the **finest typewriter** you ever saw, just tell the express agent and **he will hand back every cent to you**. If you keep it, your small monthly payments so small you'll never miss them—just like rent.

### LIFETIME CHANCE!

Our New Special prices are the **lowest ever made** on the world's famous, **BALL-BEARING Silent L. C. Smith**—late style models—up-to-date, **full size perfect machines**—every modern convenience—absolutely finest quality rebuilt and guaranteed for 5 years. No other typewriter at anywhere near our price will give as many years of perfect service. We are the **largest exclusive dealers in L. C. Smith Typewriters in the world**. The **easiest running and longest wearing** typewriter ever built. Over half a million sold. Easiest to operate and learn.

### FREE TO YOU NOW!

Complete Course of Lessons on Touch Typewriting; Operating and Instruction Book; Tools and Waterproof Cover—all free with each machine. Send for **Free Trial Plan: New Special Low Price Offer**; and **Booklet of Valuable Typewriter Information** before offer is withdrawn.

**SMITH TYPEWRITER SALES CORP., 310-360 E. Grand Ave., Chicago Ill.**



**You Can Build This Home As Easily as the Ordinary Kind and there are**

## 200 PLANS

in Keith's New 1925 Book, "Beautiful Homes," everyone of which will give you some good ideas. They are homes that will interest your customers because different and well planned. This wonderful book of 272 pages, full magazine size, containing many articles on the subject of home building

besides 200 carefully tested plans, will be mailed, together with entering a year's subscription to Keith's Magazine on home building, nationally known for 25 years, all for the price of subscription alone, \$3.00. If preferred, we will send C. O. D., you paying the postman but \$3.00 plus a few cents postage.

**KEITH CORPORATION, Architects**  
100 No. 7th Street Dept. 2-C MINNEAPOLIS, MINN.

# BARKER ANNOUNCES NEW MODELS IN Portable Electric Machines



## NEW MODEL E BARKER PORTABLE ELECTRIC SANDER

Greatly Improved—Sturdy—Durable  
Sands Smooth Rapidly

Gears (in oil) and  
Motor Dust-proof

Send for Bulletin E.

Designed for Durability, Speed and  
Accuracy on the Job

### New Barker-State Gear Drive Universal and Plain Saws.

Wide helical cut gears, ball bearing arbor all running in oil.  
Large cast table and sturdy pedestal.  
Operates from light or power circuit.

Most powerful portable saw made.

Send for Bulletin S

### Other BARKER-BETTER-BUILT

Machines are  
Band Saws,  
Jointers,  
Sanders,  
Shapers,  
Routers,  
Lathes,  
Floor Saws,  
Glue Pots,  
Combination  
Woodworkers.

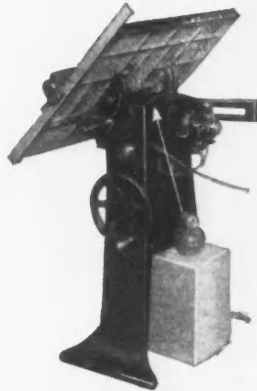

Rear View



UNIVERSAL SAW



R. L. **BARKER** & CO.  
642 W. Washington Blvd. CHICAGO

## A Year-Around, Profitable Business for You!

with the

## New Model Ideal Floor Sander

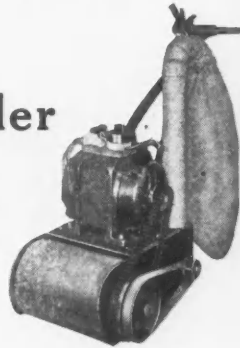

The floor sanding business offers you an excellent opportunity to establish a pleasant, well-paying business of your own. Don't work for the other fellow all your life! Be your own boss. Make real profits instead of mere wages!

### Five Days' Free Trial

We will send you the New Model Ideal Floor Sander for five days' trial. It will not cost you a penny and there is no obligation. When you actually operate it yourself, you will understand why it has won the universal approval of largest sanding contractors. We will show how you can go into the business and pay for your Ideal Sander out of your profits on our time-payment plan. Your future depends on your decision now. Don't wait. Write us today.

## BOETTCHER COMPANY

440 N. Peoria St.

Chicago, Ill.

# Concrete Reinforcing

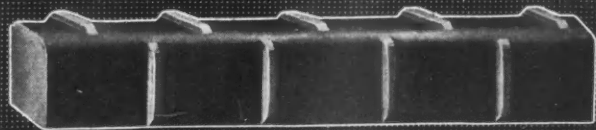

## Bars, Wire Mesh, Spirals, etc. Immediate Shipment

Whether your job requires ten pounds or ten tons, we can make immediate shipment from our stocks. We will ship plain material the same day your order is received; cutting, bending and making up spirals, etc., usually requires more than 24 hours. On your next job let us quote you complete prices that will mean big profits to you.

To make it easy for you to list bent bars, structurals and accessories, we have prepared a contractor's handy form which shows all standard types of bends, dimensions, etc. A tablet of these forms, in duplicate, will be mailed FREE to any contractor upon request. Mail the coupon and get some of these handy forms without obligation on your part.

## RYERSON

Chicago  
St. Louis  
Cincinnati  
Detroit  
Buffalo  
New York

Without further obligation on my part, please send me the items marked below:

Send Contractors' Handy Forms  
 Send Reinforcing Booklet

MAIL THIS  
COUPON  
TODAY  
11

# DOUBLE PROFITS



Pipe, Tile and Culvert Molds  
All Sizes  
\$16.00 up

There is **BIG** money in concrete work for the man with **UTILITY** equipment. Costs no more, but gives best results. Order direct or write headquarters for complete catalog and prices.

**Concrete Equipment Co.**  
500 Ottawa St.  
Holland, Michigan



Chimney and Porch Mold  
\$6.00



Flower Box Mold  
\$39.00



Vase Mold  
\$24.80



Porch Outfit Complete  
\$59.80



**UTILITY CONCRETE EQUIPMENT**



Utility Brick Machine  
\$69.90



\$15.00 Complete Block Outfit



\$68.00 Complete Block Making Outfit

## IT'S WARM INSIDE DON'T WORK OUTSIDE

### Floor Surfacing with an Electric Rotary Machine

is a big paying business and will keep you busy the winter months. You can make \$20.00 to \$50.00 a day.

The Electric Rotary is easy to handle, efficient and economical in operation and can be used for many different kinds of work. It sandpapers, refinishes old wood floors, surfaces and polishes marble, terrazzo, cement, etc. Has no equal for scrubbing as well as waxing and polishing.

**\$50 STARTS YOU NOW**

Take advantage of our easy payment plan and get started at once. You can pay for the machine while you are using it.



Write today for complete information and catalog.



**Electric Rotary Machine Co.**  
3825-E W. Lake St.  
CHICAGO, ILLINOIS

# The Anchor Line



## Anchor Stripper Blocks

Make the Ideal building block. Builders and Contractors like them because they are of uniform size and strength.

Take advantage of this preference and make your stripper blocks on the Anchor Stripper. Furnished with either the suspended tamper or the floor tamper with feeder and elevator.

Write us or your nearest Anchor representative for full particulars.

Start with a Single Unit—Add as You Grow  
**ANCHOR CONCRETE MACHINERY CO.**  
534 Dublin Ave., Columbus, Ohio

# ANCHOR

COMPLETE BRICK, BLOCK AND TILE EQUIPMENT

## Fireplace Trimmings



### Peerless Dome Dampers insure perfect fireplaces

You builders and contractors who want to satisfy your customers—here is the way to eliminate smoky fireplaces: A dome damper will prevent smoke and smoke discoloration, give control over the fire, save fuel, prevent soot falling into fireplace, prevent waste of heat, eliminate haphazard work in building fireplaces and insure a perfect draft at all times.

We carry a complete stock of dome dampers, grates, ash doors and traps, and all fireplace trimmings. Immediate shipments! Send for our big free catalog.

**Hornet Mantel Co.**  
1145 Market St. - - St. Louis, Mo.





**Buy  
Now  
Pay  
Later**

# Let Boice Help You Build It!

No matter what you build, Boice can help you.

## He'll send you the Boice-Crane Junior Saw

or any other Boice-Crane machine on monthly payments. He gives you unsurpassed values at lowest prices with a positive money-back guarantee. Machine shown will saw, sand, dado, grind, mitre, rabbet, tenon, etc. Sturdy, economical. This and larger Boice-Crane machines sold with or without motor.

Write today for Descriptive Catalog of complete line of Boice-Crane Bench Machines—Saws, Drills, Jointers, Band Saws—and the Boice E-Z-Pay Plan.

## W. B. & J. E. Boice

"World's Largest Makers of Small Bench Machines"  
Dept. A.B.3-A, Toledo, Ohio

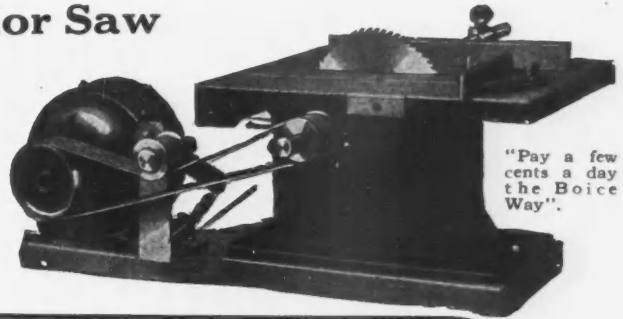

"Pay a few cents a day the Boice Way".



Huther Bros. Dado Head

## You Need a Huther Dado Head

The saw that makes intricate cutting and grooving simple.

This saw, developed from our own patents, consists of two outside cutters and a sufficient quantity of inside ones to perform the required cut. The outside cutters can be used singly or in pairs as required.

Every builder or contractor, wishing lock corners or any sort of grooving, will find his production costs lowered by this saw.

Write for complete information and prices, or send for one on approval. It may be returned at our expense if unsatisfactory.

## Huther Bros. Saw Manufacturing Co.

Rochester, N. Y.

Makers of Better Saws for More than 20 Years

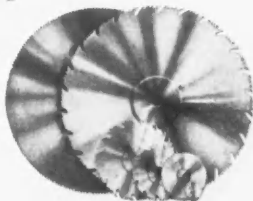

Huther Bros. Hollow Ground Saw

# COULSON Store Fronts Fit Your Needs

Whatever you are, whatever your business, there's a **Coulson** design, distinctive and harmonious, ready to be built in to meet the needs of your business.

## Contractors and Architects Approve

**Coulson** store fronts meet emphatic approval from contractors and architects, because they meet the most exacting demands, structurally and in attractiveness.

Cresoted wood encased in heavy copper, insures longer life, and reinforcing steel ties in corner posts, Division and Transom Bar Stops make stability certain.

For Further Information Write

## J. W. Coulson & Company

95-107 W. Spring St.  
Columbus, Ohio

AN AGENCY IS  
PROFITABLE,  
INVESTIGATE  
NOW.

# DIAMOND

PRACTICAL METAL  
THE DIAMOND  
WEATHER WAY STRIPPING

A PERMANENT BUSINESS  
THE YEAR ROUND.  
DEMAND  
CREATED

EXCLUSIVE  
TERRITORY TO  
BUSINESS PRODUCERS

ADDRESS AT ONCE  
THE DIAMOND  
METAL WEATHER STRIP CO.  
COLUMBUS, OHIO.

**HESS** CABINETS  
*and MIRRORS*  
Snow-White Steel



Churchill Hotel  
Chicago

H. L. Stevens & Co.  
Architects

HESS  
CHICAGO

**THE** Churchill Hotel, Chicago, is another of the numerous fine, modern hotels equipped with Hess snow-white steel medicine cabinets and lavatory mirrors. The beautiful satiny, hand-rubbed finish and the sanitary, non-warping steel construction make the Hess essential in the modern high-class bathroom.

*See Sweet's Index; or write for illustrated "Cabinet and Mirror" catalogue.*

**HESS WARMING & VENTILATING CO.**  
Makers of Hess Welded Steel Furnaces.  
1220 S. Western Avenue, Chicago

Use  
**FULLER & JOHNSON**  
EASY TO START  
ENGINES

**It Outlived the Mixer!**

**A Wisconsin contractor\* writes:**

"We used a 7 H. P. Fuller & Johnson Engine on a 7-S Heavy Duty Mixer continuously for 3 1/2 years, with no delays due to engine trouble. By that time the mixer's dump pans were completely worn through. Then we had the mixer rebuilt, hooked on the same engine, and the outfit is good as new."

\*Name and address on request.

**What size do YOU need?**

Fuller & Johnson Model N Engines, built for contractors, may be secured in stationary or portable types 1 1/2, 2 1/2, 3, 5, 7, 9 and 12 H. P. Other models up to 25 H. P. Catalog free on request.

**FULLER & JOHNSON MFG. CO.**

Engine Specialists  
Established 1840

**30 Alma Street  
Madison, Wis.  
U. S. A.**

**Built in Sizes  
1/2 to 25 H. P.**

**Stationary or  
Portable.**



**The Engine for the Contractor.**

**EASY TO START**



**CUT THE ICING COSTS**

The HERRICK Outside Icing Refrigerator saves ice bills during the cooler months because it permits the cold air to pass from the outdoors into the ice compartment. Serves the same purpose as ice at no cost whatever to the home owner. Prevents the kitchen floor from being tracked with muddy feet and dripping ice.

Write for free blue prints showing dimensions, etc.

**HERRICK REFRIGERATOR CO.**  
105 River St., Waterloo, Iowa

*"WhiteKraft" Cabinets*



The worlds largest manufacturers of hospital equipment are now prepared to supply steel medicine cabinets in any quantities. Betzco White Kraft cabinets are made from the same fine materials and finished with the same fine finish used in making Betzco aseptic steel furniture for hospitals.

**In America's Finest Buildings**

America's leading architects have accepted this new product of the White Kraft shops for their finest buildings. Fine Hotels, fine Apartment Buildings, and beautiful Homes everywhere are being equipped with White Kraft built-in cabinets.

If your requirements call for cabinets of superior quality the White Kraft shops can build them.

**Frank S. Betz Company**  
HAMMOND, IND.

*Write for New Builders' Booklet*



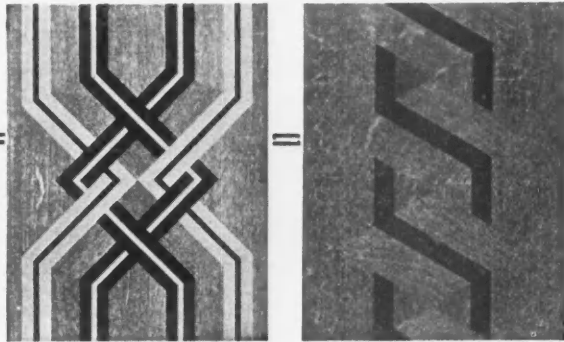

## WOOD-MOSAIC FLOORING

Is ideal for any home, public building or store window.

**Wood-Mosaic** makes a most artistic, sanitary and economical floor covering.

It is easily installed in old or new buildings and greatly increases the value of the property.

Let us tell you all about this profitable business that awaits you. Write at once.

Architects of the highest artistic reputation find us prepared to execute their designs in the most perfect manner. There is no practical wood which we do not carry in stock and there is no idea too difficult for us to execute.

Take advantage of this service. Write for our beautiful colored catalog and our book showing installations in every part of the country.



**WOOD MOSAIC COMPANY, Inc.**  
New Albany, Indiana



## Sturdy and Accurate

A glance at the cut shows how *substantially* this Builders' Convertible Level is made. In addition, it possesses an accuracy that is absolutely dependable. A quality instrument at a reasonable price.

*Circular on Request*

## EUGENE DIETZGEN CO.

Right goods at right prices  
continuously since Year 1885

Branches:  
Chicago New York  
New Orleans Pittsburgh  
San Francisco



Philadelphia Washington  
Factory:  
Chicago, Illinois

## SOLVES THE SMALL KITCHEN PROBLEM

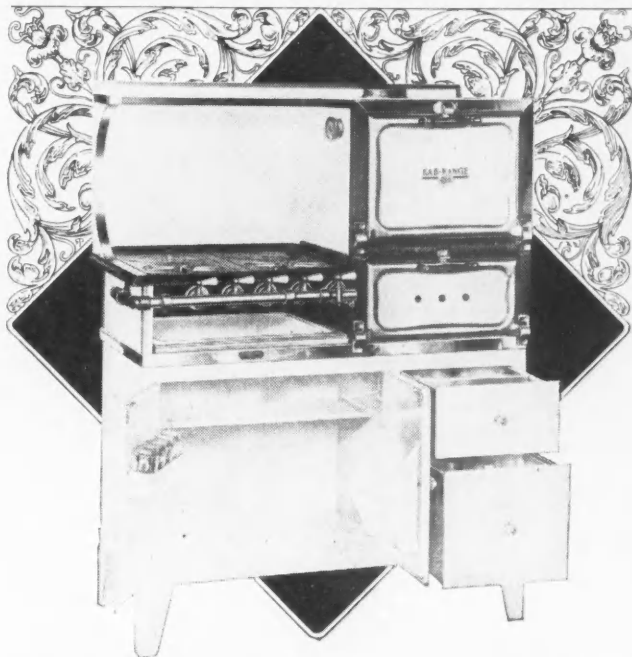

Kab Range solves a big problem for the builder—that of utilizing small kitchen space to the best advantage. Combines the Packer All-Steel Kitchen Cabinet and the Packer Rapid-Fire Range in one—together with the distinctive features of each. Made in models for any requirement. Write for complete information and prices today.

THE OHIO STATE STOVE & MFG. COMPANY  
Main Office and Factory, Columbus, Ohio

# The KAB-RANGE

WHEN WRITING ADVERTISERS PLEASE MENTION THE AMERICAN BUILDER

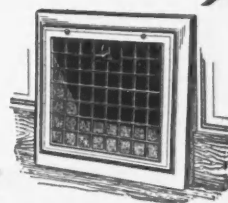

**"They Sell Homes"  
By Their  
Economy and  
Lasting Service**



*The Sign of Quality*

**NO STREAK** Registers are **GUARANTEED** not to discolor walls, which assures economy of decorating for you and the Home Owner.

The initial cost is insignificant compared to the saving. For example, the usual life of the wall decoration is three years and the average cost \$18.00 per room, or \$6.00 per room per year.

The life of decorations, using **NO STREAK** Registers, is seven years and the cost per room per year, \$2.60, which is a saving of \$3.40 per room, or \$27.20 for an 8-room house each year.

Our guarantee to prevent discoloration assures you of this saving and will sell your homes.

Specify the Only No Streak register manufactured because the cost is no more than other registers.

*Useful Booklet and Souvenir Mailed  
on Receipt of This Coupon*

**ROCK ISLAND REGISTER CO.**  
ROCK ISLAND, ILL.

**R. I. REGISTER CO.**  
You may read **FREE BOOK** and  
complete information.  
Name.....  
Town.....  
State.....  
A. B.



# The BESSLER Movable Stairway



A Practical Stairway for Practical Builders

Although the Bessler is the only patented stairway that slides up into the ceiling when not in use, there is nothing freakish about it. The Bessler is just as substantial as a stationary stairway of the same size. It is very easy to install.

Send for Descriptive Booklet.

The Bessler Movable Stairway Co.  
1901 E. Market St. Akron, O. New York Office 220 E. 41st St.

# A ONE PIECE Floor Anchor

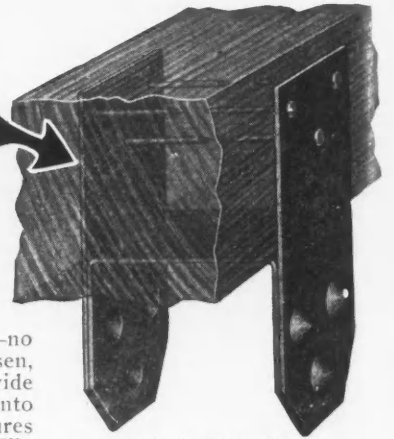

Nothing to come apart—no joints or hinges to loosen, break or corrode—a wide anchorage surface to set into the concrete. These features of the Bull Dog Floor Clip are made possible because it is stamped in one piece from heavy galvanized steel. The Bull Dog Floor Clip holds first place with leading architects and contractors of America because of its superiority.

Made in Three Sizes  
Bull Dog Floor Clips are made in sizes for 2 x 2, 2 x 3, and 2 x 4 sleepers—a size for any requirement.

The Bull Dog Floor Clip makes possible big savings in construction costs. Our twenty-six page catalog contains detailed figures, blue prints, architectural specifications—everything you need to analyze the Bull Dog Floor Clip method and convince yourself of its merits. Write for this literature today.

BULL DOG FLOOR CLIP CO.

Put the BULL-DOG on your Pay-roll

108 North First St. Winterset, Iowa  
78 Representatives 15 Distributing Points



# BULL DOG FLOOR CLIPS

# G & B Junior Latest Type Convertible Level

The World's greatest Level and Transit Combined

**\$500** Will Bring It To You Complete. Deposit cheerfully returned if not satisfied



U. S. Pats.

Changed to a Transit in 10 seconds, no extra or loose parts. No technical knowledge required, you can learn in 30 minutes. Book of Instructions FREE. Avoid regrets. Try a G & B Junior first. Low in price high in quality.



10 Days Free Trial  
Powerful Lenses, ground Vial, silver plated and graduated Circle and all other features of a good, accurate, durable Convertible Instrument.

Why pay a big price when we guarantee the G & B JUNIOR to fully answer your requirements. Accurate Speedy and Reliable. Write AT ONCE for Circular E. Write NOW.

GEIER & BLUHM, INC. 670 River Street TROY, N. Y.

# Lane's Trolley Parlor Door Hangers and Track

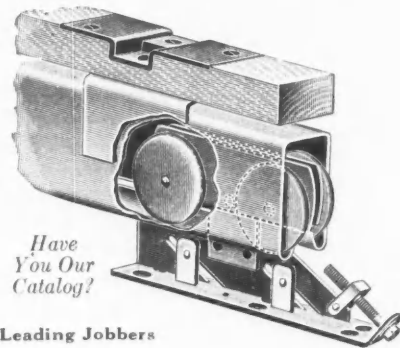

Have You Our Catalog?

Sold by Leading Jobbers

With bicycle quality ball-bearings and patented side adjustment of track (readily accessible after it is hung) makes it impossible for door to scrape or bind.

LANE BROTHERS COMPANY  
CARROLL STREET  
POUGHKEEPSIE, N. Y.

# The HELM Improved Simplex Mixer

will get those rush jobs of yours done on time.  
Because it's a specialized contractors mixer of FULL BATCH capacity and gives faultless service day after day. Every batch is a perfect mix.  
Equipment includes direct chain drive, double mixer blades, full batch hopper, Novo engine, standard tread wheels and a 5" x 2" channel iron frame.  
We also manufacture the well known Helm Press of 15,000 concrete brick or 1,500 concrete block daily capacity.  
*Write for Our Catalog*

**HELM BRICK MACHINE CO.**  
179 Mitchell St. Cadillac, Mich.



## A Most Extraordinary Floor Plate

different than any plate you have ever seen—more economical—more effective.

### CENTRAL FLOOR PLATES

weigh considerably less per area covered than any other plate. Their remarkable gripping surface is anti-corrosive and easily cleaned. They cost you 2 to 2½% less.

*May we quote you?*

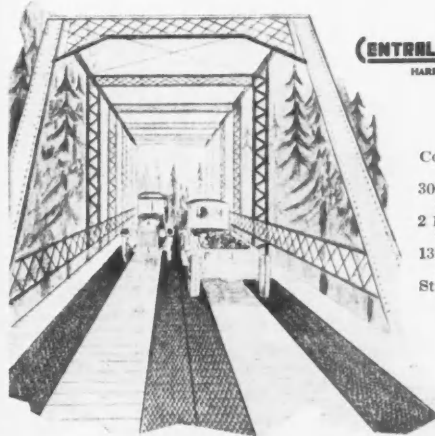

**CENTRAL IRON & STEEL**  
HARRISBURG, PENN. U.S.A.

**District Offices**  
Continental Bldg., Baltimore, Md.  
301 Seltz Bldg., Syracuse, N. Y.  
2 Rector St., New York City.  
131 State St., Boston, Mass.  
Stock Exchange Bldg., Philadelphia, Pa.

**Representatives in all large cities**

## CENTRAL FLOOR PLATES

## No Lost Tools —when you MARK them!



Identify them with a steel stamp or burning brand—buy direct from the manufacturer and cut your costs—hand-made or machine-made for stamping wood or metal.

New illustrated folder B-3 lists dozens of items you need—stencils, cement markers, badges and metal checks, rubber stamps and accessories. Ask for it. Maybe you need stamps or markers made to special specifications; estimates promptly given.

**The R. D. Swisher Mfg. Co.**  
411-413 S. Clinton St. CHICAGO, ILL.

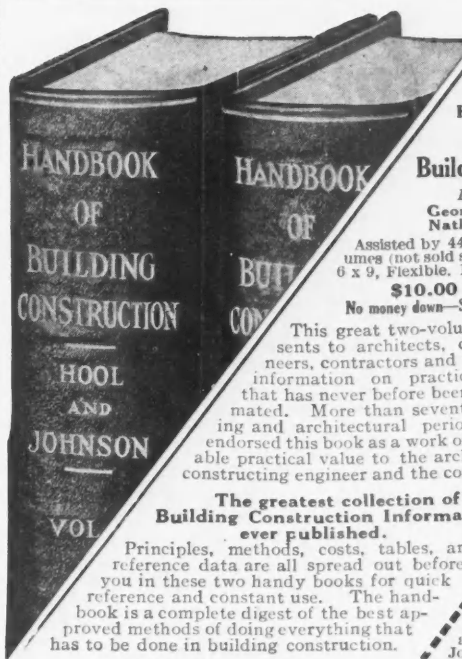

**Examine it for 10 days FREE**

**Hool and Johnson's Handbook of Building Construction**

*Editors-in-Chief:*  
**George A. Hool and Nathan C. Johnson**  
Assisted by 44 Specialists, Two Volumes (not sold separately), 1474 pages, 6 x 9, Flexible, Fully Illustrated.

**\$10.00 PER SET**

No money down—Small Monthly Payments

This great two-volume handbook presents to architects, construction engineers, contractors and builders a body of information on practical construction that has never before been even approximated. More than seventeen engineering and architectural periodicals have endorsed this book as a work of incomparable practical value to the architect, the constructing engineer and the contractor.

**The greatest collection of Building Construction Information ever published.**

Principles, methods, costs, tables, and reference data are all spread out before you in these two handy books for quick reference and constant use. The handbook is a complete digest of the best approved methods of doing everything that has to be done in building construction.

**See it for 10 days FREE.**

It costs but a two-cent stamp to get the handbook for ten days' free examination with the full privilege of sending it back if you decide not to keep it—and to keep it means only fourteen cents a day. **On that fair basis—send the coupon!**

**McGraw-Hill Book Co., Inc.**  
370 Seventh Avenue, New York.

Send me on 10 days' approval, Hool and Johnson's Handbook of Building Construction. (Two Volumes, \$10.00.) I agree to return the books, postpaid, in 10 days or to remit \$4.00 in 10 days and \$3.00 monthly for only two months thereafter.

Name.....

Address.....

Official Position.....

Company.....

**Worth much more than fourteen cents a day but that's all it costs**

A.B. 3-1-25

## Kimball Straight Line Drive

This Kimball Straight Line Elevator Drive eliminates the possibility of dis-alignment between the worm shaft and the motor rotor because the motor is bolted to the machine frame as an integral unit.

Write for further information.

*There is a Kimball Elevator built for every requirement*

**KIMBALL BROS. CO.**  
989-97 South 9th Street Council Bluffs, Ia.

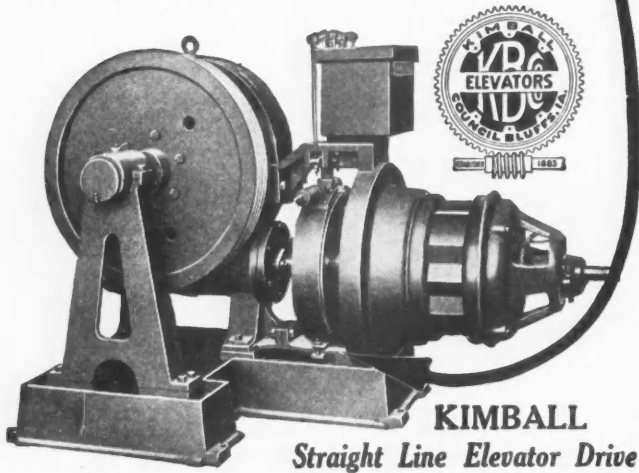

**KIMBALL**  
Straight Line Elevator Drive

## Fiske Brick



**B**UILDERS who seek distinction in color and texture of face brick find the answer in Fiske Brick.

"TAPESTRY"—The rough-texture brick with a wealth of color variations.

"FISKLOCK"—The two-in-one brick with the beauty of "TAPES-TRY".

### Fiske & Company

Incorporated  
BOSTON

New York

Watsonstown, Pa.

## The Improved SCHLUETER

Owes its popularity to its perfectly balanced automatic roller, silent chain, solid one piece aluminum dust pan, perfect vacuum system of dust collecting, its ability to do six men's work and do it better and the total absence of vibration. This sturdy machine requires no experienced operator and will surface right up to the quarter round without the use of an edge roller.

A Five Year Guarantee and a Five Day Free Trial offer absolutely protects the purchaser and makes owning a SCHLUETER easy for both large and small contractors. It will usually pay for itself with the profit on one large job.

Write for our proposition  
**Lincoln-Schlueter**  
Machinery Company  
Incorporated  
222 W. Illinois St.  
Chicago, Ill.



## MYERS SELF-OILING BULLDOZER POWER PUMPS

TWELVE SIZES CAPACITIES 500 TO 9000 GALLONS PER HOUR

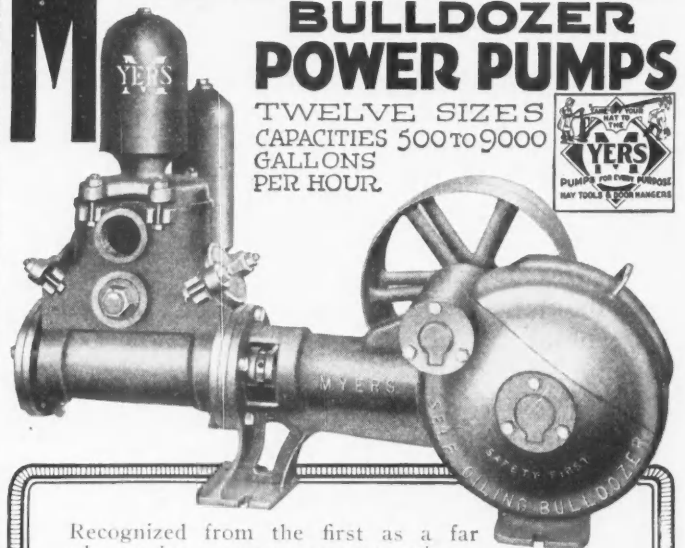

Recognized from the first as a far advance in power pump construction—copied from the first because of radical departures in design, special improvements and method of operation—they stand supreme today. Self-oiling—enclosed working parts—improved method of power application—extra large valves—make possible a new standard of service not approached by old style power pumps. Twelve sizes for shallow service—five sizes for deep service.

Catalog and information on request.

**THE F.E. MYERS & BRO. Co. Ashland, Ohio.**  
—ASHLAND PUMP AND HAY TOOL WORKS—



**"PULLMANIZE YOUR WINDOWS"**

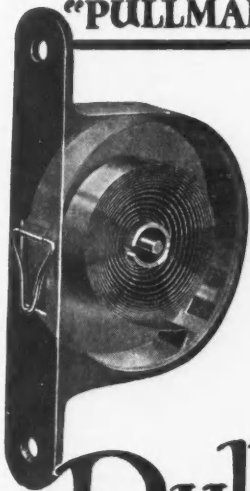

**Over 6,000,000**  
Pullman Sash Balances  
in use, a fact that gives  
them an assured standing  
of practicability, reliability  
and durability

On the Market for over 30 Years

*Installations with a record of more  
than 25 Years of continuous satisfactory  
service proves their wearing qualities*

**Pullman**  
Sash Balances  
with the  
New Tape Hook

*Sold on a ten Year Guarantee*  
Free illustrated Catalogue, full of modern  
window operating information on request

**Pullman Mfg. Co.**  
238 South Ave.  
Rochester, N. Y.

*This new Tape Hook makes it  
possible to fasten or unfasten the  
tape from the sash while sash is  
in place. No fussing with the stop;  
no mars or scratches; no refinishing;  
no lost time.*

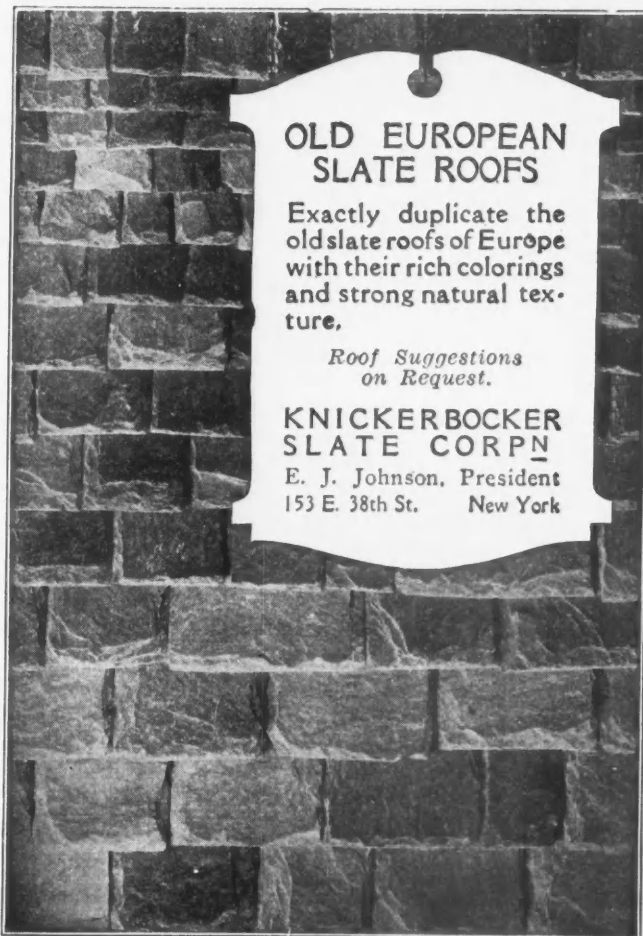

**OLD EUROPEAN  
SLATE ROOFS**

Exactly duplicate the  
old slate roofs of Europe  
with their rich colorings  
and strong natural texture.

*Roof Suggestions  
on Request.*

**KNICKERBOCKER  
SLATE CORPN**  
E. J. Johnson, President  
153 E. 38th St. New York

**Multiple Oval Cores Allow Use  
of Wet Mix Concrete**

We are the originators of the core method  
whereby the small oval openings in block guar-  
antee against collapse. Thus wet material can  
be employed. Simplest and best method for pro-  
duction in various lengths of block.

Our coring system allows for plenty of wall ven-  
tilation giving air space from top to bottom of  
wall.

Machine makes hollow or outside blocks and  
thin blocks for veneer and inside partitions.

U. S. Standard block are made face-down and  
are dense, strong and waterproof.

**U. S. Standard  
Block Machine**

Ask for details  
about this — one  
of the oldest and  
most widely used  
block machines  
on the market.

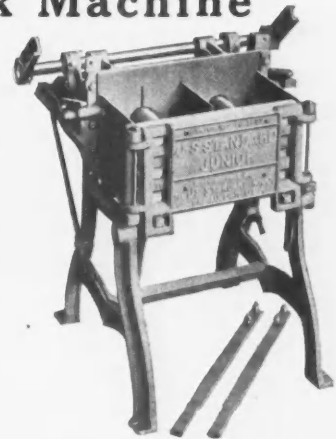

**U. S. Standard  
Manufacturing  
Co.**

130 W. Railroad St.  
Columbiana, Ohio



**FREE  
Engineering Counsel  
to Contractors and Home Builders**

The nation-wide KEWANEE organization is  
always ready to give expert counsel FREE on  
problems of private water-supply, electric light  
or sewage disposal.

KEWANEE men are not salesmen nor ex-  
plumbers; they are hydraulic-electric engineers,  
carefully selected and KEWANEE trained.  
Back of them is the quarter century of  
KEWANEE engineering and manufacturing  
experience in private systems.

Today the KEWANEE line covers over 200  
models of such systems.

*Send in the coupon below for helpful  
KEWANEE literature — FREE.*

**KEWANEE PRIVATE UTILITIES COMPANY**  
424 Franklin Street, Kewanee, Illinois



**KEWANEE**  
"Bungalow Model"  
Water Supply  
System

Now \$140.00



Kewanee Private Utilities Co.  
424 Franklin St., Kewanee, Ill.

am a.....  
[ ] Contractor  
[ ] Dealer  
[ ] Home Owner

Gentlemen: Please send me complete information on the following:

- [ ] Kewanee "Bungalow Model" Water Supply System
- [ ] Kewanee Sewage Disposal
- [ ] Kewanee Line of Water Supply Systems
- [ ] Kewanee Electric Lighting

Name.....  
Address.....

15 Sizes  
1½ to 30-inch Blades

**FOR ENDURANCE**  
**“YANKEE” Plain Driver No. 90**

This driver will stand up under all kinds of constant heavy service



Blades cannot turn in the handle. They are made of the highest grade steel, and will not break. You have our unlimited guarantee.

ASK YOUR DEALER TO SEE THEM

**NORTH BROS. MFG. CO., Dept. A. Phila., Pa.**  
North Philadelphia Station

A postal will bring you our Tool Catalog

Please mention this magazine.

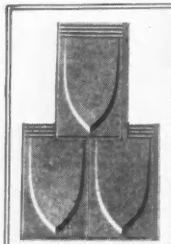

Fig. 157

Note the construction of patent interlocking device used on Edwards Metal Shingles and Spanish Tile



Fig. 367

Metal Spanish Tile for main part of roof

**Edwards “Queen Anne” Metal Shingles**



RESIDENCE SENATOR GEO. S. NIXON, NO. 5714 A, EDWARDS METAL SPANISH TILE USED ON THIS BUILDING

**EDWARDS Metal Spanish Tile**

It is wonderful what a remarkable transformation takes place when an “Edwards” Metal roof is properly applied to a house—all of the charm of the Old Spanish Terra Cotta Roofing Tile is preserved, even to the color.

The house takes on a new lease of life. It seems a better place to live in. It helps put the stamp of progressiveness and thrift on a community. An Edwards Metal or Tile Roof is a real commercial asset and will bring a better return in rent or sale.

Edwards Metal Roofings made in various styles, to have the appearance of wood shingles, tile, slate, or any other roofing effect, and none of these fine artistic effects will cost any more than a plain, commonplace roof.

All Edwards Metal Roofing is easy to lay—no big expense for skilled labor—storms and winds will not wrench it loose or make it a rattle-trap. It is lightning-proof and fire-proof—Reduces Insurance Rates.

When an Edwards Roof is laid, it is there to stay

Send for our literature—it explains

**The Edwards Mfg. Co.**  
401-417 Eggleston Ave., Cincinnati, Ohio

The World's Largest Manufacturers of Metal Roofing, Metal Ceilings, Metal Garages, Portable Buildings, Rolling Steel Doors, etc.

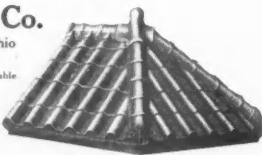

**STRUCTURAL SLATE**

**USE IT**

for Stairways, Floors, Shower Stalls, Toilet Enclosures, Urinal Stalls, Tubs and Sinks.

Structural Slate is Permanent, Sanitary and Economical.

It “outlasts the very building”—remaining always in excellent condition.

Send for interesting Slate Booklets.

**The Structural Slate Co.**  
104 Robinson Ave. Pen Argyl, Pa.

**STRUCTURAL SLATE**

**LUFKIN**

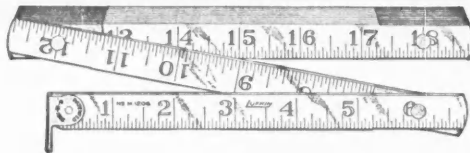

**ALUMINUM RULES**

**ACCURATE DURABLE LIGHT WEIGHT RUST PROOF**

These rules are of special hardness, therefore hold their shape well.

Distinct sunken black markings. Solid brass joints.

Can be furnished with Folding Hook, the feature that proved so popular on our Spring Joint Wood Rules.

CALL FOR **LUFKIN** RULES, BOXWOOD, SPRING JOINT, ALUMINUM, STEEL.

STOCKED BY SUPPLY HOUSES  
Send for Catalog

**THE LUFKIN RULE CO.**

SAGINAW, MICH.  
New York London, Eng. Windsor, Ont.

# THIS WISSLER PATENTED LEVEL

AT A SPECIAL LOW PRICE FOR ONE MONTH ONLY

Write at once for CIRCULAR and FREE TRIAL—TERMS if desired.

A Transit and Level combined. Saves time and money. Simple and practical—always ready for use. It costs you nothing to try it. Full instructions free. Sent on approval to any established builder—money will be refunded if not entirely satisfactory.

Beware of imitations. We are the inventors and sole owners of this Patented Level. All infringements are liable to prosecution.

We also manufacture a complete line of Transits and Levels for Architects, Builders, Surveyors, Civil Engineers, etc., from \$25.00 up.

## WISSLER INSTRUMENT CO.

633 N. Broadway

ST. LOUIS, MO.

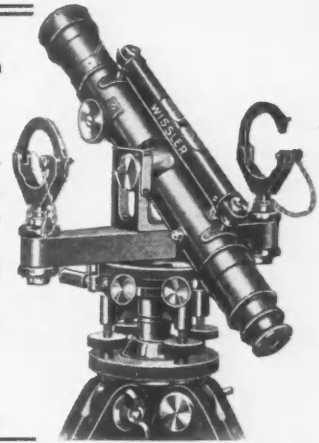

### Get Into the Floor Surfacing Business While the Field is Fresh

A CHANCE to have a business of your own and still retain your present position. Write today—Let us tell you how to get started in this Paying Business and how you can make good by following our method in working up your business. Free Trial. Part down—balance easy payments, which machine will earn for you. \$40 to \$50 a day easily earned with the AUTOMATIC—the result of 16 years mfg. experience. Will save the wages of 5 men and do work that will stand inspection against the light. SKF ball bearings, carefully protected from dust—Whitney Silent Chain—Roller Pressure Regulator—Force Feed Lubrication—Edge Roller Border Work Eliminated—Steel, not cast iron, construction—all dust taken up on forward operation with New Vacuum Nozzle—all working parts inclosed—2HP Alternating Motor on 12 inch machine.

The Little Automatic Surfacing Machine (on table) is a wonder for removing varnish from desk tops, counters, etc., or for all sorts of new work.

WAYVELL CHAPPELL & CO.

38-40 Jackson St., Dept. Z

WAUKEGAN, ILL.

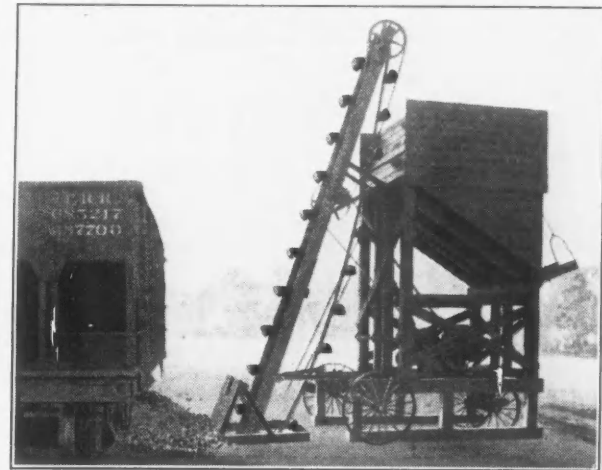
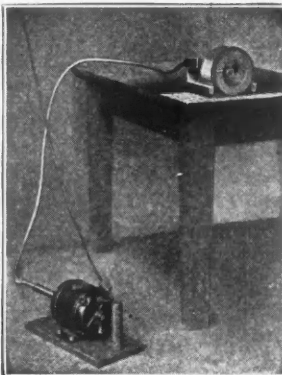

### HERCULES—Standard Equipment on the Good Roads Machinery Company's Portable Car Unloaders

Where nothing but the most absolute reliability will do, manufacturers choose the Hercules Engine. They take no chance on anything but the best—*nor should you*. There are dozens of jobs that a Hercules can do—and speed up. Hoists, air compressors, conveyors, mixers, crushers, saw rigs—any of them backed with the power of the rugged Hercules Engine will make fast time of the toughest job.

Hercules Engines are all tested under a continuous pulling load. They have the minimum of wearing parts, and the surefire Wico Magneto provides a never failing spark under the worst conditions.

Hercules Engines are backed by a nationwide organization. There are 350,000 of them doing satisfactory work throughout the country so you'll find a Hercules dealer near by.

#### THE HERCULES CORPORATION

Engine Division G

EVANSVILLE, IND.

## With the Kennedy Utility Saw On the Job, You Will Never Miss the High Priced Rigs

**\$38.50**

Takes Saws from 6 in. to 10 in.  
Will Take 2-inch Dado



**TO DEALERS:**  
Write for our proposition on this fast-selling saw.

say it's the best value, or mail coupon for full information on this and other models.

Ralph M. Kennedy, 111 No. 7th St., Philadelphia, Pa.

Connect with any lamp socket and begin work. Takes saws from 6" to 10". Will rip or crosscut up to 3 1/2 inch material. Cuts any angle. Table tilts to 25 degree angle. Table is 13 x 22 1/2", with throat 2 x 10" and will take dado blades up to 2 inch width. Made of best grades of iron and steel and all parts accurately machined. Spindle is supported rigidly by two ground and hardened ball bearings. End of spindle bored to take drill chuck, or will support emery or sander. By exchanging pulleys you can reduce speed and use a saw for cutting metal. Takes only 7 x 14 inch bench space. Weighs about 50 pounds.

Price, including pulley, two guides, one 7" crucible steel saw, and spindle sleeves for use with dado, \$38.50. Furnished complete with 1/2 H.P. motor for \$58.50. Prices f.o.b. Philadelphia.

A 1/2 H.P. motor furnishes sufficient power for practically all work, but for capacity cutting with 9 or 10 inch saw we recommend a larger motor, which we can furnish at a saving. Send check or money order and put the Kennedy to work. Your money back if you don't. Send for the saw and let it talk for itself.

RALPH M. KENNEDY 111 No. 7th St., Philadelphia, Pa.  
Please send full information on all models of the Kennedy saw.  
Name.....  
P. O. ....  
State .....



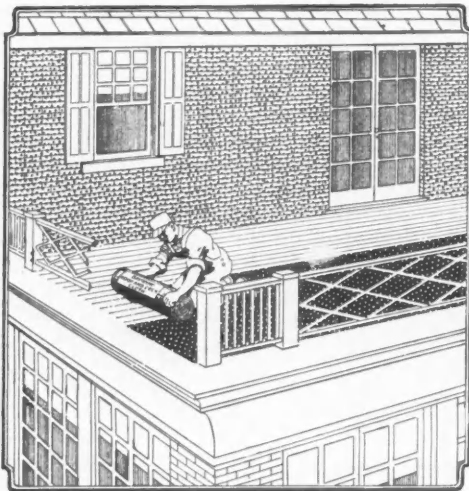

**"BAYONNE"**  
ROOF AND DECK CLOTH

Rain and snow, sunshine and heat have no effect on Bayonne. It is guaranteed waterproof and will not crack or buckle or peel.

*Write for Sample Book "P" and ask for one of our Repeat Memo Pads*

**JOHN BOYLE & CO., INC.**  
Established 1860  
112-114 Duane St. New York 70-72 Reade St.  
Branch: 1317-1319 Pine St., St. Louis

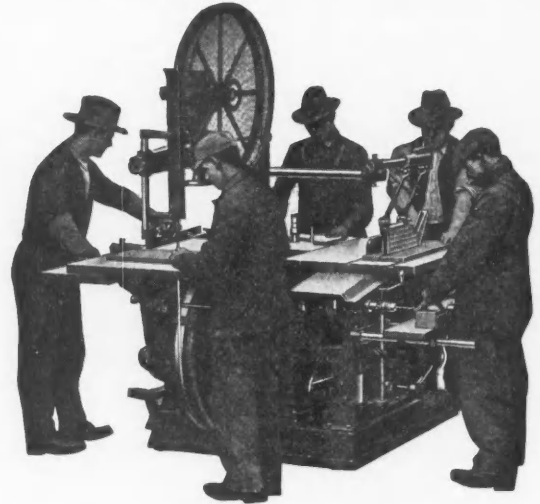

**The Overwhelming Popularity**  
of  
**The New Model Crescent Universal Wood Worker Nos. 101 to 112**

is only another evidence that the high standard of Crescent quality is appreciated by well informed users of wood working machinery.

Ask today for illustrated price list and we will send copy of catalog giving complete description of our line of band saws, saw tables, shapers, variety wood workers, jointers, planers and matchers, table cut off saws, swing saws, disk grinders, borers, hollow chisel mortisers, universal wood workers.

**The Crescent Machine Co.**  
224 Main St., Leetonia, Ohio

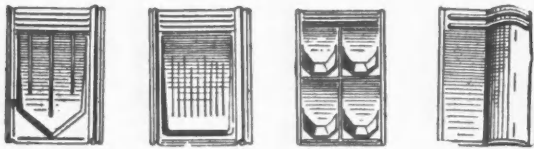
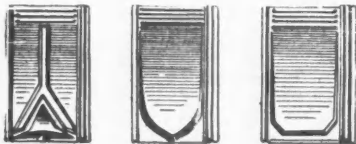

**MAKE A BIGGER PROFIT**  
**On The Roof**

Wise, thrifty builders will appreciate the saving in putting on Walters and Coopers Metal Shingles. The Walters and Coopers Metal Shingles weigh less than wood or slate and takes lighter frame work to support it. Moreover, it is permanent. This roofing does not require skilled labor to put it on, carries a low rate of insurance and is storm, wind and fireproof. We manufacture a complete line of designs in Painted Tin, Genuine Re-dipped Galvanized Tin, Sheet Zinc and Copper.

*Write for full size samples and prices*

**National Sheet Metal Roofing Co.**  
339-345 Grand St., Jersey City, N. J.

**MORE CASH-  
LESS LABOR**

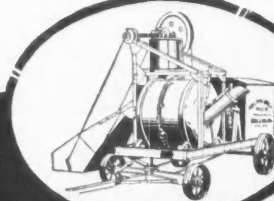
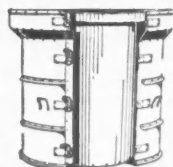
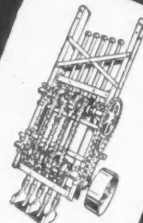
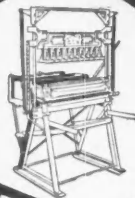

CRESCENT Concrete Machinery is money making equipment, built for quantity production without breakdowns. Our prices to you mean real savings in first cost and the quality of our machines means bigger profits for years to come with less back breaking labor.

**Write for Free Bulletin!**

- CRESCENT Sewer Pipe and Tile Moulds, Catalog 11 and Bulletin 33.
- Brick Machines, hand, foot and power. Catalog 32.
- Bull-dog batch Mixers. Catalog 37.
- Bull-dog Tilter Mixer, Bulletin 42.
- Power Block Tampers, Bulletin 36.
- CRESCENT Continuous Mixers, Catalog 10.

**Raber and Lang Mfg. Co.**  
828 Mill St., Kendallville, Ind.

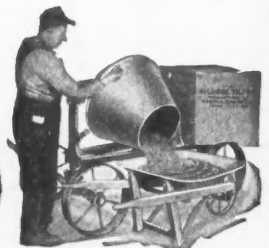

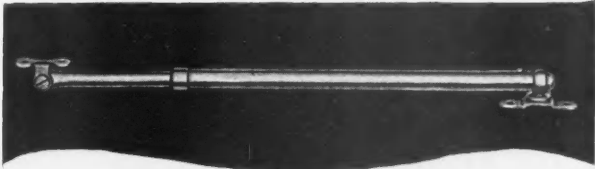

## Now Casements Stay Tight

Here's a handsome, sturdy device that holds casement secure regardless of wind or weather—the

# MONARCH

## Automatic CASEMENT STAY

Fits any casement or pivoted window, transom or other hinged opening—permits them to be opened or closed and securely locked at any angle—stops rattling, slamming and noise. Can be attached concealed or exposed at right, left, top or bottom.

### MANUAL FREE

"Manual of Casement Hardware Detail" gives methods of installation and complete list of finishes of Monarch Automatic Casement Stay, Monarch Control Lock and Monarch Casement Check. Sent free. Write to

**Monarch Metal Products Co.**  
4970 Penrose St. St. Louis, Mo.



Also Manufacturers of Monarch Metal Weather Strips

## They Double the Life of a Roof

HOT-DIPPED IN PURE ZINC

# Zinclad

REG. U. S. PAT. OFF.

*Nails double the life of a roof because*

## They Do Not Rust

They keep the shingles sound and snug and tight. They produce all the life in a roof and make your jobs twice as good as the other fellow's at very little extra cost.

WRITE US FOR FULL INFORMATION

**W. H. MAZE COMPANY**  
PERU, ILLINOIS

*Zinclads are made for all types of shingles*

## Announcement

# MAC-STONE STUCCO CO.

INCORPORATED

With Mills and Offices at  
1552-1562 TROY AVENUE  
BROOKLYN, N. Y.

Manufacturing

## A Full Line of Highgrade Oxychloride Products

*Invites Your Patronage*

Write to us for Literature, Samples and further Information

DIRECTORS

H. B. STOKES D. M. McPHERSON W. S. STEELE  
GEORGE V. McPHERSON C. A. DELEVANTE



Arch. Jos. J. Geigand specified 31 Walker Dishwasher-Sinks for the Crescent Apts., Buffalo, N. Y., and 36 for the Commodore Apts., Buffalo, N. Y.

## A New WALKER DISHWASHER-SINK

Will Improve the Renting and Sales Values of Your Houses and Apartments

The WALKER DISHWASHER-SINK is of heavy enameled ware—the equal of quality ware in your bathroom. It not only gives the kitchen new importance but saves space. It drives away the drudgery of dishwashing forever.

A Builder in Columbus, Ohio (name on request), says:

"One thing in particular I want to stress in this letter is the real fact that these sinks helped very materially in renting these apartments almost before the building was completed. We have not had one single call in the line of service from these eight sinks and in talking to the tenants at this apartment I believe they think more of the sink than they do of anything in the apartment."

The WALKER DISHWASHER is perfected by ten years' experience. Individual type of machine as well as this sink model approved by Good Housekeeping Institute and other testing laboratories as well as by thousands of users. Use the coupon below and indicate your interest in the sink or portable type. Full particulars will be sent you at once. Address Walker Dishwasher Corp., 348 Walton St., Syracuse, N. Y.



# WALKER

## Dishwasher & Dryer

*Washes Dishes Cleaner Than By Hand*

Different types and sizes for Homes and Apartments. Prices \$98 to \$215.

Without obligation, send me full particulars about the WALKER DISHWASHER AND DRYER  With Sink  Separate

Name \_\_\_\_\_ Address \_\_\_\_\_ Name of Home & Apartment \_\_\_\_\_

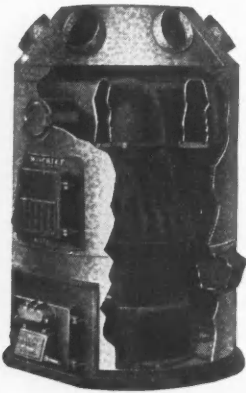

# MONCRIEF FURNACES

Experience counts in building furnaces just as it does in building houses. For that reason our thirty years' experience must have a definite assurance for you.

Write us about your heating problems. Send in your plans. Our Engineer will draw up complete heating specifications and quote you prices complete for all materials used on the job.

**Pipe — Pipeless — 3-Pipe — Majestic - Moncrief**  
**THE HENRY FURNACE & FOUNDRY CO.**  
3471 E. 49th St., Cleveland, Ohio



Ask  
Any "Old  
Timer"  
About  
the

# EMPIRE LEVEL

Those fine old mechanics to whom extreme accuracy is second nature are enthusiastic about this wonderful level. The Empire is made **Right**—that is why it is so popular. The famous Empire interchangeable case construction—for quick repair of broken glasses—is now available in both the wood and aluminum levels.

*If your dealer does not stock them write*

**EMPIRE LEVEL MFG. CO. Milwaukee, Wis.**



**UNBRANDED TOOLS AND EQUIPMENT "DISAPPEAR" LONG BEFORE THEY WEAR OUT**

You lose tools and equipment on nearly every job due to intentional or unintentional theft. Your tools get mixed up with others and the contractor with the easiest conscience comes out ahead.

Therefore, you have long felt the need of an inexpensive branding iron like the Everhot for quickly branding tools, scaffolding, sheeting wheelbarrows and other equipment. Complete Everhot equipments as low as \$14.00. Write for descriptive circular.

**EVERHOT**  
*America's Brand Makers*  
**EVERHOT**  
**MANUFACTURING CO.**  
MAYWOOD, ILLINOIS



Bovee's Horizontal Wood and Coal Furnace

# BOVEE FURNACES

*Established 1895*

**Reliable, Durable and Economical**

Manufactured in all sizes having 20-inch to 36-inch Fire Pots

Combustion chamber more than double the size of the average furnace.

**SAVE 40% IN FUEL**

Special to Contractors • Very Easy to Install. No Tinner Required.

Write for Full Information and Prices.



Compound Radiator Furnace

**BOVEE FURNACE WORKS, 50 West 8th Street, Waterloo, Iowa**



# Synonyms!

## PYRAMID STUCCO *And* DEPENDABILITY

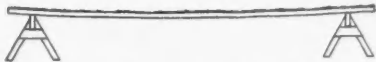

### FLEXIBILITY TEST

A half-inch coat of Pyramid Stucco, covering a board six feet long, can be bowed six inches from horizontal without fracturing the stucco.

You can rely on the uniformity of Pyramid Stucco, for scientific preparation and handling of ingredients insures a dependable uniform product.

The chemical composition of Pyramid Stucco—the result of years of study—produces a remarkably elastic stucco possessed of a tensile strength far in excess of that which is required in stucco construction.

Pyramid Stucco withstands time and the elements, and for years to come a Pyramid job is one of your best salesmen.

Yet—Pyramid is more economical than an ordinary stucco.

*Literature describing the distinctive qualities of Pyramid Stucco, specification booklet and price lists will be mailed you at your request.*

PYRAMID COMPANY, 231 S. Wells St., Chicago



PYRAMID COMPANY—MEMBER OF THE NATIONAL ASSOCIATION OXY-CHLORIDE CEMENT MANUFACTURERS



We will send you one of our nails that was in actual service for 40 years, if you will send us your name and address.

## Everlasting

### ZINC COATED NAILS

Manufactured by the  
**Malleable Iron Fittings Co.**

are truly Everlasting. The heavy zinc coating applied by the "hot-dipped" process makes them so.

You contractors in erecting buildings of quality cannot afford to use a cheap, inferior nail.

M. I. F. Co. Heavy Zinc Coated Nails have been put to the severest tests and have proved over and over again that they are rust-proof, and the most durable nails in the world.

*If your dealer does not handle our nails we will sell you direct.*

**MALLEABLE IRON FITTINGS CO.**  
Branford, Conn.



## "GRAND RAPIDS" All-Steel Sash Pulleys

are **LIGHTEST** yet strongest. Two-thirds of your freight is saved, yet a **BROKEN PULLEY IS UNKNOWN** in our product—and these superior **ALL-STEEL** goods cost no more than the common pulleys made of cast iron.

The No. 10 Ball Bearing Pulley illustrated here is one of our best known styles.

This Pulley has the automatic saw-tooth fastening feature which saves time and labor. No nails or screws required, yet the Pulley is held in place more securely than when fastened by any other method.

The bearing contains eleven ¼ inch solid steel balls running in lubricant, insuring a noiseless, easy running wheel under any load. This feature makes an excellent talking point for your window frames.

See this Pulley at your dealer's.

### No. 10 Ball Bearing

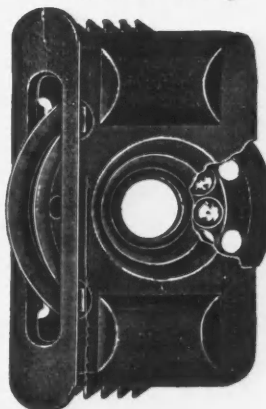

**Grand Rapids Hardware Co.**

560 11th St.  
Grand Rapids, Mich.

**Mail Coupon  
for FREE  
Sample**

-----  
**GRAND RAPIDS HARDWARE CO.,**  
 Grand Rapids, Mich.  
 I am interested in your No. 10 Ball Bearing  
 "Grand Rapids" All-Steel Sash Pulley. Please send me sample.  
 Name.....  
 Address.....  
 City.....  
 State.....

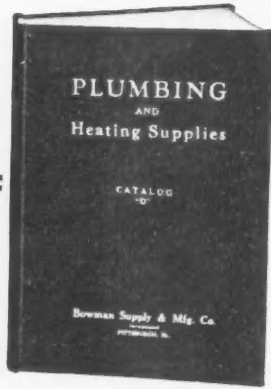

## BUILDERS!

You should have the "Bowman" catalog of plumbing and heating supplies in your files. Write today for this catalog and have a reference of the best.

**BOWMAN SUPPLY & MFG. CO., Inc.**  
878-892 Progress St., N. S. Pittsburgh, Pa.

## CASCO

*The guaranteed blackboard distinctly superior to natural slate.*

*Casco-applied like a hard finish plaster - forms a seamless blackboard of any size - a noiseless, smooth writing blackboard made of a stone and metal composition that will outlast the building.*

*Yet, - Casco artificial slate construction costs 25% less than natural slate.*

*Installed by any competent plasterer. Guaranteed absolutely satisfactory.*

**CHICAGO ARTIFICIAL SLATING COMPANY**  
129 North Dearborn St.  
CHICAGO

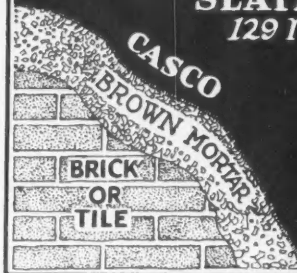

*Write for descriptive literature*

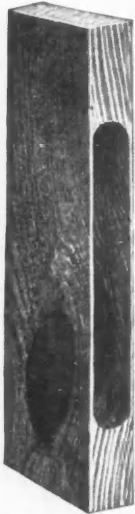

## Thru Knots or Dowel Pins!

No need to fear knots or dowel pins when cutting a mortise with the Champion Mortiser. It works with equal ease in any kind of wood, whether hard, soft, cross-grained or end wood. Cuts a perfect mortise of any desired length, width and depth "slick as a whistle."

The New Improved

**Champion Mortiser**  
Cuts a Perfect Mortise in a Minute or Two

—Is five times faster than the old-fashioned hammer, chisel and brace and bit method. No guess work is necessary. Anyone can operate it. A money saver and time saver. Carried anywhere. Cuts a perfect mortise  $\frac{1}{2}$ " to  $1\frac{1}{2}$ " wide and any length from round hole to 6" slot. Can be used on stock  $\frac{1}{4}$ " to  $2\frac{1}{2}$ " thickness. Special base for mortising wide stock furnished on request. Year's guarantee with each machine. Sent complete with choice of any two bits ( $\frac{1}{2}$ " to  $1\frac{1}{2}$ ") \$40.00 f. o. b. factory. Additional bits up to  $1\frac{1}{2}$ " furnished at \$2.00 each.

We also make motor-driven model, especially suitable for large jobs. Ask us about it.

**Money Back Guarantee**

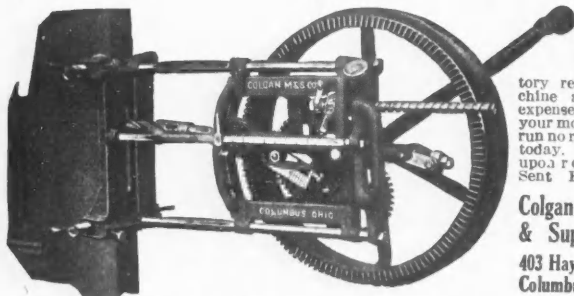

After ten days' trial if not satisfactory return machine at our expense and get your money. You run no risk. Send today. Circular upon request. Sent FREE.

**Colgan Mach'y & Supply Co.**  
403 Hayden Bldg.  
Columbus, Ohio

## HERE IT IS—THE ATLAS TRAILER

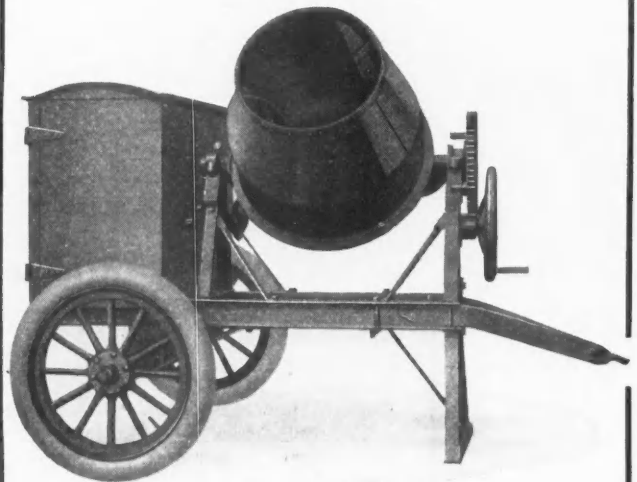

Sold at a price that will interest you.

Built in standard sizes also can be furnished with solid cushion tires. Spring mounting at a slight additional cost.

Write for General Mixer Catalogue and Prices

**ATLAS ENGINEERING CO.**  
3039 Galena St. Milwaukee, Wis.

# CROPP MIXERS

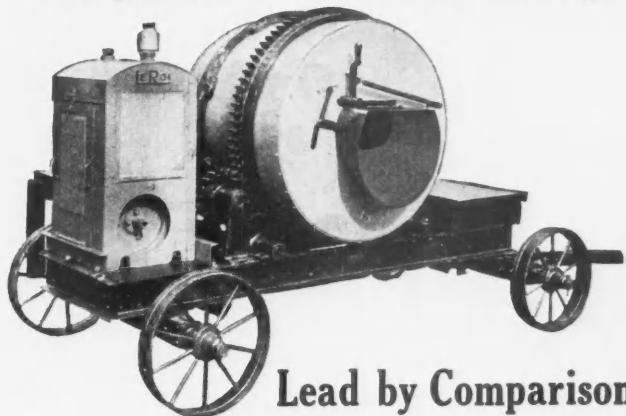

**Lead by Comparison**

On the firing line, where a mixer must stand the gaff of continual use, or go to the hospital, Cropp Low Charging Mixers lead the field. Discharges a full load with one revolution; takes a full wheelbarrow charge in one gulp; fast and thorough mixing action for a wet or dry mix; a reliable and accessible power plant. These are the Cropp Outstanding features. Send for full details on the New Cropp Models.

**TERRITORIES OPEN TO LIVE DISTRIBUTORS**

We have an unusually generous proposition for agents who want to handle a line of high grade Mixers.

*Write for particulars*

**B. M. CROPP CO.**

400 N. Claremont Ave.

Chicago, Ill.

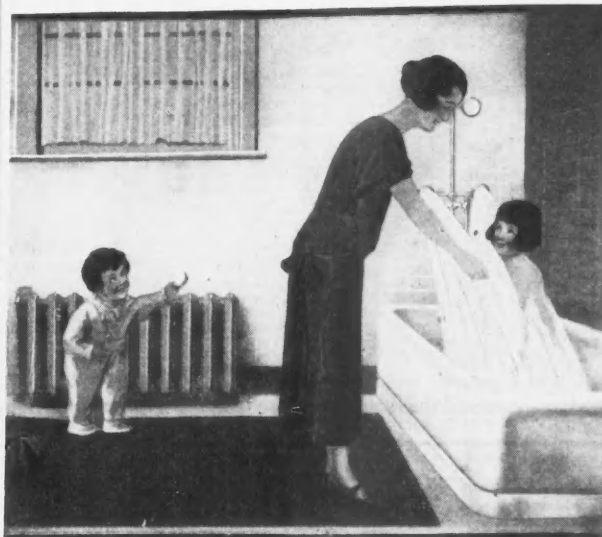

## THE MODERN HOME IS BUILT AROUND ITS BATHROOMS—

The time saved, convenience and healthful results of bathing in clean running water makes the shower a demand and a necessity for every bathroom. **THE KENNEY NEEDLE SHOWER** is the ideal shower—it puts the water where it is wanted—no overhead deluge. The converging stream principle eliminates the need for curtains. It is the economical shower and there's a model for every condition.

Write for Booklet B which explains why curtains are no longer necessary.

**THE KENNEY-CUTTING PRODUCTS CORP.**  
507 FIFTH AVE. DEPT. AM NEW YORK

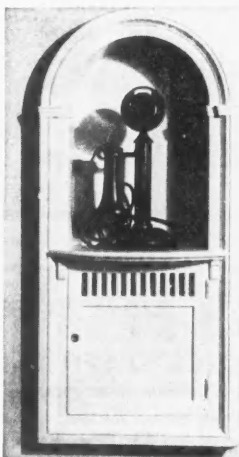

### The Phoenix Phone Cabinet

*For hotels, apartment houses, homes and offices.*

A decorative wall niche for the telephone.

Practical and most convenient.

Can be readily installed in old or new work in a wall or partition from 3 to 5 inches or over in thickness. It can be supplied in designs to meet your needs. Lower part conceals the bell box.

*Prices on request.*

**Phoenix Cabinet Co., Inc.**  
419 Union Bldg., Syracuse, N. Y.



## READY TO INSTALL

### The Limaco Ironing Board Cabinet

The Limaco steel ironing board saves

time and labor on installation because it comes ready assembled. Fits between standard studing. Made of heavy gauge steel sheets and assembled by the welding process. Insures a rigid and substantial job. The board is stamped from from 20 gauge steel and guaranteed not to warp. Finished in pearl gray enamel flat coat, making an ideal ground for any standard finish. Quantity prices.

*Write for Complete Data*

**LIMA SHEET METAL PRODUCTS CO.**  
LIMA, OHIO

### When You Want The Best Ask For The Germantown Master Builder—

for 66 years the standard of quality. If you cannot be supplied at your local dealer's

send for the Master Builder catalog of Hammers and Hatchets.

**GRIFFITH TOOL WORKS**  
Philadelphia, Penn.



**THREE SIZES**  
20 oz.  
16 oz.  
11 oz.

**GRIFFITH MASTER BUILDER**  
U.S.A.



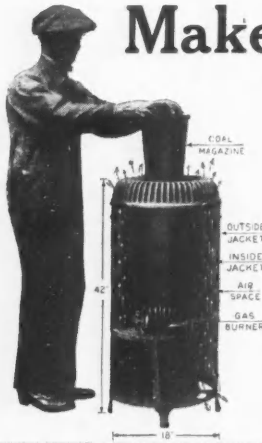

# Make More Profit on Every Garage You Build!

Sell the extras that make a garage complete. It's as easy for owners to finance complete job as it is a bare garage and you get the profits someone else would get later. It's

especially easy to sell the

**\$69<sup>50</sup>**

**Kan't-Freez**  
Warm Air  
Garage Heater

**F. O. B.  
Toledo**

Costs you nothing to install; your own men can do it. Kan't-Freez pays you a far bigger percentage of profit than garage building itself. Get this extra profit. Write today for full information and contractors discount.

The H. C. Baker Co., Factory Distributors 213 Michigan St., Toledo, O.



## INVISIBOWL CONCEALED-IN-A-WALL LAVATORY

*A Real Space-Saving Unit*

that adds beauty and distinction and can be installed in any wall. A built-in lavatory and cabinet occupying but four inches in depth, presenting the appearance of full length mirror when closed.

Ideal for Bed Rooms of homes. Other units suitable for Apartments, Office Buildings and Hotels.

*Write for Free Literature. Special Discounts to Dealers, Builders and Plumbing Contractors*

**INVISIBOWL MANUFACTURING CORP.**  
38 South Dearborn Street CHICAGO, ILL.

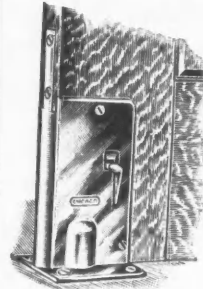

Relax Type 6001

TRADE **CHICAGO** MARK

**SPRING HINGES**

THE NOISELESS HINGE  
WITH  
A SPRING ACTION RELEASE

Recommended for CHURCHES,  
SCHOOLS, HOSPITALS, and RESI-  
DENCES.

*Send for descriptive literature*

**Chicago Spring Hinge Company,**  
CHICAGO NEW YORK

### The Woodworker's Friend

Jointers complete ready to use, also full line Jointer Heads and parts, bevel gauges for jointers. If you are doing woodwork of any kind, or have rough lumber to dress, get our circular and prices. They are interesting for any woodworker. Manufactured by

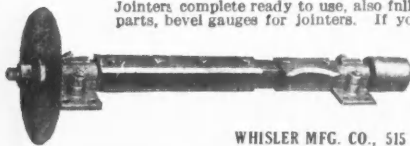

WHISLER MFG. CO., 515 W. Main St., Ottumwa, Ia.

### Smith's Washer Cutter

For cutting all kinds of leather washers, also pump packings, valves, etc. Made in two sizes, 3" and 6".



**SMITH'S ADJUSTABLE  
COUNTERSINK Drop Forged**

Manufacturers of Wrenches,  
Nippers, etc.

**OTIS A. SMITH** Manufacturing  
Company  
ROCKFALL :: CONNECTICUT



KEES  
METAL  
CORNERS  
for  
WIDE  
SIDING

### for Wide "Colonial" Siding

Make weather-proof mitred corners. No slow cutting and fitting.

Galvanized iron is treated to take paint and stain. Accurately formed.

For all widths of lap siding from 3 to 11 inches, and for drop siding. Samples and catalog free.

KEES MFG. CO., Box 91, Beatrice, Nebraska

*Jaeger  
Announces  
New Models in  
Concrete Mixers  
and 1925 Prices*  
See Pages  
10 and 11

## KILMOTH

Tennessee Cedar With the GOOD Left In  
Endorsed by Better Architects and Builders Everywhere

*Look for Further Announcements*

**KILMOTH PRODUCTS CORP., 58-A Union Sq., New York**

### DUMBWAITERS AT LOW COST

"The Highwood" complete, ready to install, 60-lb. capacity. Height 20 feet. \$34.50.

"The Syloan," 75-lb. capacity. Equipped with automatic brake. \$40.00.

"The Herculean," 200-lb. capacity. Equipped with gears and automatic brake. \$90.00.

*Write for Catalog No. 5 for specifications and prices.*

**HIGHWOOD DUMBWAITER CO., CLOSTER, N. J.**

## Lignine (Wood) Carvings—Unbreakable

Do not CHIP, CHECK, CRACK nor SHRINK. Capitals, Pilasters, Drops, Scrolls, Heads, Period Designs—Adam, Heppelwhite, Chippendale, Queen Anne, Modern, English and Italian Renaissance. **SAVE YOU BIG MONEY.** New Catalog No. 9 and sample FREE.

**ORNAMENTAL PRODUCTS CO.**  
14th Street at Lafayette Ave. Detroit, Mich., U. S. A.



*Jaeger  
Announces  
New Models in  
Concrete Mixers  
and 1925 Prices*

*See Pages  
10 and 11*

### UNITED CASEMENT ADJUSTERS



Our sole product since 1913

Just turn the tube to set the proper resistance, then forget them.

They give security and comfort and are indestructible.

**5 SIZES**

Write for information

United Specialties Manfg. Co.  
Jamaica, New York



### VERDOLITE MARBLE

*Is Best*

Use Verdolite Marble for Stucco Dash, Terrazzo Floors, Facing Concrete Block and Brick. Can be supplied in combination green and red.

We also manufacture the famous "Anchor Brand" mortar colors.

*Write for further information.*

**C. K. WILLIAMS & CO.**  
Easton, Pennsylvania

### GREATEST VALUE

PER DOLLAR INVESTED IS YOURS IN THE

### "Sterling" Convertible Level



Patented

*Write Today for Folder "F-28" and Free Pocket Note Book of Instructions*

**WARREN-KNIGHT CO.**  
136 N. 12TH St. PHILADELPHIA, PA.



### SILVER LAKE A Sash Cord

The guaranteed sash cord (since 1869 the standard) not only outwears common cords, but outwears chains and ribbons. The name Silver Lake A is printed on every foot of the genuine. Guaranteed full lengths.

**Silver Lake Co.**  
Newtonville, Mass.

*The Practical Workman is Sure to know the Reason Why*



### PLAN BOOKS

My books contain actual reproductions of drawings to 1/8 inch scale of Designs which have been built within the past few years.

"MODERN SINGLE HOMES" 30 Designs \$2.50 copy  
"TWO FAMILY HOUSES" 27 Designs \$2.50 copy

### PLAN SERVICE

Plans for all designs in my books are ready for prompt delivery and are mailed the same day order is received.

**NEW DESIGNS DRAWN TO ORDER**

**Grieme's Architectural Service Bureau**  
ENGINEERS BUILDING CLEVELAND, O.



### Genuine Franklin Tunnel

#### The Mark of Excellence in Slate Roofing

**GUARANTEES** to you the absolute uniformity in quality found only in this roofing of the ages.

It assures you of more than a lifetime of uninterrupted satisfaction.

Unexcelled beauty and quiet dignity are at once apparent in the home roofed with

### Genuine Franklin Tunnel Slate

*Write to us for samples*

**SLATINGTON SLATE COMPANY**  
SLATINGTON PENNSYLVANIA

### Never Needs Retempering

Why?

Because our "Old Fashioned" quality Adze has tool steel edge—tempers clear through. Wears twice as long.



-----

**THE L. & I. J. WHITE CO.**  
10 Columbia St., Buffalo, N. Y.

Send me copy of your catalog on Adze and where I can buy them here.

.....

.....

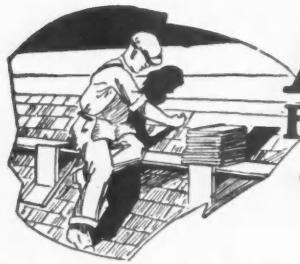

# AJAX

## Folding Metal Roofing Bracket

THE QUICKEST  
EVER AND AS SAFE  
AS THE EARTH UNDER  
YOUR FEET.

MANUFACTURED BY  
**AJAX BUILDING BRACKET CO.**  
1551 Rydal Mount Road, Cleveland Heights, Ohio

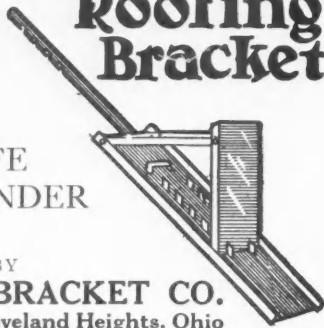

**THE BEST LUMBER**  
FOR THE OWNER OR THE INVESTOR TO PAY FOR IS  
**THE BEST LUMBER**  
FOR THE CARPENTER AND BUILDER TO USE.

Don't Forget That Good Reputations are Built on  
Good Recommendations. USE AND RECOMMEND

Tide Water  
**Cypress**  
"The Wood Eternal"

BECAUSE IT LASTS & LASTS & LASTS & LASTS

Look for this on every board—  
Accept no Cypress without this mark



# C.H.&E

Saw Rigs Elevators  
Pumps Mortar Mixers  
Hoists Engines

Write for our new catalog

**C. H. & E. Manufacturing Co.**  
322 Mineral Street Milwaukee, Wis.

## New—A COMPLETE IDEAL HOIST

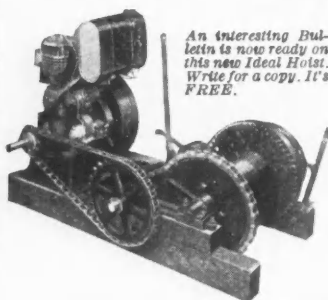

An interesting Bulletin is now ready on this new Ideal Hoist. Write for a copy. It's FREE.

The popular Hoist for all contractors. Simple in design and construction. Operates single or double cage elevators and any other place where there is a rope or cable to pull. Compact, easy to transport and will pass thru a 3 foot door or opening. Total weight of hoist and engine complete, only 750 lbs. Saves labor, makes money. Equipped with the well known "New Way" air-cooled engine. Light in weight, easy to start, easy to care for. The reasonable price of this complete outfit will appeal to you.

**Universal Hoist & Mfg. Co.**  
195 E. 14th St., Cedar Falls, Iowa

### Garage Necessities

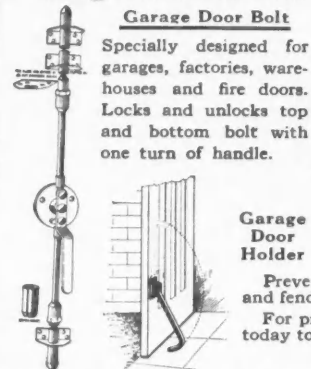

No. 50 Holder No. 52 22 Center Street Milwaukee, Wis.



#### Garage Door Holder

Prevents accidents, broken head lights and fenders. Operated by hand or foot. For prices and further information write today to

**Phenix Mfg. Co.**

## VENTA-LIGHT

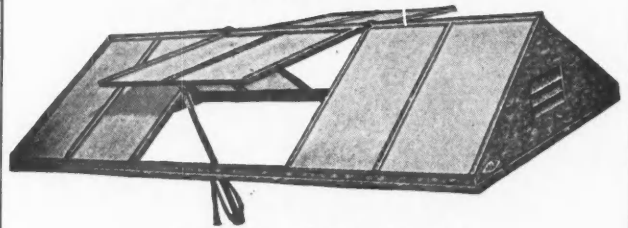

Type G. P. 2—uses Rope Operator

Venta-Lights are skylights whose sash open upward. They are the most efficient roof ventilators made. No operation cost. Easily erected by anyone. Write for Bulletin C-C 44.

**Messenger & Parks Mfg. Co.**  
Aurora, Illinois

## ORIGINATORS OF SASH CHAINS



MADE IN "GIANT METAL" (PHOSPHOR BRONZE) "RED METAL" (BRONZE) AND STEEL IN A VARIETY OF SIZES FOR DIFFERENT WEIGHT SASH. FAR SUPERIOR TO SASH CORD.

**THE SMITH & EGGE MFG. CO.**  
BRIDGEPORT, CONN.

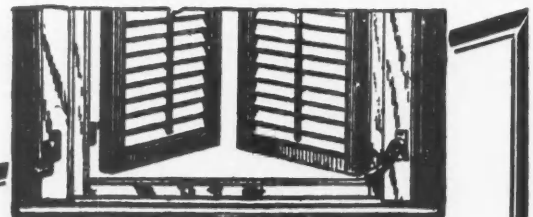

**JUST TURN THE HANDLE**  
**The MALLORY SHUTTER WORKER**

Operates from inside by a simple turn of the handle  
WRITE US FOR INFORMATION

**MALLORY MFG. CO.** 173 Bloomfield Avenue  
Plumington New Jersey



**Portable Electric  
Rip Saws—Band Saws—Swing Saws**

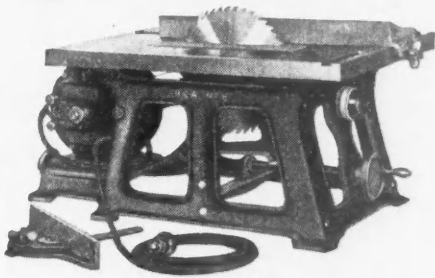

*Save Time,  
Power  
and Money*

Do away with  
hand work.

More satisfactory than  
any combination machine  
and all three cost  
but little more.

**Guaranteed  
Satisfactory**

*Circulars on Request*

**HESTON & ANDERSON, 107 S. Sixth St., Fairfield, Iowa**

**There Is No Better Machine Made Than the  
"Lightning Electric"  
Floor Surfacer**

If you are interested in Floor Surfacing Machines be sure to write for the literature on the "Lightning Electric"—the highest quality and most economically priced floor surfer on the market. Will do the work of six to eight men and do it better.

**No Old-Fashioned Side Roller**

The "Lightning Electric" will surface right up to quarter round without the use of the Old-Fashioned and cumbersome side roller. Leaves NO waves or chatter marks in the roughest floors—will NOT vibrate.

**Five Day Free Trial and Five Year Guarantee**

Write for our five day free trial and our five year guarantee on the best Floor Surfacing Machine the world has ever produced. Costs you nothing to investigate and the machine pays for itself the first month. A business making proposition for the contractor or individual—write today.

**National Sanding Machine Co.**

Formerly The Globe Mfg. & Dist. Co.

**Sales Office: 543 Vedder Street . . . Chicago, Illinois**



**THE FASTEST SAW RIGS  
IN THE WORLD**

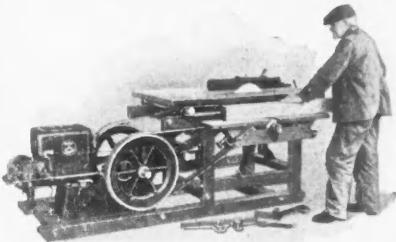

**NO OTHERS  
AS  
SPEEDY  
ACCURATE  
AND  
SIMPLE**

**BEACH MANUFACTURING CO.  
MONTROSE, PENNA.**

**The BACK SAVER**

For the use of Scrubbing,  
Waxing, Polishing, Sanding  
and Grinding floors of all  
kinds.

No Gears,  
Noise or  
Grease.



*Write for Prices*

**Ability Surfacing Machine Co.  
5 Woodworth St.  
Dorchester, Mass.**

**The American  
Sash Trimmer**

Is a handy machine for speeding  
up your production in the shop.  
This machine will save you much  
time and money in making

**Divided Light, Fancy Sash,  
French Doors, Screens,  
AND OTHER LIKE PRODUCTS**

We will gladly send you circulars  
and detailed information. Write  
for it at once.

**MANCO MFG. CO.  
BRADLEY ILLINOIS**

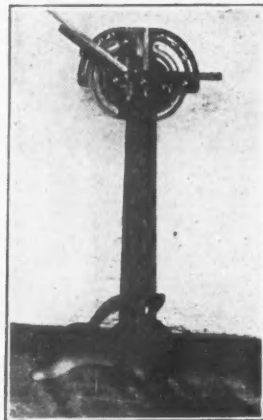

**Speed Up Your Work  
with the  
Racine Duplex Band Saw**

It's the only combination wood and  
metal cutting portable  
band saw for  
woodworkers, pat-  
tern shops, tool  
rooms, metal  
workers and con-  
tractors.

Can be attached to  
any light socket.  
Runs as smooth as  
a watch.

**Racine Tool & Machine Co.  
15th Street  
Racine, Wisconsin, U.S.A.  
"Standard the World Over"**



**Don't wait.  
Write today.**

Our circulars will  
be mailed you free  
of charge.

Send Us Your  
Address

**Look! Something You Have  
Been Waiting For!**

Electric Floor Sanding Machine that is practical for  
the small apartment house work.  
Lightest machine on the market,  
total weight 180 lbs. Only machine  
that can be operated from the ordinary  
5 amp. meter. Guaranteed to take up  
absolutely all the dust. Has the best equip-  
ment that can be bought in the market  
today. Check this up. C. E.  
or Wagner 40 degree motors,  
Morse silent chain drive,  
RIV ball bearings and 50 ft  
Royal rubber covered cable.  
Improved split sanding  
drum running 1450 R. P. M.  
300% saving on sandpaper.  
Latest, improved, up-to-  
date. Patented in U. S. and  
Canada, July, 1923. Special  
price, F. O. B. Factory,  
\$275.00. Fully guaranteed  
against defect in workman-  
ship or material.



Man'd by **CAMPBELL MACHINE CO., INC., 39 Hayward St., P. O. Atlantic, Mass.**

**BARNES  
Electric Bench  
Scroll Saw**

**Portable:—  
take it to  
the job!  
Weight 80 lbs.**

Will saw 2 inch  
Pine at 2½ feet per minute—2 inch Maple at 1½ feet per minute

Made by  
**W. F. & John Barnes Co.  
74 Ruby Street Rockford, Ill**



## CHICAGO

Chicago-Francis  
Interior Gas-Heated  
Clothes Dryers

*A size for every need*

We manufacture a complete line of laundry appliances.

Our engineering department is at your service. We help you plan the laundry. Free of charge. All inquiries will be given prompt and courteous attention.

Ask for our catalog

**Chicago Dryer Co.**  
2214 N. Crawford Ave.  
Chicago Illinois

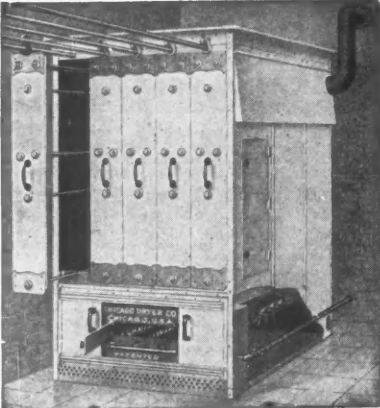



# BARTON TOOLS

**91 Years Successful Experience  
Guarantees D. R. Barton Tools**

Since 1832 D. R. Barton Tools have been giving their users a lifetime of constantly satisfactory service. Look for the name, D. R. Barton, stamped on the tools. It is your assurance of quality.

Manufactured by  
**Mack Tool Co., Inc.** West Commercial St.  
East Rochester, N.Y.

Machine Knives for planer, jointer and paper. Edged tools for manual training, pattern making, carving and carpenter.



## FORSTNER BITS

BRACE & MACHINE

THE FINEST Tool Manufactured for important wood work.

Specially adapted for Hardwood operations; indispensable to the High Class Carpenter and for Cabinet and Pattern Work.

Manufactured by  
**THE PROGRESSIVE MFG. CO.**  
TORRINGTON, CONN.

*Special Offer*

A sample bit up to 1 inch in diameter will be mailed postage prepaid, upon receipt of 75c to any woodworker or carpenter.



	23	22	21	20	19
LENGTH	OF COMMON	RAFTER	PER FOOT	RAFTER	PER FOOT
DIFFERENCE	OF HIP OR	VALLEY	16 INCHES	PER FOOT	RUN
	IN LENGTH	OF JACKS	2 FEET	CENTERS	RUN
FIGURES	GIVING	SIDE CUT	OF JACKS	OF HIP OR	VALLEY
		CUT OF	SHEATHING	IN VALLEY	OR HIP
22	21	20	19	18	17

THIS CUT SHOWS END OF BODY OF SQUARE

The Original and Most Complete Framing Square on the Market Today

We manufacture these in both Solid and Take-Down styles

Send for our LITTLE BOOK explaining this rule.

**NICHOLLS MFG. CO., Ottumwa, Iowa**

## THE GREAT BELL No. 42

NOTICE THIS →

New Baffle Plate Radiator

Introduced on this furnace means a non-clean-out radiator—the greatest improvement made on any furnace in twenty years. It eliminates the possibility of a clogged or choked radiator. No cleaning out is ever required.

We consider for size and weight that this furnace has no equal on the market today. We also make this pattern in a smaller size with a 20-inch fire pot.

Our line of pipe and pipeless furnaces is most complete.

Exceptional agency proposition to live-wire representatives in unoccupied territory.

Write at once

**The Bell Furnace & Mfg. Co.**  
Northville, Michigan



## A Mortise a Minute

The New  
**Electric Motor Machine**  
cuts any size mortise from round hole up to 6 inches.

**Light — Simple — Efficient**

Do your work with power instead of by hand.

We also manufacture a Hand Operated Machine

Full description and prices on request.

**PERFECTION MORTISER CO.**  
141 N. Water St., COLUMBUS, OHIO

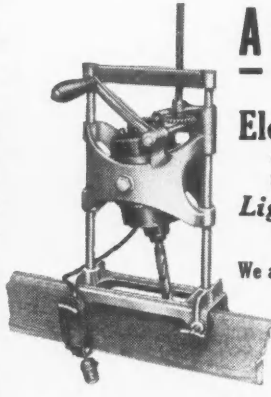

For Stores, Offices and Homes

## Hopson Metal Ceilings and Sides

Tasty, dignified designs, characterize Hopson Metal Ceilings and Sides. They're all easy to match and install. Our pictorial catalogue will show what we have to offer in original designs. Get a copy today.

W. C. HOPSON CO.  
704 Ellsworth Ave., Grand Rapids, Mich.

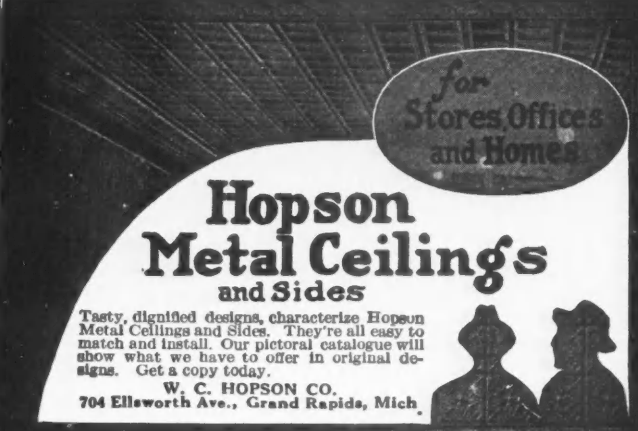

## Waterproof— Durable— Permanent—

No other material made can equal Con-Ser-Tex Canvas Roofing for covering floors, sleeping porches, roof gardens and outside flat surfaces. Chemically treated so it will not leak; rot-proof and mildew-proof. Handsome in appearance. Laid easily and quickly.

Handsome new booklet "Roofing Facts and Figures"—B, containing interesting facts regarding canvas roofing sent free on request. Write for your copy.

**WM. L. BARRELL CO. of N. Y., Inc.**  
50 Leonard Street  
New York City

Chicago Distributors:  
Geo. B. Carpenter & Co.  
430-440 North Wells St.

California Distributors:  
Waterhouse-Wilcox Co.  
San Francisco and Los Angeles

# CON-SER-TEX CANVAS ROOFING

## Moderately Priced



The New **MAJESTIC** STEEL IRONING BOARD CABINET

Fits into any 2" tile or Pyrobar wall, or any 2" x 3" or 2" x 4" stud wall.

Saves from \$1 to \$5 over the cost of an ordinary wooden cabinet, installed, trimmed and finished. Reaches building complete with six screws, no trimming required.

An Outstanding Value. Heavy furniture steel, nickelplated hinges and latches. Snugly fitting, dustproof doors. Durable baked finishes in sparkling white, gray, grained walnut or grained mahogany. Write for prices. Our engineering department is at your service without obligation.

MAJESTIC STEEL CABINET CO.  
4211 Belle Plaine Ave., Chicago  
"Household Steel Cabinet Headquarters"

## Black Bros. Clamps

(Recognized standard of quality)

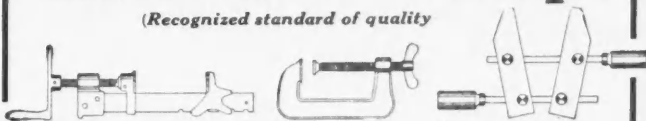

Made for every branch of woodworking and many other uses. Powerful, durable and convenient. Made by one of the largest and best equipped makers of glue room machinery, and sold by good hardware and machinery supply houses everywhere. Catalog 12 sent on request.

Manufactured by

**THE BLACK BROS. CO., Inc.**  
Mendota, Ill.

Mfrs.—Clamps, clamp carriers, veneer presses, glue room equipment, etc., etc.



## "STANDARD" MAIL BOXES

Insures Safety of Mail

A quality product, at prices that will interest you.

The most complete line manufactured

Pat. Applied for

Made with—  
CAST BRASS FRONT AND DOORS  
SHEET BRASS FRONT AND DOORS  
SHEET STEEL FRONT AND DOORS "BRASS FINISH"

Approved by U. S. Post Office Department.

**THE box that gives Satisfaction.**

Write for prices and territorial rights.

**STANDARD SALES AND MFG. CO.**  
103 PARK AVE., NEW YORK DEPT. A

## Black Bros. Clamps

(Recognized standard of quality)

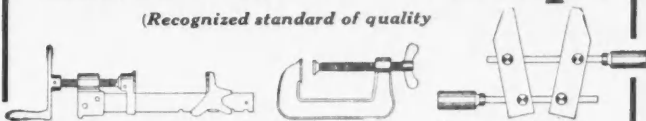

Made for every branch of woodworking and many other uses. Powerful, durable and convenient. Made by one of the largest and best equipped makers of glue room machinery, and sold by good hardware and machinery supply houses everywhere. Catalog 12 sent on request.

Manufactured by

**THE BLACK BROS. CO., Inc.**  
Mendota, Ill.

Mfrs.—Clamps, clamp carriers, veneer presses, glue room equipment, etc., etc.

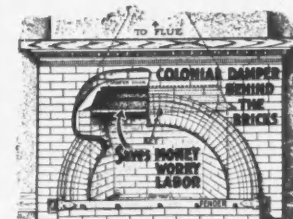

## Make Your Fireplace Genuine

AVOID SUBSTITUTES, Use Only the ORIGINAL

## COLONIAL HEAD-THROAT AND DAMPER

No smoking, perfect draft control, insures correct construction of the fireplace throat—the most vital part. With the Colonial Head and our FREE plans you can be sure your contractor will build right. Write for FREE book. Also blue print showing common mistakes in fireplaces.

Colonial Heads, in four styles of 12 sizes each at \$5.00 and up, meet every condition in fireplace construction. At your dealer or write us. Also manufacturers of Complete Fireplaces, Dampers, Grates, Andirons, Screens, Fenders, Hoods, Firesets, etc.

COLONIAL FIREPLACE COMPANY :: 4604 Roosevelt Road :: Chicago, Illinois

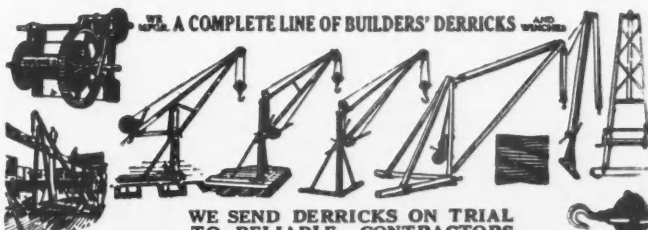

A COMPLETE LINE OF BUILDERS' DERRICKS

WE SEND DERRICKS ON TRIAL TO RELIABLE CONTRACTORS

Our Motto is SATISFACTION or DERRICK RETURNED

Write for circular No. 2 with illustrations, descriptions and best prices on our complete line. Sagen Builders' Derricks are built of the best Crucible Steel and Malleable Iron Fittings which makes them light, strong, safe and durable. The derricks will please you, and probably more than pay for themselves on the first job. Get one on trial.

**SAGEN DERRICK CO.,** 3161-3125 W. GRAND AVE. CHICAGO, ILL.  
NEW YORK OFFICE—130 West 42nd St.

## IRON RAILINGS FOR EVERY PURPOSE

Plain and ornamental iron fence—entrance gates, wire and iron window guards, folding gates, gratings, cellar doors, etc. Catalog on request—estimates cheerfully given—orders filled promptly.

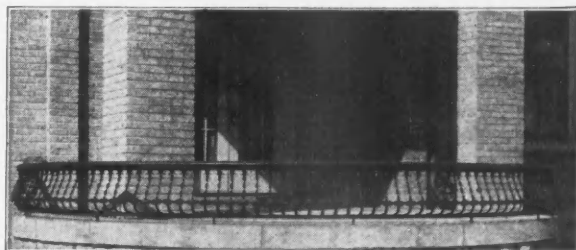

**CINCINNATI IRON FENCE CO., Inc.**  
3331 Spring Grove Ave., CINCINNATI, OHIO

## Builders! Free Plan Sheets

Make your suburban buildings more salable, more valuable by using

### San-Equip Septic Tanks and Self-Drain Toilets



San-Equip Septics provide safe easy sewage disposal for water-plumbing. Rust-proof copperoid iron tanks—correct design, water-tight, unbreakable, ready to connect.

—Or for the home or camp without water, use San-Equip Self-Drain Toilets. China bowl and storage tank, safe, sanitary; no valves or pumps.

We ship for free inspection from warehouse nearest you.  
**Chemical Toilet Corp.** \$44.00 up. Pat. Pending  
2612 Liverpool Rd. Syracuse, N. Y.

San-Equip Septic Home Size \$52.00

New Self-Drain Toilet.

Now Only \$44.00 up. Pat. Pending

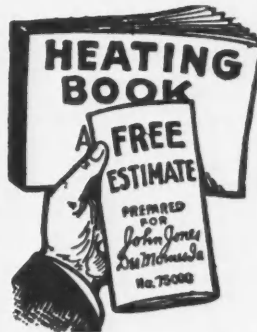

## Ask for Agency Offer and Catalog

All Kinds of Heating—Hot Water—Steam—Hot Air—Pipeless—Pipe—Sewage Disposal—Water Supply—Plumbing—Low Prices.

**ANDREWS HEATING CO.**  
1500 Heating Bldg. MINNEAPOLIS, MINN.

**ANDREWS HEATING COMPANY**  
Please Send Catalog and Agents Offer  
Name.....  
Address.....  
Town.....  
State.....



**IDEAL WINDOW SASH SUPPORTER**  
*The Economical and Positive Method of Window Sash Support*



Mr. Builder, investigate this modern and better method of supporting windows. They will increase your profits—makes a warmer home—keeps out cold and dust. Stops binding and rattling windows easily installed on old or new houses. Write for full details or order through your dealer or direct.

Single Sets Post Paid \$1.00  
 West of Rockies \$1.75. Canada \$2.00

**IDEAL SASH SUPPORTER COMPANY**  
 KINGSTON, PA.

**ABC ← Weatherstrips → ABC**  
**All Always Brings Comfort**  
**ABC ← Weatherstrips → ABC**

ABC Weatherstrips are economical and durable. Are installed without removing the sash. Any carpenter can install them. Endorsed by leading architects, owners and builders. Send us the measurements, and we will furnish an estimate free.

**HOFFBAUER COMPANY, Inc.**  
 Telephone: Murray Hill 5374 101 Park Avenue, New York City

**PUMPS**

**A Type for Every Service.**  
**Catalogs and Bulletins on request**

**THE GOULDS MANUFACTURING COMPANY**  
 SENECA FALLS, N. Y.

**GOULDS**

Want to be Independent?



Are you progressive enough to want to be in business for yourself? If you are, we want you to handle Federal Metal Weatherstrips in your town.

Federal Weatherstrips give a service that every home owner will quickly recognize. Sales possibilities are almost limitless. Don't let the other fellow beat you to it.

Write us today and we will send you our generous agency proposition.

**Federal Metal Weather Strip Co**  
 1228-50 Fullerton Ave. Chicago, Ill.

**Hennen's Elastic Calking Paste**



Seals ALL joints AIR, DUST and water-proof, saves FUEL, prevents disfigurement of DECORATING, decay of SILLS and deterioration of MASONRY under windows.

Write for information and Prices

**WEATHERPROOF CALKING CO.**  
 758 Washington Ave., No. MINNEAPOLIS, MINN.

**THE HOMER COAL CHUTE**



A New Idea with a Practical Door Lock  
 Homer Fireplace Dome Dampers  
 Homer Chimney Cleanout Doors  
 Homer Fireplace Ash Traps

**HOMER FIREPLACE BASKET GRATES**

Homer Andirons  
 Homer Fireplace Spark Guards  
 Homer Fireplace Tool Sets  
 Our line is complete, quality guaranteed

**HOMER FURNACE CO.**  
 COLDWATER, MICHIGAN - - U. S. A.

**C. G. Hussey & Co.**  
 Pittsburgh, Penna.  
 Manufacturers of

**COPPER** in { **Sheets Plates Rolls**



Copper Nails Eaves Shoes Soldering  
 Copper Rivets Copper Troughs Mitres Coppers  
 Conductor Pipe Elbows Gaskets Etc.  
 Corrugated Copper Conductor Pipe

Member Copper and Brass Research Association.

**PLANS for HOMES**



Let these Books be your Guide. Beautiful California Styles, with Pictures and Plans for all-climate homes.

"All-American Homes"  
 50 Houses—7 to 10 Rooms. . . . \$1.

"The New Colonials"  
 50 Houses—6 to 10 Rooms. . . . \$1.

"South-West Stucco Homes"  
 75 Bungalows and Duplexes. . . . \$1.

"West Coast Bungalows"  
 60 Houses—6 and 7 Rooms. . . . \$1.

"Little Bungalows"  
 75 House—3, 4 and 5 Rooms. . . . \$1.

**SPECIAL OFFER:**  
 Send \$2.50 for any three books and Garage Folder.  
 Books and Blueprints sold with Money-Back Guarantee

**E. W. STILLWELL & CO., Architects, 203 Calif. Bldg., Los Angeles**

**HALL OCTAGON LINE & SURFACE LEVEL**  
 MADE OF ALUMINUM ACCURATE - RELIABLE PATENTED FEB. 22, 1921  
 WT. 1/2 OZ.

USED ON A LINE  
 ATTACHMENT FOR SQUARE  
 USED FOR PLUMBING

USED AS A STRAIGHT EDGE

Each level and attachment put up in a metal case.  
 If your dealer cannot supply—sent for 75¢ Post Paid.

**FRANK B. HALL** Geneva, Ohio.

**QUICK ACTING SELF LOCKING**  
*The Taylor*  
**CLAMPS** An Investment Not An Expense

Quickest and strongest clamps made. Standard in U. S. Government Works and in such concerns as General Electric Co., Singer Sewing Machine Co., Victor Talking Machine Co., etc. We can prove it in your own shop. Write today.

**JAMES L. TAYLOR MFG. CO.,** Poughkeepsie, N. Y.

**FLEXO-CRETE**

Make water-proof building blocks in Flexible Moulds.

Others are doing it, why not you?

Write for booklet and prices

**FLEXO-CONCRETE MOLD CO.**  
 815 Vernal St.  
 CEDAR RAPIDS, IOWA

**Imperial Sanitary Floor**

Put on like Plaster  
 Wears like Iron  
 -waterproof  
 fireproof  
 resilient  
 noiseless  
 dust-less

Base and Floor one solid piece

A composition material easily applied in plastic form over practically any kind of floor. Laid about 3/8 inch thick. Imperial floor does not crack, peel or come loose from foundation. A continuous fine grained, smooth, non-slipping surface. No crevices to gather grease, dirt, dust, disease germs or moisture.

Ideal Floor for Kitchen, Pantry, Bath Room, Laundry, Porch, Garage, Restaurant, Theatre, Hotel, Factory, Office Building, Railroad Station, Hospital—Wherever a beautiful substantial floor is desired. Several practical colors. Full information and sample FREE of your first and second choice of colors.

**IMPERIAL FLOOR CO.,** 373-375 Halstead St., Rochester, N. Y.  
 A Success for 15 Years

**SHELDON Mixers**

TRAILER No. 3

CONTRACTORS NAME PRINTED HERE

Sheldon Mixers are being used more and more by Contractors everywhere to SAVE MONEY for them on work where the cost of transportation and operation of large mixer is too great.

The New SHELDON ALL-STEEL reversible tilting dump mixers, on skids or Two-wheel rubber tire trailer, are priced from \$45 to \$195. Capacity 3 1/2 cu. ft. Get specifications and full information on our complete line of 19 outfits; priced from \$14.20 to \$197.50 f. o. b. factory.

WRITE TODAY

**THE SHELDON MFG. CO. Inc.,** Box 1005, Nehawka, Neb.

**Misplaced Buildings!**

Every town and city has its quota of misplaced frame buildings—old houses and store buildings that now occupy expensive locations. These buildings can be moved to less expensive locations so that the owners may realize a revenue in keeping with the total value of the respective properties.

**LaPlant-Choate Moving Equipment** is the means of safely and profitably moving old frame buildings from one location to another. LaPlant-Choate House Moving Trucks facilitate speed and insure safety in moving. They are made of Bessemer Steel. They'll stand up under gruelling service. Oscillating feature eliminates racking of building. Hundreds of moving contractors are now using LaPlant-Choate Equipment—and making big money! You can do the same. Write for Free Catalog.

**LAPLANT-CHOATE MFG. CO.**  
 3118 First Avenue, Cedar Rapids, Iowa  
 All-Steel, Made for Long Service.

**METAFORMS**  
 —for all Class of Work

Metaforms will practically eliminate lumber bills for forms. They are adaptable to walls of almost any shape, size or thickness.

They can be erected quickly by unskilled labor. Use Metaforms for all concrete work. They will cut the cost of construction and increase your profits.

Write for complete descriptive matter.  
 It's yours for the asking.

**METAL FORMS CORPORATION**  
 MILWAUKEE WISCONSIN

**FEBRISCO**

**Welded Solid Steel Sash**

For basement windows give permanent satisfaction.  
 Made in four standard sizes.

2 light.....	12 x 20
3 light.....	10 x 12
3 light.....	10 x 16
3 light.....	10 x 20

We also manufacture welded solid steel Industrial Sash, Projected Ventilator Sash, Store Front and Show Windows and Skylights.

Catalog furnished on request.

**Federal Steel Sash Co.**  
 Waukesha, Wisconsin

**ECONOMICAL  
NO DELAY  
NO RISK**

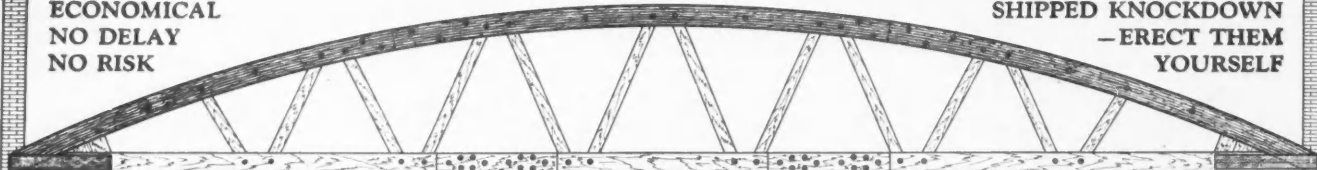

**SHIPPED KNOCKDOWN  
— ERECT THEM  
YOURSELF**

21 East 40th Street  
NEW YORK

Factory-Built Wood Bowstring Trusses  
**McKEOWN BROS. COMPANY**

112 West Adams Street  
CHICAGO

**LIVING-STONE**

**The Perfect Bond  
for Concrete**

Contains no acid. Therefore cannot injure concrete or steel. Forms a bond stronger than the concrete itself.

Catalog on request  
**LIVING-STONE CO.**  
OUR TRADE MARK SINCE 1905 1 E. Lee Street, Baltimore, Md.

**MORRILL SAWSETS**

Set Saws Just Right

"Saw Points" telling you "How to Joint, Set and File Saws" sent free upon request.



**CHAS. MORRILL, INC., 98 Lafayette St., NEW YORK**

**USE  
CALDWELL SASH BALANCES**

Thirty-five years of service is assurance of quality

**CALDWELL MFG. CO.**  
15 Jones Street Rochester, N. Y.



**The Advantages of**

No. 27 Hauser Adjustable Screen and Storm Sash Hangers for Half and Full Size Screens.

By using Hauser Hangers your screens will fit tight against stops which makes them insect proof. You save 25% on lumber and labor.

Prices, Samples and Catalogues sent on request.  
**MARTIN HAUSER MFG. CO.**  
413 Prescott Street Toledo, Ohio



**DECORITE**  
*For Walls of Character*

Economical and simple material for obtaining all wall textures.

**THE DECORITE CO. 159 Harvard St. Cambridge, Mass.**

**MORENE** *The Wall Finish  
Distinctive*

(A Portland Cement Product)

See pages 60-61 June Number

**249 West 28th St. New York**

**STEVENS LINE AND SURFACE LEVEL**

Made of Aluminum **Wt. 1/2 oz.**

Write for Circular and Prices. Ask your Hardware Dealer.  
**E. A. STEVENS & SON** Newton Falls, O.



**INDESTRUCTO CARPENTER'S  
TOOL CASES**

Made of three-ply Veneer with canvass, painted and varnished, waterproof, light and strong. Secure locks, strong handle, place for every tool, carried like suitcase.

Write or booklet and prices  
**WEDELL & BOERS**  
28 West Jefferson Ave. Detroit, Mich.



**A Pocket-book that Fits the Pocket**  
**"BUILDING LABOR CALCULATOR"**

consists of unit tables giving accurate constants for every building job—material quantities and labor hours.

A time and money saver on every estimate.

For sample pages, descriptive folder and free examination offer, slip this ad and write:—  
**GORDON M. TAMBLYN, Gen'l Contractor, No. 8, Sweeney Bldg., Denver, Colo.**

**The Most Economical Sash Holder**  
**It Is Automatic**

No Sash weights, cords, pulleys or balances necessary.

Write for Prices  **Send For Trial Set \$1.25 Prepaid**

**HARDWARE SALES CO., 30 Church St., Room 446E, NEW YORK CITY**

**"LIGHTING FIXTURES"**  
**READY TO HANG**

Direct from manufacturer. Completely wired including glassware. Send for Catalogue No. 26 (just off the press). *Special proposition to dealers.*

**ERIE FIXTURE SUPPLY CO.**  
Station B ERIE, PA.



**PROFITABLE BUILD YOUR OWN  
'SPARE GRANDFATHER'S CLOCK  
TIME WITH OUR HELP**

We furnish blue prints, finishing material and instructions. Buy the works, dial, weights and pendulum from us at surprisingly low prices. You make a fine profit building artistic clocks for your friends. Complete Works \$5.00. Others with Chimes at all prices. Ask for our attractive Free Offer.

**AMERICAN CLOCK CO., 1643 Ruffner St., Philadelphia, Pa.**



**INVESTIGATE**



**The Remarkable Feature  
One Piece—Pressed Steel**

**SOMETHING NEW SOMETHING DIFFERENT**  
**SAVAGE EXPANSION SHIELD**

**Economical—Novel Type Pressed Steel—Efficient**

Widely used on important government work and other large building operations

Let us send you samples and prices. Prompt deliveries

**SAVAGE EXPANSION BOLT CORP. 12 Desbrosses Street, New York**  
**THE ORIGINATORS OF PRESSED STEEL EXPANSION SHIELDS**



**Plumbing, Heating and Pneumatic Waterworks Supplies at Wholesale**

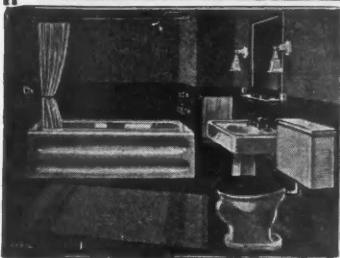

When in the market for Plumbing, Heating and Pneumatic Waterworks Supplies and you wish to **Save 20 to 40% ON EVERY ARTICLE ORDER FROM US** Small orders are as carefully handled as large ones. Only house selling guaranteed plumbing and heating supplies to all. Send for Catalog

**B. KAROL & SONS CO., 806 South Kedzie Ave., Chicago, Ill.**

**The EASY CHANGE**  
Combination Storm and Screen Door



**2 IN 1**

If your dealer can't supply you, write us and send his name.

**COMBINATION DOOR COMPANY**  
FOND DU LAC - WIS.

**BUILT-IN WOODWORK**

Adds the touch of Refinement. Beauty that increases renting and selling values.

**SEE OUR OFFERS**

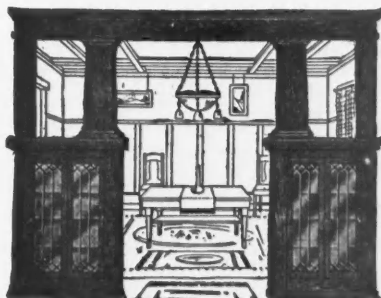

Bookcase Colonnades—Sideboards, Medicine Cabinets, etc., are of Distinctive Design and give living comfort to any home.

**BERTELSEN ADJUSTABLE GRILLE CO.**  
2119 South Troy Street, CHICAGO

Send for Free Catalog

**SAMSON SPOT SASH CORD**

**MADE** of extra quality stock, carefully inspected, and guaranteed free from imperfections of braid or finish. No loaded centre to increase weight and decrease wear.

SEND FOR CATALOG AND SAMPLES

**SAMSON CORDAGE WORKS**  
BOSTON, MASS., U. S. A.

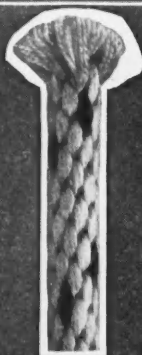

TRADE-MARK  
REG. U. S.  
PAT. OFF.

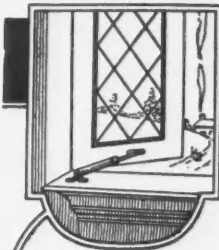

**LYMCO**

**CASEMENT WINDOW ADJUSTER**

IT is made simple because the women are the ones who must use it. Just a turn of the thumb nut and the window is firmly gripped. A reverse turn releases it. Its simplicity more than anything else accounts for its nation wide use.

Brass throughout so it will not rust. Made in several popular finishes.

The Lyons Mfg. Co. New Haven, Conn

WRITE FOR PARTICULARS AND PRICES



Formerly sold under the name "Interlock"



**TAKE THIS MACHINE TO YOUR JOB IT IS REALLY PORTABLE.**

Full 1/2 H. P. Motor can be operated from any lamp socket.

One local contractor just advises that his UNION combination is saving over eight dollars a day.

Bulletin on Request

**Gallmeyer & Livingston Co.**  
396 Straight Ave., S. W.  
GRAND RAPIDS, MICH.

**J. M. WATERSTON**  
423 Woodward Ave. DETROIT, MICH.

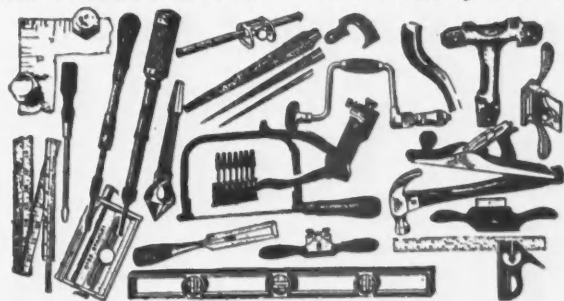

I SPECIALIZE IN TOOLS

Send for Free Catalogue No. 24

**MASTER FOLDING RULE**

With Concealed Solid Brass Joint

Strongest, most durable folding rule made. Wooden sections are not weakened by boring at ends to fit on clamps. Grinding absolutely eliminated. No springs to rust. Write for circular.

We also make the "Interlox" Master Slide Rule, for all difficult inside and outside measuring. All lengths, from 2 to 8 feet. Finest box-wood. If your dealer cannot supply, send for one at 20c per lineal foot.

**MASTER RULE MANUFACTURING COMPANY**  
(Formerly Dahl Mfg. Company)

821 East 136 Street

New York City

# Classified Advertising

## Business Opportunities

## For Sale and Exchange

## Help and Situations Wanted

**FOR SALE**

USED TRANSITS and LEVELS. Write for list. BUFF, Hudson Terminal Building, New York City.

FOR SALE—Concrete building block machines, steel molds for concrete burial vaults, etc. Catalog free. CONCRETE MACHINERY CO., 303 S. Third St., St. Louis, Mo.

TIME SHEETS, JOB TICKETS, ESTIMATING BLANKS, ILLUSTRATED STATIONERY, etc., for carpenters and builders. Large and small lots; reasonable. Prompt service. Samples and prices free. L. FINK & SONS CO., Inc., Elm Avenue, Laurel Springs, N. J.

CARPENTERS, CONTRACTORS, BUILDERS, ETC.—Send for our Free Booklet, "How to Read Blue Prints." Tells how to make most money in the building trades. Every builder should have this information. Write today. Address: Dept. 2346, CHICAGO TECH., 118 East 26th St., Chicago, Ill.

LIGHTNING RODS—Dealers who are selling lightning protection will make money by writing to us for our latest factory to dealer prices. We employ no salesmen and save you all overhead charges. Our pure copper cable is endorsed by the mutual insurance companies and the National Board of Fire Underwriters. Write today for samples and prices. L. W. DIDDIE COMPANY, Marshfield, Wis.

PATENT PROCURED. Prompt service. PERSONAL CAREFUL AND EFFICIENT SERVICE. Highest references. Moderate fees. Send sketch and model for actual reach and advice. GEORGE P. KIMMEL, Master of Patent Law, 94-D, Loan & Trust Bldg., Washington, D. C.

C. L. PARKER, PATENT ATTORNEY. Formerly member Examining Corps. U. S. Patent Office. McGill Bldg., Washington, D. C. Pamphlet of instruction sent upon request.

PATENTS—Booklet free. Highest references. Best results. Promptness assured. WATSON E. COLEMAN, Patent Lawyer, 644 G St., Washington, D. C.

BUILDERS: Here is a chance to learn how to draw plans for buildings. Your spare time at home is enough. We furnish tools. Send for our "Free Trial Lesson in Drawing." Address: Dept. 2660, CHI. TECH., 118 East 26th St., Chicago, Ill.

AUTO TRAILERS \$39.00, bargain price, direct from biggest manufacturer, light weight, ½-ton capacity, best automobile construction, just the thing for contractors, builders and carpenters for hauling materials, tools, concrete mixers, and woodworkers, can be hitched to your truck or automobile, hundreds all ready in use. Write at once for catalogue. BOWER MFG. CO., Box 10, Fowler, Ind.

WILL sell almost complete set of wood working machinery, planers, jointers, etc. S. S. WESTVOLD, Eagle Grove, Ia.

GET a big start in life for the man with the small income. I will instruct you in the following, how to stop paying rent, how to build your home without borrowing any money; have had 37 years experience in the building trades. For particulars write: JAMES J. J. EASTMAN dealer in real estate, general contractor and builder, R. D. No. 5, Youngstown, Ohio.

## HOTEL CHASE

LINDELL BOULEVARD AND KINGSHIGHWAY ST. LOUIS, MO.

Situated in the most exclusive district in St. Louis, yet only 10 minutes from the city's business, theatre, and shopping centers. The Hotel Chase serves both permanent and transient guests. Excellent cuisine—table d'hôte and a la carte service. At the entrance to Forest Park, the playground of St. Louis. Roof Garden open June to September. Accommodations for 1,000 guests with reasonable rates of from \$3.50 per day, and up, with bath. Garage in connection. Motorbus and street-car service direct to the hotel.

FREDERIC C. SKILLMAN GEORGE T. THOMPSON  
MANAGING DIRECTORS

Set solid, minimum 20 words - - - - \$2.00  
Each additional word, 10 cents  
All capitals, minimum 20 words - - - - \$5.00  
Each additional word, 15 cents

It is Necessary That Remittance Be Sent with Orders.

PHOTOS of furniture with the sizes and shapes taken on them, \$0.75 per dozen. W. E. RODICK, Bar Harbor, Me.

CARPENTERS—The Handy Rafter Table gives exact length, common, hip, valley, jack rafters, any pitch roof, any size house. \$1.00 prepaid. G. R. BICK, 2651 Grape St., Denver, Colo.

## ONE MAN CAN RUN IT

**The Little Whirlwind Concrete Mixer**  
**THE MASTER MIXER**  
From Factory to You—Save 40%



Only \$59.50

432 Gould Street  
La Crosse, Wisconsin

PHOTO: Only real practical small mixer producing same perfect work as most expensive big machine. Complete with hand and power drive. A winner for the contractor or cement worker. All steel and iron. Just like the big \$500 mixers, only simpler. Just the size you need at a price you'd like to pay. Does your work in one-fifth time.

PHOTO: The Whirlwind Way Makes Mixing Pay  
Saves its cost on one job. Capacity about 3 cubic ft. Mixes a batch a minute. Does PERFECT work, wet or dry, empties clean. Discharges direct to forms, cuts out the wheeling and backache. Satisfaction guaranteed or your MONEY BACK. Reference: Any La Crosse, bank or Dun Agency. Write for circular or order direct from this adv. and avoid delays.

## 8 MEN CANT STICK IT

**Make Your Basements Water Tight**  
by using Bitu-Mortar Waterproofing Compound, Liquid, for waterproofing cement coatings. Inexpensive and everlasting.  
Write for our catalog.

The Bitu-Mortar Waterproofing Co., Inc.

Engineers  
Contractors and  
Manufacturers

**BITU-MORTAR**  
WATERPROOFING  
WATERPROOF PERMANENTLY

280 Madison Avenue, New York, N.Y.

**Drip Edge, The Best Edge**  
for fastening and finishing prepared roofings and shingles edges at the roof edges.



CROSS SECTION OF EAVE

ROOFING OR FIRST LAYER OF COMPOSITION SHINGLES

D RIP E D G E

MILLER & GLEASON, Div. D, Olean, N. Y.

PHOTO: O. L. Sison of Great Bend, N. Y., writes without our asking, "It is the best edge I ever saw." J. A. Truesdell of Bluemont, Va., says, "It is all you say it is." Your dealer should have it if he has not doop us a card.

**FASTER · SHINGLING — MORE MONEY**  
Carpenters and Builders! That's what it means when you use the



**SAYRE**  
Shingling Hatchet  
With positive gauge—Get one today!

Gauge is positive—cannot slip, clamps on with screw—is readily changed. Unequaled for fast shingling; ask for No. 144 (made with oval head, 169 points) price, postpaid \$3.00. Also with flat head, No. 44, 81 points, milled. Price \$3.00 postpaid.

L. A. Sayre Company, 334 Mulberry St., Newark, N. J.

.00

.00

em,

th,  
ise.

r

y  
r-d  
r  
st  
st  
y.

t.  
s.  
s.  
k

.

[Empty rectangular box]

[Empty rectangular box]

y  
.

W  
L  
P  
B