

FEBRUARY 1914

AMERICAN CARPENTER AND BUILDER



THE WORLD'S GREATEST BUILDING PAPER

IN
THIS
ISSUE

1914 BUILDING BUSINESS FORECAST—BETTER

CONCRETE WORK
IN FREEZING WEATHER

PROGRESS at the
PANAMA-PACIFIC FAIR

MODEL PRACTICAL HOME DESIGNS



HOW BUILDERS HAVE WON SUCCESS



DETAILS OF STOCK TERRA COTTA WORK

APPROVED CONSTRUCTION
METHODS



READERS' FORUM
QUESTIONS & ANSWERS

Price 20 Cents

Buy Saws with a Reputation Back of Them

☞ The Tools you use have much to do with your reputation as a fine, expert mechanic. You certainly cannot do the finest work, unless you have tools of the very latest pattern—that add speed, ease and accuracy.

☞ The next time you buy a saw, why not look at the latest and most approved design. Compare the hang, the quality of steel, the grinding and general construction and satisfy yourself that you are getting the most for your money.

☞ Ask to see **Atkins** No. 53, 68 or 400 Skew Back Saws, or **Atkins** No. 65, 69 or 400 Straight Backs. These are splendid types of the up-to-date Saw with Atkins Perfection Handle.

☞ Or if you want the old-style handle, ask for **Atkins** No. 51, 52 or 66 Skew Back, or 54, 64 or 67 Straight Back. These saws bear the maker's name and will give you satisfaction.



Splendid Types of Up-to-date Saws

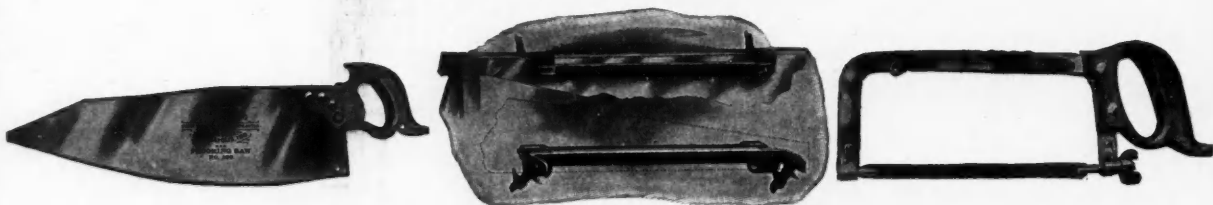

We Make a Perfect Saw for Every Purpose

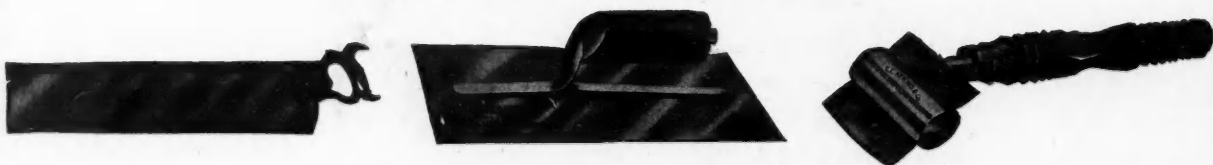

Try Atkins Special Saws and Tools

ATKINS *SILVER* *STEEL* SAWS

☞ Your regular dealer will be glad to order for you any Atkins Saw you may select. He has our catalog or can easily get one. Most likely he has in stock the very saw you want.

☞ If this matter of fine saws is of any interest to you, you have a right to get what you want, and if you want to try an **Atkins Silver Steel Saw**, see that your dealer supplies you and take no other. If he won't—then write to the address below.

E. C. ATKINS & CO., Inc.

The Silver Steel Saw People

INDIANAPOLIS, INDIANA

You will get SPECIAL ATTENTION if you tell Advertisers you read American Carpenter and Builder.

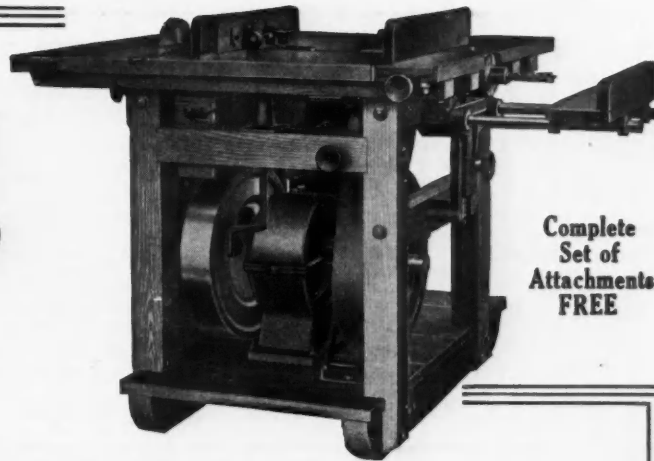

Complete
Set of
Attachments
FREE

EVEREADY SAW RIG

Here's [the **experienced**—money-saving—way! A brainy, time and labor saver for wise men, who are looking for the shortest cut to results.

The OSHKOSH EVEREADY SAW RIG Saves **six men's work**—mark that well. Besides cross-cutting and rip-sawing, this mechanical wonder-worker joints, sands, jig-saws, grooves, bores, miters, and grinds tools.

Can you **beat** it? Can you **equal** it—anywhere? Then why not get an "EVEREADY" RIG and cut down your production cost? A dollar **saved**—this way—is **more** than a dollar **earned**; it comes easier.

The sooner you start the "EVEREADY" going, the sooner you will begin to wonder how you ever got along without it.



Branch Dealers in Saw Rigs and Mixers

MIXER

This is the Mixer that sets the pace; the result of many years' practical experience of men who know the "mixing game" from A to Z.

Send for All the Facts!

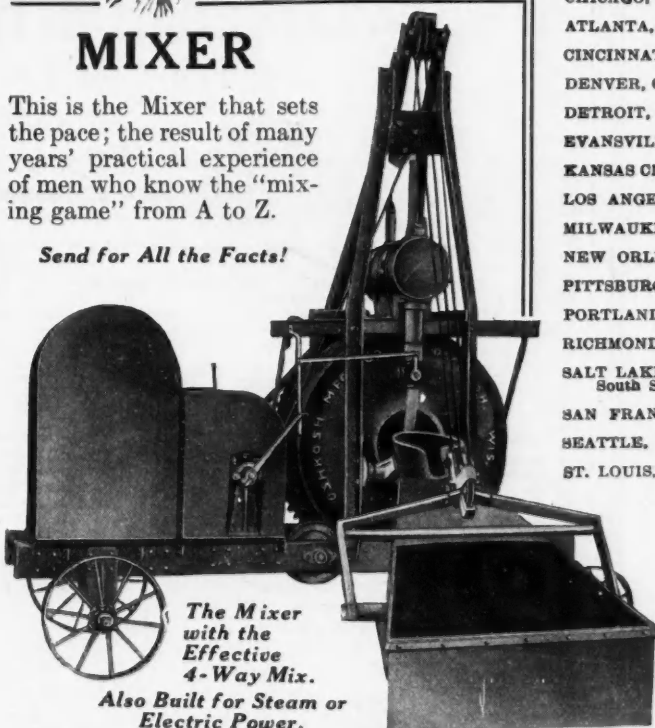

The Mixer
with the
Effective
4-Way Mix.

Also Built for Steam or
Electric Power.

- CHICAGO, 1452 Monadnock Block
- ATLANTA, GA., SOUTHERN SALES OFFICE, 604 Walton Bldg.
- CINCINNATI, OHIO, S. O. Holder Supply Co., 1128 Gilbert Ave.
- DENVER, COL., Geo. W. Summers & Co., 355 Railway Exchange.
- DETROIT, MICH., Claude Wadsworth, Jr., 963 Woodward Ave.
- EVANSVILLE, IND., Indiana Builders Supply Co., Furniture Exchange Bldg.
- KANSAS CITY, MO., King supply Company, 1201 Scarritt Bldg.
- LOS ANGELES, CAL., Arthur E. Banks, 1006 Wright & Callendar Bldg.
- MILWAUKEE, WIS., W. A. Lewis Company, 503 Merrill Bldg.
- NEW ORLEANS, LA., Henry J. Malochee, 802 Perrin Bldg.
- PITTSBURGH, PA., F. W. Patterson's Sons, 326 Diamond St.
- PORTLAND, ORE., G. A. Saunders, Builders Exchange, Second and Adler
- RICHMOND, VA., I. Bluford & Company, 1528 East Cary Street.
- SALT LAKE CITY, UTAH, F. C. Richmond Mch. Co., 117-119 West Second South St.
- SAN FRANCISCO, CAL., J. E. Dwan & Co., 445-447 Turk St.
- SEATTLE, WASH., Harold G. Stern & Co., 524 First Ave., South.
- ST. LOUIS, MO., C. O. Fisher & Co., 512 Liggett Bldg.

SAW RIGS EXCLUSIVELY

- PHILADELPHIA, Dodge & Dodge, 118 Maplewood St.
- ST. PAUL, MINN., Raymer Hardware Co., 373 Roberts St.
- OMAHA, NEB., Sunderland Mch. & Supply Co.

*Live Agents Wanted in
Open Territory*

OSHKOSH MFG. CO., 316 South Main St., OSHKOSH, WIS., U.S.A.

See Us at the Cement Show

You will get SPECIAL ATTENTION if you tell Advertisers you read American Carpenter and Builder.

FOR SURFACING AND POLISHING HARDWOOD FLOORS
The American Floor Surfacing Machine

IS NO EXPERIMENT. Its work since 1903 has established a standard for finely surfaced and polished floors. It is the only machine whose work is specified by leading architects and used in the best government buildings and will surface and polish any kind of a floor from common pine to finest parquetry.

IT IS THE ORIGINAL and only two-roll, self-propelled, dust-collecting machine, that surfaces close to the wall and can be used in small rooms. Anyone can operate it.

ITS WORK IS RAPID, regular, smooth and even because the power that drives the rolls also propels the machine at the same ratio of speed. It has surfaced and polished millions of square feet of the best floors in America and Europe.

GET A MACHINE that does first-class work and in paying quantities, that is fully guaranteed and sold on its merits. Don't be fooled with an imitation.

We sell direct to the users. Write for our free book "Surfacing Floors as a Business"
 Use Our Champion Double Disc Machine for Cement, Terrazzo and Marble Floors.

Manufactured by **The American Floor Surfacing Machine Co., Toledo, O.**



\$25.85



THE ADJUSTABLE TOOL

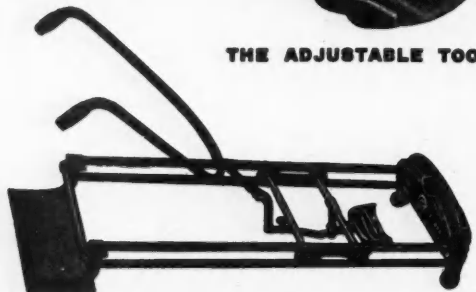

The Haven Planing Floor Scraper

THE
Haven Planing Floor Scraper
 Becomes the **STANDARD TOOL ON THE JOB**

wherever it is used. Builders have awakened to the fact that it solves the problem for good. Our machine differs entirely from all others. The secret of our splendid success rests on the following points:—

- (1) The scraping tool is a true plane, the world's standard leveler.
- (2) A light running carriage.
- (3) A smooth trackway for carriage.
- (4) A shearing cut on the instant.
- (5) Machine remains stationary while scraping enclosed area.
- (6) Angle of blade and thickness of shaving regulated with ease.
- (7) All woods are alike easy.
- (8) No man-killing truck to pull or push; you rest on the return stroke.
- (9) Planes and scrapes simultaneously.
- (10) No chattering, waving or gouging.
- (11) The planing head does better work than the usual hand work, and from four to six times as much.

If you have tried other machines and been disappointed, then TRY OURS AND BE CONVINCED THAT WE HAVE THE GOODS. A TRIAL COSTS YOU NOTHING. DON'T BUY AN INFERIOR MACHINE WHEN YOU CAN GET THE BEST ON EARTH FOR \$25.85. Send for booklet and complete information concerning our guaranteed machine and free trial offer.

THE HAVEN MFG. CO. RACINE, WIS.

Does \$40 Mean Anything To You?



Buy a **Stearns** and save **\$40**

Buy the Floor Scraper that's within your means. If you can't afford to pay a big price, a big, expensive floor scraper will be a "white elephant" on your hands. You'll hate yourself for tying up to a deal that eats up a year's earnings.

The Stearn's Floor Scraper is made for the man who wants to do good work but has no money to throw away. The Stearns is a simple scraper that works clean and smooth as a whistle. Scrapes close up to the wall and in all those corners and cramped spaces. Blade is 6 inches wide and the machine runs evenly and quietly on 5-inch rubber-tired wheels. The Price? Well, let's be frank. If we didn't sell so many of these scrapers, we couldn't make the price so low. The Stearns is a corker at the price we ask.

If you can't buy a Stearns in your town, write us. We'll fix you up. Anyway we have some STEARNS FACTS that you might look over. Just write and ask us to tell you more about the "Stearns."

E. C. STEARNS & CO.
 400 Oneida Street Syracuse, N. Y., U. S. A.

Scrape Your Floors With **this LITTLE GIANT—**
 You Can Try It At Our Expense



A floor scraper is now a necessity with every builder. In this Little Giant you get a floor scraper you can always depend upon to do its work properly. It is easy to operate. Scrapes floors rapidly, perfectly and economically. We'll let you try this Little Giant before you buy it—a fair proposition—and you can prove to yourself just what it can do. Write us NOW for our special offer for YOU.

The THOR Electric Home Laundry Machine

should be in every home. This machine does away with all laundry troubles. Home owners and builders appreciate their convenience and usefulness and it is good policy on your part to install them for your clients. There are now more than 62,000 in use. Sizes, designs and prices to meet every requirement. Sold on liberal FREE TRIAL EASY PAYMENT Plan.

Electric Washers from \$30 up

You ought to have our circular matter describing our Little Giant Scrapers and THOR Washing Machines. Write for this NOW.

Hurley Machine Company
 New York 1008 Flat Iron Building
 37 S. Clinton Street, Chicago



You will get SPECIAL ATTENTION if you tell Advertisers you read American Carpenter and Builder.

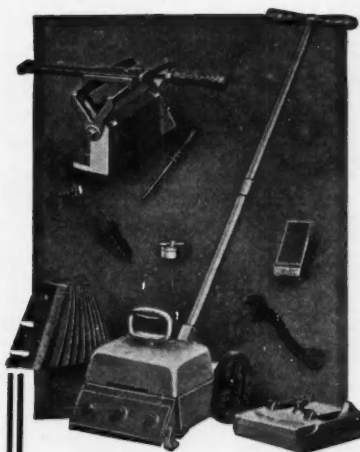

**Contractor
Tries
Acme
Floor
Scraper—
Buys It**

Salamanca, N. Y., Jan. 12, 1914

Jos. Miotke, Milwaukee, Wis.

Dear Sir:—

Inclosed you will please find check for payment in full for floor scraper sent me on trial. I am pleased to say that the scraper works fine and I am more than pleased with it. While the market here is not very large I believe the merits of the scraper will sell a few more here, as the work opens this season

Very respectfully, G. W. Rice.

The Acme Floor Scraper always makes good. After once using this time, money and labor saving outfit you will not part with it. Convince yourself by letting me send the ACME FLOOR SCRAPING OUTFIT to you on a WEEK'S FREE TRIAL at my expense. Write for catalog and particulars of my FREE TRIAL OFFER.

JOSEPH MIOTKE, 247 Lake St., Milwaukee, Wis.

\$20.00 IN GOLD and the machine Free if the Boss leaves a square cut on the Floor where you start; that's our Offer and we prove it. The Boss cuts more level than any other Scraper. The Gage on Front of the Knife is more like a Plane on Wheels. The thickness of shavings is regulated with two Thumb Screws over the Gage. The Knife can be set to any shearing cut.

Write for Prices.

G. J. Kepplinger

Main Office:
DWIGHT, ILL.

Factories: Dwight, Ill., and London, Canada.

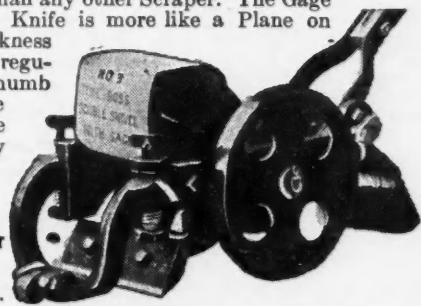

WOOD



**FREE TRIAL
5,000 in use**

**RAPID, FLEXIBLE, SELF-
PROPELLING WHEN
RAISING HANDLE**

Send for our new
list and free trial
proposition.

M. L. Schlueter
107 N. Canal St.
Chicago, Ill.

Made in three sizes:
8 x 16, 8 x 18 and 8 x 12 in. Flexible Roller.
Edge Roller easily adjusted to either side.



Delighted!!

**Eighteen Cents a Day Buys an
Adjustable Floor Scraper**

This amazing offer—the greatest of all Floor Finishing Machines at 18c a day—is open to YOU—NOW.

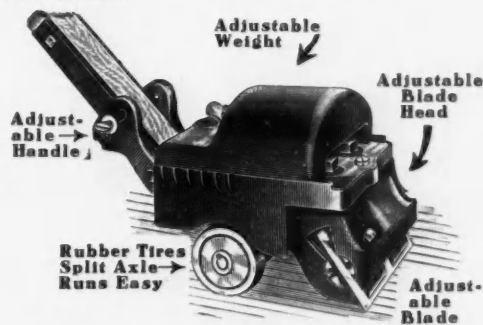

It's a

Universal Floor Finisher

The wide range of adjustments make it adaptable to every working condition of wood floors—hard or soft—old or new. It is simple, strong, durable. Nothing complicated about it. Anyone can use it. A true, smooth cut, and a uniform, perfectly finished surface without wave or chatter is always secured.

Your "cigar money" will soon buy an

Adjustable Floor Scraper

and it will earn dollars for you every day.

My 18c a day selling plan makes it cheaper for you to buy than to rent.

A small payment brings the machine to you. Then save a few pennies each day out of the dollars it saves for you and pay monthly.

MY GUARANTEE

makes you absolutely safe. If it don't do your work in a manner satisfactory to you at any time or for any cause due to the fault of the machine, you can have your money back if you want it.

Mail me this coupon NOW, before you forget it, and learn all about the Adjustable and my proposition. It will save you money.

H. P. DIDRIKSEN, Anderson, Indiana

Without obligating me in any way, please tell me about the Adjustable and how I can get it at 18c a day.

Name.....

Town..... State.....

You will get SPECIAL ATTENTION if you tell Advertisers you read American Carpenter and Builder.

A Good Elevator Is a Good Investment Saves Time and Labor

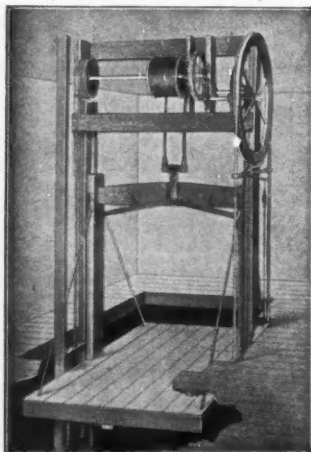

Our product includes *Dumb-Waiters, Carriage, Auto and Store Elevators*—Hand and Power.

These machines are serviceable and will pay for themselves in a very short time. Being practically self-contained, they can be erected by any carpenter or "handyman" in a few hours. Plans for erecting furnished with each elevator.

The Reasonable Cost Will Interest You

Write to us today stating your requirements, giving style of machine wanted, size of platform and number of feet travel and we will name you a money-saving price on equipment made to serve you well.

SIDNEY ELEVATOR MFG. CO. - SIDNEY, OHIO



CARPENTERS WANTED AS AGENTS
During Fall and Winter Months. Big Money; Ready Seller.

SANITARY AUTOMATIC DUMBWAITER

saves carrying food to and from the cellar. Perfectly ventilated; screened openings; finished inside with durable white enamel. Keeps food perfectly. Top lies flush with kitchen floor. You can walk over it. Operates with push button or lever. Also furnished as a Refrigerated Dumb Waiter. Write for Particulars and Price.

YORK AUTOMATIC DUMBWAITER WORKS
639 W. Market St. YORK, PA.



THE COLUMBIA

DUMB WAITERS ELEVATORS
CELLAR HOISTS
JUMPER DISAPPEARING DUMB WAITERS
CHAIN HOISTS, CRANES and TROLLEYS
SEND FOR CATALOGUE.

J. G. SPIEDEL, Reading, Pa.

The Best is None Too Good WE BUILD THE BEST!

A STRONG REASON why you should specify "SEDGWICK" where a hand-power elevator or dumb waiter is needed.

THE STRONGEST REASON why you should specify "SEDGWICK" is that it will positively add to your reputation, and thus result in actual profit.

There is a "SEDGWICK" for Every Place and Purpose!

Send for our 1914 Catalogue L, full of the latest developments in elevator and dumb waiter construction, and the easiest and best methods of installation.

Sedgwick Machine Works

132 LIBERTY STREET :: NEW YORK CITY

You will get SPECIAL ATTENTION if you tell Advertisers you read American Carpenter and Builder.

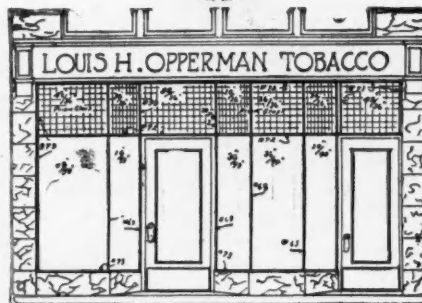

FRONT ELEVATION.

LEARN THE DIFFERENCE

between Petz Bars, and the many inferior and cheaper bars that may be offered you.

We want the chance, before you finally decide on the bar for that new store front, to show you why so many leading architects and builders are specifying Petz Bars—and no other kind—in their most particular work.

You can get this information, in compact and handy form, by writing today for our book "Modern Store Front Construction." It illustrates and describes the different styles of Petz Bars. We will gladly advise you as to the style of bar you need, if you will let us know what your requirements are.

DETROIT SHOW CASE CO.

491 West Fort Street Detroit, Michigan

NO FALLING WINDOWS
SMASHING GLASS
POCKET FRAMES
SASH WEIGHTS
RATTLING
BINDING
CORDS with

AUTOMATIC SASH HOLDERS

SPECIFY USE DEMAND

Automatic Sash Holders
and save labor, lumber and money.

Send for trial set (\$1 prepaid) stating approximate weight of sash, or our circular
Automatic Sash Holder Mfg. Co.
Church St., New York.

CHELSEA

EXEMPLAR OF QUALITY

Send for our Elevator and Dumbwaiter catalog

CHELSEA ELEVATOR CO. 330 W. 26th St., N. Y.

MONEY FOR YOU

By Our Plan

UNIVERSAL CLOTHES DRIER

The kitchen wonder.—Indispensable to every housewife. Can be attached to wall or casing. Easily removed. Contains 30 feet of drying surface. Adjustable to suit convenience of operator. Does away with lines and the cumbersome clotheshorse. No kitchen or laundry complete without a UNIVERSAL-DRIER. Neat, durable, irreplaceable. Every demonstration a sale.

Retails for \$1.50. Big commissions to reliable men.

WE WANT AGENTS

Write today for our liberal offer that will make money for you during the dull season. Can be raised to ceiling as shown by dotted lines

The Universal Clothes Drier Co.

Factory: Rutherford, N. J. Sales Dept. Ordway Bldg., Newark, N. J.

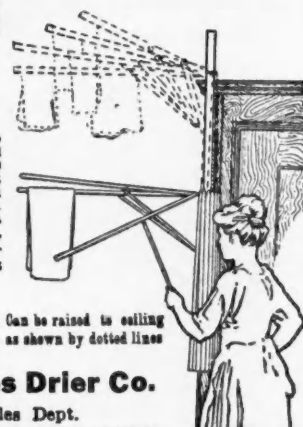



AUTOMATIC
Ball Bearing Electric
FLOOR SURFACING MACHINE

Quickly dresses new floors to stand inspection against the light, or rapidly refinishes old floors. Self propelling; has automatic brake for easy, continuous and uniform work. Surfaces to base board with Edge Roller quickly adjusted to either side doing away altogether with hand scraping.

Our Price Will Interest You

If you are interested in the best floor finishing, we want to show you what others are doing with our machine. Send for the names of well-known users. You should have our booklet too. Above all, get particulars about our **Free Trial Offer**. Made in 3 sizes for small rooms and large areas.

WAYVELL CHAPPELL & CO. Dept. 4847 E. Ravenswood Ave. CHICAGO, ILLINOIS

PHOENIX
INSIDE SLIDING **BLINDS**

WILKES BARRE, PA.

The Phoenix Sliding Blind Co.
Enclosed find my check for blinds. I am pleased with them and sorry I did not have them put throughout the whole house.
C. W. BURT.

Comfort!
Economy!
Convenience!

The lately improved springs and corrugated steel rods put the "PHOENIX" far in lead of less improved styles. Write for Catalogue "C" and free samples, showing construction.

PHOENIX SLIDING BLIND CO.
BRIDGE & CANAL STS. PHOENIX, N. Y.



Pay Me As It Pays You!

YOU don't have to put up any money to get my Scraper. Just make a small deposit five days after arrival of machine. Then, on the first of the following month, pay me 10% of the profits the Scraper has paid you, with small payments thereafter for six months.

The WEBER DOUBLE ACTING Floor Scraper

will earn enough extra profits to easily pay for itself in six months on my liberal Special Payment Plan. Write for my Free Trial Offer today, if you want to get the **right** Scraper on the **right** terms.

Opening for One Live Agent in Each Town.

JOHN F. WEBER, President
WEBER MFG. CO.
670 71st Ave., West Allis, Wisconsin



The Floors in Your Town

will furnish enough work to keep you busy during the dull season. When you consider that you can positively make \$20 a day re-finishing old floors, and the convenience of having a machine to surface the floors in your new buildings, then you're wise to buy

The Triple "A" Spring Driven Floor Smoother

Our own floor surfacing crew has averaged from \$18 to \$20 a day per man. Any inexperienced man can make the same money with the Triple "A." Re-finishing old, new, varnished, painted or grimy floors nets you from 1 to 3 cents per square foot. You can finish 1,000 sq. ft. a day. We'll guarantee that the Triple "A" Spring Driven Floor Smoother will finish any floor without wave or chatter, leaving the floor absolutely smooth and even.

The "Spring Motor" Lightens Work

The Triple "A" is provided with a spring motor which trebles the operator's capacity. The spring drive is a feature possessed by no other machine. When the Triple "A" is pushed forward, the spring winds and stops the machine automatically at the proper distance. The spring then releases and the machine starts back on the cutting stroke, engaging the blade in the floor. This spring drive is so strong that practically all the operator has to do is to guide the machine

You Can Afford the Triple "A." Here's Why

The triple "A" does not cost nearly as much as a power machine. It has all the advantages at a lower cost. We'll sell you a Triple "A" for cash or we'll allow you to pay for the machine out of its own earnings. A small amount each month makes the Triple "A" your machine. Satisfaction or money back.

Send the Coupon Today and Get Full Particulars Free.

Triple "A" Machine Company
Room 313
300 West Grand Ave. Chicago, Illinois

COUPON. TRIPLE "A" MACHINE CO., Chicago, Ill.
Room 313, 300 W. Grand Ave., Chicago, Ill.

Tell me how I can earn \$20 a day with the Triple "A." Also send me complete description of this machine. I don't obligate myself in any way.

Name.....
Street.....
Town.....
State.....

You will get SPECIAL ATTENTION if you tell Advertisers you read American Carpenter and Builder.



90 Cubic Yards Per Day

Saves 60 to 90 cents on every yard. Pays for itself several times each season. Gives you the edge on your competitors. So light that two men can carry it. Big savings in freight and handling. Can always be set to discharge direct into forms. Saves all wheeling from machine. This alone saves one-third the labor necessary to operate other mixers.

Not a Man-Killer
Has an enormous capacity

SIMPLE—COMPACT—HANDY—SUBSTANTIAL

New Principle—Quick Charging—Quick Action—Quick Discharge

Its mixing blades have a criss-cross, kneading, plowing, hoeing motion which press and fold the entire batch over upon itself many times every second. Insures a quick and thorough mix. You will be proud to say you have a Northfield Hand Batch Mixer, once you see its work.

The SLUSH mixer mixes 4 cu. ft. of finished concrete per batch. A batch per minute or 90 cu. yds. per day is easily possible under favorable conditions. 30 to 60 cu. yds. per day is a fair average on ordinary abutment, floor, wall or bridge work. Over 10 cu. yds. per hour have been averaged. When operated by power—one man alone can mix mortar fast enough for a crew of 20 brick layers.

The DRY or WET mixer is good for any kind of mixing—either Dry, Wet or Sulsh. Is extra fine for brick or block plants, core sand, plaster, brick mortar, chemicals, etc. Capacity—2 to 3 cu. ft. per batch—or 15 to 45 cu. yds. per day. Is just like the SLUSH mixer except a slight change in the drum heads and agitator. Is the best for an all-purpose mixer. The SLUSH mixer is best for big jobs and rapid contract work where slush mixtures are used.

Two men turn either machine easily and do not work as hard as the shovellers. A pump engine will run them. It is not necessary to have a big expensive power mixer to economically mix concrete. No job is too big or too small for the Northfield. No better mixer can be had, even at ten times its price.

Write direct to factory for catalogue, prices and terms.

NORTHFIELD IRON COMPANY
402 Water Street - Northfield, Minn., U. S. A.

GET THESE BOOKS

FREE!!!

A post-card, or this ad cut out, with your name and address, designating what books you want is all that is necessary. These books will interest you, and also place you in touch with equipment that you can buy for LESS MONEY than any other. Our

DIRECT FROM FACTORY PRICES ON World-Renowned "CRESCENT" Machines

will make you ask yourself why you never got in touch with us before.

Find out how the other fellows make money. You're never too old to learn!

Mark the Books You Want

- Book 10, "Crescent" Continuous Concrete Mixers
- Book 11, "Crescent" Sewer Pipe and Tile Molds
- Book 12, "Bull-dog" Hand Batch Mixers
- Book 14, "Crescent" Vertical Tamping Brick Machines (Foot-power)
- Book 16, "Bull-dog" Power Batch Mixers
- Book 17, "Crescent" Power Brick Machines
- Book 18, "Little Wonder" Hand Brick Molds

GET OUR QUOTATION ON ANYTHING YOU NEED

RABER & LANG MFG CO.
Kendallville, Ind. 810 Mill Street

Buy The SIMPLEX 1914 Model MIXER

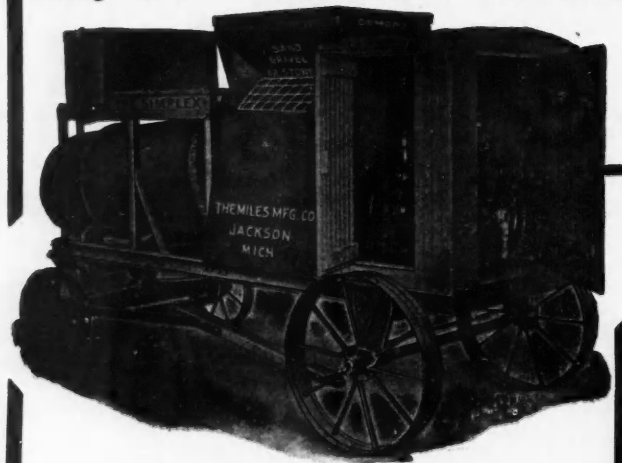

Combining the good features of both batch and continuous mixers in the one machine.

The best feature of the Batch Mixers is the rolling of the materials. The greatest advantage of the Continuous Mixer is the automatic measuring and feeding of the materials.

Only one machine combines these two features—the SIMPLEX. It's the happy medium between the two types of mixers, giving the points of advantage claimed by each, and eliminating the faults of both.

Write for New Complete Catalog.

The Miles Mfg. Co.
309 E. Franklin St. JACKSON, MICH.

A Combination Mixer and Hoisting Engine

The Biggest Money Maker for Carpenters

LITTLE BOSS MIXER

5 ft. 50 cu. yd. cap. 3 h.p. engine

\$198.00 Ask for Our Easy Payment Plan
CASH



\$20 a Day Saved

Buy a Mixer built to last, not a "freak" because it is cheap—BOSS at cost 35 cents day for fuel, will mix concrete, put in your foundations, or elevate your lumber and materials one or five stories.

Little BOSS Mixer has more power than some \$400 mixers and compares with any machine on market for thorough and fast mixing. Built of steel and iron. Chain transmission. Can be furnished with side loader.

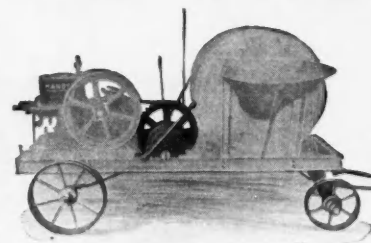

BOSS HOISTING DRUM
Guaranteed load 500 lbs. Speed 80 ft. minute. Holds 300 ft. cable.
Has safety brake.

SEND FOR OUR CATALOG

We sell concrete machinery at usual wholesale prices—let us save you half.

Don't Fail to Write Us Today for Catalog and Our Liberal Proposition
The AMERICAN CEMENT MACHINE CO., Inc.
1006 Johnson Street KEOKUK, IOWA

You will get SPECIAL ATTENTION if you tell Advertisers you read American Carpenter and Builder.



LITTLE
WONDER
"FIVE"
Discharging
Position

PAT. JAN. 24, 1905
PAT. JAN. 29, 1907
OTHER PATS. PENDING

THE WONDERS OF THE CONCRETE WORLD

TAKE advantage of the tremendous endorsement of small contractors for the WONDER "FIVE," or the unanimous approval of heavy contractors and engineers for the WONDER "TEN," to eliminate risk in your choice of a mixer.

From all practical standpoints—quality of construction, durability, speed and economy of operation, perfection of mix, portability, great range of utility—absolute earning capacity, WONDER mixers have overwhelmingly proved their superiority—they are truly WONDERS.

Each machine, in its field, challenges comparison with any and all mixers. Make this comparison—see how, point by point, WONDER mixers out-class all others and score in features that count for the most profit and greatest satisfaction in the long run.

Don't allow anybody or anything to interfere with your personal investigation of these machines before deciding what mixer to purchase.

**SEE THEM AT THE
CEMENT SHOWS**

Omaha, Jan. 30-Feb. 4
Chicago, Feb. 12-21

**WATERLOO CEMENT
MACHINERY CORP'N**

103 Vinton Street, Waterloo, Iowa

You will get SPECIAL ATTENTION if you tell Advertisers you read American Carpenter and Builder.

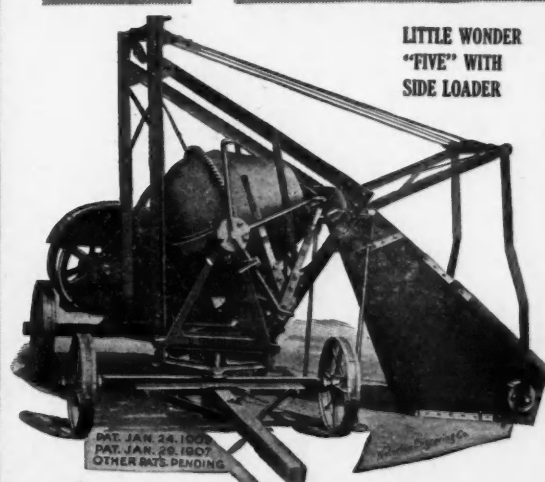

LITTLE WONDER
"FIVE" WITH
SIDE LOADER

PAT. JAN. 24, 1905
PAT. JAN. 29, 1907
OTHER PATS. PENDING

THE
LITTLE
WONDER
"FIVE"
and the
WONDER
"TEN"

They are
**"THE MIXERS
THAT MAKE
THE MONEY"**

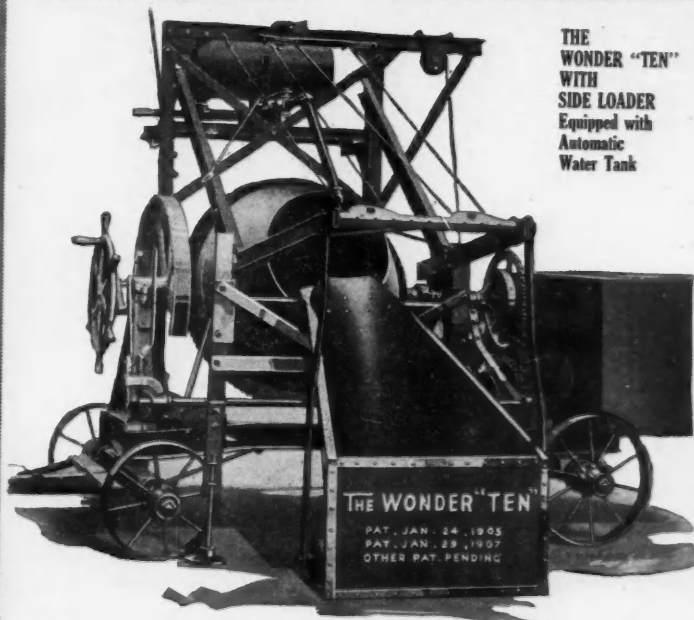

THE
WONDER "TEN"
WITH
SIDE LOADER
Equipped with
Automatic
Water Tank

THE WONDER "TEN"

PAT. JAN. 24, 1905
PAT. JAN. 29, 1907
OTHER PAT. PENDING

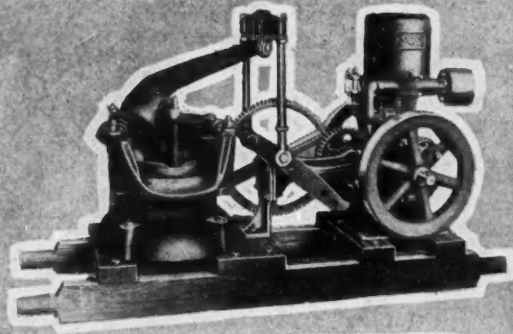

You who want
"EFFICIENT
on your work

Several thousand contractors last year mixed and handled their concrete with at least $\frac{1}{3}$ saving over their previous method, and it wasn't a miracle either.

They saw the "Efficient Economy" of
LOW CHARGING

they saw $\frac{1}{3}$ saving on first cost—on power and labor cost—on wasted time and repair cost—that "Direct from the Barrow Charging" was the key to the chest of Greater Profits and Bigger Contracts.

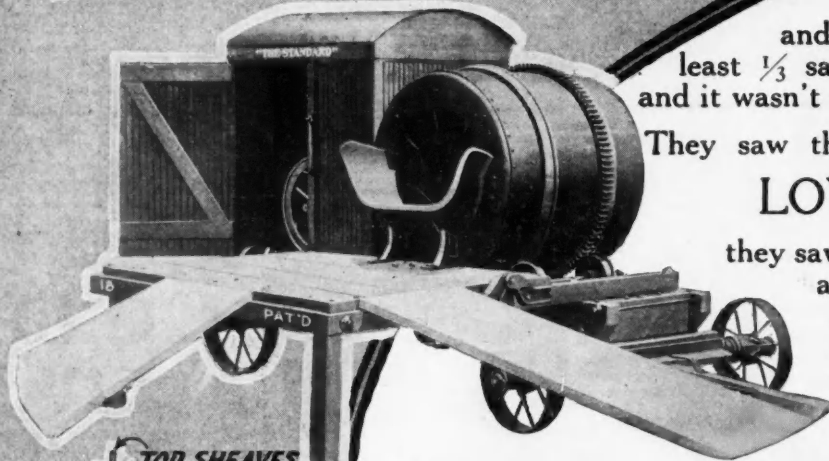

"The STANDARD"

You who use mixers know that they are the most important factor on the job. Give us a chance to show mixer importance.

"The STANDARD" Low Charging Concrete Mixer — a locomotive for your equipment, has a "knack" of paying for itself and rushing your work—it can't help it, it's built to withstand the hardest of contractors usage and has always proved it's name in the long run. It's queer thing but—

Many of "THE STANDARD" owners, own more than one mixer—some up to 33—they see saving in "Standardized Equipment." How about you? "It pays."

See us at Chicago Cement Show,



TOP SHEAVES

RECEIVING HOPPER

CHUTE

The Standard

Chicago
 1345-47 Wabash Ave.

Pittsburgh
 243-45 Water St.

You will get SPECIAL ATTENTION if you tell Advertisers you read American Carpenter and Builder.

Want more "ECONOMY" in your mixing equipment

Low Charging the money saver for all contractors—To the big contractor it means the less money spent on equipment same output with less labor—in less time and less cost per cubic-yard. To the small contractor it means 3 times more output with 1/2 less labor—1/3 saving on cement over hand mixing.

Get wise to LOW CHARGING

Can you want any more "Efficient Economy" than is shown here? Can you expect any thing more than a reduction of your labor cost per cubic-yard? We offer you a mixer that will more than meet expectations. Let us know your expectations and we will show you something of how these are met by the mixer of

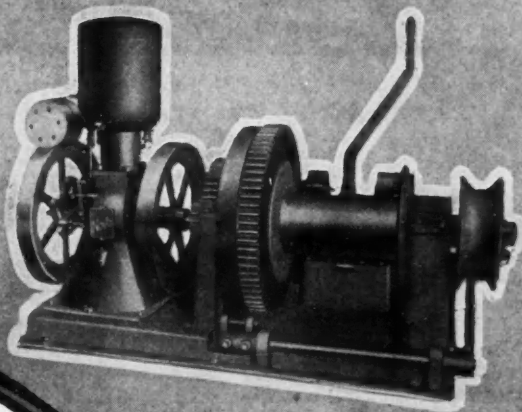

"STANDARD" Lines

1914 is going to be one of the biggest years for concrete industry. The low bidder gets the "cream" of the bunch—but don't cheapen the quality of your work to be low bidder.

Save your work but cut your labor cost by using the labor saving, time saving features of

"The STANDARD"

Low Charging Concrete Mixer.
Let us help you figure your bids

"IT PAYS"

Write for catalog No. 44 E.

Booth 172-173

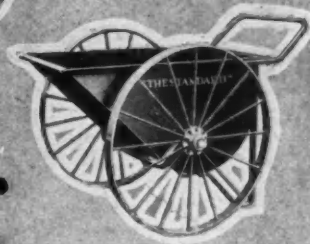
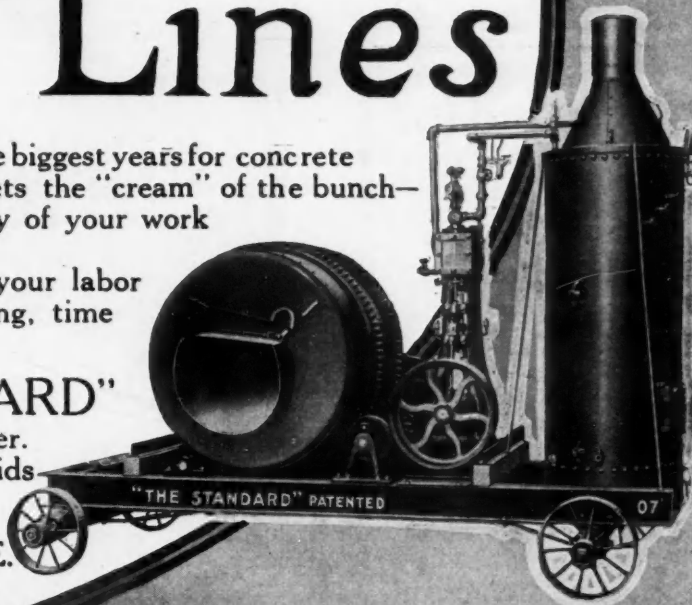

Wholesale & Supply Co.

Philadelphia
35 - South Fourth St.

New York
136 W. Broadway

You will get SPECIAL ATTENTION if you tell Advertisers you read American Carpenter and Builder.

POWER BATCH Concrete Mixer



The Whitworth is a bargain at the price. It will take care of the cement and concrete jobs in connection with your work. Great for sidewalks, floors, etc.

Built strong and heavy. Weight 335 lbs. Mixes 6 to 7 cu. ft. per batch. Drum 36 in. long by 20 in. wide. Requires little power. A 1 1/2 h. p. engine runs it easily. These mixers are selling fast. Send in your order at once to avoid delays. Price \$33.75. Money right back if you're not satisfied.

MONARCH SELF FEEDER CO. Cedar Falls, Iowa

The advantages of a Light, Portable Power Mixer such as the Bolte, weighing less than 1000 lbs., with a capacity of 120 cubic yards per day are features that produce the profits for the contractor.

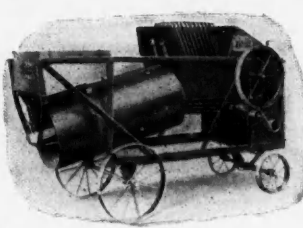

ASK FOR CATALOG AND PRICES.

Address— **The Bolte Mfg. Co.** Avenue, A. KEARNEY, NEBRASKA

Address— **The Bolte Mfg. Co.** 420 East 2nd St. CINCINNATI, OHIO

MADE TO ORDER Fly Screens and Screen Doors



We use the best grades of wire cloth, black enamel, galvanized, pearl and copper bronze, fastened by the improved Standard Shoulder Strip Method, which makes the wire drum tight and firm, can not sag or pull away.

See That Corner? Notice how stiles are fitted into rails.

Dealers, Carpenters, Contractors and Builders, write for a free copy of our 1913 illustrated catalog

STANDARD SCREEN CO., 1848-50 W. 14th St., Chicago, Ill.

Our screens are all mortised, tenoned, joined with waterproof glue and pinned with steel pins, will last a lifetime.

Introducing the New Sasgen Peerless Steel Derrick



with a full circle swing. Capacity 2,000 lbs. Drum runs in SELF-LUBRICATING BEARINGS. Bottom sills and mast can be folded together.

PRICE ONLY \$45.00

equipped complete for hand and power with 125 ft. crucible steel cable, swivel block and fasteners. \$2.00 less for hand power only.

Write for Illustrated Circular No. 2

T. P. Setter Pole Regular Setter
Our motto — "Satisfaction or No Sale."

SASGEN DERRICK CO.
2053-57 N. Racine Ave.
CHICAGO, ILL.

CANADIAN OFFICE, 13 JARVIS STREET, TORONTO, ONT.

Supplies the Demand for a Small Perfect Mixer



Capacity 3 Cubic Feet Per Batch

Weight 800 Lbs.

On Trucks 1000 Lbs.

On Trucks with Engine 1400 Lbs.

McCracken Batch Mixer

The McCracken Portable Batch Mixer

is designed and built to meet the demand for a strong, simple, durable and practical mixer, that is large enough for all ordinary contract work, yet light enough to be profitable on the small job as well as on the large. Mounted on good steel trucks, EXTRA LARGE DRUM OF THE PROPER SHAPE, equipped with our own high-grade 2-HP. SIOUX engine, enclosed in a good steel housing (not a cheap box), also has friction clutch, so that drum can be started and stopped without stopping the engine. Capacity, twenty-five to thirty-five yards per day. Cost for power, twenty-five cents per day. The largest, best and most complete mixer on the market for the money. Write today for prices.

Write for Further Particulars

Sioux City Engine & Machinery Company
9th and Division Sts. SIOUX CITY, IOWA

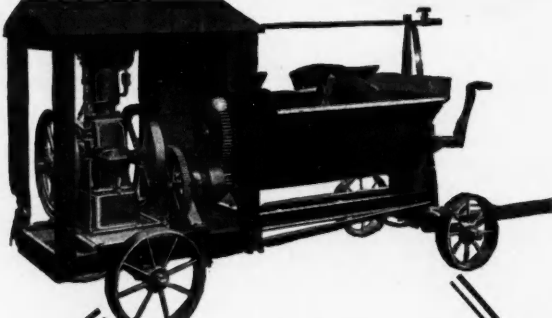

Built for Work

The Blystone Concrete and Mortar Mixer was designed by a practical concrete man to meet his own needs. He solved your problems when he solved his own.

It was not originally made to sell, but was wanted to do this man's work. It did his work so well it forced itself onto the market.

The Blystone will mix fibre through hardwall plaster perfectly. Whether the material is wet or dry does not matter.

The material is always in view while being mixed. The open drum is easy to clean.

Mounted on skids with pulleys for belting to power, the Blystone makes a mixer that positively cannot be equalled for the block or tile plant.

You will be interested in a complete description of this unusual mixer. Write while you have it in mind.

THE BLYSTONE MACHINERY CO.
19 Carpenter St. : CAMBRIDGE SPRINGS, PA.

You will get SPECIAL ATTENTION if you tell Advertisers you read American Carpenter and Builder.

THE LANSING BRONCHO MIXER

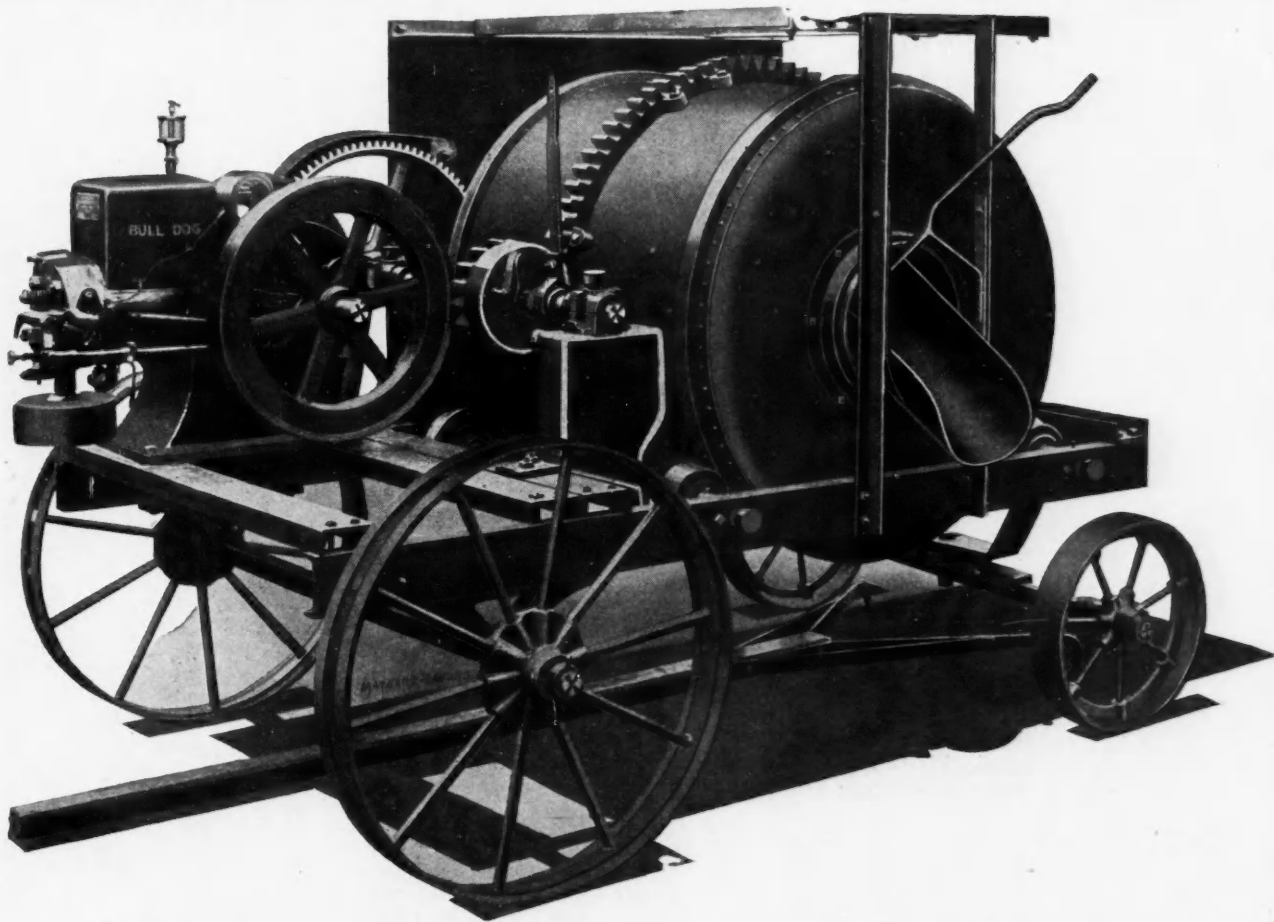

The BRONCHO is the real Pioneer in the small mixer field, therefore has back of it more actual experience and opportunity for improvement than any other machine in its class. Don't waste time and money with experiments.

Hundreds of contractors adopted it last year. Many of them are in small towns and the country and are hauling their machines from one end of the country to the other. This is the service the BRONCHO is built for. Rough streets and country roads have no terror for it.

SPECIFICATIONS

Height, 5½ ft.
 Length, 8 ft.
 Width, 4½ ft.
 Diameter of drum, 3 ft.
 Length of drum, 3 ft.
 Inlet opening, 20 in.
 Discharge opening, 12 in.
 Loading hopper only 34 in. from ground.
 Discharge, 26 in., high enough for wheelbarrow.
 Weight, 2500 lbs.
 Engine, 4 H. P.
 Capacity—Very wet mix, 5 cu. ft.
 Capacity—Dry mix, 7 cu. ft.
 Capacities guaranteed absolutely.

The 1914 model BRONCHO (now ready) is truly a marvel in construction, capacity and price. No picture can do it justice. The present engine develops 50% more power than the one used last year; the frame is strengthened; the pole is heavier; a stronger front bolster, giving the axle 100% more carrying strength, making it even better adapted to country work. Cast iron drum heads have replaced steel; the tracks and the trunion wheels are machined till the drum runs as smoothly and true as a watch. The new slop rings and discharge chute allow overloading without spilling, and the dumping is rapid and clean.

All these and many more improvements have been made in the Broncho without advancing the selling price a cent.

Many of this year's features do not appear in the view above, but they are all included in every machine shipped out. Over twenty-five agents and branch houses have the new model machines in stock. Write today for the nearest address.

Owning a Broncho Mixer gives a man prestige and standing in his community. Not only is it a money-maker on his present work, but it puts him in line for the bigger and better jobs. Can you afford to be without a mixer?

LANSING COMPANY, ⁷²⁶ Cedar St., Lansing, Mich.

BRANCH HOUSES:

New York, 288 West St. Chicago, 169 W. Lake St.
 Boston, 78 Cambridge St. Kansas City, 923 Mulberry St.
 Philadelphia, Cor. American and Willow Sts.
 Minneapolis, 330 N. First St.

Detroit
 Indianapolis
 Columbus
 Cincinnati
 Cleveland

Lynchburg
 E. St. Louis
 Pittsburgh
 Frankfort
 Charlotte

Atlanta
 Memphis
 Portland
 Seattle
 Tacoma

Los Angeles
 Jacksonville
 Boise
 Winnipeg
 Lethbridge

You will get **SPECIAL ATTENTION** if you tell Advertisers you read **American Carpenter and Builder**.

**“I Have Built School Houses, Churches,
Dwellings, and Stores and in my
Six Years of Constant Use I Have Not Paid
Out Over \$10.00 for Repairs”**

—O. S. KELSO, Winnimac, Ind.

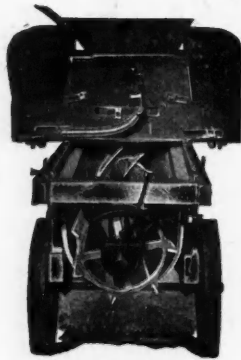

No. 12 Coltrin Mixer

The Knickerbocker Co.,
Jackson, Mich.
Gentlemen:—

Winnimac, Indiana, Jan. 13, 1914.

The Coltrin Mixer that I am using I bought from Hagenbush & Miller six years ago in March coming. They told me they had used it two years. They were using hand power. I put a 3 H. P. engine on it and have used it in all my work since, both in my factory and my foundation work. I have built school houses, churches, dwellings and stores, and in my six years of constant use I have not paid out over \$10.00 for repairs, and have made ten times that much renting out when I was not using it.

Respectfully yours,

O. S. KELSO.

Study the Mixing Method

Which has gained such a remarkable reputation of producing uniformly good concrete at a minimum cost for

The Coltrin Continuous-Batch Mixer

Shipped anywhere on trial

See them at the

Feb. 12-21—CHICAGO CEMENT SHOW—Space 46-47

The Knickerbocker Co., Jackson, Mich.

Our 1914 Catalog is now ready for you

You will get SPECIAL ATTENTION if you tell Advertisers you read American Carpenter and Builder.

WHEREVER YOU SEE **Clover Leaf** IT ASSURES QUALITY

Two machines that will appeal to the "good" buyer's judgment are the **Clover Leaf Mixer** and the **Clover Leaf Builders' Hoist**.

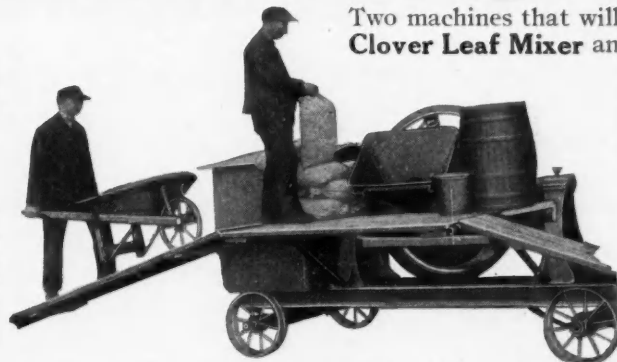

The **Clover Leaf Mixer** is already a favorite with builders because it **mixes concrete and mortar equally well**. You couldn't get a better mortar mixer than the Clover Leaf. Saves the cost of two machines. A fine machine strongly built, and simple enough in construction to require no repairs for years.

The **Clover Leaf Builders' Hoist** shown here is the one you need on every job. Saves its cost in removing excavated material or raising supplies to any part of a building. A convenience modern building

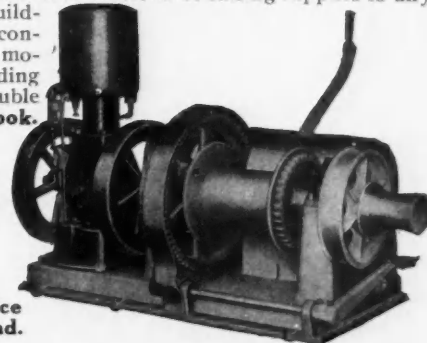

demands. Reversible drum or single line lifting; sheave for single or double platform elevating; winch head for general purposes. **Get our Hoist Book.**

You can't buy better equipment than the **Clover Leaf Machines**. Price reasonable. Quality away above the average. Ask for **Mixer Catalog** or **Hoist Book** or both.

THE CLOVER LEAF MACHINE CO. Sample St. Office South Bend, Ind.

The Helper Mixer

Just the machine you want. Will mix concrete and mortar rapidly and thoroughly. Requires $1\frac{1}{2}$ H. P. engine to run it. Average daily capacity 15 to 20 cubic yards.

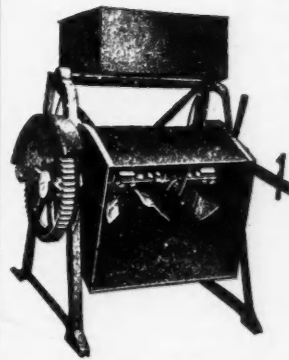

The Winner Mixer

Is still in the lead *winning* in the race of Reduced Concrete Construction. Built in 4 and 5 cu. ft.



sizes. Daily capacity 30 to 40 cu. yds. Only requires one gallon gasoline per day to run engine.

See these mixers at our booth, No. 168, Chicago Cement Show.

Write for Free Catalog.

THE CEMENT TILE MACHINERY CO.
131 Rath Street Waterloo, Iowa

THE BABY GRAND

A Small Continuous Mixer of Special Value to the Contractor for all Inside and Outside Work on EVERY JOB

The Baby Grand saves time and money on all jobs where a big mixer would prove too expensive. It shows true economy in foundation and sidewalk work, in brick and block plants and wherever else a substantial saving is required. It is the very machine for such concrete work as the average contractor, carpenter and builder has to do.

Mounted on 3" channel iron frame. Steel axles $1\frac{1}{2}$ " diameter. Steel wheels. Engine mounted on large casting. Power transmission by gears. Engine and gears carefully housed. Two feeders—one for cement and the other for sand and gravel. Mixing trough No. 10 guage steel—6 feet long. Mechanical proportioning and feeding device insures economical and uniform concrete.

We also manufacture the Hartwick Two Trough Mixer. A larger mixer for all kinds of construction work. The best of its kind.

ASK FOR CATALOGS



Hall-Holmes Mfg. Co.
434 Oak St.
Jackson, Michigan

You will get **SPECIAL ATTENTION** if you tell Advertisers you read **American Carpenter and Builder**.



Make Big Profits in the DRAIN TILE Business.

Concrete Drain Tile offers the greatest money-making possibilities of the century. *Absolutely.* In no other legitimate business today is the demand so great, the profits so certain, or the initial investment so small. *You cannot help but make money.* The opportunities are open to the beginner with small capital and to those already established in the concrete business.

For farmers must have drain tile—and they prefer cement tile to clay. *You can undersell clay tile* because you pay no high freight rates or dealers' commission. Your business is transacted directly with the consumer. You have absolutely no competition. *Only be sure and get the right machines!* DUNN equipment has *proved* its ability to make the biggest profits.

The DUNN "AUTOMATIC" —The Tile Machine Wonder of the Age!

Every other cement drain tile machine on the market is obsolete when compared with the DUNN "Automatic." A strong statement, certainly, but *facts prove it.* From mixing the concrete to making the finished tile, the operation is entirely automatic. Here's the process:

The concrete is discharged from mixer into lower hopper. A slide arrangement permits a required amount of material to be fed into the boot, and from there, conveyed into top hopper by an endless chain bucket conveyor. From there it drops (without "arching") into the automatic feeder which fills the empty casing, which has been automatically placed into position to receive it. At this instant the packer head rises from below, packing the bottom of tile for several revolutions before rising to pack the sides. On its up stroke the packer head makes 40 revolutions, and 20 on its down stroke, so that each tile is of equal density from bottom to top.

Every stage of the operation is under direct lever control, and the machine is equipped with back gearing, permitting it to be operated at half speed without changing the speed of the pulley; this is sometime necessary in making big tile.

DUNN No. 1 Drain Tile Machine \$165

The DUNN "Automatic" makes six tile per minute. It saves the labor of *at least* one man which means it will pay for itself in a year from this *one feature* alone. Solidly constructed with heavy base and large bearings, and all working parts are enclosed away from dust. It is the only tile machine that can be *operated by one man.* Makes all sizes from 3" to 16" in diameter.

Investigate this great time and labor saver. Write today for large descriptive folder and prices.

For the man with small capital this machine is unequalled—in service and price. Compact, simple in construction and operation and of ample capacity, it is the only moderate priced machine that fills the bill. Turns out a better product, is more reliable and lasts longer than machines costing double. No overhead frames nor flimsy angle iron construction. The Dunn No. 1 is fed from above and packed from below—the packer head does service *up and down.* Each tile is packed solidly, top and bottom, and is of equal density all through. *Look at the design!* See how the machine stands—firm as a rock—on its heavy base—with all mechanism enclosed in a single heavy casting!

This machine makes all size tile, from 3" to 12" diameter, all 12" high, and two men can make 2,000 tile daily. Sold on 15 days' trial for \$165.

W. E. Dunn Mfg. Co., 4132 Fillmore St., Chicago

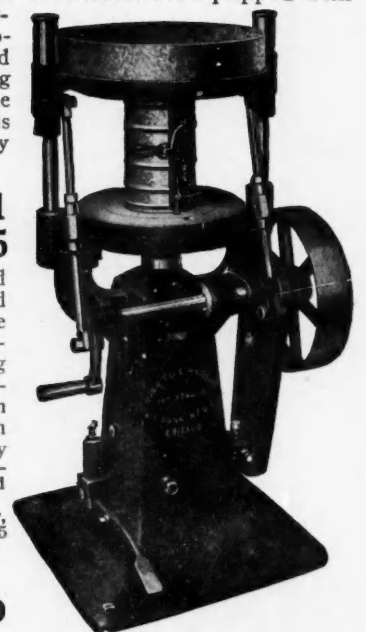

15 Days' Free Trial of DUNN Concrete Machinery

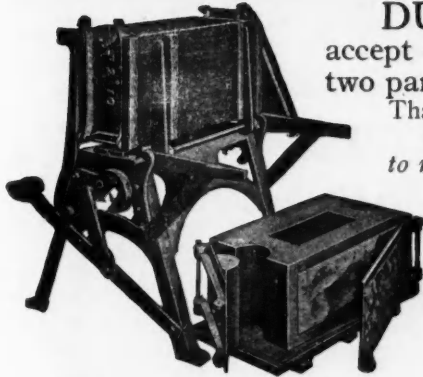

DUNN Machines are sold direct from factory to user—and we accept all responsibility. The usual jobbers' and dealers' profits are divided in two parts—one part we put into the *machine*, the other part into *your pocket*. That's why DUNN equipment is so high in quality and so low in price.

We will put any DUNN Machine in your plant for 15 days' trial—to prove its ability to meet your conditions—before we accept a red cent of your money. That's the way we do business. Then, if you don't wish to keep it, just ship it back. No obligation whatever and *no risk*. When you decide to buy, you *know* you are getting your money's worth; it shows our faith in our own machines. It insures *honest trading*.

\$40 For this DUNN Block Machine

Sometimes you want to make a Face-down block, other times a side-face block—or a two-piece wall block. On this DUNN Machine you can make all three types. It's really three machines in one. It permits the use of wet mixture (which makes the strongest block) and makes 150 perfect blocks per day without the aid of skilled labor. The 16" machine makes three sizes of block—8x16", 10x16" and 12x16". Sold on 15 days' trial, for \$40.00.

DUNN "Utility" Mixer, \$100

The batch mixer for plenty of hard service. Mixes in full view of operator; can be charged from either side; cannot clog or get out of order; has a capacity of 5 cu. ft. to the batch; will mix a batch every two minutes; has power or hand wheel discharge. It is the one reliable mixer for every concrete work and is far superior in construction and operation to any mixer selling for anything near its price. Sold on 15 days' free trial for \$100 (hand-wheel discharge).

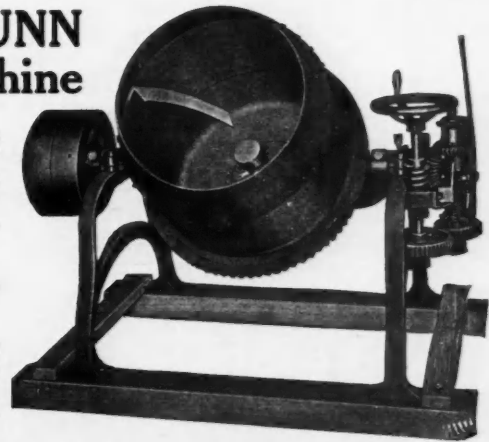

Everything for Concrete Porches

Concrete Porches are used on old and new houses—whether they're built of concrete blocks, brick or wood. House owners like them because they are ornamental and long lasting. There's always a big demand and the profits are big. We furnish molds for making them complete. Also molds for making Chimneys, Posts, Piers, Lattices, Cornices, Vases, etc., etc. All sold on 15 days' free trial.

Concrete Book—FREE
Tells about the possibilities in the concrete business; gives cost of manufacture, selling prices and profits, etc., and describes the DUNN line of concrete machinery. Write for a copy today, no charge whatever.

DUNN Pipe Molds

For making large sewer pipe and drain tile DUNN Pipe Molds are ideal, insuring a perfect product and permitting a good profit on the investment. There's always a big demand for this class of work; with DUNN Molds you can supply it satisfactorily and profitably. That wet mixture is poured into the molds; no tamping, and the product is unusually dense and durable. All sizes, from 6" to 36" in diameter by 24" long. All sold on 15 days' free trial. Price of 12" mold is \$7.50. Prices of other sizes in catalog.



Complete Working Exhibit at Chicago Cement Show

At the Chicago Cement Show, from February 12th to 21st, there'll be 600 sq. ft. of floor space filled with DUNN Machines in *actual operation*. Don't miss this. You'll see the DUNN Tile Machines turning out the most perfect cement drain tile possible; you'll see our Utility Batch Mixers on skids or trucks, mixing concrete quickly and correctly; you'll see. DUNN Molds for making sewer pipe, concrete porches, chimneys, etc. Remember the date—February 12th to 21st, and the place—the Coliseum. In the meantime write us for catalog and information on any equipment you are in the market for.

W. E. Dunn Mfg. Co., 4132 Fillmore St., Chicago

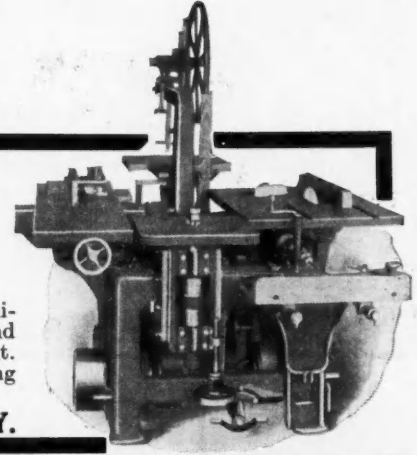
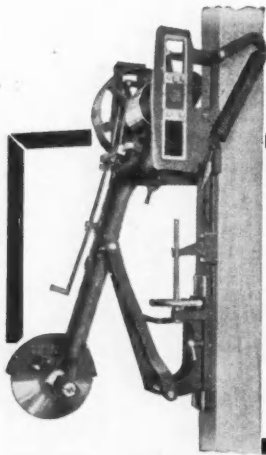

EXHIBITION

Complete line of Wood Working Machinery including Universal Combination Woodworkers for Contractors and Builders. Largest stock in New York. New and rebuilt. We are manufacturers of high-grade woodworking machinery. Sixty years in the business. Write us.
P. PRYBIL MACH. CO., 512-24 W. 41st St., New York, N. Y.



No. 8 "UNION" COMBI-NATION SAW

\$30⁰⁰₁₀₀ A well-built, light power machine, at a low cost, and has a wide range for work will rip stuff up to 3½ inches thick, also cutoff, mitre, and with attachments, bore, edge-mould, groove, dado, etc.

The No. 8 Union Saw may be easily connected to electric motor or gasoline engine and complete outfit mounted on skids to move from one job to another.

SEND FOR CATALOG A

describing our line of Foot and Light Power Wood-working Machinery.

THE SENECA FALLS MFG. CO., 218 Water St., Seneca Falls, N. Y., U. S. A.

275

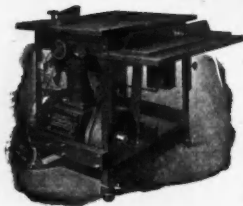
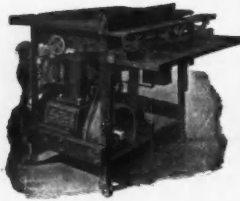

Standard Portable Combination Woodworker

9 Machines in 1
6 P. P. ENGINE

SEND FOR CATALOG G
ATLANTIC ENGINE CO.
Meadville - Penna.

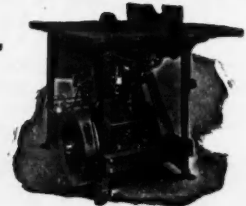
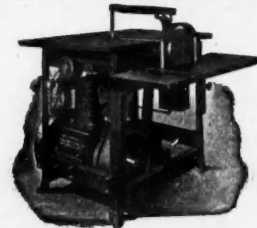

SAMSON SPOT SASH CORD

Made of extra quality stock, carefully inspected, and guaranteed free from the imperfections of braid and finish which destroy common cords so quickly. The spots on the Cord, in any color, are our trade mark. Don't be misled by imitations. Samples and full information gladly sent.

Reg. U. S. Pat. Off.

Reg. U. S. Pat. Off.

Samson Cordage Works

Boston, Mass.



COMPLETE OUTFIT

Hand and Foot-Power MACHINERY

Our No. 3 Wood Turning Lathe can be speeded from 1,000 to 2,000 revolutions a minute with perfect ease. Stopped or reversed at will of operator.

Write for Particulars

W. F. & Jno. Barnes Co. 74 RUBY ST., Rockford, Ill.

Parks Portable Shingle or Combination WOODWORKING OUTFITS

This machine is a combination of circular rip and cross cut saw, 6 or 12-inch jointer with tilting guide, boring attachment, jig saw with tilting table, sand disk, and gasoline engine, guaranteed to do the work.

Angle steel frame is the strongest structural material known. Machines are made in large quantities which allows us to sell at lowest prices and make prompt shipment. WRITE FOR CATALOG

PARK'S
Ball-Bearing Machine Co.
Fergus Street and C. H. & D. Ry., CINCINNATI, OHIO

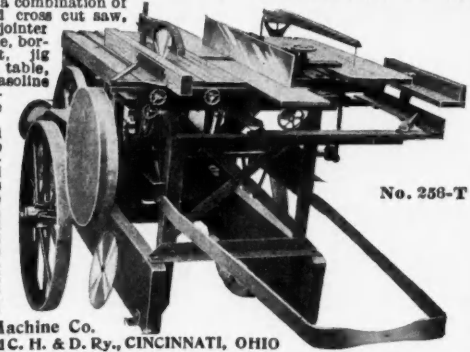

No. 258-T

are the most practical—the most efficient—the most economical woodworking equipment you can buy

You will get SPECIAL ATTENTION if you tell Advertisers you read American Carpenter and Builder.

SAVE 50 to 100 %

On Your Millwork and Carpentry with a 1914 MODEL FAMOUS "31" UNIVERSAL WOODWORKER—

Over 2,000 others save with
the Famous—why not you?

The **FAMOUS** "31"

Does 31 Kinds of Work

The handsome new
Catalog No. 12 for
1914 shows a machine
to fit every need of
the progressive Con-
tractor and Builder.

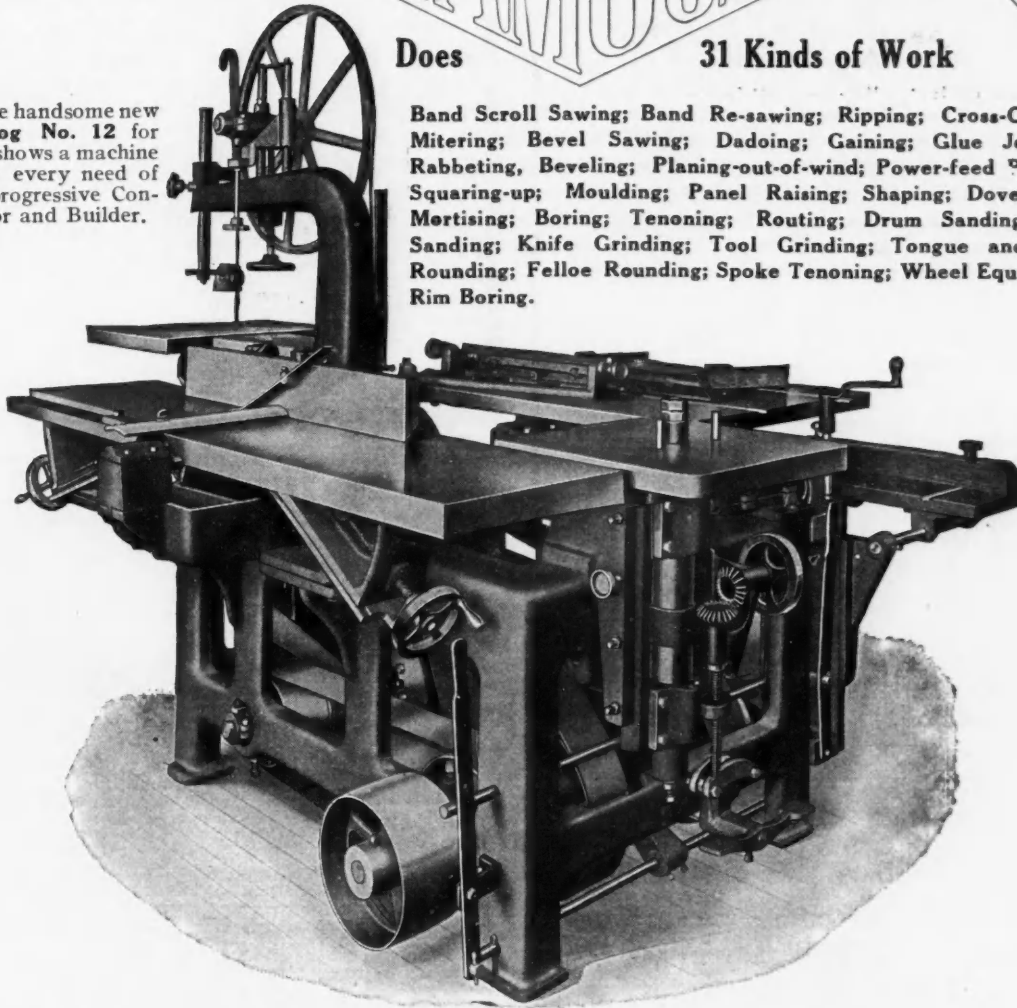

Band Scroll Sawing; Band Re-sawing; Ripping; Cross-Cutting; Mitering; Bevel Sawing; Dadoing; Gaining; Glue Jointing; Rabbeting, Beveling; Planing-out-of-wind; Power-feed Planing; Squaring-up; Moulding; Panel Raising; Shaping; Dovetailing; Mortising; Boring; Tenoning; Routing; Drum Sanding; Disc Sanding; Knife Grinding; Tool Grinding; Tongue and Pole Rounding; Felloe Rounding; Spoke Tenoning; Wheel Equalizing; Rim Boring.

The Famous "31" is furnished in any combination necessary to fit *your* needs; 27 or 32 in. Band Saw, 12 or 16 in. Jointer, Rip and Cut-off Saw Table, Shaper, Borer and other attachments to do up to 31 or more different kinds of work. Tell us what your wants are and get our proposition. Remember, we manufacture separate machines too.

FAMOUS THE SIDNEY TOOL COMPANY **FAMOUS**
Chief Offices and Factories SIDNEY, OHIO U.S.A.
AGENCIES AND DISTRIBUTING CENTERS THROUGHOUT THE UNITED STATES AND ABROAD

The Sidney Tool Co., Sidney, Ohio.
Send me your new 1914
Catalog No. 12 of Famous
Woodworkers and Separate Ma-
chines—and show me how to save 50
to 100% on my Millwork and Carpentry.
I am interested in.....
(State whether combination or separate machines, and what)
Name.....
Address.....
CUT HERE

You will get SPECIAL ATTENTION if you tell Advertisers you read American Carpenter and Builder.

What Percentage of the Contracts You Bid on Do You Get?

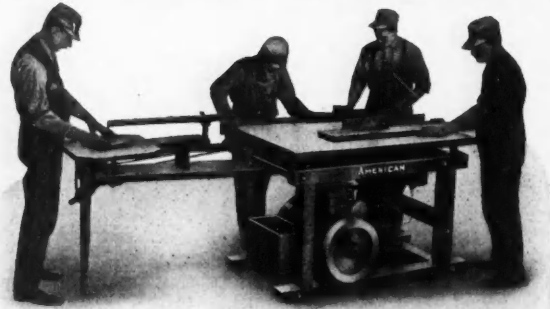

Note this exclusive "Four-Man" feature of the "American"

A contractor in New Jersey writes us: "I have lost only one of the jobs I bid on since I put in your ("American") Wood-Worker."

Here's a man who knows from experience just how much his "American" Wood-Worker will save him on his costs, and is able to under-bid his competitors by that amount.

Doubtless also, his customers take into consideration the fact that this man has an "American" Wood-Worker and will therefore do work just that much better and faster than the contractor who hasn't one.

As a result, this contractor has secured 99 per cent of the contracts he bid on. And he credits that showing to his "American."

Order **your** "American" **now**—and be ready to figure **right** on spring and summer business.

Send for the "American" Pamphlet No. 47.

American Saw Mill Machinery Co.

80 Main Street HACKETTSTOWN, N. J. 1360 Hudson Terminal NEW YORK CITY

LET US EQUIP YOUR SHOP AT SMALL EXPENSE

To have an up-to-date shop should be the aim of every carpenter. You keep the profits on your mill work then. It's not necessary to go to a big expense to put your shop on an equal footing with the average small planing mill.

Invest a little money in a Type "C" Woodworker which is really four machines in one. You don't get one machine with three attachments. Each machine is separate and distinct and can be so used.

You cannot buy better quality in any woodworking machine. The base is of heavy cast iron. The whole machine is as thoroughly reliable as any machine used in a planing mill. It is **Guaranteed For a Life Time**

Type "C" Woodworker Complete With Hollow Chisel Mortising Attachment \$152.50



Try a Woodworker for 10 Days FREE

Send us your order for any machine or part. Enclose the price with your order. The machine will be shipped with the distinct understanding that you may return it at the end of 10 days' trial if it is not satisfactory. We will return every penny of your money together with any freight charges you have paid. Or write us for particulars as to how you can buy this machine on time. Ask any bank about our reliability.

The Tannowitz Works
315 N. Front St.
GRAND RAPIDS, MICH.

BLAKE QUICK ACTING VISE

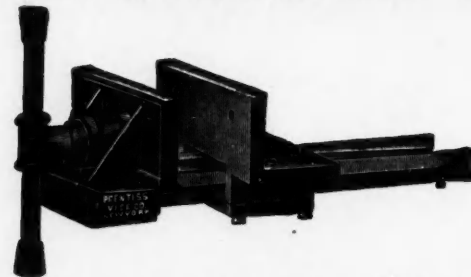

For Cabinet Makers and Wood Workers. Simplest—Strongest—Cheapest—Best
Send for Catalogue of all kinds of Vises
PRETISS VISE COMPANY, MAKERS
106-110 La Fayette St., New York, U. S. A.

Don't Ask the Dealer for Sash Cord. Ask for

"SILVER LAKE"

and see that he gives it to you. It is impossible to



substitute as our name is stamped on every foot of cord. Silver Lake Sash Cord is the Original Solid Braided Cotton Sash Cord, and has been the standard since 1868. No other is just as good.

You will get SPECIAL ATTENTION if you tell Advertisers you read American Carpenter and Builder.

**What You
Can Do on the
CRESCENT**

- Re-Sawing**
- Cutting Off**
- Tenoning**
- Moulding**
- Panel Raising**
- Knife Grinding**
- Mortising**
- Pole Rounding**
- Disc Grinding**
- Rabbeting**
- Boring**
- Grooving**
- Dadoing**
- Jointing**
- Band Sawing**
- Ripping**
- Sanding**

Work While You Wait

The carpenter who gets ahead meets his work half way. He anticipates the coming work. He is always half way ahead of the other fellow—the one who just waits. He gets to his profits quicker. "Work and Wait" is a good motto. To shut your eyes and trust to luck, or to "go it blind" as they say, will never get you anything.

PREPARE NOW FOR SPRING WORK

In the coming season you're bound to use doors, door and window frames, sash, mouldings, stair rails, spindles, newel posts, and all kinds of interior trim. Why not prepare a nice stock of these now? Then you cut out the planing-mill profits. You'll never be held up on a job waiting for material.

You can make all this stuff on the Crescent Universal Wood Worker. More than that, when the season is on, you can take the machine right out to the job and use it in a hundred ways to speed up and lighten the work.

THE CRESCENT UNIVERSAL WOOD WORKER

is a combination machine. The base is one single casting. This forms a steady, solid mounting for the various parts. The machine has five units,—band saw, jointer, shaper, saw table, and borer. Each unit is a separate machine and can be run separately or in a combination with any of the others. Other attachments can be added to make the Crescent adaptable as a re-saw, hand-feed molder, tenoner, panel-raiser, pole-rounder, disk-grinder, plain grinder, and hollow chisel mortiser.

Send for Free Catalog

The price of the Crescent is within reach of all. Whether you are a Carpenter, Builder, Contractor, or a general Repair Man, you can use the Crescent to increase your capacity and enlarge your business and profits.

Send for our fine 128-page Catalog. We want you to read it. It contains fine information on wood working machinery. The illustrations and descriptions of our wood-working machines will interest you.

CRESCENT
224 Main St.,

MACHINE CO.
Leetonia, Ohio

**Four Men
can Work
at the
Same
Time**



**Ask for
our Red
Catalog**

You will get SPECIAL ATTENTION if you tell Advertisers you read American Carpenter and Builder.

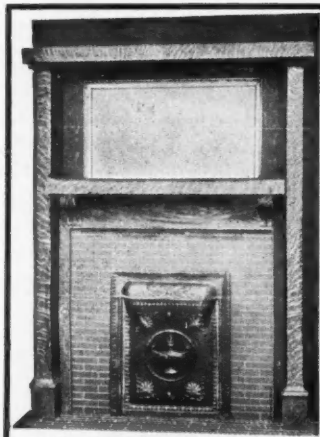

\$27.00 Our Price to You

For Mantel as illustrated with trimmings

Mantel is made of solid oak with 18x36 bevel mirror at price quoted we include any shade enameled tiling for facing and hearth, with recess grate and plated grate frame and front—Tile Facing 42x39 inches.

ILLUSTRATED CATALOGUE FREE ON APPLICATION

MOORMANN & OTTEN

611-613 Main Street

CINCINNATI, OHIO

MAKE MONEY

BY SELLING

FIRE PLACES



TILES and MOSAICS

for **FLOORS** and **WALLS**

Write for our Large Illustrated Catalogue of Fire Places in Tile, Wood, and Brick Andirons, Gas Logs, Consoles and Colonnades Sent Free on Request.

Write For Discounts to Carpenters and Builders

CHAS. F. LORENZEN & CO.

REAPER BLOCK

Cor. Clark & Washington Sts., CHICAGO

Send for the Catalogs that Interest You

We manufacture, import and sell, wood, tile and cement mantels; andirons; fenders, spark guards; the Jackson ventilating grate, heating on two floors; Franklin stove for use where there is no chimney; cleanout doors, ash dumps and dampers for fireplaces; Iron column plinth bases.

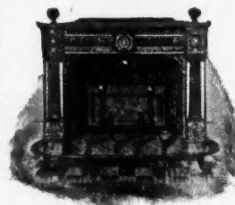

The Majestic coal chute for foundation walk.

Edwin A. Jackson & Bro., Inc.

51 E. Beekman Street

New York



\$20.00

in Yellow Pine, Oak or Birch, in the White.

Any size up to 8x8.

Freight paid to your station

This COLONNADE consists of Columns, Pedestals and Beam Brackets. The workmanship and materials are first class in every respect. We offer this colonnade for \$20 for a limited time only. Send your order today, give exact width and height of opening. State what kind of wood. F.O.B. Your Station.

Chicago Grille Works

828-838 Wells Street

Chicago, Ill.

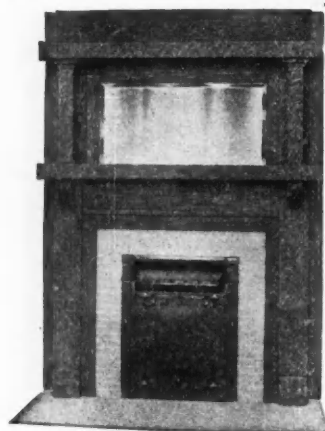

\$22.50 "From Factory to You"

For this elegant massive, selected oak or birch, mahogany finished mantel. Beveled Mirror 18x36

Price includes our "Queen" Coal Grate with best quality enameled tile for facing and hearth. Mantel is 82 inches high, 5 feet wide. Furnished with round or square columns, as shown in cut. Dealer's price not less than \$35.00.

Catalogue Free—Will send our 100 page catalogue, the finest ever issued, free, to carpenters, builders and those building a home.

CENTRAL MANTEL COMPANY

1247 Olive Street

:::

:::

St. Louis, Mo.

You will get SPECIAL ATTENTION if you tell Advertisers you read American Carpenter and Builder.

WRITE US

FOR OUR NEW
1914 CATALOG



AS PIONEERS in the manufacture of PORTABLE SAW RIGS, we are entitled to claim that we manufacture the BEST Portable Saw Rigs on the market today; in fact, we make them complete in five different sizes to meet every requirement of the trade.

We also manufacture hoists, pumps, elevators, mortar mixers, concrete chutes, air compressors, gasoline engines, etc.

Write Us for our new 1914 attractive Catalog

C. H. & E. MANUFACTURING CO., Inc.
322 Mineral Street MILWAUKEE, WISC.

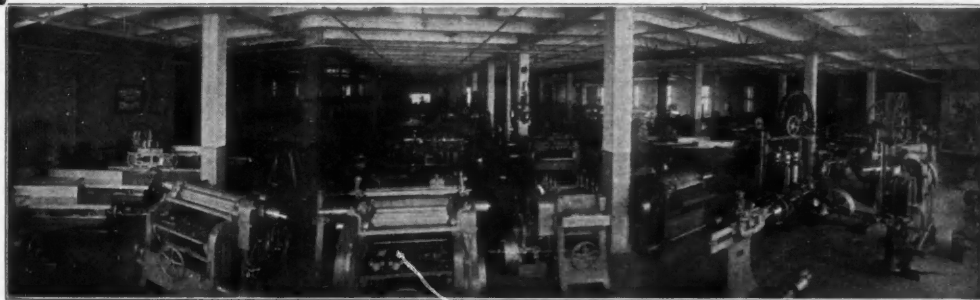

Section of Main Floor Exhibit and Salesrooms

Everything in wood working machinery and supplies for Contractors, Carpenters, Builders, Interior Finish, Sash and Door, Planing Mills, Furniture, etc.

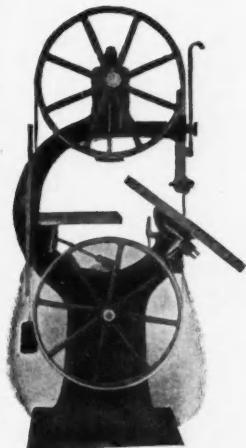

Chicago Band Saws
27-32-36 inch wheels

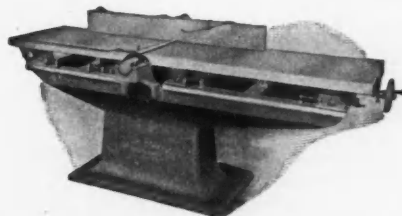

Chicago Jointers
8-12-16 inch

*Write us Your Wants
and Get Our Special Price*

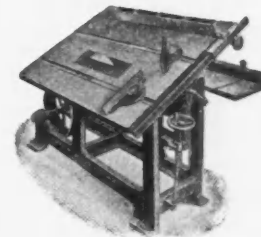

Chicago No. 9 Combination
Saw

Chicago Machinery Exchange
1215-1223 Washington Blvd. :: CHICAGO

You will get SPECIAL ATTENTION if you tell Advertisers you read American Carpenter and Builder.

MONARCH PATENT CORNICE MOULD

— the handiest tool for making all kinds of plaster cornices and corners. No trouble; no delay; works in one third the time it takes to mould cornices and corners the old way.

Consists of one blade holder, ten assorted blades and one blade scraper. Guaranteed not to rust or warp. Sent on 10 days free trial. If you don't like it you don't have to buy.

Ask for free descriptive circular.

TIMOTHY F. HORAN

10 Maple Street Cooperstown, N. Y.

CONTRACTOR CLEARS \$450 IN 10 DAYS

M. H. Ireland, Anamosa, Ia.

— Contractor — cleared above by using **LITTLE WONDERS**— What one man can do with Little Wonders you can do—Get next to this **LITTLE WONDER TRUCK**—It will triple your profits.

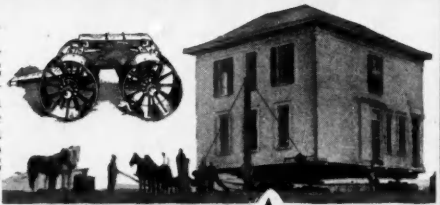

Here's the Little Wonder!

10 ROOM HOUSE 5 MILES 10 DAYS MOVED

Let us furnish your complete House Moving Equipment—everything from Little Wonder Trucks to rollers, jacks, etc. Get our catalog "B" right away. Don't delay. Just a post card brings it in a hurry.

HOUSE MOVERS SUPPLY COMPANY 620 Eastlack Court Cedar Rapids, Iowa

Queen Architects' Level

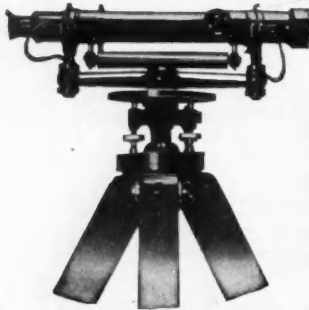

For Architects and Builders

A precision Level with high grade telescope, 12 inches long with sensitive bubble. Capable of doing the most accurate work. Moderate price. Send for catalogue.

QUEEN-GRAY COMPANY, 616-618 Chestnut St., Philadelphia, Pa.

It's Guaranteed!!!

White's Improved Level

is especially designed for work where a general-purpose level is required. Telescope is 12 inches long with magnifying power 25 diameters. Will detect an error of $\frac{1}{8}$ " in 300 feet. Shipped on approval to your address, express charges prepaid. Ask today for circular X giving price and full information—Ask today!!

DAVID WHITE COMPANY, Dept. C,
419 East Water Street Milwaukee, Wis.

"STERLING" Transits and Levels

MADE BY

Warren-Knight Co.



A line of instruments specially adapted to the needs of the Contractor and Builder!

Illustrated Catalogue S.W. upon request.

Special 10 days' trial offer this month.

Engineering and Drafting Supplies

136 N. 12th Street Philadelphia, U. S. A.
Successors to Izard-Warren Co.

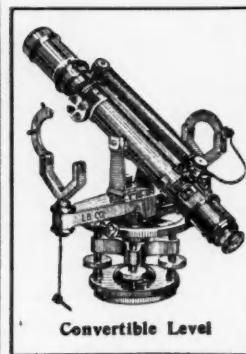

Convertible Level

BECKMANN INSTRUMENTS

are sold to give satisfaction. Our guarantee means Your Money Back if you want it.

Send for our Circular Y and let us know the work you are engaged in.

The L. Beckmann Co.

500 Adams St., Toledo, Ohio

—Established 1874—

Why Carry A Heavy Transit?

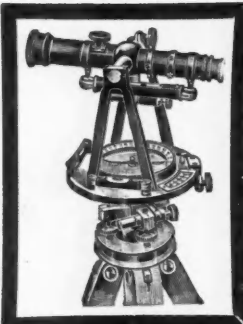

Architects, Contractors, and Builders, this is the serviceable instrument for you. A portable transit that is of special light design. It is easily carried and handled. Is thoroughly accurate and especially adapted for fast work. Built upon practical substantial lines. We manufacture a complete line of surveying instruments in various sizes and at a wide range of prices.

All instruments guaranteed by us. Our circular No. 27 will explain our instruments to you in detail. It will prove to you to get it before deciding upon any surveying instruments.

KOLESCH & COMPANY, 138 Fulton Street, NEW YORK
Surveying Instrument Makers. Established 1885.

INTRODUCTORY TRIAL OFFER

If the **SELF-SETTING PLANES** are not sold in your town and you write us saying, "I saw your trial offer in A. C. & B., we will send you particulars, a carpenter's pencil and our \$1.00 Certificate, which we will receive as \$1.00 in payment for a **SELF-SETTING PLANE** as stated in our \$1.00 Certificate, and if this **SELF-SETTING PLANE** is unsatisfactory and returned to us at our expense, we will send you \$1.00 more than you sent us, as the \$1.00 Certificate says.



As this paper guarantees we will do as our advertisement says, you know the plane must be O. K. ALL WE ASK is to have you TRY the **SELF-SETTING PLANE** on your own bench, in your own way, with or against the grain, on the **WORST** cross-grained oak, knurley, knotty, hard or soft wood you can find, THAT IS FREE FROM SAND OR DIRT. If it is not worth to YOU, OR YOUR MEN, TWICE ITS COST, return it at our expense as above stated.

If you send us the addresses of ten carpenters, no matter where they live we will send you another hard, tough carpenter's pencil.

Give the **SELF-SETTING PLANE** a chance to PROVE ITS WORTH, if it FAILS, return it and we will return your money.

Carpenter's Hard, Tough Pencils, 30c per dozen, postage prepaid.

GAGE TOOL CO., Vineland, N. J.

You will get SPECIAL ATTENTION if you tell Advertisers you read American Carpenter and Builder.

Framing Problems Solved

by the use of a tool made especially for carpenters and builders. It combines in one instrument the advantages of a steel square, bevel protractor, level, and pitch to foot indicator. It makes many hard problems in framing easy without resorting to figures. It is the

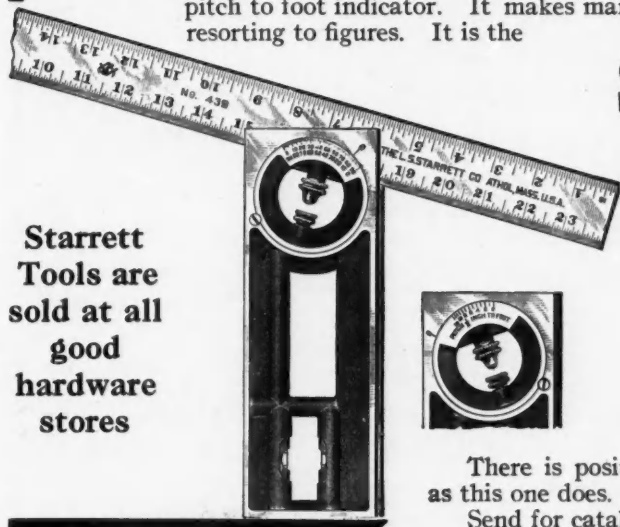

Starrett Tools are sold at all good hardware stores

Starrett Patent Builders' Combination Tool

It shows angles by degrees, pitch-to-foot by half inch, complimentary angles, etc. It may be used as a plumb or depth gage.

There is positively no one tool for carpenters that will do as much as this one does. Price, 18-inch, \$6.00; 24-inch, \$7.00. Send for catalog 206 showing full line of Starrett tools.

THE L. S. STARRETT COMPANY
World's Greatest Toolmakers
ATHOL, MASS.

42-214

23	22	21	20	19	18	17	16	15
LENGTH OF COMMON RAFTER PER FOOT	21 63	20 80	20 00	RUN	24 75	24 04	23 3	23 3
DIFFERENCE IN LENGTH OF HIP OR VALLEY RAFTER PER FOOT	2 1/4	2 1/4	2 1/4	CENTERS	3 1/4	3 1/4	3 1/4	3
FIGURES GIVING SIDE CUT OF JACKS	10 1/8	10 1/8	8 1/4	VALLEY RAFTERS	11 6	7 10	8	9
FIGURES GIVING SIDE CUT OF HIP OR VALLEY RAFTERS IN VALLEY OR HIP	18 10	18 10	14 8	SHEATHING	17 10	16 15	15	15

Every Carpenter

knows the ordinary lengths and cuts of rafters. It's the odd ones he cannot remember.

Our rule not only gives the length and cuts of rafters to frame the seven ordinary pitches of roof but it gives the length and cuts of rafters for

Seventeen Different Pitches of Roof.

Send for our little book explaining this rule. It's Free.

We manufacture the only practical Take-Down Square.

Nicholls Mfg. Co.
Ottumwa, Iowa

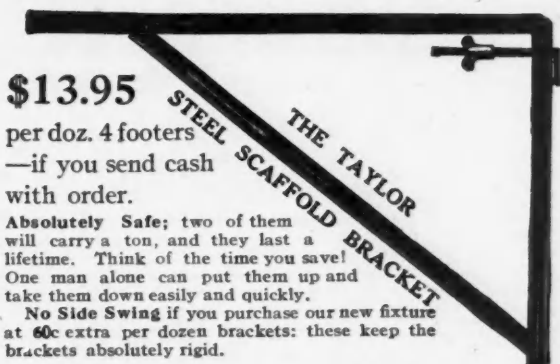

\$13.95

per doz. 4 footers
—if you send cash with order.

Absolutely Safe; two of them will carry a ton, and they last a lifetime. Think of the time you save! One man alone can put them up and take them down easily and quickly.

No Side Swing if you purchase our new fixture at 60c extra per dozen brackets: these keep the brackets absolutely rigid.

Write for Catalog of Builders' Specialties!



About clamps—the sliding jaw on each of ours can be moved in an instant **DIRECTLY AGAINST** the work operated on, so that half a turn of the fine specially threaded screw will apply the power.

Think of the time this saves!

The grip is positive, and special grade of steel in the bar more than doubles the strength of the clamp.

Our No. 10 catalogue shows some very interesting price reductions on four of the most wanted styles. It will pay you to write for it at once.

James L. Taylor Mfg. Co.
Poughkeepsie, N. Y., U. S. A.

You will get SPECIAL ATTENTION if you tell Advertisers you read American Carpenter and Builder.

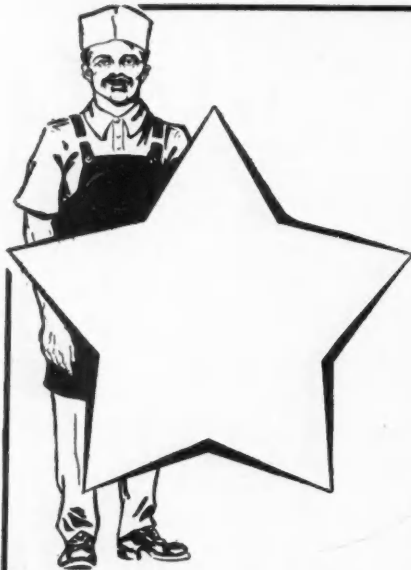

The Chuck Cannot Work Loose
in Our

Master Ratchet Brace

because firmly secured by a flat head screw and patent cup washer—a feature that will commend itself to practical men. These excellent features are also found in all our Braces of the better grades.

Do not be content with a brace that is always out of order, when you can get this one and get rid of your troubles once for all.

Write for details and complete Catalog.



MILLERS FALLS COMPANY

28 Warren Street

NEW YORK



“A Bit of Utility”



Guided by its circular rim—instead of its centre—the Forstner Labor-Saving Auger Bit will bore any arc of a circle, and can be guided in any direction. Doesn't matter how hard the wood is, no consequence whether it is full of knots, or the grain awkward to negotiate. The Forstner Bit works with equal smoothness under any condition and leaves a true polished surface on every job.

Unequaled for Delicate Work

Supercedes chisels, gauges, scroll-saws, or lath tools combined, for all kinds of delicate work. Cabinet and pattern makers and carpenters are enthusiastic because they do more work than other bits and cost no more.

We can offer something special in the matter of price on sets packed in a sensible box. Send today for particulars and catalog.

The Progressive Mfg. Co.
Torrington, Conn.

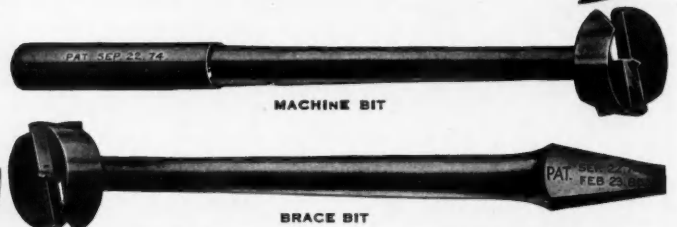

ROOF SLATES

STRUCTURAL SLATE BLACKBOARDS

You will get SPECIAL ATTENTION if you tell Advertisers you read American Carpenter and Builder.

E. J. JOHNSON

38 Park Row New York

Quarry Operator

BLACK, GREEN, PURPLE, RED

Booklet, Samples and Prices on Application

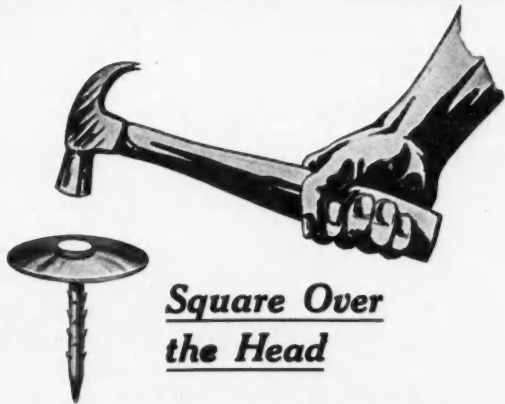

**Square Over
the Head**

SIMPLEX NAILS DRIVE STRAIGHT

The Shank extends THROUGH the Head. The hammer blow does not glance, as the blow falls directly on the head of the nail shank—not on the curved dome.

Trade **SIMPLEX** Mark
Reg. U. S. Pat. Office
ROOFING NAILS

Have four times the head area of so-called large headed wire nails; hence four times the holding power.
ONE PIECE—not two piece. Head cannot loosen.
Made in two sizes—1 inch and 1½ inch.
Insist that your prepared roofing be furnished with **SIMPLEX NAILS**. Free sample on request.

H. B. SHERMAN MFG. CO.
BATTLE CREEK MICHIGAN

STANDARD CLAMP



**A Steel Screw and a
Wide, Strong Frame are**

the two features which give the Hargrave Standard Clamps the utmost resistance to wear and failure.

These Clamps are just as carefully made as all of the Hargrave Tools.

Catalogue ?

Dept. H

THE CINCINNATI TOOL CO.
Norwood, Cincinnati, Ohio

**Stanley
Tools**

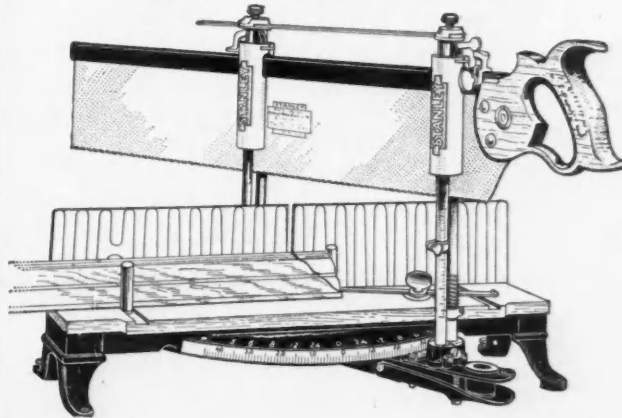

Stanley Mitre Boxes

STRONG—DURABLE—ACCURATE

A Few Striking Features

- Saw is held above work when not in use.
- Swivel is automatically locked at any angle.
- Two sockets in swivel for use of long or short saw.
- Narrow opening in back of frame, especially adapted for small work.
- Steel rod uprights for saw guides.
- Uprights adjustable for saws of varying thicknesses and for those that run out of true.
- Stock guides for holding work in place.
- Extra wide range of work—will saw at angle of 30 degrees.
- One-Piece frame with detachable Malleable iron legs.
- Construction thoroughly mechanical; all parts interchangeable and readily replaced if lost.
- Quickly and easily put together or taken apart for carrying.
- A specially made back saw furnished with each box.

SEND FOR SPECIAL CIRCULAR

ADDRESS

STANLEY RULE & LEVEL CO.
NEW BRITAIN, CONN. U.S.A.

You will get SPECIAL ATTENTION if you tell Advertisers you read American Carpenter and Builder.

MAYHEW

NAIL SETS and PUNCHES

No. 435



Should be in every Kit

No. 437

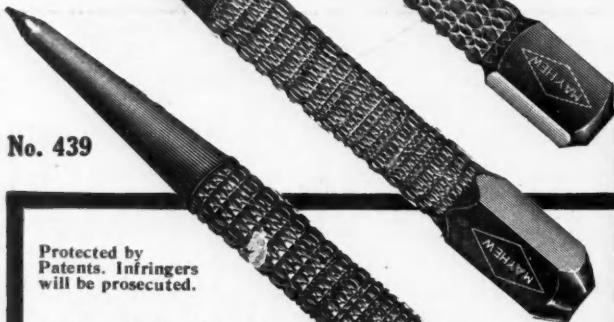

No. 439

Protected by Patents. Infringers will be prosecuted.

No. 435, Nail Set

a strictly new, high quality tool. Hand-forged from the finest crucible steel electrically tempered. Each set is warranted. The finely knurled body is easy for the fingers, and the $\frac{3}{8}$ " square head prevents tools from rolling off the bench. Length, 4 inches. Points $\frac{1}{32}$ ", $\frac{2}{32}$ ", $\frac{3}{32}$ " and $\frac{4}{32}$ ".

No. 437, Center Punch—another reliable tool, hand-forged from the finest crucible steel, electrically tempered. A companion to No. 435 Nail Set, with the same square head and knurled body. Length 4 inches.

No. 439, Prick Punch—construction identical with No. 437 Center Punch, except for the point. Fully warranted. Length, 4 inches.

In addition to the above tools, we especially desire to call the attention of all carpenters, builders, and cabinet makers to Hand-Forged Nail Set No. 434, another of our new tools. Also Solid Punch No. 490, and Center Punch No 491. The diameter of stock in these punches is $\frac{1}{2}$ ". Points are at a correct angle to stand hard usage. Diameter of points of Solid Punch from $\frac{3}{32}$ " to $\frac{12}{32}$ ". These punches, as well as Prick Punch No. 492 and Pin Punch No. 493, have our new embossed hand hold. Prevents tool from slipping or turning in the hand.

These tools are accurately described and illustrated in our new Catalog No. 14, which is sent free on request. Write us. If your hardware dealer does not sell Mayhew Tools, write us and we will see that you are supplied.

H. H. MAYHEW CO.,
Shelburne Falls,
MASS.

C. E. JENNINGS & CO'S

71-73 MURRAY ST., N. Y., U. S. A.

TRADE MARK.

COMBINATION SET OF SAWS No. 131

This set of saws is just what you need. Takes up very little room in the kit and is less expensive than if you bought all the saws separately.

Each blade is fully backed by our guarantee both as to quality and workmanship. The saws are hand-forged from extra refined spring steel, hand filed and set. Warranted to hold edge and set for longest possible time and to run smoothly and easily.

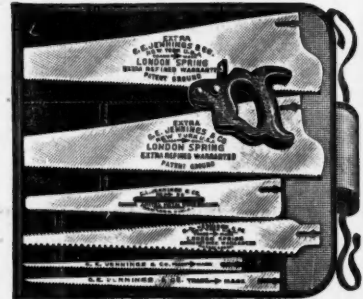

An adjustable lever in the handle operates the screw that holds the blade. Blades may be removed from the handle instantly and another blade substituted. Blade is held firmly and evenly.

Combination Set No. 131 consists of:

- 1—Garland Adjustable Handle
- 1—18-inch Hand or Panel Saw
- 1—18-inch Rip Saw
- 1—16-inch Double Edge Pruning Saw
- 1—15-inch Hack Saw
- 1—14-inch Compass Saw
- 1—12-inch Keyhole Saw

A Waterproof Canvas Case for this set with seven pockets—one for each blade and one for the handle, will be furnished at a slight extra cost.

Ask your hardware dealer to show you Set No. 131. It is so handy and the price so reasonable that you'll like it. Write us for new Catalog of guaranteed tools.

LANE'S TROLLEY

Parlor Door Hangers and Track

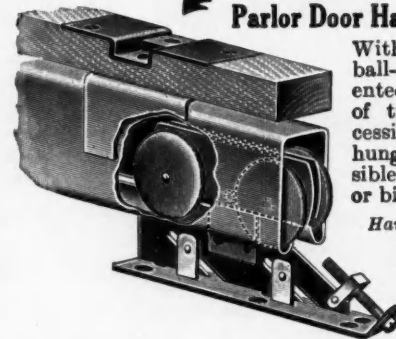

With bicycle quality ball-bearings and patented side adjustment of track (readily accessible after it is hung) makes it impossible for door to scrape or bind.

Have you our Catalog?

LANE BROS. COMPANY
Cherry St.,
POUGHKEEPSIE,
N. Y.

Lacey (Patented) Silo Doors and Silo Hoops

make silo building easy. You can build better silos for less money by ordering your Doors and Hoops from my factory and buying the rest of the material in your own town. My doors and hoops will save you time and money on all silo work. Your order will receive individual attention. Prompt shipment and Freight Prepaid to any point east of the Mississippi.

Write for my Free Circulars and Silo Book. This book will give you some good pointers on silo construction. Ask for it. Costs you nothing.

Elmer B. Lacey, Endicott, N. Y.

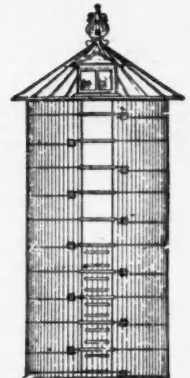

You will get SPECIAL ATTENTION if you tell Advertisers you read American Carpenter and Builder.

With these "Yankee" Tools

you can drive or draw a screw 3 feet over head, in tight corners or most any other place out of reach. Besides this, you get the same service as with the famous No. 30, which you doubtless now have in use. The No. 130 "Quick Return" shown here has a spring in the handle which quickly drives the spindle back for the next stroke.

Add the Screw Holder shown here and you see at once what a tremendous advantage you have in this tool, especially in over head work.

With these two Tools you can hold the work in one hand while you start and drive the screw in some place out of reach with the other. For all convenient and close range work this is the quickest "Yankee" Screw Driver we have yet put out.

If your dealer cannot supply you, we will mail you the two for **\$2.25**

Write us for the "Yankee" Tool Book. It tells about every tool we make. A postal brings it.

NORTH BROS. MFG. CO.

PHILADELPHIA, PA., U. S. A.

Dept. A

RELIABLE and SAFE

The Sebco method offers the only absolutely dependable means of attaching railings, gratings, iron doors, window frames, pipes, shafting, machinery, electrical apparatus and plumbing fixtures of every description.

SEBCO

Expansion Bolts and Screw Anchors assure quicker, neater and more substantial work.

Our catalog illustrates and describes many different ways of attaching fixtures that you should know about.

We will also send you Samples Free.

STAR EXPANSION BOLT CO.

147 Cedar Street
NEW YORK

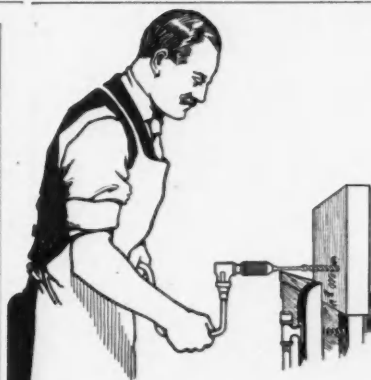

Satisfaction

When you get tired of using bits that clog in the thread, that choke with chips, and that don't bore true, try a set of

Russell Jennings

Auger Bits

and see if you don't get satisfaction. We know you will. They are the only bits made of genuine crucible steel and they are made right for all kinds of boring. Don't forget the Precision Turned Shank Bit which cannot pull out of the chuck.

Our bits are sold at all good hardware stores.

Russell Jennings Mfg. Co.

Chester, Conn.

21-123

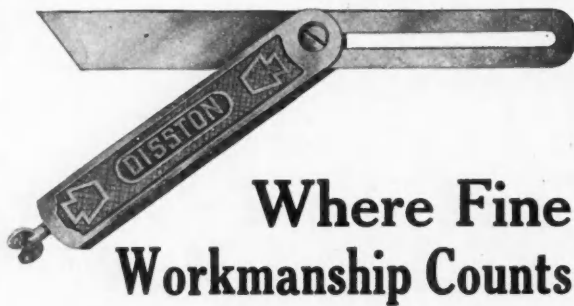

Where Fine Workmanship Counts

The very simplicity of this kind of tool leads many to bestow less care upon its manufacture. Not so in the Disston Works. Every detail of every tool receives the same care and attention in its manufacture. Whether a man here makes bevels, trowels, saws, plumb and levels or any other tool, he is equally skilled in his work. We demand the same perfection in finishing this tool as we do in any other. A line drawn by its aid will be as accurate as it is possible to make. You can always "Depend on Disston".

This DISSTON Bevel

contains a patented feature which alone makes it superior to any other. There is a ball bearing in the end of the iron stock. Turning the wing nut forces this ball against the screw that passes through the blade and holds blade firmly. A half-turn tightens it. When the blade is extended to its full length—the greatest test of all—the ball bearing holds it as solid as in any other position.

The DISSTON Bevel is practically indestructible and is absolutely accurate.

HENRY DISSTON & SONS

Incorporated

Keystone Saw, Tool, Steel & File Works
PHILADELPHIA, U. S. A.

THIS GUARANTEE Protects YOU

We guarantee Vanadium Saws and if at any time they prove defective, we authorize the dealers to exchange them for new ones.

16 in. 18 in. 20 in. 22 in. 24 in. 26 in. 28 in. 30 in.
\$1.60 \$1.80 \$2.00 \$2.15 \$2.30 \$2.50 \$2.70 \$2.90 each
Straight or Skew Back, In Hand, Panel, Ship Carpenter or Rip—any Teeth Desired



VANADIUM SAWS "Smile at Nails"

REMEMBER THIS

if your hardware store does not sell Vanadium Saws, we will send you one by parcel post. Tell us what kind of a saw you want. Try it out. Give it the hardest service you can think of.

Vanadium Saws are tougher but they're as easy to file and set as an ordinary saw. The hang and set is perfect. An easy saw to work with.

Don't hesitate to try a Vanadium Saw. If it doesn't make good on every claim, we'll return your money. Read our ads in the November and December issues of the A. C. & B. Write us now for description and price list.

PENNSYLVANIA SAW CO.

Betz Bldg.
PHILADELPHIA, PA.

Factory
FRACKVILLE, PA.

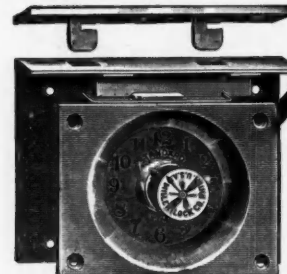

No. 3380
All Brass

Size 4"x3"

LAUGHS AT LOST KEYS

Here's the lock for your tool chest or your shop cabinets. Safe as a bank. No keys to lose. Locks automatically. A few turns of the knob opens it. Made of brass and fits all chests from 1/2" thick and up.

"Standard Time" KEYLESS CHEST LOCK

will prevent the theft of your tools. You are the only one who can open the lock. Price very reasonable. Can you afford to be without this strong protector for your valuable tools? Of course not.

Write for Keyless Lock Catalog

Miller Lock Co., Frankford, Philadelphia, U. S. A.

Huther Bros. Patent Groover or Dado Head

Will Save Its Cost in Three Days' Time

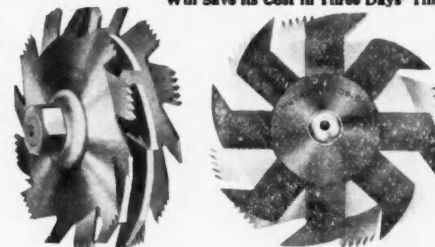

Showing Arrangement of Cutters

Can be used on any Circular Saw Mandrel.

For cutting any width groove from 1/4" to 2" or over. Will cut a perfect groove, either with or across the grain, and leave edges smooth. Will ship to any responsible firm on ten days' approval; if not satisfactory you are

at liberty to return at our expense. We also make a specialty of concave ground smooth cutting circular Mitre Saws, for either rip or cross cut; Grooving Saws for all kinds of special work; Lock, Corner Cutters, Concave Saws, etc.

Try our Scraper Blades and you will use no others.

HUTHER BROS. SAW MFG. CO., 1101 University Ave., Rochester, N. Y.

You will get SPECIAL ATTENTION if you tell Advertisers you read American Carpenter and Builder.

WHEN TOOLS GET TIRED

There are times when edge tools need refreshing.—Bring them back to a keen-cutting edge on a

Carborundum Niagara Grinder

These little machines are fitted with Carborundum wheels and a practical tool rest.—It takes but a jiffy to grind the tool true and keen—then a couple of rubs on a Carborundum Sharpening Stone and the tool is ready for service. Carborundum Niagara Grinders are sturdy, durable, mechanically simple, machines—smooth running, high speeded—nicely finished—genuinely serviceable.



*Made in several sizes, for tool-kit or work-bench.
Ask your hardware man.*

THE CARBORUNDUM COMPANY, NIAGARA FALLS, N. Y.

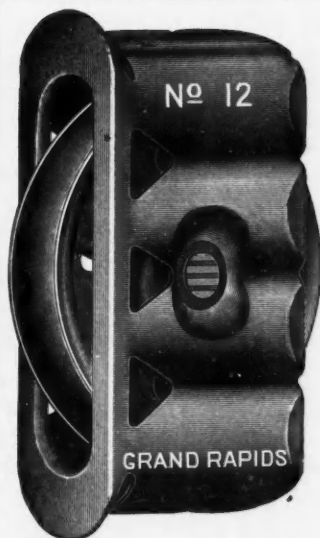

"GRAND RAPIDS" ALL STEEL SASH PULLEYS

**No Nails No Screws
Just Bore 4 Holes**

The time saved by the "Grand Rapids" will actually pay for the pulleys.

You can't afford to use old style pulleys.

Write for free samples and prices.



Grand Rapids Hardware Co.
Manufacturers
158 11th Street, GRAND RAPIDS, MICH.

This fastening is more secure than any number of screws or nails could make it. Saves about 15 per cent, too.
S C R E W S
C O S T M O N E Y

MONITOR SASH LOCKS



(PATENTED)

NEVER BREAK

BECAUSE THEY ARE MADE OF VERY HEAVY GAUGE METAL AND PERFECTLY CONSTRUCTED.

If the upper plate drops, the Monitor "Never Break" Sash Lock will pick it up from a lower point than any other, adjust the sashes perfectly, prevent all vibration and lock securely, so it cannot be opened from the outside.

MADE IN TWO SIZES AND ALL FURNISHED BY

The Champion Safety Lock Co.
Geneva, Ohio

You will get SPECIAL ATTENTION if you tell Advertisers you read American Carpenter and Builder.

"OHIO EXTRA" AUGER BITS

are High Grade Single Twist Bits, carefully made from specially selected auger bit steel. They are the Most Rapid and Cutting and Perfect Clearing Bits on the market today and are fully warranted.



"OHIO" CHISELS, PLANES, ETC.

All "Ohio" Tools are made with the same painstaking care that has built up our present reputation for making only high grade tools. We use in our Edge Tools high grade steel, treated and tempered by the most improved process, which insures Uniformity and Correctness of Temper, and a Keen, Tough and Lasting Cutting Edge. If you appreciate Good Tools it will pay you to insist on having "Ohio" Tools from your Dealer.

Write for our special Carpenters' Catalogue of High Grade Tools and Benches

OHIO TOOL CO. (Dept. 15) Columbus, O.



REGISTERED



BONDED vs. GUARANTEED TOOLS

Red Devil "Bonded" Tools are Insured Tools

They are insured for TWO YEARS. A signed Bond Policy packed with each tool. Learn for yourself the vast difference between simply guaranteed tools and Bonded tools. Your dealer has Red Devils. If not, we will send one sample only of Red Devil Bonded No. 2622, one inch, Beveled, Socket Firmer, Pocket Chisel, with leather tipped handle, on receipt of 50 cents in coin or stamps.

The stamp of "Red Devil" on a tool means the "O K" of the largest manufacturers of mechanics tools in the world, and you'll never find that stamp on a poor tool.

Write for Booklet of 3000 Red Devils

151 Chambers Street
NEW YORK CITY

SMITH & HEMENWAY CO.

140 Lemoine Street
MONTREAL, CAN.



RED DEVIL AUGER BITS - Made to Exact Size - Special Grade Tempered Steel
POCKET LEVELS - Absolutely Perfect - Nickel Plated

RELIABLE FOLDING Scaffold Bracket



Strong and safe; requires only a few minutes to attach. No holes to bore. Four 10-d or 16-d nails fasten them securely. Positively rigid; no vibration.

The Low Price of these Brackets can be saved in time and material on the first two jobs.

ELITE MFG. COMPANY
100 Ohio Street ASHLAND, O.

Shultz Corner Posts For Store Fronts

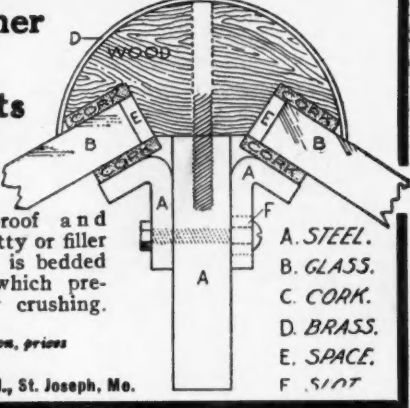

make a strong, handsome and practical joint. They are water-proof and dust-proof and never rot. No putty or filler is used. The glass is bedded on Spanish cork which prevents cracking or crushing. Not expensive.

Write us for description, prices or estimates.

All Steel Corner Post Co., St. Joseph, Mo.

A. STEEL.
B. GLASS.
C. CORK.
D. BRASS.
E. SPACE.
F. SLOOT

CALDWELL SASH BALANCE



Does away with weights and cords, and VASTLY more durable.

Makes sashes work perfectly.

Permits greater window space in new work, as box frames are not necessary.

May be applied to old windows without altering sashes or frames.

Write for circular to the

Caldwell Mfg. Co.
15 Jones Street, - Rochester, N. Y.

GOODSELL MITRE BOX

Made of STEEL - Cannot Break

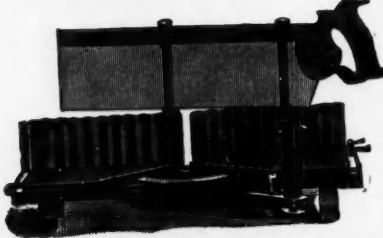

First in Quality and Improvements Automatic Steps for holding up saw. Corrugated Backs Graduated. Gauge for duplicate cuts and many other features

Send for Circular "C"

GOODSELL MFG. CO., Greenfield, Mass.

You will get SPECIAL ATTENTION if you tell Advertisers you read American Carpenter and Builder.

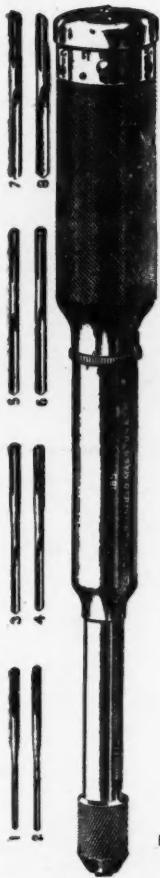

The Holes in the Handle

are drilled the size of the drill points inside, forming a gauge by which the size of drill required can be ascertained instantly.

Holes in Wood

brass and iron are easily and rapidly drilled by our

185 AUTOMATIC DRILL

Goodell-Pratt Company

Toolsmiths

Greenfield, Mass., U. S. A.

1853



BROS.

1913

Fine Beveled Edge Shank and Socket

Chisels



Tang and Socket Butt Chisels

Plain and Beveled Edges

Send for illustrated Catalog

Buck Bros., Millbury, Mass.

Architects—Contractors—Builders

Perhaps you do not use a steel tape often, but one would come in handy many times, wouldn't it? And occasionally you need one badly, and an accurate one, a

LUFKIN STEEL TAPE

Our tapes embody many exclusive features and are guaranteed to give complete satisfaction.

CATALOG ON REQUEST

THE LUFKIN RULE CO. Saginaw, Mich. New York

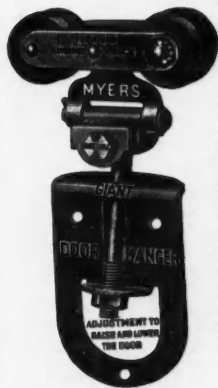

THE MYERS GIANT ADJUSTABLE TANDEM DOOR HANGER

for TUBULAR GIRDER TRACK is adjustable to and from the building, and up or down as necessary. Has flexible engine track with steel rollers revolving on steel roller bearings. The adjustable features prevent trouble from weather conditions or sagging of building. Storms, sleet or ice do not affect it, owing to complete protection afforded by the tubular track. Track and Hanger are constructed to carry and operate heavy doors easily.

This and other styles of Tubular and "Stayon" Door Hangers are shown in our Door Hanger Booklet. Copy mailed on request.

F. E. MYERS & BRO.
ASHLAND, OHIO

"Last a Lifetime and Give Satisfaction To the End"

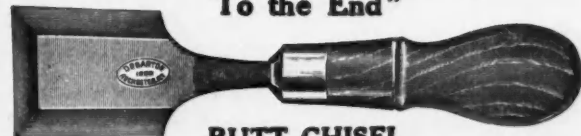

BUTT CHISEL

TRADE MARK



The celebrated Barton Planes and Edge Tools for carpenters and all other woodworkers are unequalled by any other made for keen, hard, smooth cutting edges. If your hardware dealer does not handle

THE CELEBRATED BARTON TOOLS

Send direct for catalogue and our free story book, True Stories. Be sure to specify "CARPENTER'S CATALOGUE."

MACK & COMPANY, 30 BROWN'S BACE ROCHESTER, N. Y.

You will get SPECIAL ATTENTION if you tell Advertisers you read American Carpenter and Builder.

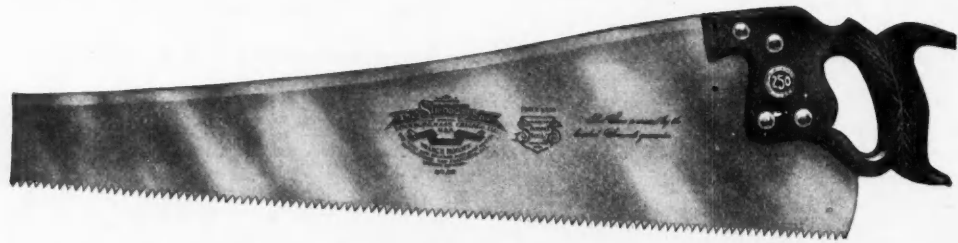

BUY A GOOD SAW—THE SIMONDS SAW

A GOOD saw costs money but no more than it is worth. For \$2.50 you can get a Simonds Blue Ribbon Hand Saw 24" or 26" length, either Cross-Cut or Rip, and any number of points you may desire. This saw is made of Simonds' Special Crucible Steel, is absolutely guaranteed against every defect, is taper ground for greatest clearance, cuts with the least amount of set, has a highly finished blade and a handsomely carved apple wood handle.

Your dealer can get you one of these saws or it will be sent to you upon receipt of price if your Dealer does not have them.

Simonds Manufacturing Company

Fitchburg, Mass.	Chicago, Ill.	Montreal, Que.
New York City	New Orleans, La.	Seattle, Wash.
Portland, Ore.	San Francisco, Cal.	London, Eng.
Vancouver, B. C.	Lockport, N. Y.	St. John, N. B.
Memphis, Tenn.		Spokane, Wash.

SARGENT

OUR new Rafter Square, No. 500R, is the most complete Square ever made for the carpenter.

It contains accurate measurements for all kinds of rafters, common, hip, valley, jack and cripple—in the most convenient form.

For full description and directions for using send for the Sargent Square booklet, free on request.

These measurements are all given on the Square; they are complete, correct and final. They save the trouble of multiplying and dividing and then obtaining a result about which there is some doubt.

Simple and easy to use. A great time saver.

SARGENT & COMPANY
Makers of Squares, Planes and Mechanics' Tools
1149 Leonard St. New York

Other Sargent Quality Tools are described in the Sargent Tool Book, a handbook for mechanics, sent on application.

You will get **SPECIAL ATTENTION** if you tell Advertisers you read American Carpenter and Builder.



Twenty-five Tons of Paper in One Issue of "A. C. & B."

GENERAL MANAGER ISSUES INTERESTING STATEMENT

MANY of the 40,000 readers of the AMERICAN CARPENTER AND BUILDER know that it is the largest and most widely circulated publication going to the building industry; but few of them have any idea of the great quantity of paper used and of the mechanical work of issuing each number.

Our printer's reports covering our January, 1914, number show that it took 414 reams of paper for the body or "inside," and 21 reams and 50 sheets for the covers. Each ream of "inside" stock consists of 500 sheets of paper measuring 37 x 49 inches and weighs 115 pounds. The "cover" stock consists of 500 sheets of paper measuring 25 x 38 inches and weighs 100 pounds; accordingly, there were used 207,000 sheets of "inside" stock, weighing 47,610 pounds, and 10,550 sheets of cover stock, weighing 2,110 pounds, or a grand total of 49,720 pounds, or 25 tons, less 280 pounds, or nearly *two carloads* of paper!

Each sheet of "inside" stock will print 32 pages of the AMERICAN CARPENTER AND BUILDER and each

sheet of cover stock will furnish four complete covers. It therefore took 5 sheets of "inside" stock and a quarter of a sheet of "cover" stock to make up each copy of the January number.

In printing, only 16 pages of the inside can be printed at once, so each sheet must go through the press twice, making a press run of 417,000 revolutions for the "body" or inside of the magazine. Four covers can be printed at once, but as there are two colors on the cover this necessitates two impressions to each sheet of cover stock, making a press run of 21,000 revolutions, or a grand total of 438,000 press revolutions.

The above figures are exclusive of the two-page insert furnished us already printed by one of our advertisers in the January number.

Very cordially yours,

General Manager, AMERICAN CARPENTER AND BUILDER.

Contents for February, 1914

Page	Page	Page
Adventures in Heating..... 76	Freezing Weather no Bar to Concrete Work..... 58	Pay-Dirt in His Own Trade..... 40
Advise People to Build Now..... 71	Fun and Prizes for Those Who Read Our Ad. Pages..... 42	Porch Details, Terra Cotta..... 68
Another Form of Threshold..... 81	Garage Door Problem..... 74	Power Equipment Used..... 38
Asks About Building Lines..... 83	Gets Over North Country on Motorcycle..... 80	Practical Carpentry..... 57
Base, Band, Belt, and String Details..... 68	Good Work Exhibited at New York Trade School..... 41	Prize Winners in Dec. Ad. Puzzle Contest..... 41
Bigger Building Business Predicted..... 37	Heavier IBeam Needed..... 87	Progress at Panama-Pacific Fair..... 44
Brick Wall Construction..... 85	He Doesn't Care for the Forestry Dept..... 80	Public Buildings..... 63
Builders' Alphabet—Part Three..... 43	He Kicks on Fireplace..... 81	Reinforced Concrete Columns—Talk No. 19..... 69
Builders Hardware..... 74	Helps to Bigger Business..... 72	Rules for Removing Concrete Forms..... 62
Carpentry Estimating—Basis 30 Cents..... 85	His First Round Barn..... 82	Salt and Calcium Chloride in Concrete Work..... 60
Charts for Figuring Steam and Hot Water Radiation..... 76	Home Builders Section..... 50	School Building at Burnham, Ill..... 63
Concrete Construction..... 58	Home Workshop..... 73	Seven-Room Gambrel Roof Cottage..... 52
Concreting—How to Prevent Damage from Cold..... 59	Hot Water Heating Chart..... 76	Six-Room Cement Plaster Bungalow..... 51
Connecting up Steam Generator..... 77	How Many Agree with This?..... 80	Six-Room Paneled Stucco Dwelling..... 53
Contest—"Importance of Good Appearance"..... 41	How to Do Work Fast—Setting Door Jamb..... 57	Six-Room Story and a Half Cottage..... 55
Contractors and "A. C. & B." Advertising..... 39	How to Make a Roman Seat..... 78	Stair-Work Question..... 87
Contracts Handled Last Year by Our Folks..... 38	Interest in Metal Lath Shown..... 41	Steam Heating Radiator Chart..... 76
Cornices and Brick Cornice Washes..... 67	Keep up the Good Work, Boys..... 41	Steel Square..... 64
Correction..... 84	Lath Stains on Plaster..... 85	Steel Square Question Box..... 65
Correspondence Department..... 80	Length and Cuts for Uneven Pitches..... 65	Store Front Details..... 67
Dome Lamp Stand and Lamp..... 79	Little Stories of Success..... 40	Strength of Douglas Fir..... 86
Dressing Table Seat, How to Make..... 78	Makes Fine Mahogany Furniture..... 84	Teach Your Boy to Make Things..... 39
Editorial..... 37	Measured Details of Colonial Porch..... 49	Terra Cotta Talks..... 66
Eight-Room Brick Residence..... 54	Method of Quarter Sawing..... 86	Thinks Licensing Builders Would Hurt..... 81
Experience with Dealers..... 87	Model Home Designs..... 50	Three Sq. Miles of Building under Way at Panama..... 44
Facts Brought Out by Census of "A. C. & B." Readers..... 38	My Side Hill Shop and its Equipment..... 72	Trade Notes and Items of Interest..... 88
Forecast of 1914 Building Business..... 38	New York Barn Building..... 85	Trisecting Angles..... 87
Found His Eldorado in Denver..... 40	Noon Hour Talks by the Boss Carpenter..... 69	We Discover the Great Advantage..... 66
Framing for Church Shed..... 87	Outside Light Necessary..... 86	What is the Pitch of the Roof?..... 84
		Yours for Safer Building..... 69

CHICAGO

SPRING BUTTS

REPUTATION

Do you specify a spring hinge with distinctive features which will appeal to your client and assure satisfaction to all concerned?



Chicago "Relax" Spring Hinges

are in great demand. They are substantial in construction and readily applied. The EXCLUSIVE FEATURE of spring action release, allowing the door to be placed at any desired position and automatically re-engaging when the door is closed, is of recognized merit and utility.

Send for Catalogue C 29. It fully illustrates and describes the most complete line of Spring Hinges manufactured.

Chicago Spring Butt Company

CHICAGO  NEW YORK

Yes! the World does Move!

Facts are Stubborn Things



Don't Buy
SPRING HINGES
OF
OBSOLETE
CONSTRUCTION



ONLY

Bommer

DOUBLE ACTING

Spring Butt Hinges

Carry the load on the true bearings

and look alike at both sides of the opening when both doors of a pair of doors are opened in or out. The carpenter can scribe for both doors of a pair from the same side, and avoid guesswork, as he can see what he is doing while fitting the doors.

YOUR HARDWARE MERCHANT CAN SUPPLY THEM

Bommer Bros., Manufacturers Brooklyn, N. Y.

Cabot's Sheathing and Deadening Quilt



The Cold-proof, Heat-proof, Sound-proof and Fire-retarding Lining

"Quilt" is a matting filled with dead air spaces, and one layer is as warm as twenty-eight layers of common building paper. A house lined with it will always be warm and save coal. Floors and partitions lined with it will stop the passage of sound. Roofs lined with it will keep cool in summer and prevent heat from escaping in winter. It will save coal enough to pay for itself every two winters as long as the house stands.

Send for a sample and catalog.

SAMUEL CABOT, Inc., Manufacturing Chemists, Boston
24 W. Kinzie St., Chicago - 1133 Broadway, N. Y.
Cabot's Creosote Shingle Stains; Stucco and Brick Stains, Conservo Wood Preservative.

The Morrill Saw Set



A mechanically perfect Saw-Set made with a rotatable anvil that is gauged so as to set any saw not over 16 gauge. The gauge screw and check nut insure the right angle and uniformity of set. It will take the wrong set out of a saw and put in the right set at one operation. Look for the Trade Mark Apex.

For 30 Years the Standard

Send for FREE Booklet "Saw Points"

CHAS. MORRILL 94 Lafayette St., New York

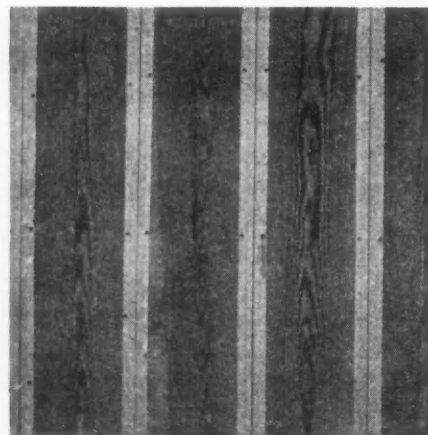

METALLIC BATTEN STRIPS

PRACTICAL—EVERLASTING—ECONOMICAL

These Batten Strips of Galvanized Metal will never warp, split, or draw away from the boards. Offer no obstruction to sliding doors. Allow for expansion and contraction of the siding. Made in 8-foot and 10-foot length with interlocking joint. Easily cut; no waste. Nailed directly to siding with small nails.



End view showing joint closed. A perfect fitting Batten at all times, in all weathers. Beautifies any building.

End view showing joint open. Provides for expansion or contraction of the siding so nails will not work loose.

Metallic Batten Strips make strong, neat joints. They make the building wind-proof, weather-proof and rat-proof. Also valuable for lining grain bins or wagon boxes.

Write for Free Sample and see for Yourself

METALLIC BATTEN COMPANY Owensville, Indiana

You will get SPECIAL ATTENTION if you tell Advertisers you read American Carpenter and Builder.

FEB 11 1914

Copyright 1914 by American Carpenter and Builder Company



The
**World's Greatest
Building Paper**

Important Notice

When your subscription expires, renew at once, using the blank enclosed in your final copy. If it expires with this issue your renewal must reach us before February 25 to avoid missing the March number. Use P. O. or Express Money Order if possible, but bills or 2-cent stamps may be sent at our risk.

The
**World's Greatest
Building Paper**

American Carpenter and Builder

Entered as second-class matter July 1, 1905, at the postoffice at Chicago, Ill. under the act of Congress of March 3, 1879.

Published on the first day of each month by

AMERICAN CARPENTER AND BUILDER COMPANY
RADFORD BUILDING, 1827 PRAIRIE AVE., CHICAGO

EDITORIAL DEPARTMENT

WILLIAM A. RADFORD, *Editor-in-Chief*
BERNARD L. JOHNSON, B. S., *Editor*
WILLIAM REUTHER
ADRFED W. WOODS
ALFRED S. JOHNSON, M. A., PH. D. } *Associate Editors*

BUSINESS DEPARTMENT

WM. A. RADFORD, *President and Treasurer*
H. M. RADFORD, *Secretary*
E. L. HATFIELD, *General Manager*

New York Office: 178 Fulton Street
E. B. WOLFROM, *Eastern Representative*

SUBSCRIPTION RATES

One Year, \$2.00; six months, \$1.00; payable always in advance. Single Copies, 20 cents. Canadian Subscriptions, \$2.50. Foreign Subscriptions, \$3.00.

ADVERTISING RATES

Furnished on application. Advertisements, to insure insertion should reach our Chicago office not later than the 20th of the month preceding date of publication.

PROTECTION FOR OUR READERS

The publishers of the American Carpenter and Builder will not knowingly publish any advertisement of a misleading character nor accept advertising from any individual, firm or company whose business methods are open to question.

We often receive inquiries from readers who desire information about concerns that formerly used the advertising pages of the American Carpenter and Builder, but are no longer doing so. They want to know if these former advertisers are still in business, if they can send them orders with the assurance that they will be filled, and a variety of other questions.

The American Carpenter and Builder will use every legitimate means to safeguard the interests of its readers and to protect them from fraudulent or unreliable concerns. Where the slightest doubt exists our readers should write the publishers for information. It may save them money, time and worry.

In all cases in writing to advertisers say: "I saw your advertisement in the American Carpenter and Builder."

VOL. XVI.

FEBRUARY, 1914.

No. 5

Bigger Building Business Predicted

CONFIDENTIAL REPORTS SHOW THAT "OUR FOLKS" DID OVER 742 MILLION DOLLARS WORTH OF BUILDING WORK LAST YEAR, AND THAT THE MAJORITY HAVE IN SIGHT STILL GREATER BUSINESS FOR 1914

THE year just ended has been a very satisfactory one in the building field, but 1914 is to be much better, according to confidential reports from representative contractors and builders in every section of the United States and Canada, collected by the AMERICAN CARPENTER AND BUILDER in the recent investigation or census of subscribers. Great optimism prevails among builders in practically every part of the country. Throughout New York, Pennsylvania, the upper Mississippi Valley, and the Pacific Coast states the outlook is especially bright.

In all of the North Central states without exception, builders expect better business. In the North Atlantic states—New York, New Jersey, Pennsylvania, and Vermont, builders predict an increase; while in Maine, Massachusetts, New Hampshire and Rhode Island normal conditions are expected. Connecticut builders are dubious or too conservative to say one way or another.

In the South Atlantic states—Florida, Maryland, North Carolina, and West Virginia—builders predict

an increase. Construction work in Virginia will average about the same. A decrease is expected in Delaware, while in Georgia and South Carolina present prospects do not warrant any prediction as to the future. Reports from the South Central states are encouraging. Alabama, Kentucky, Louisiana, Mississippi, Oklahoma, and Tennessee, look forward to substantial gains over last year. Arkansas will have normal business.

The Western states are very optimistic; all except Washington, New Mexico, and Nevada report much better prospects. The Canadians also are confident of the future, the majority of reports from every province predicting an increase in 1914 over last year.

It seems entirely reasonable that the local contractor and builder has his work for the coming year pretty well gauged by this time. Thus, after making all allowances for overconfidence and enthusiasm, these reports augur well for a busy building season this year.

The Forecast by States is on Next Page

Forecast of 1914 Building Business

As reported by representative contractors and builders in every section of the United States and Canada, to the publishers of the AMERICAN CARPENTER AND BUILDER (Chicago) in their recent investigation or census of their 40,000 subscribers.

How will 1914 compare with last year?	Percentage of Reports from each state predicting			
	Bet-ter	Same	Worse	Non-Com-mittal
	Per Cent	Per Cent	Per Cent	Per Cent
Northern Central States				
Illinois.....Improvement	45	27	10	18
Indiana.....Better	45	35	10	10
Iowa.....Considerably better	40	42	5	13
Kansas.....Improvement	25	59	16	..
Michigan.....Better	41	27	13	19
Minnesota.....Much better	50	50
Missouri.....Much better	51	42	5	2
Nebraska.....Favorable	38	38	7	17
North Dakota...Much better	62	25	..	13
Ohio.....Improvement	35	46	1	12
South Dakota...Better	58	14	14	14
Wisconsin.....Improvement	34	32	12	12
North Atlantic States				
Connecticut....Non-committal	100
Maine.....About the same	25	50	25	..
Massachusetts...Normal	12	44	12	32
New Hampshire..Equal	100
New Jersey.....Better	50	25	25	..
New York.....Improvement	39	38	10	13
Pennsylvania...Improvement	31	26	9	34
Rhode Island...Same	100
Vermont.....Better	100
South Atlantic States				
Delaware.....Not as good	100	..
Florida.....Better	50	50
Georgia.....Non-committal	100
Maryland.....Much better	100
North Carolina..Better	50	25	25	..
South Carolina..Non-committal	100
Virginia.....Average same	50	..	50	..
West Virginia...Improvement	50	34	..	16
Southern Central States				
Alabama.....Slightly better	33	67
Arkansas.....Probably equal	100
Kentucky.....Slightly better	37	37	..	26
Louisiana.....Much better	100
Mississippi.....Favorable	100
Oklahoma.....Better	50	25	..	25
Tennessee.....Much better	100
Western States				
Arizona.....Improvement	100
California.....Much better	54	30	14	2
Colorado.....Better	60	40
Idaho.....Much better	75	25
Montana.....Optimistic	100
Nevada.....Non-committal	100
New Mexico....Same	50	..	50
Oregon.....Far better	66	17	17	..
Texas.....Better	65	35
Utah.....Far better	100
Washington....Not so well	25	25	50	..
Wyoming.....Better	100
Canada				
Alberta.....Improvement	50	50
Brit. Columbia..Better	50	..	25	25
Manitoba.....Much better	100
New Brunswick..Better	100
Ontario.....Better	53	37	..	10
Saskatchewan...Optimistic	100
Quebec.....Better	100

Other Interesting Facts Brought Out by Census

With the purpose of being able thereby to serve its readers better, the AMERICAN CARPENTER AND BUILDER has just completed the most thorough and far-reaching investigation or census of its subscribers ever undertaken by any class publication. It has absolute data giving in detail the occupations of its readers, the class of work they do, the number of contracts they handled during 1913, and the value of these contracts, the equipment they own and what it consists of, and what additional equipment they are now in the market for.

This investigation has covered every state in the Union and province of Canada. Briefly summarized, these census reports show that AMERICAN CARPENTER AND BUILDER readers are engaged in every branch of the building industry. The carpenter and builder is in many instances his own architect, specifying or recommending all building and finishing materials—he has charge also of the plumbing, heating, painting and decorating, metal and cement work.

It is interesting to note that 64.9 per cent of our readers act as architect as well as builder, and our investigation shows that every reader averaged 7.5 building contracts during 1913.

It is evident that the typical AMERICAN CARPENTER AND BUILDER reader is a versatile man, equipped to accept and handle every sort of building work that presents itself in his locality. He is the responsible man to whom the building owners turn for expert advice and service on all building work.

Number and Value of Contracts Handled Last Year

From the Confidential Census reports furnished us by our readers, we learn many interesting facts, especially as to the volume of work handled by them. The following figures are based upon these reports which have been received from every section of the United States, and figuring the same percentage for our total circulation of 40,000:

Number of contracts handled in 1913.....	300,000
Average for each reader.....	7.5
Value of contracts handled in 1913.....	\$742,036,400.00
Average amount of each contract.....	\$2,473.45
Average year's business for each reader.....	\$18,550.91

We wish to emphasize the fact that this average, \$18,550.91, represents the average year's business for every one of our readers, big and little. It is not the average for the building contractors only. Even the apprentice boys have been figured in, and the average for all is this amount.

Strong for Power Equipment

8.4 per cent of our subscribers, totalling 3,360, state that they own concrete or mortar mixers.

5.3 per cent or 2,120, are now in the market, they inform us, for concrete mixers, or mortar mixers.

18.8 per cent of our subscribers, or 7,520, inform us that they own power woodworking machinery.

14.6 per cent, or 5,840, state that they are at the present time considering buying shop woodworkers.

Besides these, 8.7 per cent, or 3,480, are in the market for portable power woodworkers, and 11.5 per cent, or a total of 4,600, state that they have already purchased and are operating portable woodworkers.

4.7 per cent of AMERICAN CARPENTER AND BUILDER subscribers, totalling 1,880, own power hoists. As a man has to be doing quite a good sized contracting business to need power-hoisting apparatus, these figures speak well for the work being done by this part of our readers.

Most of the equipment mentioned above is gasoline engine driven. In addition to these, 5.3 per cent of our subscribers, or 2,120, inform us that they are now considering purchasing gas engines. 600 are in the market for electric motors.

A total of 36 per cent—14,400 AMERICAN CARPENTER AND BUILDER subscribers, state that they are at this time considering investing in some item of power equipment.

Contractors and "A. C. & B." Advertising

A careful study of the census reports demonstrates the very high regard in which the AMERICAN CARPENTER AND BUILDER and especially its advertising pages, are held by contractors, builders, carpenters and architects. 94.5 per cent, or 37,800, of our readers state that they study the advertising pages of the AMERICAN CARPENTER AND BUILDER. Readers operating in 59.6 per cent of the towns into which the magazine goes, inform us that their local dealers do not carry everything they need as up-to-date builders.

For this reason our readers find the advertising pages of the AMERICAN CARPENTER AND BUILDER their handiest and most reliable guide in purchasing and investigating building and finishing materials, and building equipment; also tools and builders' gear of all kinds.

The high regard in which the AMERICAN CARPENTER AND BUILDER is held by its readers is strikingly testified to by the fact that 93 per cent of our subscribers state that they preserve their copies of the magazine, filing them carefully away for future reference. 35.1 per cent, or a total of 14,040, subscribers have even gone to the trouble and expense of having their copies of the AMERICAN CARPENTER AND BUILDER bound.

✦ Teach Your Boys to Make Things

CARPENTERS and Builders, teach your boys to make things. Whether they will follow your trade when they grow up or not, let them, while they are still boys, give expression to that "making instinct" which is so sure to be in nearly every lad. And since our boys must create something, we should see to it that they create something useful.

There lies the great advantage of a carpenter's life: it is spent in making the fundamentals of man's material existence. We may get along without poets and artists, but we cannot get along without carpenters and builders. You therefore have it in your power

to teach your sons how to make the very best there is to make in the world. And children always want to feel that what they do has the dignity of usefulness.

If you have a barn on your place, partition off a little part of it, as much as you feel you can spare, and give it to your boy for a tool shop. Let him know that it is all his own, as respected and undisturbed as your own work place. Show him how to build a carpenter's bench, how to fasten a vise to it, and then see that he gets as many tools as he needs for constructing simple, useful things. Any boy will love such a chance to exercise his ingenuity, and will not abuse his opportunity.

When he has made his table or bookcase or footstool or whatever it may be, and brings it to you for



Give Your Boy Honest Criticism

inspection, give it the honest criticism you would accord a work of a brother carpenter. It will, of course, be crooked and uneven and rude, but if it is an honest attempt, it deserves neither contempt nor indifference and may be the beginnings of a skilled workman. Your boy should know that you will respect the things he makes, even though they prove too crude for use in the house, and will show him where a nail has been hit on the head and where it has missed aim. He is very sure that you know everything, and a word of help and praise from you is a golden reward.

If you have no barn to give him part of, perhaps there is an unused room in your cellar or even a corner of it, that could be partitioned off for a tool shop. The cellar of most houses is warm and comfortable because of the presence of the furnace, and the long winter evenings are just the times when boys like to tinker and saw. The cellar is an excellent place for a tool shop, and the enjoyment and education that your son will get from this sort of amateur carpentering will richly repay you for whatever sacrifice you may have to make to give him the room.—LORRAINE A. ALLEN, West Newton, Mass.



Found His El Dorado in Denver

PAY-DIRT IN HIS OWN TRADE

By James A. Patterson

DURING the winter of 1898-99, E. P. Robinson, a Greeley carpenter, did not find steady work in his home town. In his leisure he spent much time reading newspaper stories; especially items relating to the discovery of gold in the Klondyke. To these highly-colored reports he at first paid little attention; but as the winter dragged out its weary length, and conditions in the building line did not indicate great activity in building for the coming summer, he became more infused with the glowing prospects in the far North. Toward spring he was thoroughly inoculated with the gold-fever germ.

In March, 1899, he packed up a few tools and started for San Francisco, where he in company with nine other venturesome spirits chartered a sailing vessel (Hattie Melton). The company pooled their capital, loaded the vessel with mining outfits, a year's supply of food, and a small side-wheel steamer (knock-down) to be used for transportation on the Yukon and its tributaries; started for St. Michael's, where they landed after forty days' sail.

Prospecting on the Koyukuk and the Yukokakat; the mishaps met, the privations endured—fighting against man and beast, the rigors of an Arctic climate would make a story too long for this article. Suffice it to say, two years spent in the chase after elusive fortune had brought no tangible results. Flour-gold, obtained by placer-mining, was the only find that had yielded a paltry pittance, wholly out of proportion to the time and labor involved in washing.

Supplies had long since been exhausted, and exorbitant prices were now paid for plain food. Three of the original company had died; four others had become discouraged and returned to "God's Country." The prolonged struggle, strain of disappointment, lack of well-balanced diet, were slowly but surely destroying nerve tone; an intense, harried expression was evident around the eyes of all the remaining members.



In June, 1901, Robinson took a mental inventory, summed up in these words: "Digging and delving from morning till night, no comforts, half enough to eat, nothing in sight; the game is not worth the candle, back to civilization and three square meals a day."

Robinson arrived in Denver, August 10, found work at his trade, reconciled to the fact that moderate wages with ordinary comforts of life were to be preferred to the most alluring prospects of finding wealth in the Klondyke. The first winter after his return from the North he took a three-months' course in mechanical drawing, which has since enabled him to do his own drafting. Working by the day as a starter, he gradually enlarged his plans until he secured a shop, began taking contracts for building and engaged other men to assist him as required. During the summer



The Game is not Worth the Candle—Back to Civilization

of 1913 he had contracts which kept himself and four other men employed until Christmas, the last job being on a row of five modern stores erected at 6th and Gilpin streets. When new outside work is not feasible on account of severe winter weather, he is kept busy repairing a string of houses handled by a realty company as renting agents.

His shop is a model of neatness, equipment and system. A desk fitted with drawers, all properly labeled for important papers; extension table for use in drafting. Next to the desk stands a large wall cabinet (his own make) equipped



with drawers, hooks, and shelves of various sizes for holding small supplies; several other time-saving devices enable him to lay his hand immediately upon the article wanted. For sharpening tools an electric motor is connected with a grindstone.

If Robinson uses a motto, I should say it was: "Avoid Puttering." When there is work on hand, he sets about doing it with a decisive promptness that stands out in marked contrast to the dilly-dally methods of some men. A certain man for whom he built a cottage, when asked why he gave the contract to Robinson in preference to another man whose bid was lower, replied: "If Robinson promises to finish the job on July 1, I know he will hand me the key on June 30."

For 1914 he has already secured enough contracts for new suburban buildings to keep himself and three other men employed from April to September.

Second Edition Now Being Bound

WE are sorry to have kept a number of our readers waiting for their copies of "Radford's Estimating and Contracting." Enlarged to a 900-page book, leather bound, the demand for it has upset all our expectations. The 1st Edition of 15,000 copies is completely sold out and the 2nd Edition is not yet quite ready. But our printers and binders are hard at work; and we will be able to fill orders again in a few days.



Good Work Exhibited at New York Trade School

On January 20th, the Baron de Hirsch Trade School, East 64th St., held an exhibition of pupils' work. Many visitors were present. The exhibits all testified to the soundness and thoroughgoing nature of the trade instruction afforded the pupils of this school.

Interest in Metal Lath is Shown

DECEMBER AD. PUZZLE PRIZE CONTEST BRINGS TO LIGHT MANY NEW AND IMPORTANT USES TO WHICH METAL LATH IS BEING PUT BY CARPENTERS AND BUILDERS

ONE of the most popular of our popular advertising puzzles was the one in the December issue where our readers were asked to write on the subject, "Metal Lath—Why I am Interested in It and How I Use It."

The majority apparently had a great fund of experience in the use of this material to draw upon.

Others living in parts of the country where metal lath is little known as yet, took the opportunity to study up the matter, writing to our advertisers for samples, hand books, catalogs, etc.

Thus, the contest proved educational as well as good fun, and that is what we wanted. Readers have been entertained and benefited by it.

The Prize Winners in the December Ad. Puzzle Contest are the Following:

First prize, \$10.00 worth of goods selected from our ad. pages:

C. C. SEIFERT, Contractor and Builder, Rolfe, Iowa.

Two second prizes, consisting of \$5.00 worth of goods selected from our ad. pages:

FRANK M. KERR, Carpenter and Builder, Normal, Ill. and

H. P. GERBER, Instructor in Carpentry, The Northern Normal and Industrial School, Aberdeen, S. D.

Ten third prizes, each consisting of \$1.00 worth of goods selected from our ad. pages:

THOS. L. HICKEY, of L. A. Hickey's Sons, General Contractors and Builders, South Bend, Ind.

GEORGE K. HALL, Contractor and Builder, East New Market, Md.

GEORGE W. PAYNE, Architect, Carthage, Ill.

FRED DAVENPORT, Marcelene, Mo.

WM. LOESCH, Contractor and Builder, Pasadena, Calif.

RUDOLPH W. FESCH, Brick and Plaster Contractor, Keokuk, Ill.

L. W. HOLLISTER, of Hollister, Amos & Co., Retail Lumber Dealers, Oshkosh, Wis.

HARRISON WEBER, Carpenter, Contractor and Builder, Norristown, Pa.

CARLOS G. JOHNSON, Contractor and Builder, Lincoln, Neb.

ERNEST A. MILLER, Detroit, Mich.

This Month, "Importance of Good Appearance" Contest

ON the next page we have a puzzle consisting of clippings from twenty-three advertisements in this issue of the AMERICAN CARPENTER AND BUILDER. You will find it good sport and at the same time worth any busy man's time to study over all of our advertising pages this month, noting the new improvements that are announced; new catalogs ready for distribution; and free samples that advertisers will send our readers who are interested. After reading the advertisements you will find it easy to identify the clippings in the puzzle.

For the subject to be written about this time we have chosen what every business man recognizes as

highly important—the appearance of letters, statements, estimates, and other written matter which every carpenter and builder has to send out. Write a letter of not less than 100 words on this subject: "Why a Carpenter and Builder Should Use Business Stationery and Own a Typewriter." Every one has at some time or other had an experience that will throw some light on this subject.

NOTICE—Mistake in January Puzzle

In last month's puzzle, clipping No. 21 is from the Milwaukee Corrugating Co.'s ad. in the December number. All clippings should have been from the current issue. This one got in by mistake.

More Fun and Prizes For All Who Read Our Advertising Pages

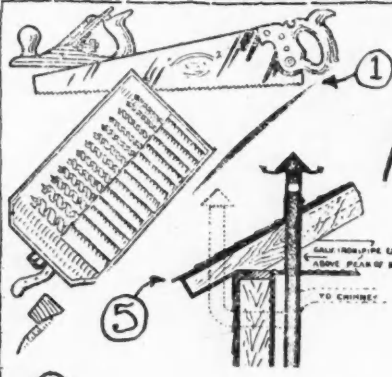

ORIGINAL MAKERS of Flexible Asphalt

A Better Builder

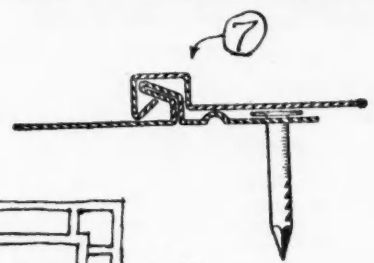

Durametal

Owning a Broncho Mixer gives a man prestige and

February Ad. Puzzle Prize Contest

Here are fragments of 23 advertisements appearing in this issue. Can you identify them? Some are old friends; some you will have to hunt a little to locate. Study our advertising pages this month; read every offer. Then list the 23 ads, these were clipped from. Be sure to give the names and addresses and the page numbers. Also write a brief, straightforward letter of not less than 100 words, on this subject:

"Why a Carpenter and Builder Should Use Business Stationery and Own a Typewriter."

We Will Award These Prizes 13 Prizes—\$30 in Prizes

- For the best letter (and correct Puzzle solution) \$10.00 worth of goods selected from our Ad. pages.
- For the 2 next best letters (and correct Puzzle solution) \$5.00 worth of goods selected from our Ad. pages.
- For the 10 next best letters (and correct Puzzle solution) \$1.00 worth of goods selected from our Ad. pages.

When sending in your Puzzle answer and Letter, be sure to state the goods you select from our Ad. Pages, in case you win a prize; goods of ANY value may be selected, and prizes will apply either in whole or part payment of them.

This Contest Closes MONDAY, March 16th.
Prize winners will be announced in April issue.

Address your letters to your friend, THE ADVERTISING EDITOR, "American Carpenter and Builder," Chicago.



LITTLE WONDER "FIVE" WITH SIDE LOADER



Ask for our "Modern Wood Finishing"—a beautifully illus-

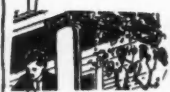

Pays

Largest Direct Installers

—they form the foundation for a money making shop and mill equipment.

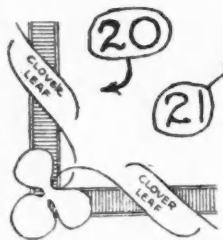

Don't give your equipment heart failure!

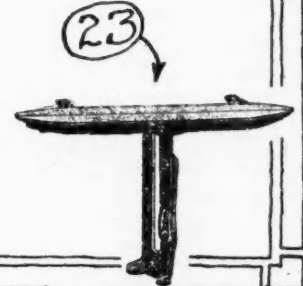
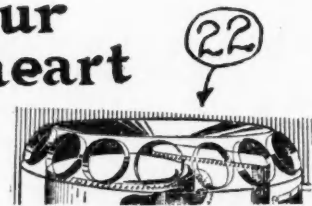

e Best price

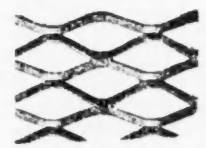

US

The Builders' Alphabet—(Continued)

Verses by A. D. Hunter, Drawings by P. J. K.



M stands for Mixer: concrete or good;
To own one and be one each contractor should.
If you're a good mixer and own one or two,
You can bid competition one fond last adieu.*



N stands for New Things you builders must know,
If you want to see your own business grow.
These new things are vital; your clients demand 'em;
Old fashioned methods?—They long since have canned 'em.



O stands for Obstacles, all builders meet;
You must surmount them; if not, then you're beat.
The whole world admires and looks up to a winner,
But the man who's defeated—no pie with his dinner!



P stands for Pay-Day, weekly enjoyment
To the man who's alive and has steady employment.
Of course, if you're boss, and you pay the boys,
Pay-days are not always days of great joys.

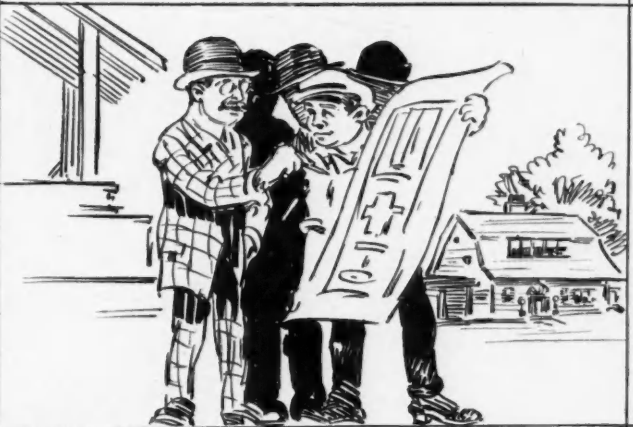

Q stands for Questions that arise every minute
In the course of construction. That man's strictly in it
Who can answer these questions, or figure them right.
If he can't, he's a loser; fat contract, GOOD NIGHT!

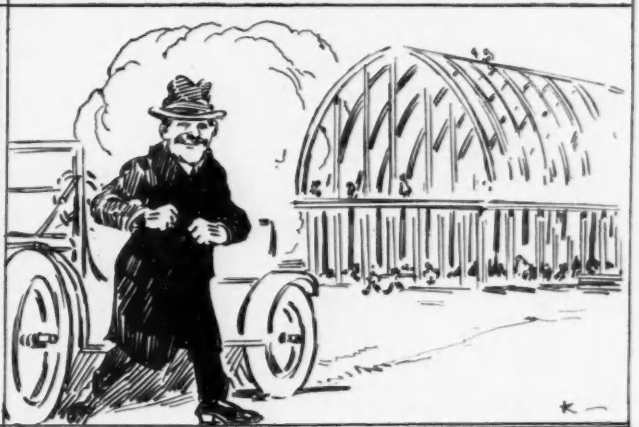

R stands for Rafter, a poor workman's nightmare;
To the man who knows "framing" it's only a light care.
But if he makes "steel square" and "framing" his motto
He'll soon have no boss, but will drive his own auto.

*French for kiss 'em good-bye.

Concluded Next Month; Watch for the Big Windup!

3 Sq. Miles of Building Under Way for Panama-Pacific Fair

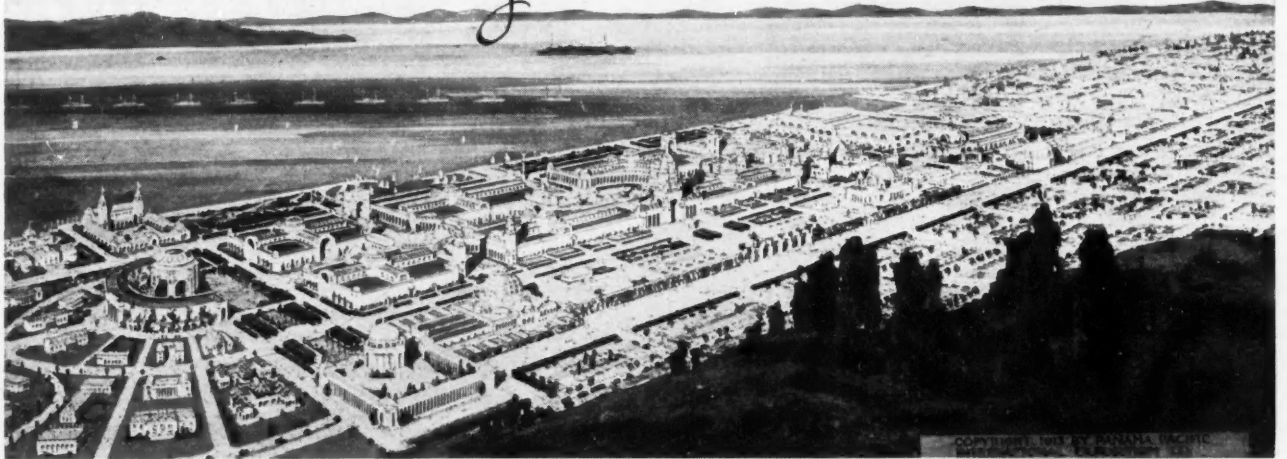

Panorama of the site, on San Francisco Bay, of the Panama-Pacific International Exposition to be held in San Francisco in 1915, to celebrate the opening of the Panama Canal. The buildings face north upon the harbor for almost three miles and are located just inside the famous Golden Gate entrance of the harbor to the Pacific Ocean.

ORIENTAL eyes casting to eastward and those of the Occident turned further to the west are converging upon a common horizon—the Panama-Pacific Exposition site at San Francisco, where a congress of nations will flaunt their banners in 1915. Thousands of busy men are whipping into shape the largest World's Fair—the most artistic demonstration of civilization's progress since creation.

The wonder of it is the precision with which this gigantic task is being pushed to completion. The

huge shell will be ready to receive the exhibits months before this great exposition commemorating the completion of the Panama Canal opens its gates on February 20, 1915.

Six hundred and thirty-five acres have been set aside for the physical equipment of the exposition. The grounds are ample, the scenic setting unsurpassed in beauty, and the architectural plan the highest conception of the best of the world's artists. In the center of the picture eight great exhibit palaces are grouped together in a parallelogram, separated only

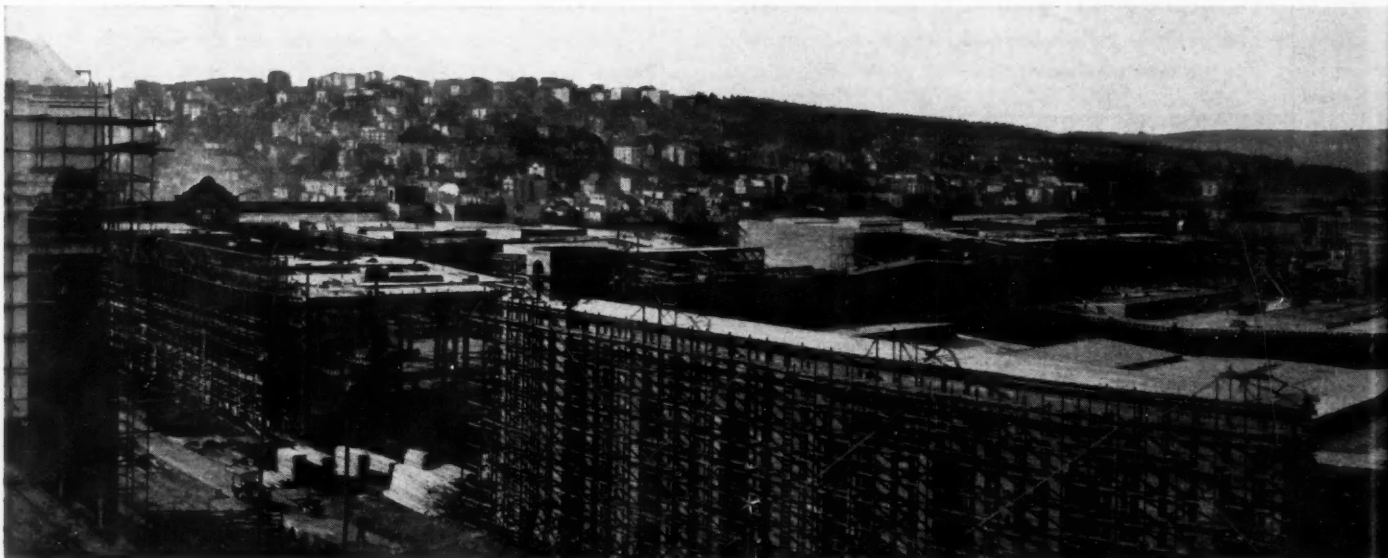

This photograph was taken from the roof of the Palace of Machinery on December 3, 1913, and shows a part of the main building complex. The large building with the dome, in the center of the photograph, is the Palace of Education and Social Economics. The large building with the dome, in the center of the photograph, where is seen a pool of water, is the location of one of the exhibit palaces, and many thousand men are at work. When completed, a number of the towers, domes and spires will be visible from the city. This photograph shows the outside walls of some of the buildings, and also reveals the spaces over which towers are being built in Chicago, and also reveals the spaces over which towers

by connecting avenues and ornamental courts. These palaces are devoted respectively to Varied Industries, Manufactures, Liberal Arts, Education and Social Economy, Food Products, Agriculture, Transportation, and Mines and Metallurgy. To the east of the parallelogram is placed the magnificent Machinery Hall, to the west the Palace of Fine Arts, while to the south, surrounded by the extensive horticultural gardens, stand Festival Hall and the Palace of Horticulture. Stretching from Machinery Hall eastward to Van Ness Avenue of the city are the amusement concessions containing sixty-five acres, while to the west, spreading fan shaped along the bay, are the sections devoted to the pavilions of the states and foreign nations, while yet beyond these, a part of the famous military reservation, the Presidio, are the stock yards and barns in which will be shown the greatest collection of domestic animals ever assembled, and the aviation field, race track, and drill grounds, in which ten thousand troops may be maneuvered at the same time. In front of the main group of exhibit palaces, along the bay, runs the Esplanade, ornamented with shrubs and plants from two climes; and in the bay itself may ride at anchor the fleets of all nations, overlooking the scene, with the Golden Gate in the distance.

This plan is the result of careful consideration on the part of the Board of Directors with the assistance of world renowned architects, and has two objects, the convenience of the visitors, and a unique architectural scheme, unlike that of any other exposition, highly adaptable to the scenic setting and admitting of a color treatment in harmony with the California sea, sky and shore. This grouping together of buildings modifies the architecture of their facades,



Horticultural Building, which will be 630 by 295 feet—one of the most notable structures of the kind ever built, being composed almost entirely of glass; set in the west end of the south garden opposite the Palace of Education, its glittering dome, 165 feet high, will be seen as one of the striking features of the exposition.

constituting these at the same time the walls of the courts, which are adorned with colonnades, magnificent arches, lofty towers and symbolic statuary. At the main entrance, on the east side, rises to a height of more than 400 feet, a great tower called the Tower of Jewels, a noble and impressive structure, the dominating feature of the plan; while on the bay side, in front of the main entrance, a single shaft, representing the rise of mankind, is called the Column of Progress. The three main courts are ranged along the east and west axis of the central group of palaces, in the center of the Court of the Sun and Stars, so named because of the idea of space which it engenders, a court surrounded with colonnades, above which are ranged one hundred and ten star-crowned figures, capable in extent of containing a sunken garden seating seven thousand persons; to the east of this, the Court of Abundance, devoted to festivals;

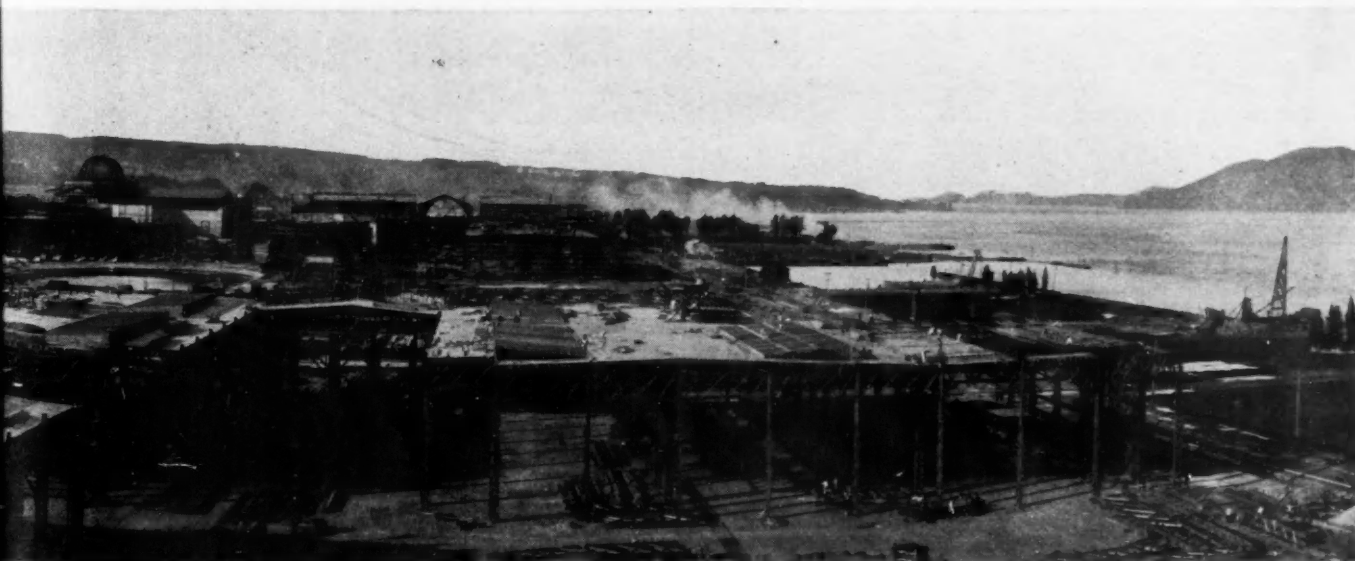

of the main exhibit section of the Panama-Pacific International Exposition. At the extreme left is shown a portion of the Palace of Varied Industries and Social Economy. To the right are to be seen the Palaces of Transportation, Agriculture and Food Products. This dome is 165 feet above the ground. To the left of the Palace of Education is the Palace of Liberal Arts. At the inner courts of the exposition. More than 80,000,000 feet of lumber are being used in this section. Higher gateways will rise higher than the first rim of hills seen to the right, the Tower of Jewels. The domes and towers, which are identical in height with those of the World's Columbian Exposition. The domes and huge vaulted arcades will be erected.

and to the west the Court of the Four Seasons, devoted to a representation of the opulence of Nature. The palaces themselves have the appearance of Travertine marble, relieved by the vivid coloring of the ornamentation, the whole forming a picture of inspiring splendor and beauty. North and south, from the Tower of Jewels to the Column of Progress, runs an avenue, which divides the compact group of palaces into two parts, and by the ornamentation of the eastern and western divisions thus created, the Orient and Occident are exemplified, suggesting the idea of the work of the Panama Canal—that here, on this western shore of the continents, the East and West are at last united, and that by the commerce thus aroused and amplified, there shall ensue a greater peace for the nations and a higher progress for mankind.

Construction is proceeding with prodigious rapidity. All of the eleven main exhibit palaces are under construction. The work ranges in degree of completion from the Palace of Fine Arts, for which the piling is in place and the steel being fabricated in the East; and the Palace of Transportation of which the floor is laid, and the frames being assembled preparatory to erection, to the Palace of Machinery, nearly fin-

ished. The Palace of Education is 67 per cent completed, its domes being placed, and the outer walls receiving their staff work. The completion of this palace will follow closely that of the Palace of Machinery which is now 93 per cent completed.

A striking example of the rapidity of construction is furnished in the case of the Palace of Food Products. In a single month 900,000 feet of material were put in the superstructure of this building, with the result that the frame was approximately 80 per cent in place in that period, the entire structure being 45 per cent completed. The immensity of this work may be realized from the fact that the Palace of Food Products covers an area of more than five acres, and is 96 feet high to top of ridge and 160 feet high to top of dome above the floor.

Work is progressing on the five great interior courts of the main group of exhibit palaces. The fire-proof walls of the courts are being built rapidly, the walls of the Court of the Four Seasons being practically completed.

Many of the most important and heaviest tasks in the preparation of the exposition have been completed. Such are the installation of the water, drainage, and electric conduit systems; the construction



The Palace of Food Products, one of the main exhibit palaces of the Panama-Pacific International Exposition, as it now appears. 45 per cent completed. Upon that date, 900,000 feet of material had been placed and used in the construction. Compared with the already completed Palace of Machinery, the largest wooden building the world has ever employed to ensure the finishing of the exposition on time. The Palace of Food Products covers ground to the top of the dome

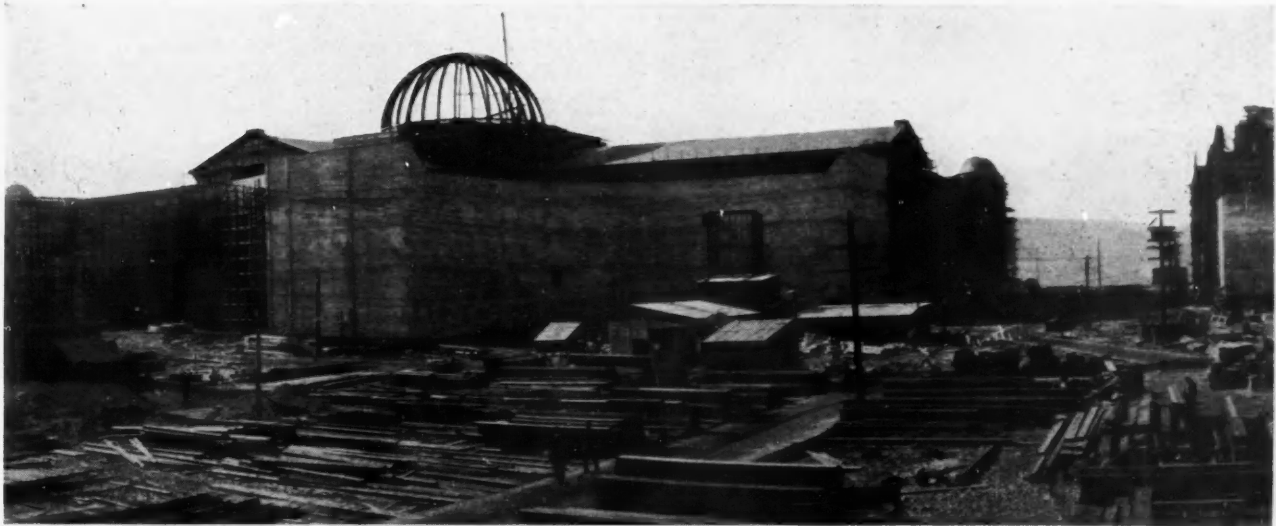

The Court of the Four Seasons as it Appears in the Making.

This photograph shows a part of the huge Court of the Four Seasons. The building on the left is the Palace of Education, while that on the right is Agriculture. The avenue between the buildings extends east and west and the picture is taken looking west toward the Golden Gate.

of seawalls, wharves and freight ferry slip, of the standard gauge terminal railroad system and other necessities.

The freight ferry slip is now in daily use, receiving car floats bearing cars, which are conveyed by the exposition engines over the terminal railroad track,



The work of constructing this immense building was commenced October 1, 1913, and thirty days afterward it was more than half taking shape, the Palace of Food Products will soon present to the eye its marvelous beauty and may be completed. The main group of buildings is being rushed toward completion, thousands of workmen are employed on an area of more than five acres and will rise 96 feet high to the ridge of the roof and from the center will be 160 feet in height.

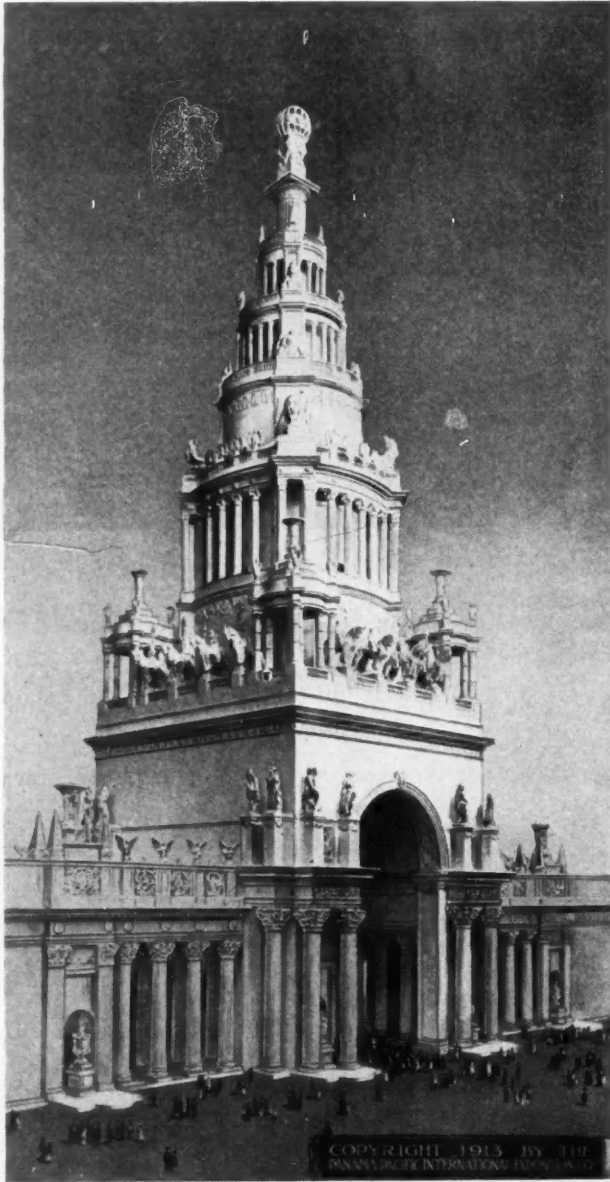

A Marvelous Setting for Sculpture.

The dominating architectural feature of the exposition, the superb tower gateway, which will command the south entrance of the Court of Sun and Stars. This tower, 430 feet in height, will have a base one acre in extent. The tower will rise upward, in terraces, giving way at last to a group of figures supporting a globe, typifying the world. The repeated figures of armored horsemen and of explorers of the oceans will be used on the tower which, with its statuary, mural paintings and mosaics, will be indescribably beautiful. Carrere and Hastings are the architects.

the main line of which, and many of the branches, have been completed.

The landscape engineering is progressing rapidly. The exposition site, which, a few months ago, was a waste of sand dunes, rubbish and gravel, now shows many acres of greensward, the grass growing luxuriantly in the south and north gardens, in the concessions district and elsewhere.

The transplanting of trees and shrubs from the nurseries is progressing, the groves of cypress and other trees are to be seen upon the grounds contrib-

uting to the final park-like appearance that will characterize the exposition long before 1915.

In the sculptural warehouses fifty sculptors and skilled artisans are at work. Under the direction of A. Stirling Calder the plaster models made by many of America's greatest sculptors are being enlarged to heroic proportions, finished in imitation Travertine marble, and prepared for installation upon their pedestals.

Three fire houses for the exposition fire department are nearly finished. One is in the concessions district, one adjoins the Service Building and one between the Palace of Fine Arts and the California Building. Temporary fire equipment has already been installed.

It has been estimated that \$80,000,000 will be expended at the Panama-Pacific International Exposition exclusive of the vast wealth represented in the exhibits of the world.

As the visions of many of America's greatest architects, sculptors, and artists become realities; as the magnitude of the exposition design is today revealed by prodigious progress in construction, the world sees come true every great ideal which was cherished for this vast and complex undertaking.

✦
Keep up the Good Work, Boys

*"Good, better, best,
Never let it rest,
Till the best is better,
And the better, best."*

THIS appears in the first issue of *The Young Apprentice*, the Apprentice School paper, New Haven, Conn. If the boys will take it as their motto they will go far and find success sitting in the middle of the road waiting for them.

✦
The Largest Steel Gear

A steel gear wheel, that is unusual and probably the largest ever manufactured, was shipped recently to the Inland Steel Co. of Chicago, and will be used for driving their sheet mill. This gear is 22 feet 8 inches in diameter. The face is 38 inches wide. There are 154 teeth in the gear, and they are set staggered in three sections. When in operation, these gears will travel at a speed of 2,000 feet per minute. Made by the Mesta Machine Co.



Man is a Pigmy Beside This Huge Steel Gear Wheel

COLONIAL PORCH DETAILS

No style is more popular today for the best work than the Colonial. The old motifs are used with very often a refreshing addition of the new, — as the bungalow rafters on this Colonial porch. For a small front entrance or where the main entrance is on the side, this detail is admirable. The measured drawings are to a scale of $\frac{3}{8}$ inch equals one foot.

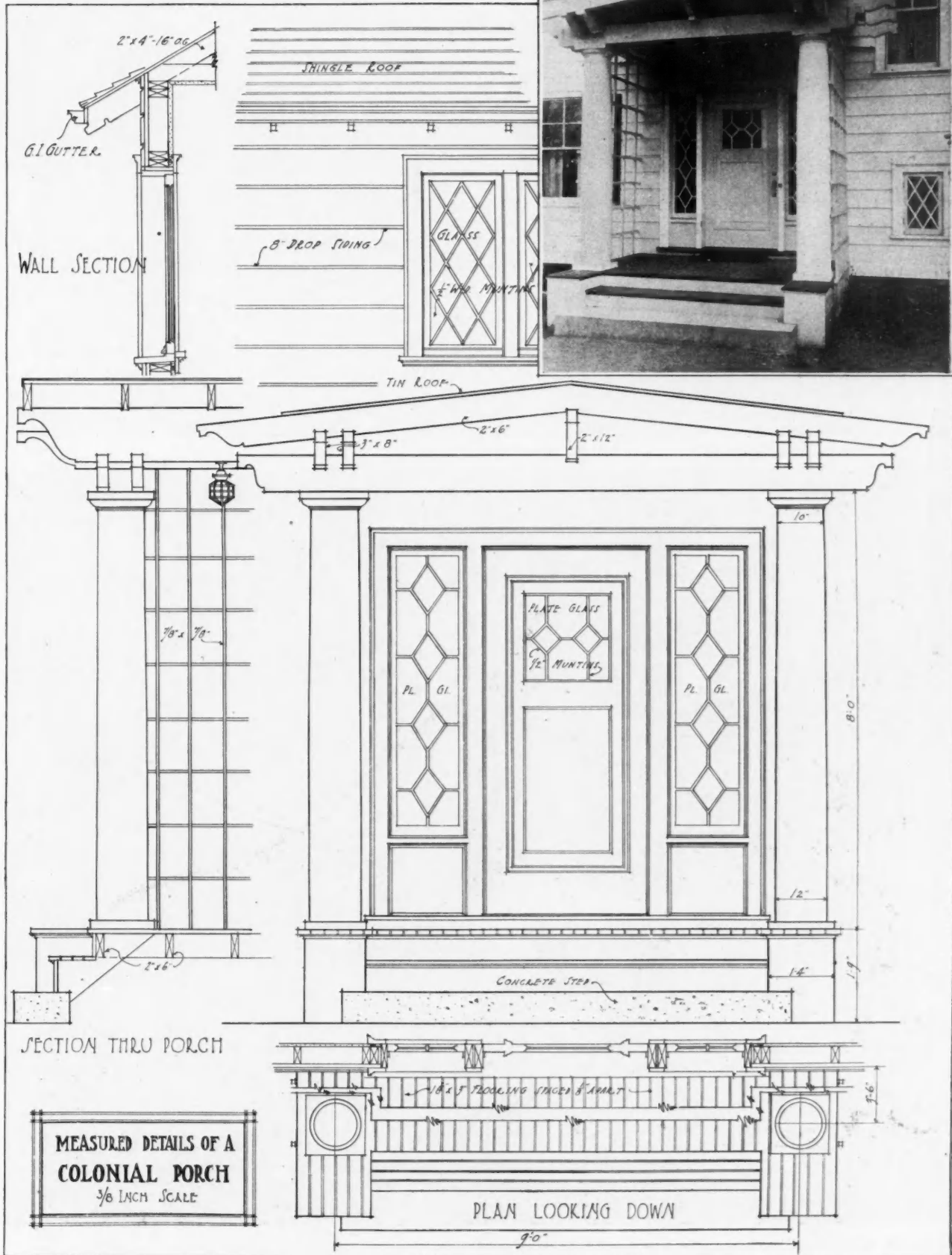
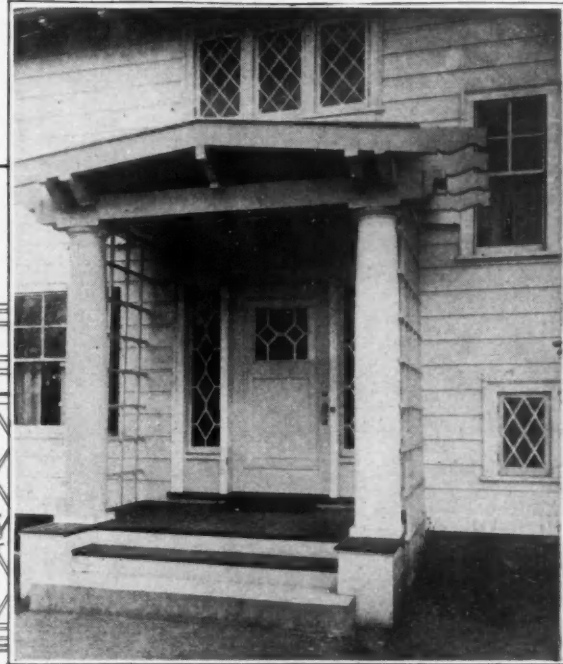

MEASURED DETAILS OF A
COLONIAL PORCH
 $\frac{3}{8}$ INCH SCALE

PLAN LOOKING DOWN



Model Home Designs



Ceiling Beams Popular with Home Builders

ALMOST every one wants ceiling beams these days. For the living room and the dining room and the library or den, ceiling beams give a rich ornamental effect. They carry an atmosphere of coziness and warmth.

Our ancestors long ago built their houses out of heavy hewn timbers; and

in those days ceiling beams were *real*. To-day we use the beams only for their ornamental effect. They carry no load, but are merely shells of wood, hollow inside.

A real old-fashioned beam ceiling would cost a fortune these days, and wouldn't be as attractive to most as

the modern ornamental beams or panel work, which cost relatively little. The old structural beams could be arranged in only one way—as in the photograph; but we nail them up now in any number of unique and artistic ways—to work in with electric lighting schemes and for other decoration.



Remodelled interior of old New England homestead, showing genuine heavy oak ceiling beams. These carry the weight of the floor above. Modern beams are tacked on for ornamental effect. They carry no weight.

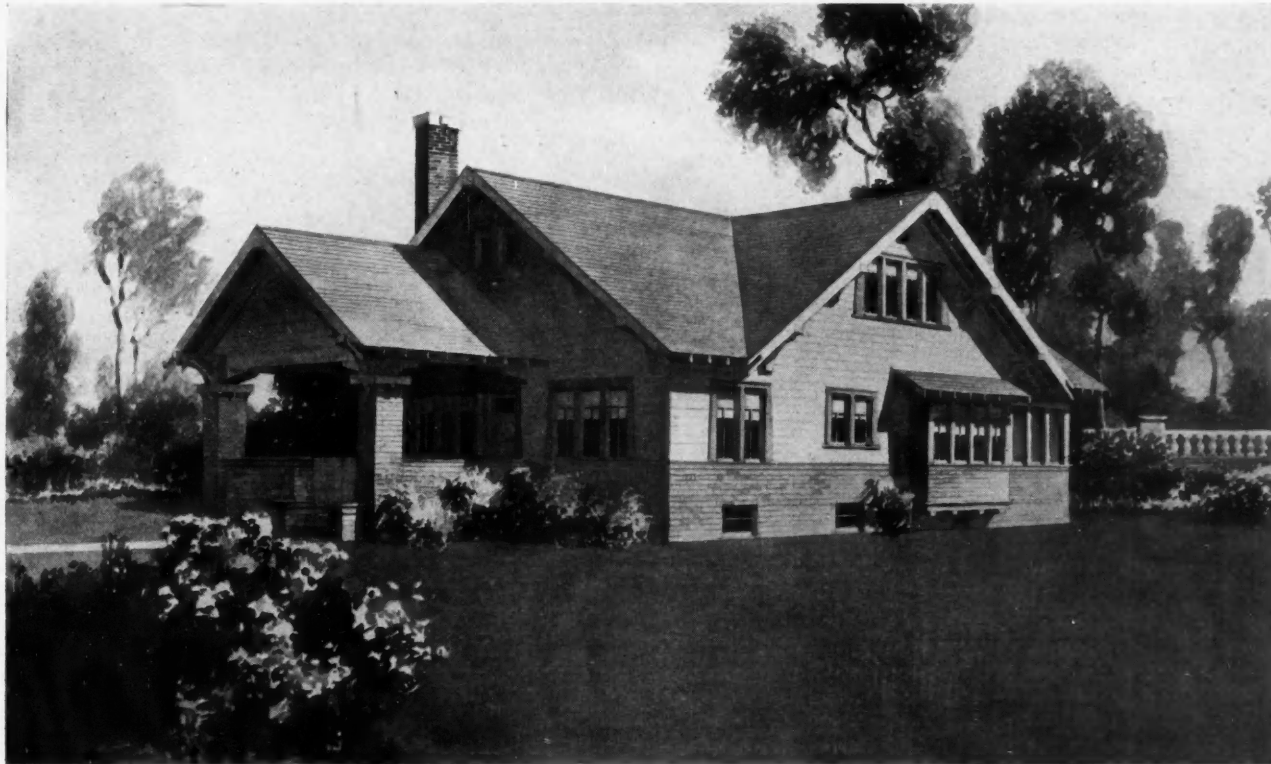

Seven-room bungalow, size 33 by 47 feet. Siding is of wide boards; foundation courses and porch pillars brick. We can furnish complete set of blue-printed working plans and typewritten specifications for only \$10.00 per set. Blue prints consist of basement plan; roof plan; first and second floor plans; front, rear, two side elevations; wall sections and all necessary interior details. Specifications consist of twenty-two pages of typewritten matter. Ask for Design No. 6541.

Seven-Room Brick and Wide-Boarded Bungalow

Here is a very home-like dwelling of the western bungalow type. The foundation courses up to the window sills are of brick; above, wide resawed boards are used. These are laid about 8 inches to the weather and have a rough surface which takes a stain, brown or dark green, very nicely, producing a rich, warm appearance.

The trim around doors and windows and around the cornice is stained or painted in a color contrasting with the rest of the house. There is a chance for a very artistic effect in this bungalow by properly choosing the colors for brick work, siding, and roof.

The interior of this bungalow is typical of the best modern arrangement. The living room is large, 14 by 19 feet, and connects freely with the dining room through a broad colonnade opening. The dining room measures 15 by 17 feet. Both of these apartments are elegantly finished with ceiling beams, arranged in an ornamental way.

The kitchen is well placed and is just the right size for easy housekeeping. The pantry has a place for built-in refrigerator, to be iced from the porch. The cellar stairs, down to the fruit and vegetable cellar, open handily from the kitchen.

This design is popular because of the fine down-stairs bedroom from which

opens the screened porch. One who has ever slept in a screened porch will never be satisfied with any other.

The bathroom opens from the down-stairs bedroom, and is of generous size. Note the two large closets on this floor.

Opening from the living room is a comfortable den or library 12 by 13 feet. The stairway goes up from here.

On the second floor are one large bedroom, a smaller room, designated "sewing room," toilet, and two large storage rooms.

An exceptional amount of good, useable living space is secured in this dwelling for a bungalow of its dimensions. For a building lot of 40 feet or more, nothing could be better.

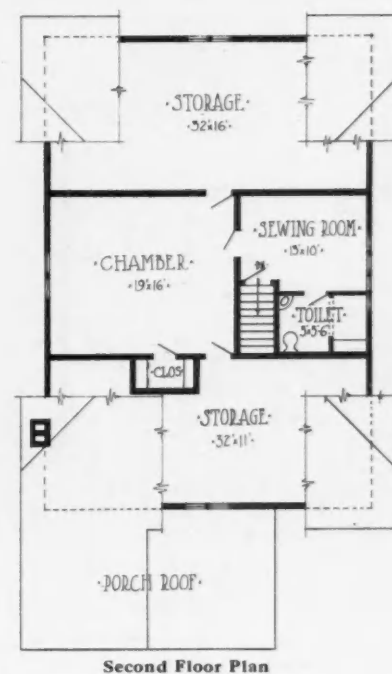

Seven-Room Gambrel House for Narrow Lot

All things considered, the gambrel roof house works out best for the moderate cost dwelling where every inch

of space must be utilized to the best advantage. The rooms on the second floor are full size, and yet, being "under the roof" they don't cost very much.

Much depends on how a gambrel

house is designed. This one is in perfect harmony with itself. The large octagon bay in front, and also the one at the side seem to go naturally with the shape of the roof.

Nicely arranged small residences to go on a narrow lot are scarce. This design measures only 24 feet in width. The length is 31 feet 6 inches. On the first floor are four good rooms; sitting room and dining room opening together, conveniently arranged kitchen, and a small down-stairs bedroom with clothes closet.

This is a snug home for cold climates, as the front porch is so well protected, and the vestibule keeps the cold air from the entrance out of the sitting room.

There is no reason for giving up the best part of a house to the stairway. Here the stairs are placed at the rear. They go up from the dining room, which is handy and desirable in a house of this size. On the second floor are three good sized bedrooms, bathroom, and six clothes closets.

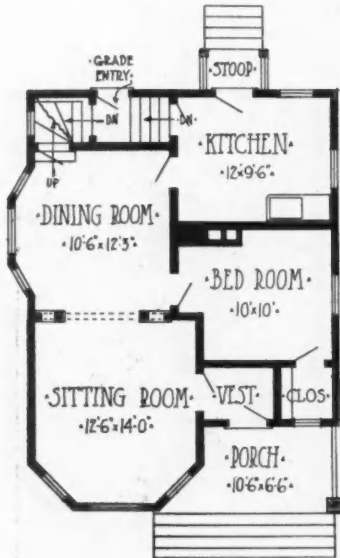

First Floor Plan

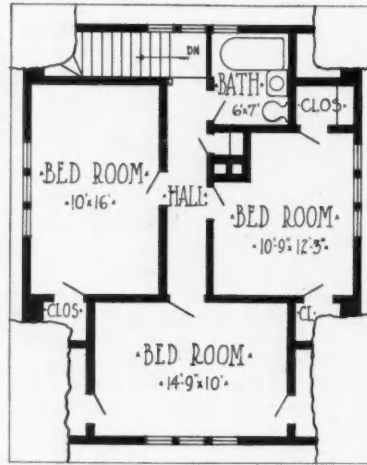

Second Floor Plan

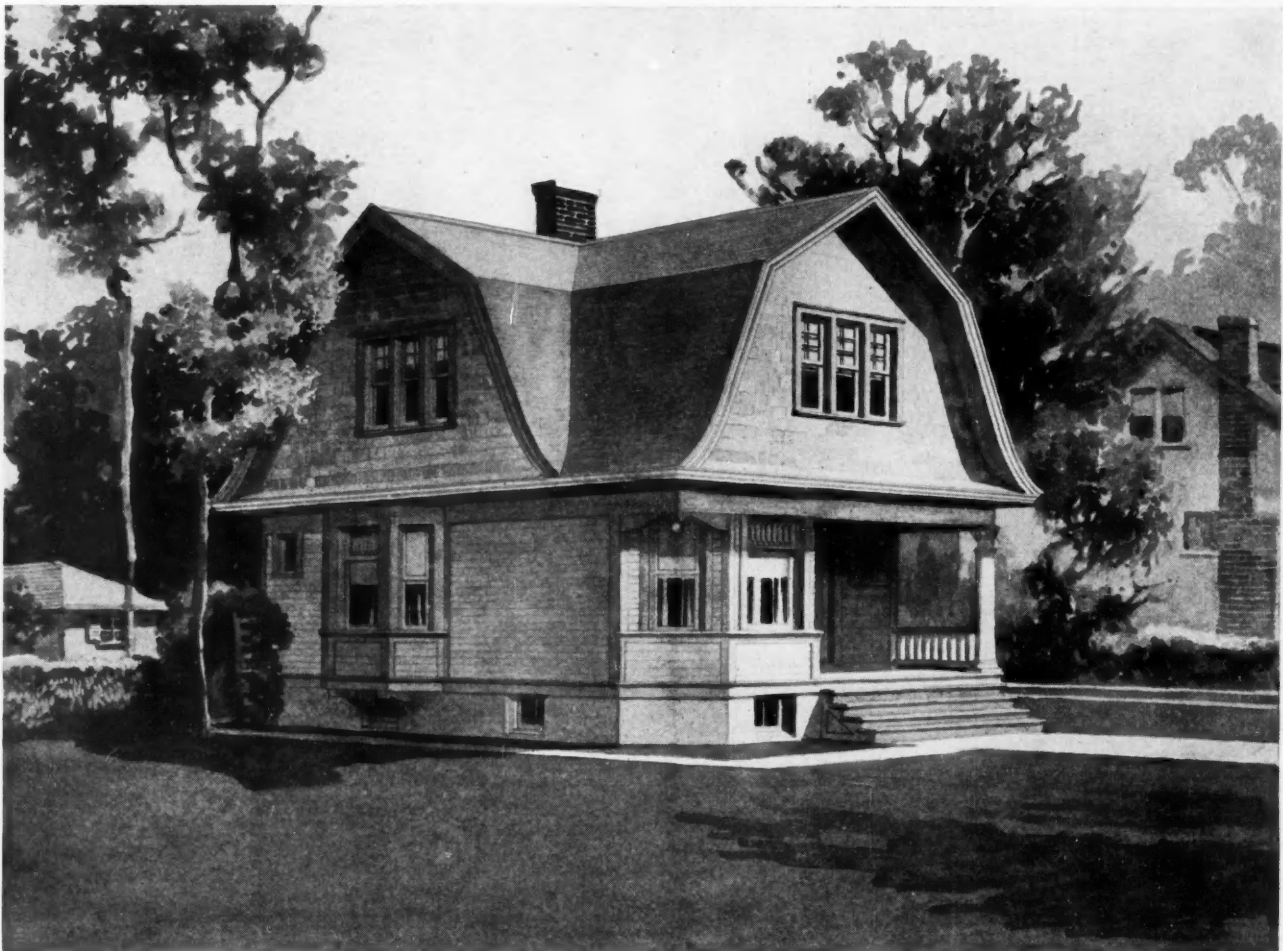

Seven-room gambrel roof dwelling, size 24 by 31 feet 6 inches. First story sided; gable ends and roof shingled. We can furnish complete set of blue-printed working plans and typewritten specifications for only \$10.00 per set. Blue prints consist of basement plan; roof plan; first and second floor plans; front, rear, two side elevations; wall sections and all necessary interior details. Specifications consist of twenty-two pages typewritten matter. Ask for Design No. 6542.

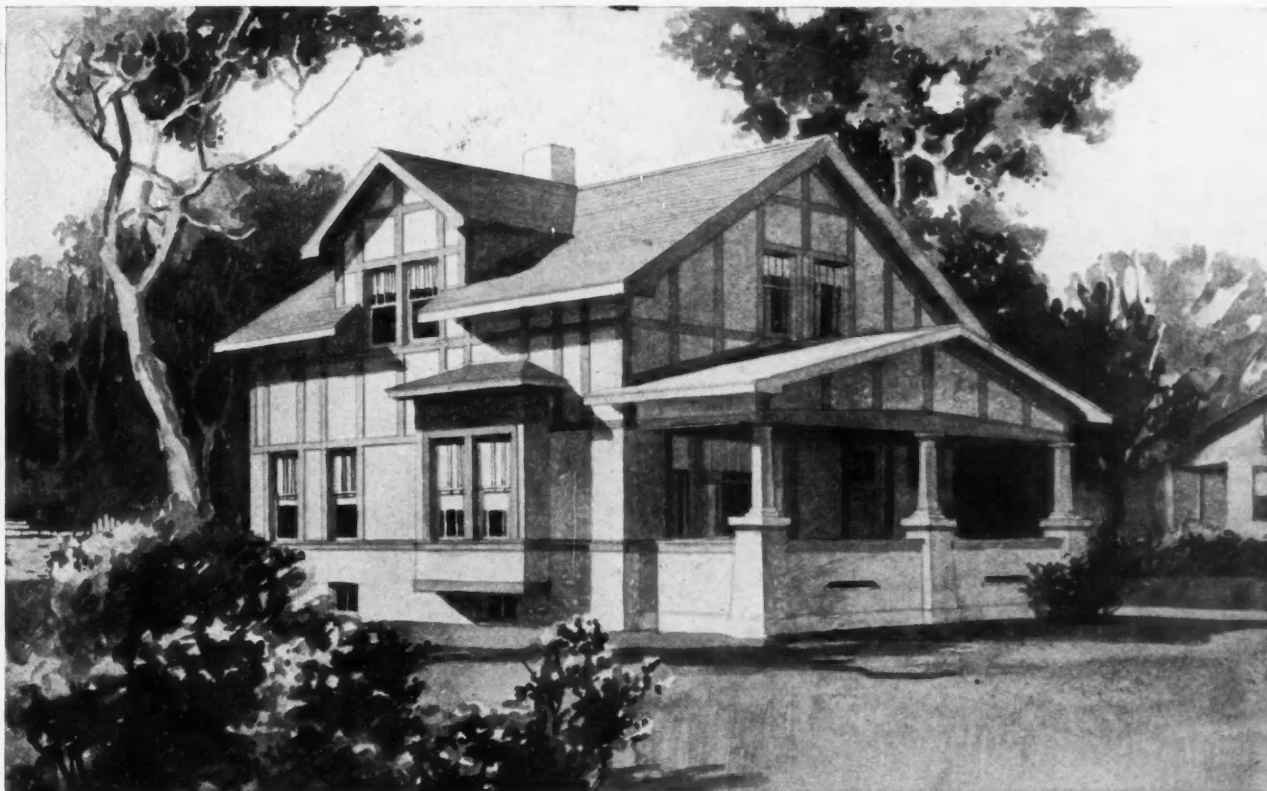

Artistic six-room stucco residence with English half-timber paneling. Size 28 by 33 feet. We can furnish complete set of blue-printed working plans and typewritten specifications for only \$12.00 per set. Blue prints consist of basement plan; roof plan; first and second floor plans; front, rear, two side elevations; wall sections and all necessary interior details. Specifications consist of twenty-two pages of typewritten matter. Ask for Design No. 6544.

Stylish Six-Room Paneled Stucco House

The popularity of cement plastered or stucco houses continues. This one is given an ornamental appearance by the use of exposed timber paneling in the upper story. This is known as English half-timber work, although the construction is, of course, different from the old Elizabethan work after which it is modeled.

Imagine this residence with cement work painted cream color or tan, and the trim painted dark brown or olive green. Or many prefer to leave the cement its natural gray color, painting the wood trim to contrast strikingly.

Of stylish up-to-date exterior, the inside arrangement of this house is in every way modern, making good the promise of the outside. Entrance from the porch is into a square reception and stair hall. To the left is the large, well lighted living room with open fire place in one corner. The dining room is in the back. Although centrally located, the kitchen is well insulated from the other rooms. The pantry separates it from the dining room and the cellar stair hall from the front of the house. This effectively cuts off both noise and cooking odors.

Housewives will approve of this kitchen with its broad, well lighted work shelf and sink, and handy built-in cup-

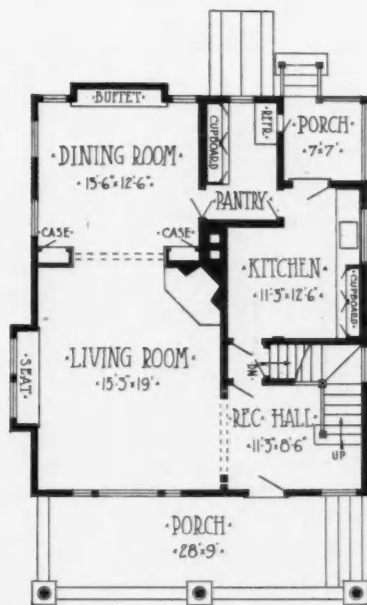

First Floor Plan

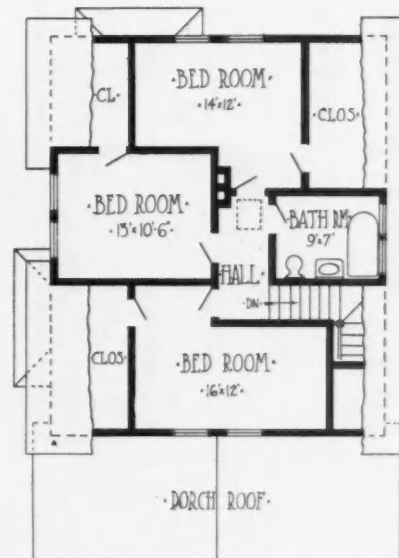

Second Floor Plan

board. The refrigerator is in the pantry, and is iced from the back porch.

On the second floor are three good sized bedrooms, bathroom, and three extra large closets.

The outside dimensions of this house are 28 feet by 33 feet, not including porches. This makes a very desirable residence for a city or suburban building lot of 30 feet or wider. While it

is a decidedly economical house to build, it has an up-to-date, "dresy" appearance which discriminating home builders appreciate. The story-and-a-half treatment keeps the lines of the building low and broad. This place would never have that bleak appearance, so often carried by taller houses, especially when new, before the shrubbery has had time to grow.



Rich eight-room brick residence. Size 31 by 34 feet 6 inches. A popular hip-roof design. We can furnish complete set of blue-printed working plans and typewritten specifications for only \$15.00 per set. Blue prints consist of basement plan; roof plan; first and second floor plans; front, rear, two side elevations; wall sections and all necessary interior details. Specifications consist of twenty-two pages of typewritten matter. Ask for Design No. 6543.

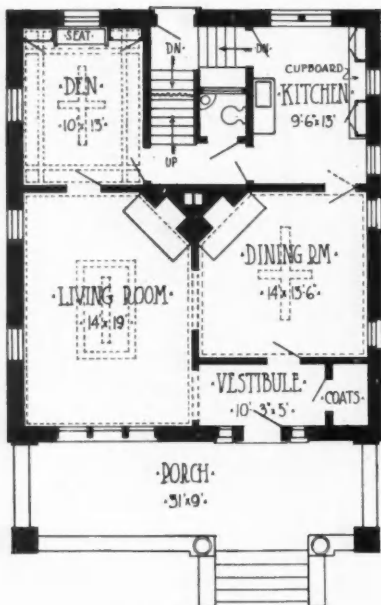

First Floor Plan

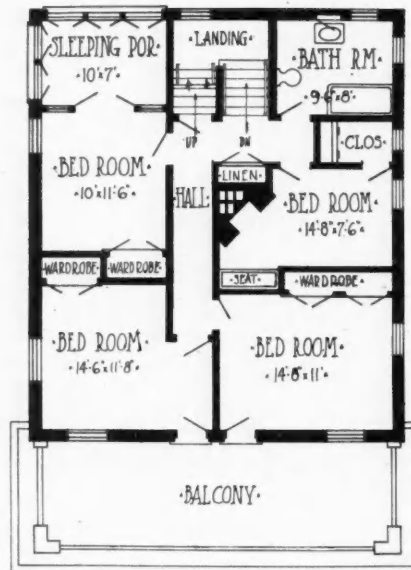

Second Floor Plan

Elegant Eight-Room Brick Residence

A permanent residence of the most approved, conservative, hip-roof design is presented. The building is almost square in outline, 31 feet wide by 34 feet 6 inches deep. Every square inch is made use of, and no money has been used on angles and turns and projections, which complicate the wall con-

struction and roof construction, without returning the equivalent in added comfort to the interior.

This house, constructed of one of the modern rough texture bricks, perhaps tan color or dark brown, and laid with prominent mortar joints of a contrasting color, presents a striking and attractive picture.

The roof illustrated is rather novel;

every fourth row of shingles is laid double—a trick to emphasize the horizontal lines.

From the broad front porch entrance is into a large vestibule which opens to the left into the living room, and also straight ahead into the dining room. A clothes closet to the right is provided. Back of the living room is the library or den. The kitchen occupies the fourth corner.

The dotted lines in the three main rooms indicate ornamental ceiling work in connection with the electric lighting fixtures.

The stairway in this house goes up from the inside hall. It is easily accessible from the library and from the kitchen. Those who do not care to have the best part of the house taken up by the stairway will appreciate this arrangement.

On the second floor are four large bedrooms, each with good wardrobe and closet space. One bedroom has screened sleeping porch, separated from it by glazed partition with double doors. The two front bedrooms open onto the balcony over the front porch.

The bathroom is on this floor, directly over the kitchen and first floor toilet, thus keeping all plumbing fixtures in line—an economy point to be considered.

Low Cost Six-Room Dwelling

For a modest little home, nicely arranged and of good appearance, nothing could be better than this story-and-a-half frame dwelling. The width is 24 feet, the length 36 feet. There are six rooms, three on each floor.

On the first floor are parlor, 14 by 17 feet 6 inches, and dining room, 13 feet 6 inches by 14 feet. These rooms connect by means of double sliding doors. A three-window bay lights each room. The kitchen is well away from the other rooms, yet is arranged to save steps. It is a small kitchen, as preferred by most housekeepers these days. The pantry is of good size, and there is also a large lighted closet off the dining room.

Just in front of the kitchen there is a little back hall with stairs leading down to a grade entrance and to the cellar. On the second floor are three well lighted bedrooms and the bathroom.

One thing the women folks all like about this house is the closets. There are five of them on the second floor and three on the first floor. They seem to be placed every time just where a closet is most convenient.

This house has been designed to use stock sizes and patterns of lumber and mill work in order to hold down the cost at every point, at the same time producing a substantial, cozy home.

It is surprising the amount of room there is in this dwelling. From the outside it seems to be a snug, cosy, little cottage; but within the rooms are large and well laid out.

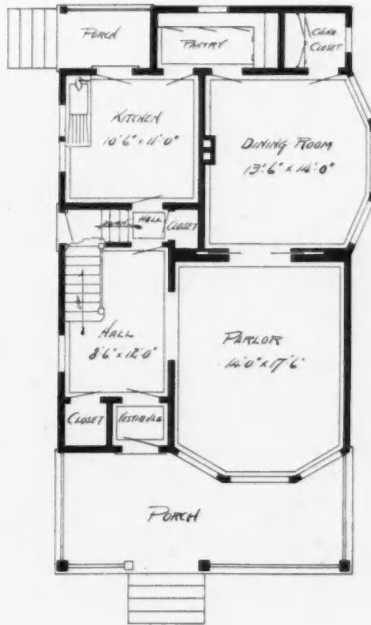

First Floor Plan

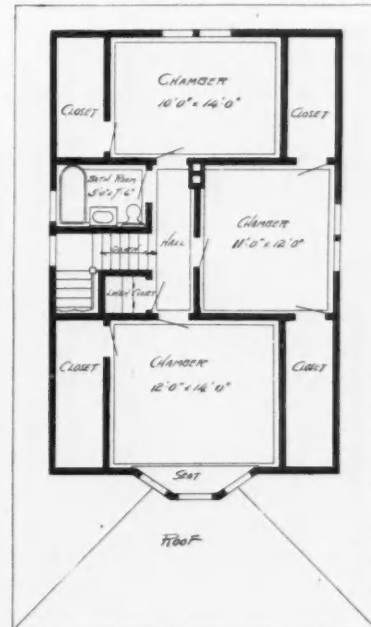

Second Floor Plan



Very practical six-room, story-and-a-half cottage. Size 24 by 36 feet. An economical house to build. We can furnish complete set of blue-printed working plans and typewritten specifications for only \$8.00 per set. Blue prints consist of basement plan; roof plan; first and second floor plans; front, rear, two side elevations; wall sections and all necessary interior details. Specifications consist of twenty-two pages of typewritten matter. Ask for Design No. 8539.



Six-room cement plaster bungalow. Size 38 by 43 feet 6 inches. A well arranged modern dwelling. We can furnish complete set of blue-printed working plans and typewritten specifications for only \$10.00 per set. Blue prints consist of basement plan; first floor and roof plans; front, rear, two side elevations; wall sections and all necessary interior details. Specifications consist of twenty-two pages of typewritten matter. Ask for Design No. 6545.

Modern Six-Room Cement Plastered Bungalow

The genuine bungalow—all rooms on the main floor—that is laid out in a really desirable way is something of a rarity. For a good many reasons the sleeping rooms in a house should be somewhat away from the living room and dining room. They should be quiet, and also located so that privacy is possible. In a good many alleged bungalows a bedroom is often found opening directly out of the living room; sometimes out of the dining room. While this may not always be objectionable, there are times when such placing of the rooms cuts down their usefulness one-half, and makes them inconvenient.

The layout of rooms illustrated in the diagram for this design deserves careful study along this line. The three bedrooms (one is labeled "sewing room"), are placed together at the back of the house. They all open into a 6 by 13 foot inside hall. Into this same hall the living room, kitchen and bathroom also open. With the living room door closed the front of the house is entirely separated from the rest.

As in all truly up-to-date residences the living room is very large, 16 feet 6 inches by 23 feet. There is an open fire place at the far end and a cozy built-in seat in the window nook at the front.

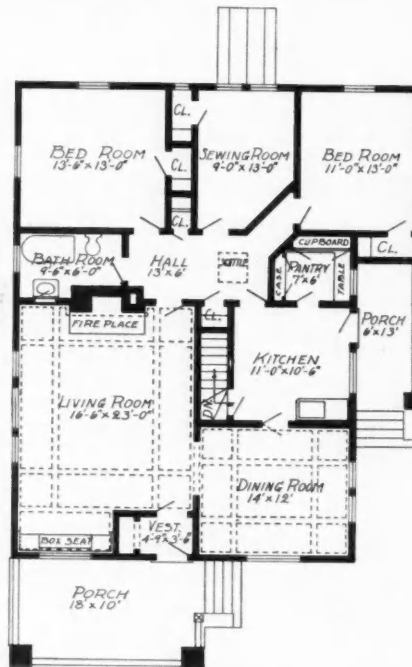

Main Floor Plan

Both this room and the adjoining dining room have ornamental ceiling beams. The dining room is a pleasant apartment, 12 by 14 feet. The kitchen is just back of it. The side porch is the kitchen porch, a desirable feature. Housekeepers will relish the large, well lighted pantry with its broad work shelf and two cupboard cases.

The cellar stairs go down out of the kitchen.

This bungalow requires a good sized lot. Fifty feet would do nicely. Construction is standard balloon framing, sheathed and papered and then covered with metal lath. The cement plaster is laid on in three coats, and forms a durable fire-resisting, waterproof siding. The final finishing cost of the stucco may be treated in any one of several ways. It may be worked rough—what is called "slap-dash," or "pebble-dash"—or it may be finished smooth. Many prefer the rough cast finishes, as having more character.

In color also there is a wide selection. The natural cement gray is a pleasing tone, harmonizing nicely with window, door, and cornice trimmings of white, light green, or yellow. Or the cement work may be painted darker and some striking effects worked out. Special paints are offered that not only color the cement surface, but also waterproof and preserve it.

This design, illustrated, will work out very attractively in any of these styles, and will blend naturally with the building site to produce a thoroughly desirable home place.

When building a home it is always wise to select a popular, distinctive design; for such will never stand vacant waiting a tenant or purchaser.



How to Do Work Fast—Setting Door Jambs

By I. P. Hicks, Builder and Estimator

THE setting of door jambs is more or less a particular job, and with some it is rather slow work. It is like all other work—not so slow if you know how to proceed to the best advantage. To begin with, it will well pay every contractor to be quite particular about setting partitions. Be quite sure that partitions are set plumb and true. It will save quite a bit of time setting door jambs if the studding are set just right. Partitions are often set out of the last end of the studding after all the best and straight studding have been picked out and used up in other parts of the work. This, of course, can not always be avoided, but if it is a possible thing, save out enough straight studding to set next to the doors. If the studding are carefully set, the opening need be only $2\frac{1}{2}$ inches wider than the door to be used. Some allow 3 inches, but this leaves too much space between the jambs and studding to wedge up and fur out. If the studding are as they should be, $\frac{1}{2}$ inch space between the studding and jambs is plenty for adjusting and plumbing up the frame.

Shingles are the best to use for furring out and to wedge up with. By taking two shingles, slipping one past the other, they can be adjusted to any required thickness very quickly, and it makes much faster the work of truing up door jambs. It is often the case that floors are not exactly level, but it is necessary that the head jamb be level, otherwise, when the side jambs are plumbed up the frame will not be square.

To begin with, stand the frame in the opening temporarily and try the level on the head jamb. If any out of level, make a mark on the jamb on the high side, showing how much it is out of level and cut this much off the bottom of the high side jamb. Always put a small mark on the jamb and on the floor so that you will be sure to get the frame back in the way it belongs. Also try your level on the studding to see which side is the nearest correct as to being straight and plumb, then nail in the jamb on this side first, being careful to see that it is just right, then true up the other side, keeping the door the same width from top to bottom. It is a good plan to have a board cut to width of doors for a bottom guide.

It is far the best to have a level attached direct to a straight edge for setting door jambs. It will save much time and is more accurate. There are on the market good level and plumb glasses that can be had for this purpose. There are some also that are no good because of the insecure adjustment. To be good the adjustment must be a substantial feature of the tool, otherwise a few jolts will displace the level glass and then it is an unreliable tool. Select a level that is quick acting.

When the bubble stops on the center of a quick-acting plumb or level it is more likely to be right than the slow-moving one, because the real slow level or plumb will keep moving so long after you think it is right that you can never tell when anything is exactly right by it.

Any good mechanic should be able to take door jambs in the knock-down as they come from the mill and be able to nail them together and set them properly in place in the building at the rate of not less than two frames an hour, and I know of men that will do three frames an hour. I do not mean to case the opening; what I mean is nailing the jambs together as a jamb frame, and setting this in the opening, wedged up true and nailed in place ready to case up. It is a good thing to nail a lath across the top and bottom on one side, letting them stick over about the same as a casing; this will serve as a sort of guide in setting the frame just right for casing-up. One can not be too careful in this important work of setting frames.

The case of finishing and the quality of the finished work depends to a large extent upon how well the jambs are set. Real good jobs must be good all the way through from start to finish. It is possible to give and take a little here and there and to cover up some bad work; but that is not what the readers of the AMERICAN CARPENTER AND BUILDER want; and I do not want it—I want to see every reader a wide-awake man, one that always stands ready to “holler” hurrah for the best. Let our motto be: First, do your work right; after that, do as much of it as you can by the most approved methods.

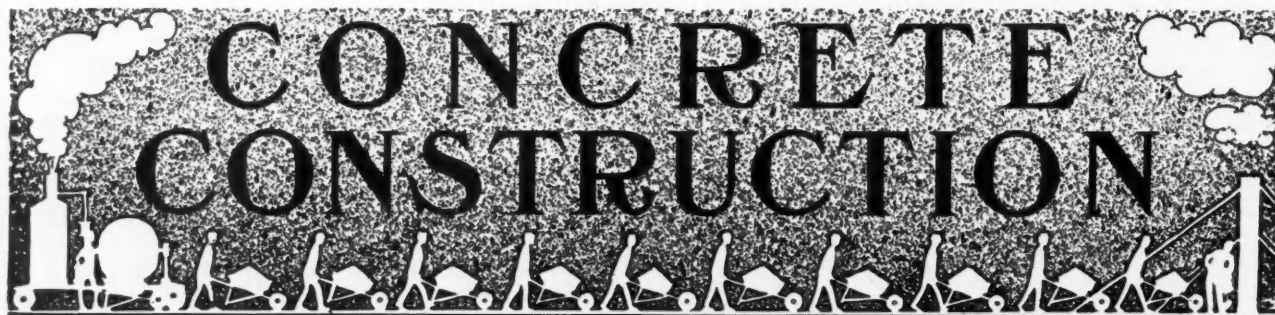

Freezing Weather no Bar to Concrete Work

PRESENT-DAY CONTRACTORS USING SIMPLE HEATING EQUIPMENT AND OBSERVING WELL-TESTED RULES TO PUSH FORWARD THEIR WORK IN THE COLDEST SEASONS

By Paul Chesterton

EXPERIENCE in the handling of concrete has shown the cement worker that it is no longer necessary to suspend all concrete construction during the cold months of the year for fear that the concrete may freeze and thus become valueless as a building material.

Until our builders became accustomed to handling concrete in a scientific manner, and began to recognize the chemical changes which take place during the setting of concrete, it was the custom to stop all important concrete work just as soon as cold weather set in. These workers now realize that a definite period of time is necessary for the chemical action between the cement and water to take place; and if this action is not interfered with during this period of setting, there is but little danger of disastrous effects from freezing alone after this time has passed.

Our experimenters have determined that it takes a considerable amount of time for the concrete to harden and come to its full strength, even after this preliminary setting stage has passed. This knowledge helps the concrete worker in determining the amount of time that should elapse between the placing of the concrete and the removal of the forms which hold the concrete in position until it has obtained its own true strength.

Expensive concreting machinery and equipment are now used practically throughout the whole year, thus allowing a great saving in the expense of maintaining an organization and plant equipment such as is used in work of any great importance or magnitude. Idle machinery and plant in general represent an investment upon which the interest charges are increasing, while no returns are coming from it to the owners. It is true that the handling of concrete during freezing weather is more expensive than under ordinary conditions, but the additional expense is so slight as compared with idle equipment, that the balance is in favor of continuous working of plant.

There is no longer need for specifications to demand that concreting be stopped at the approach of cold weather, if provision is made that care shall be taken during this period of the year to place the material in the forms at a temperature such that freezing will not

occur until after the concrete has set, and that precautions shall also be taken to maintain the heat in the concrete as long as necessary for proper hardening after setting.

While it is generally accepted by engineers at the present time, that concrete can be handled, in spite of cold weather, in such a way as not to invite failure, it is also true that unless the contractor provides the proper plant for observing precautions necessary during construction, work of no kind should be attempted at temperatures below 32 degrees Fahrenheit.

Why Precaution is Necessary

Protection against freezing is necessary on account of the effect of frost upon the surface finish of the work where alternate freezing and thawing occur, and also upon the structure of a mass of concrete itself. Surfaces will scale off to the depth of about 1/16 of an inch, thus disfiguring the face of the work. Alternate freezing and thawing will cause a breaking down of the body of the concrete, resulting in a worthless condition.

Another condition which is not so plainly brought to notice as those just referred to, is the dangerous effect of the delayed setting of the cement in the concrete. Cold may delay this setting for so long a period that forms may be removed from under load-bearing members before the members have taken on their full strength. Cases have occurred where the cement was so delayed in setting that after forms were removed the members did not have strength enough to hold even their own weight in place. This may readily be seen to be a very dangerous condition of affairs in any type of building.

In sidewalk work, unless precaution is taken to protect the surface of the walk from freezing until the material has taken on the required amount of hardness, there is danger of scaling to such an extent that the walk will be ruined for service.

Effect of Frost on Aggregates

Frost may affect aggregates in two ways. A coating of ice or frozen material on the particles of sand or crushed stone will prevent the bonding action necessary between the particles when the cement grout is

mixed into the mass in making concrete. All particles of sand and stone should be clean, and free from foreign material, so that the mixture of stone, sand, and cement may readily become a monolithic mass through the chemical action of the water on the cement. Where the bonding action of the cement is delayed by the melting of ice from the surface of the particles, the setting process has advanced so far that the firm bond which would occur under normal conditions has been partially lost. Cold sand and stone will delay the setting of the cement in just the same manner that cold from any other source will delay the same action. Experiments have proved that the setting of the cement is hastened by a warm condition in the mass of material, thus showing that this condition should be approximated for most favorable results during cold weather.

How to Prevent Damage from Cold

The methods in common use for overcoming the danger from freezing may be summed up under two general headings:

(1) The aggregates may be heated to such a degree that they will stay warm until the concrete has set; or (2) the freezing point of the concrete mixture may be lowered by the use of some material mixed into the concrete so that, within a limited range of temperature, the concrete will set before it freezes.

Heating the Materials

If actual heating is to be employed, the sand and stone may be heated, or the mixing water may be heated and used with cold aggregate. If the mixing water alone is heated, there is likely to be danger of cooling of the water in melting snow or ice from the particles of aggregate, thus preventing the actual warming of the aggregates which is desired.

Where the freezing point of the mixture is to be lowered, the mixing water may contain a small percentage of common salt or of calcium chloride.

In some cases a combination of any two or all of these methods may be used.

Where the sand and stone are heated, some form of heater is necessary. The sand and stone may be piled over metal stoves of a crude nature, or may be



Fig. 1. A Type of Portable Sand-Heater

heated by the use of steam pipes or jets either in an enclosure or in the open. Figs. 1 and 2 show types of apparatus used in heating sand and crushed stone. This type of apparatus may consist of almost anything from a piece of sheet metal bent into a curve and inverted, up to an elaborate portable oven on wheels. Metal culvert pipe has been used to good advantage in many cases for heating materials, but is of



Fig. 2. Culvert Pipe with Fire in One End, for Heating Aggregates

greater service when fitted with a small stack and fired from one or both ends. Old boilers or other scrap material which are of no service for any other purpose may be used profitably in this line of work, provided they are not too heavy to move around as the case demands. The small portable heater shown in Fig. 1 is very useful in work where the location changes rapidly, as in the case of street-railway or pavement work.

Where sand and stone are to be heated by steam, the steam pipes may be arranged in the form of coils over which the materials are piled; or the steam may be introduced into piles of the material by attaching short pieces of iron pipe to lengths of hose leading from the boiler, and sticking these pipes into the piles of material at various places, thus allowing the steam to escape through the materials. Where the latter procedure is followed, pieces of canvas or tarpaulins should be placed over the piles of material.

In large building work, it is not uncommon to have material storage bins fitted with 1½-inch diameter pipes, in which small holes are drilled 2 or 3 feet apart so that jets of steam may escape and circulate through the materials.

Crushed stone requires much more heat than sand, or sand and gravel mixed, on account of the greater volume of the air-spaces in the crushed stone.

The use of steam in heating aggregates has the advantage of not damaging the material which is placed near the heater, as will often be the case where sand or stone are piled directly upon a very hot surface. Contact with a hot surface may cause sand to turn red, and stone or gravel will soften or crack. A temperature not to exceed 150 degrees Fahrenheit will generally prove the most satisfactory, although the average ranges from 100 to 150 degrees.

Where the mixing water is heated, several forms of heating devices may be used with success. A steam pipe may be run into a water barrel, and left with an open end controlled by a valve; or the water may be heated in a tank by means of a steam coil placed therein. Another method is by a fire in a furnace under the tank, as shown in Fig. 4. Where mixing water is used rapidly, an independent heater is preferable to one supplied with steam from the boiler used in con-

nection with a mixing or hoisting plant, since it is often difficult, in a small boiler, especially in cold weather, to maintain a steam pressure adequate for the combined work required of the boiler.

Engineers differ on the correct temperature to which the mixing water should be heated, but aver-



Fig. 3. Sand and Gravel Heated by Steam

age limits may be set between 100 and 200 degrees F. Many consider that 200 degrees may injure the cement, but there does not seem to be any well founded reason for this fear.

Although limits have been stated for temperatures to which the aggregates and water should be heated, it has been found by practice that concrete deposited in the forms at a temperature of from 50 to 70 degrees F. will produce satisfactory results, especially where an effort is made to retain this heat in the concrete, either by means of protective coverings, or by heating the air in contact with the freshly poured material to approximately this same temperature.

Use of Salt and Calcium Chloride

A simple method of preventing damage from frost in cases where the temperature of the air surrounding the concrete is near the freezing point, is to add a small percentage of common salt to the mixing water. This percentage varies with different engineers; but a common understanding seems to be that 1 per cent of salt for each degree of fall of temperature expected will produce satisfactory results for temperatures above 22 degrees F. This percentage is figured on a basis of the weight of water used; that is, 1 lb. of salt would be used for each 100 lbs. of water, for each degree fall of temperature.

The objection to the use of salt in the mixing water is that it may weaken the strength of the concrete during setting and may also delay the setting of the cement since it merely adds to the effect of cold upon the set of cement. Again, the use of salt in concrete for reinforce work is likely to produce disastrous effects on the steel used for reinforcement. It is generally considered that the time necessary for setting is considerably increased, and the strength of the concrete at short periods is lowered by the use of any

appreciable amount of common salt.

Calcium chloride has been used with success in quantities not exceeding 2 per cent of the weight of the cement used. This material should be employed with care, since a larger percentage may hasten the set of the concrete to such an extent that it would be difficult to handle.

Maintaining Temperature in Concrete

As already pointed out, it is of the utmost importance to prevent chilling of the concrete during the setting period. Thus it would seem policy—as long as care has been taken to warm the aggregates and mixing water or to lower the freezing point of the mixture—to add to this effect by providing some means of preventing, as long as possible, the temperature of the concrete from falling. This action will aid in hastening the final hardening of the material.

There are many ways used for providing this maintenance of heat for a time after the concrete has been put into place. Probably the most common and the easiest way is to cover the concrete in such a way that the initial heat cannot escape; or, if the weather is rather severe, additional heat from either salamanders or steam pipes may be used to keep the work warm. Salamanders are large sheet metal stoves open at the top, in which coke is burned as an open fire. Steam heat may be used either in the shape of live steam escaping from an open pipe and held down upon the work by covering the latter with canvas or tarpaulins, or by enclosing the work with proper coverings and allowing the heat from steam coils or radiators to be in contact with the new concrete.

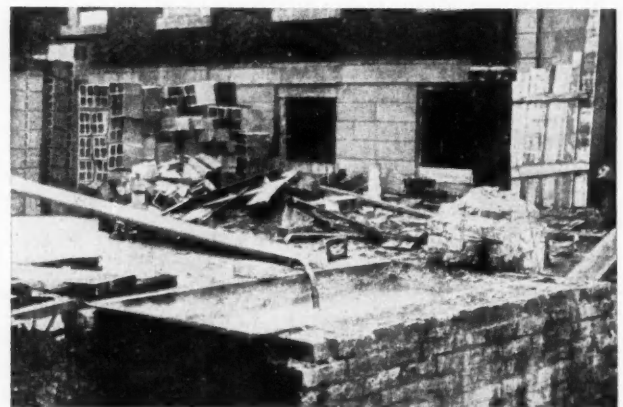

Fig. 4. Tank Water-Heater Built in Over Brick Furnace

As a sample of the method of using salamanders in building work, after building the forms for the first-story columns and second-story floor-slabs, beams, and girders, but before depositing any concrete, the entire story is housed in with canvas and heated to a temperature of about 60 or 70 degrees F., with salaman-

ders placed at scattered points within the enclosure. The forms for wall columns of the next story above are then placed, and this story also housed in with canvas as soon as possible. Enough canvas is necessary to house in at least two stories at a time, and salamanders should be kept burning on each floor during the time the housing is used. Where the wearing surface is placed with the floor-slab, it is necessary to have housing in place and salamanders burning on each floor before depositing the concrete; otherwise it would be impossible to finish the surface of the floor properly. Fig. 5 shows the method of finishing a floor while the heat is supplied by salamanders suspended from above.

In building work, it has been found that one salamander is required for every 500 to 800 sq. ft. of floor area, in order that the temperature of the air may be maintained at about 60 degrees F. by the use of good coke. In ordinary construction, there is no need of suspending the salamanders unless it is necessary to work on the space under them.

In heavy work where thick masses of concrete are deposited, or in side walls and flat slabs, it may only be necessary to protect the work by covering the freshly poured concrete with building paper or boards, and then with a layer of straw or dry manure 10 to 12 inches thick. It has been found that a layer of manure of the above thickness, if kept dry, will protect heavy work from freezing, for days, at a temperature as low as 10 degrees F. The manure should not be placed in contact with the concrete, on account of the discoloration which may occur. In some cases where manure has been applied directly upon concrete, the surface of the concrete has afterwards suffered slight disintegration. Tight, heavy timber forms should also be used in cases where this form of protection is to be employed.

Chemical Action Raises Temperature

Investigations recently made by W. D. Maxwell, Assistant City Engineer, Des Moines, Ia., shows that in the hardening of concrete the process is accompanied with appreciable rise in temperature. The investigations were made in connection with the construction of a concrete bridge in Des Moines. Readings were taken on thermometers placed in pipes from 5 to 10 feet below the tops of the piers, and from 3½ to 10 feet back from the outer faces of the concrete. During the period of hardening, the thermometers showed a variation in temperature of from 15 to 20 degrees, the maximum of increase being reached between 7 and 10 days after the concrete was poured in place. After 10 days the temperature fell steadily to normal. This rise in temperature seems somewhat remarkable, and goes far toward explaining why concrete in large work can be successfully laid in rather cold weather without special precautions.

The amount of additional expense involved in winter jobs will depend mainly upon the character of the

work under construction and the methods of protection used. Labor is more plentiful and cheaper in the winter than during the summer months; but is not so efficient, especially during very cold weather. Materials may not vary in price; but deliveries are more prompt and can be counted upon with greater certainty during cold weather. Although a little more outlay is required for plant and maintenance of same, it has been found that the cost of winter work, where carefully planned equipment is used, will show an in-

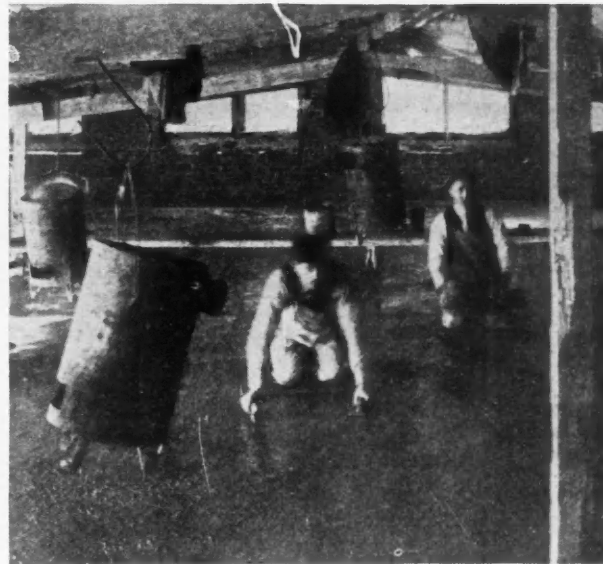

Fig. 5. Salamanders Suspended from Hooks Above, During Finishing of Floors

crease of from 2 to 5 per cent of the total cost of the work at other seasons. It is true that a large amount of lumber will be needed for forms, since they will have to be left in place longer. There will also be an initial outlay for canvas necessary to enclose the work, where heat is to be maintained in the interior of the building.

In all concrete work performed in cold weather, it is a fact that one dollar spent in heating the materials at the time of mixing is of more effectiveness than several dollars spent in trying to heat cold concrete after it is in place.

Forms

Tight, well-made forms of heavy material are a necessity where cold weather is to be met, or where it is desired to hold the temperature in concrete. This is more essential in thin structures than in massive walls and foundations, for the latter will hold their own heat longer on account of their thickness. Plain mass work, such as retaining walls and abutments, will not require the same care and protection as thin walls, columns, beams, and floor-slabs.

Lumber forms are non conductors, and will retain the heat in the concrete up to a certain point; but the concrete should be protected on top, as already described.

In the case of thin walls, as in the case of buildings where the walls are not enclosed in canvas and some

form of artificial heat supplied, additional protection may be obtained by the method shown in Fig. 6. Heavy paper is nailed to the vertical posts of the forms, thus leaving an enclosed air-space between each pair of posts. These air-spaces will have about 15 degrees higher temperature than the outside air.

Length of Time Heat is Needed

It is commonly considered that mass concrete which has been deposited warm in the forms and protected for at least 48 hours from freezing is no longer in danger; although it is preferable to allow it a few days

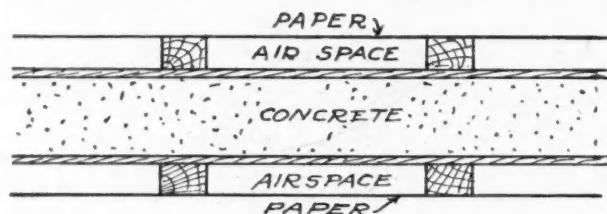

Fig. 6. Paper Tacked to Wooden Supports to Protect Concrete from Frost

more for hardening, if possible. Concrete takes on hardness and strength very slowly at low temperatures. For bridges, buildings, and other thin reinforced concrete work where the stresses in the concrete are other than direct compression, additional protection is necessary. Such structures should have time to take on considerable strength before the forms are removed, or before the temperature of the concrete is allowed to approach the freezing point. In some instances the work has been kept warm for 4 to 9 days by the use of heaters. If concrete freezes before it is well hardened, it is likely to appear hard and well set when it may be really only frozen hard, and not capable of carrying its own weight. Where the supporting forms are removed from under concrete of this nature, damage is sure to result.

Rules: When Safe to Remove Forms

The best contractors have definite rules for the minimum time the forms must be left in ordinary weather; and then these times are lengthened for changes in conditions, according to the judgment of the foreman. Conference with a number of prominent contractors in various parts of the country indicates substantial agreement in the minimum time to leave forms in place. As a guide to practice, the following rules are suggested, these following in the main the requirements of one large construction company.

Walls in mass work—1 to 3 days, or until the concrete will bear pressure of the thumb without indentation.

Thin walls—in summer, 2 days; in cold weather, 5 days.

Slabs up to 6 feet span—in summer, 6 days; in cold weather, 2 weeks.

Beams and girders and long-span slabs—in summer, 10 days or 2 weeks; in cold weather, 3 weeks to 1 month. If shores are left without disturbing them, the

time of removal of the sheeting in summer may be reduced to 1 week.

Column forms—in summer, 2 days; in cold weather, 4 days, provided girders are shored to prevent appreciable weight reaching columns.

Conduits—2 or 3 days, provided there is not a heavy fill upon them.

Arches—of small size, 1 week; for large arches with heavy dead load, 1 month.

All of these times are, of course, simply approximate, the exact time varying with the temperature and moisture of the air and the character of the construction. Even in summer, during a damp, cloudy period, wall forms sometimes cannot be removed inside of 5 days, with other members in proportion. Occasionally, too, batches of concrete will set abnormally slowly, either because of slow-setting cement or because of impurities in the sand; and the foreman and inspector must watch carefully to see that the forms are not removed too soon. Trial with a pick may assist in reaching a decision.

Beams and arches of long span must be supported for a longer time than short spans, because the dead load is proportionally large, and therefore the compression in the concrete is large even before the live load comes upon it. ❖

"Model Village House and Yard" Competitions

Two important competitions will be opened this year in Minnesota, intended to directly benefit the people throughout the state, and to demonstrate the application of art to home needs and practical usages. Following the successful "Model Farm Home" competition of a year ago, the Minnesota State Art Commission has offered \$500, to be awarded in six prizes, for the best design for a "Model Village House"; this house to be applicable to both rural and urban needs. It is the first time in the history of any state in the Union that such problems have been promoted by state competition and funds. There will also be offered \$350, divided into five prizes, for an architectural landscape competition. This competition has been called a "Model Farm Yard." It will be applicable to rural and village needs. All of the information gathered from these two competitions will be turned over to the people of the state in the early spring; the ultimate result will be that of approaching the problem "Town and City Beautiful."

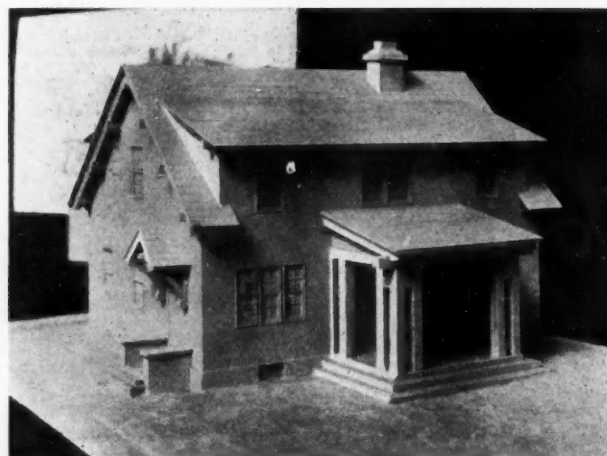

Miniature of First Prize Farm House in Last Year's Competition. (For Plans see May, 1913, "A. C. & B.")

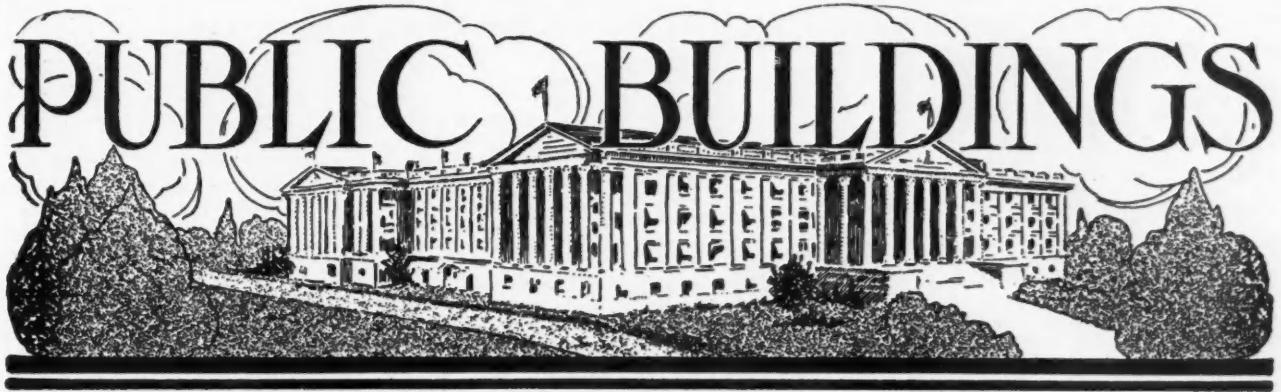

Modern School at Burnham, Ill.

The four-room school building recently dedicated at Burnham, Illinois, is illustrated. It is constructed

of dark brown pressed brick with wide stone trimmings, slate roof. Later a rear half will be added, duplicating the part already built.

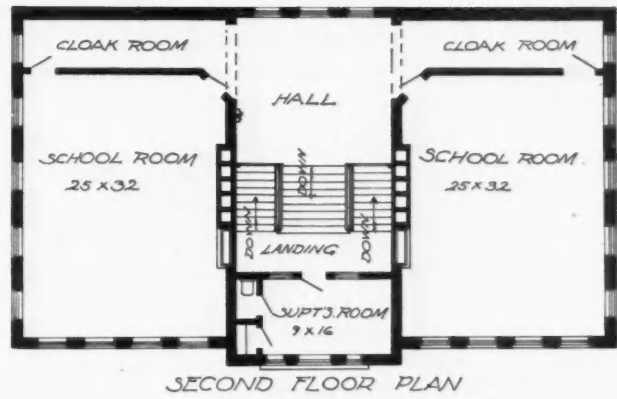
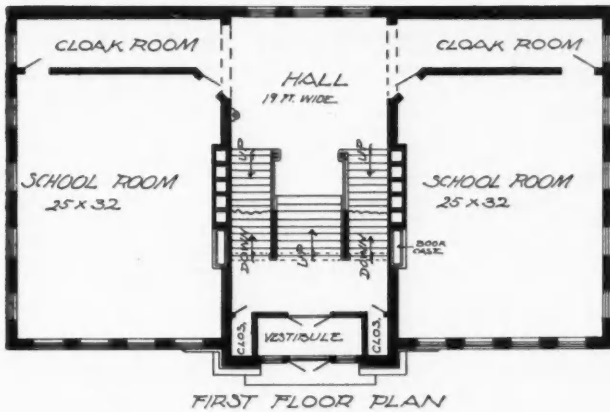

Attractive four-room school building at Burnham, Illinois. Designed by G. W. Ashby, Architect, Chicago

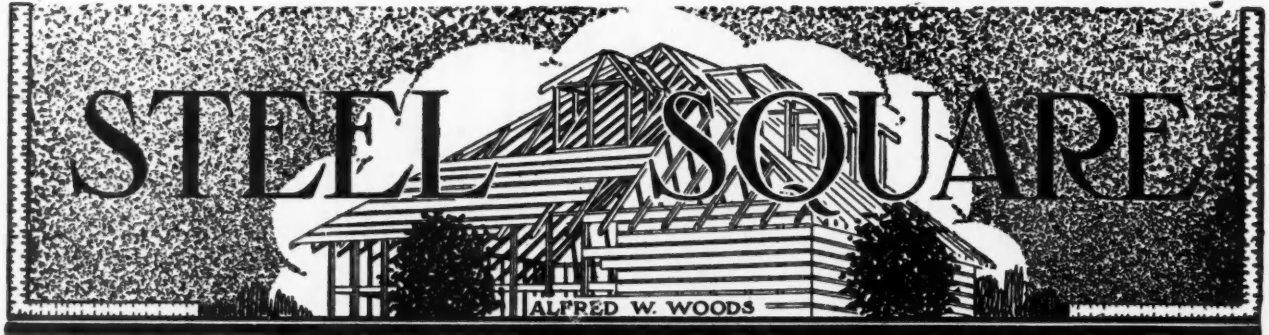

What is the Pitch of a Roof?

A COMPREHENSIVE ANALYSIS OF PITCH AS APPLIED TO THE SLOPE GIVEN THE ROOF AND HOW TO RECKON IT IN CONNECTION WITH THE STEEL SQUARE

By A. W. Woods

WE are going to take for our subject this month, pitch; everybody knows what it means, but comparatively few know how to apply it knowingly to the slope given the roof. Even among builders, there are a variety of opinions as to what designates a given slope to the roof. We once heard a knowing fellow contend that the proper way to designate pitch was to let each inch in rise to the foot run of the rafter represent a full pitch and the fractions between the inch divisions, fractions of pitch. That is, a one inch rise would be a one pitch; an inch and a quarter would be a pitch and a quarter, and so on clear up higher than roofs ever go. By this way of reckoning he claimed everybody would understand it and, consequently, nobody could go wrong on such an elevating subject.

Speaking about misunderstanding on the subject of pitch, calls to mind a case when a "city farmer" wanted a barn built on his farm. He let the job to a contractor to build it for him. Everything was planned for the arrangement and, among other things, it was to have a $1/3$ pitch. Mr. Contractor turned the work over to his foreman and he with his men went out and built the barn, and then the owner and contractor went out to take a look at it before making the final settle-

ment, but imagine their surprise to find a very low-pitched roof on it. Mr. Foreman was hastily summoned to appear on the carpet to explain why he did not follow the instructions given him. He claimed that he did as pitches go and enthusiastically went about to prove that he had furnished the real article. But he soon fell down in trying to hold up his end of the argument for, instead of taking one-third of the width of the building, he had only that much of one-half of the width of the building, hence his low roof; and he was a foreman, too, while his helpers laughed and evinced knowing winks, but said they were not foreman.

It was plainly a case of getting only half of what he thought he had, and yet his way of reckoning was not altogether at fault, either. Take it in the case of a lean-to roof, or with a building having the roof sloping one way only, then the accustomed way of reckoning from the width of the building would give the same result as his way of reckoning it, which clearly shows the rule at variance in obtaining same result.

But custom has long since decreed that the proper way of reckoning pitch, or rise which governs the pitch, is in proportion to the span of the gable having a slope each way from its topmost center. A lean-to then, technically speaking, can only be considered as half of a gable.

So far, we have not said a word about the steel square and the part it plays in solving roof pitches. So, to make good, we will finish with the square, which is a wonderful calculating instrument for finding angles for all kinds of work. In connection with the pitch, it may be readily applied as follows:

By letting 12 on the tongue represent the run for one foot, the length of the blade (24 inches) will represent the corresponding span. That being the case, the figures on the blade are to the pitch as they are to the length of the blade. Thus: 1 inch is $1/24$ pitch; 2 inches, $1/12$; 3 inches, $1/8$ pitch, and so on to the end of the blade, which, being 24 inches, is equal the span and is, therefore, one pitch. It cannot be anything else, because if there is such a thing as $1/4$,

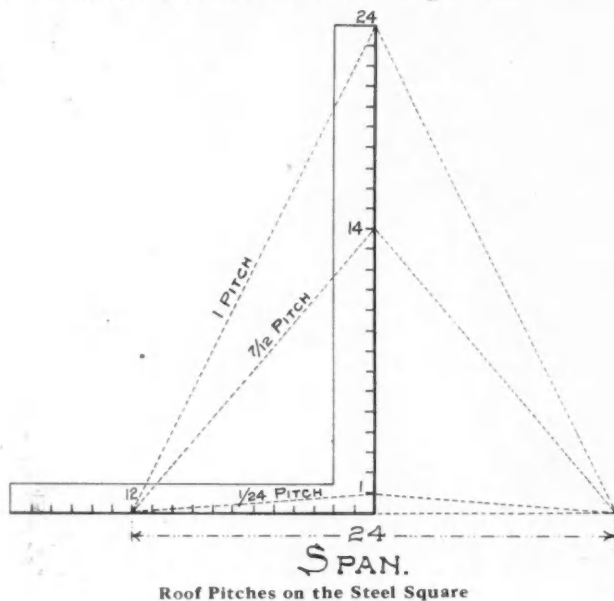

$\frac{1}{3}$, $\frac{1}{2}$, $\frac{3}{4}$, etc., pitch, it must get full somewhere along the line and, according to the reckoning of the above mentioned fractional pitches, it becomes full at the 24-inch rise to one foot.

The illustration clearly illustrates this point. Here are shown the $\frac{1}{24}$ pitch, $\frac{7}{12}$ pitch, and the one, or full pitch.

A 25-inch rise would be one and a twenty-fourth pitch; a 48 rise would be two pitches, and thus continue getting full and fuller as the rise increases, but could never become perpendicular because it would always be off 12 inches at the base; or, in other words, 12 inches out of plumb, no difference what the pitch may be. Twelve and the rise, or their ratio in all cases, will give the seat and plumb cuts for the common rafter, and 17 and the rise will give the same for the hip or valley.

We hope we have made the subject clear by presenting a simple way of mental calculation in reckoning the pitch in connection with the steel square. For instance, to find what $\frac{7}{12}$ pitch is, it may be reckoned thus: 24 divided by 12 equals 2, times 7 equals 14 inches. Therefore, a 14-inch rise is $\frac{7}{12}$ pitch.

The Steel Square QUESTION BOX

Length and Cuts for Uneven Pitches

To the Editor:

Southbridge, Mass.

Will you illustrate the method for getting the lengths of the different jack rafters on valleys or hips where the pitch is different?

I herewith enclose the plan of a roof which I am called upon to frame sometime during this winter, and when I get at it I want to do it right.

GEO. S. LABOSSIERE.

Answer: It will be noted that the span of the main roof is 28 feet 6 inches and that of the side gables are 30 feet 4 inches; thus the respective runs will be 14 feet 3 inches and 15 feet 2 inches. Nothing is said about what the pitch is and it is just as well, because it does not matter, as it can be anything desired.

The run, as mentioned, forms the basis from which to begin. Therefore, we lay off a parallelogram, using the runs for the length and width of same. This forms the area of the plan covered by the parts of the two roofs in question, as shown in Fig. 2. Drawing the diagonal line through the parallelogram will represent the run of the valley.

Now, we are ready for the pitch and so we lay off the rise, as shown for both gables, which, in this case, are of equal height. Next, we lay off the respective common rafters and in the plan we lay off the runs of the respective jacks, as shown. Now, since a jack is a part of a common rafter, by drawing lines at right angles from the individual runs at the intersecting point with the valley, to the pitch line, the common rafter will be divided into the different lengths, as required for the jacks. Here they are showing as though the jacks were laid on top of one another in their regular order. Both sides must be treated in like manner. On the other hand, if the runs had been of equal length, then only one-half of this operation would be necessary, as both sides would be alike.

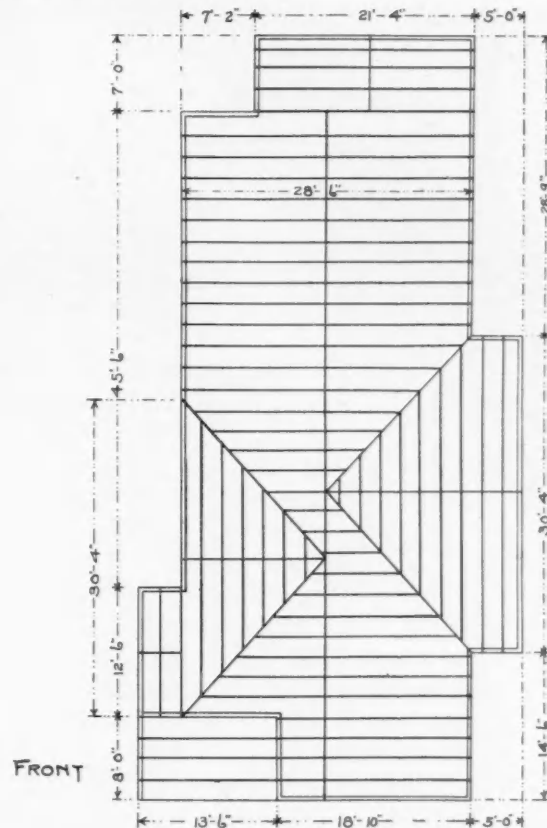

Fig. 1. Plan View of Roof

For the side cut of jack to fit against the side of the valley, take a scale on the steel square, the run of the common rafter on one gable and the length of the common rafter on the other gable; these will give the angle for the cut. The side of the square on which the length is taken, will give the cut for that side and, of course, it is understood that the run and rise taken on the square will give the seat and plumb cuts.

The tangent and length of the valley taken on the square will give the side cuts of the valley to fit in the angle formed by the ridge pieces. The side of the square on which the length is taken will give the angle.

A. W. WOODS.

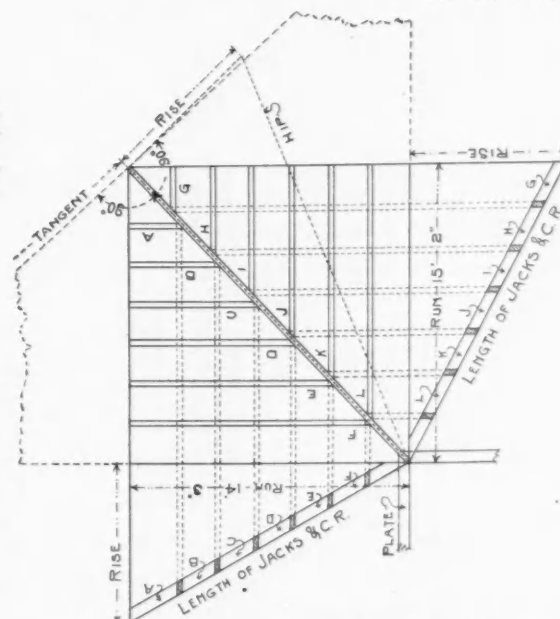

Fig. 2. Framing Diagrams for Uneven Pitches



We Discover the Great Advantage

AVAILABLE, CLEANABLE, DURABLE, ECONOMICAL—YES, ALL THESE; BUT THE "OWNER-PLEASING" POWER OF TERRA COTTA IS WHAT GETS THE MONEY

WE went through a terra cotta factory the other day; one of those factories where they make that beautiful, smooth, white terra cotta that is being used more and more as a trimming for brick buildings. The process of manufacture was complicated and very technical and most interesting; but the most interesting thing of all was the final product, the terra cotta itself. It struck us at the first glance, and the deeper we looked into it the more we were convinced that here is a building material, a trim, that every builder in the country should use.

There is no need to remind you that a pleased owner is the best advertisement that a builder has. Well, this terra cotta as a trim has got more "owner-pleasing" points about it than anything we have seen in a long time.

We are not talking now of the old-fashioned red and buff terra cotta, but of white enamel terra cotta. In the first place its smooth, white surface makes the handsomest kind of contrast to the rich reds and yellows of brickwork. Just that contrast necessary to give life and attractiveness to the appearance of any building. Then, it does not stain or weather. All the scrubbing in the world will not restore the original color to stone after it has been exposed to dust, rain and smoke. And a galvanized iron cornice must be painted every two years at least, or it rusts to pieces. Terra cotta will get dirty, of course, like anything else exposed to the weather, but all it needs is a pail of water and soap, a sponge, and a strong right arm to make it just as clean and white and new looking as the day it was put up.

Think of the blessings showered upon the builder by the neat and tidy housewife whose home is trimmed with terra cotta, who can wash the window sills, the porch rail and the door trim as easily and as often as she does the windows, thus keeping the house looking as "shining bright" outside as in—his praise will

be ever on her lips, and she will bless him.

A new and attractive building has an advertising value that must not be overlooked. Tenants are eager to get located in such buildings and will gladly pay higher rent than they would for space in an older and less attractive building. That enhanced value remains only so long as the building retains its original bright and new appearance.

A building trimmed with terra cotta stands out from among its neighbors, in the very beginning, like a day of sunshine in the middle of a week of rain. But best of all, that original brightness and freshness is permanent, without the necessity of costly painting or repairs with their attendant discomfort to the tenants. And if ever the owner decides to sell his building he will not have to look far for a purchaser.

A new building, either faced entirely or merely trimmed with terra cotta, is a tremendous stimulant to the building operations of any town or city. The success which such a building achieves rapidly spreads the building fever and creates new work and "bigger building business." And it is certainly worth while financially and every other way to point with pride at the best looking building in town and claim it as his handiwork. It means that he is going to get the order for the next building that is built with terra cotta on it, which means the next building that is built—and many more to come.

We have not yet said a thing about the detail plates which we reproduce upon the two following pages. We have placed them here because we believe they show something of the simplicity, the beauty and the wide application of terra cotta. Besides that, they are full of ideas that are useful to any man who has before him the problem of designing a good looking building.

Simplicity of design is the point toward which modern building thought is leading: Straight forceful lines, little ornament, rich and beautiful.

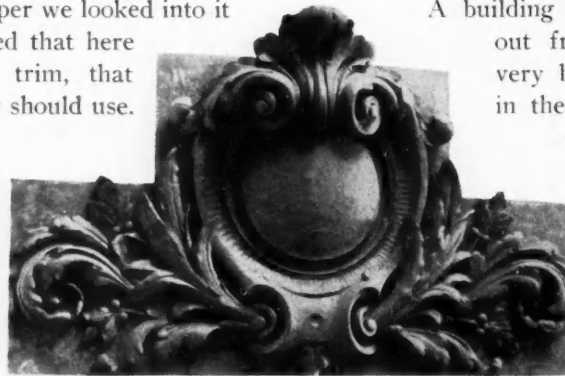

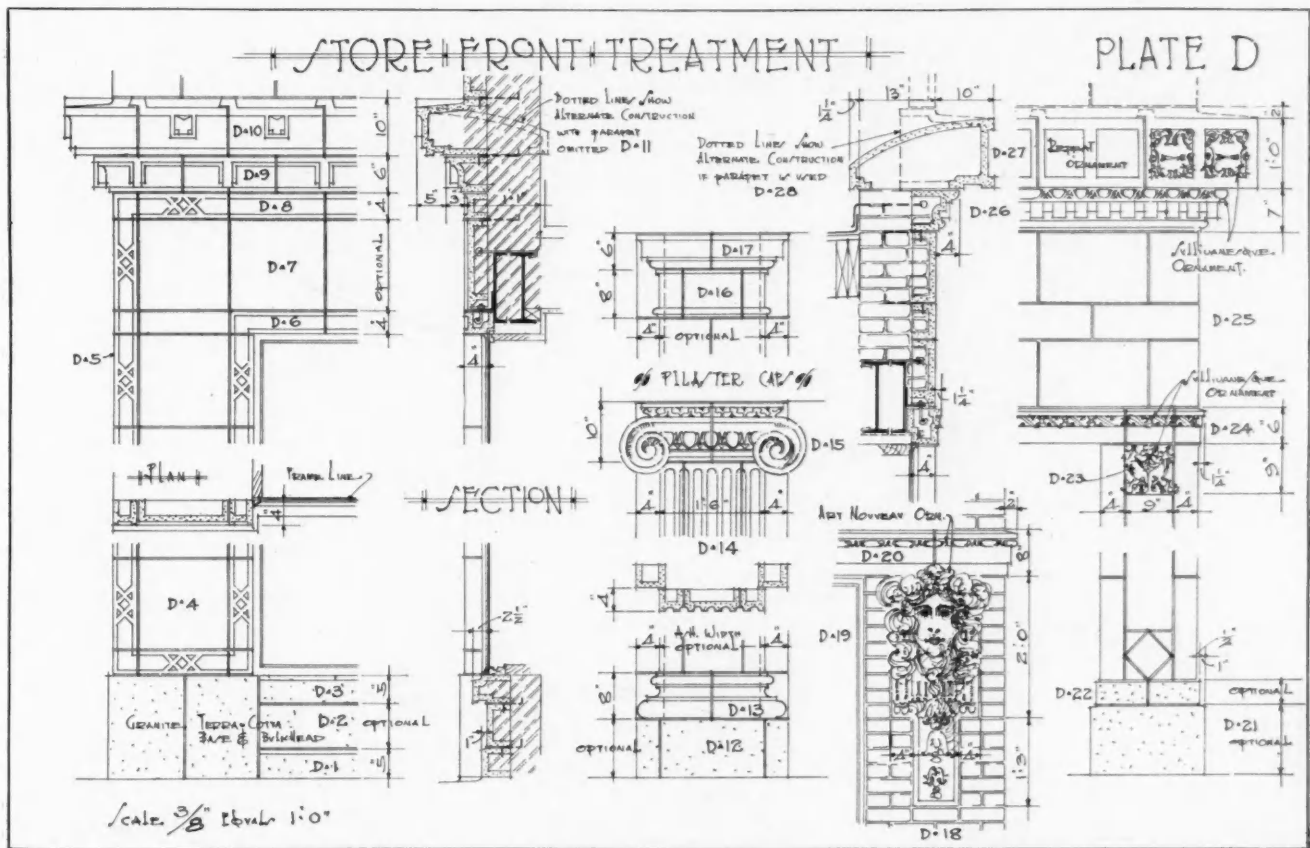
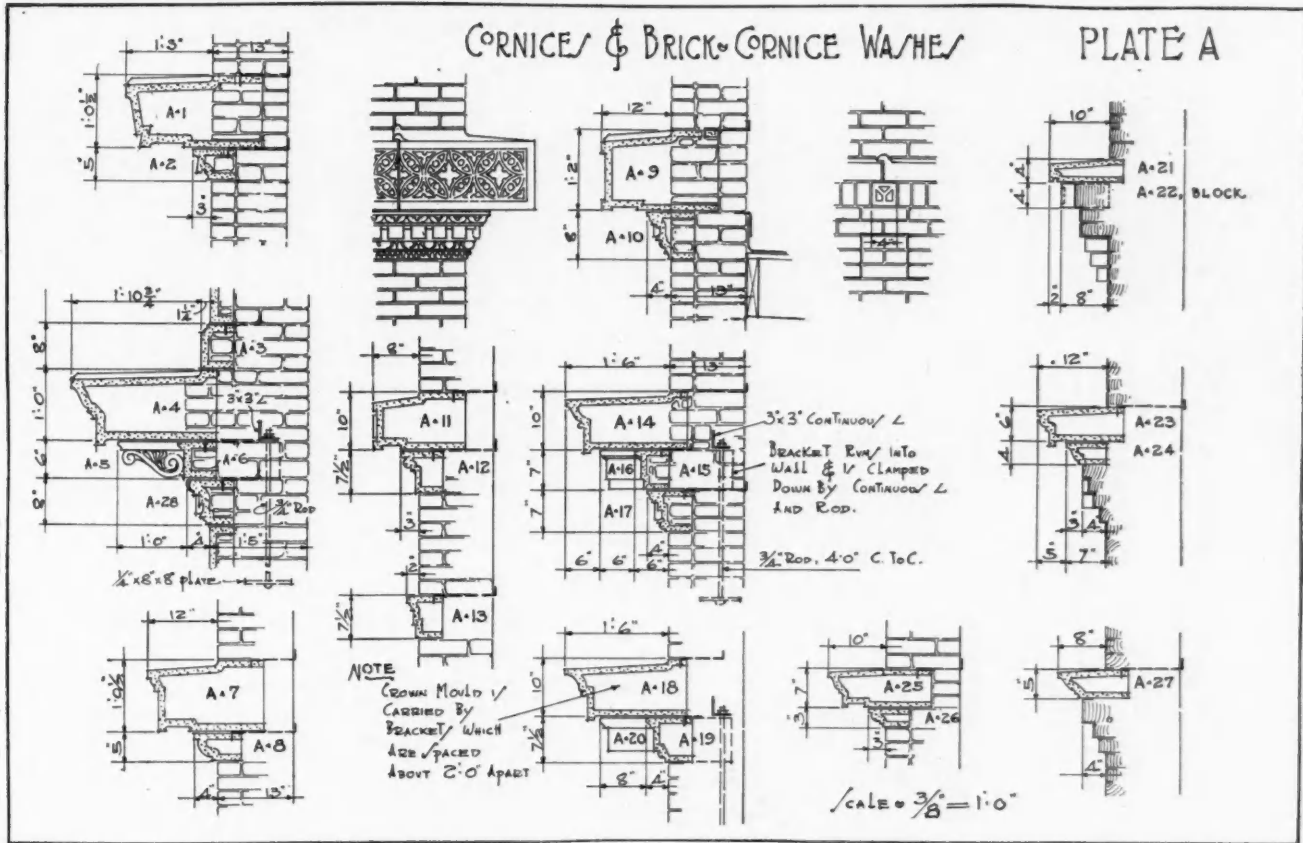

Details by courtesy of Midland Terra Cotta Company

Three-eighths inch scale drawings showing standard practice in the use of architectural terra cotta for the trim of brick buildings. These, and many other terra cotta pieces are now carried in stock for immediate delivery

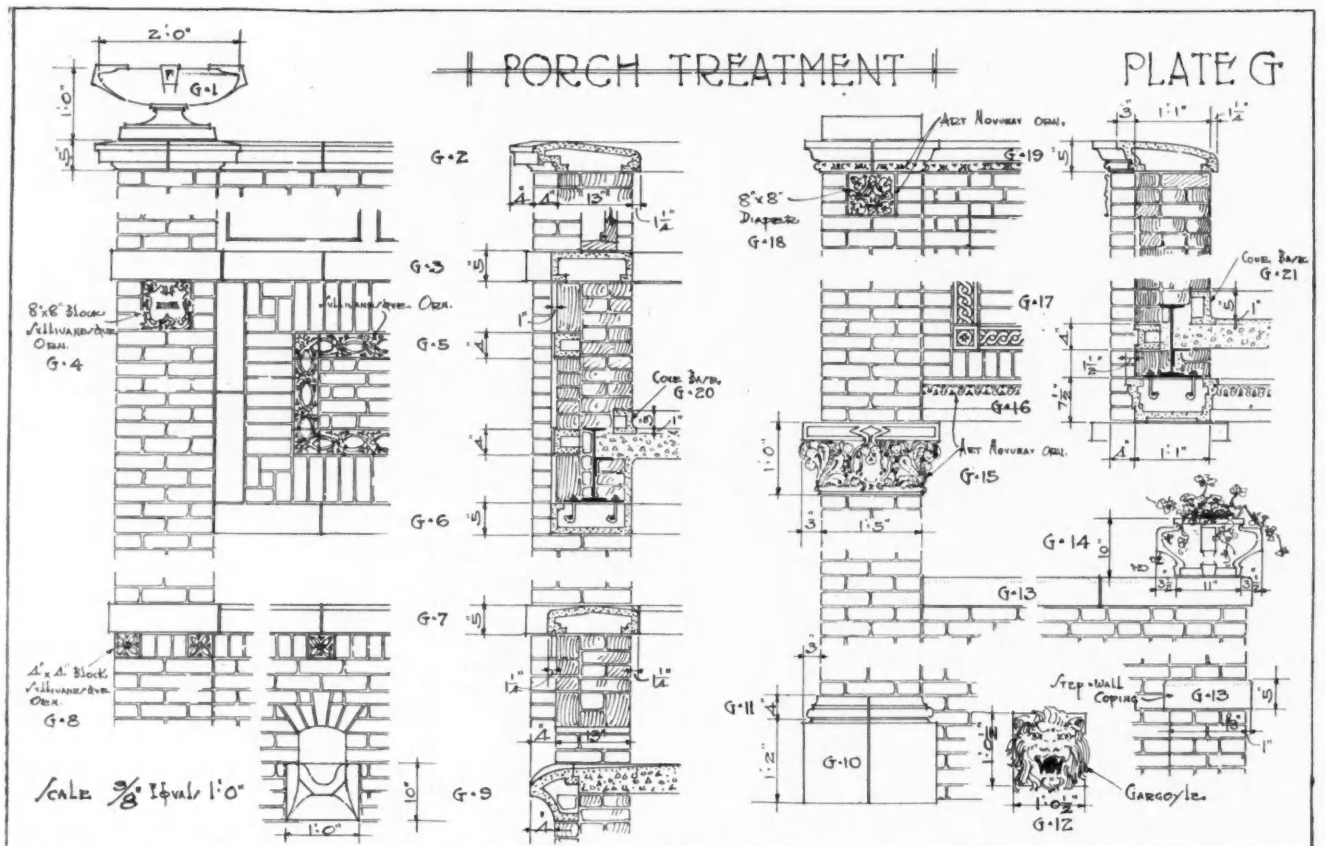
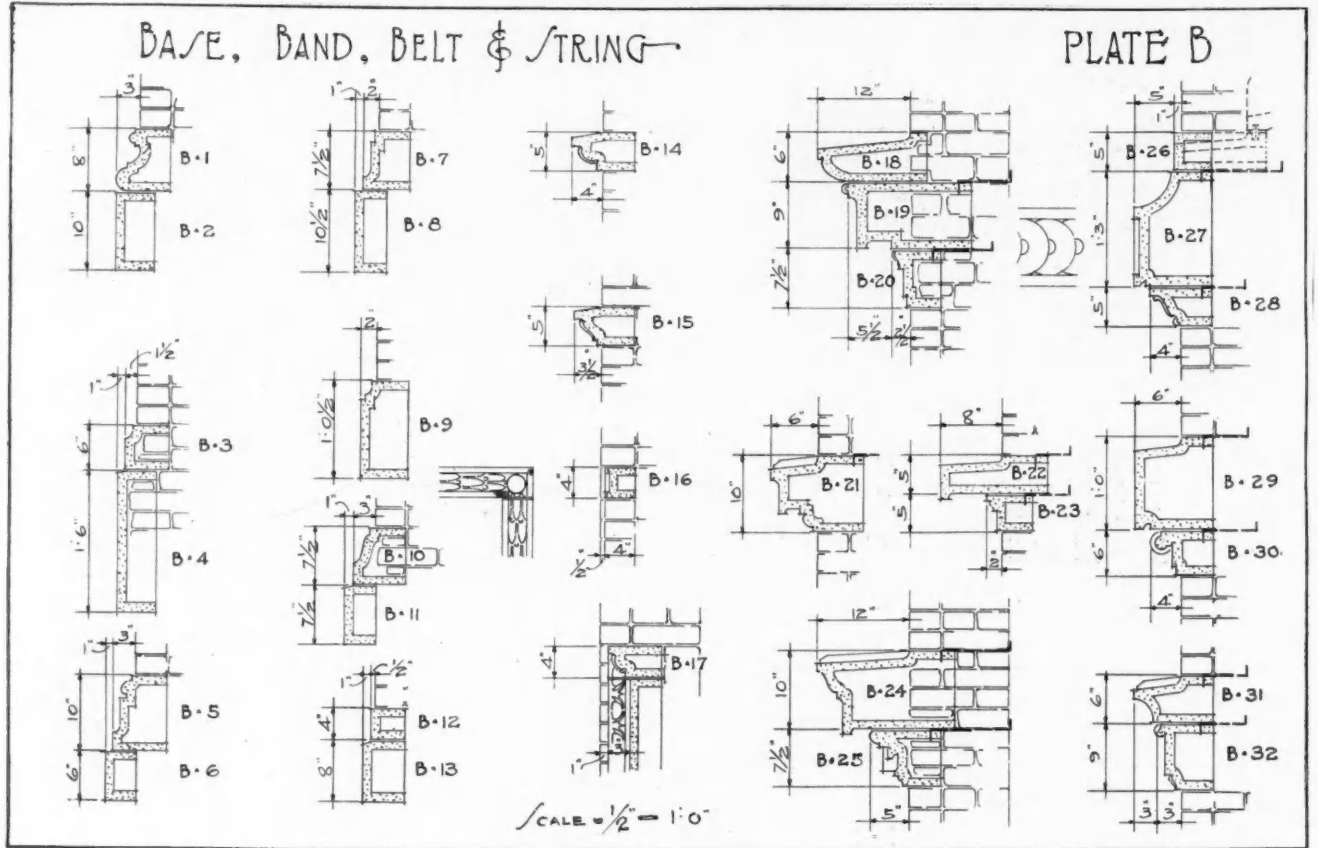

Details by courtesy of Midland Terra Cotta Company

Dimensioned details of stock terra cotta trim now much used to brighten up brick buildings. The suggestions for a two-story brick porch are interesting and suggest some of the effects easily and cheaply obtainable by using stock terra cotta



Noon Hour Talks by the Boss Carpenter

Talk No. 19-Reinforced Concrete Columns

THE BOSS TELLS ABOUT DIFFERENT METHODS OF REINFORCING CONCRETE COLUMNS, AND GIVES THE FORMULA FOR FIGURING COLUMNS WITH CENTRAL LOAD.

“NOW that the use of concrete as a building material is taking its place among the recognized forms of construction,” said the Boss, “builders are daily confronting problems involving the important consideration of strength of the material in question, when applied to the various forms of construction to which it is adapted. Since so great a part of the stability of a modern concrete building depends upon the strength and rigidity of its girders and columns, too much care cannot be used in the proper proportioning of sizes and ingredients in order to obtain safety.

“A comparison of methods of reinforcing concrete columns shows that they may be divided into the following classes:

- (a) Longitudinal reinforcement by use of steel rods.
- (b) Hooped or banded reinforcement.
- (c) A combination of these first two methods.
- (d) Structural steel members filled with concrete.

“Investigators consider, from the behavior of the concrete in tests made upon the above-named classes, that two general headings may be used to cover these four: namely,

- (1) Longitudinal reinforcement only.
- (2) Banded or hooped reinforcement.

“When the method of longitudinal reinforcement by the use of steel rods is used, the construction is of a nature similar to that shown in Fig. 49. The rods are placed near the corners for a square column, and distributed around the circumference of a circle in case of a round column. In each case they are placed at a distance in from the outside surface of the column sufficient to insure their being protected from danger of fire. A distance of 2 inches is considered ample, under ordinary conditions. It may also be well to speak at this time of the advisability of beveling or rounding all sharp corners or edges of concrete as an added protection. In order to hold these longitudinal rods firmly in place during the placing and setting of the concrete, hoops or bands of steel are placed at

intervals not farther apart than the least dimension of the column. These bands are considered by many engineers to form an additional safeguard against the buckling of the rods in the column; but Taylor and Thompson state that tests have shown that buckling would not occur when the rods were placed at least 2 inches in from the outside of the column, until the elastic limit of the steel was reached. Since this condition of loading should not be allowed, it would seem that these widely spaced bands play but little part in the actual strength of the column.

“The object of using longitudinal steel rods arranged as stated above, is to provide a resistance to secondary stresses in the column caused by an eccentric application of the applied load, or settlements which tend to change the distribution of stress in the concrete. The ratio of cross-section of steel as compared with cross-section of column within protective coating, usually varies from 1 to 2½ per cent.

“The type of reinforcement referred to under (b), and shown in one form in Fig. 50, may also be composed of riveted or welded banded or hoops joined together by light, vertical spacers, simply intended to hold reinforcement in position while placing the concrete. The object of this method is more to bind the concrete together and aid it in resisting heavy pressures than to provide reinforcement against accidental tensile stresses. Where liability of eccentric loading is to be met and the size of the column is to be kept down, a combination of this method of hooping with the longitudinal bar method would seem to give better security. The amount of reinforcement in this type is specified to be at least 1 per cent of the volume of the column enclosed. The clear spacing of the bands or hoops should not be greater than ¼ of the diameter of the enclosed column. Care must be taken in this type of column to keep the bands or coil in place during the construction of the column, in order that there may be the correct amount of protective coating, as previously stated, over the steel. Another

point in connection with this is the importance of keeping the internal core of the column straight, that all parts may be concentric in resisting pressure.

"Type of reinforcement referred to under (c) is a common type, and seems to combine good points from both (a) and (b). Figs. 51 and 52 show two examples of this type. The illustrations show for themselves the manner of combining the two methods. The object of this combination is to unite the rigidity provided by the longitudinal rods, with the toughness caused by the encircling bands or spirals. As in previous types, a protective coating

of 2 inches of concrete is provided for the exterior of the steel, and the effective area of column is considered to be that enclosed by the hooping. The amount of steel used in columns of this type varies from 1 to 4 per cent in case of the longitudinal steel, with 1 per cent or a little over for the looping. These percentages are stated in terms of volume within the protective covering of the column—that is, the volume enclosed by the spiral or hooping. One claim for this type is that the hooping holds the concrete together up to a degree of deformation which allows the steel in the longitudinal

reinforcement to be stressed up to its elastic limit. This allows a working strength larger than would be considered safe in longitudinal reinforcement alone.

"The type of column referred to as (d) may come under either one of the general headings (1) or (2). An illustration of this type is shown in Fig. 53; but this type should be kept distinct from structural steel work, which is figured to carry the load in itself, and which is merely protected from fire by the addition of a concrete coating. In this type of column, shown in Fig. 53, the interior may be figured to carry its part of the load, while the exterior is for protective purposes.

"The object of using this method of reinforcing is that a large amount of steel may be used, when desired, in a form that allows it to act as a column in itself. This method may be employed to advantage when not too great loads are to be supported while the concrete is setting. An objection which may be raised, is that the concrete is likely not to adhere as well to the flat surfaces of structural shapes as it would to smaller bars. In order that a column of this kind may have the quality of toughness and strength which characterizes the hooped type, bands or lattice should be used, of such a nature that the concrete will be well confined within the steel work. This type requires care in placing the concrete so that it may flow well around and cover all of the steel.

"If structural shapes alone are used for reinforcing purposes, they are considered in the same manner as longitudinal rods.

"Now that the methods of locating the steel used for reinforcing purposes in ordinary types have been shown," said the Boss, "it may be in place to refer to

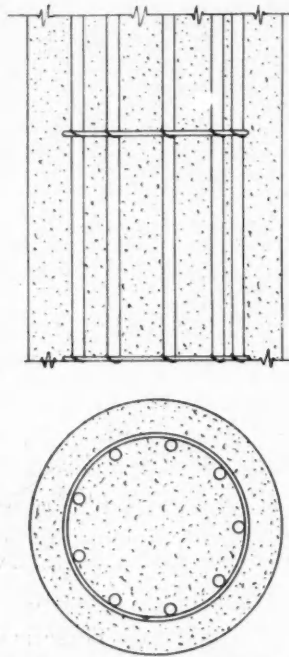

Fig. 49. Plan of Column and Elevation of Reinforcement Showing Protective Covering. Longitudinal Reinforcement Only

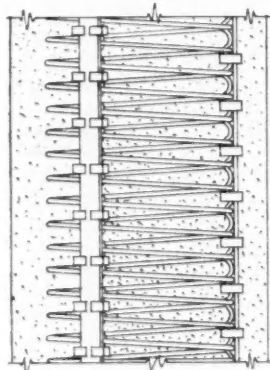

Fig. 50. Plan of Column and Elevation of Reinforcement Showing Protective Covering. Hooped or Spiral Reinforcement with Spacers Only

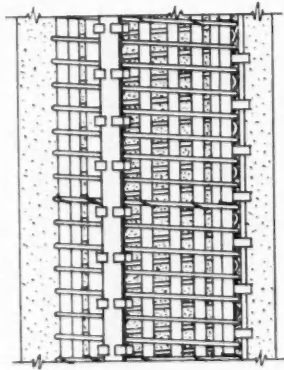

Fig. 51. Plan of Column and Elevation of Reinforcement Showing Protective Covering. Spiral Reinforcement with Longitudinal Rods

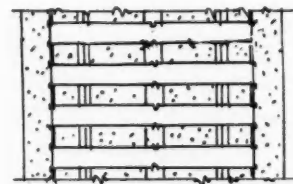

Fig. 52. Plan of Column and Elevation of Reinforcement Showing Protective Covering. Banded Reinforcement with Longitudinal Rods

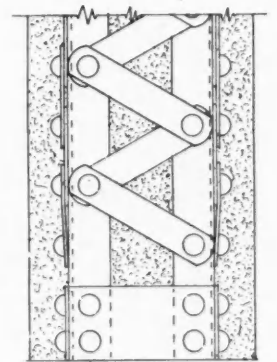

Fig. 53. Plan of Column and Elevation of Reinforcement. Structural Reinforcement

the limiting lengths of reinforced concrete columns as designated by various building codes.

"It has been noticed by investigators that the effect of the ratio of length of column to diameter or least dimension does not have much effect until a ratio of from 20 to 25 has been reached. The majority of reported tests on full-size columns are made with a ratio in the neighborhood of 10 or 12. With these ratios, what would be called a failure in actual construction occurs before side bending takes place. With a view to insuring the degree of safety indicated by results of careful tests, the following cities have restricted this ratio as follows:

Buffalo	16
Chicago	12
New York	12
Philadelphia	15
St. Louis	12
San Francisco	15

"The National Board of Fire Underwriters recommend the more conservative value of 12.

"A limiting ratio of this sort is a wise provision, since it does away with the use of slender columns, thereby lessening the danger from accidental eccentricity of load. This type of column anticipates a failure by direct compression or shear, instead of by lateral flexure."

As a measure of the dependence to be placed upon the behavior of concrete when reinforced by one of the methods described and referred to above, the Boss now wrote down the recommendations of the Joint Committee on Concrete and Reinforced Concrete, as published in the Proceedings of the American Society for Testing Materials, as follows, the relative working stresses in the concrete to be for static loads:

Type (a). Same as for concentric compression on a plain concrete column. This is 22.5 per cent of the compressive strength at 28 days, or 450 pounds per square inch, for 2,000 pounds concrete composed of 1 part Portland cement and 6 parts aggregate.

Type (b). Stresses in concrete, 20 per cent higher than those given in (a).

Type (c). When reinforced with not less than 1 per cent and not more than 4 per cent of longitudinal bars, together with bands or hoops, as previously described, stresses in concrete may be 45 per cent greater than in (a).

Type (d). When concrete core is thoroughly encased, same as in (c).

"Wherever longitudinal reinforcement is used," said the Boss, "it is figured to carry its proportion of stresses in proportion to the moduli of elasticity of the steel and concrete. This is commonly taken as 15. The hoops or bands are not to be counted upon as a direct source of strength.

"The Joint Committee recommends that where bending stresses due to eccentric loads must be provided for, the column section should be increased until the

maximum stress does not exceed those just stated.

"A common type of formula for figuring sizes of columns is found in many textbooks and is based upon united action between the steel and concrete, each one carrying its part of the stress. By observing the values for stresses in concrete as recommended by the Joint Committee, safe results should follow."

The Boss gave this formula as recommended by the Committee, which is commonly stated as follows:

$$A = \frac{P}{f_c [1 + (n-1)p]}$$

In this formula,

P = Total load to be carried by column, in pounds.

A = Area of column cross-section within boundary of protective coating, in square inches.

f = Working strength of concrete, in pounds per square inch.

n = Ratio of moduli of elasticity of steel and concrete—usually 15.

p = Ratio of cross-section of steel to A .

"In order to get total size of column," said the Boss, "the thickness of protective coating as previously referred to must be added to all sides.

"Many modifications of this formula may be used to determine other points, such as the total allowable unit-compression when the area of concrete and percentage of steel are fixed quantities, or to find the percentage of steel to use when the unit-compression on the concrete is a fixed quantity. These are given in different forms by various authors, and may be easily found.

"Where lean or inferior mixtures are used, the working strengths of the concrete must be cut down. In case a richer mixture is used, a higher working strength may be used, depending upon the compressive strength at 28 days. The Joint Committee recommend that this increase shall not exceed 25 per cent."



Advise People to Build Now

JOBS WILL BE BETTER. SLACKNESS ENABLES MILLS TO GIVE GOOD SERVICE AND MEN WORK WITH GOOD SPIRITS

"IF a person intends to build in the spring he will be acting wisely to start now instead of waiting," says Peter Lauer, a well known Milwaukee carpenter contractor and builder. "I have always urged this in good times and in bad times. With weather such as we are having now, better progress can be made than most of the time in the spring, for even when winter breaks up there is a long time that the weather is worse than it is in winter.

"A big advantage of building now is the fact that the mills are not so busy. If you go to a mill now with a plan they will get busy and tend to you, but in the spring when they are rushed they won't look at you. Another thing, men work better at this time of the year. They put more quality into their work. In spring they have spring fever and are restless.

"My advice is to start now. The result will be better work more promptly done and at less cost."

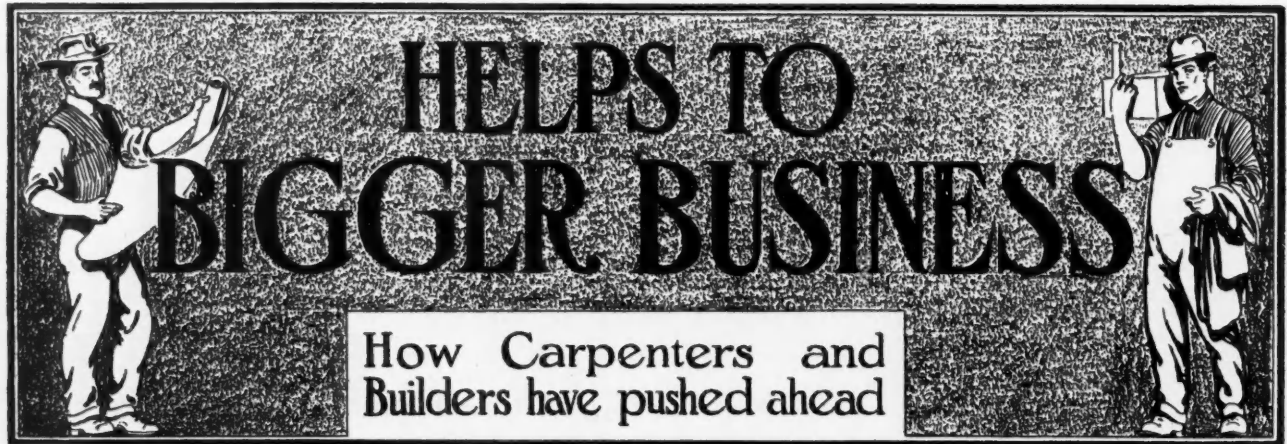

My Side Hill Shop and Its Equipment

A SUCCESSFUL BUILDER TELLS HOW HE HAS ARRANGED HIS SQUARE SHOP FOR ORDER AND EFFICIENCY—HELPFUL HINTS FOR FOOT-POWER MACHINE OWNERS

To the Editor:

Equality, Ill.

I have read with much interest the letter in correspondence column (D. B. Ross, December, 1913, issue, page 87), and as it seems from this outfit that he is in about the same boat as yours truly, I am sending a layout sketch of my own shop.

Well, yes, Mr. Ross, you certainly are *right* in liking to see everything in its place, and I want to be set down now as one of that kind myself.

Now, this sketch is self-explanatory and needs no long-winded description to take up space, but I wish to call attention to a few points of advantage, not shown in the drawings.

First, but not least, the shop is built on a hillside (sure, we have a few hillsides in southern Illinois), which, in my case, is a decided advantage. How? Well, the southwest corner is 6 inches off the ground and the northwest corner is 6 feet, and all the underpart is enclosed with vertical boxing, which not only makes the workroom much warmer in winter, but provides an excellent store house for house-moving trucks, capstan, rope, jack-screws, ladders, derricks, trestles, stock lumber, coal and all those odds and ends that you don't want in the workroom. So much for the lower room.

First, I wish to call attention to the advantages of a square

shop, as it can be seen at a glance that while my shop is not large, there is ample room for two or three men to work, making frames, or work of like nature. Note also the



Interior of Shop Looking Toward Office Corner

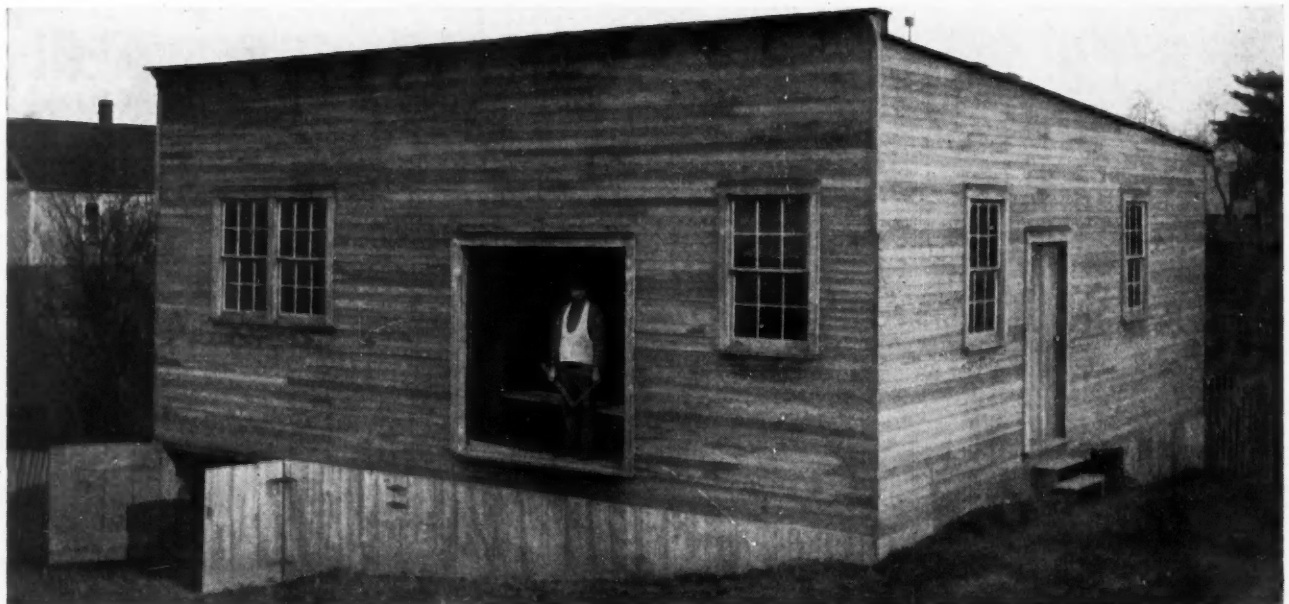

Contractor Godfrey of Equality, Ill., and his Shop—This is 32'x33', and all Contracting Gear is Safely Put Away in Space Underneath

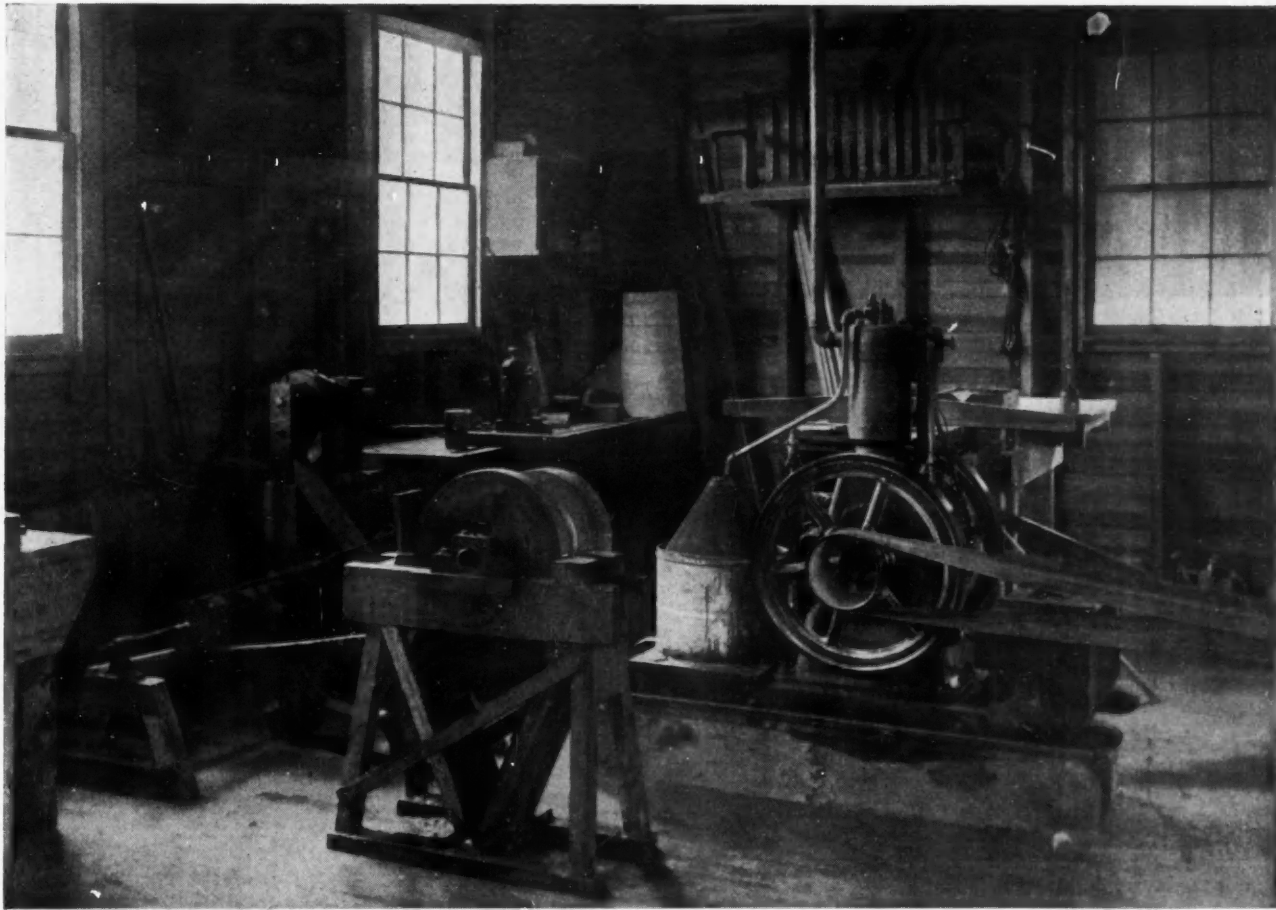

View of Engine, Power Grinder, Lathe, and Drum Sander in Godfrey's Shop

central position of the stove—well away from west front doors.

Now, Mr. Ross, as I use a Barnes No. 4, any new attachment is of interest, but it is not clear to me what part your little cut-off does, unless it is to size the screen mould in width. Is this it?

Now, for your cut-off gauge; if you have not already done

it, make a new wood bar for cut-off and turn sliding guide in front instead of behind wood bar, thereby putting board to be cut on side of wood bar next to you instead of behind it. The pieces cut off will then be ready to take from the table without having to reach over the wood bar.

I have taken treadle off my machine and run altogether by engine. I drive direct from engine to 16-inch drive pulley on countershaft, and from 16-inch pulley to 2-inch pin pulleys on saw mandrel. I bought an extra pin pulley and use two on saw mandrel and use a 3½-inch belt and hereby gain much belt power. I run my cut-off saw and Huther Brother's dado head at 3,000 r. p. m.

J. H. GODFREY,
Contractor and Builder.

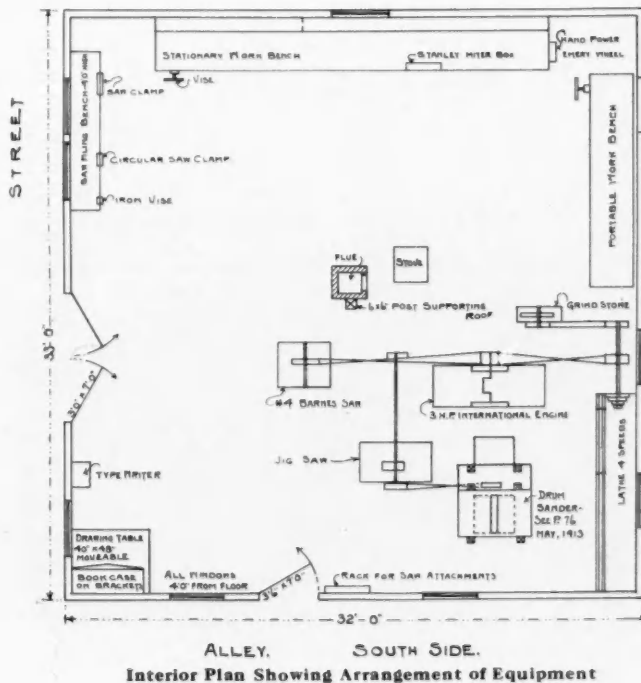

Interior Plan Showing Arrangement of Equipment

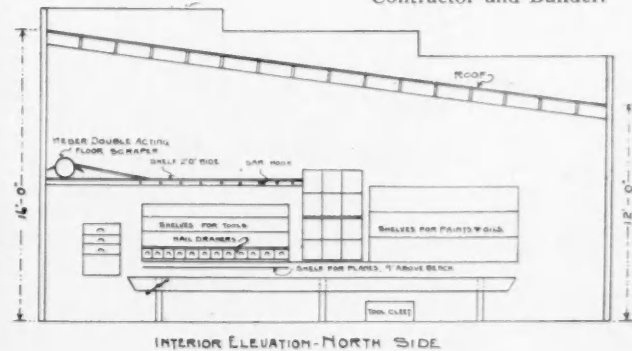

Interior Elevation View of North Wall

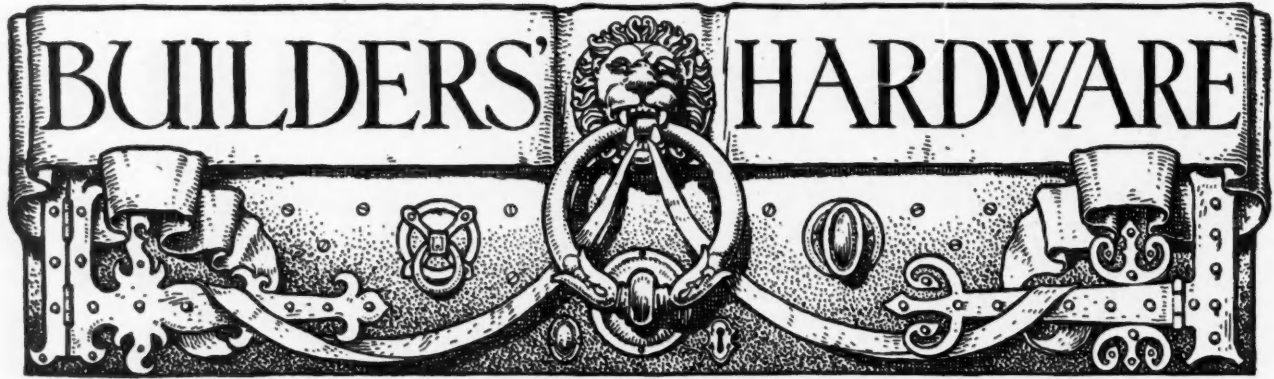

The Garage Door Problem

PART 3—ARRANGING TRACKS FOR LARGER GARAGES

By E. J. G. Phillips

Engineer with the Richards-Wilcox Mfg. Co.

Next consider private garages for one car with the main opening close to one side of the front of building as shown in Fig. 12. This type of building allows plenty of room inside for workbench, tools, etc., used in making repairs. Here there is sufficient

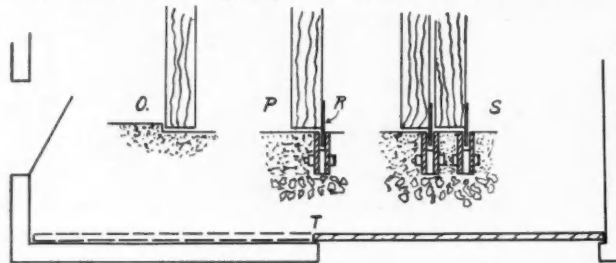

Fig. 12. Details of Storm Tight Sills

wall space to slide a single door parallel with front wall and needs no special comment. This is the simplest form of hanging doors with trolley track and if the door laps the opening from 2 inches to 4 inches we have a reasonably weatherproof job.

Wide Sliding Doors Arranged in Several Small Units

If, however, the small swing door is located in the front wall or if the wall space is too narrow to slide a single door, several other methods can be used as shown in Figs. 13 to 16. Fig. 13 shows one regular

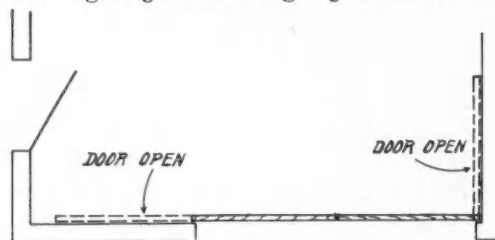

Fig. 13. Wide Door in Two Panels

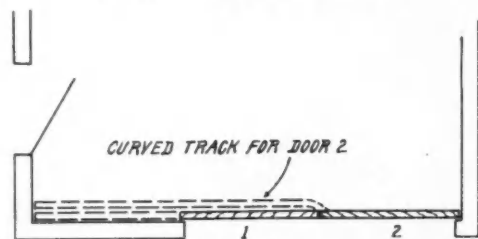

Fig. 14. Doors 1 and 2 Slide on Parallel Tracks

sliding door and one right angle door; Fig. 14 shows two doors, one of which slides in a track using a compound curve, while Fig. 15 shows two doors sliding

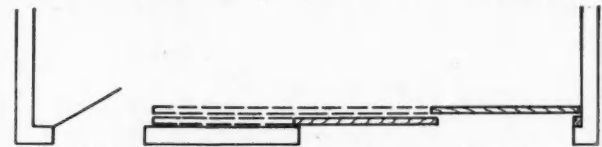

Fig. 15. Two Narrow Doors Slide Back of Partition

on parallel tracks. These methods have been fully described.

A single right angle door might be used but if there is not space enough between the car and the door to allow the large door to make the turn, the tracks can be arranged as shown in Fig. 16. A plot of clearance curves for right angle doors of various widths is given in Fig. 17. Referring again to Fig. 16, "2" is a regular right angle door and "1" runs in a curved track.

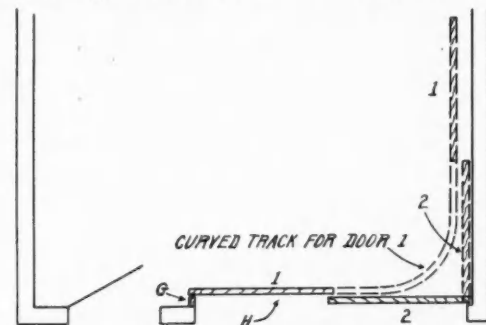

Fig. 16. Right Angle Doors Requiring Minimum Space for Turn

Door No. 1 is opened first and moved down the side-wall and No. 2 is opened afterward. The jamb "G" and the head jamb "H" in this case must also be furred out to meet the doors. The front track for door No. 2 and the entire track for door No. 1 are on the same level, while side track for door No. 2 is set above the front track as previously described for corner doors.

Sliding Doors for Two-Car Garages

A few of the larger garages designed for two or more cars will now be considered.

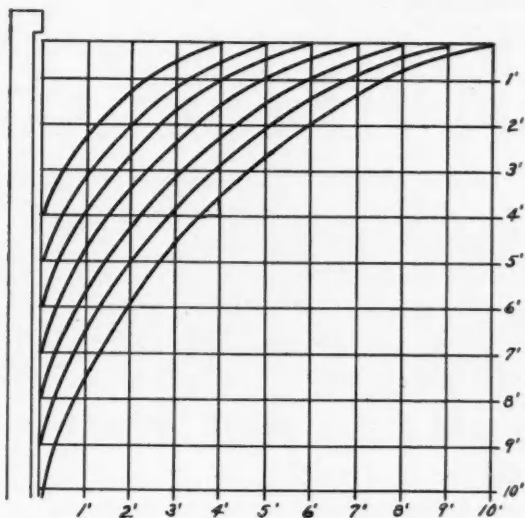

Fig. 17. Clearance Curves for Right Angle Doors of Various Widths

A garage in which the opening occupies the entire front is shown in Figs. 18 and 19. This opening may be closed in several ways; first, if it is necessary to have the entire front open at the same time, the doors may be arranged similar to those shown in Fig. 3 except, of course, that the doors will be larger. It,

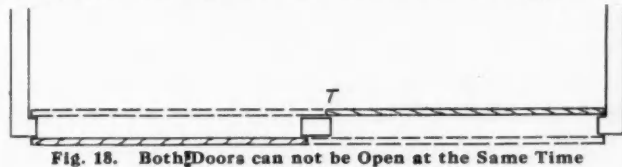

Fig. 18. Both Doors can not be Open at the Same Time

however, is seldom necessary to have the entire front clear at the same time and the arrangements shown in Figs. 18 and 19 permit the use of half the opening and are preferable because of their simplicity. Fig. 18 shows a column in the center of the opening and one door hung inside the building, one door outside. Both tracks, of course, extend entirely across the front and the doors can be moved to either side. When closed the doors lap the jambs and the column and a good tight job is secured. If there is no column in the center, the doors may be hung on parallel tracks on the inside of building, using double brackets attached to side of header to support the tracks and the same result is accomplished, see Fig. 19. On rare occasions there may not be headroom enough for the double side wall brackets and in such cases ceiling brackets may be used, attaching either to the ceiling or to the bottom of the head jamb as conditions may require. When using parallel tracks a metal weatherstrip should be used between the tracks and extending

down between the doors, to keep out the weather. This will be taken up in detail later.

In Fig. 20 is shown an opening closed by two doors on parallel tracks, which extend back along the inside wall a sufficient distance to let both doors slide back to clear the opening. In this case the track for door No. 1 nearest the wall, need only extend as far as the center of the opening, but the other track should extend entirely across the opening. The jamb at "G" is furred out to meet door No. 2 to make a tight job. In this case a wicket door is shown in door No. 2.

Fig. 21 is another example of parallel doors in which four doors are required, doors No. 1 and No. 3 running on one track and doors No. 2 and No. 4 running

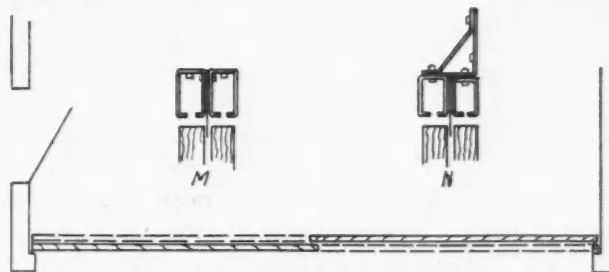

Fig. 19. No Center Column Present

in the other tracks. In this case the wall space was not wide enough to use the method shown in the previous figure. The center column should be furred out to meet doors No. 1 and No. 3, but if there should be no column, the same arrangement may yet be used, doors No. 1 and No. 3 butting together. A special locking arrangement is then required.

Fig. 22 is a modification of Fig. 14.

Next month Mr. Phillips will discuss some other arrangements of sliding Garage Doors.

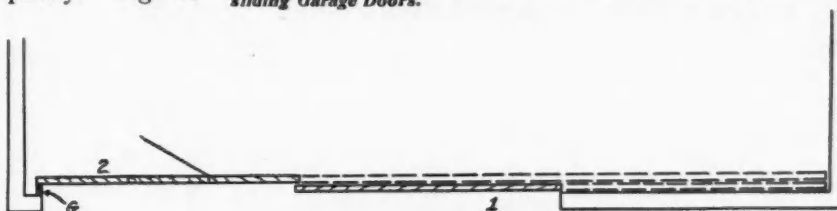

Fig. 20. Two Doors to Slide Back of Side Space

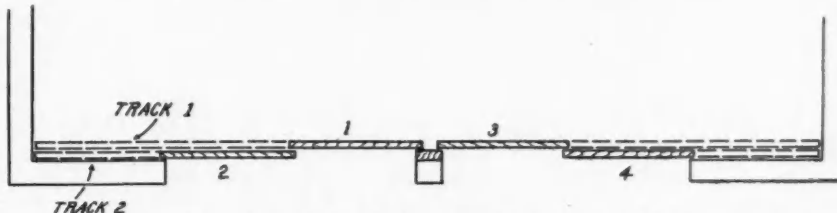

Fig. 21. Both Doors Arranged in two Panels to Slide Back of Narrow Side Space



Fig. 22. Doors Slide on Parallel Tracks, but when Open, Close Small Door



Builders Experiences in Handling Warm Air Furnace Work and Installing Steam and Hot Water Systems

Charts for Figuring Steam and Hot Water Radiation

HANDY AND DEPENDABLE SCHEME FOR QUICKLY DETERMINING AMOUNT OF RADIATOR SURFACE REQUIRED IN ANY ROOM

By Cecil F. Herington

"IN connection with the two charts for furnace heating which I gave you last month," said the Old Builder, "I have also similar ones for hot water and steam. In Fig. 1 is shown the steam heating chart and I want to point out a few differences between this chart and the furnace pipe charts.

"In the first place it will be seen that the B.t.u. loss per square foot of wall and per square foot of glass is not the same as with the furnace. In reality the radiation is the same; but 10 per cent has been allowed for window leakage which is not generally present with furnace systems. This means that the B.t.u. furnished must *not only* be those lost by the radiation of the wall and glass but must be *also* about 10 per

cent in *excess* of this amount, so as to heat the fresh air coming in around the windows and doors.

"Taking Fig. 1, which is the steam heating chart, let us see how our parlor radiation would size up when read directly from the chart with the amount of surface computed as in the June issue of the AMERICAN CARPENTER AND BUILDER.

"You will remember that this parlor had 110 square feet of wall and 30 square feet of glass facing north, while the east wall had 105 square feet and 15 square feet of glass. Taking our chart and running up the 30-square-feet-of-glass line until we get opposite the point of 110 square feet of wall, we find that we are a little beyond the diagonal line marked '20,' showing

STEAM RADIATOR SURFACE IN SQ. FT. COMMON FRAME HOUSES

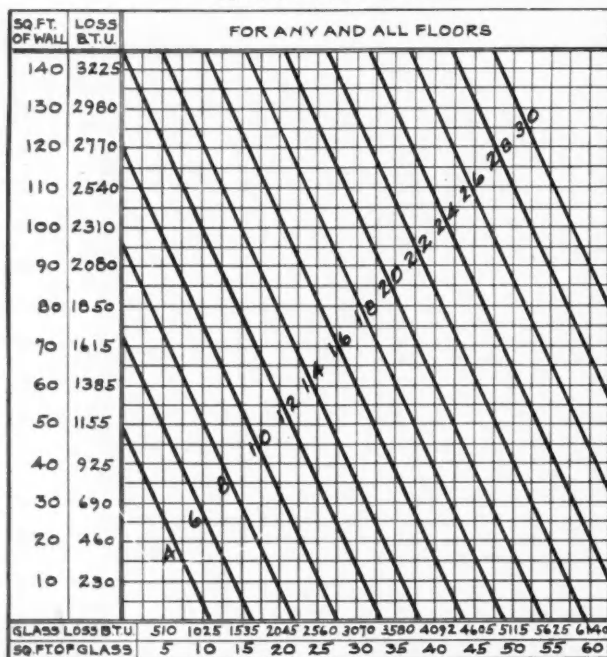

Note... The above is for good construction and S Exposure Add as follows:—medium construction 10%, poor 20%, East exposure 10%, West 20%, North 25%, Cold attic above 10%, Cold cellar beneath 10%

Fig. 1. Steam Heating Chart

HOT WATER RADIATOR SURFACE IN SQ. FT. COMMON FRAME HOUSES

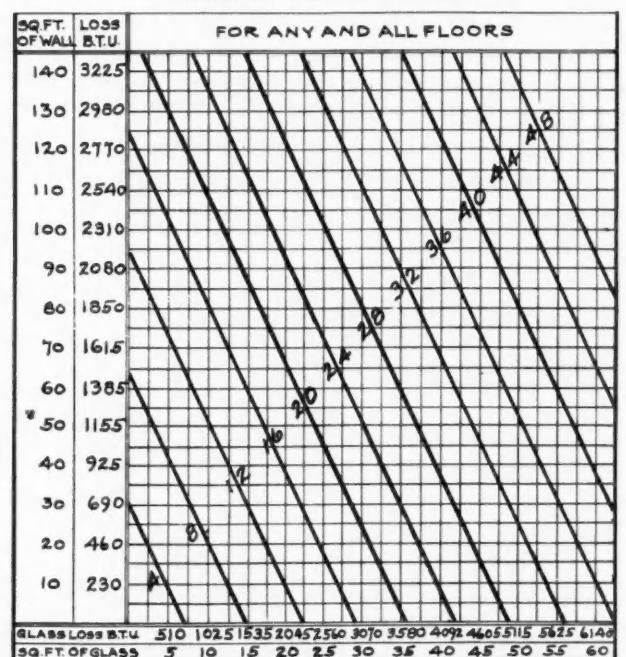

Note... The above is for good construction and S Exposure Add as follows:—medium construction 10%, poor 20%, East exposure 10%, West 20%, North 25%, Cold attic above 10%, Cold cellar beneath 10%

Fig. 2. Hot Water Heating Chart

that about 21 square feet of radiation will be required to offset the north wall heat loss, provided the room has southern exposure and is of good construction; but with northern exposure we must add 25 per cent, and for medium construction 10 per cent more, and for cold cellar below another 10 per cent, giving a total increase of 45 per cent, making our corrected amount equal to 21 plus 45 per cent of 21, or 21 plus 9, which is 30 square feet.

"For the east wall we run up the line marked 15-square-feet-of-glass, until we come opposite the point of 105 square feet of wall. We find we are past the heavy diagonal line marked '14,' showing that about 15 square feet are required to offset the east wall loss. To this must be added 10 per cent for east exposure, 10 per cent for medium construction, and 10 per cent for cold cellar, making the total increase 30 per cent. Then, 15 plus 30 per cent of 15 equals 15 plus 5, or 20 square feet. To offset the loss of both walls we add the two amounts, 30 and 20, giving a result of 50 square feet required, whereas, we previously got 51 by actual computation.

"In the upstairs bedroom we had 70 square feet of wall and 30 square feet of glass facing south, which read from the chart the same way, brings us about half way between the diagonal line '16' and '18,' showing that 17 square feet are required with the addition of 10 per cent for medium construction and another 10 per cent for cold attic, making the total addition 20 per cent, or the total radiation equal to 17 plus 4, or 21 square feet. (In our mathematical figures used in the June issue we obtained 20 square feet.)

"The hot water chart," went on the Old Builder, "is quite similar to the steam heating chart with the exception that the diagonal lines are so spaced as to show a sufficient increase in surface to take care of the hot water. This chart is used in the same way and is read for the downstairs parlor north wall by following up the 30-square-feet-of-glass line until opposite the point of 110 square feet of wall, which brings us on the 32 diagonal which must have 25 per cent added to it for northern exposure or a total of 40 square feet, while the east wall is read by following up the 15 square feet of glass line until opposite the 105-square-feet-of-wall mark, where we find that we are practically three-quarters of the way from '20' to the '24' diagonal or about 23 square feet, to which 10 per cent must be added for eastern exposure, making this total 25 square feet. The sum of the two, 40 plus 25, gives us a total of 65; with 20 per cent more to allow for medium construction and cold cellar beneath makes the final figure 77 square feet. In our mathematical calculation of hot water radiators in the August issue of the AMERICAN CARPENTER AND BUILDER we obtained 77, or exactly the same amount.

"The bedroom we previously computed had 30 square feet of glass and 70 square feet of wall, all facing south, and this read from the chart following

up the '30' line until opposite 70 is about 26 square feet which, with 20 per cent added for cold attic and medium construction, gives 31 square feet; as against 32 previously found by computation. This should demonstrate that these charts are for all practical uses exactly as accurate as when the mathematical computing is done; and a very little practice will enable any builder to tell at a glance how big a furnace pipe, how big a steam radiator or how much hot water surface he will require for any particular room."

Connecting Up Steam Generator

To the Editor:

Scotia, N. Y.

I note with interest your article on Hot Water Generators in October number of AMERICAN CARPENTER AND BUILDER. I have a Honeywell generator which is about the same as you illustrate, except I note you hook up to the flow, where mine is hooked up to return. Please advise if I am losing any advantage in the way my generator is installed.

HENRY J. HOFFMAN.

Answer: It will be noted that the cold water supply pipe is connected into the return line on one side of the boiler and the drain cock for draining the system is placed at that point. Then a branch is extended from the return to the generator and then up to the expansion tank with an altitude gauge to indicate the height of water in the tank.

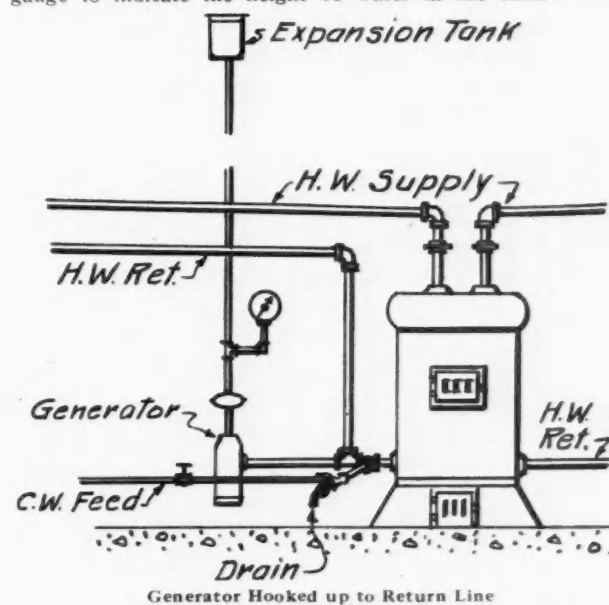

The correspondent seems to be particularly interested to know if he is losing any advantage by connecting his generator onto the return line, rather than on the flow line. Regarding this matter, his generator is installed similar to a great many others, the theory being that the action of the hot water in passing through the generator is not of a beneficial character and that the cooler return water is better. It is not thought by the writer, however, that this is of any great importance and there is the matter to be considered that the return water is much more likely to carry sediment and dirt back from the system into the boiler.

When the generator is connected to the return line this sediment is quite likely to become mixed with the mercury in the generator with undesirable results, but as far as the consumption of coal and the heat received from the radiators is concerned, there is absolutely no difference whether the generator is connected to the hot water supply line, as previously shown in my article, or to the return line, as indicated in our correspondent's sketch.

CECIL F. HERINGTON.

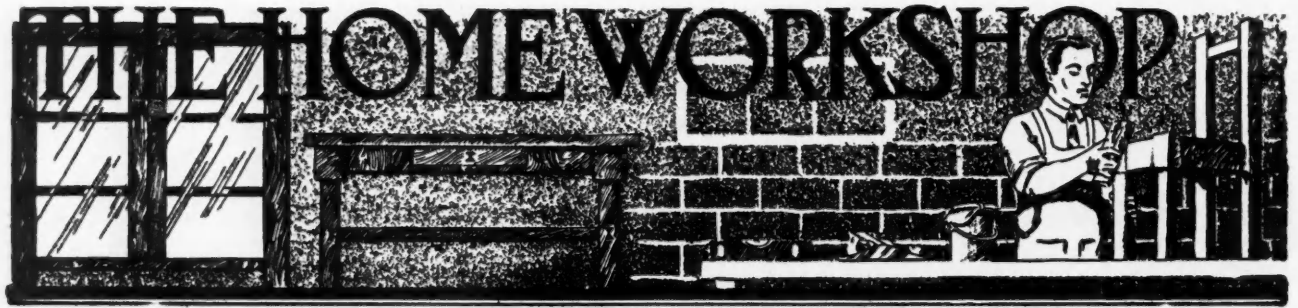

How to Make a Roman Seat

COMPLETE DIRECTIONS FOR MAKING AND FINISHING THIS SIMPLE YET INTERESTING PIECE OF HANDICRAFT WORK

By Ira S. Griffith

THE piece offered this month was made by Mr. A. J. Bonham and was intended as a seat to accompany a Mission dressing table of rather severe design. It was made of quarter-sawed oak and finished golden. The following stock is needed:

STOCK BILL FOR SEAT.

- Sides, 2 pieces, $\frac{7}{8}$ by $11\frac{1}{4}$ by $22\frac{1}{2}$ inches, S-2-S.
- Top, 1 piece, $\frac{3}{4}$ by 11 by 23 inches, S-2-S.
- Braces, 2 pieces, $\frac{3}{4}$ by $2\frac{1}{4}$ by 23 inches, S-2-S.
- Stretcher, 1 piece, $\frac{3}{4}$ by $4\frac{1}{4}$ by 27 inches, S-2-S.

The stock is specified millplaned upon two surfaces. Quarter-sawed stock will usually be found sufficiently true to warrant merely removing the mill marks by means of the cabinet scraper and sandpaper. The edges may be worked and the proper lengths secured and the ends squared in the usual manner. It should be noted that the top is somewhat narrower than the ends. This is to permit the top to be upholstered without the upholstering showing beyond the sides.

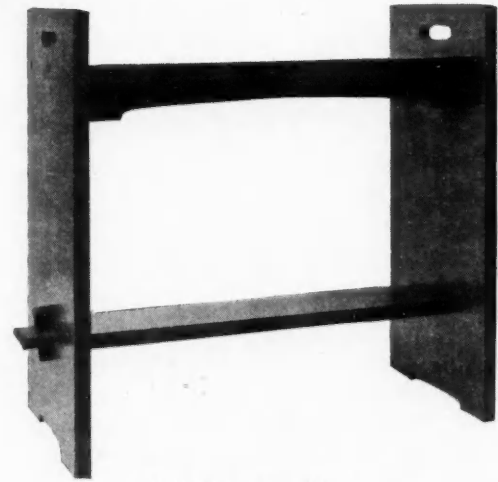

Oak Seat Completed

The top braces are housed into the sides, as are the shoulders of the tenons of the stretcher. There is nothing out of the ordinary in the construction,

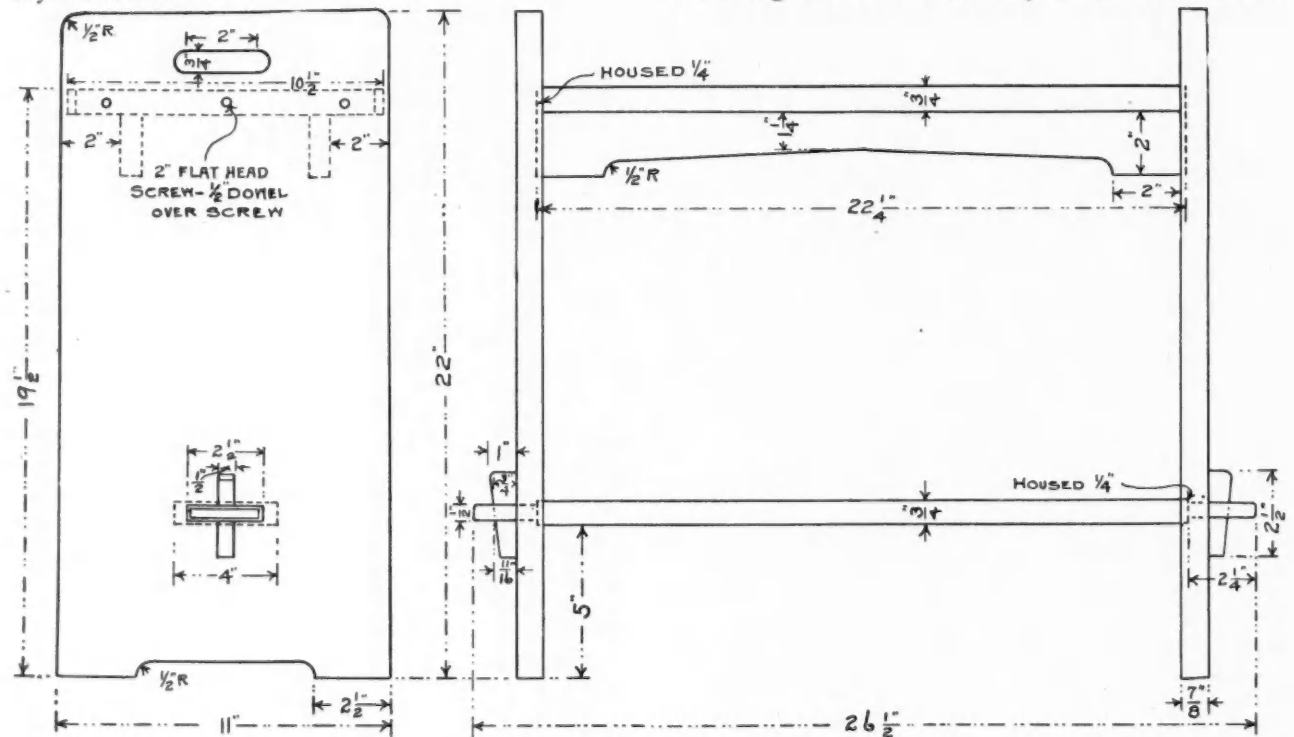

DRESSING TABLE SEAT.

and one fairly familiar with tools will have little trouble constructing the same.

By using flat-head screws and sinking them well below the surface and then covering these with wooden buttons slightly rounded, a satisfactory fastening is secured without resorting to glue.

The following finish is satisfactory for a piece of this design. Secure a box and make it air tight by pasting paper over the cracks. Place the piece under this box and within place a saucer of concentrated ammonia. Make certain that it is a strong solution; for a weak solution such as the druggist usually puts out will not act vigorously enough. Allow the fumes of the ammonia to act upon the wood over night, and in the morning a rich nut brown will be the result, the depth of color depending upon the strength of the ammonia and the length of time it is allowed to act upon the oak.

After the piece has been removed from the box, sandpaper it very lightly with number 00 paper and then give it a thin coat of shellac. Sand the shellac, when dry, and apply a paste filler colored a brown somewhat deeper than that of the stain obtained by fuming. See that the filler is well cleaned from the highlights and the corners of the frame, and then, after it has stood over night, apply another thin coat of shellac. Sand the shellac as was previously done on the other shellac coat and apply several coats of some good rubbing wax. In applying the wax, be careful not to get it on too heavily. Too much wax will result in ugly, chalk-like spottings.

The chief advantage of a fumed stain lies in its penetrating effect, hence edges are less likely to show white through wear.



Dome Lamp Stand and Lamp

To the Editor:

Tonawanda, N. Y.

About this time of year, the woodworkers' thoughts are gently turned to making of some article that may prove useful in every household and at the same time show his skill in the woodworking art.

The making of a dome lamp stand and lamp is one that should prove both useful and ornamental, for since finishing my first one, I have received enough orders without soliciting of any kind on my part, to keep me busy during my spare moments for the next six months or longer, to make some for my neighbors and friends. This means that at the end of the six months my spare time will have developed into just so much of the good long green to my credit in the bank.

One of the readers of the AMERICAN CARPENTER AND BUILDER recently complained that he could not dispose of some of his home-made furniture; to which I must agree, that it is rather hard to dispose of the more ordinary kind of goods. But let him make something out of the ordinary—something that proves almost a necessity, then make his price fair to all concerned, inviting his neighbors and friends to examine same and it will fairly keep him busy booking orders to keep him going all his spare time.

This dome stand can practically be made of any convenient wood at hand, birch, gum and white wood will finish up nicely in mahogany, white oak, chestnut, ash, quar-

tered oak, etc., will all look good in the natural or dark stains.

For making one of these dome stands I went about it as follows:

I took some chestnut, ripped same $\frac{1}{2}$ by 1 inch and cut a rabbet of $\frac{1}{4}$ by $\frac{1}{4}$ inch for the glass to fit in. Then made dome frame same as any ordinary frame $14\frac{1}{2}$ by $14\frac{1}{2}$ by 8 inches, then took cardboard and fitted a piece in each opening. Then took same to the local art glass dealer and had him cut pieces to exact size of pattern from some art glass, for which he had no particular call and which he let me have at cost price. Then went to hardware store and purchased a brass oil holder, burner and globe complete; therefore, I had my dome and lamp all ready.

Now, for making the stand. The height from floor to top is of 60 inches; the moulding around top is $\frac{1}{2}$ by $\frac{3}{4}$ inches. The post is 2 by 2 inches square, the four edges being chamfered, or left plain as desired. The cross feet are

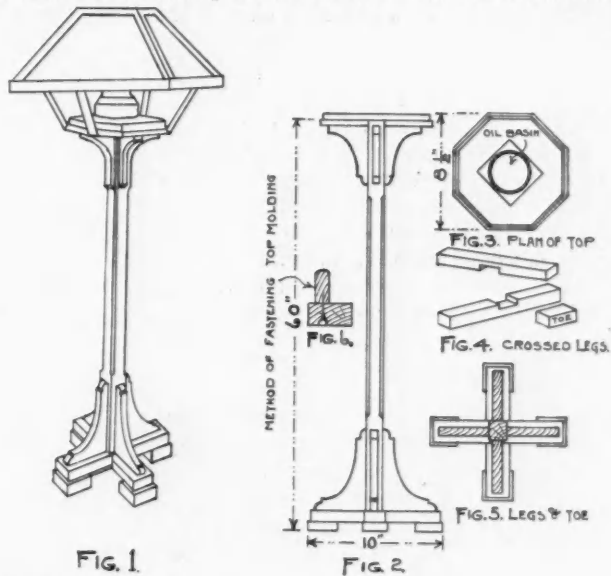

FIG. 1. GENERAL VIEW OF COMPLETED LAMP AND STAND.

FIG. 2. METHOD OF FASTENING TOP MOLDING.

FIG. 3. PLAN OF TOP.

FIG. 4. CROSSED LEGS.

FIG. 5. LEGS & TOE.

$9\frac{1}{2}$ inches long, $2\frac{1}{4}$ inches wide and 1 inch thick; the square toes are $2\frac{3}{4}$ by $2\frac{3}{4}$ inches by 1 inch or $1\frac{1}{4}$ inches thick, as desired. They are glued to the underside of the feet with a projection of $\frac{1}{4}$ inch in front and sides, as shown in sketch. As the lower brackets are glued, or screwed to the cross pieces, the toes should not be fixed until brackets are in place. The lower brackets are 6 inches long, $3\frac{3}{4}$ inches wide and 1 inch thick. The brackets are doweled and glued to the post; they are glued to the feet with screws countersunk into each from below. The upper brackets are 4 inches long, 3 inches wide and $\frac{3}{4}$ or $\frac{7}{8}$ inches thick; brackets are doweled and glued to the post, also to underside of top.

The top (Fig 3) $\frac{1}{2}$ or $\frac{5}{8}$ inches thick, may be made octagonal or square, as desired, and 8 or 9 inches across. The underside is bored for short dowels to secure it to post and brackets, or a sub top may first be used of $\frac{3}{8}$ inch and the original top of $\frac{3}{8}$ or $\frac{1}{2}$ inch, although this is not essential.

RICHARD O. NEWBECKER.



Forest Notes

There are about 37 pines native to the United States, of which 25 are western species, and 12 eastern.

Paraguay has valuable forest resources, the most important of which is quebracho, particularly rich in tannin.

CORRESPONDENCE



Questions Answered and Ideas Exchanged.

Our Readers are Requested and Urged to Make Free Use of These Columns for the Discussion of all Questions of Interest to Carpenters and Builders

He Doesn't Care for the Forestry Dept.

To the Editor:

St. Ignatius, Mont.

Your magazine is well worth having at any time and I consider it a good thing to peruse with profit any evening.

I cannot refrain from saying that if your "Forest Notes," such as have appeared in the last few issues are inspired by that gang of white sepulchers who call themselves conservationists, you should, in justice to your clientele of builders (victims of the "con" in all this conservation), suppress this nonsensical rot, and turn the searchlight of accurate inquiry onto this farcical forest service at the source, here in the West. I gasp for words.

V. A. McCORMACK,

Builder.

large factory to work on, I couldn't get along without mine.

I am sending also a photo of Peter Nelson's round barn, which I built last summer. It is my own design. It would make any dairy farmer proud to own one like it.

JOHN SOLIN, JR.



How Many Agree with This?

To the Editor:

Riverside, Iowa.

The November number of the AMERICAN CARPENTER AND BUILDER at hand and read from front to back, and was filed away; and I was busy with another journal, grew tired of it, laid it aside, and went to my files; got the A. C. & B. and again was looking over its valuable pages when I came across the census sheet; tore it out and am mailing it to you. I have endeavored to answer it in detail, as my thoughts dictated to my pen.

I am glad to inform you I am well pleased with the AMERICAN CARPENTER AND BUILDER, so much so I have filed all my copies away since January, 1908, and I have them where I can get at them whenever I want them.



Gets Over North Country on Motorcycle

To the Editor: Balsam Lake, Wis.

As I have not contributed anything towards your valuable paper, I feel it my duty to represent this neck of the woods, as I have not seen anything from here—to let the outer world know that there are living people this far North.

Am sending a picture of myself and traveling gear. Don't ask me what a carpenter can do with a motorcycle! As my work is in the country and have a

John Solin Jr., His Trusty Steed and One of His Big Round Barns at Balsam Lake, Wis.

There is nothing dull in them at all to a practical man from a business standpoint. I have had it told me it was no good; but I have watched that same mechanic, and he is in the same old rut he was twenty years ago—no better mechanic, and does things in a way it "us" to be did."

But, brothers and fellow workers, at this day and age of the world such is not what the building public demands. The demands of today are for good houses, and business houses, and not for merely houses and would-be business houses. I have found out, by my own experiences, that a mechanic of today must be up with the times; not just merely telling what he can do, but must produce the goods to prove his assertion.

He, too, must talk quality, not quantity. Coupled with this, he must be honest and do honest work. He must read and study, and study to know he is right. When he accomplishes that, then his success is assured; his patrons then have confidence in him, and there are no idle moments for such a builder.

O. B. OVERHOLSER,
General Contractor and Builder.



Thinks Licensing Builders Would Hurt

To the Editor: Toronto, Canada.

In the course of my perusal of my January issue I note reference of B. C. Graves to former correspondence from J. L. Brooks, regarding licensing builders.

Though the instances he cites of faulty construction would justify serious measures, I doubt if the method proposed would drive such slip shod work out of our line. No man could rightly claim common sense and justify such work at the same time. My opinion is that no system can be framed to eliminate fraudulent practice in this or almost any other business, and such I take it, were the instances referred to.

The two great countries on this continent are lauded loud and long as "Lands of the Free," yet every day brings suggestions from some to tie people down to certain rules, or have some one appointed to see that each does what he should. The consequence is that in our cities especially, we have so many by-laws and "bum" laws to dodge that it almost keeps one busy dodging without doing anything else.

Why not rather seek some method to encourage honorable practice among our craft which in itself would tend largely to shame out such skin flints? An honorable man is seldom out of demand in any line of work, and a dishonorable man is almost sure to run himself out. I realize, of course, that some can grease their way through with their poor work, while a good workman is often put to unnecessary inconvenience; but this, I believe, is due to tact—another evidence of character.

The licensing system could hardly be expected to eliminate the "sharks" from the trades as they would likely be the first ones to grease their way up.

I enclose herewith (not suitable to reprint in a family Journal. Ed.), some clippings from a Toronto paper, in regard to an investigation of our local City Architect's Department, which will tend to show the rottenness of the watch-dog system of controlling the building trade.

Because of these conditions I have transferred my operation to fields where I am free to do a good job without having to take dictation from anyone who possibly knows no more than I. Not only do I resent these conditions but my experience with the Department some time ago convinced me that I was tabled for trouble (possibly because I drew and submitted my own plans for a pair of houses, in the face of a request from one of the officials for the job).

However, I find building operations are not confined to territory covered by their supervision. Hence, I've left them to have the trouble, and I'm doing nicely elsewhere.

GEO. H. JACKSON.

He Kicks on Fireplace

To the Editor: Wilmington, Cal.
This being Christmas, while I am sitting around scratching my shins, I picked up the July number of your valued paper, and on page 80 I found details of a fireplace, like Sketch No. 1. Now, I am an old rooster of a good deal of experience and

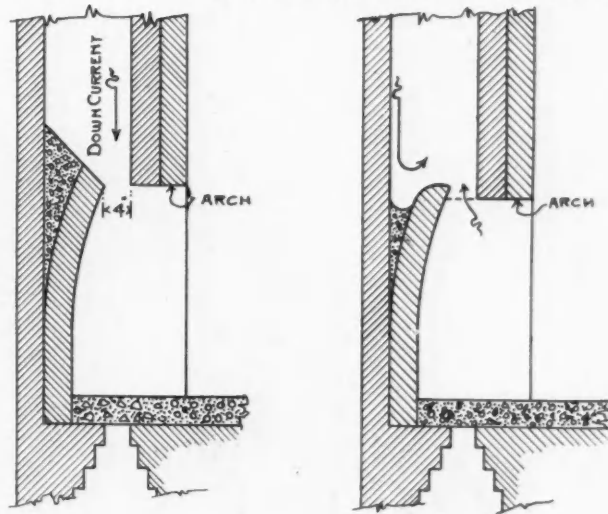

FIG. 1.

FIG. 2.

have found the hollow back wall, shown in Fig. 2, to be far superior to the one you detail, as it has a tendency to check a down current, or gust coming down the chimney, whereas the other scoots everything before it down into the room. Note the back should extend also a little above the arch, too, instead of coming even with it, as in No. 1, and in practice sometimes a little below.

With best wishes for a Happy New Year, I am,
L. M. HODGE.



Another Form of Threshold

To the Editor: Lane, Kans.

I see two answers to Jack Leg's inquiry for a threshold to keep the water out, but do not think either of them amount to much. I enclose cross-sectional drawing of threshold that will come nearer keeping out the water for an all-wood threshold that I know of.

The groove should be 3/8 or 1/2 inch wide, 1/2 inch deep in middle of threshold and out to nothing at the ends, so the water will all run to the center, where there should be two

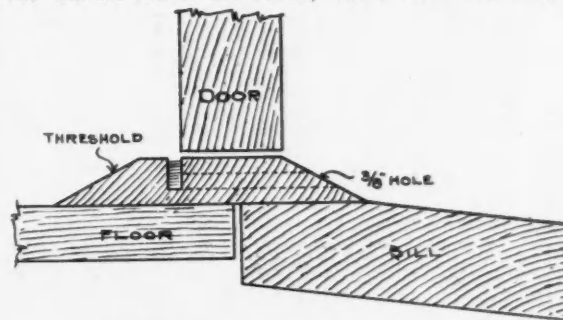

Cross Section of Storm Proof Threshold

3/8-inch holes bored from the outside edge of threshold and connecting with the groove about 1 inch on either side of the center of threshold. Wind drives the water under the door and it drips off of the inner edge of door; the groove catches it and it runs out through the holes.

If any one has anything better, would like to see it in the AMERICAN CARPENTER AND BUILDER.

J. P. WELLS,
Carpenter and Builder.

His First Round Barn

To the Editor:

Orland, Ind.

My first attempt at building a round barn was this past season. You see the results in the pictures. I corresponded with several contractors but was advised not to try to build the roof I had my mind. But I had it so completely worked out that I undertook the job; and neither the owner nor myself have been sorry for it.

The barn is 60 feet in diameter, and has a 14 by 56-foot silo in the center. The barn measures 65 feet from basement to cupola roof. I used 2 by 6-inch for studding. The sill for the barn I made out of 1 by 5-inch, using five pieces; the same for the plate. The circle next to the silo was made out of $\frac{1}{2}$ by 8-inch, using ten thicknesses.

My rafters I made out of 1 by 3-inch, six thicknesses; these are 41 feet long. As I had a 12-foot opening at the top that gave me room enough to get all my rafters in place. The

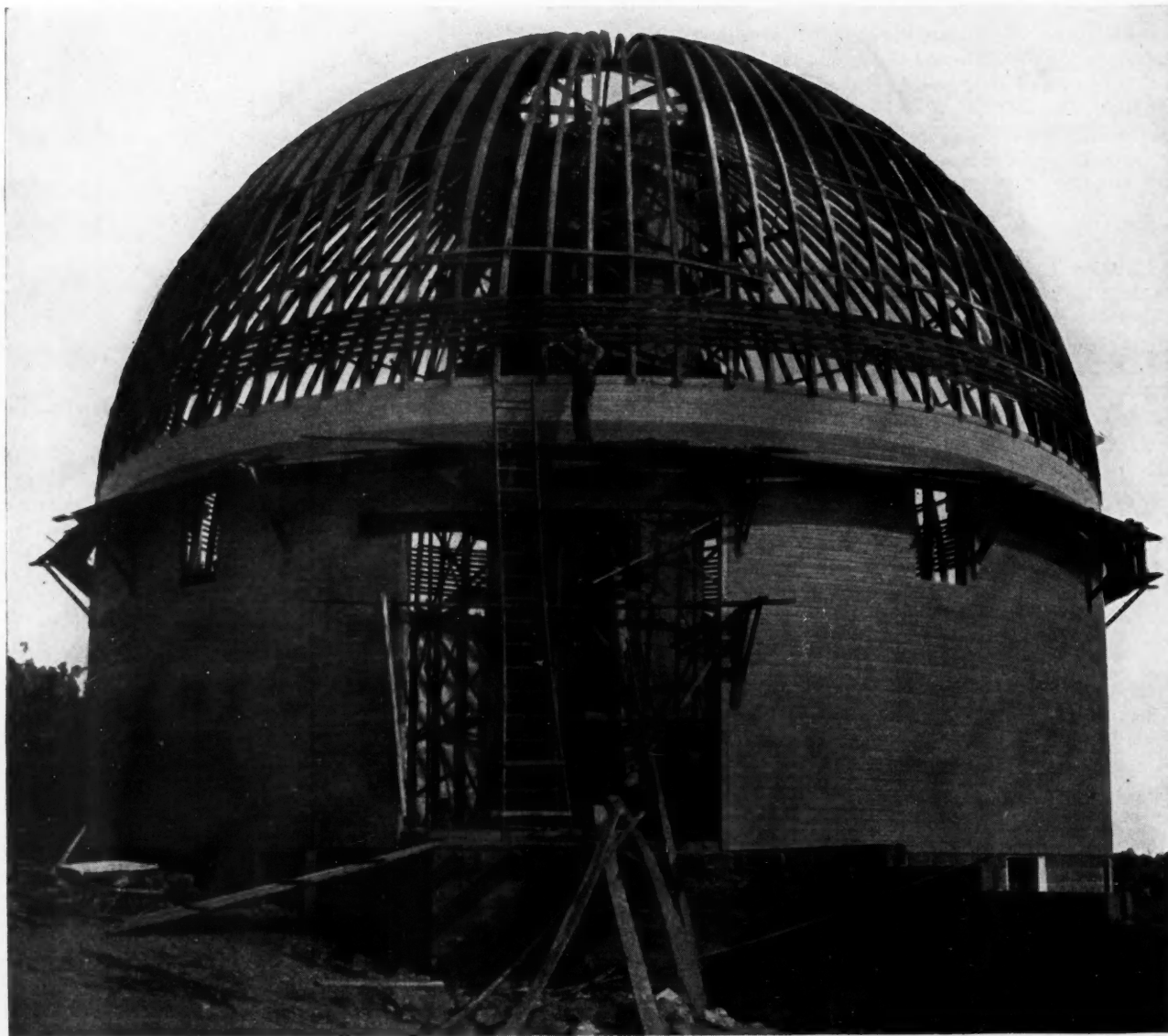

Barn 60 Ft. in Diameter, Photo Taken During Construction. Note Silo in Center, also Curved Rafters



Foundation is Cement Blocks—Round Barn Built by O. H. Bordner, Orland, Ind.

rafters are 2 feet apart at bottom, 1 inch at top. The studing in the cupola are 6 feet long. The openings in the cupola are screened with sand screen.

Now, as to the basement, there is an 8-foot feed alley around the silo; then comes the mangers and feed troughs. That leaves room enough where the cattle are, to drive around with a hay rack on the wagon, if need be. There is a hay, silage and grain chute above the alley.

There is room for forty cows. The driveway into the barn is cemented; then there is a milk room under it, where

there is a well, a cream separator, a gasoline engine, and plenty of room to handle the milk and cream.

There are 53,000 shingles on the roof and a little over a ton of nails in the barn. I am sending you a picture of the foundation—concrete blocks.

Now, if there are any questions about this I will try to answer them.

O. H. BORDNER.



Asks About Building Lines

To the Editor: New Brighton, N. Y.

I would like to learn from your readers in various parts of the country how builders set their fences and buildings in relation to the land surveyors' line.

Does he set the posts, rail, or pickets to the line along the highway?

Does he set the middle of a wall or fence to the party line?

What part of a frame or masonry building is set to line along the highway?

Why should a party wall or fence encroach upon his neighbor's premises, as some surveyors contend? Why should the trimmings on a building encroach upon the highway?

This is a much mooted question among surveyors. It may not seem important in a country district, but when it grows into a city and property becomes more valuable, possession of inches are then disputed among neighbors and objected to by the "City Authorities," as we recently experienced in New York City.

MARTIN BERNHARDT.

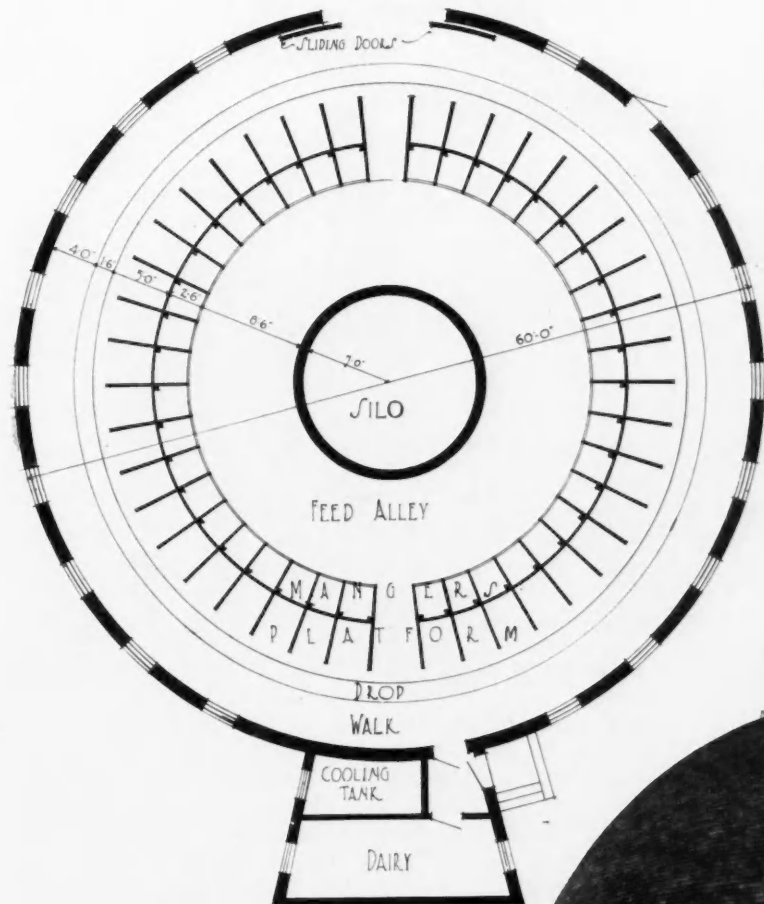

Plans of Basement Floor

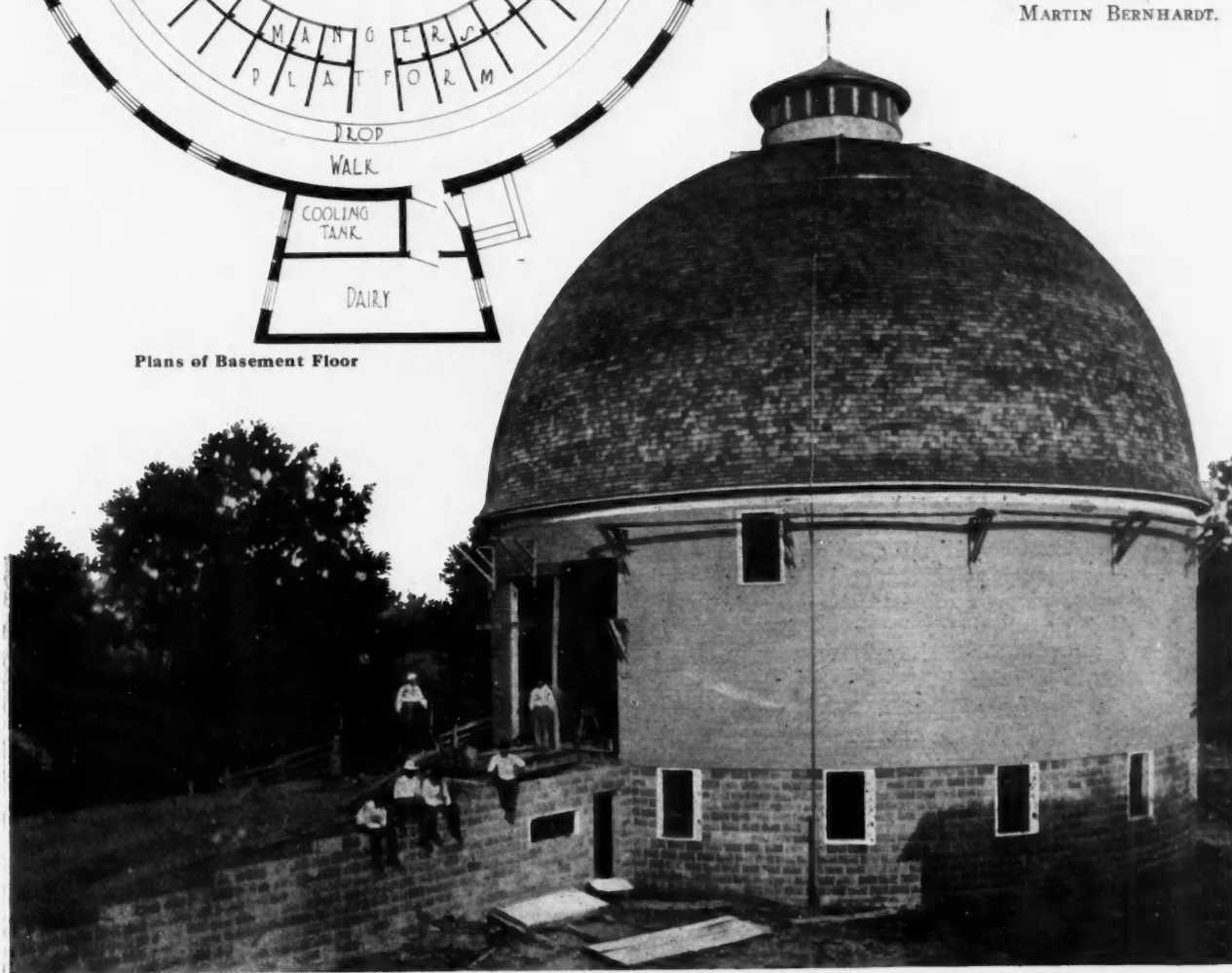

Sixty-Foot Round Barn, Nearly Completed. Cows are Stabled in the Basement and Milk Room is Arranged Under Driveway to First Floor

Makes Fine Mahogany Furniture

To the Editor: Montague, Mich.
I wish to compliment the Editors of the AMERICAN CARPENTER AND BUILDER for their generous interest in the "Big Family." It surely is an incentive to the best that we may do. Here are a number of fine furniture pieces I have made. As the wood is mahogany, I drew my designs full size and cut them out, to economize in cutting up my lumber.

Figure 1 is a plan of taboret. It shows joints mitred and

side across the grain to prevent its warping or splitting. The pedestal and table are glued-up stock, and the main joints in the Roman stool (from which cushion is removed) are mortise and tenon.

Having some Tobey (Chicago) hand-made mahogany furniture that has been made about fifteen years, I wished to match it as near as may be, so I took a dry-goods box of proper size and lined it with about three thicknesses of paper, breaking joints, and made the top tight, and after stock was ready for the filler, I put it in the box and "finished" with as



Beautiful Mahogany Furniture Made by E. L. Hubert, Montague, Mich.

plowed for slip tongue. This adds to the strength of the joint and keeps it in position when gluing up.

At the center and bottom of the legs clamps were used. From strips I nailed up two little frames for top end, to receive three sides each.

While the figure is self-explanatory, I found these advantages: With a helper I could glue the two joints, insert the tongues, place in frame, drive the four wedges, and it was in position for the clamps, which were turned down before the glue got cold.

When the two halves were dry, the brace (a) was removed from each frame and the two were fastened as dotted lines indicate, when the last two joints were set up without any strain on the others and every joint was tight.

Figure 2 shows the manner of fastening legs to plant stand. The top has a piece of wood glued on the bottom

high gravity ammonia as I could procure locally, by placing saucers of it in the bottom of the box.

The wood soon assumed a purplish tint, and by occasionally trying fragments of the wood I had also placed in the box, with a bit of the dark filler I had already prepared, I could tell when the required shade was reached.

The tops and bases of table and pedestal were, for convenience, left off until fuming was done.

After they were filled and thoroughly dry, I applied two coats of good rubbing varnish, following up with a compound of pumice, oil and elbow grease, and the tone compares favorably with the other furniture, the fuming, darkening, and mellowing the wood without raising the grain, better than anything else but time that I know of.

I am now building dining table, china buffet and serving table of the same material.

ERNEST L. HUBERT.



A Correction

To the Editor:

Wayne City, Ill.

Referring to Mr. A. W. Woods' article in the November number, how to frame the roof for a sixteen sided building, he says the tangent for $22\frac{1}{2}$ degrees is .14421 and this multiplied by 12 equals 4.97052. I do not understand how he figures it that way. Would like to see it explained in next number.

Wm. R. McCoy.

Answer:—We are glad Mr. McCoy calls attention to the error, which is caused by the two first figures in the decimal being transposed. Instead of being .14421, it should have read .41421. Thus, $.41421 \times 12 = 4.97052$.

A. W. Woods.

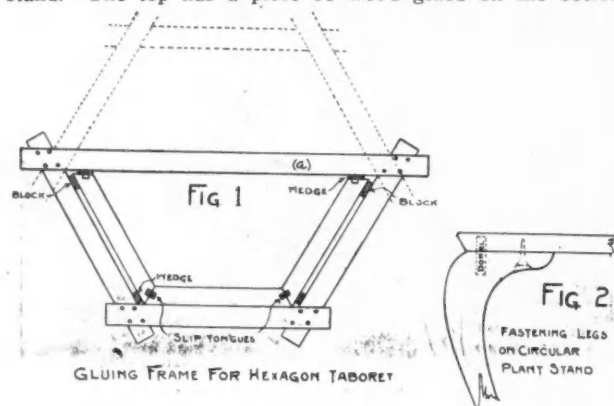

Brick Wall Construction

To the Editor: Butte, Nebr.
I am erecting a brick building to be used as a county jail and would consider it a favor if you could answer the following questions:

HERE ARE THE SPECIFICATIONS:

Brickwork—All walls are to be carried up straight, plumb and true, with a line on both sides and faced on both sides. There will be no plastering on inside of building. All brick to be properly bedded, tied with brick headers, four courses between. Work in regular bond and strike all joints neatly on both sides of wall. Joints in face work to be 3/8-inch thick.

Exterior Face—To be Clay Products Co., Sioux City, No. 5 dark round edge paver, laid with racked joint 3/8 inch deep. Use this brick from top of cement base to cornice line.

Interior Face—To be Hocking Valley Fire Clay Co., Nelsonville, Ohio, and Sunderland Bros. Co., Omaha, No. 103 buff salt glazed brick laid with flush struck joints. Use this brick from top of cement base to plate line.

Common Brick—To be Sioux City, Iowa, hardest shale brick, both solid and hollow. Use solid brick from grade up to floor line, and hollow brick for center of walls above.

NOW THE QUESTIONS:

1. Are the brick headers better than wall ties?
2. Does the brick header every four course allow for a sufficient bond?
3. Would not the brick headers carry the frost and cause the inside wall to be damp?
4. Would you advise running each course straight up, using wall ties or putting in brick headers?
5. If wall ties are used, how many courses between?

F. R. SMITH.

Answer: We do not see how you are to change the specifications for this building which you are constructing if your contract for the erection of this building is based upon these specifications.

We consider that brick headers will make a stronger wall in the case shown if all bricks are of the same thickness.

We also consider that a line of brick headers every fourth course would allow for sufficient bond.

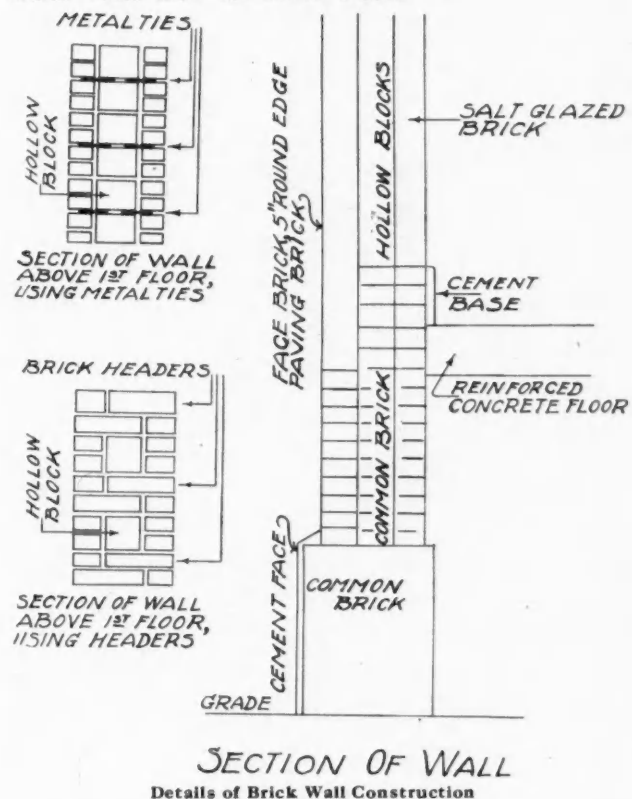

We also consider that brick headers, arranged as shown in your sketch, would probably cause the inside of the wall to collect dampness to some extent. If the exterior bricks are of very hard and dense material, and the interior bricks of the glazed finish type, we do not believe that exterior moisture would penetrate the wall to any great extent, but condensation of moisture might occur on the inner face of the wall, due to the difference in temperature of the two sides of the wall. Furring and plastering would prevent this latter condition.

When wall ties are used in brick walls, one tie should be used to each square foot of wall surface, or one tie to each brick in each fourth course of brick.

EDITOR.

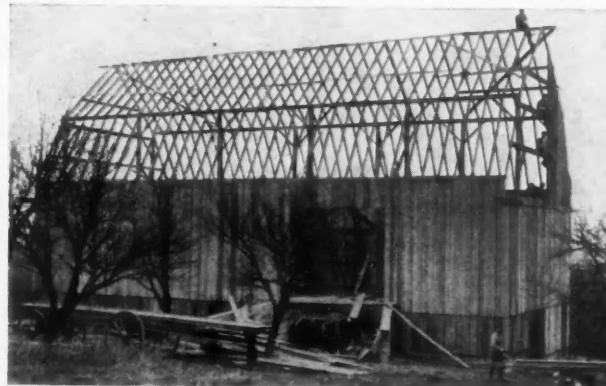

New York Barn Building

To the Editor: Boston, N. Y.
The skyscraper builders have nothing on us. We raise the stars and stripes too when we get up to the top with the framing. This photograph shows our gang at work on a barn 36 by 70 feet, 44 feet high to the peak.

SHERMAN TREVETT.

Lath Stains on Plaster

To the Editor: Spanish Fork, Utah.
In the December issue Mr. Henry Stuckenhoff asks what can be done to stop lath stains that show in brown color from staining through onto the finishing coat of plaster.

We use mostly cedar lath here and these stain the brown coat badly. By allowing the brown coat to become dry and then going over the stain with a wash of ammonia and water, I have very little trouble with stains showing in finish or third coat.

J. W. G. STEBBINS,

Contractor and Builder.

Carpentry Estimating—Basis 30 Cents

To the Editor: Pierron, Ill.
I am a reader of your paper for about two years and find a good deal of useful information in it. I wish you would have more reading matter in it on contracting and building.

I would like a little information on estimating carpenter work, with wages at 30 cents per hour, work like framing on houses, making window frames, and door frames, fitting doors, nailing base and casings, and the like. Maybe some brother chip would be kind enough to let me know through your paper.

I started contracting for myself two years ago and did all the work by hand; but got tired of that, being a believer in "Jimmie's" ways. I built me a portable wood worker with a three horse power engine, which I mounted on a truck and just hike to the job with it and let her rip.

I want to make a disc sander for my wood worker to be used on the saw mandrel and if you know of a way of making them you would do me a great favor to publish it in the next month's paper.

M. L. SCHILLY,
Contractor and Builder.

Outside Light Necessary

To the Editor: Oakland, Cal.
 I am about to prepare plans for a job I have to erect, and it is for a building 46 by 65 feet. The lower floor is to be taken up by a bank and grocery store and the second floor has four apartments. I have already prepared a sketch, but I would like to have your opinion on what would be the best and cheapest way to light the inside rooms of the apartments.

I consider it would cost too much to have open light well all the way as far as the front rooms. The entrance to the apartments is on the side and end of the building. It might be well to have the whole hallway covered in, but I will leave

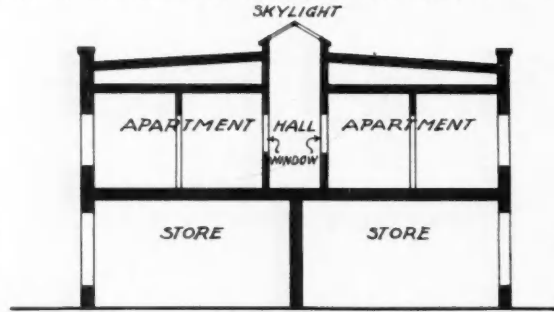

Cross Section Through Building

it to you for consideration. If it should be left open, the hallway or light well would have to be covered with heavy tin and covered again with an arrangement for walking on.

NEIL McCALLUM.

Answer: A metal skylight with ribbed or figured wire glass extending over the entire length of the central hall would furnish sufficient light for the hallway, but not for the rooms opening off it unless they have other outside light.

In office buildings it is not objectionable to have the inside or anterooms lighted from hall skylight, as such rooms can be made with partition walls practically all of glass. For living rooms, though, this wouldn't be satisfactory. The best way, and it is the only way that is permitted in cities that have up-to-date building ordinances, is to arrange the apartments so that all rooms can have direct outside light.

EDITOR.

Method of Quarter Sawing

To the Editor: Saranac, Mich.
 The writer is a subscriber to your valuable magazine, which I think carpenters, builders, sawmill, planing mill and lumbermen can hardly afford to be without. Of course, we all

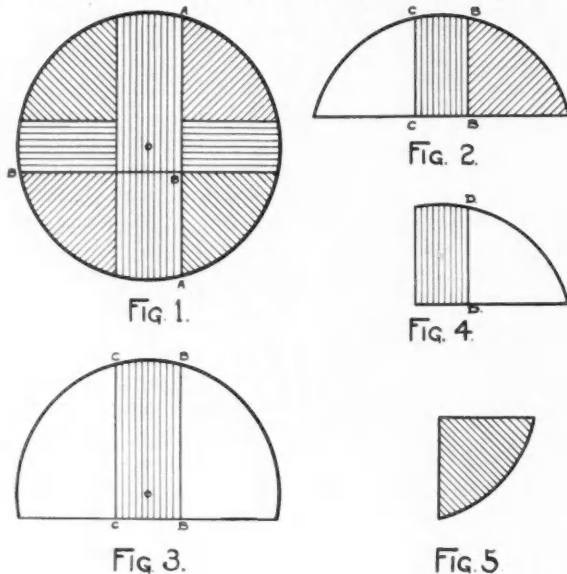

have opinions and an exchange of them is a good thing, because we profit by others' experience.

I have had years of experience in the saw mill and building and lumber business. In an issue of your magazine of some three or four years past, I saw explanations and figures telling how to quarter-saw oak, which did not just agree with my way of doing it, and, of course, I think my way the best way. I have tried both ways and am satisfied the enclosed description is quicker, easier and a great saving of material.

DESCRIPTION:—The first operation after placing the log on carriage is to split, or saw it at A A, Fig. 1. This (less than one-half log) piece is laid aside on the skids, Fig. 2. I then turn this, Fig. 3, piece down on head blocks and split or saw at B B, Fig. 1 and Fig. 3. Then I saw into boards to C C, Fig. 3. Turning this piece, Fig. 4, I saw to D D, taking what is left, Fig. 5, I turn bark side down and saw as per drawing. After this is all done I take the smaller one-half, Fig. 2, and saw as per drawing, splitting B B and sawing to C C. I often edge these quarters at the mill before sawing into boards, making them all of one width and they are the best part of the log.

LEWIS KELLY.

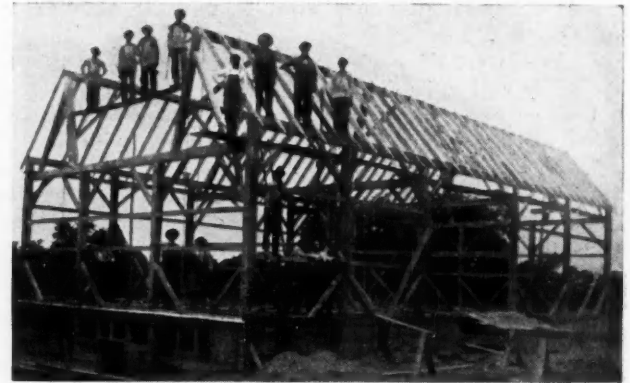

Barn Raising

To the Editor: Loretto, Minn.
 This picture may interest some of the boys. It shows my gang at work raising a barn. I am a contractor of frame barns all over the country. I build houses, too, but mostly barns.

EMIL BIEGERT.

Strength of Douglas Fir

To the Editor: Talent, Ore.
 Will you give me the figures for the breaking weight for Douglas fir and Oregon fir as it is locally known here?

C. E. FROMAN.

Answer—The following values are from the hand book of the Cambria Steel Co.:

AVERAGE ULTIMATE BREAKING STRESSES IN POUNDS PER SQUARE INCH	
Tension with grain.....	8,000.
Compression with grain.....	4,500
Compression across grain.....	800
Bending, extreme fiber stress.....	5,000
Bending, modulus elasticity.....	1,400,000
Shearing, with grain.....	500
AVERAGE SAFE ALLOWABLE WORKING UNIT STRESSES IN POUNDS PER SQUARE INCH	
Tension with grain.....	800
Compression with grain.....	900
Compression across grain.....	200
Bending, extreme fiber stress.....	800
Bending, modulus of elasticity.....	750,000
Shearing, with grain.....	130

EDITOR.

Experience with Dealers

To the Editor: Marceline, Mo.
 I find your advertising department a very convenient help. It keeps a carpenter posted on all the latest improvements in tools, which no up-to-date carpenter and finisher can get along without. There are very few hardware men outside of the cities that carry the latest improved tools. If we order them through our dealers we very seldom get what we order. They order from the wholesale house, and if they don't have what you order, the wholesale house will substitute and send something as near like the order as they have, and probably manufactured out of cheap-John stuff.

On the other hand, if you send direct to a good, reliable manufacturer you get the genuine article by Parcel Post quicker than it could be purchased through a home dealer. The home dealer will wait until he orders a bill of goods before he will get what you want. It makes it cheaper to him, but no cheaper to the buyer.

FRED DAVENPORT.



Trisecting Angles

To the Editor: Ithaca, N. Y.
 In the September issue, Mr. Weeden gives a method of bisecting a given angle by the use of a figure consisting of a circle of arbitrary radius tangent internally to a circle of three times that radius.

I follow readily his method of determining the point N formed by the intersection of lines AM and FB produced, and in this position, FN cuts off arcs AB and AF of equal length; but I do not see why point N is the locus of points where radius vectors may be drawn, each cutting off equal

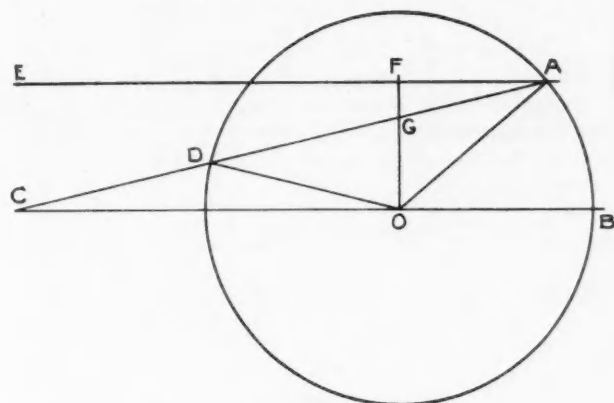

Method of Trisecting Any Angle

lengthened arcs from A, and within the limits of AF or AB. In other words, as Mr. Weeden expresses it: "This point (N) forms the basis for the trisection of any angle, for it is a known fact that if the line NBF is swung towards the point A, with the point N remaining stationary, for example, taking the position of the line NHK, the points of intersection (H and K) are always equidistant from point A, if the distances are measured along the arcs and not as chords between these points." Will Mr. Weeden explain why?

I beg to submit two methods I have used sometimes for trisecting angles. While geometers may object to the means employed, the finished product is absolutely correct and demonstrable geometrically.

To trisect a given angle.

Let AOB be the given angle. With O as a center and any radius OA, describe a circle ABD. Produce OB; place a pin at A for a guide and with a steel square, or rule, or straight edge and compass held against pin at A, slide along line BO, produce until CD equals radius OA. Then angle ACB = 1/3 of the given angle AOB. For the lines CD = DO = OA = OB.

Angle DCO = DOC = 1/2 ADO = 1/2 DAO.
 ADO = 2ACB.
 ADO + ACB = AOB.
 ACB₃ = AOB.
 ACB = 1/3 AOB.

To trisect, without using the circle, any angle EAO.
 At any point O draw a parallel BC to EA.
 Drop a perpendicular OF from O upon EA.
 Then as before, slide along BC until CG = 2AO.
 Then EAC = 1/3 EAO, as may be seen by following the first method.

CHARLES GRAY.



Stair-Work Question

To the Editor: Egin, Iowa.
 Will you please let me in on the correspondence department? I want a little information.

Can some of the expert stair builders give me a method of scribing the wash board or finished string, to the treads and riser, the treads and riser being already in place, and wash board is required to fit over them?

ALEX PAGAN.



Heavier I-Beam Needed

To the Editor: West Salem, Wis.
 I am intending to erect a building 32 by 120, basement to be used for pool room and bowling alley, main floor for a moving picture show and second floor for offices. Would like to know if 20-inch, 65-pound I-beams are heavy enough to carry the load, by having one every 14 feet.

Beams will be 31 feet long and about 28 feet between piers.

A. C. CULLMANN.

Answer: One of these beams will carry safely about 40,000 pounds of uniformly distributed load, since each beam will support about 448 square feet of floor, this will allow a total dead and live load of a little less than 100 pounds per square foot of floor surface. Since this unit load is a little light for this type of construction, we would consider that a 20-inch, 75-lbs.-per-foot beam would be of better service in this location. Whether this beam will be of sufficient size to satisfy your local building ordinance, will be a matter which you will have to determine in your own town. We would suggest that a beam of this height should be supported laterally to prevent the beam from lying over sideways when under load.

EDITOR.



Framing for Church Shed

To the Editor: Scotland, Ont.
 Some of the other builders may be interested in the way we are building the new sheds for the Baptist church here. The photo pictures this work when about half finished. It is now all enclosed, like a barn. The sides are covered with dressed boards and the roof sheathed and covered with

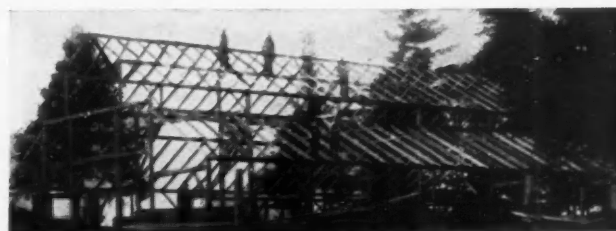

Frame Work for Large Church Shed at Scotland, Ontario

corrugated iron. This is quite a sizable shed, 90 feet long by 52 feet wide.

The picture shows myself and three men, also the minister of the church.

C. S. STICKELS.

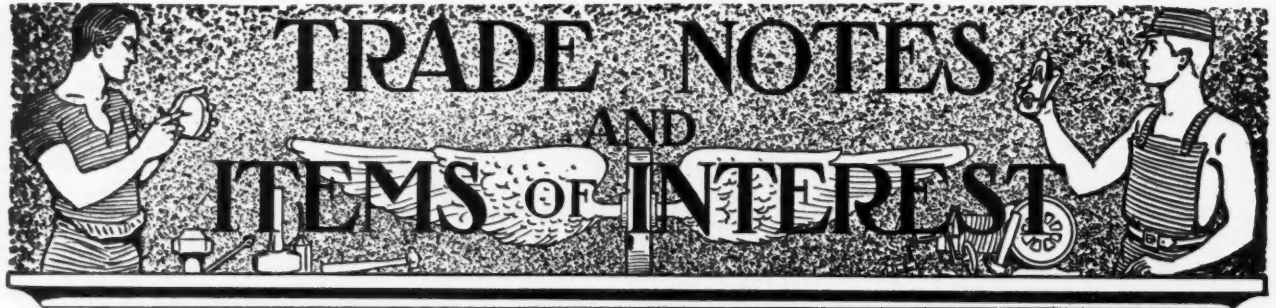

Through this department the editors aim to keep builders, contractors, carpenters and architects in touch with what their friends, the manufacturers, are doing for them in new or improved tools and machinery, methods and materials—pertaining to building. Items for these columns must have real news value; they are offered here as interesting information for our readers; they are not advertising. No matter will be printed here simply because some advertiser wishes it. Likewise, no matter will be excluded simply because the article described is not advertised in this magazine. Suggestions for the betterment of this department are requested of our readers.

Curing Double Concrete Walls in Cold Weather

The great cost of insuring and keeping up a large number of widely scattered buildings is a matter that is receiving much attention from railroads and corporations at the present time. The fact that these scattered plants must be erected largely by local labor and materials has worked against modern construction.

To a milk company whose stations are scattered over several states, the question of sanitation and insulation is also of especial interest. H. P. Hood & Sons Company, of Boston, have given this matter considerable attention, as they are building constantly.

Late in the summer, this company lost a small plant located near Wells River Junction, Vt., by fire, and it was decided to replace this plant with concrete. The Van Guilder hollow wall construction was decided on as being particularly adapted for their use because the Van Guilder machines, being light, could be easily and cheaply transported between their widely scattered plants, and being simple to operate, the necessary help could be secured locally.

The construction in this case was two 4-inch walls separated by an air space of 2½ inches for insulating purposes. This double construction is particularly desirable wherever a high degree of insulation from heat and cold is desired, and it also effectually prevents dampness.

The rebuilding was delayed for various reasons until, after the first of November, and as the plant was located almost at

the base of the White Mountains, the builders were considerably perplexed as to how to keep the thin walls from freezing, and as to whether they would set fast enough to allow continuous work with the wall machines.

As the buildings consisted of an ice-house, 30 by 45, with 19-foot walls; a creamery, 41 by 30, and a receiving shed, 13 by 15, with 12-foot walls, there was a large exposed area to be protected, but Mr. C. D. Gilbert, representative of the

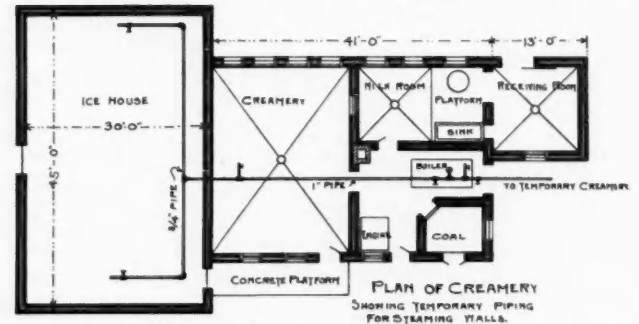

Pipes Laid to Steam Walls Spaces

Van Guilder Company, was equal to the emergency. There was a boiler on the premises that had been in the burned creamery and this suggested to Mr. Gilbert that steam might be turned into the continuous air space and the walls steam cured. Plenty of old pipe was at hand and lines were run so as to reach every part of the building by means of steam hose connected to the walls. As fast as built, the walls



Thin Double Concrete Walls Laid and Steam Cured in Freezing Weather at Wells River Junction, Vt.

were covered with strips of tar paper weighted with boards and steam turned on, with the result that the concrete set in about three hours, so as to allow another course to be laid, and was past the danger of freezing in six hours. The entire walls were erected in three weeks. The thermometer went as low as 20 degrees, and there was at one time 4 inches of snow, yet the work was carried on successfully.

This is evidently the solution of the problem of how to protect and cure double concrete walls in cold weather, and will no doubt result in extending the season for this type of construction work several months, as the results are positive and the cost very small. In fact, this steam curing process should place concrete in its proper place among building materials where double walls are specified, as it can be used in any weather suitable for other construction work.



New Smith Mixer Catalog

We have just received a copy of the new Smith Mixer Catalog No. 300, which is just fresh from the press. From a glance through its pages it is evident that the Smith line for 1914 is as complete as can be. We trust that the contracting trade will appreciate the quality of design and workmanship which is being put into the Smith mixer.

There are several changes from last year's machine. One of the important variations is in the design of the water tank. This tank is an enclosed affair, equipped with air valve and three-way inlet and outlet valve. It is also equipped with gauge glass for showing the amount of water. This is a better tank than they have put out before, and one which will appeal to the contractor.

The power tilt has been speeded up so that, in the future, the tilting action will be far quicker, and the drum will discharge with greater rapidity.

The Smith sideloader has been greatly altered. The vertical frame-work has been greatly reduced in height, and the hoisting mechanism entirely altered and improved.

The new Smith "Mascot" mixer is illustrated and described. This is a new type machine and one which will appeal to the small contractor by reason of its light weight, extreme portability, easily operated loader, ground level charging skip, all steel construction and a four-foot mixed batch. This is the size which the contractors during the past two years have been clamoring for. Since putting this machine on the market the T. L. Smith Company report it has met with instant favor and there is every prospect of its being one of the best selling Smith mixers. One of the strong features of the Smith "Mascot" mixer, as this little machine is called, is the fact that a great deal of weight is eliminated in the removal of the swinging frame, main rollers, edge rollers, etc., necessary in the large machine. This small drum is simply swung between the two trunnions, being pivoted slightly below the center so as to permit of a quick, easy tilting action, which gives this machine a fast, even discharge. Another strong point is the fact that the drum ring and driving pinions are totally enclosed in a dust-proof casing. This is filled with grease which is constantly forced outward by the action of the gears, and in this way effectually prevents dust from entering.

We would call particular attention to the renumbering of the Smith mixers, as shown in the following:

New No. of Mixer.....	104	106	110	113	117	122	131	140	162
Old No. of Mixer.....	Mascot	10	11	New	12	13	14	16	18
Size of batch, mixed concrete cubic feet.....	4	6	10	13	16½	22	31	40	62
Horse Power required....	2	4	6	8	10	14	18	25	35

A Valuable Help in Building with Cement

Your farmer customers, who will build new corncribs, granaries, barns, hoghouses, coalhouses, sheds, garages, etc., will appreciate the valuable help offered in the iron studding sockets, manufactured by G. M. Ross & Co., 1244 Broad Street, Grinnell, Iowa.

The illustrations here and on another page, give an excellent idea of these sockets, and just how they are used in cement floors and cement foundations. Ross & Co. call their sockets the "100 year" post supports.

Where Ross post supports are used, there are no sills to rot away, or no toenailing to rust out.

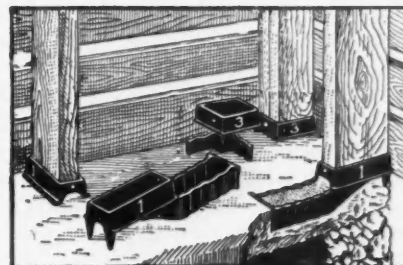

Ross Post Supports for Concrete Floors and Foundations

Numerous other advantages are told about in the extremely interesting little booklet, "How to Build Cement Floors or Cement Foundations," which G. M. Ross & Co. have issued. A postal card or letter will bring this booklet by return mail. Better drop a line for it now. It will help you when your next customer calls.

Many of your customers are building cement floors or cement foundations.

Building material dealers are making splendid profits selling Ross post supports. They find every socket sold gives excellent satisfaction. The first sale in a community always leads to many others, which means many sales with good profits for dealers.

Write G. M. Ross & Co. today.



A New Detachable Screen Door Hinge

The Shelby Spring Hinge Co., Shelby, Ohio, who for years have manufactured an extensive line of screen door hinges, and builders' hardware, have added to their line the Shelby detachable-screen door hinge. non-hold-back in character, and made entirely of wrought steel. The flanges of this hinge have embossed ribs and screw holes, which makes a strong and very attractive hinge.

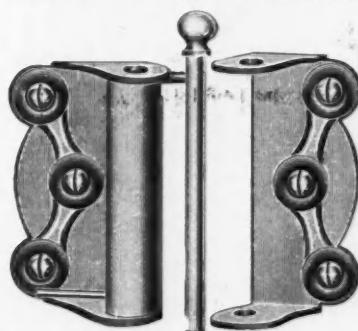

Shelby Detachable Door Hinge

To detach, pull the pin and remove the door.

The flange with the pin and spring remains on the door.



Sell Lighting Systems

There is a growing demand throughout the smaller towns and rural communities for modern lighting. Davis acetylene systems are popular wherever they have been tried. One user makes two others. This makes it easy to sell Davis systems once it is introduced into a community.

The Davis Acetylene Company, 90 Crawford St., Elkhart, Ind., are now making architects and builders a special proposition to act as their local representatives and salesmen. You will find it worth while to write them for complete details.

Scraping Old Varnished Floors

By E. W. Anderson, Floor Smoothing Specialist

Have you ever tried to scrape an old varnished floor by hand? Many a man has tried it once, and said, "never again!" If you are one of these I cannot blame you, for I have also had experience and know what it means.

I have been in the floor-scraping business nearly all my life, but only until the last few years have I willingly accepted the task of scraping old varnished floors. Even the work of scraping new floors by hand is hard and wearisome toil, but when it comes to scraping old floors, it is punishment indeed.

Like thousands of others, I dreamed of the possibilities of doing this work by machinery, and some ten years ago, began planning and working towards this end. It finally became a hobby with me. I worked and experimented with a number of machines of various makes and styles of construction, but it seemed impossible to get a machine having sufficient weight to hold the scraper below the surface and at the same time working easily enough to enable a man to pull it.

It is evident that to scrape a floor requires, first, a scraper edge large enough to get under the grit; secondly, enough weight to keep it under the full length of the cutting stroke, and third, a proportionate amount of motive power.

Not until I developed the Triple "A" spring-driven floor-smoother, with its three prominent advantages of weight, power and adjustability, was I fully satisfied that I had found the practical, all-around floor-surfacing machine.



Old Varnished Floor Being Easily Refinished With Machine

The Triple "A" is a machine weighing 75 pounds, and carrying two additional weights of 50 and 25 pounds each, which may be properly adjusted over the scraper blade, so as to obtain whatever degree of pressure is required in proportion to the size of scraper edge used, and the kind of work at hand.

It is further equipped with a spring motor, which generates and furnishes its own power from the natural action of the machine. The forward stroke (non-productive in other floor scrapers), automatically winds up the motor spring, which stops the machine at the proper distance, and starts it back on the cutting stroke, without additional effort on the part of the operator, except to guide the machine and return it for the next cut.

It is in the combination of weight and motive power, that this machine shows its advantage. It has the necessary amount of weight to make a scraper edge of any size cut full depth the entire length of the stroke, thus avoiding the grit and making a smooth cut; and it has a power of its own, which relieves the operator of more than half the labor.

It can truly be said, that this machine has robbed floor scraping of its terror, for with a Triple "A" spring driven floor-smoother, one man can scrape and sandpaper ten times the amount of floors ordinarily done by hand, without half the effort and pain.

Owing to the growing demand for resurfaced floors and the difficulty of doing this work in the old way, many readers will be glad to learn that the old "bug-bear" of scraping old varnished floors has at last been killed off—the work can now be done rapidly, and with comparative ease by machinery.

Ten years ago, hardwood floors were considered a luxury, enjoyed only by the well-to-do, but their popularity has steadily grown until now, even the "common folks" would not think of having anything but hardwood floors in their homes.

Today, the cost of hardwood floors is but very little more than that of common floors, but the additional service and satisfaction found in them is many-fold.

A great deal depends, however, on the way a hardwood floor is surfaced; to be enjoyed it must be smooth and even. It is a comparatively simple matter to surface a new floor so as to leave it free of edges, etc.; but the trouble is that most new hardwood floors do not stay smooth.

Even the most carefully laid and surfaced floors will warp and turn up edges during the first year, owing to the varying conditions of heat and cold, and it is only by resurfacing the floor after it has laid long enough to become thoroughly settled, that a permanent smooth surface can be obtained.

When taken into consideration that it costs no more to resurface a varnished floor with a Triple "A" machine than it does to surface a new floor by hand, it can readily be seen that it pays to resurface a hardwood floor after it has become settled, as it will then stay in shape.

Carpenters and floormen will find, with very little effort, any number of floors in their localities, which need resurfacing; and most of the owners are willing to pay a liberal price for having the work done. The trouble has been heretofore, that it was too hard work to scrape a varnished floor by hand, and most would refuse the job at any price. Not so with a Triple "A"; with this equipment, you will go looking for the work, instead of dodging it, and will find it a most profitable enterprise.

Thousands of carpenters are already engaged in this business, but it is as yet scarcely begun. Like in all other lines, the first to satisfy a popular demand reaps the richest harvest. It goes without saying that a machine which will successfully resurface old floors, can also be depended upon for surfacing new floors of all kinds.

I will be glad to furnish full information on this subject to all who write me, care of the Triple "A" Machine Company, Room 311, 300 W. Indiana Street, Chicago.



Montross Shingles

A very interesting catalog came to our desk the other day from the Montross Metal Roofing Co., successors to Montross Metal Shingle Co., Camden, N. J. This is their catalog H-3, entitled "The Best Roof Under the Sun." It is a 40-page booklet, very well illustrated, many of the photographs and drawings being in two colors. The shingle styles are shown very clearly, both as they appear as individual shingles and when applied on the building. Some instructive diagrams are presented, showing the best way to lay metal roofs, and the booklet also tells how to paint them for greatest durability.

In addition to their line of metal shingles of various patterns, this catalog also features some well designed finials made of galvanized iron and zinc. These give any building a finished architectural appearance.

The manufacturers will gladly send this catalog free of charge to all of our readers who will write them.

Story of Luther Grinders

By L. L. Newton, Sec'y Luther Grinder Mfg. Co.

The Luther Grinder Manufacturing Company was started by Mr. C. J. Luther about 20 years ago. He first built a hand power sickle grinder for farm use that was such a success with the neighbors that he saw great prospects in it. Accordingly he associated himself after a time with the C. J. Luther Company of Port Washington. They put out thousands of sickle grinders the country over with emery wheels. It was shortly seen that Milwaukee was a better manufacturing center than Port Washington, so the factory was moved to Milwaukee. About that time his brothers came in with him, and for many years, the concern was operated under the name of Luther Bros. Mfg. Co. About the time of making the move to Milwaukee, the new abrasive, carborundum, had just been discovered. Its advantages were seen at once and a good deal of the success of the company has been due to the superior abrasive that has always been used. Carborundum was for many years the best abrasive it was possible to obtain and has had a great popularity.

About two years ago, the company got track of a new abrasive which they have been putting out on the market under the name of Dimo-Grit. Dimo-Grit, although made similar to carborundum, is claimed to be an improvement over it in several ways. In the first place, it is an ideal substance for steel grinding. You will find that large foundry and machine shops the country over use Dimo-Grit for bronze, cast iron and other low tensiled articles. For steel and high tensiled articles they use a different substance which

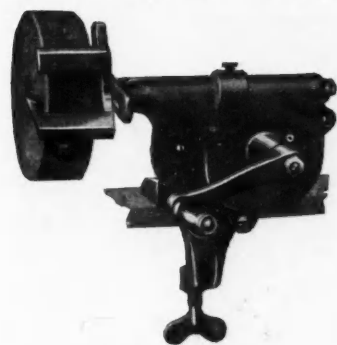

A Popular Grinder

is along the line of Dimo-Grit. As edged tools are invariably made of steel, the same abrasive that is used in large foundries for steel grinding should be used on hand power machines. For tool grinding, Dimo-Grit is as fast cutting as carborundum is, as cool cutting as carborundum and in addition it leaves a smoother cut edge with less fagot. This is due to the character of

the substance. Its grains are not quite as sharp and do not leave as rough an edge.

During this time improvements have continually been made in the mechanism as well as the abrasive. Several years ago, high speed was invariably obtained by the use of cast gears. This is a very efficient method of carrying power, but it is noisy. Several years ago, therefore, they put on the market machines with cut steel gears. Although you cannot do any more work on these machines, they are me-

chanically more perfect, and as a consequence take better with mechanics.

They have developed the various machines until now they have nearly fifty different styles of grinders. They are for every purpose, from machines that are "just the thing for Mi-Lady's Kitchen," up to heavy machines to be run with engine power. In between these there are any number of grinders. This includes machines for carpenters, machines for mechanics, and machines for woodmen. Foot-power machines for mechanics, and foot-power machines for farmers, hand-power sickle grinder and grinders for use with gasoline engines. Besides that, they make a number of specialized machines, such as a shear sharpener for barbers' use, the finest kind of sharpener that there is. No matter for what purpose a grinder is wanted, there will be found some machine in the Luther Line that will exactly fit its requirements.

There are many things that can be done only by the test of time. No matter how carefully thought out any proposition may be, it is bound to be very imperfect compared with the finished product. The Luther Line is no exception.

During the development of the business, they have found certain types of machines which are justly the most popular and have the largest field. They say that the Best Maide Grinder is the most popular hand machine on the market to-day.



C. J. Luther



Modern Factory Now Occupied

Quality is another watch-word of the company.

The mechanical part of their grinders is superior. Their inspection department costs a great deal of money, but this is more than made up for by the permanent satisfaction of the goods. As Mr. Simmons has said "The recollection of quality remains, long after the price is forgotten."



Money in Chair Tips

Chair tips take the place of casters and do not mar finely finished floors. Carpenters find it easy to sell these in connection with their regular work. The Evergrip Gliding Caster Co., Department V, 20 Warren Street, New York City, have a good proposition along this line. They will also send out a sample set free of charge.

Buckeye Folding Saw Vise

A new Buckeye folding saw vise is now being offered, made of all steel. This makes a more durable and a lighter tool to carry. It is designed on much the same principle as the cast-iron Buckeye folding saw vise, which has been on the market for the past eleven years and which has met with a wonderful sale in that time. These new vises weigh but 2 pounds each, and when folded up, take up but little space. The jaws are 14 inches long, therefore requiring only one shift of the saw while filing.

A new all-steel folding vise that requires no shifting at all is their "No Shift" folding vise. This is a double form of the other vise. It weighs 4 pounds and takes up very little room in the tool chest.

This "No Shift" vise will be appreciated by carpenters. Many of them up to this time have preferred the clumsy,

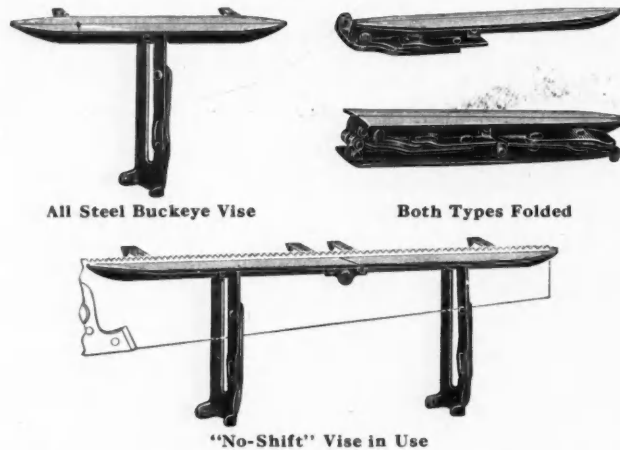

home-made, 2-by-4 affair just because they don't like the idea of shifting the saw while filing.

These Buckeye saw vises can be attached or detached without screwing or clamping, by means of the folding hooks which are driven into the bench, or a piece of 2 by 8, which can be set in a window at the desired height. For further particulars address the Buckeye Saw Vise Company, 2050 W. 55th St., Cleveland, Ohio.

Fair Treatment by Starrett

We are gratified to learn that the L. S. Starrett Co., Athol, Mass., are again this year paying a sum equal to 2 per cent of the entire amount of each employee's wages during the year 1913. This action has been taken by the directors of the company, in spite of the fact that there has been a general business depression. This announcement comes as pleasant news to those who are interested in manufacturing and in the co-operation of labor with manufacturers.

Want a Motor-Truck?—Buy Front Wheels Only!

Merchant & Evans Company of Philadelphia has just put on the market a four-five-ton tractor truck. The novelty and usefulness of this unique vehicle consists in the arrangement of the motor, clutch, transmission and jackshaft as a unit on a dead front axle, so that axle, wheels, engine, transmission, jackshaft, etc., turn with the front wheels.

The steel frame, which extends rearwardly from the pivot is mounted on steel-shod wheels and is regularly equipped with a steel body. This body consists essentially of a heavy plate iron or plate steel floor and strong steel side panels, above which stakes extend, connected by steel chains.

Although this is the standard body construction, any other kind can be placed on the frame; in fact, only the forward

unit may be purchased, if necessary, so arranged that this can be attached to any kind of vehicle, after the front wheels of the said vehicle have been removed. Consequently a very interesting feature is the possibility for a company to use its old vehicles, which have suitable bodies for its work, thus converting them immediately into motor-driven trucks of four-ton capacity, at a cost very much less than any four-ton truck could be purchased for, and with lower upkeep. Furthermore, the major portion of the load is merely carried on a body with steel wheels, thus saving the cost of rubber tires.

As this combination vehicle is, of course, pulled by the power-driven front wheels, and not pushed from the rear, it requires less power to propel the given load, consequently less fuel consumption, and does away entirely with skidding. Only 30 per cent of the total load is required to give full traction to the front wheels, as the fixed front weight, plus about 15 per cent of the load weight only, gives all the tractive weight needed.

Rated as a four-ton vehicle it carries 8,000 pounds, but is claimed to be strong enough for 10,000 pounds. The weight loaded would be under 15,000 pounds.

Every Kind of Sheet Metal for Building

The Galesburg Sheet Metal Works, Galesburg, Ill., wish to get in touch with carpenters and builders and figure with them on sheet metal work. These people manufacture sheet metal cornices, metal ceilings, skylights, finials, crestings, etc. They make up any design in sheet metal, following architects' drawings or builders' sketches. Their catalogs and circulars are valuable to have on hand for reference. These will be sent promptly to any of our readers who are interested.

Iron and Steel Processes and Their Relation to Corrosion

PORTIONS OF A PAPER READ BEFORE THE COLLEGE OF APPLIED SCIENCES SYRACUSE, UNIVERSITY, DEC. 17, 1913

By J. T. Hay

Chief Metallurgist and Chemist of the Stark Rolling Mill Co.

It is to Tubal Cain that we owe the incentive which has resulted in the development of iron and steel to its present condition. It was he who started mankind on a new quest, the quest of the use of iron, and consequently we have the

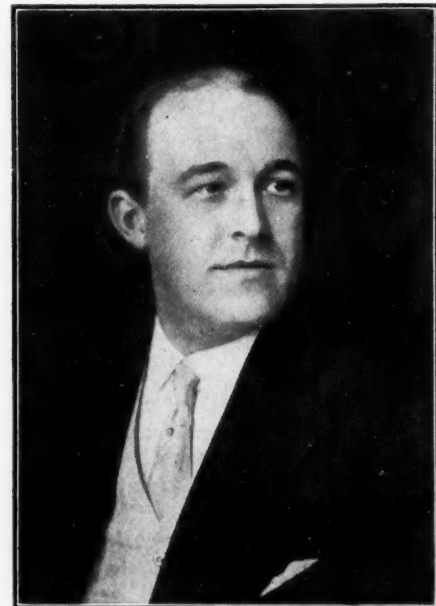

J. T. Hay

multitudinous products which are made from iron and steel and upon which we place so much dependence. The sons of Tubal Cain in every age have been striving to the utmost to increase the use of steel and iron, better its quality, and increase the quantity, in order that we may have at our disposal, not only the best, but a plentiful supply of it. It is un-

FREE!!

Overland Automobile

50 Splendid Prizes!

Contest
Starts Feb. 15th
Open to Contractors
and Carpenters Only

We are going to distribute among Carpenters and Contractors 50 splendid prizes, including a brand new 1915 model 5-Passenger OVERLAND AUTOMOBILE. Prizes total \$1,225. No dealers or individuals who are *not* engaged in the building industry will be allowed to enter the contest. Write at once for Free Contest Circular.

Win the Overland or a Splendid Chest of Tools

This contest is for the purpose of keeping old and new customers awake to the big inducements on Building Material offered in our Grand Free Building Material Catalog. The prizes are practical, valuable, and well worth hustling for. In addition to the Automobile, there are hundreds of dollars' worth of the finest tools—*everything you want*. Start early—no time to lose!

Contest Circular Free

The big free Contest Circular gives complete specifications of the Overland Automobile and describes and illustrates the immense assortment of tools to be distributed. Gives Rules of the Contest and full information.

Ask for latest edition of our Grand Free Catalog of Building Material. Write for Big Free Circular today and go after *that great big beautiful Overland!*

GORDON-VAN TINE COMPANY
 684 Case Street
 Davenport, Iowa
 (278)



doubtedly true that at the present time more men are engaged in this industry and its allied arts than in any other single industry of the country, and after all these years of careful research and investigation the art is still in its infancy, and there are many problems which yet remain to be worked out. The progress in the art of manufacturing iron and steel has been most remarkable in the last years and of all the factors which have contributed towards it none have been more influential than the destructive forces of corrosion, which have challenged the best efforts of man to produce a permanent iron or steel product, and it is a well established fact that the processes of manufacture have much more to do with the final lasting quality of the material than was formerly supposed. In order that we may trace the effects of the different stages of manufacture, let us begin with the ore and follow it through to the finished sheet.

The basis of all iron and steel manufacture is iron ore, and of the forms in which it occurs, the oxide is of the most service to the steel industry. This ore is the element iron combined with oxygen and containing quantities of various other impurities, such as silicon, sulphur, phosphorus, etc. It is the content of the phosphorus in these ores which determines whether or not they are "basic" or "Bessemer"—that is, whether the ore can be made into pig iron, suitable for the Bessemer converter or the basic open hearth furnace. The Bessemer process does not permit the elimination of sulphur and phosphorus beyond certain limits and this is true down to the finished sheet. Therefore, it is necessary, in order that the finished product may be of superior quality, that we must go back to the ore, determine the amount of sulphur and phosphorus which is contained therein, deduct what amount is supposed to be removed by the furnace operations and thus determine whether the ore is suitable for Bessemer steel or not.

The basic process is capable of utilizing the ore rejected by the Bessemer and produce an equal and even superior fin-

ished product, but there are some ores which neither process can successfully treat, and unless careful watch is maintained on the ore supply, there is ample opportunity for some of this low grade ore to find a way into the market, in some form of iron or steel, which will result in the latter's speedy failure. It will not be necessary to go into the detail of blast furnace methods. There are, generally speaking, four kinds of material put into the blast furnace fuel, iron ore, fluxes and blows air. Four kinds of material are discharged from it, pig and slag, tapped from the lower part of the furnace and gas and dust which pass out through the top of the furnace. The solid materials are charged in the regular way and in alternate layers, coke is the fuel most generally used. As the iron is formed in the furnace, it drops to the lowest portion of the hearth from which it is tapped after four hours, and is either cast into pigs or transferred in the form of hot metal to either the converter or open hearth furnace. Let us follow some of this hot metal to the Bessemer converter. This large pear-shaped vessel is lined with refractory material and the molten metal is poured in at the top. A current of air is passed through this already highly heated material, oxidizing the silicon carbon and manganese in the metal bath, and causing an increase of the temperature until the point is reached when the metal has been purified to a degree which makes it acceptable to a certain class of purchasers. We will now return to the blast furnace and take note of the pig iron which was cast either in sand or in pig iron machines. It is sold to Bessemer or open hearth steel manufacturers who do not have a blast furnace in connection. Either hot metal from the blast furnace or cold cast pig iron, together with scrap iron and the necessary fluxes are placed on the hearth of an open hearth furnace and melted by the heat of gas made in producers from coal, or by natural gas when it can be secured.

The time required to produce a heat of steel in an open hearth furnace will vary from 8 to 12 hours, dependent upon

**Quality Is
Economy**

*Here are some Testings of our
Q and E Floor Varnish*

Boiling water was poured on it for five minutes—and it was unharmed.

It was vigorously washed with hot Ivory-soap suds—and it was unharmed.

A solution of 50% pure alcohol was poured over it—and it was unharmed.

It was scratched with nails—and the scratches did not show white.

An iron safe was rolled across it, the casters perceptibly mashing in the surface of the soft wood—but the varnish did not crack.

Show this advertisement to customers.

**The Varnish
That Lasts
Longest**

Murphy Varnish Company

FRANKLIN MURPHY, President
Associated with Dougall Varnish Company, Limited, Montreal, Canada.

NEWARK,
N. J.
CHICAGO,
ILL.

You will get SPECIAL ATTENTION if you tell Advertisers you read American Carpenter and Builder.

\$751.39

For Lumber, Millwork, Hardware, Paint, F. O. B. Seattle. 7 Big Rooms, Bath and Store Room.



\$675.64

For Lumber, Millwork, Paint, Hardware, F. O. B. Seattle. 5 Rooms and Bath.



For the newest and best in plans get Hewitt-Lea-Funck's new book

For over a year, a big staff of the best architects on the Pacific Coast and Central West have been working on this book, and now it's ready for you—ready with a collection of plans worth thousands and thousands of dollars—ready with what contractors tell us is the most practical book of house plans they've ever seen—plans that will enable live contractors to land jobs that otherwise you would have missed.

Make More Money

You can make just twice as much money during 1914 if you get away from buying lumber that carries the profit tax of the middlemen. Buy from us, the producers, the manufacturers—our low prices will help you

Beat the other fellow

who is following "custom," instead of buying where he can get most for his money and better quality, too. You can get more jobs, and make more profit on each job by dealing with Hewitt-Lea-Funck, because it means you will

Get better lumber at a big saving

We sell you fir, the world's best all 'round lumber, also cedar, spruce, and western soft pine, cut from trees in our forests—sawn and planed in our mills. You save up to 60% and get fine, clear, straight-grained, old-growth lumber, that's easy to work, strong and lasting—that makes friends for you when you build with it.

Plan Spring jobs now—

Now, while you have time, investigate thoroughly our proposition. Get our Price Sheet, showing delivered, freight-paid prices on lumber, shingles and millwork. See how much we can save you over local prices. Send us a bill to figure, and we'll give you a delivered price that will surprise you. Find out about our free architectural service for contractors and builders. First of all, get the Plan Book. It will come to you by early mail, if you fill out the coupon, pin it to your letterhead and mail today.

Silos at up to 60% Saving
 Don't miss the money to be made on Seattle Silos. Ask for our proposition to you, on the coupon.

HEWITT-LEA-FUNCK CO.
 408 Crary Building, Seattle, Wash.

Thousands of dollars worth of plans ranging from bungalows to farm houses

The pictures at the head of this page tell the scope of the book. One is the picture of our design No. 515, as fine and practical a bungalow as we have ever seen. The other is a picture of design No. 713, famous all over the country, as Hewitt-Lea-Funck's money's worth farm house. You'll find in this book—no matter where you live—plans that will please the people with whom you "talk building." We have looked out for such important matters as economical heating, by making the houses compact, so that when furnace is not desired, a coal stove will answer. We have considered the hot nights, by planning bedrooms with windows on two sides, to insure a cooling cross breeze. These details make the book valuable to you as a real builder.

Guaranteed costs that show just what is furnished—we guarantee "No Extras"

On each page is shown the F. O. B. Seattle price of Lumber, Millwork, Hardware, Paint, Electric Bell—everything, in fact—quality absolutely guaranteed, and quantities guaranteed to be sufficient. By this we mean that if we don't provide enough of any item, we'll make good or let you buy elsewhere at our expense. We'll gladly give you delivered price on any house. Plans cost nothing when we furnish materials, and they're practical plans, just as practical as the book.

Throw the work and worry of estimating on to us—turn your time into money

Get our plan book, our price list, and full particulars of our proposition to you. In getting the plan book, you're getting a better book than is usually sold for 50c to \$2.00. If changes are desired, we'll make them without charge. It has cost us thousands of dollars to get out this book. The paper and printing cost 30c per book. But we'll send it to you for 10c. Cut out the coupon, enclose in an envelope with 10c and mail today.

Hewitt-Lea-Funck Co.,
 408 Crary Building, Seattle, Wash.

(Be sure to write plainly and pin this coupon to your letterhead.)

Please send me at once:

- New Book of Plans, for which 10 cents is enclosed.
- Catalog and General Price List of Lumber and Millwork.
- Special Silo Proposition.

Name _____

R. F. D. or Street No. _____

Town _____ State _____

You will get SPECIAL ATTENTION if you tell Advertisers you read American Carpenter and Builder.

the class of material to be produced. But during this time there is ample opportunity to remove many impurities which we know to be harmful to the steel, by a careful and thorough treatment of the mix and to make accurate analyses before taking out the metal so as to know whether or not it is the proper composition for the purpose for which it was intended. It is a recognized fact that the open hearth furnace alone is suitable for the production of high grade metal in large quantities. The electric furnaces are rapidly forging their way to the front, but they have not been long enough in the field, for us to accurately determine their position. Therefore, we will deal with the open hearth furnace and its production, and try to show some of the many factors in the process of manufacturing which have an influence on the corrosion of the finished products. To begin with, it is necessary that we have raw materials of good quality, pig iron, scrap and fluxes; the standard specifications of basic pig are suited for our requirements. Great care must be taken in the purchasing of scrap, as it requires but a small amount of impurities in the scrap to cause unlimited trouble in the finished product. Cast iron scrap of all kinds is to be avoided. Furnace operations are the next factor to be considered. The education of the men operating the open hearth furnaces is of the utmost importance and too many manufacturers are prone to allow men of inferior education to carry on this work and as a result thereof inferior products are made.

The proper regulation of the temperature of the furnace is a most important factor, influencing the quality of the product, and the ascertaining of the temperature with the eye, as it is customarily done is an uncertain proposition at the best. It takes a melter of long experience to determine accurately the temperature by those means and material which is needlessly overheated in open hearth furnaces, is injured beyond repair unless it is melted again with new fluxes and pig iron. After the metal has become thoroughly molten and

the temperature has been carefully watched, a sample is then taken from the bath and carefully analyzed before the material is removed from the furnace. The old methods of determining the amount of phosphorus and carbon in the metal by the visual appearance of a fractured test piece is being rapidly superseded by making preliminary chemical analyses before the material is tapped. Too much stress cannot be laid upon this point, if quality in the material is aimed at.

It requires but a short time to make determinations of carbon, manganese, sulphur and phosphorus, by our modern chemical methods and with this accurate information at his command the careful open hearth melter is able to make his heats to come within the range of the buyer's specifications. But even when these precautions are taken, many a heat is ruined by carelessness in tapping and handling the metal when in the ladle.

The melter must have before him the conditions to which the metal was subjected during the three or four hours previous to the tapping, together with the preliminary analyses to determine the necessary treatment in the ladle, as this is his last chance to add or detract from the quality of the metal.

But in aiming to make a quality product we must not neglect any step in the process. Many defects in steel can be traced to dirty molds or lack of care in pouring the molten metal therein.

When the ingot has been removed from the mold, it is usually placed in a reheating furnace or soaking pit before the ingot is cold. The heat of these pits should always be controlled by a pyrometer because the temperature must be regulated according to the chemical analysis of the metal. Much good material is ruined at this point for lack of knowledge as to its proper heat treatment. But at large plants chemists are working out these details and thus improving the quality and increasing the quantity.

We have now reached the stage of changing from a chem-



Paint That Holds the Wood Like a Driven Nail

SEASONED lumber is porous. The pores are the empty sap cells. White lead and linseed oil paint, which dries on the wood in the form of a solid, resinous film, fastens on its inner side into these pores and the whole coat of paint is actually *riveted* like armor plate to the property it decorates and protects.

The white lead must be pure and fine, and the linseed oil genuine, to form an inseparable compound which penetrates into these pores and anchors there.

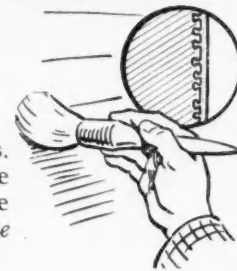

Dutch Boy White Lead

is guaranteed pure and is as fine as sifting through silk containing 28,000 meshes to the square inch can make it. Dutch Boy linseed oil is pressed from genuine flaxseed and comes in one and five-gallon cans sealed at the spout. These prime paint ingredients both bear the famous Dutch Boy Painter trademark—a symbol of purity—and make paint which dries to a tough, elastic, durable film that *holds to the wood like a driven nail*.

Dutch Boy white lead and linseed oil paint can be tinted any color, any finish can be obtained and it can be mixed to suit any surface, inside or outside.

You Should Have

a copy of our folder telling how to estimate the quantity of paint needed and giving 39 color combinations for exterior and interior work. Sent to any builder or architect together with specifications for painting wood, brick, cement, plaster and metal, for a two-cent stamp. Please write our nearest branch for Folders B.

NATIONAL LEAD COMPANY

New York Cincinnati Boston Cleveland
Buffalo St. Louis Chicago San Francisco
John T. Lewis & Bros. Co., Philadelphia
National Lead & Oil Co., Pittsburgh



You will get SPECIAL ATTENTION if you tell Advertisers you read American Carpenter and Builder.

A Golden Opportunity Awaits You

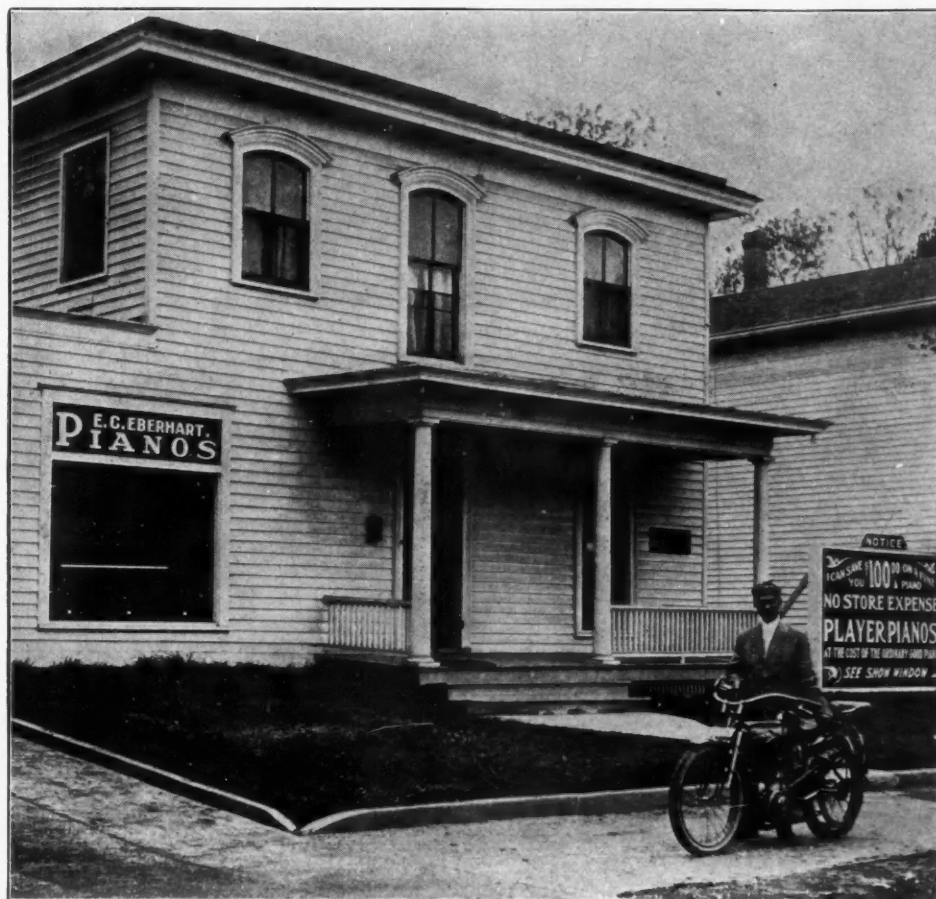

Every carpenter and builder should have a motorcycle. It will save you time, money, and a lot of other needless expense. There are hundreds of carpenters and builders, R. F. D. carriers, merchants and other people engaged in commercial lines who are saving money by riding Flying Merkel motorcycles.

We want one thousand new agents in territory unoccupied at present, and we believe that the carpenter and builder who rides a machine and covers a great deal of territory in his duties, is in a position to demonstrate the Flying Merkel advantageously. A number of carpenters and builders are already doubling their income by selling motorcycles in conjunction with their regular work.

If we have not an agent in your vicinity, write today for our liberal proposition, mentioning the American Carpenter and Builder.

The Flying Merkel motorcycle has long been known as the world's best motorcycle. It is the easiest motorcycle to ride, and the easiest motorcycle to sell. It is the easiest to ride, because of its patented spring frame and spring fork, which eliminates all road shocks and machine vibration, and also prolongs the life and utility of the engine itself. It is the only motorcycle in the world which operates by the dependable mechanical self-starter; its ball-bearing engine, low center of gravity and other features commend it at once to the critical motor buyer; it has won all the notable endurance runs and hill climbs of the country and a great many speed events, although we do not go in for races. The Flying Merkel is known as the most economical motorcycle in the world. It is the only motorcycle built with the Dual Braking System, which makes it again the safest motorcycle in the world.

We make five models, ranging in price from \$210.00 for a single-cylinder machine, equipped with folding foot boards, dual braking system, variable speed clutch and other features; the 7 H.P. twin-cylinder model, at \$225.00, and the famous Self-Starting "Yellow-Jacket" model, completely equipped at \$290.00.

This is no mail-order proposition. We have two large factories devoted exclusively to the manufacture of high-grade motorcycles and bicycles, and by doubling our production, we are able to extend the resources of our sales organization to hitherto unoccupied territory.

Hundreds are making money riding our bicycles and motorcycles. Why not you? Write today for free illustrated catalog and other advertising matter.

THE MIAMI CYCLE & MFG. CO.

Largest Manufacturers of High Grade Bicycles and Motorcycles in the World.

601 Hanover Street

Middletown, Ohio

You will get SPECIAL ATTENTION if you tell Advertisers you read American Carpenter and Builder.



Here's a Screen That Wears

—“PEARL” Requires no Paint or Repairs

You've been using painted screen—had to paint or repair it every spring. It lasts only a couple of seasons and at *best* is unsatisfactory.

This year make a change. Try Gilbert & Bennett PEARL Wire Cloth and learn just how *long lasting* and *handsome* a screen can be.

PEARL Wire Cloth is *durable* simply because it is practically *rust-proof*. And, as you know, rust ruins screens—*not* wear.

And as for appearance—well, the handsomest homes in America are equipped with Gilbert & Bennett PEARL, and it is distinctly ornamental—a decided contrast to ugly painted screens. You'll have to see “PEARL,” before you *fully* appreciate its beauty and worth.

GILBERT & BENNETT
PEARL
WIRE CLOTH

For Screening Porches, Windows and Doors

There's a weight of “PEARL” especially suited for your purposes. It comes in two grades—Regular for doors and windows and Extra Heavy, Extra Strong, for doors, windows and porches.

There is only one genuine PEARL Wire Cloth. That is made by Gilbert & Bennett. Don't accept galvanized or anything else as a substitute. Insist on seeing two Copper Wires in the Selvage and the Round Tag bearing our name on each roll and you'll be certain of getting the real article.

The best hardware dealer in your city sells Gilbert & Bennett PEARL Wire Cloth and will gladly supply you.

Or—write our nearest office and we will send samples, literature and the dealer's name.



**SAMPLES
FREE**

Write our nearest office

THE GILBERT & BENNETT MFG. CO.

(Established 1818)

Dept. C-277 Broadway, N. Y. Dept. C-38 So Dearborn St., Chicago
Georgetown, Conn. Kansas City, Mo.

ical to the physical treatment of the metal. From now on there is practically no change in the chemical composition, regardless of how often its physical form is changed. But we have learned that it is not alone the chemical analysis which makes a quality product, but the physical treatments it has received as well. The quest for new tonnage records has resulted in the too rapid fabrication of steel, thus producing strains and stresses which in their final adjustment to natural laws cause failure. The man in charge of the rolling operations must keep down the speed limit and this is true even for the rolling of sheets. After the sheets have been rolled, careful annealing at accurately determined temperatures is absolutely essential. We have now traced the process from the ore to the finished sheet, excepting only the protective coatings, put on to increase the life of the material. Let us outline now but briefly the theory and effects of corrosion, as this subject is too vast for a thorough discourse at this time. Corrosion or the rapid rusting of iron and steel may be considered as an effect of the combined action of water and oxygen or, in a broad sense, of moisture and air. Both air and water may contain elements which will stimulate or accelerate the corrosion.

The most widely accepted theory of the cause of this rapid rusting or corrosion, called the electrolytic, is based on the fact that when two substances, having different electrical potentials, are immersed in a suitable electrolyte, an electric current is set up and corrosion begins at once. In iron or steel the various impurities differ from the element iron in their electrical potentiality, and the moisture in the air contributes the electrolyte. It is also true that this action is of a chemical nature and that because of the very close connection between electrical and chemical action we are able to control this chemical action by stopping or accelerating the electrical action. Numerous investigators have been working for years along these lines and they have proven many facts heretofore in doubt to the great benefit of the iron and steel consumer. The purity of iron has a marked influence on the rapidity of corrosion; the quantity of the impurities must not only be very minute, but those few elements which it is impossible to remove entirely, must be absolutely homogeneously distributed.

Iron is more sensitive and has the power of varying its crystallization or form of structure in a greater degree than any other metal; and the manufacturers have learned that the whole art of producing quality, corrosion resistant metal consists of freeing it of impurities and producing the type of crystallization desired. Our constantly advancing knowledge of heat treatment and increased skill in the use of the pyrometer are making it possible to produce these quality products more and more uniform. Because of the extreme sensitivity of iron, great care must be used at its physical treatment or the work of having eliminated the impurities will be labor lost. The strains produced in rolling, unless removed by careful annealing, will generate active corrosion. These strains are caused by excessive speed in rolling or by extreme pressure on the material in breaking down.

The manufacturers of Toncan metal have spent years of research and thousands of dollars for the purpose of making a product which is safeguarded from the ore on carefully treated in every stage of manufacture and from which all objectionable impurities are eliminated to that minimum which their own investigations have proven to be best suited for a rust resistant, durable metal. And in addition they have made their plant a scientific institution, responsive to the requirements of a most sensitive material and prolonged the manufacturing process so that there will be ample time for every operation to be performed with scientific accuracy and thus a product results which represents a well-considered, honest effort to give mankind a serviceable material at a moderate price.

You will get SPECIAL ATTENTION if you tell Advertisers you read American Carpenter and Builder.

JOHNSON'S WOOD DYE

FOR THE ARTISTIC COLORING OF WOOD

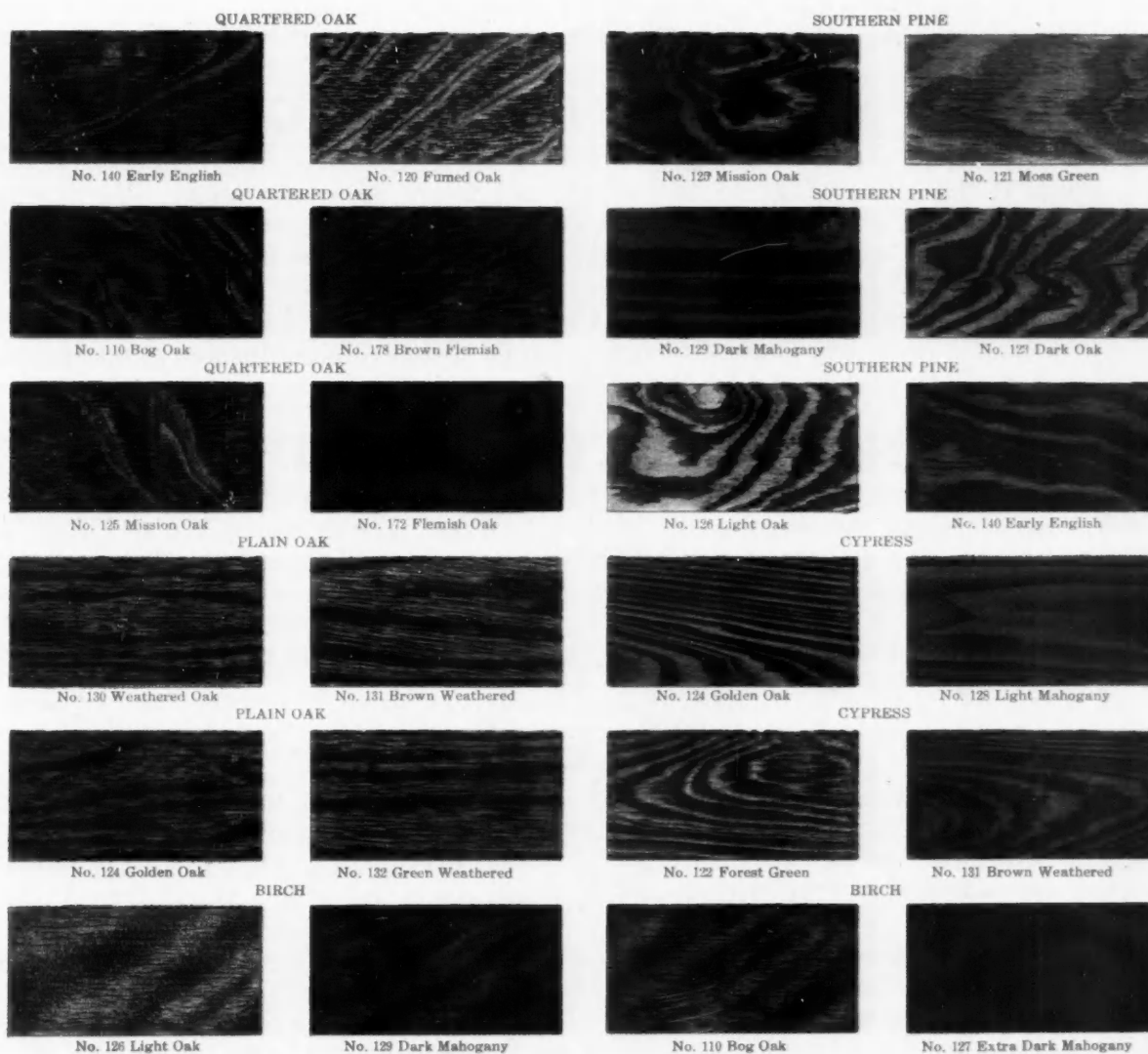

With Johnson's Wood Dye inexpensive soft woods may be finished so they are quite as beautiful as hardwood. It is a combination spirit—oil dye, possessing all the good qualities of both a spirit and an oil stain and the disadvantages of neither.

All shades of Johnson's Wood Dye may be lightened and darkened at will, or two or three shades can be mixed together; in this way hundreds of different effects may be produced.

Johnson's Wood Dye is very easy to use—simply apply with a soft brush upon the bare wood; it may be wiped or not, as preferred. Wiping with a cloth or waste gives a little lighter effect and also emphasizes the grain of the wood.

A few of the many advantages of Johnson's Wood Dye over oil stains are:

First. Johnson's Wood Dye penetrates deeply into the wood bringing out the color clearly and accentuating the grain without raising it in the slightest.

Second. Johnson's Wood Dye dries in ten or fifteen minutes so the finish can be applied. This makes it an easy matter to finish work quickly. Another advantage of this quick-drying quality is that it prevents dust and dirt from accumulating in the finish.

Third. Any kind of finish (except shellac) may be used directly over Johnson's Wood Dye. This applies to wax, varnish, oil, etc. With an oil stain a coat of shellac is necessary before any other finish can be applied.

Take advantage of the offer on the reverse side of this sheet and prove our claims.

JOHNSON'S PREPARED WAX

Johnson's Prepared Wax is the only proper finish for floors—soft and hard. It imparts a beautiful, rich, artistic finish which can be easily kept in perfect condition.

Johnson's Prepared Wax does not show scratches nor heel-marks. Neither does it give a slippery surface, so you will be perfectly safe in specifying it for floors and stairs used by children or old folks.

JOHNSON'S UNDER-LAC

Johnson's Under-Lac is a thin, elastic spirit-varnish, manufactured especially for use over Johnson's Wood Dye instead of shellac. It has many other uses also. We recommend it for finishing linoleum, oil-cloth, sanitas, etc.,—and also as a first coater under Wax or varnish—in fact, it can be used wherever shellac would ordinarily be used and with much better results.

Johnson's Under-Lac is easier to use than shellac because it does not dry as quickly. Any good workman can obtain perfect results with it. Johnson's Under-Lac dries in less than an hour so that wax or varnish may be applied.

JOHNSON'S FLAT WOOD FINISH

Johnson's Flat Wood Finish is the best flat varnish on the market. We recommend it highly for woodwork and furniture over Johnson's Wood Dye or Paste Wood Filler. Apply with a brush—it will dry in four or five hours, giving a beautiful, artistic finish closely resembling the hand-rubbed. Only one coat is necessary.

Johnson's Flat Wood Finish presents wonderful opportunities for the contractor—you can now give your customers a beautiful, durable finish with the up-to-date flat effect at one-third the cost of the labor on a hand-rubbed job.

FREE OFFER

In order to give leading contractors an opportunity to test the merit of Johnson's Wood Finishes we attach herewith a certificate which is worth \$1.10 in merchandise. Cut it off, fill in your name after the words "furnish gratis to" and present it to your dealer in paints. He will furnish you **absolutely free** with half-pint packages of Johnson's Wood Dye, Under-Lac and Flat Wood Finish.

Johnson's Wood Finishes are particularly adapted to the needs of contractors and builders—All of our products dry quickly so that work can be finished in the minimum space of time—any good workman can use them with perfect results—the price is right—there is no variation. Johnson's Wood Dye is put up in glass bottles so there is no possibility of chemical changes such as occur in stains put up in tin.

Take advantage of this offer and prove our claims. *Do it now!!!*

S. C. Johnson & Son

"The Wood Finishing Authorities"

Racine, Wisconsin

Notice to Dealer
Have recipient of half-pint packages
sign here - return certificate to us and
we will reimburse you at your cost.

\$1.10

S-C JOHNSON & SON

\$1.10

Racine, Wis.

Upon presentation of this certificate please furnish gratis

to

½ PINT JOHNSON'S WOOD DYE (DESIRED SHADE)

½ PINT JOHNSON'S UNDER-LAC

½ PINT JOHNSON'S FLAT WOOD FINISH

1-25¢ BOOK "THE PROPER TREATMENT FOR FLOORS WOODWORK & FURNITURE"

S-C JOHNSON & SON

TO YOUR LEADING
PAINT DEALER

BY

Robert L. Johnson
JR. PARTNER

A Big Show Assured

With the business situation clearing after the holidays, the affairs of the Forest Products Exposition are shaping themselves definitely and with reports at the headquarters in Chicago from all sections of the country and branches of the wood industry of America, direct and affiliated, there is every indication that the undertaking will prove even more productive of results than hoped for in the original calculations. The principal lumber associations and affiliated organizations have practically determined on a more or less extensive representation and participation, various trade organizations are planning, not only representation in the way of exhibits, but attendance in a body. A large number of concerns and individuals have signified their intention of taking space and showing their products.

According to advice received at the Chicago headquarters, the exhibits of the lumber and allied associations alone will provide one of the most interesting and instructive displays ever arranged for an industrial exhibit in this country. It has practically been decided that the United States Forestry Service will display a number of most instructive incidentals to the service, including fire tower, equipment station, timber-sale models, erosion models, relief map, mine timbers, greenhouse benchboards, collection of scientific instruments, national forest model, wood utilization exhibit, wood distillation exhibit, paper pulp exhibit, timber testing exhibit, wood preservation exhibit, specimens of wood waste products manufactured from such waste and bromides, transparencies, maps and charts. It is understood that some of the state forestry divisions will make similar, yet unlike, exhibits.

As several of the leading woodworking machinery manufacturers have indicated their intention of installing exhibits, with wood manufacturing plants being represented and any number of accessories having exhibits, a complete demonstration of the utility and possibilities of wood in all its phases is assured.



Stamped Steel Hardware

Small hardware fixtures, such as are used on windows, storm sash, screens, etc., have been cheapened and improved since the advent of stamped or pressed steel. Nowadays, a series of automatic machines turns out thousands of perfectly fashioned little items of builders' hardware made of wrought steel.

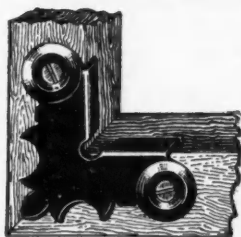

Steel Corner Brace

These are strong and tough, not easily broken like the old style cast-iron fixtures. Contractors and builders enjoy the benefit of this improvement. Many of these little hardware items now obtainable at a few pennies each, our fathers had to worry along without.

One of the most ingenious and tireless of the stamped-steel hardware concerns is the Watrous Manufacturing Company, Des Moines, Iowa. We have just been looking over one of their catalogs, and extremely worth while we have found it. Storm sash hangers and window screen hangers of several different types are illustrated. There are also adjustable sash fixtures, window catches, automatic door catches, etc.

One item that seems especially useful just at this time of year is the wrought steel corner brace for screen window frames. You will see at once how this brace, smoothly fastened by two screws, will make a light mitre joint that won't give nor break loose.

All users of builders' hardware and all who make or repair screens should write for this interesting catalog and investigate the screen sash corner braces, as well as their other offerings.

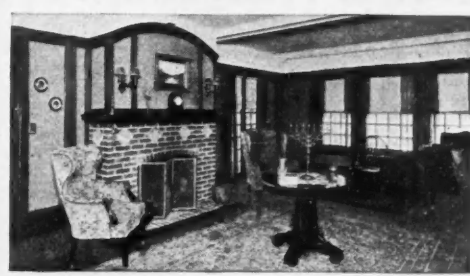

Living Room of Residence of W. H. Johnson, Garden City, L. I. Finished with Bridgeport Standard Wood Finishing Products. Alfred Busselle, Architect; Van Name & Co., Contractors.

YOU can have the most beautiful woodwork in your home by using

Bridgeport Standard Wood-Finishing Products

Ask for our "Modern Wood Finishing"—a beautifully illustrated book showing all of the popular finishes in their actual colors and giving a complete treatise on the art of modern wood finishing. Simply write your name and address on the margin of this ad and mail it to us.

It is the opinion of leading architects, decorators, painters and contractors that *Bridgeport Standard Wood Finishing Products* bring out the natural markings of the grain and figure of all kinds of wood better than any other materials; also that they are more durable and more practical; further, that they are *more economical*—measured by the *much better* results and the many years of additional service they give.

SOLE MANUFACTURERS
THE BRIDGEPORT CO.
WOOD FINISHING
NEW MILFORD, CONN., U.S.A.

Box 105. NEW YORK CHICAGO BOSTON

You will get SPECIAL ATTENTION if you tell Advertisers you read American Carpenter and Builder.

Myer's Poster Calendar

1914 has brought its large interesting calendar from F. E. Myers & Brother, Ashland, Ohio—the Poster Calendar that has become a familiar sight for years in dealers' offices all over the country.

On this calendar they illustrate their entire factory products—pumps of all kinds, hay unloaders, pulleys, door hangers, etc. You have to "take off your hat" to the Myers when it comes to any of the goods in their line.



Coltrin Concrete and Mortar Mixers

Their 1914 catalog is just being distributed by the Knickerbocker Company, Jackson, Mich. This is the most elaborate and best illustrated book these people have ever issued. Everything is arranged in the most logical order, and no pains have been spared to give the inquiring reader every particle of information he could possibly want about the Coltrin machines.

It has been said that words were made to conceal thoughts, and we sometimes think, looking over some of the building trade catalogs that reach us, that this is indeed the case. There are words there all right; many of them. But after going through them you have no more idea than at first of what the machine is, how it operates or what it is guaranteed to do.

Not so, however, with this catalog from the Knickerbocker Company. Studying its pages is just like talking with Mr. Knickerbocker. We do it every year at the Cement Show. Everything is straightforward; nothing concealed or ambiguous. Some strong claims are made for the Coltrin, but when we see them set down in black and white in this catalog or hear them advanced by the responsible men of the Knickerbocker Company, we know there is good and ample foundation for them.

A great variety of types and sizes of Coltrin concrete and mortar mixers are featured in this new catalog. They range in size from 900 pounds in weight, hand power, up to 4,500 pounds, 8 hp.

A very interesting section of the catalog is devoted to photographs of construction work, showing Coltrin mixers in use. Every reader of the AMERICAN CARPENTER AND BUILDER should have a copy of this 1914 catalog. The manufacturers, the Knickerbocker Company, Jackson, Mich., will gladly send copies free to those writing them.



Advice to Skidders

"Carelessness and fright are the two big factors in most bad skidding accidents," says R. D. Jones of the KisselKar. "When the streets are slippery the best of drivers will have their troubles unless they use caution.

"And the first rule of caution, I would say, is to drive so that the sudden application of brakes will not be necessary at any time. For when the brakes go on hard and suddenly, there is going to be an automobile doing a tango immediately.

"I warn all beginners—and some older drivers too—to approach all street crossings with the car under control without the brakes being used. Let the engine do the braking to slow up for a crossing. Then put on the brakes easily. If the car shows a tendency to swing around release the brakes immediately.

"And then here is the one big vital thing to do. Turn the front wheels in the direction to which the rear of the machine is skidding. It is instinct to turn the wheels in the opposite direction. The result is that the skid is accentuated.

"When driving along the road and there is trouble on the right side it is instinct to turn the wheels away from it. That is the reason the beginner will invariably make a skid worse."

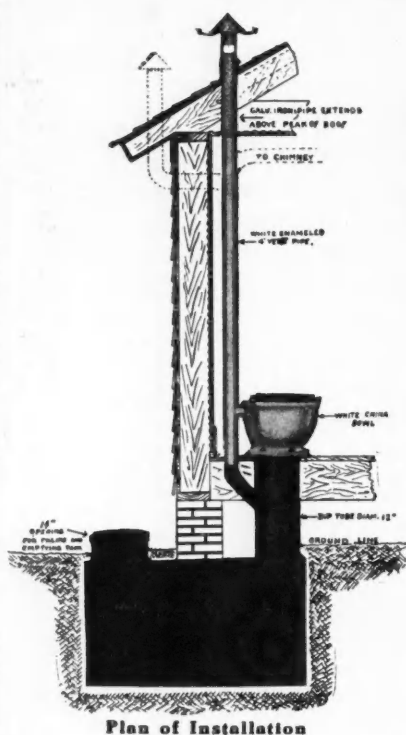

Plan of Installation

The Sanitary, Chemical Closet System

A modern system, requiring no water and no sewer connection. Indispensable for any home, school, factory, store, church, park, railway or public comfort station or any place where sewerage facilities are not available.

Abolishes the outside open closet vault or cesspool and the attendant discomfort and disease danger. Can be installed inside or outside. Looks like the ordinary sewer water closet, but requires no water or sewer.

Requires only thirty minutes attention twice a year. Installation costs one-third that of any flush water system. Chemical used in operation costs less than water. Approved by leading sanitary and health authorities.

Guaranteed in Every Way

Special proposition installing first system in any locality. Complete systems cost from \$25.00 to \$50.00. **Booklet free.** Please state requirements.

Agents Wanted. Please State Experience, etc.

Sanitary Chemical Closet Co., Dept. D, Bradford, Pa.

You will get SPECIAL ATTENTION if you tell Advertisers you read American Carpenter and Builder.



Building for Mr. J. G. Keidel, Trimmed with

MIDLAND STOCK TERRA COTTA "The Usable Kind"

Our Catalogue is a Mine of Useful Information
Write for It

MIDLAND TERRA COTTA COMPANY

1121 Chamber of Commerce

CHICAGO, ILLINOIS

You will get SPECIAL ATTENTION if you tell Advertisers you read American Carpenter and Builder.

The Diamond Flexible Metal Weather Strips

Contractors! Builders and Carpenters

The installation of weather strips legitimately belongs to you—you can install them with your regular men with the instructions we give you. There is no mystery about it. It is simple. Why not get this profit yourselves, instead of giving it to the other fellow? You can handle it along with your business without any additional expense. We have some mighty good territory still open.

*We make a full line of Weather Stripping
for all kinds of Doors and Windows*

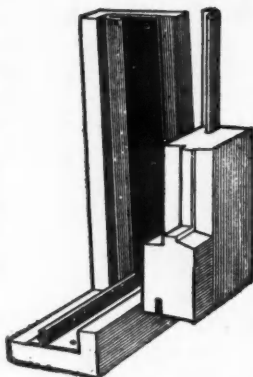

Section Showing Removal of Sash and "Flexible" Strip at the same time.

"The Diamond Way" of PRACTICAL Weather Stripping

Meets all requirements
of Modern Construction

Made of zinc or highest
grade spring bronze—never
rusts—can be put in old as
well as new buildings.

GUARANTEED 10 YEARS

They make all openings air-tight—hence, wind, dust, moisture or noise cannot enter. The fuel saving in buildings where the Flexible Metal Weather Strips are used, has averaged from 20% to 40%. Flexible Metal Weather Strips are beyond comparison for their adaptability to houses, hospitals, schools, churches, etc. Their great advantage over all other weather strips, together with their moderate cost make it a simple matter to specify them or to sell them.

Send for Catalog of Details.

We supply you with a complete outfit such as Models, Printed Matter—Contracts, Estimate Sheets, etc.

WRITE, TODAY, NOW

For Full Particular

OUR AGENTS KEEP BUSY THE YEAR ROUND

THE

Diamond Metal Stamping Co.

626 Kerr Street

..

COLUMBUS, OHIO

Buzz-Saw Number of "The Philistine"

Whether Elbert Hubbard writes of men or morals he is sure to be interesting.

Simonds Guide for Millmen for January, took the form of this special number of "The Philistine." The Guide as it usually appears is no slouch, and has both entertained and instructed its readers in times past. This Buzz-Saw number, by the Fra, adds a strong dash of pepper to season the year's output.

Right on the first page Elbert breaks out with his irrepressible story-telling.

"To saw wood," he says, "is an injunction and a proposition that is familiar to all of us, but one that is open to varied interpretations."

"'Can you saw wood?' asked the lady of the tramp, who applied at the back door for a hand-me-out.

"'Madam,' said the hobo, who was from Boston, 'you will pardon me if I correct your ungrammatical construction. You should not say, 'Can I saw wood?' You should express it thus: 'Can I see wood?'"

From gay to grave is one of the specialties of this literary comedian. There is a ring of genuineness and truth in it when he says farther on, referring to Abel Simonds, who founded the present business of Simonds & Company away back in 1832: "Stradivarius made violins to the glory of God. Simonds makes saws, inspired with a like purpose."

AMERICAN CARPENTER AND BUILDER readers are well acquainted with Simonds saws. Many of them will probably be glad to know more about the Simonds Manufacturing Company; of its personnel, factories, etc. We presume extra copies of this Buzz-Saw number of "The Philistine" can be had by writing the company at their main office, Fitchburg, Mass.



New Trus-Con Waterproofing Hand Book

We have received a copy of the new complete edition of Waterproofing Hand Book just issued by the Trus-Con Laboratories. This is the most comprehensive publication on Waterproofings, Dampproofings and Technical Paints ever issued by these people. In it there is a large amount of new scientific information appearing here for the first time.

The Trus-Con Hand Book clearly differentiates between various methods of waterproofing and dampproofing, showing the best methods of treatment for specific conditions. Integral waterproofing is covered fully with numerous specifications and directions, explaining clearly how mass concrete can be absolutely waterproofed.

The various methods of dampproofing exposed surfaces of concrete, stucco, brick and masonry are discussed, and various products indicated to insure the most satisfactory results. The troublesome problem of treating concrete floors which have become dusty is brought up, and the remedy suggested. Sanitary, washable interior finishes are indicated, both for residential and business buildings. The protection of structural steel is scientifically treated and materials indicated, to provide against various exposures.

In short, the Trus-Con Hand Book is a scientific publication, which will prove useful to any of our readers that are interested in problems of waterproofing, dampproofings of technical paints. A free copy of the Trus-Con Waterproofing Hand Book will be forwarded by the Trussed Concrete Steel Co., Detroit, Mich., to any reader of the AMERICAN CARPENTER AND BUILDER who will write for one.

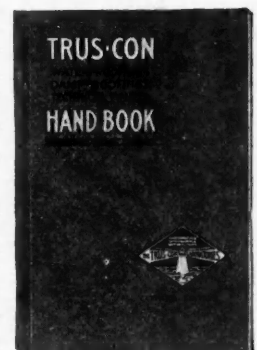

You will get SPECIAL ATTENTION if you tell Advertisers you read American Carpenter and Builder.

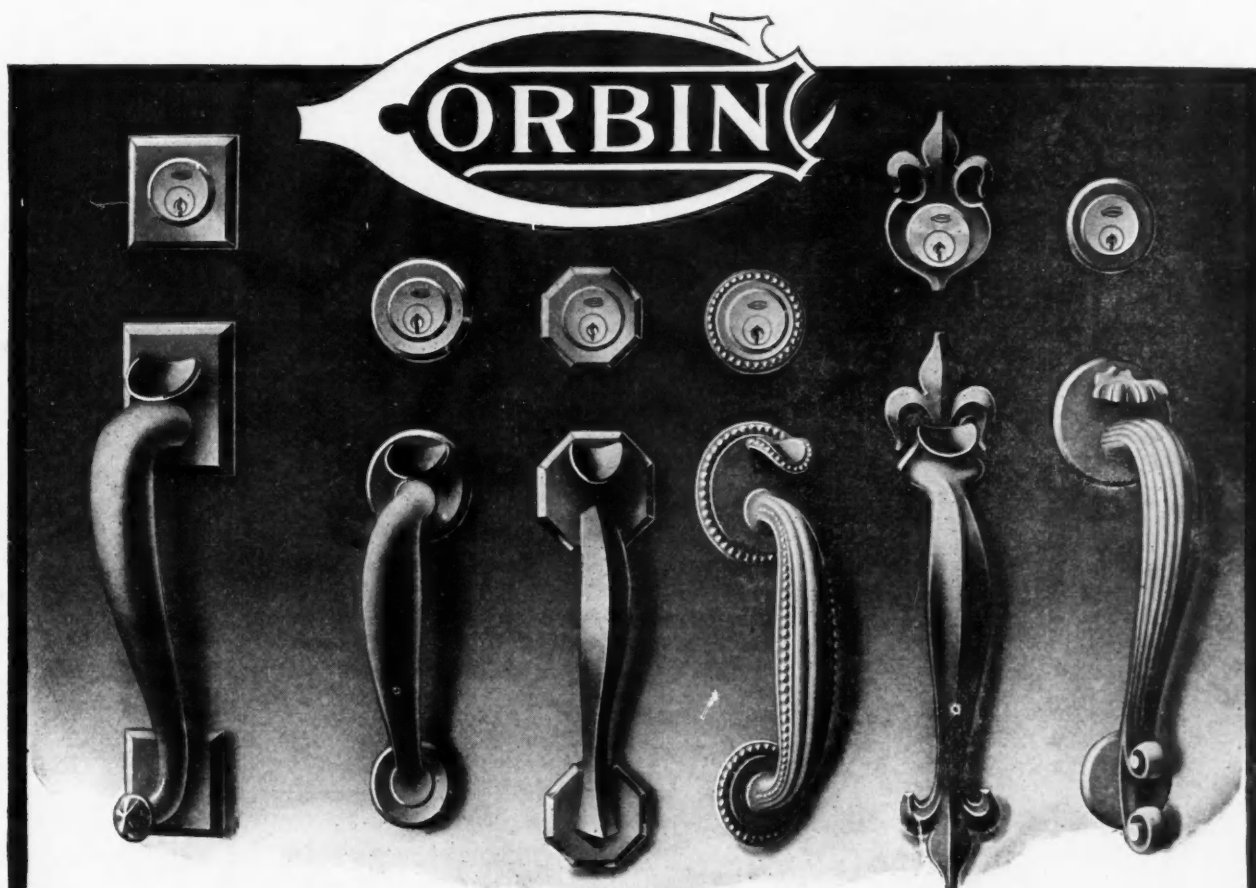

CORBIN DOOR HANDLES

For use with Corbin high grade locks with modern functions and high in popular favor for entrance doors of fine homes. A few of the simpler forms are shown. Circular CK 82 lists and describes our full line. Send for it.

P. & F. CORBIN

Division

The American Hardware Corporation

NEW BRITAIN, CONNECTICUT

P. & F. Corbin of Chicago

P. & F. Corbin of New York

P. & F. Corbin Division, Philadelphia

You will get SPECIAL ATTENTION if you tell Advertisers you read American Carpenter and Builder.

"White"—Remember the Name

The L. & I. J. White Company, 10 Columbia Street, Buffalo, N. Y., have had seventy-six years' experience manufacturing high-grade edge tools. Away back in 1837 they began in a little two-story frame building. Today their huge four-story modern factory building is one of the most complete in the city of Buffalo. Throughout all this time the principles of manufacturing have been rigidly held to—quality goods always, each piece inspected, tested and guaranteed.

The carpenter is the man who knows a good tool when he tries it. The L. & I. J. White Company want you to try one of theirs. They say the next time you need a chisel or a draw knife, or a hand axe, or any other edge tool they want you to try one of theirs.

Drop a card to these people now, giving your dealer's name. They will send him their big general catalog, which shows all their tools and prices, and then when you are ready to order there will be no delay.



Beach Combination Rip and Cut-Off Saw

In designing this tool the aim of the Beach Mfg. Co. has been to furnish a thoroughly efficient combination machine at a reasonable price. We believe that they have succeeded and submit as evidence of the fact the following specifications:

The table is mounted on anti-friction rollers and is shown in the illustration arranged for cross-cutting. When ripping is to be done it may be locked to the frame by means of the lever shown at the left side of the machine. A removable throat 5 inches wide, extending the whole length of the table, is provided to admit of using dado heads.

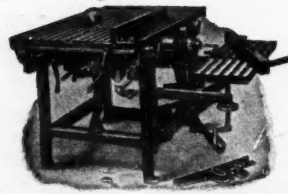

Beach Mfg. Co. Combined Saw Table and Borer

The arbor is steel, having connected, self-oiling boxes, with the pulley between them. Oil chambers, placed in each end of the boxes, are connected by wicks extending the whole length of the journals. These supply oil to all parts of the bearings and any excess is collected by the chambers at the ends as it is torced out.

The arbor yoke is carried on a frame journaled at the back of the main frame and supported at the front of the machine by the adjusting screw and hand wheel shown in the illustration. To render this support very rigid and unyielding when the saw is in position for use, a planed surface on the raising and lowering frame is clamped securely against a similar surface on the slotted guide at the front of the machine, by an eccentric lever.

The frame is either iron or wood as may be preferred. The iron frame is cast in one piece and is very stiff and well braced. The wood frame is made of hard maple or black birch, securely bolted at every joint.

The boring attachment is entirely independent of the saw table and is driven by a separate pulley on the countershaft. The arbor is fitted with a 1/2-inch hole, and has a horizontal movement of 6 inches.

With each machine is included countershaft complete, rip saw, cut-off saw, arbor wrench, ripping gauge, cut-off gauge and miter gauge.

For further information address the Beach Mfg. Co., Montrose, Pa.

Most Municipalities Prohibit The Use of Wooden Shingles

because of fire risk and the proven fact that *there is a fireproof shingle* which combines the lightness of wooden shingles with the lasting qualities and attractiveness of slate, and is withal reasonable in first cost and maintenance.



Baraga High School, Baraga, Mich., Covered with J-M Transite Asbestos Shingles

JM Transite Asbestos Shingles

fulfill all these requirements. These shingles are composed of pure, long-fibered asbestos and the finest grade of Portland Cement (both minerals) molded into a solid mass.

They are fireproof, weatherproof, never decay, warp or break, and never need painting or attention after being laid. Furnished 3/8" thick with smooth edges, in colors of gray, Indian red and slate; and 1/4" thick with rough edges, in gray and Indian red.

Write for Samples, Booklet and Prices

H. W. JOHNS-MANVILLE CO.

Manufacturers of Asbestos Shingles, Roofings Stucco, Pipe Coverings, Cold Storage Insulation, Waterproofing, Sanitary Specialties, Acoustical Correction, Cork Tiling, Fireproof Doors, etc.

Akron	Boston	Cleveland	Detroit	Indianapolis	Milwaukee	Omaha	St. Louis	Syracuse
Albany	Buffalo	Columbus	Duluth	Kansas City	Minneapolis	Philadelphia	St. Paul	Toledo
Atlanta	Charlotte	Dallas	Galveston	Los Angeles	Newark, N. J.	Pittsburgh	Salt Lake City	Washington
Baltimore	Chicago	Dayton	Houghton	Louisville	New Orleans	Portland, Ore.	San Francisco	Wilkes-Barre
Birmingham	Cincinnati	Denver	Houston	Memphis	New York	Rochester	Seattle	Youngstown

THE CANADIAN H. W. JOHNS-MANVILLE CO., LIMITED, Toronto, Montreal, Winnipeg, Vancouver. 1740

You will get SPECIAL ATTENTION if you tell Advertisers you read American Carpenter and Builder.



Your clients associate on very intimate terms with the Interior Trim of the houses you build.

ARKANSAS SOFT PINE

is a good companion.

It is not complicated enough to tire.

It has not a plain surface that will weary.

It will fit any personality for it is susceptible to all manner of treatment and with it all wood effects are possible.

First Cost is light, much below the cost of other trim woods, and there is no subsequent cost for "upkeep."

It will stand the wear.

It will hold the finish you give it.

If you are interested in this subject send for a copy of our Interior Trim book. It will show you how to make additional profits and to please your customers.

It tells *why* Arkansas Soft Pine is the Trim you should use.

Arkansas Soft Pine Bureau, - Chicago, Ill.
308 SOUTH CANAL STREET

You will get SPECIAL ATTENTION if you tell Advertisers you read American Carpenter and Builder.

UTILITY WALL BOARD



THE OWNER OF THIS BEAUTIFUL HOUSE SAYS:

"Utility Board was a great saving in the construction of the house and enabled us to move into the house at least four months sooner than we otherwise would have done." Yours truly,

BEACH & FULLER CO.
(Signed) R. B. Fuller, Secy. & Treas.

Profits for You the Year Round

There is no such thing as a dull season for the wide-awake builder who handles Utility Wall Board.

UTILITY WALL BOARD

No competition, pleased customers, good profits—that is what Utility Wall Board means to you.

Write for Sample

THE HEPPE'S COMPANY

Also Manufacturers of Flex-A-Tile
Asphalt Shingles, Asphalt Roofing
in any Finish and Asphalt Paint

4503 Fillmore Street
CHICAGO

Mixers for Quick Delivery

To those of our readers located in the Western part of the country, it will be of more than passing interest to learn of a report from the Lansing Company, 708 Cedar St., Lansing, Mich., of several recent carload shipments of the 1914 model "Broncho" Batch Mixers to Seattle and Tacoma, Wash., and Portland, Ore. Contractors located out in that section will now be able to get deliveries from any one of these three points, which gives them the benefit of carload rates—an item that every man will appreciate—and the further advantage of quick deliveries.

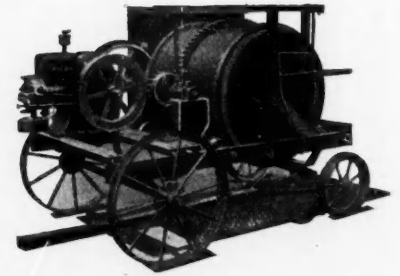

"Broncho" Batch Mixer. 1914 Model

If there is any one thing that is annoying to a contractor when he has a hurry-up job on his hands, it is the matter of slow shipments and deliveries; and it is with a full appreciation of that fact that the Lansing Company have decided that they can serve their Western customers better by having stocks of mixers more easily available.

They claim some very marked improvements in this year's model over the machine sold last year—added strength in the frame; a more rapid discharging device; full-circle swing for the front wheels; and a larger, more powerful engine.

Those interested should write to the Lansing Company for the latest literature on this machine, and secure the nearest address where these machines are carried. Machines are now in stock in more than thirty cities outside of Lansing.



Estimating Bad and Good

Slipshod estimating and guess work has ruined many a good man. A builder is anxious to get a piece of work and may have inside information that his efforts will be fruitful, but even so, he is liable to overlook something or many things. His familiarity with a particular class of work makes him over-confident. He sends in his tender and is accepted. Perhaps his was not the lowest, but he honestly believed that he gave a fair, reasonable offer to do the work with a marginal profit. When the work commences and as it advances he discovers that he overlooked the ceiling joists, or didn't reckon on the strapping, or some other items. If only one item be omitted, however small, he is that much the loser. "But," he may say, "what does it matter? I have allowed sufficient elsewhere to cover that." Thus he cuts a piece off the top of his pants to make them longer at the bottom.

No man can be a success until he can make a reliable estimate of the actual cost of everything required in the job and do it quickly. Then, and then only, can he tell how much he will gain, and only a systematic method will enable him to do this, and place him in a position to do good work to the satisfaction of the owner, the architect and all concerned. He then impresses the architect with his sincerity and ability, increases his clientele, and improves his banking account, building up a reputation and obtaining a lasting advertisement which cannot be secured by any other means.

Rapidity doesn't mean so much in making an estimate; but it gives the builder more time for looking after his business.

The Bradt Publishing Company emphasize these facts in their ad. this month and offer a solution of these problems to those sending for the last edition of the Lightning Estimator.

You will get SPECIAL ATTENTION if you tell Advertisers you read American Carpenter and Builder.

BEAVER BOARD

Making the Best Better

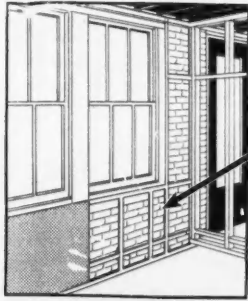

OVER BRICK
Furring strips furnish nailing surfaces for all edges of panels.

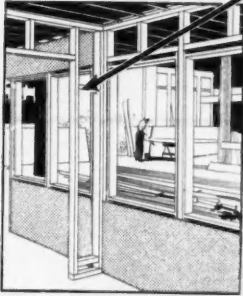

INSIDE WALLS
Headers should be placed where needed for nailing top and bottom of panels, top of baseboard, etc.

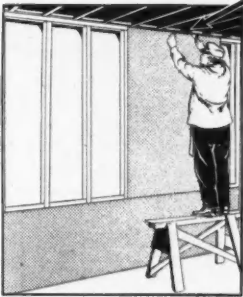

PLACING PANEL
First nail top center to hold in place. Continue as in next picture.

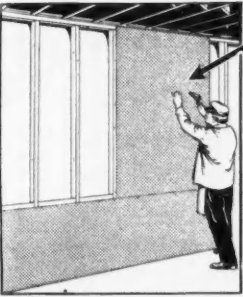

NAILING CENTER
Always nail to intermediate studding, before nailing edges. Use fine wire brads.

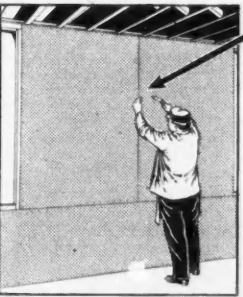

NAILING EDGES
Smoothout panels, then nail edges with flat-head nails, 3 inches apart



SAWING
Use a fine, panel saw, as for any fine lumber, pebbled side of panel up.

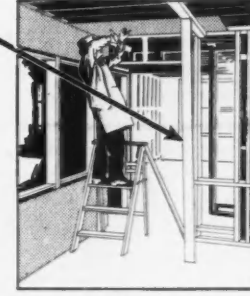

CEILINGS
Note support at right to hold loose end of panel in place.

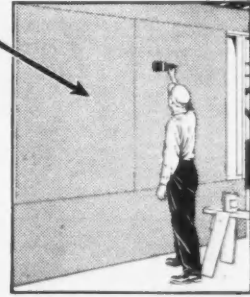

PAINTING
This should be done before strips are put over edges of panels.

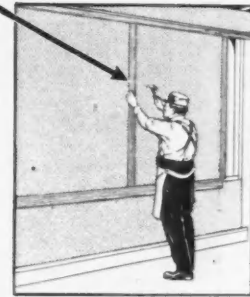

FINISHING
Decorative strips are stained (or primed) before they are nailed over edges.

BEAVER BOARD was already best when it was first put on sale in 1906. Its growth since then—impossible without good quality—tells the story. Eighteen hundred per cent increase in annual sales since 1910.

Sold in bundles in 1906—by trainloads to-day. Two distributors and seven dealers in 1910. Two hundred and fifty distributors and eight thousand dealers in 1914.

BEAVER BOARD has been a solid, substantial success, based on quality.

Eight years of study, research and investigation have produced a still better BEAVER BOARD.

This year BEAVER BOARD is even more durable, more beautiful in its pebbled surface, more resistant to heat and cold, more proof against every influence of climate and temperature.

But we can't do everything. We can supply the best material made for walls and ceilings, we can give you a new opportunity for high-class work; but *you do the work*. It's easy to put up, but it must be put up right to get the finest results.

Fill out the coupon and we'll send you a free, painted sample of the new BEAVER BOARD and put your name on the mailing-list of our Carpenters' and Decorators' Co-operative Department. No obligation on your part, but you get all reading matter issued by the Department.

BEAVER BOARD is sold by 8000 Builders' Supply, Lumber and Hardware Dealers in sizes to meet your needs. Look for trade-mark on back of each panel and make sure of GENUINE BEAVER BOARD and the co-operative service you get with it.

THE BEAVER BOARD COMPANIES

United States: 329 Beaver Road, Buffalo, N. Y.
Canada: 529 Wall St., Beaverdale, Ottawa.
Great Britain: 4 Southampton Row, London, W. C.



A FINE JOB
Designing and workmanship are equally good in this living room in the home of W. H. Marshall, Geiger, Ohio.

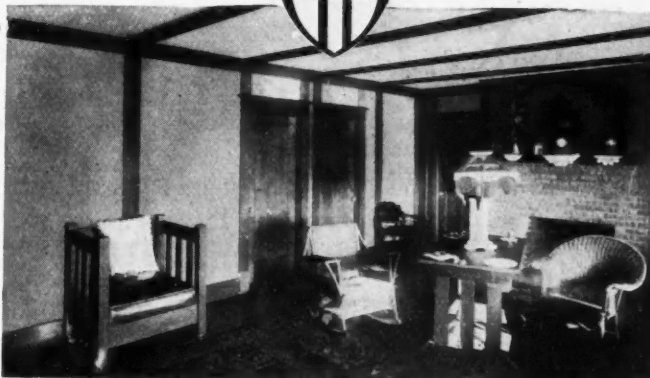

Please put me on permanent mailing list to receive all reading matter issued by Carpenters' and Decorators' Co-operative Department.

Name

St. Address

Town

State

You will get SPECIAL ATTENTION if you tell Advertisers you read American Carpenter and Builder.

All Hands Write Alike on the Bennett Typewriter

The progressive contractor and builder is ever on the alert for new business and he is fast adopting methods that have won out in other lines.

The mailing list of many concerns is worth thousands of dollars to them. The contractor and builder will find also that with the aid of the Bennett Portable Typewriter he can easily work up a mailing list of prospective customers that will keep a continuous stream of new business coming his way.

When a contractor or builder learns of people who are contemplating building he should at once lay before them the reasons why he should be given the job—and the most effective way to do this is by sending out typewritten letters. You can talk to a man about the superiority of your work until you are exhausted and then when it comes time for letting the contract he will forget most of the things you said. Not so, however, with a letter. He has every one of your arguments before him in black and white, knows just exactly what you will do, how long it will take you to do it, and how much it will cost, including your fee. Verbal estimates and bills should always be confirmed by letter.

All hands write alike on the typewriter, and no one need be handicapped by his penmanship. A longhand letter never gets the same attention as a typewritten one—it requires longer to write and it is impossible to make at the same time, comes for reference.

The attention of our readers is particularly called to the Bennett Typewriter, illustrated on another page. This is a portable machine that a contractor or builder can carry right with him and do his office work wherever he is. It has the standard 84-character keyboard, reversible ribbon,

marginal release and the writing is always in sight. And yet this typewriter is very moderate in price. Write Chas. A. Bennett Co., 3301 Cedar St., Harrisburg, Pa., for particulars regarding their remarkable typewriter.



The Fox "Junior" Floor Scraper

The Fox Supply Co. of Brooklyn, Wis., have just placed on the market a new floor scraper, at what they claim is the lowest price yet made on a practical floor scraper. This they call the Fox Junior. It is a simple, economical contrivance which scrapes a floor satisfactorily. It is designed for the use of carpenters who do not have a great deal of floor work to do and, therefore, do not wish to invest in a higher priced machine.

Hand scraping is such an expensive operation that the Fox Junior will prove its



worth many times over. It not only scrapes faster, but does better work than can be done by hand. The body of the scraper slides on the floor like a plane, insuring a cut of uniform depth. It works equally well on all kinds of hardwood flooring, including Georgia pine. It is particularly well adapted to the smoothing of old floors. It is guaranteed not to jump or leave waves. A rubber cushion over the knives prevents chattering.

If You are a Worker in Wood, whether in the Factory or in the School-room, You will be interested in

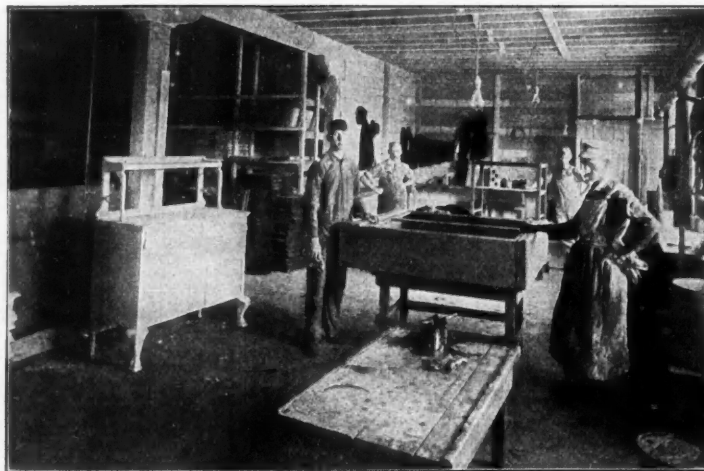

"Cabinet-Making"

"Cabinet-Making"

By J. H. RUDD

A book written for the practical cabinet-maker, in a practical way. "Cabinet-Making" is not a treatise for beginners, but it will prove as adaptable to the student in the manual training class-room as to the factory worker. Its terse, free style is unburdened with technicalities and offers solutions of your own problems that you can apply in your own way.

Sent Post-Paid on Receipt of \$1.50.

American Carpenter and Builder

1827 Prairie Avenue

Chicago, Illinois

You will get SPECIAL ATTENTION if you tell Advertisers you read American Carpenter and Builder.

Every Carpenter and Contractor Should Have these Four Machines

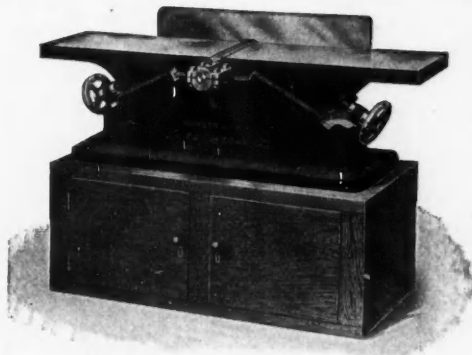

No. 254. Bench Hand Planer

- they form the foundation for a money making shop and mill equipment.
- in the beginning, they well take care of all the work you will have.
- as your business in this line grows, you can add such units as you need.

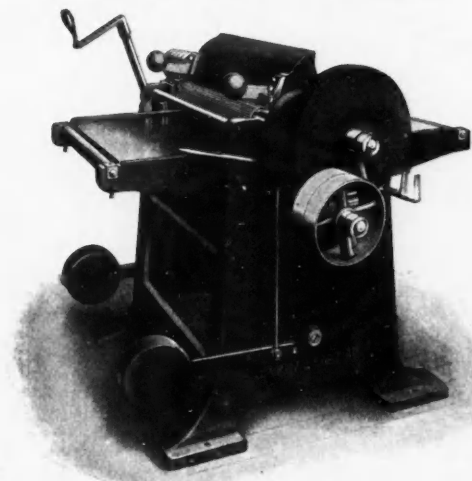

No. 2. Centennial Surfacer

These four machines take up little space—can be driven by a small motor or gasoline engine; easy to operate; built on high-duty machine-tool principles insuring low operating and upkeep cost and freedom from annoying breakdowns and repair bills.

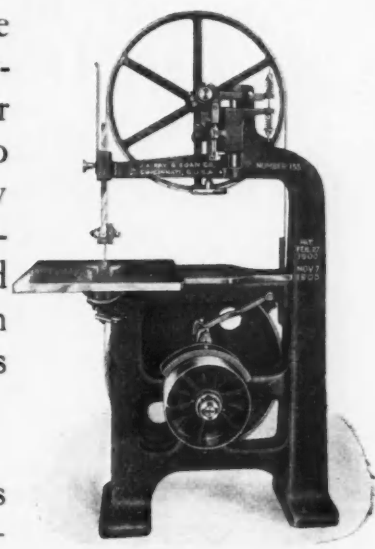

No. 155. 30 in. Band Saw

You know the advantages of having your own shop—you have read of the money other subscribers to the American Carpenter & Builder are making by doing their own mill work—get into the game yourself. But start in right. Buy practical machines and build up from the bottom, just like you put up a house. Our special catalog of small shop tools illustrates and describes these and other machines for you in detail.

Write for it—it's free.

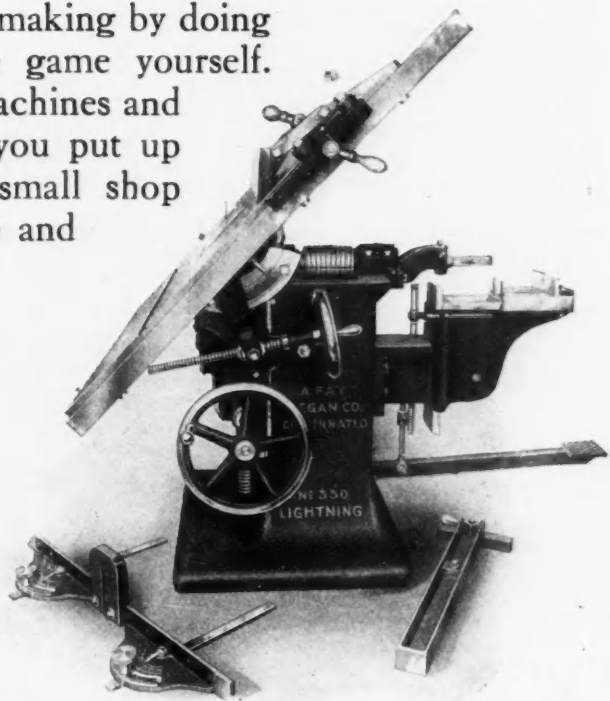

No. 330. Variety Saw
With Hollow Chisel Mortising and Boring Attachments

J. A. Fay & Egan Co.
545-565 W. Front Street
CINCINNATI, O.

You will get SPECIAL ATTENTION if you tell Advertisers you read American Carpenter and Builder.

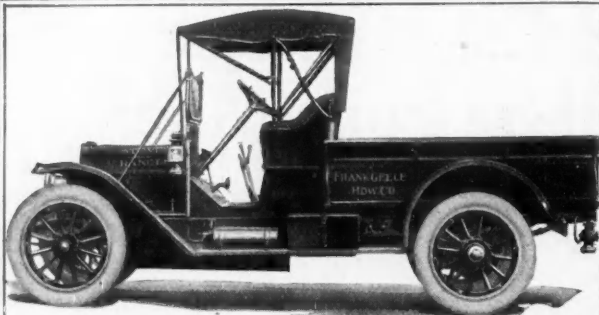

KesselKar Motor Wagon Operated by
Frank Geile Hardware Co., Milwaukee, Wis.

Service is written into the sale of KesselKar Trucks

When you select a motor truck you want to be sure that it is *mechanically right*—one which has demonstrated in actual use that it is adapted to *your* requirements. It is not enough *that it looks good*. What it has done out on the road is the information you want.

But do not let your investigations rest there. Find out about the reputation of the manufacturer. Find out about his financial standing. Find out about his manufacturing facilities. Find out his method and manner of SERVICE.

And when you look into KesselKar SERVICE—the *all-important factor to a truck owner*—you find SERVICE *written into the sale*—not vague promises, but a definite and specific contract, with complete facilities to insure its performance—and back of this service is stability and responsibility.

You are entitled to the *uninterrupted* use of your truck, adequate provision to supply you quickly with duplicate parts, the requisite skill to install or replace them and regular inspection—all at the least possible cost.

There is no truck that can show a cleaner duty record than the KesselKar Truck. There is no other maker that offers you equal service.

Illustrated portfolio just issued--Send for your copy

KesselKar Trucks are built in Six Sizes
1500 lbs. 1, 1½, 2½, 3½ and 6 ton capacity

Kessel Motor Car Co.
546 Kessel Avenue, HARTFORD, WIS.

Boston, New York, Chicago, Kansas City, Milwaukee, Minneapolis, St. Paul, San Francisco, Oakland, Los Angeles, Dallas and 300 other American and Canadian points

KESSELKAR TRUCKS

The Ebel Hoisting Machine

The accompanying illustration shows the Ebel hoisting engine for contractors' use. This is a direct-connected machine. It is furnished in five sizes, ranging from 3 to 12 horsepower.

Contractors find the Ebel a very satisfactory hoist. It

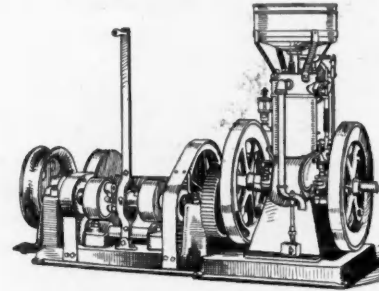

Ebel Hoist and Engine

is strongly built, and is very simple in its design. There is not much chance of its getting out of order.

These hoists are manufactured by the Lansing Motor and Pump Company, Lansing, Mich., who will send further information to any of our readers who are interested.



Klauer Metal Ceilings

The Klauer Mfg. Co., Dubuque, Iowa, are making a strong bid for business with their line of very attractive stamped metal ceilings. A special feature with these people is that with every ceiling they furnish a blue-print or working drawings showing the exact size and arrangement of each member of the combination ceiling design. They also send a packing slip giving an itemized list of the material shipped. This prevents chance of lost goods or overcharge.

The design illustrated is one of their popular numbers; a

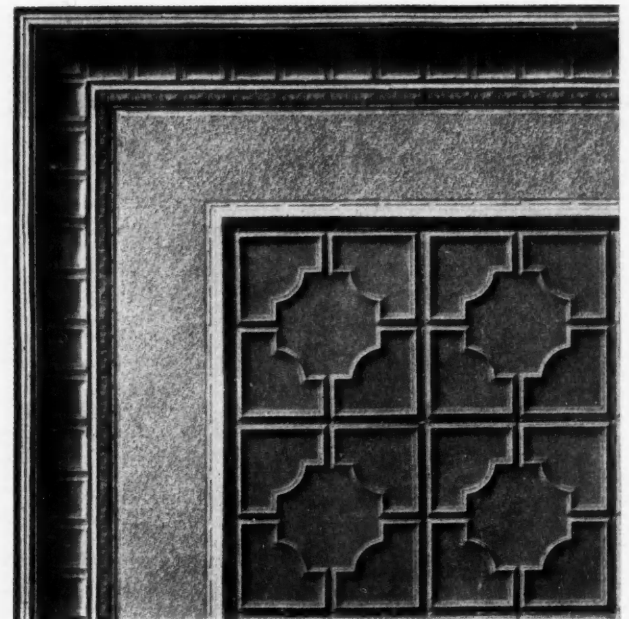

Klauer Mfg. Co. Metal Ceiling

Colonial wood panel design. The illustration shows how their designs mitre together at the room corners.

A large illustrated catalog showing the Klauer line of stamped metal will be sent AMERICAN CARPENTER AND BUILDER readers who are interested and will write for it. This catalog is very much worth while, both for the new designs it contains and for reference.

You will get SPECIAL ATTENTION if you tell Advertisers you read American Carpenter and Builder.

SEND FOR OUR CATALOG. "HOME HEATING"

HOT-WATER HEATED \$198

by **ANDREWS SYSTEM** EACH



14 ANDREWS HEATERS IN ONE BLOCK AVERAGE PRICE \$198⁰⁰

IT IS WELL WORTH READING

The Andrews Method Especially Adapted to Builders' and Contractors' Work

For 13 years Andrews has sold hot water heating plants by the original Andrews Method—complete plants made to fit each job's individual requirements, cut to fit and shipped ready to screw together by the purchaser or any man handy with tools. Now, in 2,274 towns and cities of this country these plants are in operation and giving fine satisfaction. Most of the new business received each year is ordered at the recommendation of previous purchasers. This idea is particularly adapted to use of builders and contractors. We take the risk, do all the work of estimating, planning and building the plant, ready to screw together—leaving nothing but the installation to the builder. This work can be done mostly by a helper, following the simple yet complete instructions given with each job, enabling the contractor to make a profit on the installation as well as on the heating plant itself.

We Take All the Risk and Make Complete Erection Plans

Taking the risk as an item very important to contractors, we know by years of experience that Andrews Systems will "stick" satisfactorily, so we can afford to assume the responsibility. And the estimating, planning, etc., our engineers do for builders, saves them a great amount of work and provides against their loss through errors.

360 Days Free Trial Guaranteed by Bond

This free trial is no "joker." We stand ready at the end of the trial period to buy plant back at its full price if it is not satisfactory in every claim we make.

All Material the Very Best

The Andrews material is famous for its high quality. Our reputation is made on square dealing and genuine merit in our plants.

72 Page Heating Book Free

Write for It Today

This big portfolio book of 72 pages contains information every builder and contractor should have. It gives new angles to the heating problem and by description, photographs and diagrams it makes clear the real merits of the Andrews Systems of Heating, as well as telling about the several other Andrews features for modernizing the home—such as Steel Septic Tanks for Sanitary Sewage Disposal, Thermostats, Plumbing System, Air Pressure Water Supply Systems, etc. These are all sold by the Andrews Method—cut-to-fit, ready to screw together. Write for the book and you will then realize the worth of the information it contains.

Special 30 Day Offer

To inquiries from American Carpenter and Builder readers received during the next 30 days we make a special offer well worth taking advantage of. Get your inquiry for catalog or estimate in early and be in line to take advantage of the extra offer we make for the 30 days.

Andrews Heating Company
1406 Heating Building Minneapolis, Minn.

Andrews Steel Boilers

Andrews Boilers are made of steel plate, same as large power boilers. They afford nearly double the fire travel of cast-iron boilers of equal capacity, which enables them to heat the system perfectly with less fuel. They are durable, can be cleaned in a few moments, and are extremely simple to operate. The grate, the combustion chamber, the deep ash pit, are all designed to give the most perfect service and greatest economy.

Andrews Regurgitating Safety Valve and Group System of Piping

The Andrews Regurgitating Safety Valve, an exclusive feature of these systems, provides safety and permits use of smaller radiators to obtain the desired temperature. The group system of piping enables each radiator to heat up evenly, so that the entire house is comfortable.

Write for Free Estimate

It will cost you nothing to learn the cost of a complete plant for your next job, and learn all its advantages as well. Just send us architect's plans or rough diagrams of the basement and floor plans showing sizes—windows, doors, height of ceilings, construction, etc., and our engineers will give you a complete estimate on the job covering boiler, piping all cut, reamed and threaded, fittings, radiators, floor plates, operating tools, bronze brushes, etc.—everything all ready to screw together and shipped, freight prepaid, to your nearest freight station. Nothing is lacking and everything is the very best.

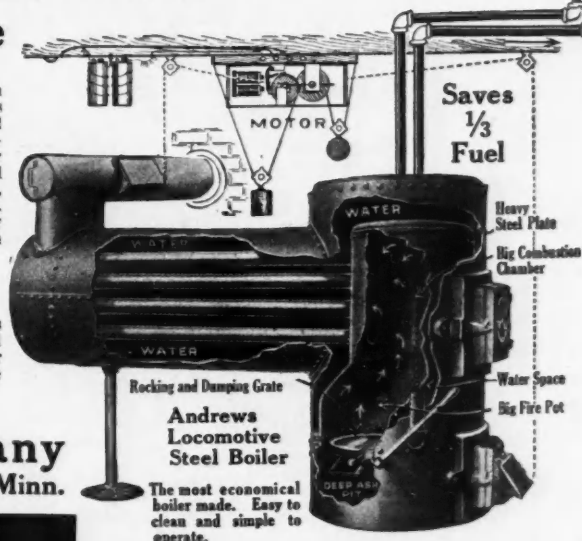

Andrews Locomotive Steel Boiler
The most economical boiler made. Easy to clean and simple to operate.

You will get **SPECIAL ATTENTION** if you tell Advertisers you read American Carpenter and Builder.

"Veribest" Asphalt Shingles

There are so many good reasons for using asphalt shingles that it seems queer builders didn't begin using them sooner. Of course, though, it's more the fault of the shingle makers; for, come to think of it, it hasn't been so very long that first-class modern asphalt shingles have been on the market.

Whoever thought of them first, it didn't take the building public long to catch onto them once they were introduced.

The Veribest asphalt shingles, manufactured by the McHenry-Millhouse Mfg. Co., South Bend, Ind., have been called the twentieth century shingle. They give a building an attractive appearance, require no paint, and will last an indefinite number of years. Fire-resisting, low in first cost, stylish in appearance, requiring no expense for up-keep, these shingles appeal to a builder's judgment.

Veribest asphalt shingles are cut 8 inches wide and 12¾ inches long. In laying, 4 inches of the length is exposed to the weather, consequently when the shingles are laid, they form three thicknesses of absolutely waterproof material. These shingles are used on all classes of residences and public buildings. They are just the thing for porch roofs, bay windows or dormers, etc., as on account of their pliability they can be made to fit any corner or angle.

These shingles come in four colors; namely, dark red, gray, green, and brown. The color is obtained by the use of crushed slate for the weathering surface coat. The colors are accordingly fadeless.

Another valuable product of the McHenry-Millhouse Mfg. Co. is their "Wodwalboard," a high-grade wall board for the finishing of any room. The claim is made that

one-half the lathing and plastering expense is saved by using "Wodwalboard" for offices, restaurants, store rooms, garages, etc. Also for the principal rooms of residences, as well as attics and dens, this wall board is being freely used.

The McHenry-Millhouse Mfg. Co., South Bend, Ind., have a good supply of illustrated circulars and catalogs which they will gladly send to carpenters and builders who are interested.



Bolte Concrete Mixer

The development of the Bolte concrete mixer was accomplished by four years of constant experimenting. The inventor, who was a contractor of considerable knowledge and experience and realized what is required in such a machine, turned his knowledge to practical account, and produced a continuous concrete mixer. The manufacturers advise that since placing the Bolte mixer on the market they have enjoyed a very large sale among contractors and engineers.

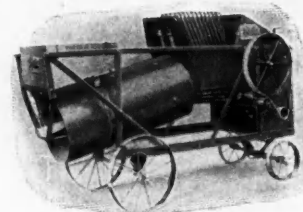

Bolte Mixer

Two styles are offered. Their Model B hand power machine, and their Model C, which is equipped with gaso-

line engine, 1½ hp. The hand power machine weighs 600 pounds and its capacity is 6 cubic yards per hour. The Model C weighs 1,000 pounds, equipped with gas engine, which has a capacity of 10 cubic yards per hour.

These machines are well made; reasonable in cost. For full particulars address the Bolte Mfg. Co., Kearney, Neb.

YOU WANT THE BEST GET THE SAND'S ALUMINUM LEVEL

This level will please you. You'll not be satisfied to use a heavy, clumsy, level any more. The old wooden level splits, cracks and warps. The iron rusts, expands and contracts. These things throw the level out of adjustment.

The SAND'S LEVEL is made in two sizes—24-in. and 30-in., for Carpenters and Builders, and in Mason's sizes. Made of high-grade aluminum. Never loses its fine finish. All vials have heavy plate glass covering on both sides. No dirt or dampness can get in. The plumbs at each end and the double center level vials make it readable in any position or at arm's length. Sand's Aluminum Level is superior to all others.

There
Is Only One
Aluminum
Level

and we make it. You couldn't buy a finer level if you searched the world over. Take it with our guarantee that it is absolutely true and reliable. It will last longer than a life time.

See It Before You Buy

You'll be anxious to see this fine tool. Ask your hardware man to show you a Sand's Aluminum Level. If he hasn't got one, write us. Tell us you'd like to see this level without feeling obliged to buy. We'll send you a level by express. Examine it. If you don't want to buy it, hand it back to the express agent. That's all.

J. Sand
&
Sons

1023-25 Rivard St., DETROIT, MICH.

You will get SPECIAL ATTENTION if you tell Advertisers you read American Carpenter and Builder.

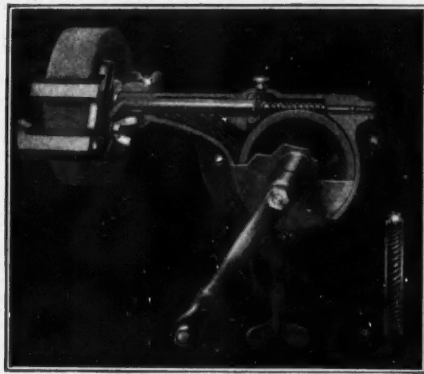

You can sharpen any tool easily with this ball-bearing "running-in-oil" grinder

Dimo-Grit "The wheel for steel"

Luther Grinders are the only tool sharpeners equipped with wheels of DIMO-GRIT, the marvelous, new, artificial diamond sharpening substance. DIMO-GRIT cuts the hardest steel as easily as emery does copper. *No water needed. No danger of drawing temper.* Lasts longer and sharpens tools many times faster than emery. Increases your own efficiency as well as that of your tools. All DIMO-GRIT wheels are guaranteed for five years.

Double Faced Sharpening Wheel—In "Best Maide" Grinders the grinding and finishing are both done on one wheel. The tool is quickly brought to an edge on the medium grit body and is then smoothed off and finished on the fine grit side-face. No other grinder performs both these operations on a single wheel.

Sharpening Attachment for Twist Drill—This special attachment enables you to sharpen twist drills perfectly on the "Best Maide" Grinder. By its use, you can easily keep your drill-sets in perfect working order.



Hand Power Breast Drill—By means of a special drill attachment the Luther "Best Maide" Grinder can be used for free hand drilling, as illustrated.

This will often prove a big convenience.

Hand Power Bench Drill
The attachment shown above converts the "Best Maide" into a very practical shop drill.



Upright

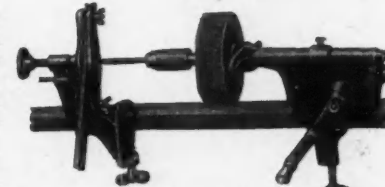

The attachment shown above converts the "Best Maide" into a very practical shop drill.

The attachment shown above converts the "Best Maide" into a very practical shop drill.

LUTHER "Best Maide" TOOL GRINDERS

In addition to being highly efficient general purpose tool grinders, these machines can, by the use of special attachments, be employed for many other shop operations, which adds greatly to their value.

Perfect Worm Gear

The worm gear and shafts of these "Best Maide" Grinders are accurately cut from solid steel by special machines of our own designing. They are of sufficient diameter to provide great wearing

surface and make the grinding wheel run true without vibration. Ball bearings take up all end thrust and assure wonderful ease, speed and quickness in operation. The driving gear is concave, making it impossible for the gears to become off-centered, burred or to creep.

Improved Swiveling Device

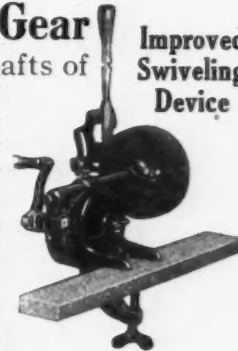

If your hardware dealer cannot supply you with a Luther Grinder, mail back the coupon, properly filled out, for free pocket hone.

Luther "Best Maide" Grinders are sold by nearly all leading hardware dealers. If, on inquiry, you find that your dealer does not handle Luther Grinders, do us the favor of sending in his name and the name of the tool grinders he does handle, and we will mail you a handy little DIMO-GRIT Pocket Hone FREE for your trouble. Use the attached coupon and get our descriptive folder telling about "Best Maide" Grinders.

LUTHER GRINDER MFG. CO.

812 Point Street

MILWAUKEE, WIS.

FREE HONE COUPON

Luther Grinder Mfg. Co.
812 Point Street, Milwaukee, Wis.

In compliance with your condition for Free Hone

I make the following report:

Dealer's Name

Grinder Handled

Please send me Free your Special Folder illustrating and describing Luther "BEST MAIDE" Tool Grinders.

Name

Address

You will get SPECIAL ATTENTION if you tell Advertisers you read American Carpenter and Builder.

UNDERFEED

FURNACE OR BOILER
CUTS YOUR
COAL BILL $\frac{1}{2}$ to $\frac{2}{3}$

Mr. Builder:

BE sure that the atmosphere within your building is *right*. When you specify the UNDERFEED you are absolutely *insuring* clean, even, *adequate* heat at the *least* possible cost. The Underfeed—either Furnace or Boiler—*emphatically* ADDS to the RENTING or SELLING value of *any* building. The reasons therefor are easily understood by anyone who has ever paid a coal bill. Underfeed is the greatest word in the *economy* of heating. Over 25,000 satisfied American and Canadian users KNOW that the Underfeed has actually *cut* their coal bills in two and in some cases even in three.

We want you to know all about this modern, money-saving system. Write TODAY for FREE Booklet which fully describes

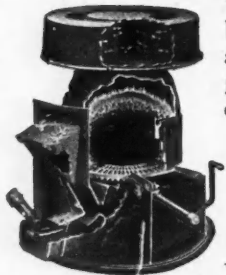

Furnace

THE PECK Williamson Underfeed FURNACES BOILERS

The Underfeed saves \$2 to \$3 a ton on coal, burning *cheaper* grades of hard or soft coal—slack, pea or buckwheat sizes. All *fire is on top*—close to heating surfaces, which are thus kept free from heat-retarding soot.

Thousands have given cheerful testimony of Underfeed appreciation. Here are samples read by millions of magazine readers in February:

Fuel Saving Mr. John P. O'Neil, Logan Square Station, Chicago Post-office: "No more topfeeds for me. Saved about \$30 last year."

Consumes Gases Mr. J. A. Staples-Topeka, Kansas: Underfeed Boiler makes good. Consumes smoke and gases as they pass through live coals."

Prevents Waste Mr. C. C. White, Garret, Ind.: "Have only emptied ashes twice in a year. I burn them up."

Ease of Operation Mr. Walter N. Post, Commerce, Mo.: "The easiest furnace to operate I ever saw. Wife has no trouble when I'm away."

Lasting Worth Mr. J. T. Johnston, Freeport, Ill. (rural route No. 6): "This is our seventh winter. Underfeed does as well now as when first put in. My mother, mother-in-law, brother and sister all did away with top feeds and now have Underfeeds."

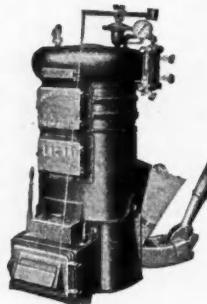

Boiler

Send rough sketch or blue print of your floors and basement and we will forward FREE heating plans and estimate of cost.

Underfeed heaters are adapted for both large and small buildings. Installed in unit or battery form in residences, apartment houses, halls, churches, theaters, schools, etc.

Write TODAY for FREE Furnace or Boiler Book and fac-simile testimonials.

THE PECK WILLIAMSON CO.

436 West Fifth Street

CINCINNATI, OHIO

Clover Leaf Equipment for Builders

The Clover Leaf mortar and concrete mixer has become famous as the mixer that is easily kept clean. The shape of the mixing drum is responsible for this. The "involute curve" does the mixing; no wings or deflectors are required.

The Clover Leaf Machine Company, South Bend, Ind., have for years been manufacturing thoroughly well designed machinery. This experience, together with their fine manufacturing equipment, with the latest improved machinery, and a force of skilled mechanics, enables them to offer their present line—right in quality and right in price.



Clover Leaf with Folding Loading Platform

The Clover Leaf mixer mixes mortar or Portland cement concrete equally well. It comes in four sizes, of capacities rated, respectively, 35 to 50, 60 to 70, 80 to 100, and 100 to 140 cubic yards per day of 10 hours. All the standard models are offered on skids, and on trucks, and with either gas or steam engine power. Numerous special improvements are offered in the 1914 models. The illustration shows the folding loading platforms which are valuable time-savers for sidewalk contractors foundation builders, etc. They go to make up a mixing outfit of extreme portability.

All of these features are well covered in the new catalogs these people are distributing. Builders' hoists are also an important part of the Clover Leaf line, as featured in their catalogs. Write the Clover Leaf Machine Company, South Bend, Ind., for their illustrated booklets.



Larger Space for Vapor Vac. Co.

On or about January 1st, Vapor Vacuum Heating Company moved to their new suite of offices, located on the second and third floors at 1215 Walnut Street, Philadelphia.

This move has been made necessary by their constantly expanding business, which practically doubled itself during the past season, necessitating increased accommodations to permit their engineering staff to keep up with the increasing volume of work that they have to take care of.

Vapor Vacuum (Kriebel System) is making great strides, and is finding its way into many of the leading banks, churches, schools, public buildings and private homes, and in each case the company advises us that they have had no difficulty in fulfilling their guarantee of saving 25 per cent of the fuel necessary to run the older systems of heating, and in many cases the saving has been as high as 30 to 40 per cent.

The Kriebel system can be installed to work in conjunction with any of the types of boilers advertised in our columns. and it will give uniformly satisfactory results when properly installed.

They have just issued a very comprehensive treatise on the Kriebel system, as applied to the modern boiler, which they will be glad to send to anyone interested.

You will get SPECIAL ATTENTION if you tell Advertisers you read American Carpenter and Builder.

Holland Furnaces Make Warm Friends When you Specify a Furnace— Choose "A HOLLAND"

"The Heart of the Home"

Has fewer joints, smaller joints, is simpler and easier to operate than any other make. It will burn any kind and all grades of fuel—hard coal, soft coal, slack or wood — without waste of gases, without internal explosions and without opening of joints.

You can buy no cleaner Heating Plant than a Holland Furnace.



The Holland Furnace, size for size, will give more heat from fuel consumed than any other furnace on the market, because it has the grate surface, the radiation and the most perfect and natural way of burning fuel.

Sold under a Double Guarantee from factory direct to consumer.

HOLLAND SERVICE FOR BUILDERS

Send us your floor plans. Mark the rooms you want heated. Our expert heating engineers will submit to you detailed plans, specifications, prices, etc., covering the entire heating equipment. We furnish this service FREE. It enables you to install **Holland Heating Equipment** as well as an expert can do it.

We Want a Reliable Agent in Each Town to take orders and instal Holland Furnaces. You can qualify. Don't doubt. We give you complete instructions so failure is impossible.

Ask for Catalog and Agency Particulars
Holland Furnace Co.

HOLLAND
MICH.

Largest Direct Installers

of Furnaces in the world.

You will get SPECIAL ATTENTION if you tell Advertisers you read American Carpenter and Builder.

Money in Canvas Gloves

It would be hard to tell just how, when and where, the canvas glove originated, but the fact remains that they have come. Have come to stay.

In the comparatively few years that they have been on the market, since their manufacture has grown into big industries, they have forged to the front in leaps and bounds. They are worn by all classes, from the millionaire who putters around his garden or with his horses or dogs, to the laboring man earning but \$1.50 a day.

They are equally in favor with the busy housewife in her household duties.

They have cut in upon and revolutionized the leather glove industry. Their very cheapness, the excellent service they give, insures for them a permanent continuance of the popularity they have gained with all classes.

Canvas gloves have made themselves almost indispensable to the working man. They have been the means of establishing men and women having but small capital, in a manufacturing business, as but a sewing machine or two, a few yards of cloth and a disposition to work is all that is necessary to start the business.

The McCreery Mfg. Co., of Toledo, O., is a bright example of what wonderful possibilities canvas gloves really hold for ambitious men and women. They started a few years ago with two second-hand sewing machines, plenty of ambition, far-seeing eyes into the future of the business, and in three years' time built and paid for a large factory and are now doing a big business in this field.

They have realized the impossibility of supplying the demand for this article through their own factory and are starting energetic, ambitious men and women in the business in their own localities where they can make and sell these gloves locally to merchants and jobbers in their territory as cheaply

as those concerns could buy them from bigger manufacturers farther away.

It might seem strange at first thought that they would start these factories in competition with themselves, but when their plan is explained it is easily understood, and is upon a business basis in that they establish a man in the business, then sell him the goods from which the gloves are made. In fact, as they state it, these factories started, become in reality independent branches of their large Toledo factory, all working together for the good of all. It is a commendable idea, practical, and has proven successful.



"Stone Making by the Pettyjohn System"

The cement block industry has gone through several changes in the last half dozen years. Probably it was over-boomed in some sections. Even a good thing can be, and often is, overdone. But now it seems that cement block making has reached a place of permanency. For certain structures cement blocks are cheapest and best. They will always be used.

The Pettyjohn Company, 534 North 6th Street, Terre Haute, Ind., have a very instructive booklet or catalog which bears the above title. In a few words it tells what every contractor and prospective block maker wishes to know about the block business. The booklet is well written and well illustrated. This has recently come to hand along with two other very worth-while booklets from the same company. One is "Ornamental Illumination," which illustrates and describes their granite concrete lighting columns. The other is entitled "Enduring Concrete." This presents some very striking illustrations of ornamental concrete pillars and columns, especially for porches and pergolas.

Any one or all of these booklets will be sent our readers on request.



Concrete and Lumber Go Hand in Hand

Builders, Carpenters, Contractors, have discovered the great money making possibilities of making Ideal Concrete Blocks and Concrete Stone in general.

It is the Legitimate Side Line

That is the reason Ideal Machines are busy in hundreds of Lumber Yards.

We build and install Hand Power or Machine Power Equipment.

We build Mixers for any kind of service.

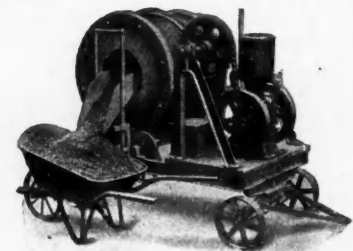

Makers of High Grade Concrete Machinery

Block Machines

Brick Machines

Dimension Stone and

Curb Stone Machines

Automatic Power Tampers

Conveyors and Feeders

Batch and Continuous

Mixers

Ornamental Molds, Sill and

Cap, Fence Post, Drain and

Sewer Pipe Molds, Tycrete

Waterproofing and Colors

Ideal Concrete Machinery Co.

London, Ont. Canada

1308 Monmouth Avenue, CINCINNATI, OHIO

You will get SPECIAL ATTENTION if you tell Advertisers you read American Carpenter and Builder.

—“the heart of all equipment is it's power”

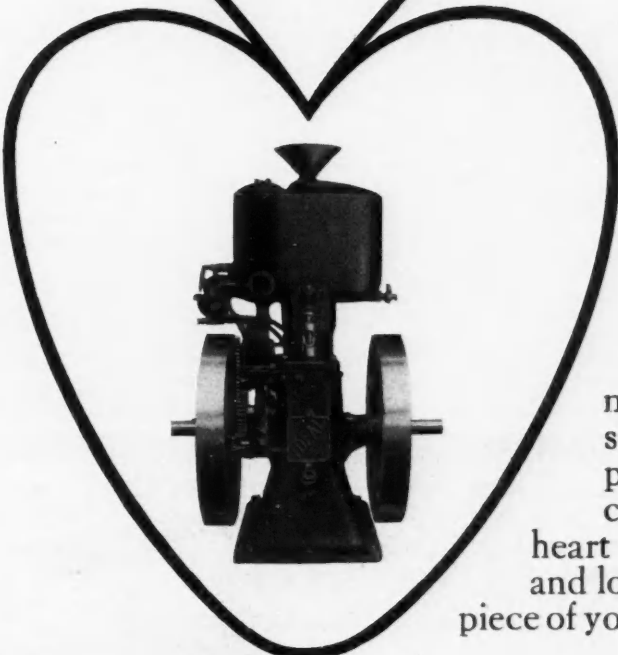

Don't give your equipment heart failure!

Many a good piece of machinery has gone the junk route because of poor engine. Many a contractor has lost thousands of dollars because of engine trouble—why should this be? The engine—the heart of every piece of equipment. The one factor that means the most on the cost side of every profit sheet. “Ideal” power, the cure for all equipment that has heart trouble. It boosts your profits and lowers your operating cost. Every piece of your equipment should be driven by

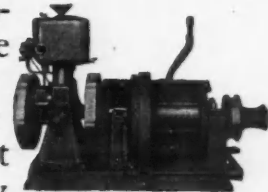

“Ideal” Type M Engines

Did it ever occur to you to fully investigate your power before buying? Seventy-five per cent of the contractors buy engines that they know nothing about—then when the outfit goes wrong they swear that they have been “bunkoed”—it's not so. If they had looked into the power problem as carefully as they did the rest of the outfit they would have been on the safe side. It's never too late—remember next time when you buy equipment—buy “Ideal” power.

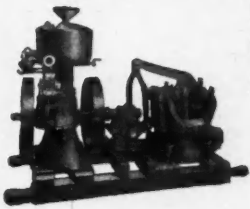

Original Gas Engine Co.

R. E. OLDS, Chairman

630 Kalamazoo St., E. LANSING, MICH.

“Get next to ‘Ideal’ Power”

“We have heart trouble, send us a cure”
Name.....
Post Office.....
Town.....
State.....

You will get SPECIAL ATTENTION if you tell Advertisers you read American Carpenter and Builder.

Why Buy an Elephant to Do the Work of a Horse?

**Save \$10 to \$20
a Day**

*By Using the Portable, Light-weight, Rapid,
Smooth-running*

EUREKA SELF MEASURING MIXER
"WHERE GUESS WORK ENDS"

Engineers, Contractors, Builders: If you haven't awakened to the remarkable possibilities of this self-measuring mixer and its astonishing advantage over any batch mixer you ever saw, you are overlooking the biggest money-saving opportunity that anybody could possibly offer you in connection with concrete production.

Before you buy another Mixer, read our Catalog No. 36.

It describes the advantages of the EUREKA Self-Measuring Mixer of half the weight, half the first cost, one-third the operating cost and EQUAL CAPACITY.

Ask about the EUREKA FIFTY—the special outfit for building contractors. **Fifty yards a day.** Low price, strong, serviceable, just the mixer for small jobs.

**Over 300
Eurekas
Used in
New York
City**

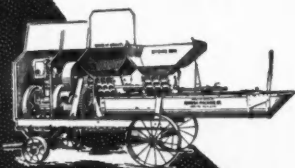

*NO WHEELING
NO WAITING
NO GUESSING*

Positively guaranteed to be superior to the ordinary mixer in advantages, quality and performance.

Ask for Catalog No. 36, and Names of Eureka Users in Your Territory.

**EUREKA MACHINE
CO.**

12 Case Street
LANSING, MICHIGAN

W. V. JOHNSON & CO.
General Eastern Agents,
1 Madison Avenue,
New York
City

*Stocks in
Principal
Cities*

Are You Hand-Sawing Form Lumber?

This is the question the C. H. & E. Mfg. Co. are putting to contractors. They go on to say that if you are sawing by hand all your false form lumber in heavy concrete and bridge work, their No. 4 All Iron Portable Saw Rig is the equipment you want on the job. This outfit is the latest in a combination portable wood-worker having a capacity of 6-inch lumber on the rip and 8-inch lumber on the cross cut.

The engine and saw table are mounted on 4-inch channel iron skids, reinforced with 4-inch by 4-inch yellow pine. The end frames of the saw table are cast iron. On these is mounted and hinged an accurately planed 42-inch by 66-inch iron table, with screw adjustment for raising and lowering.

The 6 H. P. Water Hopper Cooled Gasoline Engine is their very latest design and under break test has been made to pull 7¾ H. P., giving ample power.

The engine drives to tight and loose pulleys on a countershaft, so that the belt can be shifted, driving the saw arbor pulley from a large pulley mounted on the countershaft.

This is an exclusive C. H. & E. feature and gives this No. 4 All Iron Saw Rig a large belt surface, larger than in their other design of Portable Saw Tables, where the saw arbor pulley is driven direct from the engine fly wheel with one belt. With the double belt arrangement the saw and boring outfit, as well as the jointer, can be brought to a stand-still without stopping the engine.

The boring attachment is of the vertical type, being operated from a pulley mounted on the end of the countershaft.

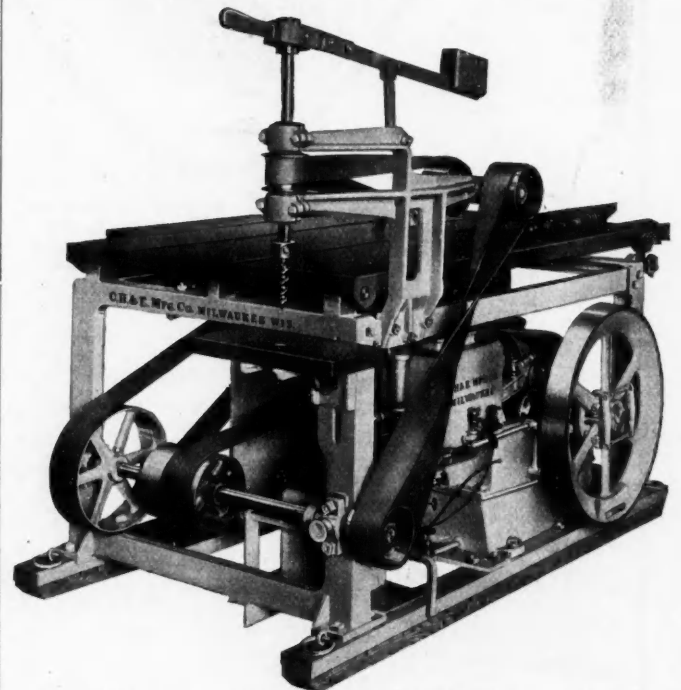

No. 4 C. H. & E. All Iron Saw Rig With Boring Attachment

This boring attachment is fastened to the main saw table with three bolts, and is easily mounted and dismantled.

The jointer has a 6-inch cylindrical head with four knives installed and operates on the opposite side of the table to which the boring attachment is fastened.

An iron adjustable jointer gauge is supplied with this jointer attachment and its operation is very satisfactory.

This is an outfit complete in every detail and the results of years of study, of actual test and engineering skill. Address the C. H. & E. Mfg. Co., 322 Mineral St., Milwaukee, Wis., for further particulars.

You will get SPECIAL ATTENTION if you tell Advertisers you read American Carpenter and Builder.



ON THE CONCRETE JOB WITH THE SMITH HAND MIXER

CONCRETE
SIDEWALKS

BRIDGE
ABUTMENTS

FOUNDATIONS
CURB and
GUTTER WORK

BARN
APPROACHES

WELL CURBS
ETC.

ANY small concrete job can be handled to advantage with a Smith Hand Mixer. Four men with one of these machines can mix twice as much concrete as by hand. With the machine they secure a uniform mix easily and without undergoing the back-breaking strains of shovel mixing.

Run a Smith Hand Mixer between your sidewalk forms and discharge the concrete directly into place without wheeling.

Tie a Smith behind your wagon and run out along the highways and put in your bridge abutments, culverts, etc. You'll find you can easily cut your cost in half.

Elevate this Hand Mixer over your foundation forms and chute the concrete directly into place. Cut out the extra expense of wheeling the mixed concrete from mixer to forms.

This machine is well adapted to curb and gutter work as it is light and very portable. Run it along as the work progresses and save the bother of moving a heavy mixing platform.

The Smith Hand Mixer might well be called the "Farmer's Friend" for it can be used on the farm in a dozen different ways, all of which will prove to be money savers. Build your barn approaches, floors, etc., pig-pens, hen-houses, wells, curbs, etc., with it. Make them sanitary and everlasting. You'll find it pays and pays well.

Write for our special booklet covering the Smith Hand Mixer and see just what this machine is. Send for it now—Booklet No. 17-W.

The T. L. Smith Co. 1138 32nd Street, MILWAUKEE, WIS.

MAIL THIS
COUPON
NOW



Give "UNCLE SAM" One of Your
SMITH HAND MIXER
FOLDERS No. 17-W

For
City
State

You will get SPECIAL ATTENTION if you tell Advertisers you read American Carpenter and Builder.

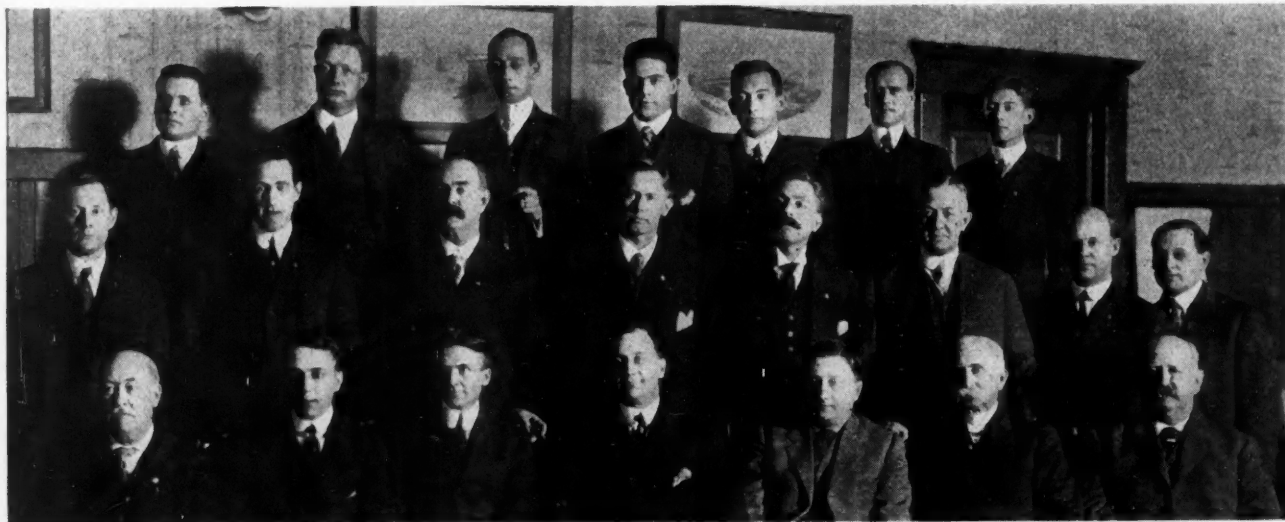

1st Row: Mr. C. D. Gardner Mr. John Yohe, Manager New York Branch Mr. E. R. Eckis, Treasurer Mr. A. B. Clark, President
 Mr. W. W. Clark, Manager Mr. A. P. Phillips Mr. M. Diuguid
 2nd Row: Mr. W. R. Lyman, Sales Manager New York Branch Mr. H. W. Baker Mr. W. A. Ziegler, Manager Minneapolis Branch
 Mr. E. V. Dayhuff Mr. C. S. Watters Mr. L. E. Hively Mr. W. H. Gardner, Sales Manager Ceiling Dept. Mr. C. E. Saint,
 Sales Manager Roofing Dept.
 3rd Row: Mr. Frank Kiley Mr. J. P. Williams, Manager Furniture Dept. Mr. J. E. Prager Mr. G. D. Ketterer Mr. L. R. Kesper
 Mr. H. S. McClelland Mr. Harry Formet

Sales Convention Held

The Canton Art Metal Co., manufacturers of high grade sheet metal products, Canton, O., held their fourth annual sales convention recently. They report a very successful convention; the men all appeared to be optimistic and the reports made by the men were of an optimistic strain.

The first day was given over to discussion of the general line, including roofing, eaves trough, conductor pipe, and

accessories, metal shingles, siding, etc. The morning of the second day was devoted to tin plate, and the afternoon to skylights, cornices and special sheet metal work. All the next day was devoted to metal ceilings, and the next was given over to building reports. The last two days were devoted to general business and discussion of the outlook for 1914.

Many of those in attendance pronounced this one of the best meetings we have ever held.



\$300 MONTHLY for YOU

BE MY GENERAL AGENT IN YOUR COUNTY! GET INTO AN HONEST, DIGNIFIED BUSINESS of your OWN!

The man who makes big money doesn't depend upon his own efforts. He organizes other men and makes a profit from their labor, too. I show you how to do just that. Give you valuable exclusive sales territory absolutely free. Put you in a position to manage a large crew of successful agents and make fat commissions on their work as well as yours. With the fastest selling specialty on earth—with the help I can and will give you, and with money rolling in from your own sales and the sales of from six to ten men working under your direction—YOU SIMPLY CAN'T HELP BUT SUCCEED.

You are an opportunity seeker. All you want is the chance. I know you will do your part. If anyone will convince you that he can establish you in a paying, honest, dignified business where big money is practically sure, you'll take the job, won't you?

All right, I'll take you up on your own proposition. I'll appoint you as my representative on that very basis. I'll convince you that we've got the best selling specialty in existence. I'll prove to you that when you secure the exclusive representation for your county that you're not entering into a dinky, paltry agency proposition. You're putting yourself in line for an amazingly big paying business of your own with profits of from \$30 per week upward.

Over 70% Are Without Bath Rooms

In country and small towns and cities, the percentage is vastly greater than that. These people have gone without the exhilarating, invigorating health-giving bath, simply because until now they could not get it. They have used all sorts of makeshifts, sponge baths, wooden, zinc and metal tubs of various kinds. Heavy, clumsy, unsanitary, in-the-way tubs. Lugging them in and out before and after the bath. Taking up valuable space all the time.

I have invented a practical bath tub that can be used in any room—bedroom—sickroom—kitchen—anywhere—a tub that can be sold at a price within reach of the masses—a tub that is light and yet durable, one that can be folded up and stood up in any corner when you are through with it.—THE ROBINSON STEELINE PORTABLE BATH TUB.

I wish I could show you this wonderful tub. Look at the picture. See how it folds up after the bath. Pick it up with one hand and stand it away in a corner just as you would an umbrella. Isn't that the climax of convenience? In use it's as stable as the stationary tub—as luxuriant a submergent bath as any city bathroom affords—Can't tip or splash, equipped with a handy self-emptying device—plenty of room—just the right shape—simple—perfect, absolutely ideal. We build it of STEELINE, the wonderful new material, and guarantee it for ten years.

YOU MAKE \$5.00 ON EVERY SALE

Think of it. What's the use of wasting your time and effort pushing some specialty that sells for a few cents, when the same time and energy will make you \$5. You get exclusive territory. We protect you. Give you county rights. No cost to you to secure exclusive territory. Then you can appoint sub-agents. If you are a hustler you can make more on this proposition than many a high class salesman makes on a straight salary. In fact there is no limit to what you can earn. Just one sale a day means \$30 a week. Think of that—two a day means \$60 a week.

NO EXPERIENCE NECESSARY I don't care if you have never had a day's selling experience in your life. I know that you can sell this tub and sell it fast enough and often enough to make big money. I know it because fifty per cent of my best representatives are men and women and even boys and girls who never sold a dollar's worth of any kind of goods in their life before they started to work for us.

This is no fairy-tale. No dream of mine. Every word I write is founded on what has been done by the representatives who are now working for me. I know that they are just ordinary men and women. I know that if they can sell these tubs as they are selling them that YOU can do the same thing—that YOU can make the big money just as they do. I want to tell you all about it—what my men have done and what you can do. Let me send you full descriptive matter about my goods and convincing testimonials from others I have helped to succeed.

Write to-day—NOW this very minute—either a postal or letter. These exclusive county agencies won't last long. Pick one of these plums while you can—NOW!

H. S. Robinson, Pres., THE ROBINSON CABINET MFG. COMPANY
 255 VANCE ST., TOLEDO, OHIO For Canadian Territory Write Our Canadian Branch at Walkerville, Ontario, Canada.

I tell you people are simply falling over each other to buy these tubs. All you have to do is to show them and write out the order. In the country and smaller towns practically every home is a prospect. Even in the city it is surprising how they sell. Right here in Toledo, Mr. N. J. Smith is averaging two sales a day. Used to work in a hardware store at \$65 a month; now he makes that much every week. You can, too. I will send you the records of lots of men who are making big money—just ordinary men and ordinary towns.



DEMONSTRATING TUB FREE

I grant credit—Furnish sample. Help you out—Back you up—Don't doubt—Don't hesitate—Don't hold back—You cannot lose. My other men are building homes, bank accounts, so can you. Act then, quickly. Send no money. Just name on penny post card for free tub offer. Hustle!

You will get **SPECIAL ATTENTION** if you tell Advertisers you read **American Carpenter and Builder**.

It is Plain Now What the Contractor Wanted The "Big-an-Little" Has Satisfied Him

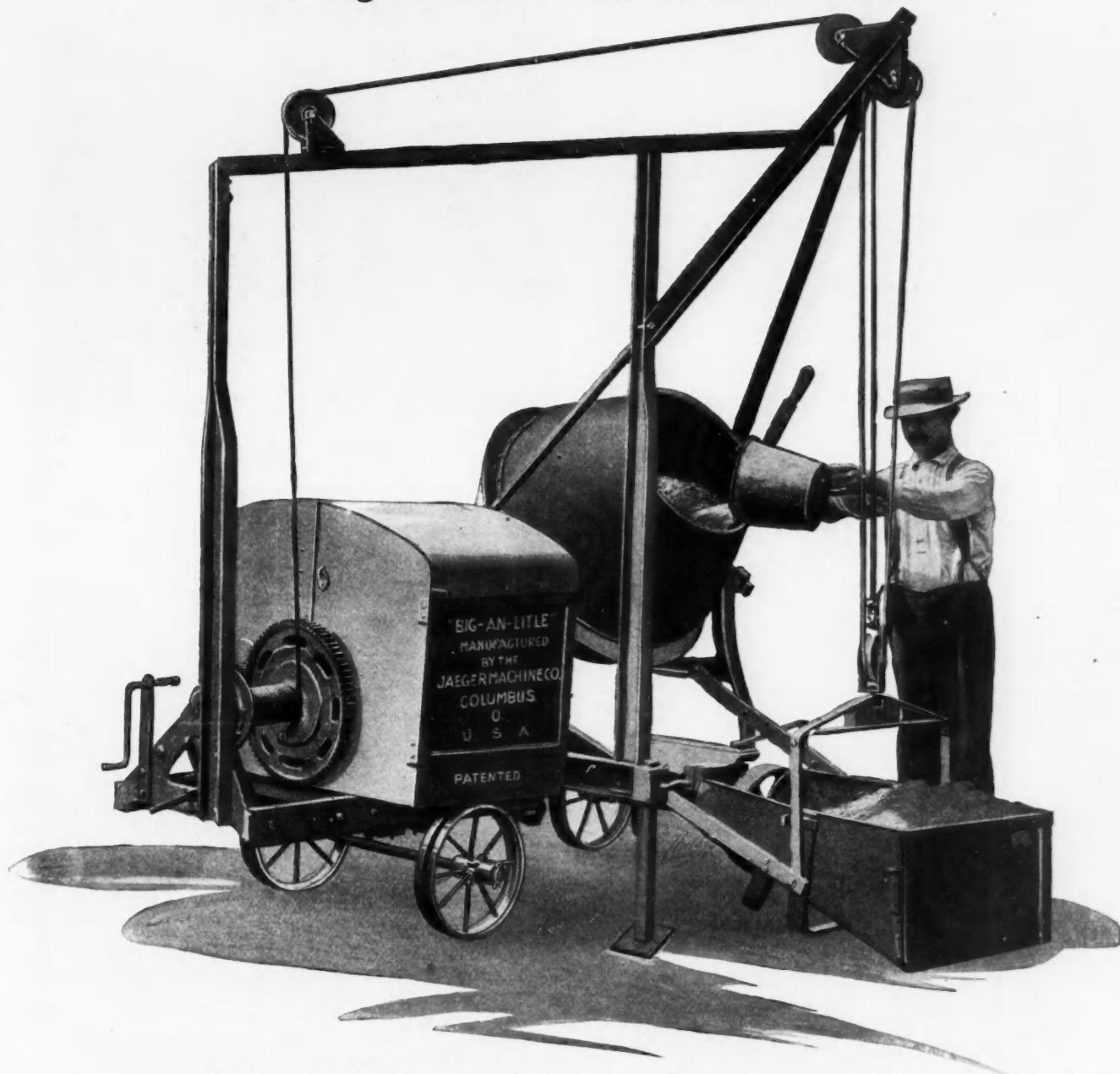

The tremendous enthusiasm shown in the "Big-an-Little" mixers at the Cement Shows, by users, dealers and buyers, is indicative of the exceptional advantages which the "Big-an-Little" line offers.

A mixer of Quality—Powerful—strong—fast—yet economical. We have accomplished in the "Big-an-Little" what other Mixer Manufacturers have overlooked—Jaeger built it. Contractors know the day of the mixing board is gone—as well as the day of the great big mixer for ordinary sized jobs.

True—Mixing boards have been used as well as big lumbering mixers, but the "Big-an-Little" is here and offered you at a low price.

Mixes Mortar as Well as Concrete

Last year the contractors swamped us with orders—Our capacity has been four times increased—We can and will ship your "Big-an-Little" mixer the same day order is received.

You can have the "Big-an-Little" with Hoist and Side Loader, as illustrated. The Loader reduces the time of loading and the Hoist can be used for hoisting all kinds of material. Or you can have the "Big-an-Little" without the Loader, but with the Contractor's Hoist—or you can have it without the Hoist, or even you can get it on skids, if you have your own engine.

They are built for you—guaranteed—sold to you at a price that will surprise and please you.

Get in touch with us at once and receive our 1914 catalog of the 1914 Model "Big-an-Little" mixer, "that is Just a Little Better than the one you thought was best."

JAEGER MACHINE CO.

318 W. RICH ST., COLUMBUS, OHIO

You will get SPECIAL ATTENTION if you tell Advertisers you read American Carpenter and Builder.

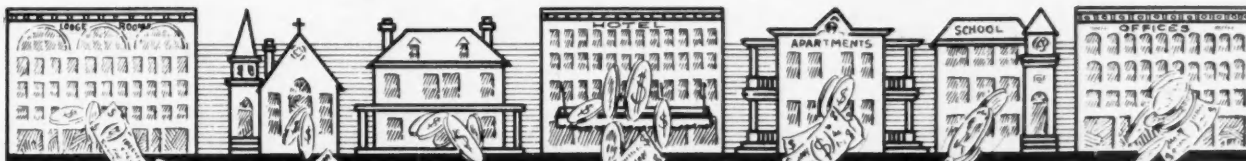

MONEY FOR YOU!

**IN EVERY HOME, OFFICE,
HOTEL, CHURCH OR PUBLIC BUILDING**

**GO INTO THE VACUUM CLEANING
BUSINESS. NAME YOUR OWN INCOME**

Join enterprising men who are earning \$2,500.00 to \$3,000.00 yearly. Better your condition! Become master of your own time—your own income! Write now, for complete information regarding the little giant "B. B." POWER VACUUM MACHINE. Your profits quickly pay for your investments.

Take it on 30 days' trial offer—pay for it on easy terms. Go into the Vacuum Cleaning Business.

Your Neighbors Become Regular and Profitable Customers

Each year the hard work, worry, and health destroying labors of housecleaning time is dreaded more and more by every housewife. All is in your favor! ANY ONE WILL GLADLY PAY YOU HANDSOMELY TO HAVE THIS WORK DONE—you can easily earn

"The B. B. will do all that you claim for it—and more. Make from \$20 to \$25 in six hours easy. It is all to the good. Have even cleaned horses and dogs. It soon gets the dirt and loose hair off horses and even the fleas off of dogs." A. O. Rainbow, N. Mexico.
Your business grows by leaps and bounds of its own accord: We will assist you—launch you properly—furnish you cards—and working plan—supply you with a price list that will net you a good profit—and at the same time WHOLLY SATISFY YOUR PATRONS.

You can pay cash—or buy on easy instalments. Your machine can be PAID FOR OUT OF YOUR PROFITS. We will SEND IT TO YOU ON 30 DAYS' TRIAL. WE HAVE CONFIDENCE IN ITS POWER TO FULLY JUSTIFY EVERY CLAIM WE MAKE FOR IT.

Our new "B. B." machine consists of a powerful two cycle, gasoline, valveless engine, perfectly adjusted, inspected—tested. It is conveniently mounted on a strongly constructed four-wheeled wagon—steel or rubber tires—so well balanced that it can be moved from place to place with the smallest effort.

\$15 to \$30 DAY PROFITS

You should make even more than this. Establish your business; employ men to do the work. As your business grows, YOUR INCOME CAN BE DOUBLED—TREBLED—QUADRUPLED! It is a source of countless opportunities—

Magnificent Profits

Cleaning must be done repeatedly! This means steady contracts for you the year around! With the "B. B." Power VACUUM CLEANER you can revolutionize present methods to your own profit! Rugs, carpets, matting, upholstered furniture can be cleaned in a few hours—One woman engages you—then her neighbors WANT YOU! EVERY DAY—EVERY HOUR—YOUR WORK ADVERTISES YOU! BRINGS YOU BIG PROFITS.

CONVINCING PROOFS Pay Own Way Through College

"The B. B. Machine has given perfect satisfaction. Second day we cleared \$220.00. Work comes to us. We have almost paid for the machine this spring and passed in all our studies. We expect to have two machines next spring." Montgomery & Porter, Missouri.

McCREERY MFG. CO.

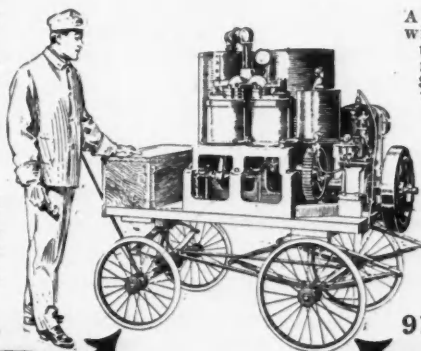

The machine is completely equipped with vacuum condenser water tank, vacuum gauge, high pressure suction hose, observation glass and cleaning tools, all adjusted and ready for immediate use. Simple—easy to operated—small upkeep expense.

Send Now—Today—for Interesting Booklet

A two-cent stamp will bring it to you. It will tell you much. How to get on the path that leads to a big and profitable business—to bring you success. How to earn \$2,500.00 to \$3,000.00 a year—AND ONLY WORK PART OF THE TIME.

\$20 a Day is Good Enough

For Me. I can make \$20 a day, which I think is good for the investment. It is good enough for me. I would not sell it for twice the price. Customers are well pleased with my work. Have three or four regular customers by the month." A. W. Staley, Illinois.

911 Dorr St., TOLEDO, OHIO

The Brick of Quality Hy-tex Brick

Made in every color and every texture known to brick-burning.

Hydraulic-Press Brick Company
St. Louis, Missouri

GET ORDERS

for the UNIVERSAL RAT CATCHER



EVERY farmer, merchant and lumber dealer in your locality will buy one of these Rat Traps. It's a sure and quick way to rid all buildings of the pests. One of these Catchers placed in a livery stable in Scranton, Pa. caught over 100 rats in ONE MONTH. Trap made of galvanized iron; can't get out of order; lasts for years; always clean. 18 inches high, 10 inches diameter. One delivered prepaid upon receipt of \$3. Rats and mice die; no marks left on them.

My proposition requires no time from your work. I can show you how to make money easily. Don't be afraid to ask how. Cost you nothing to find out. I'll guarantee you can sell these Universal Rat Catchers easily.

WRITE TO ME AT ONCE.

H. D. Swarts, Inventor and Manufacturer, Scranton, Pa.

You will get SPECIAL ATTENTION if you tell Advertisers you read American Carpenter and Builder.

"Bull-Dog" Mixers

The term "Bull-Dog" at once suggests the qualities of tenacity, strength, and endurance, and these are characteristic of the "Bull-Dog" Batch Mixers recently added to the well-known concrete machinery line of the Raber & Lang Mfg. Co., 810 Mill St., Kendallville, Ind.

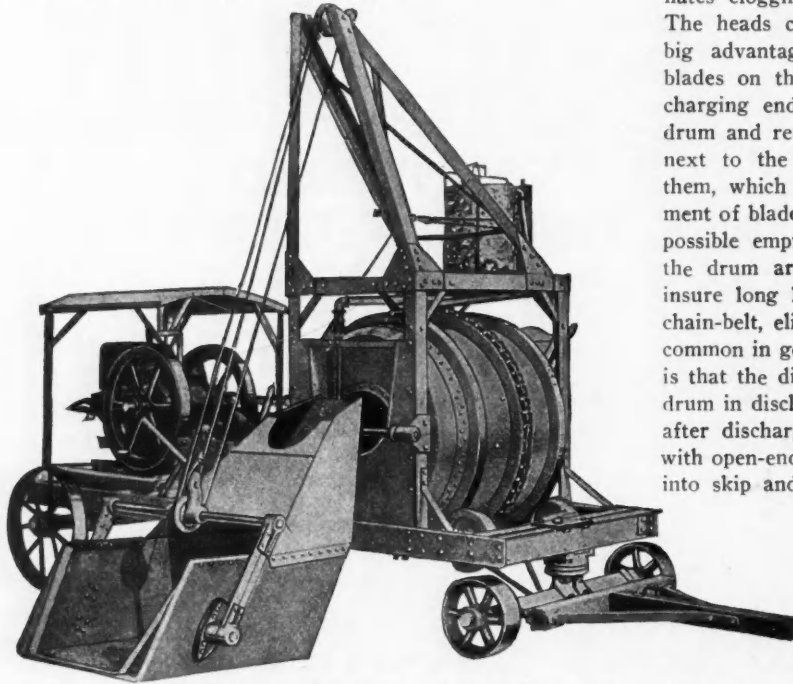

"Bull-Dog" Batch Mixer. Self-Contained Unit With Gasoline Engine and Power Side Loader

These mixers are furnished in any way to suit the needs of the purchaser—with or without power, steam, gasoline, or electric.

The drums are of heavy boiler-plate steel, double-riveted to heavy cast-iron head rings. The ends or heads are also of steel, riveted to the head rings. This arrangement eliminates clogging of material and greatly facilitates cleaning. The heads can be removed and replaced, if necessary—a big advantage. The drum is provided with heavy steel blades on the charging side, and steel buckets on the discharging end, both blades and buckets being bolted to the drum and removable. The blades have a sufficient clearance next to the drum surface to allow water to pass under them, which greatly facilitates cleaning; while the arrangement of blades and cups insures thorough mixing and quickest possible emptying. The roller track and sprocket rings on the drum are made in one piece, with surfaces chilled to insure long life, and are also removable. The drive is by chain-belt, eliminating the trouble from broken gear teeth so common in gear-driving. Another point of special importance is that the discharge chute reaches to the very center of the drum in discharging, and is wholly withdrawn from the drum after discharge. The power loader has a side-loading skip with open-end feature, enabling barrow to be wheeled directly into skip and instantly dumped. If desired, the side-loader can be removed, and a regular or batch hopper substituted. An automatically measuring water tank is provided, which can be connected to any pressure source of supply; a float and inlet valve shut off the supply when tank is full; and a lever stop-cock and gauge indicator enables operator at all times to regulate and control the water supply admitted to the drum.



FOR
SIDE
WALLS

FOR ROOF

The Shingles That Come in Bundles Already Stained Ready to Lay and to Last Longer Than Paint

We select Washington Red Cedar Shingles in random widths and cut [different dimensions. We treat these dried shingles by our special process of creosoting and coloring.

The finest earth pigments are ground twice in pure Linseed Oil and the highest quality Creosote Oil. The result is a permanent shingle stain with a preservative effect that makes "CREO-DIPT" Shingles last twice as long as brush-coated or painted shingles or natural wood and look better than any stained-on-the-job shingles you ever saw.

"CREO-DIPT" STAINED SHINGLES

12 Grades 16-18-24-inch 25 Different Color Shades

Every bundle bears our trade-mark name "CREO-DIPT." That is your safe-guard. We have a reputation to maintain. We are responsible for both the quality of the stain and the shingles—no wedge shaped shingles.

Write for pad of colors on wood.

If your regular dealer cannot supply you, we will supply you direct. The name of your architect would be appreciated.

We have special information for architects and builders about "CREO-DIPT" Shingles bent and sawed with wavy butts to produce that thatched effect. We have an attractive proposition for Lumber Dealers in unoccupied territory. Write at once.



Standard Stained Shingle Co.

1028 Oliver Street

No. Tonawanda, N. Y.



Residence of Mrs. Ida R. Kaplan, Summit, N. J.
One color tone on roof, another on side walls.
Architect, Nathan Myers, Newark.

You will get SPECIAL ATTENTION if you tell Advertisers you read American Carpenter and Builder.



Asbestos "Century" Shingles

"The Roof that Outlives the Building"

Your client's problem in building or roofing is to get *dependable material* — Roofing, for instance.

Asbestos "Century" Shingles are made of Portland Cement and Asbestos fibre, by the *patented "Century"*

process, which insures uniform texture, strength and durability. Roofing that you can *depend* on and recommend with a free mind.

You and every other wide-awake roofer and contractor ought to have the facts, terms and trade prices of these Shingles. Write for them.

KEASBEY & MATTISON CO., Factors, Dept. B., Ambler, Pa.

Branch Offices in Principal Cities of the United States

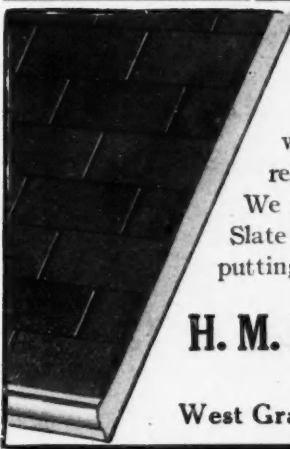

REYNOLDS ASPHALT SHINGLES

Guaranteed for 10 Years

will last many years longer—Natural colors of garnet, red, gray and green, which never fade.

We are the ORIGINAL MAKERS of Flexible Asphalt Slate Shingles and tested our product for ten years before putting it on the market. Let us send you a booklet.

H. M. Reynolds Asphalt Shingle Co.

Established 1868

West Grant St. GRAND RAPIDS, MICH.



Spanish Tile



The MOESCHL-EDWARDS CORRUGATING CO.

EVERYTHING IN SHEET METAL BUILDING MATERIAL

COVINGTON, KENTUCKY

Catalogue "S" showing a complete line of Ornamental Roofings mailed free to Architects, Contractors and Carpenters . . .

Write for Prices on

Ceiling Marquise
Columns Roofing
Cornice Shingles
Cresting Siding
Culverts Skylights
Finials Spouting
Garages Tanks
Gutter Ventilators

Address The Moeschl-Edwards Corrugating Co.

Covington, Kentucky

You will get SPECIAL ATTENTION if you tell Advertisers you read American Carpenter and Builder.

A roof to be proud of, Mr. Builder

If every roof you laid stood up under the fiercest attacks of winter and summer weather; if it made the home owner a "booster" for you—think how well it would advertise you and how much new business it would bring your way.

And there is a way to be sure that every time you lay a roof you add to your reputation. It is to roof only with

Flex-A-Tile Asphalt Shingles

Snow, rain, zero weather, midsummer heat—Flex-A-Tile is proof against them all. Indestructible asphalt, from the heart of the Rocky Mountains, and carefully selected chipped slate or granite combine to form a shingle that is not affected by the attacks of the elements. Comes in the soft, natural colors of the slate and granite. A wide choice of beautiful decorative effects.

Send for a sample of the Flex-A-Tile Giant—a new Flex-A-Tile Shingle.

The Heppes Co.

Also manufacturers of Asphalt Roofing in any finish, Asphalt Paint and Utility Wall Board.

1010 45th Ave., Chicago, Ill.

These mixers are made in sizes adapted to large or small work, and contractors wide awake to opportunity should examine the claims made for them. Mixers of this type will be on exhibition at the Chicago Cement Show. Correspondence is invited and circulars sent free by the Raber & Lang Mfg. Co., 810 Mill St., Kendallville, Ind.



New York Headquarters for Wood Working Machinery

The P. Pryibil Machine Company have inaugurated a permanent exhibit of new and rebuilt wood working machinery at 512 to 524 West 41st St., New York City. They are carrying a full line of representative wood working machines, both new and second hand. This is said to be the largest showing of wood working machines in New York City. Contractors and other users of such machines will find it very easy to run in and look over this line. The location is central, accessible to all depots, ferries, etc.

The company have established this exhibition in a building right next to the factory where P. Pryibil has for the past 60 years been manufacturing wood working machinery.

One of the leaders in the Pryibil line is the Parallel swing saw No. 5, shown in the accompanying illustration. The claim is made that this swing saw is different from all others. The saw travels in a straight line parallel with the table. This feature, combined with its general construction, produces a machine which has the following advantages:

1. A saw 3 inches smaller in diameter than required for any ordinary swing saw can be used, or in other words, when using an 18-inch saw on this machine, a 21-inch saw would be required on any ordinary swing saw machine.
2. Dado heads, grooving heads and wobble saws can be used for grooving, gaining, rabbeting, tenoning or moulding. It is of special advantage in gaining, rabbeting or tenoning, as the remaining margin is of the same thickness in all cases, irrespective of the thickness of the lumber.
3. A finish cut 34 inches long on stock 1 inch in thickness or less, equal to that made on a circular saw machine, can be made on this machine. On material thicker than 1 inch the length of the cut would be correspondingly shorter.

The P. Pryibil Machine Company cordially invite all AMERICAN CARPENTER AND BUILDER readers to pay them a visit and look over their machines when in New York, or to write at once for their illustrated price list.



Sand's Plumbs and Levels

Thirty years ago Mr. J. Sand started his life work as a bricklayer. He found it necessary in the course of his work to use an instrument that would be more useful than the old fashioned plumb stick with bob. So he made up his mind to make for his own use a level that would also serve the purpose for a plumb. He succeeded in producing a most excellent tool and it became so popular that his friends induced him to make a few for them, and this was the beginning of J. Sand & Sons, manufacturers of plumbs and levels.

The constant increasing demand of friends and fellow craftsmen for this plumb and level finally forced Mr. J. Sand to put up a small shop to supply the demand. Soon outgrowing the small shop, and his sons to assist him, he put up a factory with modern machinery and equipment.

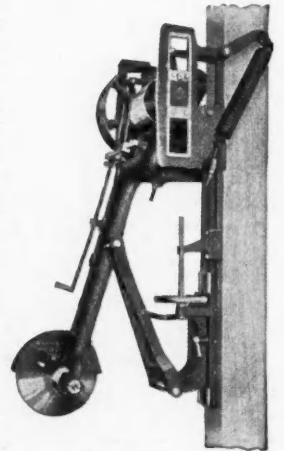

Parallel Swing Saw

You will get SPECIAL ATTENTION if you tell Advertisers you read American Carpenter and Builder.

**STILLWELL
CALIFORNIA
HOMES**
FOR ANY CLIMATE

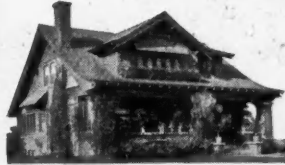

3 PLAN BOOKS FOR \$1

"REPRESENTATIVE CAL. HOMES"
50—\$1600 to \$6000—Price 50c

"WEST COAST BUNGALOWS"
50—\$500 to \$2000—Price 50c

"LITTLE BUNGALOWS"
28—\$300 to \$1500—Price 25c

128 Modern one and two story homes you can build with profit anywhere. Each book fully illustrated with photos, floor plans, descriptions, costs, etc. Send today. Money refunded if not satisfied.

E. W. STILLWELL & CO., ARCHITECTS
4193 HENNE BUILDING LOS ANGELES, CAL.

THE LATEST STYLES—REAL INDIVIDUALITY—PRACTICAL PLANS—NO WASTE SPACE—INEXPENSIVE TO BUILD—EASY TO SELL—BEAUTIFUL INTERIORS—BUILT-IN CONVENIENCES—SAVE HOUSE-
WORK.

THE ONLY ROOF THAT STAYS

THE ONLY ROOF THAT PAYS

RED
GREEN
PURPLE
BLACK

SHELDON'S SLATES

Cost no more than wood shingles. Outlast the building. No disadvantages. Used on new and old structures. Easy to lay; quick to obtain.

Post a Postal and Get Posted NOW

F. C. SHELDON SLATE COMPANY, Granville, N. Y.

Prestige THE REFLECTION OF Quality



**"METROPOLITAN"
METAL SHINGLES**

"The Metropolitan" is the same high grade as our regular shingles, but by being made in sheets containing six shingles, the cost is reduced, so they can be used in any sort of building, as they compete with wood shingles besides being much better.

They are made in Galvanized Steel, American Ingot Iron and Copper.

Milwaukee Corrugating Company
Branch—Kansas City, Mo. Milwaukee, Wis.

GOTHIC—Style "F"
Write for Samples and Full Information

**LEADS ALL OTHERS
for Safety**



West Bangor Slate

MANUFACTURERS of "man-made" roofings may talk fire-proof qualities, durability, beautiful effect, etc., but YOU know and WE know that without a doubt WEST BANGOR SLATE leads them all for safety. This slate will resist fire and all weather conditions longer than any other roofing material you can buy. A roof of WEST BANGOR SLATE will outlast the building itself.

Consider these things in preparing for the coming season. And remember that often a good slate roof costs no more than the "other kind." No painting, no repairs, make it the roof of "eternal satisfaction."

Let Us Send You Samples and Prices

Bangor Slate Mining Company
Trust Building BANGOR, PENNA.



**When the Owner
Pays Your Bill**



—assuming that you have roofed his house with our Genuine Bangor Slate—you will have made a good profit and a good friend.

The Owner will not be through with you, but will naturally recommend you to his friends. Thus your reputation will ripple through your entire section—your business and profits will grow.

On the other hand, suppose you give him a roof that sooner or later gives trouble; that puts the owner to further outlay for repairs, painting or renewal!

One sore customer can hurt you more than a dozen pleased ones can help you. Why take chances?

You have nothing to lose and perhaps much to gain, if you let us submit our proposition. Fill out and send the attached coupon today.

It will pay you to fill this out, detach and mail TODAY

February, 1914.

Please send me particulars about your ability to help me make more money.

Name.....
Address.....

**Genuine Bangor
Slate Co.**
Drake Bldg.,
Easton, Pa.
Easton, Pa.

You will get SPECIAL ATTENTION if you tell Advertisers you read American Carpenter and Builder.

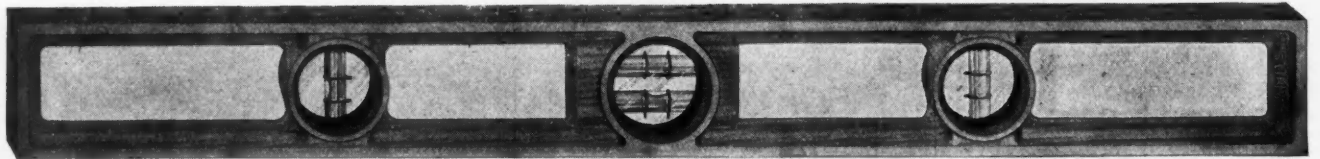

Sand's Aluminum Level—One of Their Popular New Models

Gradually J. Sand & Sons invented and perfected different styles of plumbs and levels, till today the variety is so complete that Sand's levels are the standard the world over and in demand by all the craft in need of good tools.

Their success is due to the fact that they have 30 years' experience as practical mechanics and 17 years as manufacturers. They know what wood to choose—old air-dried lumber—and they have it. It is left in their factory for a long time before being made into finished work. Wood that is merely kiln dried and then made into a finished level will never "Stand Up"—the changes of weather, dampness and rough usage to which every plumb and level is subjected to will affect it and make it useless.

The spirit glasses used in Sand's levels are their own idea. They have a slight crown, are very accurate and have a quick, responsive bubble. They are set in a manner to give the least amount of trouble and great efficiency. The wire center marks are very distinct. All spirit glasses are covered by heavy plate glass protecting them, also making those parts dust, dirt and water proof—in fact, Sand's levels have all the features essential to a high-grade tool.

The reputation of every bricklayer, mason, carpenter, etc., depends upon the class of work he produces. The selection of tools is an important matter. The natural trend of the mind of a good mechanic is to select the very best tools he can get, and this same painstaking care will tell in the

class of work he produces. A cheap tool is dear at any price. It does not look well, will not wear well and prevents the execution of skilled workmanship.

The Sand's plumbs and levels are made with the idea of producing a tool of high quality; a tool that will look right, last a long time and give the user satisfaction. They have a nice illustrated catalog describing these plumbs and levels which they will send on request. Address J. Sand & Sons, 1023-25 Rivard St., Detroit, Mich.



The Holland Furnace and Holland Service

We hear a good deal these days about service. It is the enlightened self-interest that has taught manufacturers that if they wish any real, permanent success they must deliver of honest worth just a little bit more than is expected of them.

Take the Service Department of the Holland Furnace Company, for instance. The Holland furnace itself is big value. No one could ask for more in a warm air furnace. But the manufacturers found that occasionally even a good furnace is poorly installed. Some man of little experience tackles the job and the results are disappointing. To overcome all likelihood of any trouble of this sort, the Holland Furnace Company early saw the wisdom of establishing a department, the sole duty of which was to advise with furnace

Shingle News ^{for} all Contractors and Builders

Before deciding on the kind of roofing material you intend to use this coming season, let us send you our booklet to help you settle the roofing question. Just drop us a postal card today and you will receive it by return mail, as well as a sample of our

BUCKEYE METAL SHINGLES

with

The Buckeye Raised Side Locking Joint

These easily represent the most advanced development in this line of roofing. They are decidedly different from anything on the market, and their many unique patented features will tend to revolutionize the metal roofing industry. At the same time, they are reasonable in price and we have special propositions for carpenters and builders.

Illustration below shows a section, full size, of the raised side locking joint. In contrast to all former types of metal shingles, this joint is formed entirely **above** the surface of the shingle, and a leak is therefore impossible. Buckeye Shingles are made in three beautifully embossed patterns, one of which is shown on the right. All are fully described and illustrated in our catalog. The raised lock joint produces a beautifully paneled effect and adds greatly to the strength and ornamental appearance of the shingles.

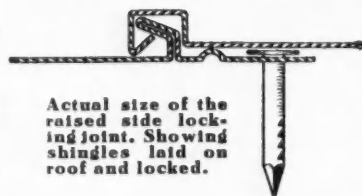

Actual size of the raised side locking joint. Showing shingles laid on roof and locked.

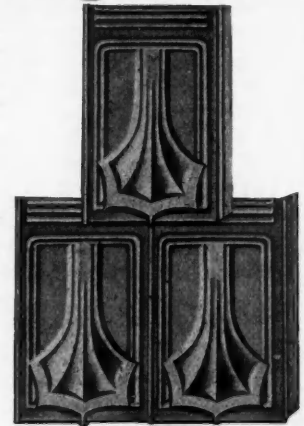

Made in 3 beautiful highly embossed patterns.

Be sure to write for our catalog and special proposition today.

The Thomas & Armstrong Company, Dept. A, London, Ohio

You will get SPECIAL ATTENTION if you tell Advertisers you read American Carpenter and Builder.

May We Send You This Book Free?

It's brimfull of helpful ideas on roofing of all kinds—wood, tin, tile, slate.

The 1914 edition of "Concerning That Roof" is a book that should be in *your* hands, because it gives vital facts about materials—the effect of fire, water, the elements and the flight of time.



CORTRIGHT Metal Shingles

mean satisfied owners — good-will — a help towards future business.

They are lighter than slate or wood, easy to lay, go on smoothly and quickly, require no expensive skilled labor.

More contractors each day are realizing

the folly of equipping a fine new building with anything but a storm- and fire-proof roof. They are laying Cortright Shingles with greater satisfaction to the owner, and profit to themselves. Say "Send me 'Concerning That Roof'" and it will come right along.

Cortright Metal Roofing Co.

Philadelphia and Chicago



—It Stays and Satisfies

VULCANITE ORNAMENTAL ROOFING

will without paint or repairs **outlast** any other roof covering. It costs less to buy and less to lay. Thoroughly fireproof and resists all weather conditions.

This roofing is laid in strips, one edge of which is cut in a shingle or slate pattern. It is durable and very decorative. Seven handsome, mellow shades to select from—colors which cannot fade because they are the natural tint of the crushed rock surfacing.

Vulcanite Ornamental Roofings are made in several artistic designs such as diamond-shaped tile effect, mitered slate effect, and V-edge effect.

Vulcanite Asphalt Shingles known under the trade name **Vulcantile**, are better than wood shingles. They last longer, are fire-resistant and do not crack or break. You forget roof troubles when you use any of the Vulcanite Roofings.

Write for Catalog and **FREE Samples.**

Patent Vulcanite Roofing Co.
2500 Ogden Avenue
CHICAGO :: ILLINOIS



G·F·T.

ROOFING SLATE

The Roof that Never Wears Out

DO you hesitate in choosing a roofing? Use slate — **Genuine Franklin Tunnel Slate.** It's the roof that will outlast any you have ever tried.

The hardness of Genuine Franklin Tunnel Slate makes it an ideal roof for city use, where the gas-laden air is most destructive to the average roof. Fire or any weather condition does not affect it. We stamp the slate with our trademark. Every "G. F. T." slate represents perfection in roofing slate.

No other roof lasts as long; no other roof is so substantial looking and beautiful. It satisfies. The first cost is positively the last.

Ask **NOW** for 40-Page, Complete Catalog and Price List.

SLATINGTON SLATE CO., Slatington, Pa.
(Established 1852)
Sole Manufacturers of G. F. T. Roofing Slate

You will get **SPECIAL ATTENTION** if you tell Advertisers you read American Carpenter and Builder.

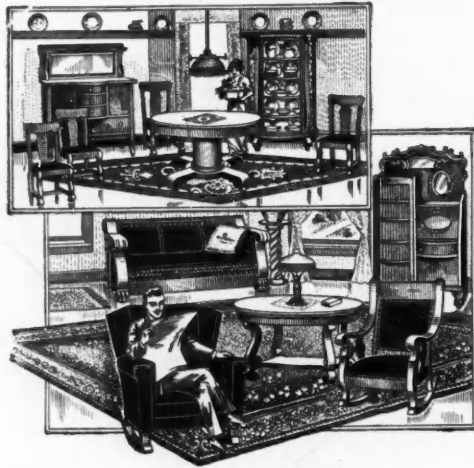

Carpenters' Homes Furnished on Credit

We furnish an average of 1,666 homes daily on this same new kind of credit—the kind that gentlefolks desire.

We ask no references, no contract, no security. There is no red tape. Simply ask for our catalog and your credit card will go with it. You will then have an open charge account and can order what you wish.

Just treat us fairly, and so long as you live you can buy what you want here on credit.

Pay 3 Cents a Day

Pay as convenient—a little each month. We allow a year to pay, but if sickness comes or loss of work we extend the time. You can furnish a whole home in a beautiful way by saving 2 or 3 cents a day.

All goods are sent on 30 days' trial. You keep them a month before deciding to buy. Any article not wanted can be returned, and we will pay freight both ways.

Save up to 50 Per Cent

We are enormous buyers—the largest in the world in our line. We buy whole factory outputs, and sell by mail alone. On hundreds of things you will find our prices about one-half store prices.

We guarantee to save you from 15 to 50 per cent under any cash prices in catalogs or stores. If we don't do that, return the goods.

Costly Book Free 5,112 Bargains

Our Spring Furniture Book pictures 5,112 home things, many in actual colors. This mammoth book costs us \$1 per copy, but we mail it free. It shows

Furniture	Silverware
Carpets—Rugs	Chinaware
Oilcloths, etc.	Sewing Machines
Draperies	Bicycles—Toys
Blankets—Linens	Cameras—Guns
Baby Cabs	Pictures—Clocks

We also issue a Style Book for women, showing 1,000 spring styles; a Dress Goods Catalog, a special Stove Book and a Jewelry Catalog.

Tell us which books you want. Use the coupon below. Your credit card will go with the book. Write us now, before you forget it.

Spiegel, May, Stern Co.

1354 W. 35th Street, Chicago

SPIEGEL, MAY, STERN CO.

1354 W. 35th Street, Chicago

(697)

Mail me free your **Spring Furniture Book**.
Also send me books marked below.

- Stove Book. Dress Goods.
 Watches and Jewelry.
 Spring Styles for Women.

Name _____

Address _____

Write plainly. Give full address.
Check which catalogs you want.

buyers and builders concerning the best way to install a Holland furnace.

The heating engineers in this department have had thorough and actual experience installing furnaces, and have learned how to make plans so clear and definite that any mechanic can follow them.

Wherever there is a house or other building to be heated, simply send the floor plans to the Holland Furnace Company, indicating what rooms are to be heated, and at once the service department engineers prepare their heating plans and detailed specifications. These show, also, just what each part costs delivered. Their organization makes it possible for them to return this full information very quickly. It is then easy to make a price on the job; and a contractor knows just what his profits will be before he begins.



The Holland Furnace

The Holland Furnace Company are making a notable offer just now for builders to act as their direct factory representatives. They have still some unassigned territory.

They claim and it seems reasonable, that the contractor and builder can do a neater and better job installing a Holland furnace with Holland service, than can the average tinner. Then why not have the profit?

Full instructions for installing the complete system are supplied with each outfit. In the fitting department at the factory they cut in all the collars, put in the dampers and supply adjustable pipe so that the desired length can be had without trouble. It is claimed that the installer of a Holland furnace supplied under their service system will not, in nine cases out of ten, even have to use a pair of snips to cut any pipe.

Hundreds of contractors and builders have already been delighted to find what a dependable high-grade furnace the Holland furnace is, and how easy it is to install. Write today for full particulars, addressing the Holland Furnace Company, Department AC, Holland, Mich.

You will get **SPECIAL ATTENTION** if you tell Advertisers you read **American Carpenter and Builder**.

You Can Burn Soft Coal Without Smoke in a KEWANEE Smokeless Firebox Boiler

That fact is being proven every day by building owners everywhere who are using these boilers. And here is another fact. A dollar spent for bituminous coal buys more heat than the same money spent for anthracite. That means a smokeless boiler burning soft coal uses less coal (figured in dollars) than an ordinary boiler burning hard coal.

We can and will gladly tell you of many installations where Kewanee Smokeless Firebox Boilers are cutting coal costs.



KEWANEE BOILER COMPANY

Kewanee, Illinois

Steel Power and Heating Boilers, Radiators, Tanks and Garbage Burners.

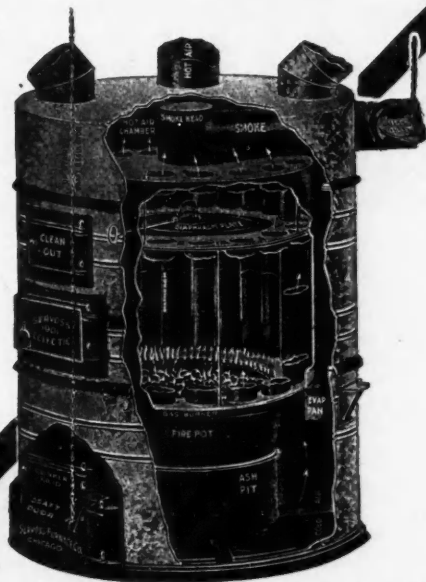

Don't Take a Chance With Heating Equipment

A few dollars, more or less, spent on your own or your client's heating equipment means the difference between "Adequate Heat—Heat Satisfaction" and "Cold Houses—Heat Dissatisfaction." Furnace Heat is recognized to be the most healthful, and the right kind of a furnace properly installed is cheaper both in first cost and future upkeep.

Servoss Tubular Furnaces are different from all others. Our tubular construction gives more radiating surface than is found in any other furnace. This means **economy in fuel** and **greater heat production.**

SERVOSS FURNACE means "SERVICE FURNACE"

We want every reader of this paper to know all about SERVOSS TUBULAR FURNACES. To know WHY they burn less fuel; WHY all our thousands of users are more than satisfied.

A SERVOSS FURNACE FOR EVERY HOME

Whether it is a mansion or a modest bungalow, we have a furnace that will meet all requirements. We have been building and installing SERVOSS TUBULAR FURNACES continuously for 40 years. Don't buy any furnace until you have thoroughly investigated its merits. Send in coupon today and get our Furnace Book.

"Send us your plans and we will give you an estimate on your heating equipment including furnace, piping, registers and fittings."

SERVOSS FURNACE COMPANY

115 West Lake Street

CHICAGO, ILLINOIS

MAIL THIS COUPON TO US TODAY
 Servoss Furnace Co., 115 W. Lake St., Chicago, Illinois.
 Please send me your furnace book immediately and at no cost to me.

Name.....
 Address.....
 Town and State.....

You will get SPECIAL ATTENTION if you tell Advertisers you read American Carpenter and Builder.

High Honors for Ceresit

It is always a source of pride to any man when he receives an honor of some nature, and rightly because such honors are invariably well earned.

Ceresit Waterproofing Company of Chicago was the recipient of two rewards during the past year, both of which have been given on account of the merit of Ceresit Waterproofing Compound.

At the World's Exposition at Ghent, Belgium, the Ceresit Waterproofing Company carried off the Grand Prix. Within the past six weeks the International Exposition of Building Materials at Leipzig awarded their product a gold medal.



Layout for Model Woodworking Shop

Just at this season of the year when outside carpenter work has practically ceased because of bad weather, the contractor is having no little trouble keeping his men working. They must be kept busy at something indoors or they are liable to drift away during the winter. For this purpose, many contractors are equipping small shops to turn out material to be used when the building season opens in the spring. Such a shop also furnishes a place where the individual carpenter, contractor or builder can turn bad weather to a profit by getting out work ahead and turning out side lines of furniture, kitchen cabinets, chests, etc.

A plan for just such a shop is being mailed out to all who request it by J. A. Fay & Egan Co., 545-565 W. Front St., Cincinnati, O. This layout calls for a building 30 by 60 feet. The machine equipment consists of a No. 2 single cylinder surfacer, No. 1 variety saw, 254 hand planer, 270 hollow chisel mortiser, 50 band saw, 2 tenoner, 8 friezing machine, and accessories, such as grinders, filing room outfit, etc. All these machines are modern high duty tools, the same as used in the up-to-date factories. The arrangement of the ma-



270 Mortiser

chines shown in the plan gives ample room for handling the rough and finished work to and from the machines. Sufficient space is left to provide for any extra machines which may be required in the future. All machines are driven from a shaft running the length of the building and driven by an electric motor or gasoline engine.

The tools mentioned above will give some idea as to the kind of machines necessary in an ideal carpenter shop. However, machines of greater capacity may be substituted to suit individual needs, but for general work the above tools will be found sufficient.

Views of the 270 M. S. mortiser, 50 band saw, and 2 tenoner used in connection with this plan are shown here-

Going to Build Remodel or Repair?

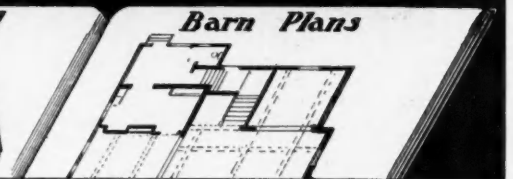

THESE TWO GREAT BOOKS WILL REDUCE YOUR BUILDING EXPENSES

Everything you need in lumber, millwork, hardware, roofing, paint, etc., is quoted in the Building Material Catalog at factory prices. Why pay high prices when you can buy direct from us, save money, get prompt deliveries and highest quality material.

Our Plan Book shows views of some of the most attractive houses, bungalows, summer houses, barns and garages ever built for the money. It also shows how you can obtain floor and elevation plans free.

Both books are FREE. Write for them TODAY.

Thousands have bought of us and saved money. Why not you? Get the books and see what this means to you. I will quote prices on all material needed, freight paid to your city. Everything guaranteed to be brand new—no wreckage. Everything guaranteed to satisfy you or you get your money back.

I will give you new ideas on floor plans—finish—panel and glass doors—windows—exterior and interior trim—paint color schemes, etc.

H. B. MUNGER, Pres.



CHICAGO MILLWORK SUPPLY CO.
AMERICA'S GREATEST SASH AND DOOR HOUSE

1422 West 37th St., CHICAGO, ILL.

You will get SPECIAL ATTENTION if you tell Advertisers you read American Carpenter and Builder.



Get My Latest Engine Offer

Let a WITTE earn its own cost while you pay for it. Take full 60 days' Free Trial to prove its big value.

Five-Year Guaranty

I unqualifiedly guarantee every WITTE engine for five years against defects, and consequent faulty operation. I carry the risk, as I have done for my thousands of customers during 27 years. Ed. H. Witte.

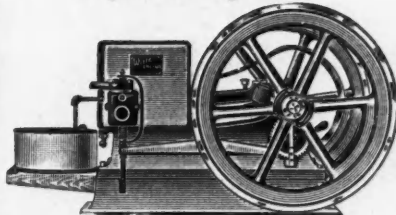

WITTE Engines

Kerosene, Gasoline, Distillate, Gas

All styles 1½ to 40 H. P. Used and recommended by shop, mill, and factory men all over the earth. All my life I have been a shop man, making my own engines. I sell only what I make. That is why, for 27 years, WITTE engines have always made good and stay good.

Look at These Prices!

4 H. P.,	\$ 75.50
6 H. P.,	99.35
8 H. P.,	139.65
11 H. P.,	208.90

Other sizes proportionately low. WRITE FOR MY FREE BOOK, and all about my New Liberal Offer BEFORE you arrange to try any engine. I save you money, besides giving you the easiest chance to get the best engine service. Write me to show you.

ED. H. WITTE, Witte Iron Works Co.
1779 Oakland Ave., Kansas City, Mo.

This is the Novo Outfit for Pumping against Pressure

Whether needed for domestic, city, factory or railroad water supply system.

It is back-gearred to the famous Novo Engine and forms a very compact, rigid outfit. Both engine and pump are mounted on a cast iron base, insuring perfect alignment and quiet running of gears.

The cylinder is brass lined, the piston-rod brass cased and valves are easily reached. These outfits come in nine sizes, with capacities of from 790 to 4,300 gals. per hour. They include Novo Engines of from 1½ to 6 h.p.

Send for the Novo Book, "Reliable Power"

Become familiar with the big line of Novo Engines and Hoist and Pumping Outfits. Novo Engines are made in ten sizes, 1 to 15 h. p., and are the lightest engines for power developed.

NO LANK
NO FAN
NO FREEZING
TROUBLE.

Novo Pump Fir.
1401 Pumping
water to Country
Estate.

NOVO ENGINE CO.

CLARENCE E. BEMENT,
Sec'y and Mgr.

441 Willow Street,
Lansing, Mich.

NOVO
REG. U.S. PAT. OFF.
ENGINES
AND OUTFITS



WHO PAYS? WHEN THE ENGINE STOPS

Surely not the mixer manufacturer—or the people who build the engine.

You Know very well that every time your engine coughs a few times and stops, you are the one who foots the bill. The wages of a dozen or more men idling around comes out of your pocket—and all of this time, with your crew looking on, you fume and fuss with your engine.

You can reduce engine troubles and delays to the minimum by using and insisting upon

The "New-Way" Air Cooled Engine

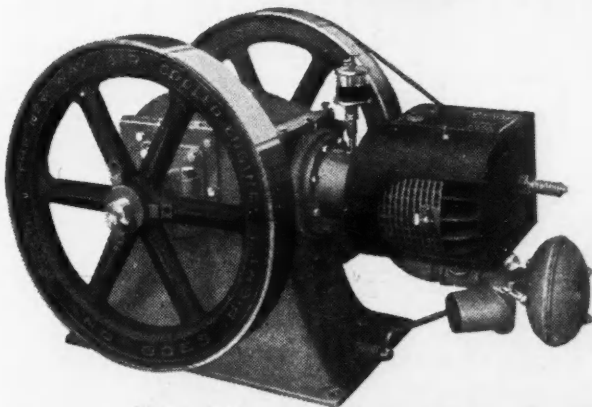

A high class quality engine of few parts, such as a blind man could use and would indorse.

Over nine thousand "New-Ways" are in successful operation on mixers and other power machinery.

We have some mighty interesting facts which you, as a user of power, should know about.

Something new in the engine line that is up-to-the-minute.

Write at once for further details
:-: and let us figure with you :-:

Get Catalog X

THE "New-Way" MOTOR COMPANY
LANSING, MICHIGAN, U.S.A.

Write Today

You will get SPECIAL ATTENTION if you tell Advertisers you read American Carpenter and Builder.

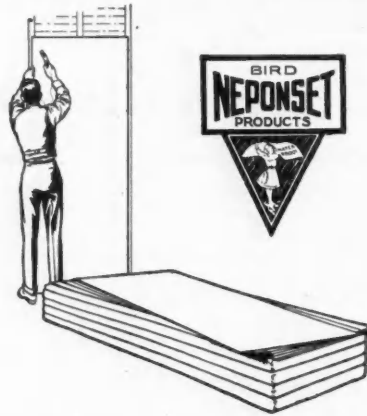

Winter Profits

This winter you can do a nice business building partitions, finishing off or remodeling rooms with

NEPONSET WALL BOARD

You have probably seen our advertising to House Owners in which we have told them to "fix up their house this winter" with NEPONSET Wall Board. Remember this—NEPONSET Wall Board is waterproof and finished. It does not require decoration. The whole job is yours.

BIRD & SON

EAST WALPOLE, MASSACHUSETTS
21 RIVER STREET



New York Chicago Washington
Portland, Ore. San Francisco
Canadian Plant, Hamilton, Ont.

with. The 270 is a small sized machine, taking chisels up to $\frac{3}{4}$ -inch square, but will make any size mortise by overlapping. The mandrel is stationary, the work being carried into the cut by the table, eliminating the breaking of small chisels. The 50 saw is square column type, which will do

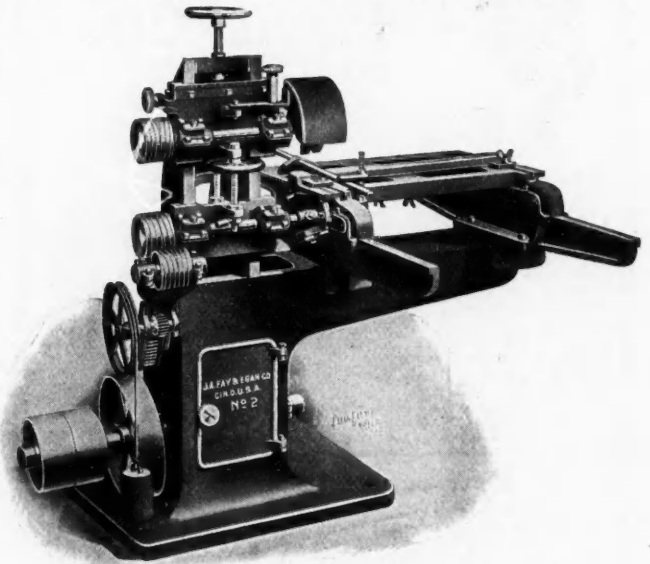

2. Tenoner

more work at a lower blade cost than the old "goose neck" type. It has 36-inch wheels and does equally good work on heavy and light work. The knife-edge straining device is used on this machine, permitting the use of thin blades without danger of breaking. For single end tenoning in a carpenter shop, the No. 2 has sufficient capacity. It is one of the standard line of Fay-Egan machines, built on high duty machine tool principles, to produce the best work at a low cost.

Descriptions and illustrations of other machines for use in carpenter shops will be sent upon request to J. A. Fay & Egan Co., Cincinnati, O., together with the layout plan.

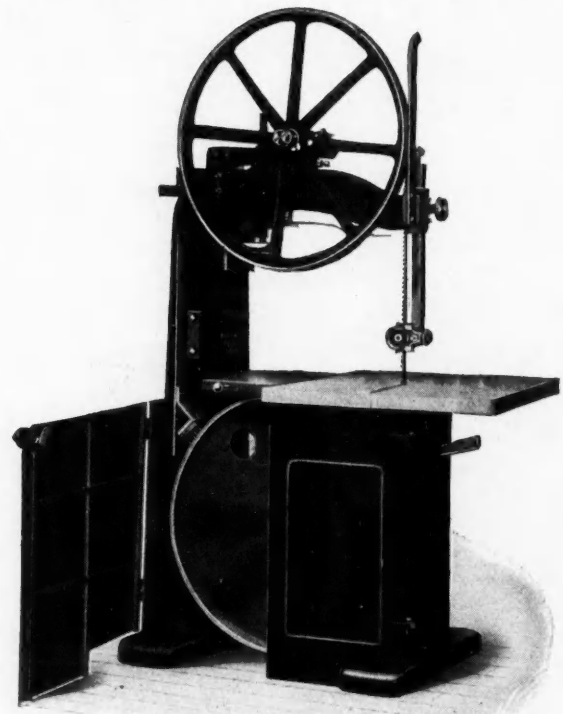

50 Band Saw of J. A. Fay & Egan Line

You will get SPECIAL ATTENTION if you tell Advertisers you read American Carpenter and Builder.

Straight Talks on Durametal Weatherstrips

¶ You contractors—carpenters and building owners—why not buy weatherstrips direct from the manufacturer and do your own installing?

¶ By our unique-plan, we have cut out the usual big selling expenses, which enables you to buy direct from us, make a profit on the strip and good money on the installation besides.

¶ Durametal Weatherstrips have been successfully sold for over 10 years and have stood every possible test. Their durability and simplicity makes them superior to all others.

¶ Made of best heavy zinc, and fully guaranteed. Write for samples and prices now before you turn another page. There's money in this for YOU.

A few agencies open to responsible, live, local contractors and carpenters.

Durametal Weatherstrip Co.
829 W. Washington Blvd. CHICAGO, ILL.

New Typewriter \$18

in U. S. A.

Mistakes are costly! Write your bills of material on the **BENNETT** Portable Typewriter—then you *know* that your order won't be held up because it cannot be read. No chance for mistakes, with everything in clear, easily read type.

Be business-like—it pays!

You can write your tender of bids, contracts, contracting estimates, time sheets, bills, and all your correspondence with prospects; to hardware merchants regarding tools, etc., clearly and quickly on this wonderful little typewriter and save a lot of your valuable time. Keep a record of *everything* you write. The Bennett makes legible carbon copies.

Serviceable—Portable

The Bennett is a serviceable typewriter that is as easily carried as a book. Weighs but 4½ lbs. Does work of \$100 machine—you save \$82. Low priced because simple. Has only 250 parts, other typewriters have 1700 to 3500. Built in the same factory by same men who make Elliott-Fisher Billing and Adding Machines, selling at \$175 to \$1000. Has standard 84-character keyboard, reversible ribbon, marginal release, etc. Prints lines perfectly straight—writing always in plain sight.

Over
33,000
Bennett's
in use



Agents
make
good money
selling
Bennett's

Write for our catalog today

Let us prove that you can use the Bennett in your everyday work. We will send you this mechanical marvel under a money-back-unless-a-titled guaranty. Test it thoroughly for ten days—if not all we claim, and more, return it to us.

GEO. G. BENNETT CO., 3301 Cedar Street, Harrisburg, Pa.

LOOK! CARPENTERS—CONTRACTORS—BUILDERS

At a machine that for general use in the shop or on the job does not have its equal.

We call your attention to the following features:

A Rolling Table for Cut-off and Mitre Work—so easy of operation that with a 1000 pounds weight on it, can easily be worked back and forth with the pressure of one finger. Can be instantly locked for ripping or beveling. A wide removable throat for use of Jointer or Dado Head. An Extension that allows you to easily work 18' lumber.

A Boring Attachment that has a longitudinal movement of the bit.

The Double Arbors will carry 19" Rip and Cut-off Saws or Dado Head—allowing you to change instantly from one to another. Capable of doing any sawing from the finest inside finish to timbers 7" thick. We have agencies in every prominent city in this country and abroad. Write for Catalogue.

BEACH MFG. COMPANY

Montrose, Penna.

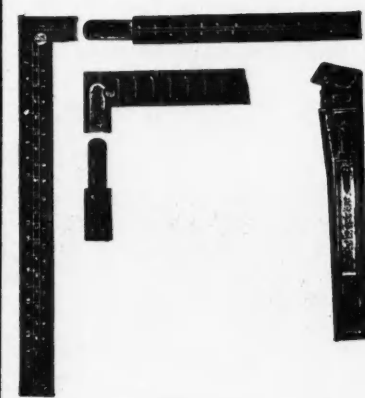

This is the
**Standard
Take Down
Square.**

It makes
good with
the user.
Send and
know
more about it.

**Southington
Hardware Co.**
Southington, Conn.

THE NEW FOX JR. FLOOR SCRAPER

Fully Equipped
Weight 70 Lbs. **\$15**
Full Satisfaction Guaranteed.

For further information address postal card to

FOX SUPPLY CO.
BROOKLYN, WIS.



You will get SPECIAL ATTENTION if you tell Advertisers you read American Carpenter and Builder.

Good Furnace Book to Have

We have received from the Campbell Heating Co., Des Moines, Iowa, a worth-while furnace catalog and instruction book, "Twice-a-Day," which describes the Winter Chaser furnace. According to it, the most important features of Campbell construction are:

1. The water reservoir. This stands inside the furnace, and the air as it is heated and expanded automatically drinks from the moisture evaporated from this tank. According to Dr. Evans of the Chicago "Tribune," the air at all times in a home should have 50 per cent humidity. They furnish this with the automatic moisture inside of the warm air jacket. Of course, the amount of air evaporated depends entirely upon the temperature of the outside air. If it is cold, more fire is required, and the expansion of the cold air is greater because of the lower temperature at which it starts. Usually anywhere from two to eight gallons a day are evaporated.

2. The large air chamber of jacket. This reference is to the space around the furnace inside of the jacket, which space is used for heating air. This space is from five to ten times as large as the air space around the ordinary furnace, consequently it will hold five or ten times as much air; there is never any danger of burning the air, of scorching it, its vitality is not destroyed and there is no danger of setting a house on fire. To correspond with this big air chamber, the manufacturers have to furnish the large pipes and large registers so as to carry the air from the furnace quickly and put it into the rooms where it is wanted, and consequently there is no heat lost in the basement.

3. The entrance door in the jacket. As before mentioned, this air chamber is extremely large. Large enough so that a man can step through the entrance door into this air

chamber, can pass around the furnace at any time that he wishes, can examine the furnace for any repairs which might be needed, and can clean out the air chamber. With the circulation of air there is always a circulation of dust. The dust is carried into the air chamber and there it lies and is from time to time stirred up and carried back into the rooms. This accumulation accounts for the dirty wall paper, dirty curtains, etc., which are so common with furnace heating, and which no doubt you have noticed a great many times. It is because of this accumulation of dirt inside of the air chamber that furnaces are usually called dirty. There is no reason why the air chamber should be allowed to become filthy. You would not allow your piano to stand for five, six or seven years without its being dusted, and there is no reason why your furnace, in fact, the entire air chamber and pipes, should stand without a cleaning. You would think it was dreadful neglect to let a piano stand in this way, and yet the air which you breathe is very much more important than the dirt on the piano and yet so little care is taken with the air chamber of the furnace.

4. The steel which is used in the construction of the Campbell system is thick. Also this material is selected; they have used the same material for a great many years. When you take into consideration that they have a great many furnaces which are more than 20 years old, and some which are thirty years old, you will realize how important it is that this selection should be carefully made. You will also be surprised at the great number of furnaces which are taken out after being used two, three, four and five years. In fact, the average life of the ordinary furnace is about four years. A few burn out sooner, and a few last a year or two longer. However, that the weight of the steel is not the only feature, which accounts for the great durability of the Campbell system.

Cement Coated Houses Should Be Waterproofed

The seepage of rain water and melted snow into the cement coating or stucco causes that streakiness and discoloration that gives so much dissatisfaction.

This seepage is also the cause of cement coatings disintegrating and crumbling off

the wall. In summer the coating is saturated by rain one day and dried the next. In winter it is frozen at night and thawed during the day. The alternate expansion and contraction quickly destroy the coating. By properly waterproofing the cement you can prevent this.



THE PERFECT WATERPROOFING COMPOUND

Was used for waterproofing the cement stucco coating on the handsome country residence of Mortimer L. Schiff, at Oyster Bay, L. I., N. Y. (see cut). It was also used to waterproof the swimming pool in this residence. It has been thoroughly successful in each case.

Ceresit is a demonstrated success for waterproofing concrete or cement mortar as well as stucco. It is used in basements, on roofs, on walls, in fountains—any place and every place where dampness or water are met.

Ceresit waterproofs thoroughly and permanently. It needs neither expert labor nor extra labor. It has no odor. It does not discolor.

If you will give us your dealer's name we will send you our catalog, the "Book of Evidence."

Ceresit Waterproofing Company

910 Westminster Building

CHICAGO, ILLINOIS

FACTORIES—Chicago; Unna, Germany; London, Paris, Vienna, Warsaw

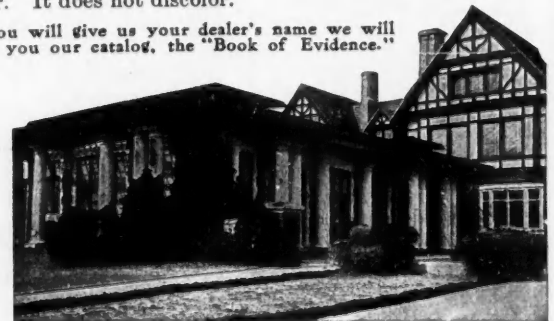

You will get SPECIAL ATTENTION if you tell Advertisers you read American Carpenter and Builder.

They Ventilate From the Ground Up



Foul air must be drawn from the building and fresh air substituted. Cupolas do not ventilate. The cross currents drive the foul air back and the wind entering creates draughts. Besides dampness, snow and rain can get into the building through a cupola.

ROYAL VENTILATORS

draw the impure air upward and outward from all parts of the building because they are purposely made to do this. The process of exhausting foul air and substituting pure air goes on without interruption of any kind. No wind, rain, sleet or snow can enter the building through the Royal. It keeps up a constant circulation.

You can rely on Royal Ventilators. Made from heavy gauge galvanized iron or copper as desired and thoroughly guaranteed. They are rust-proof. Service and efficiency have placed the Royal far ahead of all other ventilators.

WRITE FOR CATALOG

ROYAL VENTILATOR CO.
417 Locust St. PHILADELPHIA, PA.

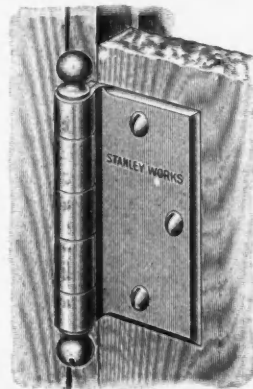

Stanley Ornamental Surface Butts No. 165

Save Time and Labor and Please the Owner

The Ornamental leaf screws on the surface of the door, saving half the time of mortising. The slotted ball tip can be unscrewed and the pin reversed so that the butt can be used on either right or left hand doors.

The handsome, dignified, **Beveled Edge** design harmonizes with the popular designs of hardware. Made in all finishes

Write for Booklet "A" describing this and many other lines of "Stanley" Quality Hardware.



The Stanley Works
New Britain, Conn



Draw Knife
No. K10
Price \$1.50

This Draw Knife is All One Piece

This fine draw knife is the only *one-piece* draw knife made. *It has never been successfully imitated by anyone.* It has the perfect balance that puts the right pull in your hands for a wafer-thin pine shaving or a big bite out of tough oak. Try it out like we ask everyone to try out all

KEEN KUTTER Tools

on a make-good basis—if it isn't all we say in quality and workmanship, the dealer is authorized to refund the price paid for it. This applies to any tool or piece of cutlery that carries the world-famous Keen Kutter trade mark.

If not at your dealer's, write us.

SIMMONS HARDWARE COMPANY
St. Louis New York Philadelphia Toledo
Minneapolis Sioux City Wichita

Draw Knife, No. KGF—German Pattern—8 in. Price \$1.25

ANOTHER TIME SAVER!



Drive in the lugs. Set 4 screws.
Hangs from top—hinges from side

on
Half or Full Length Screens

SAMPLE SENT ON REQUEST

WATROUS MFG. CO., DES MOINES IOWA

You will get SPECIAL ATTENTION if you tell Advertisers you read American Carpenter and Builder.

How to Make More Money Building Barns

Every man in the building business can have the benefit of W. D. James' barn knowledge and use it to his own advantage and profit. There's more money in building up-to-date, properly equipped barns on scientific principles than in putting up the old type. The right kind of a barn means an enthusiastic owner, and that means more jobs in the same neighborhood.

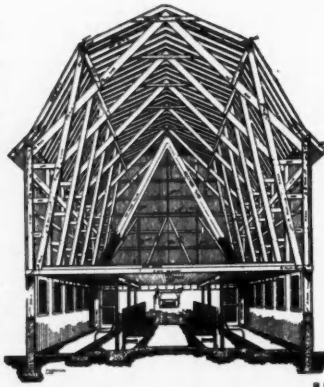

Get Our Special Blue Print and Building Service Offer

Mr. James is the foremost authority on dairy barn building, and he wants to make you a special offer of complete working blue prints of several practical dairy barns of different sizes and types. In addition to Mr. James' personal co-operation, you can have help from our architectural department, conducted by experts. Write today for all the facts regarding this service.

James Manufacturing Co.

A. H. 75 Cane Street

Ft. Atkinson, Wis.



This Valuable Book Free

—tells about new and better construction—lighting—size—site—drainage—general equipment—King system of ventilation; gives floor plans of successful barns. Your copy—**Free**—if you answer these questions: For whom do you expect to build or remodel dairy barns? (Give names and addresses). When? For how many cows? Send your application now for book and complete information.

Never Rattles

IF you've never used **Con-Ser-Tex Canvas Roofing**, we can't expect you to know all about it. But listen.

We've prepared a nice book of samples that we want you to have. These samples show different widths and different weights of **Con-Ser-Tex** for different purposes.

Con-Ser-Tex Canvas Roofing can be used as **roof** or **floor** for any porch, deck, balcony, boat deck or porch roof. It will stand rain, shine or wear equally well; can be walked on; never rots; never tears; never scuffs; never mildews; never lets water or moisture through.

Get your book of samples now. It's **FREE**. Let us tell you more about **Con-Ser-Tex**. You as a Carpenter or Contractor will see for yourself just why you should use it. That there's an advantage in it for you, we can see. We want you to see it too.

A Postal Card Today. **DON'T FORGET.**



William L. Barrell Co.

8 Thomas Street, NEW YORK CITY

Chicago Distributor: Geo. B. Carpenter & Co., Wells and Michigan Sts.

California Distributor: Waterhouse & Price Co., San Francisco—Los Angeles

Are You Missing Something?

You are if you are not on the mailing list of the Richards-Wilcox Mfg. Co., Aurora, Ill., to receive their little illustrated monthly magazine, "DooR-Ways."

The January number is better even than usual. There is an article on flush doors of the multiple sliding type fully illustrated with working drawings, that every builder ought to study. Architects will find "DooR-Ways" a very interesting and instructive little school master on the proper hanging and detailing of all forms of sliding doors.

The Richards-Wilcox Mfg. Co. will gladly send "DooR-Ways" to any one who will write them for it.



Sanitary Chemical Closet

Builders constantly face the problem of sewage disposal where no sewer or running water is available.

The Sanitary Chemical Closet Company, Inc., of Bradford, Pa., has a closet system which uses a powerful chemical

resolvent on the sewage, killing all germs and eliminating all odors. With this system the outdoor open closet and cesspool and the attendant discomforts and disease dangers are entirely eliminated. This system is accepted by health and sanitary authorities and has been installed in a great many homes, schools, factories, parks, summer resorts, railway stations, etc., where sewer facilities are not available. Running water is unnecessary.

The system is illustrated herewith and its simplicity can be seen at a glance. There is absolutely nothing to get out of order. The chemical need be renewed only once or twice a year and the cost of maintenance runs from \$2 to \$4 a year, which makes it a great deal

cheaper than a water system. Installation is easily made, and the system can be quickly added to any building at a small cost. The closet bowl looks exactly like a regular sewer water closet.

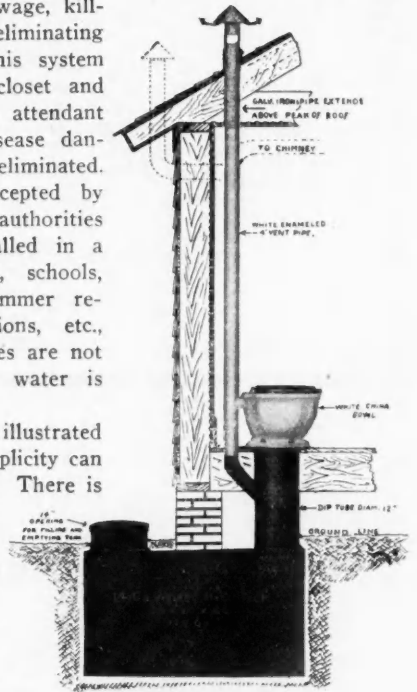

Section through wall showing chemical closet installed



MAPLE FLOORING

Thoroughly kiln-dried, side and end matched, hollow backed, bored for blind nailing, and **STEEL POLISHED**. Guaranteed to give best results under hard continuous wear.

Do not be satisfied with ordinary flooring. You can get **DIAMOND HARD MAPLE FLOORING**.

You'll receive full value in wearing service and permanent finish.

Write us. We'll Tell You More.

J. W. WELLS LUMBER CO.
Menominee, Michigan

The Newest Carpenter Tools

All Steel

Wgt. 4 lbs.
Jaws 28" long
Folds in space
14 1/2 x 2 x 2"

**NO SHIFT
FOLDING
SAW VISE**
Price
Prepaid,
\$1.60
in U. S.
(Folded)

Price
Prepaid,
90 cts.
in U. S.

All Steel BUCKEYE SAW VISE
Jaws 14" Long
Wgt. 2 lbs.

These are the easi-
est and quickest
adjusted planes on
the market.

They are guaran-
teed not to tear
out, chatter or
clog. Even when
used against the
grain in the most
difficult wood.

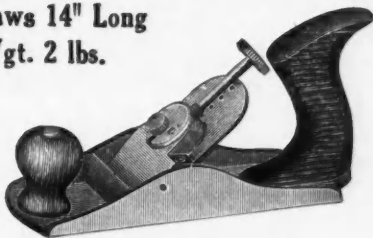

BUCKEYE PLANE

Smoother, Price \$2.00; Jack, Price \$2.50;
Fore, Price \$3.00. Prepaid in U. S.

Ask Your Dealer, or Order Direct.

Buckeye Saw Vise Co., 2050 W. 55 St.,
CLEVELAND, O.

Why Pull-Easy Nail Collars Are Money Makers

These little steel devices are big money making devices for the carpenter or contractor,—saving lumber, nails and labor.

When these collars are used with nails on runways, falsework, scaffolding, forms and other temporary structures, there is no tearing apart of lumber, knocking out, or digging for embedded nails. The head of the nail protrudes from the wood and is always ready for the claw of the hammer or nail puller.

PULL-EASY

(Patents Applied for.)

"THESE LITTLE COLLARS SAVE DOLLARS"

slip quickly on to any nail from 8d to 20d. They will not crumple or break, and by their use lumber and nails can be used over and over again.

Pull-Easy Nail Collars are put up in convenient packages for your use. They are clean, light, handy, and they do save a lot of money. If your dealer does not handle them, write today for sample.

PULL EASY MFG. COMPANY
22 Barstow St., Waukesha, Wis.



The Old Way.



The Pull-Easy Nail Collar Way.

\$2430.00 IN 90 DAYS

\$27 A DAY actual clear cash profits is what one man made in just three months with a Helm Press in a little town of 375 inhabitants. He saw a big opportunity in manufacturing pressed cement brick and blocks, was quick to grab it and is realizing big money now. Look round about you. See how concrete is taking the place above all other materials in building construction. Realize what a chance is yours now to get in this big industry on the ground floor. \$20 to \$50 a day profit is easily made with the Helm Press. You will be turning out a product that is as staple as sugar, as much in demand as the clothes on your back.

Ten Billion Brick

are used every year in the United States. Thirty-three and a half million every working day of the year. Consider how enormous the demand, how contractors are crying for more brick. Be the one to supply this demand in your locality. You can start in this business. Be a manufacturer of pressed cement brick and make money from the start. No experience is necessary and very little capital needed.

There are Big Contracts with their Big Profits ready for You

No matter where you are, how little the town or how big the city. Builders are turning to this product because it solves the problem of high cost of building. Concrete must take the place of wood, stone and clay. Here are experiences which you can duplicate in your community:

I landed a \$90,000 government contract with Helm pressed cement brick.

Just landed a contract for 400,000 Helm pressed cement brick. We are working on a contract for half a million pressed cement brick.

Made a million brick this season on one of your Helm presses. My daily manufacturing profits on pressed cement blocks average \$25.

Working on a contract for a quarter of a million pressed cement brick.

Made 17,000 pressed blocks for one contract in less than a month.

Six weeks behind on Helm pressed cement brick and block orders.

We want you to know more about these manufacturers who are landing the big business and making the big money. We want to show you how they started with but little capital.

FACTORY OWNERS are the biggest money makers in America and this machine will place you in their ranks. You can start with little capital and even without experience. This is the machine for you because it makes pressed cement brick and blocks under 80,000 pounds pressure. No tamping, and easy work. It makes 1,000 blocks or 10,000 brick daily. No burning required. Ready for the market in a few days' time. Eventually someone will make pressed cement brick and blocks in your community, but now the opportunity is yours. No matter if cement products are now made there—these brick and blocks made by pressure will be demanded. The possibility of failure in this business is almost eliminated. You can enter it with almost a dead certainty of meeting success. Costs you nothing to learn all about it. Fill in the coupon here, mail it today, and receive free, full information of the Helm Press and the money to be made in the cement brick business.

Helm Brick Machine Co., 172 Bank Bldg, Traverse City, Mich.

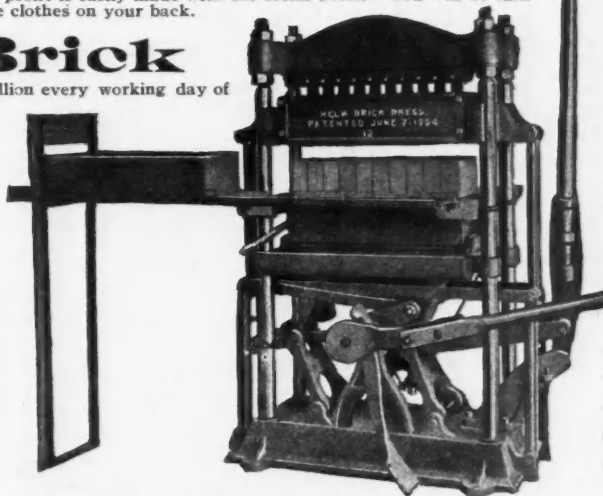

Helm Brick Machine Company,
172 Bank Bldg., Traverse City, Mich.

Please send FREE the book on
concrete and Helm Presses.

Name

Address

You will get SPECIAL ATTENTION if you tell Advertisers you read American Carpenter and Builder.

Metal Weatherstrips at Reduced Cost

A new method of distributing Metal Weatherstrips which promises to greatly reduce their cost to the consumer and which opens a profitable field for the contractor, has been inaugurated by the Duramental Weatherstrip Company of 829 Washington Street, Chicago.

Metal weatherstrips have for a long time received the endorsement of all the leading architects and builders in the large cities but, owing to the patented monopoly under which the industry has struggled and a very restricted selling system, the use of the metal strips has been confined almost entirely to the large cities.

The above company has now made it possible for anyone to buy this material by the foot and to install it either themselves or to have the work done by a contractor in their own town. By adopting the modern mail-order method of distribution, the selling expense is reduced so that now this important modern improvement is placed within the reach of home-owners, everywhere. This pattern of metal weatherstrips is not new or in any sense an experiment. Over six million windows and doors have been equipped with them in the larger cities and the field is now open for the equipment in six times six million homes in the smaller cities and towns where the cost in the past has been prohibitive except for the very wealthy.

Metal weatherstrips are made entirely of zinc or bronze—

metals which are not affected by moisture—and they are installed in such a way that they do not wear out, but last as long as the building itself. Any carpenter or handy man can soon learn to install them quickly and properly, and a profitable winter's business is to be secured by taking contracts for the work.

For doors, and for casement or hinged windows, highly tempered spring bronze is used, a narrow strip being placed in the crevice between the door and the door frame, so that it cushions against the edge of the door when it is closed.

A very attractive booklet describing and illustrating the equipment and the method of installation may be had on application to the above company.



"The Finishing Touch"

This is the very fitting title under which the readable little magazine travels which is issued by the Murphy Varnish Company, Newark, N. J. It is stated on the first page that the publication is a reminder that "Quality in varnish is economy in varnishing."

No one knows the truth of this slogan better than carpenters and builders. With mechanics' wages what they are today, the cost of varnish, even the best varnish, is so small a proportion of the total cost of any building that no one should think of ever using any but the best.

Pretty expensive economy, say we, to use a high priced workman's time flowing on "department store varnish."

"The Finishing Touch" is one of the newcomers among the several paint and varnish booklets. As it is full of sincerity and ginger, we predict a long and useful life for it. We understand copies of "The Finishing Touch" are being mailed out regularly to dealers, builders, and others interested in good varnishes.

	WINDOW GUARDS ELEVATOR ENCLOSURES
	Fences, Gates, Railings, and Wire Specialties.
	Send specifications for prices, etc. Write today.
	KOKOMO FENCE MACHINE COMPANY 502 North Street Kokomo, Indiana

Copper Bearing — Weather Wearing!

Actual weather tests have proved conclusively that Copper Bearing Steel gives superior service for roofing purposes. Our Copper Bearing Sheet and Tin Mill Products are designated by special markings, and for purposes of illustration we display two of our standard brands—Apollo and MF

COPPER BEARING Sheets

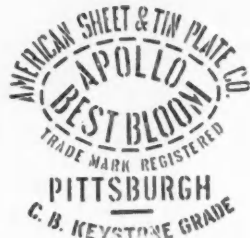

Both Black and Galvanized, are designated "C. B. Keystone Grade" added to regular brand, as indicated by the Apollo Best Bloom stencil above.

COPPER BEARING Roofing Tin



C. B. OPEN HEARTH
1 C
32 POUNDS COATING

Is stamped "C. B. Open Hearth" in addition to the brand and weight of coating, as indicated by the MF brand shown above. You should use no other.

American Sheet and Tin Plate Company

General Offices: Frick Building, Pittsburgh, Pa.

DISTRICT SALES OFFICES:
Chicago Cincinnati Denver Detroit New Orleans New York Philadelphia Pittsburgh St. Louis
Export Representatives: UNITED STATES STEEL PRODUCTS COMPANY, New York City.
Pacific Coast Representatives: UNITED STATES STEEL PRODUCTS COMPANY, San Francisco, Los Angeles, Portland, Seattle

You will get SPECIAL ATTENTION if you tell Advertisers you read American Carpenter and Builder.

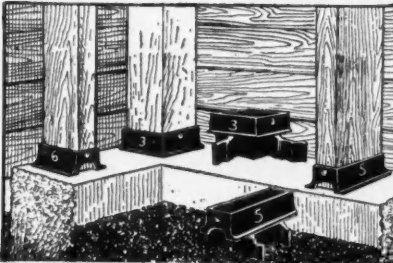

In Cement Floors and Cement Foundations

ROSS Iron Studding SOCKETS

The "100 year" Post Supports

Simply tap Sockets into soft Cement. No sills to rot! No toenailing to rust! You can make easy sales for Corncribs, Barns, Granaries, Hoghouses, Sheds, Garages, etc. Small stock will help you fill orders promptly. Good profits for you. **WE PAY THE FREIGHT.**

Write for **Free Booklet G. M. ROSS & CO., 1244 Broad Str. GRINNELL, IA.**

**Your
Customers
Will Use**

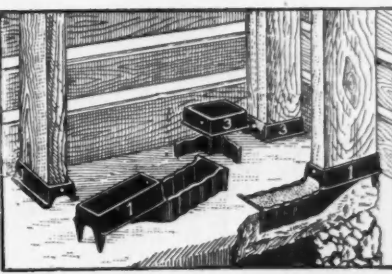

BIRCH

See our
adv.
in the
**DEC.
1913**
A.C.&B.

Before you decide on interior trim for your houses, investigate Birch. Birch is close-grained and hard—very durable. Takes a great variety of stains easily and permanently. Has a beautiful, rich figure resembling that of mahogany. Use Birch for all inside trim—doors, casings, base and floors. The best interior finish at the least expense.

Send
for
**FREE
BIRCH
PANELS**

Northern Hemlock & Hardwood Manufacturers Association
Wausau Wisconsin



No 24 - Desk
Bookrack on ends
Upper section for magazines
43 in. High
36 in. Wide

Easy-To-Make Furniture

100 designs drawn to scale by expert designers, easy to understand. Carpenters and contractors make one piece of furniture and save the price of the entire portfolio. Sent prepaid on receipt of \$2.00.

Satisfaction guaranteed or money refunded.

Crater & Holt

43 National Avenue
Grand Rapids, Mich.

Use Plastergon—and a Busy Spring is Certain!



You'll find your architect quick to specify Plastergon, if he's tried it out. And it's the test that tells. Plastergon's artistic possibilities are unlimited—equally adapted for modest cottage or costly home—and always at a surprisingly low cost.

PLASTERGON

Only Guaranteed Wallboard

Send for sample—and note its cream-white pebbled surface—unexcelled for painting, tinting or stenciling. You can get the decorator's profit, and plasterer's, too.

Literature and details of our money-making proposition sent on receipt of postal. Send it now.

PLASTERGON
(CREATED
WOOD FINISH)
WALL-BOARD

PLASTERGON WALL BOARD CO.
Dept. A. Tonawanda, N. Y.

There's Just One "Wood-Core" Wall Board

Its construction is shown by the border of this advertisement. Selected kiln-dried wood slats are laid edge to edge for the core. Heavy, specially prepared paper is cemented onto both sides, under enormous pressure. This patented construction makes



Trade Mark Registered, U. S. Patent, Office, No. 94745

the strongest wall lining in use. It will materially strengthen and stiffen a frame house, as compared with lath and plaster or other wall covering. Other wall boards are often wrongly called Compo-Board, and sold as such. Be sure you buy and use *real* Compo-Board—our trademark, as shown above, is on every piece. It's sold almost everywhere.

Northwestern Compo-Board Company
5777 Lyndale Ave.
Minneapolis, Minn.

You will get **SPECIAL ATTENTION** if you tell Advertisers you read American Carpenter and Builder.



Octagon Tile



Excelsior Tile



Diamond Tile



Walter's Shingles



Corinthian Tile



Spanish Tile

The Square Deal

dominates all our business doings. Our sales agents are protected in their territory. No matter how the business originates, the sales must come through our representative in that territory. All inquiries are passed to him for action. We never play one dealer against another; while we want business, we don't want it through dubious and unfair methods. Sales must come through our agents.

Walter's and Cooper's Metal Shingles

The handling of these shingles has always paid the handler well. Your town is ripe for the picking. Get the territory and get to work; make some money in nineteen fourteen.

The finest line of Metal Shingles made. In seven handsome designs and made in galvanized and painted tin and in copper. Samples if you desire.

Sales must come through You

W. & C. Metal Shingles are best, deliberately intended to be, and have been for over thirty years. There is no other roofing material, of this or any other kind, that will stand in comparison, and you're backed in your sales by a concern that will give you a square deal all the time.

Ask for the Selling Proposition.

A Handsome Catalog is sent to anyone interested. Ask for Catalog A.-C.

National Sheet Metal Roofing Co.
339-88 Grand Street, Jersey City, N. J.

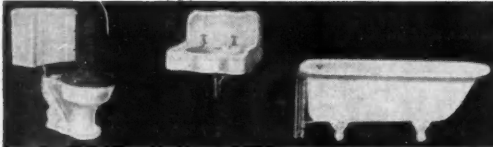

SEND TODAY FOR COMPLETE CATALOGUE "41"
EVERY ARTICLE GUARANTEED

EVERYTHING IN GUARANTEED PLUMBING & HEATING SUPPLIES

BUY AT WHOLESALE PRICES. Bathroom Outfits, Sinks, Pipe, Fittings, Valves, Faucets, Heating Boilers, Radiators, Water Pressure Systems and Lighting Plants for Country Homes, etc., etc.

Our \$200,000.00 plant behind our GUARANTEE.

JOHN HARDIN COMPANY

30 Years at 4543-53 Cottage Grove Ave., CHICAGO

GENUINE BANGOR

Roofing Slate
Structural Slate
Blackboards

Large Facilities, Prompt Deliveries

EAST BANGOR CONSOLIDATED SLATE CO.

East Bangor, Pa.



OAK FLOORING

"AMERICA'S BEST FLOORING"

Builders and owners will find it a clinching argument to say "It's floored with OAK FLOORING." It is the biggest single feature to look for in any house or apartment building. It imparts an air of refinement and elegance. It is the modern flooring.

OAK FLOORING 3/4 inch thickness by 1 1/4 inch or 2 inch faces can be laid over old floors in old homes or over cheap sub-floors at a very low cost. It is cheaper than carpet or pine flooring. When laid it has all the appearance of heavy flooring.

There is a solid satisfaction and lasting pleasure in the substantial and dignified appearance of OAK FLOORING.

Contractors and carpenters find it very profitable to lay 3/4 inch stock over old floors in old homes during dull periods. A little canvassing is all that is necessary to secure jobs. A carpenter or handy man can lay OAK FLOORING successfully.

For durability, OAK is the best. OAK FLOORING laid thirty years ago, after very hard use, is still in good condition.

Write for Booklet

THE OAK FLOORING BUREAU, 890 Hammond Bldg., DETROIT, MICH.

You will get SPECIAL ATTENTION if you tell Advertisers you read American Carpenter and Builder.

A REAL HOME



The sentiment of home life can be shown in the design and plan, but it requires study, time, and the true designer's ability to secure these desirable and necessary features.

You busy contractors haven't a great deal of time to give and it's right here you will find

KEITH'S MAGAZINE on Home Building

an inspiration and side partner. "How to build Real Homes," is our life study, and is presented to you thru attractive illustration and practical design; thru instructive articles by the brightest of writers on the subject of home building. Each 80-page monthly number of Keith's Magazine will prove a welcome visitor. Shall we enter your subscription for the coming year under our Special Limited

Offer to Builders

To each contractor sending me a year's subscription with Two Dollars (Sub. price alone) I will mail free, postpaid, your choice of

Any Two Plan Books

- | | |
|-----------------------------------|-----------------------------------|
| 136 Designs for Bungalows. | 172 Designs costing above \$4000. |
| 138 Designs for Low Cost Homes. | 125 Designs costing above \$6000. |
| 125 Designs costing below \$4000. | 100 Designs Brick and Cement. |
| 175 Designs costing below \$5000. | 50 Designs Modern Garages. |
| 175 Designs costing below \$6000. | 40 Designs Duplexes and Flats. |

M. L. KEITH 625 McKnight Bldg.
Minneapolis, Minn.

Here's a mahogany finish that won't fade

You've long wished for a fadeless mahogany finish. You can get it if you specify a coat of Lowe Bros. Non-fading Dark Mahogany Oil Stain, then one of

Lowe Brothers

Mahogany Glaze

—and a finishing coat of Lowe Bros. Inside Rubbing Varnish. The result is a full, rich color and beauty resembling solid mahogany—and it *won't fade*. Contractors who specify Lowe Bros. products insure good results for their customers and a good reputation for themselves.

FREE: Specification Book

Gives you the essential facts for preparing clear and definite specifications on varnish and paint—tells how to select the proper materials and use them to best advantage. Write for this book today.

The Lowe Brothers Company

457 E. Third St., Dayton, Ohio

Boston Jersey City Chicago Kansas City
Minneapolis

LOWE BROS., Ltd., Toronto, Canada

A Square Deal



Be the Man Who GIVES Orders

is all you want. Just a chance to show what stuff you are made of. But, remember—there is one thing that counts—TRAINING.

Get the RIGHT training right. If you've never had the advantage of a first-class knowledge of building,

plans, specifications, estimating, contracting, etc., then here's your chance. Our "Chicago Tech." Day and Evening Schools have hundreds of carpenters, builders and men of the building trades who are studying under the expert teaching of Chicago's leading architects, estimators and contractors. If you cannot attend these Day and Evening Classes, you can study the same work at home by the "Chicago Tech." method. Our new, quick, easy plan to qualify you in a short time by home study.



Better things are in sight.

Mark and Mail this Coupon NOW!

WE FURNISH
FREE
A COMPLETE
\$15.00
DRAWING
OUTFIT

Mark "X" opposite work in which you are interested. Without obligation on you we will send full information free.

- | | |
|---|--|
| <input type="checkbox"/> Architectural Drafting | <input type="checkbox"/> Building Superintendence |
| <input type="checkbox"/> Builders' Course | <input type="checkbox"/> Structural Steel Drafting |
| <input type="checkbox"/> Estimating | <input type="checkbox"/> Structural Steel Design |
| <input type="checkbox"/> Plan Reading | <input type="checkbox"/> Reinforced Concrete |
| <input type="checkbox"/> House Planning | <input type="checkbox"/> Machine Drafting |
| <input type="checkbox"/> General Contracting | <input type="checkbox"/> Machine Design |

1017

Name.....

Address.....

Town..... State.....

College or Home-Study Course

ALL BLUE
PRINT PLANS
FREE
WITH
THIS
COURSE

Chicago Technical College

1017 LAKE VIEW BUILDING, CHICAGO, ILLINOIS

You will get SPECIAL ATTENTION if you tell Advertisers you read American Carpenter and Builder.

TIN PLATE CHARCOAL IRON TERNES

METAL SHINGLES

CORRUGATED SHEETS

ROLL ROOFING

"CANTON"

Improved Steel Ceilings
Skylights

Special Sheet Metal
Work of all kinds.
Large stocks car-
ried at factory and
our branch houses.
Get our prices.
Write for catalogs.



New York Branch and
Warehouse:

The Canton Steel Ceiling Co.
221 11th Avenue

Minneapolis Branch and
Warehouse

The Canton Steel Ceiling Co.
206 South 3rd Street

GALVANIZED SHEETS BLACK SHEETS

VENTILATORS

EAVES TROUGH

CONDUCTOR PIPE

A-A-A-Asphalt
Cement.
B-B-B-Fiber
Board.

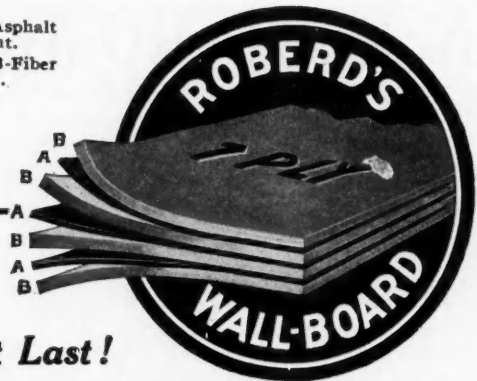

At Last!

Seven-Ply Wall Board

At last you can have a perfect wall board, stiffer, harder, tougher, more easily handled, more quickly applied and more satisfactory when on the walls. We have solved the problem. We are now making

Roberds Ideal Wall Board

with *four* layers of fiber board and *three* layers of asphalt adhesive compound. Our discoveries, our special machinery, our secret methods of manufacture and our original asphalt cement make possible the production of this IDEAL WALL BOARD.

Dealers everywhere are enthusiastic about it. Contractors prefer it to all other brands. Home owners delighted with the fine finish and the perfect butting of edges which enables them to paper direct to the wall board.

We have doubled the capacity of our plant to take care of the increasing demand for Roberds Ideal. No advance in prices. Special inducements to the trade. Write today for our dealers' proposition.

The Roberds Manufacturing Co.

100 Railroad Street

Marion, Indiana

For Permanence



DUCTILE
DURABLE
DEPENDABLE

Black and Galvanized Sheets
and Formed Products.

The Sheet Metal of Quality

Made by

The Stark Rolling Mill Co.
Canton, Ohio

For Sale by Jobbers Everywhere
General Distributors for the
Dominion of Canada

THE PEDLAR PEOPLE LIMITED

Oshawa

Toronto

Montreal

Winnipeg

You will get SPECIAL ATTENTION if you tell Advertisers you read American Carpenter and Builder.

FOR 30 DAYS ONLY

we will make a special price reduction on any ceiling made up from the plates shown here. It means a big saving for you.

KLAUER METAL CEILINGS

and Side Walls are primed with one coat of light gray paint on both sides. Wood brackets for cornice and cone head nails furnished without extra charge. With every shipment we send blue print showing exact size and arrangement of each member of the design. Stamped buttons for nail holes save 25% on the cost of erection and prevent mistakes in matching.

TAKE ADVANTAGE OF BIG DISCOUNT

by placing your order now. There's a Klawer Ceiling for every one of your buildings. We'll furnish estimates free of cost. Write us for particulars and our handsome catalog. Look it over before your busy season starts.

Klawer Manufacturing Co.
DUBUQUE Dept. 9 IOWA

SEND FOR FINE FREE CATALOG

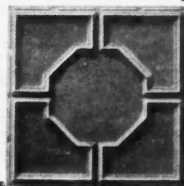
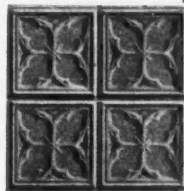
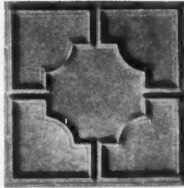
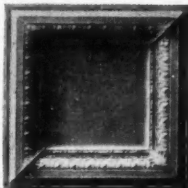

What is Your Reputation Worth?

An immensely wealthy corporation recently estimated the value of its reputation as 56% of its total assets—which meant millions.

Doesn't this suggest increasing the value of your reputation in your community? By all means, then, handle the Metal Ceilings of Quality—always stamped "BROOKLYN." Made of superior material and artistically designed.

Write us and we will show you how to increase the value of your reputation 56%.

BROOKLYN METAL CEILING CO.

283 Greene Avenue

BROOKLYN, N. Y.



THE IVES PATENT WINDOW STOP ADJUSTER

Prevents dust, drafts

and window rattling

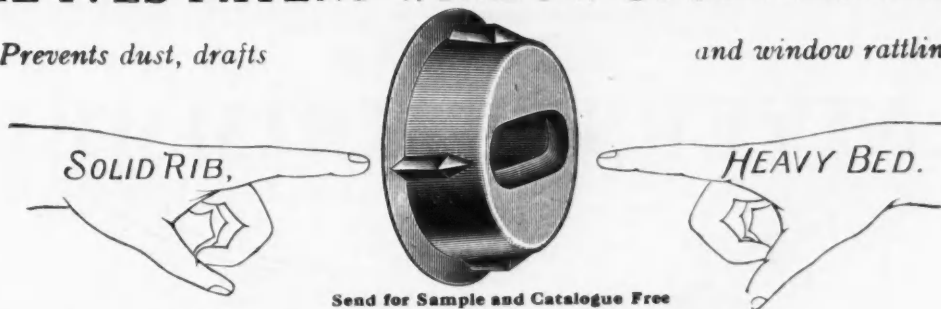

Send for Sample and Catalogue Free

1 piece of metal, will not cup, bend or turn in tightening screw.

THE H. B. IVES CO., Sole Mfrs. New Haven, Conn. U. S. A.



SAVE TIME and MONEY

make a neat, attractive, weather-proof corner job by using

KEES METAL BUILDING CORNERS

made of galvanized iron. Hold paint like wood. Save cutting bevels. Write today for free samples and pictures of houses finished this way.

F. D. KEES MFG. CO. BOX 552
BEATRICE, NEBR.

If you have never used Gossett Storm Sash Hangers, ask for samples.

METAL CEILING

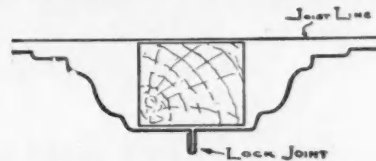

See that Joint?

The Acme of perfect construction. Don't nail or slip the joints. Lock them. Full information in catalogue E.

S. KEIGHLEY METAL CEILING & MFG. CO.
PITTSBURGH, PA.

You will get SPECIAL ATTENTION if you tell Advertisers you read American Carpenter and Builder.

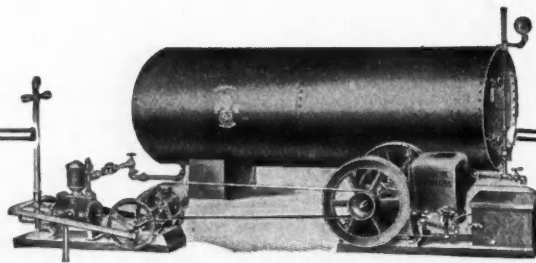

The Convenience of a Private Water Supply

in the home more than pays for installing a system that is thoroughly modern. The outfit, shown above, comprising motor or engine, pump and tank can be set up in the basement. The service it furnishes is equal, and in many respects superior to that furnished by city mains.

Fairbanks-Morse Pneumatic Tank Systems

sell at an extremely reasonable price, cost very little to operate, and are so simple as to require hardly any attention. From the many sizes every requirement can be filled.

Complete installation diagrams are furnished with every outfit.

Write for Catalog
No. 2H 1409

Fairbanks, Morse & Co.

900 S. Wabash Ave., CHICAGO 30 Church St., NEW YORK CITY
158-162 First St., SAN FRANCISCO

EBEL HOISTING ENGINE

Built in three sizes—3 to 12 H. P. Can be had for belt drive or direct connected as desired.

The solid construction, weight and price make this the ideal machine for meeting all requirements of building construction. You can make no mistake by getting our circulars and looking the machine over. An EBEL is a good investment.

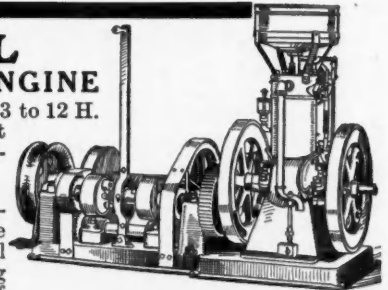

WRITE US TODAY

LANSING MOTOR & PUMP CO. LANSING, MICH.

Use KEROSENE Engine Free!

Amazing "DETROIT" Kerosene Engine shipped on 15 days' FREE Trial, proves kerosene cheapest, safest, most powerful fuel. If satisfied, pay lowest price ever given on reliable farm engine; if not, pay nothing. No waste, no evaporation, no explosion from coal oil.

Gasoline Going Up!

Gasoline is 9c to 15c higher than coal oil. Still going up. Two pints of coal oil do work of three pints gasoline.

Amazing "DETROIT"

—only engine running on coal oil successfully: uses alcohol, gasoline and benzine, too. Starts without cranking. Only three moving parts—no cams—no sprockets—no gears—no valves—the utmost in simplicity, power and strength. Mounted on skids. All sizes, 2 to 20 h. p., in stock ready to ship. Engine tested before crating. Comes all ready to run. Pumps, saws, threshes, churns, separates milk, grinds feed, shells corn, runs home electric light plant. Price (stripped), \$29.50 up. Sent any place on 15 days' Free Trial. Don't buy an engine till you investigate money-saving, power-saving "DETROIT." Thousands in use. Costs only a postal to find out. If you are first in your neighborhood to write, you get Special Extra-Low Introductory price. Write! (128)

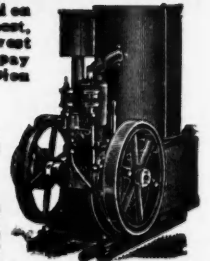

Detroit Engine Works, 495 Bellevue Ave., Detroit, Mich.

FOX

"UNIVERSAL TRIMMER"

TRADE MARK

A
Machine
For
Every
Need

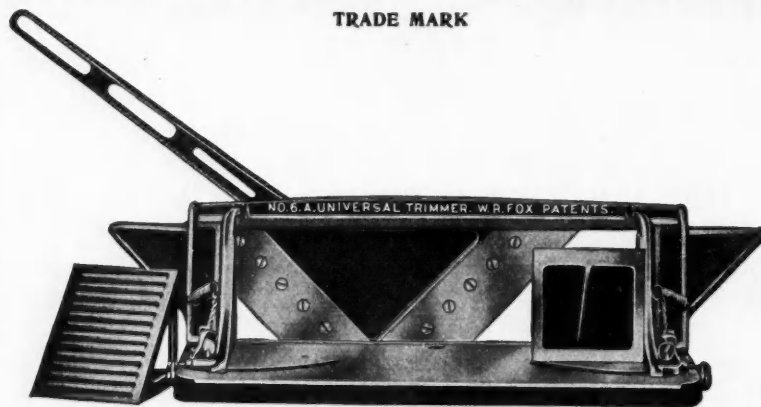

6A. FOX "UNIVERSAL TRIMMER"

A
Need
For
Every
Machine

You Will Never Know What Perfect Work is Until You Use a Fox "Universal"

One Stroke of the Knife Produces a Perfect Angle—
This Means a Great Saving of Time to You.

Write TODAY for Our New Catalog

FOX Machine Co.

22 FRONT AVENUE N. E.
GRAND RAPIDS, MICHIGAN

You will get SPECIAL ATTENTION if you tell Advertisers you read American Carpenter and Builder.

IF you could see stagnant air as distinctly as you can see stagnant water, with its scum and slime, you would readily understand why the Campbell way of heating houses is the best way to heat *yours*—no matter what the size.

Clean, Moist, NORMAL Air
Guaranteed to You with

CAMPBELL'S WINTER-CHASER

If installed under Campbell's specifications, this furnace is guaranteed to heat the house to a temperature of 70 degrees in the coldest and windiest weather.

You can have a surety company bond with millions behind it as a guarantee that the contract will be fulfilled.

Write for booklet, "Twice a Day" showing the Campbell record for fuel-economy, ease of handling and long service.

Campbell Heating Co.
1221 Walnut St.
DES MOINES, IA.

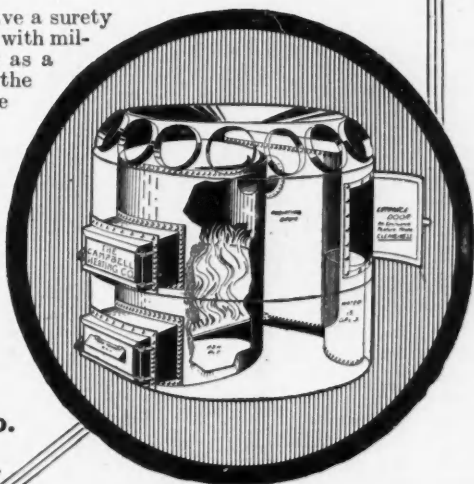

To Make YOU A Better Builder

If you are a carpenter—to make you a foreman.

If you are a foreman—to fit you to take contracts yourself and make the big money a good contractor makes.

If you are a contractor—to show you how to get *more* contracts by figuring *closer* and *more accurately*—or to become an architect and collect the big fees a good architect gets.

This is the purpose of the clear and practical Building and Architectural Courses of the International Correspondence Schools.

Every month over 400 men report advancement or increased earnings that have come as a *direct* result of this practical I.C.S. training. What the I.C.S. have done for these men, they can do for YOU.

Just indicate on the attached coupon the line of work about which you would like to know more. Mail the coupon to the I.C.S. and they will show you how you can get this information right in your *own home* during your *spare time*. **Mail the coupon NOW.**

International Correspondence Schools

Box 910, SCRANTON, PA.

Please explain, without further obligation on my part, how I can qualify for a larger salary and advancement to the position, trade, or profession before which I have marked X.

Architect Architect's Draftsman Building Foreman Building Contractor Building Inspector Estimating Clerk Structural Engineer Structural Draftsman Plumb. & Heat. Con. Supt. of Plumbing Foreman Steam Fitter	Plumbing Inspector Heating and Ventilation Civil Engineer Surveying Mining Engineering Mechanical Engineering Mechanical Draftsman Stationary Engineer Electrical Engineer Electric Lighting Electric Railways	Concrete Construction Automobile Running Foreman Machinist Sheet-Metal Pat. Drafts. Bookkeeper Stenographer Law for Contractors Advertising Man Window Trimming Civil Service Exams. Chemist
--	--	--

Name _____
 Street and No. _____
 City _____ State _____
 Present Occupation _____

The Bovee Furnaces

AT
Manufacturer's Prices



Will give every one of your patrons most perfect results. They last longer and actually require about one-half the fuel used by other furnaces.

They are made heavy, of the very best material and workmanship. Take your rule and measure the fire pots, the large combustion chamber and the long travel of heat and compare it with all other furnaces and see **WHY** the Bovee

uses less fuel and lasts longer than others. Get our special prices. We can save you 40% on a heating plant. Any handy man can install them.

Bovee Furnace Works

50 Eighth Street Waterloo, Iowa

You will get SPECIAL ATTENTION if you tell Advertisers you read American Carpenter and Builder.

ASHBY'S
Designs of Schools and Libraries
 display a composition of utility, durability and good, pure architecture without any "gingerbread."
 No buildings are too large or too small for our personal and prompt attention. We develop your own ideas into a practical set of plans and specifications which can be executed to the smallest details into a building that can be built within your means and to your entire satisfaction.
 Ashby's "Designs of Schools and Libraries" will be sent to parties interested in the erection of a school building or library for which plans have not yet been procured.

G. W. ASHBY—ARCHITECT
 11th Floor, Medinah Bldg.
 CHICAGO, ILL.

You will get SPECIAL ATTENTION if you tell Advertisers you read American Carpenter and Builder.



Something Worth Having

Cheap tools are for cheap men. We are not interested in cheap men nor you in cheap tools—it pays to get the best in each case.

This is a roll to be proud of, and every chisel will prove a friend—one you can depend on.

White's tools have been known as the very best for the last 77 years. Ask your dealer. If he won't write for prices for you, or doesn't have our tools, drop us a card.

The L. & I. J. WHITE CO.
No. 10 Columbia Street BUFFALO, N. Y.

Each Roll Contains Six Chisels and one Screw Driver.

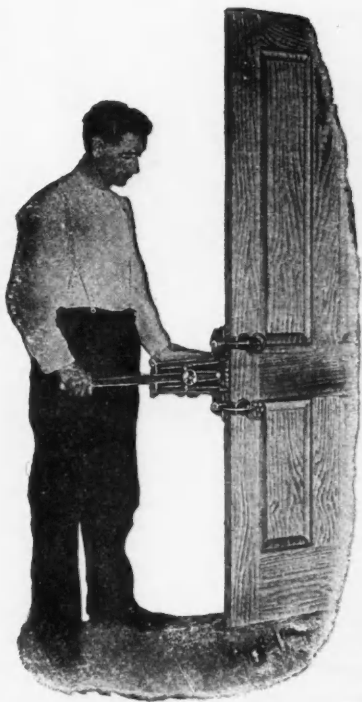

Time is the Test

The MILLER DOOR MORTISER has stood the test of time. Where other mortisers have failed the MILLER has stood up under the hardest kind of work.

There has never been anything to compare with the MILLER Door Mortiser—for it is made on the right principle and of first-class material, by first-class workmanship.

Will Cut an Opening for a Mortise Lock in 2 Minutes

with little labor and will make a perfectly true job. It makes no difference what thickness the doors are, and whether hard or soft wood, for the MILLER works true on them all.

Complete with five cutters, covering locks from one-half inch to one and one-eighth inches thick.

Sent subject to trial. Thousands now being used by carpenters and contractors everywhere. Additional particulars sent upon request—write for them.

A. W. Miller Manufacturing Co.
Riverside, Calif. Cincinnati, Ohio
Our Butt Mortiser and Rule Gauge, 75 cents Postpaid

You will get SPECIAL ATTENTION if you tell Advertisers you read American Carpenter and Builder.

PRICE REDUCTIONS on Furnaces and Fittings are Now in Order

It is our practice during the dull season, which begins January 1st, to make a material reduction in our charge for hot-air furnace equipments, and all purchases made for shipment between January 1st and May 1st are billed at the reduced prices. If, therefore, you can make it convenient to order within that time, you will secure the very lowest price it is possible to make on furnace heating equipments. The quality is unchanged; we make but one quality and that is the *best*.

Remember, we sell our furnaces and equipment *direct from factory to consumer* and we give you factory prices. We assume responsibility for the success of the equipment, and we will give you two months' cold weather trial, now or next winter, before we are paid, and if you are not satisfied, the outfit may be returned at our expense for freight both ways, and you pay us nothing.

Such an offer means that our goods will please you, for if they would not we could not offer to sell, year after year, on such terms.

Send us a sketch of your house and let us tell you just what we can do. This will cost you nothing and will put you in the way of saving money and securing comfort for years to come.

Hess Warming & Ventilating Company 1220 Tacoma Building, Chicago

If you are a builder and contractor, let us know, for we have a profit-sharing arrangement which we make with builders, and it would pay you to ask us about it.

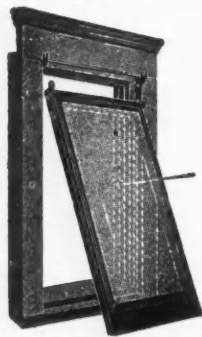

Use these E. Z. Way Hangers in putting up screens, storm sash and basement windows. They are time savers and all owners want them on their buildings. Kindly note the E. Z. Way Hangers can be applied from the inside of the house, which is an advantage that no other hanger in the market has. We are also large manufacturers of Screen Mouldings and "Clincher" Felt Weather Strip. Be sure and specify the DENNIS quality if you want the kind that is **MADE RIGHT.**

Manufactured only by

W. J. Dennis & Co. - 2226 W. Lake St., Chicago
Free Sample to any address for your Hardware dealers' name

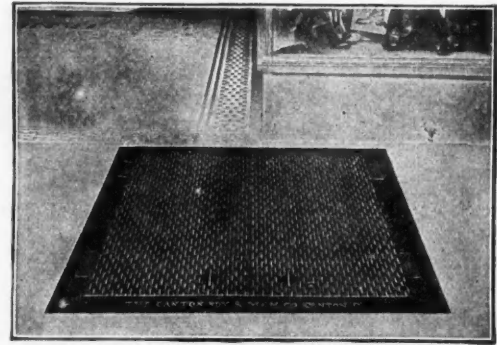

Canton

- SIDE WALK DOORS -

lead in safety, workmanship, neatness of design and quality of material.

They are made of wrought steel and iron and are firm under the tread. Lie flush with sidewalk. No protruding hinges or anything to trip passersby. Made with "anti-slip" top. Lock from outside or inside as ordered; burglar-proof; thoroughly drained; stay rods and chains guard opening when doors are raised.

Send for FREE CATALOG—B-1 of Coal Chutes, Area Gratings, House Movers Jacks, Cast Iron Columns and many other items of interest to builders.

Canton Foundry & Machine Co.

Canton, Ohio

Berger's Rib-Trus Reinforcing and Furring Plate

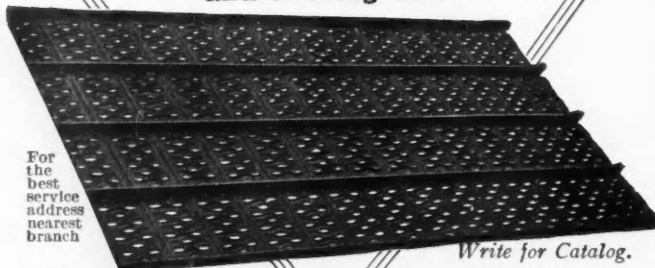

For the best service address nearest branch

Write for Catalog.

The Berger Mfg. Co., Canton, Ohio

New York Boston Minneapolis St. Louis San Francisco Philadelphia

You will get **SPECIAL ATTENTION** if you tell Advertisers you read *American Carpenter and Builder*.



A WHITE TRUCK

Is Your Best Advertisement

YOUR ownership of a White guarantees to your customers the most prompt and efficient delivery system money can buy. A White Truck will cost you a little more to begin with, because it is built a little better, but it will cost so much less to operate and maintain that it is by far the best investment in the end. Always ready to run, good twenty-four hours of the day in all seasons, in a White Truck the dependability of your service to your customers is always assured.

What Lumber Companies Say

"We are satisfied with the White Truck because it has given us good results considering the hills we must climb with it. We have been able to take orders from people living in other towns which we could not do before we had the truck."

Clark Brothers & Company
Plymouth, Pa.

"We purchased a three-ton White Truck from you on Nov. 13, 1912, which has been in continual service since, and up to this writing have had no expense for repairs connected therewith, and is giving entire satisfaction."

West Lumber and Manufacturing Co.
Plymouth, Pa.

THE WHITE  COMPANY

Manufacturers of Gasoline Motor Cars, Trucks and Taxicabs

CLEVELAND

You will get **SPECIAL ATTENTION** if you tell Advertisers you read American Carpenter and Builder.

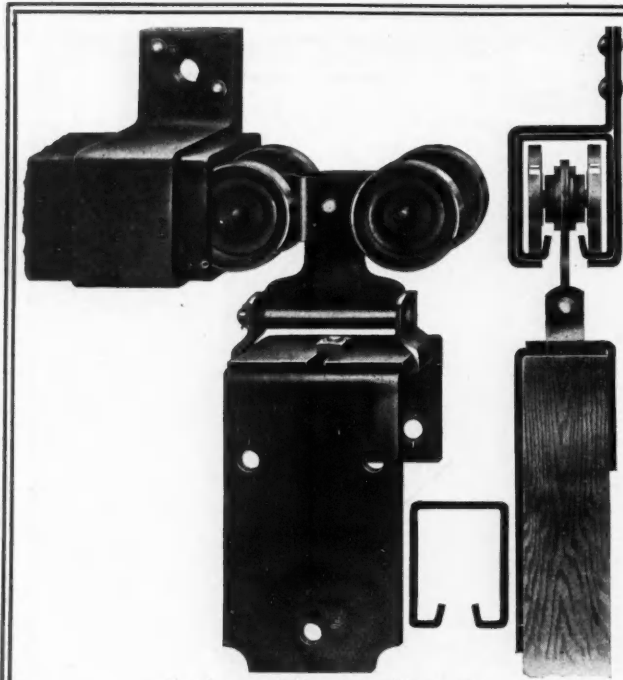

For doors weighing up to 400 pounds.

Hinged pendant extra strong and permits door to swing out at bottom if desired. Suitable for doors 1½ to 2 inches thick. Track can be attached to side or ceiling supports, and is furnished in any length up to ten feet in one piece. Brackets for side wall attachment furnished regularly. Runs in No. 31 16-gauge trolley track. Distance from top of door to center of hole in bracket 5½ inches. A pair of hangers consists of two hangers and carriers, one center and two end brackets, lag bolts for brackets and carriage bolts for hangers. Weight—Hangers, per pair, 10 pounds; track, per foot, 1½ pounds.

Delivering the Goods

No man or firm ever achieved lasting success by any other method than that of DELIVERING THE GOODS. And Richards-Wilcox success is built on that solid foundation.

We make "A Hanger For Any Door That Slides." That refers not only to the kind of door, but also to the price the owner is willing to pay for its sliding.

The hanger here illustrated is our No. 321 and insures to an absolute certainty permanently satisfactory sliding barn doors.

Your hardware dealer can give you price particulars and take care of your orders for it.

Richard's-Wilcox
 MANUFACTURING CO.
 AURORA, ILL. U.S.A.

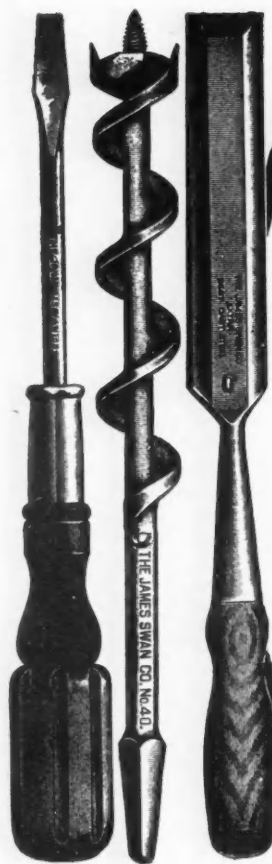

When you want tools of any kind — tools that you can bank on to be just the kind and quality you want them to be, insist on the Swan Trade Mark.



It's a plain guide to all that is best in carpenters' tools and your assurance that you are dealing with an old, reliable firm that makes tools as good and solid as its reputation.

ASK FOR CATALOG
 The
JAMES SWAN CO.
 Seymour,
 Conn.



Hammer Insurance

SPECIAL

Our "VANDOR VANADIUM" Nail Hammers in two sizes. No. 22, 13 oz. Finishing; No. 21, 16 oz. Standard. We will send either size Parcel Post for your Dealer's name and \$1. This Hammer we insure for life. Made for hard work and lots of it. You can return it any time if it proves defective and get a new one.

This hammer is warranted to draw anything from a headless brad to a spike. Drop Forged from the toughest Vanadium Steel. Second growth hand shaved Hickory Handle. Tempered in oil. Easy to work with. Get one to-day. Remember only \$1 and your dealer's name for either size, 13 oz. or 16 oz. Mail your order NOW.

Van Doren Manfg. Co., Inc. Chicago Heights, ILL.
 (Vanadium Dept.)



This Pearson's Automatic SHINGLE NAILER WILL PAY FOR ITSELF ON FIRST JOB

Do your nailing fast—faster than ever before. You can use this Pearson's Nailer on any pitch roof. Wear mittens, gloves, etc. This "Hand Nailer" is the only Nailer—throw nails in by the handful—then start nailing. Nails easily driven through tin or quite heavy sheet iron.

These nailers are made in two sizes—The BLUE Nailer for 3d common No. 14 gauge wire nails. The RED Nailer for 3d galvanized No. 13 gauge 1¼ inch wire nails.

It will come right to your door, quick, by insured parcel post, all prepaid for only \$5.00.

IT MAKES GOOD.

PEARSON MFG. CO. - ROBBINSDALE, MINN.

You will get SPECIAL ATTENTION if you tell Advertisers you read American Carpenter and Builder.

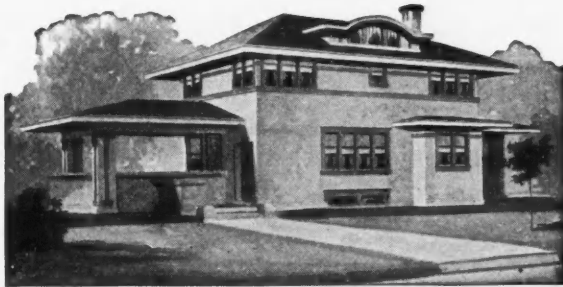

Cement Houses and How to Build Them

This large book of 176 (8 x 11 inch) pages contains illustrated details of cement construction—standard specifications for cement—concrete blocks—general information concerning waterproofing, coloring, aggregates, mixtures, paving, reinforcing, foundations, walls, steps, chimneys, floors, etc., together with perspective views and floor plans of 87 stucco and concrete block houses.

The illustrations show the houses exactly as they will look when built. All the floor plans are shown, giving the location and dimensions of all rooms, closets, porches, etc.

This Book Sent Free

Send in your subscription today and receive one of these books by return mail, **Free**, postage paid. Regular subscription \$2.00 per year.

American Carpenter and Builder
1827 Prairie Ave. CHICAGO, ILLINOIS



Brick Houses AND HOW TO BUILD THEM

Containing 219 (8 x 11 inch) pages illustrated by over 300 designs and details of brick house construction, beside perspective views and floor plans of 82 brick houses with estimates of cost construction and miscellaneous data about the use of brick from its manufacture to its placing in the building, including ornamental brick and tile work, sewer construction, fireplaces, brick veneer construction, arches, cements and mortars, how to estimate the cost of brick construction, etc., etc. A valuable book for the home-builder as well as to the builder and brick-layer.

Your Copy is Ready to Mail

Simply send us your subscription at the regular rates and this book will be sent by return mail, **Free**, postage paid. Regular subscription \$2.00 per year.

American Carpenter and Builder
178 W. Jackson Blvd. CHICAGO, ILLINOIS



Style 125

All Sizes

WILLIS VENTILATORS

have no equal for securing a free, outward air current and preventing down drafts. There is a **WILLIS** for any and every building where ventilation should be provided. The honest, thorough construction of Willis Ventilators and the moderate price recommend them to your attention.

You Builders who put up barns, school houses, churches and such buildings, know how important ventilation is. Plan your buildings for ventilators and specify **WILLIS VENTILATORS** when you want to insure complete satisfaction.

Our line of **SHEET METAL GOODS** is so large and varied that you will find our big catalog a reliable, handy reference. Ask for it. It is free. We want you to know that we can supply whatever you need in the way of Ventilators, Skylights, Store Fronts, Mouldings, Finials, Metal Lath, Coal Chutes, Metal Ceilings, Fire Doors, etc., in the highest grade goods at very moderate prices. We guarantee prompt attention to orders and quick shipment.

ASK FOR OUR BIG CATALOG.

WILLIS MANUFACTURING CO.
Manufacturers of
Architectural Sheet Metal Goods
GALESBURG ILLINOIS



Style 125G

All Sizes

You will get **SPECIAL ATTENTION** if you tell Advertisers you read American Carpenter and Builder.



Copyrighted by the L. Wolff Mfg. Co.

Silentflow

A Noiseless Water Closet

In the toilet adjoining the sick room one of the distressing noises can be eliminated by installing the "Silentflow."

This closet was not put on the market until it was proven perfect in construction, design and workmanship.

SPECIFY WOLFF H-7005 FOR RESIDENTIAL USE

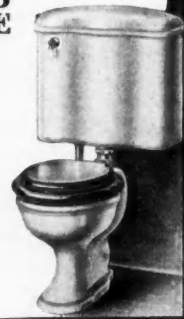

L. WOLFF MANUFACTURING COMPANY

Manufacturers of

Everything in the Plumbing Line

The only complete line made by any one firm.

General Offices, 601-627 W. Lake St. Showrooms: 111 No. Dearborn St., CHICAGO
Pottery: Trenton, N. J.

BRANCHES: Denver, Colo.; Omaha, Neb.; Minneapolis, Minn.; Dallas, Tex.; Rochester, N. Y.;
St. Louis, Mo.; Washington, D. C.; Cleveland, O.; Cincinnati, O.; Kansas City, Mo.;
San Francisco, Cal.

PLUMBING AND HEATING SUPPLIES AT WHOLESALE

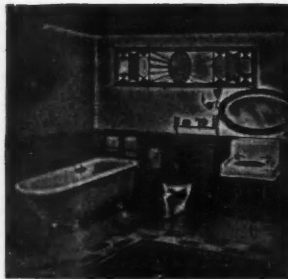

When in the market for Plumbing and Heating Supplies and you wish to

SAVE 20 to 40 Per Cent

on every article, write for my free illustrated Catalog. The only house that sells first class guaranteed goods at wholesale prices direct. Shipments are promptly made from a very complete stock. Small orders are as carefully handled as large ones.

B. B. KAROL, 768-772 W. Harrison St., Chicago, Ill.



A HOT AIR FURNACE

For Less Than \$50 Complete

For 5 and 8 Room Dwellings

An Unheard of Price and a most Remarkable and Indestructible Furnace

No Pipes No Lost Heat

AMERICAN BELL AND FOUNDRY CO.

NORTHVILLE - MICH.

HESS MEDICINE SANITARY CABINET LOCKER



The Recessed steel Medicine Cabinet

The Only Modern, Sanitary STEEL Medicine Cabinet

or locker, finished in snow-white, baked everlasting enamel, inside and out. Beautiful beveled mirror door. Nickel plate brass trimmings. Steel or glass shelves.

Costs Less Than Wood

Never warps, shrinks nor swells. Dust and vermin proof, easily cleaned. Should be in Every Bath Room. Four styles—four sizes. To recess in wall or to hang outside. Send for illustrated circular.

HESS, 920L Tacoma Bldg., CHICAGO

Makers of Steel Furnaces

Free Booklet

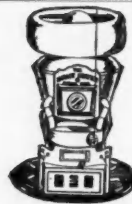

Write at Once for the Jahant Specification Hand Book—It's Free

This book tells you what you ought to know about proper heating and ventilation, and tells why you ought to specify the Jahant Down-Draft Furnace.

It tells how to estimate on the cost of proper heating equipment; how to reduce your bids and at the same time turn out a better job with a better profit for yourself.

It explains the construction and operation of the Jahant and how it delivers plenty of heat wherever and whenever heat is needed at a saving of one-third to one-half in fuel bills.

It tells how we back your recommendation of the Jahant Furnace with a legal binding 360 Day Guaranty Bond—and it contains a lot of other information which you cannot afford to be without. Write for the book today.

THE JAHANT HEATING CO. 164 Mill St., Akron, Ohio
Furnace Builders for more than 30 years.

SPECIFY THE JAHANT DOWN DRAFT FURNACE

You will get SPECIAL ATTENTION if you tell Advertisers you read American Carpenter and Builder.

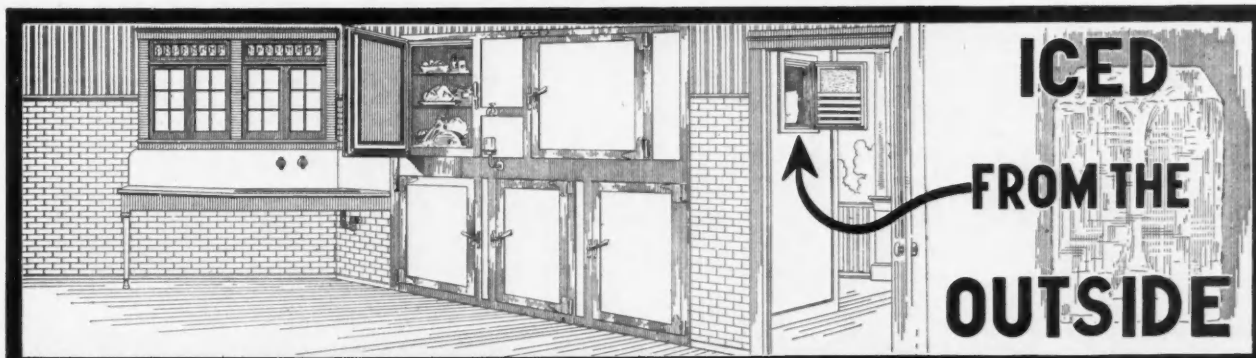

Plan the Refrigerator as an Integral Part of the House!

When designing homes of the better class, let the problem of a refrigerator be put up to us. We guarantee to satisfy you and delight your client. Send us the floor plan and we will suggest ideas to embody in the building a

McCray "Built in" Refrigerator

Note the picture above. This shows a McCray "built in" Refrigerator being iced from the outside. The ice chamber has two doors. One opens up on the porch for outside icing. The other door opens with access from the kitchen. This

keeps the ice man from tramping through the kitchen. Then in cold weather one can dispense with ice as the refrigerator is sufficiently cooled by leaving the outside door slightly open.

Expert Service Free to Architects and Contractors

Our expert draughtsmen are at your service gratis, to help you in the preparation of plans for refrigerators, cooling rooms and refrigerating systems in all kinds of structures.

Look Over These Catalogs

We will send any one or all on request.

No. 91—Regular Sizes for Residences.

No. AH—Special "Built-In" Refrigerators (as picture).

No. 73—For Florists.

No. 50—Hotels, Restaurants, Clubs, and Public Institutions.

No. 63—For Grocers.

No. 60—For Meat Markets.

Put them in your files for ready reference.

McCray Refrigerator Co., 606 Lake St., Kendallville, Ind.
Chicago 158—N. Wabash Ave. Branches in All Principal Cities. New York—McCray Bldg., 7-9 W. 30th St.

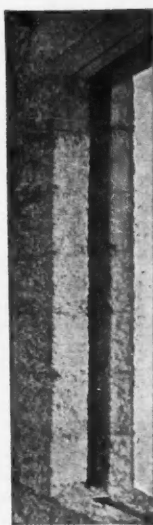

Why Duplicate Labor?

The Van Guilder Hollow Wall Machines erect the walls with the labor others employ to manufacture the building units, such as brick, tile, blocks, etc.

OUR CATALOG illustrates residences, schools, factories, etc., in all parts of the United States and Canada, with letters from the Builders and Owners.

By means of a recent discovery our Hollow Concrete Walls can now be erected in freezing weather, at only a moderate increase in cost and in absolute safety.

This discovery is explained and full details of our system of construction given in our 64-page book entitled "How to build with Van Guilder Hollow Wall Machines". Book and catalogue sent free at your request.

The Van Guilder Hollow Wall Co.
720 Chamber of Commerce Bldg.
ROCHESTER, N. Y.

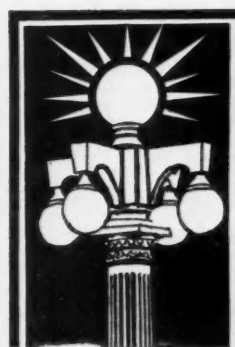

These reinforced concrete standards are handsome, durable, artistic and inexpensive. They do not rust like cast iron, become dented like sheet metal, or rot like wood. They require neither painting nor repairs, and are not affected by weather conditions.

CONCRETE LIGHTING STANDARDS

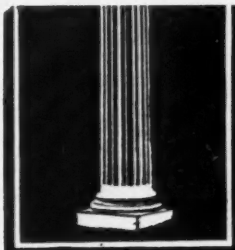

We have numerous beautiful designs, and make the standards of different kinds of concrete. Our sparkling granite concrete rivals natural granite in its beauty.

Write for booklet on "Ornamental Illumination." FREE.

THE PETTYJOHN COMPANY
534 No. Sixth Street TERRE HAUTE, IND.

SPECIFY AND USE SYKES METAL LATH

*Provide the Best
at a low price*

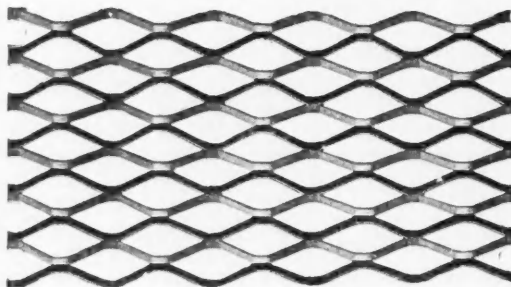

SYKES EXPANDED CUP LATH

is self-furring; can be fastened directly to the sheathing or studding; keys perfectly. When this lath is imbedded in the plaster, it makes a strong, reinforced wall. The strands are wider and stronger than in the ordinary lath. Weighs more to the square yard than any lath of the same gauge. Furnished with Anti-Rust (oil) coating, painted black or galvanized. Sheets 18x96 inches. 20 square yards to the bundle. Gauges 27, 26, 25 and 24.

**Sykes
Metal Lath**

present opportunities for the builder to decrease the cost of construction. This lath furnishes a strong, rigid base for all stucco and plaster work. The use of Sykes Metal Lath is recommended where a first-class material is desired but where the cost must not be great.

We would like to send you samples of the two kinds of lath shown here. Our circulars describe them fully. Send us your name and address.

Sykes Metal Lath & Roofing Co.
NILES, OHIO

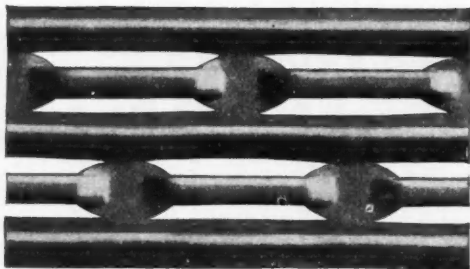

SYKES TROUGH SHEET LATH

The unusual design, strength and keying principle of this lath makes it desirable for use on any kind of a building. Perfect for inside plaster work. Easy to apply; easy to plaster on, and saving in material. Size of sheets: 13½, 15½, 18½, 23½ in. wide by 86 in. long.

THERE IS NONE BETTER

SYKES METAL LATH FOR ALL BUILDINGS

SYKES METAL LATH ALWAYS DEPENDABLE

**GRIMM'S
GALVANIZED CORRUGATED
WIRE LATHING**

"Patent Applied for"

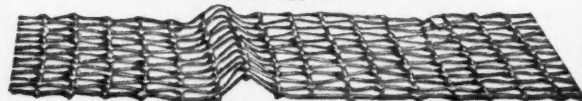

IT'S ALL IN THE V

THIS V-shaped corrugation eliminates furring, keeps plaster clear of wall, thereby securing air space and dry atmosphere. Gives necessary STIFFNESS without added weight, such as is necessary in most forms of stiffened Wire Lathing in which rods or small angles are woven into the fabric for stiffening purposes.

Plaster keys so firmly that it WILL NOT CRACK or drop off. This lathing is absolutely NON-CORROSIVE and WILL NOT RUST as it is galvanized after woven, which solders each joint and covers the entire surface of the wire with spelter (zinc) and COSTS 50% LESS to install than ordinary lathing. It will be to your interest to send for our Booklet No. 6-A. B. on Wire Lathing if you contemplate building. A post card will bring it to you. SEND FOR IT NOW.

Full Size

Full Size

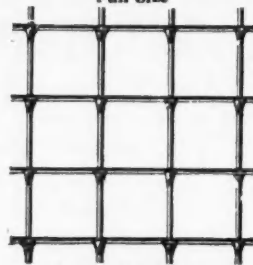

2 1/2 Mesh, No. 20 Wire

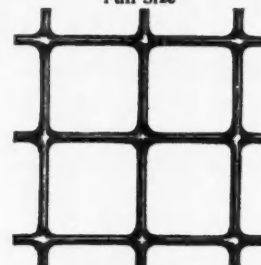

2 Mesh, No. 19 Wire

BUFFALO WIRE WORKS CO.

(Formerly Schoeler's Sons)

316 Terrace, BUFFALO, N. Y.

Send Us Your Plans for Estimates

—ORNAMENTAL IRON—

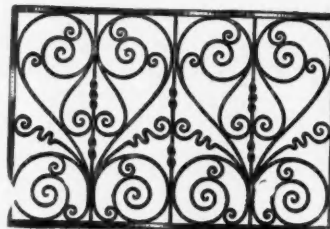

**Iron Stairs
Railings
Balconies
Elevator Enclosures
Fire Escapes
Side Walk Doors
Etc.**

OUR PRICES WILL
INTEREST YOU

THE MACK IRON & WIRE WKS. CO.
Sandusky, Ohio

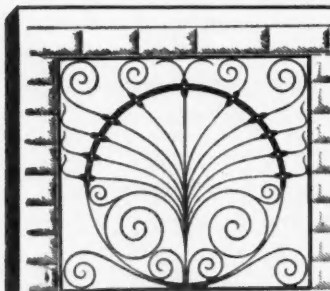

Mr. Builders — If you are lucky enough to read this advertisement, and wise enough to write and tell us what you buy in

**IRON, BRASS
and BRONZE**

we will send you catalog that is attractive enough

to go in any man's library. Do you want it?

DOW WIRE & IRON WORKS

Incorporated
Louisville, Kentucky

You will get SPECIAL ATTENTION if you tell Advertisers you read American Carpenter and Builder.

We Pay The Freight On These Houses

\$10,000 BOOK OF PLANS FREE

Design No. 73
Eight Rooms and bath, all rooms convenient and roomy. Size 28x24 feet.



Design No. 93
7 Rooms and bath, very attractive exterior; sleeping porch, balcony. Size 28x22 feet.



**Freight Prepaid
No Money Down**

Here is an opportunity for any man to own a home of his own, no matter how limited his means. Even if you have not definitely settled on any building plans, it will pay you big to take advantage of this sensational

\$890

\$899

offer. Order your material NOW and build later. We are determined that the Year of 1914 shall be the biggest, busiest season in the history of this company. Hence these unprecedented offerings, the like of which have never before been made in the history of building material business.

Think of the Enormous Saving Nowhere else, in all the

world, can you duplicate these prices. We will save you from 1/5 to 1/3 what you would have to pay elsewhere. Look well at the illustrations of the 4 homes here shown—note the brief descriptions. We will furnish you the material needed to construct any of these homes strictly according to our Plans, Specifications and Material list at the prices quoted for each. But that is not all. We will deliver all of this material right to your railroad shipping point, FREIGHT PREPAID BY US—no charge to be paid by you at all. You are not even required to pay one cent down. We ship subject to examination wholly at our own risk. We positively guarantee every item we send you to be high grade, clean, brand new stock. We would not dare ship from \$500 to \$1000 worth of material on these liberal, no-money-down, freight prepaid terms, were it otherwise.

Special Notice: These freight prepaid prices are for all points in Ill., Ind., Ohio, Southern part of Mich. and Wis. and Eastern part of Iowa and hold good for these 4 designs only. Special freight prepaid prices to any point outside of above territory.

These Prices Good Only For 30 Days

Please remember, the prices quoted in this advertisement hold good only for 30 days. After that they will positively be withdrawn. If you are wise you will not let this chance go by, as it may never come again. So be sure to write us today.

50c Buys Complete Set of Blue Print Plans This is the first time we have ever offered a complete set of plans for only 50c. Plans offered at this price are only for the designs shown in this advertisement. This is a part of the building material offer and like it, is good only for 30 days. Usually, when you go to an architect, plans like these would cost you about \$50. If you buy the bill of material from us we will absorb the 50c charge and the plans will cost you nothing.

\$10,000 Book of Plans Free!

The houses here shown are four of our regular designs taken from our wonderful Book of Plans, containing 100 pages of beautiful modern homes. Let us send you a copy of this magnificent Book FREE. Not only do we save you from 25% to 50% on your complete building, but we give you all the assistance you need for its proper and economical construction free of charge.

Plumbing Material

Write for prices on our complete bathroom outfits. We guarantee a saving of 30% to 50%.

Heating Plants

Steam, Hot Water and Warm air. Let us estimate on your requirements; big saving.

\$736

\$762

Our Guarantee Your Protection We guarantee all brand new stock, sufficient quantity, prompt shipment. Guarantee backed by \$10,000,000 capital.

CHICAGO HOUSEWRECKING CO.



Design No. 57
Six Rooms and bath. A Modern Home, Excellent Interior. Size, 24 ft. by 26 ft.



Design No. 60
Five Rooms, bath. Large Living room; Private Porches. Modern in every respect. Size 37x29 ft.

Harris Bros Co. 35th and IRON Sts. Chicago Dept BR-149



THE GALE

BARN AND GRANARY VENTILATOR

For all your buildings
INEXPENSIVE, BEAUTIFUL, STRONG
Made of heavy galvanized iron. Screened inside. Storm-proof and bird-proof. Perfect ventilation guaranteed. All you have to do is to place ventilator on roof and nail fast.

Write for Illustrated Circular with Complete Prices.

Galesburg Sheet Metal Works,
Galesburg, Illinois

Berger's Metal Lath

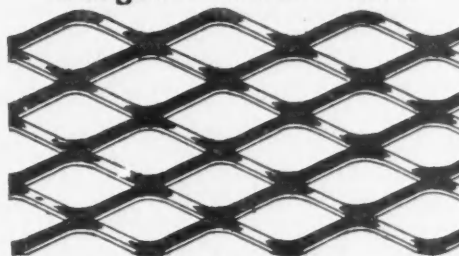

Write for Catalog

The Berger Mfg. Co., Canton, Ohio

For the best service address nearest branch

New York Boston Minneapolis
St. Louis San Francisco Philadelphia

You will get SPECIAL ATTENTION if you tell Advertisers you read American Carpenter and Builder.

The
**Lightning
Estimator**
7th. Edition
PUBLISHED BY
BRADT PUBLISHING CO.
JACKSON, MICH.

CHOOSE

IT'S up to you to be the man
at the top instead of the
man with the dinner pail.

Don't hesitate to grasp this opportunity to win success, for there's always room at the top for the man who knows how.

The LIGHTNING ESTIMATOR

stops worry, lying awake nights, over or under estimating and guessing—in fact, by showing you how to estimate the cost correctly, it spells the word **Success** for you. Don't do yourself an injustice by passing up the greatest opportunity ever offered to Carpenter, Contractor or Builder.

The New Seventh Edition of the LIGHTNING ESTIMATOR

will teach you: How much time and material involved in each part of your work; how to figure on unfamiliar work; how to estimate quickly and correctly on a large job; how to estimate on time, material and prices in all parts of the country.

This Book is written by a man who has made good in this profession, and is based on hard, solid facts, secured by the knocks of experience, making it an invaluable guide to any one engaged in or those about to enter the building business.

If you are just starting out here is your chance to get a firm foot hold. If you are an old timer and getting a little behind the times, here's your chance to brighten up and get some new ideas.

This Edition is bound in cloth, profusely illustrated—a feature not found in other books of this kind. The price, \$1.00. Don't delay. Send for it today.

BRADT PUBLISHING CO.

1260 Michigan Avenue

JACKSON, MICH.

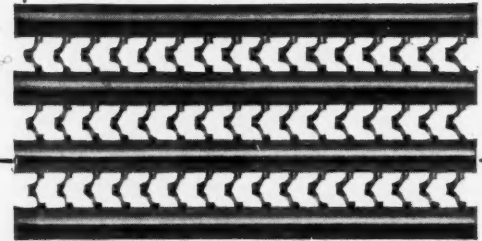

RIB LATH

Rigid—Easy to Plaster—Perfect Clinch

RIB LATH is a superior metal lath with beaded ribs that span between the studs making it exceptionally stiff and rigid, and permitting a wider spacing of studs. RIB LATH provides a perfect clinch for the plaster, which will not streak or crack. Saves time, labor and material in erection. Furnished in three types and nine different weights. RIB LATH on RIB STUDS provide a fireproof hollow partition with open passage for conduits, pipes, etc. Also Detroit Diamond Lath and Steel Corner Beads.

VALUABLE RIB LATH HAND BOOK—Containing details, specifications, tables, illustrations, etc.—FREE to those interested in building.

Trussed Concrete Steel Company

644 Trussed Concrete Building

DETROIT

MICHIGAN.

Reinforcing, Hy-Rib and Lath, Steel Sash, Etc.

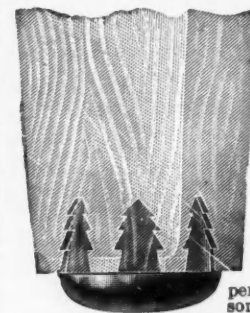

THE QUESTION—

What can I do when not working a few weeks or a few months?

THE ANSWER—

Sell Evergrip Gliding Casters and **MAKE MORE MONEY** than when working at your trade—**MUCH MORE!**

J. R. Stretesky, a carpenter of Bonne Terre, Mo., made in 24 working hours \$51.00. Can you beat it? Hundreds of other carpenters doing as well—some better.

Send for a **FREE Trial Set and Particulars** showing no capital required.
EVERGRIP GLIDING CASTER COMPANY
20 Warren Street Dept. V. New York



Straight-grained cedar that cuts like cheese; smooth, tough leads that make clean-cut, strong marks—that's the way Dixon's Carpenter Pencils are described. Send 16c for generous sample lot 183J.

JOSEPH DIXON CRUCIBLE CO.
JERSEY CITY, N. J.

You will get **SPECIAL ATTENTION** if you tell Advertisers you read American Carpenter and Builder.

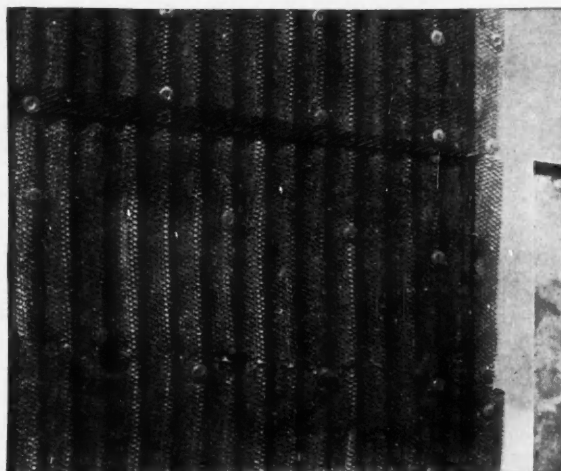

Years of experience and careful tests have taught us how to make



proof against rust and rot. Its mesh construction anchors the plaster firmly to the wall. It is rigid, easy to handle and economical in the amount of plaster used.

Our booklet No. 33 will give you the reasons for every claim we make—reasons that we have not room to give here. It is worth your attention. Let us send it to you.

Over Five Months Exposed to the Weather

—and the lath is as good as ever. This is evidence that appeals to you, Mr. Builder, because it answers the ever-present question of *durability*. The following is quoted from the letter of Franck D. Lawrence, proprietor of a lumber yard at Geneva, Illinois.

“I put the lath (KNO-BURN EXPANDED METAL LATH), over corrugated metal, on the wall of my office building early in May, with the intention of applying stucco at once; but, owing to other matters interfering, I did not get around to the stucco work until the middle of November. Before the plastering was done, I went over every foot of the lathing to see that it was in at least fair condition, and I want to say to you that, although we had a great deal of rain, heat and changeable weather during the summer, the metal lath was in just as good condition in November as it was when we put it on over five months before.”

North Western Expanded Metal Co. 903 Old Colony Bldg
Chicago U.S. A.

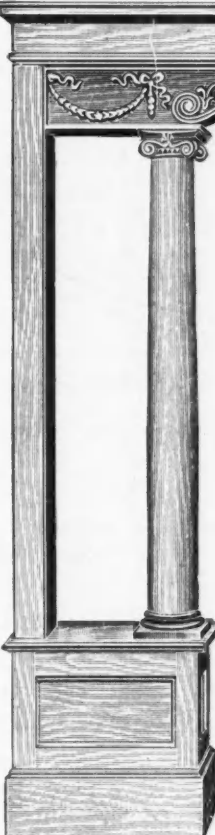

**A Very Interesting Booklet
Just Issued**

— ON —

“Columned Openings”

showing a series of new designs, can
be had free on request.

Ask for Catalogue “U 50”

HARTMANN-SANDERS CO.
*Exclusive Manufacturers of Kolls
Pat. Lock Joint Columns.*

Suitable for Pergolas, Porches or
Interior use.

Main Office and Factory—
Elston and Webster Aves., Chicago, Ill.

Eastern Office—
1123 Broadway, New York City

Catalogue “U 28” on Pergolas, Sundials and
Garden Furniture, or “U 40” on Wood Columns

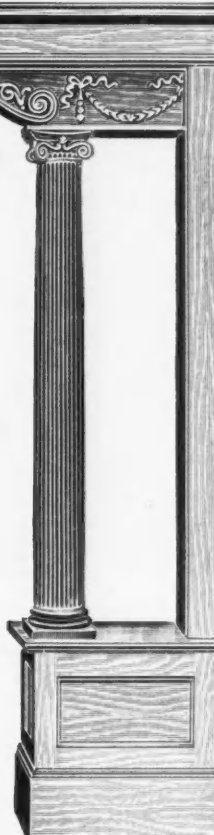

You will get **SPECIAL ATTENTION** if you tell **A dvertisers** you read **American Carpenter and Builder**.



Send \$1.00 for Sample lock and Agent's Proposition.

No Keys

MERELY PRESS THE BUTTONS

HERE'S A LOCK that requires **No Key**—no knobs to turn—no clicks to count. To open it, just put your fingers on the buttons—the right buttons, and pinch—just a little bit. It flies open at once. But if you don't know the right buttons, you cannot open it—and you cannot pick it, for there's nothing to pick. Opening the No-Key Padlock when you know the combination is just as simple as turning on the electric light.

Abolish the Key Nuisance

Notice the buttons numbered from 1 to 8. Eight buttons are on each side, any of which may be included in a combination. Padlocks are set on different combinations, and as more than 40,000 are possible, each purchaser is assured of a combination known only to himself. The No-Key Padlock is made of solid brass and bronze, without a bit of iron or steel to rust out. It will last a lifetime. Made in one size only—weight 5½ ounces.

It is the mission of the No-Key Padlock to do away with keys—to save time, money and pockets. It is simple and practical—a device valued by every man, clerk or manufacturer, cattleman or lawyer, blacksmith or editor, whether his home is on a farm, a ranch, in a city or village—regardless of his vocation.

THE EDWARDS MANUFACTURING COMPANY

Iron and Steel

401-417 Eggleston Avenue
CINCINNATI, OHIO

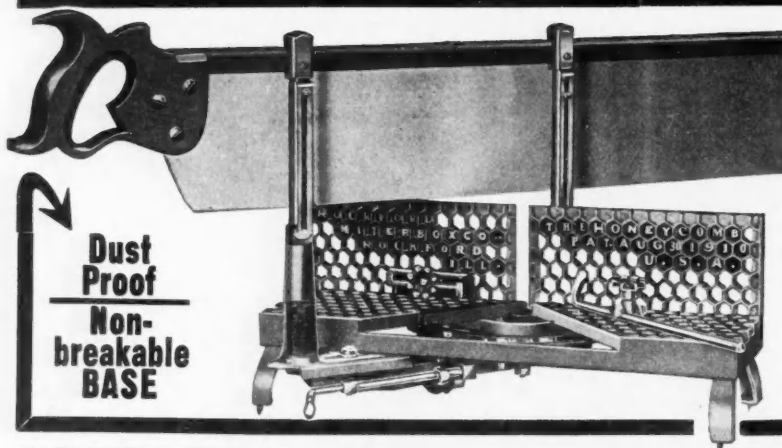

Dust Proof
Non-breakable
BASE

AN OFFER TO CARPENTERS AND BUILDERS

We want one of our new improved Honeycomb Mitre Boxes in every community, and will sell one box at wholesale, to Carpenters and Builders where they are not handled by the dealers.

The Honeycomb Mitre Box is the BEST of all good Mitre Boxes, is more easily kept in good condition, and permits faster and more efficient work. It is also furnished with the best Mitre Box Saw in the world.

Our pride is quality and therefore we give honest opportunity for the purchaser to judge for himself. Each Mitre Box is tagged with our guarantee. We refund the money if 10 days' trial does not prove our guarantee.

Write for descriptive circular and prices.

ROCKFORD MITRE BOX CO.
252 Mill St., Rockford, Ill.

It's the only concern that can furnish a Mitre Box Saw that requires no setting.

Buy 1—Get 3 TOOLS IN ONE Mitre—Square—Line Gauge

If you haven't a Rule Tool Gauge in your kit, order one at once. 25c each, postpaid.

FREE—No. 5 Builders Hardware Catalog and price list to Contractors and Material Men. We do not sell to contractors or carpenters in Cook County, Illinois.

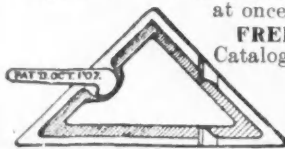

"THE RULE TOOL"

Rehm Hardware Company

1501 Blue Island Avenue CHICAGO, ILL.

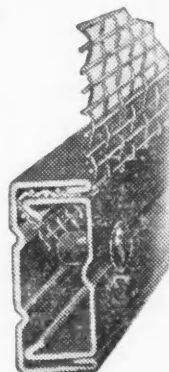

Fly Screens

Metal Frame
REWIRABLE CIN-MAN-CO.

See method of securing wire cloth, held by rounded corners, which prevents cutting by vibration.

Special inducements to
Carpenters and Builders
Booklet Free

The Cincinnati Fly Screen Co.
1010-1026 Evans St., Cincinnati, O.

You will get SPECIAL ATTENTION if you tell Advertisers you read American Carpenter and Builder.

EASY and SURE Steps to Higher Wages and Larger Contracts

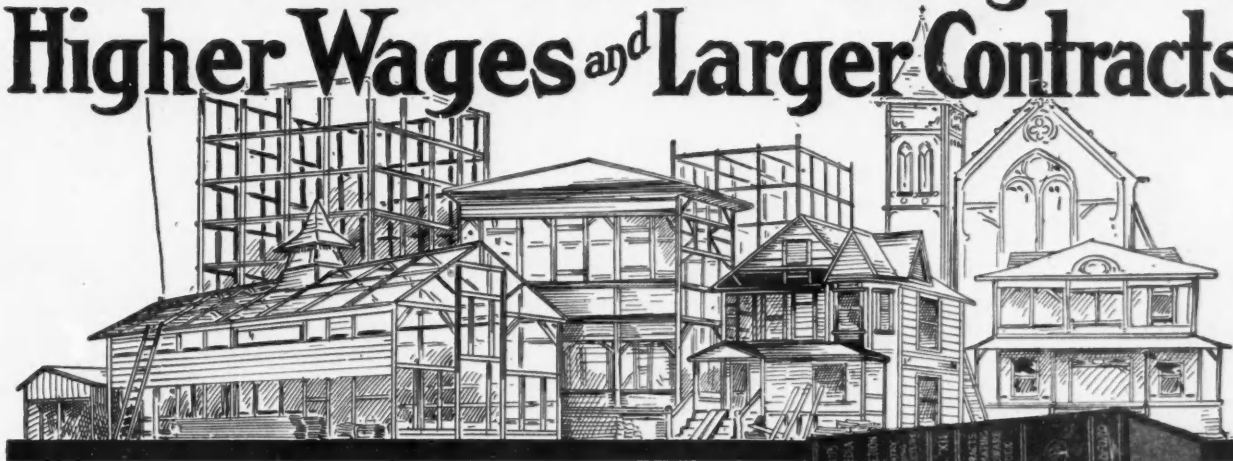

The man who climbs to success is the man who knows how to do things in the best modern way. A bigger share in the

BUILDING OPPORTUNITIES OF TODAY

is surely yours to claim! You can do it without technical training or hard study. To master every detail of your trade or business will be a pleasure instead of a laborious task if you will let us send you for five days' free examination absolutely at our own expense and risk, a set of

RADFORD'S CYCLOPEDIA OF CONSTRUCTION

Carpentry, Building and Architecture

A Practical Uplift to Complete Mastery of Modern Building Methods and Materials

Twelve Massive Vols.—5,000 pages, 3,000 illustrations. Up-to-date, practical, thorough. All in simple English, without higher mathematics. Latest materials and methods. The cream of practical experience of the world's best known builders and contractors. Every detail covered—Carpentry; Framing; Concrete Work; Masonry; Steel Construction; Fire and Waterproofing; Drafting and Design; Heating; Ventilating; Plumbing; Decorating; Contracting; Estimating Cost, etc., etc.

Sent Anywhere on Approval

ORDER ABSOLUTELY AT OUR RISK

No Obligation or Expense to You Unless You Keep the Books
No Follow-Up Agents to Bother You

WHAT OUR FREE TRIAL OFFER INCLUDES:
12 Massive Vols.—Bound in ¼ Morocco leather, with full Persian library covers. A brand new work, costing over \$100,000 to compile and publish, built along new lines especially for the practical builder or contractor. Without magazine, \$1.00 less.

FREE Radford's Portfolio of \$30,000 Prize Building Plans—Over 300 designs of houses, bungalows, outbuildings, apartments, churches, etc. Ranging in cost to suit any purse.

FREE Complete Set of Guaranteed Working Blue-Prints and Specifications for any house design selected from Portfolio—Ordinarily costing \$75 to \$100. We will also include **One Full Year's Subscription to the "American Carpenter and Builder,"** the world's greatest building paper, without extra cost to you.

If you are a Carpenter or Builder, you can do all the ordinary work of the Construction Engineer or Designer without any deep mathematical calculations, thus insuring your title to better recognition, wider responsibilities and higher wages.

If you are a Contractor, your clients will appreciate dealing with a man who is able to give them the latest practical suggestions, and who has back of him the experience and resources of one of the largest architectural firms in the world.

12 MASSIVE VOLUMES

SENT ON APPROVAL FOR FIVE DAYS' FREE EXAMINATION

No Obligation. No Expense. No Risk to You
We Take all the Risk

READ THE COUPON

ON NEXT PAGE

RADFORD ARCHITECTURAL COMPANY,

1827 Prairie Ave., Chicago, Ill.

SIGN AND MAIL COUPON TO-DAY

You will get SPECIAL ATTENTION if you tell Advertisers you read American Carpenter and Builder.

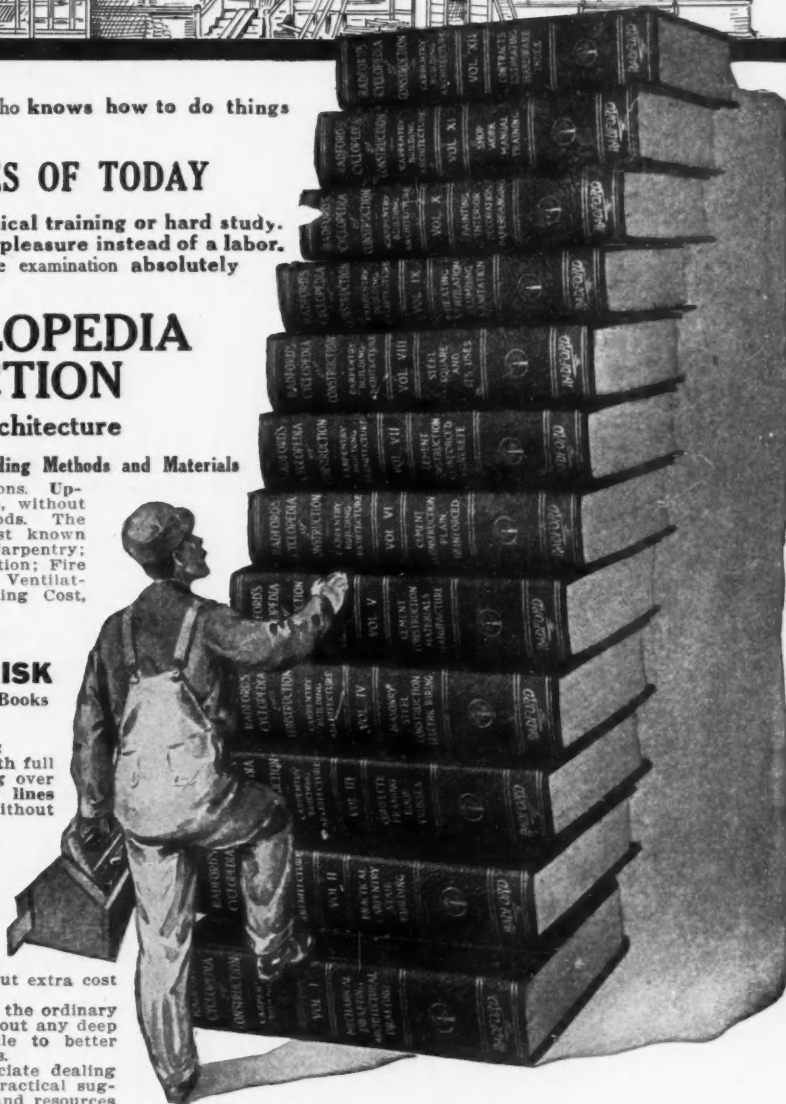

He Waited Too Long



"If I only had this set of books twenty or thirty years ago, they might have changed my whole life. The knowledge in the big CYCLOPEDIA would have enabled me to increase my earning power, to take on big work, paying big money, and possibly have helped me to make a fortune in the building business."

Hundreds of letters like the above have come to us, breathing between the lines the same pathetic story of regret—showing how hard it is for the untrained man to really get ahead in life. **The opportunity is yours NOW**, and the way is easy. **Don't wait too long. Don't wait at all.** Read the terms of our **NO-RISK, Guarantee Offer** over again, and **sign and mail coupon today.** You risk absolutely nothing, and you will reap the benefit ever afterward.

VERY BRIEF LIST OF CONTENTS

To realize their tremendous scope, you must see the books—you can get the books for five days' examination without cost to you.

A.C.B.
2-14.

**Radford
Architectural
Company**
1827 Prairie Ave.,
Chicago

Please send me, express prepaid, your 12-volume Cyclopaedia of Construction, for five days' free examination, with privilege of return at your expense. I enclose \$1.00 deposit, which you agree to return if I decide not to keep the books after examination. If I keep the books, I will pay \$2.00 a month until the special price, \$23.80 is paid, otherwise I will notify you within five days after receipt of books. Your offer also includes Radford's Portfolio of Plans (over 300 designs), and one full year's subscription to the American Carpenter and Builder. You also agree to furnish set of Blue Prints and Specifications, if ordered within 2 months after acceptance of books.

Name.....
Town.....State.....
Street.....

- | | | | |
|---|---|--|---|
| <p>Carpentry.
House Framing
Uses of Steel Square
Rafters Cuts
Strength of Timber
Roof Trusses
Stair Building
Drafting and Design
Working Drawings
How to Read Plans
Blue-Printing
Architectural Forms
Architectural Lettering
Construction Contracts
Forms of Contract
Architect and Owner</p> | <p>Specification Writing
Inspection of Work
Cost Estimating
How to Bid with Safety
Timekeeping, Superintendence
Cement Construction
Origin of Portland Cement
Advantages of Concrete
Common and Hydraulic Lime
Cements (Portland, Natural, etc.)
Proportions for Mixing
Aggregates (Sand Gravel, Crushed Stone, etc.)
Mixing by Hand and Machine
Depositing Concrete
Concrete Troubles
Waterproofing Concrete
Concrete Blocks and Brick
Cement Mortar
Stucco and Plaster
Concrete Machinery and Tools
Concrete Mixers</p> | <p>Block Machines
Number of Blocks Required
Brick and Tile Machines
Forms (Wood, Metal)
Cement Houses
Foundations
Floors and Chimneys
Roofs and Chimneys
Fireproof Construction
Concrete Sidewalks
Ornamental Use of Concrete
Surface Finishes
Art Tile and Mosaics
Terrazzo Floors
Concrete on the Farm
Fence-Posts and Gate-Posts
Sewer and Drain Pipe
Concrete Silos
Reinforced Concrete
Principles of Design
Reinforcing Materials and Systems
Industrial Buildings
Concrete Piles
Sewer and Tunnel Work
Bridges and Viaducts
Culverts, Reservoirs</p> | <p>Estimating Concrete Work
Standard Specifications
Masonry Construction
Building Stone
Brick and Brickwork
Mortar for Masonry
Bonds and Joints
Steel Construction
Steel Shapes
Use of Handbook Tables
Allowable Stresses
Rivets, Tie-Rods
Columns, Beams and Girders
Floor and Roof Arches
Roof Trusses and Coverings
Mill Building Construction
Steel Bridges
Heating, Ventilation
Furnaces and Pipes
Plumbing
Sewers and Drains
Electric Wiring
Painting
Paperhanging
Furniture Making
Useful Tables, Rules, etc.</p> |
|---|---|--|---|

**12 Big Volumes—Free Premiums—No Risk
SENT FOR ONLY \$1.00**

RADFORD ARCHITECTURAL CO.
1827 Prairie Ave., CHICAGO, ILL.

PIN A DOLLAR BILL TO THIS COUPON AND MAIL IT AT OUR RISK TODAY
NO-RISK GUARANTEE COUPON

**SAMPLE
Free!**

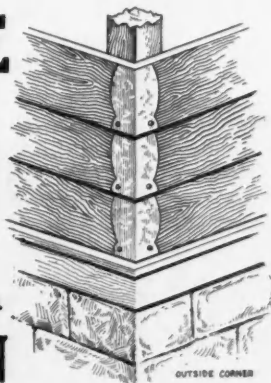

Just drop
a postal for a
**MERWIN
Metal Siding Corner**

We want every contractor, every architect, every carpenter and every owner to know the Merwin Metal Siding Corner.

It Saves **Time
Labor
Lumber**

Used on the best class of frame buildings. It takes paint.

Don't forget—write today—a postal brings it.

MAKERS
OF
"HERRINGBONE"
WALL TIES

MERWIN MFG. CO.
ERIE, PA.

AND
"YANKEE"
PLUGS

Do You Believe

in easily operated and smoothly working sashes? Then

**"American"
Pressed Metal
Sash Pulleys**

will be your first choice. Wide range of sizes; finished to match any hardware. Made with plain, ball-bearing, or roller-bearing axles. Face-plates lacquered, plated, or of solid brass or bronze. Wheels have combination groove for cord or chain.



Send for Catalog

The American Pulley Company

Office and Works, Philadelphia, Pa.

New York

Boston

Chicago

Dealers Everywhere

Pat.

Mullins Metal Tile Roofing

has won widespread and lasting favor because of its many superior qualities. Beauty, simplicity, durability—these are its salient characteristics. Absolutely storm-proof and water tight.

When put on according to directions, Mullins Metal Tile Roofing is guaranteed to keep in perfect condition for years. No other roofing can equal it for all-round satisfaction. Many of the finest buildings in this country are equipped with it.

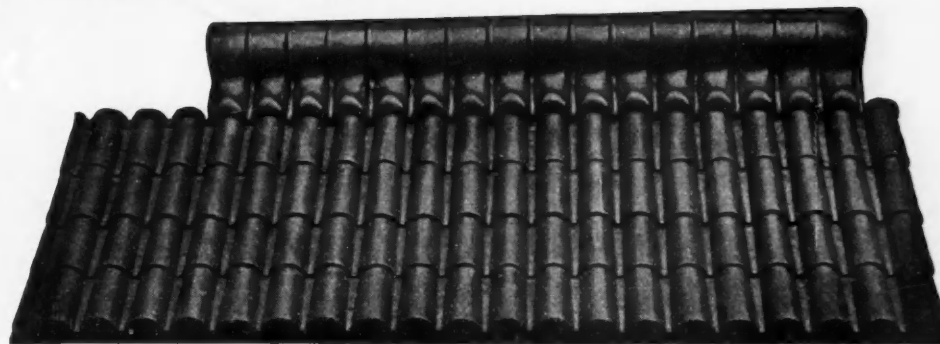

We also make
Cornices, Building
Fronts, Finials,
Tympanum panels,
Rosettes, Faces and
other architectural
ornaments. Many
thousands of de-
signs to select from.

Ours is the
largest and best
equipped factory of
its kind in the
world. We use

only the finest materials. Every artisan in our employ is a masterhand. Our prices are attractive, our services prompt. Glad to submit quick estimates on special jobs.

Catalogue along any desired line will be sent you by return mail.

The W. H. Mullins Co.

214 Franklin St.

SALEM, O.

You will get SPECIAL ATTENTION if you tell Advertisers you read American Carpenter and Builder.

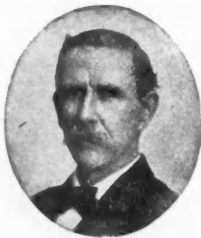

Let me design your CHURCHES

My experience in church work is valuable to you. My knowledge of church architecture assures your getting the most approved, up-to-date designs. The work I have done for hundreds of Builders, Contractors, and various Church Boards throughout the country proves that I can do satisfactory work for you. I can plan a church to meet your needs.

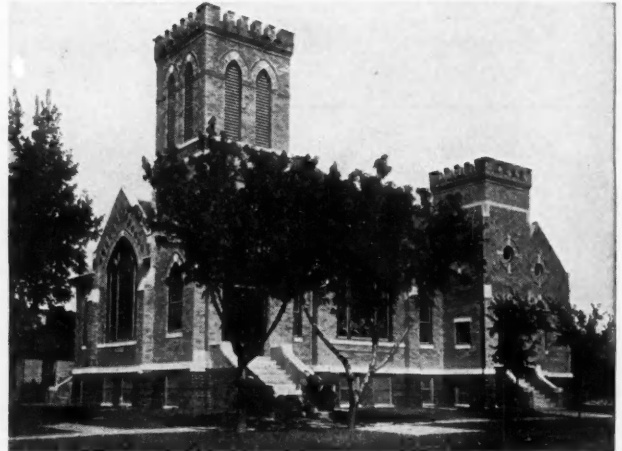

Presbyterian Church

Minden, Nebr.

I CAN SAVE YOU MONEY



First Congregational Church

York, Nebr.

by furnishing plans and specifications at the lowest possible cost. Tell me what you need. Information is free. You pay me only for actual services. Let me show you what I can do for you. Fill out the coupon and mail it. You pay nothing in advance fees and you will not be obliged to give me the work unless I show you that I can do it better, quicker, and at a smaller cost than anyone else.

ALFRED W. WOODS,

—ARCHITECT—

LINCOLN

NEBRASKA

TEAR OFF THIS COUPON and MAIL

Alfred W. Woods, Architect,
Lincoln, Nebraska.

DEAR SIR:—

We propose building a church as per details given below. Please send us information as to what architectural service you can furnish us. It is understood that this information costs us nothing.

Proposed Cost.....

Name.....

Frame, Brick or Stone.....

Denomination.....

Address.....

Seating Capacity.....

Town and State.....

Size and Location of Lot.....

You will get SPECIAL ATTENTION if you tell Advertisers you read American Carpenter and Builder.

Why Tin or Tar? When You Can Use—

BAYONNE ROOF AND DECK CLOTH

Bayonne is a specially prepared canvas. As treated it can be layed dry and painted **after** laying. One coat will do—no sizing required. In addition to wearing longer than tin, tar or other prepared roofing, it can be used for surfaces subjected to much foot wear, like porch floors, decks and roofs. Does not crack, peel, buckle, or leak.

Write today for Sample Book "N". It shows the treatment of the canvas and contains prices and complete instructions

JOHN BOYLE & COMPANY, Inc.
112-114 Duane St., 70-72 Reade St., New York City
202-204 Market St., St. Louis, Mo.

A GAS SYSTEM FOR YOUR BUILDINGS

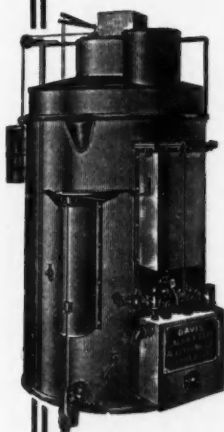

DAVIS GENERATOR

*Big Profits
Easy to Install
Any Carpenter Can Do It
Clean White Light
No Danger from Explosion*

DAVIS LIGHTING SYSTEM

provides the safest means for lighting homes, stores, churches and offices. The best system know for lighting farm houses. Piping can be run to provide barn lights. No leakage; no explosion. Generator will also supply gas for cooking. The most complete, convenient, sanitary system that can be had

WE PAY YOU

to act as our Agent for Davis Acetylene Lighting Systems. We want a reliable man in each town. Write us today and let us tell you how to make money the year around. Good pay; no expense; no risk.

ASK FOR PARTICULARS

DAVIS ACETYLENE CO.,
ELKHART, INDIANA

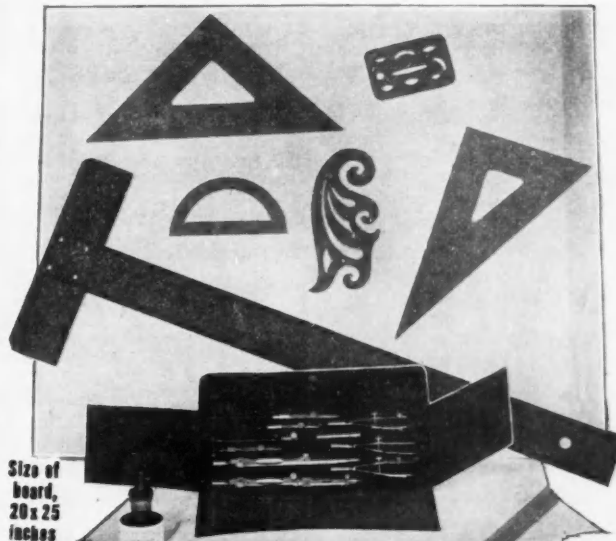

Size of board, 20 x 25 inches

FREE \$20 Outfit FREE \$20 Library

The outfit, exactly the same as those used by architects, engineers and expert draftsmen, consists of imported drawing instruments in morocco case, T-square, triangles, French curve, protractor, triangular scale, ink, pencil, pencil pointer, erasers, erasing shield, drawing paper, etc. Made by one of the largest manufacturers of mathematical instruments in the world.

The library consists of four massive volumes, bound in half red morocco, gold stamped. Contains 1,720 7x10-inch pages, 1,037 illustrations, full-page plates, diagrams, etc., covering completely the entire work of the architectural, structural and mechanical draftsman. Of great value to students as a reference work in connection with the personal instruction of our expert draftsmen.

Remember, the outfit and library—combined value \$40—do not cost you one penny. They are included absolutely free with the course.

Earn \$100 to \$250 a Month

The American School is making this special offer to the many carpenters, contractors and builders who never had a chance to get a technical education. This is a wonderful opportunity for you to get the training you need. Learn drafting—the foundation of architecture—in your own home, and without giving up your work. Our new, easy method will make you an expert draftsman in a short time. If you are a carpenter, contractor or builder it will save you money, for this course will train you to read the modern blueprint accurately. If you want to make drafting your profession, you can earn from \$100 to \$250 per month—it depends upon your ability and the kind of instruction you have had. There is a constant demand for draftsmen—it is one of the few professions where the demand exceeds the supply. Send today for our big free offer. Fill in and mail the coupon now. We will send you our general bulletin and complete information regarding your course.

Seize Your Opportunity

Fill in and mail the coupon today—now! Let us tell you how easy it is to fit yourself for a big job and big pay as a draftsman. Remember, we send you a \$20 drawing outfit and a four-volume reference work of the same value, **absolutely free**, when you enroll. Isn't this worth investigating?

**AMERICAN SCHOOL
OF CORRESPONDENCE**
CHICAGO, U. S. A.



Free Offer Coupon

American School of Correspondence, Chicago, U. S. A.

Please send me full information about the course checked below, also further particulars regarding the drafting outfit and library sent FREE with this course.

- ... Mechanical Drafting
- ... Structural Drafting
- ... Architectural Drafting

Name

Address

A.C.&B. 2-14

You will get SPECIAL ATTENTION if you tell Advertisers you read American Carpenter and Builder.

"Opportunities"

Have you anything to Sell, Barter or Exchange,
Want Help, Agents, or a Situation? Use our

Classified Department

RATES 5 CENTS A WORD. CASH WITH ORDER

No Display Type Allowed in Classified Advertisements

Patents

O. L. PARKER, PATENT ATTORNEY. Formerly member Examining Corps, U. S. Patent Office, 920 G. St., Washington, D. C. Pamphlet of instructions sent upon request.

PATENTS THAT PROTECT AND PAY—Books free. Highest references; best results. Send sketch or model for free search. Watson E. Coleman, Patent Lawyer, 622 F St., Washington, D. C.

PATENTS secured. Legal protection our specialty. HARRY PATTON CO., Suite 355 McGill Bldg., Washington, D. C.

Wanted

WANTED—1000 carpenters to place INVISIBLE LID HINGES on their tool-chests, etc. They sell on sight; no SIDE-TRAPS required. E. R. HANSON, Austin, Minn.

AGENTS WANTED for house lighting machines, supplying gas for small country homes as well as large. Simple and economical. Guaranteed. A live proposition. Write for terms. THE ALEXANDER F. MILBURN CO., Baltimore, Md.

Miscellaneous

CABINET MANTELS direct to builder, \$8.00 to \$40.00. AMERICAN MANTEL TILE & GRATE CO., Hamilton, Ohio.

FREE—\$1.00 Self-Setting Plane Certificate and Pencil, free. See ad., page 24. Self-Setting Planes on trial at Our Risk. GAGE TOOL CO., Vineland, N. J.

Instruction

DRAFTSMEN'S, BUILDERS' AND FOREMEN'S COURSES—Day, evenings or by mail. MAACK'S ACADEMY OF ARCHITECTURE, 1742 Chouteau Ave., St. Louis, Mo.

LEARN THE REAL ESTATE BUSINESS—Our Complete Instruction Book Teaches: Listing, Appraising, Management, Salesmanship, Insurance, Brokerage, Advertising, Renting Agency, Forms, Etc. 121 Subjects. Excels \$20.00 Correspondence Course. Buckeye Cover 75c. Silk Cloth \$1.00, postpaid. REALTY BOOK COMPANY, 5999 Euclid Ave., Cleveland, Ohio.

For Sale

FOR SALE—One combination Grimm Woodworker. Never used. Write for particulars. Box 372, Quaker City, Ohio.

FOR SALE—Band, Bracket, Rip and Cross-Cut Saws with Tables and Carriers, Turning Lathe, 8-in. Sticker, Boring Machine, Double Shaver, 10½-h.p. vertical Steam Engine with boiler, "Coppa" Gasoline Engine, 12½ h.p.; Belting, Shafting and Pulleys. Machinery in good condition.—FRANK T. JOHNSON, Maquoketa, Iowa.

FOR SALE—Carpenter Shop, wood-working machinery, gasoline power; also house-moving outfit; Model A Ideal cement block machine, 8x8x16, will sell separate. Almost new Triple A floor smoother, half price. Write for terms. E. S. KENNEDY, Sannemin, Ill.

You will get SPECIAL ATTENTION if you tell Advertisers you read American Carpenter and Builder.

THE UNIVERSAL PITCH GAUGE

marks more roof-framing in less time than any other tool or method. Any one pitch — of 100 — in FIVE MINUTES, with 22 cuts, lengths, etc., for each pitch; including plancher, fascia, and parline bevel, etc. This done by those who don't even understand framing. Gauge marks hundreds of irregular hips; octagon hips and jacks; hopper bevels and much more framing. Fits any square. Makes a most perfect stair and brace gauge. Steel nicked.

Price, \$1.00 prepaid. Ten days to test. Money back if returned.

JOHN PARKHILL, Rochester, Minn.

Pioneer Drop Forged Screw Drivers



No. 60

One piece. Bead prevents slipping. Most practical, durable, improved driver made.

Show this ad to your hardware dealer, or write us for catalog.

SOUTHINGTON MFG. CO., Southington, Conn.

THE ZIMMERMAN IRON BASE

is the ONLY BASE having a CENTER BEARING.

It carries the required weight without allowing the corner supports to sink into the floor and prevents the base of column and floor from rotting.

See "SWEET'S" page 956.

S. CHENEY & SON, MANLIUS, N. Y.



Bottom View Showing Center Bearing

PULLMAN AUTOMATIC VENTILATOR

Three sizes—2x12 inches, 3x15 inches, and 4x18 inches. Box of brush brass; hood of black enameled steel; copper screened; brass screws thru-out. Handsome and substantial. Can be installed in lower sash rail of window. Best, cleanest, neatest, ventilator for homes, offices and all buildings. Our line is complete. Prices reasonable.

Write for Free Catalog and Prices.

Pullman Automatic Ventilator Mfg. Co. York, Penna.

Three Tools in One SQUARE LINE GAUGE MITRE

Compact, strong, no loose parts. Guaranteed accurate. Should be in every carpenter's and mechanic's tool kit. If your dealer can't furnish you with "The Rule Tool" send 25c for one post-paid. Pays for itself a thousand times over.

THE RULE TOOL CO., 15 Hermon St., NEWARK, N. J.



"THE RULE TOOL"

Triumph Light

EVERYBODY WANTS BETTER LIGHT. HERE IT IS

This new 100 to 700 candle power light turns up and down like gas. One-third cost of electricity, gas or kerosene. For home, church or store. Anyone can operate. Perfection guaranteed or money back. Write for catalog. (A. C. B.) Dept. 20. Agents Wanted. BRILLIANT GAS LAMP COMPANY 1009 S. Wabash Av., Chicago, Illinois

CYPRESS

(OF COURSE)
**BECAUSE IT'S "THE WOOD ETERNAL"
 & LASTS & LASTS & LASTS & LASTS**



**\$4 PER MONTH BUYS THIS
 VISIBLE OLIVER TYPEWRITER**

Nothing Down—Free Trial. Less than Agents' Prices. Shipped on approval. If you want to keep it, send us \$4.00 a month. Our booklet is worth sending for, because it tells you how to save \$41.50. It's FREE.

TYPEWRITERS DISTRIBUTING SYNDICATE 166N 36 N. Michigan Blvd. Chicago.

CORKS the CRACKS

The Introstile Doorbottom automatically shuts the aperture. Thresholds not needed. Door faces not altered. Durability permanent. Value great for both new and old buildings. Price moderate.



The Introstile & Novelty Co., Marietta, Ohio

Over 1,000,000 Here's What People Want **The Axtell**



A perfectly tight All-Metal Weather Strip for bottom of doors and swinging windows. Saves all from weathers and can be put on any door in 5 minutes at 200% profit. Sells at sight wherever shown. Our price will interest you. Write us.

E. I. Church & Co.
 West Hanover, Massachusetts

In Daily Use



2 Dollars A Month
 Buys a Standard Typewriter.
 Your choice of late style Visibles etc. Prices lower than other cash prices. Perfect machines only. Guaranteed. Ask for catalog 35.

Harry A. Smith 180 N. Dearborn St. CHICAGO, ILL.



Ten Days' Free Trial
 allowed on every bicycle we sell. We Ship on Approval and trial to anyone in the U. S. and prepay the freight. If you are not satisfied with the bicycle after using it ten days, ship it back and don't pay a cent.

FACTORY PRICES Do not buy a bicycle or a pair of tires from anyone at any price until you receive our latest Art Catalog—of high grade bicycles and sundries and learn our unheard-of-prices and marvelous new special offers.

IT ONLY COSTS a cent to write a postal and everything will be sent you FREE by return mail. You will get much valuable information. Do Not Wait; write it NOW!

TIRES, Coaster-Brake, rear wheels, lamps, parts, repairs and sundries of all kinds at half usual prices.

MEAD CYCLE CO. Dept. S-122 CHICAGO

20 Reasons Why You Should Investigate the **SANDOW** Kerosene Stationary ENGINE



It runs on kerosene (coal oil), gasoline, alcohol or distillate without change of equipment—starts without cranking—runs in either direction—throttle governed—hopper cooled—speed controlled while running—no cams—no valves—no gears—no sprockets—only three moving parts—portable—light weight—great power—starts easily at 40 degrees below zero—complete, ready to run—children operate them—5-year ironclad guarantee—15-day money-back trial. Sizes 2 to 20 horsepower.

Send a postal today for free catalog, which shows how Sandow will be useful to you. Our special advertising proposition saves you one-half cost of first engine sold in your county. (184)

Detroit Motor Car Supply Co.
 196 Canton Ave. Detroit, Mich.



DRAWING ROOM OUTFIT, \$3.75
 No Toys. Regular \$6.75 Special \$3.75

Every Carpenter or Builder should have an outfit like this on hand. This outfit can be used for Designing Any Job You Have, from a chicken house to a skyscraper; useful to have around buildings while in course of construction.

OUTFIT consists of Board, T-Square, Triangles, Fine set of Instruments, Scale, Tacks, Pencils, Rubber, Curve, etc. Better outfit for \$5.80, \$8.75 and \$12.50. Send for circular. Money back if not satisfactory in any way. **THE T-SQUARE & TRIANGLE CO., 30-32 Clinton St., Newark, N.J.**

Remit by M. O., Reg., Mail, etc.

**SLASHED PRICES
 ON
 PRINTED LETTER-HEADS**

Size 8 1/2 x 11, Hammermill Bond, white or colors. 500 for \$1.25; 1000 for \$2.00; 3000 for \$4.75. Cash with order. Best work. Lowest prices. Trial proves

PRINTER'S PRICE-WRECKING CO. Dept. 36, 787 Michigan Ave. Detroit

8 Grape Vines, 6 Currant Bushes \$1

All best 3 year old stock. If planted now or early spring will fruit next summer. Should ground be frozen we tell you how to protect and keep them dormant ready for early spring planting. Orders accepted now and forwarded at any future time if preferred. Grapes are Worden, Niagara, Iona, Concord, the best early, medium and late varieties. Large cherry currants. Write for list of our \$1 Friend Makers, consisting of all kinds of Fruit Trees, Berries and Roses.

The Landscape Garden Co., Newburgh, N. Y.

**THE WORLDS GREATEST HAMMERS
 ALL OTHERS OUT OF DATE.**



Smash not thy fingers or Fish Hook the Nails. Do the same work with half the effort. The nail holding feature makes you safe in your Scaffold work.



Get them from your dealer or from us.

DOUBLE CLAW Hammer Co.
 453 Broadway BROOKLYN, N. Y.

**SLATE WE HAVE WHAT
 YOU WANT**

*In Roofing Slate. Slate Blackboards
 Structural and Plumbers' Slate*

SATISFACTION GUARANTEED IN QUALITY AND PRICE
 ASK FOR DELIVERED PRICES

J. K. HOWER, Station, C., Slatington, Pa.
 R. J. KICHLINE, Sales Agent



**Berger's
 Metal Lumber**

replaces wood as a structural material sick for sick. Why not use Metal Joists and eliminate plaster cracks and obtain a vermin-proof, rodent-proof sound-proof and fire-proof floor at practically same cost as with wood joists. Write for catalog.

The Berger Mfg. Co.
 CANTON, OHIO

For the best service address nearest branch
 New York Minneapolis Boston St. Louis Philadelphia San Francisco

You will get SPECIAL ATTENTION if you tell Advertisers you read American Carpenter and Builder.

1872

1913

41 YEARS OF FAIR DEALING

WITH THE
Carpenters, Builders and Contractors

IS YOUR assurance that we can serve you to your advantage. We ask nothing more than a trial. When in need of builders' hardware send us your plans and specifications. Let us bid on your requirements. We can give you better value at a lower price than any other hardware dealer.

**Tool for Every Trade
Electrical Supplies
Contractors' Supplies
Builders' Hardware**

(80,000 Different Items)

Our years of experience, our immense buying power, our reputation have enabled us to place before you the largest assortment of well-known builders' hardware, tools of all kinds, etc., in the country. All the leading manufacturers are represented. Our stock is the pick of the choicest and most reliable.

Your orders will be filled promptly. No delays; no waiting for goods out of stock. You will be entirely satisfied with our selection, for our knowledge of hardware and supplies insures your getting the best. Each piece in every shipment is sorted and labeled from the specifications and packed so the workmen will lose no time in handling.

Let us bid on your next contract. Whether your order is large or small, we appreciate it and give it the individual attention that makes buying from us both pleasant and profitable.

When you are in Chicago, call on us. Let us show you over our big store. Look over our display of "quality" hardware. You will go away with the feeling that we can make good on our promise to give you the best service, the greatest satisfaction, the utmost quality at a moderate price.

Let us Figure on Your Next Bill

ORR & LOCKETT
Established 1872 **L HARDWARE CO.**

14-16 West Randolph St., CHICAGO, ILL.

**LOW
PRICES**

**HONEST
VALUES**

You will get **SPECIAL ATTENTION** if you tell Advertisers you read American Carpenter and Builder.

INDEX TO ADVERTISEMENTS, FEBRUARY, 1914

	Page		Page		Page
American Bell & Foundry Co.....	156	Hall Holmes Mfg. Co.....	15	Parker, C. L.....	168
American Cement Machine Co.....	8	Hanson, E. R.....	168	Parkhill, John.....	168
American Floor Surfacing Machine Co..	4	Hardin Co., John.....	144	Parks Ball Bearing Machine Co.....	18
American Mantel Tile & Grate Co.....	168	Harris Bros. Co.....	159	Patent Vulcanite Roofing Co.....	131
American Pulley Co.....	165	Hartmann Sanders Co.....	161	Patton, Harry.....	163
American Saw Mill Machinery Co.....	20	Haven Mfg. Co., The.....	4	Pearson Mfg. Co.....	154
American School of Correspondence.....	167	Helm Brick Machine Co.....	141	Peck, Williamson Co.....	116
American Sheet & Tin Plate Co.....	142	Heppes Co.....	108-128	Pennsylvania Saw Co.....	30
Andrews Heating Co.....	113	Hess Warming & Ventilating Co.....	152-156	Pettyjohn Co., The.....	157
Arkansas Soft Pine Mfrs. Assn.....	107	Hewitt-Lea-Funck Co.....	95	Phoenix Sliding Blind Co.....	7
Ashby, Geo. W.....	150	Holland Furnace Co.....	117	Plastergon Wallboard Co.....	143
Atkins & Co., E. C.....	2	Horan, Timothy F.....	24	Prentiss Vise Co.....	20
Atlantic Engine Co.....	18	House Movers Supply Co.....	24	Printers Price-Wrecking Co.....	169
Automatic Sash Holder Mfg. Co.....	6	Hoyer, J. K.....	169	Progressive Mfg. Co.....	26
		Hurley Machine Co.....	4	Frybill, P.....	18
		Huther Bros. Saw Mfg. Co.....	30	Full-Easy Mfg. Co.....	141
		Hydraulic Press Brick Co.....	125	Pullman Automatic Ventilator Mfg. Co.....	168
		Ideal Concrete Machinery Co.....	118	Queen Gray Co.....	24
		International Correspondence Schools...	149		
		Introstile & Novelty Co.....	169	Raber & Lang Mfg. Co.....	8
		Ives Co., The H. B.....	147	Radford Architectural Co.....	163-164
				Realty Book Co.....	168
		Jackson & Bro., E. A.....	22	Rehm Hardware Co.....	162
		Jaeger Machine Co.....	123	Reynolds Asphalt Shingle Co., H. M.....	127
		Jahant Heating Co.....	156	Richards Wilcox Mfg. Co.....	154
		James Mfg. Co.....	140	Robertds Mfg. Co.....	146
		Jennings & Co., C. E.....	28	Robinson Cabinet Mfg. Co.....	122
		Johns-Manville Co., H. W.....	106	Rockford Mitre Box Co.....	162
		Johnson, E. J.....	26	Ross & Co., G. M.....	143
		Johnson, Frank T.....	168	Royal Ventilator Co.....	139
		Johnson & Sons, S. C.....	99-100	Rule Tool Co.....	168
				Russell Jennings Mfg. Co.....	29
		Karol, B. B.....	156		
		Keasbey & Mattison Co.....	127	Samson Cordage Works.....	18
		Kees Mfg. Co., F. D.....	147	Sand & Sons, J.....	114
		Keighley Metal Ceiling Co., S.....	147	Sanitary Chemical Closet Co.....	102
		Keith, M. L.....	145	Sargent & Co.....	34
		Kennedy, E. S.....	168	Sargen Derrick Co.....	12
		Keppinger, G. J.....	5	Schlueter, M. L.....	5
		Kewanee Boiler Co.....	133	Sedgwick Machine Co. Works.....	6
		Kissel Motor Car Co.....	112	Seneca Falls Mfg. Co.....	18
		Klauer Mfg. Co.....	147	Servoss Furnace Co.....	133
		Knickerbocker Co., The.....	14	Sheldon Slate Co., F. C.....	129
		Kokomo Fence Machine Co.....	142	Sherman Mfg. Co., H. B.....	27
		Kolesch & Co.....	24	Shultz All Steel Corner Post Co.....	32
				Sidney Elevator Mfg. Co.....	6
		Lacey, Elmer B.....	28	Sidney Tool Co.....	19
		Landscape Garden Co.....	169	Silver Lake Co.....	20
		Lane Bros. Co.....	28	Simmons Hardware Co.....	139
		Lansing Co.....	13	Simonds Mfg. Co.....	34
		Lansing Motor & Pump Co.....	148	Sioux City Engine & Machinery Co.....	12
		Lorenzen & Co., Chas. F.....	22	Slatington Slate Co.....	131
		Lowe Bros. Co.....	145	Smith, Harry A.....	169
		Lufkin Rule Co.....	33	Smith & Hemenway Co.....	32
		Luther Grinder Mfg. Co.....	115	Smith Co., The T. L.....	121
				Southern Cypress Mfrs. Assn.....	169
		McGray Refrigerator Co.....	157	Southington Hardware Co.....	137
		McCreery Mfg. Co.....	125	Southington Mfg. Co.....	163
		McHenry Millhouse Mfg. Co.....	124	Spedel, J. G.....	6
		Maacks Academy of Architecture.....	168	Spiegel, May Stern Co.....	132
		Mack & Co.....	33	Standard Scale & Supply Co.....	10-11
		Mack Iron & Wire Works.....	158	Standard Screen Co.....	12
		Mastic Wall Board & Rfg. Mfg. Co.....	172	Standard Stained Shingle Co.....	126
		Mayhew Co., H. H.....	28	Stanley Rule & Level Co.....	27
		Mead Cycle Co.....	169	Stanley Works, The.....	139
		Merwin Mfg. Co.....	165	Star Expansion Bolt Co.....	29
		Metallic Batten Co.....	36	Stark Rolling Mill Co.....	146
		Miami Cycle & Mfg. Co.....	97	Starrett & Co., L. S.....	25
		Midland Terra Cotta Co.....	103	Stearns & Co., E. C.....	4
		Milburn Co., Alexander.....	168	Stillwell & Co., E. W.....	129
		Miles Mfg. Co., The.....	8	Swan Co., Jas.....	154
		Miller Lock Co.....	30	Swarts, H. D.....	125
		Miller Mfg. Co., A. W.....	151	Sykes Metal Lath & Rfg. Co.....	158
		Millers Falls Co.....	26		
		Milwaukee Corrugating Co.....	129	Tannewitz Works, The.....	20
		Miotke, Jos.....	5	Taylor Mfg. Co., Jas. L.....	25
		Moeschl-Edwards Corrugating Co.....	127	Thomas & Armstrong Co., The.....	130
		Monarch Self Feeder Co.....	12	Triple A. Machine Co.....	7
		Moorman & Otten Co.....	22	Trussed Concrete Steel Co.....	160
		Morrill, Chas.....	36	T-Square & Triangle Co.....	169
		Mullins Co., The W. H.....	165	Typewriters Distributing Co.....	169
		Murphy Varnish Co.....	94		
		Myers & Bros., F. E.....	33	Universal Clothes Drier Co.....	6
		National Lead Co.....	96	VanDoren Mfg. Co.....	154
		National Mfg. Co.....	174	VanGuilder Hollow Wall Co.....	157
		National Sheet Metal Roofing Co.....	144		
		New Way Motor Co.....	135	Warren Knight Co.....	24
		Nicholls Mfg. Co.....	25	Waterloo Cement Machinery Corp.....	9
		North Bros. Mfg. Co.....	29	Watrous Mfg. Co.....	139
		Northern Hemlock & Hardwood Mfrs. Assn.....	143	Weber Mfg. Co.....	7
				Wells Lumber Co., J. W.....	140
		Northfield Iron Co.....	36	White Co., David.....	24
		Northwestern Compo-Board Co.....	143	White Co., The.....	153
		Northwestern Expanded Metal Co.....	161	White Co., L. & I. J.....	151
		Novo Engine Co.....	135	Willis Mfg. Co.....	155
				Witte Iron Works Co.....	135
		Oak Flooring Bureau.....	144	Wolff Mfg. Co., L.....	156
		Ohio Tool Co.....	32	Woods, Alfred W.....	166
		Original Gas Engine Co.....	119		
		Orr & Lockett Co.....	170	York Automatic Dumb Waiter Co.....	6
		Oshkosh Mfg. Co.....	3		
Bangor Slate Mining Co.....	129				
Barnes Co., W. F. & Jno.....	18				
Barrell Co., Wm. L.....	140				
Beach Mfg. Co.....	137				
Beaver Co., The.....	109				
Beckmann Co., The L.....	24				
Bennett Co., Geo. G.....	137				
Berger Mfg. Co.....	152-159				
Bird & Son.....	136				
Blystone Machinery Co.....	12				
Bolte Mfg. Co., The.....	12				
Bommer Bros.....	36				
Bovee Furnace Works.....	149				
Boyle Co., John.....	167				
Bradt Publishing Co.....	160				
Bridgeport Wood Finishing Co.....	101				
Brilliant Gas Lamp Co.....	168				
Brooklyn Metal Ceiling Co.....	147				
Buck Bros.....	33				
Buckeye Saw Vise Co.....	141				
Buffalo Wire Works Co.....	158				
Cabot, Samuel.....	36				
Caldwell Mfg. Co.....	32				
Campbell Heating Co.....	149				
Canton Art Metal Co.....	146				
Canton Foundry & Machine Co.....	152				
Carborundum Co.....	31				
Cement Tile Machinery Co.....	15				
Central Mantel Co.....	22				
Ceresit Waterproofing Co.....	138				
C. H. & E. Mfg. Co.....	23				
Champion Safety Lock Co.....	31				
Chappell Co., Wayvell.....	7				
Chelsea Elevator Co.....	6				
Cheney & Son, S.....	168				
Chicago Grille Works.....	22				
Chicago Machinery Exchange.....	23				
Chicago Millwork Supply Co.....	134				
Chicago Spring Butt Co.....	36				
Chicago Technical College.....	145				
Chief Draftsman.....	173				
Church & Co., E. I.....	169				
Cincinnati Ply Screen Co.....	162				
Cincinnati Tool Co.....	27				
Clover Leaf Machine Co.....	15				
Coleman, Watson E.....	168				
Corbin, P. & F.....	105				
Cortright Metal Roofing Co.....	131				
Crater & Holt.....	143				
Crescent Machine Co.....	21				
Davis Acetylene Co.....	167				
Dennis & Co., W. J.....	152				
Detroit Engine Works.....	148				
Detroit Motor Car Supply Co.....	163				
Detroit Show Case Co.....	6				
Diamond Metal Stamping Co.....	104				
Didrikson, H. P.....	5				
Disston & Sons Co., Henry.....	30				
Dixon Crucible Co., Jos.....	160				
Double Claw Hammer Co.....	169				
Dow Wire & Iron Works.....	158				
Dunn & Co., W. E.....	16-17				
Durametal Weatherstrip Co.....	137				
East Bangor Consolidated Slate Co.....	144				
Edwards Mfg. Co.....	162				
Elite Mfg. Co.....	32				
Eureka Machine Co.....	120				
Evergrip Gilding Caster Co.....	160				
Fairbanks, Morse & Co.....	148				
Fay & Egan Co., J. A.....	111				
Fox Machine Co.....	148				
Fox Supply Co.....	137				
Gage Tool Co.....	24-168				
Galesburg Sheet Metal Works.....	159				
Genuine Bangor Slate Co.....	129				
Gilbert & Bennett Mfg. Co.....	98				
Goodell Mfg. Co.....	32				
Goodell Pratt Co.....	33				
Gordon VanTine Co.....	98				
Grand Rapids Furniture Co.....	110				
Grand Rapids Hardware Co.....	31				

NOTICE TO ADVERTISERS

Forms for the March number of the American Carpenter and Builder will close promptly on February 20. New Copy changes and orders for omissions of advertisements must reach our business office, 1827 Prairie Ave., Chicago, not later than the above date. If new copy is not received by

BETTER WALLS



The Only Wall Board Reinforced with Lath

INSIDE

**TO EVERY
AMERICAN CARPENTER
AND BUILDER**

You can make each building job pay a bigger profit—complete it in less time, save costs of materials and labor, leave home owners delighted—by using the Bishopric System for inside walls and stucco exteriors. Thousands are doing it and putting a neat extra profit in their pockets.

Bishopric Wall Board costs a lot less than plaster. Comes in sheets ready for use. Goes on dry. Hammer and saw all you need to apply it. Just nail sheets to bare studding and walls are ready at once for paint, paper, kalsomine, burlap or any kind of decoration. One man can apply it faster than decorators can follow. No delays for dampness or cold weather.

Bishopric Stucco or Plaster Board equally easy to apply. Saves 50% of material, 50% of laborer's time, and 100% of all after trouble.

INVESTIGATE!

Look into this big money-making proposition at once. Get our Free Book for Builders. Write for it today.



Keyed Lath Keeps Plaster In and Up

OUTSIDE

Bishopric Wall Board for interiors is a *permanent* finish. Can't crack, shrink, buckle or pull loose. Unaffected by dampness or changes in temperature.

To prepare outer walls instantly for stucco, plaster or concrete use Bishopric Stucco or Plaster Board. Comes in handy sheets. Goes on like wall board. Rigid and enduring—won't sag like other backgrounds.

**BISHOPRIC
WALL BOARD**

"CAN'T CRACK, BUCKLE OR PULL LOOSE"

Laths are imbedded in toughened Asphalt-Mastic and surfaced with heavy fibre board. Asphalt-Mastic is fire-resisting and vermin-proof. Laths keep wall board *stiff*.

\$5,000 Anti-Warp Bond

Guarantees against warping, buckling, cracking or pulling loose.

**BISHOPRIC
STUCCO or PLASTER
BOARD**

"DAMPNESS CAN'T PENETRATE"

Frees walls from common sagging fault that ruins homes and builders' reputations. Impervious against winds, dampness, heat. Makes a cool house in summer—warm in winter.

FULLY PATENTED

Both Bishopric Wall Board and Bishopric Stucco or Plaster Board are fully protected under U. S. Patents. They are in a class by themselves.

Free Builders' Book Offer

Send for Bishopric Book, Free Samples of both Bishopric Boards, and complete Architectural Blue Print Plans for Building a Model House. Investigate this now!

THE MASTIC WALL BOARD AND ROOFING CO.
452 ESTE AVENUE, CINCINNATI, OHIO

CENTRAL DOOR & LUMBER CO., Portland, Oregon
Licensed Manufacturers and Distributors for Pacific Slope

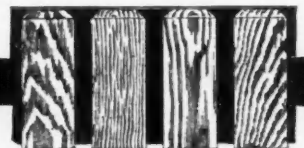

You will get **SPECIAL ATTENTION** if you tell Advertisers you read American Carpenter and Builder.

YOUNG MEN WANTED

To **Become Draftsmen and Designers** At **Once**

The constant demand for trained men always exceeds the supply. Positions paying \$75 to \$100 per week are open now. Some weeks over 250 positions paying the highest salaries in all parts of the country stay open. Let me send you one of my regular weekly "Draftsmen Wanted" lists. You can have one of these positions. I'll give you just the training that you need.

Chief Draftsman Earn \$125 to \$175 Per Month To Start



Will Train You Personally and Instruct You Properly on practical Drafting room work **until** you are perfectly competent and **until** you are placed in a permanent paying position at a salary paying **at least \$125 per month.**

This is a most exceptional opportunity for a limited number of selected ambitious men between the ages of 16 and 40, whom I will train personally and give individual instruction. I am making this special offer in order to fill the constant demand for properly trained men in this line. I give **each** of my students my own **personal attention**—and consequently I must limit the number of students. If you desire such an opportunity, get busy **now** and **write to me at once.** Don't wait till tomorrow, do it **today.** You can earn **more** than I charge for my time and personal training.

You **can** make it. I have trained the highest paid draftsmen and know exactly the kind of training those men need who draw the biggest salaries. In my position as Chief Draftsman, I keep in constant touch with the demands of the profession. I will give you just the kind of training you need—in your own home—during your spare time. **Send the Coupon.**

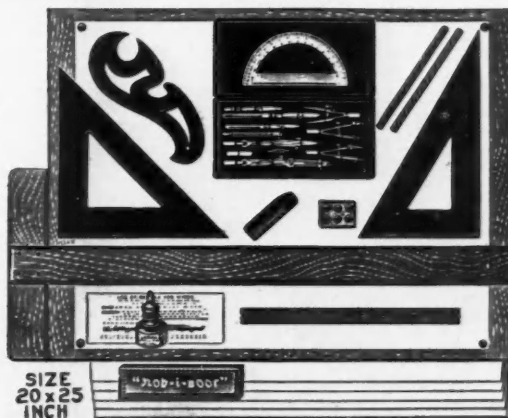

SIZE 20x25 INCH

Earn Big Money at Once

I Guarantee

To instruct you **until** competent and placed in a permanent paying position at a regular Draftsman's salary of at least \$125 to \$175 per month and guarantee to furnish you free the complete Draftsman's working outfit at once from the start.

While You are Learning at Home. Yes, that's exactly what I mean. As soon as you become my student you can begin earning a handsome income while learning at home. I mean just what I say. This is a special offer I am making. Absolutely no obligations of any kind in

sending the coupon. But you must write at once, as I will take the names in the order I receive them.

Send the Coupon

Fill out and mail the free coupon at once for my book, "Successful Draftsmanship," also list of open positions and for the free offer to be earning good money at once while learning at home. This offer is positively limited, and in order to benefit thereby you must act **at once.**

CHIEF DRAFTSMAN Div. 2662 **CHICAGO**
ENGINEER'S EQUIPMENT CO. (Inc.)

This \$15.00 Draftsman's Working Outfit Free

These are regular working instruments—the kind I use myself. I give them free to you if you enroll at once. The handsome set of instruments shown here is imported and encased in a plush-lined leather case. One of the most exquisite sets I have ever seen. **Send the FREE COUPON today.**

FREE BOOK and EARNING while LEARNING OFFER COUPON

Chief Draftsman, Engineer's Equipment Co., Div. 2662, Chicago, Ill.

Without any obligation to me whatsoever, please mail your book, "Successful Draftsmanship" and full particulars of your liberal "Personal Instruction" offer to a few students. It is understood that I am obligated in no way whatever.

Name _____

Address _____

You will get **SPECIAL ATTENTION** if you tell Advertisers you read American Carpenter and Builder.

Time-Savers

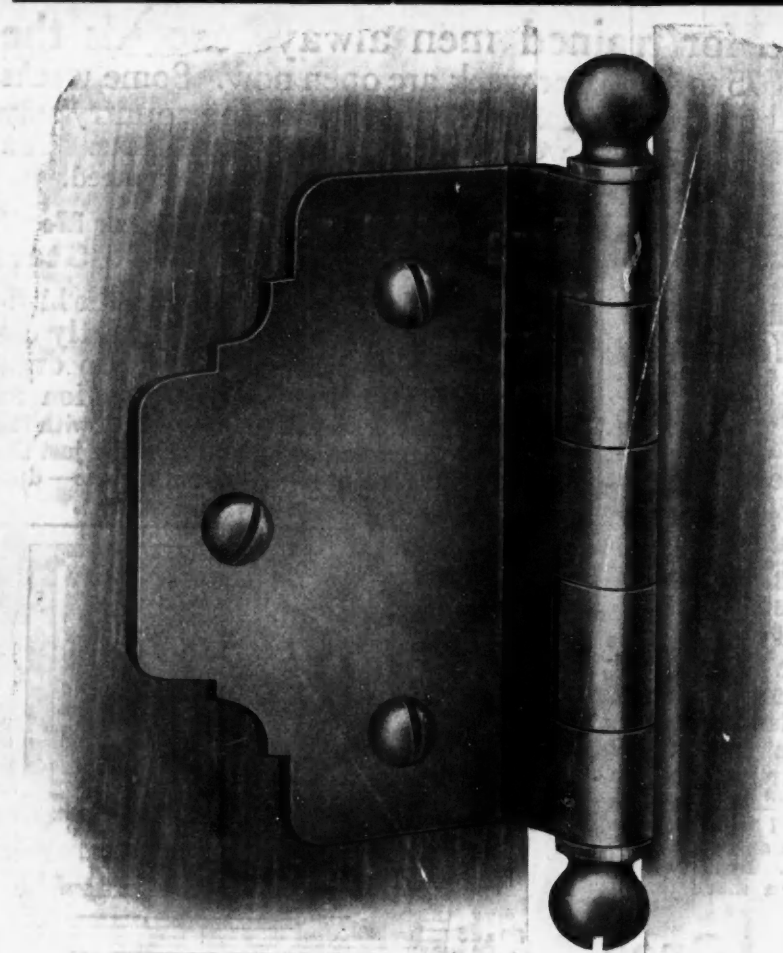

No. 400

50%

of the time required to hang a door can be saved by using "NATIONAL" ornamental Butts. Some contractors say they can save more. Figure up the time spent in a year in hanging doors and you will see how much it is to your advantage to use them.

Another exclusive feature—the new false tip is threaded and screws into the butt. The slot is for a screw driver, making it easy to remove the pin. Also shows which is the bottom of the butt.

STYLE No. 400B

here illustrated can be furnished in any finish and in all sizes from 1½ inch to 4½ inches inclusive.

Ask for Booklet "Ornamental Ideas" and give us your dealer's name.

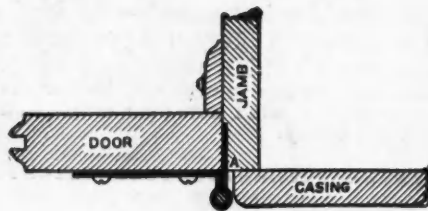

Directions—Attach butt part "A" to jamb first, then set and wedge door into position and attach Ornamental Leaf to surface of the door. Simple, isn't it?



Trade-Mark

Be sure to look for the flag—it's stamped on all "National" Butts—It stands for quality.

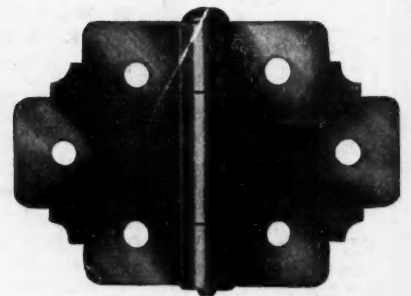

National Manufacturing Co.

Sterling, Ill.