

Clem Labine's **TRADITIONAL BUILDING**

The Professional's Source For Historical Products

JULY/AUGUST 1993 ■ VOLUME 6 NUMBER 4 ■ \$3.00

In This Issue

VICTORIAN REVIVAL PRODUCTS



**Also • Columns & Capitals • Wood Moldings
• Exterior Building Cornices • Chimney Restoration**

Bulk Rate
U.S. Postage
PAID
Permit No. 1
Manchester, N.H.

Traditional Building
69A Seventh Avenue, Brooklyn, N.Y. 11217

Address correction requested.

02/01/99
Merle Easton
Architectural Services
24301 Southland Drive, Suite 200
Hayward CA 94545

CONTENTS

NEW: THE FAX CONNECTION

The Fastest Way To Get Product Information

When an immediate project requires you to get product information RIGHT AWAY, use the new FAX CONNECTION on p. 76. It's the fastest way to get action!

• Companies noted with • have pre-filed their product literature in the 1993 TRADITIONAL BUILDING CATALOG for your convenience. Consult your office copy of the 1993 CATALOG for immediate access to this product data.

SPECIAL FEATURES

Classical Moldings	4
Profile: C. Dudley Brown	5
Chimney Restoration	9
Exterior Cornices	14
Wood Moldings	22
Columns & Capitals	30
Victorian Revival	41
Book Reviews	76
FAX Connection	76
Product Literature	77
Siegel's Scratchboard	78

Division 1 PROFESSIONAL SERVICES



RELATED PRODUCT ADVERTISING

Restoration '93 Congress/EGI	71
PRG, Inc. -- Preservation Supplies	6
Yazoo Mills	6

Division 2 SITEWORK

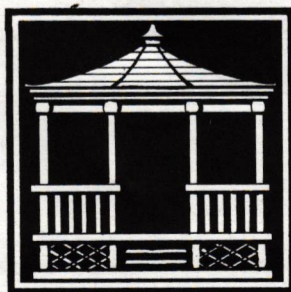

IN THE NEWS

Cast Stone Environment	6
------------------------	---

RELATED PRODUCT ADVERTISING

• Classic Garden Ornaments, Inc.	7
----------------------------------	---

Custom Structures, Inc.	7
Hennessy House	7
Lynch & Sons	6
Murdock Fountains	7
Ruffner and Company	7
Timeless Garden	7

Division 4 MASONRY

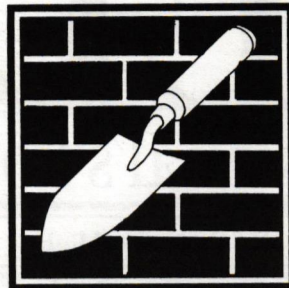

SPECIAL REPORT: CHIMNEY RESTORATION

IN THE NEWS

Chimney Safety	9
Chimney Products SourceList	10
Chimney Products Portfolio	12

RELATED PRODUCT ADVERTISING

• Ahrens Chimney Technique	13
• Benson Chimney Control	11
Brickyard	13
Certified Chimney Contractors	13
Fireplace Technologies, Inc.	11
• Golden Flue Systems	9
Homestead Chimney	11
Lyemance International	11
• National Supafu Systems	11
• Old Virginia Brick Co.	11
ProTech Systems	11
Rutland Products	11
Watson Bowman Acme Corp.	8
Z-Flex	9

Division 5 METALWORK

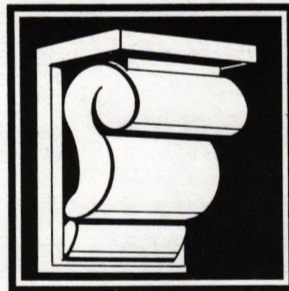

SPECIAL REPORT: EXTERIOR CORNICES

IN THE NEWS

Specifying FRP Cornices	14
Exterior Cornices SourceList	16
Exterior Cornices Portfolio	18

RELATED PRODUCT ADVERTISING

Alpha-One Fiberglass Exteriors	20
Architectural Facades Unlimited	17
• Architectural Fiberglass Corp.	19
Art Home Studios	21
• Boston Valley Terra Cotta	21
Campbellsville Industries	17
Crosswinds Gallery	13
Fiberglass Specialties Inc.	20
Fischer Artworks	13
• Historical Arts & Casting	21
Kent, LP Corp.	17
Kucera, David	21
Lake Shore Industries	13
Midland Engineering Co.	19
Miller Ornamental Sheetmetal	19
Molded Fiber Glass	20
Molloy and Associates	20
Rocca Noto Sculpture Studio	19
Salt & Chestnut Weathervanes	13
Seal Reinforced Fiberglass	20
• Smooth-On	19
Vulcan Supply	19

Division 6 WOOD & PLASTICS

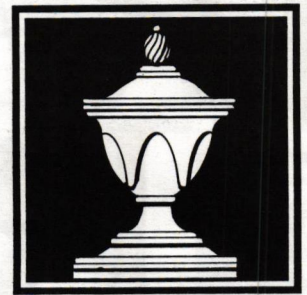

SPECIAL REPORTS: WOOD MOLDINGS COLUMNS & CAPITALS

IN THE NEWS

Wood Moldings SourceList	24, 26
Wood Moldings Portfolio	28
Columns & Capitals SourceList	32-36
Columns & Capitals Portfolio	36, 38

RELATED PRODUCT ADVERTISING

A&B Wood Design	29
A&M Victorian Decorations, Inc.	37
• Abatron	29
American Custom Millwork	23
Archicast	37
Architectural Products Mfg. Inc.	39
Ball Consulting	30
Bendix Mouldings	25
Carr Company	23
• Center Lumber Co.	25
• Chadsworth Columns	31
Chesapeake Moulding & Millwork	29
Classic Architectural Specialties	22
Condon Company	22
Counselor Profiles	23
DEC Associates	39
Dawley Woodworking	33
Design Craft, Inc.	29
• Edon Corp.	35
Empire Moulding Company	23
Executive Woodsmiths, Inc.	22
Fagan Designs	33
Fiberglass Masters, Inc.	39
Flex Moulding	23
Forester Corporation	27
Garden Ornament Stone	33
C.G. Girolami & Company	35
• Hartmann-Sanders Co.	30
Henderson, Black & Greene	35
House of Moulding	25
Josef's Art Wood Turning	35
• Mohamad Woodturning Corp.	37
NMC Decoration, Inc.	25
National Hardwood Flooring & Moulding	27
Ornamental Mouldings	25
Outwater Plastic Industries	39
Pagliaccio Turning & Milling	37
Prime Wood Products	29
RI Millwork	29
• Schwerd Manufacturing	33
Somerset Door & Column Co.	39
Strasser & Associates, Inc.	25
Style-Mark	27
Superior Aluminum Products	39
• Techrete Architectural Precast	33
Tuff-Kote Co.	29
• Turncraft	33
Vermont Custom Doors & More	29
• White River Hardwoods	23
Williams and Hussey	22
Wood-O-Rama	27
Worthington Group	37

Division 7 ROOFING



RELATED PRODUCT ADVERTISING

Mullane Copper Products	40
Rising & Nelson Slate Company	40
Tim Jeckering Architects	40

Division 8 DOORS & WINDOWS

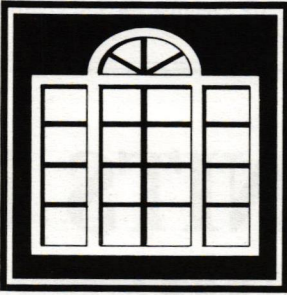

RELATED PRODUCT ADVERTISING

- Allied Windows40
- Midwest Architectural Wood Products40
- Woodstone Company40

Division 9 FINISHES



SPECIAL REPORT: VICTORIAN REVIVAL

IN THE NEWS

- Victorian Reappraised41
- Victorian Products SourceList42-56
- Victorian Products Portfolio58-66
- Gilding Arts School55

RELATED PRODUCT ADVERTISING

- A Carolina Craftsman61
- A-Ball Plumbing Supply41
- A.A. Abbingdon Affiliates, Inc.67
- A.N.T. Art Glass57
- ARS Stained Glass57
- Alloy Casting Co., Inc.67
- Amish Country Gazebos69
- Anthony Wood Products, Inc.51
- Antique Doorknob Company68
- Antique Hardware Store79
- Architectural Ceramics69
- Art Directions63
- Art Glass of the South59
- Ball & Ball Custom Lighting80
- Ball & Ball Hardware80
- Barker Metalcraft68
- Bathroom Machineries Hardware & Plumbing57
- Beech River Mill Co.59
- Belfor Design Ltd.65
- Blaine Window Hardware, Inc.41
- Bopas68
- Bose Associates70
- Bouvet, Inc.63
- Bradbury & Bradbury49
- Brass Reproduction67
- Brown's Stained Glass Studio57
- Burrows & Co.55
- Burton Woodworks68
- Cassidy Company55
- Charles Rupert, The Shop68
- Chautauqua Doors51
- Chelsea Decorative Metal Co.51
- Classic Accents63
- Classic Illumination47
- Classic Lamp Posts53
- Classic Revivals65
- Conant Custom Brass Lighting59
- Coppa Woodworking55
- Copper Coatings & Patinas70
- Cumberland Woodcraft45
- Cummings Studios65
- DMS Studios51
- Decorator's Supply49
- Denninger Products69
- Designs In Tile59
- Enkeboll Designs49
- Eugenia's Place61
- Ewing Restoration51
- Faux Effects68
- Fe Fi Faux59
- Felber Ornamental Plastering Corp.61
- Fischer & Jirouch Co.55
- Florentine Craftsmen, Inc.69
- Goddard Circular Stairs53

- Golden Age Glassworks69
- Green Enterprises61
- Hardware Plus45
- Hinges and Handles69
- Historic Floors of Oshkosh45
- Historic Shutter & Restoration, Inc.61
- Historic Windows41
- J.T. International49
- Jefferson Art Lighting Company70
- Jefferson Art Studio69
- Johnson, H&R53
- Kestrel Manufacturing69
- King's Chandelier Company65
- Knobs 'n Knockers57
- Lampshades of Antique67
- Lehmann Studios47
- Leo Custom Hardware57
- Mac the Antique Plumber70
- Macartney Classical Woodcarving41
- Mad River Woodworks53
- Maguire Iron65
- Milford Replacement Hardware51
- North Fields Restorations59
- Nowell's Lighting68
- O'Connor Cypress Woodworks41
- Old Wagon Factory53
- Osborn Mosaic Hardwood Floors69
- Peters & Son, Inc.51
- Plaster Cast Designs69
- Polytek Development Corp.61
- Red Baron's67
- Reflection Studios67
- Reggio Register Co.69
- Ron Wiener, Woodcarver69
- Roy Electric Co.51
- Sepp Leaf Products, Inc.53
- Shuttercraft45
- Silver Creek Mill69
- Southampton Antiques53
- Spoon River Millwork68
- Steptoe & Wife55
- Sunflower Shower Co.67
- Sunrise Specialty Company47
- Synair Corporation70
- Thermo-Rite Manufacturing63
- Thibaut Wallcoverings68
- Touchstone Woodworks69
- Unique Designs Mfg.53
- Victorian Collectibles, Ltd.41
- Victorian Lightcrafters Ltd.57
- Victorian Lighting Works51
- Vixen Hill Gazebos65
- Vixen Hill Shutters61
- W.F. Norman Metal Ceilings45
- Washington House of Reproductions69
- Weaver, J.P., Company43
- Wood Factory69
- Wood Visions63
- Zina Studios, Inc.59

Division 10 SPECIALTIES

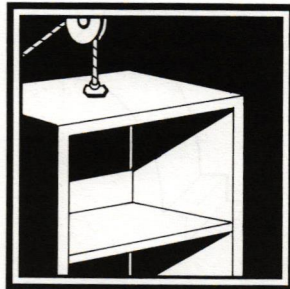

RELATED PRODUCT ADVERTISING

- Nixalite71

Division 16 ELECTRICAL

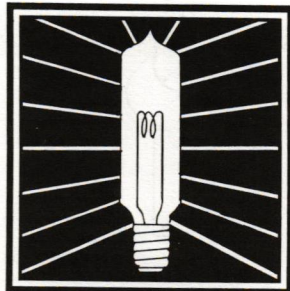

RELATED PRODUCT ADVERTISING

- Gabרון Mediterraneo71
- Leitelt Brothers, Castings70
- Lighting by Hammerworks71
- Roycroft Associates71

Division 17 BOOK REVIEWS

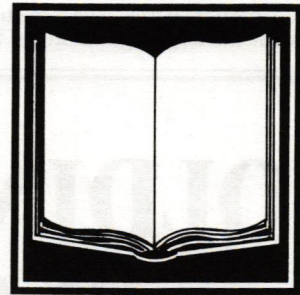

IN THE NEWS

- Victorian Housebook76
- Christopher Dresser76
- Brickwork76

All editorial and advertising material in TRADITIONAL BUILDING is organized according to the industry-standard MASTER-FORMAT divisions established by the Construction Specifications Institute (CSI).

ON THE COVER is Bradbury & Bradbury's newest release: A hand silk-screened Neo-Classical ceiling set, which features 8 separate design components (the 9th — not shown — is a fan rosette) and 28 colors. Designed initially for Victorian Renaissance Revival parlors, this suite of papers is the first of its kind produced in the 20th century. It was designed and produced by BRADBURY & BRADBURY ART WALLPAPERS and was derived from research done at the Cooper Hewitt Museum, NYC, and visits to Renaissance Revival homes on both East and West coasts. What's next? Obviously, the coordinating wall sets, scheduled for an Autumn '93 release. For more information on this company, see its Source-List entry on page 44.

Clem Labine's TRADITIONAL BUILDING

The Professional's Source For Historical Products

69A Seventh Avenue
Brooklyn, NY 11217
(718) 636-0788 FAX: (718) 636-0750

Editor & Publisher **Clem Labine**
Managing Editor **Judith Siegel Lief**
Advertising Director **Susan Littman**
Contributing Editor **Sharon Garbe**
Contributing Editor **Eve M. Kahn**
Art Director **Judith Siegel Lief**
Advertising Representative **Casey Sweet**
Office Manager **Jeanne Baldwin**
Office Assistant **Katya Sverdlov**
Data Security **Magnolia C. Shepherd**
Comptroller **Barry Kornblum**

TRADITIONAL BUILDING (ISSN 0898-0284) is published bimonthly by Historical Trends Corporation, 69A Seventh Avenue, Brooklyn, NY 11217. Telephone: (718) 636-0788, FAX: (718) 636-0750. Subscription rate to professionals in architecture, interior design, construction, and landscape design in the U.S. and possessions: \$18/yr. (6 issues). Rate for nonprofessionals and subscribers outside U.S.: \$30/yr., U.S. funds.

Contents of TRADITIONAL BUILDING are fully protected by copyright and must not be reproduced in any manner whatsoever without written permission from the Publisher.

© Copyright 1993 by Historical Trends Corporation. All rights reserved.

PRINTED AT THE LIGHTHOUSE PRESS
Manchester, New Hampshire

TRADITIONAL BUILDING is indexed
in CONSTRUCTION INDEX.

Largest Gathering Of Classical Designers In 75 Years

On April 24, over 275 architects, interior designers, builders, and craftspeople gathered on the Washington Square campus of New York University to review the work of contemporary designers who are using classical principles to create interior spaces. The large turnout made the one-day seminar the largest gathering of building profes-

sionals interested in classical design in the past half-century. The event was organized and sponsored by Traditional Building Magazine and the Institute for the Study of Classical Architecture. Co-sponsors were the American Society of Interior Designers (N.Y. Chapter), Classical America, and the Classical Architecture League.

The article by Donald Rattner reprinted here is adapted from a presentation he made at the April 24 Seminar. The other 10 speakers covered topics as diverse as using the architectural orders to compose room elevations to harnessing CAD systems for the creation of classical ornament. —CL

MOLDINGS: THE ATOMIC UNITS OF CLASSICAL ARCHITECTURE

When you understand moldings, you understand much about classical architecture — the foundation of all traditional design.

By DONALD M. RATTNER, *Director*

Institute for the Study of Classical Architecture at the New York Academy of Art

When commencing study of the classical elements, it is logical to begin with moldings. Moldings are the smallest physical units — the atoms, as it were — of classical architecture, and so are easier to understand at first than the larger, more complex members formed from their combination. Starting with moldings is also convenient because they crystallize in minute form nearly all the ideas that define classicism itself.

Indeed, the first lesson to be drawn from moldings is that those who work in the classical manner inherit a pre-established vocabulary and grammar. With moldings, the standard alphabet is generally considered to consist of the 14 varieties you see in Fig. 1.

Analysis of shape is one way we classify moldings. On the most elemental level, we first distinguish between *straight* and *curved* moldings. In the former group there are just two profiles: the *fillet* and the *fascia*, which are distinguished by their comparative size. *Fillet* is the term we give to a small, straight member, while *fascia* refers to a large flat profile. This size distinction is relative; the measured size of a *fillet* could be considerable if you're talking about a molding situated on the exterior of a huge building, or small if the *fillet* is part of a piece of cabinetry where profiles tend to be miniature.

Classification of curved moldings is more involved because we have several sub-groups: The *concave*, the *convex*, and the *compound*. In the concave group are the *cavetto*, which is roughly a quarter-circle; the *scotia*, which is actually a curve of greater rotation than a semi-circle; and the *conge*, which combines both straight and curved elements in one profile.

Next are the convex moldings. Those equalling or approximating a quarter-circle include the *ovolo* and a sort of cousin called the *echinus*. The difference between them is mostly a matter of geometry; the *ovolo* is usually drawn with a compass, while the *echinus* is a type of non-circular curve that will be discussed below.

In the half-round class, we have something similar to the condition of the *fillet* and *fascia*. This time, a relatively large half-round is known as a *torus*, and a smaller version is called the *bead* or *astragal*. Another relation to the *torus* is the *thumb*, again the difference being one of geometric method. The *torus* is usually a full half-circle, while the *thumb* is made up of radii of varying lengths, which endows the curve with a directional bias. Moving from the semi-circular, we come to the *three-quarter round*, sometimes known as the *three-quarter bead*, so-called because three-fourths of its perimeter is exposed.

Compound profiles combine both concave and convex elements in a single molding. The *cyma recta*, from the Greek words for "wave" and "upright," is concave above and convex below. Its name is perhaps derived from its resemblance to an upright ocean wave about to crest. Were we to reverse this arrangement, however, and situate the protruding portion above the hollow, then we would discover the aptly named *cyma reversa*.

Finally, we end with the *beak* molding — the most complex of the profile types. The beak is formed from a variety of curved elements, and usually incorporates a chamfer, or diagonal cut. Among the standard types it is the only profile that is undercut. Thus what you see when viewing the molding straight on is unlike what you see gazing up at it from below.

To emphasize the positive nature of mass, classical moldings, with few exceptions, are additive; that is, they usually project out from a given plane.

The Big-Foot Theory of Moldings

So far, we've concentrated on the geometry of moldings. There is another aspect of moldings that I call "The Big Foot Effect." According to that theory, instead of merely seeing moldings as abstract geometric shapes, one might equally understand them as tools that the architect uses to show the observer what the building is experiencing at a given point.

Now, we all know that a building is an object of considerable weight — mostly the weight of its own materials, plus the force of the loads that come onto the building as people, equipment, and weather. We also know a major purpose of a building is to channel those loads to the ground for dispersal. Thus certain portions of the building are continually subject to compressive stresses, much like the human being who has had a great weight dropped onto his or her shoulders. Under the impact of such a weight, a person's knees may buckle, muscles will bulge and flex; in other words, the figure's normally upright silhouette is altered as a result of applied loads. The classical building similarly expresses its loads by contorting itself, the undulating contours of its moldings the equivalent of the body's rippling muscles.

Which profiles will be deployed at a given location will depend on the nature of the dominant stresses there. For instance, where force is directed downward, then an inverted *cyma reversa* might best convey the sense of gravity. However, if it is the release of weight that is to be expressed, such as

occurs at the top of a structure, where the building concludes itself before meeting the sky, then a profile like the *cyma recta*, which places the void above, and thus forms a kind of canopy or sheltering effect appropriate to the top of a building, would be a more logical choice.

Grouping By Function

We can thus re-group moldings, not by their geometrical shape, but according to the architectural function they most clearly perform (Fig. II). Under *crowning moldings*, we place the *cyma recta* along with the *cavetto* and *conge*, each of which ends in a concave curve. The *cavetto* is particularly appropriate for non-supporting situations because most of its section has been voided to form its great concavity, thereby depriving it of significant material strength.

continued on page 72

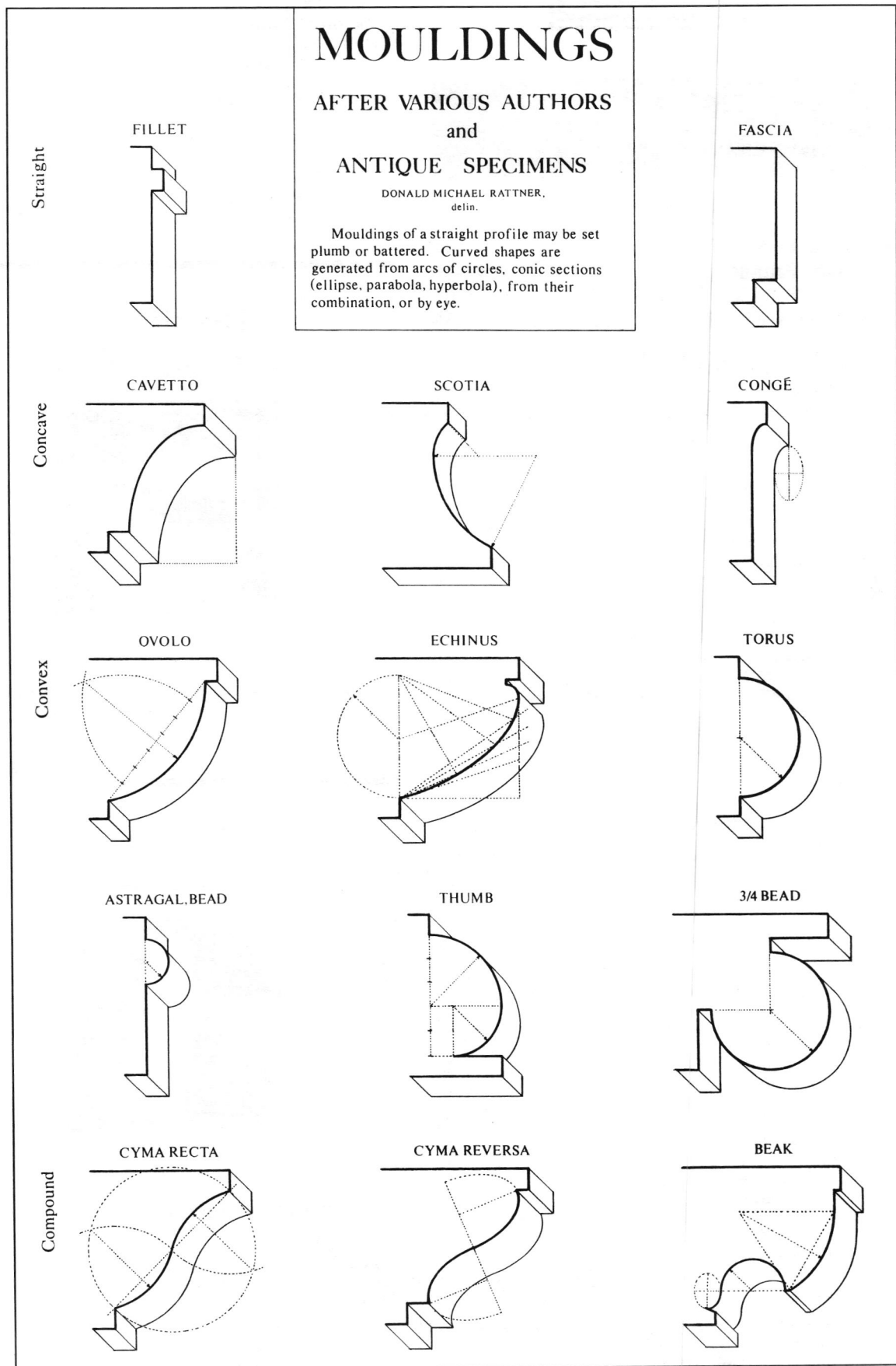

Figure I

profile

C. DUDLEY BROWN, ASID: High Victorian's High Priest

BY EVE M. KAHN

He's dreamed of Victoriana's revival since, oh, World War II, and he's helped make it happen; his lectures are unforgettable, his Victorian-inspired interior designs eminently livable. Now he's basking in the knowledge that the trend has spread far past his wildest imaginings, and he's also drawing on four decades of experience and scholarship to transform a ruined Victorian townhouse into an object lesson in never-say-die restoration.

Spending an afternoon reminiscing with Brown is like watching an erratically paced but indefatigable freight train cross a nation, in this case his own and architecture's and interior design's interwoven pasts. He tells his stories in forcible bursts, making sure to cover the full trail from cradle to present, sometimes reenacting 40-year-old conversations verbatim. Between anecdotes, he manages to devote two hours to a Dutchman-patch-by-patch tour of his almost-finished c.-1885 office-townhouse. His manner is sometimes prim and schoolmasterly, sometimes puckish, sometimes almost bawdy. His watch sometimes runs an hour slow, his car clock an hour fast. His upbeat lens colors most of his clients and mentors through the ages into "grand" or "marvelous" people. You get the sense that, no matter how frustrated he ever felt in dragging Victoriana back into the public's heart, he never stopped having stupendous fun.

When you ask what comes next in his career, he pretends he's ready to coast and nonchalantly replies, "Oh, we'll do whatever comes our way." Yet throughout his Washington, D.C. workplace and 1870 townhouse home, a project or two — or twelve — is busily coming together. On a dining table, a mirrored book rack hovers somewhere in mid-gluing. At the office, a slate fireplace's chipped keystone has regained its contours with a patch, but not yet enjoyed painting. A craftsman has dropped by to pick up a plum-size walnut scrap (the recently rediscovered toe of a worm-infested sofa he's been assigned to rebuild). The tools splayed across the office-backroom's tool wall are so used that they bear little resemblance to the tool outlines traced on the wall for organizational purposes.

"You're not getting it," Brown gently chides a reporter who's addled by attic vistas overflowing with drapery rods and chandeliers and by tales of 10,000



Facade of Brown's 1870 townhouse in Washington's Capitol Hill historic district. The stoop contains the area's only surviving brownstone steps; the facade had been less well treated, and Brown had to replace missing window-hood brackets, cresting, and balconies and to hand-scrape white paint off the facade.

exterior bricks painted brick-color by hand (they were too tar-slopped to leave au naturel) and who can't quite grasp which office-baluster sections came from a salvage yard and which from an expert woodworker's shop. Has any other era in design history ever had its honor defended with such vigor, such meticulousness?

And to think how long it took the rest of the world to catch up with him! Brown's life story, in capsule form, with its constant Victorian thread: He was born in Cleveland, Ohio, eight weeks before the 1929 stock-market collapse. His family slowly

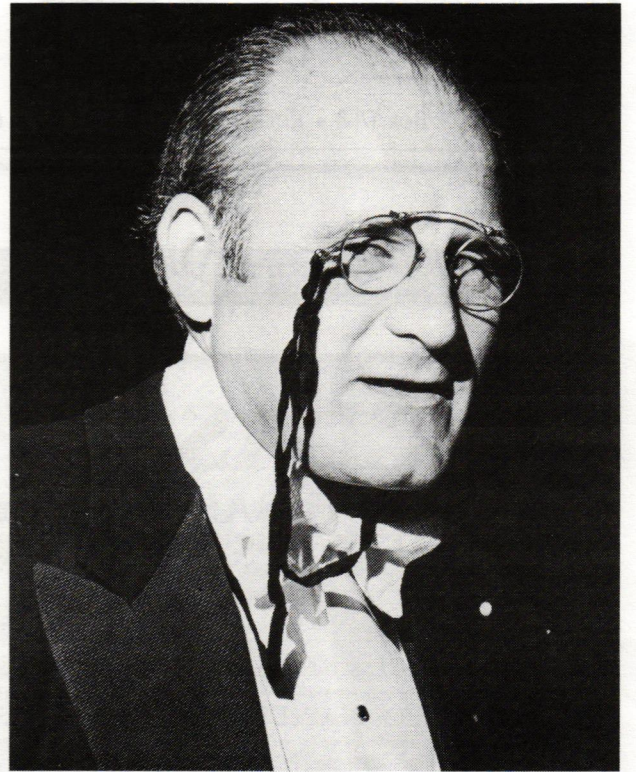

C. Dudley Brown dressed for his favorite era, at a Smithsonian Institution ball.



Brown's parlor. The room had been divided into a living room and bedroom when Brown and his aunt Ruth Spangler bought the building; fortunately, a thoughtful previous owner had stuffed the ceiling's center plaster medallion with newspaper before building a wall under it.

struggled back from financial ruin in Cincinnati (his father ended up running a bank, his mother was an advertising executive, historian, and author). Brown remembers feeling deeply fond of the family's inherited Victoriana and "hypnotized" during vacation visits to Washington-area period homes (Mount Vernon and the Custis Lee mansion, both merely colonial). From age eight he started borrowing every book in the local library on antiques and decorative arts and dramatically declaring intentions to design interiors for a living ("I'm given to those kinds of pronouncements.")

He further explored decoration's history by odd-jobbing at Cincinnati mansions during high school (feeding coal furnaces, polishing brass). Conveniently, the University of Cincinnati offered one of only three college-level design-degree programs in the nation. The courses bored Brown with their Bauhausian lack of historical perspective, but he earned credits in mid-college years by working at a Washington department store's drapery department (where he met numerous future clients). From there he spent two years with the Army Corps of Engineers during the Korean War. He then spent a small family financial gift on a blast through Europe (13 countries, 139 towns, a \$1,000 worth of stuff brought back). He spent the late '50's and early '60's becoming a military-design mogul, specifying hundreds of thousands of square feet of

continued on page 74

Division 1 - SERVICES

**THE SOURCE FOR
PRESERVATION PRODUCTS**

<p>Books & Publications</p> <ul style="list-style-type: none"> Conservation Rehab Maintenance Wood Masonry Moisture Paint Safety Documentation Diagnostics ...and many more 	<p>PRG</p>	<p>Instruments & Tools</p> <ul style="list-style-type: none"> Moisture Meters Crack Monitors Wood ID Kits Salt Detectors Thermographs Hydrographs Light Scopes Electronic Measurers Monoculars Light Sources ...and many more
---	-------------------	---

P.O. Box 1768 • Rockville, MD 20849-1768 • (301) 309-2222

WRITE IN NO. 303

Division 2 - SITEWORK

**CLASSIC
ARCHITECTURAL ORNAMENTAL
METAL & STONE WORK**

BENCHES • GATES • FOUNTAINS & POOLS
SCULPTURE & STATUARY • PLANTERS & URNS
TOPIARY • SUNDIALS • WEATHER VANES

Our Book of Garden Ornament is the handbook of the industry. No landscape architect or professional designer of interior or exterior landscapes can be without one. It contains hundreds of unique products. And gives specifications & sitework suggestions; a price list is included.

KENNETH LYNCH & SONS

TRADITIONAL CRAFTSMEN

DEPT. TB 84 DANBURY ROAD WILTON, CT 06897

(203) 762-8363 FAX (203) 762-2999

- Put my firm on your mailing list to receive FREE product information and specifications data.
- Enclosed is \$9.50... please ship your complete 400-page, hardbound Book of Garden Ornament to my address, below.

Firm _____
 Address _____
 City _____ State/Zip _____

Please Note: Books are shipped UPS, so P.O. Box Numbers are not acceptable.

TUBES IN TIME

High quality shipping tubes for blueprints, mylar & vellum tracings and storage. Factory direct. Immediate shipment. Packed in cartons with end plugs & available in over 30 sizes from stock.

YAZO
MILLS, INC.
MANUFACTURERS OF PAPER TUBES AND CORES
P.O. BOX 369, NEW OXFORD, PA 17350
To order and for more information
FAX 717-624-4420 • TOLL FREE 1-800-242-5216

WRITE IN NO. 930

**Need Information
RIGHT AWAY?**

The FAX CONNECTION Form at the back of this issue is the fastest way to get product data and catalogs. Just fill the form out ONCE and then FAX it to as many suppliers as are appropriate.

Use the FAX CONNECTION on pg. 76

Kudos For A Cast Landscape

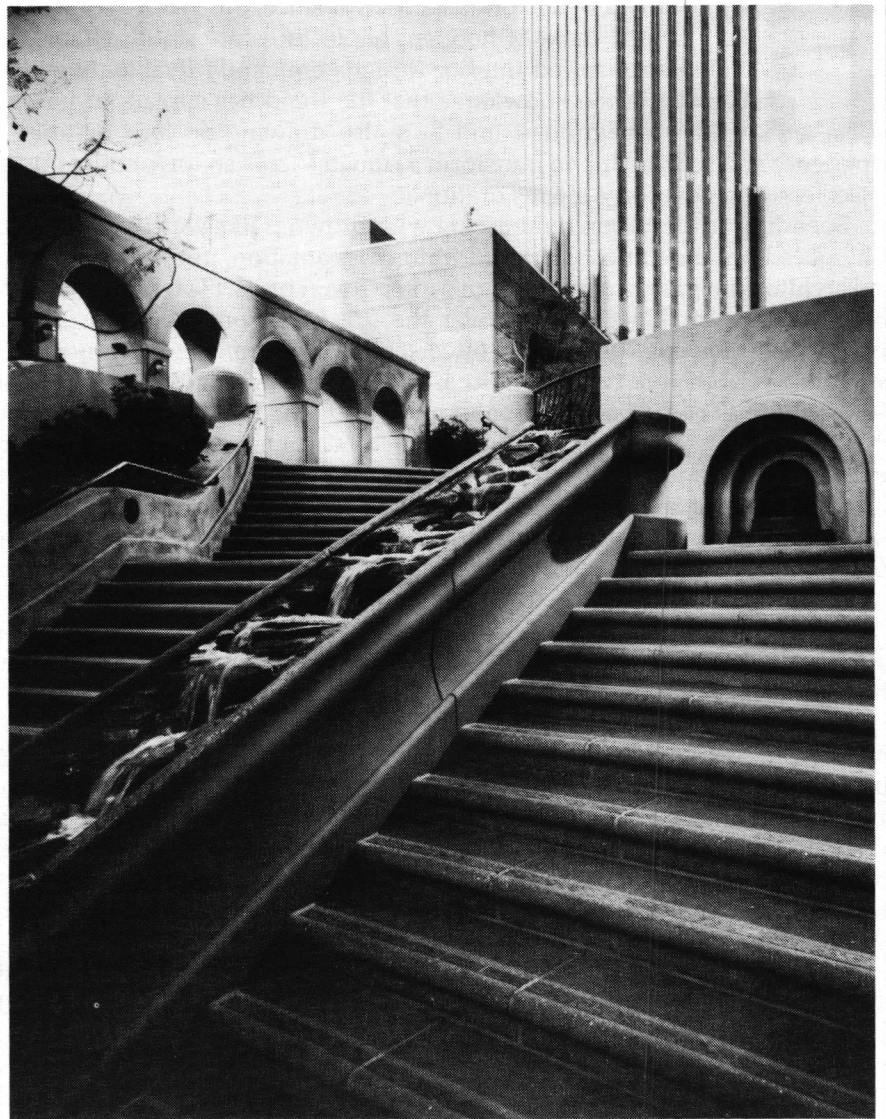

Architectural Cast Stone was awarded the Cast Stone Institute's first annual Design and Manufacturing Excellence Award for their work on the Bunker Hill Steps project designed by I.M. Pei and the Lawrence Halprin Group. The site, located in downtown Los Angeles, connects Fifth Street with Hope Street and the First Interstate World Center.

The design provides elements for both efficient pedestrian traffic and inducements for leisurely strolling or sitting. The site features a series of steps and platforms divided by a cascade of water flowing through an open banister; an arched colonnade punctuating a passageway; and a fountain tucked away in a niche. In a busy commercial area like this, water provides a soothing diversion, and the use of cast stone provides an enduring aesthetic and economic advantage over other materials.

For further information contact: **Architectural Cast Stone, 1201 E. Hunter Ave., Santa Ana, CA 92705 (714) 543-6062.** —SG

It's Really

BIG!

RESTORATION '93 Exhibition & Conference

The largest preservation and restoration event in North America.

**December 6-8, 1993 • Hynes Convention Center
Boston, Massachusetts • See page 71 for details**

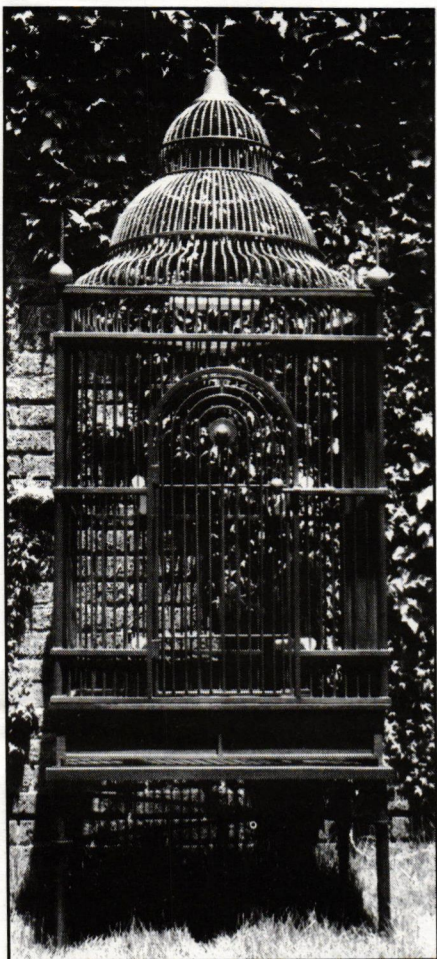

WILLIAM BATEMAN RUFFNER

Handcrafted Bird Cages and Aviaries

Complete Portfolio \$10.00

William Bateman Ruffner & Co.
643 South Peoria • Tulsa, Oklahoma 74120

918-584-0856
Telex 650276-9594
MCI 276-9594

To obtain **FREE** product literature, fill out the enclosed **postpaid card** or use the **coupon** on page 77.

LILY WHITE
A newer member of the Classic Series, this unit is a Murdock original design of the Art Deco inspired 1920s. With polished brass bowl and bubbler, it is a unique addition to any setting. Antifreezing.



MC76-2
One Arm w/Centerbowl
Now available for wheelchair accessibility, these units compliment any historical area. Combination units provide one drinking fountain for both pedestal and wheelchair height necessities.



- **DRINKING FOUNTAINS**
- **HYDRANTS**
- **EMERGENCY SHOWERS and EYE WASH EQUIPMENT**



1776 Old Style
The fountain for theme and historical-style areas. The anti-freezing 1776 is of Murdock's original design with polished brass bowl and mouth guard.



M35 EJECTO SAN
The M35 is anti-freezing with operating valve below frost line. Engineered to prevent ground water contamination. All working parts are removable without digging. Non-pollutible.

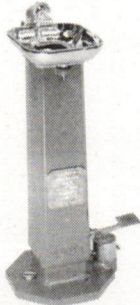

OW40
Nature's most distinctive design in molded poly will withstand the ravages of weather and vandalism. Every OAK-WOOD model comes with Teflon coated bowls and mouth guard; the entire unit color coordinated in rich brown finish.



M30
This most durable and ever popular anti-freezing unit is constructed with all brass parts and stainless steel mainspring. This trouble-free fountain is equipped with automatic stream control ready for year-round use.



HYDRANTS FROM 3/4" TO 2" post & flush box type

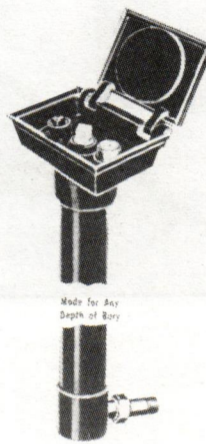

For more information, call or write:
Murdock, Inc.
2488 River Road
Cincinnati, OH 45204
Phone: 513-471-7700 Fax: 513-471-3299

WRITE IN NO. 378

Site Furniture in Wood & Metal



- Benches
- Ash Urns
- Planters • Bollards
- Waste Receptacles
- Stock Models
- Custom designs

C.S.I. CUSTOM STRUCTURES, INC.
P.O. Box 1888, Butler, PA 16003
(412) 282-2712 FAX (412) 283-4713

WRITE IN NO. 339

CLASSIC GARDEN ORNAMENTS, LTD.®
Distributors, Suppliers & Importers of Fine Garden Ornaments

GENUINE ENGLISH LEAD STATUARY, FOUNTAINS & PLANTERS
AUTHORIZED DISTRIBUTOR OF HADDONSTONE LTD.
ENGLISH TEAK GARDEN FURNITURE
MINOAN URNS & WHICHFORD TERRACOTTA
WROUGHT & CAST IRON ORNAMENT & FURNITURE



814 Ridge Terrace • Evanston • Illinois • 60201
Telephone 800 852 2299 • Facsimile 800 634 4429

WRITE IN NO. 333

HISTORIC GARDEN GATES

Beautifully Handcrafted
Authentically Reproduced

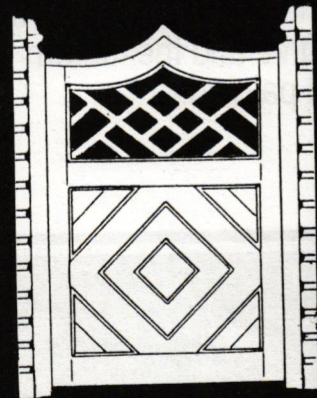

THE TIMELESS GARDEN
P.O. Box #5406
Arlington, VA 22205
(703) 536-8958

WRITE IN NO. 990

WOODEN FLAG POLES



Put the Spirit of 1776 in Your Front Yard.

A few of these prized wooden poles still grace mansions, schools and courthouses across America. We're recreating this era for today's caring home-owner in hand-made wooden beauties with the classic square-to-octagon-to tapered round design.

Made of select Douglas Fir, they're turned on a custom lathe and painted with ten coats to a gloss white finish.

Shipped to your home, ready to install on our rust-free steel base. Poles come with all accessories plus a brass custom-engraved and numbered owner's plaque and 50-star and original 13-star flags. Our poles are made to order and guaranteed to last a lifetime. Can't buy at retail. Allow 6-8 weeks for delivery. Write or call for free color brochure, details. **TOLL FREE 1-800-285-2122**

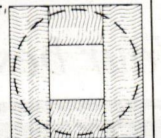

Vertical grain laminated 1 1/4" wall for high tensile, light-weight strength.



Enhancing the grounds of the traditional home.
P.O. Box 57-C, Sierra City, CA 96125

WRITE IN NO. 118

Division 4 - MASONRY

"ProSpec cleaned this eighty year old structure better than the industry leader ...

Vincent R. Bernard, CSI
Senior Associate
Kideney Architects

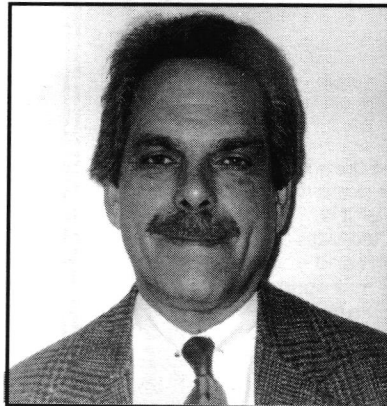

Gordon E. Ebert
Preservation Conservator
Anodyne Consulting Company

... and the rest is history."

Few cleaners and paint strippers, including the industry leader, can handle delicate cleaning projects as well as Watson Bowman Acme Corp.'s ProSpec. The Niagara Mohawk Electric Building in downtown Buffalo, New York is an example of the superior quality achieved by the ProSpec line of masonry cleaners.

According to Vincent R. Bernard, CSI, Senior Associate with Kideney Architects, "I planned to specify a name brand product for the cleaning of this structure when I became aware of ProSpec. The testing application using ProSpec was far superior for this project than the previously selected product. I decided to change the specification mandating the use of ProSpec and I will continue using ProSpec on future projects."

The face of this structure, which is patterned after the Electric Tower of the 1901 Pan American Exposition, is a white matte glazed terra cotta with masonry backup. In 1964, the building was cleaned and sealed with a clear preservative and the lantern portion of the tower was sandblasted and painted.

A recent study of the building's exterior recommended extensive work on the terra cotta using a top-of-the-line cleaner and paint stripper.

"The ProSpec Terra Cotta Cleaner effectively cleansed while preserving the glazed finish on the terra cotta units," according to Gordon E. Ebert, Preservation Conservator at Anodyne Consulting Company.

Architects, specification writers and contractors can trust the ProSpec line of masonry cleaners to return delicate historical structures to their original splendor.

Ask us for more information on the ProSpec line of cleaners, water repellents and strippers. Call or write for your free ProSpec catalog.

ProSpec

Your best connection

**Watson
Bowman
Acme**

WATSON BOWMAN ACME CORP. 95 PINEVIEW DRIVE, AMHERST, NEW YORK 14228 U.S.A. (716) 691-7566 (800) 677-4WBA FAX (716) 691-9239
WATSON BOWMAN ACME INC. 4205 FAIRVIEW STREET, BURLINGTON, ONTARIO, CANADA L7L 2A4 (416) 639-1691 FAX (416) 639-7187
WATSON BOWMAN ACME CORP. 10-08, 10TH FLOOR, BOX 561, FAR EAST SHOPPING CENTRE, 545 ORCHARD ROAD, SINGAPORE 0923
011-65-7328504 FAX 011-65-7322088 TELEX RS 51188 ACTION

WRITE IN NO. 320

CHIMNEY RESTORATION

special report

R_x For Flues: Chimney Restoration Products & Services

BY SHARON GARBE
Having once witnessed the spectacle of a chimney fire, I can attest to the incendiary potential of creosote buildup. Routine chimney maintenance and proper burning of fuel will go a long way towards the prevention of chimney disasters, but other problems — design flaws, improper installation, new appliance adaptations, unlined chimneys, or natural disasters such as earthquakes and tornados — will require more aggressive action.

The following *SourceList* of suppliers and service companies provides the names of chimney professionals who can provide you with the expertise for both restoration and new construction situations. You will find sources for current types of replacement flue liners: Flexible and rigid stainless steel, cast- or poured-in-place cementitious mixtures, and clay tile. There are also companies who offer chimney pots and finials, specialized cleaners, mortars, and paints. In regard to chimney dampers, a couple of companies offer top-mounting models. These

products offer a broad range of advantages, used either by themselves or in conjunction with throat dampers. D.W. Crosby of Benson Chimney Control cites the lower cost of installing a top-mounted variety over the expense and difficulty of replacing built-in throat dampers. (Though not all throat dampers are difficult to replace — it depends on local building codes.) Crosby also notes that the design of his company's product keeps debris, animals, insects, and water out of the chimney, and that they can be useful in controlling chimney fires because they effectively seal off air-intake, thus starving the fire.

A note of caution on the subject comes from John Bitten of The Chimney Safety Institute: Since a top-mounting damper is usually controlled from the firebox, the intensity of some fires may make it difficult to get to the control. Bitten, who has seen and heard of too many chimney tragedies resulting from neglect, stresses the importance of regular inspections and upkeep by trained professionals. ♦

Instant Access to Product Literature for Chimney Repair

If your office qualified to receive the 1993 TRADITIONAL BUILDING CATALOG, you'll find prefilled product literature there for the following suppliers of Chimney Repair products:

- Ahren's Chimney Technique • Benson Chimney Control
- Golden Flue • National Supaflu Systems
- Robinson Flagstone • Techcrete Architectural Precast

Brush Up On The Facts About The Best Chimney Liner Available!

- FACT:** The Golden Flue liner is a specially formulated masonry product made from a naturally insulated material which eliminates heat transfer, the number one cause of structural fires.
- FACT:** Golden Flue is the first and only pumped chimney liner to be tested and approved by Underwriters Laboratories for U.L. Listing.
- FACT:** Golden Flue manufactures several mixes, for historical and residential to high-temperature commercial grades.

If your chimney needs repair, get all the information about Golden Flue Liners from the dealer nearest you or call 1-800-446-5354. And that's a fact!



WRITE IN NO. 174

CHIMNEY SAFETY — Read All About It!

The Chimney Safety Institute of America is a nonprofit organization dedicated to chimney and venting system safety and education about chimney hazards. It offers brochures on chimney-related subjects such as flue linings and chimney sweep certification. Last year the Institute published a comprehensive chimney safety research paper. Titled *Chimney Fires: Causes, Effects & Evaluation*, the 100-page, bound, illustrated document discusses the construction of masonry chimneys; selecting flue linings; sources, causes, and resulting damage of chimney fires; evaluation of other possible causes of chimney damage including lightning, foundation or structural movement, material fatigue, moisture, freeze/thaw damage, etc.; and finally, the application of insurance to chimney fire damage. The Institute is currently working on two more brochures, one of which will address problems with carbon monoxide. The cost of *Chimney Fires: Causes, Effects & Evaluation* is \$20 and can be ordered from: Chimney Safety Institute of America, P.O. Box 309, Dept. TB, Olney, MD 20830 (301) 774-2400.

Z-FLEX® Simple Solutions For All Your Chimney Lining And Venting Needs!

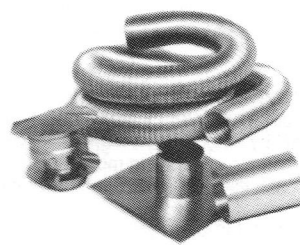

1- Aluminum Chimney Liner Kits

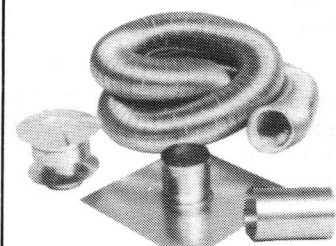

2- Insul-Liner Kit For Gas



3- Stainless Steel Chimney Liner Kits

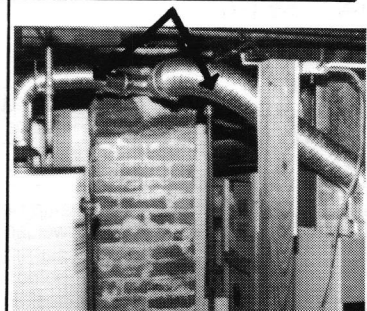

4- Single-Vent™ / Insul-Vent™

Make "all the right connections" with Z-FLEX,® U.S., Inc. We manufacture a kit for virtually every venting need whether it is gas, oil, or solid fuel, going up a chimney or connecting an appliance. Look to Z-FLEX® for economy, ease of installation and quality products backed by warranties and innovative solutions that meet and exceed safety regulations. Call or write today for more information.



U.S. Corporate Office
20 Commerce Park North
Bedford, New Hampshire 03110-6911
(603)669-5136 in NH 1-800-654-5600
Fax 1-603-669-0309

International Office
20 W. Pearce
Richmond Hill
Ontario, Canada L4B1E3
(416)731-9411

WRITE IN NO. 202

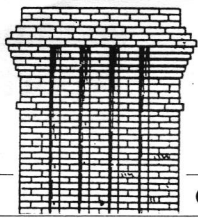

TRADITIONAL BUILDING'S CHIMNEY RESTORATION SourceList

CSI# 04200

COMPILED BY SHARON GARBE

COMPANY	SPECIALTY	Literature	Pots/Caps	Flue Liners	Fans	Dampers	Refractory Repair Materials	Chimney Restoration Services	Other Chimney Products	On-Site Restoration Services
Ahrens Chimney Technique, Inc. 2000 Industrial Ave., Dept. TB Sioux Falls, SD 57104 (605) 334-2827, (800) 843-4417	Company provides a full range of chimney restoration services from chimney relining to minor tuckpointing through a national dealer network, chimney products, tools, and consultation services. Lining systems are U.L. listed.	Free Write in No. 244	✓	✓			✓	✓	Masonry restoration classes, handbook, and tools	✓
Benson Chimney Control 2006 South 1000 E., Dept. TB Salt Lake City, UT 84105 (801) 487-6250	Source for standard and custom dampers (oversize and round). Patented top-mounting damper clamps fast to flue tiles, and is controlled by cable from the firebox. Also used for fire safety, animal, water, odor, and energy control. Very low profile when closed. Airtight.	Free Write in No. 152				✓				
The Brickyard P.O. Box A, Dept. TB Harrisonville, MO 64701 (816) 887-3366	Source for authentic, unused antique clinker bricks with highly distinctive shapes, colors, and textures that are ideal for constructing hearths and chimney facings.	Free Write in No. 396							Clinker bricks	
Certified Chimney Sweeps, Inc. P.O. Box 222 Hasbrouck Heights, NJ 07604 (201) 361-1783	Full-service chimney cleaning and restoration company specializing in all methods of chimney lining: Ahrens, Supaflu, flexible and rigid stainless steel, and terra cotta tile. For residential, commercial, or industrial customers. Also, complete restoration of fireplace and/or furnace flues.	Free Write in No. 428	✓	✓	✓	✓	✓	✓		✓
Chimney Savers 6-9 Ilene Court, Dept. TB Belle Mead, NJ 08502 (908) 359-7798	Specializes in the restoration and relining of existing masonry chimneys using Solid/Flue pumped masonry chimney lining. Company has restored numerous historic structures, such as Gracie Mansion.	Free		✓				✓		✓
Fireplace Technologies 1715 Dixie Hwy, Dept. TB Louisville, KY 40210 (502) 772-1067	Manufacturer of the Lock-Top damper. Stainless lid serves as chimney cap in open position. Opens and closes by high-grade stainless steel spring system. Available in 6 standard flue sizes; easily adapts to round. Non-restrictive; no reported freezing.	Free Write in No. 208				✓		✓		✓
Golden Flue Rt. 3, Box 237, Dept. TB Ruther Glen, VA 22546 (800) 446-5354	Cementitious pumped-in-place lining for single, multiple, straight or offset flues. Applications include historical, residential, commercial, and industrial. Company has nationwide network of highly-trained installers. Product is U.L. listed.	Free Write in No. 174		✓				✓	Chimney lining equipment & tools	✓
Homestead Chimney, Inc. P.O. Box 5182, Dept. TB Clinton, NJ 08809 (908) 537-6456	Total chimney and fireplace restoration, including Z-Flex stainless steel flexible liners, Golden Flue poured-in-place liners, Lock-Top dampers, Gelco Chimney caps, Aerocowl chimney caps, field draft inducers, and Chimney Saver water repellent. Also offers fireplace restoration, and all types of masonry skills.	Free Write in No. 548	✓	✓	✓	✓	✓	✓	Refractory fireboxes	✓
Lyemance International P.O. Box 505, Dept. TB Jeffersonville, IN 47131 (812) 288-9953	Cast-aluminum top-mounting fireplace damper for new or old fireplaces. Product covers terra cotta flue liners of 9 x 13, 13 x 13, and 13 x 18 in. standard dimensions, or can be adapted for smaller flue liners. Lid is spring-loaded in open position; it's closed by a stainless steel cable from the fireplace wall.	Free Write in No. 512			✓					
Minuteman International Co. 75 Sawyer Passway, Dept. TB Fitchburg, MA 01420 (800) 626-1114	Supplies Topseal chimney damper with optional spark screen and JetDraft chimney draft inducer, which increases chimney draft by introducing a high-velocity jet of air at the right location in the chimney to mix with low-velocity flue gases and push the mixture through the chimney.	Free	✓		✓					
National Supaflu Systems, Inc. Box 89 Industrial Park, Dept. TB Walton, NY 13856 (800) 788-7636	Cementitious cast-in-place chimney lining system tested to U.L. standard 1777. Provides fire-safe corrosion-resistant liner that strengthens and insulates chimney, too.	Free Write in No. 164	✓	✓			✓	✓	Sealers for exterior, clean-out doors	✓
Northern Roof Sales Co. P.O. Box 275, Dept. TB Millgrove ONT LOR IVO (416) 627-4035	Distributor of imported handmade ceramic chimney pots and chimney pot finials. Company is also a single source for roof tiles and related accessories.	Free	✓							
Old Virginia Brick P.O. Box 508, Dept. TB Salem, VA 24153 (714) 389-2357	Company offers traditional wood-molded bricks and specialty bricks well-suited for new or restoration chimney facings.	Free Write in No. 90							Bricks	
ProTech Systems 26 Gansevoort St., Dept. TB Albany, NY 12202 (518) 463-7284	Supplies Ventinox chimney lining systems: Continuously welded, airtight flexible liners fabricated from titanium-stabilized stainless steel. Surface is acid-resistant and non-porous. U.L. listed. Thermix insulation fills void between liner and chimney wall.	Free Write in No. 206	✓	✓					Thermix masonry flue insulation	
Rutland Products P.O. Box 340, Dept. TB Rutland, VT 05702 (802) 775-5519	Largest supplier of refractory materials for fireplace and chimney repair. Also carries cleaning products, gasket cements, chimney paint, and water repellent.	Free Write in No. 461					✓		Creosote/soot removers, special mortars, cement, & masonry patch	
Superior Clay Box 352, Dept. TB Uhrichsville, OH 44683 (614) 922-4122	Manufactures chimney pots in traditional styles, clay flue linings, fired-clay Rumford throats, dampers, and smoke chambers.	Free	✓	✓		✓	✓		Firebrick, clean-out doors	
Tri-State Chimney Sweeps 3122 Rt. 10 West, Dept. TB Denville, NJ 07834 (201) 361-1783	Full-service chimney cleaning and restoration company specializing in all methods of chimney lining (Ahrens Cast-in-Place, Supaflu Poured-in-Place, flexible and rigid stainless steel, and terra cotta tile). Also offers restoration of fireplaces. Services residential, commercial, and industrial customers.	Free	✓	✓	✓	✓		✓		✓
Z-Flex U.S., Inc. 20 Commerce Park North, Dept. TB Bedford, NH 03110 (603) 669-5136	Manufactures a broad line of chimney liner products for gas, oil, and solid fuel. Z-Flex Type 316 stainless steel flue lining system can accommodate offset flues and make 90-deg. turns at the firebox. Also offers insulated or uninsulated vent connectors.	Free Write in No. 202		✓					Vent connectors	



NEW POWER LEVER

With Lyemance's new patented Power Lever™ your damper will open every time.

LYEMANCE™ INTRODUCES THE NEW "POWER LEVER"™

- Power Lever™ comes mounted to the damper lid.
- Fully guaranteed for material and workmanship.
- A tug on the cable drives a tiny piston upwards, applying hundreds of pounds of leverage.
- Same low cost.
- No change required for installation.
- Sizes available: 8"x8", 8"x17", 9"x13", 12"x16", 13"x13", 13"x18", 17"x17".

LYEMANCE INTERNATIONAL™

P.O. Box 505 • Jeffersonville, IN 47131
[812] 288-9953 • Fax [812] 283-3692

WRITE IN NO. 512

supaflu®

The Ultimate Flue Liner For Masonry Chimneys

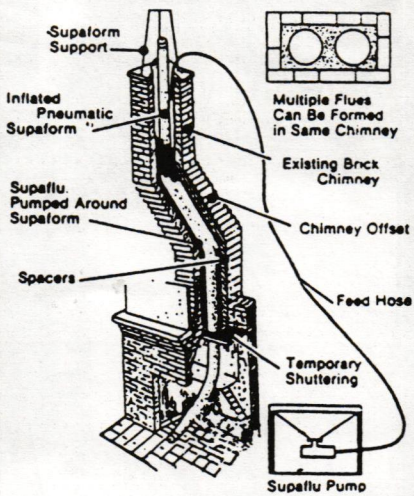

Cast-In-Place Lining

- Seals
- Cures Condensation
- Insulates
- Improves Combustion Efficiency
- Lines & Makes Chimneys Safe
- Impervious to Corrosion
- All in One Process

Tested and Listed by an ASTM and ACIL approved laboratory to UL 103-2,100 F., Canadian ULC-S629-M-1981 and UL Requirements for Non Metallic Chimney Lining System — 1985.

Supaflu is recognized by the International Conference of Building Officials — Report No. 3937.

National Supaflu Systems

Chimney Lining and Relining

P.O. Box 89 Walton, NY 13856
(800) 788-7636

WRITE IN NO. 164

THE ALL SEASON CONTROL COVER™

The damper replacement system for masonry fireplaces

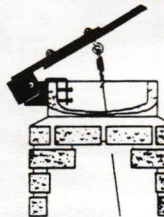

- Replaces worn out or rusted Dampers
- Almost invisible when closed
- Saves energy
- Keeps animals out
- All sizes and shapes
- Operates from fireplace

BENSON CHIMNEY CONTROL
2006 South 1000 East, Salt Lake City, Utah 84105
1-801-487-6250

WRITE IN NO. 152

Homestead Chimney, Inc.

"THE CHIMNEY SPECIALISTS"

- ALL TYPES OF CHIMNEYS
- CLEANED • INSPECTED • RELINED • REPAIRED •
- SAFETY TESTS & EVALUATIONS •
- SCREENS • CAPS • DAMPERS •
- INSTALLED
- ASK ABOUT OUR GROUP RATES

Chim-Scan™
CLOSED CIRCUIT
Internal Chimney Inspection System

Call
908-537-6456 NJ
215-258-8073 PA
1-800-242-7668

Write or Call for Free Brochure
P.O. Box 5182 Clinton,
N.J. 08809



Certified Member of
National Chimney Sweep Guild
INSURED EMERGENCY SERVICE

- GOLDEN FLUE Poured LINERS
- U.L. LISTED
- APPROVED BY BOCA
- INSULATES
- STRENGTHENS
- GUARANTEED
- STAINLESS STEEL CHIMNEY LINERS AVAILABLE

WRITE IN NO. 548



Custom Made

Wood-mould Brick For Your Distinctive Designs

- Pavers & Step Treads
- Rich, Warm Colors
- Water Tables & Copings
- Unique Special Shapes



Box 508
Salem, Va. 24153
(800) 879-8227

Since 1890

WRITE IN NO. 90

These Products Make Your Chimney Repairs Safer & Easier!

DRY MIX 211 Non-Water Soluble Refractory Mortar meets the new NFPA Chimney Flue Safety Standards.

This new formula of calcium aluminate and crystalline silica produces an acid resistant, non-water soluble refractory mortar with a 2500 psi compressive strength for use as an approved flue tile sealant to meet or exceed current building codes. It's easy to work and sets in about 2 hours. Just add water.

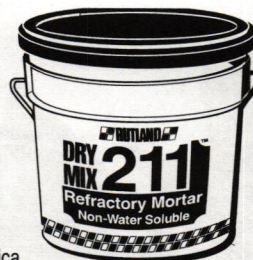

Rutland Fireplace Mortar resists 2000°F temperatures.

Pre-mixed in convenient cartridges, this is the easy way to repair fireplaces, tuckpoint and repair broken firebrick. When cured, it becomes brick hard and brick strong. Comes in black, buff and gray colors.



Chimney Masonry Patch An exterior mastic patching cement in a convenient gunnable cartridge. Repairs and repoints masonry and stone. Concrete color. Non-freezing formula can be applied down to 0°F.

Castable Refractory Cement forms custom firebrick shapes.

Developed for use in blast furnaces, this air set and heat cure formula is ideal for casting custom shapes to replace worn-out firebrick in fireboxes of fireplaces, stoves and furnaces or for making a solid refractory stone bed.



Ask about Rutland's complete line of heating system repair products by name at your hardware, home center, building supply or stove dealer.



RUTLAND PRODUCTS
P.O. Box 340
Rutland, VT 05702-0340
(802) 775-5519
FAX (802) 775-5262

WRITE IN NO. 461

LOCK-TOP

THE OPEN & SHUT SOLUTION

TO FIREPLACE PROBLEMS

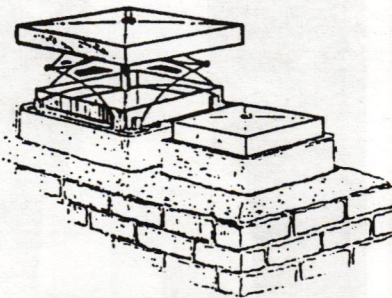

A Chimney Cap That Closes!

- Seals Out Mammals, Birds, and Insects
- Stainless Steep Cap In Open Position
- Adaptable to round relined flues
- Replaces Missing or Ineffective Fireplace Dampers
- Low-Profile Design
- Prevents Heat and Air-Conditioning Loss

Fireplace TECHNOLOGIES, INC.

1-800-737-1067

1715 Dixie Highway Louisville, KY 40210

WRITE IN NO. 208

For instant access to FREE product literature, use the

connection on page 76.

CHIMNEY RESTORATION PORTFOLIO

For more information on these companies, consult the SourceList on page 10.

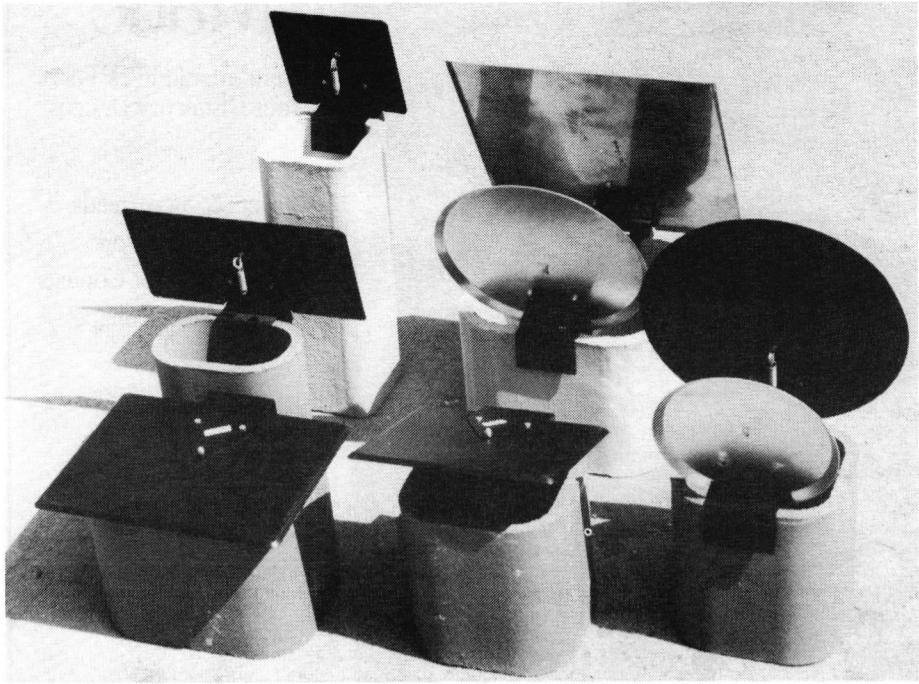

Shown above is a sampling of the standard, oversized, and round top-mounted dampers available from **BENSON CHIMNEY CONTROL**. Write in No. 152



The near-completion of a stove chimney with a cast-in-place liner. As the tube is deflated, it is slid out. **GOLDEN FLUE, INC.** Write in No. 174

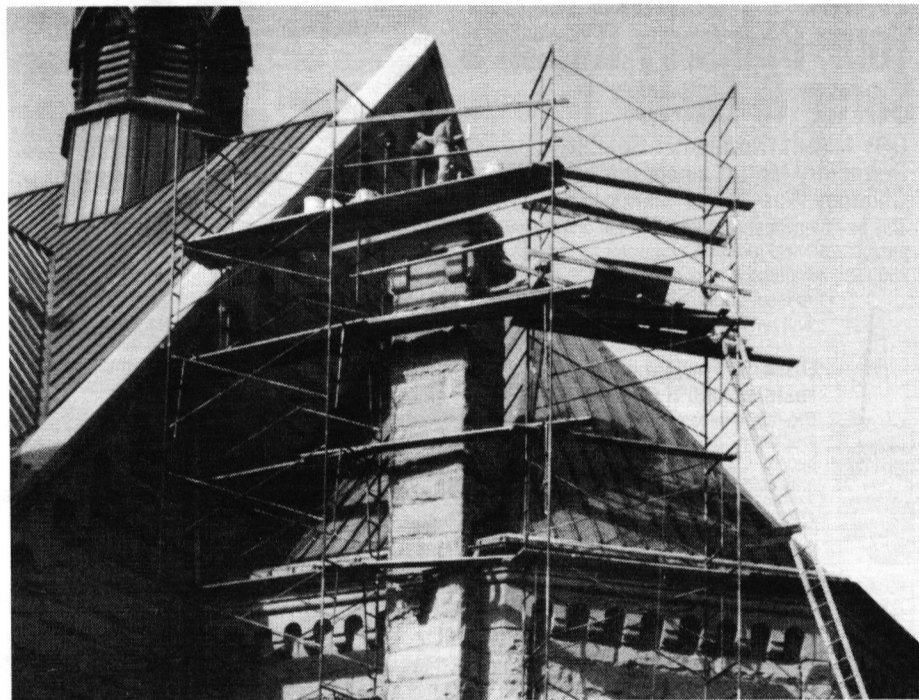

The **AHRENS POURED-IN-PLACE SYSTEM** workers on the top of the scaffold give one a sense of the large scale of this project, the Cathedral of the Madeleine in Salt Lake City, Utah. Write in No. 244

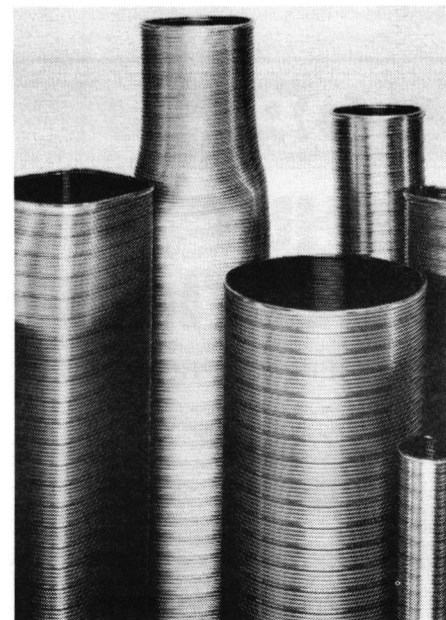

Ventinox HeavyFlex and HiFlex lining systems carry a lifetime warranty when used to vent woodburning appliances, pellet stoves, and woodburning fireplaces. The photograph shows the range of shapes available from **PROTECH SYSTEMS, INC.** Write in No. 206

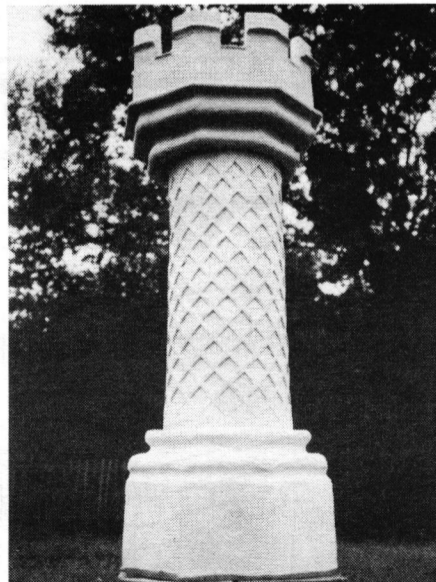

This handsome, crenelated ceramic chimney pot is manufactured by hand in Britain and is available from **NORTHERN ROOF TILES**.



NATIONAL SUPAFU SYSTEMS employee holding the Supaform which has been inflated to the proper flue size. Supafu material is then pumped in around the form. Write in No. 164

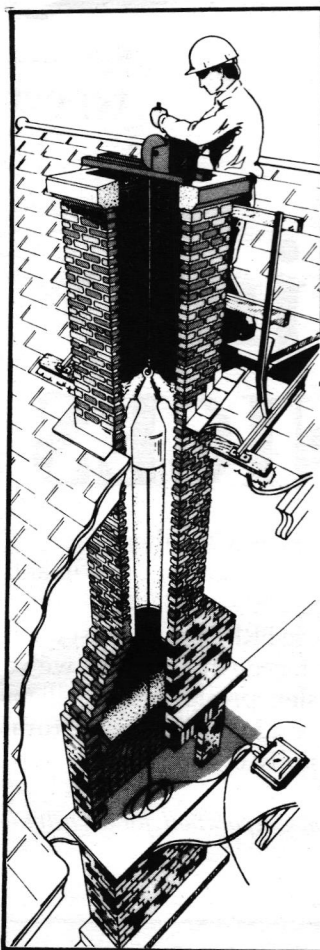

AHRENS[®]

**Relines/Restores
Masonry Chimneys**

**With The ONLY UL Listed, Two-Liner
Cast-In-Place Masonry Process**

- First liner insulates and strengthens
- Second liner seals and protects
- Both are immune to acids and moisture.
- No guess work. Mechanically applied.
- No exterior alterations
- No metal to corrode.
- Improves heating efficiency —

All for a fraction of the cost of rebuilding!

Dealership network nationwide.
Call or write for more information.

AHRENS chimney technique
2000 Industrial Ave.
Sioux Falls, SD 57104



1-800-843-4417

WRITE IN NO. 244

Build With Pieces of History



Now available in very limited quantities — authentic, decades-old, unused clinker brick. Due to changes in brick manufacture, when these are gone there won't be any more. Write for free literature or send \$10 for price list, color photos, and sample brick. *We do Custom Brick Engraving.*

The Brickyard
P.O. Box A
Harrisonville, MO 64701

(816) 887-3366
Ask for Kevin
Fax (816) 887-5757

WRITE IN NO. 396

**Fireplace & Chimney
RESTORATION**
Relining Systems

Supaflu

The Ultimate Flue Liner
For Your Masonry Chimney

Cast-In-Place Lining:

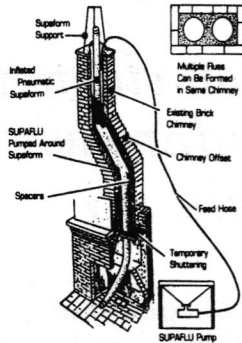

Stainless Steel
Lining

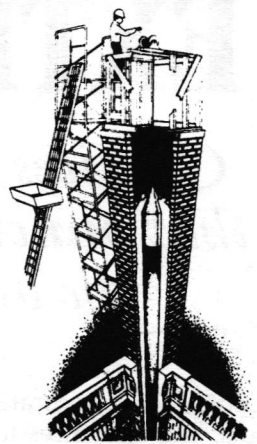
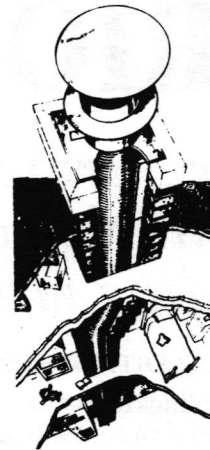

AHRENS chimney technique



MEMBER
NATIONAL
CHIMNEY
SWEEP
GUILD

- Rebuilding
- Repairs
- Chimney Cleaning
- Chimney Caps



Fully Insured
Serving Tri-State
Area Since 1960



CERTIFIED CHIMNEY
contractors inc.

201-361-1783

3122 Route 10 West • Denville, NJ 07834

WRITE IN NO. 428

Division 5 - METALS

WEATHER VANES AND

**COPPER TOP
CUPOLAS**

AMERICA'S
LARGEST and FINEST
SELECTION.

Choose from Thousands
Available or Have Us
Custom Craft Something
Special Just For You!

CALL OR WRITE FOR
OUR EXTENSIVE
FREE CATALOGUE

401-683-7974

Crosswinds Gallery

980-T EAST MAIN ROAD, PORTSMOUTH, RI 02871

WRITE IN NO. 263



Chestnut
NEW,
ANTIQUE &
CUSTOM DESIGN

WEATHERVANES

651 Route 6A, West Barnstable
Cape Cod, Massachusetts 02668
Lecture • Appraisals • Displays

Also: Weather vanes as Garden Ornaments
Illustrated Brochure, \$2.00 Refundable

WRITE IN NO. 659

WEATHERVANES

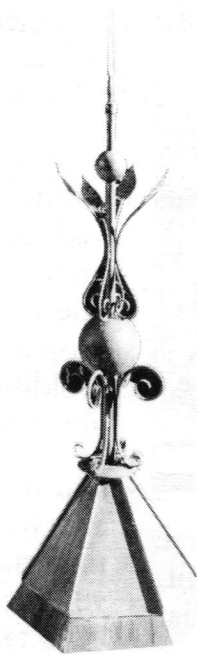

We offer
unique hand-
crafted
weather-
vanes, roof
spires,
lightning
rods,
and more...

FISCHER ARTWORKS
6530 S Windermere
Littleton CO 80120
(303) 798-4841
Catalog \$2⁰⁰

WRITE IN NO. 172

*Ornamental
Castings*



WRITE IN NO. 873

Crosses

Entryways

Sanctuary Items

Plaques

From design and mold-making
through casting and finishing,
no one is more qualified to
produce your custom-crafted
ornamental casting needs.
Trust in the craftsmen at
Lake Shore Industries.

Lake Shore Industries

1817 Poplar Street Box 59
Erie, PA 16512-0059
800 458-0463 (Outside PA)
814 456-4277 (In PA)
814 453-4293 (FAX)

On the outside, looking into EXTERIOR BUILDING CORNICES

Cornices are a transition element that punctuate the boundary where the building meets the sky.

BY JUDITH SIEGEL LIEF

Cornices have decorated buildings for centuries — their organic shapes, undercuts, and references to history and mythology distinguish one facade from another. There are literally hundreds of stock "mix-and-match" designs and many companies, nationwide, that will custom replicate, design, and fabricate.

The *SourceList* that follows was created from the 87 manufacturers (and installers) of exterior building cornices the Editors surveyed. We pared down the list to 24 companies that we determined would be of greatest interest to our audience of design professionals.

But how to select the right fabricator for the job? And what material would be most suitable? Cornice materials include: Metal, wood, terra cotta, stone, marble, and, more recently, a whole array of composites such as GFRC and FRP.

Because stone, metal, and terra cotta installations have been used for so long, one should be able to predict the performance of those materials — and their anchorings — fairly readily. FRP, although in regular use in construction

for over 25 years, is a relatively new material. However, as with other materials, the performance and quality of the final installation depends on the skill and integrity of the fabricator — and judicious specifying and supplier selection.

To help specifiers determine whether or not to use FRP, and to assist them in differentiating between a well-executed job and a facade that will fail, we've asked two veterans of the field — William Kreysler, president of William Kreysler & Associates and Charles Wittman, president of Architectural Fiberglass Corp. — to set down criteria for successfully evaluating FRP suppliers.

The Editors wish to thank Ed Axel, president of Edon Corporation, for his helpful contributions to this piece.

Instant Access to Product Literature for Exterior Cornices

If your office qualified to receive the 1993 TRADITIONAL BUILDING CATALOG, you'll find prefilled product literature there for the following suppliers of Building Cornices:

- Architectural Fiberglass Corp. • Edon Corp.
- MFG — Molded Fiber Glass • PlastrGlas • W.F. Norman Corp.

SPECIFYING FRP FOR EXTERIOR CORNICES

BY CHARLES WITTMAN
President, Architectural Fiberglass Corp.

Originally developed in the early 1940's for aircraft products and then used extensively in the boating industry, Fiberglass Reinforced Plastic (FRP) has seen construction uses ranging from strictly decorative statuary and bas relief panels to highly structural columns and trusses. Both for engineering and aesthetic reasons, exterior cornice work has become one of the most popular FRP building applications.

Fiberglass can replicate the appearance of other materials, combine many elements into single, lightweight, easily handled structural units, and do all this with a durable, permanently colored, no maintenance, molded-in surface finish. The polyester "Gel Coat" surface material is specially formulated to be UV stable and can be custom matched to virtually any color.

The high strength-to-weight ratio, the structural contributions of its geometry, and the inherent mechanical strength of a properly made laminate allow for simplified attachment details and, in many cases, avoid the need for expensive support structures. With a weight of approximately 1-1/2 lb. per sq.ft. of surface area (for a 3/16 in. thickness), the size of FRP units is only limited by handling considerations in the shop and at the job site.

Surface finishes, which can vary from

high polish gloss to low luster matte to extreme combing and textures, are a function of the type and finish of the production mold. Deep textures, undercuts, and field replications are usually made from flexible molds (silicone, latex, or urethane), which are limited in both production life and shape retention. Matte and glossy finishes, crisp details, large parts, and long production runs are normally produced in rigid fiberglass molds.



The ability to create and maintain these molds and the attention to details, fit, and dimension, are a major differentiation from one molder/fabricator to another. Saving money on tooling is usually a painfully false economy.

One way to minimize tooling costs is to explore the use of standard, stock, or pre-existing molds in lieu of custom moldmaking (unless the building has "Landmark" status requiring field-made molds). Since some fabricators may specialize in either custom replication or stock replacement projects, this could be an important factor in the

choice of vendor.

Stock cornice molds are available in numerous sizes and profiles and are often close enough in shape to the original cornices to be accepted for use in landmark restoration projects.

Inquire after the nature and extent of on-site and field services: Does the molder make site molds, conduct field measurements, provide engineering and hands-on installation supervision, or perform his own installation?

Assuming that all the fabricators are bidding on a job with well-drawn plans and complete, correct specifications, price quotation differences will exist due to interpretation of specs, use of proper grade and quality of material, molding shop efficiency, and clever engineering of tooling and products.

The bottom line in the selection of FRP as the most appropriate cornice material and the subsequent choice of vendor should be the "installed cost." This takes into account: Tooling up, production, shipping and handling, coordination, attachment details, installation, and long term maintenance. When compared to other possible exterior cornice materials, FRP provides an attractive and cost-effective option. ♦

■ Charles Wittman is a member of The Composites Fabricators Association. For more information on Architectural Fiberglass Corp., consult the *SourceList* on page 16.

SELECTING AN FRP FABRICATOR

There's a wide range of capabilities among FRP fabricators. Here are some tips on finding the right balance between price and quality.

BY WILLIAM KREYSLER
President, William Kreysler Associates

FRP is an often maligned material, due, in large part, to an incredible variety in quality. Its unique properties of extremely high strength, light weight, and durability can be a tremendous advantage in the hands of a competent, well-informed architect or contractor. Proper cost benefit analysis should include both installation charges and structural support requirements. Those who are concerned primarily with low initial cost will surely be able to find a fabricator willing to make a product of little value.

FRP fabrication is a competitive business. It is frequently true that a higher quotation represents higher quality or added value. The buyer's job is to determine what level of quality is required and to ensure that the supplier has understood the bid documents and can comply with them.

I. REFERENCES

Architectural restoration is a very specialized field. Anyone specifying FRP replicas should require bidders to demonstrate successful completion of similar projects with references, photos, examples of shop drawings, and samples. It's also useful to find out about a manufacturer's track record (i.e. how long have they been in business?).

II. BIDS

Evaluating a bid for FRP products is complex. Make certain you know (1) the manufacturer has in-house quality assurance; (2) the quote includes engineering; (3) what materials are used; (4) the welders are certified; (5) the replicated pieces will be exactly the shape of the original and not modified or simplified; and (6) the fabricator will allow for construction tolerances and thermal movement of adjacent materials. Many specifications do not address these issues, or the buyer doesn't check and follow up on them. Often, a higher price means higher quality. The real question is, how *much* quality is required?

III. SPECIFICATIONS

Are the specifications accurate and well crafted? (Very few of the dozens we have seen are.) Do they reflect the local code requirements regarding flammability? The Composites Fabricators Association publishes a specification guide. (For information, contact: Missy Hendrickson, 1735 N. Lynn St. #950, Arlington, VA 22209

(703) 524-3332.) Sometimes FRP fabricators have their own specifications. Care should be taken to have the specifications reviewed to assure fairness and accuracy. It is not a bad idea to have the bidders review and comment on the specs prior to bidding.

IV. SHOP DRAWINGS

It's wise to ask for an example of a fabricator's shop drawings when selecting bidders. A standard for shop drawings should be established that requires plans, elevations, sections, joint details, and erection procedures. Shop drawings are a strong indication of the fabricator's experience and expertise.

V. MOLDMAKING

Will the molds accurately replicate the original while providing proper flange and edge conditions for connection and waterproofing? Using molds taken off the building to directly make the finished part is rarely adequate. After all, what you see on the original is not necessarily all there was to the piece. Normally, a mold taken off the actual original is only used to make a mock-up or plug. This plug is then added to and re-configured creating flanges and returns, and then the production mold is made. Will the molds retain their shape and not allow the FRP to warp or twist during cure? Like nearly all cast materials, FRP shrinks upon curing. Care must be taken to allow for this.

VI. SUBMITTALS

Do the samples look like the original? FRP can mimic an amazing array of materials. From gloss to dead-flat smooth to exposed aggregate, most finishes can be copied quite well in the hands of a skilled fabricator. Remember that allowances should be made for dirt and oxidation on the original. Even terra cotta does yellow somewhat, as will FRP finishes. Sometimes the best situation is one where a match occurs after 1 or 2 years of aging. Yellowing and chalking are predictable to some degree and often can be allowed for. The amount of color shift is heavily dependent on the color chosen.

VII. PRODUCTION

Are the specifications being adhered to during production? If testing is required, is it being done? Is the work progressing according to schedule? Does the mock-up look like the sample? Will the fabricator allow tours during production? This business is about hard work and attention to details. Secrecy should be grounds for

suspicion.

VIII. ENGINEERING

This separates the field dramatically. If your project does *not* require an official engineer's calculation and stamp, you should clearly exclude it from the scope of work. Note that official stamps don't eliminate the need for smart, careful product and mold design. Also, there are lots of qualified fabricators who can produce excellent replica work without an in-house, licensed engineer. If engineering is required, don't expect that all bidders will be equipped to meet the requirements unless they can demonstrate they have done so in the past. Even then, engineering criteria may vary and the proposed engineer should be consulted if conditions are more demanding than a fabricator's previous work would indicate.

IX. DELIVERY

Does the fabricator confirm the delivery sequence prior to shipment? Are the products made with pick-points installed? Are they labeled? Storage and handling stresses can often exceed those which the product will see in use. Occasionally, the installation loads and stresses will govern the design.

X. INSTALLATION

Since most fabricators are manufacturers and not contractors, they need to (1) be responsive to the site condition; (2) communicate well with the installer; (3) (ideally) provide on-site personnel to assist during installation; (4) properly label all hardware and components; and (5) make sure parts fit.

As FRP properties become better understood and appreciated by the architectural community, we see a more professional approach to using it. We, and other firms, have lately been retained as consultants to help ensure that the end-product meets expectations. FRP is a sophisticated, well-proven product and has been used for over 45 years in far more demanding and rigorous situations than is required for architectural cladding. So, properly specified, designed, and manufactured, it can be a powerful tool for architects and builders. ♦

■ William Kreysler is a member of Composites Fabricators Association. For more information on William Kreysler Associates, consult the SourceList on page 16.

TRADITIONAL BUILDING's SourceList OF *CSI# 05700* EXTERIOR BUILDING CORNICES

COMPILED BY JUDITH SIEGEL LIEF

COMPANY	SPECIALTY	Literature	Max. Size	Materials	Installation Service
Alpha-One Fiberglass Exteriors 141 Rome St., Dept. TB Farmingdale, NY 11735 (516) 293-2611	Replications of existing exterior ornament in fiberglass, cast concrete, aluminum, or other materials as specified.	Free <i>Write in No. 486</i>	6 Ft. H.	Cast stone, cast concrete, plaster, cast aluminum, urethane or epoxy-filled resin casts	
Architectural Facades Unlimited 440 W. Julian, Ste. 240, Dept. TB San Jose, CA 95110 (408) 298-2758	Custom manufacture of interior and exterior precast architectural ornamentation. On-site, full service drawings, patterning, moldmaking, framing casting of columns, balustrades, cornices, niches, and more; commercial and residential.	Send \$15 for full spec book Free <i>Write in No. 147</i>	Any size	Standard cement, plaster, GFRC, various finishes	
Architectural Fiberglass, Corp. 1395 Marconi Blvd., Dept. TB Copiague, NY 11726 (516) 842-4772	FRP architectural ornamentation, including cornices, brackets, columns, friezes, rain gutters, and more; on-site moldmaking; custom shapes; shop-fabricated mitred corners; uv-resistant surface coatings; extensive experience with landmark projects; numerous standard cornice shapes.	Free <i>Write in No. 640</i>	8 Ft. H.	FRP, GFRC	✓
The Art Home Studios 64 Huron St., Dept. TB Brooklyn, NY 11222 (718) 383-0603	This shop specializes in landmark restorations from pattern and moldmaking to casting and sculpting architectural detail: Cornices, domes, molding, niches, balusters, and more.	Free <i>Write in No. 643</i>	Any size	FRP, GRG, GFRC, cast stone, cast marble, cast bronze	✓
Boston Valley Terra Cotta 6860 S. Abbott Rd., Dept. TB Orchard Park, NY 14127 (716) 649-7490	This company produces terra cotta replacement for in-kind restoration. They will work from drawings or photos, set up analyses for color and texture matching, make molds, and create final ornamentation.	Free <i>Write in No. 16</i>	5 Ft. H.	Terra cotta	
Campbellville Industries, Inc. P.O. Box 278, Dept. TB Campbellville, KY 42718 (800) 467-8135	This (primarily) steeple manufacturer also crafts cornices in aluminum — and other metals — in a variety of finishes.	Free <i>Write in No. 582</i>	12 Ft. H.	Aluminum, copper, lead-coated copper, galvanized, terne-coated stainless, etc.	
Edon Fiberglass 1160 Easton Rd., Dept. TB Horsham, PA 19044 (800) 523-2539 (215) 672-8050	This company designs, engineers, and manufactures FRP elements: Cupolas, steeples, domes, cornices, and other ornamentation. Ecclesiastical and landmark work a specialty.	Free <i>Write in No. 189</i>	Any size	FRP, FRG	✓
Felber Ornamental Plastering 110 Ardmore Ave., Dept. TB Ardmore, PA 19003 (215) 642-4710	Consultants, patternmakers, and fabricators of cornices (interior and exterior) and other architectural ornament in GRG. Historic restorations a specialty.	Send \$3 for catalog <i>Write in No. 289</i>	Any size	FRP, GFRC, Polymer-modified gypsum	
Fiberglass Masters Technologies, Inc. 1609-P Harmer St., Dept. TB Levittown, PA 19057 (215) 943-4567	This shop crafts FRP and GFRC ornament in any size or style; structural or non-structural; variety of finishes and colors; reproductions.	Free <i>Write in No. 471</i>	Any size	Modified gypsum, FRP, FRG, GFRC, cast stone	
Fibertech Corporation 250 S. Depot St., Dept. TB Pendleton, SC 29670 (803) 646-9990	FRP cornices range in size from 12 in. to 6 ft.; standard shapes; custom, commercial, and landmark work.	Free	6 Ft. H.	FRP	
Historical Arts & Casting, Inc. P.O. Box 35, Dept. TB West Jordan, UT 84084 (800) 225-1414 (801) 569-2400	Expert, finely crafted cast-metal ornamentation, including cornices, railings, store fronts, fences, lighting, and more; variety of finishes; custom work a specialty; will work from shop drawings.	Free <i>Write in No. 121</i>	Any size	Cast iron that can be finished to resemble iron, stone, marble, terra cotta, etc.	
LP Kent Corporation 4505 Park Ave., Dept. TB Bronx, NY 10457 (718) 365-4505	This sheet metal and roofing contractor has experience with landmark buildings and historic properties and specializes in slate and tile roofing and sheet metal fabrication of cornices and other architectural ornament.	Free <i>Write in No. 441</i>	Any size	Sheet metal	✓
William Kreysler & Assoc., Inc. P.O. Box 173, Dept. TB Penn Grove, CA 94951 (707) 765-1102	Designers, engineers, moldmakers, and fabricators of exterior ornamentation using FRP, GFRC, GRG, Polymer concrete, cast stone.	Free	12 Ft. H.	FRP, GFRC, polymer-modified gypsum, polymer concrete, cast stone	
David Kucera, Inc. 85 Wythe Ave., Dept. TB Brooklyn, NY 11211 (718) 387-6206	Expertise lies in the custom manufacture of precast (terra cotta, GFRC, FRG, cast stone, and gypsum) pieces with exact replication; landmark projects a specialty; on-site work; pattern work from drawings.	Free <i>Write in No. 459</i>	Any size	Cast stone, cast concrete, terra cotta, gypsum, FRP, FRG	
Merchant & Evans, Inc. 100 Connecticut Dr., Dept. TB Burlington, NJ 08016 (609) 387-3033	This company fabricates aluminum cornices (0.032 - 0.080 in.) in a variety of finishes; copper also available.	Free	4 Ft. H.	Sheet copper, aluminum	
Midland Engineering Co. 52369 U.S. 33 No., Dept. TB South Bend, IN 46637 (219) 272-0200	These fearless climbers have extensive experience in fabricating and installing exterior cornice, slate and tile roofing, and other work on historic commercial properties.	Free <i>Write in No. 742</i>	Any size	Sheet copper, galvanized, aluminum, sheet lead-coated copper, terne-coated stainless steel	✓
Hunt Miller 20521 Whites Ferry Rd., Dept. TB Poolesville, MD 20837 (301) 428-8061	This architectural sheet-metal contractor fabricates cornices, finials, conductor heads, and other ornamentation.	Free <i>Write in No. 929</i>	6 Ft. H.	Copper, lead-coated copper, zinc, stainless, galvanized	✓
Molded Fiber Glass 55 4th Ave., Dept. TB Union City, PA 16438 (814) 438-3841	This company specializes in FRP architectural elements; commercial projects; lay-up, spray-up, and in-house product design; engineering; fabrication.	Free <i>Write in No. 922</i>	Any size	Cast concrete, FRP	
Molloy & Associates, Inc. P.O. Box 515, Dept. TB Hutchins, TX 75141 (214) 225-6106	This company provides raw materials to the GFRC industry, makes on-site molds, and has access to the network of GFRC molding manufacturers.	Free <i>Write in No. 279</i>	10 Ft. H.	GFRC	✓
W.F. Norman Corp. P.O. Box 323, Dept. TB Nevada, MO 64772 (800) 641-4038	Largest fabricator of sheet-metal ornament in the U.S.; hundreds of stock designs of cornices, moldings, brackets and corbels, window and door caps, and lots more. Duplication of original pieces or will work from shop drawings.	Free <i>Write in No. 52</i>	6 Ft. H.	Sheet copper, galvanized; also stamped zinc and copper applied ornament	
Rocca Noto Studios, Inc. 10-06 38th Ave., Dept. TB Long Island City, NY 11101 (718) 937-1977	Architectural ornamentation in FRP. Moldmaking from drawings, templates, or on site; experience with Landmark projects.	Free <i>Write in No. 422</i>	Any size	FRP	
Seal Reinforced Fiberglass, Inc. 23 Bethpage Rd., Dept. TB Copiague, NY 11726 (516) 842-2230	This FRP molder and tooler fabricates building components and architectural elements; stock cornices and brackets; on-site molds.	Free <i>Write in No. 462</i>	6 Ft. H., 8 Ft. L. sections	FRP	✓
THR Products Corporation 58-15 49th Pl., Dept. TB Maspeth, NY 11378 (718) 326-4210	Custom fabrication and duplication of existing cornices and exterior trim; large stock collection.	Free	20 Ft. H. (single unit)	FRP, GFRC	✓
Vulcan Supply P.O. Box 100, Dept. TB Westford, VT 15494 (802) 878-4103	This custom fabricator will reproduce virtually any cornice profile; also custom finials, weathervanes, roof ornaments.	Free <i>Write in No. 721</i>	Any size	Galvanized, copper	

Campbellsville Industries

fabricators of
**CUSTOM and CLASSICAL
CORNICES**

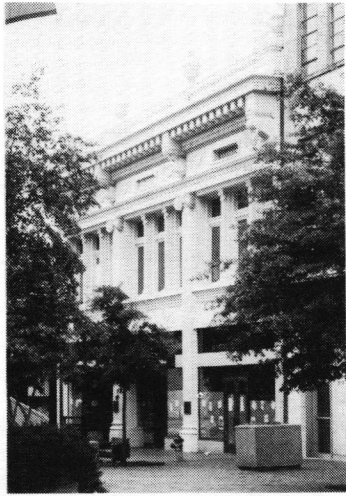

- custom fabrication
- delivery with our trucks
- variety of metals
- stock designs available
- historical reproductions
- baked on finishes

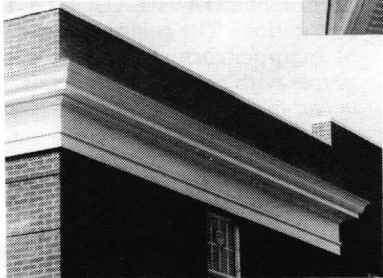

World's largest
fabricator of
**CUSTOM METAL
STEEPLES, CUPOLAS,
AND DOMES**

Other Campbellsville products

- CLOCKS • BALUSTRADES
- LOUVERS • WEATHERVANES
- TOWERS • DORMERS
- CARILLONS • COLUMNS

CALL AT ONCE: 800-467-8135 or Fax: 502-465-6839

CAMPBELLVILLE "The Steeple People" ...
INDUSTRIES, INC. plus

TAYLOR BOULEVARD, DEPT. TB, CAMPBELLVILLE, KY 42718

WRITE IN NO. 582

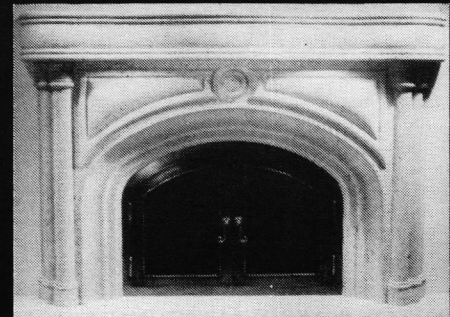
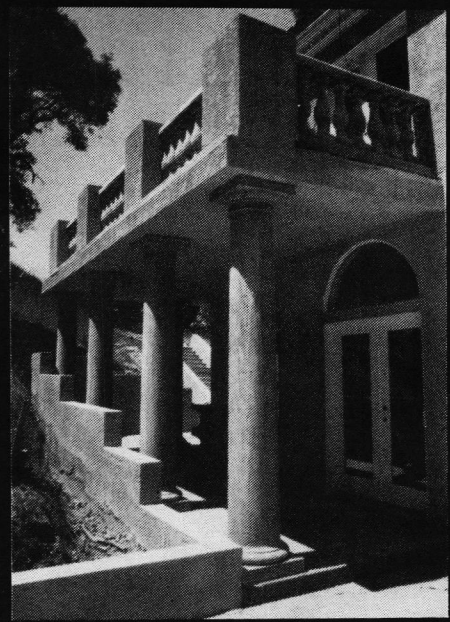
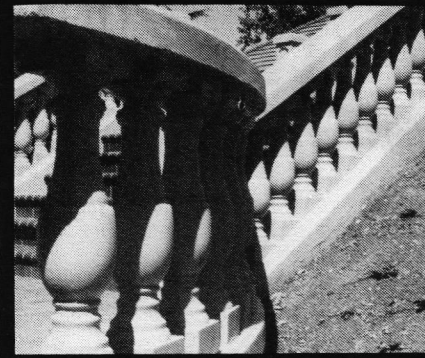

ARCHITECTURAL FACADES UNLIMITED

For those special details that set your properties apart from all others. We specialize in the design and production of columns, balustrades, pool coping, pavers, stairs treads, moldings, wallcaps, and mantels.

TO THE TRADE ONLY



ARCHITECTURAL FACADES UNLIMITED

440 West Julian, Suite 240
San Jose, California 95110
408 • 298 • 2758



WRITE IN NO. 147

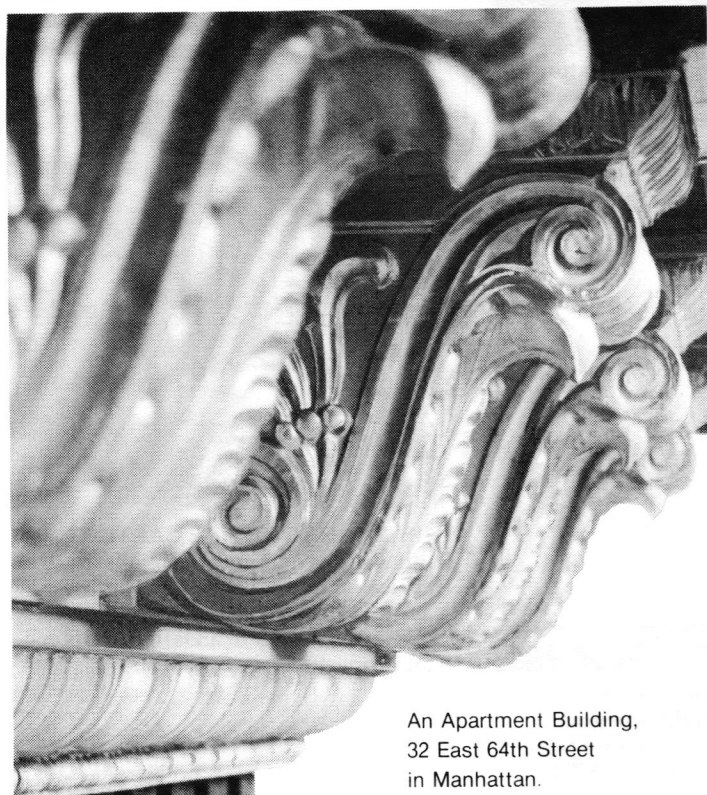

An Apartment Building,
32 East 64th Street
in Manhattan.

The Rectory of St. Mark's Church,
East 11th Street. (work in progress)

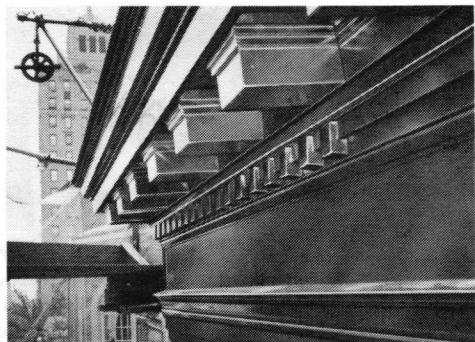

Cornices

and other ARCHITECTURAL & ROOFING COMPONENTS
of Sheet Metal...

L. P. Kent Corporation offers expert capability for sheet metal fabrication, roofing and installation with skills acquired in almost 50 years of experience in serving the construction industry.

Leaning towards the difficult or unusual project, we have acquired a sound reputation for our performance in restoration and new construction for many traditionally ornate landmark and contemporary structures such as Marymount School, the Fordham University Church, Ellis Island Restoration, St. Mark's Church Rectory, the Convent of the Sacred Heart, the Frick Collection, the St. George Hotel, the Metropolitan Museum of Art and many others.

As skilled craftsmen, we take pride in every one of our completed projects, maintaining the highest standards. As a successful organization, we can confidently guarantee performance and your long lasting satisfaction.

For a commitment to excellence, we are just a phone call away...



Ellis Island Restoration.

Lp Kent Corporation

SHEET METAL AND
ROOFING CONTRACTORS

4505 PARK AVENUE, BRONX, NY 10457 ■ Phone: (718) 365-4505
FAX: (718) 365-8033

WRITE IN NO. 441

EXTERIOR BUILDING CORNICES PORTFOLIO

For more information on these companies, consult the SourceList on page 16.

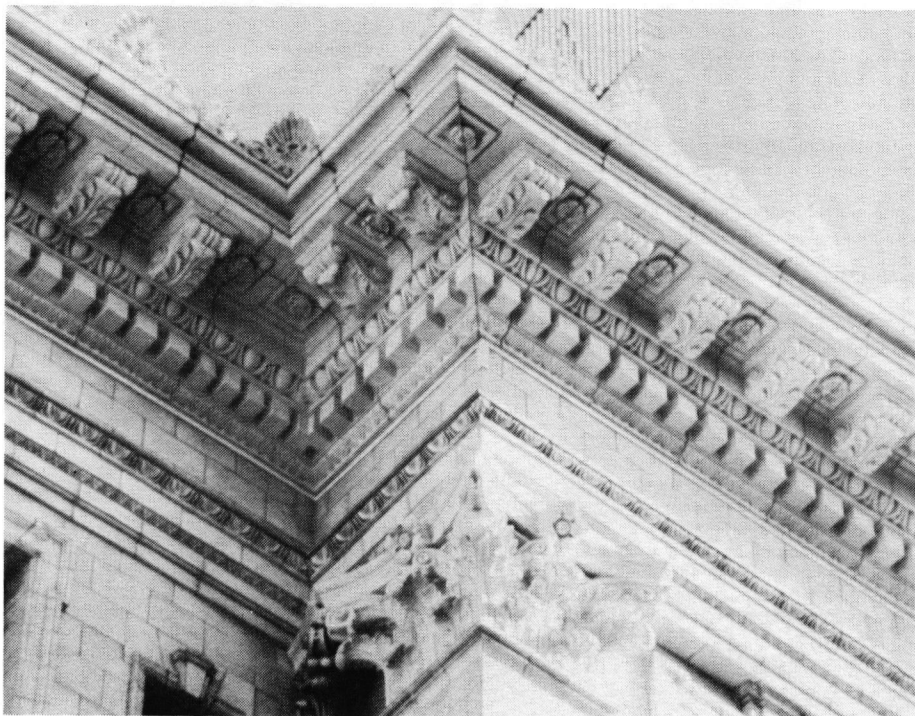

MOLLOY & ASSOCIATES, INC. provides the raw materials and service to the GFRG industry. This restoration shot of the Fairmont Hotel in San Francisco is an excellent example of the use of GFRG. *Write in No. 279*

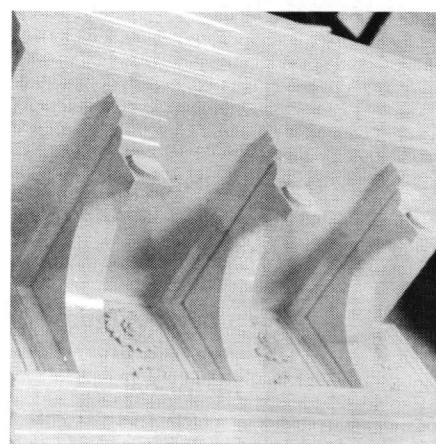

This custom bracketed cornice was cast in polymer by **FELBER ORNAMENTAL PLASTERING CORP.** *Write in No. 289*

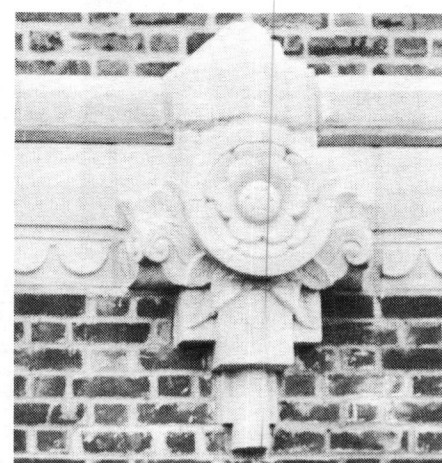

Section of a **DAVID KUCERA, INC.** restoration: The custom manufacture of an upper cornice using precast pieces with emphasis on detail. *Write in No. 459*



A metal cornice restored at a Manhattan upper east side residence by **L.P. KENT Corporation**, sheet metal and roofing contractors. *Write in No. 441*

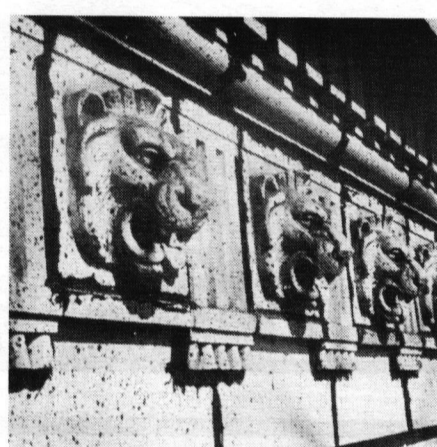

BOSTON VALLEY TERRA COTTA restored the Liberty Building, in Buffalo, with a polychrome terra cotta cornice — a typical like-kind custom project for this company. *Write in No. 16*

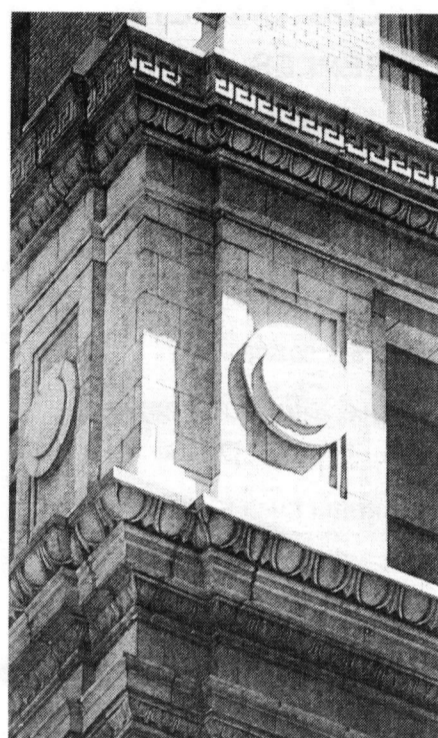

This 35,000 sq.ft. cornice restoration at the Equitable Building on lower Broadway, in New York City, is reputed to be the largest East Coast restoration using fiberglass (as a terra cotta replacement). **ROCCA NOTO SCULPTURE STUDIO** *Write in No. 422*

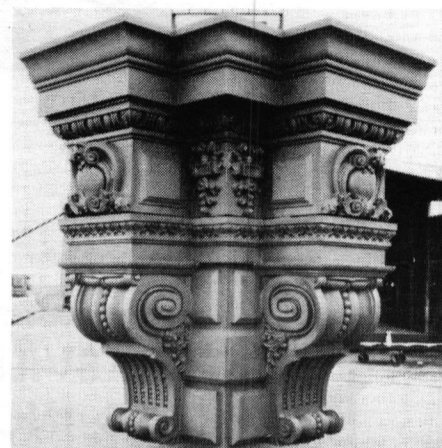

This FRP replica of a massive sandstone corner arch assembly, installed in San Francisco's James Flood Building, was fabricated by **WILLIAM KREYSLER & ASSOCIATES, INC.**

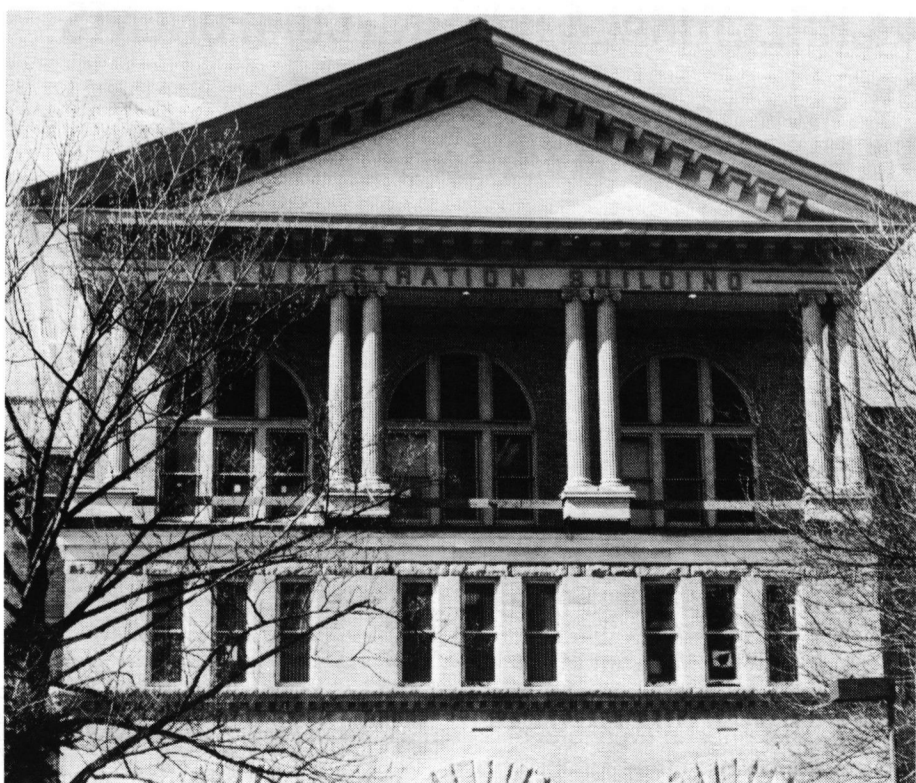

This in-progress restoration of a lead-coated copper cornice at Ball State University, in Muncie, Ind., was fabricated and installed by **MIDLAND ENGINEERING CO.** *Write in No. 742*

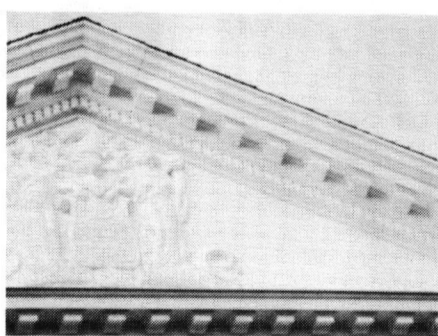

This aluminum cornice restoration, welded into a watertight, integral unit, was installed at Glassboro State College, in N.J., by **MERCHANT & EVANS, INC.**



HISTORICAL ARTS & CASTING, a high-end, custom cast-metal foundry fabricated this spectacular aluminum canopy (finished with a fluoropolymer coating) installed in a Dallas commercial property. *Write in No. 121*

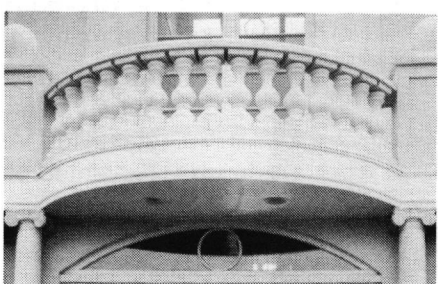

This newly constructed oceanfront home in N.J. features FRP balusters with top and bottom railings and columns with capitals and bases. **SEAL REINFORCED FIBERGLASS, INC.** *Write in No. 462*



"Stuart Style" FRP cornice, fabricated by **ARCHITECTURAL FIBERGLASS CORP.** and installed in downtown Manhattan. *Write in No. 640*



ORNAMENTAL SHEET METAL
by
Hunt Miller Company

On-site restoration of metal building cornices.
Pressed metal ceilings installed.
Finials, conductor heads and other ornaments reproduced.
Period sheet metal roofing.
Ask about our rolling sheet metal shop.
We install what others only sell.
Toll Free 1-800-787-1627
Metro Wash. 301-428-8061
Fax 301-349-2322

WRITE IN NO. 929

"CONCERNED CRAFTSMANSHIP"

ARCHITECTURAL FIBERGLASS CORP.

CORNICE SPECIALISTS • STANDARD & CUSTOM SHAPES



MOLDED FIBERGLASS FOR RESTORATION & NEW CONSTRUCTION

- EXACT DUPLICATIONS
- LANDMARK PRESERVATION
- CORROSION RESISTANT
- WATERPROOFING
- MOLDED-IN COLOR & FINISH
- FIRE RETARDANT - CLASS 1
- LIGHT WEIGHT
- COST EFFICIENT
- TERRA COTTA REPRODUCTION
- BALCONY REPLACEMENT
- BALUSTRADES & FASCIAS
- COLUMNS & PILASTERS

Call Or Write For Free Consultation
1395 Marconi Blvd., Copiague, N.Y. 11726 • 516-842-4772 • FAX 516-842-4790

WRITE IN NO. 640

VULCAN SUPPLY

Fabricators of custom finials, weathervanes, and roof ornaments.

Consultants for slate, tile, and copper roofing.

Suppliers of specialized roofing tools.

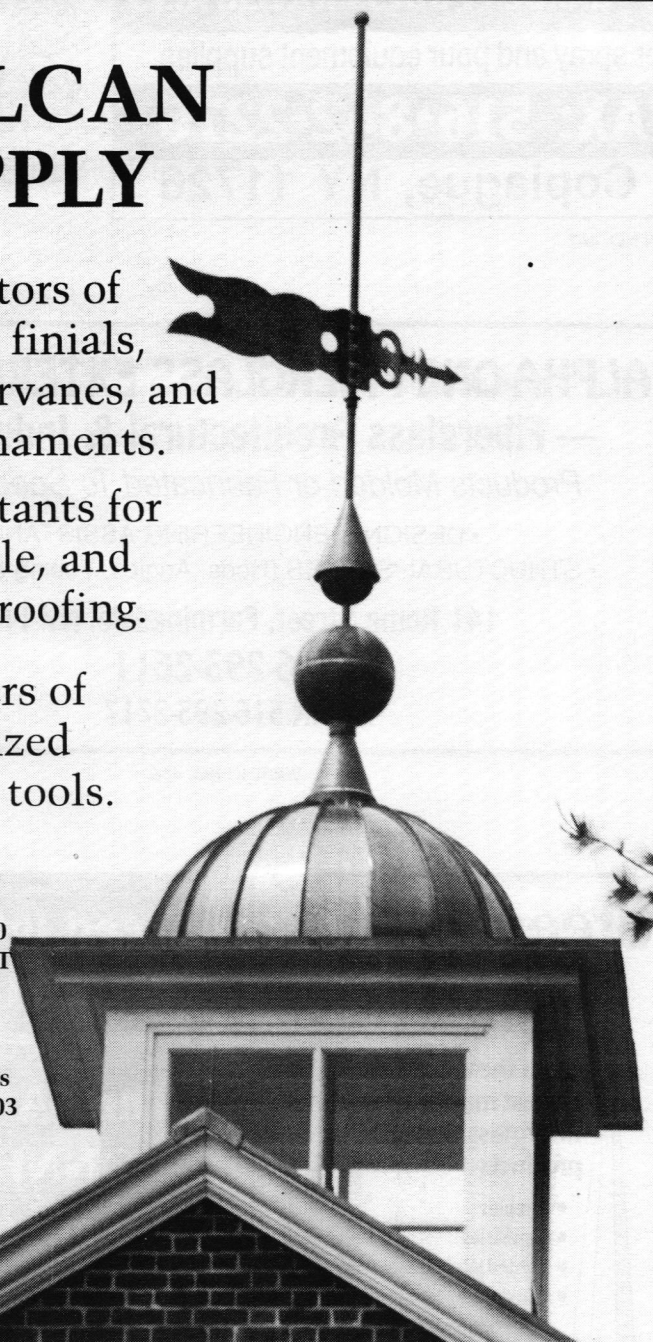

P.O. Box 100
Westford, VT 15494

Contact:
Larry Stearns
(802) 878-4103

WRITE IN NO. 721

Faster! Easier! More Versatile! Economical!

...Just Plain Better!

If your business is Architectural Restoration or New Decorative Pieces and your bottom line is what really counts, the professionals at *Smooth-On* can show you a better way to make molds.

Smooth-On molding compounds can be used on-site, and are readily pourable or "brushable" for painting onto vertical surfaces. Your mold will cure quickly to a durable rubber that will last and perform for you in a production mode - an exact copy of your original with flawless detail.



As Hyde Park Moldings in Long Island City, NY discovered that reproducing ornate 17' beams for the Jewish Museum Restoration Project in Manhattan was faster and easier using *Smooth-On's* PMC-121 molding compound. For details, call Eli at Hyde Park Moldings. Phone: (718) 706-0504.

It's easy to get started . . . Free working samples and technical help are available. Call us - We're easy to talk to.



1000 Valley Rd.
Gillette, New Jersey • 07933
Phone: (908) 647-5800
Fax: (908) 604-2224

Accept nothing less than *Smooth-On* molding compounds.
The difference is in the quality.

Smooth-On . . . your mold making partner™

WRITE IN NO. 65

ROCCA NOTO SCULPTURE STUDIO, INC.

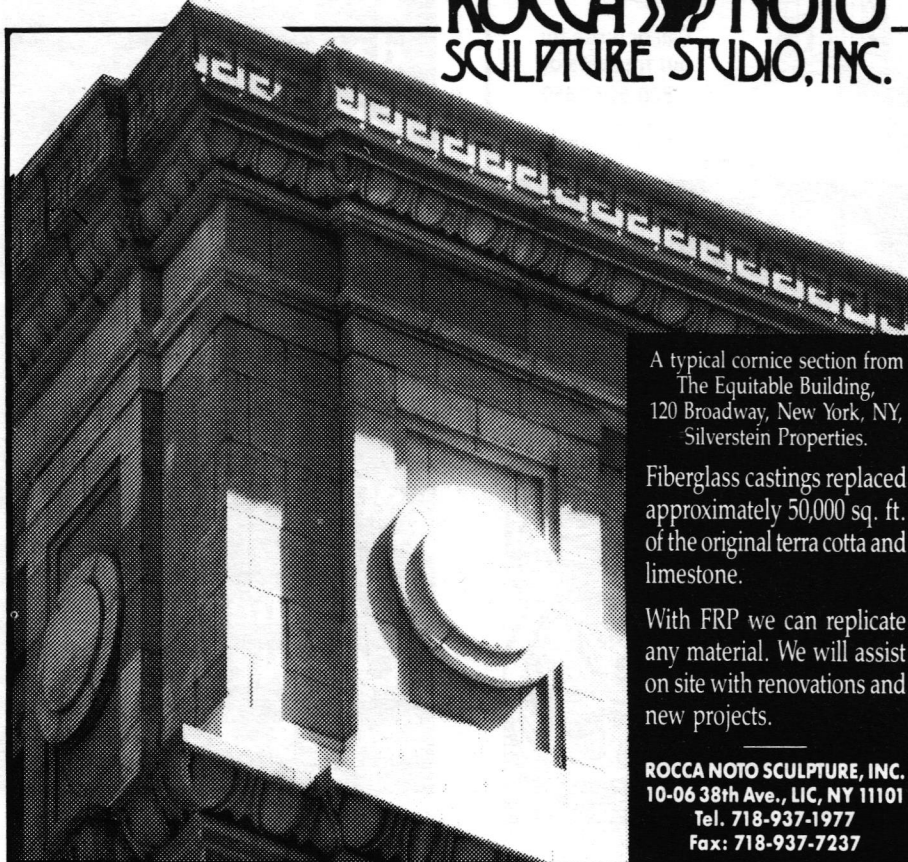

A typical cornice section from The Equitable Building, 120 Broadway, New York, NY, Silverstein Properties.

Fiberglass castings replaced approximately 50,000 sq. ft. of the original terra cotta and limestone.

With FRP we can replicate any material. We will assist on site with renovations and new projects.

ROCCA NOTO SCULPTURE, INC.
10-06 38th Ave., LIC, NY 11101
Tel. 718-937-1977
Fax: 718-937-7237

WRITE IN NO. 422

The Highest Roofing Skills

- Slate • Tile • Sheet Metal •
- Masonry Restoration
- Experienced With Major Historic Landmarks
- Since 1922 • Nationwide Service

(219) 272-0200



52369 U.S. 33 North • P.O. Box 1019 • South Bend, IN 46624



WRITE IN NO. 742

Architects Are No Longer Restricted By Traditional Materials

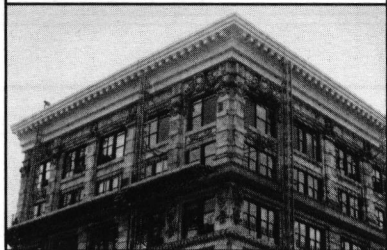
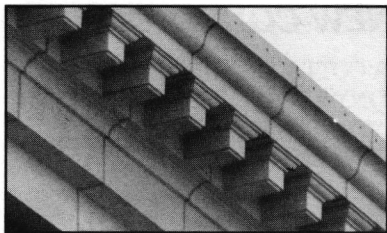

Aged copper cornice? Look again. FRP cornices replace existing copper at 250 Mercer in New York, NY.

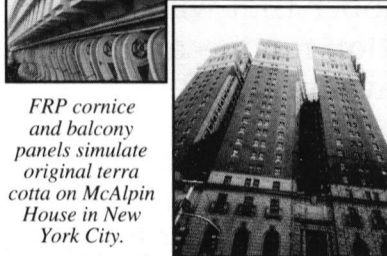
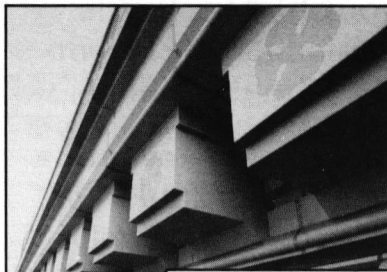

FRP cornice and balcony panels simulate original terra cotta on McAlpin House in New York City.

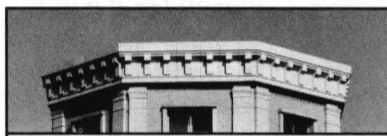

This architect chose FRP cornice over cast stone on the East 87th Street Apartments in New York City.

Why compromise your design when composites give you more control and choices. Traditional architectural materials rely on the vanishing skills of wood carvers, stone masons, & metal craftsmen. Fiber Glass Reinforced Plastic (FRP) is the architects' choice over wood, stone, metal, marble, terra-cotta and reinforced concrete because its strong, lightweight, maintenance free, & allows for greater design flexibility.

Your next project can also benefit from these products along with these services:

- Design
- Engineering
- Drawings
- Budget Estimates
- Planning Aid
- Product Manufacturing
- Field Support

Call us Toll Free today & discover creative freedom & lasting beauty designed for the life of your building.

MFG Dial 800-CALL-MFG

Molded Fiber Glass/Union City
55 Fourth Avenue, Union City, PA 16438
800-458-0863 (814) 438-3841
FAX 814-438-2284

Molded Fiber Glass Companies/West
9400 Holly Road, Adelanto, CA 92301
800-824-3389 in CA 619-246-4042
FAX 619-246-5500

WRITE IN NO. 922

Supplying the ultimate in reinforced fiberglass know how, engineering, and manufacturing services.



SEAL REINFORCED FIBERGLASS, INC.
Est. 1963

CUSTOM MOLDING OF EVERY TYPE. ARCHITECTURAL RESTORATION

- Brackets
- Cornices
- Railings
- Balusters
- Columns
- Pilasters
- Terra cotta reproductions

THEATRICAL PROPS • PLANTERS • GARDEN POOLS • WATERFALLS

Complete line of hand-held polyester spray and pour equipment supplies.

516-842-2230 - FAX: 516-842-2276

23 Bethpage Rd. Copiague, NY 11726

WRITE IN NO. 462



G F R C RESTORE.

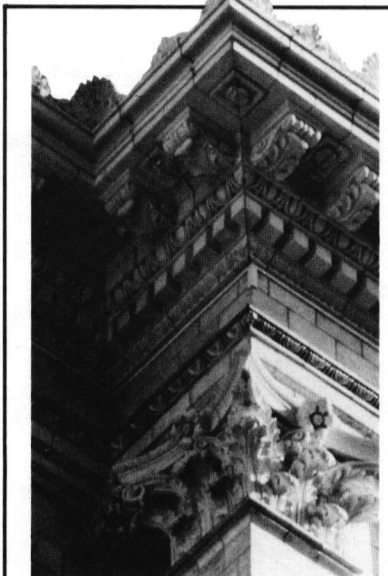

Glass Fiber Reinforced Concrete (GFRP) is ideal for building rehabilitation or retrofit projects. Its light weight minimizes the load added to the existing structure.

• **Design Flexibility** - in texture, pattern and surface finish allows it to blend with various construction materials.

• **Craftsmanship** - Exact replicas of original ornamental work from landmark and other historic buildings can be produced with complete accuracy.

For a list of qualified GFRP manufacturers call the only company that provides the complete GFRP package.

YOUR RESOURCE FOR GFRP TECHNOLOGY



P.O. BOX 515
HUTCHINS, TEXAS 75141
(214) 225-6106
Distributors of NEG AR Glassfiber

WRITE IN NO. 279

ALPHA-ONE FIBERGLASS EXTERIORS, INC.

— Fiberglass Architectural & Industrial —
Products Molded or Fabricated To Specifications

- DESIGN & ENGINEERING ASSISTANCE
- STRUCTURAL SHAPES (Rods, Angles, Tubing & Flat Sheet)

141 Rome Street, Farmingdale, NY 11735

516-293-2611

FAX 516-293-2717

WRITE IN NO. 486

Steeple & Baptistries

From the world's largest manufacturer of fiberglass church products

- Steeples
- Baptistries
- Lighted Wall Crosses
- Krinklglas® Windows
- Baptistry Heaters



Call or write for our free catalog

1-800-527-1459
P.O. Box 1340
Henderson, TX 75653-1340

FIBERGLASS SPECIALTIES INCORPORATED

WRITE IN NO. 731



Need Information RIGHT AWAY?

The FAX CONNECTION

Form at the back of this issue is the fastest way to get product data and catalogs. Just fill the form out ONCE and then FAX it to as many suppliers as are appropriate.

Use the FAX CONNECTION on pg. 76.

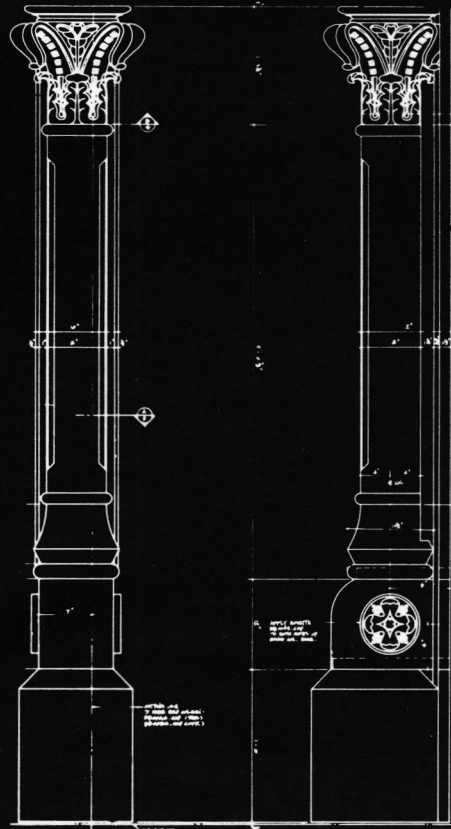

HISTORY. TRADITION. CRAFTSMANSHIP.

During the mid-nineteenth century, the ironworks foundry of Daniel Doncaster & Sons of Albany, New York offered a wide variety of classical column features, including iron fronts with plain, fluted, paneled, and round columns, and elaborate capitals and bases.

Today, the craftsmen at Historical Arts and Casting of Salt Lake City specialize in the restoration and replication of cast metal ornamentation, including beautifully ornate capitals and bases, designed and manufactured with the same care and attention as our predecessors.

For additional information, please write or call:

HISTORICAL ARTS AND CASTING, INC.

P.O. Box 35
WEST JORDAN, UTAH 84084
(801) 569-2400
TOLL FREE (800) 225-1414
FAX (801) 569-2493



WRITE IN NO. 121



**SCULPTURE
STUDIOS, CO.**

Architectural **PLASTER**



Historical restoration of St. Peter's Church, Hartford, CT

Architectural **FIBERGLASS**



FRP used at exterior of Weston House, N.Y.C.

Architectural **CAST-STONE**



The Art Home Studios, Inc. offers complete architectural sculpture service. Our proficient craftsmen are capable of replicating any architectural detail for historic renovations and restorations. Also, we are able to recreate new architectural design, utilizing GRG, FRP, GFRC, Cast-stone, Cast-marble and cold-cast metal from architect's drawings.

Send us a sketch, photo, blueprint, or anything showing your concept for price estimate, or call us for assistance on site.

718-383-0603
FAX: 718-389-7578
64 HURON STREET
BROOKLYN, NY 11222

WRITE IN NO. 643



DAVID KUCERA, INC.

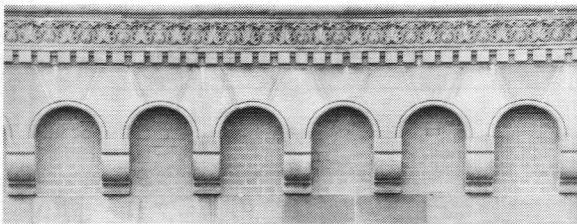

ARCHITECTURAL SCULPTURE

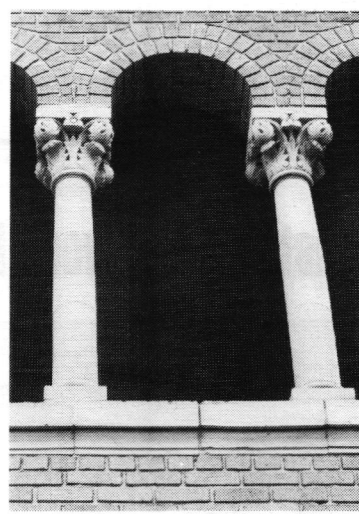

Replication of:
Terra Cotta • Limestone
Brownstone • Cast Iron
Ornamental Metal
Cast Stone • Marble
Specialty Materials

Architectural ornament for restoration and new construction • Pattern work from original drawings • On-site molds and surveys to recreate original elements • Color matching • Creation of models and production molds

Castings In All Materials
Precast Concrete • Cast Stone
GFRC • Fiberglass Laminates
Fiber-Reinforced Plaster or Gypsum
Polymer-Reinforced Concrete

85 WYTHE AVENUE, BROOKLYN, NY 11211 (718) 387-6206 FAX (718) 384-8919

WRITE IN NO. 459

It's Really
BIG!

RESTORATION '93
Exhibition & Conference

*The largest preservation
and restoration event
in North America.*

December 6-8, 1993
Hynes Convention Center
Boston, Massachusetts
See page 71 for details

• BOSTON VALLEY TERRA COTTA • Architectural Terra Cotta for Restoration and New Building



Our highly experienced ceramic engineers & technical R&D staff specialize in:

- Matching original pieces
- Moldmaking & ram pressing
- Restorations or new installations
- Custom-made roof tile

Write for our literature and client list.

95 Madison Ave., NYC. Architect: Walter Melvin

BOSTON VALLEY TERRA COTTA
6860 S. Abbott Road, Orchard Park, NY 14127
716-649-7490

WRITE IN NO. 16

Division 6
WOOD & PLASTICS

special report
WOOD MOLDINGS

WOOD MOLDINGS: Gratuitous Embellishment or Essential Interior Definition?

*Moldings, properly placed in an open, interior space
reconcile abstract geometry and human scale.*

For the definitive treatise on moldings, see Donald Rattner's *magnum opus* on page 4 of this issue. Once one fully understands the importance of moldings and proportion in an

interior space, the *SourceList* that follows should be a helpful guide for selecting appropriate architectural millwork manufacturers and suppliers.

The Editors surveyed 184 molding manufacturers, and

from those companies that responded, selected the 38 that provide the best cross section of carved, embossed, straight-run, curved, radius, metal-covered, or flexible wood and wood lookalike elements. ♦

Instant Access to Product Literature for Wood Moldings

If your office qualified to receive the 1993 TRADITIONAL BUILDING CATALOG, you'll find prefilled product literature there for the following suppliers of wood moldings and wood substitutes:

- Architectural Components
- Center Lumber
- Crowning Touch
- Cumberland Woodcraft
- Custom Decorative Moldings
- Driwood Moldings
- Enkeboll Designs
- Executive Woodsmiths
- Mohamed Wood Turning
- Mountain Lumber Co.
- J.E. Smith Co.
- Vintage Wood Works
- White River Hardwoods
- Ron Wiener — Woodcarver
- Woodstone

Custom Woodwork has never been this easy!

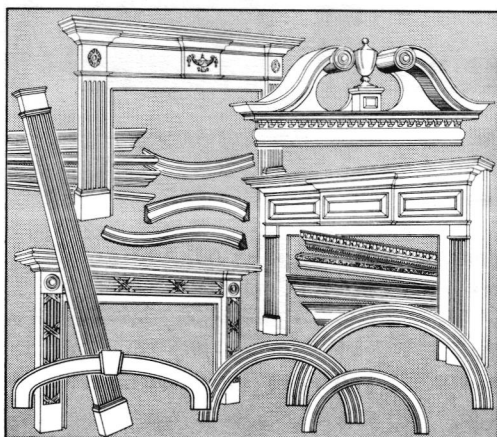

Executive Woodsmiths will craft a wide variety of mantels, door pediments, and architectural features to your size and style requirements. We also produce mouldings of grand proportions in our patterns or yours, in straights or curves.

Now there's an easy way to make your designs come to life. Please call us to discuss your next project.

Brochures available upon request.

Executive Woodsmiths, Inc.
215-V Foster Ave.
Charlotte, NC 28203
(704) 527-9090

WRITE IN NO. 932

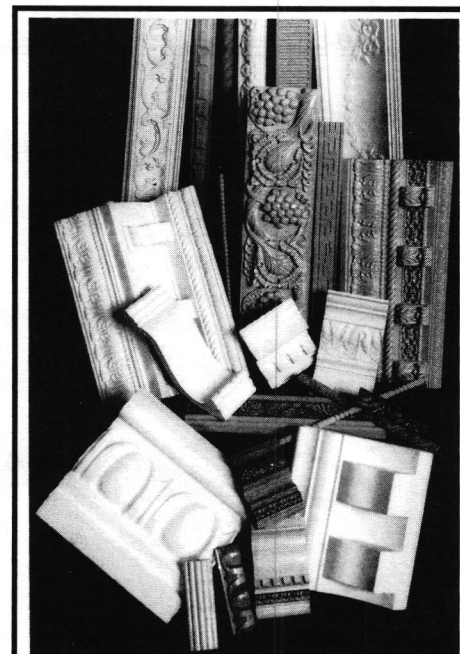

The ONE source for ALL your Architectural embellishments.
Moldings in wood, urethane, resin, plaster, metal, E.P.S., or stone.

3223 Canton Street CAT. (800) 662-1221
Dallas, TX • 75226 \$5.00 FAX (214) 748-7149

CAS CLASSIC ARCHITECTURAL SPECIALTIES

WRITE IN NO. 904

MOLDER / PLANNER FOR STRAIGHT, CIRCULAR, ELLIPTICAL* MOLDINGS (Casings, Crowns, Picture Frames, Raised Panels)

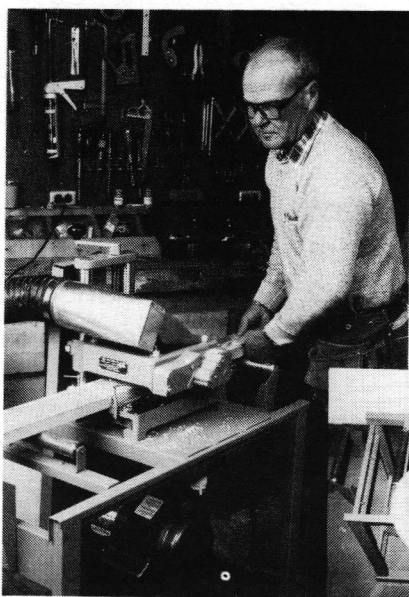

Our W•7 S Model Offers Versatility and Durability

FEATURES:

- Duplication of historic profiles up to 3/4 in. deep
 - Solid cast-iron base & head
- Molder-to-Planer in less than 2 minutes
 - Portable - on site or in the shop
- 7,000 rpm/two-knife system produces 78 cuts per in.
 - 100 standard knives • Custom knives
- Five-Year Warranty • Fully American Made!

*Elliptical jig required

EJ92 Elliptical Jig allows radii as small as 7 in.



WILLIAMS & HUSSEY MACHINE CO. INC.

P.O. BOX 1149 • WILTON NH • 03086
(603) 654-6828 • FAX (603) 654-5446

WRITE IN NO. 498

For hard-to-find

- MOULDINGS
- RAILINGS
- BALUSTERS
- WAINSCOTING
- COLUMNS
- CUSTOM MILLWORK and TURNINGS

M.L. CONDON COMPANY Inc.
White Plains, NY
Stormville, NY

Phone or FAX your requirements for a **FAST price quote!**
Just send us a tracing or sketch of the profile

Phone 914/946-4111
FAX 914/946-3779

or send \$2 for our 32-page color catalog to:
256 Ferris Ave
White Plains NY 10603

We Ship Nationwide!

AFRORMOSIA
ANIGRE
ASH
AVODIRE
BALSA
BASSWOOD
BEECH
BIRCH
BOXWOOD
BUBINGA
BUTTERNUT
CEDAR
CHERRY
CHESTNUT
COCOBOLO
CYPRESS
EBONIES
ELM • FIR
GONCALO ALVES
GREENHEART
HICKORY
HOLLY
IMBUYA
IPE • KOA
LACEWOOD
LAUREL
LIGNUM VITAE
LIMBA • LOCUST
MAHOGANIES
MANSONIA
MAPLES
OAKS
OSAGE
PADDAK
PALDAO
PEARWOOD
PERNAMBUCO
PINES • POPLAR
PURPLEHEART
RAMIN
REDWOOD
ROSEWOODS
SAPELE
SATINWOODS
SHEDUA
SITKA SPRUCE
SYCAMORES
TEAK • TULIP
WALNUTS
WENGE
ZEBRA
ZIRICOTE

WRITE IN NO. 401

Authenticity, Craftsmanship, and the beauty of natural wood

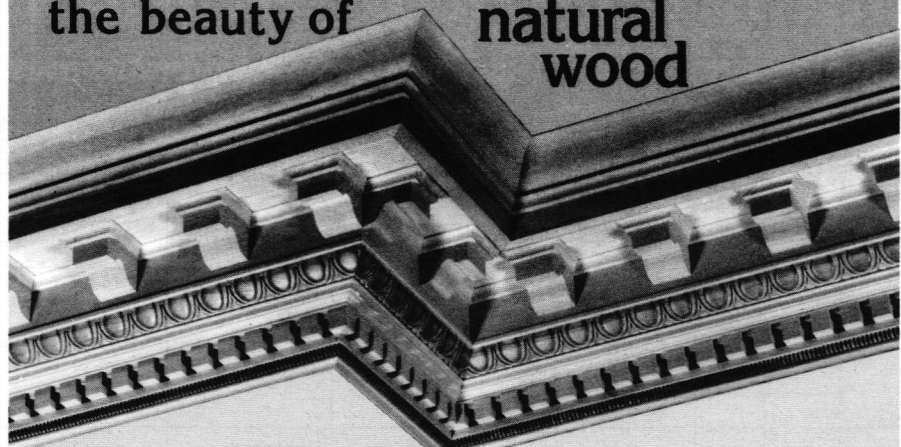

- Design services & consultation
- Custom designed & crafted interiors
- Embossed wood mouldings — straight or curved
- Doors • Mantels • Gun cases
- Available in all species of wood
- Raised paneling • Circular stairs
- Custom cabinetry • Entryways
- Supervision from design to installation

CATALOG AVAILABLE — \$5



AMERICAN CUSTOM MILLWORK, INC.

3904 NEWTON ROAD • P.O. BOX 3608
ALBANY, GA 31706
(912) 888-3303 • (912) 888-6848 • FAX (912) 888-9245
U.S.A. — WORLDWIDE

WRITE IN NO. 678

White River ORNAMENTALS

We offer a concept... not just a product

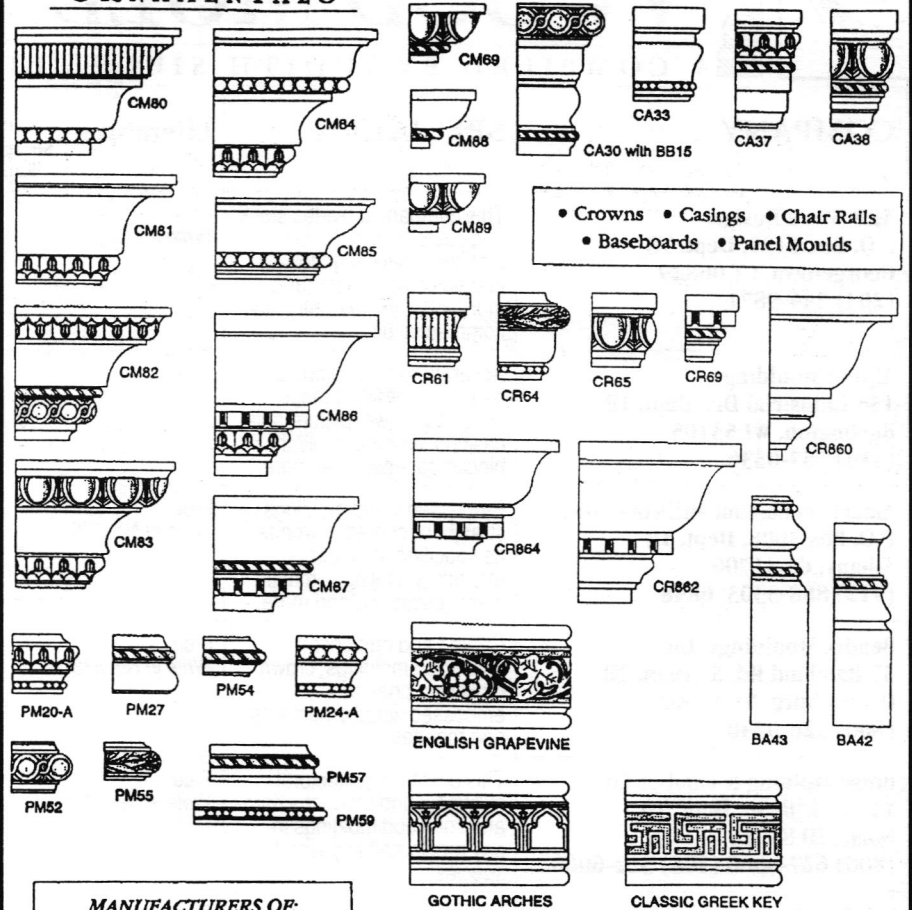

- Crowns • Casings • Chair Rails
- Baseboards • Panel Moulds

MANUFACTURERS OF:
Ornamentally Embossed
Hardwood Mouldings,
Rail & Stile Doors, Entry Units,
Curved & Radius Mouldings

A COMPLETE LINE OF
ARCHITECTURAL MOULDINGS
May be painted, stained, glazed, pickled

1197 Happy Hollow Road • Fayetteville, AR 72701
1 (800) 558-0119 • Phone (501) 442-6986 • Fax (501) 444-0406

WRITE IN NO. 232

You Design The Molding... We'll Make The Knives!

Shaper/Molder Knives

Knives made for all woodworking machinery

- 3 Day Shipping •

Counselor Profiles

- Mastercard
- Visa
- Amex



637 Wyckoff Ave.
#272
Wyckoff, NJ
07481-1442

1-800-635-6285

FAX: 201-848-9867

WRITE IN NO. 430

Make your designs, decor and products COME ALIVE!

A flexible material that handles like wood

FLEXMOULDING and "Superflex Moulding"

Polyester mouldings offer all the advantages of wood—at a fraction of the cost. Beautify and enhance your projects with mouldings, spot decorations, simulated wood carvings etc.

FLEX • MOULDING can be:

- Nailed
- Glued
- Painted
- Stained
- Drilled
- Sawn
- Gilded
- Antiqued

Flex Moulding can accurately copy and reproduce from any sample piece. Flex Moulding can be made fire retardant or fire proof.

Write or call for 38 page catalog:
(201) 487-8080 • Fax: (201) 487-6637

Flex Moulding, Inc.

16 East Lafayette St., Hackensack, N.J. 07601

WRITE IN NO. 490

Decorative Mouldings



- Genuine American Hardwood Mouldings
- Panel & Trim • Casing • Chair Rail • Crowns
 - Baseboards • Period and Custom Designs
 - Custom Milling • Custom & Stock Turnings
 - Corner Blocks & Plinth Blocks
 - Custom & Stock Doors

Hundreds of standard styles available in poplar for immediate delivery from stock in lengths to 16 feet, stained or unstained.

Also available in: basswood, cherry, maple, mahogany, pine, red oak, walnut, and fire retardant basswood. Custom mouldings to your specs or to match sample.

For Catalog and Price List send \$2.00 for postage and handling to:

Empire Moulding Co. Inc.

721-733 Monroe Street, Hoboken, New Jersey 07030
Tel: 201-659-3222 FAX: 201-659-2259

WRITE IN NO. 616

The choice of shape is yours.



T. J. Carr is a manufacturer of quality custom mouldings with an emphasis on service and the assurance of accuracy and elegance of the finished product.

- Custom and standard wood trim.
- 1/8" thick veneers to 9" wide crowns.
- Casing, Base, Crown, Flooring, Paneling, Siding mouldings.
- Specializing in short runs.

Call or write for free brochure.



375 Middlesex Tpke, Old Saybrook CT 06475 • (203) 388-0434

WRITE IN NO. 489

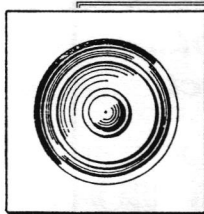

TRADITIONAL BUILDING's WOOD MOLDINGS SourceList

CSI# 06400

* COMPILED BY JUDITH SIEGEL LIEF

COMPANY	SPECIALTY	Literature	TYPE OF MOLDINGS								MATERIALS	Custom Matching	% Custom
			Straight Run	Embossed	Carved	Dentil	Fluted/Reeded	Curved/Radius	Flexible	Other			
A&B Wood Design P.O. Box 1199, Dept. TB Georgetown, CT 06829 (203) 544-9871	This company provides stock and custom manufacture of moldings, paneling, newels and balusters, doors, and more for both residential and commercial use.	Free Write in No. 222	*		*	*	*	*			Exotics	*	50%
Alpine Moulding 155 Industrial Dr., Dept. TB Burlington, WI 53105 (414) 767-0336	Accurate reproductions of hard and softwood moldings including crown, picture rails, casings, chair rails, plinth blocks, rosettes, and more.	None	*			*	*			Interior and exterior	Hardwoods, softwoods, or as specified	*	99%
American Custom Millwork, Inc. P.O. Box 3608, Dept. TB Albany, GA 31706 (912) 888-3303, 6848	Embossed wood moldings — straight or curved in woods as specified. Also doors, mantels, paneling, circular stairs, cabinetry, and more.	Free Write in No. 678	*	*		*		*			As specified	*	80%
Bendix Mouldings, Inc. 37 Ramland Rd. S., Dept. TB Orangeburg, NY 10962 (800) 526-0240	Carved and embossed hardwood moldings; crown moldings, chair rail; embossed wood ornaments and rosettes.	Free Write in No. 578		*	*	*	*				Hardwoods, softwoods		25%
Boise Molding & Lumber Co. 116 E. 44th St., Dept. TB Boise, ID 83714 (800) 627-6066 (208) 322-6066	This custom architectural millwork shop produces hard- and softwood moldings in any profile and any wood species.	Free Write in No. 317	*	*	*	*	*			Wood windows, doors, rosettes, plinth blocks, more	As specified	*	25%
T.J. Carr Company P.O. Box 399, Dept. TB Old Saybrook, CT 06475 (203) 388-0434	Custom manufacturing capabilities include casing, base, crown, flooring, paneling, siding; short runs a specialty.	Free Write in No. 489	*					*			Hardwood, softwood	*	90%
Center Lumber Co. 85 Fulton St., Dept. TB Paterson, NJ 07509 (201) 742-8300	Over 1,400 knives for straight runs and over 90 knives for curves; custom grinding facility to match any profile.	Free Write in No. 680	*			*	*	*	*		Hardwoods	*	99%
Chesapeake Molding & Millwork Co. P.O. Box 762, Dept. TB Millersville, MD 21108 (410) 987-3404	Manufacturers of high-end architectural moldings, including reproduction, curved, mantels, and rosettes.	Free Write in No. 880	*			*	*	*			Hardwoods, softwoods	*	45%
Classic Architectural Specialties 3223 Canton St., Dept. TB Dallas, TX 75226 (800) 662-1221	This company supplies moldings and appliques in both wood and synthetics.	Free Write in No. 904		*	*	*	*		*		Hardwoods, softwoods, polyester resin, polyurethane, polystyrene		65%
ML Condon Co., Inc. 256 Ferris Ave., Dept. TB White Plains, NY 10603 (914) 946-4111	This large-capacity shop stocks wood in species from A-Z and will create any profile to spec: Moldings, railings, balusters, wainscoting, columns, and more.	Free Write in No. 401	*			*	*	*		Turnings, doors, lots more	Hardwoods, softwoods, as specified	*	80%
Counselor Profiles, Inc. 637 Wyckoff Ave. #272, Dept. TB Wyckoff, NJ 07481 (800) 635-6285 (201) 848-8811	Custom profile knives for woodworking machinery: Shapers, molders, molder/planers, and rosette tool holders. Fax drawings.	Free Write in No. 430								Knives for wood-working machinery	NA	*	99%
Dimension Lumber 517 Stagg St., Dept. TB Brooklyn, NY 11237 (718) 497-1680	This wood molding manufacturer has the capability to create any molding in any wood species; ships nationwide.	Free	*					*			Hardwoods, softwoods, as specified	*	80%
Driwood Moulding Co., Inc. P.O. Box 1729, Dept. TB Florence, SC 29503 (803) 669-2478	Over 400 moldings in stock; capability of manufacturing any profile in any wood species.	Free	*	*	*	*	*	*		Custom profiles	Hardwoods, softwoods	*	10%
Empire Molding Co., Inc. 721-733 Monroe St., Dept. TB Hoboken, NJ 07030 (201) 659-3222	This company stocks hundreds of styles of moldings, chair rails, crowns, baseboards, turnings, doors, and more; lengths to 16 ft.; finishes.	Free Write in No. 616	*	*		*	*			Corner and plinth blocks, turnings, doors	Hardwoods, basswood, cherry, maple, mahogany, pine, red oak, walnut	*	100%
Executive Woodsmiths 215 Foster Ave., Dept. TB Charlotte, NC 28203 (704) 527-9090	Full line of custom architectural woodwork, including unique, classically proportioned moldings in straights or curves; stock or custom; also deep embossings.	Free Write in No. 932	*	*		*	*	*			Hardwoods, softwoods	*	50%
Flex Moulding, Inc. 16 E. Lafayette St., Dept. TB Hackensack, NJ 07601 (201) 487-8080	This company offers flexible and rigid moldings, spot decorations, simulated wood carvings for furniture, and more.	Free Write in No. 490	*	*	*	*	*	*	*	Custom reproductions	Polymers, polyester	*	20%
Forester Moulding & Lumber, Inc. 152 Hamilton St., Dept. TB Leominster, MA 01453 (508) 840-3100	This molding manufacturer provides stock and custom millwork, including handrails, bases and crowns, random-width flooring, rosettes and plinth blocks, and more.	Free Write in No. 98	*			*	*				Hardwoods	*	40%
Hendricks Woodworking Box 227-1B, Dept. TB Kempton, PA 19529 (215) 756-6187	Distinctive circular moldings to spec for interior and exterior applications; stock and matched profiles.	Free						*			As specified	*	100%

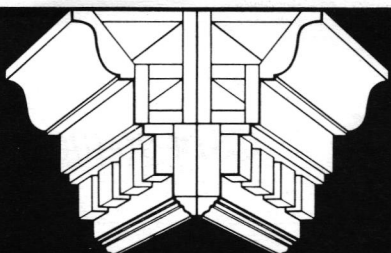

CENTER LUMBER CO.

Custom Millwork
Mouldings A Specialty
Custom Grinding Facilities
1,400 Existing Profiles
Doors • Windows • Bar Tops
Curved Mouldings
Fine Hardwoods

AWI, NHLA

85 Fulton Street, Box 2242
Paterson, New Jersey 07509
(201) 742-8300 • Fax (201) 742-8303

WRITE IN NO. 680



Solid hardwood architectural

Ornamental® mouldings

Since our founding in 1926, our reputation for high quality and attention to detail is *unsurpassed.*

Isn't it nice to know there's a company out there with qualities that reflect your own renovation and restoration values?

- | | | |
|-------------------|------------|---------------|
| Cornice Mouldings | Chair Rail | Baseboards |
| Corner Blocks | Corbels | Plinth Blocks |
| Pilaster Capitals | Pediments | Door Casings |

Ask for Ornamental® Mouldings at your local millwork or home products store, or call 800-779-1135 for the dealer nearest you.

WRITE IN NO. 706

AUTHENTIC ARCHITECTURAL REPRODUCTIONS

- superior quality
- large array of products
- 100% stable, thus guaranteed not to shrink or expand
- price competitive
- easily installed
- class A fire rated products available
- drilled and dowelled joints
- overnight delivery by request



nmc Decoration, inc.
a company of the nmc group

“ World's Largest Manufacturer of Advanced Polymer Crown Mouldings, Ceiling Medallions, and Niches ”

501 nmc drive
Zebulon, NC 27597
tel 800-345-7279
fax 919-269-6005

Inquire about fire rated products

Free color catalogue

Dealers/Distributors Inquiries welcome

WRITE IN NO. 477



SPECIALISTS IN HISTORIC PRESERVATION RESTORATION CONSULTATIONS



GENERAL & DECORATIVE CONTRACTING
REPRODUCTION OF ARCHITECTURAL ELEMENTS AND FURNITURE.
COMMERCIAL, RESIDENTIAL & MUSEUMS

35 HILLSIDE AVENUE
MONSEY, NY 10952
(800) 378-4778 (914) 425-0650
FAX (914) 425-1842

STRASSER & ASSOCIATES, INC.
Architectural Restoration • Period Interiors

WRITE IN NO. 365

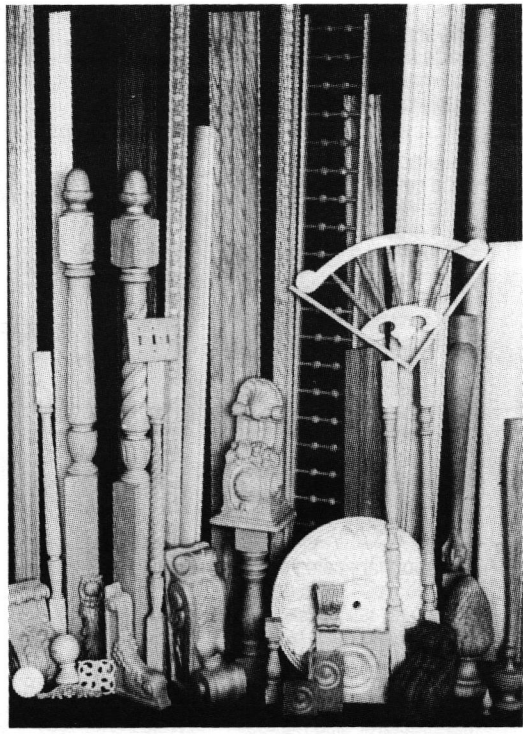
House of Moulding
Largest Selection for 41 years

- Hardwood & Softwood Moulding in Stock
- Corbels
- Wood Turnings
- Decorative Plaques
- Fireplace Mantle Mouldings
- Send Check for \$7.00 to receive a Full Catalog.

House of Moulding
Dept. TB
15202 Oxnard St.
Van Nuys, CA 91411

Phone: In California: (800) 675-1952
Outside CA: (800) 327-4186
Fax: (818) 994-7848

WRITE IN NO. 230

This Catalog should be in your files

Over 150 illustrations of decorative wood mouldings and ornaments for every architectural need. Write for your copy today.

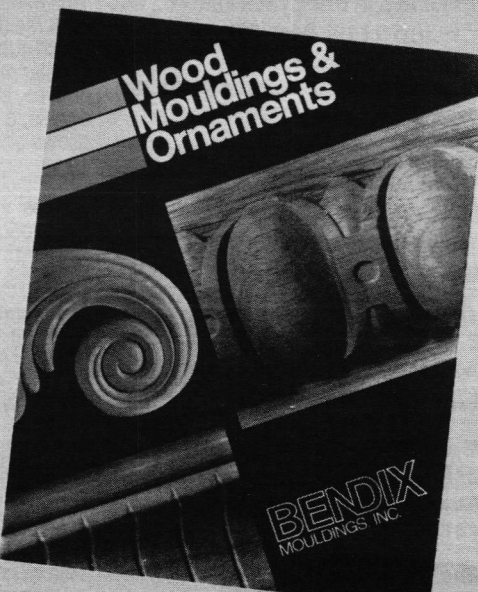

BENDIX MOULDINGS, INC.

37 Ramland Road South, Orangeburg, New York 10962
Tel: (914) 365-1111 • 1-800-526-0240 • Fax: (914) 365-1218

WRITE IN NO. 578

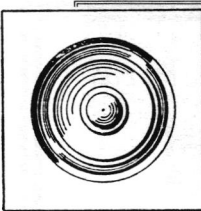

WOOD MOLDINGS SourceList

CSI# 06400

* COMPILED BY JUDITH SIEGEL LIEF

COMPANY	SPECIALTY	Literature	TYPE OF MOLDINGS								MATERIALS	Custom Matching	% Custom
			Straight Run	Embossed	Carved	Dentil	Fluted/Reeded	Curved/Radius	Flexible	Other			
House of Moulding 15202 Oxnard St., Dept. TB Van Nuys, CA 91411 Outside CA (800) 327-4186 In CA (800) 675-1952	Large selection of hardwood and softwood moldings; also corbels, decorative plaques, finials, ceiling medallions, mantels, and more.	Free Write in No. 230	*	*	*	*	*	*	*	*	Hardwoods, softwoods	*	40%
Macartney Classical Woodcarving 608 Spear Ave., Dept. TB Duluth, MN 55803 (218) 724-5307	All styles of carved moldings, carved doors, frames, and mantels.	Free Write in No. 460			*						Hardwoods, softwoods	*	100%
National Hardwood Flooring/Moulding 14959 Delano St., Dept. TB Van Nuys, CA 91411 (818) 988-9663 In CA (800) 848-5556	This company provides flooring, moldings, columns, staircases, mantels, and other tools and equipment. 4-1/2 million ft. of material stocked; custom milling.	Send \$15 for 450-pg. catalog Free flyer Write in No. 474	*	*	*	*	*	*	*	*	Hardwoods, softwoods, polymers	*	25%
NMC Decoration, Inc. 501 NMC Dr., Dept. TB Zebulon, NC 27597 (800) 345-7279	Manufacturers of high-density polymer moldings, medallions, and niches.	Free Write in No. 477	*	*	*	*	*	*	*	*	High-density polyurethane, polystyrene (fire retardant)	*	5%
Ornamental Mouldings 1907 Nuggett Rd., Dept. TB High Point, NC 27263 (919) 431-9120	Solid hardwood architectural moldings and accessories, including period moldings, custom designs, and exotic woods.	Free Write in No. 706		*	*	*	*	*	*	*	Hardwoods	*	5%
Outwater Plastics Industries 4 Passaic St., Dept. TB Wood Ridge, NJ 07075 (800) 631-8375	Extensive selection of polymer moldings, including ceiling medallions, chair rails, columns, and other molded ornament.	Free Write in No. 493	*			*	*	*	*	Columns	Polymer		5%
Powell Cabinet & Fixture 1300 Freeport Blvd., Dept. TB Sparks, NV 89431 (702) 359-4700	This shop can build any shape or radius to spec. It also makes molds and can supply cast members.	Free	*	*		*	*	*	*	Molds and cast members	Hardwoods, softwoods, GFRG	*	95%
Prime Wood Products, Inc. 4430 136th Ave., Dept. TB Holland, WI 49424 (616) 399-4700	Manufacturers of suspended wood ceiling systems in 2 styles; also other specialty wood products and architectural accoutrements.	Free Write in No. 494	*			*	*			Wood ceiling system	Oak, cherry, poplar	*	20%
South Shore Millwork 34 N. Worcester St., Dept. TB Norton, MA 02766 (508) 226-7419	Custom woodworking shop that specializes in custom doors, entries, moldings, and millwork; residential and commercial.	Free	*			*	*	*			Hardwoods, softwoods	*	100%
Style-Mark, Inc. 960 W. Barre Rd., Dept. TB Archbold, OH 43502 (419) 445-0116	High-density polyurethane millwork: Moldings, gable louvers, door entrance systems, pilasters, mantels, and pediments.	Free Write in No. 485	*	*	*	*	*	*	*	Moldings ranging from 8-12 ft. lengths	High-density polyurethane	*	20%
Sunrise Moulding & Frame 154 26th St., Dept. TB Brooklyn, NY 11232 (718) 499-1710	This shop fabricates metal-covered wood moldings in chrome, brass, copper, bronze, aluminum; polished, brushed; custom work.	Free	*			*					Hardwoods and softwoods covered in various metals	*	20%
Vermont Custom Doors & More, Inc. RD1, Box 1780, Dept. TB Fairfield, VT 05455 (802) 524-9682	This custom door manufacturer also makes moldings, tilt-and-turn patio doors and windows, and more.	Free Write in No. 458	*			*	*	*		Doors, windows	As specified	*	100%
White River Hardwoods, Inc. 1197 Happy Hollow Rd., Dept. TB Fayetteville, AR 72701 (800) 558-0119 (501) 442-6986	Over 200 molding profiles in poplar and red oak; also 80 embossed moldings, architectural millwork, curved and radius moldings, and more.	Free Write in No. 232	*	*		*	*	*			Poplar, red oak, or as specified	*	50%
Williams and Hussey Machine Co., Inc. P.O. Box 1149, Dept. TB Wilton, NH 03086 (800) 258-1380 (603) 654-6828	This company makes the W-S Molder and Planer, which cuts straight and circular moldings, casings, crowns, frames, and raised panels; a jig attachment allows elliptical cuts as well.	Free Write in No. 498								Molder/planer			NA
Windham Millwork, Inc. Box 1358, Dept. TB Windham, ME 04062 (207) 892-3238	Stock includes over 1,000 profiles; variety of hardwoods; custom knife grinding.	Send \$5 for catalog	*					*			Hardwoods	*	80%
The James Wood Company P.O. Box 3547, Dept. TB Williamsport, PA 17701 (717) 326-3662	Modular molding and paneling system consists of grooved moldings and decorative inserts for easy assembly and installation.	Free Send \$10 for sample kit	*	*		*	*	*	*	Pre-coped crown moldings	Hardwoods, poplar, soft maple, or as specified; prefinishing	*	5%
Wood-O-Rama 238 W. 108th St., Dept. TB New York, NY 10025 (212) 749-6438	This company distributes wood moldings from most of the major molding manufacturers.	Free Write in No. 754	*	*	*	*	*	*		Columns, medallions, more	Hardwoods, softwoods, polymers	*	10%
The Woodstone Company P.O. Box 223, Dept. TB Westminster, VT 05158 (802) 722-9217	This custom window shop manufactures muntin profiles to 7/8 in., with insulating glass with custom and stock moldings to match.	None	*					*			Hardwoods, softwoods	*	100%
Yuenger Wood Moulding, Inc. 5215 S. Keeler Ave., Dept. TB Chicago, IL 60632 (312) 735-7100	Hardwood moldings, embossings, and custom matching.	Free	*	*							Hardwoods	*	98%

Hardwoods? Easy!

Buy direct from
New England's
Moulding
Specialists

The Source
for Quality
Hardwoods

- Standard Mouldings
- Custom Mouldings
- Matched Mouldings
- Curved Mouldings
- Handrails
- Wall Paneling
- S4S and S2S
- Short Runs/Long Runs
- Random Width Flooring
- Strip Oak Flooring Stocked
- All Species Available
- Gluing and Cut-to-Length
- Rosettes and Plinth Blocks
- Sawmill-Direct Prices
- 1-800-649-9734 (MA only)

Call for a profile brochure and price list

Forester 152 Hamilton Street
Moulding & Lumber, Inc. Leominster, MA 01453
508-840-3100

WRITE IN NO. 98

NATIONAL HARDWOOD

WHOLESALE DISTRIBUTOR OF HARDWOOD FLOORING & MOULDING

Your Complete Source of
Flooring & Moulding,
at the best price
in town.

PAYING TOO MUCH???

PRODUCT SHOWN
NOT TO ACTUAL
SIZE

MANTELS

NO. 466

NO. 415

CRW-S x 5

CBL-TW2

CBL-GO2

ORAC DECOR

R-37

B-403

L-501

C-214

P-7020

P-3020

Wood Air

FLOORING

JEFFERSONIAN

HADDON HALL

HUDON

BORDEAUX

FOUNTAINBLEAU

AMA SOLID CTR

FLEX TRIM

BALUSTER

BLF-G03

BLF-P03

BLF-R03

NWL-FF3

NWL-TF3

NWL-AF5

BAR-GB1

VOL-FR1

TRD-AL1

MOULDING BASE

126

129

131

141

142

145

CASING

207

208

212

232

233

CROWN/CORNICE

260

263

262

CHAIR RAIL

232

PANEL MOULDING

427

424

14959 DELANO ST., VAN NUYS, CA 91401
(818) 988-9663 / TOLL FREE (800) 848-5556 FAX (818) 988-4995

WRITE IN NO. 474

MOULDING SPECIALISTS



We stock and distribute over 500
moulding patterns from all the
major moulding manufacturers in pine, oak,
poplar, mahogany, cherry, and polymer.

Curved, radius and special shapes, columns,
ceiling medallions, and much more.

Custom orders welcome.
Call us with your special needs.

WOOD-O-RAMA INC.

238 W. 108th Street New York, NY 10025
Phone 1-800-BIG-MOLDING

WRITE IN NO. 754

FREE NEW 1993 CATALOG

Style~Mark
INC.
**Formed
Millwork**
ARCHITECTURAL
ACCENTS™

- Over 900 items
- Won't Rot or Decay
- Low Maintenance

Arches • Brackets • Trim
Louvers • Window Heads
Moldings • Entryways
Millwork & More.

Style~Mark
INC.

960 W. Barre Rd., Archbold, Ohio 43502 • 800-446-3040

WRITE IN NO. 485

WOOD MOLDINGS PORTFOLIO

For more information on these companies, consult the SourceList on pages 24-26.

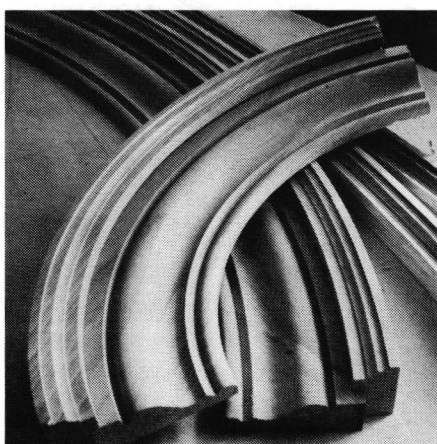

CENTER LUMBER's large stock of knives provides for a huge array of molding profiles. Shown here are two curved and two straight run moldings. Write in No. 680

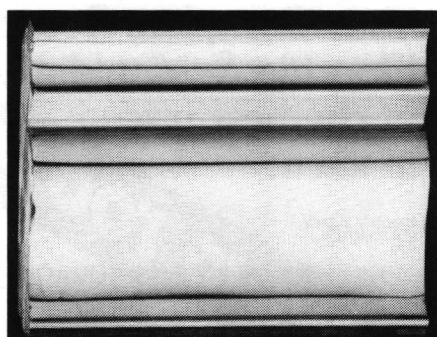

Style No. E-101BLB brass covered wood molding with a high-gloss polish from SUNRISE MOULDING & FRAME.

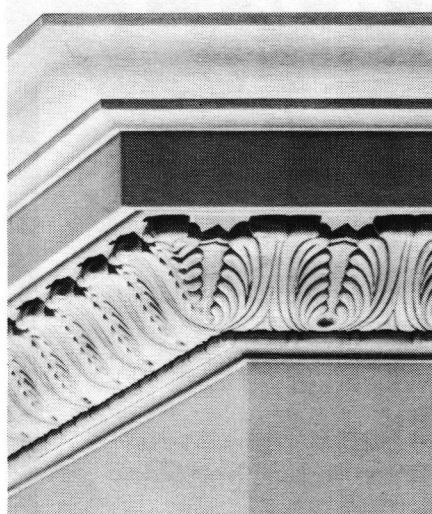

This embossed hardwood acanthus leaf assembly molding (#827) is manufactured by ORNAMENTAL MOULDINGS, INC. Write in No. 706

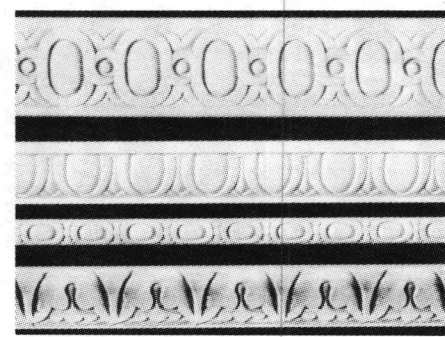

These embossed moldings are part of BENDIX MOULDINGS, INC.'s voluminous stock of embossed, stock, dentilled, and fluted hard and softwood moldings. Write in No. 578



The variety of traditional hardwood moldings (straight and curved), pilasters, crowns, sash, and more milled by WINDHAM MILLWORK, INC., are demonstrated in this interior setting.

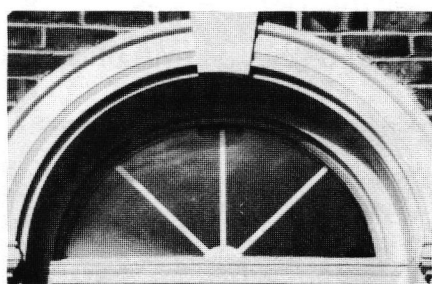

STYLE-MARK, INC.'s packages of high-density polyurethane molded elements are illustrated in this photo of decorative arch with end caps and keystone, door crosshead, and pilaster. Write in No. 485

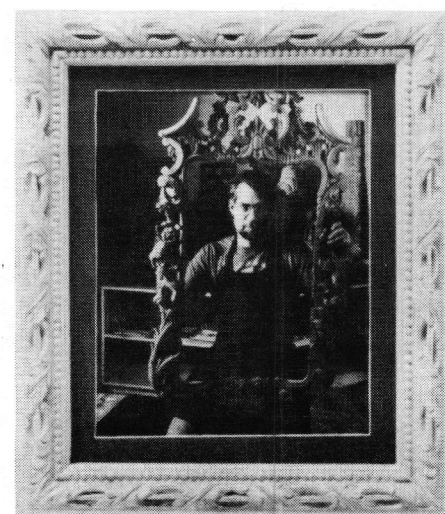

This "leaf and pin" design is a hand-carved molding from MACARTNEY CLASSICAL WOODCARVING. Write in No. 460

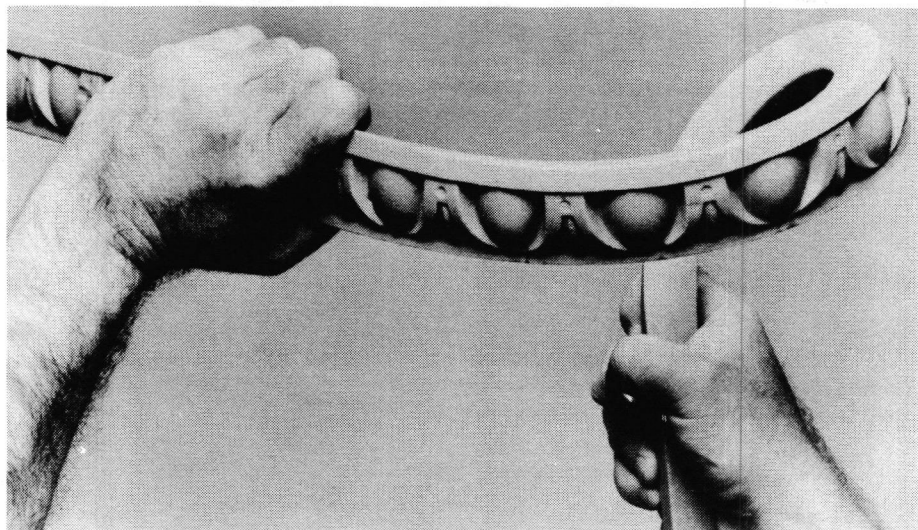

This egg-and-dart polyester molding is flexible in all dimensions. FLEX MOULDING, INC. Write in No. 490

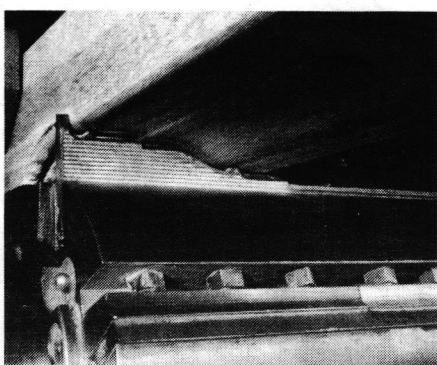

Custom cutting is a specialty of M.L. CONDON CO. and complements their 35,000 sq.ft. warehouse of 43 wood species and 40 stock moldings. Write in No. 401

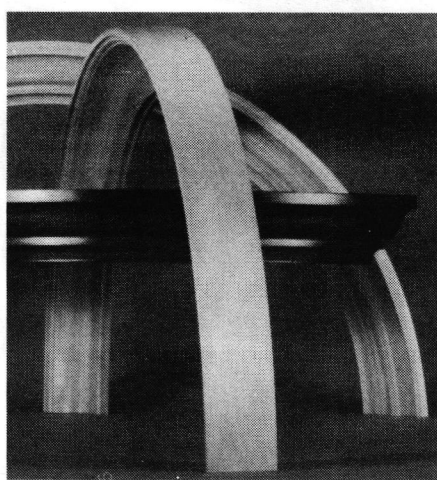

These three circular moldings are a sampling of HENDRICKS WOODWORKING's custom millwork capabilities.

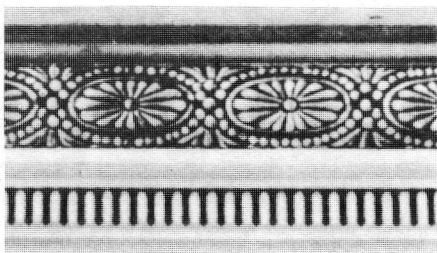

This birch molding (model #6684 that measures 3/4 in. x 3 in.) is part of HOUSE OF MOULDING's large stock of carved and embossed moldings. Write in No. 230

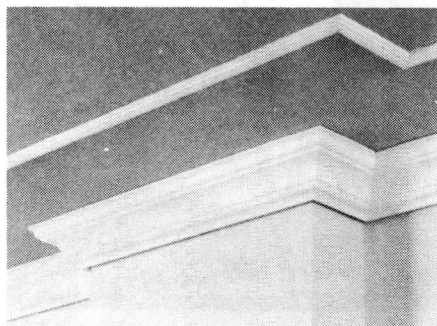

These dense extruded polystyrene (plaster lookalike) moldings are available in over a dozen and a half styles. NMC DECORATION, INC. Write in No. 477

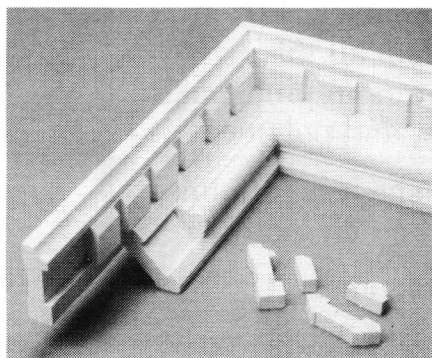

"Selectrim" moldings — domestic and imported hardwoods with wood or plastic inserts — from THE JAMES WOOD COMPANY provide for easy customization because inserts are removable.

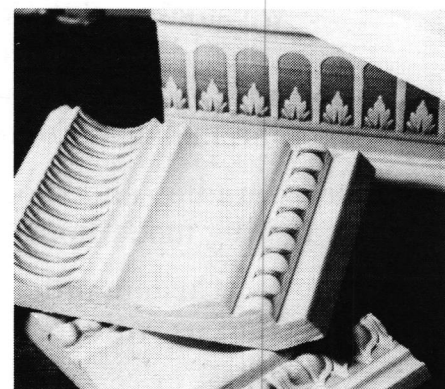

Two examples of WHITE RIVER HARDWOOD's 80 embossed moldings in poplar and red oak. Write in No. 232

2 STYLES: WOOD SUSPENDED CEILING SYSTEMS

ORIGINAL CEILING SYSTEM

- Oak, cherry, poplar
- Rails machined for precise fit
- Fits 2x2 ft. and 2x4 ft. panels
- Un-, pre-, and custom finished
- Adaptable as wainscoating

"SNAP-ON" CEILING SYSTEM

- Fits onto existing metal grid system
- Turns metal grid into distinctive design feature
- Fits 2x2 ft. and 2x4 ft. panels

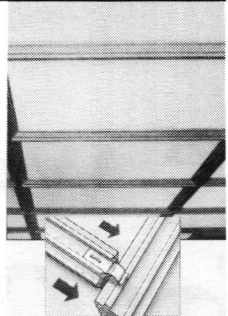

Original Ceiling System

ASK ABOUT OUR:

- English Country Lace • Spindle Rail • Specialty Wood Switchplates
- Furniture Components • Custom Mill Work

PRIME WOOD PRODUCTS, INC.
4430 136th Avenue • Holland, MI 49424
PHONE (616) 399-4700 • FAX (616) 399-8714

WRITE IN NO. 494

CUSTOM MOULDINGS AND ARCHITECTURAL MILLWORK



Phone: (401) 885-5172
Fax: (401) 885-7775

Can match wood sample or drawing using latest computer-controlled equipment

Premium-grade quality manufacturing standards
On time delivery

63 Cedar Avenue, Dept. TB
East Greenwich, RI 02818

WRITE IN NO. 495

When only the best will do

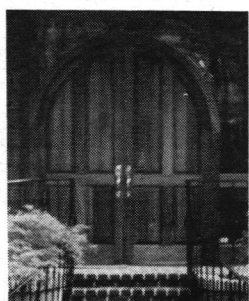

Vermont Custom Doors & More, Inc.
Rd #1 Box 1780 • Fairfield, Vt. 05455 • 802-524-9682

WRITE IN NO. 458



- ARCH/PICTURE FRAME MOLDINGS
- MANTELS • ARCHES • ROSETTES
- KEYSTONES, PLINTHS
- BLUE PRINT TAKE OFFS
- CUSTOM TEMPLATES

987-3404
1-800-536-3404
215-C Naples Dr., Millersville, MD 21108

WRITE IN NO. 880

Traditional Garden Furnishings

Traditional wood-work to enhance the features of your garden. Treillage, pergolas, fences, etc. designed, built and installed by European craftsmen.

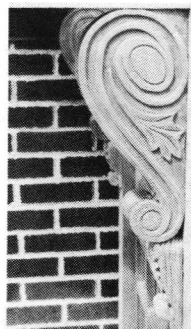

DESIGNCRAFT, INC.
318 North Payne St.
Alexandria, VA 22314
Phone & Fax:
703-549-1272

WRITE IN NO. 755



Don't Replace, Restore...

Weathered windowsills, rusty gutters, rotten fascia boards, worn-out flashings, crumbling chimneys, cracked foundations, leaky basements, weathered siding, popping nail heads, cracking stucco, crumbly copings, splitting concrete, brittle shingles, leaking roofs, rotten decking, worn-out doors, weathered porches, posts and pillars...



with
TUFF-KOTE and TUFFGLASS FABRIC



Tuff-kote's unique waterproof patching system has a patented formula that gives it outstanding strength, adhesion and flexibility. Won't shrink or crack. Permanently seals & weatherproofs all exterior surfaces. Preserve AND protect your next restoration job with Tuff-kote!

Wherever fine paint is sold... or call 1-800-827-2056 for product & ordering information

TUFF-KOTE CO., INC.

- Don't forget Crack-kote Permanent crack repair for all interior surfaces

Quality Home Repair Products for Over 40 Years

WRITE IN NO. 101

Mouldings

- **Huge Catalog** of proprietary mouldings.
- **Mouldings** for residential and commercial use.
- **Historical Mouldings** or duplication of existing.
- **Prefinishing** and sanding of mouldings.
- **Curved** and elastomer mouldings.
- **Carvings**, castings and turnings.
- **Columns** all classical orders.
- **Newels**, balusters, handrails and volutes.
- **Inventory** of our most popular profiles.
- **Design** services to the trade.
- **Architectural** millwork.
- **Samples** available.
- **Exotic** species.
- **Call 1.800.669.9871** for free catalog.

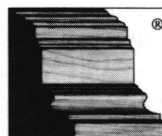

A & B Wood Design Associates, Incorporated
16 Old Mill Rd. P.O. Box 1199 Georgetown, Ct. 06829
Tel. (203)544.9871 Fax. (203)544.1088

WRITE IN NO. 222

The Answers To Your Toughest Restoration And Repair Problems...

WOOD RESTORATION

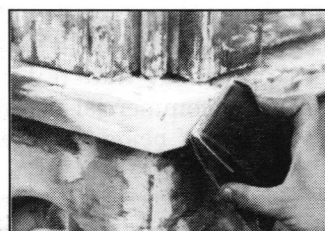

LiquidWood and **WoodEpoxy** give new life to severely rotted windowsills, sash, frames, shutters, columns, antiques, decorative wood elements. The Abatron system is especially valuable when original wood must be saved for historic reasons. **LiquidWood** consolidant reinforces and waterproofs by hardening after penetrating. **WoodEpoxy** structural adhesive putty fills, repairs, and replaces missing wood. It can be sanded, milled, stained, etc., like wood.

ABOCRETE patching and resurfacing cement/grout welds permanently to concrete, metal and wood. Structurally and chemically superior to concrete. Patches and resurfaces floors, driveways, work areas, structures, columns, decks, pitted and spalled surfaces for industrial, marine, institutional and residential uses.

CONCRETE RESTORATION

ABOCRETE patching and resurfacing cement/grout welds permanently to concrete, metal and wood. Structurally and chemically superior to concrete. Patches and resurfaces floors, driveways, work areas, structures, columns, decks, pitted and spalled surfaces for industrial, marine, institutional and residential uses.

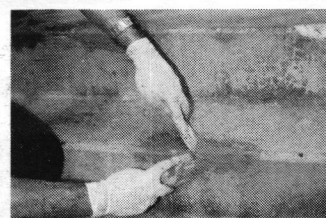

CRACK-INJECTION

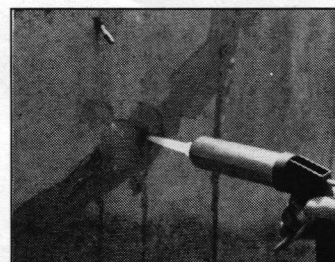

ABOJET structural crack-injection resins are proven to restore structural integrity to cracked load-bearing elements, such as foundations, abutments, swimming pools, concrete pipes, columns, and sculptures. **ABOJET** resin is injected into the crack, filling and welding it. **ABOJET** makes a permanent bond that is stronger

than concrete. **ABOJET** welds concrete masonry, marble, stone, wood, ceramics, metals, stucco, and gypsum.

- *For additional information on these cost-effective restoration materials, contact:*



ABATRON, INC.

33 Center Drive, Dept. TB, Gilberts, IL 60136
Phone: (800) 445-1754 or (708) 426-2200
FAX: (708) 426-5966

WRITE IN NO. 130

Exploring the world of Columns & Capitals

The growing interest in traditional architecture has created a parallel demand for classical columns, which you can now obtain in wood, stone, cast stone, metal, plaster/gypsum — and a range of composites.

BY CLEM LABINE

In his article on moldings (see page 4), Donald Rattner makes a key point about the differences between a cylinder and the classical column. Much of 20th-century "modern" architecture uses a plain cylindrical post where previous generations of architects would have used an architectural column.

As Rattner points out, the cylinder and the classical column express two dramatically different sensibilities. The cylinder is a mathematically pure form — easily produced by machine — and is an ideal expression of the mechanical aesthetic that has dominated much of this century. The classical column, on the other hand, is a modeled form, with a well-defined top and bottom. It is designed not only to perform the

task of supporting loads, but also to visually express *the idea* of supporting a load. The swelling of the column toward the bottom and the use of a base that is heftier than the capital are devices that express an object reacting to gravity and imposed loads. Just as trees evolved in nature with a gradation from bottom to top in response to gravity, the classical designer imparts to the column a distinct top and bottom, creating an element that mediates between the natural world and the abstract world of geometry.

In a previous issue (May/June 1992, p. 14), we looked at the fine points that determine a true classical column. For this discussion, it's sufficient to point out that not all columns on the commercial market can pass the test of being "architec-

Instant Access to Product Literature for Columns & Capitals

If your office qualified to receive the 1993 TRADITIONAL BUILDING CATALOG, you'll find prefiled product literature there for the following suppliers of Columns & Capitals in all materials:

- Architectural Fiberglass Corp. • Chadsworth • Classic Garden Ornaments • Crowning Touch • Cumberland Woodcraft • Driwood Mouldings • Edon Corp. • Enkeboll Designs • Hartmann-Sanders • Historical Arts & Casting • MFG — Molded Fiber Glass • Mohamed Wood Turning Co. • PlastrGlas • Schwerd Manufacturing • Techcrete Architectural Precast • Turncraft

turally correct" in the classical sense. On some jobs, it may be quite sufficient to have a column that merely "looks right." On other projects, it may be essential to ensure that the columns are produced with all the authentic classical refinements.

To assemble the supplier *Source-*

List on the following pages, the editors sent a questionnaire to 208 companies in our database that are known to manufacture or supply columns. From the responses, we selected that 44 companies that appear to hold the greatest interest for our professional audience. ♦



HARTMANN
SANDERS CO

Our Commitment To Architecture.

The importance given to columns in art and architecture through the centuries places a great responsibility on those producing columns today. Such a long and valued tradition demands the utmost care and respect in modern hands.

Our columns and capitals have always met design standards according to the Orders of Architecture. And, for more than ninety years Hartmann-Sanders has been manufacturing the finest authentic Architectural Columns available. In fact, we're so certain of the outstanding quality and durability of our Architectural Columns crafted of Clear All Heart Redwood that we back this product with an unprecedented ten-year warranty against decay and joint separation.

Call us today - or write for information about additions to our expanding product line of other wood and non-wood components and to learn more about the advantages of specifying Hartmann-Sanders.

An Old Company With New Ideas

HARTMANN-SANDERS COMPANY
4340 Bankers Circle • Atlanta, Georgia 30360
(404) 449-1561 • (800) 241-4303

WRITE IN NO. 912

FORTON MG Casting System

*Glass-Fiber Reinforced Gypsum System
For Architectural Elements*

Forton MG

- Interior / Exterior material • Simple to use
- Non-toxic • Wide range of finishes
- Rapid mold cycling • Lightweight

GFRC

- Forton polymer additive for GFRC
- Cem-Fil A-R fiber for GFRC



Distributed by

BALL CONSULTING, LTD.
338 Fourteenth Street
Suite 201
Ambridge, PA 15003
(412) 266-1502
FAX (412) 266-1504

The Leader In Architectural Casting Technology

WRITE IN NO. 726

CHADSWORTH COLUMNS™

The Column Source™

INTRODUCES FIBERGLASS COLUMNS

Load bearing • Impervious to insects • Fire & impact resistant • Ready to prime & paint • Will not rot

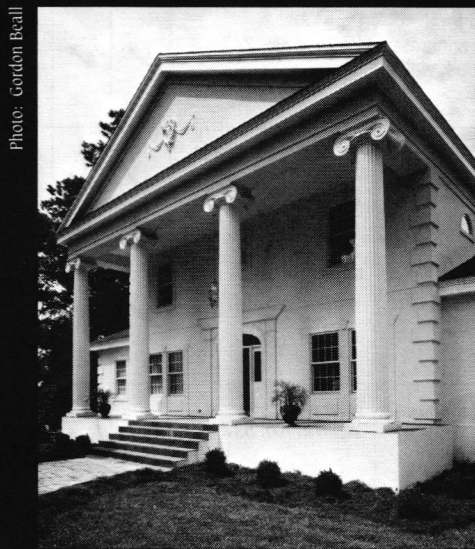

Photo: Gordon Beall

Florence, South Carolina
Columns - 22" x 18" Greek Erechtheum, Fluted



Photo: Jody Hedrick

Alexandria, Virginia
Columns - 12" x 10" Architectural Stock



Photo: Cindy Mahan

Hume, Virginia
Columns - 18" x 13" Roman Doric 12" x 9" Roman Ionic
30" x 24" Roman Corinthian, Fluted

Chadsworth offers a complete selection of architectural columns. Sizes – Diameters 4" to 36", Heights 18" to 40'. By combining our quality products, personalized service and job-site delivery, we are your one-stop column source.

Materials

- Wood
- Fiberglass
- E.P.S.
- Stone
- Marble
- Polyester

Column Styles

- Authentic Replication
- Architectural Classic
- Architectural Stock
- Contemporary
- Art Deco
- Arlington

Capitals

- Decorative Composition*
- Temple of Winds
 - Greek Erechtheum
 - Greek Erechtheum w/ Neck
 - Roman Ionic
 - Scamozzi
 - Renaissance Doric
 - Roman Corinthian
 - Modern Composite

Wood Grain

- Romanesque
- Gothic
- Gothic Renaissance
- Venetian Renaissance
- Italian Composite
- Modern French Ionic w/ Neck
- Italian Renaissance w/ Festoons
- Italian Renaissance w/ Drops

Chadsworth Columns • P.O. Box 53268 • Dept. 21 • Atlanta, GA 30355 • 404/876-5410 Fax 404/876-4492
Atlanta Showroom - 1355 Peachtree Street • Catalog \$3.00 • Catalog Requests 1-800/394-5177

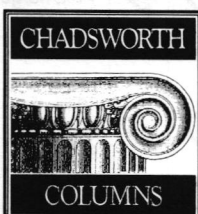

PO. Box 53268
Atlanta, Georgia 30355
(404) 876-5410

Please rush me your free fiberglass column brochure.
Type or print

Name/Title _____

Company _____

Address _____

City/State _____ Zip _____

Phone _____ FAX _____

- Builder Architect Designer Remodeler Developer Real Estate
 Other _____

Mail coupon to: Chadsworth Columns • Catalog Request Center • P.O. Box 11050 •
Goldsboro, NC 27532 • Or call 1-800-394-5177

WRITE IN NO. 18 FOR WOOD COLUMNS & 158 FOR FIBERGLASS

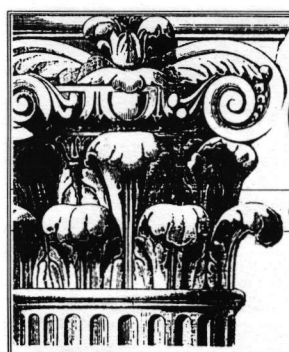

TRADITIONAL BUILDING's COLUMNS & CAPITALS SourceList

CSI# 06400

COMPILED BY CLEM LABINE

COMPANY	SPECIALTY	Literature	Columns	Capitals	Max. Size	Materials	Solid	Stavework, Hollow	Installation Services	% Custom
A & B Wood Design, Inc. P.O. Box 1199, Dept. TB Georgetown, CT 06829 (203) 544-9871	Custom millwork shop, with its own line of copyrighted molding designs, supplies wood columns as part of complete millwork packages.	Free Write in No. 222	✓	✓		Wood as specified	✓	✓	✓	95%
A&M Victorian Decoration, Inc. 2411 Chico Ave., Dept. TB South El Monte, CA 91733 (818) 575-0693	Manufactures a wide range of architectural elements in either gypsum or precast concrete: Columns, molding, mantels, balustrades, wall caps, quoins, fountains, gazebos, etc.	Free Write in No. 747	✓	✓	As specified	Lightweight precast concrete gypsum		✓	✓	40%
Archicast 2527 Broad St., Dept. TB Memphis, TN 38112 (901) 323-8717	Repair and sculpting of old and new capitals, bases, and other elements. Moldmaking and casting specialists. Can cast columns, capitals, and bases from molds in stock.	Prompt response to inquiries Write in No. 14	✓	✓	As specified	Cast stone, precast concrete, reinforced plaster, resins specified	✓	✓		70%
Architectural Facades Unlimited 440 W. Julian St., Suite 240 San Jose, CA 95110 (408) 298-2758	Designs and manufactures cast GFRC columns, balustrades, custom mantels, balusters, gazebos, moldings, finials, etc.	Free Write in No. 147	✓	✓	As specified	GFRC		✓		75%
Architectural Products Mfg. 7470 Greenbush Ave., Dept. TB North Hollywood, CA 91605 (818) 982-2311	Manufacturers of GRG, modified GRG, and GFRC architectural elements, including columns, capitals, mantels, moldings, ceiling panels, etc. Stock and custom columns.	Free Write in No. 897	✓	✓	48 in. dia. 22 ft. high (stock); custom as specified	GRG, Forton MG, cast concrete, GFRC		✓	✓	60%
Art Home Studios 64 Huron St., Dept. TB Brooklyn, NY 11222 (718) 383-0603	Sculptural studio providing design, fabrication, and reproduction of columns and other architectural elements in a wide range of materials.	Free Write in No. 643	✓	✓	As specified	FRP, GFRC, plaster, cast stone, cast marble	✓	✓	✓	100%
Ball Consulting 338 14th Street, Suite 201 Ambridge, PA 15003 (412) 266-1502	Supplies Forton modified-gypsum casting system for creating interior and exterior architectural elements, including columns and capitals. Consulting and technical service.	Free Write in No. 726				Forton MG polymer-modified gypsum				100%
Campbellsville Industries, Inc. Taylor Blvd. P.O. Box 278 Campbellsville, KY 42718 (800) 467-8135	Fabricator of architectural elements, including columns and capitals, in a range of materials, such as aluminum, wood, copper, and rigid urethane.	Free Write in No. 582	✓	✓	30 in. dia. 28 ft. high	Aluminum, wood, plaster, copper		✓	✓	75%
Chadsworth Columns P.O. Box 53268, Dept. TB Atlanta, GA 30355 (404) 876-5410	Major supplier of architecturally correct columns in all of the classical orders. Available in both traditional stavework wood columns and new fiberglass models. Structural and ornamental.	Free Write in No. 158 for fiberglass columns; No. 18 for wood columns	✓	✓	36 in. dia. 40 ft. high	Wood, fiberglass		✓		50%
Classic Architectural Specialties 3223 Canton St., Dept. TB Dallas, TX 75226 (800) 662-1221	Offers complete selection of ornamental trim and architectural details, including classical and novelty columns. Victorian millwork, moldings, entry systems, cupolas, ceiling panels.	Free Write in No. 904	✓	✓	36 in. dia. 36 ft. high	Wood, plaster, formed aluminum, modified gypsum, composites	✓	✓		50%
Classic Garden Ornaments, Ltd. 814 Ridge Terr., Dept. TB Evanston, IL 60201 (800) 852-2299	Supplies columns, pilasters, capitals, bollards, balls, bases, and finials in limestone and cast stone.	Free Write in No. 333	✓	✓	24 in. dia. 12 ft. high	Cast stone, limestone	✓	✓		50%
Classical Woodworks, Inc. 20 Mill St., Dept. TB Healdsburg, CA 95448 (707) 433-0180	Specializes in stairs, custom stair parts, columns, mantels, Victorian millwork and trim, moldings.	Free	✓	✓	30 in. dia. 30 ft. high	Wood, GFRC		✓		10%
Colonial Castings, Inc. 15301 N.W. 34th Ave., Dept. TB Miami, FL 33054 (305) 688-8901	Extensive range of load-bearing aluminum columns.	Free	✓	✓	8 in. dia.	Aluminum		✓		5%
Crowning Touch, Inc. 8902 Roschill Rd., Dept. TB Lenexa, KS 66215 (913) 888-2929	Complete line of pilasters and columns with bases and capitals: Plain, fluted, and square. Also ceiling medallions, crown moldings, panel moldings, etc.	Free	✓	✓	12 in. dia. 14 ft. high	Plaster, composite, rigid polyurethane		✓		5%
Cumberland Woodcraft Co. P.O. Drawer 609, Dept. TB Carlisle, PA 17013 (717) 243-0063	Complete line of solid hardwood carved capitals, carved all 4 sides. Fluted wood and Marbleine columns. Appliques also available.	Free Write in No. 131	✓	✓	12 in. dia. 10 ft. high	Wood, marble composite	✓	✓		25%
J.A. Dawley Fine Woodworking 1938 Chase Rd., Dept. TB Waterloo, NY 13165 (315) 539-2555	Provides true classical columns, up to 14 ft. long and 22 in. dia.; will quote any custom turnings larger. Exact duplications for interior or exterior: Columns, posts, newels, and balusters.	Free Write in No. 420	✓	✓	22 in. dia. 14 ft. (larger on custom basis)	Wood		✓		50%
DEC Associates 1620 S. Sinclair St., Dept. TB Anaheim, CA 92806 (714) 937-0400	Offers line of standard columns, as well as custom manufacturing. Can also supply custom aggregate finishes.	Free Write in No. 992	✓	✓	60 in. dia. height to spec	Fiberglass FRP, FRG		✓		50%
Dixie-Pacific Mfg. Co. 1700 West Grand Ave., Dept. TB Gadsden, AL 35901 (205) 442-4513	Complete line of turned wood architectural products, including custom columns, decorative capitals, spindles, hand rails, and more.	Free	✓	✓	36 in. dia. 24 ft. high	Wood		✓		45%
DMS Studios 5-50 51st Ave., Dept. TB Long Island City, NY 11101 (718) 937-5648	Sculpture studio provides handcarving of classical capitals and other architectural ornament in marble, limestone, or cast bronze.	Free Write in No. 910		✓	As specified	Marble, limestone, bronze	✓			100%
Edon Corporation 1160 Easton Rd., Dept. TB Horsham, PA 19044 (215) 672-8050	Has hundreds of column sizes and shapes available from existing tooling, along with many sizes and shapes of capitals. Custom work also available.	Free Write in No. 189	✓	✓	48 in. dia. 27 ft. high	FRP, FRG		✓		20%

the standard of quality since 1860

SCHWERD'S wood columns

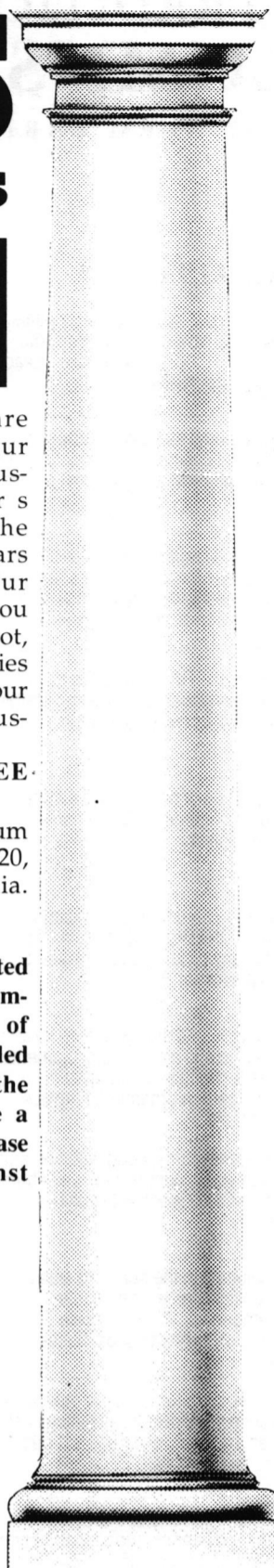
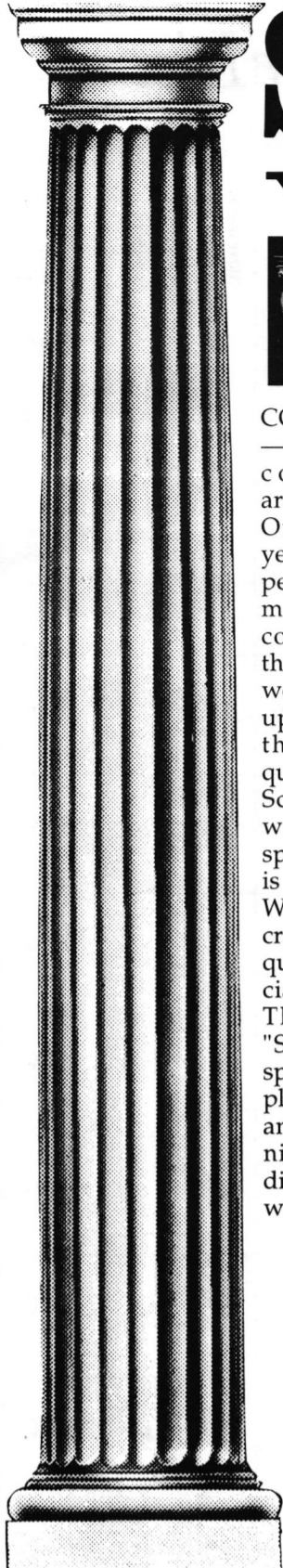

No. 140 Scamozzi

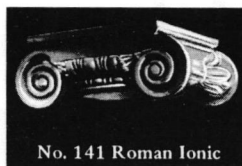

No. 141 Roman Ionic

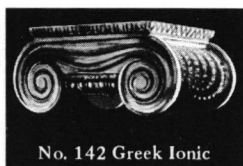

No. 142 Greek Ionic

COLUMNS

Schwerd columns are durable. Our 120+ years of experience in manufacturing wood columns has proven that the durability of a wood column depends upon the strength of the joint and the quality and thickness of the wood. Schwerd column construction was developed to meet each specific requirement. The wood is thoroughly seasoned Northern White Pine. The pride of craftsmanship and skilled techniques acquired by 120 years of specialized experience is applied. The resulting product is a "Schwerd Quality Column" specified by architects with complete confidence. Both standard and detail columns can be furnished from 4 in. to 50 in. in diameter and up to 35 ft. in length with matching pilasters.



No. 150 Roman Corinthian

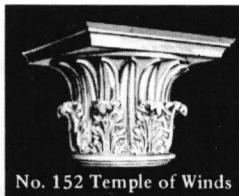

No. 152 Temple of Winds



No. 144 Modern Ionic

If you are one of our old customers during the many years since our beginning in 1860, you know our product; if not, send us your inquiries and orders and join our list of satisfied customers.

SEND FOR OUR FREE CATALOG

Schwerd's complete aluminum bases for 8, 10, 12, 14, 16, 18, 20, 22, 24, 26, 28, and 30 in. dia. columns.

Schwerd's - Aluminum ventilated plinth and aluminum turned member base are manufactured of thick metal and are recommended for all exterior columns in the above diameters to provide a maintenance free, seamless base which is guaranteed against deterioration for a lifetime.



A. F. SCHWERD MANUFACTURING COMPANY
 telephone: 412-766-6322
 3215 McClure Avenue Pittsburgh, Pa. 15212

WRITE IN NO. 161

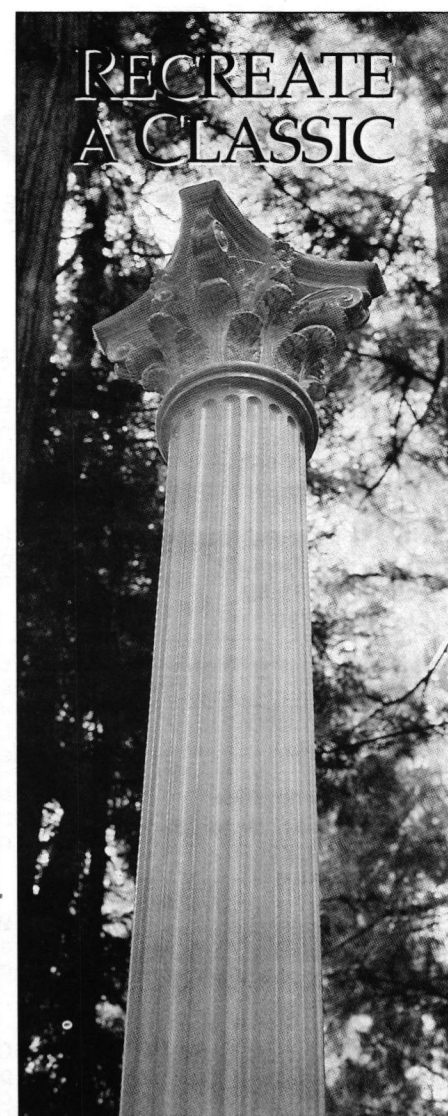

RECREATE A CLASSIC

Capture the elegance of yesterday with columns crafted to today's highest standards in materials and workmanship. Turncraft Architectural Columns feature dimensions and heights in keeping with Vignola's guidelines for classic Greek and Roman columnar orders and today's building customs. Available in sizes to meet virtually every interior and exterior design application - from 8" to 30" in diameter and 8' to 30' in length. Practical kiln-dried Ponderosa Pine, durable clear heart Redwood or dramatic Oak. Fluted or unfluted. With eye-catching optional ornamental capitals or durable polyurethane cap & base sets. Also in economical Stock/ House Designs. Round & Square. Fluted or unfluted.



A DIVISION OF CASCADE WOOD PRODUCTS, INC.
 1-800-423-3311 Fax 503-826-1393

©1992 Turncraft

WRITE IN NO. 15

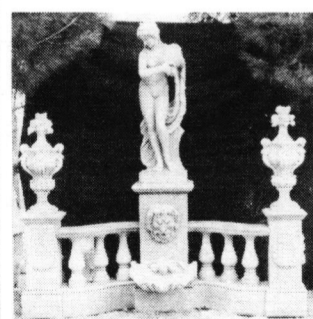

**Exquisitely Detailed
Hand-Carved Vicenza Stone**

Extensive line of statues, mantelpieces, fountains, wells, columns, balustrades, benches, tables, gazebos, busts, urns, lampposts, ornaments, etc., direct from our own ateliers in Italy. We also custom-make pieces of any style or dimension. Send for free brochure or enclose \$10 for full catalog.

Garden Ornaments Stone, U.S., Inc.,
 P.O. Box 1451 · Roswell, GA 30077 · Fax 404/640-7177
 In Italy: Garden Ornaments Stone srl · V.le dell'Industria 67/71
 36100 Vicenza · Fax 011-39-444-961601

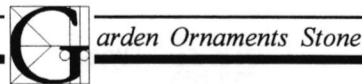

WRITE IN NO. 442

JA DAWLEY
fine woodworking
 Classic Columns • Custom Turnings
 Custom Storm and Screen Doors
 1938 Chase Road, Waterloo, NY 13165
 Phone (315) 539-2555 FAX (315) 539-5047
 Call or write for a free brochure.

WRITE IN NO. 420

**TECHCRETE
ARCHITECTURAL PRECAST**

CUSTOM COLUMNS—
 CAST STONE AND
 PRECAST CONCRETE

CONTRACT DESIGN DEPT.
 AND MOLD SHOP

SIMULATED FLORIDA
 KEYSTONE

TECHCRETE ARCH. PRECAST
 12920 ALEXANDRIA DR.
 OPA LOCKA, FL 33054
 (305) 688-1461
 (305) 688-3107 (FAX)

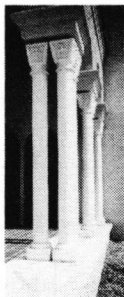

WRITE IN NO. 12

FAGAN DESIGN

A complete line of architectural columns and turnings. Our columns can be based on your designs — or the traditional orders of architecture.

Large or small, our columns and turnings surpass the toughest architectural standards, and we use only the finest materials and advanced methods of construction.

Further, we offer:

- ◆ Moldings ◆ Curved crowns
- ◆ Porch Posts ◆ Capitals
- ◆ Carvings ◆ Fluting & spiral rope twists
- ◆ Other large turnings
 (Diameters to 12 ft.; Lengths to 36 ft.)

Fagan Design & Fabrication
 44 Railroad Ave., Dept. TB, West Haven, CT 06516
 Phone: (203) 937-1874 Fax: (203) 937-7321

WRITE IN NO. 821

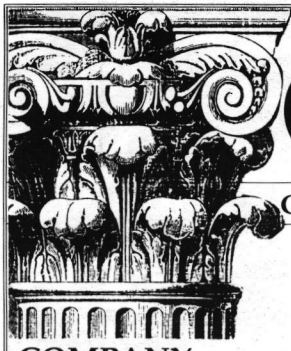

TRADITIONAL BUILDING's COLUMNS & CAPITALS SourceList

CSI# 06400

COMPILED BY CLEM LABINE

COMPANY	SPECIALTY	Literature	Columns	Capitals	Max. Size	Materials	Solid	Stave-work, Hollow	Installation Services	% Custom
Fagan Design & Fabrication 44 Railroad Ave., Dept. TB West Haven, CT 06516 (203) 937-1874	Hand-turned custom columns, capitals, cylinders, rope twists, and spirals, etc. Large turnings produced in any species. Exact duplications for restoration.	Free <i>Write in No. 821</i>	✓	✓	48 in. dia. 26 ft. high	Wood, cast stone, metal, precast concrete, FRP, cast & fabricated metal	✓	✓		100%
Felber Ornamental Plastering P.O.Box 509, Dept. TB Ardmore, PA 19003 (215) 642-4710	Sculpture studio has a wide range of molds to produce cast columns and capitals in a wide range of materials. Custom casting available.	Free <i>Write in No. 289</i>	✓	✓	24 in. dia. 20 ft. high	Plaster, FRG, modified gypsum	✓	✓		100%
Fiberglass Masters Technologies, Inc. 1609-P Harmer St., Dept. TB Levittown, PA 19057 (215) 943-4567	Columns and capitals in FRP or GFRC in any size or style. Custom; structural and non-structural; decorative; textured and stone finishes; any color. Also cornices & railing systems.	Free <i>Write in No. 471</i>	✓	✓	As specified	FRP, GFRC, FRG, modified gypsum		✓		90%
Fibertech Corporation 250 S. Depot St., Dept. TB Pendleton, SC 29670 (803) 646-9990	Manufactures FRP columns up to 3/16-in. thick. Also supplies load-bearing Marbleine columns in diameters up to 12 in.	Free	✓	✓	As specified	FRP, marble composite	✓	✓		2%
Fischer & Jirouch Co. 4821 Superior Ave., Dept. TB Cleveland, OH 44103 (216) 361-3840	Wide selection of handcrafted architectural ornament for interior and exterior — including classical capitals.	Free <i>Write in No. 196</i>	✓	✓		P.C. plaster with hemp		✓		20%
Garden Ornaments Stone, Inc. P.O. Box 1451, Dept. TB Roswell, GA 30075 (404) 640-6705	Offers hand-carved Italian sandstone columns, pedestals, obelisks, and capitals. Can be crafted in any style, shape, or size. Special finishes available.	Free <i>Write in No. 442</i>	✓	✓	As specified	Vicenza stone	✓			70%
C.G. Girolami P.O. Box 706, Dept. TB Clifton, IL 60927 (815) 694-3700	Manufactures and stocks a large inventory of authentic historic architectural elements: Columns & capitals, ornamental moldings, fountains, garden ornament, fireplace surrounds, etc.	Free <i>Write in No. 753</i>	✓	✓	As specified	Plaster, FRG, cast stone, GFRC				75%
Hartmann-Sanders Company 4340 Bankers Cir., Dept. TB Atlanta, GA 30360 (404) 449-1561	Custom architectural wood columns and capitals in wood, composites, and fiberglass. Stock turnings in wood with polyurethane caps and bases.	Free <i>Write in No. 912</i>	✓	✓	44 in. dia. 40 ft. high	Wood, plaster, composites		✓		90%
Henderson, Black & Green P.O. Box 589, Dept. TB Troy, AL 36081 (205) 566-5000	Wood columns in the standard classic orders. Also supplies pilasters and square columns, and components. Also complete column systems, polyurethane caps, bases, and capitals.	Free <i>Write in No. 38</i>	✓	✓	30 in. dia. 30 ft. high	Wood		✓		10%
Historical Arts & Casting, Inc. 5580 West Bagley Park Road West Jordan, UT 84088 (801) 569-2400	Specializes in restoration and replication of cast architectural details, including custom-designed and manufactured load-bearing columns and capitals.	Free <i>Write in No. 121</i>	✓	✓	18 in. dia. 25 ft. high	Cast iron, cast aluminum		✓	✓	90%
Josefs Art Woodturning & Son, Inc. 71 Sewell St., Dept. TB Hempstead, NY 11550 (516) 489-3080	Wood columns in any species; interior or exterior; load-bearing or non-load bearing; fluted, reeded, roped styles. Also posts and other turnings, custom or production.	Free <i>Write in No. 31</i>	✓	✓	30 in. dia. 40 ft. high	Wood		✓		95%
David Kucera, Inc. 85 Wythe Ave., Dept. TB Brooklyn, NY 11211 (718) 387-6206	Custom manufacturing of columns & capitals; specialists in architectural details and replication in Glass Fiber Reinforced Concrete.	Free <i>Write in No. 459</i>	✓	✓	As specified	FRP, GFRC, plaster, cast stone	✓	✓		100%
Mohamad Wood Turning Co. 28 Meadow St., Dept. TB Brooklyn, NY 11206 (718) 417-0025	Custom wood columns in all classical styles; load-bearing for interior or exterior use. Can furnish fluting, reeding, rope twists, and custom carving. Fractional columns.	Free <i>Write in No. 5</i>	✓	✓	32 in. dia. 30 ft. high	Wood		✓		90%
Moonlight Molds, Inc. 1632 W. 139th St., Dept. TB Gardena, CA 90249 (310) 538-9142	Architectural cast products, including columns, cornices, domes, coves, etc., in a wide range of materials.	Free	✓	✓	72 in. dia. 20 ft. high	Cast stone, plaster, modified gypsum, precast concrete, FRP, FRG, GFRC	✓	✓		50%
Outwater Plastics, Inc. 4 Passaic St., Dept. TB Wood-Ridge, NJ 07075 (800) 631-8375	Columns: plain or fluted, square or round, tapered or non-tapered, with Greek, Roman, Colonial or other classical capitals. Extensive line of other molded ornament.	Free <i>Write in No. 493</i>	✓	✓	24 in. dia. 24 ft. high	Wood, plaster, styrene, composites, aluminum		✓		20%
Pagliacco Turning & Millwork P.O. Box 225, Dept. TB Woodacre, CA 94973 (415) 488-4333	Standard and custom wood columns in all the classical styles. Columns are load-bearing, and can be supplied in full, 3/4, 2/3, or 1/2 cross sections.	Free <i>Write in No. 707</i>	✓	✓	24 in. dia. 20 ft. high	Wood		✓		80%
A. F. Schwerd Mfg. Co. 3215 McClure Ave., Dept. TB Pittsburgh, PA 15212 (412) 766-6322	Both standard and custom columns can be furnished with matching pilasters. Complete aluminum bases available for even-diameter exterior columns. 10 styles of capitals.	Free <i>Write in No. 161</i>	✓	✓	50 in. dia. 35 ft. high	Wood columns with wood or aluminum bases.		✓		95%
Seal Reinforced Fiberglass 23 Bethpage Rd., Dept. TB Copiague, NY 11726 (516) 842-2330	Columns, capitals, bases, column covers, cornices, balustrade systems, domes, decorative moldings, pools, rock fountains, custom shapes.	Free <i>Write in No. 462</i>	✓	✓	24 in. dia. 18 ft. high	FRP		✓	✓	50%
Somerset Door & Column Co. Box 328, S. Edgewood Avenue Somerset, PA 15501 (814) 445-9608	Classical columns in standard designs — or can custom-build columns to specification. Can prepare detailed working drawings for client approval.	Free <i>Write in No. 66</i>	✓	✓	40 in. dia. 40 ft. high	Wood, FRP		✓		50%+
Superior Aluminum Products, Inc. 105 Francis St., Dept. TB Russia, OH 45363 (513) 526-4065	Aluminum columns, load-bearing and fluted, in both round and square designs. Colors available. Cast caps and bases in standard and ornamental styles: Doric, Corinthian, and Scamozzi.	Free <i>Write in No. 70</i>	✓	✓	30 in. dia. 40 ft. high	Aluminum		✓		15%

MEET THE INCREDIBLE NEW COLUMN ONLY HB&G COULD HAVE CREATED!



INTRODUCING PERMACAST™ COLUMNS

- Lifetime warranty
- Maintenance-free
- Weatherproof
- Insect-proof
- Easy to install
- Loadbearing
- Architecturally correct
- Authentically detailed

▶ Call toll-free 1-800-264-4HBG



**THE COLUMN
CONNECTION**

Join **The Column Connection**, HB&G's free nationwide support system for building professionals. Call toll-free **1-800-264-4HBG** for details, catalogs and information about important new HB&G building products.

Columns/Turned Posts/Polywood Moldings and Entrance Features/Spindles/Newels/Rails/Sidelights/Door Trim/Mantels/Ironing Board Cabinets



Henderson, Black & Greene, Inc.

P.O. Box 589, Troy, AL 36081 • (205) 566-5000 • FAX (205) 566-4629

COPYRIGHT 1993, HB&G, INC.

**ADDING CURB APPEAL
BY THE TRUCKLOAD!**

WRITE IN NO. 38

Old World Elegance... New World Charm

Sculpted Ornamental Plaster and Composition Architectural Elements For Commercial or Residential Projects.

Over 90 years of finely detailed craftsmanship reproduced in a wide range of materials, elements-unique in their detail and intricate patterns. Our architectural elements create a style and quality that's unmatched. Yet we are competitively priced.

We specialize in custom applications for hotels, restaurants, casinos, restoration projects and luxury homes. We invite your inquiry, for more information call:

C.G. Girolami

(815-694-3700) Fax 815-694-3770
Clifton, Illinois 60927

WRITE IN NO. 753

Josef's Art Woodturning & Son Inc. Manufacturers of Custom Woodturnings

- STAIR BALUSTERS & POSTS
- COLUMNS & ORNAMENTAL CAPITALS
- CORNER BLOCKS
- WOOD BALLS
- DISPLAY TABLE LEGS
- ROPE/TWISTING/REEDING
- RING MOLDINGS
- STOCK RAILS & FITTINGS

10,000 sq.ft. Production Facility
Over Ten Years
Serving The Trade

Phone or Fax for a Brochure

(516) 489-3080

Fax **(516) 489-3148**

71 Sewell Street, Hempstead, New York 11550



WRITE IN NO. 31

EDON fiberglass COLUMNS CAPITALS CORNICES



HISTORICAL
ARCHITECTURAL
ORNAMENTATION
CONTEMPORARY

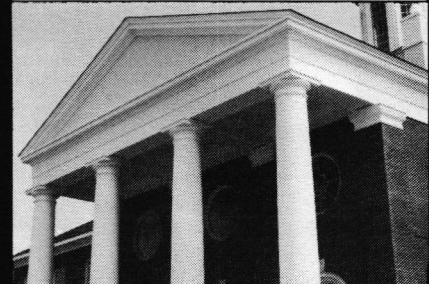

COLUMNS ■ PEDIMENTS

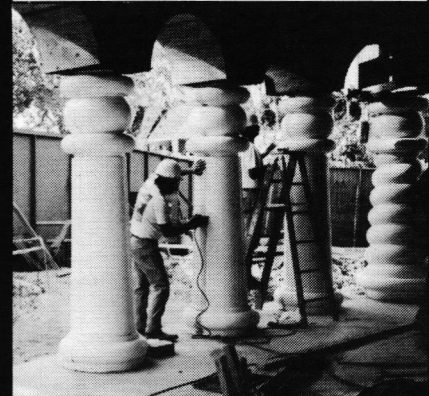

SPECIALTY COLUMNS



COLUMNS ■ MOLDINGS

EDON FIBERGLASS

800-523-2539
FAX-215-672-9014
1160 EASTON RD.
HORSHAM, PA 19044
215-672-8050

WRITE IN NO. 189



TRADITIONAL BUILDING's COLUMNS & CAPITALS SourceList

CSI# 06400

COMPILED BY CLEM LABINE

COMPANY	SPECIALTY	Literature	Columns	Capitals	Max. Size	Materials	Solid	Stavework, Hollow	Installation Services	% Custom
Techcrete Architectural Precast 12920 Alexandria Drive Opa Locka, FL 33054 (305) 688-1461	Custom manufactures cast stone columns primarily in the Doric and Tuscan orders with classical entasis. Also produces a wide range of other cast architectural ornament.	Free <i>Write in No. 12</i>	✓	✓	24 in. dia. 24 ft. high	Cast stone	✓	✓	✓	100%
Treadway Industries, Inc. 111 Weber Avenue, Dept. TB Leesburg, FL 34748 (904) 326-3313	Custom expanded polystyrene used for columns and capitals and other architectural shapes. Classical styles; finishes include hard coats with synthetics.	Free	✓	✓	As specified	Polystyrene		✓		100%
Turncraft P.O. Box 2429, Dept. TB White City, OR 97503 (800) 423-3311	Manufactures wood columns and ornamental capitals both in Architectural Series and stock residential patterns: Pine, poplar, cherry, redwood, and oak.	Free <i>Write in No. 15</i>	✓	✓	30 in. dia. 30 ft. high	Wood		✓		10%
Worthington Group P.O. Box 53101, Dept. TB Atlanta, GA 30355 (800) 872-1608	Supplier of true classical columns in all the basic orders. Also supplies balustrades, moldings, and other architectural elements in a variety of materials.	Free <i>Write in No. 163</i>	✓	✓	30 in. dia. 30 ft. high	Wood, FRG, GFRC, GFRC		✓		40%

COLUMNS & CAPITALS PORTFOLIO

For more information on these companies, consult the SourceList on pages 32-36.

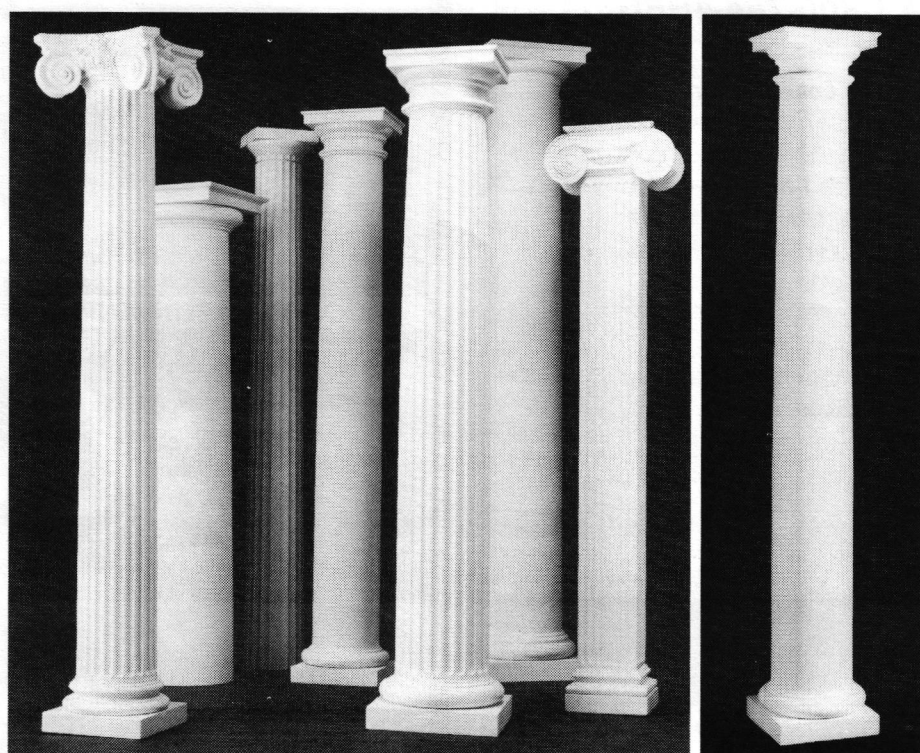

CHADSWORTH now supplies fiberglass columns (right) as well as architecturally correct wood columns (left). Write in No. 158 for fiberglass columns; No. 18 for wood columns



The Ionic capital and interior moldings in high-density polyurethane are part of the Crowning Touch Collection available from OUTWATER PLASTICS. Write in No. 493

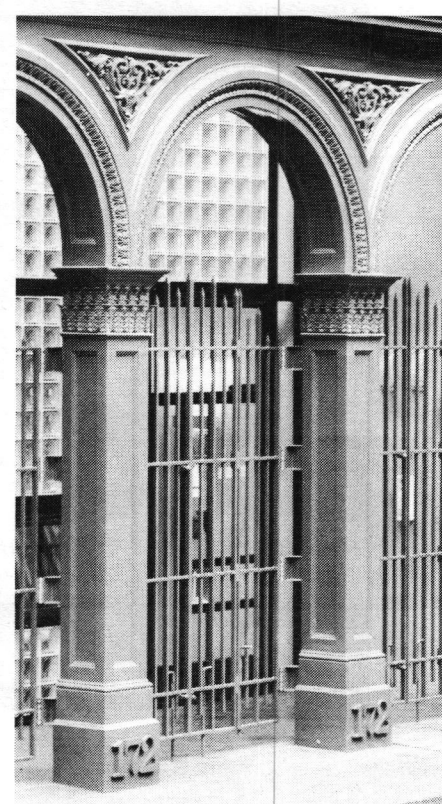

Cast iron columns, capitals, and arches were created for the restoration of a 19th-century cast iron building by HISTORICAL ARTS & CASTING. Write in No. 121

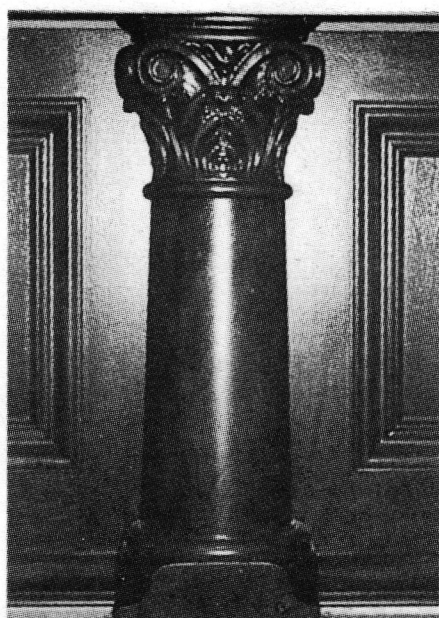

This muscular hardwood column was part of an elaborate bar installation custom-fabricated by CUMBERLAND WOODCRAFT. Write in No. 131

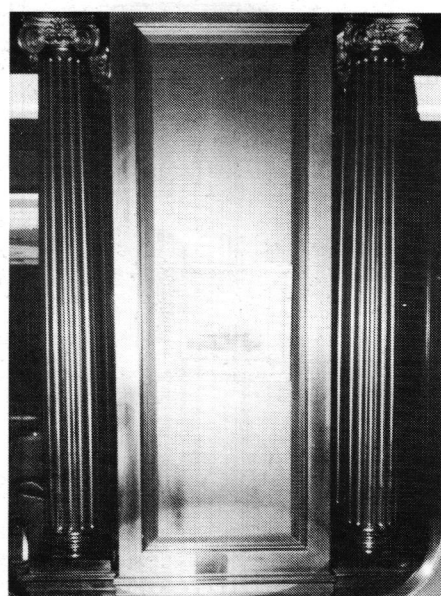

FAGAN DESIGN & FABRICATION fabricated these elegant fluted mahogany Ionic columns for a commercial interior. Write in No. 821

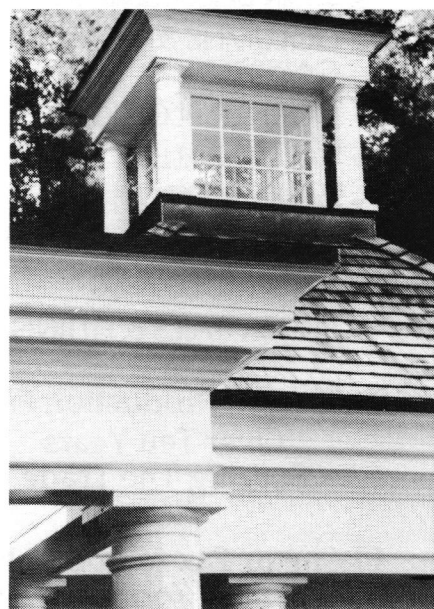

Cupola with Tuscan columns was fashioned in the shops of A&B WOOD DESIGN. Write in No. 222

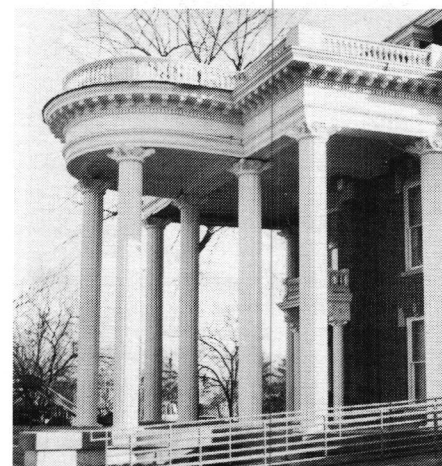

SUPERIOR ALUMINUM PRODUCTS furnished the 20-ft. aluminum columns and capitals for this classical revival portico. Write in No. 70

MOHAMAD WOOD TURNING CORP.

Spirals 18" Dia - 9' Long
Columns 36" Dia - 24' Long
Curved Back Chair Legs

Flutes, Reeds

← Hollow Spirals

Balusters, Posts

Circular Moldings

Twisted Diamond Cuts →

Custom Hand Rails
and Stair

All Types of

Custom Spiral

and Turning.

From 1-1,000 Pieces.

28 Meadow St.
Brooklyn, NY 11206
(718) 417-0025
FAX (718) 417-0021

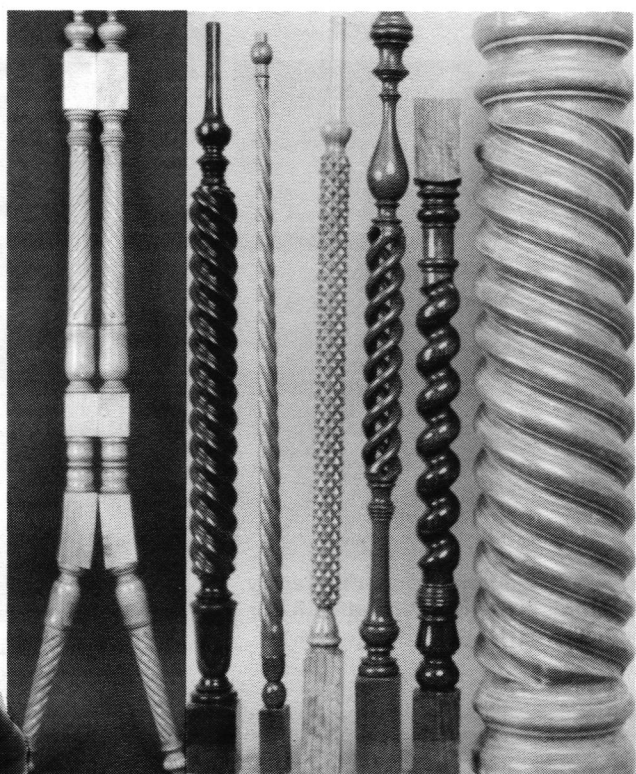

WRITE IN NO. 5

24 Page Catalog

PAGLIACCO

Catalog of Wood
BALUSTERS
NEWEL POSTS
PORCH POSTS
RAILINGS
COLUMNS
CYLINDERS &
CUSTOM TURNING

ARCHITECTURAL MILLWORK 6.9/Pa

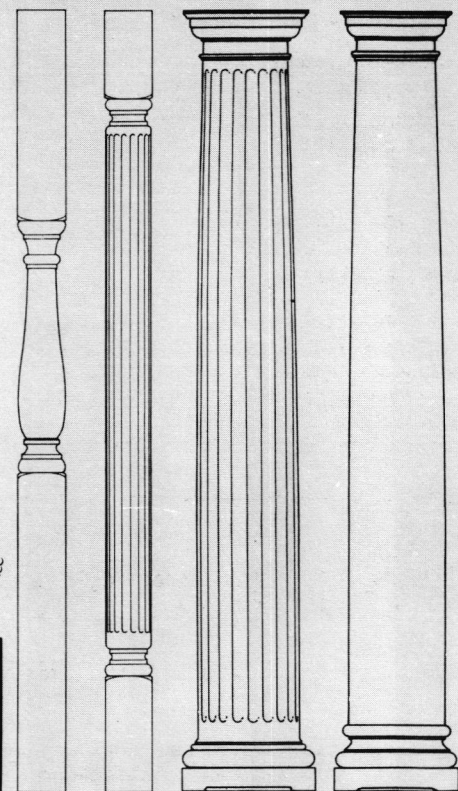
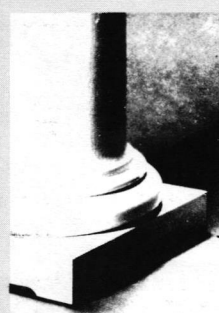
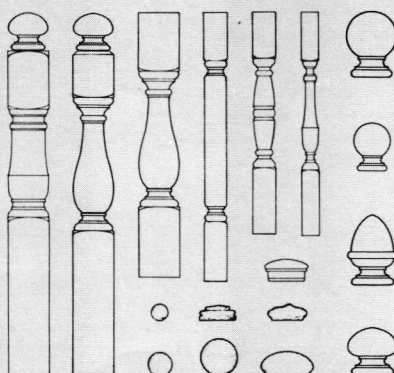

PAG 3

Our catalog shows a complete range of architectural turnings. All products incorporate design authenticity, skilled craftsmanship and quality materials.

VICTORIAN TURNINGS & MILLWORK

Designs are based on manufacturers' catalogs from 1870 to 1920.

CLASSIC COLUMNS

Accurately reflect the Greek & Roman orders with true entasis & details.

CALIFORNIA REDWOOD

All products are available from decay & termite resistant clear-heart Redwood. Interior turnings are available from Oak & Mahogany.



P.O. Box 225TB
Woodacre, CA 94973
Telephone:
(415) 488-4333

For your catalog, send \$6 (no charge to designers, builders & dealers when requested on Company letterhead).

WRITE IN NO. 707

Architectural Precast Products



- Gazebos • Balustrades • Pavers
- Columns Fountains • Wallcaps
- Stair Treads • Quoins
- Fireplace Mantels and Much More...

Custom Specialists Since 1979

A & M VICTORIAN DECORATIONS, INC.

2411 Chico Ave., So. El Monte, CA 91733
(818) 575-0693 • Fax: (818) 575-1781

WRITE IN NO. 747

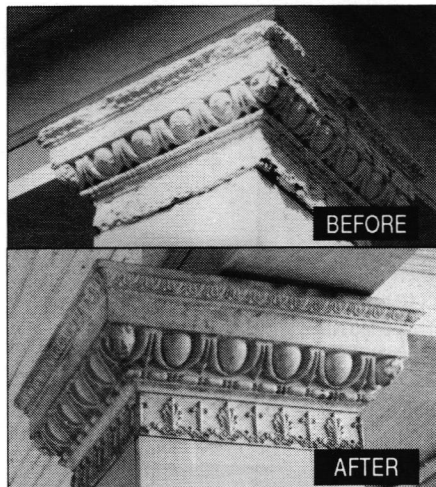

Porch Capitals, Memphis

Capitals Repaired
& Re-created ~
Casting in Plaster
& Concrete

Dan Spector
(901) 323-8717

2527 Broad St., Memphis, TN 38112

ARCHICAST

WRITE IN NO. 14

WORTHINGTON

PREMIER ARCHITECTURAL PRODUCTS

1-800-872-1608



Catalog \$3.00

WORTHINGTON GROUP, LTD.
P.O. Box 53101
Atlanta, GA 30355
404-872-1608

WRITE IN NO. 163

COLUMNS & CAPITALS PORTFOLIO

For more information on these companies, consult the SourceList on pages 32-36.

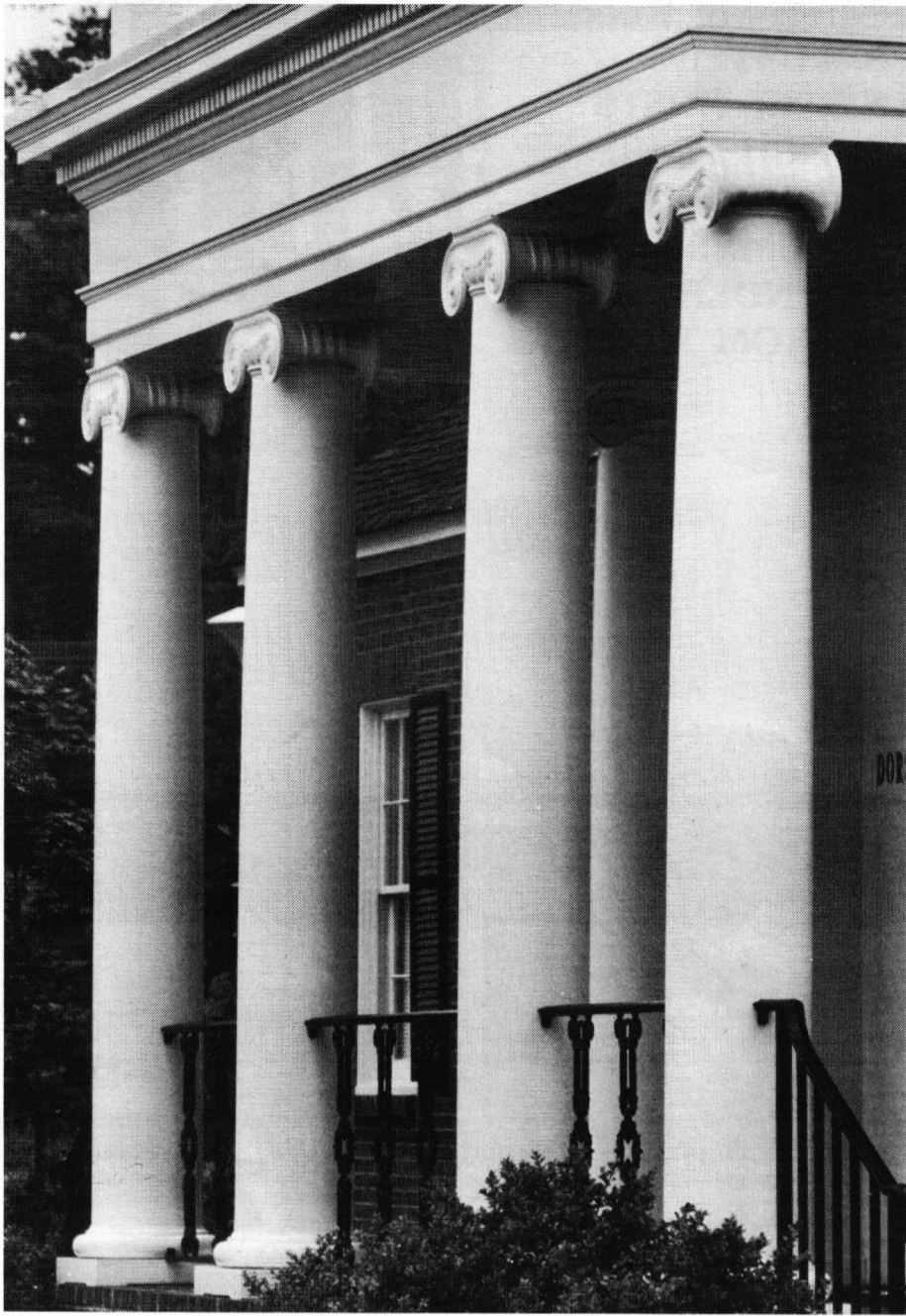

HARTMANN-SANDERS supplied these large Ionic columns for the portico of a neo-classical commercial building. Write in No. 912



Columns for this impressive Doric entry were engineered and fabricated in FRP by EDON CORP. Write in No. 189



Finely detailed moldings for this entry in the Ionic order were sculpted in the studios ARCHICAST. Write in No. 14

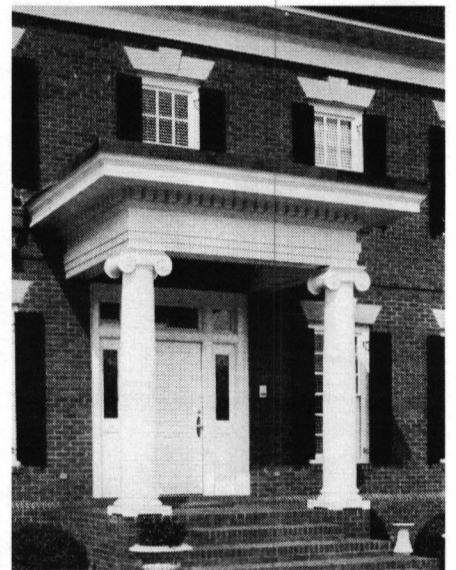

The porch of this Georgian residence was fitted with Ionic columns from HENDERSON, BLACK & GREENE. Write in No. 38

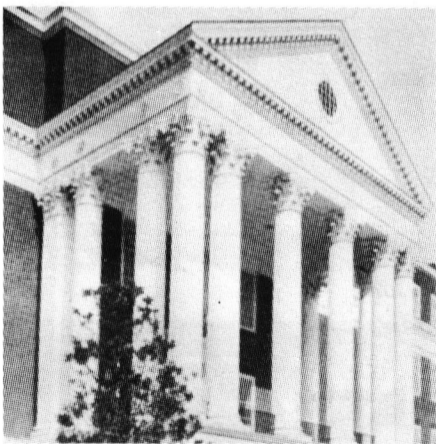

The library at the Univ. of Maryland, College Park, Md., features a massive portico in the Corinthian order supplied by SCHWERD MFG. Write in No. 161



Massive wood columns in the Tuscan order were fabricated for this covered patio by PAGLIACCO TURNING & MILLING. Write in No. 707



Pergola with smooth Tuscan columns was fabricated for this commercial display by J.A. DAWLEY FINE WOODWORKING. Write in No. 420

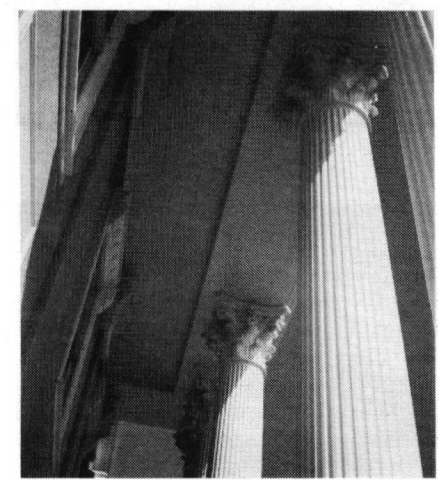

TURNCRAFT supplied the two-story fluted columns with the deeply sculpted Corinthian capitals for this residential porch. Write in No. 15

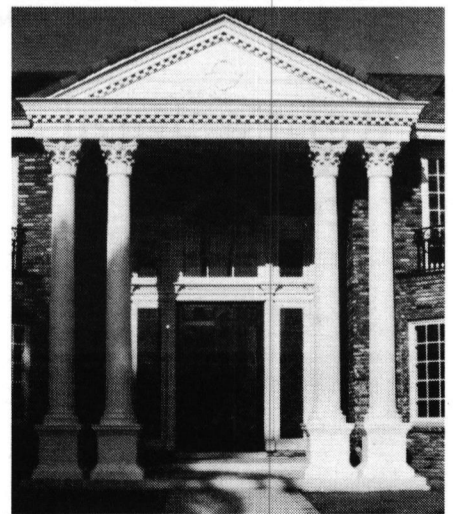

Corinthian columns and capitals were cast in the Forton polymer-modified gypsum system by ARCHITECTURAL PRODUCTS MFG. Write in No. 897

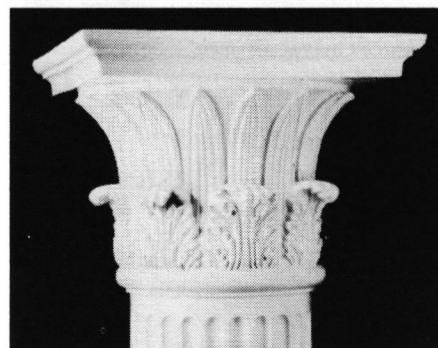

Temple of the Winds capital is one of a series of authentic classical capitals and columns available from WOR-THINGTON GROUP. Write in No. 163

**FIBERGLASS
MASTERS
TECHNOLOGIES**
INC.

Manufacturers of Fiberglass Reinforced Plastics
1609 Harmer Street, Levittown, PA 19057

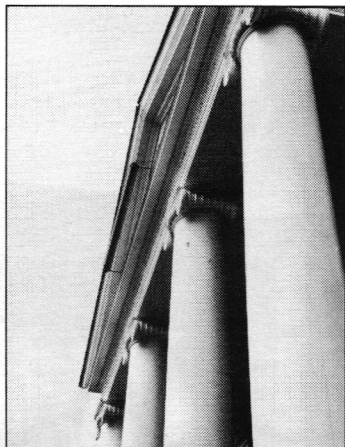

Custom fiberglass architectural manufacturers. All cornice, columns, ornamental railing systems, finials...

Stone or limestone finish.
In-house pattern and tooling facility.
Catalog/Information (215) 943-4567
or FAX (215) 943-4540

WRITE IN NO. 471

**MAKE A
GRAND ENTRANCE**

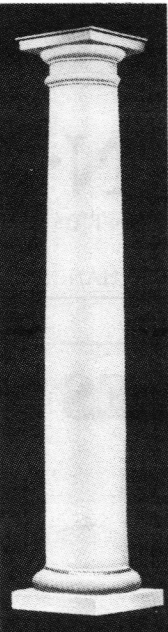

For residential and commercial buildings, we manufacture a wide range of columns from 6 in. dia. in various lengths, to 40 in. dia. and 40 ft. high! We build with the finest North American woods and time-tested joinery. Also stile-and-rail hardwood doors, paneling, mantels, moldings, and custom work.

Call us for more information & pricing.

Somerset Door & Column Co.
Box 328, Somerset, PA 15501
In PA (800) 242-7915
Outside PA (800) 242-7916
Fax (814) 443-1658

WRITE IN NO. 66

**It's Really
BIG!**

**RESTORATION '93
Exhibition
&
Conference**

*The largest preservation
and restoration event
in North America.*

December 6-8, 1993
Hynes Convention Center
Boston, Massachusetts
See page 71 for details

**Why aluminum
columns and
railings are
a smart
investment.**

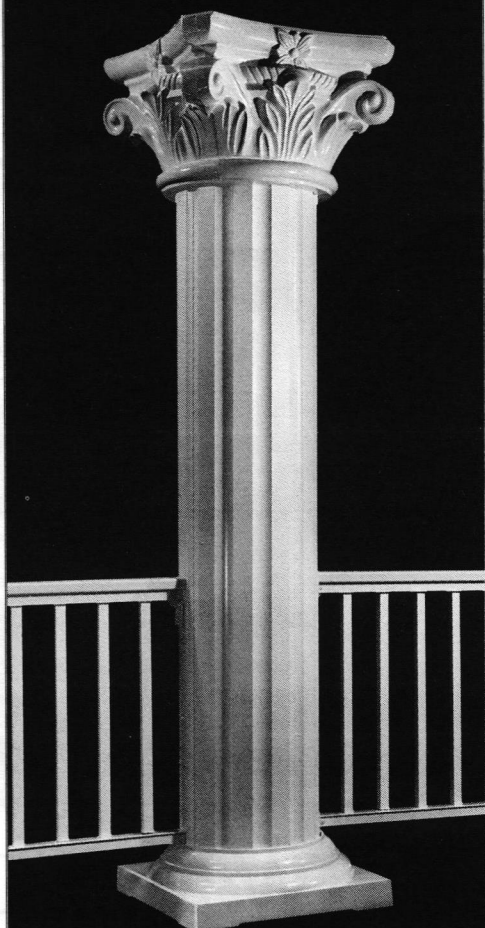

Send for your FREE colorful brochures on easy-to-install no-maintenance columns and strong corrosion-free railings. Styles, sizes, specifications, benefits and the name of your nearest dealer.



ALUMINUM PRODUCTS, INC.

P.O. Box 430
Russia, Ohio 45363
513-526-4065

For more information circle

WRITE IN NO. 70

**CAST ARCHITECTURAL
ELEMENTS**

Custom applications for Hotels, Casinos, Restaurants, and Luxury Homes

- Glass-Reinforced Gypsum (GRG)
- FORTON MG®
- Glass-Reinforced Concrete (GRC)

- Column Covers
- Fireplace Surrounds
- Ceiling Panels • Balustrades
- Mouldings • Domes • Light Coves
- Medallions, etc.

Architectural Products Mfg., Inc.
7470 Greenbrush Ave., N. Hollywood, CA 91605
Tel: (818) 982-2311 FAX: (818) 982-2322

WRITE IN NO. 897

The Right Spot for IN-STOCK...



COLUMNS — The most extensive inventory

Over 150 sizes, styles, shapes and materials for both Interior & Exterior, Structural & Decorative applications.

The Leader in Innovative Plastic Products



OUTWATER
**PLASTICS
INDUSTRIES**
INC.

4 Passaic Street, Wood Ridge, N.J. 07075

For FREE Catalog, Details, Assistance & Prices CALL ...

TOLL FREE: 1-800-631-8375/FAX: 1-800-888-3315

WRITE IN NO. 493

*A designer's vision became a
reality because of DEC's
engineering and experience in a
composite FRP manufacturing.*

At DEC Associates, our staff of over one-hundred fifty skilled craftsmen has built a performance record of unequalled quality.

We put extra care in every phase of activity throughout the entire fabrication process from initial consultation to manufacturing, to inspection and to shipment. Our client list includes some of the nation's leading architects, designers and contractors, therefore we must adhere to consistently high standards on every job.

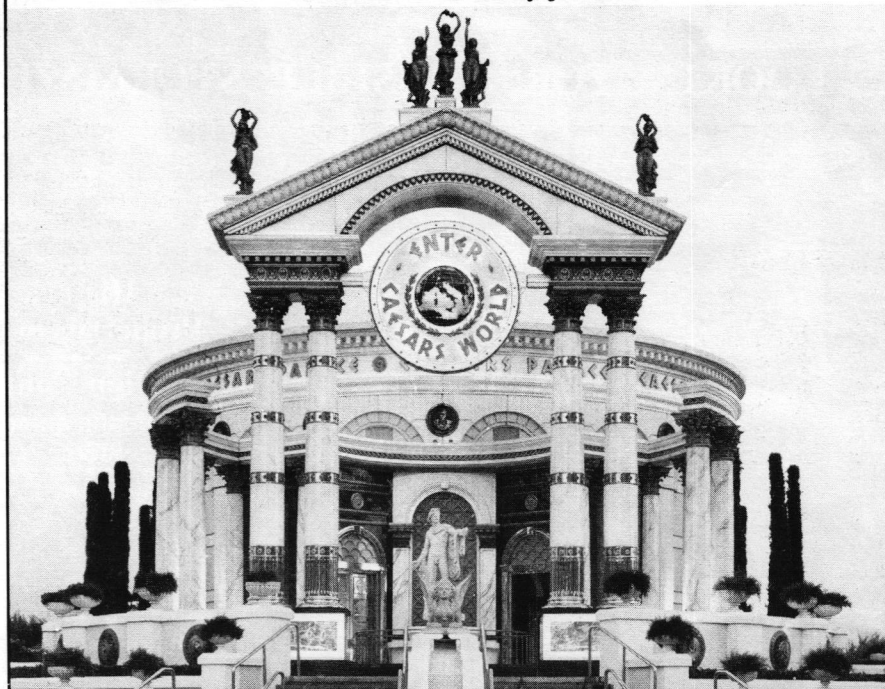

GRG Composite FRP

Cast Stone



1620 S. Sinclair St.
Anaheim, California 92806

ASSOCIATES

(714) 937-0400
FAX (714) 937-0440

WRITE IN NO. 992

Division 7 - MOISTURE PROTECTION



SNOW GUARDS
CAST IN BRONZE

The Most Cost-Effective Solution to Expensive Problems Caused by Winter Snow and Ice Slides

Eagle Design

New Products: Guards for copper & TCS metal panel roofs. Also, new tile-type snowguards.



- Functional and Decorative
- Extremely Durable with bronze and copper construction
- For All Slate Roofing
- Never Any Maintenance

Snow Guards Easily Retrofit To All Existing Roofing

Write or Call for Free Brochure:

M. J. MULLANE CO.

P.O. Box 108 17 Mason St. Hudson, MA 01749
(508) 568-0597 Fax: (508) 568-9227

WRITE IN NO. 56

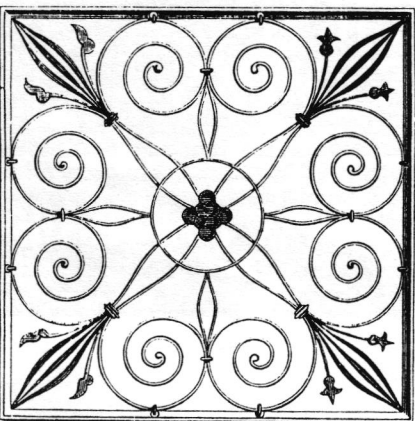

"The Roof That Never Wears Out"
RISING & NELSON SLATE CO., INC.

founded 1869

- Quarriers and producers of natural colored Vermont slate
- Precise control of color & quality
- Almost any quantity or color
- Specialists in Roofing Slate

Box 98, Rt. 153
West Pawlet, Vermont 05775
(800) 348-8820

WRITE IN NO. 286

HISTORICALLY ACCURATE...

...windows and special projects built by quality craftsmen to exacting detail. Competitively priced. Fast turnaround FAX us your specs for a quote.

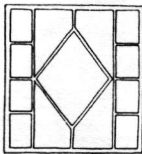

Midwest Wood Products

is now

MIDWEST

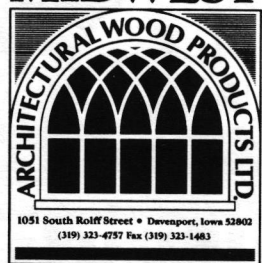

1051 South Rolff Street • Davenport, Iowa 52802
(319) 323-4757 Fax (319) 323-1483

1051 S. Rolff St.
Davenport, IA 52802
319/323-4757
FAX 319/323-1483

WRITE IN NO. 146

Division 8 - DOORS & WINDOWS

TRADITIONAL & CONTEMPORARY WOODEN WINDOWS & DOORS

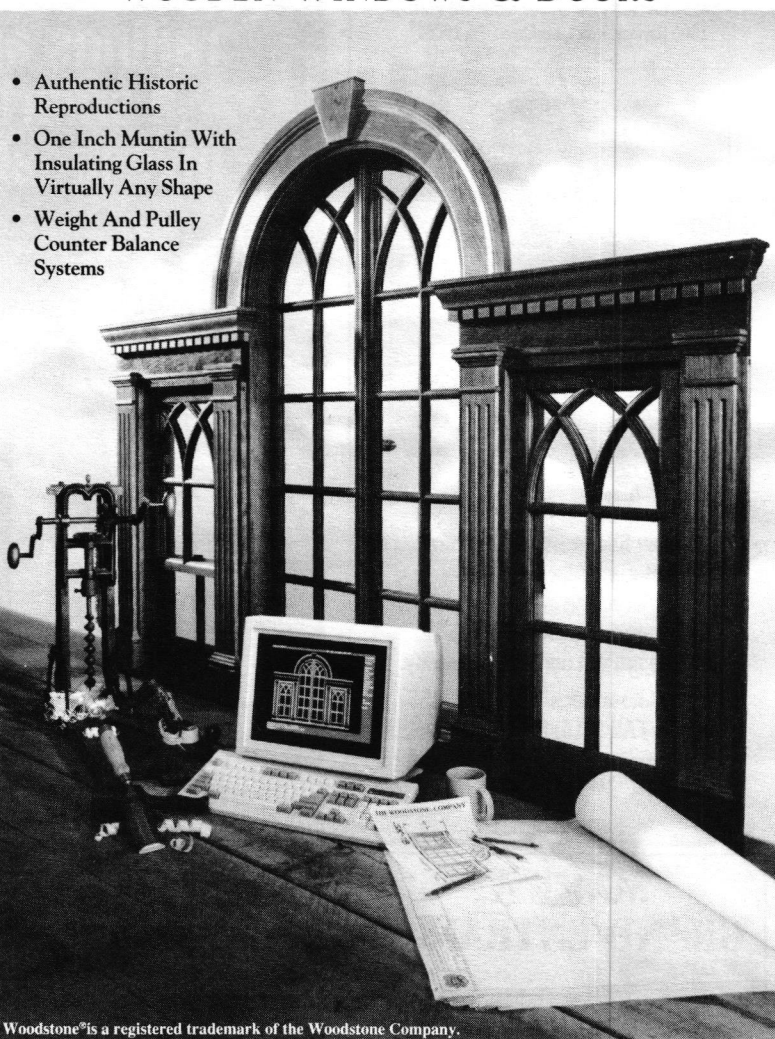

- Authentic Historic Reproductions
- One Inch Muntin With Insulating Glass In Virtually Any Shape
- Weight And Pulley Counter Balance Systems

Woodstone® is a registered trademark of the Woodstone Company.

W·O·O·D·S·T·O·N·E

DEPT T B, BOX 223, WESTMINSTER • VERMONT 05158
(802)722-9217 • FAX(802)722-9528

FOR BROCHURE: PLEASE SEND \$3.00 FOR SHIPPING AND HANDLING

LUDOWICI ROOF TILES

For Sale by Owner of 1992 Renovation

Ludowici Celadon Interlocking 1 1/8" Closed Shingle Tiles
11" long x 8 3/4" wide
Light Brown Tile Body with Matte Green Glaze Spots
Manufactured ca. 1917
Approx. 35-40 Squares Field Tile & Trim Tile Available
Exact Inventory Available Upon Request

Contact: *Tim Jeckering Architects*
4303 Hamilton Avenue, Cincinnati, OH 45223 (513) 542-2500
Ludowici and Celadon are tradenames and/or trademarks associated with Ludowici-Celadon, Inc.

WRITE IN NO. 74

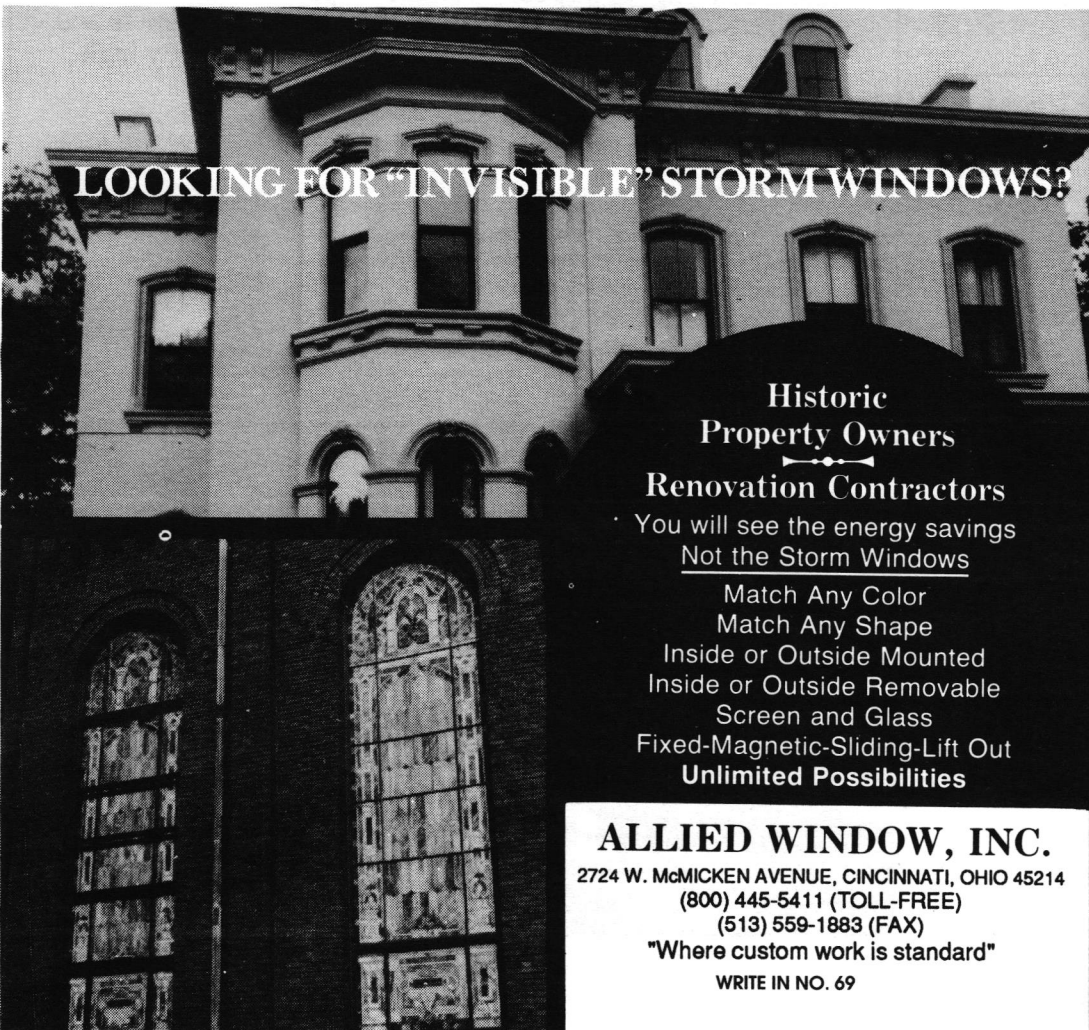

LOOKING FOR "INVISIBLE" STORM WINDOWS?



HERE THEY ARE!

Historic Property Owners

Renovation Contractors

You will see the energy savings
Not the Storm Windows

- Match Any Color
- Match Any Shape
- Inside or Outside Mounted
- Inside or Outside Removable Screen and Glass
- Fixed-Magnetic-Sliding-Lift Out
- Unlimited Possibilities

ALLIED WINDOW, INC.

2724 W. McMICKEN AVENUE, CINCINNATI, OHIO 45214
(800) 445-5411 (TOLL-FREE)
(513) 559-1883 (FAX)

"Where custom work is standard"

WRITE IN NO. 69

Speaking of Victorian Revival . . .

"The raging productivity of the Victorians shattered nerves and punctured stomachs, but it was a thing noble, glorious, awesome in itself." — Elizabeth Hardwick

BY SHARON GARBE

In doing research for this Special Report on Victorian Revival products, we were struck by the astonishing changes that the word "Victorian" has undergone.

Recently recovered from the remainder bin of changing tastes, all things Victorian seem to have reached their apotheosis in the consumer marketplace. Over the past 20 years or so, the word "Victorian" has been transvalued from a derogatory term describing the excrescence of an age considered tasteless, into a descriptor for an exciting historical period. It has also become a successful strategy for marketing all manner of goods, from houses to lingerie.

This new respect has proved a boon for preservation groups and the historical products industry. But in the rush to embrace Victoriana — and cash in on it — the term is at times

applied indiscriminately or erroneously. Some in the industry complain that this misuse is debasing and confusing to the buyer.

Florence Schroeder of Victorian Collectibles, a company which reproduces period wallpapers and fabrics with painstaking accuracy, believes that, along with the miscreants who think "Victorian" is merely a matter of adding ruffles and doilies, are people who are becoming more knowledgeable about period decorating, and are seeking the help of experts — especially in "sympathetic restorations," where property owners who can't afford a true historic restoration opt instead for off-the-shelf reproductions that are historically authentic.

Schroeder notes a growing inclination for people to paper their ceilings. (Though she did cite a number of bloopers, such as a Victoria's Secret store which placed sidewall paper on the ceiling.) The future of the ceiling-paper trend, she believes, is up to architects and builders: If they design 13-ft. ceilings, people have the option of papering them, which they don't with an 8-ft. ceiling.

To Brian Leo of Leo Custom Hardware, "The word Victorian is becoming cumbersome." He sees the

definition being blurred by sellers who confuse the public about quality, design, and historicity, and who make money from alleged Victorian bric-a-brac — like Victorian toast warmers. He believes substituting "look" for "style" would alleviate some of the confusion, but that it is really a "professional duty to inculcate in customers a sensitivity to the subtleties of the Victorian period." Leo notes that within the Victorian time span there were many styles, such as Gothic, Italianate, Eastlake, and Queen Anne, but the styles are not interchangeable simply because they are "Victorian."

Roy Greenstein of Roy Electric Co. has also come up against stylistic lacunae among clients, and finds it can be a touchy situation to correct them. He finds he's supplying a range of customers that starts with a homeowner who "just wants a Victorian fixture," to clients with high-level historic preservation jobs, which requires a keen understanding of developments from one decade to another in Victorian lighting. Roy notes that high-quality lighting reproductions can be better than the originals because they combine new technologies with old styling. His fondest hope: That clients — includ-

ing architects, designers and decorators — should familiarize themselves with the period before shopping. To quote the Victorian designer Christopher Dresser, "Knowledge is Power."

About the SourceList

The Editors surveyed 462 companies for this Victorian Revival Products SourceList, and were pleased by the overwhelming response. On the following pages you will find 135 companies we selected for the diversity of styles and products they offer. Initially, we considered subdividing the SourceList into product categories. But we discovered that many companies have multi-product capabilities, so it seemed we would be needlessly penalizing the reader by artificially pigeonholing the suppliers. ♦

Instant Access to Product Literature for Victorian Products

If your office qualified to receive the 1993 TRADITIONAL BUILDING CATALOG, you'll find prefired product literature there for Victorian Products. Most of the 85 companies represented in the CATALOG's 760 pages have product lines with Victorian styling.

Finely Carved Wood

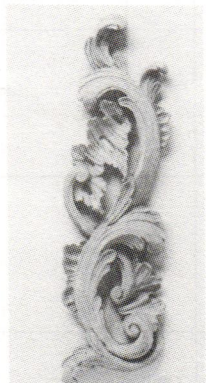

Chippendale
Rococo
Style

We specialize in hand-carved architectural elements, executed to the most discriminating standards.

We have the design & craft skill to execute the ancient Greek, Gothic, Adam and Chippendale styles.

Our work ranges from small detailed carvings to large architectural undertakings including sconces, fireplace mantels, carved doors, panels, mouldings & all manner of decorations.

Macartney Classical Woodcarving
608 Spear Avenue • Duluth, MN 55803
(218) 724-5307

WRITE IN NO. 460

O'Connor's Cypress Woodworks

398 Main Street • P.O. Box 712
Washington, LA 70589
(318) 826-7749



SS48 SLAT SWING

Our products are made from Solid Cypress—a wood long revered by builders and craftsmen everywhere who appreciate beauty and durability. Stained, painted or left to weather to a beautiful brownish grey patina, it will give many years of enjoyment to its owners.

WRITE IN NO. 492



**Country Charm,
Classic Elegance**

Custom Interior
Hardwood Shutters
Victorian Recessed Panels

HISTORIC WINDOWS

P.O. BOX 1172
HARRISONBURG, VA 22801
703-434-5855

Send \$3.00 For Our Brochure
Call For An Appointment
To Visit Our Showroom

WRITE IN NO. 94

*The
Brillion Collection*

Reproductions of
Antique Wallpaper
1850-1910

Victorian Collectibles Ltd. offers authentic reproductions of many wonderful Victorian designs, produced in their original breathtaking colors through modern silkscreen technology. Patterns include swags, cabbage roses, medallions, tulips and stripes, just to name a few. This collection has 1377 different wall, border and ceiling designs, all originally drawn by American artists.

Victorian Collectibles Ltd.
Restoration Professionals of the Victorian Past

845 E. Glenbrook Rd.,
Milwaukee, WI 53217
(414) 352-6971 Fax (414) 352-7290

WRITE IN NO. 525

MORE PLUMBING PRODUCTS FOR THE RENOVATION INDUSTRY THAN FROM ANY OTHER SUPPLIER.



We're nationally known for our wide selection of:

- Brass and Porcelain Fixtures
- Period and Modern styles
- New Footed Tubs
- Specialty Toilets
- Large inventory of parts

CALL TODAY FOR
FREE CATALOG

WORLD CLASS MAIL ORDER

If It's Unique That You Seek, Call A•Ball.

1703 W. Burnside St. • Portland, OR 97209 • Phone (503) 228-0026 • Fax (503) 228-0030

WRITE IN NO. 242

PRICE • QUALITY • DELIVERY
SINCE 1954 • SERVICE



17319 Blaine Drive
Hagerstown, MD 21740
FAX 301-797-2510

ANY PART FOR ANY WINDOW

- THE NATION'S LEADER IN CURRENT & OBSOLETE HARDWARE!
- OVER 40,000 PARTS FOR WINDOWS, DOORS & MORE!
- ANTIQUE REPRODUCTIONS A SPECIALTY!
- FOUNDRY CASTINGS IN RED & NICKEL BRONZE!
- FREE COMPREHENSIVE PARTS CATALOG!

TOLL FREE 1-800-678-1919

WRITE IN NO. 73

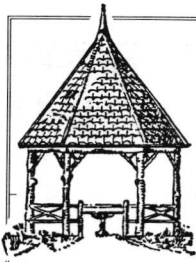

VICTORIAN REVIVAL SourceList

COMPILED BY SHARON GARBE

COMPANY	SPECIALTY	Literature	Metal Ornament	Gingerbread Fretwork Woodwork	Wood & Screen Doors	Hardware	Ceramic Tile	Molded Ornament	Wall Coverings	Art Glass	Plumbing Fixtures & Accessories	Lighting Fixtures	Other	New (N) or Antique (A)
A Carolina Craftsman 975 S. Avocado St., Dept. TB Anaheim, CA 92805 (714) 776-7877	Replacement brass hardware for furniture and houses. Strong emphasis on turn-of-the-century designs. Company sells only from their catalog and has 2,000 items stocked for same-day shipping.	Free brochure <i>Write in No. 424;</i> catalog \$5 (refundable with purchase)	●	●		●					●	●		N
AA-Abbingdon 2149-51 Utica Ave., Dept. TB Brooklyn, NY 11234 (718) 258-8333	Company carries 25 ceiling patterns and 12 cornice styles, available in brass- and copper-plated, mirror or painted finishes.	Free <i>Write in No. 892</i>	●						●					N
A-Ball Plumbing Supply 1703 W. Burnside St., Dept. TB Portland, OR 97209 (503) 228-0026	Mail-order source for everything from porcelain resurfacing kits to showers, corner sinks, pedestal sinks, kitchen faucets, high- and low-tank toilets, clawfoot tubs, and shower curtains.	Free <i>Write in No. 242</i>									●			N
A & M Victorian Decorations 2411 Chico Ave., Dept. TB S. El Monte, CA 91733 (818) 575-0693	Manufacturers of gypsum and precast concrete molded elements such as columns, balustrades, planters, and fountains. Services: Custom work, design, sculpting, mold making, and production.	Free <i>Write in No. 747</i>						●						N
A.N.T. Art Glass P.O. Box 753, Dept. TB Trumansburg, NY 14886 (607) 387-5473	Small studio specializing in beveled glass designs. Custom design and restoration by 3rd generation craftsman. Consultation and installation services.	Free <i>Write in No. 860</i>								●				N
Alloy Casting 3900 Peachtree Rd., Dept. TB Mesquite, TX 75180 (800) 527-1318	Victorian aluminum castings for pickets include steel welding clips cast into the aluminum. Many other stock decorative pieces in catalog; custom capabilities from design through finishing.	Free <i>Write in No. 468</i>	●											N
Amish Country Gazebos 2900 E. Miraloma, Ste. B, Dept. TB Anaheim, CA 92806 (714) 630-3944	Gazebo specialists who feature easy-to-assemble octagonal kits; 8-20 ft. widths; cedar roofing; Victorian or western designs.	Free <i>Write in No. 168</i>											Gazebos	N
Antique Doorknob P.O. Box 483, Dept. TB Cape May, NJ 08204 (609) 884-6282	Architectural antique hardware, lighting, and mantels from early 1800s to early 1900s. Entire door hardware sets, doorbells, hinges, knockers, doorstops, and window products are available. Restores hardware and lighting.	Free <i>Write in No. 426</i>				●						●	Mantels	A
Antique Hardware Store 9730 Easton Rd., Rt. 611, Dept. TB Kintnersville, PA 18930 (215) 847-2447	Wide variety of Victorian home restoration products. Many of the light fixtures are available only through this company.	Free <i>Write in No. 425</i>		●		●			●		●	●		N
Architectural Ceramics 191 W. Olentangy St., Dept. TB P.O. Box D Powell, OH 43206 (614) 889-6370	Hand-made ceramic tiles and other architectural elements. Original and historic reproduction in many styles. Will custom design and manufacture. Also fabricates wash basins, wall sconces, estate numbers.	Free <i>Write in No. 419</i>					●					●		N
Art Directions 6120 Delmar Blvd., Dept. TB St. Louis, MO 63112 (314) 863-1895	Interior lighting fixtures in Victorian and turn-of-the-century styles.	Free <i>Write in No. 436</i>										●		N
Art Glass of the South 2401 Gov't St., Dept. TB Mobile, AL 36606 (205) 479-3392	Custom glass studio; design, fabrication, hand-beveling, and restoration done on premises. Products include windows, decorative glass screens and tables. All work guaranteed.	Free <i>Write in No. 251</i>								●				N
Assn. of Restoration Specialists 122 Clinton St., Dept. TB Hoboken, NJ 07030 (201) 795-1103	Restoration of stained/decorative glass, historic wood windows, and masonry. Offers existing condition surveys, materials specifications, restoration program development, project management, and execution of work.	Free <i>Write in No. 402</i>								●		●	Restoration of glass, wood windows, and masonry	N/A
Ball and Ball Company 463 W. Lincoln Hwy., Dept. TB Exton, PA 19341 (215) 363-7330	The largest supplier of historically accurate builder's hardware from the 18th and 19th centuries. Hand forged, cast, and brass items. Extensive capabilities for custom reproductions and repair of antique hardware.	Free <i>Write in No. 293</i>				●								N
Barker Metalcraft 1701 W. Belmont, Dept. TB Chicago, IL 60657 (312) 248-1115, (800) 397-0129	Manufacturers of a wide variety of custom decorative grills and sheetmetal covers. Six grille patterns, in nickel- or brass-plated finishes, and 7 enamel colors. Suitable for radiator covers, window guards, vents, and grilles.	Free <i>Write in No. 767</i>	●											N
Beech River Mill Co. Old Rt. 16, Dept. TB Center Ossipee, NH 03814 (603) 539-2636	Custom shutters and hardware. Company specializes in duplication and authentic reproduction work.	Free <i>Write in No. 411</i>				●							Shutters	N
Christine Belfor Design Ltd. 177 E. 87 St., Studio 402, Dept. TB New York, NY 10128 (212) 722-5410	Hand-painted ceramic sinks in three styles: Cameo, Garland, and Ornamental Band, with coordinating bath tile. Custom designs welcome.	Free <i>Write in No. 351</i>					●							N

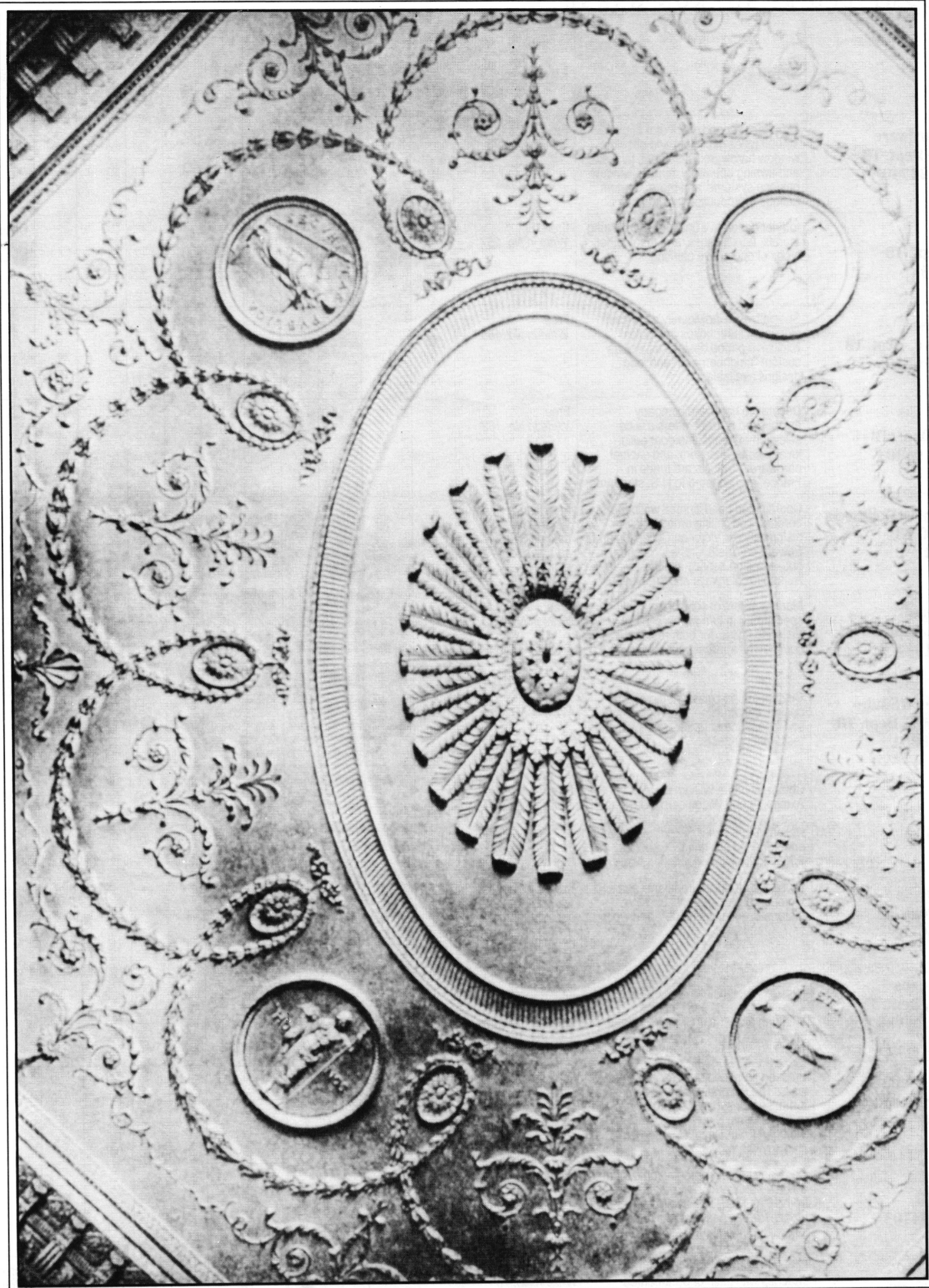

*Ornamental
Compositions*

515 WEST END AVENUE
NEW YORK, NY 10024
PHONE/FAX (212) 799-6337



J.P. Weaver Co.

2301 WEST VICTORY BLVD.
BURBANK, CA 91506
PHONE (818) 841-5700
FAX (818) 841-8462

THE FINEST PERIOD INTERIOR ARCHITECTURAL ORNAMENTATION
CONSULTATION • DESIGN • MATERIALS • INSTALLATION • FINISHING

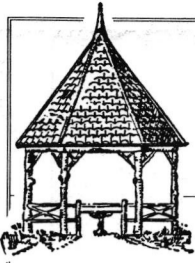

VICTORIAN REVIVAL SourceList

COMPILED BY SHARON GARBE

COMPANY	SPECIALTY	Literature	Metal Ornament	Gingerbread Fretwork Woodwork	Wood & Screen Doors	Hardware	Ceramic Tile	Molded Ornament	Wall Coverings	Art Glass	Plumbing Fixtures & Accessories	Lighting Fixtures	Other	New (N) or Antique (A)
Blaine Window Hardware 17319 Blaine Dr., Dept. TB Hagerstown, MD 21740 (800) 678-1919	Manufacturer and distributor of over 40,000 types of current and obsolete window hardware: Casement, jalousie, and awning operators, hinges, window balance systems, and more. Custom antique reproduction available.	Free Write in No. 73				●								N
BOPAS 30 Ipswich St., Dept. TB Boston, MA 02215 (617) 236-4919	Interior decorative finishes: Marbleizing, murals, faux finishes, and many other types of decorative painting.	Free Write in No. 257						●					Decorative painting and finishes	N
Bose Associates, Inc. 526 Jean Lafitte Ave, Dept. TB Baton Rouge, LA 70810 (504) 751-5701	Specializes in individually sand-cast aluminum letter boxes and poles. Exclusive period designs as well as custom "neighborhood" and logo designs available.	Free Write in No. 488	●											N
Bouvet USA, Inc. 87 Mc Lea Court, Dept. TB San Francisco, CA 94103 (415) 864-0273	Decorative hardware company established in 1884, offers a wide selection of handsome door pulls, levers, bolts, knockers, and cabinet hardware. Products are made in France, and adapted to U.S. standards.	Free Write in No. 162				●								N
Bradbury & Bradbury Art Wallpapers P.O. Box 155, Dept. TB Benicia, CA 94510 (707) 746-1900	Coordinated hand-printed wallpapers, borders, and ceiling ornaments in historic styles: Victorian Collection and Edwardian/Arts & Crafts Collection. In-house design service available. Authentic colorways and adaptations.	Free flyer Write in No. 13; catalog \$10; samples \$.60 - \$1.50							●					N
Brass Reproductions 9711 Canoga Ave., Dept. TB Chatsworth, CA 91311 (818) 709-7844	Manufacturers of solid brass lighting, specializing in turn-of-the-century and Victorian styles, for both residential and commercial applications.	Free Write in No. 622										●		N
Brown's Stained Glass Studio 910 San Francisco St., Dept. TB San Antonio, TX 78201 (512) 734-2653	Custom stained glass studio offers design, construction, and restoration services for commercial, religious, and residential projects.	Free Write in No. 605								●				NA
J.R. Burrows & Co. P.O. Box 522, Dept. TB Rockland, MA 02370 (617) 982-1812	Company offers William Morris, Axminster and Wilton carpet designs. Also, reproduction English Victorian wallpapers, friezes, ceiling papers, and printed fabric designs by Candace Wheeler; design consultation services.	Free Write in No. 693							●				Carpets, fabrics	N
Burton Woodworks 4290 Alalex Rd., Dept. TB Montgomery, AL 36108 (800) 489-0097	Company produces traditional and Victorian-styled turnings, decking materials, and accessories, and wood or PVC lattice.	Free Write in No. 200		●									Turnings, lattice	N
Charles Rupert Designs 2004 Oak Bay Ave., Dept. TB Victoria, B.C., Canada V8R1E4 (604) 592-4916	A small company specializing in reissued designs of historic tiles and wallpaper. Tile designs include Victorian and Arts & Crafts; wallpaper designs are from 1770's to the 1920's.	Sample packs \$5 ea. — specify WP Federal, WP Victorian, WP Arts & Crafts; Tile photos \$5					●		●					N
Chelsea Decorative Metal Co. 9603 Moonlight Dr., Dept. TB Houston, TX 77096 (713) 721-9200	Pressed tin-plated steel for ceilings and walls. The decorative sheets come in 2 X 4 ft. sections, cornices are available in 4 ft. lengths. Styles range from Victorian to Art Deco. Company will ship anywhere.	Free Write in No. 19	●						●					N
Cirecast Inc. 380 7th St., Dept. TB San Francisco, CA 94103 (415) 863-8319	Company makes reproduction door and window hardware using pattern designs from 1870-1885. Pieces are cast in bronze, brass, and aluminum using the lost-wax method.	Free	●			●						●		N
Classic Accents, Inc. P.O. Box 1181, Dept. TB Southgate, MI 48195 (313) 282-5525	Specializes in push-button light switches with plain or ornamented brass, and wooden plates. Also, brass molding hooks, decorative tassels, and carbon filament Victorian bulbs.	Free Write in No. 75				●							Push button switches and plates, molding hooks, light bulbs	N
Classic Architectural Specialties 3223 Canton St., Dept. TB Dallas, TX 75226 (214) 748-1668	Wide selection of period products for interior and exterior renovation and application. Items range from fretwork to Victorian street lamps.	Free Write in No. 904	●	●	●	●		●				●	Benches, fans, mail boxes	N
Classic Illumination, Inc. 2743 Ninth St., Dept. TB Berkeley, CA 94710 (510) 849-1842	Complete line of Victorian chandeliers, wall sconces, and torchieres. Fixtures are authentically handcrafted of solid brass and finished with blown-glass shades. Custom work available; some antique fixtures and glass.	Write in No. 597										●		NA
Classic Lamp Posts 3645 NW 67th St., Dept. TB Miami, FL 33147 (305) 693-4680	Victorian and Colonial street lights, sconces, luminaires, and lighted bollards.	Free Write in No. 429										●		N
Classic Revivals 1 Design Ctr. Pl., Ste. 545, Dept. TB Boston, MA 02210 (617) 574-9030	Company offers accurate reproductions of Victorian wall coverings — documented wallpaper patterns and stamped leathers, carpets, fabrics and lace.	Free Write in No. 610											Carpets, fabrics, lace, wallcoverings	N

CLASSIC
HARDWOOD
REPRODUCTIONS
OF BORDERS
AND FULL ROOM
PATTERNED
FLOORING.
CIRCA
1880-1920.

HISTORIC
FLOORS
OF OSHKOSH
1107 Algoma Boulevard
Oshkosh, WI 54901
(414) 233-5066

CALL OR WRITE FOR
FREE LITERATURE
OR SEND \$25.00
FOR FINISHED
BORDER SAMPLE.

WRITE IN NO. 914

The Nation's Most Complete Collection Of

Architectural Sheet Metal

Decorative Metal Ceiling & Wall Panels

Hi-Art™ Steel Ceiling systems are made using original 80-year-old dies. The Hi-Art™ line includes center plates, corner plates, border plates, cornice and filler plates — permitting classic designs proportioned for an exact fit. Over 140 patterns in either steel or copper.

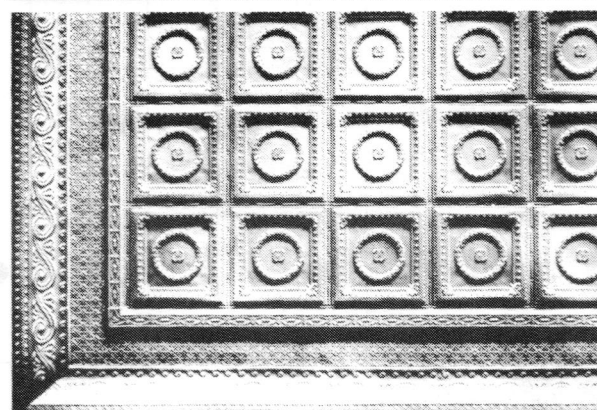
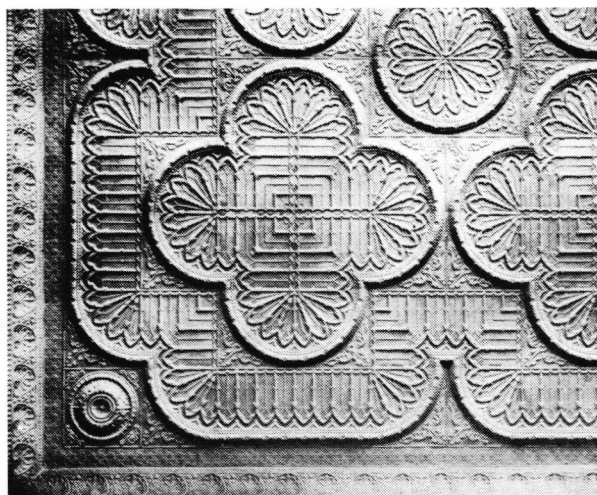

Write for 72-page Sheet Metal Ceiling Catalog.
Or Circle No. 52

Sheet Metal Ornaments

Our 94-year-old line of sheet metal ornament contains over 1,300 items available in zinc or copper.

- ★ Comices ★ Window Hoods ★ Moldings ★ Lintels
- ★ Capitals ★ Brackets ★ Corbels ★ Rosettes
- ★ Balusters ★ Urns ★ Capitals ★ Festoons ★ Finials
- ★ Scrolls ★ Leaves ★ Friezes ★ Canopies
- ★ Marquees ★ Glass pendant frames ★ Cresting
- ★ Garlands ★ Panel Ornaments ★ Lion Heads
- ★ Conductor heads & fittings ★ Weathervanes

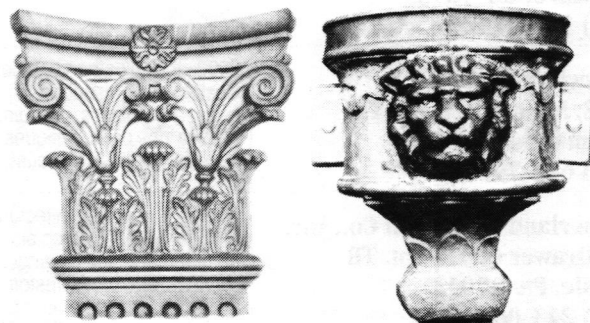

Send for 84-page Sheet Metal Ornament Catalog.

Metal Roofing Shingles

Original 1908 line of metal roofing shingles . . . available in galvanized steel or solid copper. Spanish Tile, Mission Tile, Victorian, and Slate styles. Cresting, finials, and trim also available.

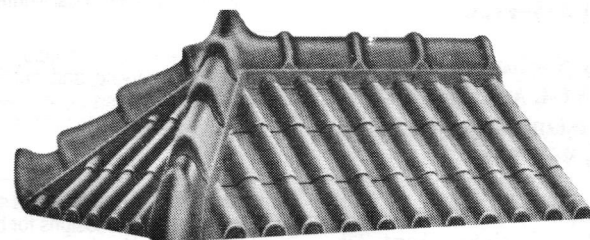

Write for Metal Shingles brochure.

Pressed Metal Siding

Pressed metal siding from turn-of-the-century dies: lightweight, durable, economical. Brick, Rock-Faced Brick, Pitch-Face Stone, and Cluster Shingle.

Write for Pressed Metal Siding brochure.

Custom Reproductions

Our manufacturing process enables us to make reproductions of original panels on a custom basis . . . or to produce your original design. Call us to discuss your needs.

W.F. Norman Corp. P.O. Box 323 Nevada, MO 64772 800-641-4038

WRITE IN NO. 52

EXTERIOR WOOD SHUTTERS



Hard-To-Find Wood Shutters with moveable louvers can be used outdoors or in. Fixed louver, raised panel, and custom arches also available. Order unfinished or primed and painted. Hinges and holdbacks shipped daily by UPS.

Brochure: (203) 453-1973
SHUTTERCRAFT 282 Stepstone Hill
Guilford, Conn. 06437

WRITE IN NO. 44

Your Award-Winning Source for Elegant Woodwork



Everything you need in Victorian gingerbread, turnings and carvings, in premium grade solid hardwoods. Factory-direct savings.

Period bars, Backbars, Servers, Ceilings, Seating, Gazebo Kits and accessories.

We'll build to your specifications, supply any or all component parts. Complete custom design services.

Interior/exterior restoration projects, Victorian to Ultra-Contemporary, our specialty.

Send for catalog. Over 180 color pictures of products and design ideas. \$5.00. Free if ordered on Company letterhead.

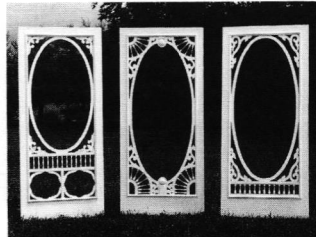

Office hrs. 8 AM to 4 PM Mon.-Fri. EST

Post Office Drawer 609 Carlisle, PA 17013 Dept. 222
(717) 243-0063 (800) 367-1884 Outside PA FAX (717) 243-6502

WRITE IN NO. 131

BACK BY POPULAR DEMAND!

Classic Pedestal Sinks ~ \$225*



While supplies last, these fine quality vitreous china pedestal sinks represent an outstanding value for restoration or new construction projects.

Mention this ad and save 25% off coordinating faucets, fittings, and bath accessories, when purchased along with this sink.

Please refer to offer TB-793 when placing your order.

*Model PDS-400A
Some pieces may have minor blemishes. Prices do not include shipping and handling charges.

HARDWARE+Plus, Inc.
1-800-522-7336

We accept Mastercard, Visa, & Discover.

WRITE IN NO. 652

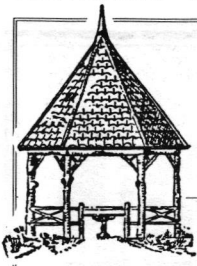

VICTORIAN REVIVAL SourceList

COMPILED BY SHARON GARBE

COMPANY	SPECIALTY	Literature	Metal Ornament	Gingerbread Fretwork Woodwork	Wood & Screen Doors	Hardware	Ceramic Tile	Molded Ornament	Wall Coverings	Art Glass	Plumbing Fixtures & Accessories	Lighting Fixtures	Other	New (N) or Antique (A)
Conant Custom Brass, Inc. 270 Pine St., Dept. TB Burlington, VT 05401 (802) 658-4482	Manufacturers of decorative metal products for Victorian homes. Solid brass outdoor thermometers and dust corners are among the products offered. Custom lighting commissions are the company's specialty.	Free Write in No. 62				●					●	●	Outdoor and indoor table thermometers, dust corners	N
Coppa Woodworking 1231 Paraiso Ave., Dept. TB San Pedro, CA 90731 (310) 548-4142	Carries 90 styles of wood doors in variety of thicknesses. Species include pine, Douglas fir, mahogany, and oak. All sizes and finishes; arched tops available.	Free Write in No. 960			●									N
Crosswinds Gallery 980 E. Main Rd., Dept. TB Portsmouth, RI 02871 (401) 683-7974	3000 stock weathervane designs. Custom design specialists; all types, sizes, and finishes, including gilding. Also carries parts, antiques, and large selection of stock and custom cupolas.	Free Write in No. 263	●										Weathervanes, cupolas	N/A
Cumberland Woodcraft Co., Inc. P.O. Drawer 609, Dept. TB Carlisle, PA 17013 (717) 243-0063	Complete line of architectural and period millwork fixtures and decorative treatments, including gingerbread, carvings, and bars. Custom work available.	Free Write in No. 131		●	●			●	●	●			Bars, back-bars, gazebos	N
Cummings Studios P.O. Box 427, Dept. TB North Adams, MA 01247 (413) 664-6478	Large art glass studio with experience in commercial, civic, and religious projects. Services: Project development and management, conservation/restoration, design, fabrication, and installation.	Free Write in No. 316								●				N
D.E.A. Bathroom Machineries P.O. Box 1020, Dept. TB Murphys, CA 95247 (800) 255-4426	Catalog features clawfoot tubs, pedestal sinks, faucets, and other period bathroom appurtenances. Also offers restoration services for plumbing, lighting, and electrical fixtures.	Free Write in No. 586				●					●	●	Scales	N
D.M.S. Studios 5-50 51st. Ave., Dept. TB Long Island City, NY 11101 (718) 937-5648	Versatile sculpture studio is skilled in smithing, carving, and molding, with a special emphasis on the reproduction of historically-styled items.	Free Write in No. 910	●					●					Carved stone sculpture and architectural elements	N
J. A. Dawley 6 W. Elizabeth St., Dept. TB Waterloo, NY 13165 (315) 539-5046	Architectural woodworkers specializing in Victorian era designs for both interior, exterior, and landscape applications. Custom work, including new designs and replication, is available in small and large quantities.	Free Write in No. 420		●	●									N
Decorators Supply Co. 3610-12 S. Morgan St., Dept. TB Chicago, IL 60609 (312) 847-6300	Wide selection of period architectural molded ornament, from ceiling medallions to columns and capitals in Plaster of Paris and composition.	Free						●						N
Denninger Cupolas & Weathervanes RD1 Box 447, Dept. TB Middletown, NY 10940 (914) 343-2229	This company's banners, fancy arrows, caps, and finials are inspired by the work of Victorian artisans such as Jewell, Westervelt, and Fiske.	Free Write in No. 730	●										Cupolas, weathervanes	N
Designs In Tile P.O. Box 358, Dept. TB Mt. Shasta, CA 96067 (916) 926-2629	Custom hand-decorated ceramic tiles and murals. Victorian Revival products: Anglo-Japanese, Neo-Grec, Gothic Revival, and Victorian Foliate tiles, borders, panels, corner blocks, mosaic floors, molded wainscapes, and 3 X 6 in. tiles.	Free Write in No. 25					●							N
Raymond Enkeboll Designs 16506 Avalon Blvd., Dept. TB Carson, CA 90746 (310) 532-1400	Large selection of ornately carved architectural millwork, such as panels, moldings, mantels, newels, corbels, rosettes, and finials.	Free Write in No. 577		●										N
Larry Etzen P.O. Box 22384, Dept. TB Kansas City, MO 64113 (816) 363-5980	Fabrication of large architectural leaded glass light fixtures, large-scaled domed, flat, or arched leaded-stained glass ceilings, all types of art glass windows, and small Tiffany-style lamps.	Free								●		●		N
Eugenia's Place 3522 Broad St., Dept. TB Chamblee (Atlanta), GA 30341 (404) 458-1677	Supplier of antique hardware such as curtain tie-backs, door knockers & hardware, furniture hardware, and twist bells.	Free Write in No. 431				●								A
Ewing Restoration 418 N. Marshall St., Dept. TB Graham, NC 27253 (919) 228-8022	This shop specializes in restoration, preservation, and installation of many forms of specialized plaster finishes using historically accurate methods and materials.	Free Write in No. 238						●						N
Faux Effects 1613 10th Ave., Dept. TB Vero Beach, FL 32960 (407) 778-9044	Manufacturer and supplier of decorative and faux finishing products. Designer and architectural finishes from Old World to contemporary. Company also offers professional classes.	Free Write in No. 469											Decorative & faux finishes, products, & classes	N
Fe Fi Faux 337 S. Davie St., Dept. TB Greensboro, NC 27401 (919) 272-3289	Specializes in courses and workshops for both novices and professionals on the creation of all the traditional faux finishes: Marbleizing, wood graining, wall glazing, and fantasy finishes.	Free Write in No. 449											Decorative finishes, workshops	N

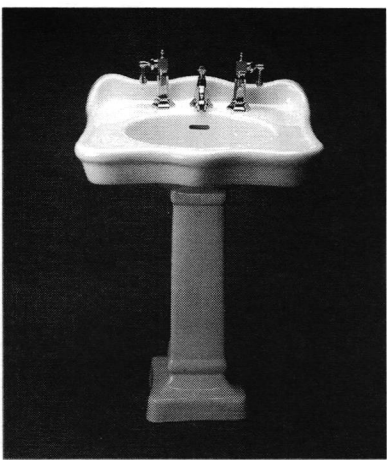

No. 704 Nouveau lavatory shown above with the No. 144 Deco faucet.



No. 805 Slipper tub shown above with the No. 423 handshower/tubfill unit. Tub is available with brass, chrome or white porcelain feet.

NOTE: All Sunrise faucets are available in powder-coated solid brass, uncoated solid brass and chrome plate. Any handles may be used with any faucet.



No. 403 Classic tubfill, below. ↓



No. 121 Widespread faucet, above.

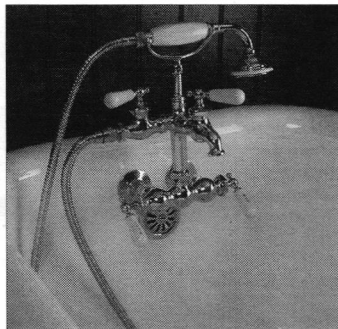

No. 413 solid brass tubfill/hand-shower with 60" hose, shown at left. ←

No. 811 Classic tub with solid oak ring, No. 424 tubfill/shower fitting and shower curtain ring, shown at left. ←

No. 401 In-wall shower/tubfill with center diverter shown and No.18 cross handles, right. →

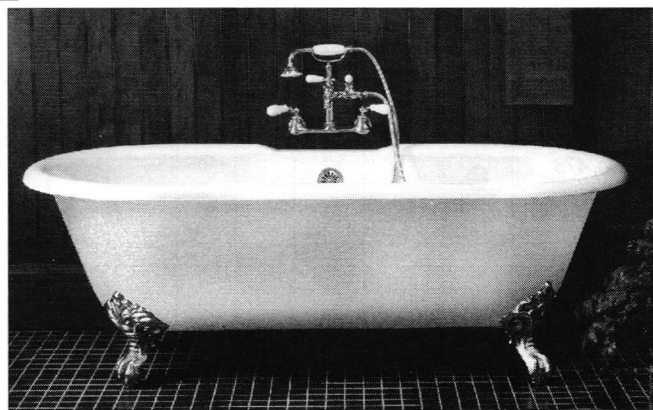
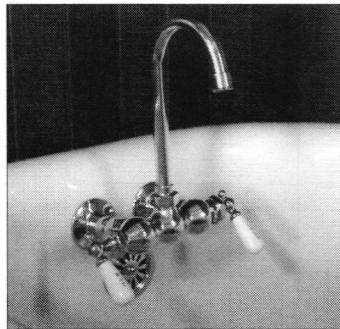

No. 806 double ended tub, shown at left with solid brass feet.

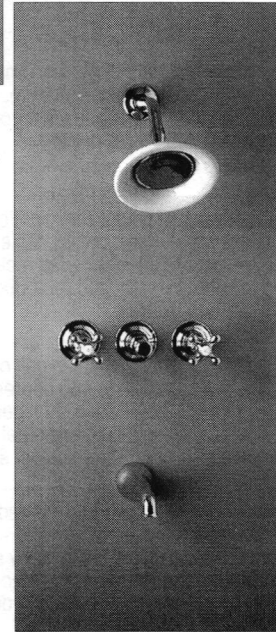

No. 901 Classic Victorian Pull-chain Toilet above, with solid oak seat and tank.

SUNRISE SPECIALTY CO.

5540 Doyle Street, Emeryville
California 94608
Phone: 510-654-1794
FAX 510-654-5775

WRITE IN NO. 464

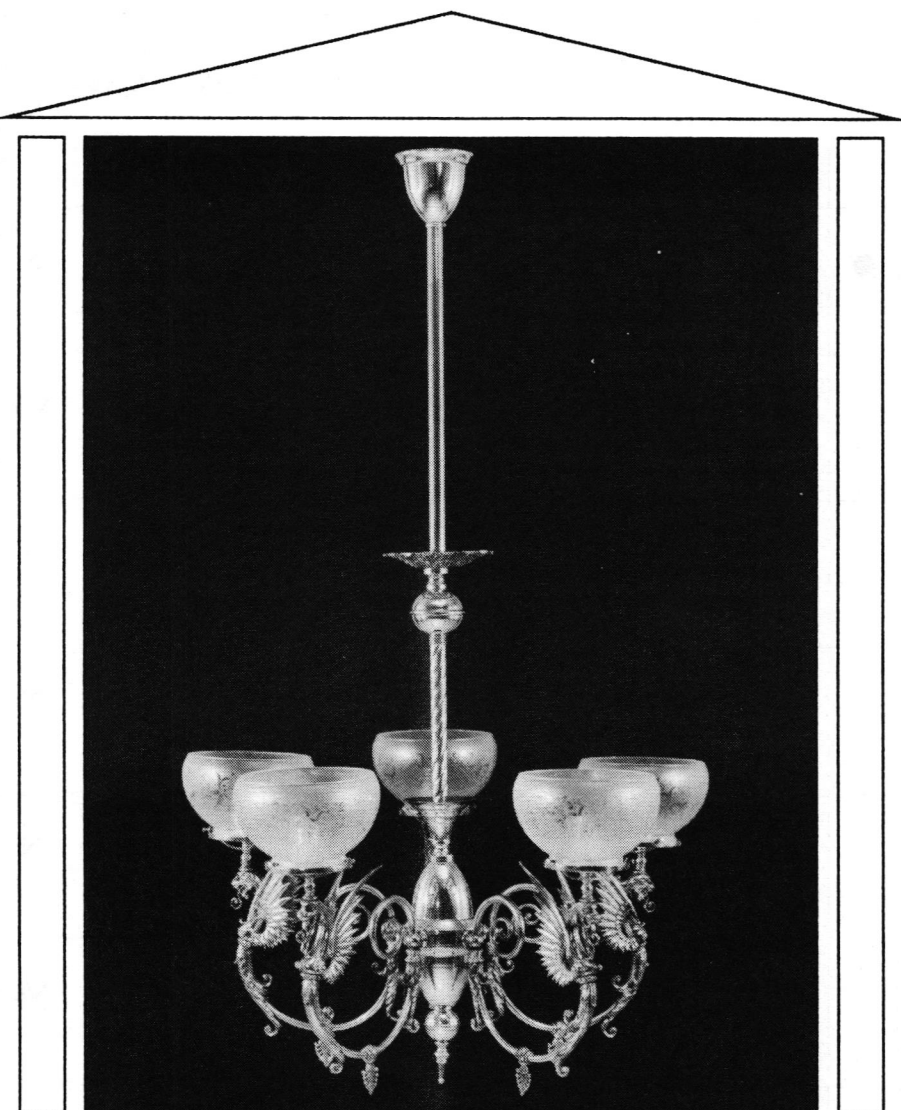

Classic Illumination Inc.

(510) 849-1842 FAX (510) 849-2328
2743 Ninth Street, Berkeley, CA 94710

WRITE IN NO. 597

ANDREAS LEHMANN FINE GLASSWORK

Andreas Lehmann produces custom designed glasswork for interiors and architecture. Born and trained in Germany, he uses a technique called "cutglass" which is commonly known as cut crystal.

Mr. Lehmann also is an expert in reproducing Victorian wheel-cut designs.

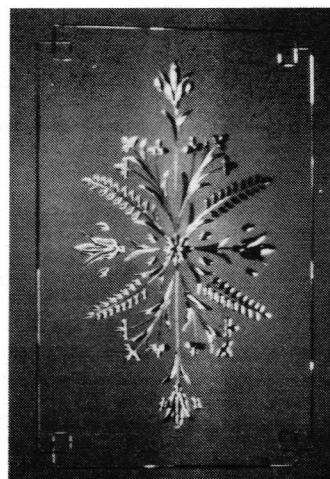
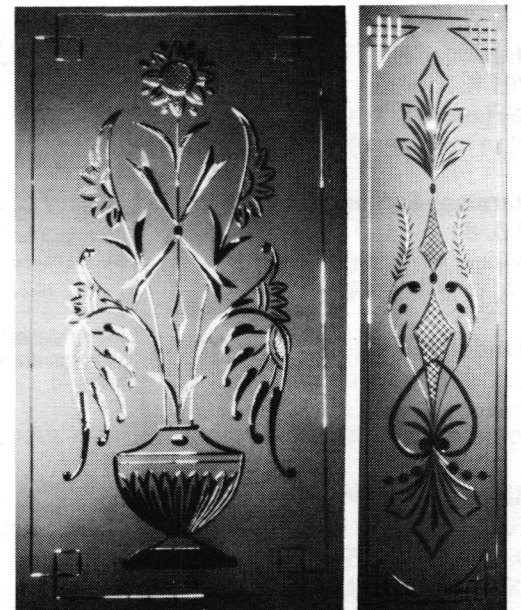

The brilliance in cutglass is achieved when light travels through the polished cuts and creates prismatic and optical effects.

FREE ESTIMATES AND BROCHURE ON REQUEST.

1793 12TH STREET
OAKLAND, CA 94607
PHONE & FAX: 510-465-7158

WRITE IN NO. 473

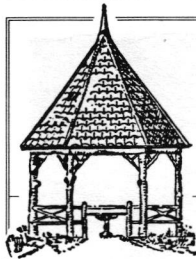

VICTORIAN REVIVAL SourceList

COMPILED BY SHARON GARBE

COMPANY	SPECIALTY	Literature	Metal Ornament	Gingerbread Fretwork Woodwork	Wood & Screen Doors	Hardware	Ceramic Tile	Molded Ornament	Wall Coverings	Art Glass	Plumbing Fixtures & Accessories	Lighting Fixtures	Other	New (N) or Antique (A)
Felber Ornamental Plastering Corp. P.O. Box 509, Dept. TB Ardmore, PA 19003 (800) 392-6896	Architectural plaster studio specializing in historic restoration and fabrication of ornaments in plaster, GRG, GFRC, FRP, and polymer-modified gypsum.	Free Write in No. 289						●						N
Fischer & Jirouch Co. 4821 Superior Ave., Dept. TB Cleveland, OH 44103 (216) 361-3840	Ornamental plaster elements for wall decoration, ceiling and chandelier enhancement, and specific period looks.	Free Write in No. 196						●						N
Fischer Artworks 6530 S. Windermere, Dept. TB Littleton, CO 80120 (303) 798-4841	Custom weathervanes and lightning rods. Designs include Victorian banners and vanes with colored glass inserts. Sealed bearing or teflon bushings are used.	Free Write in No. 172	●										Weathervanes, lightning rods	N
Florentine Craftsmen 46-24 28th St., Dept. TB Long Island City, NY 11101 (718) 937-7632	Manufacturers of garden ornaments, statuary, fountains, furniture, and accessories in stone, cast iron, lead, aluminum, and bronze.	Free Write in No. 439	●									●	Garden ornaments and furniture	N
Gibson & Gibson Antique Lighting 180 Mace #C9, Dept. TB Chula Vista, CA 91911 (619) 422-2447	Company specializes in antique lighting fixtures — floor, ceiling, table, and wall — from 1889-1990. Also repairs and rewires fixtures, and reproduces antique fixtures.	Free										●		A
Goddard Manufacturing P.O. Box 502, Dept. TB Logan, KS 67646 (913) 689-4341	Makes circular stairs in oak or pine, with turns of 90 to 180 degrees. Base price is \$3,500. Also, all types of wrought iron railing and steel spiral stairs. Products are custom sized.	Free Write in No. 478	●										Circular stairs	N
Golden Age Glassworks 339 Bellvale Rd., Dept. TB Warwick, NY 10990 (914) 986-1487	Produces leaded and stained glass windows, lampshades, and architectural pieces in many styles. Restoration experience. Also carries antique glass windows and doors; framing available.	Free Write in No. 28			●					●		●		N, A
Granite Lake Pottery, Inc. P.O. Box 236, Rt. 9, Dept. TB Munsonville, NH 03457 (800) 443-9908	Hand-thrown stoneware sinks ranging in size from 10 to 20 inches, each individually decorated. Matching tiles and bath accessories are available.	Free					●						Stoneware sinks	N
Green Enterprizes 43 South Rogers St., Dept. TB Hamilton, VA 22068 (703) 338-3606	Company specializes in Victorian furniture such as swings, gliders, tables, and bench sets.	Free Write in No. 966											Outdoor furniture	N
Hardware Plus 701 E. Kingsley Rd., Dept. TB Garland, TX 75041 (214) 271-0319	Specialists in Vintage hardware, plumbing, architectural detailing, and accessories.	Free brochure Write in No. 652; Binder \$15	●	●		●		●	●		●	●		N
Harmony Exchange P.O. Box 843, Dept. TB Boone, NC 28607 (704) 264-2314	Company offers a full line of unfinished and pre-finished hardwood flooring, interior solid wood paneling, wood shingles and shakes.	Free							●				Flooring, paneling, Shakes & shingles	N, A
Randolph Herr, Inc., Dept. TB 111-07 77th Ave., Dept. TB Forest Hills, NY 11375 (718) 520-1443	Player pianos! As well as other Victorian-era pianos, restored, bought, and sold.	Free											Player and regular pianos	A
Hinges & Handles 100 Lincolnway East, Dept. TB Osceola, IN 46561 (800) 533-4782, (219) 674-8878	Wide selection of door hardware in period styles. Handles and levers are available in porcelain, brass, and crystal.	Free Write in No. 948				●								N
Historic Floors of Oshkosh P.O. Box 572, Dept. TB Oshkosh, WI 54902 (414) 233-5066	Manufacturer of 5/16 in. parquet, borders, and medallions in hardwood for the flooring industry. The patterns are exact reproductions of turn-of-the-century designs.	Free Write in No. 914		●										N
Historic Shutter & Restoration 5700 4th Ave., Dept. TB Key West, FL 33040 (305) 296-6332	Expert restorers and custom builders of traditional window and door shutters. All periods and styles. Solid brass screw eyes; hand-cut pegs. Decorative hardware; product samples available.	Free Write in No. 85											Wood shutters	N/A
Historic Windows P.O. Box 1172, Dept. TB Harrisonburg, VA 22801 (703) 434-5855	Custom interior hardwood shutters.	Free Write in No. 94											Shutters	N
Historical Arts & Casting, Inc. 5580 W. Bagley Pk. Rd., Dept. TB West Jordan, UT 84088 (801) 569-2400	Cast-metal architectural ornamentation specialists and restoration experts. Designs, manufactures, and installs a wide range of period interior and exterior architectural and landscape products.	Free Write in No. 121	●		●	●						●		N

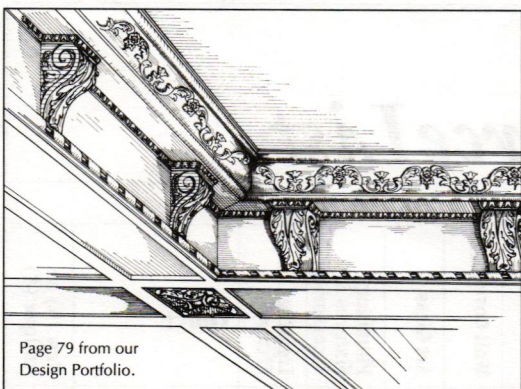

Page 79 from our Design Portfolio.

Our 66 page color **Product Catalog** shows **380** carvings, finely crafted in oak and maple covering a broad range of design selections.

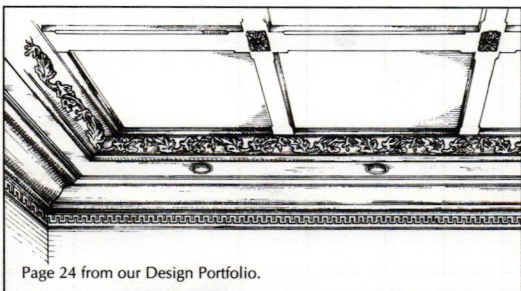

Page 24 from our Design Portfolio.



Quality,
Tradition,
— and —
Elegance.

Page 32 from our Design Portfolio.

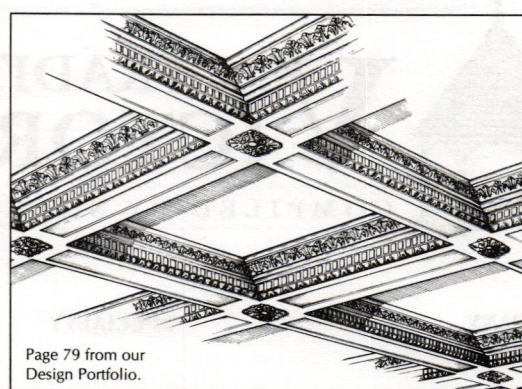

Page 79 from our Design Portfolio.

The 88 page **Design Portfolio** keyed to the Product Catalog, shows traditional and innovative designs.

Raymond Enkeboll Designs
ARCHITECTURAL WOODCARVINGS

16506 Avalon Boulevard, Dept. TB8
Carson, California 90746

Tel: (310) 532-1400 Fax: (310) 532-2042

Product Catalog & Design Portfolio Set, \$20.
For free brochure, write in number.

WRITE IN NO. 577

ELEGANCE IN PORCELAIN AND BRASS WITH A TOUCH OF THE PAST

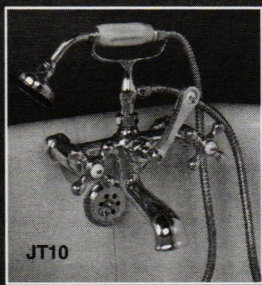
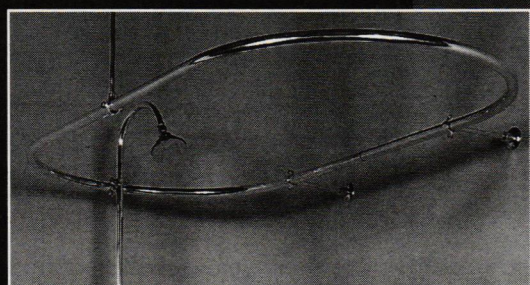

JT10

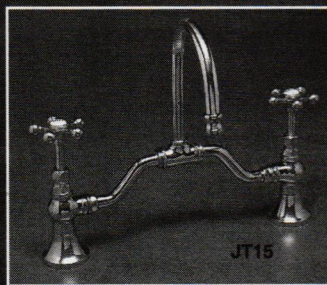

JT15



JT12

PEDESTAL SINKS, TUBS, SHOWER SYSTEMS, ACCESSORIES, & MORE!

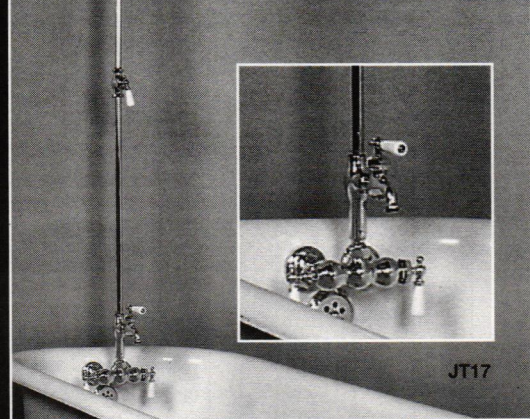

JT17



JT14

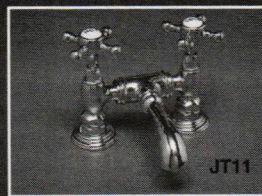

JT11

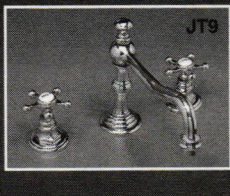

JT9



V-166

Complete catalog of
Victorian & Traditional
plumbing products.

Over 80 pages of fine
quality designer
bathroom fixtures and
fittings at your fingertips.
\$5 refundable w/purchase.
Free Information!

Ask us about custom
designed faucets and
fittings for bathrooms
and kitchens.

JT INTERNATIONAL

83 E. Water Street, Rockland MA 02370

1-800-959-4808
1-617-335-2445

WRITE IN NO. 243

**1893-1993
CELEBRATING
100 YEARS!**

WOOD MANTLES
CAPITALS
BRACKETS
MEDALLIONS
PLASTER CORNICES
WOOD MOULDINGS
COMPOSITION & WOOD FIBER ORNAMENTS

Established 1893
DECORATORS SUPPLY CORPORATION
3610 S. MORGAN ST., DEPT. TB • CHICAGO, IL 60609
312/847-6300

**VICTORIAN
WALLPAPERS**

- Handprinted Borders, Friezes, Ceiling Papers & Coordinated Wall Fills.
- Available Directly from our Studio by Mail Order.
- In-house Design Service.
- Color Catalog with Binder: \$10.00

**BRADBURY & BRADBURY
ART WALLPAPERS**
P.O. BOX 155-L • BENICIA, CA. 94510
(707) 746-1900

**NOW AVAILABLE!
Edwardian / Arts & Crafts
Collection
Call for Details**

WRITE IN NO. 13

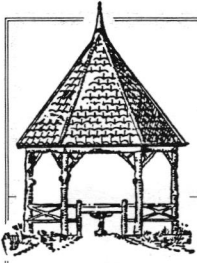

TRADITIONAL BUILDING's VICTORIAN REVIVAL SourceList

COMPILED BY SHARON GARBE

COMPANY	SPECIALTY	Literature	Metal Ornament	Gingerbread Fretwork Woodwork	Wood & Screen Doors	Hardware	Ceramic Tile	Molded Ornament	Wall Coverings	Art Glass	Plumbing Fixtures & Accessories	Lighting Fixtures	Other	New (N) or Antique (A)	
House of Moulding 15202 Oxnard St., Dept. TB Van Nuys, CA 91411 (818) 781-5300	Wide selection of moldings, turnings, and carvings, hardwood plaques, plinth blocks, and finials. Also offers complete millwork package.	Free Write in No. 230		●										N	
J.T. International 83 East Water St., Dept. TB Rockland, MA 02370 (617) 288-0516	Reproduction Victorian & traditional faucets, shower systems, and pedestal sinks.	Free Write in No. 243									●			N	
Jefferson Art Lighting P.O. Box 7997, Dept. TB Ann Arbor, MI 48107 (313) 761-8160	Designs and fabricates original lighting fixtures in historically accurate styles, for residential, commercial, and civic buildings. Also restores antique fixtures.	Free Write in No. 470										●		N	
Jefferson Art Studio 4371 Lima Center Rd., Dept. TB Ann Arbor, MI 48103 (313) 428-8861	Offers Lithophanes (porcelain transparencies) of Victorian images, available as night lights, lamps, sun catchers and shades for oil lamps and chandeliers. Custom wall sconce panels.	Free Write in No. 472										●	Lithophanes	N	
H&R Johnson 190 Highway 18, Dept. TB East Brunswick, NJ 08816 (908) 545-9161	Minton Hollins collection of ceramic tiles and profiled pieces; Maw & Co. ceramic pieces, such as vases, lamps, mirrors, trays, etc., designed to complement Minton wall tiles. Also, encaustic and geometric floor tiles.	Free Write in No. 568					●					●	Jardinieres, trinket boxes, trays, mirrors	N	
Kestrel Manufacturing P.O. Box 12, Dept. TB St. Peters, PA 19470 (215) 286-5341	Reproduction shutters custom made to size, in both operable louver and raised-panel designs. All shutters are supplied with solid brass English hardware. Also, operable louver screen doors.	Free Write in No. 799			●								Shutters, jardiniere, plant stands	N	
King's Chandelier Co. P.O. Box 667, Dept. TB Eden, NC 27288 (919) 623-6188	Design-manufacturers of polished solid-brass Victorian chandeliers and sconces with Venetian crystals. Also, traditional 18th- and 19th-century, all-crystal chandeliers and sconces, hung with Austrian Swarovsky Strass crystals.	Catalog \$3.50										●		N	
Knobs N' Knockers Peddlers Village, Dept. TB Lahaska, PA 18931 (215) 794-8045	This company has an extensive collection of Victorian and traditional door and cabinet fittings for residential use. In addition, it carries bathroom fixtures, weathervanes, and wrought iron hardware.	Free Write in No. 775				●					●		Cabinet, shutter, & door hardware, knockers, locks, registers, fireplace accessories	N	
J & R Lamb Studios, Inc. P.O. Box 291, Dept. TB Philmont, NY 12565 (518) 672-7267	This studio, founded in 1857, offers duplication and restoration of art-glass skylights, side lights, transoms, and windows. Also, restoration of canvas and ornamental plaster.	Free								●			Restoration of painted canvas and ornamental plaster	A	
Lampshades of Antique P.O. Box 2, Dept. TB Medford, OR 97501 (503) 826-9737	Victorian fringe fabric lamp shades designed, manufactured, and restored. Extensive inventory of new and vintage fringe, fabric, and trim in stock, in any color.	Free brochure Write in No. 275; catalog \$4										●	Lamp shades, tassels	N, A	
Langhorne Carpet Co. 201 W. Lincoln Hwy., Dept. TB Pennel, PA 19047 (215) 757-5155	Manufacturer of Jacquard Wilton reproduction woven carpets. Produces broad seamless carpets, and operates looms (identical to those used in the Victorian period) built to weave Wilton carpets in 27 in. widths.	Free											Carpets	N	
Lehmann Studios 1793 12th St., Dept. TB Oakland, CA 94607 (510) 465-7158	Custom wheel-cut art glass for residential and commercial interiors.	Free Write in No. 473								●				N	
Leo Custom Hardware 7532 Columbus Ave.S., Dept. TB Richfield, MN 55423 (612) 861-1473	Fabricates custom castings (investment and sand cast) for grilles, screens, door hardware, finials, knockers, and other hardware and interior metalwork. Existing patterns and molds on hand, or will custom-produce.	Free Write in No. 584	●			●								N	
Kenneth Lynch & Sons 84 Danbury Rd., Box 488, Dept. TB Wilton, CT 06897 (203) 762-8363	Top-of-the-line fabricators with an extensive catalog of garden ornaments, site furniture, weather vanes, gazebos, fountains, and more, in cast and natural stone, bronze, and lead.	Free	●											Statuary, fountains, benches, street clocks	N
Mac the Antique Plumber, Inc. 885 57th St., Dept. TB Sacramento, CA 95819 (916) 454-4507	The 96-pg., 4-color catalog includes bathroom suites, tubs, showers, sinks, faucet sets, re-finished antique cast-iron tubs, accessories, hardware, lighting, more.	Free brochure Write in No. 813; Send \$6 for catalog, refundable on \$25 order				●					●	●		N/A	
Macartney Classical Woodcarving 608 Spear Ave., Dept. TB Duluth, MN 55803 (218) 724-5307	All styles of carved moldings, doors, frames, mantels, and other interior architectural elements, as well as furniture.	Free Write in No. 460		●									Furniture	N	
Mad River Woodworks P.O. Box 1067, Dept. TB Blue Lake, CA 95525 (707) 668-5671	Produces full line of Victorian millwork and turned products, including gingerbread, balusters, finials, corbels, moldings, and screen doors.	Free flyer Write in No. 035; brochure \$3		●	●									N	

RESTORATION HARDWARE

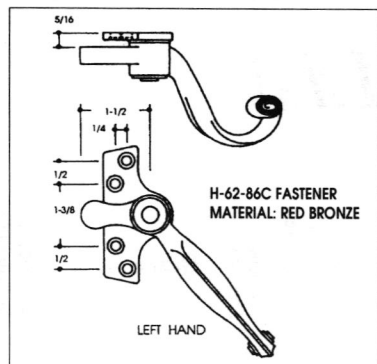

- Milford Replacement Hardware supplies a wide variety of "Restoration Hardware" with emphasis on window hardware.
- We carry Hopes, Ives and imported English window hardware in bronze and brass.
- Unique items can be reproduced using the lost-wax process.
- We also do custom work.

Call for more information:

MILFORD REPLACEMENT HARDWARE
73 Ruth Ann Terrace Milford, CT 06460
(203) 877-0606 800-758-6602
FAX (203) 874-4097

WRITE IN NO. 491

BRING BACK THE LOOK OF THE 1890's IN THE 1990's



NEW VICTORIAN DESIGNS

CHELSEA DECORATIVE METAL CO.

9603 Moonlight Dr., Dept. TB6
Houston, Texas 77096

(713) 721-9200

CATALOGS \$1.00

WRITE IN NO. 19

Gate Hardware

Your Source for Traditional Gate, Barn and Stable Hinges

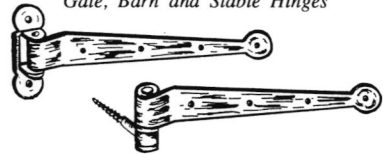

James Peters & Son, Inc.
MANUFACTURERS OF HARDWARE

1936 North Front Street • Philadelphia, PA 19122
Phone: 215-739-9500 Fax: 215-739-9779
Sold through hardware distributors

WRITE IN NO. 124

CUSTOM STONE FOR KITCHEN & BATH

Countertops • Tabletops • Sinks
Stone Furniture • Custom Installations
Finest craftsmanship

Marble, granite, and stone fabricated to your specifications. Affordable prices. Call for quote.

D-M-S STUDIOS

5-50 51st Ave., Long Island City, NY 11101
(718) 937-5648 FAX (718) 937-2609

WRITE IN NO. 910

Superb grace of design.

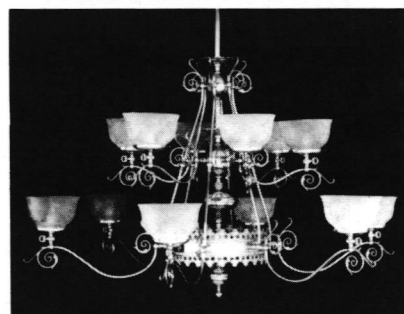

Send \$5 for our full color catalog.
(catalog fee refundable with order)

251 s. pennsylvania avenue
po box 469, centre hall, pa 16828
814-364-9577

Victorian Lighting Works



WRITE IN NO. 373

ANTHONY
WOOD PRODUCTS &
INCORPORATED
Box 1081TB Hillsboro, TX 76645
817/582-7225
Illustrated catalog available - \$2.00
Visa and Master Card Accepted

Victorian Gingerbread

Gable Trim	Porch Posts
Fretwork	Newel Posts
Brackets	Balusters
Corbels	Finials

And Much More

Custom Turnings, Custom Sized
Gingerbread & Reproduction
Services Available Upon Request.

1979 1993

WRITE IN NO. 602

Entrancing.

Furniture-quality doors and entryways in premium hardwoods; standard & custom sizes.

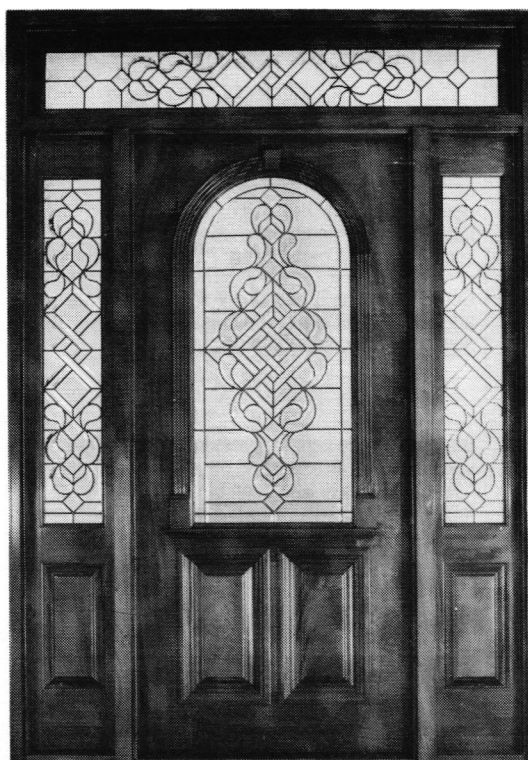

At Chautauqua Woods, every door and entryway is made to the highest construction standards from premium-grade hardwoods by master furniture builders.

Most Chautauqua Woods door styles have classic raised moldings on interior and exterior faces. Optional "Period Styled Packages" are available to match virtually any architectural style.

We can also supply rectangular transoms with rectangular or elliptical light openings, as well as a variety of sidelight styles. Call or write for more details. You'll discover that the finest quality is also affordable. All doors are handcrafted in the United States.

Chautauqua Woods

P.O. Box 3, Fredonia, NY 14063
(716) 679-7720 FAX: (716) 679-7780

WRITE IN NO. 965

WHEN ONLY A CRAFTSMAN WILL DO



Historically Accurate . . .

- Restoration of plain plaster
- Restoration of plaster ornament

Additionally, we offer:

- Scientific analysis & recreation of historic plaster
- Injected adhesives & reattachment of loose plaster

• TRADITION • AUTHENTICITY • QUALITY

Ewing Restoration Plaster Arts Studio

3068 E. Maple Ave., Burlington, NC 27215 Phone or Fax (919) 228-8022

WRITE IN NO. 238

VICTORIAN AND TURN-OF-THE-CENTURY Chandeliers, Sconces & Fixtures

• Design • Contract • Manufacturer • Restoration • Replacement Parts & Glass Shades

THE MOST COMPLETE SOURCE FOR ANTIQUE AND REPRODUCTION GAS, OIL AND ELECTRIC LIGHTING

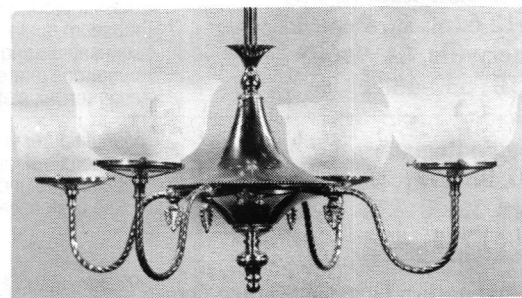

• THE FINEST LAMP & FIXTURE RESTORATION AVAILABLE •
Lighting Catalog \$5.00

ROY ELECTRIC CO., INC. (800) 366-3347
SHOWROOM: 1054 Coney Island Ave., Brooklyn, NY 11230
In N.Y. (718) 434-7002 Fax: (718) 421-4678

WRITE IN NO. 43

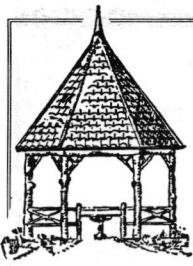

TRADITIONAL BUILDING's VICTORIAN REVIVAL *SourceList*

COMPILED BY SHARON GARBE

COMPANY	SPECIALTY	Literature	Metal Ornament	Gingerbread Fretwork Woodwork	Wood & Screen Doors	Hardware	Ceramic Tile	Molded Ornament	Wall Coverings	Art Glass	Plumbing Fixtures & Accessories	Lighting Fixtures	Other	New (N) or Antique (A)
Maguire Iron Corp. 215-22nd St., Dept. TB Richmond, CA 94801 (510) 234-7569	Antique reproduction builders' hardware in iron and other metals, locks, and accessories. Over 1,000 pieces for door, window, cabinet, and gate hardware; 150 matching locks and latches. Custom capabilities.	Free <i>Write in No. 760</i>				●								N
John L. Marti 3731 Walnut, Dept. TB Kansas City, MO 64111 (816) 931-8805	Company specializes in finely-detailed, abrasive-cut decoration on glass — new or old windows, lamp globes, etc.	Free								●				N, A
Milford Replacement Hardware 73 Ruth Ann Terrace, Dept. TB Milford, CT 06460 (203) 877-0606	Supplies a wide variety of restoration hardware with an emphasis on window hardware. Unique items can be reproduced using lost-wax casting.	Free <i>Write in No. 491</i>				●								N
Mother of Pearl & Sons 12328 Ventura Blvd., Dept. TB Studio City, CA 91604 (818) 505-8057	Makers of natural beeswax furniture polish and restoration hardware to the antique trade, restorers, and appropriate retailers. Importers of British Colonial antiques from India, such as hanging oil lanterns.	Free				●						●	Beeswax polish	
W.F. Norman Corp. P.O. Box 323, Dept. TB Nevada, MO 64772 (800) 641-4038	100-year-old company continues to offer a comprehensive collection of over 1,300 traditional architectural sheetmetal ornaments and sculpture, over 140 metal ceiling and wall panel patterns, and roofing products.	Free <i>Write in No. 52</i>	●					●					Metal roof shingles, cresting	N
North Fields Restorations P.O. Box 741, Dept. TB Rowley, MA 01969, Dept. TB (508) 948- 2722	Architectural salvage company carrying antique wide plank flooring in pine, oak, and chestnut.	Free <i>Write in No. 326</i>		●										A
Nowell's Inc. P.O. Box 295, Dept. TB Sausalito, CA 94966 (415) 332-4933	Stock and custom reproduction lighting fixtures of solid brass, copper, and bronze. Some styles in operating gas. Historically accurate styles from Victorian to Mid-20th Century. Also offers restored antique lighting and restoration services	Free brochure <i>Write in No. 618;</i> Catalog \$5										●		N, A
O'Connor's Cypress Woodworks P.O. Box 712, Dept. TB Washington, LA 70589 (318) 826-7749	Victorian gingerbread brackets, swings, benches, rockers, and tables, all made from durable cypress. All products are treated with a water sealant, and can be painted, stained, or left to weather.	Free <i>Write in No. 492</i>		●									Benches, swings, fern tables	N
The Old Wagon Factory P.O. Box 1427, Dept. TB Clarksville, VA 23927 (804) 374-5787	Victorian products such as porch furniture, gable decorations, gingerbread, and other woodwork, and storm/screen doors in all sizes, handcrafted of hardwood with mortise-&-tenon construction.	Free <i>Write in No. 780</i>		●	●			●	●			●	Victorian porch furniture	N
Thomas D. Osborn Mosaic Hardwood Floors 1421 Northampton St., Dept. TB Holyoke, MA 01040 (413) 532-9034	Specializes in custom design, fabrication, and installation of marquet and inlaid floors using native and exotic hardwoods. All work is done exclusively in 3/4 in. hardwood.	Free <i>Write in No. 479</i>		●										N
Peters & Son 1936 N. Front. St., Dept. TB Philadelphia, PA 19122 (215) 739-9500	Company carries period-styled hardware for shutters, doors, and gates.	Free <i>Write in No. 124</i>				●								N
Plaster Cast Designs P.O. Box 962, Dept. TB Shelbyville, TN 37160 (615) 685-0536	Hand-crafted architectural accents in reinforced plaster for restoration or new construction. Medallions, niches, moldings, mantels, and more.	Free <i>Write in No. 480</i>						●						N
Red Baron's Antiques 6450 Roswell Rd., Dept. TB Atlanta, GA 30328 (404) 252-3770	Company has a wide range of items from many periods, including Victorian; Interior and exterior architectural elements, furniture, garden furnishings, fine and decorative arts collectibles.	Free	●		●					●		●	Furniture, statuary	A
Reflection Studios, Inc. 1418 62nd St., Dept. TB Emeryville, CA 94608 (510) 652-4884	Studio produces exceptional stained glass reproductions, original work, and museum-quality restoration. It is a licensed glazing contractor with numerous references for large-scale commercial, state, and Federal projects.	Free <i>Write in No. 793</i>								●				NA
Reggio Registers P.O. Box 511, Dept. TB Ayer, MA 01432 (508) 772-3493	Manufactures a complete line of traditionally designed decorative cast-metal grilles and registers. Will also make custom castings.	Free <i>Write in No. 581</i>	●										Registers, grilles	N
Rejuvenation Lamp & Fixture Co. 1100 S.E. Grand Ave., Dept. TB Portland, OR 97214 (503) 231-1900	Manufacturer of Victorian and early 20th century solid brass lighting. Many gas-style fixtures and combination gas-electric styles. Also, custom capabilities.	Free										●		N

Handcrafted Wooden Furniture and Storm-Screen Doors

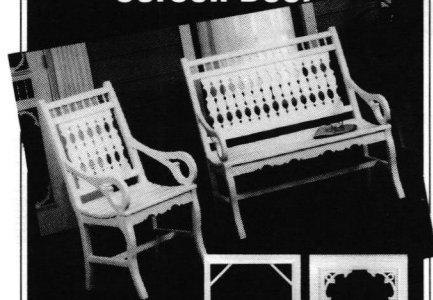

- Large selection of storm-screen doors in standard and custom sizes.
- Victorian porch furniture & trim.
- Planters and benches.
- Home and garden accessories.
- Custom orders welcome!

For color catalog, send \$2.00 to:
The Old Wagon Factory
P.O. Box 1427 Dept. TB73
Clarksville, VA 23927
(804) 374-5787

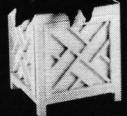

WRITE IN NO. 780

AFFORDABLE ELEGANCE



STARTING at \$262

BUY FACTORY DIRECT & SAVE!

Classic Lamp Posts manufactures the highest quality lighting posts and luminaires for residential and commercial installations. These unique lamp posts are molded of a steel-reinforced outdoor polymer and urethane laminate that we call "Polysteel".

Our polysteel posts offer:

- Lowest Cost
- Best Appearance
- Easiest Installation
- Lowest Maintenance

POLYSTEEL FROM 8' TO 15' TALL

Request your free color catalog today!

Classic Lamp Posts

3645 N.W. 67th Street • Miami, FL 33147
Toll Free 800-654-5852 In FL 305-696-1901

WRITE IN NO. 429

Largest Selection of Antique American Oak and Victorian Furniture in New England



Three Large Barns Full!

Constantly changing inventory!

Video tape (\$25) individually made for your specific needs



(413) 527-1022
Route 10
Southampton, MA 01073

Open: Thu., Fri., Sat. 10-5
Sun. 12-5—Closed August
Directions: Exit 3 off Mass. Pike (I-90), go 7 mi. north on Route 10.

WRITE IN NO. 463

gold leaf

Sepp Leaf is the leading supplier of gold leaf and gilding materials, offering the largest selection of genuine gold and metal leaves to the industry.

For further information, please call or write.



381 PARK AVE., SO., NEW YORK, NY 10016
Ph: 212-683-2840
Fax: 212-725-0308

WRITE IN NO. 288

SPIRAL STAIRCASES CUSTOM BUILT TO YOUR ORDER



Complete with beautiful wooden railing. The most attractive and priced far below the rest.

Both all wood and steel models available.

Prices start at \$385 for Steel, \$995 for All-wood.

Send for full color brochure or call 913-689-4341.

Goddard Manufacturing

Box 502, Dept. TB, Logan, KS 67646

WRITE IN NO. 478

H & R JOHNSON



MINTON HOLLINS,

The Victorian Collection

An Exclusive Collection of glazed ceramic tiles and profiled pieces.

150 years of manufacturing experience in "The Potteries", England's Bone-china capital.

Complementary geometric and encaustic floor tiles.

Coming soon: coordinating mirrors, trays and other home accessories.

North American Sales: Dept TB
190 Highway 18
East Brunswick, NJ 08816
Tel: 908-545-9161 Fax: 908-545-0869

WRITE IN NO. 568

BEAUTIFUL BRASS STAIR RODS

Finally, European Style Solid Brass Stair Rods and Finials at Good Old American Prices!

- The sleek lines of hand polished, rich Brass Stair Rods and beautiful End-Cap Finials will transform stair runners into total elegance.
- Each rod and finial is Hand Polished, and treated with High Gloss Enamel, thus eliminating the possibility of tarnishing.
- Easy to install: "patent pending" mounting brackets allow for simple installation for the do-it-yourselfer. Adjusts to any rug thickness. No shims or spacers required.
- Custom sizes: rods are available up to 12' in length.

FINIAL STYLES

UD-101 Medium Pyramid 1 1/8" long

UD-102 Large Pyramid 1 1/4" long

UD-103 Ball Finial 1 3/8" long

UD-104 Acorn Finial 1 1/2" long

UD-105 Teardrop Finial 1 1/2" long

UD-106 Pineapple Finial 1 1/2" long

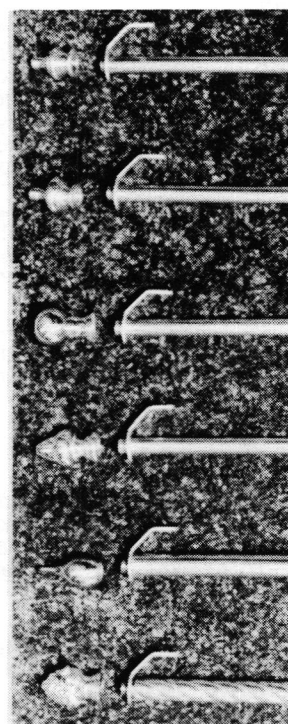

STAIR ROD STYLES

3/8" Solid Brass

1/2" Tubular Plain

1/2" Tubular Roped

MADE IN USA BY QUALITY CRAFTSMEN
SATISFACTION GUARANTEED

CALL OR WRITE FOR FREE BROCHURE

Unique Designs Mfg. Co.

308 E. Molloy Rd., Dept. TB, Syracuse, NY 13211 • (800) 468-8801

WRITE IN NO. 575

MAD RIVER WOODWORKS

- MOLDINGS
- PICKETS
- SCREEN DOORS
- PORCH PARTS

Catalog \$3.00
707-668-5671

P.O. Box 1067, Dept. TB3, Blue Lake, CA 95525

WRITE IN NO. 35

It's Really BIG!

RESTORATION '93 Exhibition & Conference
The largest preservation and restoration event in North America.
December 6-8, 1993 • Hynes Convention Center
Boston, Massachusetts • See page 71 for details

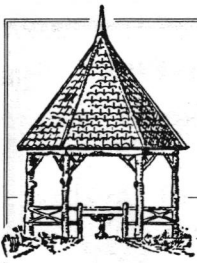

TRADITIONAL BUILDING's VICTORIAN REVIVAL *SourceList*

COMPILED BY SHARON GARBE

COMPANY	SPECIALTY	Literature	Metal Ornament	Gingerbread Fretwork Woodwork	Wood & Screen Doors	Hardware	Ceramic Tile	Molded Ornament	Wall Coverings	Art Glass	Plumbing Fixtures & Accessories	Lighting Fixtures	Other	New (N) or Antique (A)
Roy Electric Co. 1054 Coney Island Ave., Dept. TB Brooklyn, NY 11230 (718) 434-7002	New full product color catalog featuring 274 Victorian and Turn-Of-The-Century lighting fixtures — sconces, pendants, and flush fixtures — as well as 190 choices of glass shades. Also offers custom capabilities and restoration.	Free brochure <i>Write in No. 43;</i> catalog \$5										●		N
Wm. Bateman Ruffner & Co. 643 S. Peoria, Dept. TB Tulsa, OK 74120 (918) 584-0856	Company produces elegant metal birdcages in limited editions or custom designs.	Catalog \$10											Bird cages	N
Salt & Chestnut P.O. Box 41, Dept. TB W. Barnstable, MA 02668 (508) 362-6085	This company has hundreds of silhouette and swell-bodied weathervane designs to choose from. It also produces custom work and finials.	Free <i>Write in No. 659</i>	●										Weathervanes, finials	N/A
Sepp Leaf Products, Inc. 381 Park Ave. South, Dept. TB N York, NY 10016 (212) 683-2840	Suppliers of gilding products and tools: Gold leaf booklets and rolls, imitation gold and aluminum, sizes, burnishing clays, etc. Also associated with the Center for the Gilding Arts, which offers all levels of gilding courses and workshops.	Free <i>Write in No. 288</i>											Gilding supplies; gilding courses	
Shady Lady 418 E. 2nd St., Dept. TB Loveland, CO 80537 (303) 669-1080	Handmade fabric lampshades in Victorian, oriental, contemporary, and custom styles. Reproduction floor and table lamp bases. Will also convert art objects into lamps.	Folder \$4.50										●		N
Shuttercraft 282 Stepstone Hill Rd., Dept. TB Guilford, CT 06437 (203) 453-1973	Authentically-styled pine and cedar wood shutters for interior or exterior applications.	Free <i>Write in No. 44</i>											Shutters	N
Silver Creek Mill Rt. 4, Box 216B, Dept. TB Forsyth, MO 65653 (417) 546-4472	Victorian wood products. Specializes in sawn work: Brackets, running trim, and balusters. Also offers screen doors, furniture, and miniature houses.	Free <i>Write in No. 455</i>		●	●								Miniature houses, furniture, gates.	N
Silverton Victorian Millworks P.O. Box 2987, Dept. TB Durango, CO 81302 (800) 933-3930, (303) 259-5915	Manufactures a complete line of exterior and interior millwork, including Victorian, Country, and Southwest styles. Premium and standard-quality wood products available off-the-shelf from its large inventory.	Free		●	●								Casings, moldings, turnings	N
South Coast Shingle Co. 2220 E. South St., Dept. TB Long Beach, CA 90805 (310) 634-7100	Manufacturers of fancy-butt, hand-cut #1 cedar shingles, and distributors of all types of roofing materials and related items.	Free											Cedar shingles	N
Southampton Antiques 172 College Hwy., Rt. 10, Dept. TB Southampton, MA 01073 (413) 527-1022	Large selection of American Victorian furniture.	Free <i>Write in No. 463</i>											Furniture	A
Spoon River Millwork P.O. Box 363, Dept. TB London Mills, IL 61544 (309) 486-3745	Architectural millwork, including custom moldings, doors, windows, casework, stairs, and Victorian etched-glass panels.	Free <i>Write in No. 853</i>		●						●				N
Spring Lighting Co. 6164 S. Eastern Ave., Dept. TB Commerce, CA 90040 (213) 728-2391	Manufacturers of period lighting fixtures. Custom capabilities.	Free										●		N
Steptoe & Wife Antiques, Ltd. 322 Geary Ave., Dept. TB Toronto, Ont. Canada M6H 2C7 (800) 461-0060, (416) 530-4200	Stock products include cast-iron straight and spiral staircases and railings, shipped knocked down to jobsite. Also, decorative iron and steel curtain hardware, and custom fabrication.	Free <i>Write in No. 47</i>	●										Stairs, drapery hardware	N
Sunflower Showerhead Co. P.O. Box 4218, Dept. TB Seattle, WA 98104 (206) 722-1232	Victorian-styled reproduction of an 8 in. diameter showerhead. The product is chrome-plated copper, and has a five-year warranty. Shower-arm bracket available, or installs with 1/2 in. standard fittings.	Free <i>Write in No. 294</i>									●			N
Sunrise Specialty Co. 5540 Doyle St., Dept. TB Emeryville, CA 94608 (415) 654-1794	Period bathroom fixtures such as slipper tubs, oak tank toilets, and water closets, as well as accompanying fittings, and 3- and 5-arm chandeliers.	Free <i>Write in No. 464</i>									●	●		N
Thermo-Rite P.O. Box 1108, Dept. TB Akron, OH 44309 (800) 321-0313	Company originated the use of tempered glass fireplace doors 45 years ago. It offers a broad line of traditionally-styled, solid brass enclosures, gas logs, grates, and tool sets.	Free <i>Write in No. 523</i>											Fireplace enclosures and accessories	N
Richard E. Thibaut, Inc. 706 South 21st St., Dept. TB Irvington, NJ 07111 (201) 399-7888	Historic reproductions of wallpapers, borders, and fabrics. Designs range from rich florals to Patrician stripes. Papers are pre-pasted, strippable, and scrubbable; fabrics are screen-printed on stain resistant 100% cotton.	Free <i>Write in No. 42</i>							●				Screen-printed fabrics	N

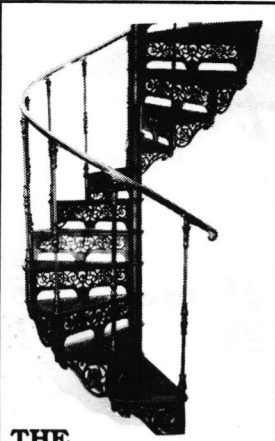

THE BARCLAY

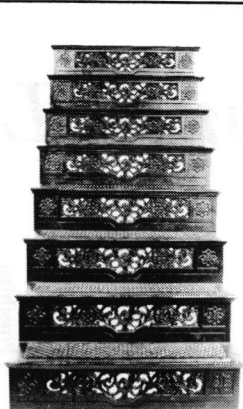

THE KENSINGTON

Steptoe Manufactures & Distributes Quality Restoration Products:

- Cast iron spiral staircases
- Cast iron straight staircases
- W.F. Norman steel ceilings (Canada only)
- Anaglypta & Lincrusta embossed wallcoverings (Canada only)
- Shower convertos for old tubs (Canada only)
- Brass & steel railing systems
- Lawler cast iron railing & architectural detail (Canada only)
- Custom casting
- Solid teak garden furniture
- Plaster cornice & medallions
- Wood cornice moulding
- Exterior lighting



322 Geary Avenue
TORONTO, ONTARIO M6H 2C7
(416) 530-4200 FAX (416) 530-4666

100 Years Behind the Times.™

WRITE IN NO. 47

J.R. BURROWS & COMPANY

HISTORICAL - DESIGN MERCHANTS

Specialists in Victorian Pattern Design Since 1985



● 1880's Arts & Crafts Movement Wallpaper and Fabric

● William Morris Carpet

● Wilton & Brussels Carpet

● Nottingham Lace Curtains

● Catalog & Samples \$5⁰⁰
617/982-1812

P.O. Box 522, 393 Union St., Rockland, Mass. 02370

WRITE IN NO. 693

WOOD SCREEN DOORS

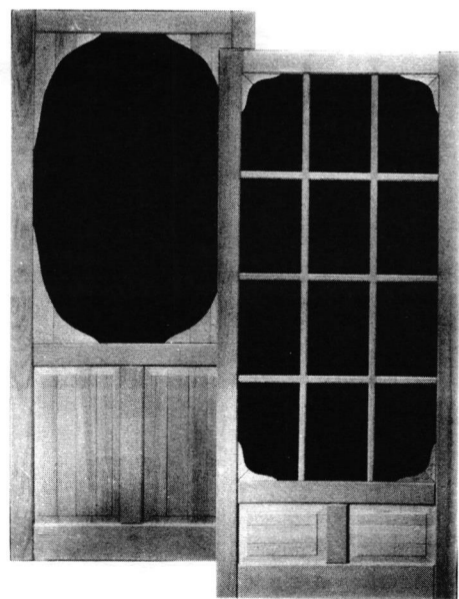

90 STYLES
ANY WOOD
ANY SIZE
ANY COLOR

FREE CATALOG

CIRO C. COPPA

1231 Paraiso Ave.
San Pedro, CA 90731
310/548-4142

WRITE IN NO. 960

Learning The Secrets Of The Gilding Guild

Of all the traditional crafts, the one that still retains its mystery is gilding and gold leafing. All that is changing with the opening of the *Center For The Gilding Arts*.

This new teaching facility is holding continual classes and hands-on workshops on: Architectural Gilding, Traditional Water Gilding, The Kolner Water Gilding System, Oil Gilding, Glass Gilding, Antiquing, Toning, and Illumination, Compo Casting — and much more. Weekly classes are offered for both novices and professionals. Weekend and "crash" courses are available to meet the needs of active professionals. Special seminars feature important developments in the craft and artistry of gilding.

The Center For The Gilding Arts is located at 381 Park Avenue South (at 27th St.), New York, NY 10016. For more information and class schedules write or call Bill Gauthier at (212) 683-4822 FAX (212) 725-0308. Or Write in No. 514

★ PRESERVING THE INTEGRITY OF A NATIONAL MONUMENT ★

New Windows for the Smithsonian Castle

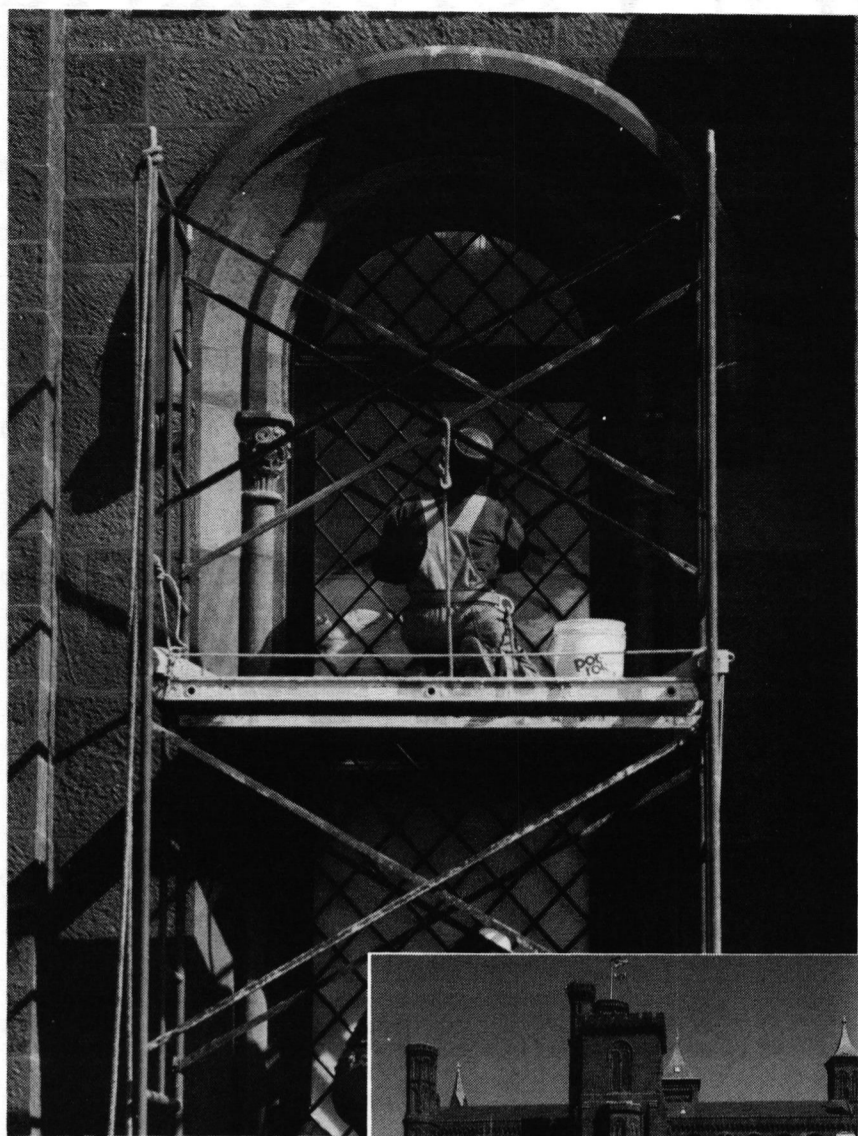

When the keepers of the nation's attic were faced with the daunting task of replacing over four hundred very historic windows, they came to us.

We showed them they could increase energy efficiency, reduce ultraviolet light and sound transmission, while maintaining absolute faithfulness to precise historic detail.

James A. Cassidy Co., Inc. was awarded the prestigious Architectural Wood working Institute's Award of Excellence for "Design and Quality."

Please contact us for more information of this and other historic window projects we have successfully completed.

JAMES A. CASSIDY CO., INC.

P.O. Box 749 Seaford, Delaware 19973
PHONE (302) 629-7600 FAX (302) 629-7649

ENGINEERING ★ DESIGN ★ TESTING ★ INSTALLATION ★ PROJECT MANAGEMENT

WRITE IN NO. 126

*Cartouches
Friezes
Centerpieces
Brackets*

*Niches
Cornice
Grilles
Mouldings*

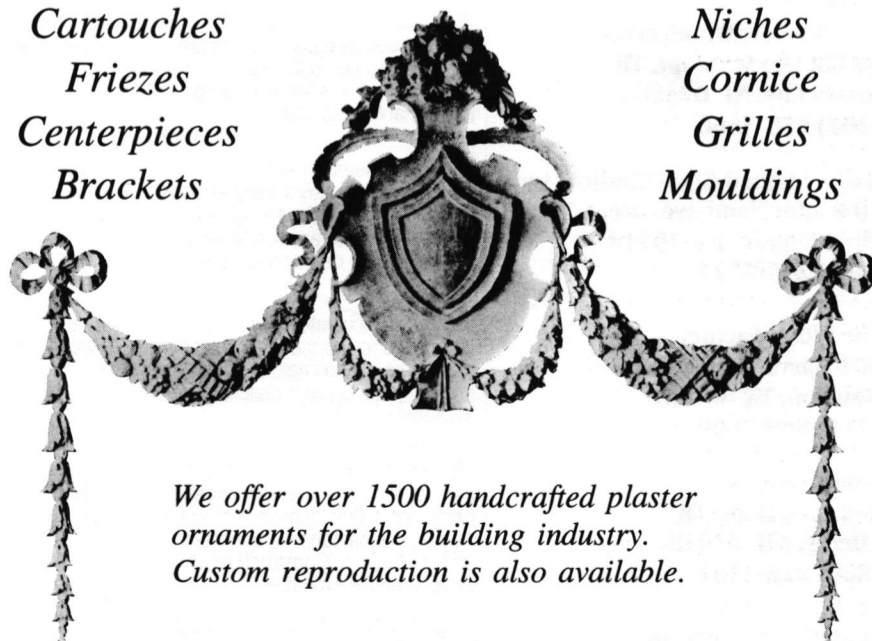

We offer over 1500 handcrafted plaster ornaments for the building industry. Custom reproduction is also available.

The Fischer & Jirouch Co.
4821 Superior Ave., Dept. TB
Cleveland, OH 44103



Bus. Tel. (216) 361-3840
FAX Tel. (216) 361-0650

WRITE IN NO. 196

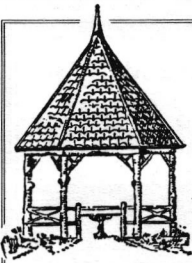

TRADITIONAL BUILDING's VICTORIAN REVIVAL *SourceList*

COMPILED BY SHARON GARBE

COMPANY	SPECIALTY	Literature	Metal Ornament	Gingerbread Fretwork Woodwork	Wood & Screen Doors	Hardware	Ceramic Tile	Molded Ornament	Wall Coverings	Art Glass	Plumbing Fixtures & Accessories	Lighting Fixtures	Other	New (N) or Antique (A)
Tile Restoration Center 3511 Interlake N., Dept. TB Seattle, WA 98103 (206) 633-4866	Experienced with custom glaze matching for Trent, Hamilton, AETCO & others of Victorian era. High-relief porcelain tile, borders, and accent pieces. Celadon, rust, and other specialty glazes available.	Free					●							N
Timeless Garden P.O. Box 5406, Dept. TB Arlington, VA 22205 (703) 536-8958	This small company researches and reproduces historic garden gates. The gates are handcrafted, one at a time, from clear, all-heart redwood.	Free <i>Write in No. 990</i>											Garden gates	N
Touchstone Woodworks P.O. Box 112, Dept. TB Ravenna, OH 44266 (216) 297-1313	Custom specialists in Victorian and traditional screen/storm doors. Doors are made-to-order from Honduras mahogany with interchangeable screen and tempered glass storm panels. Many styles to choose from or will custom design.	Free <i>Write in No. 784</i>			●									N
Turn of the Century Lampshades P.O. Box 6599, Dept. TB Bend, OR 97708 (503) 382-1802	Reproduction Victorian fabric lampshades and bases. 50 styles and 40 color combinations available with either fabric or beaded fringe.	Free										●		N
Unique Designs Mfg. Co. 308 E. Molloy Rd., Dept. TB Syracuse, NY 13211 (315) 455-8801	Brass stair rods with decorative end-cap finials. Standard and custom sizes up to 12 ft. in length. Mounting brackets adjust to any rug thickness.	Free <i>Write in No. 575</i>											Stair rods	N
Victorian Collectibles 845 E. Glenbrook Rd., Dept. TB Milwaukee, WI 53217 (414) 352-6971	Specializes in Victorian wallpapers, area rugs, and fabrics. Has extensive collection of authentic reproductions of American Victorian patterns. Design service available.	Free <i>Write in No. 525</i>							●				Rugs, fabrics	N/A
Victorian Lightcrafters, Ltd. P.O. Box 350, Dept. TB Slate Hill, NY 10973 (914) 355-1300	Hand-crafted lighting fixtures in solid brass. Over 50 Victorian designs.	Free <i>Write in No. 465</i>										●		N
Vixen Hill Mfg. Main St., Dept. TB Elverson, PA 19520 (215) 286-0909	Top-of-the-line gazebos in many designs — including adaptations for each season — manufactured from select-grade western red cedar; engineered for both strength and ease of assembly. Also cedar shutters.	Free <i>Write in No. 123 for shutters; Write in No. 710 for gazebos</i>											Gazebos, shutters	N
Washington House Reproductions P.O. Box 246, Dept. TB Washington, VA 22747 (703) 675-3385	Restoration of antique lighting devices and custom reproduction lamps and lighting fixtures in solid brass. Also, electric Dietz Pioneer "kerosene" street lights.	Free <i>Write in No. 466</i>										●		N, A
Watercolors, Inc. Garrison, NY 10524 (914) 424-3327	Exclusive importers and distributors of authentic English Victorian bathroom and kitchen faucets and accessories. Fittings for U.S. specs. Chrome, brass, gold, nickel, and enamel finishes.	Free									●			N
J.P. Weaver Co. 2301 W. Victory Blvd., Dept. TB Burbank, CA 91506 (818) 841-5700	Over 8,000 molded carving selections available. Products are pliable and will contour and self-bond to any sealed surface such as mirror, plaster, drywall, wood, metal, ceramic. Scaled-design books (1/4 in. = 1 in. scale).	Brochure \$5						●						N
Ron Wiener, Woodcarver 54 Cottage St., Dept. TB Jersey City, NJ 07306 (201) 659-5666	Woodcarvings of original and reproduction designs. Designs are digitized in order to achieve accuracy in copies. All work is finished using traditional carving tools.	Free <i>Write in No. 509</i>		●										
Willet Stained Glass Studios, Inc. 10 E. Moreland Ave., Dept. TB Philadelphia, PA 19118 (215) 247-5721	Studio has been in existence since 1898, creating leaded, stained glass, and sand-carved glass windows for residential, commercial, and religious buildings. Also offers restoration services.	Free								●				N
The Wood Factory 901 Harvard, Dept. TB Houston, TX 77008 (713) 863-7600	Historically accurate millwork: Designs have been researched and copied from turn-of-the-century catalogs and photographs. Custom matching available.	Free <i>Write in No. 712</i>		●	●	●							Weather vanes, mailboxes, doorbells	N
Wood Visions Box 815, Dept. TB Derry, NH 03038 (800) 628-1101	Modular "furniture quality" gazebos in three styles and sizes with screening packages. Other landscape products: Arbors, custom fencing, bandstands, and footbridges. Construction and design service available.	Free <i>Write in No. 987</i>											Gazebos, arbors, fencing, footbridges, bandstands	N
Yankee Barn Lighting P.O. Box 95, Dept. TB Forestburgh, NY 12777 (914) 794-7299	Large selection of Victorian-style glass shades, brass bases, and replacement components for Victorian fixtures.	Free								●		●		N
Zina Studios, Inc. 45 S. 3rd Ave., Dept. TB Mt. Vernon, NY 10550 (914) 667-6004	Specializes in line-for-line reproductions of documentary printed fabrics and wallcoverings for historic houses, preservation societies, and museums. Company also supplies reproductions of antique swiss bobbinet embroidered cotton curtains.	Free <i>Write in No. 467</i>							●				Fabrics	N

**Affordable
Elegance
...in solid brass**

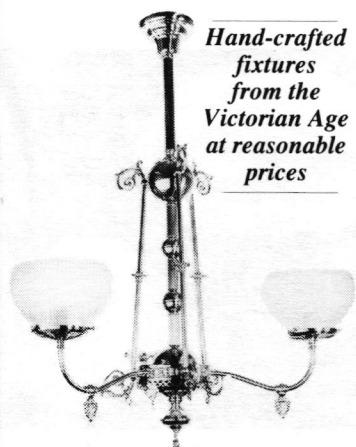

*Hand-crafted
fixtures
from the
Victorian Age
at reasonable
prices*

Send \$3.00 for our catalog with
over 50 authentic designs.

Victorian Lightcrafters, Ltd.

P.O. Box 350R
Slate Hill, NY 10973

Our fixtures are made with pride in the USA

WRITE IN NO. 465

**BROWN
STAINED GLASS STUDIO**

◆ CHURCHES • COMMERCIAL • RESIDENTIAL ◆

Our capabilities include:
Designing • Restoring • Beveling
Construction • Custom Etching
100% Custom

(210) 734-2653
910 San Francisco Street
San Antonio, TX 78201

WRITE IN NO. 605

**2 RESOURCES -for-
CLASSIC HOMES**

**BATHROOM
Machineries
CATALOGUE**



Victorian & Early American
Bathroom Fixtures & Accessories
Antiques & Replicas
Hard-To-Find Parts

**VICTORIAN
DOOR
& CABINET
HARDWARE**

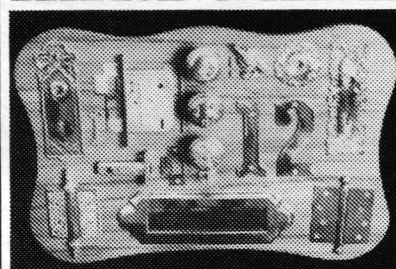

Our Victorian Door and Cabinet
Hardware Catalogue has what we
have found to be the most asked for
hardware plus many hard-to-find items
such as floor registers, bar rails, towel
bars, stair rods and ice box hardware.

*These catalogues have complete ordering and
reference information. Send \$3 for each
Catalogue- indicate Victorian Hardware or
Bathroom Machineries.*

DEA Bathroom Machineries
Box 1020TB • Murphys, CA 95247
(209) 728-2031

WRITE IN NO. 586

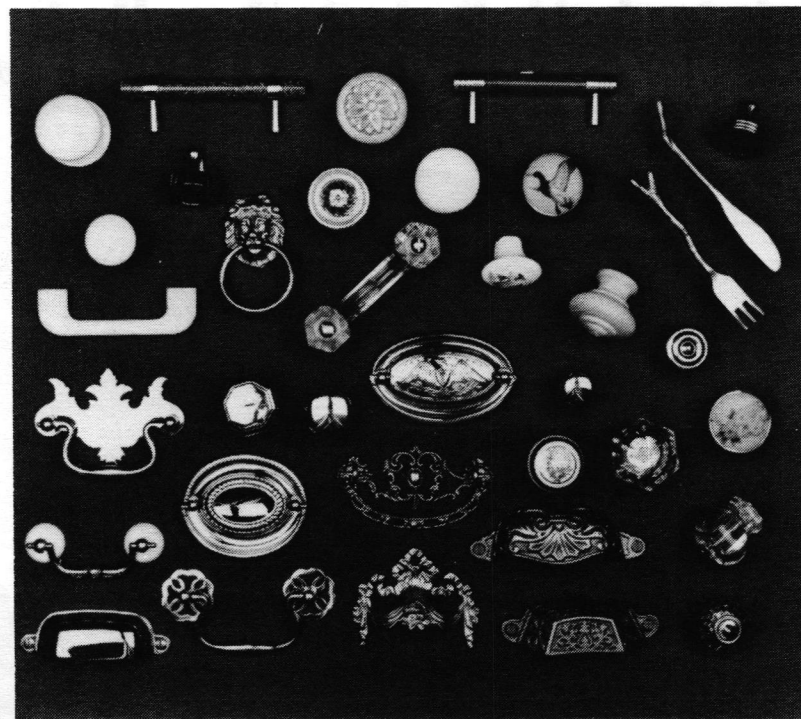

**Victorian, Traditional,
Classic and Contemporary**

Discover our extensive Collection of
Hardware – perfect for renovations
or new construction.

Retail and to the Trade

KNOB'S 'N' KNOCKERS®

The Ultimate Source for Decorative Hardware
Peddler's Village • Lahaska, PA • 215-794-8045

WRITE IN NO. 775

CONSERVATION SERVICES

- ◆ Stained and Decorative Glass
- ◆ Historic Wood Windows
- ◆ Masonry



OUR SERVICES INCLUDE: Existing Condition Surveys; Materials
Specifications; Restoration Program Development; Project
Management; Quality Assurance; Execution of the Work.

WE ARE PLEASED TO COUNT THE FOLLOWING FINE ORGANIZATIONS AND INSTITUTIONS AMONG OUR CLIENTS:
Smithsonian Institution and Metropolitan Museum of Art, NY;
U.S.M.A. Cadet Chapel, West Point, NY; Tulane University, New
Orleans, LA; Biltmore Estate, Asheville, NC; St. Paul's Episcopal
Church, St. Croix, U.S.V.I.; Teien Museum, Tokyo, Japan

ARS

**Association of
Restoration
Specialists, Inc.**

122 Clinton St., Hoboken, New Jersey 07030
(201) 795-1103 Fax (201) 420-8968

WRITE IN NO. 402

**GRILLES
DOORS**

BRIAN F. LEO

612-861-1473

7532 Columbus Avenue South
Richfield, Minn. 55423

**REGISTERS
FOUNTAINS**

**CUSTOM
HARDWARE**

Many styles &
designs...

**HINGES • KNOBS
PLATES • PULLS
ACCESSORIES**

Replicating of your
originals a
specialty.

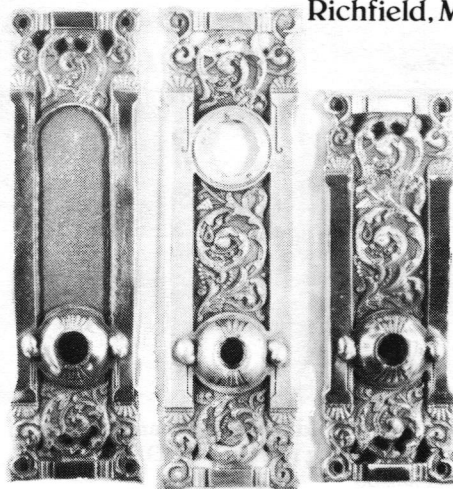
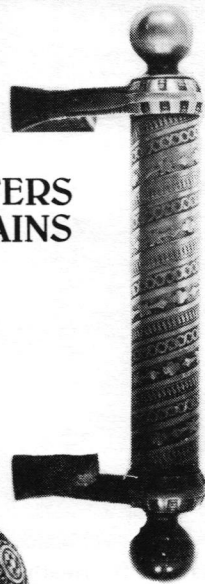

WRITE IN NO. 584

BRILLIANT CUT GLASS



**A·N·T
ART**

P.O. BOX 753 TRUMANSBURG, NY 14886 607-387-5473

European Craftsmen

Victorian restoration & recreation of art glass
Consulting • Design • Installation

WRITE IN NO. 860

VICTORIAN REVIVAL PRODUCTS

For more information on these companies, consult the Sourcelist on pp. 42-56.



Anglo-Japanese style credenza with inlaid foliage, dragons, and geometric patterns. RED BARON'S ANTIQUES. Write in No. 989

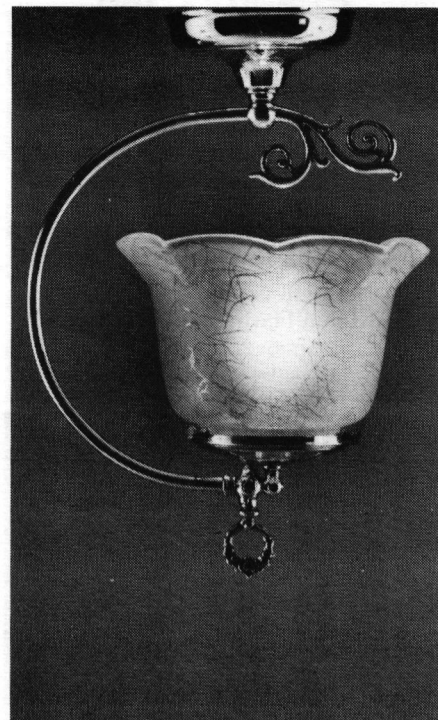

The "Polk Gulch" by NOWELL'S INC., is a gas-style ceiling fixture shown here with a 4 in. Snowflake shade. The total length is 16 in. Write in No. 618

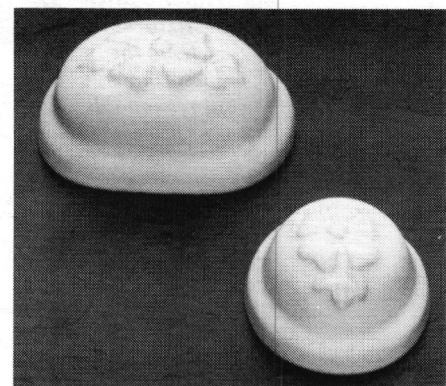

Wildflower oval and round white china toilet bolt cover from A-BALL PLUMBING SUPPLY. Write in No. 242



CLASSIC ILLUMINATION's Griffin table lamp, Model# 14. Write in No. 597

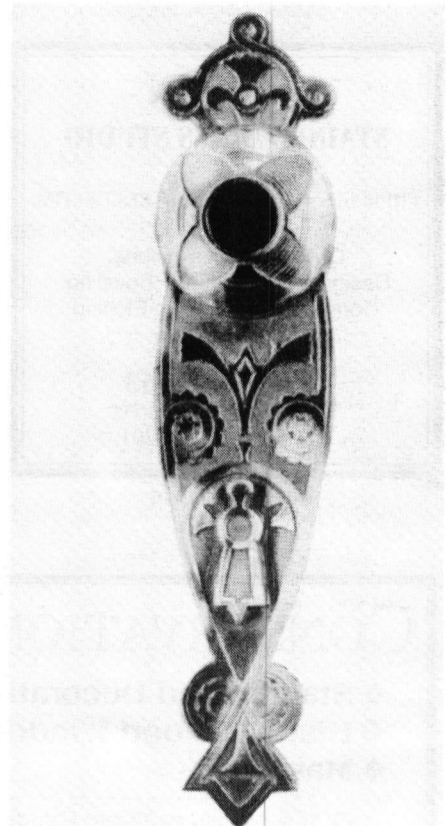

Solid cast bronze escutcheon plate (No. 139) is 9 in. H. and features a swivel key cover. From BRIAN LEO HARDWARE. Write in No. 584

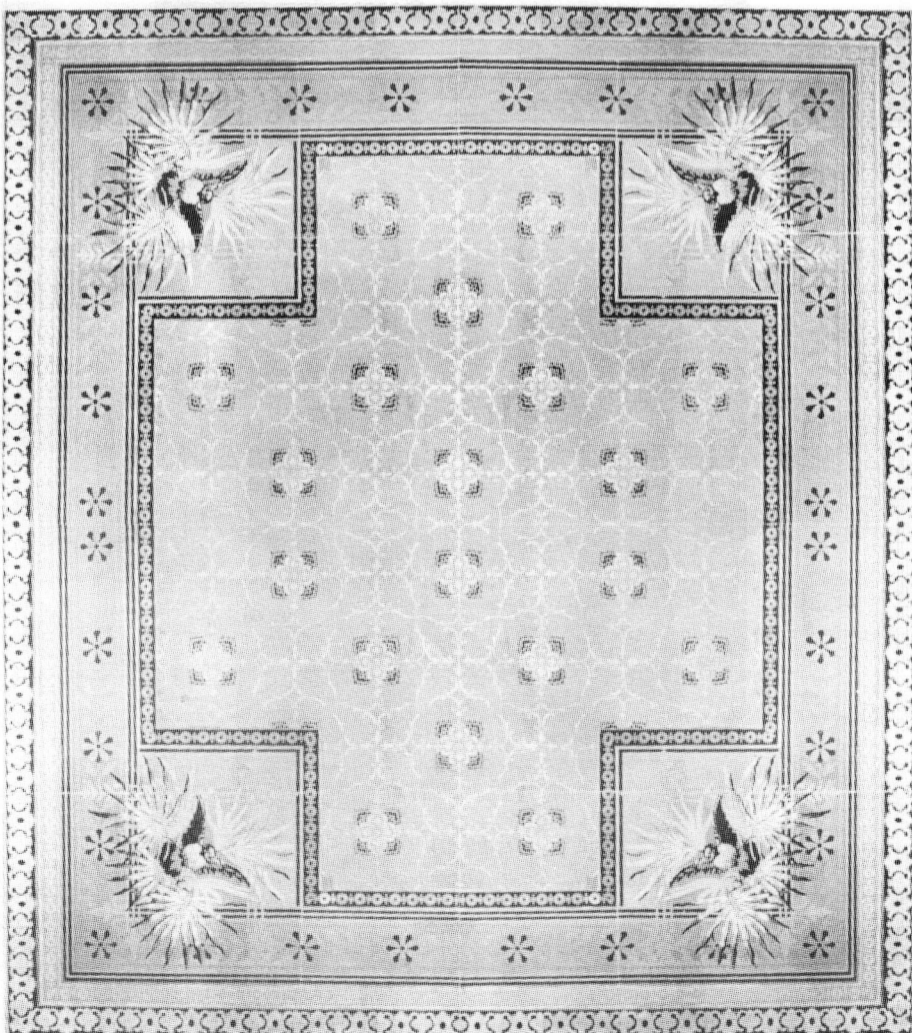

"Liberty Bird" ceiling paper from the Brillion Collection, available from VICTORIAN COLLECTIBLES. Write in No. 525

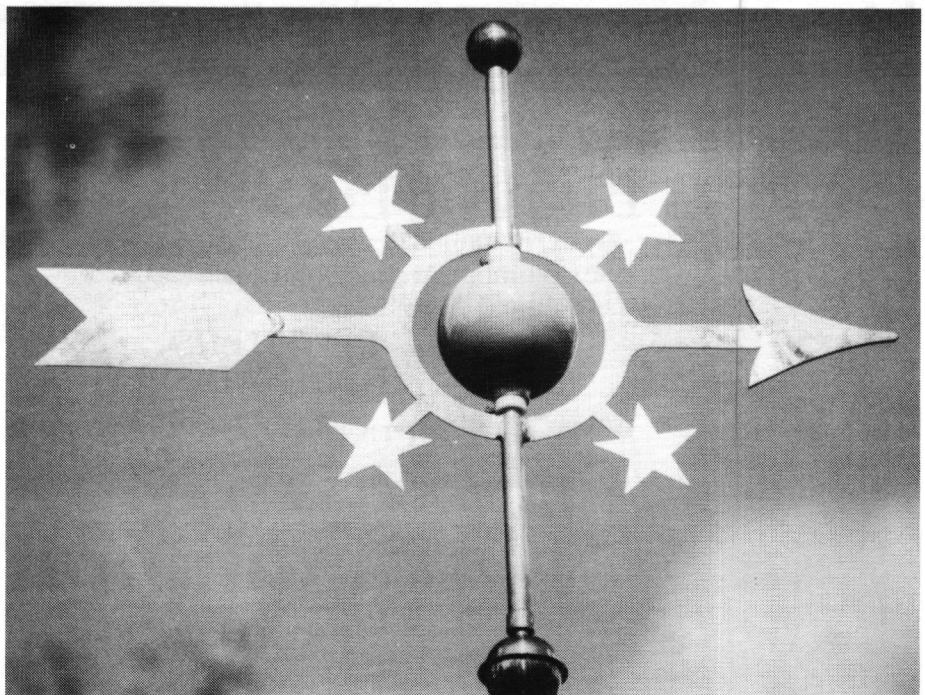

This fanciful weathervane called "Stargazer", with gold leafed stars and sky blue ceramic globe, was modeled after an antique lightning rod vane by DENNINGER CUPOLAS & WEATHERVANES. Write in No. 730

The Glory Of Glass

- Commercial Projects:
- Offices
- Banks
- Clubs
- Restaurants
- Custom Designs and Patterns

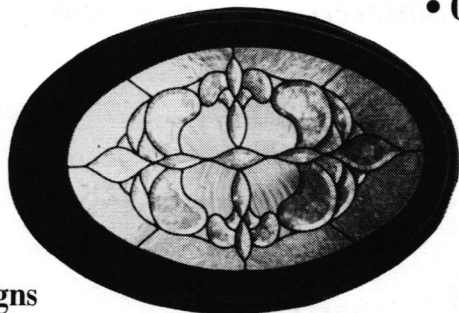

- Glass Creations for
- Doors
- Windows
- Room Dividers
- Tables
- Nationwide Service

2401 Government Street, Mobile, AL 36606
(205) 479-3392

Art Glass of the South

WRITE IN NO. 251

CUSTOM LIGHTING

BUILT TO YOUR SPECIFICATIONS

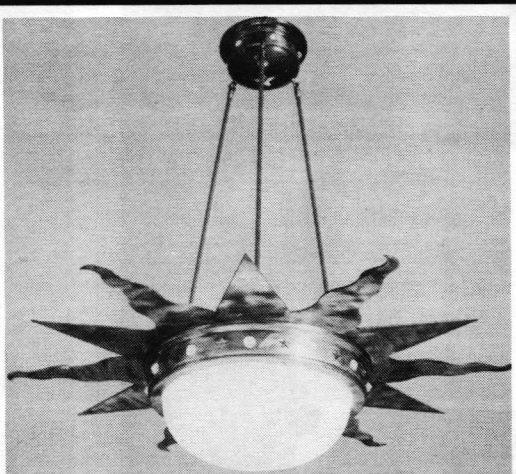

DESIGN BY: GORALNICK • BUCHANAN A + D

CONANT CUSTOM BRASS, INC.
270 PINE STREET BURLINGTON, VT 05401
TEL: 802-658-4482 FAX: 802-864-5914

WRITE IN NO. 62

Zina Studios, Inc.



45 SOUTH THIRD AVENUE
MT. VERNON, NY 10550
(914) 667-6004

*Designers and Manufacturers
of Museum quality
Fabrics and Wallcoverings
for Historic Buildings*

WRITE IN NO. 467

Arts & Crafts Tiles ■ Gothic Revival Tiles

Persian Revival Tiles ■ De Morgan Tiles ■ Foliate Tiles ■ Folk Tiles

Art Nouveau Tiles ■ Neo-Grec Tiles ■ Murals ■ Art Deco Tiles

California Arts & Crafts Tile
Hispano-Moresque Style

Designs In Tile

Box 358 ♦ Dept T ♦ Mt Shasta ♦ CA ♦ 96067
916/926-2629 Color Brochure \$3.

WRITE IN NO. 25

Kevin Rutan's FE FI FAUX, INC.

WORKSHOPS in faux finishes

3-day instruction in marblizing • wood graining • wall glazing • fantasy finishes offering complete instruction in all aspects of faux finishes for both the novice and professional

For information
(919) 272-3289
8:30-2:30 EST

337 S. Davie Street • Greensboro NC 27401

WRITE IN NO. 449

Shutters & Hardware

that are history...

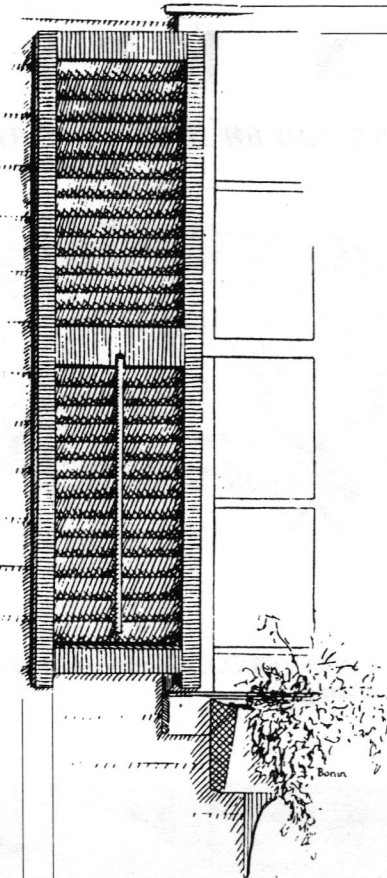

Complete Service Provided

- replicate any shutter or hardware
- technical drawings for Historical Commissions
- consultation and site visits
- installation

TRADITION & QUALITY

since 1856

Beech River Mill Corp.
Old Rte. 16, Dept. TB, Ctr. Ossipee, NH 03814
Phone & Fax (603) 539-2636
1-800-621-2636
Send \$3.00 for Catalog

WRITE IN NO. 411

ANTIQUE FLOORING

North Fields Restorations is the largest supplier of antique flooring in the Northeast. We specialize in authentic old flooring taken from buildings we have dismantled. Our antique pine and southern yellow pine come in widths up to 24" wide. We also stock oak and chestnut flooring up to 20" wide.

Many other restoration materials are in stock, such as hand-hewn beams, barn siding, mantels, doors, brick, and granite. We also have complete dismantled houses from \$25,000 to \$60,000. Videos of the houses are available for \$10.

Please direct inquiries to Mark Phillips at (508) 948-2722.
North Fields Restorations, Box 741, Rowley, MA 01969



WRITE IN NO. 326

VICTORIAN REVIVAL PRODUCTS

For more information on these companies, consult the Sourcelist on pp. 42-56.

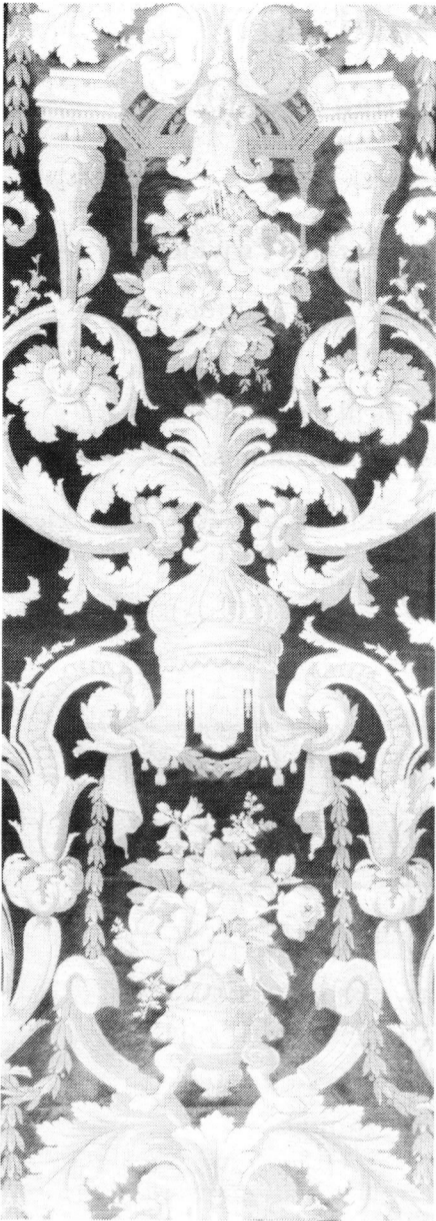

CLASSIC REVIVALS had this fabric re-woven for Newport's Vanderbilt mansion, Marble House, by the company who had originally woven it in 1892. A copy of the original order and a small cutting were found in the archival ledger books of Prella & Cie of Lyons, France. *Write in No. 610*

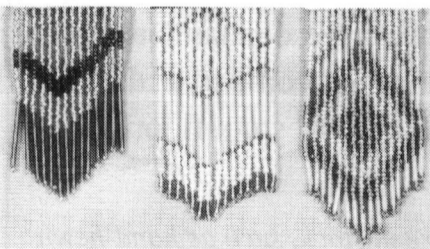

A sampling of beaded fringe available from TURN OF THE CENTURY LAMPSHADES, INC.

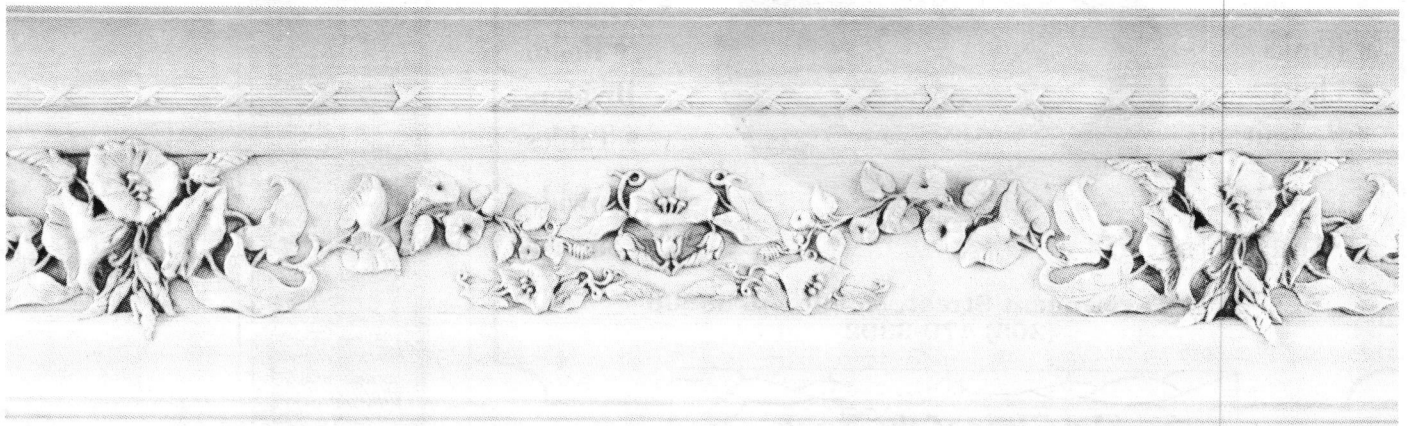

The J.P. WEAVER CO. has close to 8,000 different composition ornaments, including this morning-glory vine and bundled-reed molding.

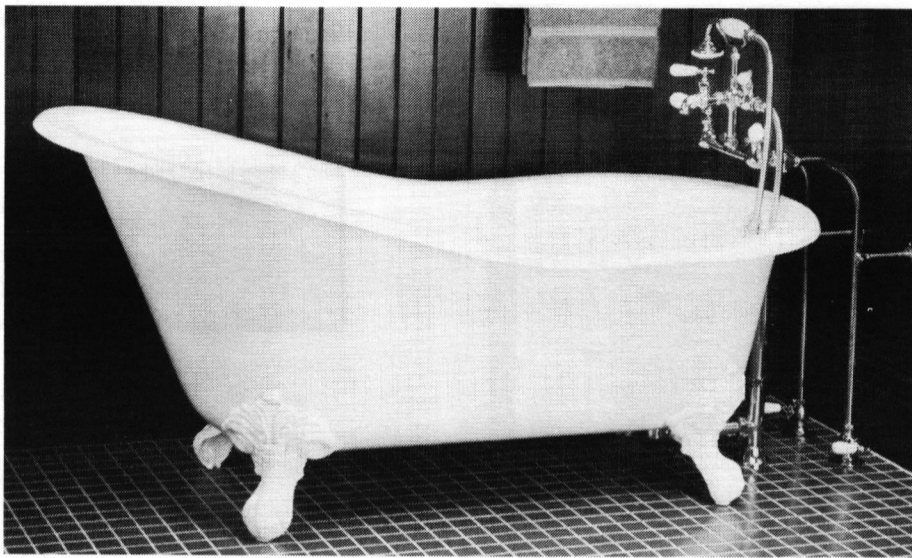

Imperial feet support this period slipper tub from SUNRISE SPECIALTY CO. *Write in No. 464*



In this photo, Brian Ewing, of EWING RESTORATION, installs a ceiling center-piece coated with polyvinyl acetate and adhered with wallpaper hanger's glue mixed with casting plaster. Plaster washers and drywall screws were affixed to joists were and pointed. *Write in No. 238*

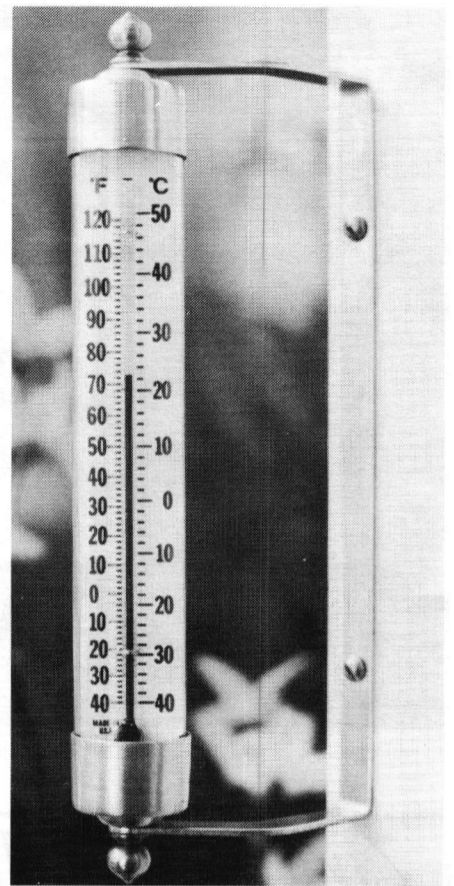

"The Vermont Thermometer" by CONANT CUSTOM BRASS was inspired by one found in an antique shop in rural Vermont. It also comes in a tabletop model. *Write in No. 62*



Basin with "Ornamental Band" available from CHRISTINE BELFOR DESIGNS, LTD. *Write in No. 351*



Typical spandrel and grillework, offered by CUMBERLAND WOODCRAFT CO., used in a Victorian restoration. *Write in No. 131*

SHUTTERS

HISTORIC SHUTTER & RESTORATION, INC.

Specializing in Handcrafted Interior & Exterior Shutters

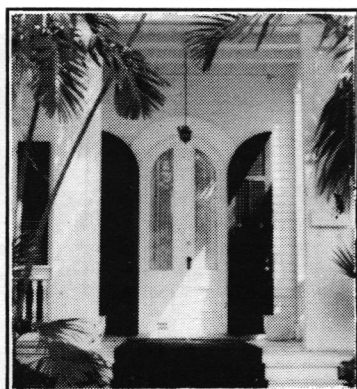

RESTORED 1980

Historic Shutter & Restoration is renowned for its high quality manufacturing & restoration. They were chosen to participate in two of Key West's finest landmarks - the Old City Hall, featuring their solid arched top, raised panel design & also the Lighthouse keeper's quarters, featuring recycled antique cypress with adjustable louvers. Historic Shutter can completely restore any wooden shutter, one window or your entire house. "So recycle, save money and a tree."

Guaranteed Quality, Craftsmanship & Service
5700 4th Avenue, Key West, Florida 33040
305-296-6332

WRITE IN NO. 85



THE LEADER IN CUSTOM ARCHITECTURAL ORNAMENTATION

Cornices • Ceiling Medallions • Niche Caps
Capitals • Brackets • Sculpture • Plaques
Domes • Cartouches • Tudor Ceilings
Adam Ceilings • Coffers
Plus custom design, consultation and fabrication.



FELBER
ORNAMENTAL
PLASTERING CORP.

P.O. Box 509, 110 Ardmore Avenue, Ardmore, PA 19003-0509,
215-642-4710, 1-800-392-6896, FAX: 215-642-4863

WRITE IN NO. 289

Victorian Furniture



Victorian Screens Ready for your Material

74" Screen \$224.00
50" Screen \$134.00

Screens, Swings, Gliders,
Tables and Benches
Natural Oak or Painted White

Color Brochure \$1.00
Satisfaction Guaranteed

GREEN ENTERPRISES

43 South Rogers Street, Hamilton, VA 22068
(703) 338-3606

WRITE IN NO. 966

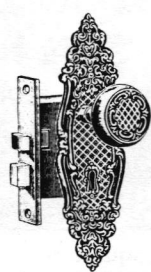

Authentic Antique Hardware

- One of a Kind
- No Reproduction
- Door Hardware
- Furniture Hardware
- Door Knockers
- Curtain Tie-backs
- Twist Bells

Eugenia's Place

Authentic Antique Hardware
3522 Broad St. • Chamblee, GA 30341 (404) 458-1677

WRITE IN NO. 431



SOLID BRASS HARDWARE

Furniture & House
2,000 Items in stock
Same day UPS shipping
Retail / Wholesale
Quantity discounts

Send \$5.00 for catalog set, refundable on 1st. order to:

A CAROLINA CRAFTSMAN
975 S. AVOCADO STREET
ANAHEIM, CA. 92805
(714) 776-7877 FAX: (714) 533-0894

WRITE IN NO. 424

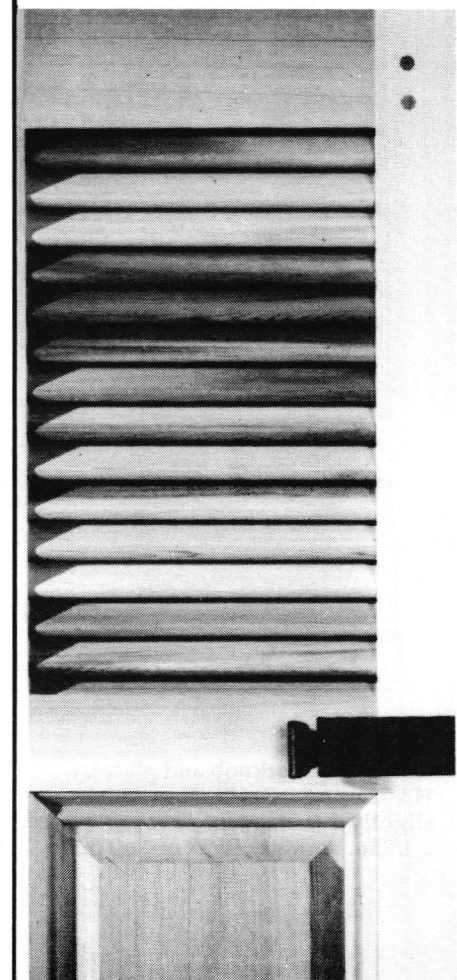

Our all-cedar shutters endure for generations.

Cheap pine shutters with steel staples can fail in as few as five years. And plastic is . . . well, plastic. So to build the Vixen Hill shutter, we use only clear, Canadian red cedar. Joints are mortise-and-tenon, with teak locking pins. Both panels and louvers are of generous dimensions, ensuring lasting beauty for generations.

For a detailed brochure, contact:

**Vixen Hill
Cedar Shutters**
Elverson, PA 19520
1-800-423-2766

WRITE IN NO. 123

"THE POLYGEL[®] MOLD

IS THE BEST MOLD WE EVER MADE."

...Russ Vieder, principal
American Architectural Art Co.,
Adamstown, PA

Recently, Matt Axel and Bob Matthias of Edon Corp. in Horsham, Pa. restored the facade of Philadelphia's renown Widener Building with Russ Vieder. They used fiberglass parts made in Polytek Rubber molds from Polytek's liquid rubbers. These nationally recognized Master Moldmakers say the Polytek materials produced the best mold they ever made. That says it all.



Restored facade of Widener Building. Capitals and horizontal ornamentation were made of fiberglass reinforced polyester resin in Polytek Rubber Molds.

Polytek's Patented Polygel self-thickening liquid rubbers for brush-on molds feature:

- Exceptional detail reproduction.
- Ease of use. 1:1 two-part mix.
- High tear resistance; Can be fabric reinforced.
- Cost efficiency. Brush-on molds use less rubber.
- Expert technical support from Polytek.



"After casting 10 large fiber-glass parts, the mold was in such good condition we could have made 50 more." The 8 ft. by 7 ft. corinthian column capitals have 24 inch undercuts.

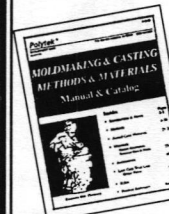

Polytek has a complete line of moldmaking materials. For our Moldmaking & Casting Methods & Materials Manual and Catalog that can answer all your moldmaking needs and a case history of the Widener Building restoration call (908) 534-5990, or write today.

Polytek[®]

P.O. Box T384, Lebanon, NJ 08833
(908) 534-5990 FAX (908) 534-5190

**The One Source for
Moldmaking Materials**

WRITE IN NO. 636

VICTORIAN REVIVAL PRODUCTS

For more information on these companies, consult the Sourcelist on pp. 42-56.

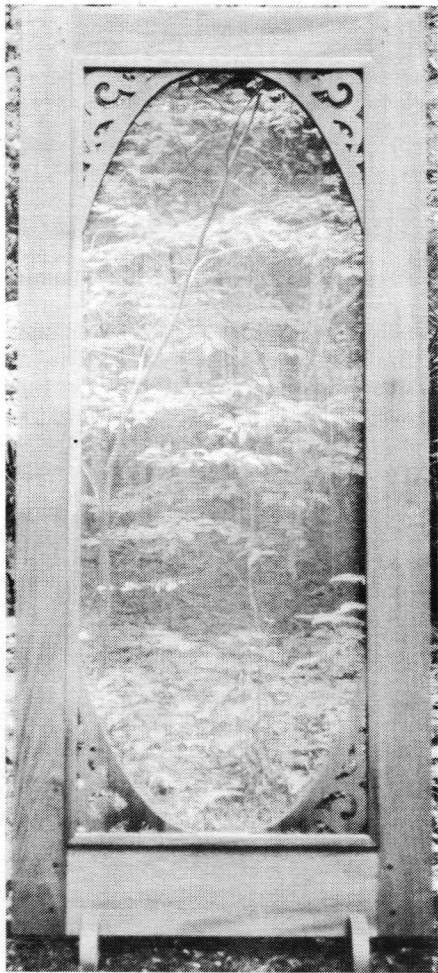

The Amherst screen door (style #128) from TOUCHSTONE WOODWORKS. Write in No. 784

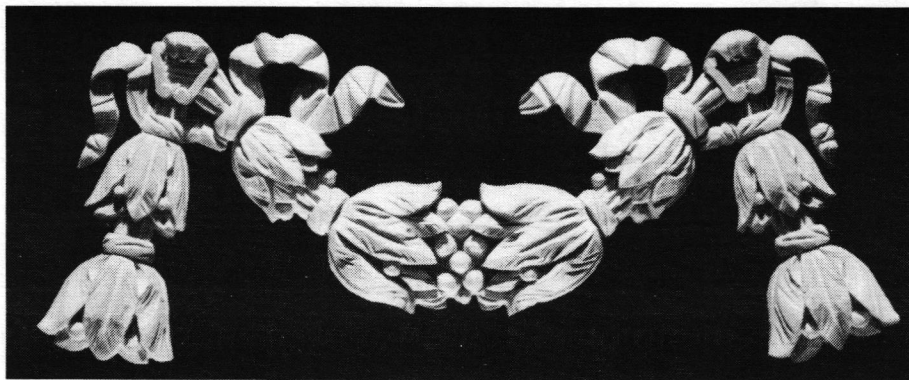

American Victorian swag reproduced in applique by RON WIENER, WOOD-CARVER. Write in No. 509

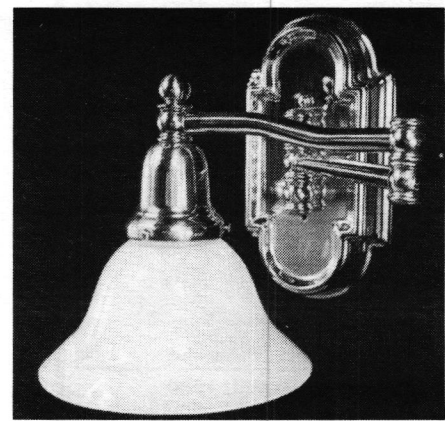

Model no. MSW-2 wall-mounted lamp with movable arm, made by ROY ELECTRIC Co. Write in No. 43

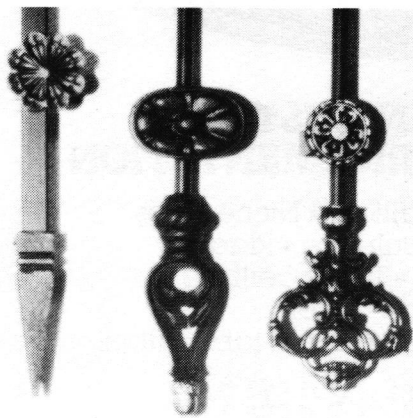

Shown above is STEPTOE & WIFE ANTIQUES, LTD.'s line of drapery accessories: Cast iron finials, rosettes, and rods, available in pewter, black and antique gold or copper finishes. Write in No. 47



RICHARD THIBAUT, INC., has just introduced "Balloon Festival," a four-panel wallpaper mural which covers 6 ft. 9 in. of linear wall space, and is available in four color versions. Write in No. 42



15 ft. Victorian gazebo from VIXEN HILL. Write in No. 710

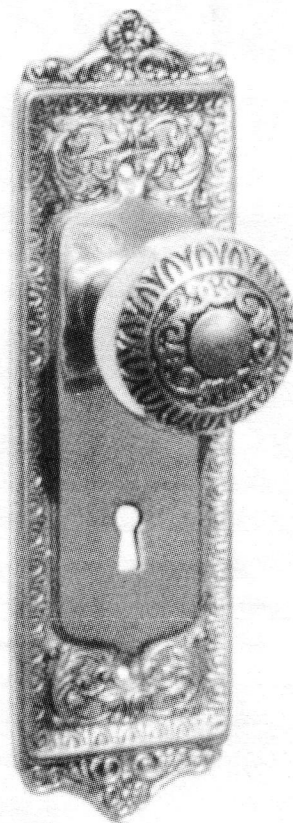

Cast brass doorknob and plate by HARDWARE PLUS. The plate is slightly oversized to cover pre-drilled 2-1/8 in. borings. Write in No. 652

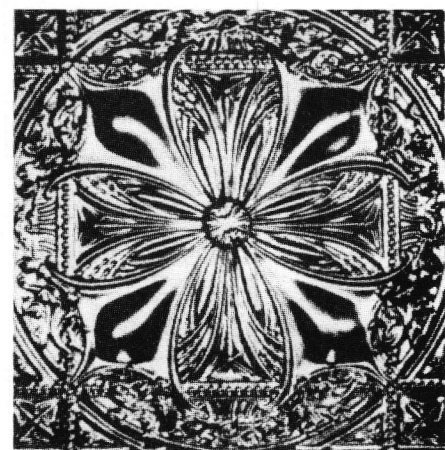

This floral metal ceiling square is available as a lay-in tile (24 X 24 in.) or as a multiple plate (24 X 48 in.) from CHELSEA DECORATIVE METAL CO. Write in No. 19

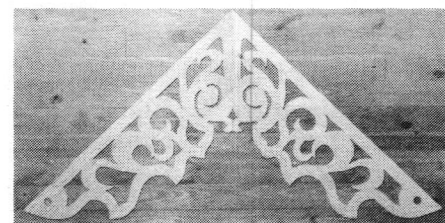

Gingerbread gable ornament by SILVER CREEK MILL. Write in No. 455

New Solid Brass "TGIF" Mini-Frame Custom Door

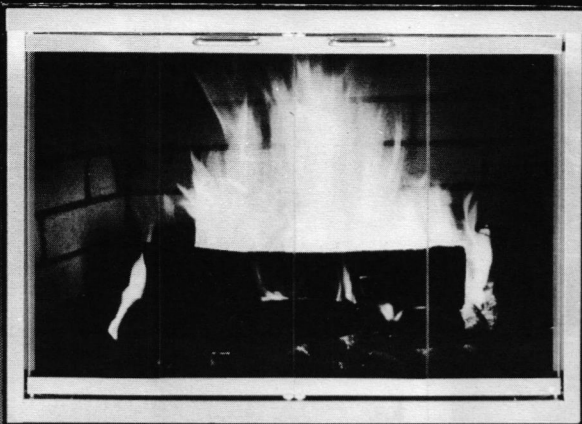

- "Track & Glass In Frame" Offers More Glass and Full View of Fire
- Lacquered Solid Brass on 7/8" Full Strength Tubular Inner Frame
- Customized for Inside Fits or Overlaps -- Choice of Finishes
- Bronze, Clear or Smoked Glass Available -- All Float Mounted
- Free, Full Color Consumer Literature, Resale Support
- Thermo-Rite Quality Made in USA for Over 45 Years

Thermo-Rite®

The Originators of
TEMPERED GLASS FIREPLACE ENCLOSURES
P.O. Box 1108; Akron, OH 44309; (216) 633-8680; FAX (216) 633-8701

WRITE IN NO. 523

20 Years of Energy Saving Lighting!

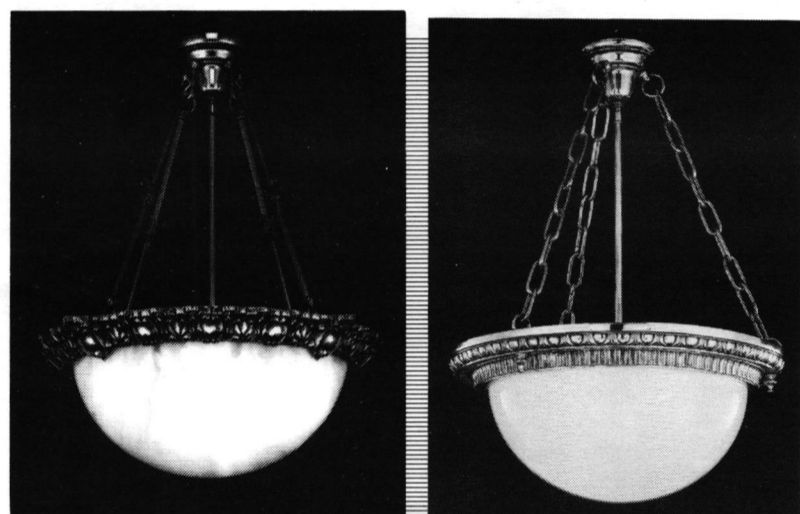

THE ORIGINAL CAST™ LIGHTING



A Division of Art Directions, Inc.

6120 Delmar Blvd. • St. Louis, MO 63112 • 314-863-1895

WRITE IN NO. 436

Push Button Light Switches

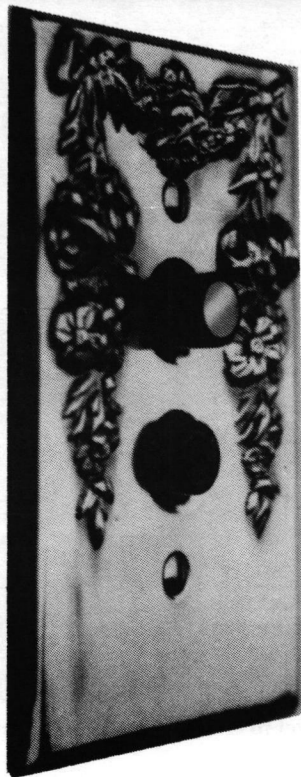

In
Single and Three Way
New Push Button Switch
Dimmer

Solid Brass cover Plates
Decorative and Plain

- Also In
- Chrome
 - Brown
 - Ivory
 - Oak

For Color Brochure
Send \$1.00 to:

Classic Accents
Dept. TB, P.O. Box 1181
Southgate, MI 48195

WRITE IN NO. 75

The Finest Authentic Decorative Hardware

By
bouvet™
Unique Designs For Unique Homes

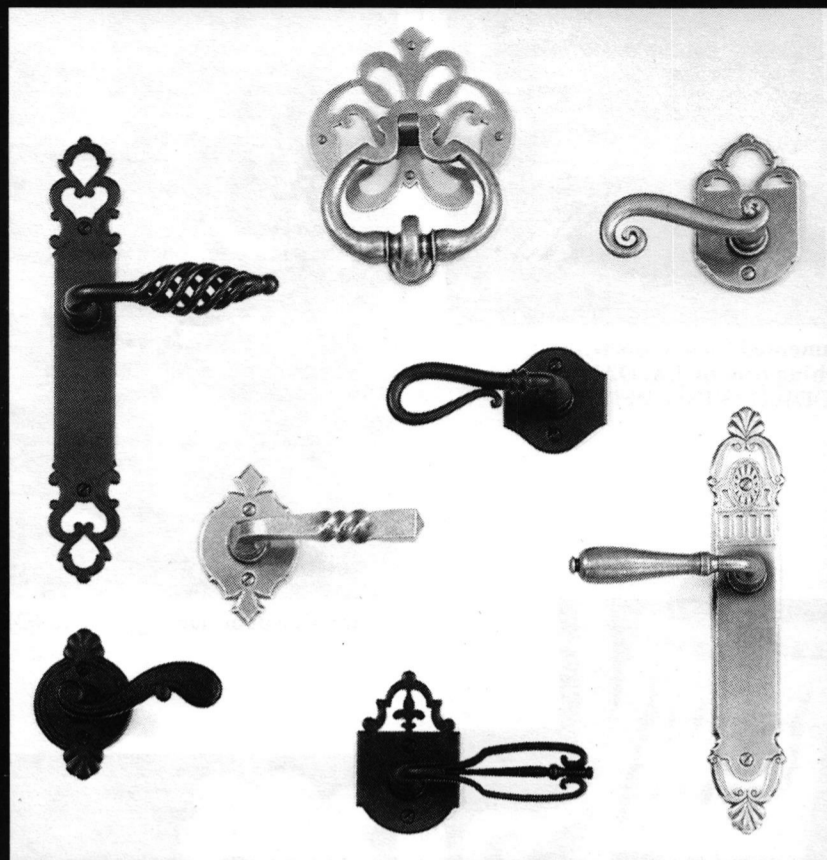

For the Nearest Authorized Showroom, Please Fax or Write To
Bouvet U.S.A., 87 McLea Court, San Francisco, CA 94103
FAX (415)864-0372

WRITE IN NO. 162

WE CAN DO THAT!

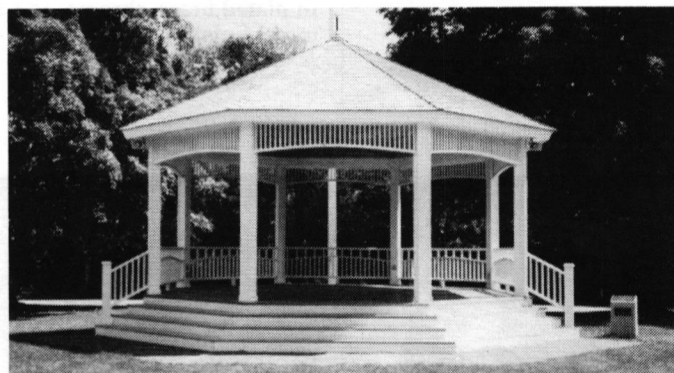

LARGE OR SMALL / CUSTOM OR STANDARD

Let Wood Visions build the structure of your dreams! Choose from our line of quality Cedar Gazebos. Or let us build that one-of-a-kind piece. Gazebos are how we started, but we may now satisfy all your landscape building needs with our modular construction and design services.

- Gazebos
- Arbors
- Custom Fencing



- Bandstands
- Footbridges
- Custom Experts

Choice of the P.G.A. for the 1991 Ryder Cup
Box 815, Derry, NH 03038 603-595-9663 800-628-1101

WRITE IN NO. 987

The Antique Hardware Store

Over 5,000 items of reproduction plumbing fixtures, builder's hardware, and many other period fittings.

See our ad on page 79!

- Historic Hardware •
- Historic Lighting •

Largest selection of historically accurate hardware and lighting fixtures in the U.S. Designs range from 18th century to early 20th century.

• See our ad on page 80!

VICTORIAN REVIVAL PRODUCTS

For more information on these companies, consult the Sourcelist on pp. 42-56.



Ornamented flower box with matching trim by J.A. DAWLEY WOODWORKING. Write in No. 420



Distinctive door hardware by KNOBS & KNOCKERS. Write in No. 775

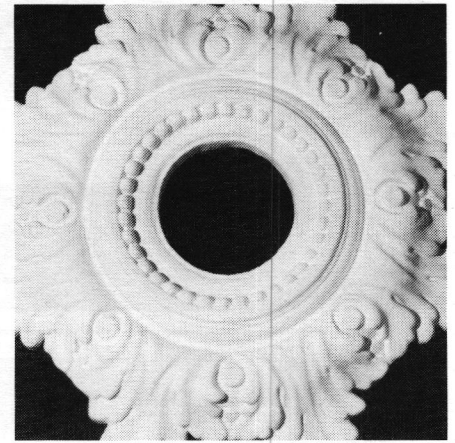

Acanthus leaf ceiling medallion from PLASTER CAST DESIGNS. Write in No. 480

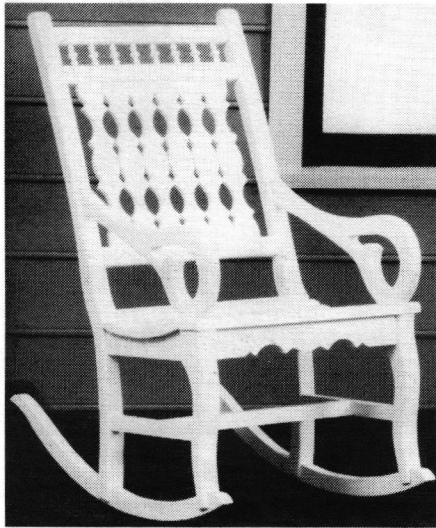

Hardwood rocking chair treated with wood preservative and finished in high gloss white enamel, available with other porch furniture from THE OLD WAGON FACTORY. Write in No. 780



White enamel wash basin filler from the Colore/Classica Series by WATERCOLORS. It is also available in plated brass, chrome, and 10 other metal finishes.

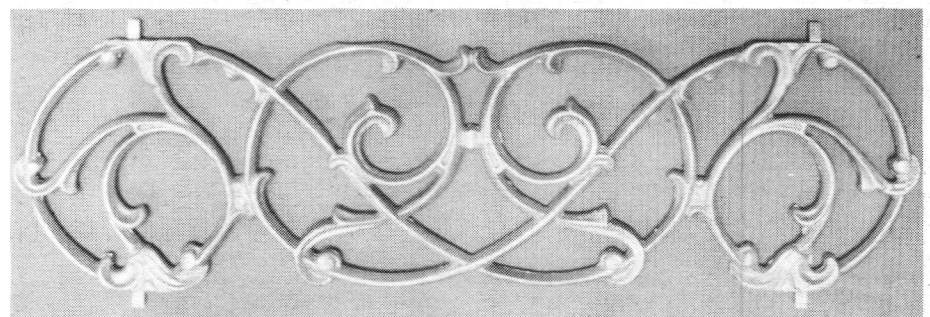

Model no. 527 is one of the many Victorian castings available in aluminum from ALLOY CASTINGS. Write in No. 468



REFLECTIONS STUDIOS produced these richly detailed and beautifully executed window panels. Write in No. 793



LANGHORNE CARPET CO. copied a drum-print velvet to create this replacement carpet in the James Lorah House in Doylestown, PA.

Manufacturers' Prices of Affordable Elegance

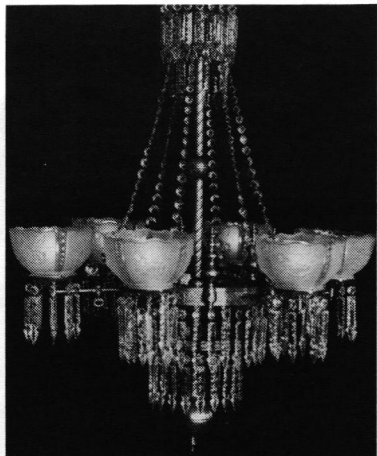

Elegant and Authentic copies of Victorian chandeliers and sconces of solid brass—hand polished—with Venetian spear point prisms and festoons; gas reproductions (wired). We are the designers and makers. 100 page illustrated catalog; Victorian ones in color. Also genuine Austrian Swarovsky Strass chandeliers and sconces. Catalog \$3.50 (1st class mail) 1-919-623-6188.

KING'S CHANDELIER CO.
P.O. Box 667 - Dept. TBV/7
Eden, N.C. 27288

Introducing...The Grand Pavilion.



The Grand Pavilion is monumental in concept and scale — three stories high, 100' from end to end, 1400 SF under roof ★ Here is an elegant solution for designers seeking a concert stage, open-air dining or dancing area, theme park entrance/ticketing/traffic flow regulator, VIP viewing platform, formal reception facility,

marketplace, town center arena, or major focus of a park or garden ★ Its three-tiered cathedral ceiling creates a ceremonial atmosphere for weddings and celebrations of every description ★ On site assembly by non-carpenters in 120 man-hours ★ Call for complete brochure or video.

VIXEN HILL GAZEBOS ★ MAIN STREET, ELVERSON, PA 19520 ★ 800-423-2766

WRITE IN NO. 710

BLOCK-PRINTED WALLPAPERS

Authentic 18th & 19th century papers hand-printed from antique pearwood blocks



The Classic Revivals Collection contains the finest historic wallpapers from the world's most distinguished manufacturers. The papers are accurate and authentic in every way, including method of manufacture. Among the firms we represent are Mauny Papers of Paris and Silvergate Papers of London—among the few remaining firms that make

only block-print papers. In addition, we carry a wide selection of other historical-lym accurate papers from the 18th and 19th centuries—and have expertise in museum work and custom reproductions. Call or write with your requirements.

Classic Revivals, Inc.

1 Design Center Place, Suite 545, Boston, MA 02210
(617) 574-9030 FAX (617) 574-9027
—TO THE TRADE ONLY—

WRITE IN NO. 610

Antique Builder's Hardware

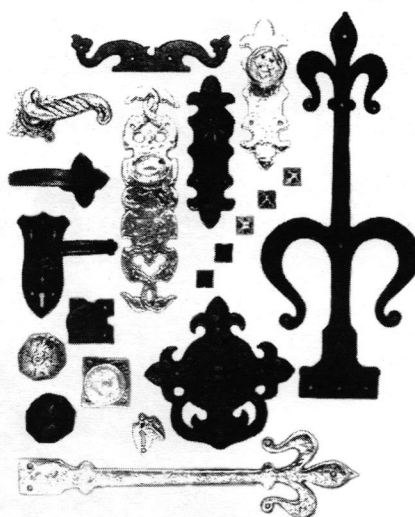

Handmade in England since 1855
Iron • Armour • Brass • Bronze • Rust

Lever Handles • Ring Handles • Sliding Bolts • Coat Hooks • Push Plates • Keyhole Escutcheons • Gate Latches • Grilles • Switch Plates • Door Knobs • Hinges • Door Pulls • Windows Fittings • Cabinet Hardware • Letter Boxes • Knockers • Bell Pulls • Lamps

Compatible Locks and Latches with various backsets and functions

Free Folder

Illustrated 150 Page Catalog
\$15.00 sent by UPS



MAGUIRE IRON CORPORATION

CARSON CITY, NEVADA 89701
ANTIQUE DESIGN HARDWARE
215-22ND STREET • RICHMOND, CALIFORNIA 94801 • TEL (510) 234-7569 • FAX (510) 232-7519



WRITE IN NO. 760

CUMMINGS STUDIOS

Tradition and Innovation in Stained Glass
• Restorations and New Commission •

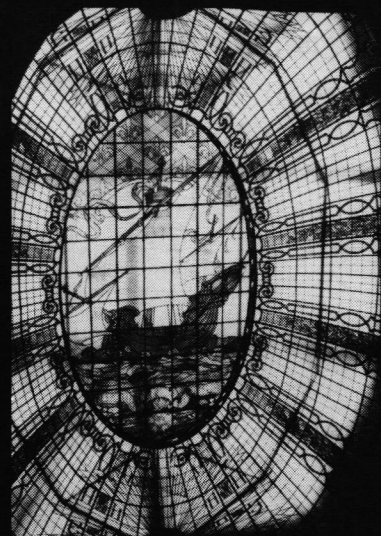

Since 1922, Cummings Studios has been a leader in the restoration of stained glass. Perhaps more than any modern American studio, we have been honored to take part in the restoration of the gilded-age masterworks of LaFarge and Tiffany . . . of the celebrated windows of the Gothic Revival . . . of panels from virtually every period in the history of the medium.

In addition, our studio commissions for new designs include government buildings, offices, shopping malls, banks, hotels, residences, and religious buildings. Our designer portfolio system offers our clients the opportunity to fully explore the unique possibilities of the medium.

Our project roster includes some of the most important restorations and new commissions awarded in recent years. Call or write for our client list and to discuss your project.

Neiman Marcus
San Francisco, CA

Cummings Studios P.O. Box 427
North Adams, MA 01247-0427
(413) 664-6578 FAX (413) 664-6570

WRITE IN NO. 316



THE CAMEO BASIN
From the Traditional Collection

APPROPRIATE FOR PERIOD RESTORATION OR RENOVATION

PRICED AT \$375

Send \$2.00 for full color portfolio



CHRISTINE BELFOR DESIGN LTD.

177 East 87th St. Studio 402 • New York, NY 10128
Tel/Fax: (212) 722-5410

WRITE IN NO. 351

VICTORIAN REVIVAL PRODUCTS

For more information on these companies, consult the Sourcelist on pp. 42-56.

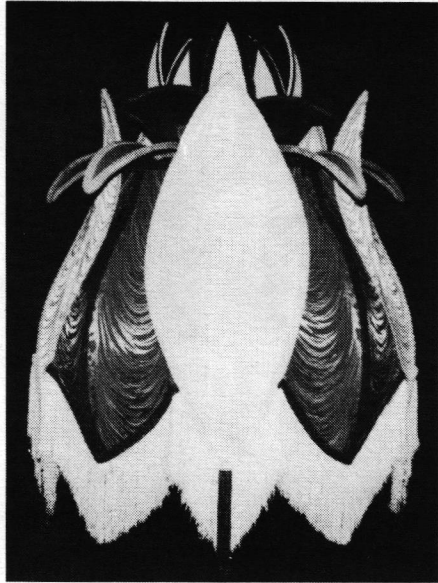

Model no. 143 measures 24 in. at the bottom and is 26 in. H. LAMPSHADES OF ANTIQUE. Write in No. 275



"Rose Trellis," c.-1890-1910, was reproduced by ZINA STUDIOS for Mrs. Vanderbilt's room in Kingscote, Newport, RI. Write in No. 467



Six arm gas-style solid brass chandelier from BRASS REPRODUCTIONS. Write in No. 622



Porcelain beaded pillow toilet set available from MAC THE ANTIQUE PLUMBER. Write in No. 813



Victorian Gothic Revival transfer tile by DESIGNS IN TILE. It is 6 X 6 in., sepia on creme. Model no. GR-6. Write in No. 25

Where can you find...

OVER 2500 lots of ARCHITECTURAL EMBELLISHMENTS, FINE ANTIQUES AND COLLECTIBLES INCLUDING: EXQUISITE BRONZE, GOLD & CRYSTAL CHANDELIERS; SCULPTURE & STATUARY IN STONE, MARBLE & BRONZE; STAINED GLASS WINDOWS AND CEILING DOMES; MARBLE, STONE & WOODEN MANTELS; FINE FURNITURE & DECORATIVE ARTS; BACKBARS AND SALOON DECOR; CAROUSEL HORSES, BARBER CHAIRS, JUKEBOXES, 50s & 60s MEMORABILIA?

A Unique
No Minimum, No Reserve
ANTIQUA AUCTION
Sept. 18 & 19

Only at Red Baron's - The Source!

For a FREE catalog that can be used as a valuable sourcebook, contact:

Red Baron's Dept TB
6450 Roswell Rd.
Atlanta, Ga 30328
(404)252-3770 FAX (404)257-0268

WRITE IN NO. 989

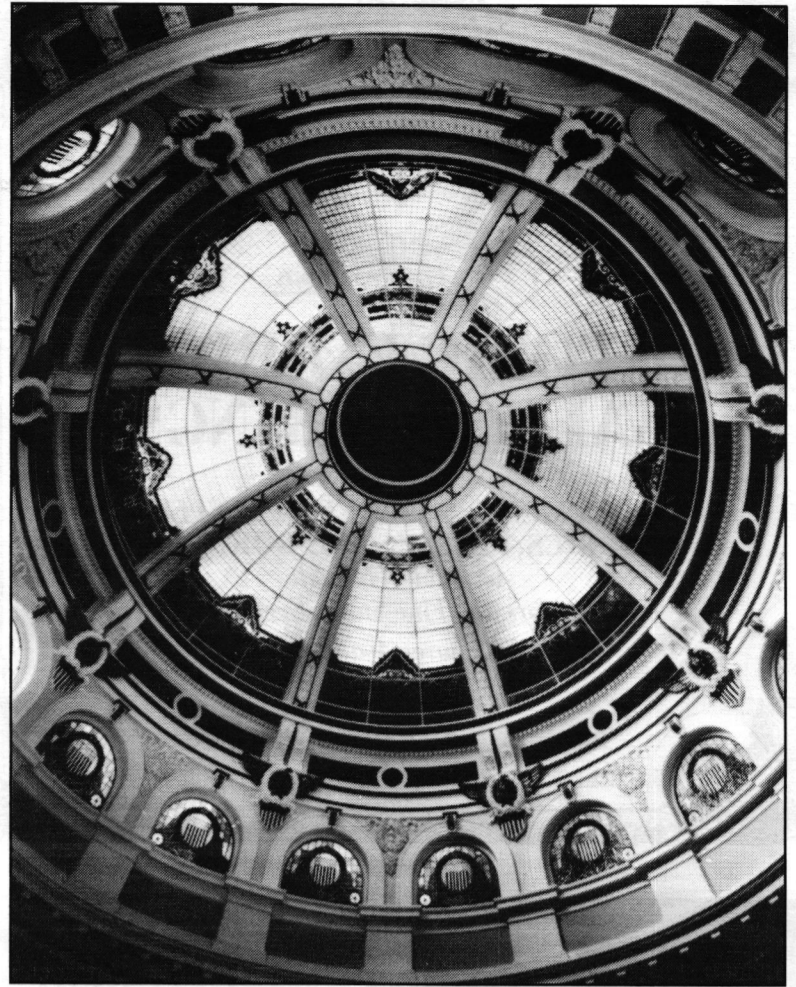

REFLECTION • STUDIOS

RESIDENTIAL & COMMERCIAL
STAINED GLASS ART & RESTORATION

1418 62ND ST. EMERYVILLE, CA 94608
(510) 652-4884

SAN MATEO COUNTY COURTHOUSE RESTORATION

WRITE IN NO. 793

BRASS REPRODUCTIONS



Manufacturers of Solid Brass
Victorian Lighting

Send \$8.00 for 44 page full-color catalog; refundable.

9711 Canoga Avenue • Chatsworth, CA 91311 • (818) 709-7844

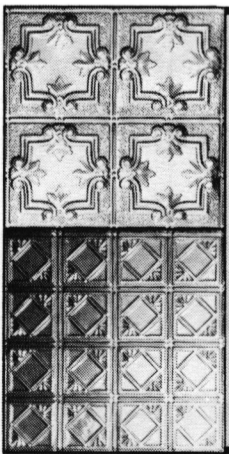

WRITE IN NO. 622



Buy the original - not an imitation
TIN CEILINGS

- 25 Patterns in 2 ft. x 8 ft. and 2 ft. x 4 ft.
- Lay-in panels in 2 ft. x 4 ft. and 2 ft. x 2 ft.
- Brass & copper-plated patterns in 2 ft. x 4 ft.
- 12 cornice moulding styles
- 2 ft. x 2 ft. center medallion
- Fast and easy installation
- Shipped anywhere
- Send \$1 for brochure

AA ABBINGDON AFFILIATES, INC.
Dept. TB, 2149 Utica Ave.
Brooklyn, NY 11234
(718) 258-8333

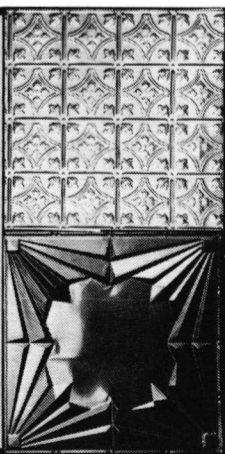

WRITE IN NO. 892



Sunflower™ Showerhead

- Feel cleaner -- more exhilarated
- Restore old country charm
- Install into standard plumbing

8" Chrome Showerhead - \$100
Brochure & installation tips available

EXCLUSIVELY FROM
Sunflower Shower Co.

PO Box 4218 - T
Seattle, WA 98104
(206) 722-1232
FAX (206) 722-1321

WRITE IN NO. 294

Lampshades of Antique
Dept. 21, P.O. Box 2, Medford, OR 97501



96 styles \$35-\$95 • Phone (503) 826-9737
We can recover your frame. Catalog \$4

WRITE IN NO. 275

Alloy Casting

3900 Peachtree Road, Mesquite, Texas 75180

Alloy Casting has been designing and manufacturing top quality custom aluminum castings for fifty years.

Architects and commercial designers look for only **superior custom work** and with Alloy Casting, they have it every time. By staying attentive to our customers' needs and wants we are able to **design custom work** that is second to none.

At Alloy Casting we use our vast resources to go from your concept or idea and **make it a reality.**

Whether using our in-house personnel or calling on well established and recognized sub-contractors, **Alloy Casting** will work with you to make your dream come true and all at a fair price.

Call us toll free at:
1-800-527-1318
or FAX to 214-557-4727
and we'll send you a free brochure or answer any questions you may have.

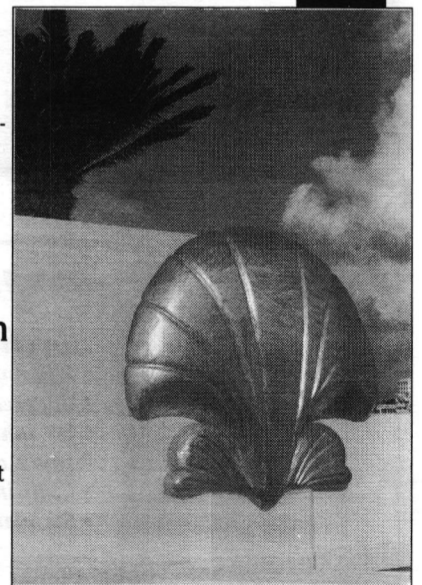

4' x 4' Seashell used in a beach front development

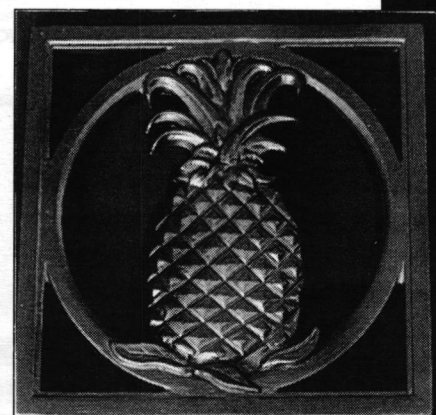

Pineapple plaque used in a Hawaiian hotel

Creativity that's custom-cast.

WRITE IN NO. 468



Thibaut
WALLCOVERINGS AND FABRICS SINCE 1886

HISTORIC FABRICS & WALLCOVERINGS

WITH
DOCUMENTED, SCREEN PRINTED FABRICS, FRIEZES AND BORDERS

Available Through
Decorators and Fine Stores Everywhere

Brochures Available

RICHARD E. THIBAUT, an RPM Co.
705 S. 21 ST., IRVINGTON, NJ 07111 (201) 399-7888

WRITE IN NO. 42

Bopas

- Murals
- Faux Finishes
- Wall Glazing
- Gilding

30 Ipswich Street, Boston, MA 02215
Phone and Fax (617) 236-4919

WRITE IN NO. 257

RESTORATION MILLWORK

- + Custom Mouldings
- + Windows/Doors + Victorian Etched Glass Panels + Casework
- + Stairwork + Wainscoting

Spoon River Millwork
P.O. Box 383 • London Mills, IL 61544
(309) 486-3745 FAX (309) 486-3747

WRITE IN NO. 853

HISTORIC WALLPAPERS
1770's-1920's

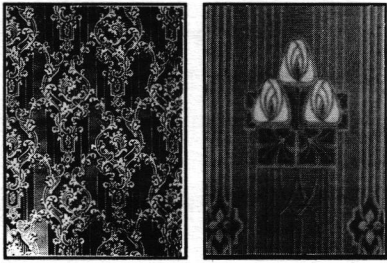

Send for information and a complete sample pack of wallpapers and borders in each of the following ranges:

GEORGIAN/FEDERAL COLONIAL REVIVAL
18 Samples \$5.

VICTORIAN
14 Samples \$5.

ARTS AND CRAFTS/EDWARDIAN
16 Samples \$5.

CHARLES RUPERT
THE SHOP

2004 OAK BAY AVE. VICTORIA, B.C. CANADA V8R 1E4 (604) 592-4916

HISTORIC TILES
VICTORIAN EDWARDIAN



Sets, singles, printed, moulded, florals, fish, galleons, numerals and plain field tiles for fireplaces, bathrooms, kitchens and more. For colour photos and design information send \$5.00.

Splendid Items for Traditional Homes
CHARLES RUPERT
THE SHOP

2004 OAK BAY AVE. VICTORIA, B.C. CANADA V8R 1E4 (604) 592-4916

FAUX Effects

FINE DECORATIVE FINISHING TRAINING STUDIO

FAUX EFFECTS offers classes in the field of decorative and faux finishing using the latest technology in methods and products. No oils or glazes. Simple water clean-up.

5 DAY INSTRUCTION IN:

- Marble, Artistic Marble, Stone
- Designer Wall Finishes
- Fine Furniture Finishing

Olde World to Contemporary

For Information (407) 778-9044
1613 10th Avenue
Vero Beach, FL 32960

INDUSTRY FOUNDATION MEMBER ASID

WRITE IN NO. 469

PVC LATTICE
Porches, Fences, Gazebos, Arbors

- Will not chip, splinter, rust, or crack
- Cuts readily with hand or power saw
- UV inhibitor retards fading and mildew
- Joints chemically welded
- Fully integrated color
- Standard sizes are 4'x8', 2'x8', and 2'x4'

Burton Woodworks
4290 ALATEX RD., MONTGOMERY, ALABAMA 36108
(205) 281-0097 (800) 489-0097

WRITE IN NO. 200

Barber METALCRAFT

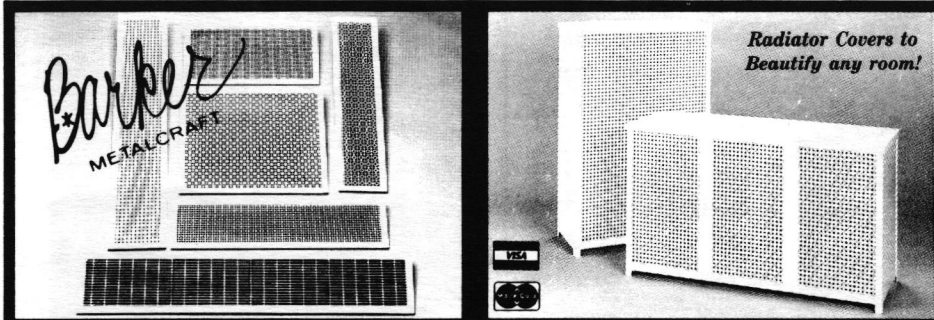

Radiator Covers to Beautify any room!

- Radiator Covers Custom Made To Your Measurements •
- Drop-In Grills • Flat Grills • Grills With Border • Convector Grill Covers •
- Custom Fabricated To Your Specifications • Call For Free Catalogue •

1701 W. BELMONT - CHICAGO, IL 60657 (800) 397-0129 / (312) 248-1115 FAX: (312) 929-2281

WRITE IN NO. 767

Nowell's, Inc.
A TRADITION OF FINE LIGHTING

TRADITIONAL QUALITY for TRADITIONAL BUILDINGS

Nowell's has offered durable, historically accurate fixtures to major institutions and private homes since 1954. Our Catalog fixtures and custom creations offer a variety of styles: Victorian and Craftsmen, Deco, and Neo-classical, each made-to-order to your specifications.

For a free information package, fax or write to the address below. For a complete catalog, send \$5.00.

Nowell's, Inc.
P.O. Box 295, Dept. TB
Sausalito, CA 94966
(415) 332-4933
FAX 415-332-4936



WRITE IN NO. 618

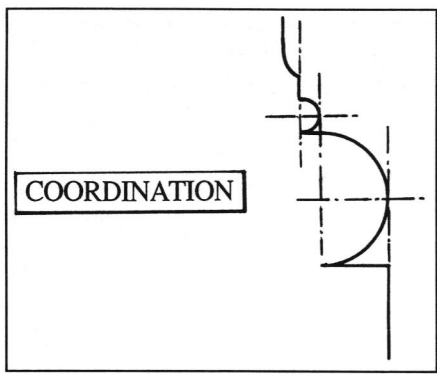

Figure VII

be successful in certain cases. In Fig. VI we have a convex *echinus* followed by a convex bead, and the combination works perfectly well. But almost always you want to avoid the literal repetition of profiles one after the other.

COORDINATION: In classical architecture, locating moldings relative to each other is not a free-for-all, but involves coordinating individual parts to make an ordered whole. This is usually attained by means of geometric alignments (Fig. VII). For instance, when a *torus* is set over a *plinth*, its outermost point is typically aligned with a vertical plane extended up from the face of the flat member. A vertical axis is then

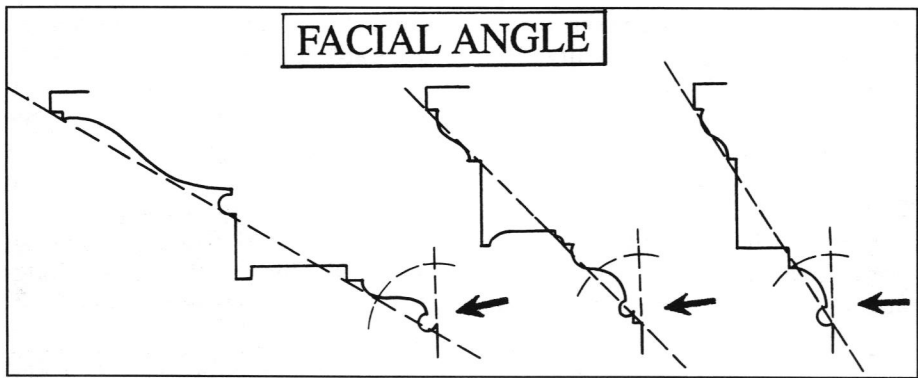

Figure VIII

passed up through the geometric center of the *torus* to locate the tangent point of the half-round bead immediately above. In turn, another vertical axis from the center-point of the bead establishes the face of the fillet which sits upon the bead, and so on.

FACIAL ANGLE: Another important alignment is the *facial angle* — the incline off the vertical at which both individual moldings and molding groups will be pitched. It's important to maintain a consistent facial angle throughout a molding sequence; otherwise, the parts will appear disconnected because light will fall on them at unequal angles of incidence. At various times in classical design, we find facial angles anywhere from 30 to 60 degrees (Fig. VIII). Differing explanations have been offered for these variations, such as the sharp angle of the sun in the Mediterranean climate requiring a steeper pitch for proper shadow effect.

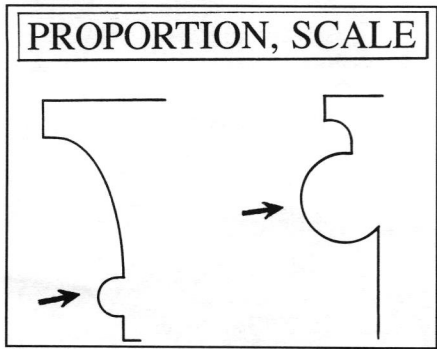

Figure IX

PROPORTION & SCALE: Both of these issues must be satisfied in molding design to achieve a harmonious whole, both in the relation of the profiles to their context, and to each other. The profiles on the left of Fig. IX are proportionate and internally well scaled, the dominant *cavetto* clearly distinguished from the minor moldings. The same profiles on the right, however, reverse the major and minor in size. Consequently, the whole combination becomes confused and no longer a valid measure of scale, since there appears to be two different measures of scale at work.

REDUCTION/AMPLIFICATION: While it's illogical to have two disparate scales present within a particular molding sequence, it's not unusual to have varying scales in moldings belonging to different features of the same building or space. In fact, in structures of any complexity one is often compelled to use moldings of diverse scales. The challenge is to adeptly bring about what I call the *reduction* or *amplification* of scale where they meet.

In Fig. X, the *torus* and *plinth* moldings that articulate the base of the building are hefty in size and scale, because they are in proportion to the overall height of this very tall urban structure. The moldings of the door surround, on the other hand, are literally reduced in size so they can relate to a more human scale appropriate for a door. Equally important is how

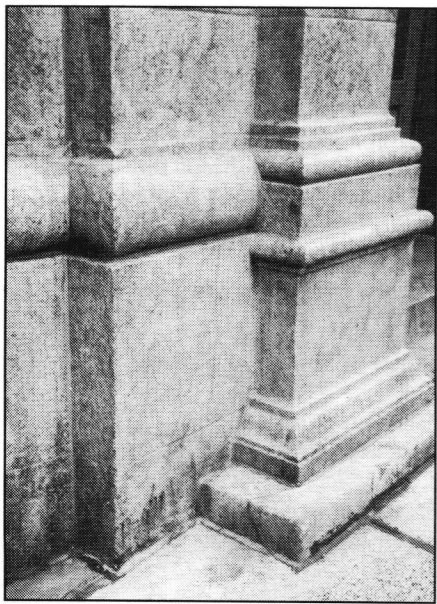

Figure X

they come together. Notice that the overall height of the step and pedestal element in the doorway is contained within the bottom flat member of the building's base, and how the greater number of divisions at the door element, versus the single division in the base, conveys the reduction in scale. The same happens immediately above the big flat, where the height of just a single large *torus* is given over to both a *torus* and a *plinth*.

OCULAR RECTIFICATION: Another instance where one might manipulate the sizes of profiles concerns the position of moldings relative to the eye. These revisions, known as *ocular rectifications*, are intended to restore the profile to its normal appearance by counteracting distortions inherent in human perception. These distortions may be caused by such variables as the vantage point of the observer, available lighting, even the color of the moldings. The issue of perspective is especially critical on the interior, where one rarely can stand as far back from a vertical surface as on the exterior. To illustrate, in Fig. XI if the profile stands roughly level with the eye, you would probably construct the various moldings according to regular geometry (center). But if this same sequence of profiles is to be located near the floor, you might make adjustments because the viewer will always be looking down on it. For instance, you could re-configure the *scotia* so more of it is visible, and less is concealed by the overhanging element. The face of the *fillets* may also be turned, and even the half-round could be given an egg-like contour to restore some of its underside to view (left).

Similarly, should the profile be placed overhead, then other changes would be appropriate — like raising the over-all height of the member to compensate for the effect of foreshortening (right).

LIGHT & SHADE: Moldings on the outside of a building are almost always illuminated by direct sunlight. Interior moldings, on the other hand, are usually illuminated by indirect reflected light or electric lighting. To compensate for the general weakness of interior light, you might want to make still more adjustments, since moldings only exist to the degree that they produce effective planes of light and shadow. This is especially crucial on the interior where, in the absence of external miters, you must rely on the tonal play of shade and shadow to define the profiles at hand.

Space doesn't permit us to go into detail on the dynamics of light. We can make a few basic points, however, by comparing the *ovolo* and *echinus* profiles (upper l. and middle r. of Fig. XII).

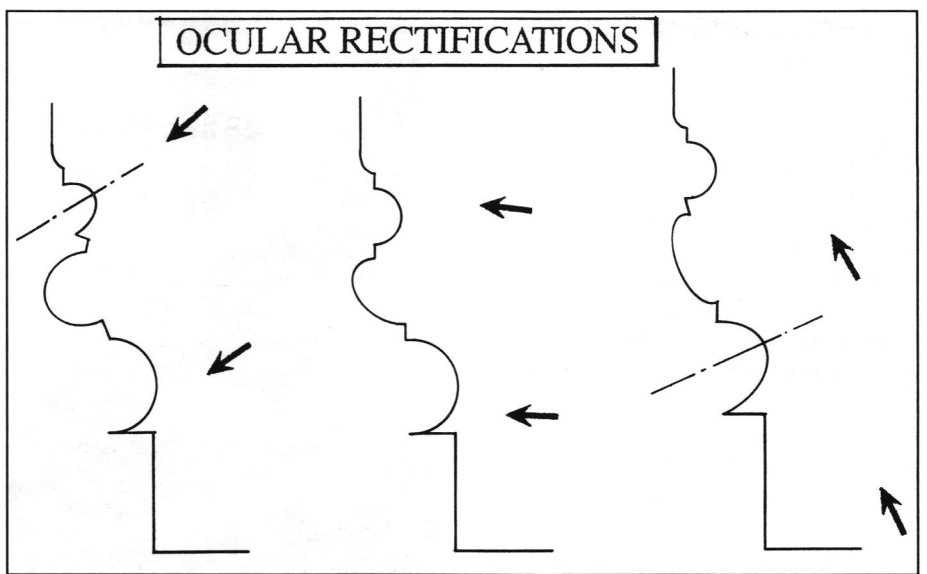

Figure XI

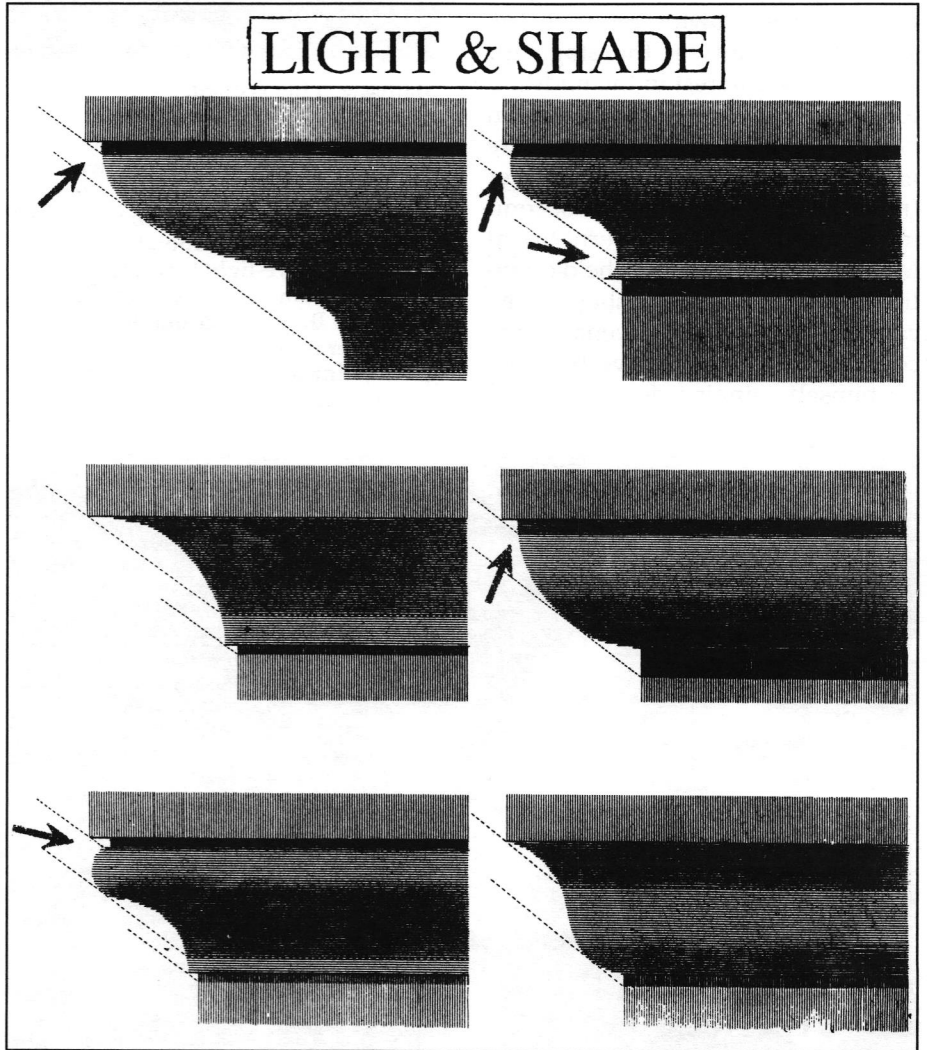

Figure XII

Assuming light falls in parallel rays from above, the gradation from light to dark on the *ovolo* will occur in uniform increments because all points along its surface are equidistant from its geometric center. With the *echinus*, the gradation is far more complex because it is constructed according to the non-circular geometry of the ellipse. An ellipse doesn't have geometric centers, and therefore — unlike the *ovolo* — its curvature is constantly changing, making the shift from light to dark more subtle and less monotonous than the *ovolo*.

Particularly noteworthy is the little highlight at the top of the *echinus*, known as *quirking*, which is where a curve returns upon itself at its ends. You can see it even more exaggerated in this *cyma reversa* (lower left of Fig. XII), which can also be made from portions of an ellipse. The *quirk* can add much to a molding, in addition to the light effects it produces. For instance, it creates greater contrast between curved and straight at the extremes of a molding, in contrast to the *ovolo*, where the profile assumes a vertical orientation just as it meets the adjacent *fillet*. The *quirk* also anticipates and makes a more organic connection between contiguous elements than does the rather abrupt perpendicular termination of the *ovolo* into the flat surface above.

CHARACTER: The differing qualities of the *echinus* and *ovolo* brings us to the question of *character*. The option of selecting one molding over another, as well as the opportunity of manipulating a molding type, suggests a wide range of effects is available to the designer.

Compare the two different door casings in Fig. XIII. At the top is a design that comes from the 19th-century American design manual, *Beauties of Modern Architecture*. The bottom example is taken from a 17th-century Italian building. In terms of architectural *character* they could not be more dissimilar. We have severity and simplicity versus elaboration and multiplicity; planar versus modeled; straight versus curved; orthogonal versus multi-directional; conventional versus occasionally non-conventional — all of which could describe the respective architectural traditions from which these moldings derive. Thus we come full circle back to an earlier statement about the classical system — that one can find the spirit of the whole in the smallest part. ♦

The Institute for the Study of Classical Architecture conducts formal classes for professionals who wish to develop their skills in classical design. For further information, contact: Donald M. Rattner, Director, The Institute for the Study of Classical Architecture, New York Academy of Art, 419 Lafayette St., New York, NY 10003. (212) 505-5300 (telephone); (212) 776-1170 (facsimile).

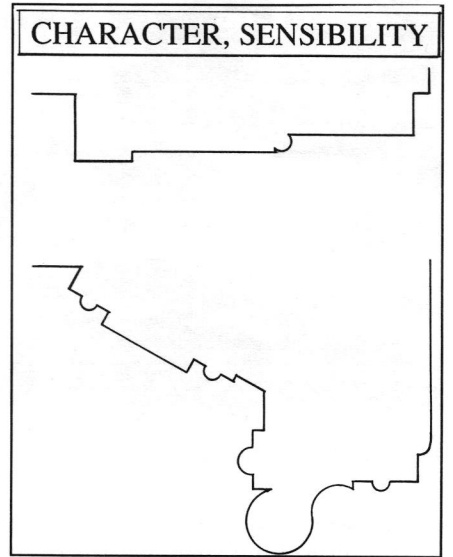

Figure XIII

C. DUDLEY BROWN
continued from page 5

military interiors around the globe. In his recollections, the job sounds like one grand lark: Borrowing military commanders' vehicles, living in officers' quarters, learning the tricks of real-world negotiation, working respectfully on historic buildings (the conservative military never entirely succumbed to modernism's charms), and resigning in frustration from a post as chief of interior design for the General Services Administration in 1964.

That move let C. Dudley Brown finally come into his own. He positioned himself with impeccable timing. Georgetown's return to respectability had set the stage for preservation interest in the mid-Victorian Capitol Hill district. Brown had bought an 1870 townhouse there in 1958 with his aunt, Ruth Spangler (now retired, once a director of communications for the International Monetary Fund). By 1965, he'd established a several-person shop in the carriage house and rejuvenated the complex into a giant advertisement for himself, winning dozens of local



Staircase at the Woman's Club in Richmond, VA, an 1858 mansion that had been misguidedly decorated for decades in Georgian style. Brown's overhaul included refinishing the walnut woodwork, replacing an incorrect newel post with an elaborate post, designing a five-light torchiere, installing Pompeiian-red carpet and gold-and-ivory Bradbury & Bradbury wallpaper in place of Williamsburg green paint, and trimming ornamental alcoves with gilt.



The facade of one of Brown's numerous Washington projects, this one in the Dupont Circle historic district.

commissions and two "Outstanding Restoration of the Year" awards from the Capitol Hill Restoration Society. A trip through the neighborhood with him elicits a stream of explanations of architectural errors undone: Original brick or German siding revealed, false Georgian entries stripped, lost brackets rebuilt, white paint and other "decorator shades" replaced by more suitable shades, inaccurate shutters torn away.

He quickly became a highly theatrical point man for the trend. A skim through his press clips of the '60's and '70's reads like a history of the Victorian Revival. According to one amazed reporter's 1969 description of a Victorian house restored and decorated by Brown, the result is "not Victorian in the manner of black horsehair sofas, drawn draperies and

dark furniture. Everything about the house is light and bright." "History is a Happening," explains an especially quaint 1969 headline for an interview with Brown. A 1970 article marvels at unrestored-Victorian-house prices jumping from \$11,000 to \$35,000 on Capitol Hill — and at how Brown's restorations in many cases "come out fancier than the houses were originally." A '78 meditation on the Victorian Society in America (Brown founded the Washington chapter in 1975) boasts that the members "have been put down, laughed at, ignored by style setters and trend-makers who prefer Danish modern furniture or Colonial architecture, who find the 18th century utterly admirable and the 20th century a definitive distillation, but who find the 19th century something of a joke Now Vic-

torian is in."

Brown has since lost count of the number of times he's lectured around the country and watched "eyes opening, light bulbs popping" with newfound Victorian consciousness. (But he's never forgotten the time he ad-libbed his way through a National Trust luncheon talk in Kansas City, Missouri, on Tracy Kidder's *House* after the author missed a plane, and performed so ably that only six of 288 attendees demanded refunds). Still, in becoming famous for stage presence, he has never taken on an overbearing design personality. The likes of *Architectural Digest* have never pursued him. "Our work's too livable for that," muses longtime office manager and associate Cindy Janke. Nor has Brown ever delegated much; his own fingernails are always worn-down battlegrounds and his tape measure is ever at the ready. He's renowned for happily crawling around clients' dustiest corners.

"He wanted to see the basement

first," says Joan Wells, co-owner of the Queen Victoria Inn in Cape May, New Jersey. "He shimmed around in there and said, 'This wall isn't original, this one is, this isn't,' and he turned out to be right about everything. He's been such a fountain of enthusiasm and real help." Clients not only return to him year after year, they take his arrangements with them when they move and recommend his services to their children. "He makes people happy," says Wilbur Monroe, a second-generation Brown customer and veteran of three Brown homes. "He's able to take the building blocks one has, eclectic as they may be, and make them look as if they all came from the same egg. The Victoriana is certainly a part of him, but it's not a requirement in his work."

Brown still finds outlets, of course, for historical-accuracy longings. Among his recent resume highlights: Baltimore's circa-1870 Mount Vernon Place United Methodist Church (where a 90-foot nave wall



A signature C. Dudley Brown room: Victorian, but not overwhelmingly so, with some original detail (the fireplace) and some undetectable additions (the mirror). The owners later took all the furniture with them upon moving to a one-story ranch house in Florida (Brown helped them drive down).

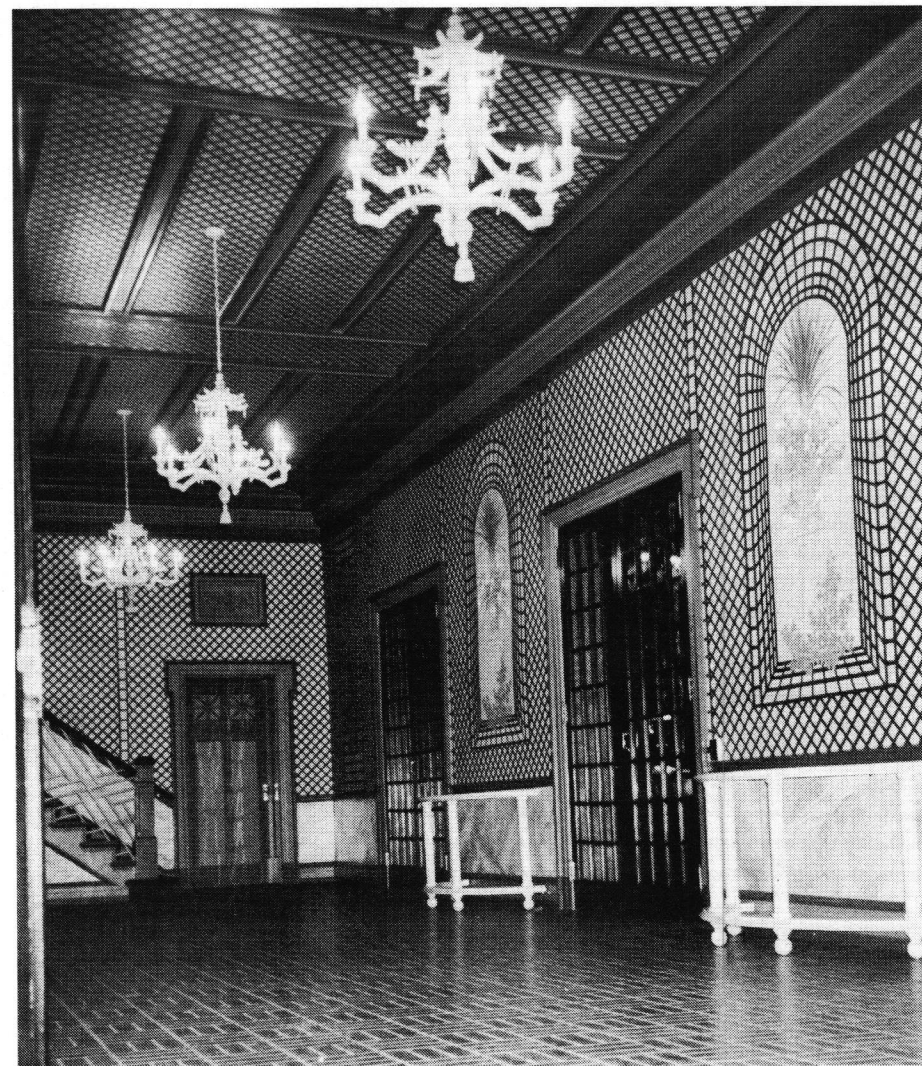

In place of the Woman's Club's bland green auditorium foyer, Brown finished the walls in trompe-l'oeil marble wainscoting and trellis, stripped the paint from the huge birch French doors, and refinished them in an original mahogany hue.

has regained its original painting in faux ashlar); showhouse rooms depicting a Victorian theater critic's study and a porch set for tea with Queen Victoria; and an 1858 women's club in Richmond, Virginia, where Brown recreated the correct Victorian appearance of all public spaces and enriched a Williamsburg-green 1916 auditorium with swaths of Bradbury & Bradbury Neo-Grec wallpaper.

And then, of course, there's his office on Capitol Hill, which he bought in 1989. More money and effort may never have been lavished on any other two-story five-room struc-

ture. The floor joists? They're half-new and all newly tied together, to render the brick exterior incapable of further sags. (Facade problems commenced 70 years ago, when the livery stable next door turned concrete-lined garage and swelled with the weight.) The staircase? A symphony of existing, copied, and retrieved pieces. Interior walls? Intricately fitted with closets, capped with reproduction ceiling medallions, abounding in Bradbury wallpaper and vintage paneling.

And that small circular medallion between the front windows?

Why, it's the ultimate symbol of a designer who has accurately foreseen the future since World War II. "It's a wooden lid for a shaving mug," says Brown. "I found it 25 years ago and hung onto it in that box I keep of all kinds of wooden ornament. I liked its shape, and I figured, someday, I'll need it." ♦



(Top photo - before) In the auditorium, skinny three-inch steel columns supported the balcony; a cornice section had disappeared to make way for a projection booth; unfinished gaps in the balcony railing posed safety hazards; French doors had been painted green, including the panes. (Bottom photo - after) Ionic columns now enclose steel columns; grillwork panels fill railing voids; the cornice has been in-filled; and the French doors are restored to original mahogany color.



Brown painting bricks on his c.-1885 townhouse-office; the original brick surfaces were hopelessly slathered with tar.

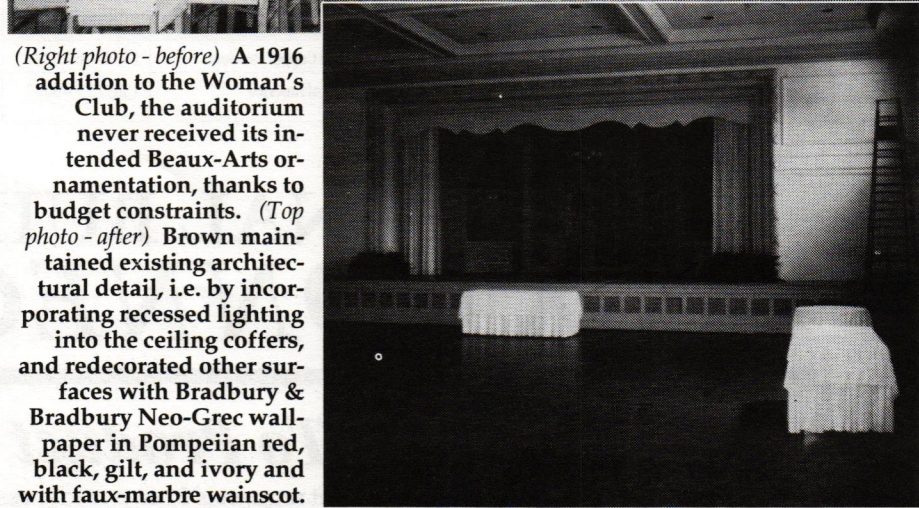
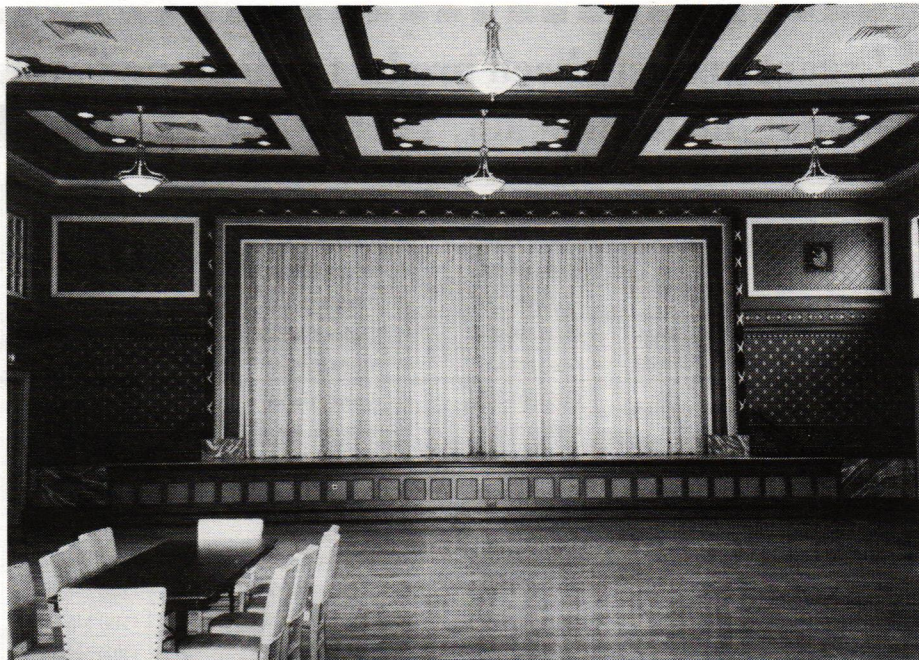

(Right photo - before) A 1916 addition to the Woman's Club, the auditorium never received its intended Beaux-Arts ornamentation, thanks to budget constraints. (Top photo - after) Brown maintained existing architectural detail, i.e. by incorporating recessed lighting into the ceiling coffers, and redecorated other surfaces with Bradbury & Bradbury Neo-Grec wallpaper in Pompeiian red, black, gilt, and ivory and with faux-marbre wainscot.



The nearly finished townhouse-office, with trelliswork disguising pipes, rebuilt windows painted original colors, and further sagging controlled inside by tied-together joists.

Urgent project? Need product info immediately? Just photocopy and fill out the form below. Then FAX it to any of the companies listed.

PG.	COMPANY	FAX NO.	PG.	COMPANY	FAX NO.	PG.	COMPANY	FAX NO.
67	A.A. Abbingdon	(718) 338-2739	51	DMS Studios	(718) 937-2609	59	North Field Restorations	(508) 948-7563
29	Abatron	(708) 426-5966	49	Enkeboll Designs	(310) 532-2042	51	Peters & Co.	(215) 739-9779
40	Allied Windows	(513) 559-1883	51	Ewing Restoration	(919) 228-8022	61	Polytek Development Corp.	(908) 534-5190
23	American Custom Millwork	(912) 888-9245	55	Fischer & Jirouch	(216) 361-0650	6	PRG	(301) 279-7885
17	Architectural Facades Unltd.	(408) 297-8014	45	Hardware Plus	(214) 271-9726	69	Reggio Register	(508) 772-5513
80	Ball and Ball	(215) 363-7639	17	Hennessy House	(415) 896-0940	51	Roy Electric	(718) 421-4678
68	Barker Metalcraft	(312) 929-2281	21	Historical Arts and Casting	(801) 974-5832	33	Schwerd Mfg. Co.	(412) 766-2262
57	Bathroom Machineries	(209) 728-2320	9	Kestrel Mfg.	(215) 286-5466	19	Smooth-On	(908) 604-2224
17	Big D Metalworks of Texas	(214) 638-2241	13	Lake Shore Industries	(814) 453-4293	55	Steptoe and Wife	(416) 530-4666
49	Bradbury and Bradbury	(415) 922-2872	70	Leitelt Bros.	(312) 734-0874	67	Sunflower Shower Company	(206) 722-1321
13	Brickyard	(816) 887-5757	6	Lynch and Sons	(203) 762-2999	51	Victorian Lighting Works	(814) 364-2920
55	Cassidy Company	(302) 629-7649	65	Maguire Iron Corp	(510) 232-7519	61	Vixen Hill Shutters	(215) 286-2099
25	Center Lumber Company	(201) 742-8303	40	Midwest Arch. Wood Products	(319) 323-1483	19	Vulcan Supply	(802) 878-4103
31	Chadsworth Columns	(404) 876-4492	19	Miller Sheet Metal	(301) 349-2322	45	W.F. Norman	(417) 667-2708
59	Conant Custom Brass	(802) 864-5914	28	Monarch Radiator Enclosures	(201) 796-7717	69	Wood Factory	(713) 863-7524
70	Copper Coatings & Patinas	(619) 689-9402	40	Mullane Copper Products	(508) 568-9227	40	Woodstone Windows & Doors	(802) 722-9528
45	Cumberland Woodcraft	(717) 243-6502	71	Nixalite of America	(309) 755-0077	6	Yazoo Mills	(717) 624-4420

TRADITIONAL BUILDING's F•A•X CONNECTION

The Fastest Path To Product Information

TO: SALES/MARKETING DEPT. (This urgent request is from a reader responding to your recent advertisement in TRADITIONAL BUILDING.)

FROM:

Your Name _____ Title _____

Company _____ Address _____

City _____ State _____ Zip _____ Date _____

Telephone _____ FAX _____ Type of Business _____

URGENT NEED. Please call or FAX immediately. Please mail Product Information as soon as possible. Here's a brief description of my project and the information I need:

vide an excellent sampling of Dresser's protean output. The designs, excellently reproduced, almost defy style categorization. Although he embodied the vigorous spirit of the late Victorian era, Dresser's designs transcend "Victorian." His creations draw on Egyptian, Japanese, Classical, Islamic, and other sources for inspiration. But all historical models are filtered through his inventive mind, so that the end result is something fresh, new — and powerful. Even viewed through the tunnel of 100 years, Dresser's creations still have the ability to astonish. — CL

The Not-So-Humble Brick

BRICKWORK, by Andrew Plumridge and Wim Meulenkamp. Harry N. Abrams, Inc.; 224 pp. Hardcover \$39.95.

It's hard to imagine anything more plebian than the brick, yet this humble clay object has been used to create some of the world's great architecture. Proof of the brick's inherent potential is dramatically portrayed through rich color photographs in this elegantly



A late Victorian building embellishment in carved and rubbed brick on the exterior of a London town house.

produced new volume from Harry Abrams.

The aim of the authors is to show construction excellence in brick and terra cotta all over the world . . . from 1400 BC to the present. Photographs ranging from the ziggurat at Ur to contemporary examples in England and America illustrate the ingenuity of builders through the ages in creating complex forms with simple baked clay blocks. In addition to photos of massive constructions, there are exquisite details of chimneys, entryways, windows, corbelling, and other ornamental brick elements. The text gives an extensive history of brick, while a technical appendix reviews the fundamentals of design, specification, and construction in brick. The authors were not in the employ of the Brick Institute of America, but brick manufacturers owe the authors a great debt for such an appealing portrayal of brick construction.

After poring over the photos in this book, anyone who isn't seized with the urge to design a great brick building simply isn't a builder. — CL

Division 17 - BOOK REVIEWS

EXQUISITE VICTORIAN DESIGN

VICTORIAN HOUSE BOOK, by Robin Guild. Rizzoli; 320 pp. Hardcover; \$50.

This handsome volume, originally published in England, was designed by the author as a primer for individuals who are restoring 19th-century houses. However, the book is not a how-to reference, but rather a visually rich portfolio of some of the most sumptuous interior residential architecture of the 19th century.

For the professional audience, the book provides a wealth of ideas for anyone doing 19th-century restoration — or designing neo-traditional residences. The photographs and accompanying text — insightful commentary on how social and intellectual trends affected the look of Victorian architecture and interiors — is conveniently organized into the various sections of the house that the designer must deal with, e.g., hallways, drawing rooms, dining rooms, kitchens, bathrooms, etc.

The book includes photographs of American houses, but the majority of examples are high-style English. The English photos capture fully developed and elaborated interiors, and as a result are a wonderfully rich source of

inspiration, either to adopt as is, or in simplified versions.

If you do any Victorian or neo-Victorian interior architecture and/or decoration, this book deserves a place on your reference shelf. — CL

VICTORIAN VISIONARY

CHRISTOPHER DRESSER, by Stuart Durant. Academy Editions; 144 pp.; Hardcover \$50; Softcover \$35.

Christopher Dresser (1834-1904) was a creative genius who transcended his time. In a period when Ruskin and William Morris were extolling the moral superiority of hand-crafted goods, Dresser embraced — and designed for — mass production. A prolific creator with enormous talent and energy, Dresser can be rightfully called the first modern product designer.

Wonderfully inventive and beautiful designs for coat stands, wallpapers, vases, tea sets, linoleum, furniture, glassware, metalware, ceramics, and dozens of other items poured from his studio. The aesthetic quality of the work was maintained at an amazingly high level . . . and was consistently true to Dresser's design triad of "Truth, Beauty, Power."

Durant's volume, while not encyclopedic, does pro-

FREE PRODUCT LITERATURE

These suppliers will send free literature about historical products to TRADITIONAL BUILDING's professional readers. Write in the appropriate number on the enclosed postcard — or use the form below.

Division 1 — PROFESSIONAL SERVICES

338. Restoration Congress — Aimed at the professional & trade audience. Concerns include: Preserving buildings, monuments & sites, antiques, decorative & fine arts, books, etc. Free brochure. **Restoration 93**
303. Preservation Books & Instruments — Books, instruments and products for preservation and restoration of architecture and objects. Consulting and training services. Free brochure. **PRG, Inc.**
930. Shipping Tubes — High quality shipping tubes for blueprints, mylar & vellum tracings, and storage. Over 30 sizes available. Free brochure. **Yazoo Mills**

Division 2 — SITEMARK

333. Garden Ornaments — Traditional items such as urns, jardinières, and statuary. Also offers restoration of lead figures. Free brochure. **Classic Garden Ornaments**
339. Custom Site Finishings — Classically designed benches in wood and metal; ash urns, planters, bollards & waste receptacles. Free brochure. **CSI Custom Structures**
118. Wooden Flagpoles — Hand-made wooden flag poles with classic square-to-octagon-to tapered round design. Select Douglas Fir, turned on custom lathe; white gloss finish. Free brochure. **Hennessy House**
Hand-Crafted Weathervanes — Large selection of handcrafted copper weathervanes; sizes for church steeples to small residential models. Large selection of garden ornament. Call (203) 762-8363. **Kenneth Lynch & Sons**
378. Outdoor Drinking Fountains — Period outdoor fountains and hydrants. Free brochure. **Murdock Fountains**
Elegant Aviaries — Complete with finials & cresting for Victorian designs; other styles have Southwest and post-modern influences. Call (918) 584-0856. **Wm. Bateman Ruffner & Co.**
990. Historic Garden Gates — Company specializes in the research and reproduction of historic wood garden gates. Free brochure. **The Timeless Garden**
987. Gazebos & Garden Furniture — Offers cedar gazebos from 10 to 30 ft. dia. Custom styling a specialty for town and corporate environments. Free literature. **Wood Visions**

Division 2 — MASONRY

244. Chimney Flue Liner — Poured-in-place, two-liner system; no-mess one-day process. System strengthens, insulates, seals & protects masonry. Dealers nationwide; free brochure. **Ahrens Chimney Technique**
152. Chimney Dampers — Damper replacement system for masonry fireplaces. Replaces worn out or rusted dampers, almost invisible when closed and saves energy. Free brochure. **Benson Chimney Control**
396. Antique Clinker Brick — Authentic, decades-old, unused clinker brick recovered from an abandoned brickyard. A unique building material available in limited quantities. Free brochure. **The Brickyard**
428. Chimney Cleaning & Restoration — Full-service company for residential, commercial, or industrial chimneys. Free brochure. **Certified Chimney Contractors**
208. Chimney Dampers — Damper is guaranteed non-restrictive, adaptable to round tops, resistant to freezing, and energy efficient. Free brochure. **Fireplace Technologies**
174. Flue Liners — Highly insulated Golden Flue liner has no seams to weaken at a later date. Loose bricks, voids and cracks are permanently sealed, resulting in a stronger chimney. Free brochure. **Golden Flue Systems**
548. Chimney Repair — Chimney contractor specializes in poured chimney linings. Also does chimney inspections and repairs, fireplace dampers and repairs, safety tests. Free brochure. **Homestead Chimney**
512. Top-Sealing Fireplace Damper — Damper installs on top of chimney; saves energy, stops drafts, eliminates chimney dampness. Easy to install and operate. Free brochure. **Lyemance International**
164. Chimney Liner — System seals, relines, and rebuilds chimneys from inside out with poured refractory. Works well for chimneys with bends and offsets. Free brochure. **National Supafu Systems**
90. Restoration Brick — Specialist in restoration, matching and blending of brick. Provider of over 10 million bricks for Thomas Jefferson's University of Virginia. Free literature. **Old Virginia Brick Co.**
206. Chimney Liner — Ventinox stainless-steel chimney-lining system installs without breaking through walls. Reduces creosote formation, increases heating efficiency, improves safety. Free brochure. **Protech**
461. Chimney Products — Supplier of refractory materials, cleaning products, gasket cements, chimney paint & water repellent. Free brochure. **Rutland Products**
320. ProSpec Architectural Cleaning Products — For terra cotta, masonry, & paint stripping. Proven on historic structures. Free brochure. **Watson Bowman Acme**
202. Stainless Steel Flue Liner — Stainless steel chimney liner is flexible and conforms to any twist and turn in the flue. Easy to install. Free brochure. **Z-Flex**

Division 5 — METALS/CORNICES

486. Cast Exterior Ornaments — Replications in a variety of materials (fiberglass, cast stone & concrete, cast aluminum). Free brochure. **Alpha-One Fiberglass Exterior**
147. Cast Architectural Elements — Specialist in design and production of columns, balustrades, pool coping, pavers, stairs treads, moldings, wallcaps, and mantels. Free brochure. **Architectural Facades Unlimited**
640. FRP Ornaments — Molded fiberglass replicas of exterior ornaments originally made in other materials. Projects include cornices, balconies, balustrades, and planters. Free literature. **Architectural Fiberglass Corp.**
643. Plaster & Molding Studio — Custom studio does preservation, restoration, and replication of ornamental plaster. Also exterior fiberglass cornices, architectural cast stone, sculpture. Free flyer. **Art Home Studios**
16. Custom Terra Cotta — Specialist in moldmaking & ram pressing, matching original pieces, restorations or new installations, duplicating color, texture, and detail. Free literature. **Boston Valley Terra Cotta**
582. Cupolas & Weathervanes — Aluminum cupolas, domes, weathervanes, cornices, ornamental load-bearing columns, and balustrades detailed for historic buildings. Rotproof. Baked-on finishes. Free flyer. **Cambellville Industries**
263. Weathervanes & Cupolas — Copper topped cupolas & weathervanes. Thousands of designs to choose from, or custom creations. Free brochure. **Crosswinds Gallery**
731. Fiberglass Church Products — Line of

fiberglass church products includes steeples, baptistries, light wall crosses, kinkglas windows, and baptistry heaters. Free catalog. **Fiberglass Specialties**
172. Weathervanes & Roof Elements — Offers unique handcrafted weathervanes, roof spires, lightning rods, and more. Free brochure. **Fischer Artworks**
121. Custom Casting & Lighting — Custom-cast architectural ornament in iron, aluminum, and bronze. Works from your specs, or will create designs for your approval. Free brochure. **Historical Arts & Casting**
441. Sheetmetal & Roofing Contractor — Experienced with landmark buildings. Specializes in slate & tile roofing, sheetmetal cornices & ornaments. Free brochure. **L.P. Kent Corp.**
459. Precast Architectural Products — In terra cotta, GFRG, FRG, cast stone & gypsum. Historic replication, on-site work, and pattern work from drawings. Free brochure. **David Kucera, Inc.**
873. Historic Markers & Castings — Many patterns and styles to choose from in cast aluminum and cast bronze. Also: Custom ornamental castings. Free literature. **Lake Shore Markers**
742. Roof Restoration & Sheetmetal — Installer & consultant for slate, tile, and metal roofing. Custom tile, copper roofing, and sheetmetal. Reasonable prices. Free literature. **Midland Engineering Co.**
929. Ornamental Sheet Metal — On-site restoration of metal building cornices; pressed metal ceilings. F inials, conductor heads, & other ornaments reproduced. Sheet metal roofing. Free brochure. **Hunt Miller Sheetmetal**
922. Architectural Materials — Company molds fiber glass reinforced polymers (FRP) for large-scale architectural elements that are strong, lightweight, maintenance free, and versatile. Free brochure. **Molded Fiber Glass**
279. Historic Molded Ornament — GFRG ornamental or architectural panels, including precise replicas of historic works, or new designs. Free brochure. **Molloy and Associates**
422. Architectural Ornament — Sculpture studio uses fiberglass-reinforced polymers to replicate cornices, terra cotta ornament, and other elements. Full custom services. Free brochure. **Rocca Noto Sculpture Studio**
659. Handcrafted Weathervanes — American handcrafted weathervanes; new and custom designs. Lectures, appraisals, & displays available. Free brochure. **Salt & Chestnut Weathervanes**
462. FRP Fabricator — Designs, engineers, and casts building components and architectural ornaments. On-site moldmaking. Free brochure. **Seal Reinforced Fiberglass**
65. Architectural Molding Materials — Molding compounds can be used on-site, and are readily pourable or brushable for painting onto vertical surfaces. Free brochure. **Smooth-On**
721. Fabricated Metal — Custom copper finials, weathervanes, roof ornaments, cornices, leader boxes, etc. Restoration of copper & slate roofs. Consultation; free literature. **Vulcan Supply**

Division 6 — WOOD & PLASTICS

222. Moldings & Millwork — Large selection of wood moldings and most turned products, including columns, pilasters, newels, and balusters. Free brochure. **A&B Wood Design**
747. Pre-Cast Gazebos — As well as arbors, pergolas, balustrades, pavers, wall caps, columns, planters, stair treads, and fountains. Free brochure. **A&M Victorian Decorations**
130. Wood Restoration — 2-part epoxy system restores rotted wood; saves historically significant and hard-to-duplicate pieces. Repairs can be sawn, drilled, sanded, and painted. Free brochure. **Abatron**
678. Interior Woodwork — Prime source for embossed moldings, stairs, casework, detailed cornices, chair rails, and paneling in fine hardwoods like walnut, oak, cherry, and mahogany. Free brochure. **American Custom Millwork**
14. Molded Ornament — Custom casting studio. Restores and replicates old ornaments or creates new patterns. Will make molds for those preferring own casting. Details. **Archicast**
897. Cast Ornament — Embellishments cast in FRG, modified gypsum, and GFRG. Fireplace surrounds, ceiling panels, balustrades, moldings, domes and more. Free brochure. **Architectural Products Mfg.**
726. Molding Materials — Glass-fiber-reinforced modified gypsum system for interior or exterior ornament. Simple to use; non-toxic; short mold cycles; lightweight. Free brochure. **Ball Consulting, Ltd.**
578. Wood Moldings — Catalog contains illustrations of over 150 decorative wood moldings and ornaments for every architectural and furniture need. Free copy. **Bendix Moldings**
317. Architectural Millwork — Major supplier of stock & custom millwork produces, a wide range of softwood & hardwood flooring, paneling, mantels, moldings, etc. Free catalog. **Boise Moulding & Lumber**
489. Custom Wood Moldings — Shortruns a specialty. Straight and curved/radial moldings in hardwoods and softwoods. Also casework, flooring & paneling. Free brochure. **T.J. Carr Co.**
680. Hardwood Moldings — Fine domestic & imported hardwoods & moldings: Straight, curved, composite. Millwork including entranceways, doors & windows, paneling, mantels, pilasters etc. Free brochure. **Center Lumber Co.**
158. Fiberglass Columns — Wide selection of architectural fiberglass columns. Ready to prime and paint, easy to install, maintenance free. Plain or fluted; interior or exterior. Free brochure. **Chadsworth Columns**
18. Classic Wood Columns — Full line of architectural wood columns & capitals in variety of sizes. Rotproof bases & aluminum plinths. Elements or complete column systems. Custom fabrication. **Chadsworth Columns**
880. Wood Moldings — High-end original and reproduction work, including curved, dentils & fluted styles, also mantels and rosettes. Free brochure. **Chesapeake Moulding & Millwork**
904. Architectural Ornaments — Corner brackets, moldings, turnings, carvings. Stock & custom Victorian gingerbread, finials, screen & entry doors, newels, balusters, columns, and more. Brochure. **Classic Architectural Specialties**
401. Architectural Elements — Source for hard-to-find moldings, railings, balusters, wainscoting, columns, custom millwork and turnings. Free brochure. **Condon Co.**
430. Molding Knives — Custom profile knives for woodworking machinery: Shapers, molders, molder/planers, and rosette tool holders. Free brochure. **Counselor Profiles**
992. Molded Architectural Ornament — Columns, capitals, cornices, and any other architectural embellishment can be custom-cast in FRP or GFRG. Line of stock columns and other elements. Free brochure. **DEC Associates**

420. Victorian Era Woodwork — In small or large runs, for interior, exterior & landscape applications. Free brochure. **J.A. Dawley Woodworking**
755. Architectural Millwork — Shop specializes in cabinetry, garden trellises & other types of exterior millwork. Free brochure. **Designs Craft, Inc.**
189. Molded Ornament — Wide range of interior and exterior molded ornament in both fibrous plaster and FRP. Custom work a specialty; has handled many large projects. Free brochure. **Edon Corp.**
616. Moldings and Millwork — Hardwood moldings, period and custom millwork, including paneling and stairs. Free brochure. **Empire Moulding @PRODLITBODY = 932. Classic Wood Entries** — Redwood entry pediments, exclusive moldings, mantels, paneling, pilasters, and other architectural millwork. Free flyer. **Executive Woodsmiths**
821. Columns & Turnings — Moldings, curved crowns, porch posts, capitals, carvings, fluting & spiral rope twist; other large turnings. Turned & stave-work columns. Free brochure. **Fagan Design & Fabrications**
471. Cast Ornament — In modified gypsum, FRP, FRG, GFRG, cast stone. Structural or non-structural work in a variety of finishes and colors. Free brochure. **Fiberglass Masters Technologies, Inc.**
490. Flexible Molding — Also rigid moldings, spot decorations, simulated wood carvings for furniture, etc. All styles & custom reproductions in polymers & polyesters. Free brochure. **Flex Moulding, Inc.**
98. Fabric Awnings — Fabricator of fabric awnings and related components to create traditional window awning look. Free literature. **Forster Corp.**
442. Hand-Carved Stone — Architectural and garden products such as statues, mantelpieces, fountains, wells, columns, gazebos, lampposts, etc. Free brochure. **Garden Ornaments Stone**
912. Architectural Columns — Columns are made of clear heart redwood for maximum durability. Patented Koll interlocking stave joint gives added strength. Available in diameters up to 48". Free brochure. **Hartmann Sanders Co.**
38. Architectural Columns — Manufacturers of high-quality architectural wood columns in wide range of stock and custom sizes. Also: Mantels, paneling, and millwork. Free literature. **Henderson, Black & Greene**
230. Moldings & Millwork — Wide selection of moldings, turnings, carvings, plinth blocks, and finials; company also offers complete millwork packages, including casework, paneling and stairs. Free brochure. **House of Moulding**
31. Custom Woodturnings — Manufactures stair balusters, newels, columns & ornamental capitals, corner blocks, rope/twisting, reeding, stock rails, fittings and more. Free literature. **Josef's Art Wood Turning**
5. Architectural Woodturnings — All types of custom spirals and turnings, hollow spirals, flutes, reeds, balusters, posts, circular moldings, custom hand rails and stairwork. Free brochure. **Mohamad Woodturning Corp.**
477. Moldings, Medallions & Niches — In high-density polyurethane & fire-retardant polystyrene. All styles. Free brochure. **NMC Decoration, Inc.**
474. Architectural Wood Products — Flooring, moldings, columns, staircases, mantels. Large stock inventory; custom millwork available. Free flyer. **National Hardwood Flooring & Moulding**
706. Architectural Millwork — In addition to traditional straight-run moldings, company offers a wide variety of elegant classically carved moldings. Free catalog. **Ornamental Mouldings**
493. Polymer Architectural Products — Columns, moldings, ceiling medallions, chair rails, and more. Free brochure. **Outwater Plastic Industries**
707. Wood Columns — Millwork based on designs from 1870 to 1920, in clear heart redwood, oak, mahogany. Balusters, newel posts, porch columns, railings, and custom turning. Catalog free. **Pagliacco Turning & Milling**
494. Suspended Wood Ceilings — System is available in 2 styles. Moldings and other architectural wood work in oak, cherry, and poplar. Free brochure. **Prime Wood Products**
495. Custom Moldings — Can match wood sample or drawing using the latest computer-controlled equipment. Premium-grade manufacturing standards. Free brochure. **R.I. Millwork**
161. Classical Wood Columns — Wood columns from 4" to 50" dia. up to 35 ft. long. Matching pilasters and 14 styles of capitals. Maintenance-free aluminum bases available. Custom work. Free catalog. **Schwerd Mfg.**
66. Wood Columns — Builds standard and custom columns up to 40-in. dia. and 40-ft. long. Tongue-and-groove stave joints; clear northern pine, clear heart redwood, and other woods. Free brochure. **Somerset Door & Column**
365. Period Interiors — Specialists in historic preser-

vation, restoration & reproduction. Design, fabrication, installation & finish work. Free brochure. **Strasser & Associates**
485. Architectural Millwork — In high-density polyurethane: Moldings, gable louvers, door systems, pilaster, mantels, and pediments. Free brochure. **Style-Mark, Inc.**
70. Aluminum Columns — Easy-to-install no-maintenance columns and strong corrosion-free railings. Standard styles, sizes; custom specifications welcome. Free brochure. **Superior Aluminum Products**
12. Cast Stone Ornament — Custom columns, cast stone and precast concrete. Contract design dept. and mold shop. Free brochure. **Techcrete Architectural Precast**
101. Architectural Repair Products — Manufacturers of interior and exterior building repair products. Exterior products repair and prime wood, patch and seal roofs, gutters, chimneys and more. Free brochure. **Tuff-Kote Co.**
15. Architectural Columns — Turning manufacturer specializing in columns, architectural columns, porch posts, spindles, stair parts, and decorative millwork. Free brochure. **Turncraft**
458. Custom Wood Doors — Custom millwork shop produces doors and other woodwork for high-end jobs. Free brochure. **Vermont Custom Doors & More**
232. Moldings & Millwork — Produces 80 stock molding profiles, 50 embossed moldings. Distributors for Challis stair parts, Coffman, L.J. Smith; and Marvin Windows and Doors. Free brochure. **White River Hardwoods**
498. W-S Molder/Planer — Cuts straight and circular moldings, casings, crowns, frames, and raised panels; jig allows elliptical cuts. Free brochure. **Williams and Hussey Machine Co.**
754. Wood & Polymer Moldings — Distributor of products from most major molding manufacturers. Custom reproduction moldings. Free brochures. **Wood-O-Rama**
163. Columns & Architectural Elements — Standard and custom wood columns, balustrades, polymer and plaster ornament, carved wood entries, garden furnishings, molded ornament, and more. Free brochure. **Worthington Group**

Division 7 — ROOFS

56. Snow Guards — Beautiful and practical: Cast-bronze eagle snow guards prevent avalanches of snow and ice from sliding off slate roofs. Other copper roofing specialties. Free brochure. **M.J. Mullane Co.**
286. Roofing Slate — As well as types for flooring, terraces & walkways available from these quarrier/producers. Color-matching services. Free brochure. **Rising & Nelson Slate Co.**
74. Ludowici Roof Tiles — Large supply of salvaged Ludowici tiles. Free information. **Tim Jeckering Architects**

Division 8 — DOORS & WINDOWS

69. Invisible Storm Windows — Match any window shape or color; removable storm windows available inside or outside mounted; screen and glass panels. Fixed, magnetic, sliding, or lift-out styles. Free brochure. **Allied Windows**
146. Wood Windows — Wood sash in any size and shape: Divided lite, round top, curved, double-hung, fixed, casement, or storm sash. Also: Shutters, screen doors, and trim. Free brochure. **Midwest Architectural Wood Products**
Specialty Wood Windows — Palladians, straight, and fan transoms. Single-, double-, or triple-glazed, thin muntins. Also: solid wood doors with insulating core. For pricing, call: (802) 722-9217. **Woodstone Co.**

Division 9 — VICTORIAN REVIVAL

424. Period Brass Hardware — For furniture and houses. Catalog sales only (\$5 catalog cost is refundable). Free brochure. **A Carolina Craftsman**
242. Faucets & Fixtures — Complete lines of modern, Victorian, & European plumbing. New things for claw-foot tubs, shower conversions in chrome or brass, high-tank toilets, pedestal sinks, and much more. Free catalog. **A-Ball Plumbing**
892. Tin Ceilings — 26 Victorian and Art Deco tin ceiling patterns. 2x8, 2x4 and 2x2 ft. panels for nail-up or lay-in. 13 cornices; pre-cut miters. 2x2 ft. center medallions. Free literature. **A.A. Abbingdon**
860. Carved Art Glass — Restoration, recreation, and installation of Victorian and Arts & Crafts style work. Free brochure. **A.N.T. Art**
402. Stained Glass Conservation — Services include: Condition Surveys, material specifications, project management, & execution of work. Free brochure. **ARS Stained Glass**

FREE PRODUCT INFORMATION

Use this form to get catalogs of historical products in this issue. (Literature is free to qualified professionals.) We'll forward your request to the respective manufacturers. **Allow 4-6 weeks for literature to arrive.**

THIS FORM EXPIRES OCTOBER 15, 1993

NAME _____
 COMPANY _____
 ADDRESS _____
 CITY _____ STATE _____ ZIP _____
 PHONE (____) _____

For free product information, FILL IN the appropriate numbers:

1 Your Business: Architect Contractor Interior Designer
 Engineer/Consultant Government Other (specify): _____

2 Is Your Need: Immediate Project? For Your Files?

PLEASE ENTER A 1-YEAR SUBSCRIPTION, AND BILL ME \$18.

Mail to: TRADITIONAL BUILDING, Product Literature Department
 69A Seventh Ave., Brooklyn, NY 11217 (718) 636-0788 Fax: (718) 636-0750

siegel's scratchboard

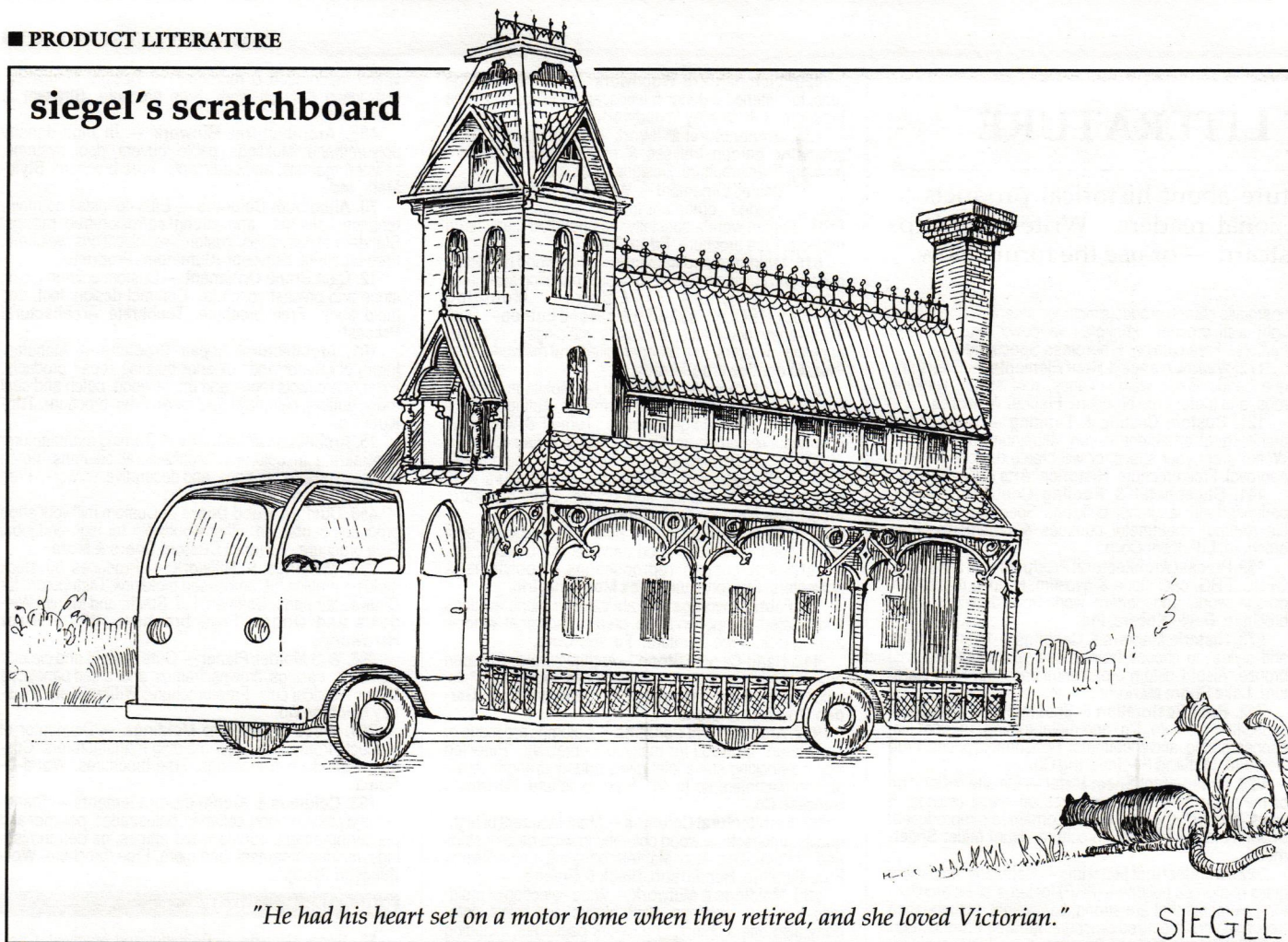

"He had his heart set on a motor home when they retired, and she loved Victorian."

468. Aluminum Sand Castings — Stock and custom products for landscape or architectural projects. Free brochure. **Alloy Casting Co.**

168. Octagonal Gazebo Kits — Victorian or western designs. Easy-to-assemble kits in 8 ft. to 20 ft. widths. Also, ornamental bridges. Free brochure. **AmishCountry Gazebos**

602. Victorian Gingerbread — Traditional wood architectural ornaments as well as newel posts, balusters, and finials. Free brochure. **Anthony Wood Products**

426. Antique Door Hardware — Also window products, lighting & mantels. Restoration services. Free brochure. **Antique Doorknob Co.**

425. Victorian Restoration Products — For the home: Lighting, plumbing, hardware, screen doors & molded ornaments. Free brochure. **Antique Hardware Store**

419. Ceramic Products — Historic reproduction and contemporary tiles, wash basins, wall sconces, estate numbers; hand-made. Free brochure. **Architectural Ceramics**

436. Authentic Reproduction Lighting — Art Deco and other turn-of-the-century lighting fixtures are cast directly from original fixtures. Antique fixtures also available. Free brochure. **Art Directions**

251. Custom Art Glass — Hand-beveled, stained, and etched glass windows, screens and tables for residential and commercial installations. Free literature. **Art Glass of the South**

766. Historic Lighting — Vast selection of highest quality lighting reproductions, from 18th through early 20th century: Residential, commercial, institutional. Standard designs & custom. Free catalog. **Ball & Ball**

293. Authentic Restoration Hardware — Largest selection of authentic 18th and 19th century hardware: Hinges, latches, pulls, shutter hardware, much more. Also: custom work and repairs. Free mini-catalog. **Ball & Ball**

767. Metal Grilles — Radiator covers custom made to your measurements. Drop-in grilles, flat grilles, grilles with borders, convector grille covers, & more. Free brochure. **Barker Metalcraft**

586. Bathroom Fixtures & Hardware — Turn-of-the-century bathroom fixtures & accessories; reproduction & antique. Classic brass hardware and hard-to-find parts. Free brochure. **Bathroom Machineries**

411. Custom Shutters — Exterior or interior; paneled or louvered. Using original 19th century machinery, can duplicate any shutter. Antique shutter hardware. Free brochure. **Beech River Mill Co.**

351. Art On Ceramic Tile — Baroque to post-modern styles, for baths, kitchens, fireplaces, floors, & exteriors. On tiles or ceramic fixtures. Free brochure. **Belfor Design, Ltd.**

73. Window & Door Hardware — Manufacturer & distributor of current & obsolete hardware for doors, windows, closets & patio doors and much more. Free catalog. **Blaine Window Hardware**

257. Murals & Faux Finishes — Marbleizing, wood graining, & glazing of furniture, walls, floors, columns. Mural work. Free brochure. **Bopas**

488. Letter Boxes & Poles — Cast aluminum in period or custom designs. Free brochure. **Bose Associates**

162. Decorative Door Hardware — Unique designs for European-style iron knockers, latches etc. Free brochure. **Bouvet, Inc.**

13. Victorian Roomset Wallpaper — Vast array of borders, fills, and patterns. Catalog shows 7 roomsets including: Neo-Grec; Anglo-Japanese; Morris; Aesthetic Movement. One chapter sent free. **Bradbury & Bradbury**

622. Victorian Lighting — High-quality brass reproductions of chandeliers and sconces from the Victorian era. Free brochure. **Brass Reproduction**

605. Custom Stained Glass — Etched, stained and leaded glass, and restoration for commercial, religious, and residential projects. Free brochure. **Brown's Stained Glass Studio**

693. Victorian Carpet & Lace — Real Victorian Carpet is woven on 19th-century machinery, using original designs. Hundreds of authentic patterns available. English lace for window treatments. Free brochure. **J.R. Burrows & Co.**

200. Picket & Board Fences — Also, PVC lattice. Wide variety of styles. Custom work available. Free brochure. **Burton Woodworks**

126. Wood Doors & Windows — Specialist in repair and recreation of doors and windows and other millwork for historic buildings; restored windows in the Smithsonian Institution. Free flyer. **Cassidy Co.**

Historic Wallpapers & Tiles — Georgian/Federal, Victorian, Edwardian, Arts & Crafts, and Art Deco wallpapers; reproduction Victorian and Edwardian wall tiles. Call (604) 592-4916. **Charles Rupert Designs**

965. Wood Entries — Furniture builders create "furnishings for your entry" — entry door systems built like fine furniture. Free brochure. **Chautauqua Doors**

19. Tin Ceilings — 18 patterns of tin ceilings for Victorian homes and commercial interiors. Designs from Victorian to Art Deco. Several exclusive patterns; cornices in 4-ft. lengths. Free brochure. **Chelsea Decora-**

tive Metal Co.

75. Push-Button Switches & Dimmers — Push-button light switches in quality reproductions. Switch plates in plain brass or ornamented. Also push-button dimmers. Free brochure. **Classic Accents**

597. Victorian Lighting — Authentic, handcrafted, solid-brass Victorian and Early 20th century lighting including Art Deco, and Craftsman collection. Gas and electric chandeliers, sconces, lamps. Free brochure. **Classic Illumination**

429. Period Lighting — Victorian and Colonial street lights, sconces, luminaires, and lighted bollards. Free brochure. **Classic Lamp Posts**

610. Historic Block Printed Wallpaper — Wallpaper printed from 18th & 19th century antique wood blocks; many other historically accurate documentary papers. Free brochure. **Classic Revivals**

62. Ceiling Fixtures — Solid brass ceiling fixture with hemispherical frosted glass globe looks like period Art Deco light. Also: polished chrome. Custom metalwork and repairs. Free brochure. **Conant Custom Brass**

960. Wood Screen Doors — Available in many styles & any size. Choices of woods includes pine, douglas fir, oak, & mahogany, stained or painted. Free brochure. **Coppa Woodworking**

315. Copper Coatings & Patinas — 4 finish colors, including verdigris green, can be applied to copper or any metal. Also apply to any interior or exterior material, including wood. Free brochure. **Copper Coatings & Patinas**

131. Victorian Millwork — 19th century designs in solid oak and poplar: fretwork, brackets, corbels, grilles, turnings, and gingerbread. Also: Molded polymer architectural elements. Free catalog. **Cumberland Woodcraft**

316. Architectural Glass Services — Large studio offers design, fabrication, installation, project development, and conservation/restoration services for commercial, civic, and religious projects. Free brochure. **Cummings Studios**

910. Architectural Stone — Skilled carvers provide stone services including statuary, ornament, mantels, entrances, and architectural moldings. Reproductions in marble, limestone or bronze. Free brochure. **DMS Studios**

Molded Ornament — Huge selection of molded ornament in plaster and compo. Wide variety of traditional and historical styles. Call (312) 847-6300 for info on obtaining catalog. **Decorators Supply Corp.**

730. Cupolas & Weathervanes — Redwood cupolas with hand-seamed copper roofs; standard and custom. Large selection of antique-inspired or custom weathervanes, finials and caps. Free brochure. **Denninger Products**

25. Historic Tiles — For fireplaces, kitchens, or bath: Coordinated borders and patterns in any size. Victorian, Neoclassic, De Morgan, Art Nouveau, Arts & Crafts, more. Period pavers. Colorful catalog. **Designs In Tile**

577. Carved Wood Elements — Architectural accoutrements, including mantels, sculpted in solid woods. Your designs executed or select from large array of stock elements. Free brochure. **Raymond Enkebol**

431. Antique Hardware — Supplies original curtain tie-backs, door knockers & door hardware, furniture hardware & twist bells. Free brochure. **Eugenia's Place**

238. Decorative Plaster — Specialized plaster finishes such as sgraffito, fresco, and scagliola; molded ornament, mold-making and models; restoration and preservation services. Free literature. **Ewing Restoration**

469. Faux Finishing Products — Manufacturer/supplier of designer and architectural finishes. Also offers classes. Free brochure. **Faux Effects**

449. Faux Finishing Workshops — Marbleizing, graining, glazing, and other specialty paint finishes taught to professionals in hands-on workshops. Free brochure. **Fe Fi Faux**

289. Molded Ornament — Fine period & custom ornament: Cornices, medallions, sculpture, niches, capitals, brackets, domes. 2,300 antique molds available. Routinely handles large jobs. Free catalog. **Felber Ornamental Plastering**

196. Plaster Ornament — Hundreds of ornaments in fiber-reinforced plaster from turn-of-the-century molds. Also: Custom duplication of ornament from your sample. Free flyer. **Fischer & Jirouch Co.**

439. Gazebos & Garden Ornaments — Statuary, fountains, furniture & accessories in metal and stone. Free brochure. **Florentine Craftsmen**

753. Molded Ornament — Plaster, cast stone and concrete architectural elements: Cornices, fireplaces, columns, ceilings domes and much more. Free brochure. **Girolami & Co.**

478. Custom Spiral Stairs — Spiral and curved stairs are custom-built to your specifications. Available in welded steel or solid wood. Free brochure. **Goddard Mfg. Co.**

28. Stained & Leaded Glass — Designer and manufacturer of leaded and stained glass windows, lampshades, architectural pieces, etc. Custom work; museum-quality restorations. Free brochure. **Golden**

Age Glassworks.

966. Victorian Porch Swings — Line of Victorian porch furniture includes swings, gliders, and picnic tables. Custom furniture available. Free brochure. **Green Enterprises**

652. Hardware & Bathroom Fixtures — Sinks: Pedestal, drop-in, old and new styles. Clawfoot tub sets and accessories. Faucets for tub and shower; period hardware. Much more. Free flyer. **Hardware Plus**

948. Door Hardware — Whitehall door hardware is a coordinated suite, including wardrobe & cabinet knobs with matching switch and push plates. Free brochure. **Hinges & Handles**

914. Parquet Floors — Classic hardwood parquet borders and full-room patterns are exact reproductions of floors found in homes built from 1880 to 1920. Free brochure. **Historic Floors of Oshkosh**

85. Historic Shutters — Specialist in handcrafted interior & exterior shutters. Complete restoration of any wooden shutter or windows available. Free literature. **Historic Shutter & Restoration**

94. Interior Shutters — Interior shutters in 8 styles manufactured to your window sizes. Raised & recessed panels (no louvers) in wide range of hardwoods. Custom work handled. Free brochure. **Historic Windows**

243. Period Plumbing Fixtures — Reproduction pedestal basins, kitchen and bath faucets, and more. Free brochure. **J.T. International**

470. Historically Accurate Lighting — Original designs for residential, commercial, and civic buildings. Also offers restoration services. Free brochure. **Jefferson Art Lighting Co.**

472. Lithophanes — Porcelain transparencies of Victorian images for night lights, lamps, sun catchers, chandeliers, oil lamps & sconces. Free brochure. **Jefferson Art Studio**

568. Victorian Tile — Authentic Victorian tile for fireplace surrounds and hearths, in both encaustic and lithographed patterns. Free brochure. **H&R Johnson**

799. Shutters — Shutters made in both moveable louver and raised-panel styles. Authentic pegged mortise & tenon joinery. Both custom and traditional designs. Free brochure. **Kestrel Mfg.**

Crystal Chandeliers — Huge collection of chandeliers, sconces, & candelabra assembled from imported & domestic parts designed & maintained by the company. Brass & crystal. Call (919) 623-6188. **King's Chandelier Co.**

775. Shutter Hardware — Reproductions in cast & wrought iron. Shutter dogs, hinges, & slide bolts. Mountings for frame, stone, brick & stucco homes. Large collection of house hardware. Free brochure. **Knobs 'n Knockers**

275. Antique Reproduction Lampshades — 96 styles ranging from \$35 — \$95. Give period feel to any interior. Free brochure. **Lampshades of Antique**

473. Wheel-Cut Art Glass — Custom wheel-cut glass for residential and commercial interiors. Free brochure. **Lehmann Studios**

584. Custom Hardware — Custom historic hardware for domestic and commercial applications. Has wide range of antique patterns that can be adapted, or will work to your sample. Free brochure. **Brian F. Leo Custom Hardware**

813. Antique Plumbing — Supplies over 1,200 plumbing products such as tub shower enclosures, high & low tank toilets, sinks, light fixtures, hardware, garden decorations, and more. Free brochure. **Mac the Antique Plumber**

460. Carved Woodwork — Moldings, doors, frames, mantels and other interior architectural elements; furniture. Free brochure. **Macartney Classical Woodcarving**

35. Victorian Woodwork — 19th-century millwork in redwood and select hardwoods. Ornamental shingles, turnings, ornamental trim, moldings, screen doors, brackets, balusters, railings, and more. Catalog. **Mad River Woodworks**

760. Door & Window Hardware — Exclusive importer of a wide range of traditional house hardware; over 21,000 items available. Free brochure. **Maguire Iron**

491. Restoration Hardware — Special emphasis on window hardware. Can lost-wax cast unique items. Free brochure. **Milford Replacement Hardware**

326. Antique Wood Paneling & Flooring — Antique pine & southern yellow pine in widths up to 24 in. Also, oak & chestnut up to 20 in. Beams, doors & other salvaged materials. Free brochure. **North Fields Restorations**

618. Traditional Lighting — Reproduction Victorian lighting. Also American and European antique lighting fixtures. Repair and restoration services. Free brochure. **Nowell's Lighting**

492. Victorian Gingerbread — Exterior trim and furniture, all from durable cypress treated with water sealant. Free brochure. **O'Connor Cypress Woodworks**

780. Victorian Storm-Screen Doors — Large selection of hand-crafted wooden doors in all sizes. Also: brackets, spandrels, running trim, corbels, gable decorations, railing, & gates. Free flyer. **The Old Wagon Factory**

479. Marquet & Inlaid Wood Floors — Using native and exotic 3/4 in. hardwoods. Free brochure. **Thomas D.**

Osborn Mosaic Hardwood Floors

124. Shutter Hardware — Specialist in Shutter hinges, shutter dogs (holdbacks), shutter bolts and shutter ring pulls. Free literature. **Peters & Son**

480. Plaster Architectural Products — For restoration or new construction. Medallions niches, moldings, mantels and more. Free brochure. **Plaster Cast Designs**

636. Moldmaking & Casting Materials — Rubbers for flexible molds — brush-on or pourable. Fast durable molds for plaster, cements, and resins. Variety of casting resins. **Polytek Development**

989. Antique Doors & Architectural Elements — 40,000 sq. ft. showroom holds a vast array of antique doors, furnishings, and architectural elements. Free brochure. **Red Baron's**

793. Stained Glass Studio — Major studio designs and fabricates art glass panels for residential and commercial buildings. Skilled in restoration and conservation of stained glass domes. Free brochure. **Reflection Studios**

581. Brass & Iron Registers — Beautiful solid brass and cast-iron registers are made from 19th & early 20th century originals. Free catalog. **Reggio Register Co.**

509. Woodcarvings — Original and reproduction designs. Designs are digitized for accuracy in copies. Work is finished with hand tools. Free brochure. **Ron Wiener, Woodcarver**

43. Vintage Lighting — Victorian and turn-of-century chandeliers and sconces: Gas, oil, and electric. Antique and reproduction fixtures; replacement parts and glass shades. Free catalog. **Roy Electric**

288. Gold Leaf Supplies — Gold leaf in booklets or rolls, oil sizes, Kolner burnishing clays for water gilding, imitation gold & aluminum leaves & rolls. Free brochure. **Sepp Leaf Products**

514. Classes On Gold Leafing — Hands-on workshops on architectural gilding, water gilding, oil gilding, glass gilding, antiquing, toning, compo casting, and more. Free flyer. **Center for the Gilding Arts**

44. Exterior Shutters — White pine plantation shutters with moveable louvers. Also fixed louvers and 3 styles of raised-panel shutters. Unfinished or painted in your color choice. Hundreds of sizes. Free brochure. **Shuttercraft**

455. Gingerbread & Other Sawed Work — Gable trims, fan brackets, appliques, running trim, sawn balusters, scrolls, etc. Also, folk art whirligigs and miniature houses. Free brochure. **Silver Creek Mill**

463. Victorian Antique Furniture — Large selection of American Victorian era as well as other periods. Free brochure. **Southampton Antiques**

853. Restoration Millwork — Custom moldings, windows & doors, Victorian etched glass panels, casework, stairwork, & wainscoting. Free brochure. **Spoon River Millwork**

47. Cast-Iron Staircases — The Kensington revives tradition of using cast iron for straight porch steps. Modular components; bolt-together assembly. Also circular stairs. Complete catalog. **Step toes & Wife**

294. Victorian Showerhead — Features 169 holes on an 8 in. dia. face. Shower-arm bracket available or installs with 1/2 in. standard fittings. Free brochure. **Sunflower Shower Co.**

464. Period Bathroom Fixtures — Slipper tubs, oak tank toilets, water closets with fittings. Also, chandeliers. **Sunrise Specialty Co.**

725. Mold-Making Products — Polymers for mold-making in pourable, sprayable, paintable, and trowelable consistencies. Also, lightweight urethane casting resin. Free brochure. **Synair Corp.**

523. Fireplace Doors — Filigree-trimmed glass fireplace doors: Cabinet & folding styles for flat and arched-top models. Mesh curtain screens; custom shapes & sizes. Free brochure. **Thermo-Rite Mfg.**

42. Documentary Papers & Fabrics — Collection of fabrics and wallpapers is based on originals found in America's great historic houses. Through interior designers and fine shops. Color brochure. **Richard E. Thibaut**

784. Victorian Screen Doors — Authentic Victorian screen-storm doors in a wide range of styles & sizes. Custom work. Free brochure. **Touchstone Woodworks**

575. Brass Carpet Rods — European-style solid brass stair rods and finials at affordable prices. Hand-polished, lacquered; easy to install mountings. Free brochure. **Unique Designs Mfg.**

525. Victorian Wallpaper — Owner and reproducer of the Brillion collection, which contains over 4,500 rolls of 1,377 patterns of American documentary wallpaper, c.1850. Free brochure. **Victorian Collectibles, Ltd.**

465. Victorian Lighting — Solid brass reproduction lighting fixtures. Over 50 authentic designs. Free brochure. **Victorian Lightcrafters, Ltd.**

373. Victorian Lighting Fixtures — Authentic reproduction Victorian & turn-of-century electric and gas chandeliers and wall brackets. Variety of glass shades. Catalog free. **Victorian Lighting Works**

710. Gazebos — Line of elegantly designed and carefully crafted gazebos lend a note of 19th-century graciousness to any landscape design. Engineered to meet all building codes. Free brochure. **Vixen Hill Gazebos**

123. Cedar Shutters — Shutters are crafted from clear old growth western red cedar. Joints are mortise-and-tenon with teak locking pins. 5 traditional styles in standard and custom sizes. Free brochure. **Vixen Hill Shutters**

52. Sheet Metal Ceilings & Ornament — Richly ornamented metal ceilings, from original turn-of-the-century dies. Also: Exterior cornices and hundreds of sheet metal ornaments. Free catalog. **W.F. Norman**

466. New & Antique Lighting — Restoration and reproduction fixtures in brass. Also Dietz Pioneer Kerosene street lamps. Free brochure. **Washington House of Reproductions**

Compo Ornament — Vast collection of traditional compo elements can be combined in endless variations to embellish walls, ceilings, woodwork, and furniture. For catalog, call (818) 841-5700. **J.P. Weaver Co.**

712. Victorian Millwork — Screen doors, porch parts, custom woodwork, moldings, ornamental trim and gingerbread of all types fabricated from original period patterns. Free catalog. **Wood Factory**

467. Fabrics & Wallcoverings — Line-for-line reproductions for historic houses, preservation societies & museums. Free brochure. **Zina Studios**

■ Division 10 — SPECIALTIES

37. Pigeon Control — Get rid of bird pests with inconspicuous stainless steel needles that eliminate roosts — without harming building. Humane and practical. Free flyer. **Nixalite**

■ Division 16 — ELECTRICAL

511. Designer Lighting — Halogen metal floor lamps and wall sconces with Murano glass and scavo finish. Free brochure. **Gabriel Mediterraneo**

874. Ornamental Castings — Stock and custom ornamental castings in cast aluminum, brass and bronze. Also ornamental cast street lighting fixtures. Free brochure. **Leitelt Brothers**

604. Reproduction Lighting — Colonial reproduction light fixtures in copper, brass, tin, and iron. Post lanterns, wall lanterns, chandeliers, and candlestands. Custom work. Free brochure. **Lighting by Hammerworks**

454. Arts & Crafts Shop, Lighting & Newsletter — Source for Roycroft furniture, papers, & china; articles on sources for period fixtures & furnishings; period restoration design consulting service. Free brochure. **Roycroft Associates**

WE HAVE THE PRESCRIPTION FOR YOUR RENOVATION ILLS

- General Store Items
- Tin Ceilings
- Cabinet Hardware
- Lighting
- Push Button Switches
- Window Hardware
- Sinks & Faucets
- Clawfoot Tubs
- Old Kitchen Stoves
- Bath Accesories
- Builders Brass
- Bar Rail
- Weathervanes
- Toilets
- Mirrors
- Showerheads
- High Tank Toilets
- Cotton Shower Curtains
- Door Knockers
- Door Hardware
- Rim Locks
- Mail Boxes
- Pocket Door Pulls
- Dead Bolts
- Cast Iron Hinges
- Shutter Hardware
- Hoosier Hardware
- Door Stops
- Wrought Iron
- Pot Racks
- Glass Shades
- Switch Plates
- Floor Registers
- Cherry Pitters
- Apple Peelers
- Much, Much More...



5' Clawfoot Tub Sale
\$699⁰⁰ *

* Call for details/while supplies last!

The Largest Selection of Old Style Hardware in the World! Thousands of New Items!

**Call for FREE Store Catalog
1-800-422-9982**

Or Order our new Custom Items Catalogs for \$7.00 (refundable with first order). Money Back Guarantee!

The **Antique Hardware Store**

9730 Easton Road, Route 611 • Kintnersville, PA 18930

WRITE IN NO. 425

America's Highest Quality Reproduction Historic Hardware & Lighting

Specify the hardware and fixtures that are used in the finest restorations in North America.

MADE IN THE U.S.A — Unlike much "traditional" hardware being sold today, Ball & Ball hardware is American-made. Nearly 100% of the items sold by Ball & Ball are made by the 40 experienced craftsmen in our own shop. (The few items made by other manufacturers are carefully noted.) Our exacting standards are the highest in the industry for historical accuracy, quality of materials, and workmanship.

OUR FAMILY NAME'S AT STAKE — Three generations of the Ball family are actively involved in the company. It's *our name* stamped on the metal — so we make sure everything is done at the highest quality level.

COPIES & REPAIRS — We can repair or copy almost any hardware item. Send sample or detailed working drawing for a quotation. All packages will be acknowledged, and requested work will be quoted in advance.

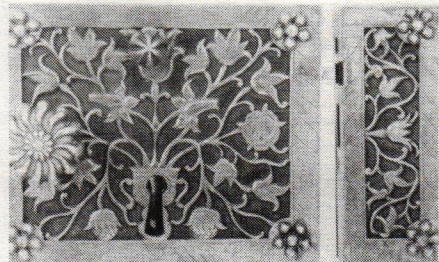

SHOWROOM & MUSEUM — The Museum adjacent to our manufacturing facility in Exton, Pa., contains an extensive collection of original antique hardware gathered over the last 50 years. It's quite an education in itself and, if requested, any item in our Museum Collection can be duplicated. Museum is open 8:00-4:30 weekdays.

OUR GUARANTEE — Stated simply, we expect our products to work — stock items as well as custom work and repairs. If they don't, return them, and "we'll make it right." We won't charge for anything that has not been forced beyond reasonable limits. (We reserve the right to charge for repair or replacement costs for items damaged through no fault of ours.)

HINGES

Ball & Ball offers the most extensive selection of historic reproduction hinges — from hand-forged iron strap hinges of the 1700's, to cast iron and bronze hinges of the 1800's, to early 20th-century models — such as an Art Deco 1910 Cast Brass Hinge ①. This lift-off hinge (3-1/4" x 2-1/2" wide open) is an exact copy of an original, which has the finials as an integral part of the hinge joint. Available right-hand or left-hand.

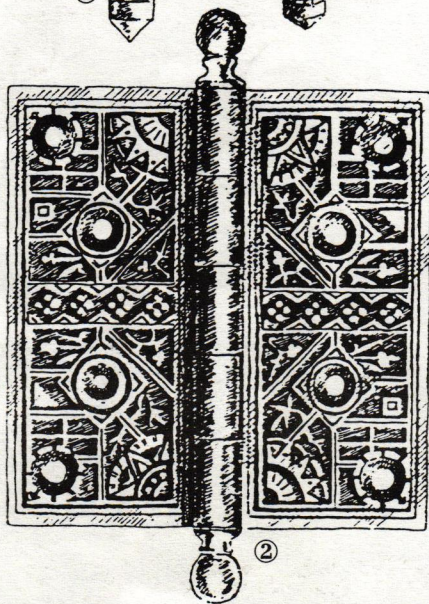
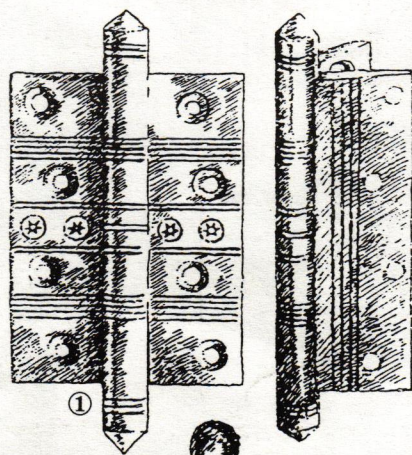

The V53 Victorian Decorative Cast Hinge ② comes in brass or bronze. It's a loose-pin design with threaded finials, cast directly from a fine original, and measures 4-1/2" x 4-1/2".

LOCKS

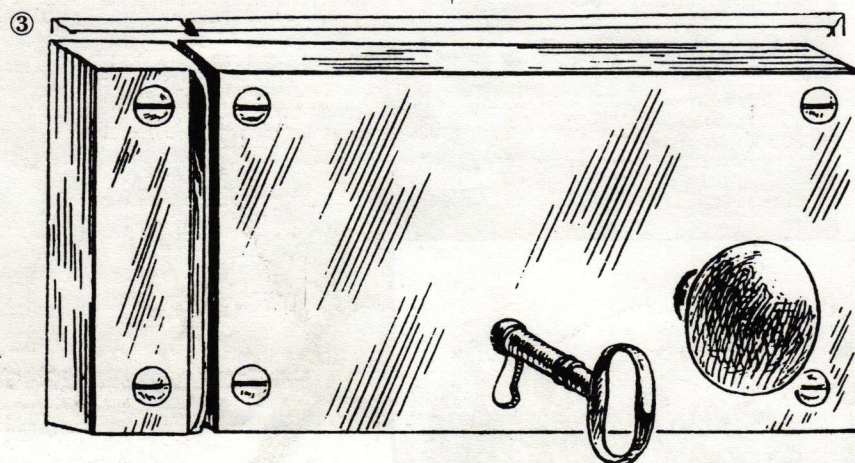

Ball & Ball makes a wide line of authentic door locks from the 18th and 19th centuries. Our X90 box locks ③ combine modern convenience with authentic charm. Faithful to the historic originals, this lock has a brass box covering an iron plate on which the operating mechanism is mounted. They're appropriate for meticulous historic restorations as well as new residences.

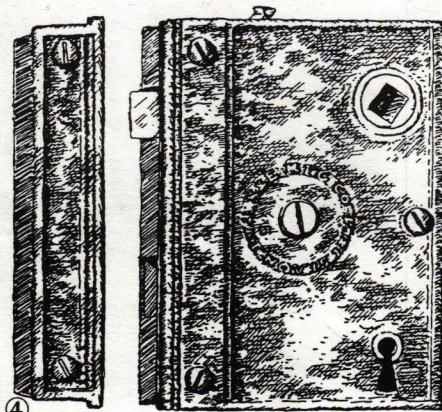

The V6 Cast Iron Vertical Lock ④ is a precise copy of one of the most widely used locks of the 1840-1870 period. Overall size: 3-1/4" wide, 4-1/2" high. Can be furnished with appropriate ceramic knobs in white or Bennington Brown.

LATCHES

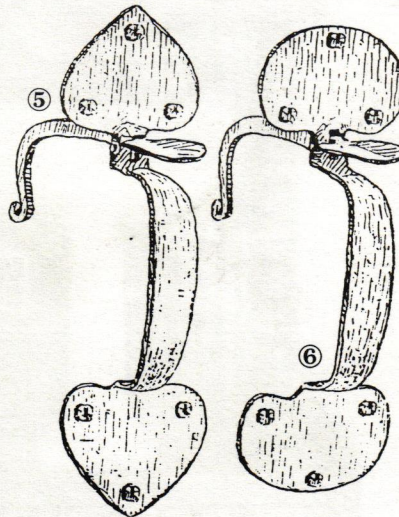

We have a varied stock of authentic hand-forged reproduction thumb latches, ranging from Colonial up to the 1850's. Many special thumb latch shapes can be made at the STOCK PRICE. ⑤ 10-1/2" hand forged spade-end latch. ⑥: 9-3/4" semi-handmade bean-end latch.

LIGHTING

Ball & Ball offers the finest reproduction lighting fixtures, from Colonial through the early 20th Century. All brass is solid — not plated — and glass used is hand-blown lead crystal. Pure copper, tin, and iron are used for fixtures that require these metals.

The 18th-century Dana House pumpkin-shaped lamp ⑦ is from Woodstock, VT. Hall lighting fixture ⑧ was made in the early 20th century for the U.S. Capitol. Made of cast brass, spun brass, and fluted brass

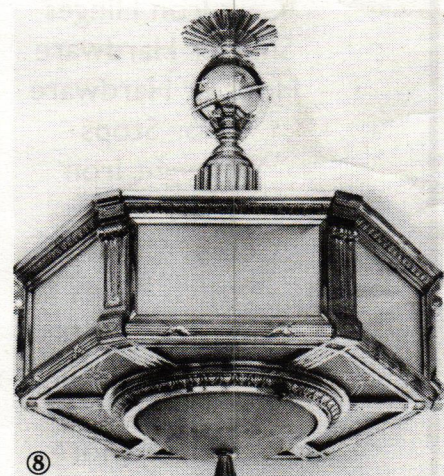

tubing, it features etched glass on all 6 sides and bottom — and measures 19" across.

Send For Our Catalog

THE FREE MINI-CATALOG

— For an introduction to the complete Ball & Ball line, write, call or FAX to get our free Mini-Catalog. Or you can write in No. 293 on the Reader Service Card.

You can also write for our new Catalog of Lighting Fixtures from the 18th, 19th, and 20th Century. Or write in No. 766 on the Reader Service Card.

THE BIG 108-pg. CATALOG

— Our lavishly illustrated full Catalog not only shows hundreds of our hardware and lighting products, but also provides many tips that will help you spot quality differences in reproduction hardware. Send \$5 for the full Catalog. Even our 108-pg. Catalog can't show every one of our 2,000 standard products. So if you're looking for something rare or unusual, call or FAX us.



463 W. Lincoln Highway

Exton, PA 19341

Phone: 215-363-7330

Fax: 215-363-7639

Orders: 1-800-257-3711

WRITE IN NO. 293 FOR HARDWARE MINICATALOG & 766 FOR LIGHTING