

# ARCHITECTURAL RECORD





## THE TRADE MARK THAT COMES TO LIFE...

... to serve you with products that aid in obtaining, more economically, the qualities you want in concrete.

Our half century of experience is promptly available for:

1. product-selection consultation
2. product-use service on the job . . . through the 43 branch offices shown here staffed by more than 100 Master Builders skilled fieldmen.

If you are associated with concrete in any way, you will benefit by calling in one of these men.

**THE MASTER BUILDERS COMPANY**  
*Division of American-Marietta Company*

CLEVELAND 3, OHIO • TORONTO 9, ONTARIO

POZZOLITH • MASTERPLATE • EMBECO and other products  
 for the improvement of concrete and mortar.

# ARCHITECTURAL RECORD

March 1957 Vol. 121 No. 3

Copyright 1957 by F. W. Dodge Corporation, with all rights reserved. ARCHITECTURAL RECORD (combined with AMERICAN ARCHITECT and ARCHITECTURE) is published monthly, except May 1957 when semi-monthly, by F. W. Dodge Corporation, 10 Ferry Street, Concord, New Hampshire. Editorial and executive offices: 119 West 40th Street, New York 18, New York. Western editorial office, 2877 Shasta Road, Berkeley 8, California.

## STAFF OF ARCHITECTURAL RECORD



**H. Judd Payne**, Publishing Director; **Robert F. Marshall**, General Manager; **John Knox Shear**, A.I.A., Editor-in-Chief; **Marshall T. Ginn**, Circulation Manager; **Emerson Goble**, Managing Editor; **Frank G. Lopez**, A.I.A., Senior Editor; **James S. Hornbeck**, A.I.A., Senior Associate Editor; **Elisabeth Kendall Thompson**, Senior Associate Editor and Western Section Editor (Berkeley, California, Office); **Robert E. Fischer**, Associate Editor (Engineering); **Florence A. van Wyck**, Associate Editor; **Jeanne M. Davern**, Associate Editor (News); **Herbert L. Smith, Jr.**, A.I.A., Associate Editor; **Ernest Mickel**, Dan Street (Washington), **John Caulfield Smith**, M.R.A.I.C. (Canada), Contributing Editors; **Grace M. Anderson**, Assistant Editor; **Margaret R. Fuerst**, Assistant Editor (Engineering Assistant); **Helen E. Cook**, Editorial Assistant (Production); **Dianne Thomas**, Editorial Assistant; **Eugene H. Hawley**, Design Director; **Thomas L. McArthur**, **Mary Ann Godfrey**, Design; **Sigman-Ward**, Drafting Consultant; **Thomas S. Holden**, Industry Relations Consultant; **Clyde Shute**, Statistical Consultant; **George Cline Smith**, Economics Consultant; **Clifford Dunnells, Jr.**, Field Research Consultant; **Daniel J. Howe, Jr.**, Public Relations Consultant.

## TABLE OF CONTENTS

### The Record Reports

Perspectives	9
Buildings in the News	10
Temple University Builds: Master Plan for 100 Years	16
Architecture Abroad: Venezuela Builds "Teleferico"; Air Force Builds Housing in Spain	16B
Meetings and Miscellany	21
House Built on Research. Bogotá Training Project	28
A Washington Report. BRI Grows Up to a Big Job. <i>By Ernest Mickel</i>	32
News from Canada. <i>By John Caulfield Smith</i>	36
Washington Topics. <i>By Ernest Mickel</i>	40
Construction Cost Index	58
Required Reading	62
Reviewing the Record	362
Calendar and Office Notes	368
Current Trends in Construction	430

### Architecture, Atoms and a Peaceful World 181

A series of articles prepared with Members of the Committee on Nuclear Facilities, American Institute of Architects, to stimulate architectural imagination in a new and challenging field.

For An Architecture of Nuclear Buildings. An article *by Elisabeth Kendall Thompson* 182

Heavy Ion Accelerator Building, University of California Radiation Laboratory, Berkeley, Calif.; Corlett and Spackman, Architects 183

The Design of Particle Accelerator Buildings. An article *by William Maxwell Rice, A.I.A. and Elisabeth Kendall Thompson* 186

### Inter-American Housing Center

Bogotá, Colombia; Staff of the Center, Architects 193

### Lockhart, Texas

An article *by Colin Rowe and John Hejduk* 201

### Two Connecticut Houses

1. House for Mr. and Mrs. Bernhard Stern, Danbury, Conn.; Herbert Beckhard, Architect 207

2. House for Mr. and Mrs. George Goldberg, Stamford, Conn.; Huson Jackson, Architect 210

### Eagle Rock Clubhouse

Los Angeles, Calif.; Richard J. Neutra, Architect 213

### A Much Discussed Theater Design

New City Theater, Münster, Germany; Harald Deilmann, M.-Cl. von Hausen, Ortwin Rave, Werner Ruhnau, Architects 217



Cover: Chase Manhattan Bank, New York City; Skidmore, Owings & Merrill, Architects; © Ezra Stoller photo

# ARCHITECTURAL RECORD

Continued from page 5

<b>One Hundred Years of Significant Building</b>	
10. Institutions	223
<b>Building Types Study Number 244 — Office Buildings</b>	
A Review of the New Skyscraper. <i>By James S. Hornbeck</i>	227
The House of Seagram, New York City; Mies van der Rohe and Philip Johnson, Architects	230
Time and Life Building, New York City; Harrison & Abramovitz, Architects	232
Astor Plaza Building, New York City; Carson & Lundin, Architects	233
3325 Wilshire Building, Los Angeles, Calif.; Victor Gruen Assoc., Architects	234
Capitol Records Tower, Hollywood, Calif.; Welton Becket & Assoc., Architects	235
Borg-Warner Building, Chicago, Ill.; A. Epstein & Sons, Architects and Engineers	236
666 Fifth Avenue Building, New York City; Carson & Lundin, Architects	237
Socony-Mobil Building, New York City; Harrison & Abramovitz, Architects	238
Inland Steel Building, Chicago, Ill.; Skidmore, Owings & Merrill, Architects	239
Corning "Tower of Glass", New York City; Harrison & Abramovitz & Abbe, Architects	240
Illuminating Building, Cleveland, Ohio; Carson & Lundin, Architects	241
Ford Office Building, Dearborn, Mich.; Skidmore, Owings & Merrill, Architects	242
The H. C. Beck Building, Shreveport, La.; Neild-Somdal-Assoc., Architects	243
33 West 51st Street Building, New York City; Harrison & Abramovitz, Architects	244
Southland Life Building, Dallas, Texas; Welton Becket & Assoc., Architects	245
711 Third Avenue Building, New York City; William Lescaze, Architect	246
Pittsburgh State Office Building, Pittsburgh, Pa.; Altenhof and Brown, Architects	247
Chase Manhattan Bank, New York City; Skidmore, Owings & Merrill, Architects	249
Proposed Mile High Illinois, Chicago, Ill.; Frank Lloyd Wright, Architect	250
<b>Architectural Engineering</b>	
A New Wrinkle in Stressed-Skin; aluminum panels pleated for strength — and an exciting pattern	251
Sound Systems. Article 1 — Fundamentals of equipment operation and selection. <i>By J. F. McParland, Jr.</i>	255
Product Reports	260
Time-Saver Standards. Sound Systems — 1, 2 & 3	263
Roundup	274
Literature	340
<b>Index to Advertising</b>	432

## OFFICERS OF THE F. W. DODGE CORPORATION

James McV. Breed, *Chairman of the Board*; Paul Abbot and Thomas S. Holden, *Vice Chairmen of the Board*; Howard Barringer, *President*; Irving W. Hadsell, Chauncey L. Williams, *Executive Vice Presidents*; Howard M. Thompson, *Vice President and Treasurer*; Julius T. Little, Robert F. Marshall, T. Oliver Morgan, O. O. Paulsell, H. Judd Payne, George Cline Smith, *Vice Presidents*; Carl S. Bennett, Clinton C. Bennett, Ralph M. Hairston, Roy J. Hard, Arthur D. Prior, Richard H. Ray, John M. Williams, *Regional Vice Presidents*; Edwin H. Freed, *Assistant Vice President and Comptroller*; Walter F. DeSaix, Clifford G. Dunnells, Jr., Gault Eastman, Clyde Shute, Marc Wayne, *Assistant Vice Presidents*; Sanford D. Stockton, Jr., *Secretary*; William C. Breed, Jr., George W. Morgan, Jr., *Assistant Secretaries*; Irving B. Satin, *Assistant Treasurer*.

## OTHER F. W. DODGE SERVICES

Dodge Reports — Dodge Statistical Research Services — Sweet's Catalog Services — Dodge Books — Dodge Mailing Service — The Modern Hospital — The Nation's Schools — College and University Business — Hospital Purchasing File — Chicago Construction News — Daily Pacific Builder — Denver Daily Journal — Real Estate Record & Builders Guide.

Members of Audit Bureau of Circulations and Associated Business Publications. ARCHITECTURAL RECORD is indexed in Art Index, Industrial Arts Index and Engineering Index.

Every effort will be made to return material submitted for possible publication (if accompanied by stamped, addressed envelope), but the editors and the corporation will not be responsible for loss or damage.

Subscription prices: Published monthly except May 1957 when semimonthly. U. S., U. S. Possessions and Canada: \$5.50 per year; other Western Hemisphere countries, Spain, to those who by title are architects and engineers, \$9.00 per year. Single copy price except Mid-May 1957 issue \$2.00; Mid-May 1957 issue \$2.95. Beyond Western Hemisphere, excluding Spain, to those who by title are architects and engineers, \$9.00 per year for 12 monthly issues not including Mid-May 1957 issue. Subscriptions from all others outside U. S., U. S. Possessions and Canada for 12 monthly issues, not including Mid-May issue, \$24.00 per year. Change of address: subscribers are requested to furnish both old and new addresses, sending if possible stencil impression from magazine wrapper; allow four weeks for change.



## P E R S P E C T I V E S

**LITTLE GOLIATH:** The SMALLEST chapter of the American Institute of Architects is in TEXAS, according to the listing in the A.I.A. 1956-57 *Membership List*.

**DEMOCRACY:** Among eight "Phoenix men" welcomed as "newly registered architects" in a recent issue of the Central Arizona A.I.A. *Monthly Bulletin* was Frank Lloyd Wright (whom the State of Arizona suddenly noticed last year was *not* on its architectural registration list).

**THE LADIES, BLESS 'EM:** An anonymous letterwriter in the January issue of *Redbook*, responding to an earlier article on "How to Avoid Outgrowing Your Home," had a forthright prescription of her own — "The problem in a nutshell is simply this: male builders are stupid. They are busy in their offices drawing up blueprints, while we housewives have to make do with the homes they think we want. What we need is more women architects."

**GOLDEN TOWERS AND BALLAD SINGERS:** You can't get away from news of aluminum these days. There's Kaiser with its very own geodesic dome out in Hawaii (pages 251-254). There's Reynolds with its \$25,000 annual architectural award, and its two-volume work "Aluminum in Architecture." There's Alcoa with its new product development program that includes an annual home design conference to be inaugurated this year (April 11-13) under the chairmanship of Pietro Belluschi, and its traveling "exhibit" starring ballad singer Josh Wheeler and a Broadway cast to point up the contributions of aluminum-clad insulation to economical home heating and cooling. Then there's just the simple fact that aluminum isn't necessarily gray any more, but that's about like trying to convince yourself that snow isn't necessarily white. Probably the most romantic result so far is the idea of "gold" aluminum, which will be used in a skyscraper for the first time on the 34-story tower projected for

575 Lexington Avenue in New York by Sam Minskoff and Sons, Inc., builders (Sylvan and Robert Bien, architects). At the press luncheon where details of this project were announced, Reynolds had its "sales manager for monumental construction," A. H. Williams, to answer the technical questions, and he provided a rather provocative sidelight on another project of another material. In response to a query on whether the anodizing process could match the color of the Seagram's building now going up at 375 Park in — as everybody knows by now — bronze, Mr. Williams asserted that it not only could but had, for the benefit of the Seagram's building committee. To the remark of "a certain young lady" on the committee that "it won't turn green with age, though, will it?" Mr. Williams acknowledged (with obvious pride) that "we are pleased to say it would not!" While Mr. Williams' point was, of course, the durability of the finish, it is an interesting footnote that green is one of the few colors the anodizing process has not yet been able to produce to Reynolds' satisfaction: they can do charreusse, but — so far — no green.

**THE CONSTRUCTION OUTLOOK** as revealed in F. W. Dodge's Corporation's monthly tallies of construction contracts awarded will have a new look this year whatever the construction trends may be. Statistical coverage of construction indicators is being expanded to include the 11 western states as well as "the 37 states east of the Rockies" long covered by analysis of Dodge Reports. (Details on page 430.) To get the 1957 picture still farther in advance, the source is, of course, "Brakes and Accelerators," the latest edition of the annual Dodge preview of future construction potentials (AR, Nov. 1956). The 1956 preview turned out to be right on the nose: not only on the estimated increase in construction contracts (three per cent) but on the pattern of the changes: an increase in nonresidential building, plus an even greater increase in heavy engineering activity,

partly offset by a moderate decline in housing.

**NO DECLINE IN HOUSING**, by the way, was expected in the Dodge preview for 1957. The estimate was for a small increase in new nonfarm dwelling units (from an estimated 1,100,000 in 1956 to an estimated 1,125,000 in 1957), no change in floor area, and a six per cent increase in total dollar volume. In the midst of the current hue and cry among home builders about the money crisis, it is also interesting to note that while FHA- and VA-financed mortgages declined in January, conventionally-financed mortgages for residential construction actually showed an increase (details on page 430), following a trend established in 1956.

**AUTOMATION IN 1790:** It keeps being repeated that there's nothing new about "automation" except the current excitement about it, but who can cite an 18th century example of an "automatic factory?" — Square D. Company, manufacturers of electrical control equipment of the kind used to actuate automatic manufacturing operations, came on one some time ago in the course of some research in the automation field. It seems that in 1790 one Oliver Evans opened a completely automatic flour mill on the banks of a little creek near Philadelphia. The mill, powered by a water wheel, could turn out 300 bushels of flour an hour from grain fed to a bucket conveyor and then moved, entirely by water power, through a numerous succession of belts, screw conveyors, and coarse and finish grinding operations.

**DESIGN IN CONTINUITY**, the concept of designer Frederick Kiesler of the "endless house" schemes, has found expression in a newly-opened New York art gallery — World House (in the Carlyle Hotel, Madison Avenue and Seventy-seventh Street). The interiors, whose walls "flow" into the ceiling and whose stairs "float" above their cantilevers, were done in association with architect Armand Bartos.

## THE RECORD REPORTS BUILDINGS IN THE NEWS

### HHFA STUDIES NEW YORK'S LINCOLN SQUARE PROPOSAL

Plans for the nation's most ambitious urban redevelopment scheme, New York's proposed Lincoln Center for the Performing Arts, have been filed with the Housing and Home Finance Agency by the Mayor's Committee on Slum Clearance (Robert Moses, chairman), along with an application for a Federal grant under Title I of the housing act. Under the proposal, the Federal government would contribute \$33,470,075 and the city \$16,735,038 to acquisition of the site; private redevelopers are expected to spend \$178,206,000 for a total project cost of \$228,411,113.

The scheme for the 80-acre site (plan at right) has been developed by an international committee of consulting architects working with architects Harrison and Abramovitz of New York. The group includes Sven Markelius of Sweden, Alvar Aalto of Finland, Marcel Breuer, Philip Johnson and Henry Shepley of the United States.

The new home of the Metropolitan Opera (seating 3800), the New York Philharmonic's Concert Hall (2800), the Repertory Theater (1000) and the Theater for ballet (2200) all face the central plaza. Juilliard School of Music, with a curriculum broadened to include drama, will occupy the education area.

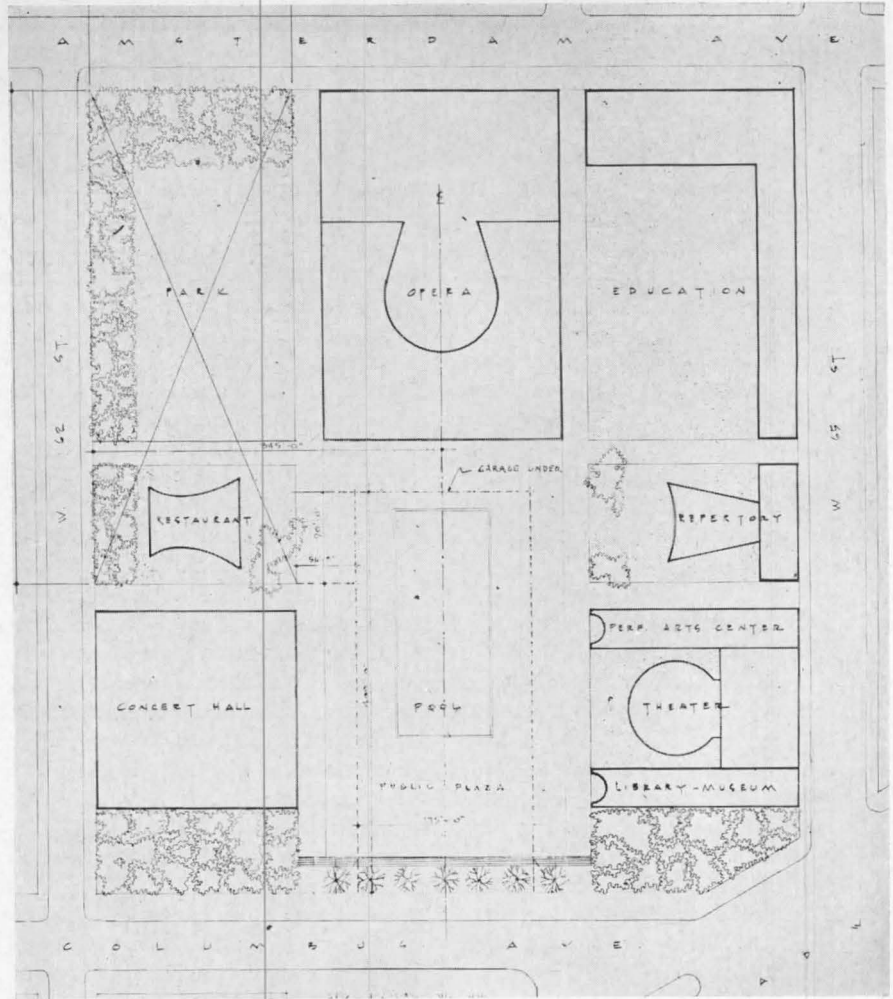

### PRUDENTIAL GIVES BOSTON ITS BIG BACK BAY CENTER

A multi-million-dollar business, civic and residential center to be financed largely by Prudential will be built on a 31-acre site in Boston's Back Bay district under plans for "The Prudential Center" announced January 31 by the Prudential Insurance Company of America. Hoyle, Doran and Berry of Boston (successors to Cram & Ferguson) are the architects, Metcalf & Eddy of Boston the engineers, and Pereira & Luckman of Los Angeles and New York the coordinating architects.

The site — more than twice the size of Rockefeller Center — is comprised of 28 acres now the Back Bay Yards of the Boston and Albany Railroad, on which Prudential acquired the option held by New York realtor Roger Stevens (for whom the "Boston Center Architects" developed a now-defunct scheme four years ago — AR, Oct. 1953, facing page 142) and another two and a half acres in adjoining parcels. Site cost is estimated to exceed \$5 million.

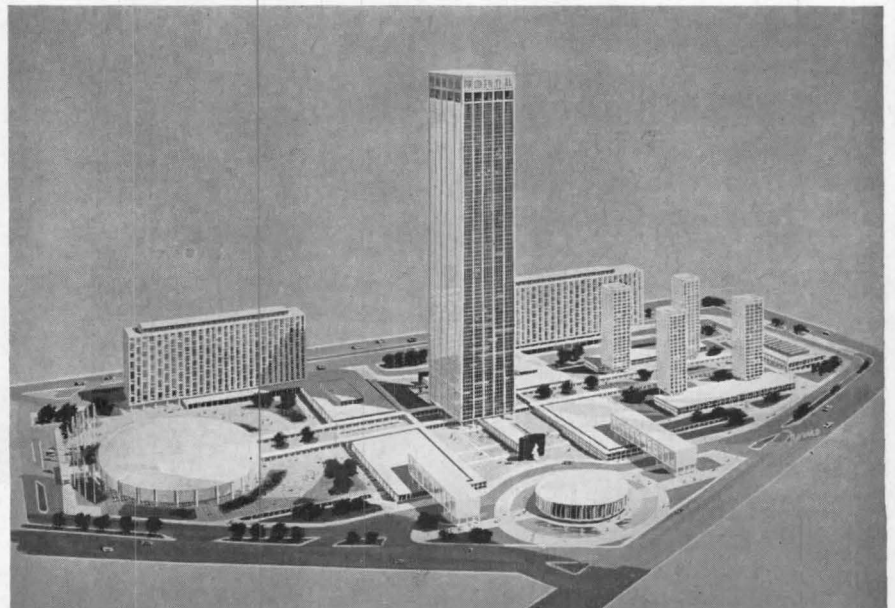

50-story \$50 million tower, Prudential Northeastern regional home office, will be surrounded by (right) 1250 apartments in four towers and long structure behind them; (left rear) proposed 1000-room hotel to be built by "private interests"; (left foreground) civic auditorium to be erected by City of Boston; (center foreground) circular restaurant flanked by store and office buildings. Glass-walled covered walkways connect the buildings

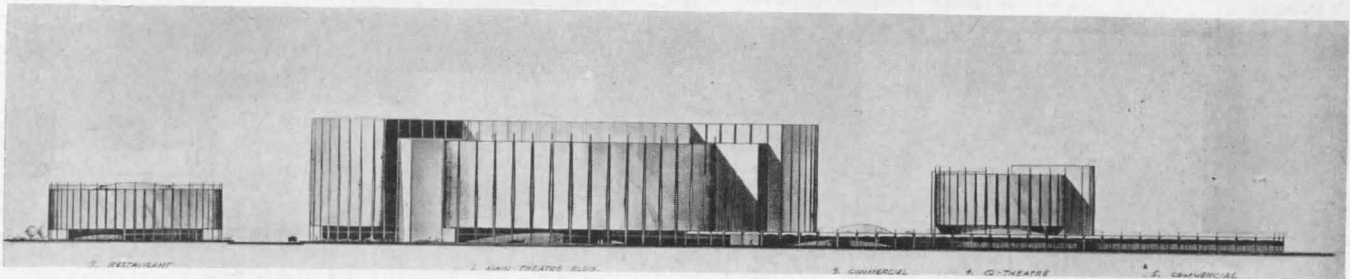

## ROGER STEVENS PROMOTES DREAM THEATERS FOR LINCOLN SQUARE

Neighbor to the north of the Lincoln Center for the Performing Arts (across-page) will be — if Roger Stevens' dreams come true — this complex of six theaters plus restaurants and commercial facilities designed for an investment group Mr. Stevens heads by the architectural firm of Pereira and Luckman to embody theatrical concepts of the noted scene designer Jo Mielziner. Overall cost of the project is estimated at \$35 million. Both for performers and playgoers, the plans would offer not only a new

experience in theatrical techniques but a new high in amenities.

Five of the theaters would be under one roof in a seven-level scheme that puts orchestras on the third level, with balconies, bars and lounges, and private club facilities on four levels above, and central lobby, with display area, bar and lounge and performers' dressing rooms on the level below, leaving the street level free for rentable commercial space, except for central ticketing facilities to serve all five theaters.

A new design for the stage developed by Mr. Mielziner, combined with his determination to hold the maximum house depth to 80 ft for optimum visual and acoustical conditions and the need to attain an economic seating capacity, produced the fan-shaped plan of the theaters: a scheme which by extending the stage apron onto the orchestra floor and widening the area between the theater's side walls has achieved both a larger usable playing area and a larger seating capacity without increasing the depth of the orchestra floor.

Once the fan shape of the individual theaters was established, the circular concept for the five-theater complex became almost inevitable — and a complex that would let theaters share complicated and expensive service facilities was wanted both for economy and for operating efficiency. A key element in the scheme evolved is the central turntable truck lift for moving sets from basement garage to the stage of any of the five theaters; this not only greatly reduces handling time but expense, by eliminating any street-handling — trucks will drive down ramps right into the garage and onto the turntable — and thus obviating the need for one of the three crews normally required.

The sixth theater, known as the "Q" theater, was developed separately as an even more advanced and experimental concept — it will, for one thing, eliminate scenery and expect the most advanced lighting techniques to do the whole job of creating scenic effects.

(More news on page 12)

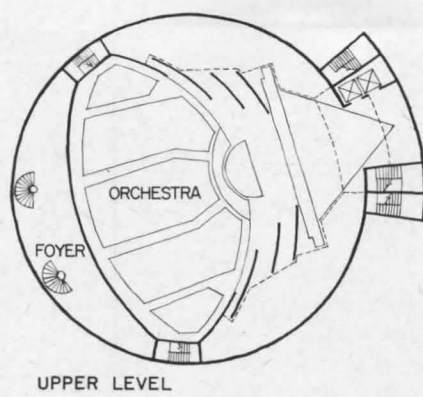
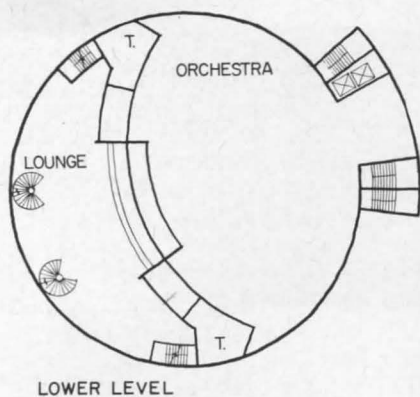
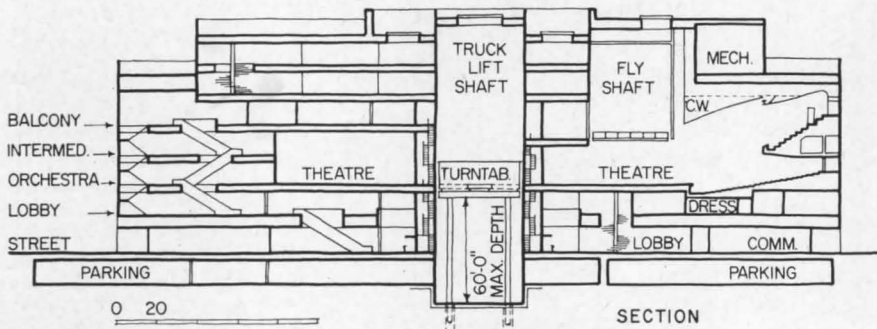
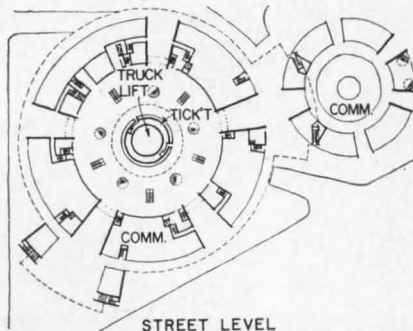
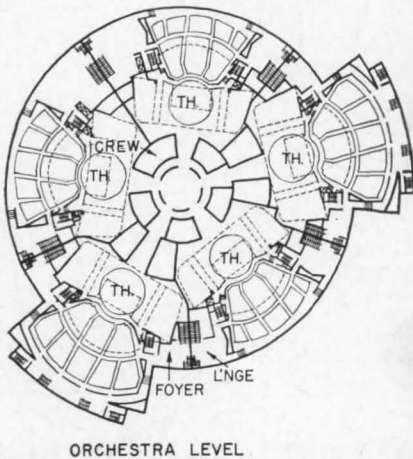
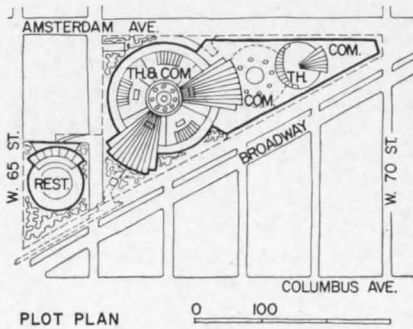

# THE RECORD REPORTS

## BUILDINGS IN THE NEWS

(Continued from page 11)

### PROPOSALS SUBMITTED FOR NATIONAL CULTURAL CENTER

Plans for a \$36 million national civic auditorium and cultural center on one of three proposed Washington, D. C., sites ranging in size from 18 to 27 acres were under discussion last month following submission to the President of the recommendations of the 21-member District of Columbia Auditorium Commission created by Congress in July 1955 to formulate plans for the design, location, financing and construction of the center.

The proposals, contained in a 95-page report illustrated with renderings and plan studies, were developed with the aid of a Technical Planning Board which included seven architectural firms and Stanford Research Institute. Pereira & Luckman acted as coordinators of the Planning Board. Other members are: Faulkner, Kingsbury & Stenhouse, Washington, D. C.; Giffels & Vallet Inc., L. Rossetti, Detroit; Holabird & Root & Burgee, Chicago; MacKie & Kamrath, Houston; Reynolds, Smith & Hills, Jacksonville; Shepley, Bulfinch, Richardson & Abbott, Boston. All served without compensation.

Major construction costs of the Center would be raised by private subscription, according to the Commission's recommendations, but it is hoped that the Congress will supply the site. Revenues from rentals, concessions and parking estimated at some \$487,000 annually, are expected to cover operating expenses.

(More news on page 16)

**SITE PLAN STUDIES** of the three "suitable site locations" recommended by the Auditorium Commission: 1. Foggy Bottom — South, on a rise above the Potomac and closest of the three to hotels and the capital's population center, was preferred by the Commission; the A.I.A. also endorsed it. 2. Southwest Redevelopment Area — East Site. 3. Southwest Redevelopment Area — West Site. The first two sites are approximately 27 acres; No. 3 is about 18 acres. 4. Rendering described as "overall" aerial view of proposed facilities

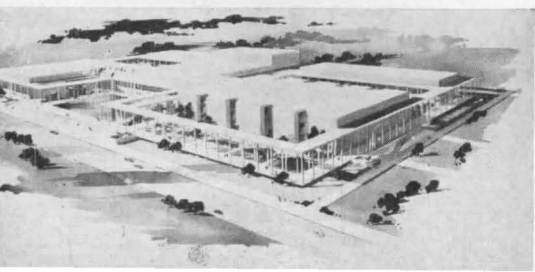
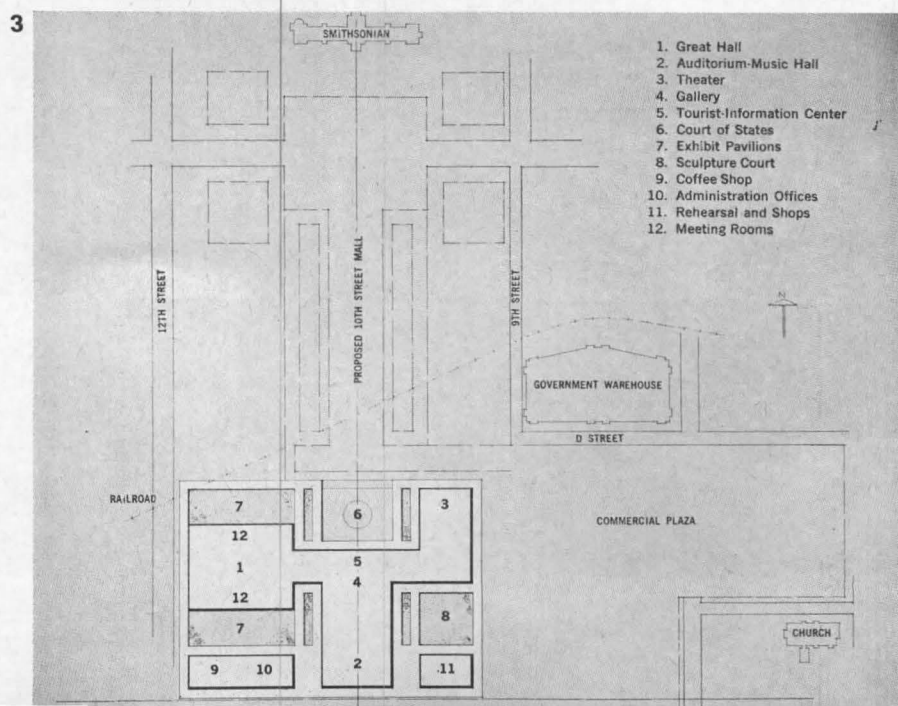
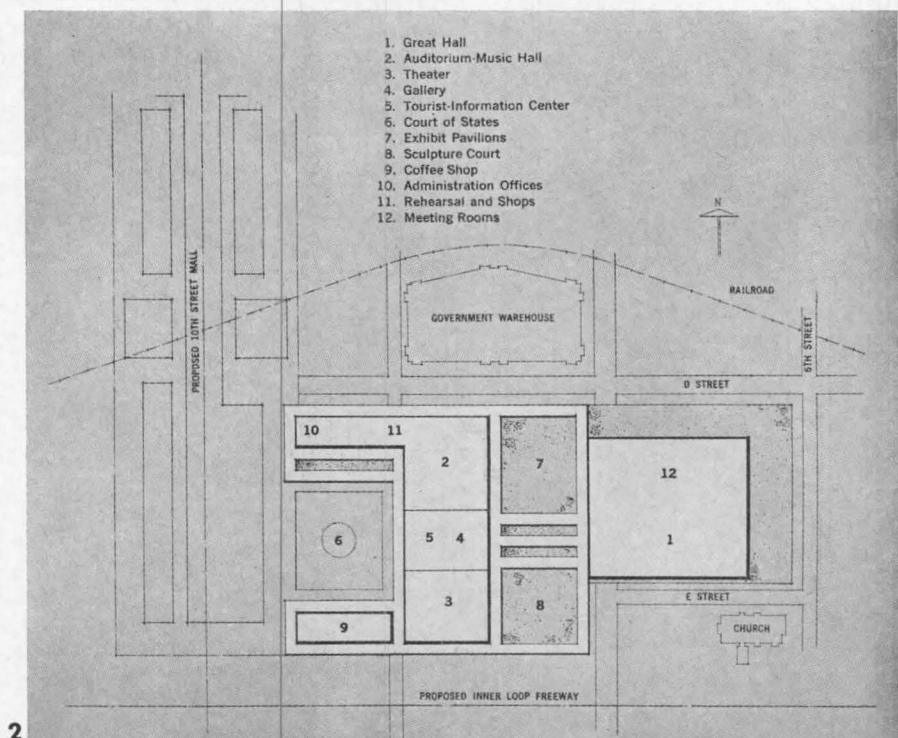
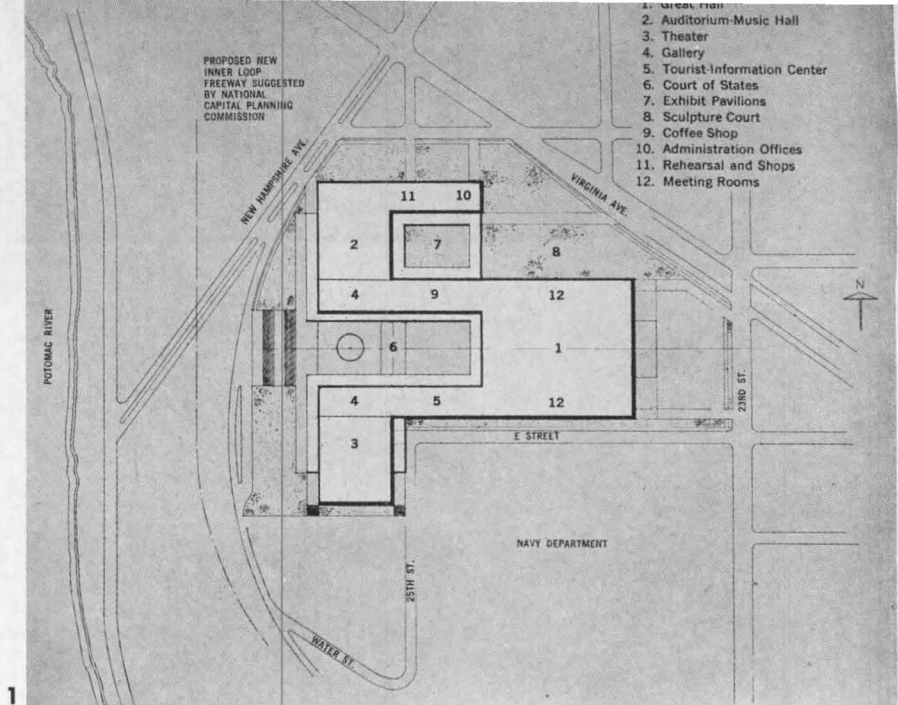



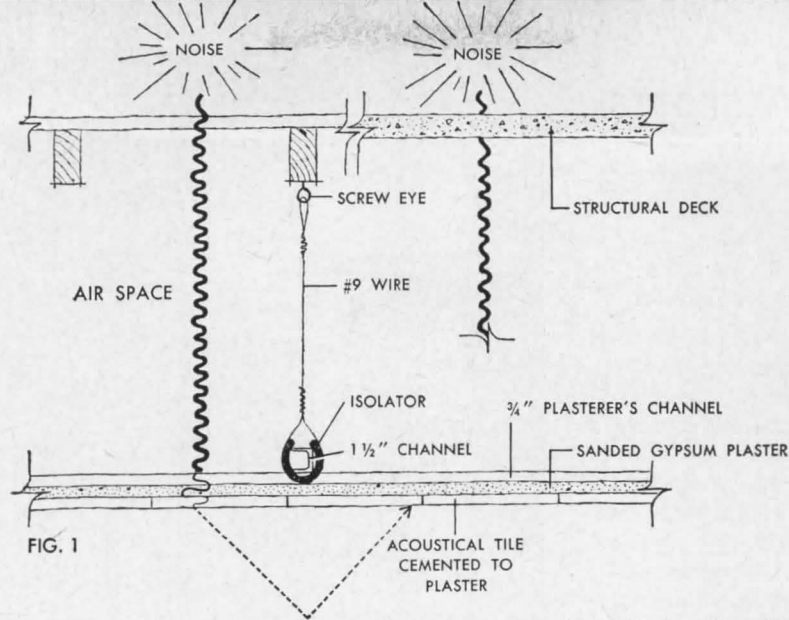

A suspended ceiling of metal lath and sanded gypsum plaster can be dropped by wire to provide mass, an air space, and an airtight barrier to minimize the flow of sound. An isolator can also be wrapped over the metal supporting channel. The acoustical material provides the sound absorption required in the room below.

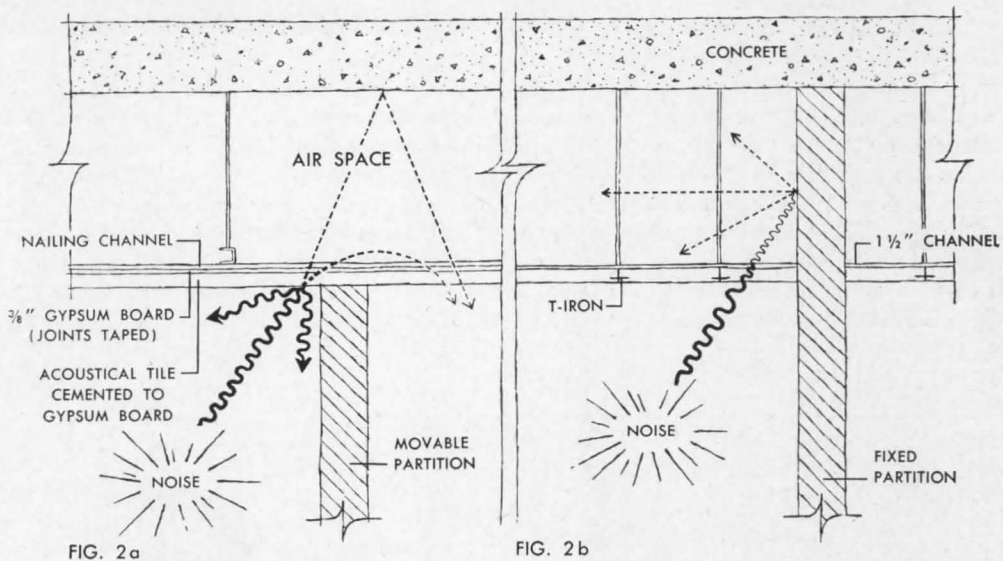

A membrane of  $\frac{3}{8}$ " gypsum board should be installed behind acoustical tile for added mass, unless partitioning is joined to structural ceiling.

# sound transmission problems

sion loss (Fig. 2a). Three-eighth-inch gypsum board with all edges taped is highly efficient. This construction has adequate mass and an airtight membrane that help reduce the flow of sound through the ceiling.

When the partition is extended through the acoustical ceiling to the underside of the slab above, the acoustical ceiling requires no special backing (Fig. 2b). The wall acts as an effective barrier to the transmission of sound.

In both types of construction, acoustical materials reduce the intensity of sound before and after transmission.

For details on how Armstrong acoustical materials can help you solve sound transmission and other noise problems, see your Armstrong Acoustical Con-

tractor. An expert in his field, he is familiar with all types of sound conditioning and can recommend a material to satisfy every job need.

For free booklet, "Armstrong Acoustical Materials," filled with data on the latest sound-conditioning methods and materials, write Armstrong Cork Company, 4203 Rock Street, Lancaster, Pennsylvania.

## Armstrong

### ACOUSTICAL CEILINGS

Cushiontone® • Travertone\* • Arrestone®  
Minatone® • Corkoustic® • Crestone®

\*TRADE-MARK

(Continued from page 12)

## TEMPLE UNIVERSITY BUILDS: MASTER PLAN FOR 100 YEARS

A really long-range approach to its expansion problems is taken by Temple University of Philadelphia, where immediate building requirements are being considered in the context of a master plan for the next 100 years as developed by Nolen and Swinburne, architects.

The plan is conceived in three phases: first, buildings immediately needed; second, buildings known to be required in the future; third, buildings required in the future "whose need cannot now even be imagined."

The first phase, for which Nolen and Swinburne have completed preliminary design of the buildings (see model photo), will add a total of 650,800 sq ft to the university's building area in a science group consisting of chemistry, physics and biology buildings and a "special facilities" group consisting of a School of Business, a Teachers College and a Communications Center. In the second phase, the university will add another 655,000 sq ft in a student union addition, physical education building, men's

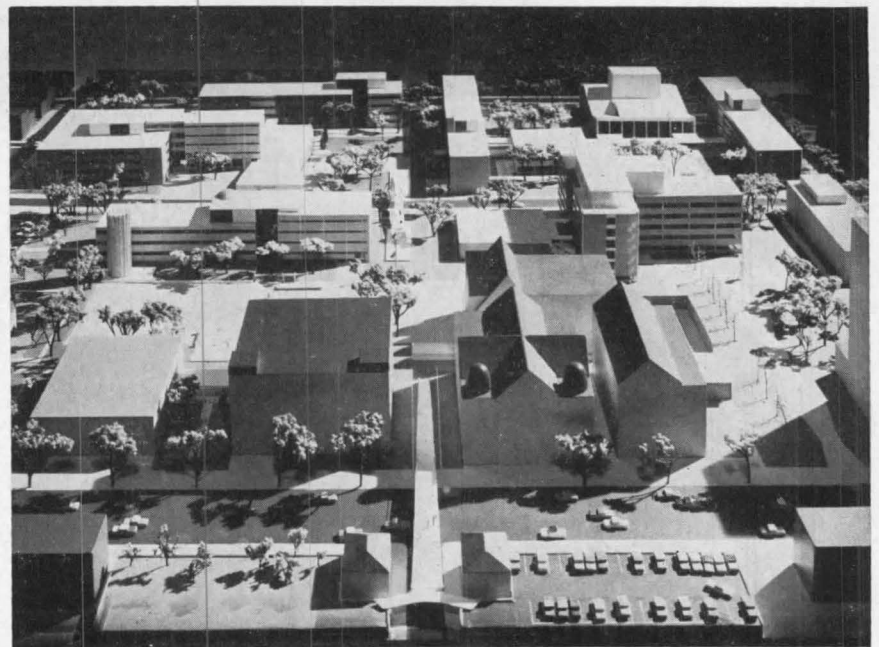

Courtland V. D. Hubbard

dormitory, library addition, law school, additional classrooms, women's dormitory addition and power plant addition. For Phase III purposes, the master plan reserves 12 acres of ground.

In plan, Temple is now, as the architects put it, "compressed into a ribbon along Broad Street, . . . bounded by noise on the west and south; by city

blight on the east and north." The master plan provides for expansion over an additional 16 acres of ground, blighted areas and streets eliminated. Open areas and courts within the campus (as in photo here) are studied as carefully as the buildings in the effort to create an environment which will have "a feeling for people and the quality of human scale."

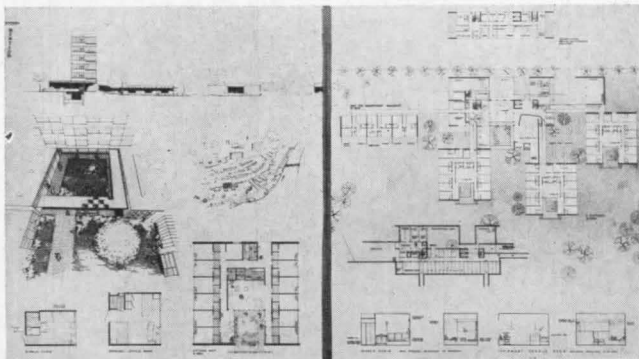

## CREDITS IN HOME FOR THE AGED COMPETITION

In the presentation published in the January issue of the RECORD of the prizewinning designs in the Home for the Aged Competition, there occurred in the case of two of the Honorable Mention winners a transposition of credits which the RECORD, of course, very deeply regrets. These schemes (pages 166-167 in January), shown here in photographs of their presentation boards, are correctly identified as the work of (above) Bellante & Clauss, Philadelphia; Hans G. Egli; and (right) Architects Associated, New York City; Sidney L. Katz, Taina Waisman, Joseph Blumenkranz, Richard G. Stein, Read Weber — Consultants: Costantino Nivola, Jerome L. Strauss, Patrick S. Raspante, Ricardo Scofidio. The competition was sponsored by the National Committee on the Aging of the National Social Welfare Assembly, co-sponsored by ARCHITECTURAL RECORD and The Modern Hospital

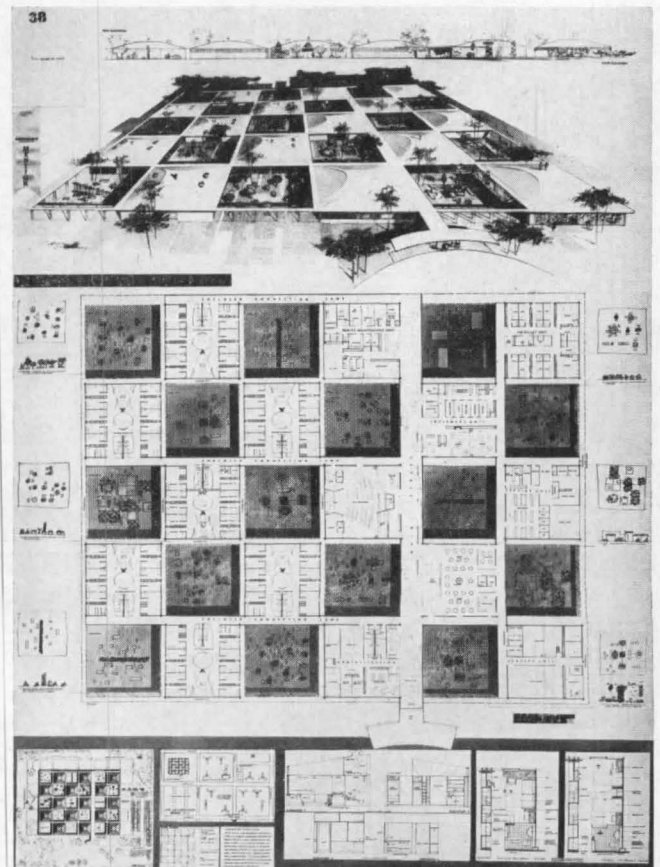

(More news on page 16B)

# Vina-Lux<sup>®</sup> FLOORS

give the first impression  
of good taste

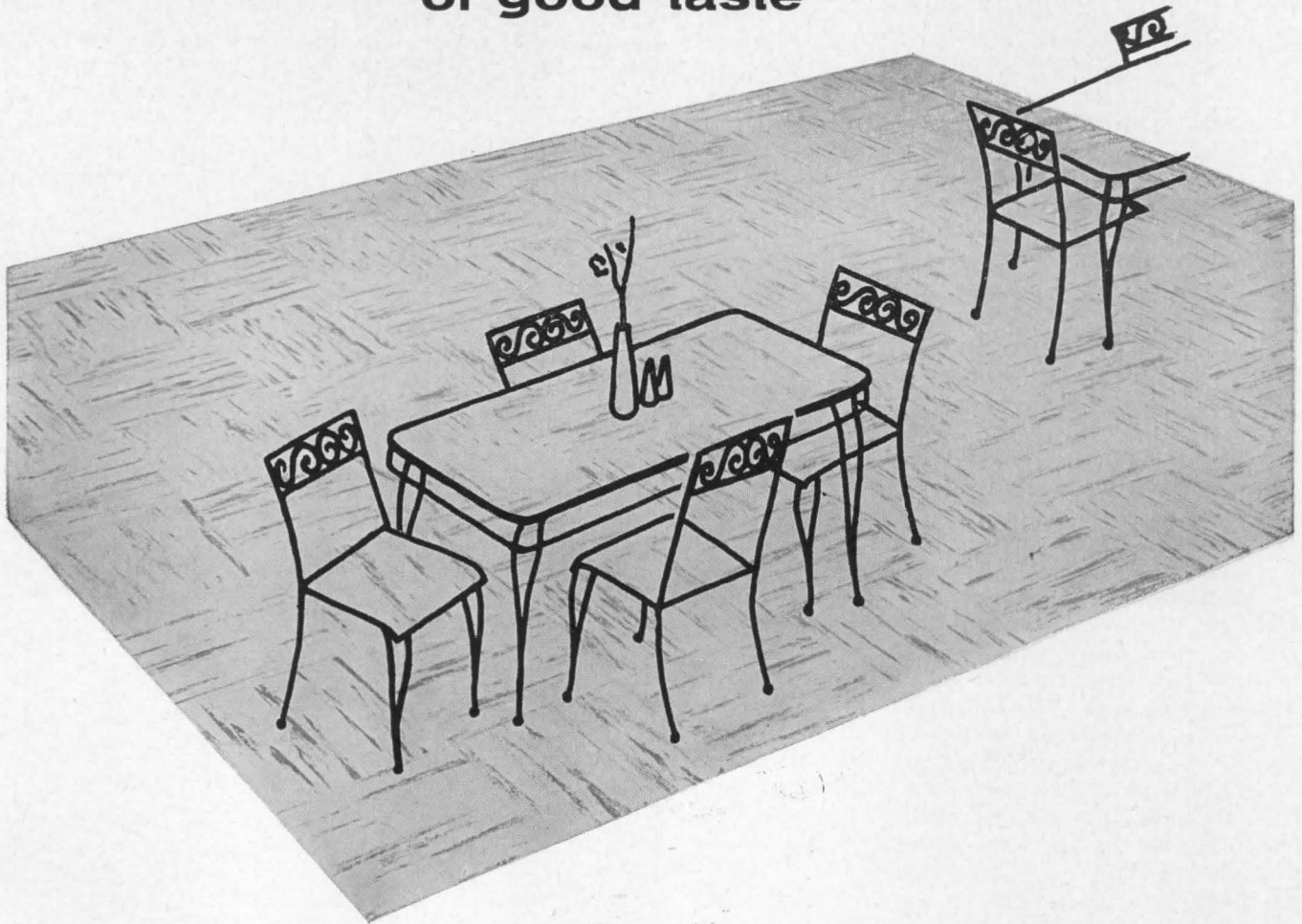

First impressions are vital in attracting restaurant trade and encouraging people to "eat out more often." A Vina-Lux floor quickly expresses the good taste that implies good food and good service. With Vina-Lux, *color* can be used to give decorative expression to the entire restaurant . . . to coordinate and key its design and furnishings.

This modern floor brings beauty and style . . . and a big bonus of practical qualities. It's the new answer to the old problem of grease and spilled foods. It's the quick answer to maintenance problems, cutting cleaning time, eliminating the need of waxing. It's *your* answer to greater freedom and inspiration in designing smarter restaurant floors.

Why not write for Vina-Lux samples and color charts?

*Pattern shown: Wintergreen*



**AZROCK PRODUCTS DIVISION • UVALDE ROCK ASPHALT CO.**

512A Frost Bank Building • San Antonio, Texas • *Makers of Vina-Lux • Azrock • Duraco • Azphlex*

**HOUSE BUILT ON RESEARCH:  
BOGOTA TRAINING PROJECT**

One of four student projects during last year's course at the Inter-American Housing Center at Bogota (see pages 193-200) produced the low-cost modular concrete house shown here as an example of training projects at the Center.

The project was conducted by Prof. René Eyheralde, a Chilean, and ten Latin American nationalities were represented among the eleven "students" — all, as required at the Center, professionals in the field of housing.

The "developmental design" method used for the design and construction of this house is a hallmark of the Center and "appears to work very well," according to the Center's new director, Eric Carlson. The method consists first in studying in isolation the various problems implied in a design program and making use of mockups which permit a full comprehension in three dimensions of the proposed solutions; then, after a "coordination period," all the separate solutions are assembled in a specimen building from which final, "proved" plans and details are prepared.

Concrete blocks of the common type readily available in Bogota were used as supporting walls and partitions, and determined the module for the entire house. Prestressed concrete beams were used for both foundation (see sections) and roof structure — the roof has inverted "T" sections supporting common blocks of slag, with a screed of concrete poured over to provide the minimum fall needed for rain water drainage. Kitchen, bath and laundry facilities are of the type traditional in the country. Cost was estimated at the equivalent of \$1000 U. S.

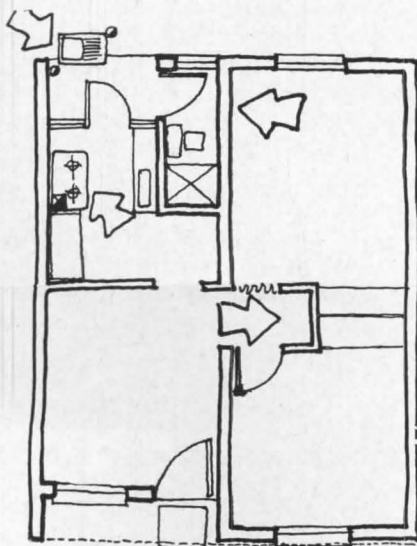
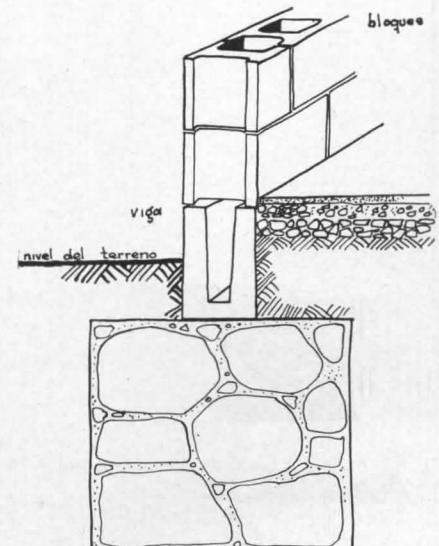
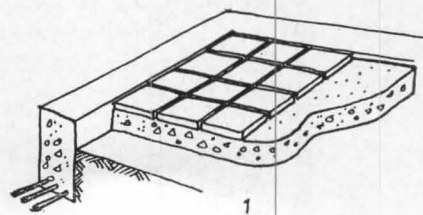
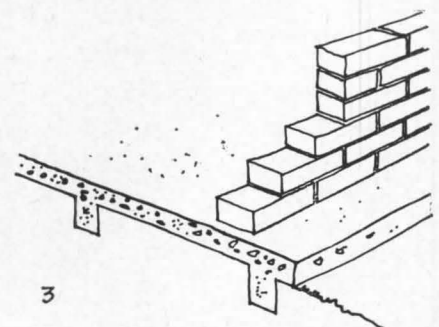
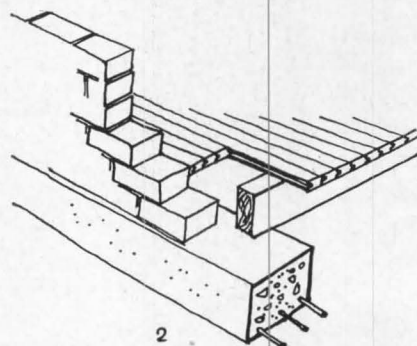
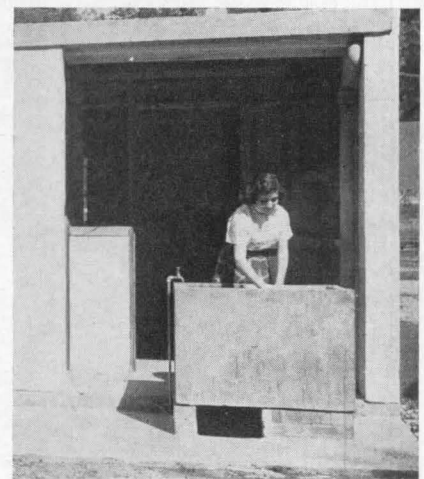
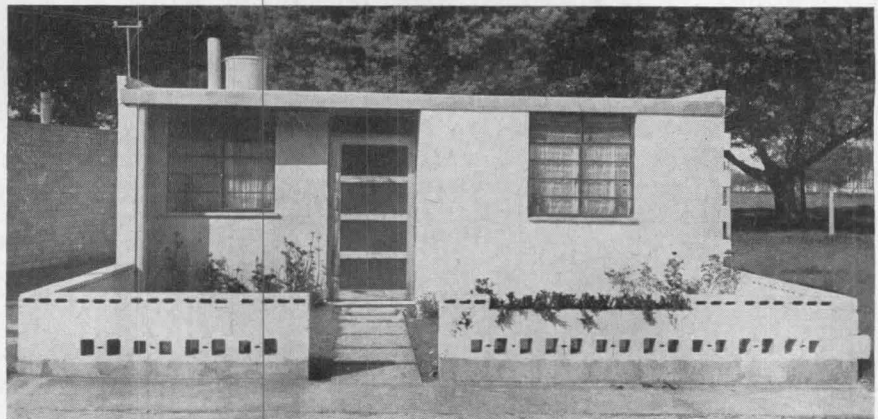

Four sections of foundation show various solutions studied and (right) the scheme finally adopted. Prefabricated "U" beams of prestressed concrete are supported on bases located at the corners of the house and at the intersections of supporting walls, a procedure followed because of the very poor bearing quality of the ground. Floors are laid on a layer of earth covered by a thin screed of ordinary concrete



*Design for Hospital Entrance by Belluschi and Skidmore, Owings & Merrill*

## "CERAMIC TILE...FOR PERMANENT COLOR CLARITY, DURABILITY AND MINIMUM MAINTENANCE"

**BELLUSCHI AND SKIDMORE, OWINGS & MERRILL**

Belluschi and Skidmore, Owings & Merrill bypassed the institutional look . . . made ceramic tile color a therapeutic factor in this refreshing hospital entrance design . . . and guaranteed long life and low maintenance with well-considered ceramic tile specifications.

Tile's unique beauty, design flexibility and durability were all fully recognized. Imaginative use of standard tile units achieved an air of relaxation, efficiency and rigid cleanliness. Beauty is only the eye-catching part of the story. Consider the design from a hospital trustee "cost-accounting" viewpoint.

There's a tile floor to fight foot traffic for years with minimum wear and maintenance. The glazed tile wall at the right will

gleam brightly on generations of patients. Take the inside-outside penetrating wall in the center—vivid proof of how tile's fired-fast colors can take extreme exposures. Note the smaller tiles facing the front of the reception desk. These fireproof surfaces will never need waxing, costly maintenance or replacement.

If you demand beauty, durability, long-range economy or design flexibility, you will find that ceramic tile provides them all. Your local tile contractor will give the details on the wide range of colors, textures and sizes. Specify ceramic tile on your next residential, institutional or commercial building. Both you and your client will be glad you did.

*The Modern Style is*

**CERAMIC**  
*tile*

**TILE COUNCIL OF AMERICA, Inc., Room 3401, 10 East 40th St., N. Y. 16, N. Y. or Room 933, 727 W. 7th St., Los Angeles, Calif.**

**PARTICIPATING COMPANIES:** American Encaustic Tiling Co., Inc. • Atlantic Tile Mfg. Co. • Cambridge Tile Mfg. Co. • Carlyle Tile Co. • General Tile Co. • Gladding, McBean and Co. • Jordan Tile Mfg. Co. • Lone Star Ceramics Co. • Monarch Tile Mfg. Inc. • Mosaic Tile Co. • Murray Tile Co., Inc. • National Tile & Mfg. Co. • Olean Tile Co. • Pacific Tile and Porcelain Co. • Pomona Tile Mfg. Co. • Ridgeway Tile Co. • Robertson Mfg. Co. • Royal Tile Mfg. Co. • Sparta Ceramic Co. • Stylon Corp. • Stylon Southern Corp. • Summitville Tiles, Inc. • Texeramics, Inc. • United States Ceramic Tile Co. • Wenzel Tile Co. • Winburn Tile Mfg. Co.

ON THE HORIZON: MORE OFFICE BUILDINGS FOR BOOMING ONTARIO

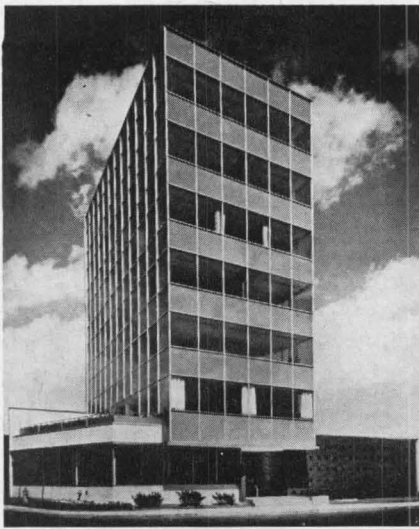

Max Fleet

**TALL ONES FOR TORONTO**— Two major office buildings in fast growing Toronto are projects of Anglo Canada Fire and General Insurance Company (left) and Canadawide Investments Ltd. (at right). Prof. James A. Murray of the University of Toronto School of Architecture is architect for the Anglo Canada building. The Canadawide Investments building will be the first in Toronto to incorporate multi-story parking facilities; it will have a five-story parking section. Cost is estimated at \$25 million. Peter Caspari is the architect

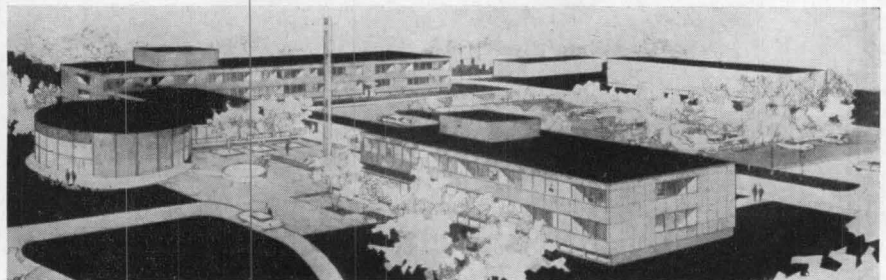
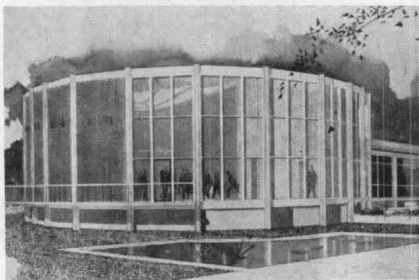

**MUNICIPAL CAMPUS**— The complex of buildings designed by architects

Shore and Moffat for Etobicoke Township, Ont., will consolidate the municipal

and Board of Education offices. Estimated cost: \$1,750,000. Closeup: Council hall

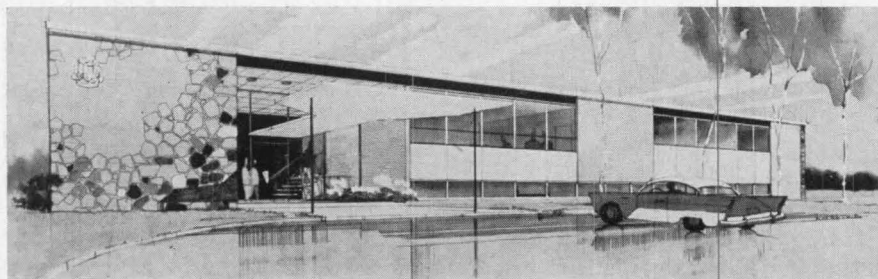

**MUNICIPAL SPLIT-LEVEL**— The new headquarters building for King Township's Council and municipal staff will have brick and marble exterior walls on a steel frame, utilizes split-level plan to get maximum space in a long, low building. Architect is Irving D. Boigon

**OFFICE ADJUNCT**— Confederation Life Association of Toronto has always preferred to provide staff facilities for eating, recreation, etc., in a building quite separate from its offices, and last year opened this new "Staff House" in Toronto. With the separation of facilities, not only are business and pleasure not mixed, but the staff is intended to benefit from the change of pace afforded by the move to other scenes for lunch-time and after-hours activities. Architects were Marani and Morris

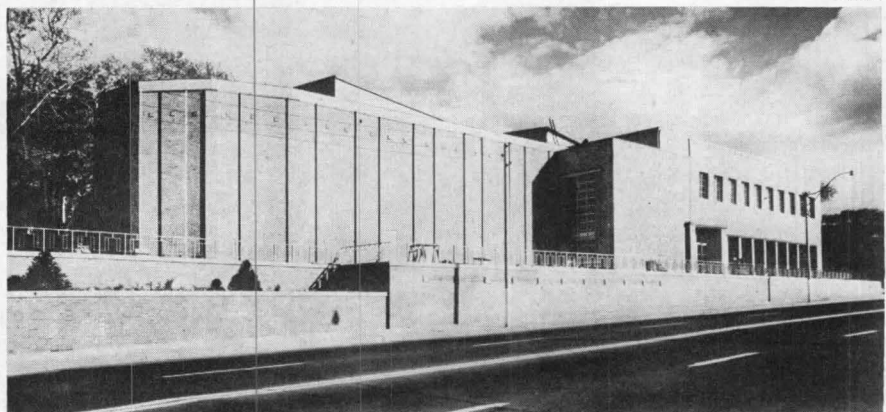

Panda

(Continued on page 40)



Weldwood walnut paneling in President's office, First National Bank of Phoenix, Phoenix, Arizona. Architect: William D. Reed; Installation: Adelta Showcase & Fixture Mfg. Co.

relaxed setting for important decisions . . .

## Achieve it beautifully with wood paneling by Weldwood

Achieve it easily too. Weldwood paneling is simple to install . . . and the cost is moderate. A Weldwood Architect's Service Representative will help you choose from our large collection of selected woods.

The mounting pressure of business provides an opportunity for the imaginative architect or decorator. For, with fine wood paneling, you can create a calm, relaxing setting . . . ideal for transacting business. At the same time the quiet beauty of wood lends great dignity to the surroundings. These characteristics of fine woods are highly valued by modern business.

Weldwood offers a wide choice of interesting woods, from "standards" like walnut, mahogany, oak and cherry, to exotic and imported species like Brazilian rosewood, teak and Korina®.

For very special jobs you'll be interested in custom, blueprint-matched Weldwood paneling. Or architectural-grade sequence-matched sets which are available in a variety of species from stock.

Contact your Weldwood Architect's Service Representative when you start planning your next job. There is no obligation. You can see a full selection of Weldwood paneling at any of our 87 branch offices in major cities. In New York, at Weldwood Building, 55 W. 44th St., and at Architects Sample Corp. In Canada: Weldwood Plywood, Ltd.



# Weldwood®

## Wood Paneling

*A product of*

**UNITED STATES PLYWOOD CORPORATION**

*Weldwood—The Best Known Name in Plywood*

AR3-57

**United States Plywood Corporation**

**Weldwood Building, 55 West 44th St., New York 36, N.Y.**

Please send me a free copy of your new 28-page booklet "Weldwood Functional Beauty for Business and Institutional Interiors."

NAME .....

FIRM .....

ADDRESS .....

CITY ..... STATE .....

## THE RECORD REPORTS NEWS FROM CANADA

(Continued from page 40)

from the next few months, there will be a good supply of funds available for housing."

Earlier, A. Turner Bone of Montreal, C.C.A. president, had expressed the belief that a 1957 construction volume increase of five to ten per cent is likely, though he also expected a housing drop.

### ENGINEERS SET UP PLAN TO QUALIFY TECHNICIANS

A plan to establish standards of qualification for engineering technicians and to set up a system of voluntary registration for them was approved by the 15,000-member Association of Professional Engineers of Ontario at its annual meeting in Toronto January 26.

Technicians are to be examined by the Association and classified in four grades, determined by their educational qualifications and technical experience. In time it is expected that many may qual-

ify as full-fledged members.

New president of the Association, largest body of professional engineers in Canada, is John Holloway Fox, O.B.E., of Toronto. With him on the executive council will be the immediate past president, Merritt W. Hotchkin of Kirkland Lake; Charles T. Carson of Walkerville, first vice president; and Walter J. Gilson of Toronto.

Two councillors were also elected to represent each of the five engineering branches: (civil) J. H. Irvine, Ottawa, and A. W. F. McQueen, Niagara Falls; (electrical) G. M. McHenry, London, and J. W. Holmes, Peterborough; (mechanical, aeronautical and industrial) P. E. Cavanagh, Toronto, and Edmund P. Lewis, Sarnia; (chemical and metallurgical) L. C. Sentance, Hamilton, and H. D. Culham, Toronto; (mining) C. P. Jenney, Toronto, and M. L. Urquhart, Schumacher.

The Association's permanent officers are T. M. Medland, executive director, J. M. Muir, secretary-treasurer and registrar, T. C. Keefer, field secretary, and B. H. Goodings, field representative, all of Toronto.

### NEWS NOTES

The Royal Architectural Institute of Canada has announced that no Massey Medals Competition will be held in 1957. . . . A \$1250 architectural competition for a community art gallery has been announced by Graham Bell Ltd. of Streetsville, Ont.; object is to encourage greater

(Continued on page 46)

## WALL POCKET DOORS

*make better  
use of the  
space inside  
and outside  
the room*

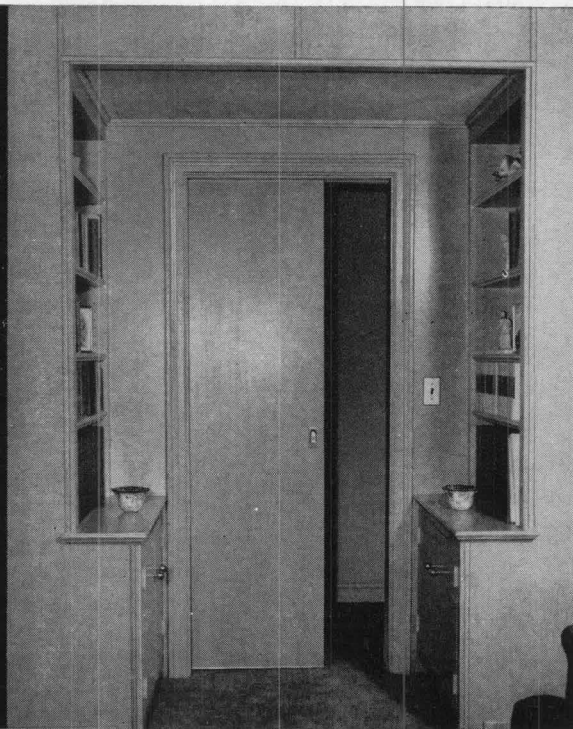

## **Sterling** Pocket Door T-Frame

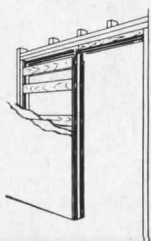

Write for complete details of the Sterling Pocket Door T-Frame . . . modern structural hardware for modern buildings.

This *all-steel* Pocket Door T-Frame makes the wall rigid and warp-proof . . . provides the simplest and lowest-cost pocket door installation. It enables you to plan a door where it really belongs . . . *in the wall when not in use!* Not only will many square feet of space be saved, but doorways can be made as wide as desired without cramping quarters.

OUR CATALOG IS IN SWEET'S FILES

## John Sterling Corporation

Formerly Sterling Hardware Mfg. Co.  
2345 West Nelson Street • Chicago 18, Illinois



Architectural Institute of British Columbia's new officers — (standing) Prof. Fred Lasserre, U.B.C. architecture head, and government representative on the Council; C. E. Pratt and Kenneth McKinley, also Council members. (Seated) Robert W. Siddall, Council member; Clive D. Campbell, president; John L. Davies, past president and Council member-at-large



# For a Protected Learning Environment

## COLD WINDOW WALLS CREATE 2 PROBLEMS

WIND-O-LINE RADIATION MAKES THE DIFFERENCE!

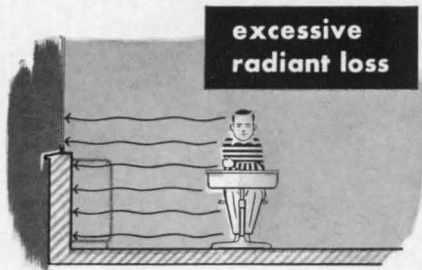

Without Wind-o-line, pupils seated near the cold walls are uncomfortable because of excessive body heat loss—even with a 70° room air temperature.

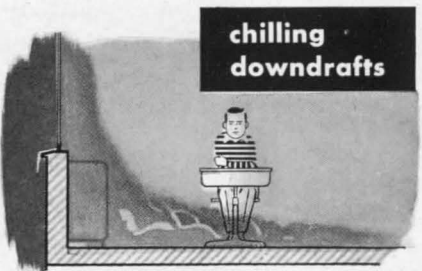

Downdrafts from the cold window wall add to the discomfort, forming pools of chilling air around the ankles of pupils seated near the cold surface.

The Nesbitt Series Hot Water Wind-o-line System provides the protected learning environment at proven lower costs.

You cannot ignore the need for protective radiation along the full length of cold window walls. Remember that indoor thermal comfort is related not only to the room air temperature, but to the temperature of the surrounding floors, windows and walls as well. For the fully protected thermal environment in your school, specify Nesbitt Syncretizers with Wind-o-line Radiation.

## WIND-O-LINE RADIATION SOLVES BOTH PROBLEMS

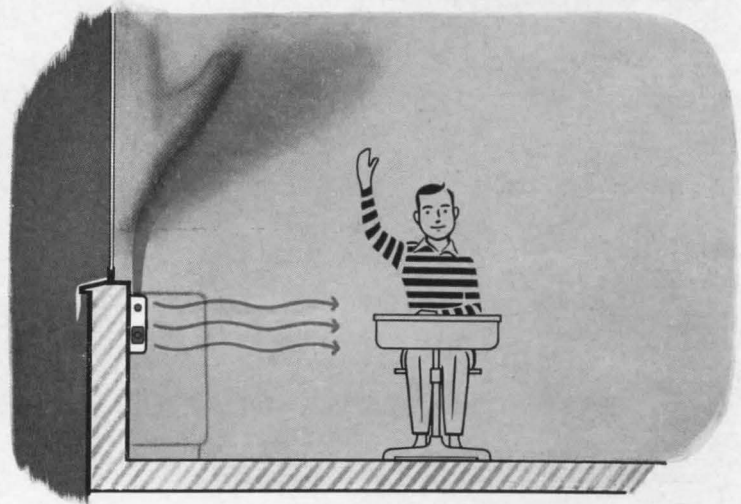

With Wind-o-line installed along the exposed surfaces, floor, window and wall temperatures are raised; radiant heat protects against excessive loss of body heat; convected heat all along the sill warms the chilling downdraft, diverting it above the heads of the pupils. Wind-o-line Radiation functions only when and as needed, augmenting the work of the Syncretizer unit ventilator to provide a fully protected learning environment.

For more complete information send for Publication 101—  
more learning per school dollar.



# Nesbitt

## Syncretizers with Wind-o-line

Made and sold by John J. Nesbitt, Inc., Philadelphia 36, Pa. Sold also by American Blower Corporation and American-Standard Products (Canada) Ltd.

ONE FIXTURE:

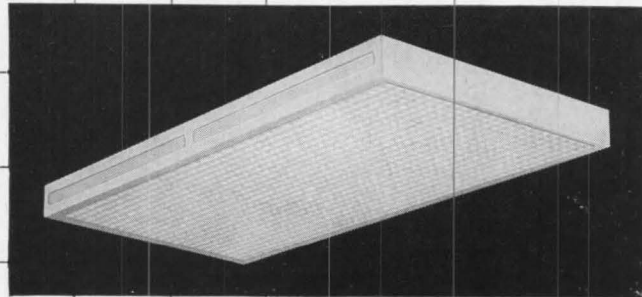
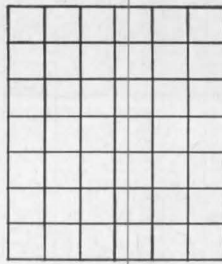
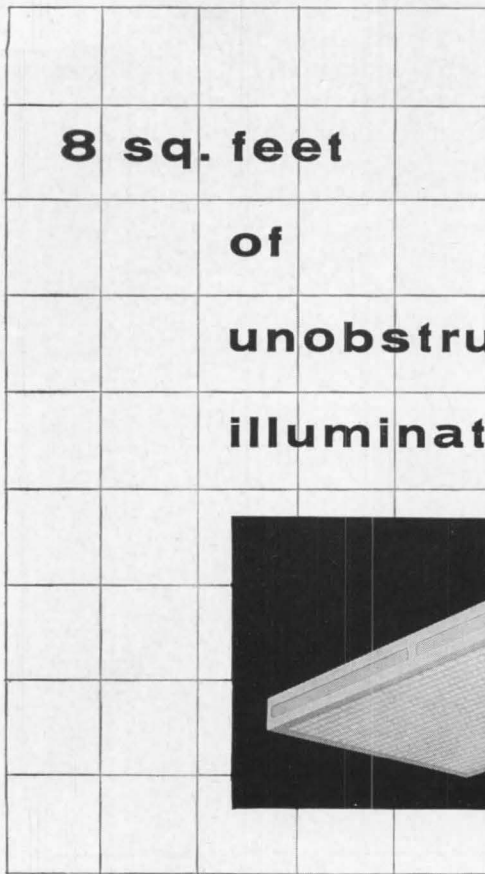

## NEW electro silv-a-king surf-a-lite

Our new Surf-A-Lite achieves a uniform luminosity over its entire 2 ft. x 4 ft. surface—free of visible metal bands and dark islands. The entire fixture presents a smooth appearance with no visible screws or latches when the "Magic Frame" door is closed.

Through the use of various diffusing media the desired comfort ratio can be obtained for any installation. And when used with our exclusive ½ sq. "Poly Cube" polystyrene louver it achieves a glowing, jewel like appearance which you will find adds to the beauty of the most luxurious interior.

**SHALLOW 3½" FIXTURE mounts flush to ceiling . . . modular design for unlimited variety of lighting patterns.**

Available in two and four lamp units, 12", 17", or 24" wide—4-ft. or 8-ft. long...in ½" sq. "Poly-Cube" polystyrene louver, pattern #70 low brightness lens panel or Alba Glass diffusers with metal or plastic sides.

Complete specification and installation data available upon request.



**electro silv-a-king corporation**

1535 S. Paulina Street, Chicago 8, Ill.  
Spruce and Water Sts., Reading, Pa.

**DESIGNERS AND MANUFACTURERS OF THE FINEST IN LIGHTING**

## THE RECORD REPORTS

### NEWS FROM CANADA

(Continued from page 44)

use of porcelain enamel, decoratively and/or as a basic structural element. Details from: Professional Adviser Prof. James A. Murray, Editor, *The Canadian Architect*, P. O. Box 4000, Terminal A, Toronto 1, Ont. . . . **Canadian Housing Design Council Awards** for merchant builders' houses will be made in Ottawa on April 3, by Governor General Massey. . . . **Architects in the News:** *F. W. Nichols* of Victoria appeared on the program of the National House Builders Association Jan. 9-11 get-together in Montreal. *Prof. Raymond T. Affleck* of Montreal, *Mayor John Pratt* of Dorval, Que., *S. A. Gitterman* of Ottawa and *Prof. S. R. Kent* of the University of Toronto were on the program of the National Concrete Products Association convention in the same city. . . . Incorporation of the **Newfoundland Association of Architects** has been announced. . . . A talk by architect Richard Neutra of Los Angeles, "Future Architecture—A Most Human Affair," climaxed **Session '57**, sponsored at the Banff School of Fine Arts by the Alberta Association of Architects. Two newcomers to the conference—instituted last year as "Session '56"—were George A. Lundberg, sociologist, and Norbett L. Mintz, psychologist and anthropologist. Professor Lundberg, head of the Sociology Department of the University of Washington, discussed the social implications of architecture, and Mr. Mintz, a member of the faculty of Brandeis University, Waltham, Mass., discussed the results of experiments into the "Effects of Esthetic Surroundings."

#### Contracts Awarded: Comparative Figures\*



\*Compiled by the Editor and staff of *The Building Reporter*, from information collected by Maclean Building Reports

(More news on page 48)



## ON TOP OF THE LADDER

PROFESSIONAL PAINTERS everywhere realize that the success or failure of a particular job is directly dependent upon their skill and the quality of paints they have with them . . . on top of the ladder.

And we at Devoe, who have devoted the past 203 years exclusively to the paint industry, are extremely gratified and proud of the confidence you have shown in Devoe products.

But we are not content to rest on our laurels. Today, Devoe is investing millions of dollars in research, seeking to discover new and better products, searching for higher quality control and advancing the technical operation of our plants.

Outstanding products which are "firsts" with Devoe are—Wonder-Pruf Masonry Finish (pat. pending), the latest in wall-sealing finishes; Vinyl Wonder-Tones, the world's fastest paint; and improved Wonder-matic Colors that really sell and satisfy customers.

Contact your Devoe supplier today . . . his aim and ours is to keep you and your crew "on top of the ladder."



# DEVOE

**203 years of paint leadership!**

**DEVOE & RAYNOLDS COMPANY, INC.**

Atlanta • Boston • Chicago • Cincinnati • Dallas • Denver • Los Angeles • Louisville • New York

**SCHOOL MESSAGE PROPOSES FOUR-YEAR \$2 BILLION AID**

Congress late in January received the President's special message asking for quick action on legislation to provide Federal aid to the states and local school districts for construction of new schools, and outlining a \$2 billion program "to accomplish in four years what last year's proposal would have done in five, since one year has already been lost."

The message generated anew all the old arguments over Federal intervention in the state construction program and probably provided Congress with its first major legislative consideration of the new session. It was couched in terms of greater urgency than previous White House messages on the same subject because, as the President was at pains to point out, a full year had been lost in the effort to catch up with the demands for

school housing. The final session of the 84th Congress failed to act on legislation after the House adopted the Powell segregation amendment to the school construction bill, then defeated the entire measure. The Senate did not act on the matter at all after that time.

The 1957 program proposes four kinds of aid:

1. Grants to states at the rate of \$325 million annually for four years, adding up to \$1.3 billion. The money would go to assist in construction of public schools in financially needy districts. Allotment would be by number of school-age children and state income per child. The Federal money would be matched by the neediest states and doubled by the least needy — in the first year from state or local sources, or both, and thereafter from state sources alone. The combined Federal-state funds would go to needy local districts with priority given to projects that would relieve half-day sessions, overcrowding, and other major deficiencies. This phase of the program is designed to increase incentive for states to support school construction. It is also the one on which the partisan battle is likely to turn (quite aside from questions of segregation or religious controversy which may be raised). The Democrats are generally for a straight 50-50 matching of Federal funds and allocation of funds strictly on the basis of school-age population.

2. Authorization over the four years of \$750 million for Federal purchase of all or part of an issue of bonds which local districts seek unsuccessfully to market at reasonable interest rates. School-age population would govern distribution of these funds and state agencies would determine priority of local districts based on relative need. Bonds would be purchased at the rates of long-term U. S. Treasury obligations plus one half of one per cent.

3. Federal advances to assist states to support bonds issued by state school-financing agencies for construction purposes. This applies the so-called lease-purchase plan, which has been tried for Federal construction, to school housing. Any state so choosing would set up an agency coordinated with the state education department and empowered to issue bonds. The state agency would use proceeds to finance construction of schools and local districts in turn would rent or lease the facilities. After a given period the schools would become the

(Continued on page 414)

## NATURAL SLATE . . . RIGHT

Ageless beauty . . . matchless durability . . . easy maintenance are yours when you specify slate!

Only a product of Nature can take hard usage so well. Slate has all the qualities you look for when you build . . . it is strong, sanitary, non-absorptive . . . will not contract or expand. Maintenance is low under normal usage . . . past performances show that slate outlasted the buildings in which it was installed. Never more in vogue than it is today, slate's neutral color and smooth finish create a fine, subdued effect when used in combination with the strong, clean colors so popular in modern classroom decor.

**YESTERDAY  
TODAY  
TOMORROW**



Consider the many places where slate can be used in the school building. Then for unending beauty and durability, be sure . . . specify slate. Complete information available on specific properties of slate.

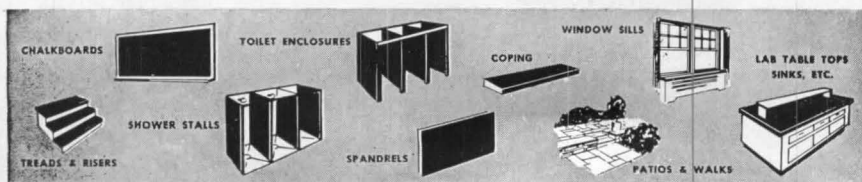

For Your Protection . . . Insist on Slate Quarried in Pennsylvania, U.S.A.

**STRUCTURAL SLATE CO.  
NATURAL SLATE BLACKBOARD CO.**

PEN ARGYL PENNSYLVANIA

natural slate . . . 500 million years in the making





## For insulation: Styrofoam brings best combination of properties

COMPARE STYROFOAM*	INSULATIONS			
	STYROFOAM	A	B	C
Low "K" factor	X		X	X
Superior Water Resistance	X	X		
High Compressive Strength	X	X		X
Light Weight	X		X	
Superior Resistance to rot and vermin	X	X		
Easy handling and fabrication	X			
Low-cost installation	X		X	
Lowest cost per year	X			

Permanent "K" factor average, 0.25. Avg. density, 1.8 lbs. per cu. ft. No odor. No food value. Pleasant to work with. Fabricates with common tools. Does not crumble or settle.

### *Cold storage plant's experience proves it!*



Eleven years ago, Flint Cold Storage Co., a large Flint, Michigan, firm, used Styrofoam (a Dow plastic foam) to assure superior insulation in its original plant. Many additions have been made since then—including a very low temperature fruit freezing plant. And Styrofoam has been used in every case (see photo)

for both equipment and building insulation.

Flint's Russell Soule writes, "We are heartily endorsing it to everyone for its low cost, high insulation efficiency, as well as its ease of installation." For complete information write THE DOW CHEMICAL COMPANY, Midland, Michigan—Plastics Sales Department PL1700M.

\*Styrofoam is a registered trademark of The Dow Chemical Company

YOU CAN DEFEND ON



# THE RECORD REPORTS: CONSTRUCTION COST INDEXES

Labor and Materials

U. S. average 1926-1929 = 100

Presented by Clyde Shute, manager, Statistical and Research Division, F. W. Dodge Corp., from data compiled by E. H. Boeckh & Assoc., Inc.

## NEW YORK

## ATLANTA

Period	Residential		Apts., Hotels Office Bldgs. Brick and Concr.	Commercial and Factory Bldgs. Brick and Concr.		Brick and Steel	Residential		Apts., Hotels Office Bldgs. Brick and Concr.	Commercial and Factory Bldgs. Brick and Steel	
	Brick	Frame		Brick	Frame		Brick	Frame		Brick	Frame
1930	127.0	126.7	124.1	128.0	123.6		82.1	80.9	84.5	86.1	83.6
1935	93.8	91.3	104.7	108.5	105.5		72.3	67.9	84.0	87.1	85.1
1939	123.5	122.4	130.7	133.4	130.1		86.3	83.1	95.1	97.4	94.7
1946	181.8	182.4	177.2	179.0	174.8		148.1	149.2	136.8	136.4	135.1
1947	219.3	222.0	207.6	207.5	203.8		180.4	184.0	158.1	157.1	158.0
1948	250.1	251.6	239.4	242.2	235.6		199.2	202.5	178.8	178.8	178.8
1949	243.7	240.8	242.8	246.4	240.0		189.3	189.9	180.6	180.8	177.5
1950	256.2	254.5	249.5	251.5	248.0		194.3	196.2	185.4	183.7	185.0
1951	273.2	271.3	263.7	265.2	262.2		212.8	214.6	204.2	202.8	205.0
1952	278.2	274.8	271.9	274.9	271.8		218.8	221.0	212.8	210.1	214.3
1953	281.3	277.2	281.0	286.0	282.0		223.3	224.6	221.3	221.8	223.0
1954	285.0	278.2	293.0	300.6	295.4		219.6	219.1	223.5	225.2	225.4
1955	293.1	286.0	300.0	308.3	302.4		225.3	225.1	229.0	231.5	231.8
Oct. 1956	313.0	303.8	324.1	334.7	329.2		239.7	238.0	245.8	248.2	252.9
Nov. 1956	313.2	304.0	324.4	334.9	329.4		239.8	238.1	245.5	248.1	250.8
Dec. 1956	316.0	306.6	327.9	338.7	332.0		239.8	238.1	245.5	248.1	250.8
	% increase over 1939			% increase over 1939			% increase over 1939			% increase over 1939	
Dec. 1956	155.9	150.5	150.9	153.9	155.2		177.9	186.5	158.1	154.7	164.8

## ST. LOUIS

## SAN FRANCISCO

1930	108.9	108.3	112.4	115.3	111.3	90.8	86.8	100.4	104.9	100.4	
1935	95.1	90.1	104.1	108.3	105.4	89.5	84.5	96.4	103.7	99.7	
1939	110.2	107.0	118.7	119.8	119.0	105.6	99.3	117.4	121.9	116.5	
1946	167.1	167.4	159.1	161.1	158.1	159.7	157.5	157.9	159.3	160.0	
1947	202.4	203.8	183.9	184.2	184.0	193.1	191.6	183.7	186.8	186.9	
1948	227.9	231.2	207.7	210.0	208.1	218.9	216.6	208.3	214.7	211.1	
1949	221.4	220.7	212.8	215.7	213.6	213.0	207.1	214.0	219.8	216.1	
1950	232.8	230.7	221.9	225.3	222.8	227.0	223.1	222.4	224.5	222.6	
1951	252.0	248.3	238.5	240.9	239.0	245.2	240.4	239.6	243.1	243.1	
1952	259.1	253.2	249.7	255.0	249.6	250.2	245.0	245.6	248.7	249.6	
1953	263.4	256.4	259.0	267.6	259.2	255.2	257.2	256.6	261.0	259.7	
1954	266.6	260.2	263.7	273.3	266.2	257.4	249.2	264.1	272.5	267.2	
1955	273.3	266.5	272.2	281.3	276.5	268.0	259.6	275.0	284.4	279.6	
Oct. 1956	289.1	280.5	289.2	300.4	296.3	281.0	271.8	293.4	302.5	301.0	
Nov. 1956	289.3	280.7	289.5	300.6	296.5	282.6	272.8	295.8	306.8	302.9	
Dec. 1956	289.7	281.2	289.9	300.8	297.2	281.9	271.9	295.6	306.6	302.5	
	% increase over 1939			% increase over 1939			% increase over 1939			% increase over 1939	
Dec. 1956	162.9	162.8	144.2	151.1	149.7	167.0	173.8	151.8	151.5	159.7	

Cost comparisons, as percentage differences for any particular type of construction, are possible between localities, or periods of time within the same city, by dividing the difference between the two index numbers by one of them; i.e.:  
 index for city A = 110  
 index for city B = 95  
 (both indexes must be for the same type of construction).

Then: costs in A are approximately 16 per cent higher than in B.

$$\frac{110-95}{95} = 0.158$$

Conversely: costs in B are approximately 14 per cent lower than in A.

$$\frac{110-95}{110} = 0.136$$

Cost comparisons cannot be made between different types of construction because the index numbers for each type relate to a different U. S. average for 1926-29.

Material prices and wage rates used in the current indexes make no allowance for payments in excess of published list prices, thus indexes reflect minimum costs and not necessarily actual costs.

# specified Building!



Here's an interior view showing a small part of the installation of Gold Seal Inlaid Linoleum. Actually, about 3½ acres of floor space are covered with this ⅛" burlap-backed "Veltone."

**M**ORE than 148,000 square feet of Gold Seal Veltone® ⅛" Inlaid Linoleum has been specified and installed in the new Maine State Office Building at Augusta, Maine.

Originated by Gold Seal, "Veltone" provides an attractive, long-wearing, all-over decoration for use in all public buildings, schools, hospitals, offices, etc. Veltone's excellent resiliency provides quiet and comfort under foot. The unique design of this Inlaid Linoleum literally hides foot marks . . . it's exceptionally easy to clean and keep clean because of its density and surface smoothness. This ease of maintenance naturally reduces the expense of building service and upkeep. For those who prefer the modern textured look in Inlaid Linoleum, Gold Seal offers Sequin®—⅛" thick—with all the advantages of "Veltone."

Gold Seal Vinylbest\* Tile and Gold Seal Asphalt Tile were also used in special areas such as the food and photo laboratories.

**Specifications—Gold Seal Veltone:** 6' wide yard goods, ⅛" gauge, burlap-backed. Install over suspended wood, or suspended concrete under-floors. Available in 8 colors—Pompeian Grey, Heather Tan, Spicewood, Bermuda Grey, Light Tan, Grey, Brown, Surf Green. Also made in standard gauge for residential use—in 9 colors.

**Send for Free Technical Data Book**—"Why Resilient Floors"—containing 36 pages of information to help you specify the correct resilient floor for any type of commercial, institutional or residential building. Address Architects' Service Department, Gold Seal Floors and Walls, Congoleum-Nairn Inc., Kearny, N. J.

**PROVIDE YOUR CLIENTS WITH THE FINEST IN FLOORING — SPECIFY GOLD SEAL**



#### FOR HOME...BUSINESS...INSTITUTIONS:

BY THE YARD AND TILES—Inlaid Linoleum • Nairon®  
Plastics • Vinylbest\* Tile • Cork Tile • Rubber Tile  
Asphalt Tile

PRINTED FLOOR AND WALL COVERINGS—  
Congoleum® and Congowall®

RUGS AND BROADLOOM—LoomWeve®

SATISFACTION GUARANTEED OR YOUR MONEY BACK

© 1957 CONGOLEUM-NAIRN INC., KEARNY, N. J.



FOR THE LOOK THAT'S YEARS AHEAD

**Gold Seal®**  
FLOORS AND WALLS

\*Trademark

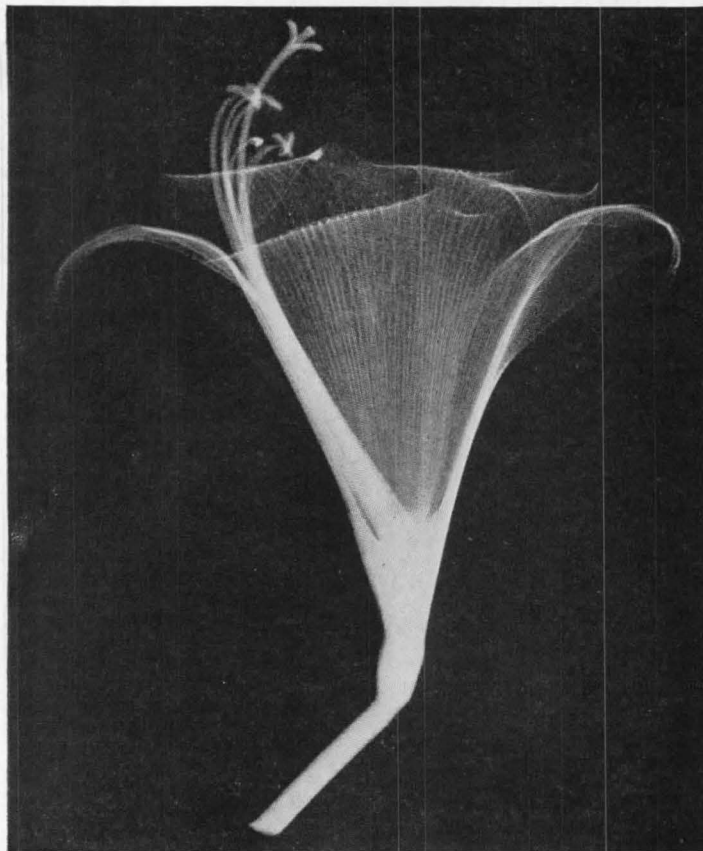

*The New Landscape.* By Gyorgy Kepes.  
Paul Theobald and Co. (Chicago) 1956.  
384 pp., 452 Illus., some color. \$15.50

**KEPE'S NEW VOLUME RELATES ART AND SCIENCE;  
VIEWS PRESENT ARTISTIC DILEMMAS AND HOPES**

By EDGAR KAUFMANN, JR.

EQUIPMENT — mechanical and electronic — pre-empts half the client's dollars, produces half the architect's fee. What's left is divided between structure and, perhaps, the art of architecture. Can architecture then expect to continue as an art or is this only a fading image, more honored in the breach? To any architect concerned with this question and similar ones, *The New Landscape* will be an essential source book, for it is filled with indications of better ways to formulate the problem, ways that permit rather than block solutions. *The New Landscape* solves no problems but it shows rapprochements between art and science, reaching toward a more complete grasp of the human condition than either has provided for our time. Not only architects but many scientists and artists are in a quandary, and Kepes' book is essentially a round-up of scouts' reports

*(Continued on page 67)*

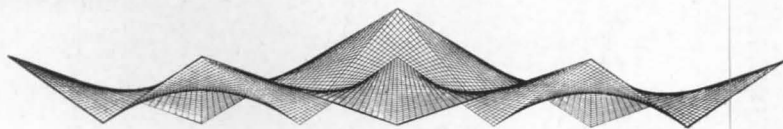



**REQUIRED READING**

*(Continued from page 62)*

on admittedly arduous escape routes to lands of promise.

In sequence Kepes indicates the convergences of art and science as they face their respective limitations; the role of symbols from child art to mathematics; the autointoxication of our world as we've built it; the increased control of scale, sensitivity and reliability in investigating the cosmos; the relatedness of pattern and process; the significance of change; the interdependence of modules and rhythms; and so on in abundant recognition of the dilemmas and hopes of our day. No final theory or dogma is proposed, no comparisons are insisted on; this remains "a book of allusions, not conclusions."

Kepes tells at once that in this new work of his, "visual images are the content, verbal statements are the illustrations." Pictures come from many sources, revealing long and impassioned research. Words are garnered with equal skill and ingenuity. Besides the generally admirable text of the author, special contributions were written by Gropius, Giedion, Neutra, Weidlinger, Charles Morris, Norbert Wiener, Katherine Lonsdale, Heinz Werner, Leger, Helion, Gabo, etc. In the first section alone (out of ten) apposite quotations are made from Aquinas, Bacon, Blake, Belluschi, Coleridge, Assirer, Delacroix, Dewey, Helmholtz, Nietzsche, Plato, Sullivan, Whitman and Wright. The pictures are equally diversified. Kepes has kept all this in context, aiming to follow a plan which he quotes from Charles S. Pierce: "Its reasoning should not form a chain which is no stronger than its weakest link, but a cable whose fibers may be ever so slender, provided they are sufficiently numerous and intimately connected."

Ten years of persistent work went into this volume; the results justify the effort. The layouts, which Kepes did himself, show time and again the rewards that can be reaped from a union of art and science. Thus the aspect of the book is one proof of the theme propounded. Here is a volume that will feed imagination for a long time.

**LETHABY SEEKS ART MOTIVES**  
BY PAMELA C. FORCEY

*Architecture, Nature and Magic.* By W. R. Lethaby. George Braziller, Inc. (N. Y.) 1956. 155 pp. Illus. \$3.95

*(Continued on page 426)*

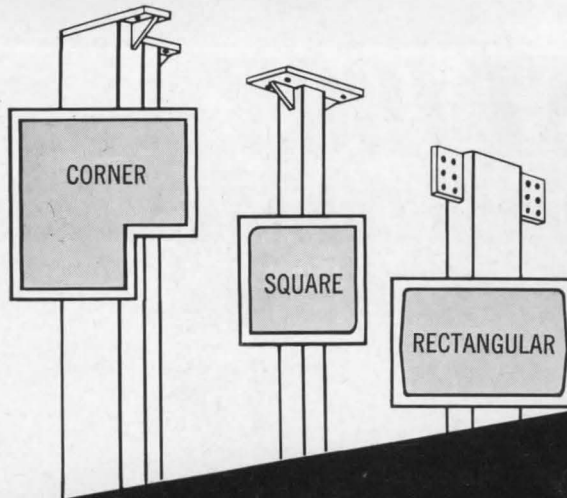

"Why didn't somebody think of this before!"

**Now You Can Specify SQUARE STEEL COLUMNS by Shlagro!**

Shlagro Square Steel Columns offer many advantages over conventional tubular columns — it's no wonder architects and engineers everywhere are saying "why didn't somebody think of that before!" The answer is simple — we did, but we've never been able to offer our Square columns in STOCK sizes until now!

Shlagro Columns are available in square, rectangular and corner shapes to fit your plans. In addition to the many listed sizes and weights (in the Shlagro Catalog), these columns can be fabricated to suit special conditions.

Specify Shlagro Square Columns — the advantages speak for themselves!



Write today for your copy of the Shlagro Stock Steel Square Column Catalog, a working "tool" with facts and figures on Shlagro Square, Rectangular and Corner Steel Columns!

- UNEQUALLED VERSATILITY!
- ADDED STRENGTH!
- SAVINGS IN LABOR AND MATERIALS!
- ELIMINATION OF EXPENSIVE FORMS!
- AND MANY OTHER BENEFICIAL FEATURES!



**SHLAGRO**

STEEL PRODUCTS CORPORATION  
SOMERVILLE, MASS.

I am interested in SHLAGRO SQUARE STEEL COLUMNS Catalog and other SHLAGRO product catalogs checked below:

<input type="checkbox"/> #200 — SQUARE STEEL COLUMNS	NAME _____  TITLE _____  Please attach to your professional letterhead and mail to:  SHLAGRO STEEL PRODUCTS CORP. SOMERVILLE, MASS.
<input type="checkbox"/> #100 — STOCK STEEL ROOF TRUSSES	
<input type="checkbox"/> #150 — STOCK STEEL LONGSPAN JOISTS	
<input type="checkbox"/> #250 — SHLAGRO SHEAR HEADS	
<input type="checkbox"/> #300 — STOCK STEEL TURNTABLES	
<input type="checkbox"/> #350 — SCAFFOLDING	
<input type="checkbox"/> #400 — STOCK STEEL EGGSHELL DESIGN STEEL ROOFS	
<input type="checkbox"/> #500 — STOCK STEEL RIGID FRAMES	
<input type="checkbox"/> #550 — STOCK STEEL VERTICAL MEMBER TRUSSES	
<input type="checkbox"/> #600 — STOCK STEEL VERTICAL LIFT DOORS	
<input type="checkbox"/> #650 — NO SHELL PRE-CAST FIREPROOF REINFORCED CONCRETE COLUMNS	
<input type="checkbox"/> #700 — STOCK STEEL FLOORSPAN GIRDERS	
<input type="checkbox"/> #750 — STOCK STEEL WELDED PIPE TRUSSES	

# *It's **CAST IRON** throughout— at the Rancho Cabrillo Subdivision San Diego, California*

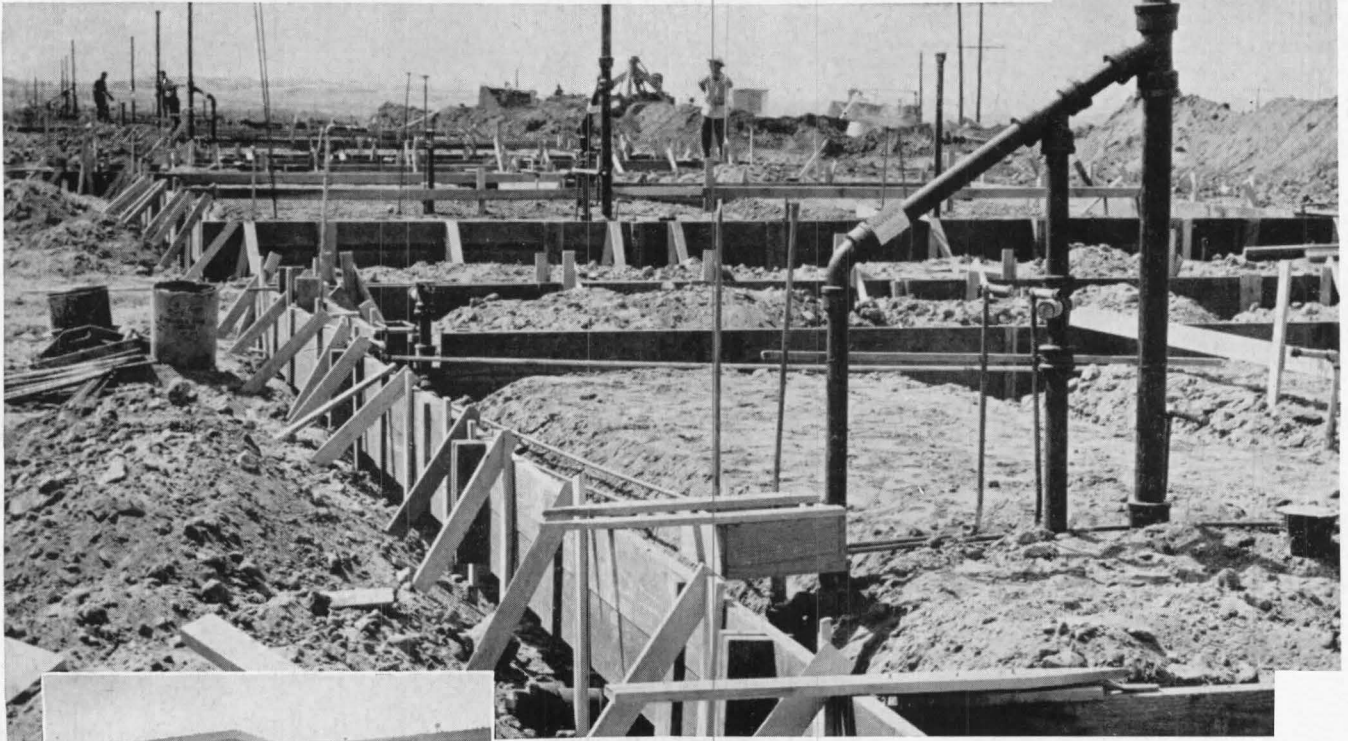

A typical home in the Rancho Cabrillo Subdivision.



Only the finest of materials was used in these homes, including beautifully appointed kitchens and cast iron soil pipe from street to roof.

Tri-W Builders, developers of the beautifully designed RANCHO CABRILLO subdivision in San Diego, California, has featured quality construction in all of the 675 modest priced but charming "Great America Homes" in this 215-acre residential area.

Throughout this large development the complete plumbing system — street to roof — is CAST IRON SOIL PIPE. This includes Cast Iron house sewers, main vents, branch vents, and drains — insuring home buyers permanent freedom from plumbing drainage trouble and expense.

Attractive homes at Rancho Cabrillo have met a wonderful reception. More than 100 were sold recently before models could be completed and opened for inspection. They feature three and four bedrooms, with 1, 1½ and 2 baths, built on lots varying in size from 60x100 feet to half an acre, with the finest of materials used throughout. All homes are fully landscaped with trees, shrubs and plants.

With 32 years' broad building experience, Tri-W Builders has a fine reputation for quality workmanship in all subdivision products — a policy that has never failed to pay in a big way.

**WOODWARD IRON COMPANY**  
WOODWARD, ALABAMA

Since 1882

Our Company does not manufacture Cast Iron Pipe, but supplies many of the nation's leading foundries with quality pig iron from which pipe is made.

MARCH 1957 ARCHITECTURAL RECORD



ARCHITECTURE, ATOMS  
AND A PEACEFUL WORLD

*A series of articles prepared with members of the Committee on Nuclear Facilities, American Institute of Architects, to animate architectural imagination in a new and challenging field*

*Drift tubes in Heavy Ion Linear Accelerator, University of California Radiation Laboratory, Berkeley*

## FOR AN ARCHITECTURE OF NUCLEAR BUILDINGS

IT IS TOO MUCH to expect that an architecture of nuclear buildings should have evolved in the brief period in which there have been such buildings. The first cyclotron was not even conceived until 1929; the first building specifically designed for an accelerator, the Cyclotron building at Berkeley, was not begun until 1941. The first reactor, the graphite "pile" at Oak Ridge, did not "go critical" until late in 1942. The short span of 15 years encompasses all that we know of the needs to be met in housing these huge and vastly powerful machines.\*

In this field of nuclear science, however, 15 years is a long time. In that time the early experimental nuclear science has become applied nuclear science, first for the weapons of war and now for the pursuits of peacetime industry; and basic research has progressed to new and constantly changing frontiers.

Change is, in fact, one of the few expected and expectable aspects of nuclear science. In the flash of an idea, a huge and costly machine, and the building to house it — neither one finished — can be made obsolete. This morning a progressively longer radius for a circular "racetrack" seems the ultimate in accelerator design; this afternoon, the idea of making particles in motion collide head-on with each other (instead of bombarding atoms at rest) explodes the morning's firm convictions. Even the neophyte soon learns that nothing is the "ultimate" in nuclear science. There is always more to learn, and new ways to learn it.

The buildings where nuclear tools — accelerator, reactor, isotope — are used present a challenge to the imagination of the architect but until 1954 very little information on them could be made public, and very little data on their design needs was available. The Atomic Energy Act of 1954 declassified much of the technical data, opened the application of nuclear knowledge to legitimate industries and businesses, and widened the scope of the architect's potential work in the field. In 10 more years, few industries and businesses will not have felt in some way the impact of nuclear energy on their methods and products.

The potential is indeed great and, for architects in particular, challenging. But it is not an easy challenge to pick up in design, for either industry or research.

Industry's part in the field is still new. As yet it does not have the backlog of experience to evaluate manufacturers' recommendations for planning, and building concepts as a result tend to become rather rigid interpretations of the recommendations.

In the field of basic research (largely carried on at installations at national laboratories and at universities) a good many buildings have been built but only

a few of them warrant architectural consideration. During World War II, when both experimental and applied research were in their infancy, speed conditioned every thought and many of the buildings put up were prefabricated, demountable structures, little more than sheds. Now that these are being replaced with permanent buildings and new buildings for new needs are being erected, it might be hoped that the criterion would be more than just permanence, that the program would be to provide more than well-constructed shelter, to plan for probable as well as immediate needs, and to create environment for working, through design of spaces derived from, and adapted to, building use.

Logical though this may sound, its accomplishment has been rare. Architecture is not the end result of totting up a score on qualifications and allotting the job to the firm whose numerical rating comes nearest a predetermined number, as is done in some agencies in selecting the architect-engineer for a project; nor can it be had when the hands and the imagination of the architect are bound by restrictions which are more of a deterrent than an aid to good and economical design. Furthermore, engineering, not architecture comes from the drafting board of an engineer. Even when the engineer has an architect on his staff, the net result is, primarily engineering, not architecture.

Nor does architecture result in the full sense unless the architect has a chance to perform his full service. It is not unusual for a technical staff member (variously an architect, an engineer, or both) to do all the probing of needs, analysis and evaluations of space and area relationships, and from these, the preliminary design of the building. When the architect is selected, he gets the commission — and a diagram of the plan he is to work with. There is little left for him, as designer, to do. This system saves time, it is true; but it robs the architect of his traditional role as designer, and the project of his independent analysis and imagination.

Perhaps these are the facts of architectural life today — but do they add up to architecture? Unless the architect has the courage, as some have had, to do his own probing, analysis and design solution even in face of the ready-prepared diagram (sometimes referred to euphemistically as a "program") these buildings will result from the thinking of others not the architect's.

But the picture is not all gloomy. With increased information, the architect will gain confidence — his own and that of his clients. Confidence, performance, good reputation, and conviction are assets anywhere; in the nuclear field they have become prerequisite.

We are at the beginning of a new and revolutionary era. The challenge in it for architecture — the mirror of man's achievements and aspirations — is to interpret its needs and means in terms of function and form, so to combine in its unique way both the high esthetic and the fully practical in one working whole.

E. K. T.

\* The first of a series of architectural implications in such buildings begins on page 186. The articles are based on information assembled by AIA's Committee on Nuclear Facilities through first hand study of AEC and other atomic energy installations throughout the country. Future articles will deal with the architectural implications in structures for reactors, medical installations, etc. Charles Haines is CNF chairman, committee members are B. E. Brazier, Thomas FitzPatrick, Alexander MacKintosh, William M. Rice, Alfred Shaw, and Eric Pawley, AIA staff.

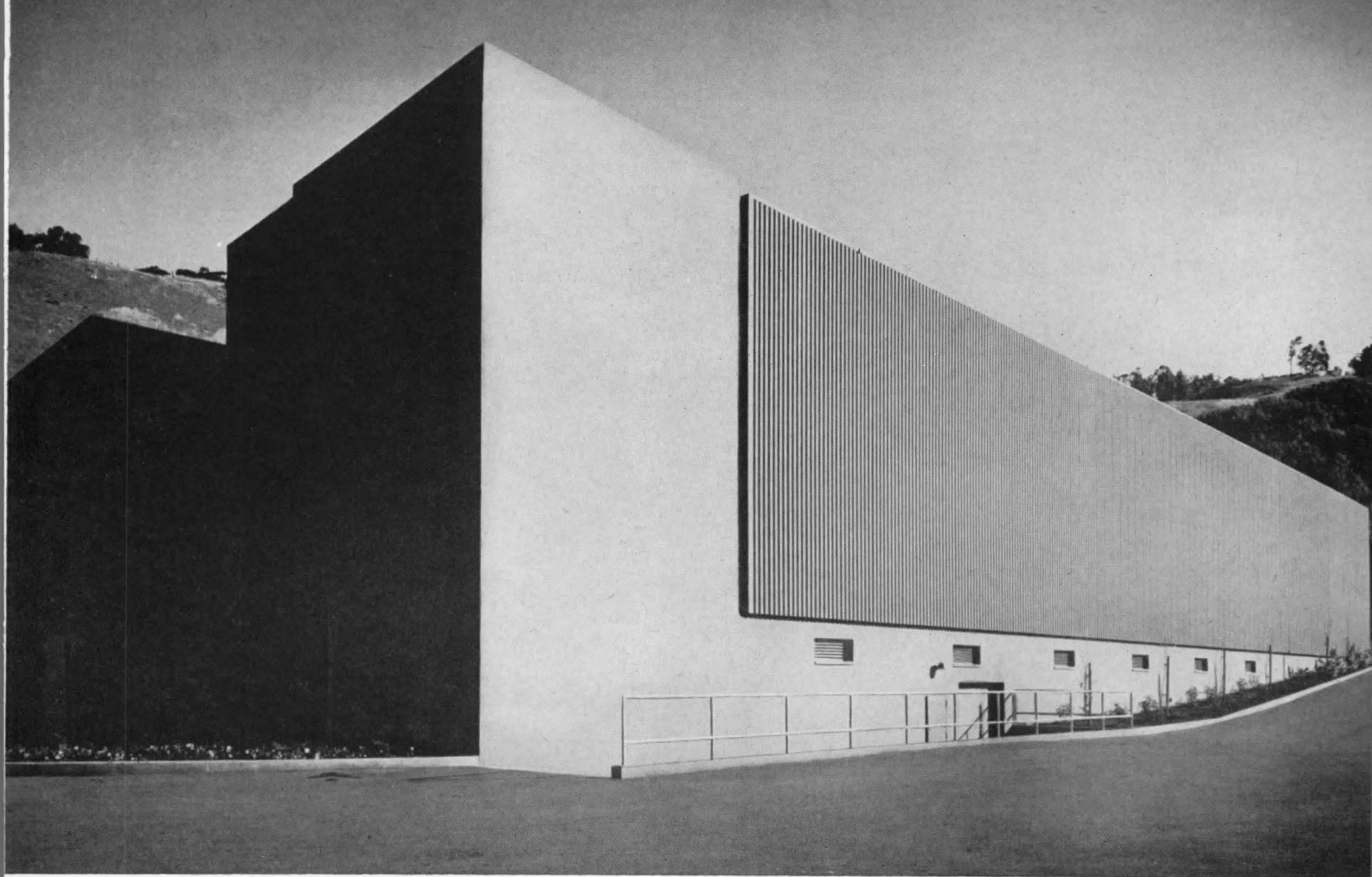

Dean Stone and Hugo Steccati, photographers

## HEAVY ION ACCELERATOR BUILDING

*University of California Radiation Laboratory\*, Berkeley*

*Corlett and Spackman, Architects*

*A clear example of the application of architectural principles to design of nuclear facilities, the Heavy Ion Accelerator Building is outstanding among accelerator buildings at research installations such as the University of California Radiation Laboratory. Concrete walls of tower end of building not only differentiate between function of "injector" located at that end of building, and accelerator which is behind steel panelled section, but act as shielding for any radiation from the injector*

THE LIST OF ELEMENTS in the periodic table has extended since 1940 from 92, uranium, to 101, mendelevium, latest of the synthetic elements. This building houses a linear accelerator of a new and special type designed to produce elements beyond mendelevium. The "bullets" to be used in "bombarding" heavy elements will be ions of nitrogen and

\* Operated under contract to U.S. Atomic Energy Commission

neighboring elements which will require very high energies to accelerate them to the speed at which their penetration of these elements will result in transmutation from one element to another.

The "Hilac" building's restricted hillside site was a considerable factor in its plan solution, but the real determinant was the use to which the machine will be put and the requirements that stem from that: tower space for injector; high bay space for accelerator; shielded area around its "useful" end; space for target and other research equipment; adjacent laboratory for chemical analysis of the short-lived elements expected; counting rooms for electronic devices to determine experimental results, especially with elements too short lived for chemical analysis; rooms for capacitors, transformers, etc.; cooling tower to keep machine, target, motors from overheating. *John Sardis, structural engineer; James Gayner, mechanical engineer.*

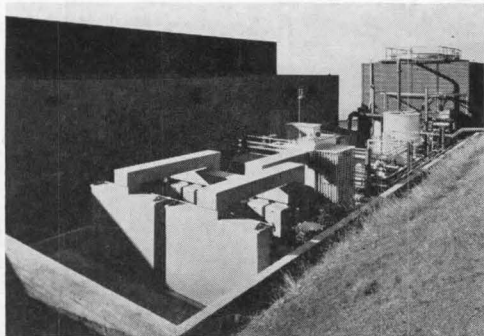
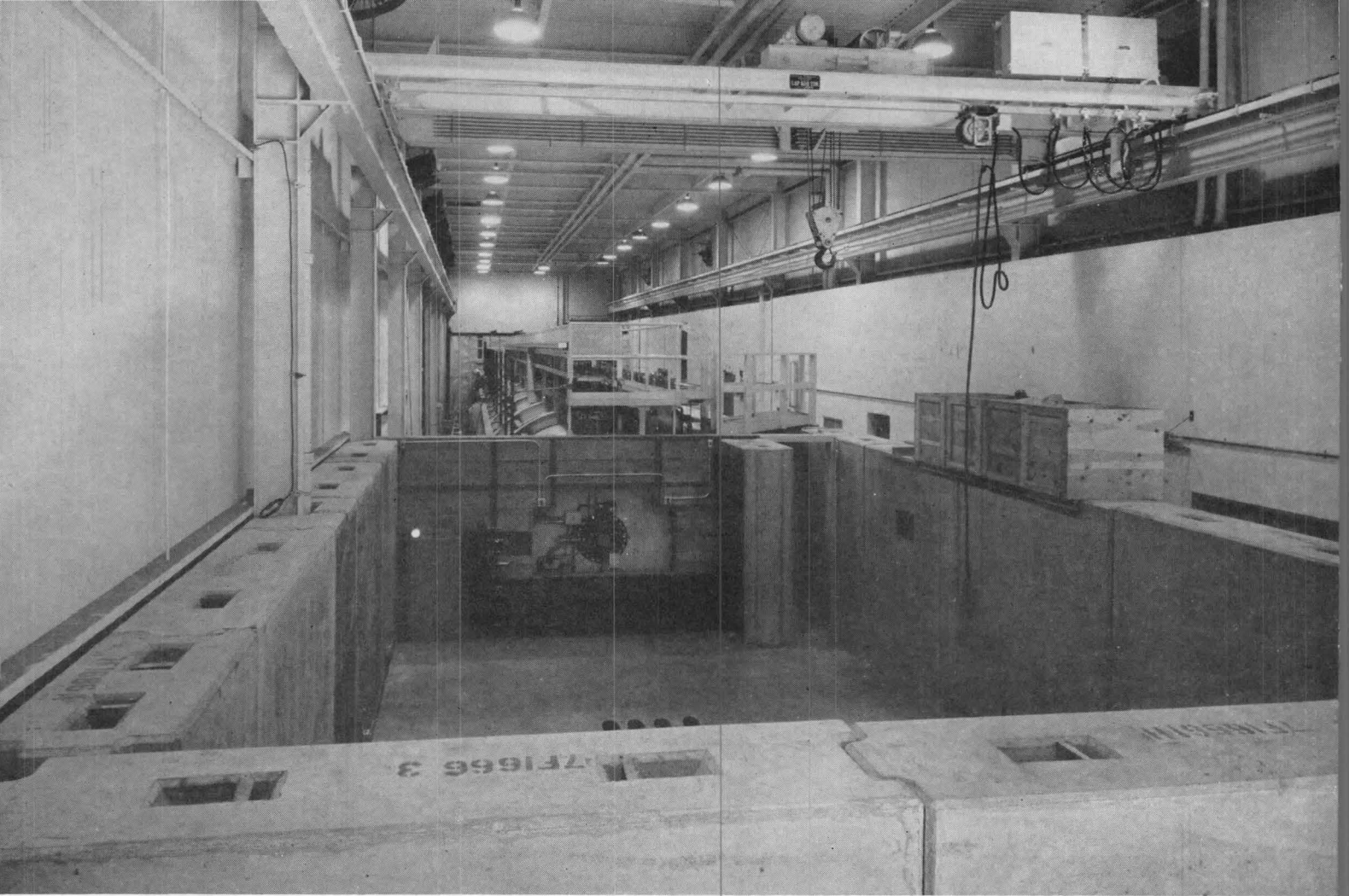

## HEAVY ION ACCELERATOR BUILDING

*Concrete panels, interlocked to trap radiation, form shielded target area or "cave" for experimental equipment. Entrance is through maze at right. Transformer pad and cooling tower, outside at rear, emphasize two inherent problems in accelerator building design: power and heat*

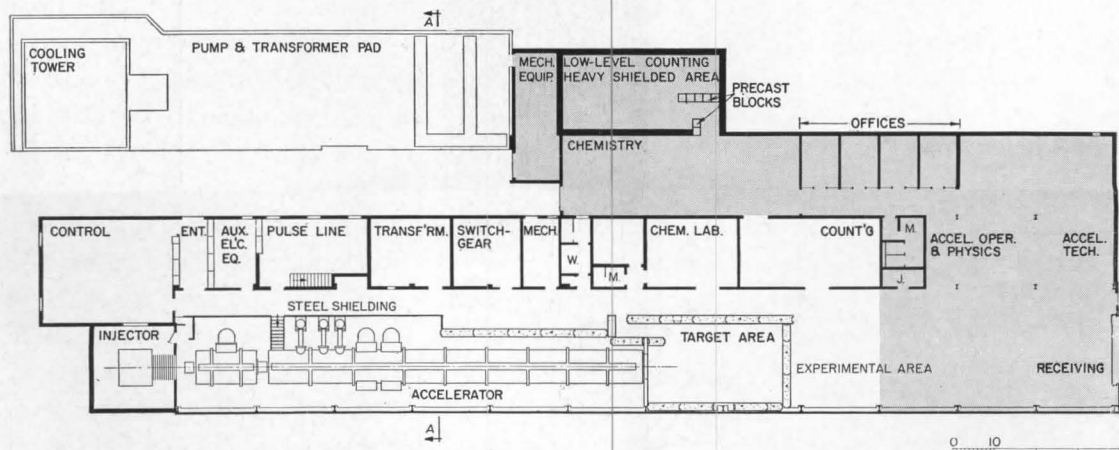

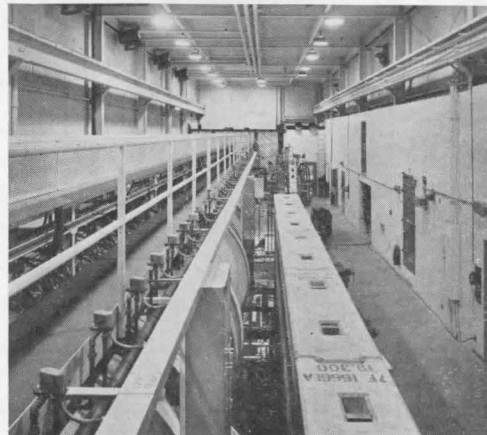
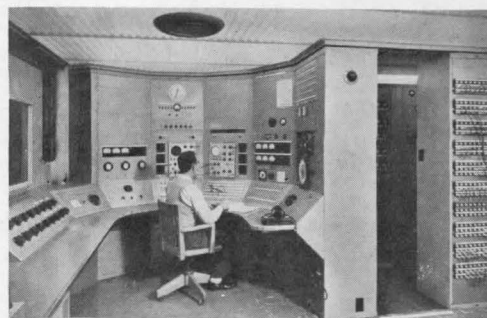
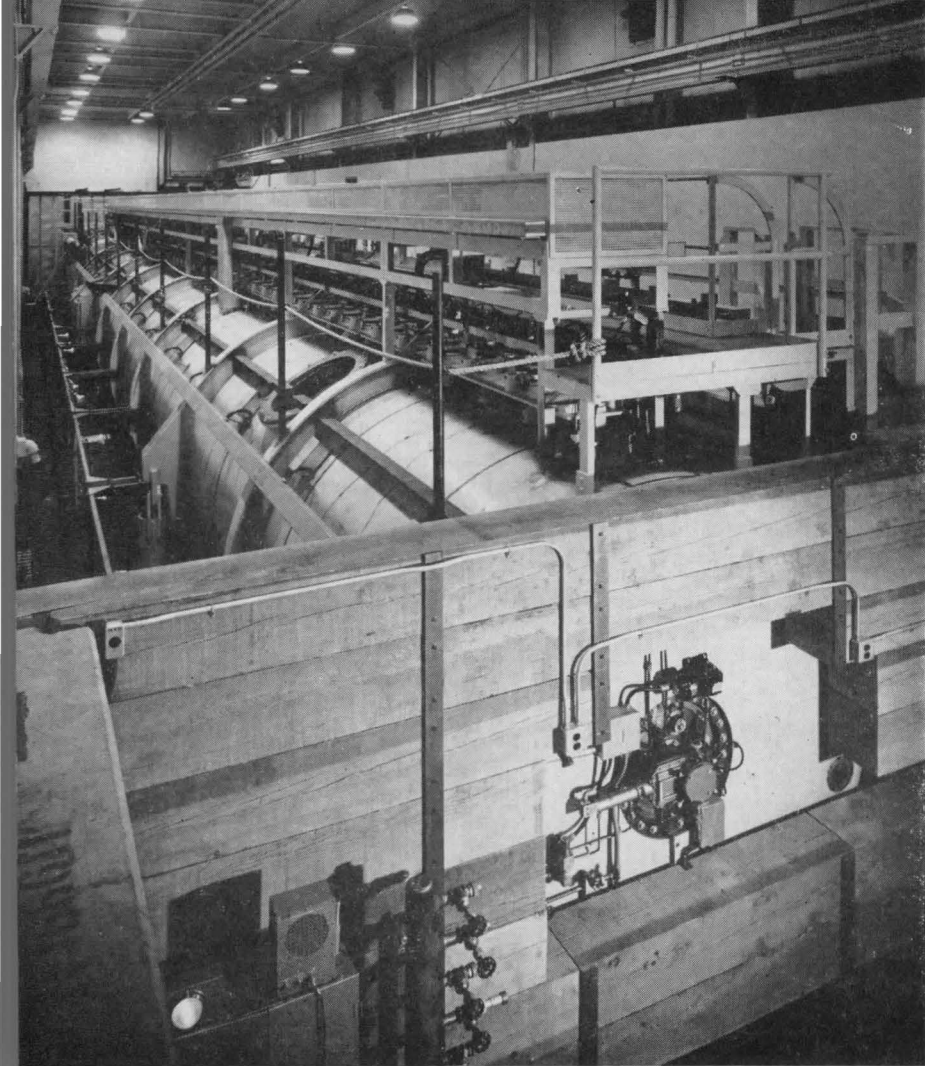



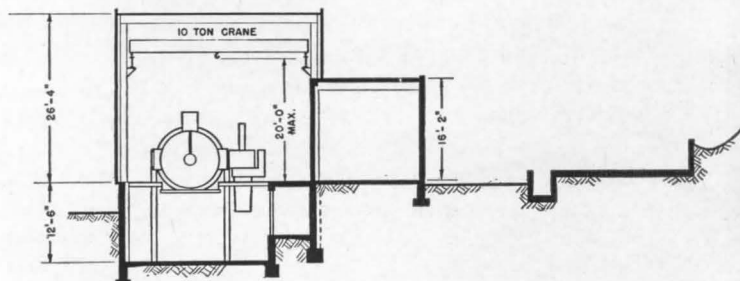

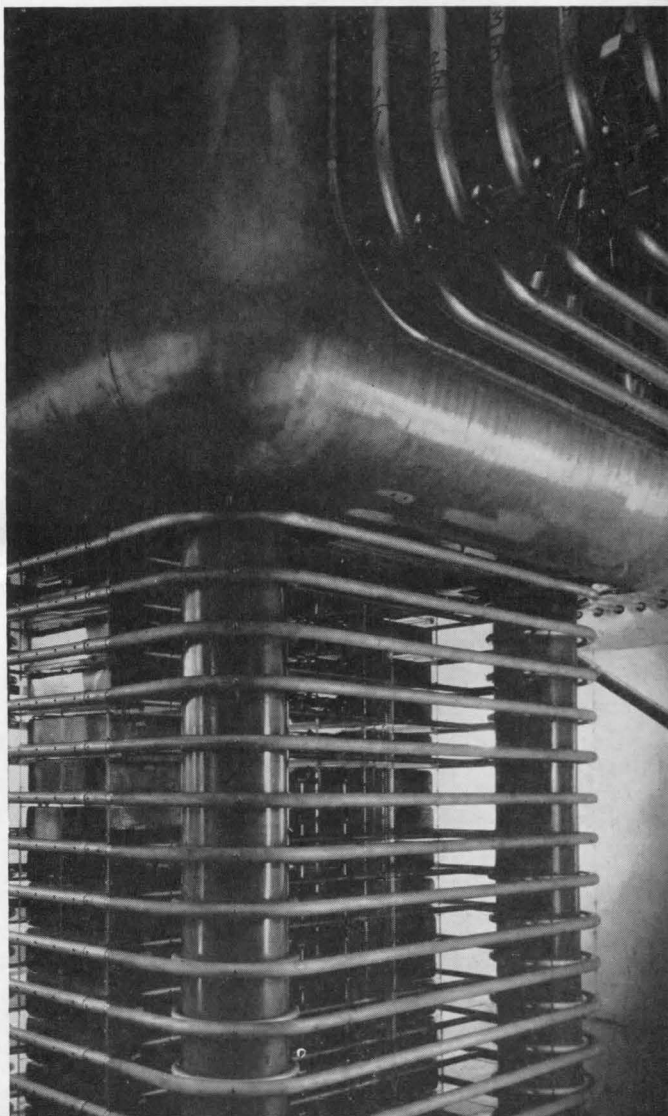

*From center of machine's "useful" end, beam of fast-moving particles will emerge, directed to target containing thin film of element to be bombarded. Heavy timber shielding around beam opening absorbs slow neutrons, strongly radioactive uncharged particles. Control room (top, right) is center of all electronic equipment for machine and building. Lead glass window looks to injector room. Concrete wall, 8 ft high, 2 ft thick, protects corridor (center) from radiation. Steel plate shields at far end. Doors lead to chemistry lab and counting room where transmuted elements are analysed, and to power rooms. Floors are concrete or, near machine, steel grating; roof is steel deck. Aluminum-sheathed Cockcroft-Walton voltage multiplier acts also as ion source, injector; supplies power for arc to "strip" heavy element atoms of some of their electrons, making ions, then gives initial acceleration*



SECTION A-A

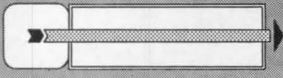
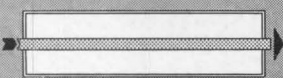
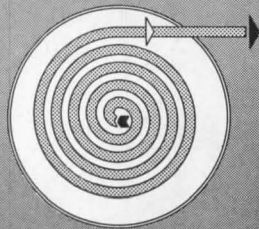
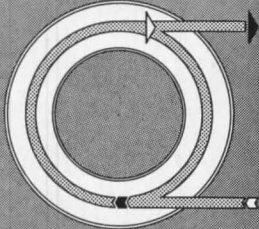

# ACCELERATOR TYPES

 Particle source  Particle beam  Target  Alternate target  Vacuum chamber  High voltage terminal	Particles accelerated	Accelerating force	Guiding force	
	<b>VAN DE GRAAFF</b>	Any charged particle	Electric (Static generator)	Electric
	<b>COCKROFT-WALTON</b>	Any charged particle	Electric (Voltage multiplier)	Electric
	<b>ELECTRON LINEAR ACCELERATOR</b>	Electrons	Electric	None
	<b>PROTON LINEAR ACCELERATOR</b>	Protons	Electric	Electric
	<b>HEAVY ION LINEAR ACCELERATOR</b>	Heavy ions	Electric	Electric or Magnetic
	<b>CYCLOTRON</b>	Protons Deuterons Alpha particles	Electric	Magnetic
	<b>SYNCHROCYCLOTRON</b>	Protons Deuterons Alpha particles	Electric (Frequency modulated)	Magnetic
	<b>BETATRON</b>	Electrons	Magnetic	Magnetic
	<b>ELECTRON SYNCHROTRON</b>	Electrons	Electric	Magnetic
	<b>PROTON SYNCHROTRON</b>	Protons	Electric	Magnetic

Types of accelerators vary with particle to be accelerated and use of resulting beam. Size also varies, depending on energies needed for specific research. All types shown above are used in basic research, but Van de Graaff, linear and betatron accelerators are valuable in industry as well. Cockcroft-Walton and Van de Graaff are used either alone or as injectors, providing initial acceleration of particles for large machines like Berkeley Bevatron and Brookhaven Cosmotron which need particles already accelerated. Energy acquired by charged particles passing through electrical field is proportional to potential difference. In most circular machines (cyclotron, betatron, etc.) magnetic field is used to keep particles moving in circular path; linear accelerator uses alternating high frequency and free fields, usually has no magnet as particles normally move in straight line, producing concentrated beam

## THE DESIGN OF PARTICLE ACCELERATOR BUILDINGS

By WILLIAM MAXWELL RICE, A.I.A.,  
University of California Radiation Laboratory,  
and Member, Committee on Nuclear Facilities, A.I.A.

and ELISABETH KENDALL THOMPSON,  
Senior Associate Editor, ARCHITECTURAL RECORD

A MACHINE that can be operated to produce new elements, that can break up elements once thought indivisible and so probe that secret treasure-house of life itself, the nucleus, must inevitably be regarded as a thing of awe and mystery. For the layman, that is what the accelerator is, and indeed, a machine that can cause invisible bits of matter to course along its path at a rate of speed almost equal to that basic module of the universe, the speed of light, is an awesome thing.

In this nuclear world the architect, too, is a layman and so may be excused if in his wonder at the news of discovery of element after element, of unsuspected isotopes of new elements, or of the splintering off of new nuclear particles, he sometimes tends to impart to the buildings for these machines something of the awe he accords to the processes they make possible. Mesons, neutrinos, antimatter may confound him, but the reality of concrete and steel, brick and tile and the good earth, should reassure him.

For amazing as are the results obtainable with accelerators, and portentous as is the horizon which these machines open up, the buildings in which their work goes on are neither amazing nor awesome, nor is their design beyond the scope of today's architect — provided he is willing not only to inform himself on the building's special requirements but to acquaint himself



*Bevatron, University of California Radiation Laboratory, Berkeley, a proton synchrotron producing energies up to 6.6 billion electron volts (hence name) is still world's largest operating accelerator. Building illustrates basic elements of design requirements in this field: space for machine and equipment using "beam"; generators; massive shielding (5 ft concrete blocks, stacked 15 ft high); "maze" entrance; multiple target areas; control and counting rooms; detecting equipment (cloud chamber or new "walking" bubble chamber for photographing particle tracks). Masten and Hurd, architects for original building; Milton Pflueger, architect for addition and bubble chamber building*

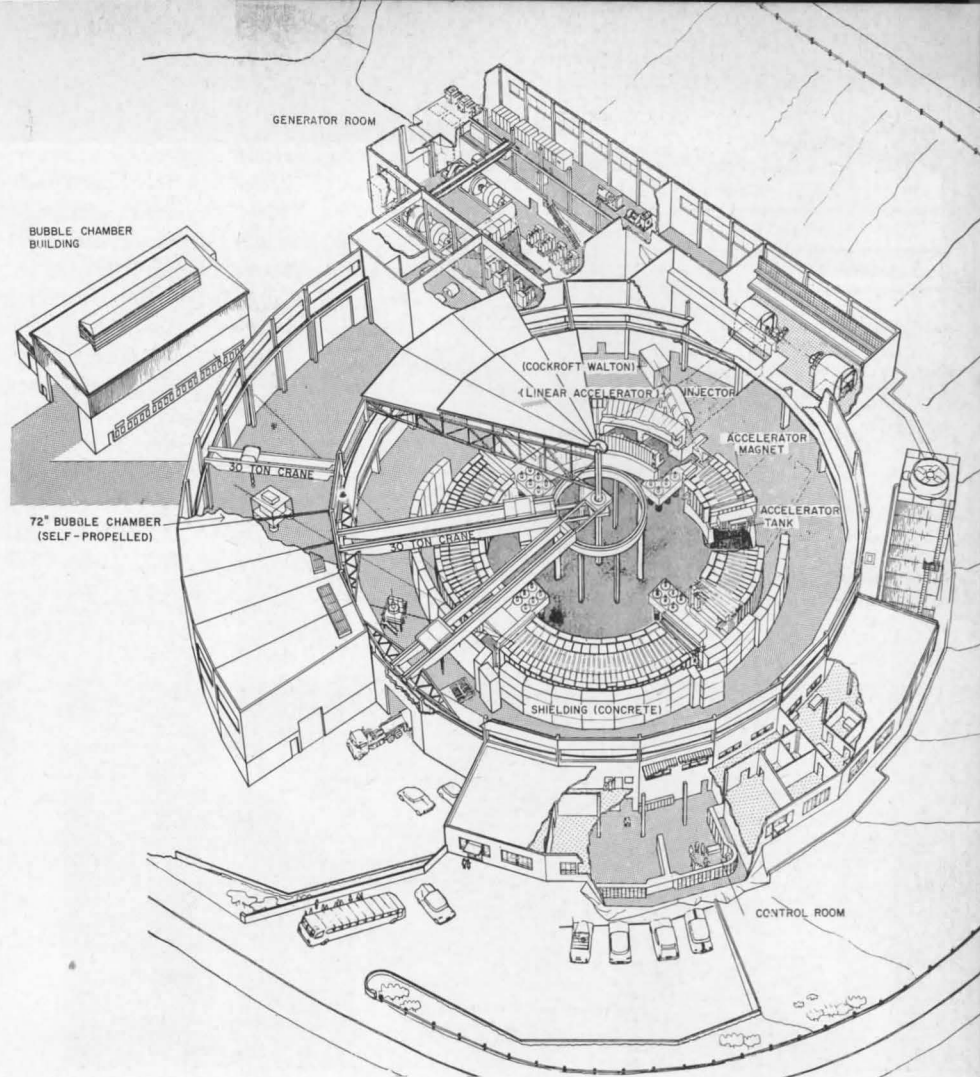

fully and analytically with the needs and means, the wants and hopes, of the scientists and engineers who will operate the machine. The basic architectural premises — that a plan must function well, that a building should express its purpose, that its design is founded on the age-old truths of proportion, harmony, form and the rest — need to be applied with deep and very real understanding of the scientist's infinite curiosity and the intricate and highly imaginative ways in which he seeks to satisfy it, opening up as he does so the boundaries of knowledge for further exploration.

The majority of the mammoth machines in which the incredible becomes almost an everyday commonplace are located at universities or at research installations operated for the U. S. Atomic Energy Commission. The size and cost of these machines make it unlikely that very many of them or their buildings will be built; this kind of building will be an infrequent project for the architect. He will find, however, that accelerators are increasingly being applied to industrial processing, and for that reason he should know the basic principles of their design. Although the machines used in industry are a great deal smaller than those at national research laboratories, the essentials of architectural design are much the same in both, varying more in size and in number of facilities than in kind.

In most buildings housing machines there are people — stationary, moving or intermittently present, and it is rare that these buildings are designed without human activities, motions and requirements as the module. The machine as we have known it has been a gregarious part of a moving, human scene. But the accelerator, by the very nature of the processes that go on within it and the products that emerge from it, is a lonely performer. Massive shielding must envelop it; human beings must avoid the radiation from it when it "works." No hands will touch it to adjust a valve while it is operating. Safely shielded from it, in an enclosed room, an operator will control every part of its action, and when it has completed its function, the results of its "work" will often be but a small amount of matter which, in all probability, no one will ever be able to see. Nevertheless, the human element is still a part of these buildings, though in a new and different equation which must be solved in a new and different way.

The paradox of so large a machine laboring to produce so infinitesimal a result, and of human beings, the most complex machines of all, depending on an electronic device to detect for them the precious bit of matter which their eyes cannot see and their hands dare not touch, has its parallel in the architectural world. For architecture is an art, but it is useful or it is not

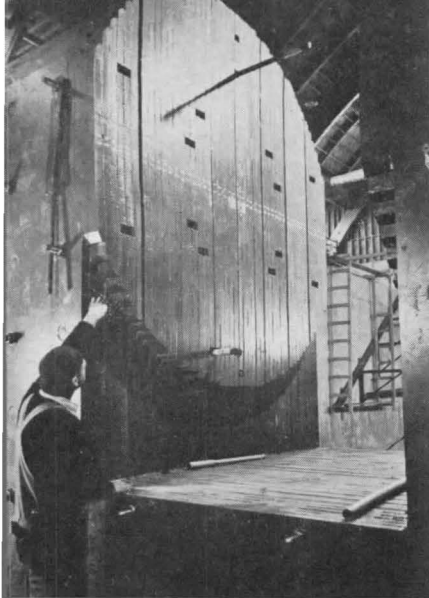

1 90-in. Cyclotron, UCRL (Livermore)

1. Cyclotron is "classic" particle accelerator of type based on use of electromagnetic circular field and repeated electrical "kick" at each revolution. Most are horizontal; vertical mount increases beam use. 2. Cockcroft-Wallton is voltage-multiplier, ion source, accelerator; also used as injector for larger machines. 3, 4. Van de Graaff is modern version of classic static generator, useful in research and industry. Steel tank keeps machine under pressure. 5. Synchrocyclotron is like cyclotron but uses frequency modulation as compensation for particles' increase in mass. 6. Linear accelerator produces high intensity beam useful in research and industry. 7. Synchrotron uses only ring magnet, is basis for newest, largest accelerators like Cosmotron (8), Bevatron, p. 187, A. G. S. at Brookhaven, p. 190

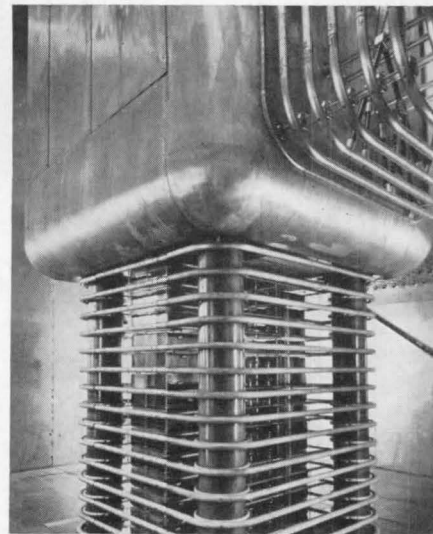

2 Hilac, UCRL (Berkeley)

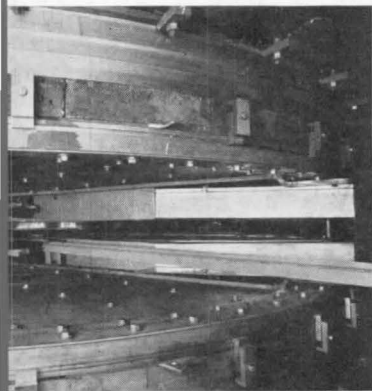

5 Synchrocyclotron, UCRL (Berkeley)

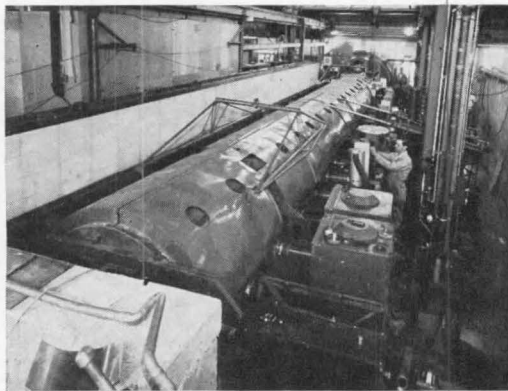

6 Linac, UCRL (Berkeley)

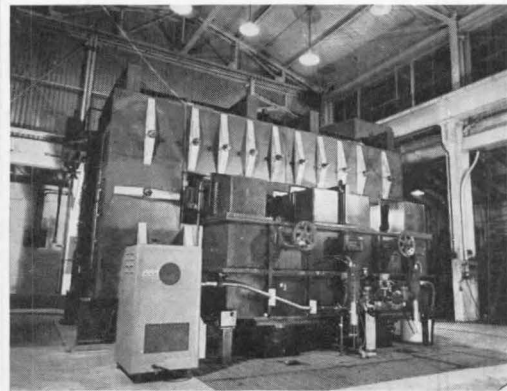

7 Synchrotron, UCRL (Berkeley)

architecture; and without people to use its buildings, they become only empty shells.

#### What is an Accelerator?

When the first cyclotron was built it was popularly known as an "atom smasher," and though the term is not exactly correct in its connotation, it will give identity to the accelerator, for the cyclotron is one kind of accelerator. Like other machines, accelerators are of different sizes and shapes, depending on the kind of particle which they are to accelerate, but their common purpose is to impart literally astronomical speed to charged particles so that they will acquire sufficient energy to penetrate the atomic structure of an element and break it up into its components. When the particles have acquired enough energy, they are ejected as a "beam" — usually not visible, though sometimes one can be seen — which is directed toward a metal target plate on which is a thin film of the element to be "bombarded" (not "smashed") by the particles. What happens then cannot be seen by the eye, but the collisions ("stars" and "events") which take place can be graphically recorded by various means: the photographic emulsion, the cloud chamber, or the newest, the bubble chamber. These give pictures of the paths of the charged particles that have passed through these detectors.

Electric signals picked up by the "counters" also evidence the effect of the beam on the target, or vice versa.

In the multiplicity of parts, in the electrical and mechanical services which it requires, the accelerator is a complex machine; but its operating principles are simple. Charged particles — electrons, protons, alpha particles, deuterons or other ions of heavier elements — travel at high velocities along a predetermined path through alternate regions of free and high frequency fields in a vacuum chamber, and are kept on this path by either an electric or a magnetic field. As the particle passes from the field-free region (in a linear accelerator this is in the "drift tube") to the high field region ("crosses the gap") it receives an accelerating "kick." (In betatrons acceleration is by electromotive force induced by a changing magnetic field in a ring-shaped vacuum tube.)

$$E = mc^2$$

The faster the particles move, the greater the energy they build up. The largest machines today are proton synchrotrons which are used to produce both "new particles," like mesons, antiprotons and antineutrons, and beams of protons in greater quantity and purer composition than those obtainable in cosmic rays. The

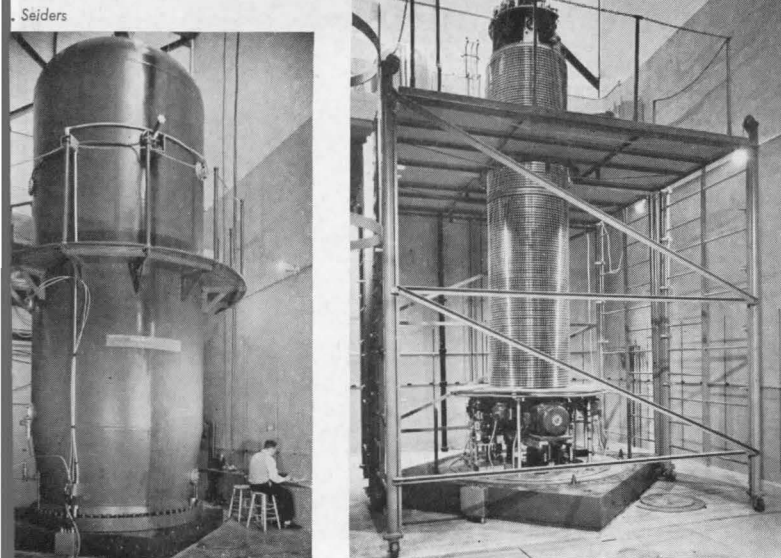

3, 4 Rice Institute High Voltage Laboratory

Stiles & Associates

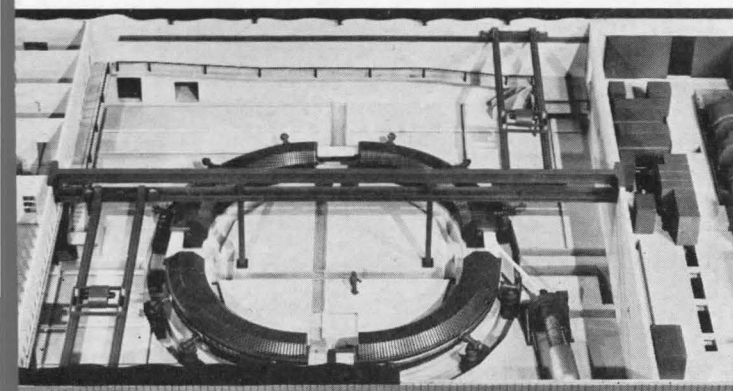

8 Brookhaven National Laboratory

6.6 Bev \* Bevatron at the University of California Laboratory is the largest currently operating. But larger machines are being built or are in the plan stage. A 10 Bev accelerator of the Bevatron type is being completed in Russia; C.E.R.N. (European Council for Nuclear Research) in Switzerland and Brookhaven National Laboratory in New York are building 25 Bev accelerators, of an entirely new type called the alternating gradient synchrotron; and the Midwest Universities Research Association is planning an even larger one. The size of these machines is relative only to the energy that can be built up during acceleration; if the same energy can be got from a shorter path, the future will be in that direction; if it cannot, linear accelerators will get longer and longer (Stanford University has talked of a two-mile one), and circular ones will have ever greater diameters.

#### Protection From Invisible Radiation

These high velocities and consequent high energies are not, however, without their price. The radiation which emanates from the highly energized particles constitutes what is probably the single most awe-inspiring aspect of the accelerator building. For this radiation is a hazard

\* Billion electron volts; an electron volt is the energy acquired by an electron — or proton — as it goes through a one-volt potential difference.

Stiles & Associates

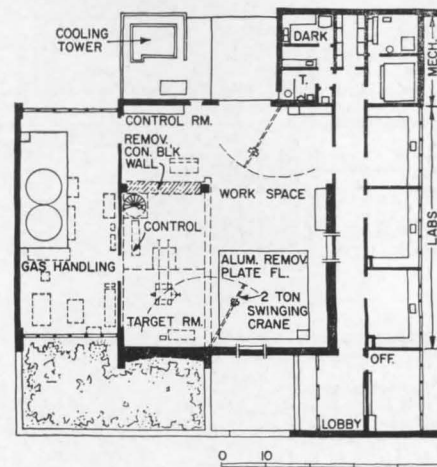
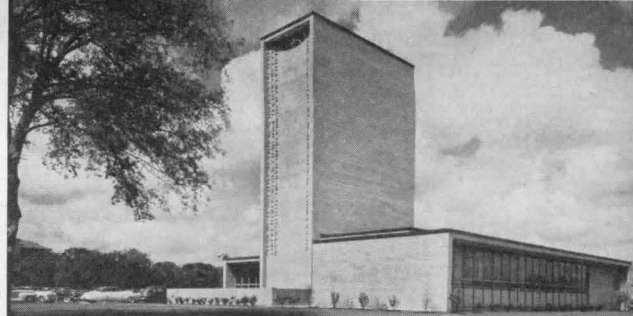

HIGH VOLTAGE LABORATORY, RICE INSTITUTE, HOUSTON, TEXAS. GEORGE F. PIERCE AND ABEL B. PIERCE, ARCHITECTS. Tower height was determined by height of 5.5 Mev Van de Graaff plus its steel tank cover, removable for access to machine. Walls act as shielding to second floor level. Brick finish is campus tradition

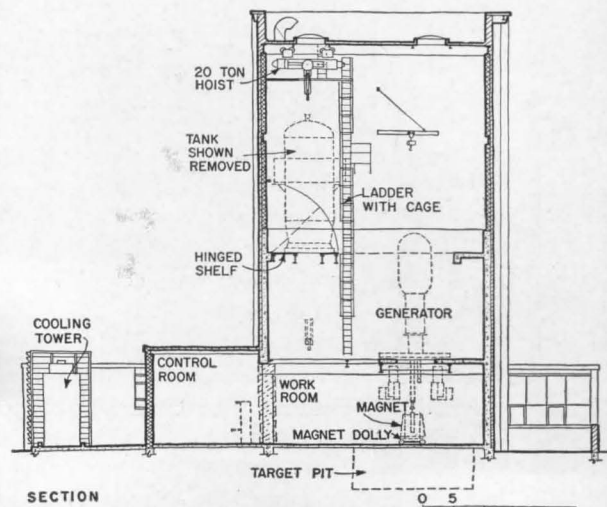

Stiles & Associates

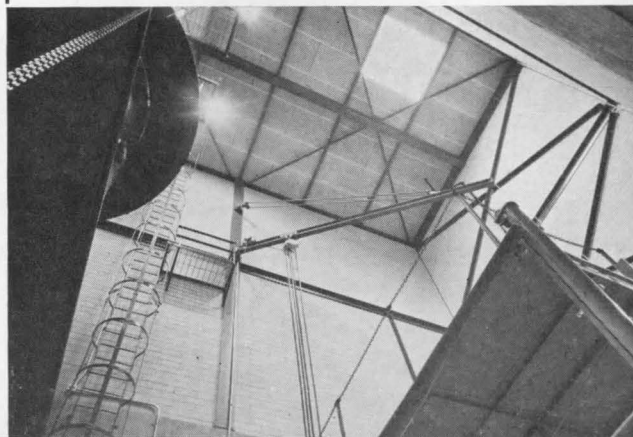

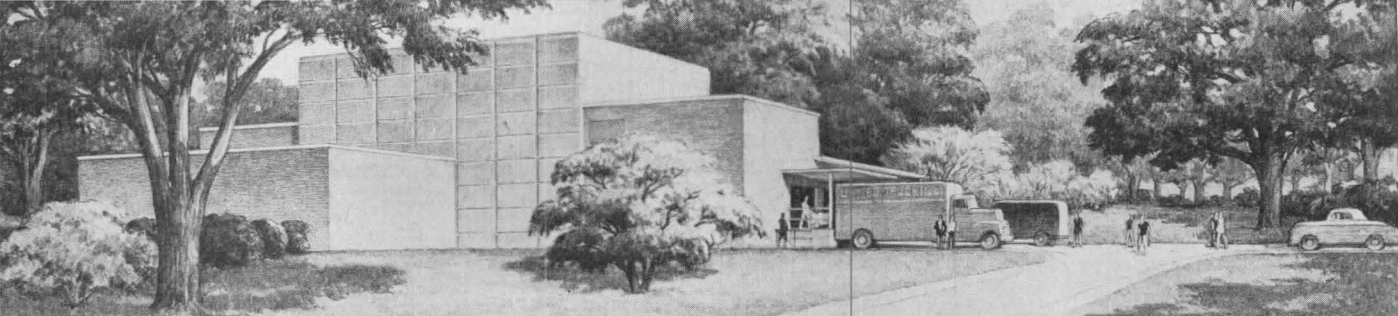

Chester B. Price

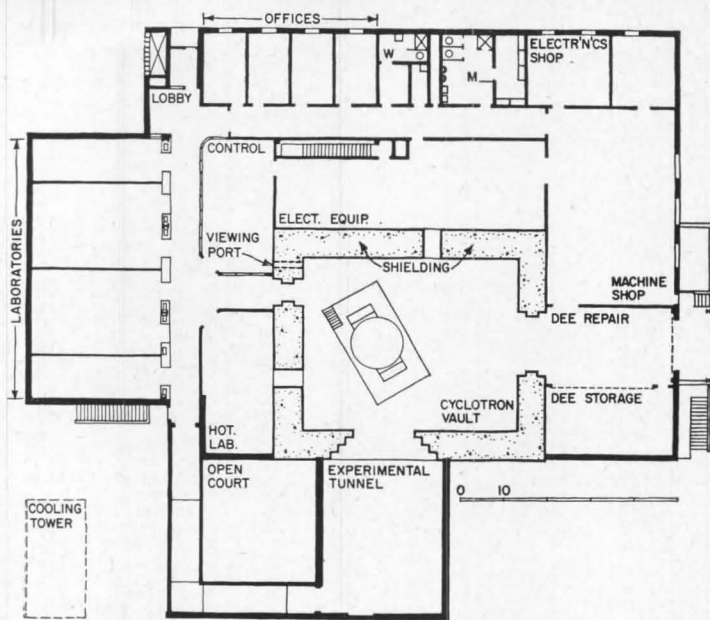

**CYCLOTRON BUILDING, ARGONNE NATIONAL LABORATORY, LEMONT, ILL. VOORHEES, WALKER, SMITH & SMITH, ARCHITECTS.** Argonne's cyclotron building is based on concept of shielding permanently in place and acting as part of structure (in contrast to flexibility of movable panels). Concrete walls 7-ft thick, ceiling 4-ft thick, floor, 18 in. thick, completely enclose cyclotron. Tunnel for experiments, in direct line of beam from machine, opens off cyclotron room and connects with laboratories so equipment can be moved in easily. Knockout panel on outside wall of tunnel, centered on beam's center line, will permit expansion if necessary. Thick window and "viewing port" provide visual connection between cyclotron room and adjoining control room and "hot" laboratory

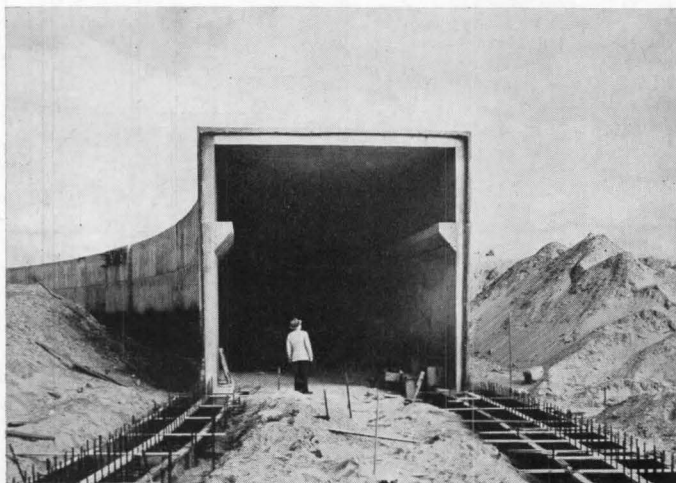

**ALTERNATING GRADIENT SYNCHROTRON, BROOKHAVEN NATIONAL LABORATORY, UPTON, NEW YORK. STONE AND WEBSTER ENGINEERING CORPORATION, ENGINEERS.** This newest type of accelerator will accelerate protons to at least 25 Bev — a higher velocity than has been possible before — in an annular magnet of unusually small cross section. Using alternate strongly converging and diverging magnetic fields, it will keep protons in a narrow track housed in a circular subterranean tunnel, 17 ft high by 18 ft wide, one half mile in circumference. Length of this track as well as design of the accelerator itself account for the expected high velocities and consequent energies to be produced in the particles. These tremendous energies will require unprecedented shielding; burying the magnet is an economical and effective way of providing this protection. Linear accelerator injector and target are in their own buildings outside magnet ring. With such a concept, architecture is implicit only in target and linac buildings and in site planning, but its impact could nevertheless be important

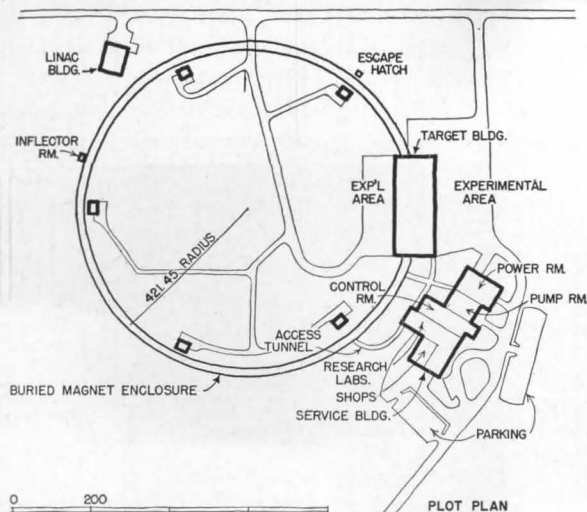

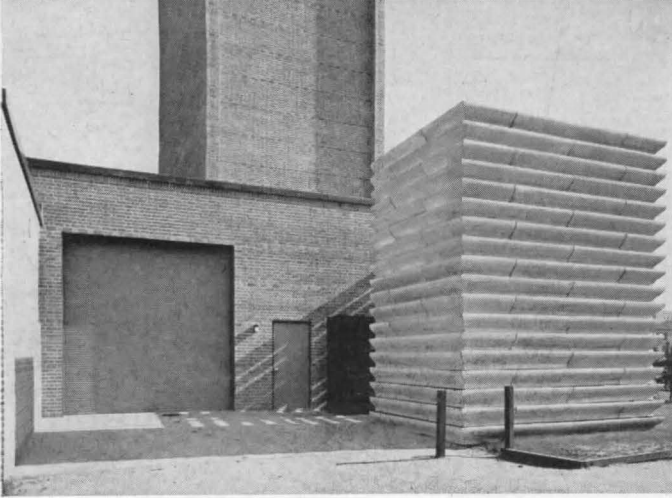

Stiles & Associates

1

**SPECIAL NEEDS IN ACCELERATOR BUILDINGS** 1. *Cooling Towers: Magnets, with tremendous heat-producing coils, must be cooled by continually circulating non-conductive water (or by air). (Rice Institute cooling tower.)* 2. *Power Supply: Large amounts of electricity for generators, vacuum system, pumps, etc., imply early collaboration between architect, electrical engineer is essential to design solution. (Hilac pulse forming line.)* 3. *Shielding: Mass, density, distance are three main ways to protect from dangerous radiation around machine during operation. Suitable materials: concrete, lead, steel, earth, water, sand. (U.C.R.L. Synchrocyclotron.)* 4. *Space for Equipment: Biggest problem is providing enough space economically for machine and required research equipment. Analysing magnets, channels, inflector are just part of equipment needed to inject Cosmotron with protons generated by Van de Graaff at Brookhaven National Laboratory*

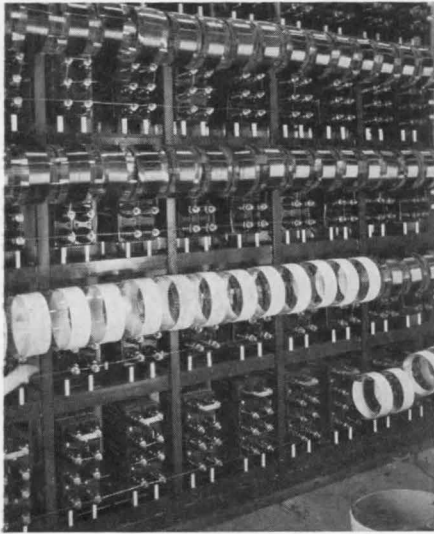

2 UCRL (Berkeley)

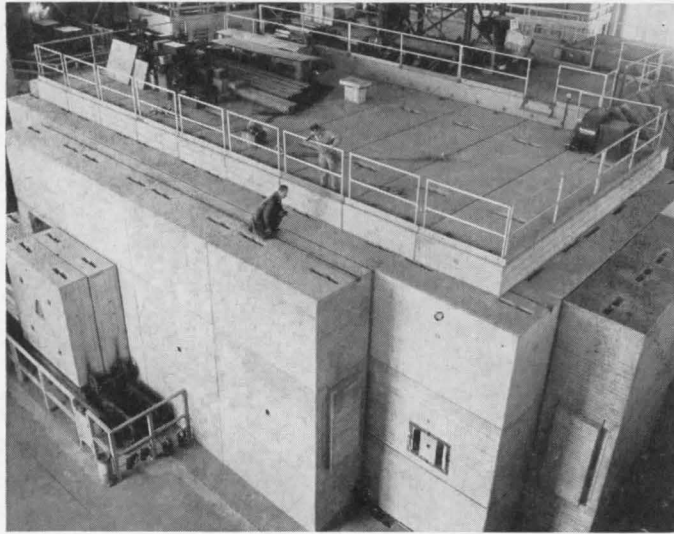

3



4

of the first order and being invisible and cumulative, it is insidious. But it is far from being an unknown and unknowable hazard. Protection against it is not only possible in a variety of ways but is simple to effect. Accelerators, in this regard, have a distinct advantage over other nuclear machines: radiation stops when the machine is shut down.

Basically, all radiation is the release of energy, but some kinds of radiation are dangerous. All produce their effects through ionization—that is, normally neutral atoms are shorn by this released energy of one or more of their electrons and become unbalanced, a state in which they are called ions. Alpha particles (the nucleus of the helium atom) are too weak to penetrate deeply, but have strong ionizing abilities and are especially dangerous if inhaled or otherwise taken into the body. Beta particles are electrons; they penetrate deeper into living tissue than alpha particles but, like alphas, can be effectively stopped by a layer of clothing. In sufficient concentration, however, they can cause bad burns. Gamma rays are not particles; they are similar to X-rays and penetrate deeply, causing internal burns, illness and, with sufficient exposure, death.

Protection against these radiations is afforded, first of all, by distance, but the impracticality of relying

solely on this as a method of protection is obvious. Nevertheless, it has its place in the planning of a nuclear facility. The practical solution lies, for the present, at least, in more tangible means: the provision of barriers of sufficient density to stop the energetic particles in their precipitate tracks before they reach the area where they might do harm to living things.

For effectiveness, availability and relative inexpensiveness, the most universally used shielding material is concrete, either the ordinary 150-lb variety or the denser 200-lb "heavy" concrete with iron ore, steel scrap or barite aggregate, useful where beam intensity is particularly great. Water, earth and sand are less expensive but require greater bulk; lead and steel take up little space but are expensive. What material, how much and where it shall go are decided by the health physicist, health chemist (two new "watchdog" professions) and the scientists who will use the machine, on the basis of human occupancy of nearby areas.\*

If the scientist were to be asked what he most wants in an accelerator building, he would probably say "Plenty of space that I can use in many ways." What

\* Shielding in industrial and commercial installations is subject to regulation in some states. Research installations are usually exempt provided they meet certain standards of control and monitoring. Bureau of Standards Handbooks 50, 55 and 60 give design recommendations for protection against radiation hazards.

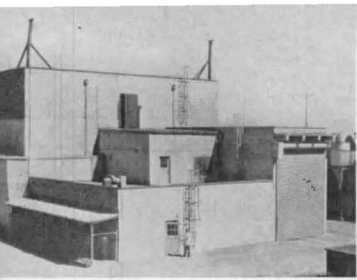

1

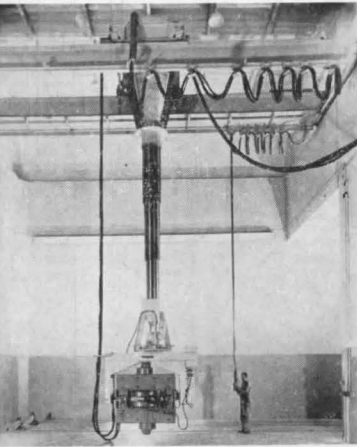

2

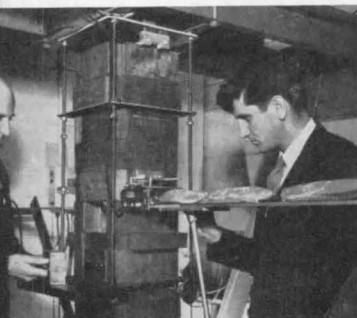

3 General Electric Company

Allis-Chalmers Company Radiation Laboratory

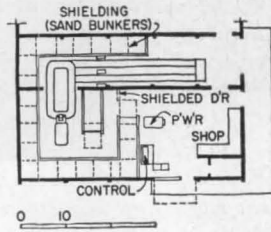

5 Applied Radiation Corp., W. M. Rice, arch.

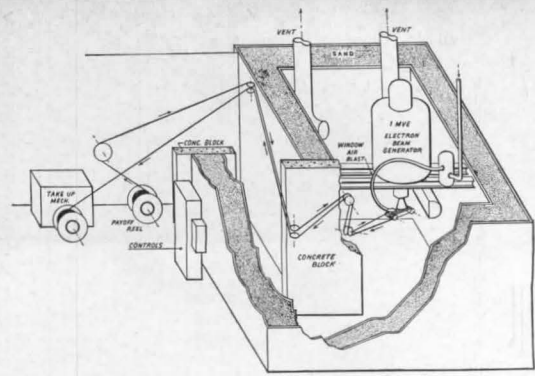

6 Sequoia Process Corporation

**ACCELERATORS AT WORK IN THE PEACEFUL WORLD** 1. Betatron detects flaws in machine parts, is basic industrial research tool. Allis-Chalmers lab is model installation, offers custom radiography. Crane in shielded bay (2), telescoping tube make machine's use flexible. Used medically, betatron is valuable cancer therapy aid. 3, 4. Food irradiation, still in research stage, has huge potential. 5. Small industrial installations are on increase: Applied Radiation Corp. plan shows conveyor belt for product irradiation (W. M. Rice, arch.), uses inexpensive sand shielding as does Sequoia Process Corp. (6) in irradiating plastic covering for electric cable. 7, 8. Industry's concern for radiation protection is evident in Varian Associates' 5-ft concrete plug door operated on monorail, and sunken linac pit (Michael A. Gallis, arch.)

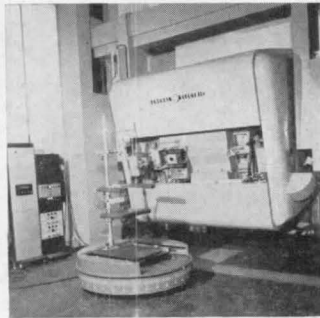

4 U of C Medical Center, San Francisco

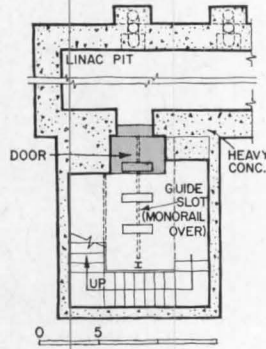

7, 8 Varian Assoc., Michael Gallis, arch.

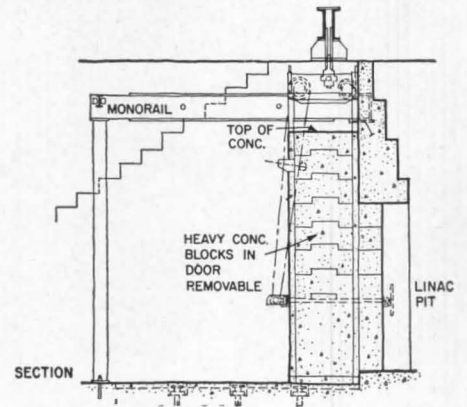

those ways are he probably cannot say even during programming, but what he means is that the space for research in the building should be as big as the budget will allow, and as flexible in its use as the architect can make it. Change is the essence of research, and the ideal building, like the true scientist's mind, will be ready to accommodate anything that may happen in an experiment.

In a very real sense, however, the machine is the real determinant in the building concept, not as a machine but as a means by which an idea becomes reality. Without the machine, the experiment is only a hope and the idea but a formula. But the machine alone is not enough. Large as it may loom in the scientist's mind as the major item in the budget for the project, and undeniably important as it is, the machine without certain supporting facilities could not function to an over-all useful purpose.

The laboratories, so located that the chemical characteristics of the few atoms of a newly made element can be analysed with a minimum of delay; the counting rooms where electronic detectors verify the physical presence of invisible atoms—even before chemical analysis is made—and give the quantitative and qualitative data that are stepping stones to the future; control rooms, power supply rooms, technicians' shops,

cooling towers—these are all essential elements in the building's program.

The challenge to the architect lies only partially in analyzing the use of these various supporting facilities and resolving the relationships between them and the machine so that the parts, functioning as a whole, contribute subtly to the performance of each experiment. The further challenge lies in shaping an environment which is of, in and around the building and which will eloquently state, to those who use it and to those who only see it, that the purposes of science and the benefit of mankind are, in a peaceful world, inextricably linked.

What has been said of the research building has particular significance in the fields of commerce and industry, where the potential opportunity for the architect is greatest. If that potential is to be realized—as it could be—he will have to remind himself that "imagination without learning is like having wings and no feet." But clients—scientists, engineers, industrialists—must also remember this. If the architect's wings are sometimes bigger than his feet, the client's feet are often bigger than his wings.

Knowledge and imagination together were the source of the nuclear age. They both belong to its architectural interpretation.



All photos by Currie—CINVA, except as noted

## INTER-AMERICAN HOUSING CENTER

Bogotá, Colombia

*The Inter-American Housing Center (CINVA), a technical assistance project of the Organization of American States, was established in 1951. It is, we understand, the first institution in the world dedicated specifically to training, research, publications and consulting service in the housing field. Graduate students come from the 20 Latin American republics, from Puerto Rico and occasionally from other countries. The building was designed by the Center's staff, including Leonard J. Currie, A.I.A. (former Director of the Center, who acted as job captain), Guillermo de Roux of Panama (design), Celestino Sanudo of Chile (preliminaries), Herbert Ritter and Eduardo Mejia of Colombia (drawings and specifications). Engineers: Carlos Valencia and Jorge Arias de Greiff of Colombia; landscape design, Leonard J. Currie; builders, A. Manrique e Hijos, Manuel J. Uribe C., of Colombia. The description that follows was written by Mr. Currie*

## INTER-AMERICAN HOUSING CENTER

IN THE DESIGN of the building for the Inter-American Housing Center (CINVA) there were no problems. The architects created none. One might think that, in approaching the design of a building for a unique and international function, the loose association of architects from different countries and cultures might have settled for the latest interpretation of the international style, the all-glass curtain wall, or possibly for some of the more national expressions with novel, large-scale plastic forms.

It is perhaps indicative of the maturity, self-assurance, and reasonableness of thought that has become the common norm of CINVA that everyone agreed from the outset upon a desirable character for a building to house an institution that advocates

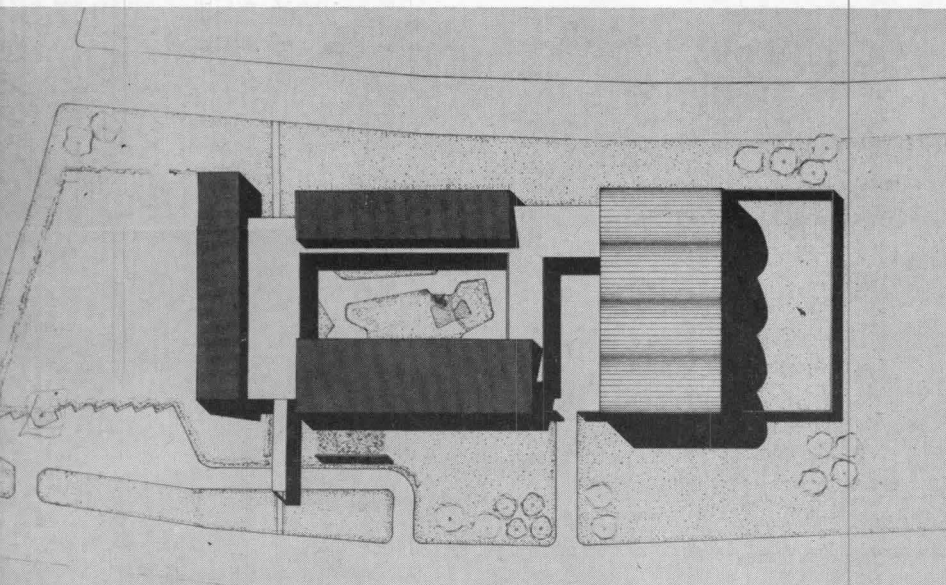
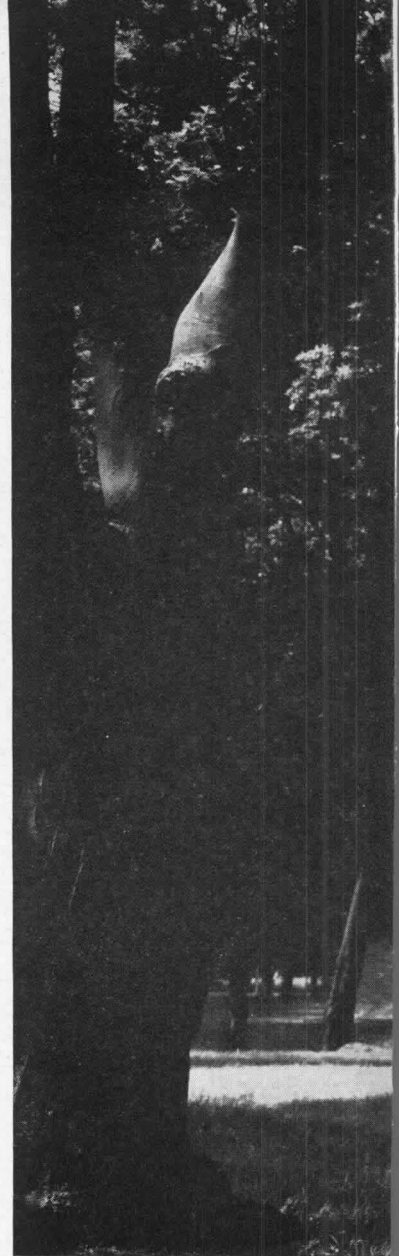
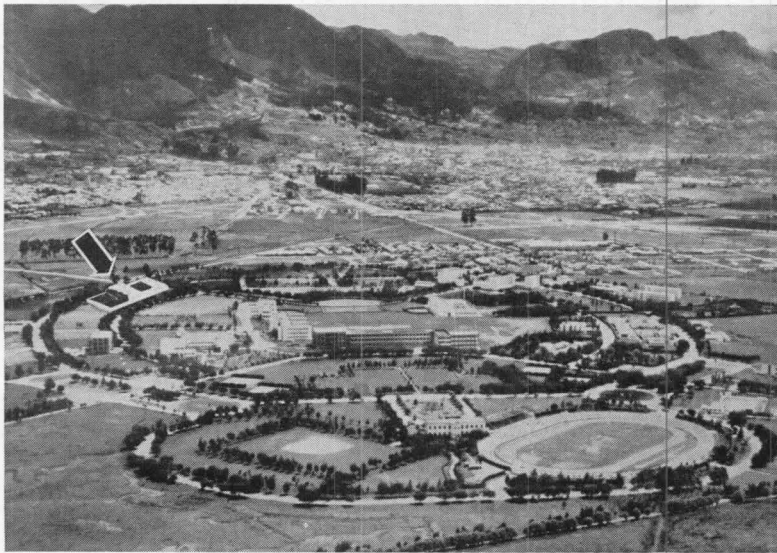

- |                   |                        |
|-------------------|------------------------|
| 1. Entrance       | 16. Cataloging         |
| 2. Exhibition     | 17. Librarian          |
| 3. Reception      | 18. Microfilm          |
| 4. Director       | 19. Printing shop      |
| 5. Office         | 20. Lecture            |
| 6. Secretary      | 21. Conference         |
| 7. Administration | 22. Drafting           |
| 8. Registrar      | 23. Photo laboratory   |
| 9. Lockers        | 24. Restroom           |
| 10. Restroom      | 25. Watchman           |
| 11. Storage       | 26. Construction lab.  |
| 12. Restroom      | 27. Patio              |
| 13. Storage       | 28. Garage             |
| 14. Kitchen       | 29. Service            |
| 15. Library       | 30. Experimental patio |





Currie—CINVA

*View from the north; wall encloses the experimental patio; thin-shell vaults of sprayed-on concrete roof the construction laboratory, making possible a room 66 by 120 ft without interior columns. Across page, air view of National University campus showing location of Housing Center*

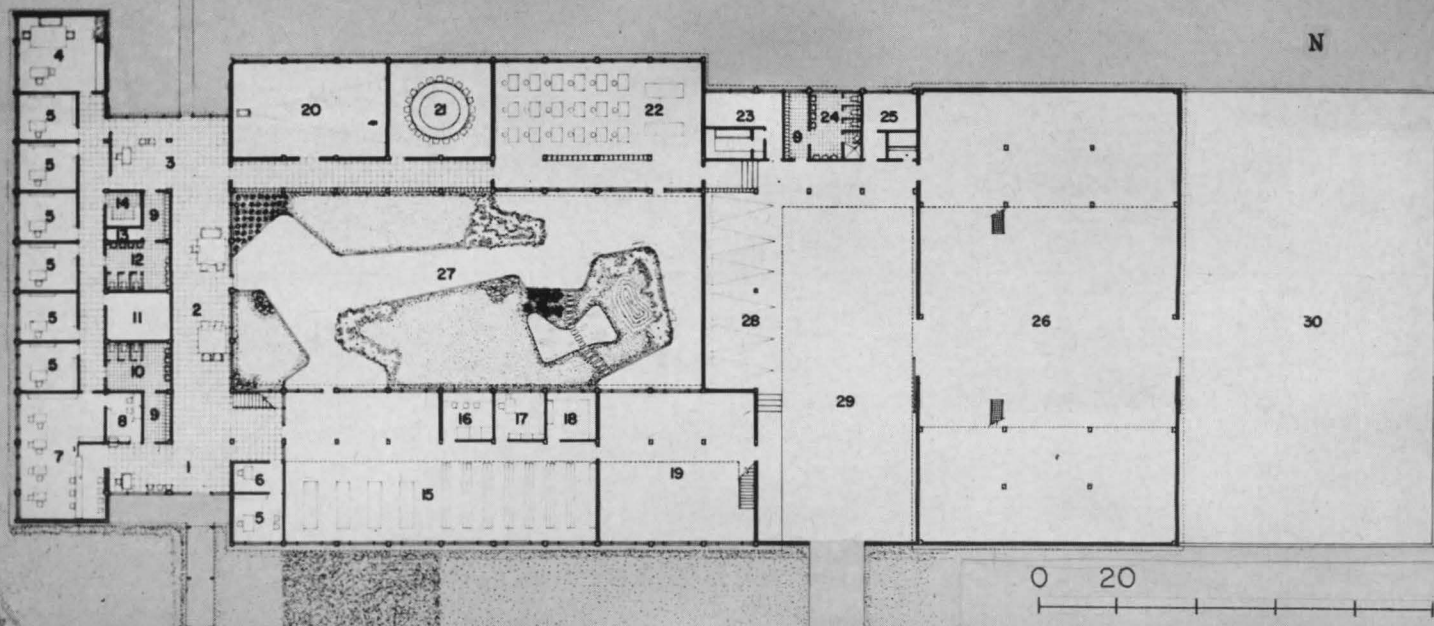

## INTER-AMERICAN HOUSING CENTER

simple, thoughtful, economical, durable solutions to problems of low-cost housing. It was understood from the beginning that there would be no striving for monumentality in either the pre-Giedion or post-Giedion sense of the word; that no design clichés would be permitted; that the building form would be simply determined by functional requirements, available materials and established building techniques, site and climate, convenience and non-assertive harmony.

Although much of CINVA's approach to housing is expressed in the architecture of its building, it should not be assumed that the forms that have evolved are those advocated by CINVA in the solution of specific housing problems. In truth CINVA, to the disappointment of those who seek ready-made solutions, has come forth with no pat architectural formulae for housing legislation, for financing, or for community organization. Rather, CINVA tries through its training program and its publications to develop a methodology out of which essentially local solutions result, forms that grow out of local traditions, local cultural patterns, local materials, and local climate.

The enclosing of a series of patios in conformity with Colombian Spanish Colonial tradition is not arbitrary romanticism, but rather a recognition of factors of climate and social problems that have changed little since Colonial times. The garden patio is a sheltered place to catch the limited sun of overly cool Bogotá. It is still prudent in Colombia to protect the service and experimental patios with high enclosing walls.

Although the site is only four degrees from the equator, the 8600-foot altitude of Bogotá places it in what is characterized as *clima fria* (cold climate), a region in which the sun is welcome throughout the year from virtually all points of the compass. To capture all available sun, the Center was designed with ample windows and rather close eaves just sufficient to protect the walls and windows from rain. The entrance pergola and the open-but-

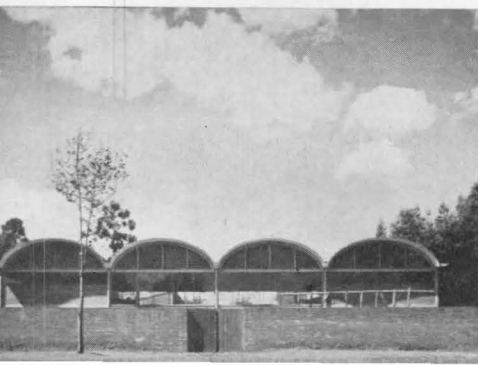
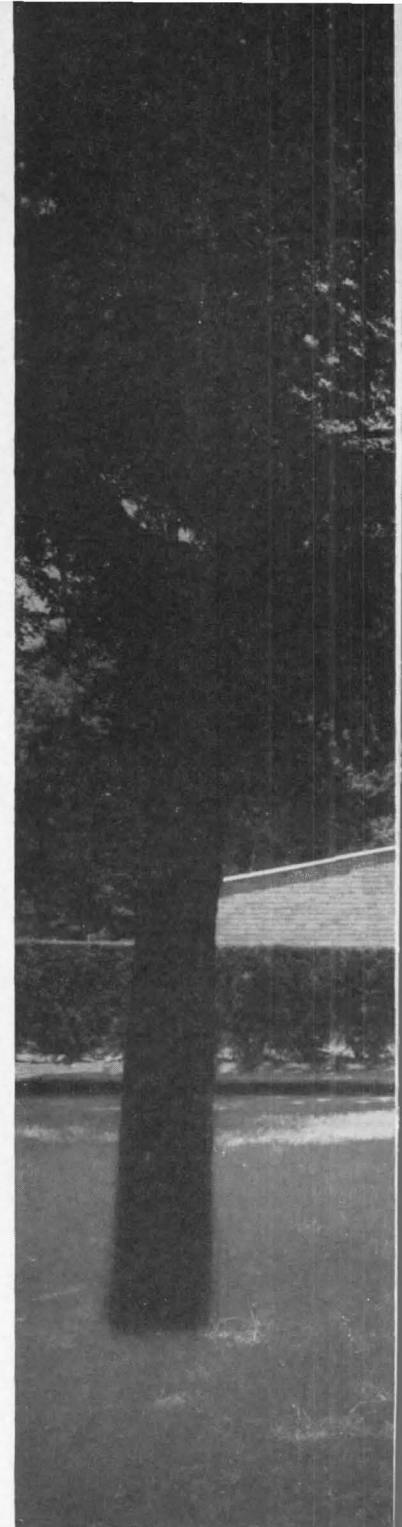



*Above, main entrance is from the east. Pergola built of guayacan (a hard tropical wood) and corrugated cement-asbestos sheet affords protection from heavy rains. Below, left to right, view from the north; west (secondary) entrance from students' dormitories; reception desk near office entrance; north entrance and exterior of library*

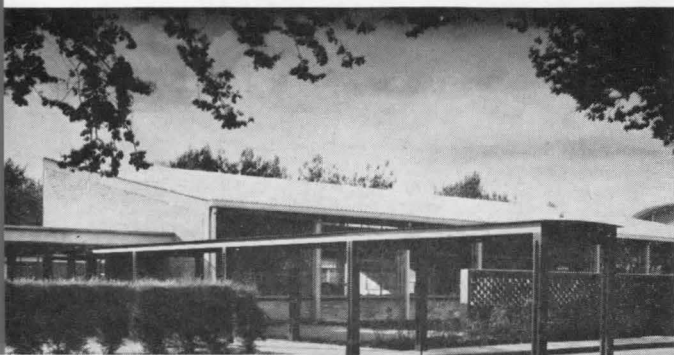

## INTER-AMERICAN HOUSING CENTER

covered connection to the construction laboratory exist because heavy downpours are frequent.

The site, on the campus of the National University, is of adequate size for the spread-out plan, which is essentially one-story with mezzanines in the library and construction laboratory. This permitted simple construction methods with a minimum of scaffolding or hoisting equipment. Since there is no central heating or air conditioning there is no compulsion for a compact plan.

Recognizing that roof leaks would be inevitable, the architects chose, wherever possible, simple monopitch roofs of corrugated cement-asbestos; with such roofs, leaks are less disastrous than with flat decks, and they are relatively easy to repair.

For over four centuries locally produced brick has been the predominant building material in Bogotá. In recent years the more pretentious buildings have had their brick walls clothed with stucco, paint, terrazzo, thin stone veneer, and even artificial stone imported from the United States. Needless to say, these cosmetic treatments increase initial costs and are calamitous from a maintenance viewpoint. With the knowledge that maintenance funds would be extremely limited, and faced with the example of the lack of maintenance of other buildings on the campus, CINVA's architects chose brick and glass for exterior walls, common clay tile for the floors, rough plaster interior walls, ceiling planks of wood fiber and cement. Exterior painting was limited to windows and doors.

The roof of the construction laboratory consists of four thin concrete shells, each spanning 30 ft by 66 ft, thus enclosing a space 66 ft by 120 ft without interior roof supports. This roof, a scant two inches of Gunitite concrete, proved economical to build in a situation where material costs are high (and savings in materials are therefore paramount) and labor costs are low. Of course the architects had an experimental as well as an esthetic interest in the thin-shell roof; however, its form and structure are rational and practical.



*Bottom row, left to right: classroom corridor with sun-screen formed by an open brick grill; looking southwest in garden patio; conference room staff and students in round-table discussion; stairs to library mezzanine; library (mezzanine contains student lounge and space for additional researchers' offices)*

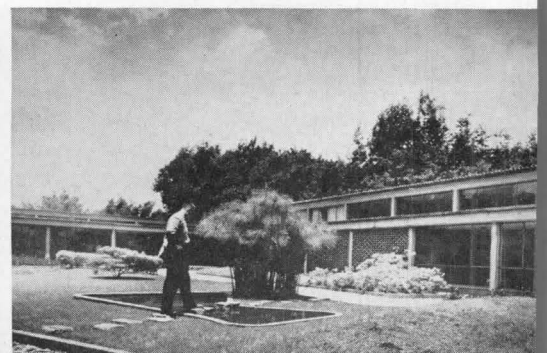



Garces—CINVA

*Left, garden patio, flags of nations comprising the Organization of American States; above, architects Mejia and Currie inspecting concrete placement on thin-shell roofs; below, simple concrete frame of the office wing*

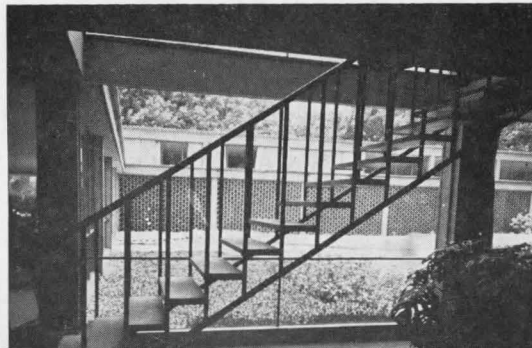
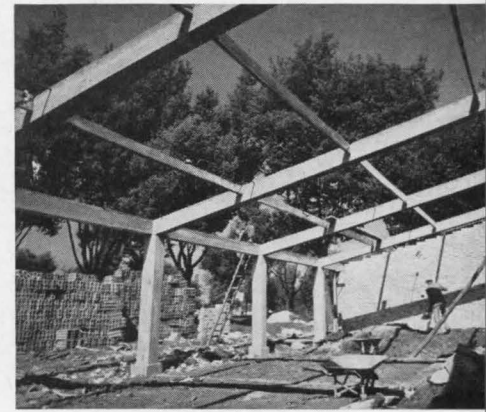

## INTER-AMERICAN HOUSING CENTER

Those who work or study or visit in the building, or in the building complex, become gradually aware of being part of a pleasant, non-assertive environment, a convenient environment that does not impinge itself upon the consciousness but rather provides a neutral background for the development of the individual and his personality. For those who insist upon architectural labels, the CINVA building might be called "old shoe" architecture; it fits its wearers with comfort and it is quite unconcerned with modishness.

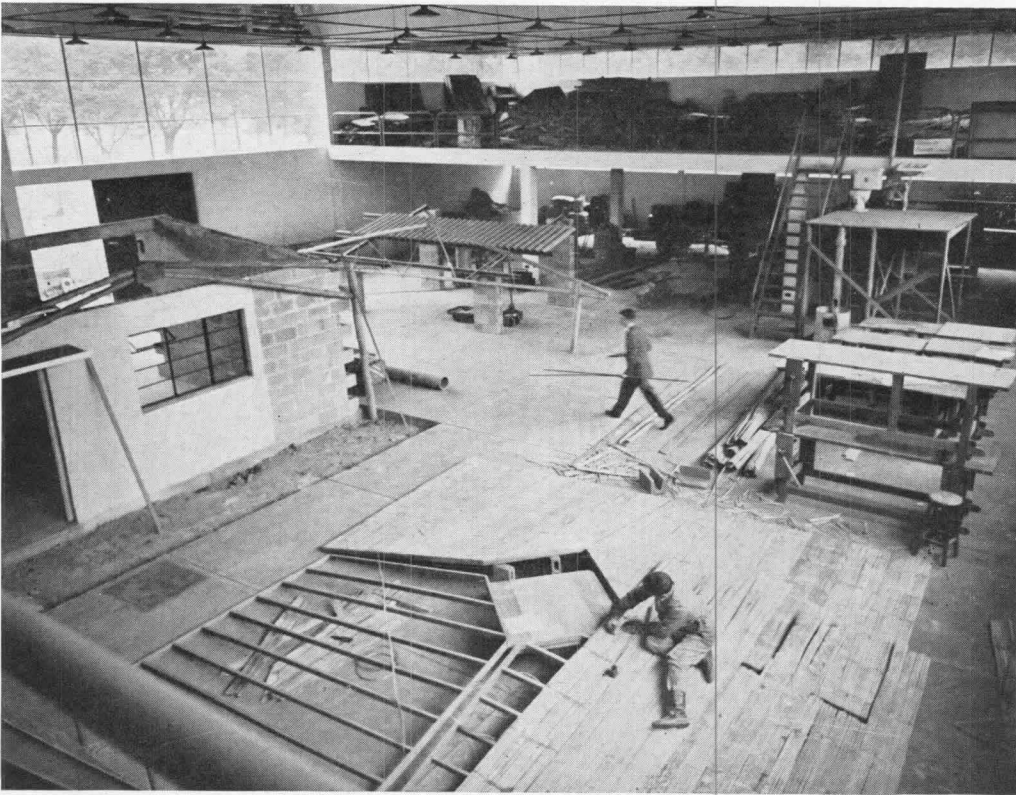

*Interior, experimental construction laboratory with, left, a mock-up of a developmental design; rear, plumbing demonstration; foreground, split bamboo form for an "umbrella" roof. Below, left to right, architects Mejia, Currie, de Roux, and builder Martin. A report on the Center's work appears in this issue's "The Record Reports"*

Forero—CINVA

Leo Matiz



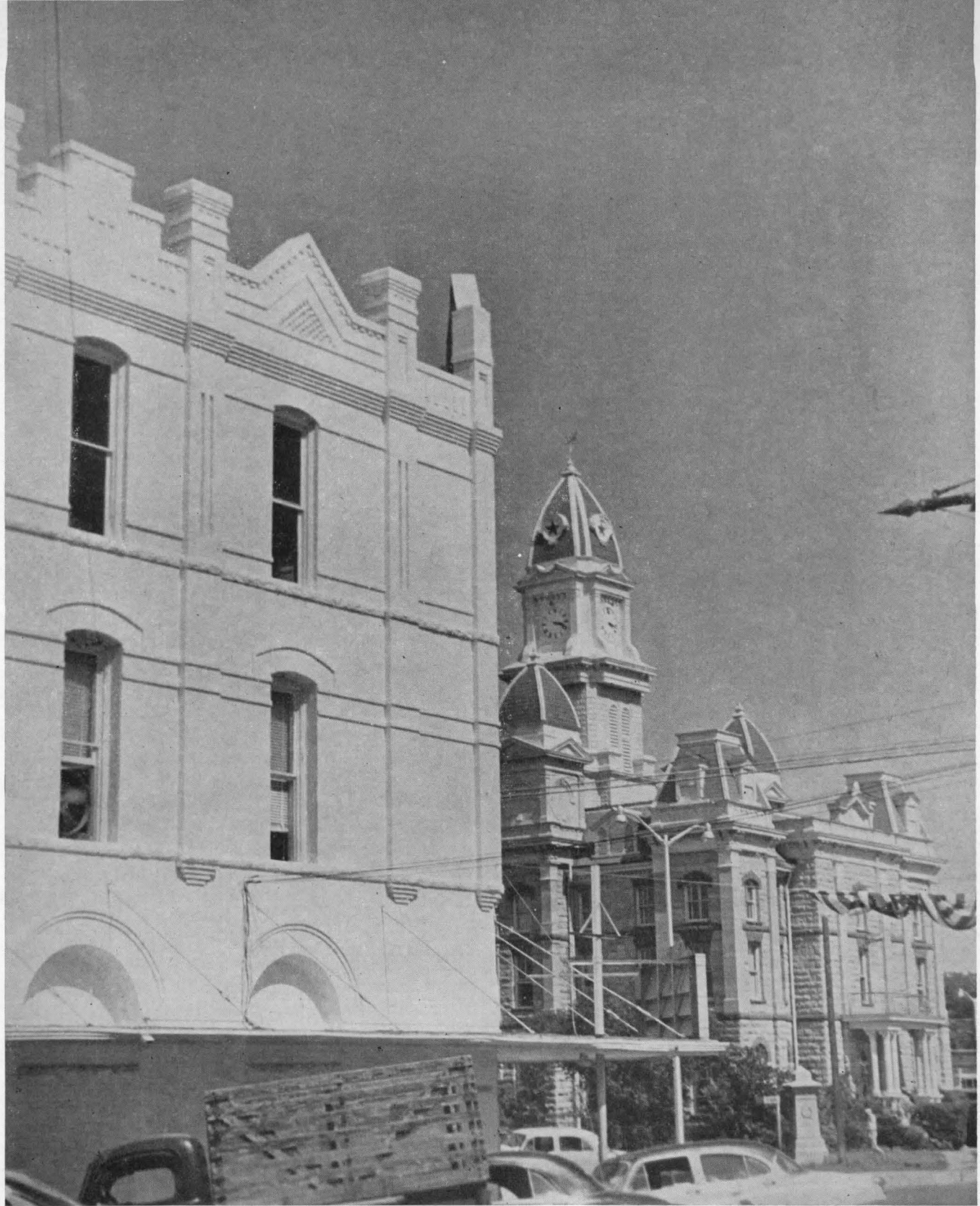

All photos by John Hejduk

## LOCKHART, TEXAS

By COLIN ROWE and JOHN HEJDUK

SOMEWHERE OR OTHER Gertrude Stein says that certainly America is the oldest country in the world, and if it may be supposed that she was simply straining a paradox, there is a perceptiveness in her remark which travelers in the United States sooner or later come to recognize, although the observation itself is perhaps one which could only have been made by an American expatriate returning to the American West. Certainly it is there, where the strata of historical activity are so few and where time has contrived to erode so little of the little past that exists, that there will sometimes be experienced a feeling of inextinguishable antiquity.



2 3

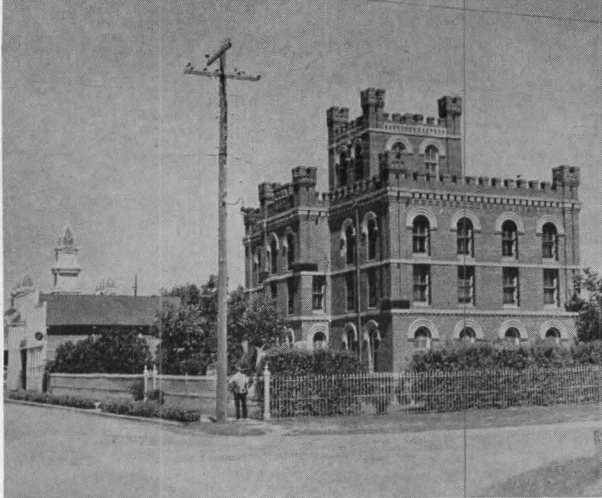

4

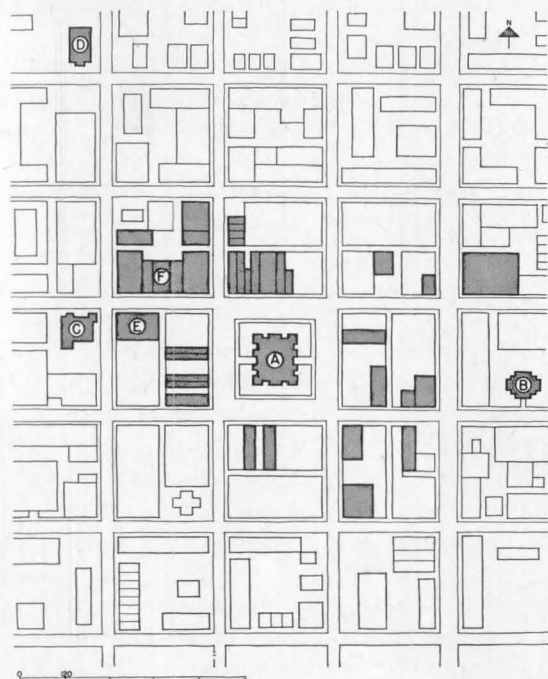

- A. Courthouse (Figures 1, 2)
- B. Jail (Figure 3)
- C. First Christian Church (Figure 7)
- D. St. Mary's Church (Figures 8-10)
- E. Vogel Block (Figures 11, 12)
- F. Masur Block (Figures 12-18)

This is a quality which evades any immediate definition; but often in the sharp light and the vacant landscape of the West architectural detail will seem to achieve an almost archaic clarity, so that the most tawdry saloon or incrustated false façade may acquire a portentous distinction, while whole towns founded no earlier than the 'sixties can exude an Italian evidence of age. For these reasons, for the sympathetic traveler Utah will evoke memories of Tuscany; Virginia City, Nevada, will appear a 19th-century Urbino; while such mining cities as Leadville, Colorado, Carson City, Nevada, or Globe, Arizona, will seem as unquestionably as Gubbio or Siena to have always occupied the land. Like the cities of Umbria they are potent symbols of urbanity; and like these they become more definite, more surprisingly crystalline to the mind, by reason of the emptiness through which they are approached.

How much of the present susceptibility to these towns is merely nostalgic, how much is pure hallucination, and how much corresponds to a reality, it is difficult to judge. Their buildings are scarcely inhibited by either taste or culture, were improvised apparently without thought, seem to be the embodiment of a popular architectural consciousness, and present themselves to the eyes of the present day as the final and the comprehensive monuments of an heroic age. But although it is by qualities such as these that Miss Stein's proposition is given substance, one hesitates to exemplify it by them alone. These western mining settlements are after all too bizarre to prove a point. One recognizes in their buildings a peculiar combination of good sense and outrage, of force and naïveté; but one really demands that these characteristics be embodied in a more completely typical situation.

It is here that, as a quite stereotyped urban pattern, the American courthouse town might be introduced as a more representative illustration. A completely normal and widely distributed type, scattered throughout the northern states, consistently recurring throughout the South, it is scarcely the product of any deliberately expressed taste — and yet one assumes its repetition was inspired by more than mere habit. For patently this is a town dedicated to an idea, and its scheme is neither fortuitous nor whimsical. The theme of centralized courthouse in central square is — or should be — a banal one. And it is in fact one of great



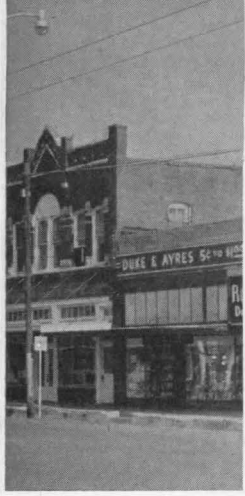

5



6

power. For these courthouse squares are not the residential enclosures of England, nor like the piazzas of Italy do they admit the church in a presiding role. Here it is the law which assumes a public significance; and it is around the secular image of the law, like architectural illustrations of a political principle, that these towns revolve. In each case the courthouse is both visual focus and social guarantee; and in each square the reality of government made formally explicit provides the continuing assurance of order. There is hence a curious decorum about these towns which, however run down they might often be, are apt to display an air of generality. Urbanistic phenomena they palpably are, but they are also the emblems of a political theory. A purely architectural experience of their squares is therefore never possible. Within these enclosures the observer can never disentangle his aesthetic response from his reaction as a social animal. They are the foyers of a republican ceremonial, and their uncompromised form neatly condenses all the imponderables of republican principles. It is the almost classical typicality, the emblematic significance, and the completely adequate symbolism of these towns that is responsible for their seeming antiquity.

The place of origin of the type is presumably a matter of academic interest, but it is just possible that its place of culmination is in central Texas. There at least, since the comparative absence of trees disencumbers the scheme from camouflage, one can never be unaware of it. Further west the central courthouse seems scarcely to have been a viable motif; but in Texas, where the brilliance of the atmosphere lifts the most modest architectural statement to a new potential, the *idea* becomes completely clarified; and for the unprejudiced eye, the eye which is willing to see, a number of small towns do present themselves as very minor triumphs of urbanity.

Llano, Lampasas, Gainesville, Belton, Georgetown, Lockhart, and others are all as much the same as so many French medieval *bastides*. If it is not the sight of a water tower, the first indication of arrival at one of them is apt to be the courthouse which appears, from a distance of several miles, as the slightest eruption upon the horizon. Without major incident the landscape has unrolled itself for mile after mile with an almost complete negation of picturesque effect. Ad-

mirable, uncompromising, repetitive, restrained, monotonous, subtle, and unvaried, it is a scenically underfurnished and magnificently exhausting display which makes the minimum of overtures to the spectator. Without natural punctuation and without natural relief, it debilitates the eye; so that as an artificial caesura in an endlessly continued scheme the distant view of the courthouse acquires a peculiar significance. It is like a ship seen in mid-ocean — an evidence of amenity, and a kind of monumental magnet which seems to impose progressive intricacy as the town is approached.

As a form of emotional complement to the interminable terrain, the impact of these four-square, geometrical, concentric little towns is discovered to be one of remarkable intensity. They have, all of them, something of the unqualified decisiveness, the diagrammatic coherence of architectural models; and scrupulously regular, they appear, almost more than real towns, to be small cities in primitive paintings. Something of their interest derives from their conformity, but within the accepted pattern innumerable variations are to be found. In one town brick will predominate, in another stone or stucco; in one place taste will be meager, in another elaborate; but in all of these places, as a common denominator of experience, there will be felt a dislocation of the sense of time. The buildings by which one is surrounded will appear to be ageless; while the insistently repeated courthouse and square will unavoidably suggest some Renaissance exercise to demonstrate the ideal significance of perspective.

As a representative of these towns at their best one might select Lockhart, whose exuberant, more than usually brilliant courthouse is apt to suggest that some provincial disciple of Richard Morris Hunt's had discovered the irresistible fascination of Leonardo's studies for domical buildings (*Figures 1, 2*). The first view of the town affords the characteristic visual competition. In approaching from the south the dominant intricacies of courthouse silhouette struggle for attention with the aluminum painted spheroid of the water tower; and a concentration of interest upon either is further disturbed by the appearance to the right of a small castellated building of curiously Vanbrughian profile. A toy fort, brick and machicolated, partly Romanesque and partly Italianate, evidently

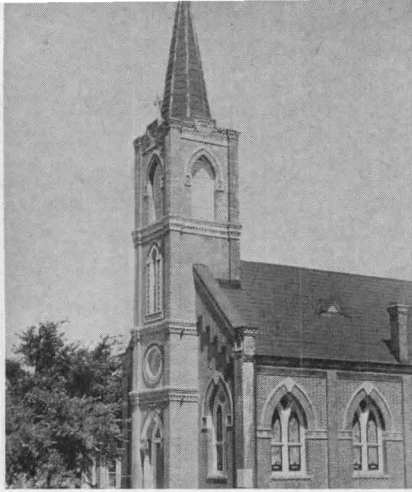

7 8



11

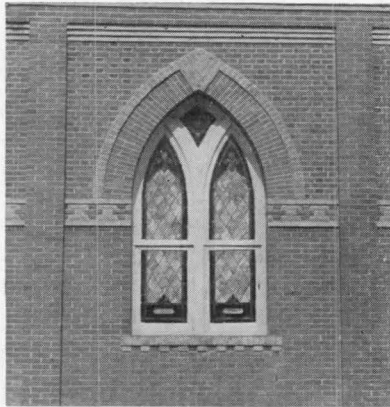

9, 10

the jail, its disarming self-assurance sets the mood for the entire town (*Figure 3*).

As a preface to the architectural promenade of Lockhart this little jail house could not be more appropriate, and as one is led imperatively from it towards the square it becomes apparent that expectations have not been raised too high. The courthouse is aggressive, bluff, and reasonably florid; the square itself is a more discreet combination of stucco, white paint, and Indian red brick, with here and there an intruding cast-iron column supplying a certain imported and Corinthian elegance. However, as one recovers from the shock of the square's central ornament, it becomes apparent that some of these minor buildings are not in themselves undemonstrative, and the presence of an interrupted staccato of distinctly assertive structures imposed upon the generally recessive background gradually becomes evident. It is particularly along the north and west sides of the square that these more individualistic buildings are concentrated (*Figures 4, 6*), and especially at the junction of these two sides that the presence of three white-painted gables of unequal height and width soon demands attention (*Figure 5*).

From this northwest angle of the square another phase of Lockhart's architectural evolution is revealed. A short block lined by small commercial buildings leads to a church tower some 300 feet away. The First Christian Church to which it belongs is as miniscule as the jail (*Figure 7*). An ecclesiastical representative of the Richardsonian suburban world of the 'eighties, dating from 1898, like the buildings in the square, it seems to have been put together from the standard elements provided by a box of bricks. But the First Christian Church is scarcely able to detain the observer, since three blocks down the street another disposition of church and spire presents itself.

This is St. Mary's, a product of Irish and German Catholicism, a building of orange brickwork relieved by brick of a yellow or deeper red and occasionally checkered, as for instance in the tower, with a pattern of greenish gray headers (*Figures 8, 9, 10*). St. Mary's is not so ambitious a building as the other; but its details are less ambiguous and more delicate, its modeling confident and distinguished, its Gothic both lyrical and strangely firm, with something of the economy of a child's drawing of a church. It is with shock that



12



13

one discovers St. Mary's to have been erected in 1918.

The common sense of metropolitan time is severely jolted by this improbable fact. That this diminutive monument of unassuming piety should be nine years younger than the Robie House, should post-date Gropius' Werkbund Building by four years, imposes a sober curiosity which leads one to examine with deference the buildings already passed by. These, the structures immediately preceding the First Christian Church, are the Vogel Block to the south of the street and the Masur Buildings to the north. The Vogel Block is the first to demand attention (*Figures 11, 12*). Dated 1908, invested by the heavy frieze-like elaboration of its roof trim with a majestic seriousness, almost a floating prism, it seems to stand in a transitional relationship between the buildings in the square and those across the street. An awareness of a single volume, a sense of the horizontal, and a feeling for the significance of the structural bay are all emergent in the Vogel Block. In the Masur Buildings they have come to control the entire design (*Figures 13 through 18*).

The Masur Buildings (extending also along the adjacent streets) (*Figure 13*) represent the ultimate achievement in the commercial architecture of Lockhart. Erected at a variety of dates down to 1918, except for the Jo Masur Building (*Figures 14, 15, 16*) they are more avowedly utilitarian than would earlier have been thought proper, and also more classical. In them the episodic detail which characterizes the square is no longer tolerated, the roof incident which still survives in the Vogel Block is suppressed, and the only interruption of their regular silhouettes is provided by the chunks of brickwork which form a capping to the thin pilaster strips of their façades. The three buildings across the street from the Vogel Block are large, simple, and distinct units (*Figures 14 through 18*). Linked by one-story elements, they read as a scheme of independent and varied pavilions, all manifesting the new ideal of congruity, which is now seen to acquire a decisive expression in the last of the series, the Jo Masur Building. There, subordinated to a controlling grid of string courses and pilasters, in simplified, almost abstracted, form, arches and all the acceptable components of a classical design are fused into a single statement of surprising intensity.

This three-floor hardware store, with all the con-

sequence of a small-town Italian palace, and the more fantastic Vogel Block confront each other across the street with a certain defiant individuality. The First Christian Church occupies another corner. The Catholic church is still in sight. And turning around, the perspective of the earlier buildings and of the north side of the square almost completes a survey of a series of apparently related structures. It is not necessary to itemize their resemblances. They are in themselves a convincing argument of their relationship; and standing between them, their intrinsic reasonableness, their authenticity, their unsophisticated strength, even their obvious weakness cause one automatically to presume the existence of some pronounced artistic personality, some architect, or more probably, since this is not architects' architecture, some builder. This personality rapidly takes shape, an unknown but not an indefinite figure, a master builder, a Master of Lockhart, whom one equips with the attributes one feels he should possess — an unsubverted integrity, an innate capacity, tastes which are uncomplicated and definite, an understanding of necessity. And for some moments — so strong is the light and so extreme the heat — the Master of Lockhart remains completely plausible.

But stubbornly, this ideally anonymous, quasi-medieval character whom one has educated refuses to take shape. The Master of Lockhart resists formulation as a myth. Indeed, was there one or were there several Masters? Was the architect of the Catholic church also the architect of the Jo Masur Building? Was the same man responsible for the Vogel Block and the jail? Apparently such questions are surprisingly difficult to satisfy and perhaps also they are irrelevant, because presumably it is the eternal problem of primitive art rather than the eternal problem of personality which is raised by these very recent buildings. They are structures which personally one finds deeply satisfactory; and yet, with any conviction, one cannot attribute to their designer a developed or a conscious aesthetic intention, and certainly not the intention to produce the results of which one is most deeply appreciative. Seen dispassionately, these buildings are utilitarian structures casually enlivened by an elementary eclectic symbolism, deriving something of their effect from concentration and material uniformity. But it is now impossible and meaningless to dismiss them as this



14 15

alone: in terms of a not unduly sentimental taste they have intrinsic virtues of a high order, while only too obviously their extrinsic attributes are even more telling.

Forty years ago, when the majority of them were new and some were still unbuilt, it was such a town as Lockhart that reduced the heroine of *Main Street* to an intolerable distress. "It was not only the unsparring, unapologetic ugliness and rigid straightness" which overwhelmed her, nor the fact that "in all the town not one building save the Ionic bank" gave pleasure to her eyes; but it was buildings "crowned with battlements and pyramids of brick capped with red sandstone" which really promoted her dismay, and it was in place of these that "she saw a new Georgian town as graceful and beloved as Annapolis . . . or Alexandria." "She saw in Gopher Prairie," Lewis tells us, "a Georgian city hall, warm brick walls with white shutters, a fanlight, a wide hall and curving stair. She saw it as the common home and inspiration not only of the town but of the county about"; and it was by fantasies such as these that she softened for herself the too harsh reality of a country which aspired "to succeed to Victorian England as the chief mediocrity of the world."

In the years that have intervened the neo-Georgian dream has receded, and as Victorian England has become less mediocre, so 19th-century America has become less abrasive. For many observers its towns have not yet become "as graceful and beloved as Annapolis," but their "rigid straightness" at least has become a positive value; while "their battlements and pyramids of brick" have become even more evocative than their English equivalents. They are now the indications of a self-consciousness as yet unimpaired by sophisticated inferiority or doubt, the distinguishing marks of a form of post-frontier architecture. It is a guileless architecture which, because innocent, is often apparently venerable; and which, because one may believe it to be uncorrupted, is sometimes curiously eloquent. When, as at Lockhart, it is combined with a city plan as entirely legitimate as that of the courthouse town; when, as there, a spontaneous and comprehensible architecture flourishes in a complementary relationship with a principle of authority; then we are in the presence, not of an amusing specimen of Americana, but of an exemplary urbanistic success whose meaning has been for too long obscured.

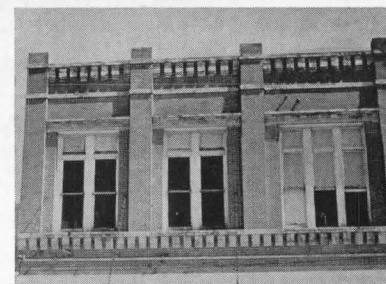

16, 17, 18

## 1. FOR A FAMILY OF TWO IN DANBURY

*Residence of Mr. and Mrs. Bernhard Stern*

*Herbert Beckhard, Architect*

*At first glance this house seems small and unassuming; a second look, however, reveals such fine exterior detailing that an interior of unusual interest is immediately suspected. And it exists, too, as the photos on the next two pages show. It exists in the selection of materials, the cabinet work, the lighting, and above all in the very workable plan for a family of only two.*

THE HOUSE was planned for a childless couple and a very occasional guest. Hence the one bedroom on the upper level and the guest room on the lower level where it can be closed off when not needed. The main view is to the north, and on that side the natural slope of the land was used to widen the upper level view and to bring the guest room above grade facing the view. The site is large enough to ensure privacy on all sides.

Despite its simplicity, the house is, as the architect points out, "rather luxurious, with two and a half baths (ceramic or mosaic tile walls), a separate dressing room for the master bedroom, a large living room, and good sized entry done in flagstones, double garage with electrically operated overhead door."

Ben Schnall



Ben Schnall

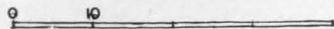
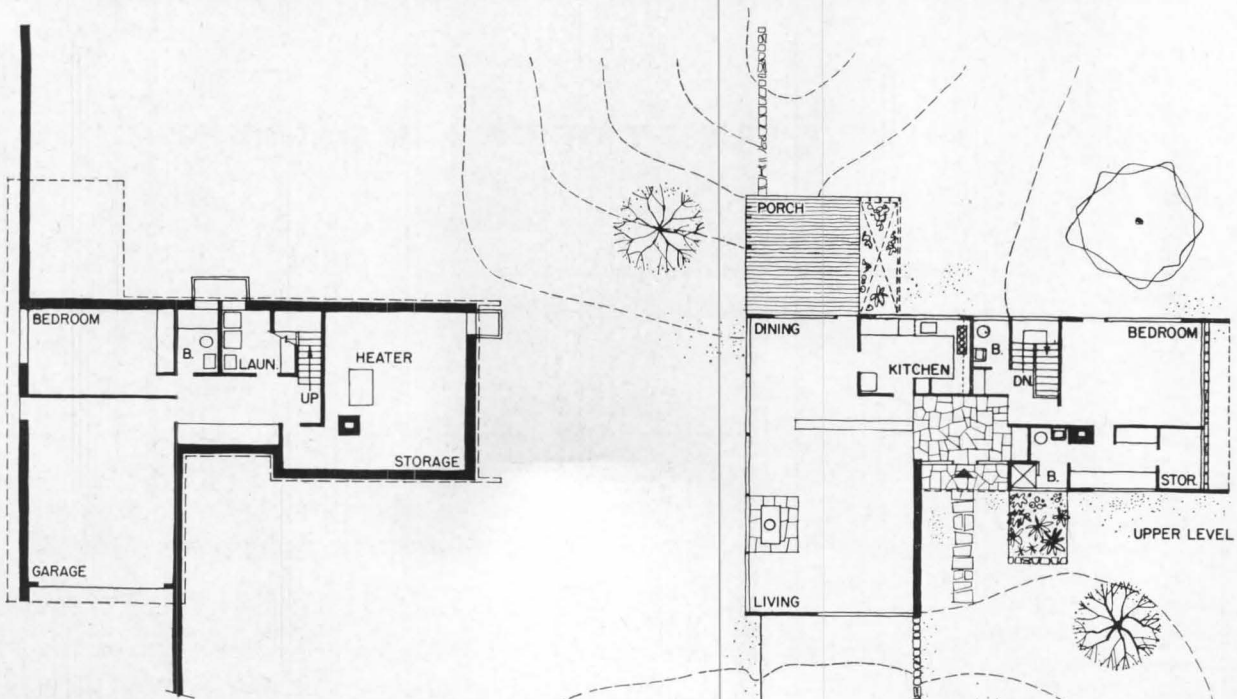

FOR A FAMILY OF TWO

*House is full of pleasant contrasts: the openness of living-dining area and the privacy of master bedroom, for example, or the bulkiness of living room fireplace and the all-glass wall behind it. Dining area is almost completely shut off from entry and living room by specially designed storage unit. Kitchen, small and compact at owners' request, serves easily to porch as well as dining and living rooms. Porch is open on three sides, "does fine job of capturing even the smallest air movement," the architect reports, "and is consequently a cool breezy spot even on the hottest of days." Exterior walls combine local fieldstone, cedar and plywood, with bright color accents of yellow and vermillion on the plywood panels under windows. Interior walls are painted gypsum board, floors are oak, slate or cork on upper level, asphalt tile on lower. Glass areas on north side are all double-pane*

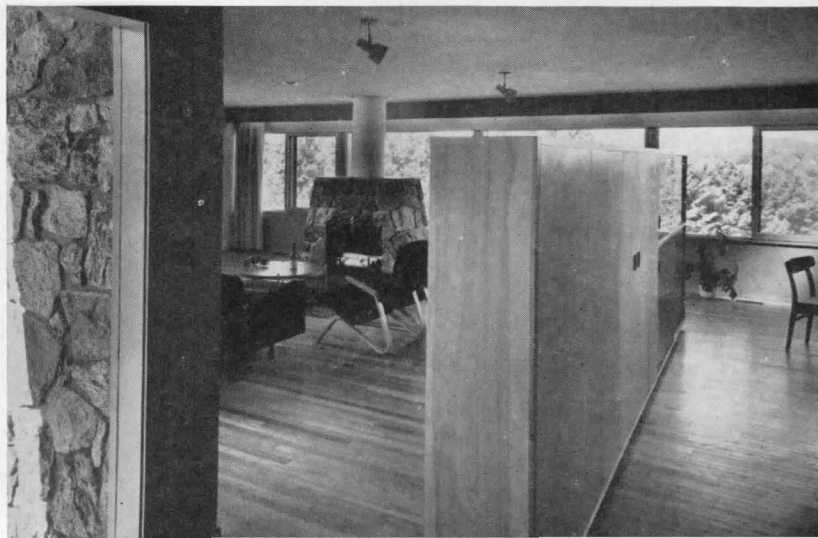
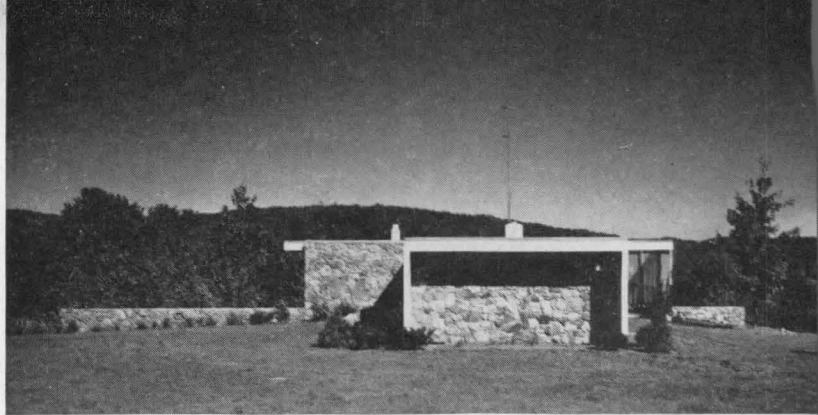

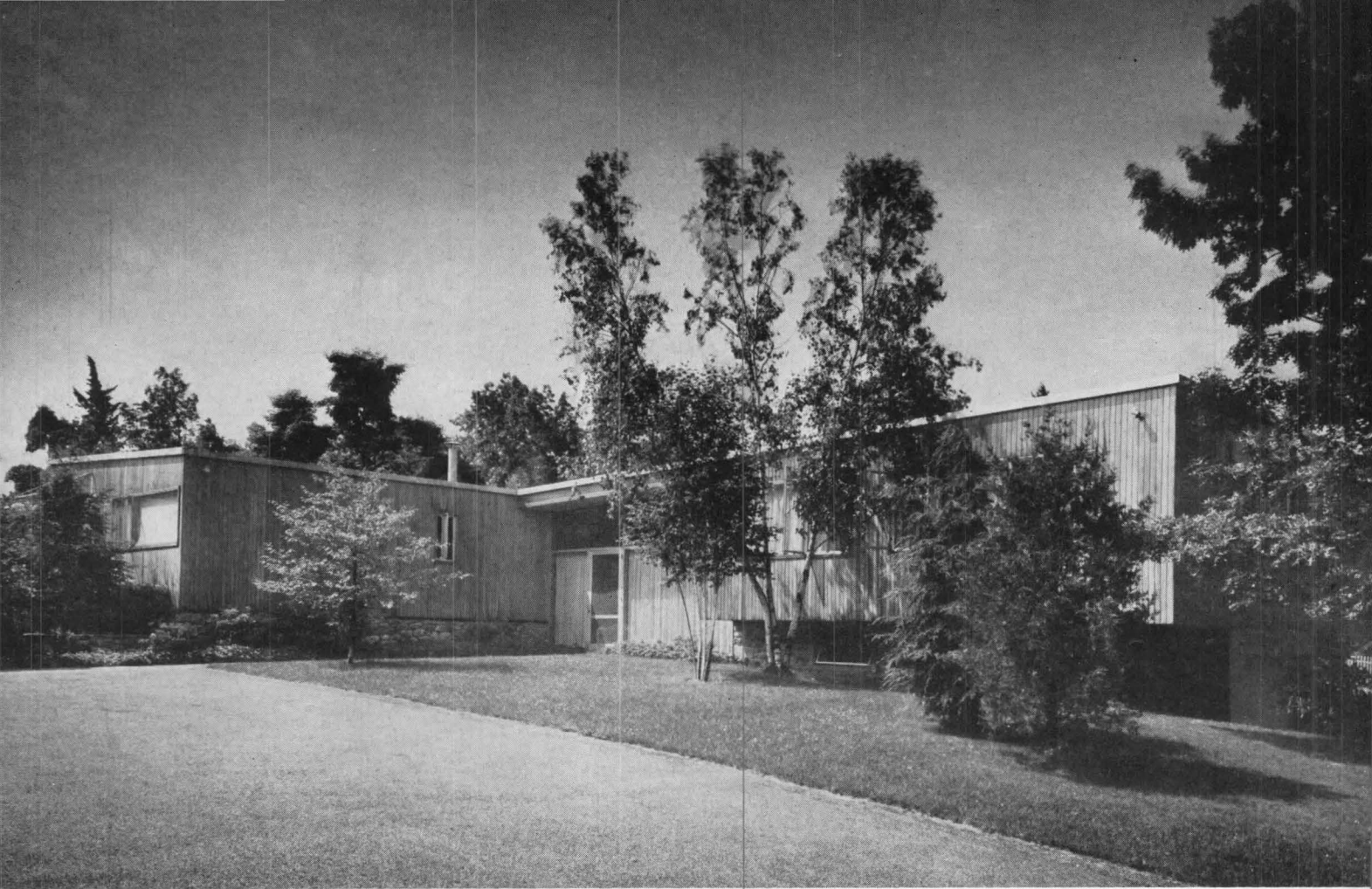

Louis Reens

## 2. FOR A FAMILY OF FIVE IN NORTH STAMFORD

*Residence of Mr. and Mrs. George Goldberg*

*Huson Jackson, Architect*

*H. Seymour Howard Jr. and Harold Edelman, Associates*

*Clean lines and the warmth of cypress siding give a quiet elegance to the exterior of this large house and pleasantly minimize its size. There is no hint from the broad motor court at the front of the depth of the building or of the lavish pool area to the rear. The site has been skillfully used by both architects and landscape architect to achieve a notable sense of serenity and privacy.*

UNLIKE THE HOUSE shown on the preceding three pages, this one was designed for a couple with three children and a maid. Here again, however, is the sloping site so typical of Connecticut — dropping off sharply to the north in this instance, and used to place the garage and utility room beneath a slightly raised bedroom wing. The living-dining-kitchen wing and the study are at the grade of the knoll south of the house and have adjacent outdoor terraces; the bedroom area is isolated from the living room by the entrance hall and study to permit the parents to entertain without disturbing the children. All main living areas are oriented and glazed to take advantage of solar heat in the winter and are protected from the summer sun by overhangs and outdoor shades.

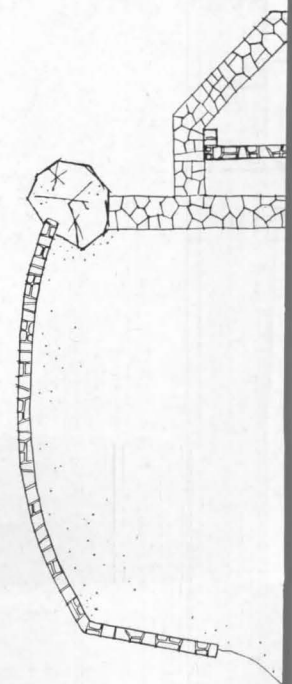





Living room (other photos on next page) is several steps up from entrance hall and separated from dining area by free-standing bookcase-storage unit; walls are walnut plywood, floors are terrazzo. Adjoining study serves as quiet recreational area, television or guest room. Cabinetwork and living room furniture by Devon Dennett and Harvey W. Blackman; landscaping by Robert MacKintosh

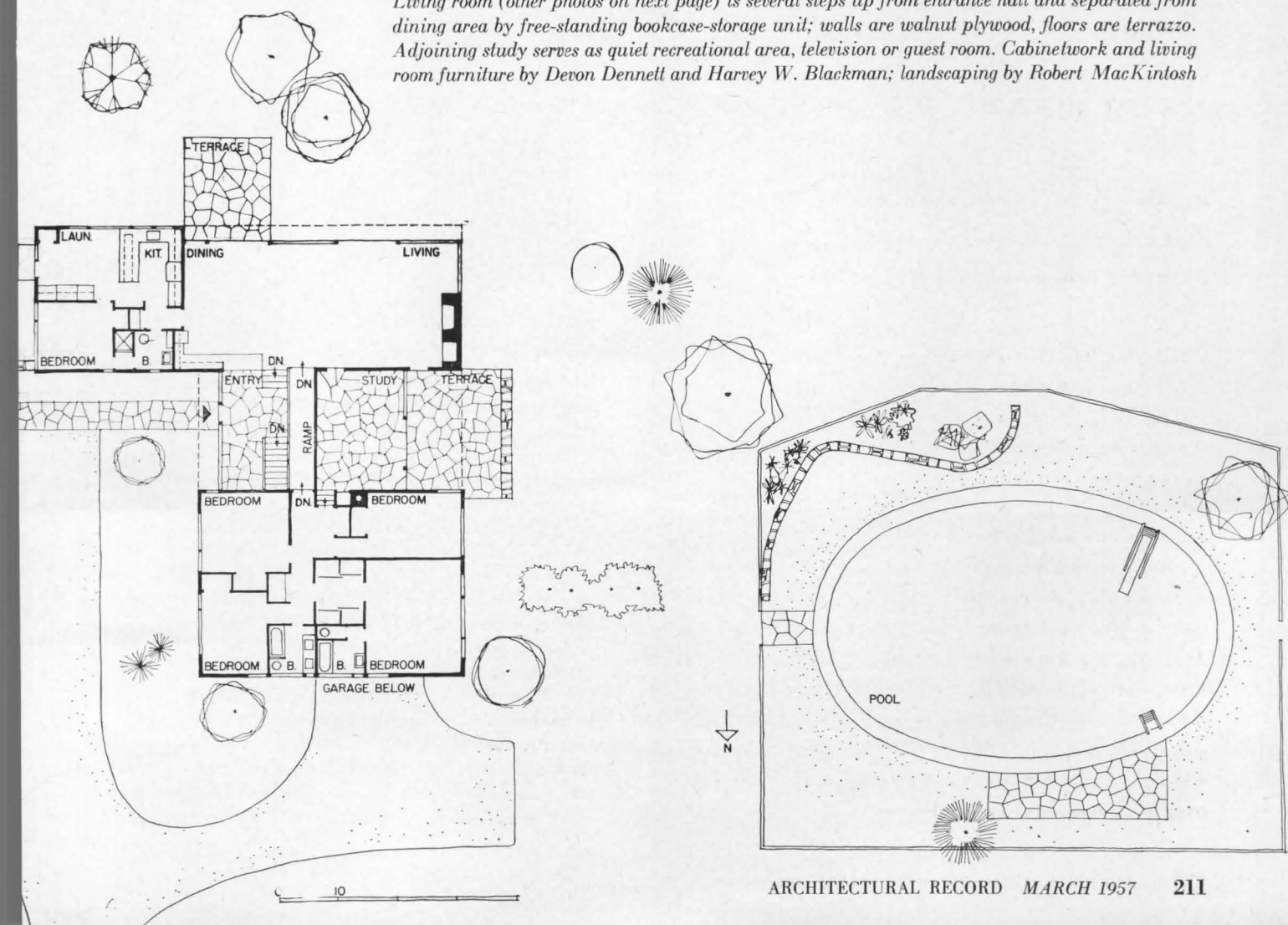

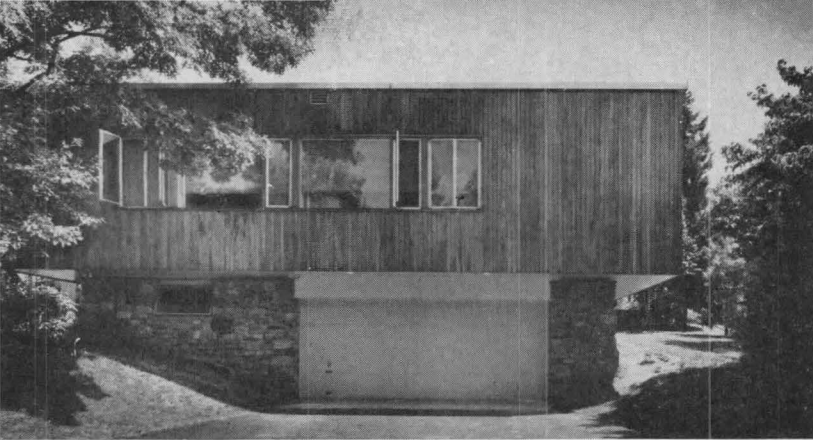

#### FOR A FAMILY OF FIVE

*Bedroom area over garage, living room wing and garage can all be reached directly from entrance hall from which steps lead up or down to the various levels; flooring here is fieldstone. Dining room overlooks entry, has built-in grill, generous counter and storage space. Interior wall surfaces are either walnut plywood or plaster, sand-finished and generally left unpainted; flooring except for entry and living-dining area is cork or linoleum, ceilings are sand-finished plaster, unpainted. All lights are on dimmers and all glass is double-pane. Foundation is rubble stone, framing is 2 by 4 studs. Sun control is provided by overhangs and exterior bamboo blinds, thermal insulation by glass wool bamboo blankets. Furnishings in living room, dining room and study and cabinets in children's bedrooms were selected or designed by the architects, who also planned swimming pool and its terraces*



**EAGLE ROCK CLUB HOUSE**

*Richard J. Neutra, Architect*

*Dion Neutra & John Blanton, Collaborators*

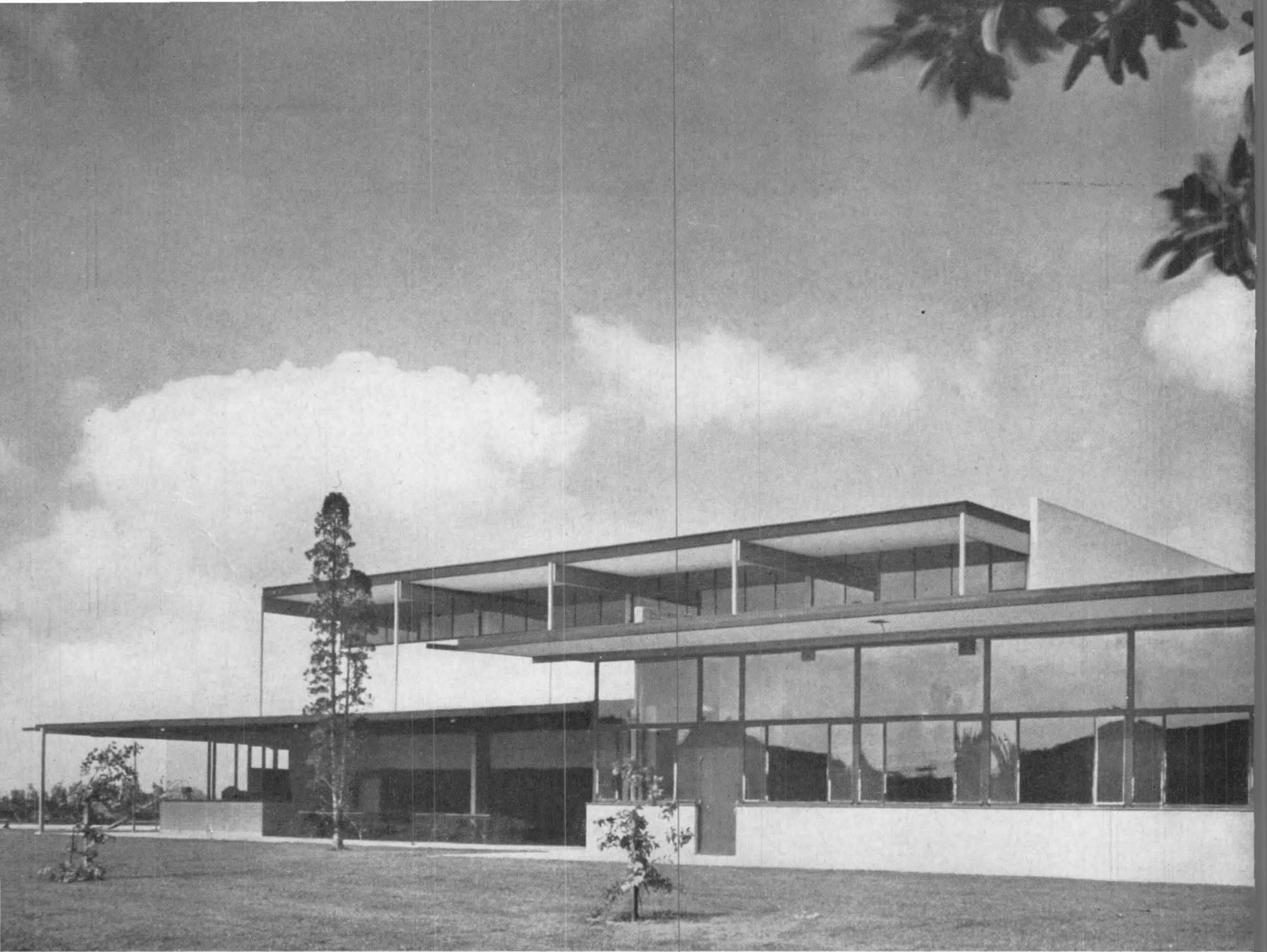

## THE EAGLE ROCK PLAYGROUND CLUB HOUSE

*This club-house building — winner of a national A.I.A. award — is readily adaptable to varied uses; a quality indeed basic to the very nature of its function. Its architecture holds considerable intellectual appeal; spatial and structural interest, fine proportion, carefully studied detail, a consistent and appropriate rhythm. Interpretatively, the architect apparently conceived the building as a neutral background for play, since the architecture itself conveys little sense of the light-heartedness of its purpose.*

\* \* \* \* \*

**T**HE SETTING strongly influenced the scheme, which is essentially a three-sided pavilion, openable at will. To

the north the hillside climbs slowly upward; to the south and east the ground falls off into ravines. Along its east and west sides the large central play hall was given vertical lift walls which, open, extend the volume out underneath and beyond the broad overhangs. On the east side (photo above) there is an outdoor play terrace which is unhampered by posts, since the roof here is hung from the cantilevered beam ends above.

At the north end of the building, the raised recital platform opens through over an outdoor reflecting pool to the hillside slope, thus creating an amphitheater or the alternate opportunity to utilize both indoor and outdoor seating for theater in the round.

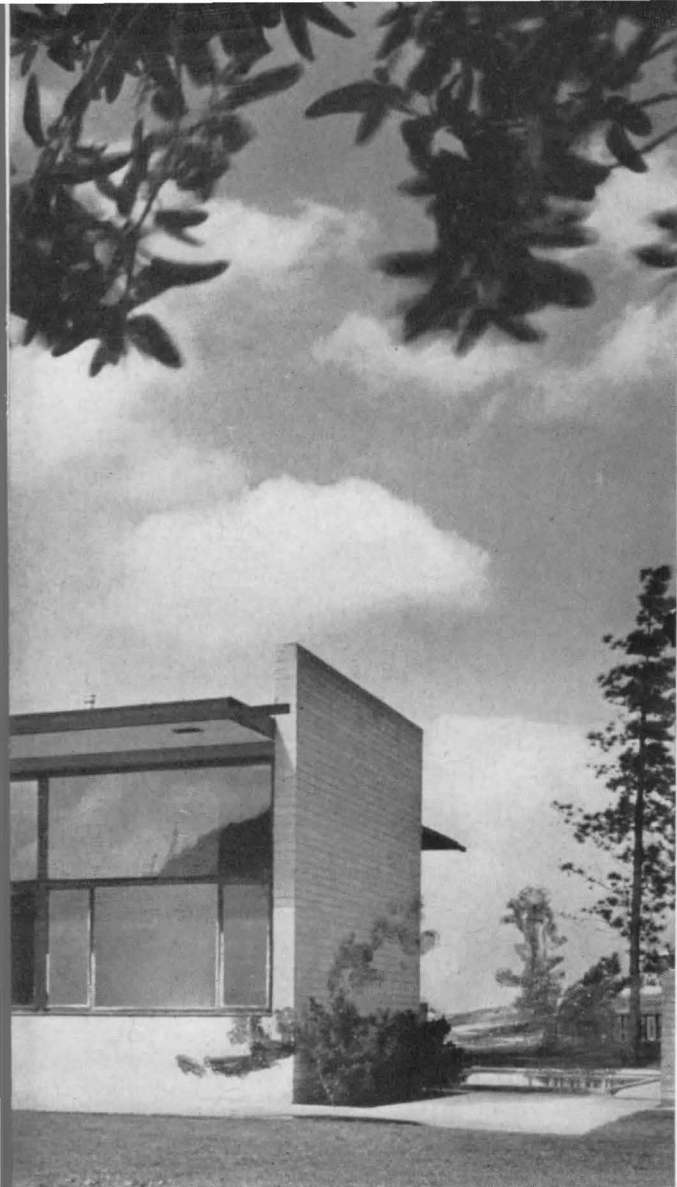

Julius Shulman (Also photo page 213)

Built for  
 The Department of Recreation and Parks  
 Los Angeles, California  
 George Hjelte, Manager

Richard J. Neutra, Architect  
 Dion Neutra and John Blanton, Collaborators

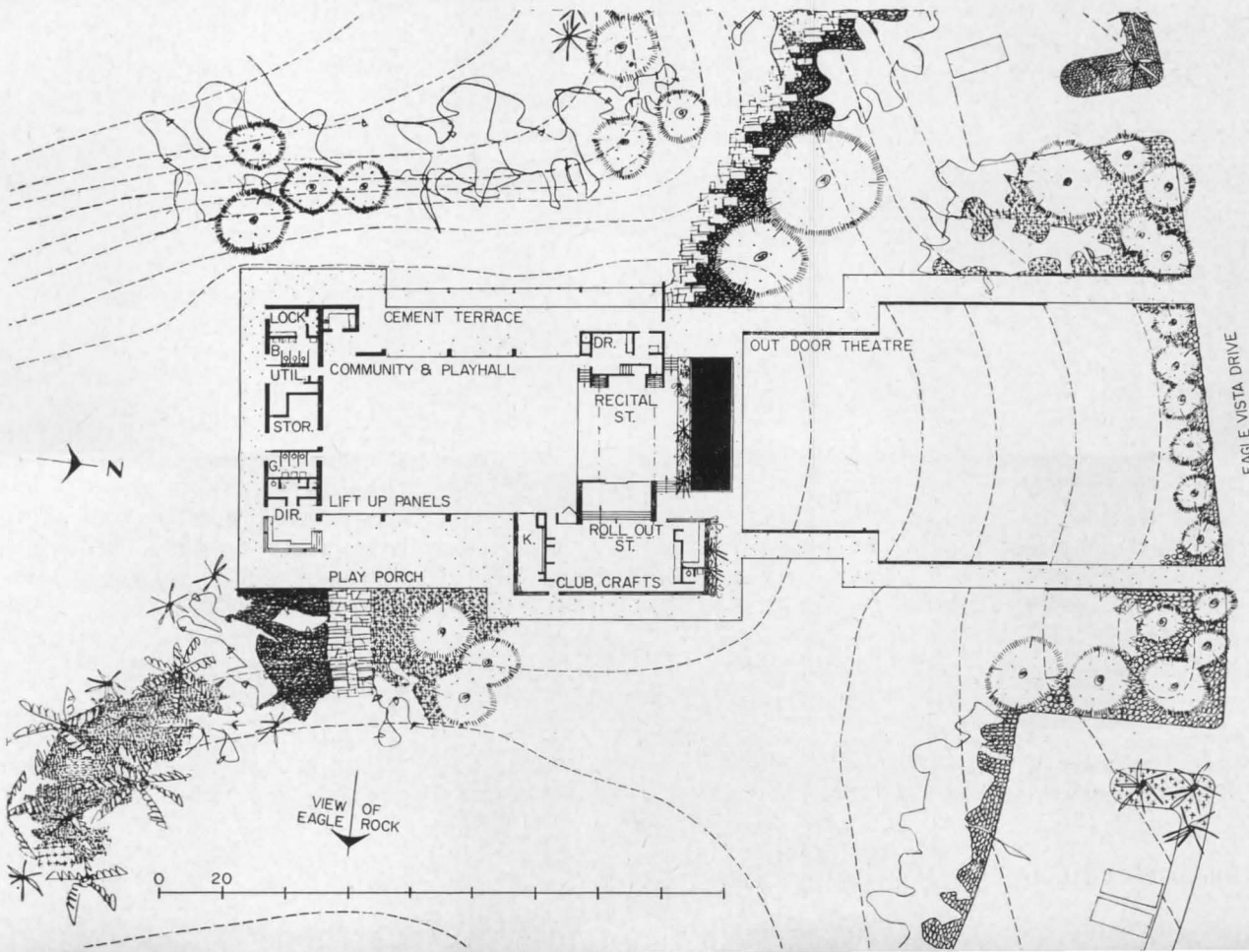

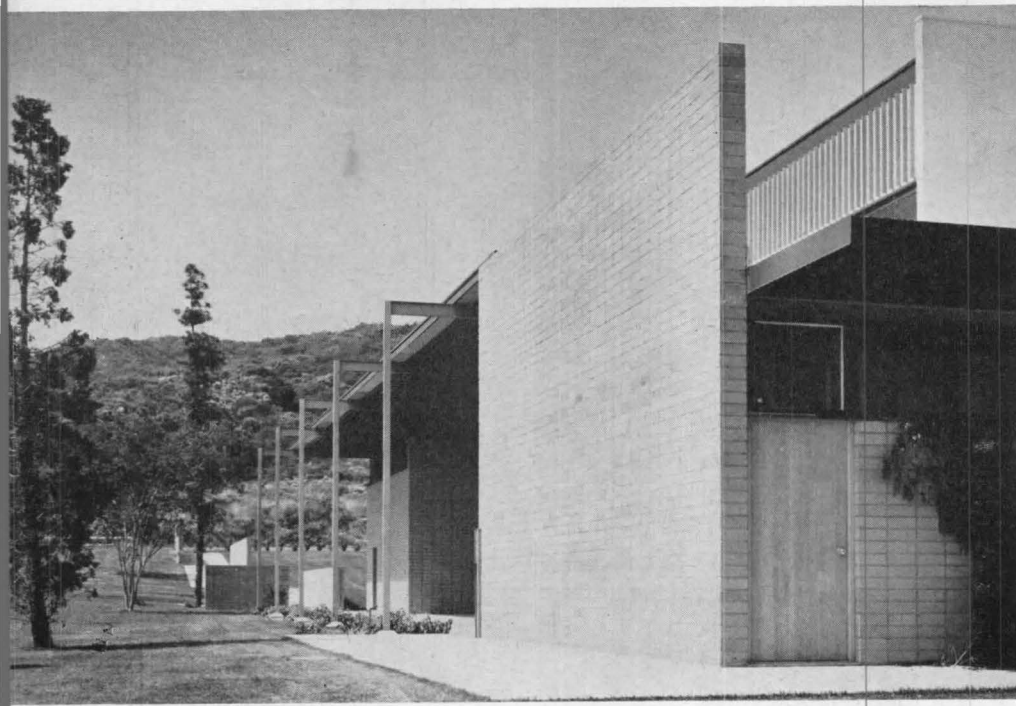

#### EAGLE ROCK CLUB HOUSE

*Exterior colors and materials act as an effective foil to the green of the surrounding park. The masonry is red brick; the exposed structural steel is painted aluminum, the steel deck soffits dark brown, the plaster white. Aluminum lowers serve both for sun control and decoration.*

*The sides of the main interior space — the community hall — consist of vertical lift doors faced with natural finish Douglas fir. The vertical tongue and groove boards tend to minimize the joints between fixed and movable portions of the wall. When the doors are lowered they form an attractive, continuous wainscot possessing considerable resistance to impact and scuffing. The ceiling panels are faced with acoustic tile; the upper wall and sash are painted dark brown; the playing floor is maple.*

*For the interior, the colors are predominantly rust, gray, yellow, brown and green. Except for the large room, floors are of asphalt tile and walls of painted plaster*



## A MUCH DISCUSSED THEATER DESIGN



*New City Theater, Münster, Germany*

*Architect Team: Harald Deilmann  
M.-Cl. von Hausen  
Ortwin Rave  
Werner Ruhnau*

*Consultants: Stage technique,  
Adolf Zotzmann  
Structure, E. Knoche  
Acoustics, E. Meyer  
Heating and  
Air Conditioning,  
A. Popp  
Electrical, H. Hancke*



## CITY THEATER, MUNSTER

THIS NEW CITY theater, talked about over Europe as a pace setter, departs from the traditional in concept as well as styling. The first new theater in many a day in Germany, it is widely observed as the significant statement of architectural thought, building technology, city planning trends, and theater theories of presentation.

Taking the last first, it is an approach to the theater-in-the-round but not a commitment to a single type of production. Thus it permits widely different stagings, but contributes to all an increased

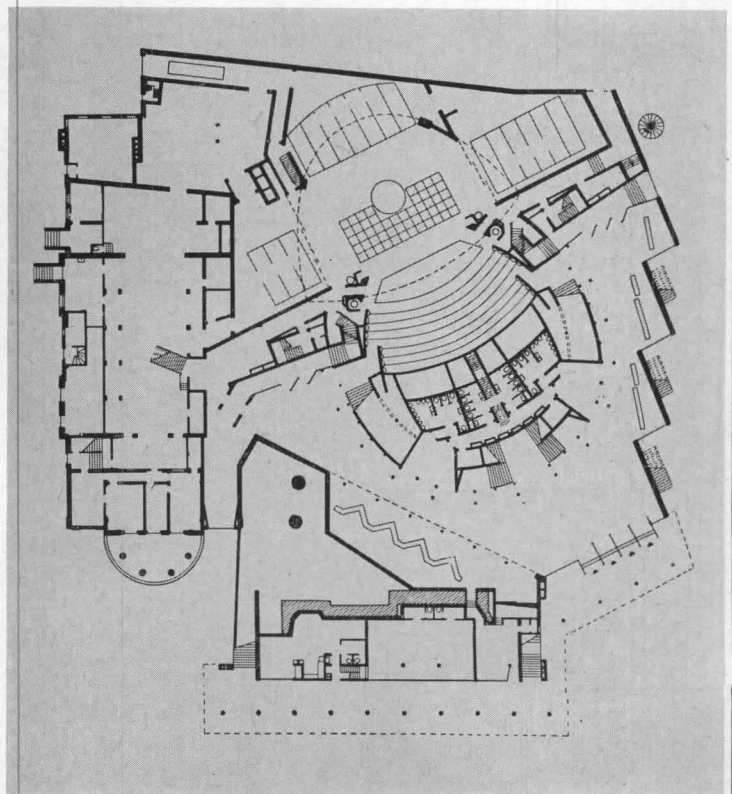



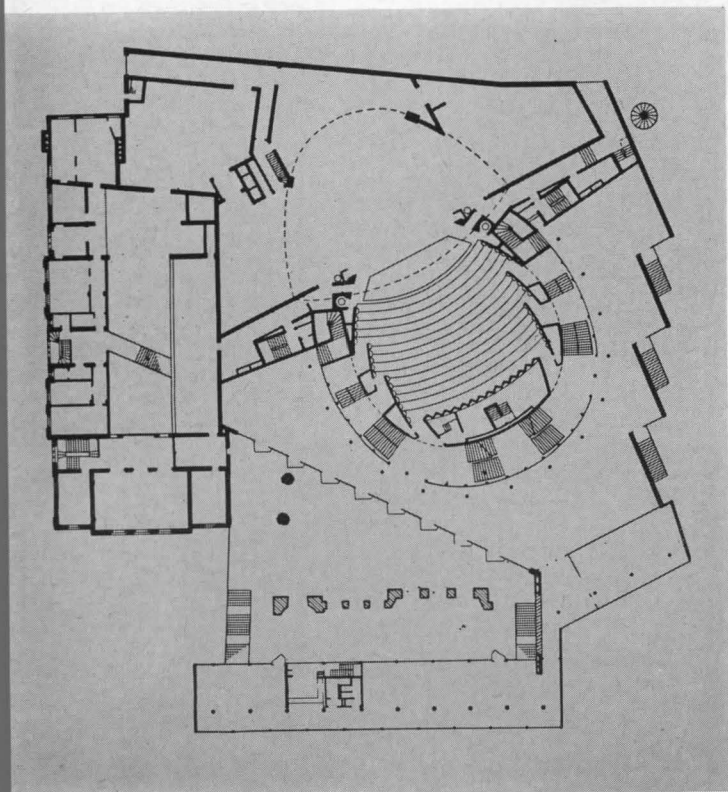

*Site at the corner of two heavy-traffic streets was freely but intensively developed to provide many spaces for social activities in connection with theater-going — restaurant, patio, large foyers and smoking rooms — also to create a theater which contributes in many ways to the life of the city*

sense of contact between stage and audience, a heightened feeling of participation, a “democratic theater community.” It is larger than the typical dramatic theater, smaller than an opera house.

Plan-wise, this concept finds expression in large foyer areas both indoors and out, smoking rooms, restaurant and a generally outward look, all calculated to encourage a conversational, social attitude about theater-going. An ancient ruin, a section of wall from a famous castle, was placed in the enclosed patio, no doubt as a conversation piece.



## CITY THEATER MUNSTER

*The fun-with-lamps idea extends to the restaurant as well as the theater auditorium. And, as shown by the photograph above, the basket weave motif progresses nicely to draperies and to wire chairs, or maybe it is vice versa. The restaurant as part of the theater is a very deliberate effort to give "the theater" an outward character, to heighten a feeling of social participation in connection with theater events*



WAINWRIGHT BUILDING, St. Louis  
Louis Sullivan

CARSON PIRIE SCOTT STORE, Chicago  
Louis Sullivan

ROCKEFELLER CENTER BUILDINGS, New York  
Reinhard & Hofmeister; Corbett, Harrison  
& MacMurray; Hood & Fouilhoux

LEVER HOUSE, New York  
Skidmore, Owings & Merrill

TRINITY CHURCH, Boston  
H. H. Richardson

PHILADELPHIA SAVINGS FUND SOCIETY  
BUILDING, Philadelphia  
Howe & Lescaze

GENERAL MOTORS TECHNICAL CENTER, Detroit  
Saarinen & Saarinen

LAKE SHORE DRIVE APARTMENTS, Chicago  
Mies van der Rohe

S. C. JOHNSON & SON, INC., ADMIN. BLDG., Racine  
Frank Lloyd Wright

MONADNOCK BLOCK, Chicago  
Burnham & Root

DAILY NEWS BUILDING, New York  
Hood & Howells

TVA NORRIS DAM & POWER HOUSE, Tennessee  
Roland Wank, Architect-in-charge

BOSTON PUBLIC LIBRARY, Boston  
McKim, Mead & White

STOCK PAVILION, Raleigh  
Nowicki & Deitrick

CHRISTIAN SCIENCE CHURCH, Berkeley  
Bernard Maybeck

WOOLWORTH BUILDING, New York  
Cass Gilbert

CROW ISLAND SCHOOL, Illinois  
Saarinen & Saarinen,  
with Perkins, Wheeler & Will

MANUFACTURERS TRUST BUILDING, New York  
Skidmore, Owings & Merrill

UNITY CHURCH, Oak Park  
Frank Lloyd Wright

NEBRASKA STATE CAPITOL, Lincoln  
Bertram G. Goodhue

S. C. JOHNSON & SON, INC., LABORATORY, Racine  
Frank Lloyd Wright

UNITED NATIONS SECRETARIAT, New York  
Wallace K. Harrison & Consultants

LINCOLN MEMORIAL, Washington  
Henry Bacon

M.I.T. AUDITORIUM, Cambridge  
Eero Saarinen

EQUITABLE BUILDING, Portland  
Pietro Belluschi

ALLEGHENY COUNTY BUILDINGS, Pittsburgh  
H. H. Richardson

UNIVERSITY CLUB, New York  
McKim, Mead & White

CRANBROOK SCHOOLS, Michigan  
Eliel Saarinen

MINERALS & METALS RESEARCH BLDG., I.I.T., Chicago  
Mies van der Rohe

ALCOA BUILDING, Pittsburgh  
Harrison & Abramovitz

MUSEUM OF MODERN ART, New York  
Goodwin & Stone

PENNSYLVANIA STATION, New York  
McKim, Mead & White

EXPERIMENTAL SCHOOL, Los Angeles  
Richard Neutra

DODGE TRUCK PLANT, Detroit  
Albert Kahn

100 MEMORIAL DRIVE APARTMENTS, Cambridge  
Kennedy, Koch, DeMars, Rapson & Brown

CENTRAL LUTHERAN CHURCH, Portland  
Pietro Belluschi

#### HOUSES

F. C. ROBIE, Chicago  
Frank Lloyd Wright

E. J. KAUFMANN, Pennsylvania  
Frank Lloyd Wright

TALIESIN WEST, Arizona  
Frank Lloyd Wright

HENRY VILLARD, New York  
McKim, Mead & White

WATTS SHERMAN, Newport  
H. H. Richardson

AVERY CODNLEY, Illinois  
Frank Lloyd Wright

W. W. WILLITTS, Illinois  
Frank Lloyd Wright

D. R. GAMBLE, Pasadena  
Greene and Greene

PHILIP JOHNSON, New Canaan  
Philip Johnson

WALKER GUEST HOUSE, Florida  
Paul Rudolph

ELLEN SCRIPPS, La Jolla  
Irving Gill

WESTON HAVENS, Berkeley  
Harwell Hamilton Harris

LOVELL "HEALTH HOUSE", Los Angeles  
Richard Neutra

EDITH FARNSWORTH, Chicago  
Mies van der Rohe

## ONE HUNDRED YEARS OF SIGNIFICANT BUILDING

### 10: INSTITUTIONS

THE FIFTY BUILDINGS nominated by ARCHITECTURAL RECORD's panel as "most significant in the past one hundred years" have divided themselves, generally, into convenient installments according to building type. Although the museum, club, and library grouped here as "institutions" share few specific functions, there is even among these three buildings a considerable common denominator.

In their general form all are descendants — although at clearly different removes — of the renaissance palace. All conceal the number of their principal stories and depend heavily on that concealment to achieve the major ingredient of their common success: good scale.

The great office of McKim, Mead & White — represented with four buildings in this total series — was almost always able to resolve the differences between direct and conditioned responses to size in such a way as to avoid the grotesque and achieve the grand and the gracious.

A long generation later the Museum of Modern Art — in the skilled hands of Philip Goodwin and Edward Stone — responded no less sensitively and with necessarily more courage to an array of conditioning phenomena inevitably eroded and remolded. Even those who could not feel it at the time of its building must surely acknowledge this work both prophetic and expert.

It offered for many their first thorough experience of a thorough-going modern public building. For almost twenty years a trip to New York has included a visit to the museum, where the building itself was often its own best and most carefully studied exhibit.

Just so was its University Club neighbor admired and studied and, in its time, the library in Boston. All had — and have — many lessons to teach; none more significant than the importance of scale.

## ONE HUNDRED YEARS OF SIGNIFICANT BUILDING

### *Boston Public Library, 1888-95, McKim, Mead & White. (Tied for tenth)*

"The Boston Public Library has especial significance in the history of American architecture because it marks the dawning of a renaissance in taste, a taste which had the capacity to understand the past and use the language of the past with sincerity to give expression to the modern need for the beautiful. The Richardsonian arch had been abused by inept imitators. McKim made use of the arch that had been so well and so differently used by Richardson in Trinity Church across Copley Square. He followed the arrangement of the arch as it had been applied in the Library of Sainte-Genevieve in Paris, but he gave his composition for the library a greater freshness and a richness of detail and refinement that far outshone the prototype.

McKim refrained from using the then popular classic columns on the exterior, yet used them skillfully to give scale to the grand staircase which led up to the long reading room that ran across the front on the second floor. Both column and arch were used to give intimate and humane scale to the lovely interior court which was intended to be dominated by the

joyous abandon of 'MacMonnies' Bacchante,' but which the prudery of Boston of the early 20th century was not yet able to understand."

*Arthur C. Holden*

"The Sainte-Genevieve Library in Paris gave McKim, Mead & White motive for the Boston Public Library. McKim took the pattern and with his skill built its theme into a much greater building. He and his partners, realizing the importance in position and purpose of the library, unselfishly urged the creation of a building which would be outstanding not only because of its architecture but because of its combination with the work of foremost artists and sculptors.

The architects felt, as all fine architects strive to feel, that no sense of unaided personal achievement exceeds satisfaction in knowing that they have created an everlasting monument by collaboration with others, even though their own personal glory may be somewhat dimmed. It is the joy, not of acclaim, but of creation."

*Edwin Bateman Morris*

*Joseph W. Molitor*





Joseph W. Molitor

*University Club, New York, 1900, McKim, Mead & White. (Tied for seventeenth)*

"It has been said that the genius of McKim, Mead & White was only great enough to make reasonable facsimiles of other buildings. But their skill and good taste stepped up the charms of the originals, and made greater architecture.

The University Club stemmed from the strong simplicity of the Strozzi Palace. Its design adroitly adapts the great masonry expanse in the Strozzi from window heads of one story to sills of the story above, which expressed vault construction, into additional stories, beautifully worked into the facade.

Straightforwardness and well-placed ornament offer this building elegance combined with simplicity, which give it a claim as enduring architecture." *Edwin Bateman Morris*

"'An Italian palace on the outside, but better than any in Italy, with two atriums better than any in Pompeii, a library modeled on that of the Vatican, but better, and its dining room greater than any English great hall, it is undoubtedly the finest building in the world!' — the hyperbole of a French visitor quoted by Royal Cortissoz has considerable justification. The plans, elevations, and interiors are as fine in fact as on paper, and, like the Villard houses, the best artists and artisans were employed for their fulfillment. A period piece in the grand manner, it should be presented and admired forever."

*Edward Steese*

ONE HUNDRED YEARS OF SIGNIFICANT BUILDING

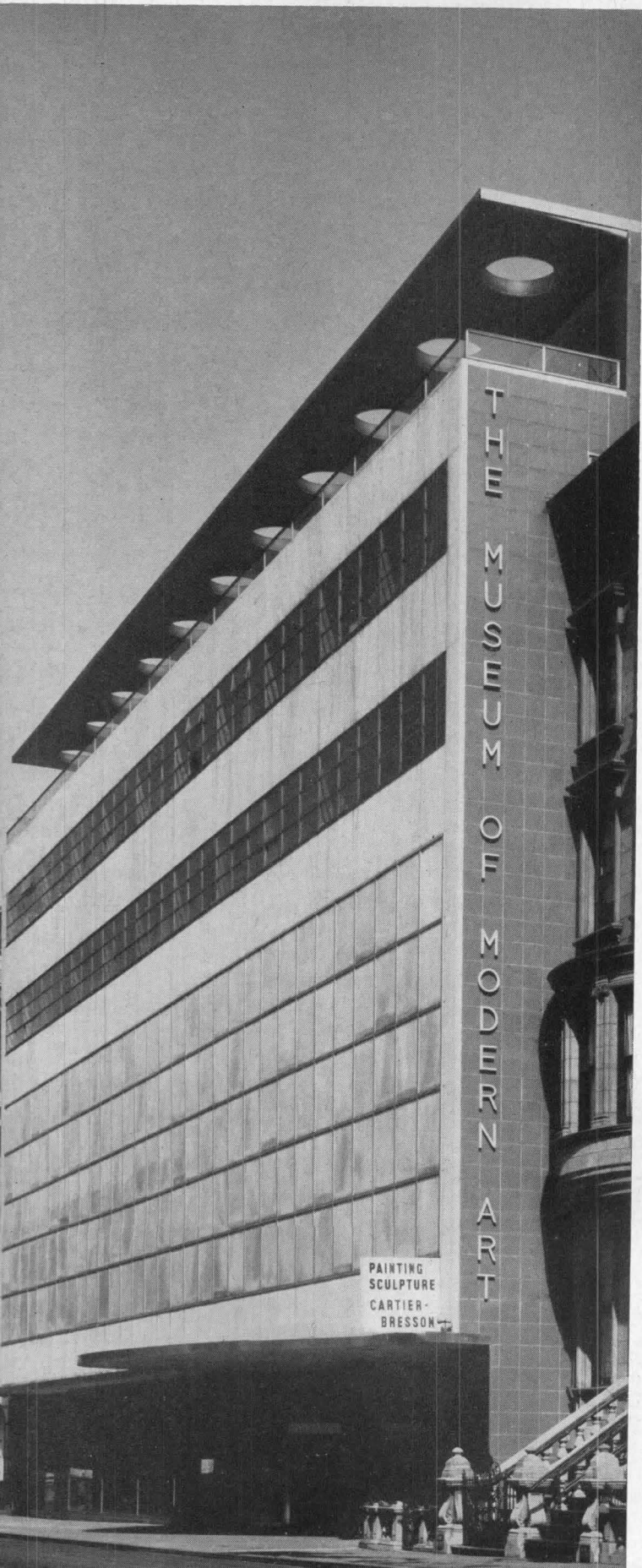

James Hornbeck

*Museum of Modern Art, New York, 1939, Philip L. Goodwin and Edward D. Stone. (Nineteenth)*

“The afflatus of the Museum of Modern Art lies, it seems to me, in the influence of its basic approach beyond even its handsome realization. For this building — designed almost twenty years ago — shattered the sacrosanct concept of the *valhöll* museum where one must be bulldozed into submission by the monument before reaching even the front door. Philip Goodwin and Edward Stone sought no monument here: the Museum of Modern Art was to assert art, not itself. Yet this it does with such an enticing graciousness that the architecture alone has played no small part in the growing art awareness of America today. For this was the first museum to make art both easy to attain and exciting to enjoy.”

*G. E. Kidder Smith*

# OFFICE BUILDINGS

Ewing Galloway

**BUILDING TYPES**

®

**STUDY 244**

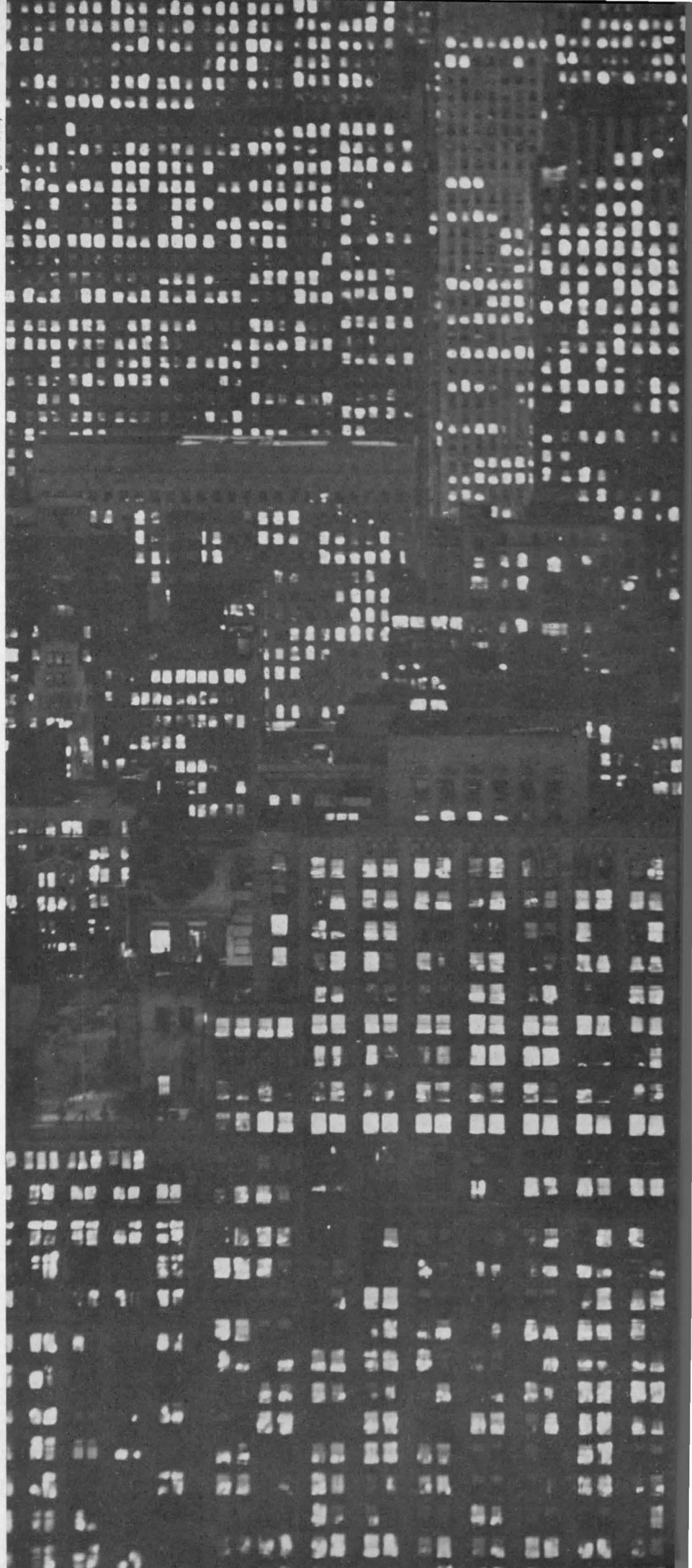

## A REVIEW OF THE NEW SKYSCRAPER

by James S. Hornbeck

*Pausing amidst today's feverish office building boom to consider the nature of the new towers that are climbing skywards in every city, one is inevitably struck by such questions as: has the skyscraper infant born in Chicago 70 years ago matured at last, or is it still in the growing up process? Is today's office building basically different from those 25 years ago, or is it the same thing in a shiny skin? What of these considerations: the shape of the building; the handling of the plot; the influence of mechanical systems and lighting; the use of color — and further problems? What are we to expect in the future?*

*All these matters — and others — were discussed with the architects responsible for most of these buildings, and those discussions constitute the major ingredient in this report.*

Despite the lessons of Louis Sullivan, skyscraper design stubbed its toe on traditionalism early in this century and has regained balance to step forward with assurance only in the past 25 years. Today, the tall office building — in its best manifestation — can take its place in architectural history as a new and valid expression; one that embodies a fundamental articulation of space, structure, material, and utilities in a manner true to contemporary industrialized technology. The curtain-wall plus skeleton cage can be added to the historical listing of construction methods, along with the post and lintel, arch, and vault. The office building has become a useful (and sometimes beautiful) tool for our kind of society. But it remains for man to relate it to the total community. To design both as one — that is the challenge for the future.

**Height, Shape, Economics** Since it is a commercial venture, an office building that fails as an investment would be better never built. Commercial considerations will inevitably dictate both its working size and rentable shape. These basics must of course be tempered by zoning requirements, common sense, and esthetics — but the end result must please the bankers.

It is well known that expensive property dictates a tall building for adequate rental return; a ten-story building at Park Avenue and 50th would be a disaster. The added cost of constructing a higher tower is offset by the premium rentals the upper floors bring — such space is quieter and cleaner; offers daylight, privacy, prestige, and a view. At any level, the area not more than 26 to 30 ft from daylight (inner plus outer office) pays larger rentals than dark space — hence the popular slab form. Constructing large-area floors with much inside space (i.e., the zoning ziggurat) is in most cases



penny-wise and pound-foolish, for such space brings a lower rental in good times and in hard times possibly none.

The picture today: a real estate boom plus unprecedented demand for space plus high building costs mean higher buildings, higher rentals. The trend to taller, leaner buildings is everywhere evident.

**The Plaza** The principal difficulty with today's sky-city is the ground-city below, where confusion, congestion, and esthetic chaos prevail. In the city, an open space with a touch of green is a blessing, as the architects (and owners) of Rockefeller Center demonstrated in the 30's. The lesson stood without emulation until the early 50's; but more recently the value of ground-space and planting has received wider recognition so that today, one can point to several further examples, and more are on the drafting boards.

At present, the plaza idea seems to be restricted to projects for corporate clients willing (and able) to make a conspicuous gesture for the sake of the prestige, amenity, and aura of success such a scheme lends their business headquarters. However, the hard fact remains that when a part of such space is leased, it yields top returns. Speculators please note!

The lower floors of office buildings (as well as their settings) are due for more intensive study; the day of the lobby-elevator-rental-area plan is shortening. Furthermore, traffic chaos and the development of suburban shopping have combined to place at least a question mark on the continuing value of ground floor shopping space.

If city usefulness and amenity are to be reborn, future planning must extend beyond a concern with the plaza or block and must encompass entire street patterns or indeed whole multi-block and neighborhood developments. Therein lies the future.

**Structure and Skin** Today, the steel cage — complete with cantilevers — is a highly developed commonplace. Welding will provide continuity and greater efficiency but will not alter its fundamental shape; the structural future would appear to lie in completely new concepts. Wright has advanced one\*; there will undoubtedly be others.

The lightweight curtain-wall has come of age in the form of a modular, industrialized unit. For its facing, a variety of materials have been used, tried, or dreamed of — with more to come: glass, plastics, thin stone, metals, ceramics, etc. There are exciting potentials here; but considerations of facings will scarcely alter

\*The deeply rooted central core that supports cantilevered floor slabs, made hollow for utilities.

the fundamental nature of this curtain-wall. Some maintain that its modularity gives scale and character to surfaces — others contend that its basic weakness lies in its monotony and jointing. These latter further predict that our ultimate construction will involve a building in which there is continuity of skin, continuity of structure, and continuity of skin and structure.

**Glass** We now see the glass wall, the modified glass wall, and the blind curtain-wall interrupted by vision panels. There is wide use of various kinds of colored glass, ostensibly to reduce sky-glare and cooling load. Out of all these variants no clear trend or uniformity appears, which is probably all to the good.

There does seem to exist, among clients, a continuing demand for large glass areas, despite the fact that many occupants then proceed to cover considerable portions of this glass with venetian blinds, hangings, etc. One owner says, "it is well to have it there so the tenant can use it as he wishes."

The problem of interrupting sunlight before it reaches the skin of the building promises to create a whole new series of patterns, textures, and even profiles for our tall and likewise for our lower buildings.

**Color** Traditional architectural conservatism with color appears to be undergoing a change, for increasing numbers of office buildings use color — muted or vivid. This development, tastefully handled, can lead to the kaleidoscopic city — not an unpleasant prospect, provided clean air makes it possible for one to view it and maintain it in all its radiance.

**Air, Light, and Sound Control** These are not last in importance, for air conditioning, sound control, and good lighting are office building musts today. High-velocity, small-duct systems for air distribution are now a well developed reality widely used, often in a peripheral belt supplemented by the central core system. For illumination, the demand runs to ever higher total intensities from large, low-brightness sources. Modular ceilings incorporating lighting, sound control, sprinkler heads, and air diffusers are now stock items — evidence that such utilities are increasingly thought of as part of the building and not as added fixtures in bits and pieces. The future will see the integration of all utilities into the very fabric of the building itself.

*No one of the buildings that follow demonstrates all of the foregoing principles and ideas. All of them demonstrate most of the elements that characterize the new office building.*

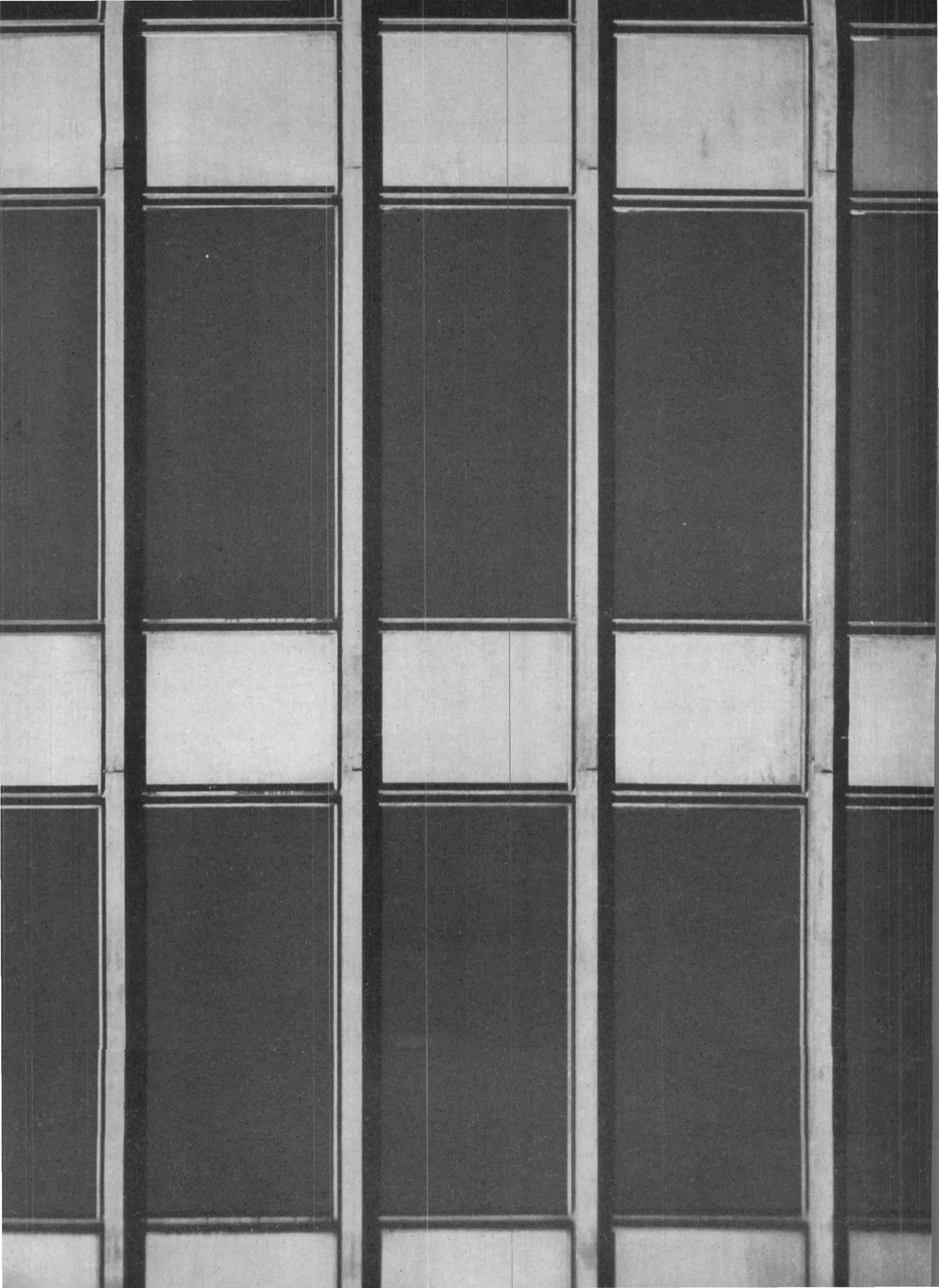

# THE HOUSE OF SEAGRAM

375 Park Ave., New York

This project is of especial interest for both its exterior and its plaza. The structural cage will be clad in statuary bronze and glazed floor to ceiling with pink-gray glass. The design for the plaza, 100 ft deep and a full blockfront wide, is still under study.

The 38 story building, costing more than 20 million, will provide 530,000 sq ft of office area, one-third of which Seagram will occupy. There will be underground parking. Completion date: late 1957. *Architects: Mies van der Rohe and Philip Johnson. Associate Architects: Kahn & Jacobs. General Contractors: George A. Fuller Company.*

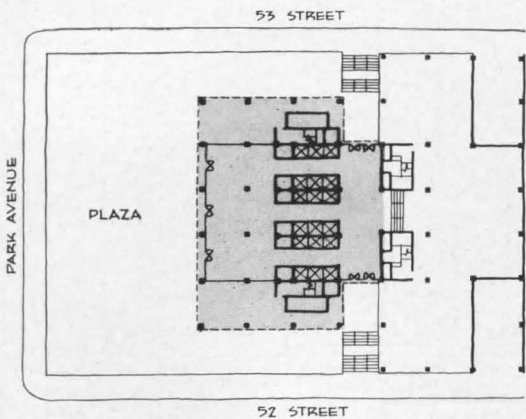
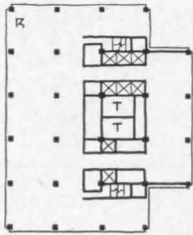

R - RENTAL  
T - TOILET



Joseph W. Molitor

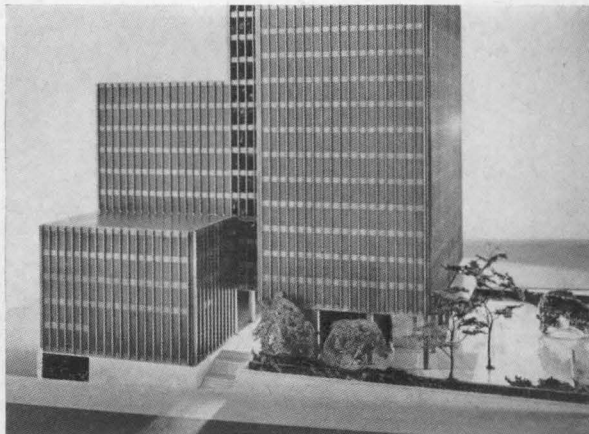
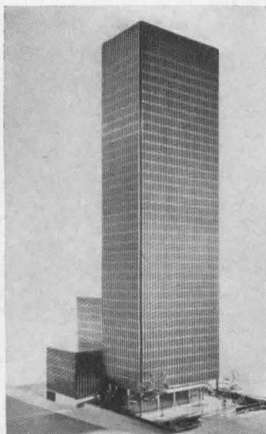

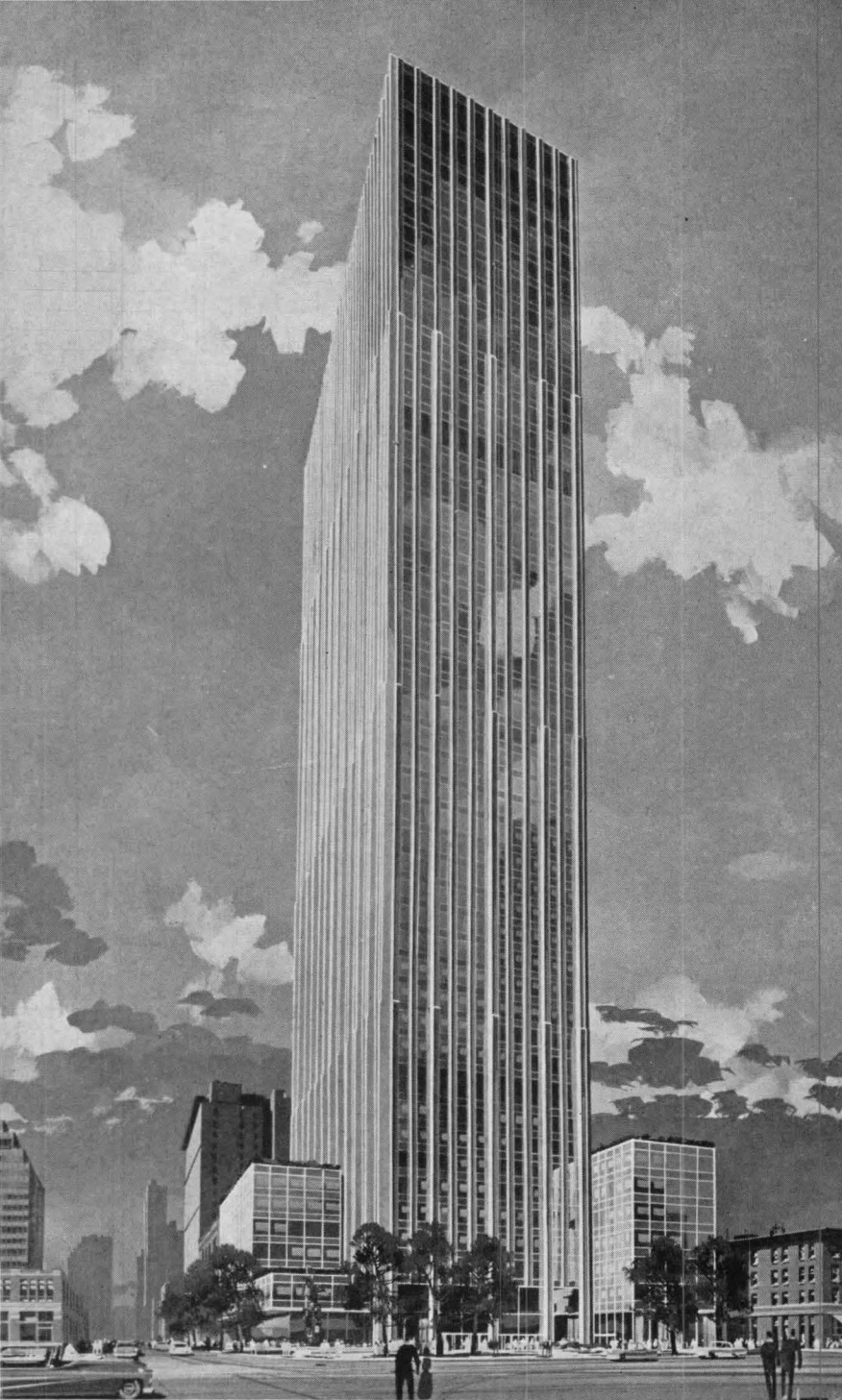

## TIME AND LIFE BUILDING

50th to 51st Sts., Sixth Ave., New York

Located opposite Radio City Music Hall and the newest addition to Rockefeller Center, this building, as the others, will provide an open plaza area; in this case 200 by 80 ft. Preliminary plans for that space envision trees, planting, pools, and sculpture for it.

The 70 million dollar building will rise 47 floors to a height of 550 ft above the 82,000 sq ft plot and provide 1,400,000 sq ft of office area. Time's 2000 employes will occupy 20 floors, or 600,000 sq ft on a 21 year renewal lease. *Architects: Harrison & Abramovitz. General Contractors: George A. Fuller Company and John Lowry.*

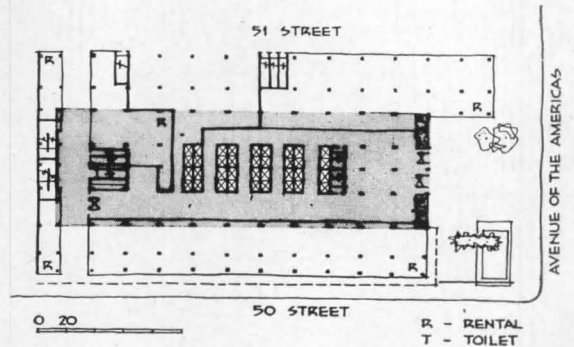
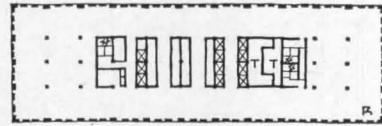

Left to right: Monadnock Block, Chicago, 1891, Burnham & Root; Home Insurance Building, Chicago, 1885, William LeBaron Jenney; Tacoma Building, Chicago, 1887, Holabird & Roche; Masonic Temple, Chicago, 1890, Burnham & Root



Hedrich-Blessing



Bettman Archive

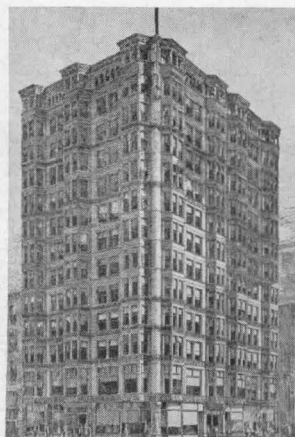

Bettman Archive



Bettman Archive

# ASTOR PLAZA BUILDING

53rd to 54th Sts., Park Avenue, New York

Located directly north of the new Seagram building and directly east of Lever House, this project — as they — will feature a landscaped plaza of considerable area. The interrelationship of the three high shafts and their open ground areas should provide a spatial complex of uncommon architectural interest.

The 60 million dollar metal and glass structure will cover practically an entire block and rise 42 stories to provide 1,000,000 sq ft of office area for an estimated 10,000 people. Underground parking for executives. *Architects: Carson & Lundin. General Contractor: George A. Fuller Company.*

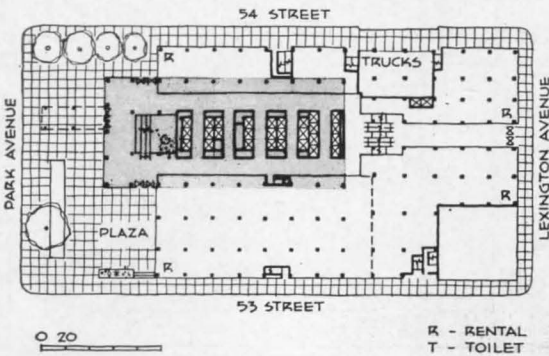
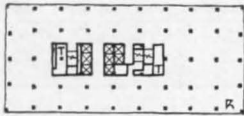

*Tower Building, New York, 1889, Bradford L. Gilbert; Auditorium Building, Chicago, 1889, Adler & Sullivan; Wainwright Building, St. Louis, 1891, Adler & Sullivan; Guaranty Trust Co. Building, Buffalo, 1895, Adler & Sullivan*



Arch. Record, 1891



Bettman Archive



Hedrich-Blessing



Len Gittleman, III



Gordon Sommers

### 3325 WILSHIRE BUILDING

*Wilshire and Catalina, Los Angeles*

Sun control exerted a heavy influence in the design of this structure's exterior. The east and west façades feature a system of outriggers, set 3 ft from the glass, which support vertical aluminum louvers tilted to exclude the sun and admit only north light. The north and south sides of the building are protected by horizontal louvers.

The building's 13 stories rise 150 ft (the height limit in Los Angeles) over a 20,720 sq ft plot to provide 213,000 sq ft of office area. Parking on 5 lower levels will handle 360 cars. *Architect: Victor Gruen Associates, Edgardo Contini, Structural Engineer.*

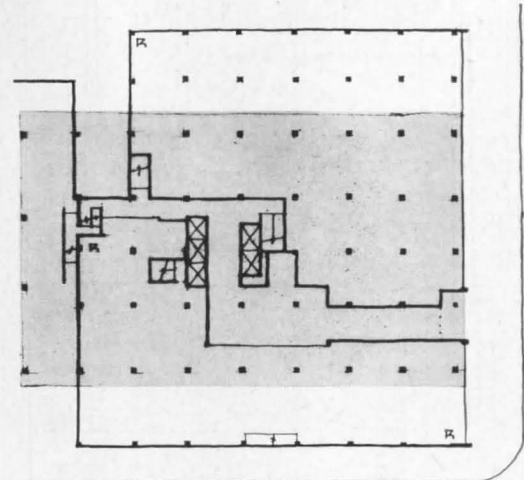
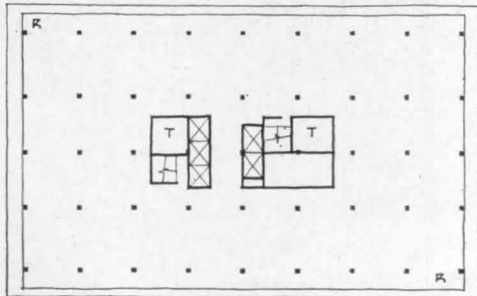

# CAPITOL RECORDS TOWER

*Vine & Yucca Sts., Hollywood, Cal.*

Contrary to the popular Hollywood belief that this building's cylindrical shape derives from a stack of records, architect Becket explains, "the circular plan stems from carefully evaluated economics and sound planning principles. The 90 ft circle requires 20 percent less outer wall and makes possible a smaller core than would an equal-area rectilinear shape."

The 2 million dollar structure's 13 floors rise 150 ft (the legal height limit) to provide 78,000 sq ft of office area. Off-street parking at the rear handles 95 cars. *Architect: Welton Becket & Associates. General Contractor: C. L. Peck Co.*

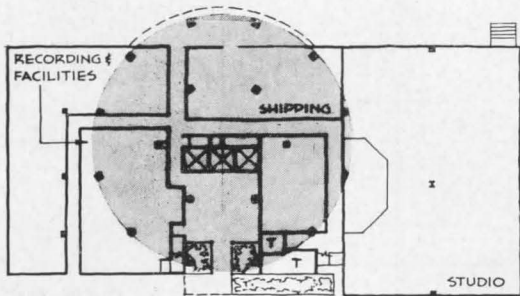
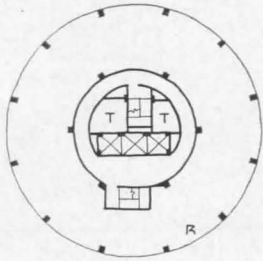

R - RENTAL  
T - TOILET



Herbert Bruce Cross

# BORG-WARNER BUILDING

200 South Michigan Ave., Chicago

The use of color will be an important exterior feature. The lightweight curtain-wall will be clad in dark blue porcelain enamel spandrel panels, which will contrast interestingly with the aluminum windows and mullions. The latter will be anodized in a natural satin finish.

The structure will rise 21 stories (of which Borg-Warner will occupy five) and provide a net office area of 362,300 sq ft out of a gross of 431,000 sq ft. Estimated population is 3000. Lower level parking will be provided. Completion date: early 1958. Architects & Engineers: A. Epstein & Sons. Consulting Architect: William Lescaze.

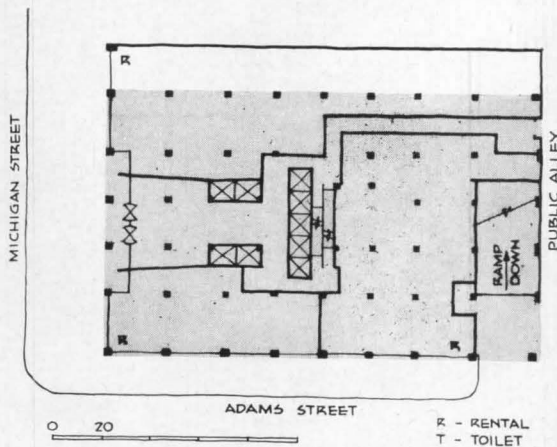
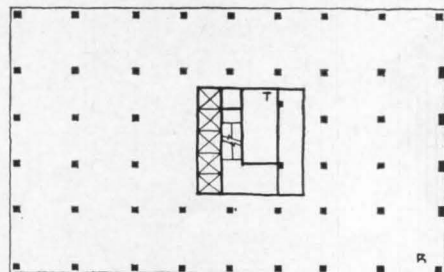

Left to right: Singer Building, New York, 1908, Ernest Flagg; Metropolitan Life Insurance Co. Tower, New York, 1909, N. LeBrun & Sons; Woolworth Building, New York, 1913, Cass Gilbert; New York City Municipal Building, 1919, McKim, Mead & White; The Tribune Tower as constructed, Chicago, 1922, Hood & Howells

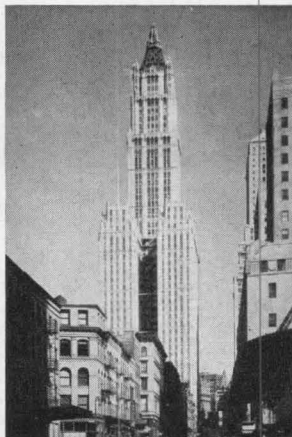

James S. Hornbeck



Wurts Brothers

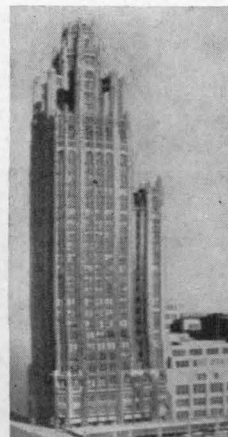

Chicago Tribune



# 666 FIFTH AVE. BUILDING

52nd to 53rd Sts., Fifth Ave., New York

This skyscraper will feature an anodized aluminum skin with patterned spandrel panels and 20 in. wide vertical column covers of white porcelain enamel. The 12 by 7½ ft units will be inside bolted. All structural steel will be bolted.

Acquisition of air rights over an adjacent library enabled the architects to increase the originally planned tower area by 4000 sq ft.

The building's 38 floors, rising on a 61,000 sq ft plot, will provide more than 1,000,000 sq ft of office space. Completion date: summer of 1957. Architects: Carson & Lundin. Owner & Contractor: Tishman Construction Co.

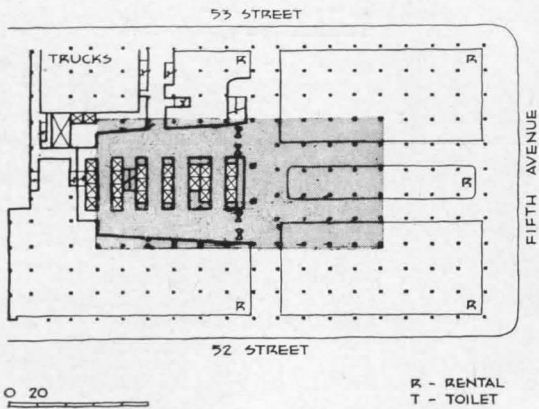
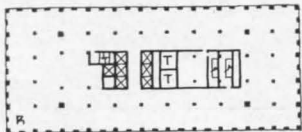
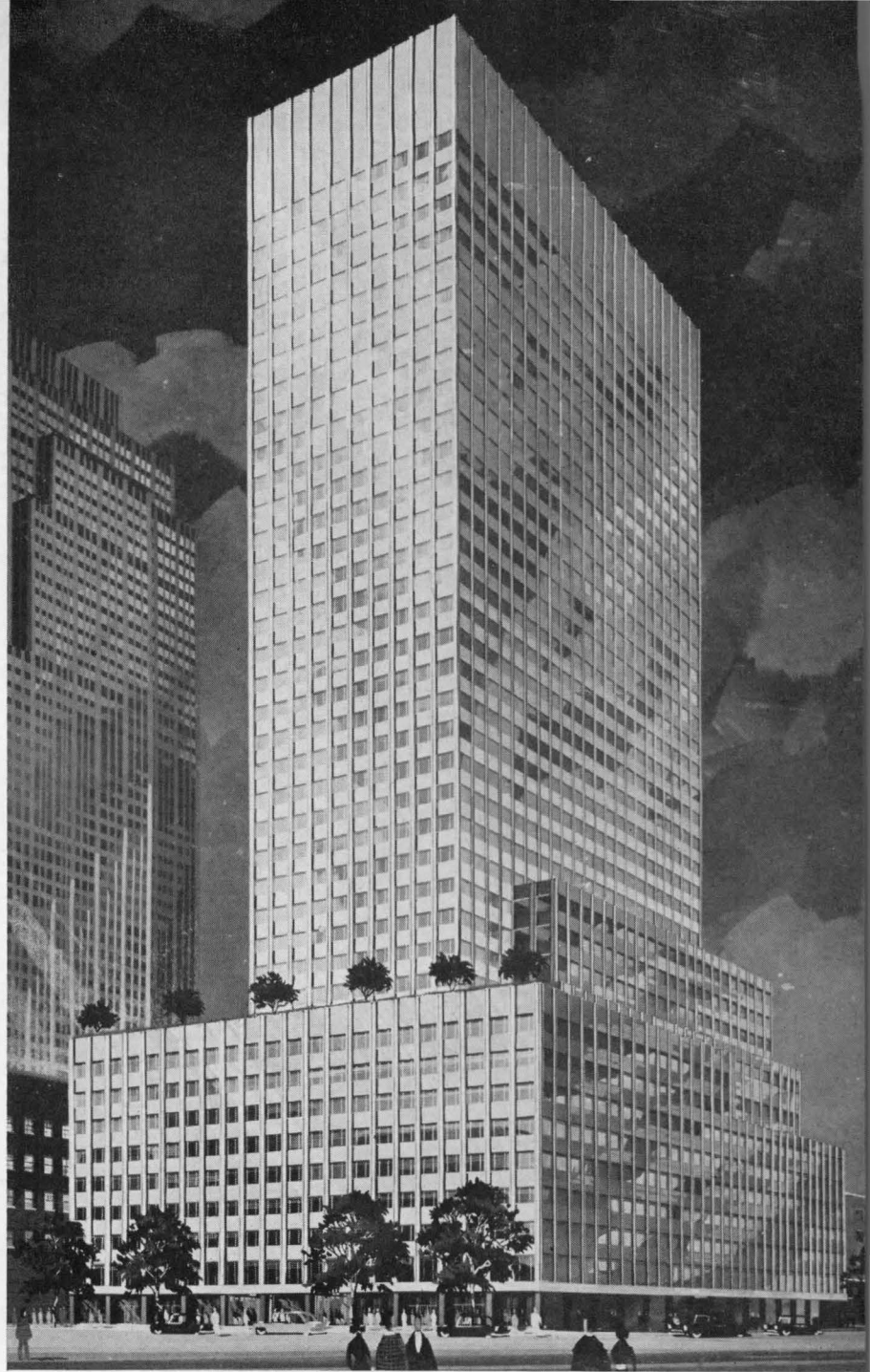

0 20

R - RENTAL  
T - TOILET

Left to right: Tribune Tower Project (placed second) by Eliel Saarinen, 1922; American Radiator Co. Building, New York, 1925, Raymond Hood; Wrigley Building, Chicago, south portion 1922, north portion 1925, Graham, Anderson, Probst & White; New York Central Railroad Office Building, New York, 1929, Warren & Wetmore



Chicago Tribune

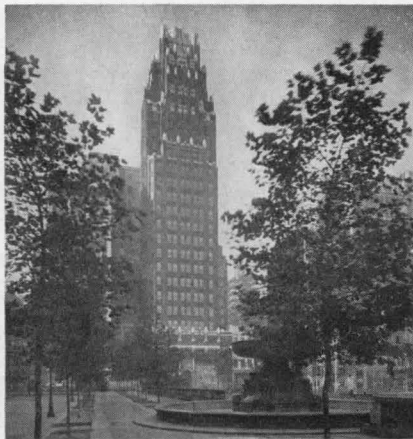

Samuel Gotscho



Chicago Arch Photo Co.

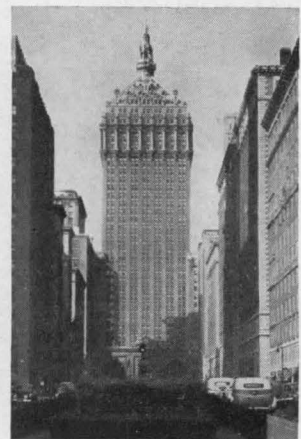

# SOCONY-MOBIL BUILDING

150 East 42nd St., New York

This building, the largest erected in New York for a quarter-century, is also the first skyscraper to be clad entirely in stainless steel. The panels are stamped in a pattern calculated to give them rigidity, reduce light reflection, and provide oblique vertical paths down which rain can wash.

The structure's 45 floors rise 567 ft above the two-acre plot and provide a net office area of 1,600,000 sq ft. Cost: about 37.5 million. Approximately 8000 people work in the building; 2500 of them for Socony-Mobil. *Architects: Harrison & Abramovitz. General Contractor: Turner Construction Company.*



Wurts Brothers

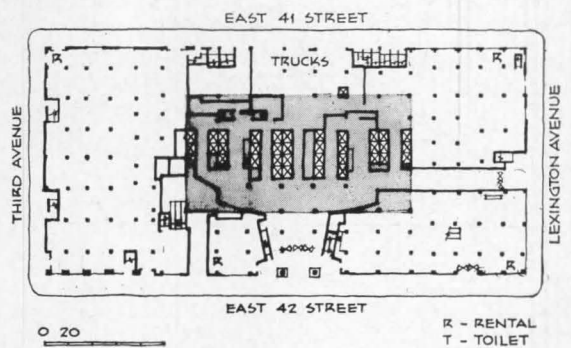
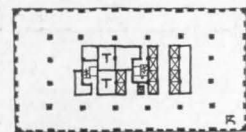

Wurts Brothers

Ezra Stoller





# CORNING "TOWER OF GLASS"

717 Fifth Ave., New York

This building will, needless to say, be sheathed in glass; the exterior grid will be aluminum, details of which are under study.

The tower will rise without setback from the avenue and will, as the plan shows, shoot upwards alongside a landscaped plaza (60 by 30 ft in size) that will "open up" the corner.

The structure's 28 stories, rising over a 30,000 sq ft plot, will provide a net office area of 365,000 sq ft, most of which will be occupied by the Corning Company. Completion date: late 1958. Architects: Harrison & Abramovitz & Abbe. General Contractor: George A. Fuller Company.

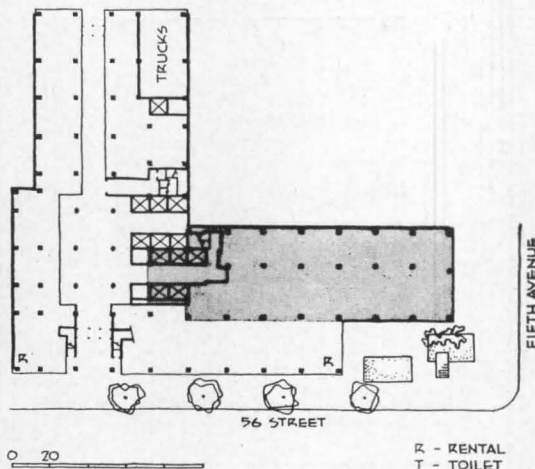
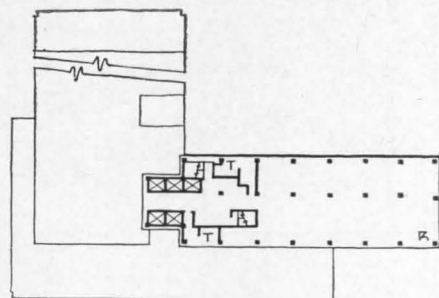

Left to right: Telephone Building, New York, 1926, McKenzie, Voorhees & Gmelin; Fisher Building, Detroit, 1928, Albert Kahn & Associates; Board of Trade Building, Chicago, 1930, Holabird & Root; Empire State Building, New York, 1929, Shreve, Lamb & Harmon; Irving Trust Company Building, New York, 1930, Voorhees, Gmelin & Walker



Sigurd Fischer



Hedrich-Blessing

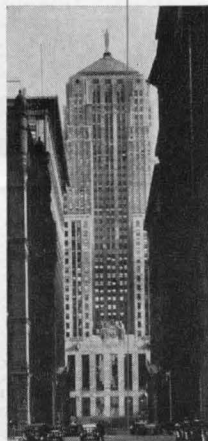

Chicago Arch Photo Co.

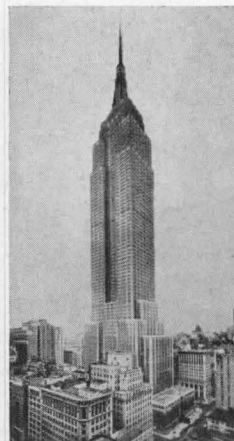

N. Y. Times



# ILLUMINATING BUILDING

55 Public Square, Cleveland

This handsome shaft is the first tall building to rise in downtown Cleveland since 1930, and also the first in that city to be set in an extensive (250 by 55 ft) landscaped plaza. The smart, shimmering tower and its developed setting should have a salutary effect upon the architectural scene in Cleveland.

The structure's 22 floors will provide a net area of more than 400,000 sq ft of office space, enclosed in a curtain wall of aluminum and glass. An adjacent ramp garage will provide parking for over 400 cars. *Architects: Carson & Lundin. General Contractor: George A. Fuller Company.*

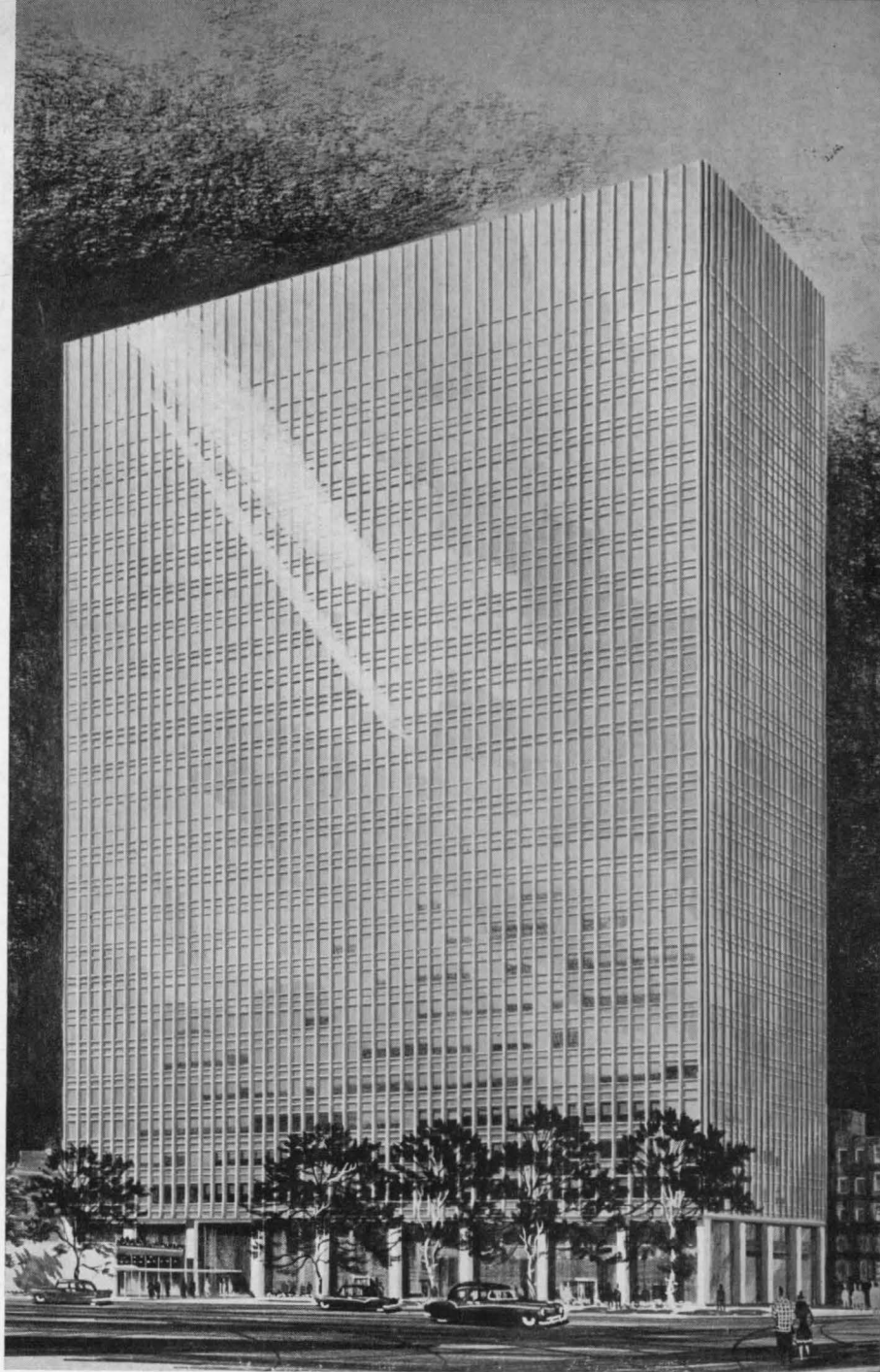
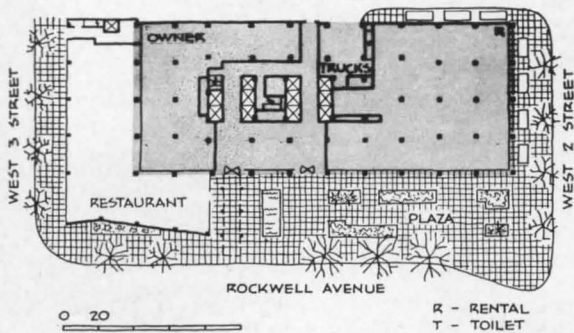
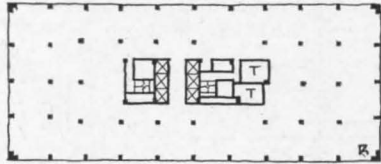

Left to right: Chrysler Building, New York, 1930, William Van Alen; Daily News Building, New York, 1930, Hood & Howells; Rockefeller Center, New York, 1930's, Reinhard & Hofmeister; Corbett, Harrison & MacMurray; Hood & Foulhoux; McGraw Hill Building, New York, 1931, Hood, Godley & Foulhoux; Savings Fund Society Building, Philadelphia, 1932, Howe & Lescaze

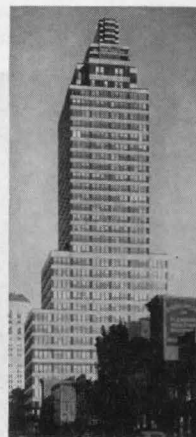
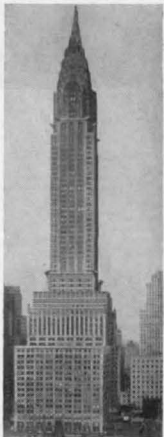

Joseph W. Molitor

Edward Ratcliff

James S. Hornbeck

# FORD OFFICE BUILDING

*The American Road, Dearborn, Michigan*

This attractive administrative headquarters building features, among other things, a curtain wall of insulated porcelain-enamel faced panels with aluminum surrounds and blue-green heat absorbing glass. The building includes extensive areas for company central staff services as well as space for offices.

The building's 12 floors rise 200 ft above the 90-acre landscaped plot to provide a net office area of 950,000 sq ft for 3100 Ford employees. Parking facilities: Three parking lots take 2300 cars; the indoor garage 320. *Architects: Skidmore, Owings & Merrill. General Contractor: Bryant & DeWeiler Company.*



Ezra Stoller

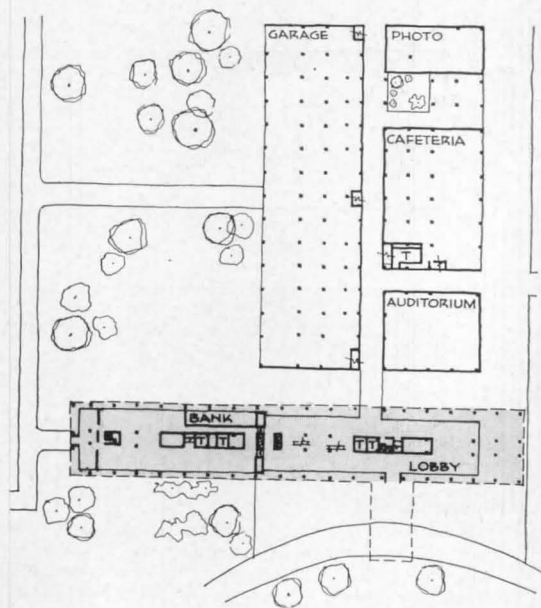
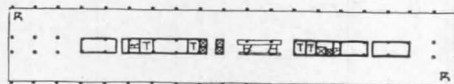

0 20

R - RENTAL  
T - TOILET



# THE H. C. BECK BUILDING

*Travis at Edwards Sts., Shreveport*

This building adds a smart new dash of color to the Shreveport skyline. The lightweight curtain-wall is sheathed in anodized aluminum elements: blue spandrel panels; light gray column coverings; satin aluminum windows and mullions. A public, multi-denominational chapel which can seat 60 persons is an interesting departure from the commercial norm.

The structure's 20 stories rise over an 80 by 150 ft downtown plot to provide a net office area of 195,000 sq ft out of a gross of 260,000. Nearby off-street parking is available. *Architects: Neild-Somdal-Associates. Owner and General Contractor: Henry C. Beck Company.*

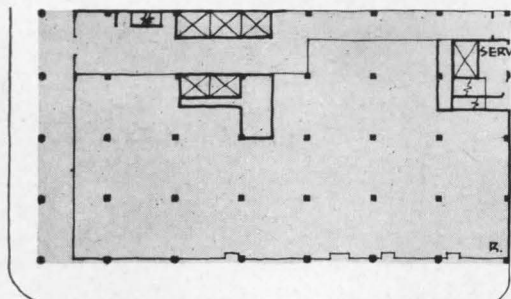
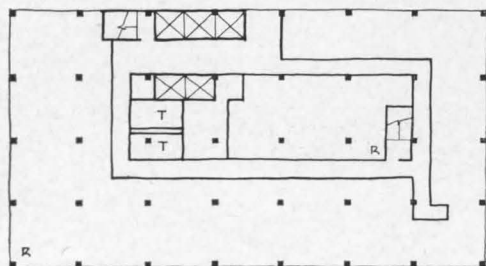

R - RENTAL  
S - SERVICE  
T - TOILET



Thurman C. Smith

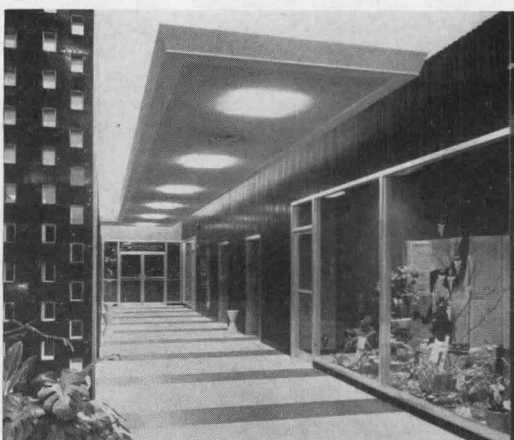

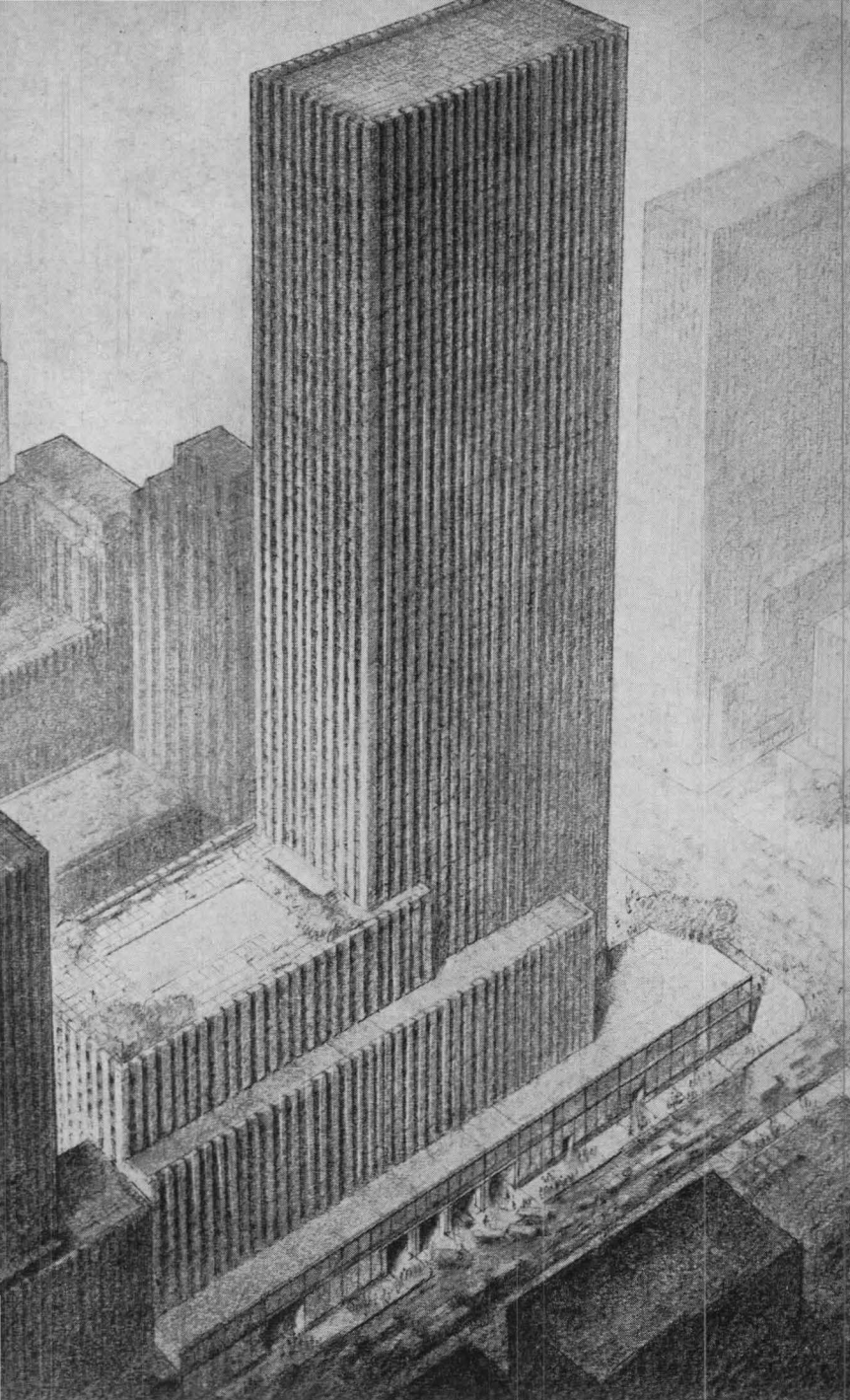

### 33 WEST 51st ST. BUILDING

51st to 52nd Sts., Sixth Avenue, New York

This giant will be sheathed in stainless steel, as is the Socony building (see p. 238) — and upon completion will become the largest structure in the world so clad.

Further features: tower floors 15 through 60 will be entirely free of interior columns; the main mass will be set 40 ft back from the avenue to provide a "plaza forecourt."

The structure's 60 floors will rise 775 ft on a 100,000 sq ft plot to provide 1,700,000 sq ft of office area for approximately 10,000 people. Cost: 50-60 million. Completion: early 1960. Architects: Harrison & Abramovitz. Contractor: Turner Construction Company.

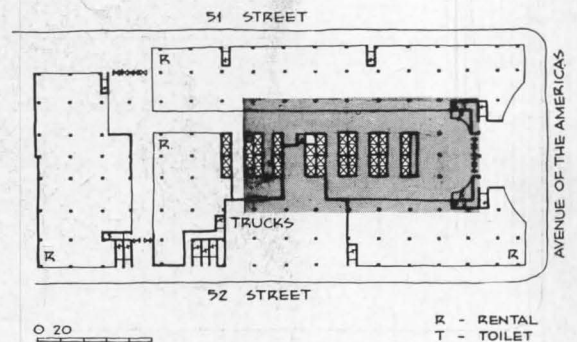

Left to right: Longfellow Building, Washington, D. C., 1941, William Lescaze; Equitable Building, Portland, 1948, Pietro Belluschi; Esso Building, New York, 1948, Carson & Lundin; Prudential Building, Los Angeles, 1948, Welton Beckel & Associates



Ezra Stoller

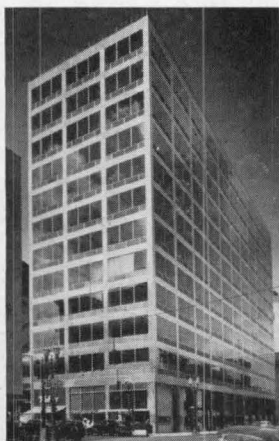

Ezra Stoller

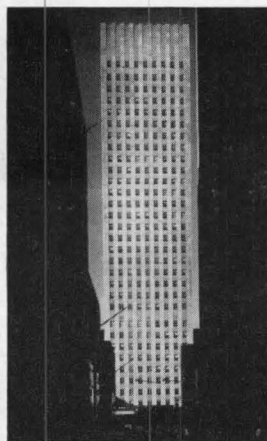

Ezra Stoller



Douglas M. Simmonds



# SOUTHLAND LIFE BUILDING

*Live Oak, Pearl, Bryan & Olive Sts., Dallas*

This striking complex, to be known as "Southland Center," will eventually comprise two office buildings and a 28 story, 600 room hotel, with gardens, arcades, and shops at ground level. The large building and hotel are under way; foundations for remainder are in place.

The 45 story, 25 million dollar central mass will rise 550 ft above the 100,000 sq ft plot and provide a net office area of 400,000 sq ft. Southland Life will occupy 18 floors. A four-level basement garage will park 2000 cars. Completion date for the first stage: late 1958. *Architects: Welton Beckel & Associates. Consulting Architect: Mark Lemmon.*

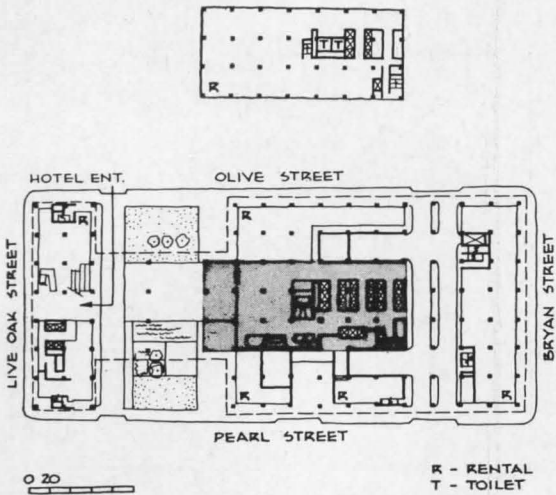
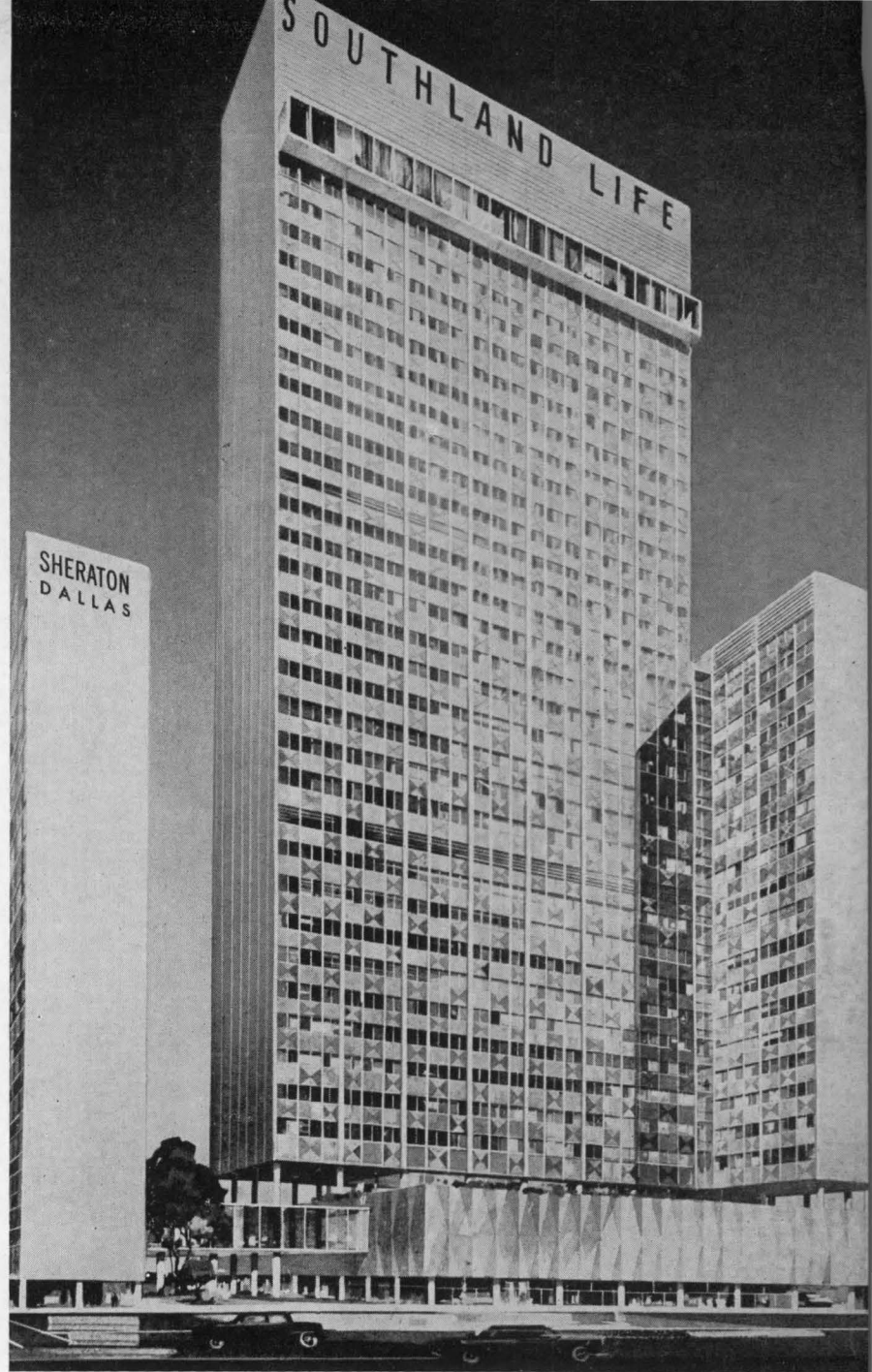

*U.N. Secretariat, New York, 1950, Wallace K. Harrison, Director of Planning; First National Building, Tulsa, 1950, Carson & Lundin; Mellon-U. S. Steel Building, Pittsburgh, 1952, Harrison & Abramovitz; Lever House, New York, 1952, Skidmore, Owings & Merrill*

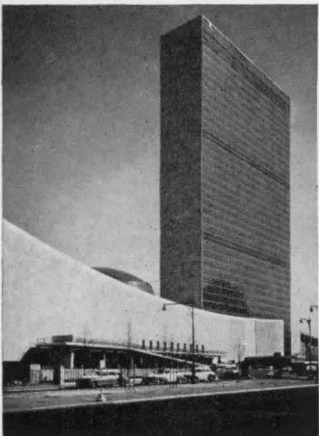

Joseph W. Molitor



Ezra Stoller



Wurts Brothers



Joseph W. Mallor

## 711 THIRD AVENUE BLDG.

44th to 45th St., New York

Enlightened clients enabled architect Lescaze to lift this speculative building out of the class of Gotham's rampant zigguratism. Ways and means: trading a reduced cube for a cleaner, simpler tower two floors higher; colorful brick exterior — blue tower, white mid-platform, gray base; Hans Hoffman mosaic and Jose de Rivera sculpture for the lobby.

The structure's 19 floors provide a net rentable area of 400,000 sq ft — 372,000 of which is above the first floor. Basement parking is provided. Architect: William Lescaze. Owners — builders: William Kaufman, J. D. Weiler & B. H. Swig.

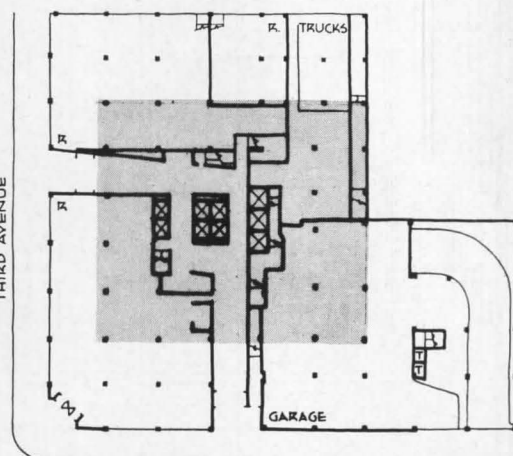
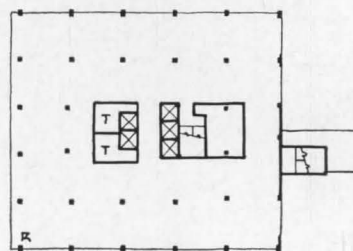

THIRD AVENUE  
EAST 44 STREET  
0 20  
R - RENTAL  
T - TOILET

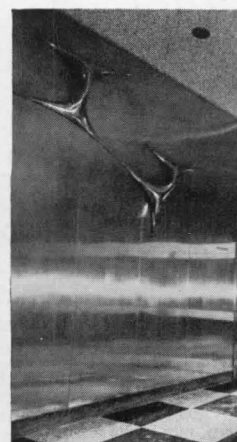
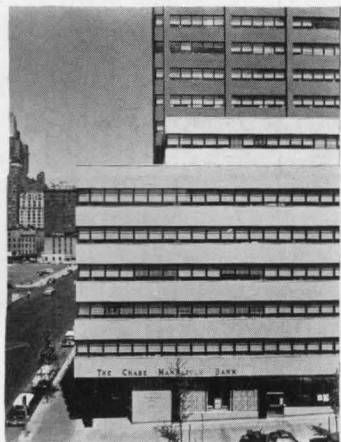

# PITTSBURGH STATE OFFICE BUILDING

*Point Park, Pittsburgh*

This building, constructed with funds allocated by The General State Authority, a separate corporation of the Commonwealth of Pennsylvania, was one of the first to use colored anodized aluminum for its exterior. The panels are blue; the overlay grid natural aluminum.

The 16-floor structure covers 47 percent of the 54,800 sq ft plot and provides an area of 295,000 sq ft, 80 percent of which is rentable. Cost, including partitions: under 6 million. Complete occupancy: spring of 1957. Architects: *Allenhof and Bown*.

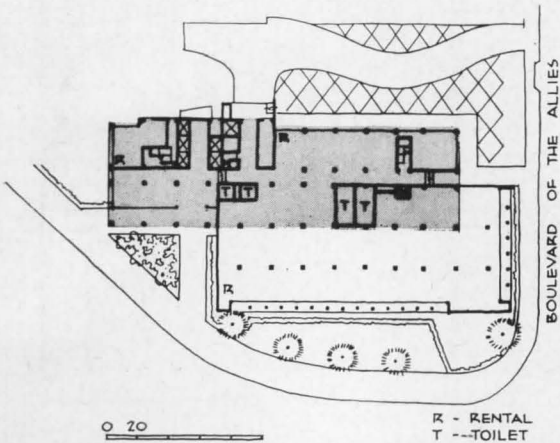
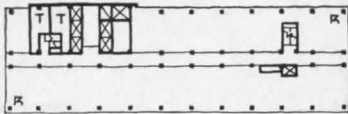

A. Church



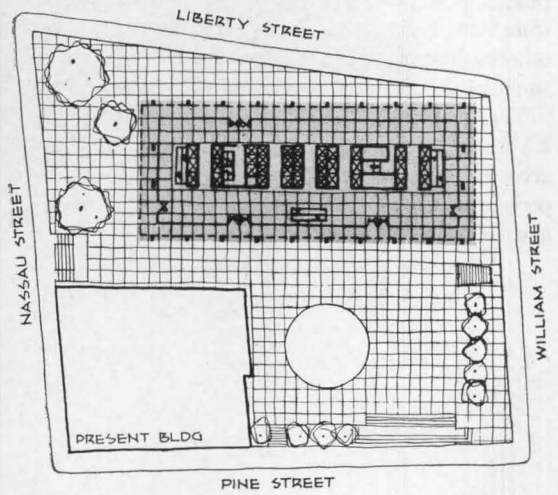
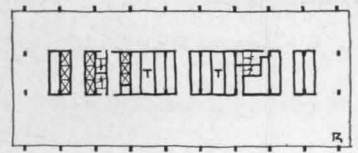
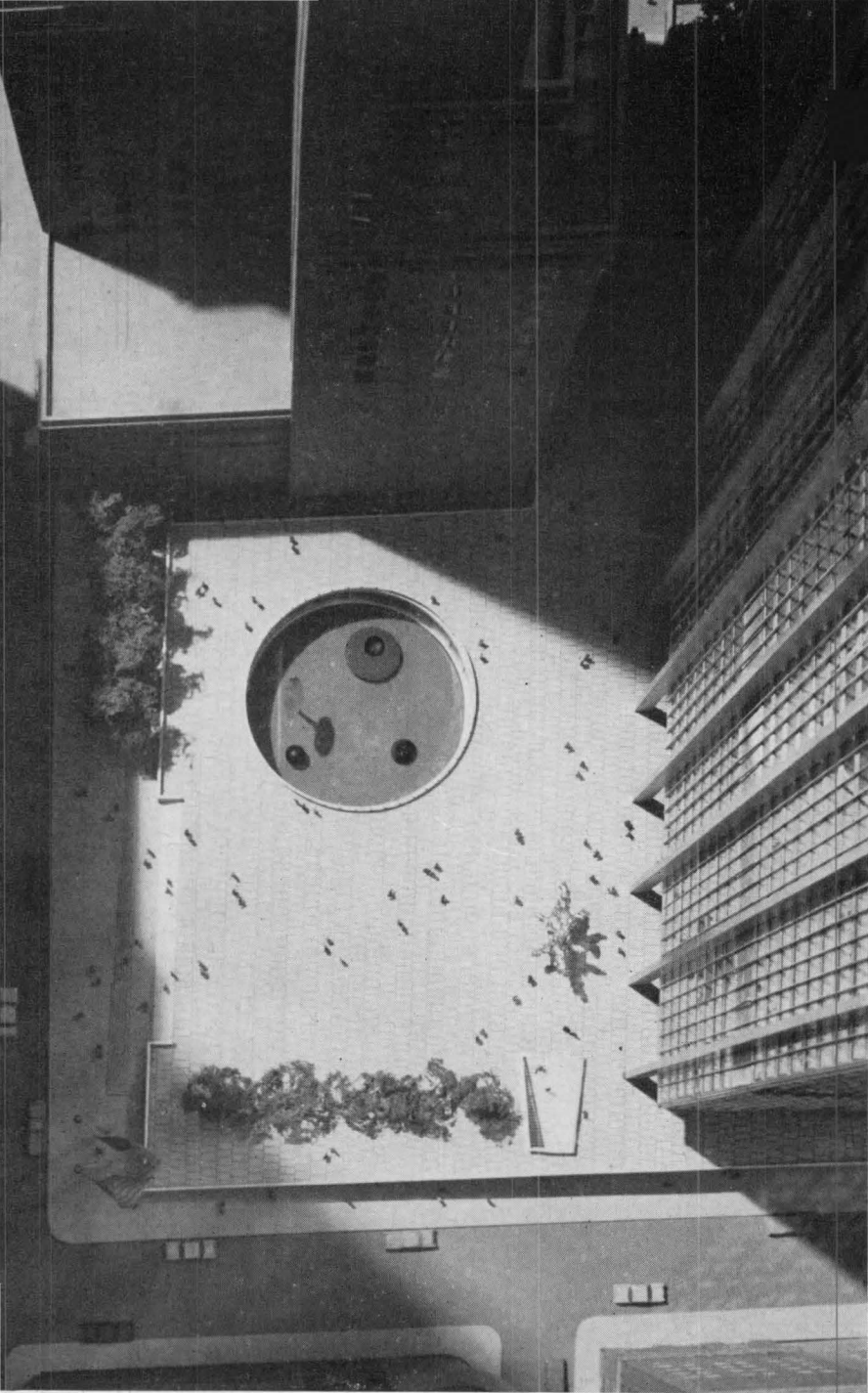

R - RENTAL  
T - TOILET

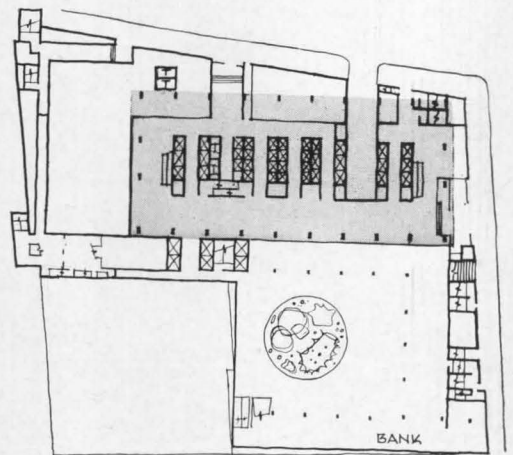

Left to right: Alcoa Building, Pittsburgh, 1952, Harrison & Abramovitz; Standard Federal, Los Angeles, 1953, Welton Becket & Associates; Mile High Center, Denver, 1955, I. M. Pei & Associates; Prudential Building, Jacksonville, 1955, Kemp, Bunch & Jackson



Jack D. Mahony



Douglas M. Simmonds

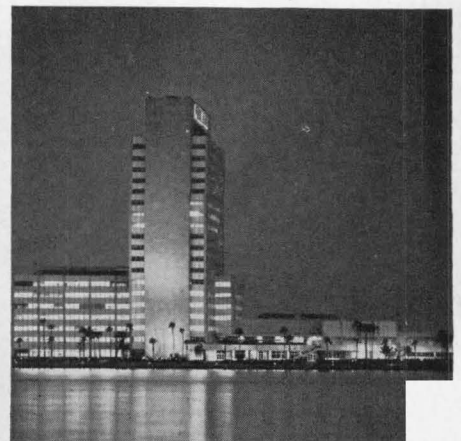

Bodden Photos

# CHASE MANHATTAN BANK

*Liberty & Williams Sts., New York*

This imaginative project will make the first significant break in the canyon-like pattern of downtown New York by devoting 70 percent of its two-block site to an open plaza. A glistening metal and glass office shaft — its verticality emphasized by outer columns — will soar skyward from the man-made spread of the platform, otherwise punctured principally by the circular sunken garden for the bank below.

The tower's 60 floors will rise 815 ft above the 2.5 acre (113,000 sq ft) plot and provide 2,265,000 gross sq ft of office space for approximately 15,000 persons. Occupancy: early 1960. *Architects: Skidmore, Owings & Merrill*

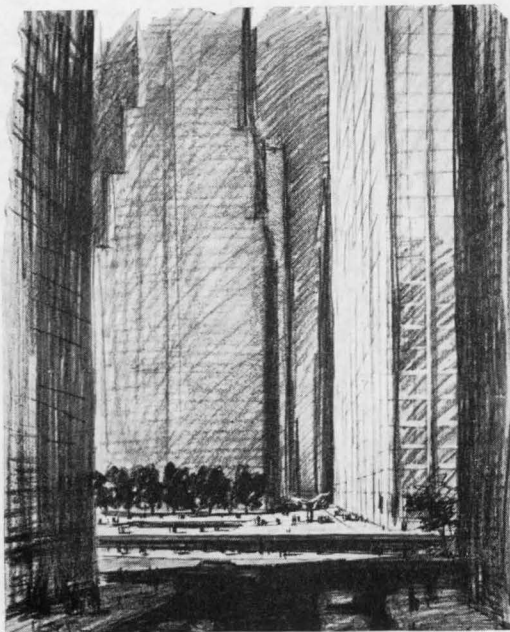

*Left to right: Republic National Bank, Dallas, 1955, Harrison & Abramovitz; Gill & Harrell; Prudential Building, Chicago, 1956, Naess & Murphy; Lutheran Brotherhood, Minneapolis, 1956, Perkins & Will; Price Tower, Bartlesville, 1956, Frank Lloyd Wright*



Ulric Meisel

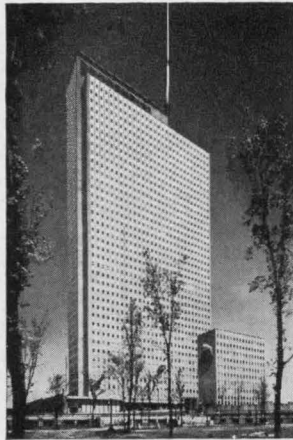

Chicago Arch Photo Co



Hedrich-Blessing



Joe Price

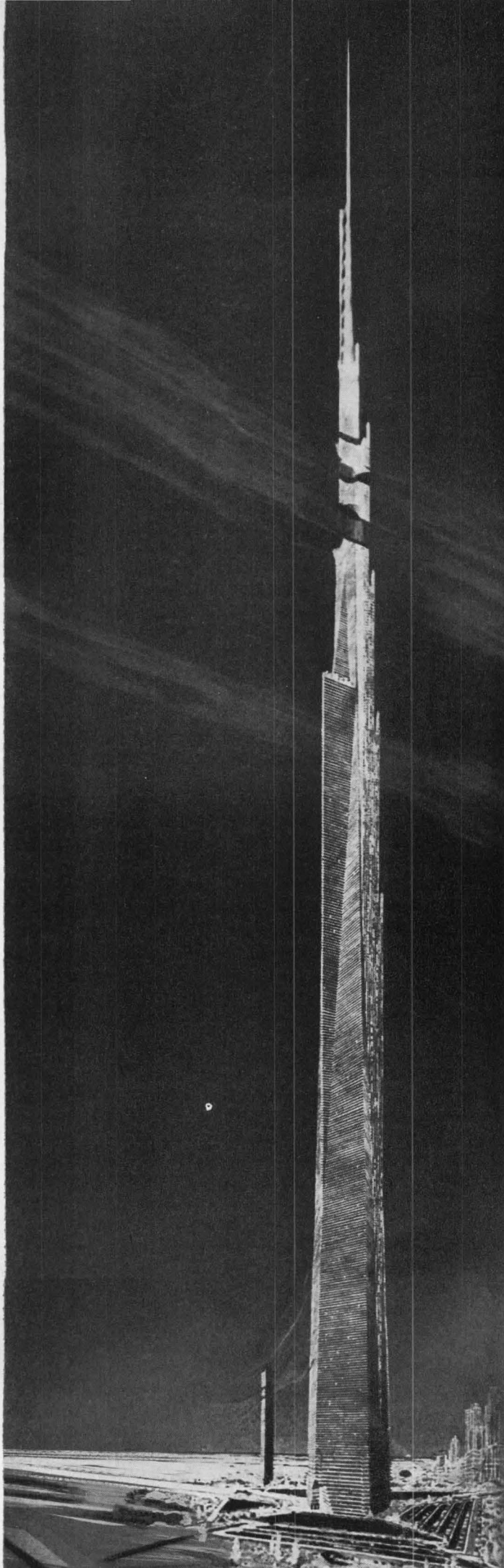

## THE MILE HIGH ILLINOIS

Frank Lloyd Wright's recently publicized \* design for a "cantilever sky-city" is large in scope, daring in concept, and hauntingly provocative. One is forever confounded by the apparently limitless range of Wright's creativity.

The project's unveiling gave architects — and others — a great deal to ponder. There has been comment and discussion, pro and con, thoughtful and derisive. The inevitable "could it actually be built?" was asked.

But whether or not The Illinois is ever built is beside the point that for 60 years Wright has shown a talent for stirring up controversy; and such controversies almost invariably work to gain wide hearing for his ideas. In this fashion Wright continues to stimulate fresh architectural thinking and new directions in design.

Does this approach to the skyscraper hold portents for the future office building?

\* *Architectural Record*, Nov. 1956, p. 11.



Werner Sloy

## A NEW WRINKLE IN STRESSED-SKIN

**Aluminum panels pleated for strength  
— and an exciting pattern**

*An aluminum dome recently built at Hawaiian Village in Honolulu will serve as a convention hall seating 2000 people. Rising almost fifty feet at its highest point, it spans 145 ft with no interior columns. It is  $\frac{1}{16}$  in. thick.*

**T**AKING A LEAF from the aerodynamicist's notebook, engineers of the Kaiser Aluminum & Chemical Corporation have fashioned thin aluminum sheets into rigid panels which combine to form a stressed-skin shell capable of resisting winds up to twice hurricane force. The diamond-shaped panels, proportioned in ten different sizes according to their position in the dome, are strengthened by six bends radiating from each end and intersecting in an intricate sunburst pattern. An aluminum strut, bridging the lengthwise valley created by this network of radial bends, makes each panel a strong structural unit, with loads equally divided between the panel and the strut.

These curved and stiffened aluminum segments are

geometrically arranged and fit together jig-saw fashion to mold the spherical surface of the dome. Where the corners of the panels converge, they are connected with specially-designed castings that disperse the loads through the shell to aluminum pipe struts used to anchor the dome to its foundation. The dual use of the aluminum panels as skin and framing members produces a strong, lightweight shell in which a minimum of materials gives a maximum of usable space.

The repetition of the same easily-joined basic units throughout also made it possible for the erection crew to assemble the dome in a matter of hours, without benefit of previous experience with a similar structure. Only 20 hours after the first panel was placed, the dome was ready to be anchored to its foundation.

The dome components — panels, struts and castings — were fabricated at a Kaiser plant in California. Before being shipped to the Hawaiian Village site, the 575 aluminum panels, which vary in length from 106 to

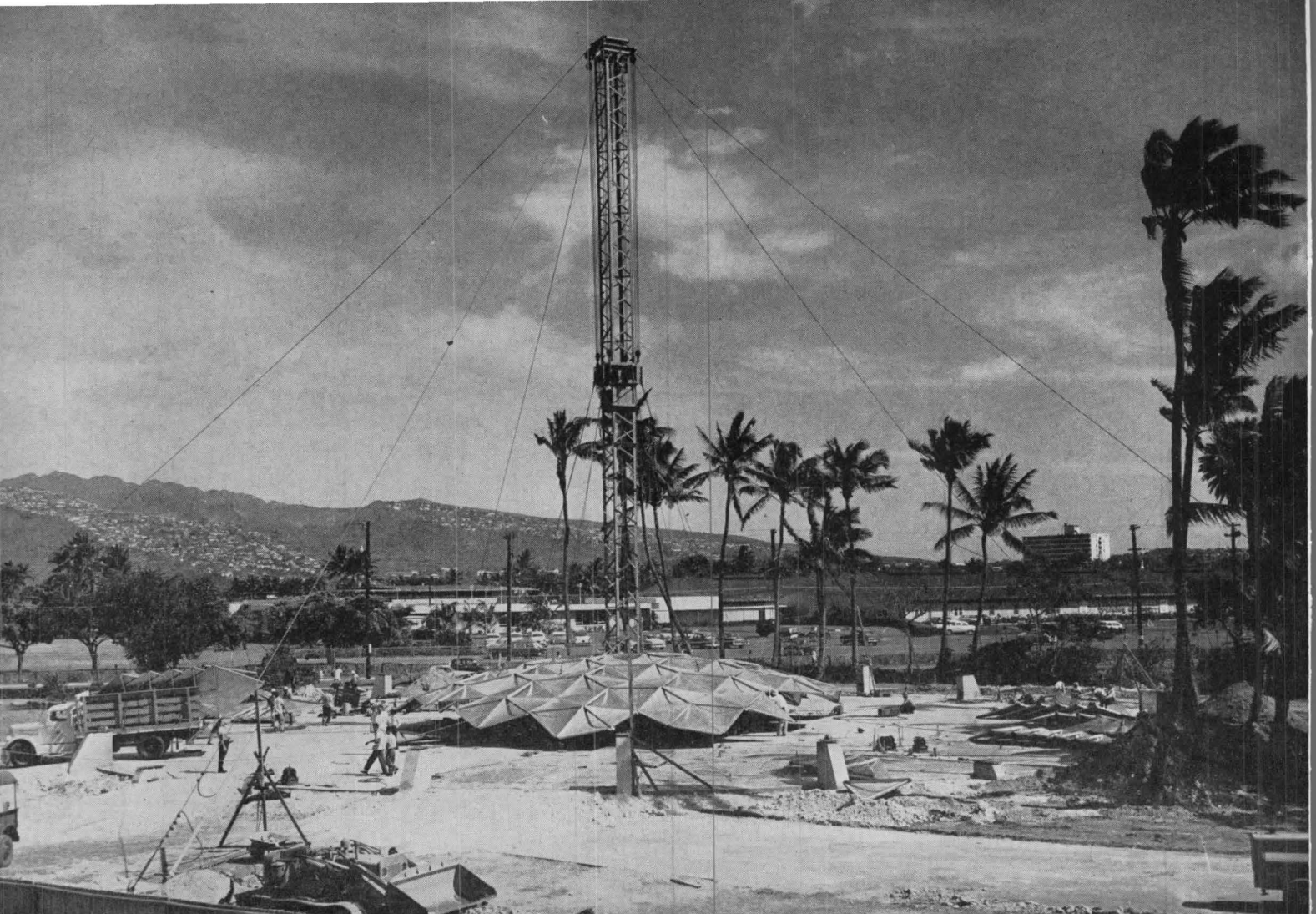

140 in. and in width from 65 to 82 in., were color-coded with a dab of paint on each to assure proper positioning in the dome. The panels and struts were formed without special dies, on a standard press brake. The precision with which they were made, plus the inherent stiffness of the panels themselves, was demonstrated later, by a settlement of only  $\frac{3}{4}$  in. in the completed dome.

Upon their arrival in Honolulu, the panels and struts were assembled, and trucked to the dome site where a demountable structural steel mast 96 ft tall had been set up in the center of the dome's concrete foundation.

Around this mast were assembled the panels which form the uppermost portion of the finished dome. When this section had been bolted together, it was raised high enough to allow another perimeter of panels to be installed. These in turn were bolted together, the larger section lifted, a third set of panels assembled — and so on until all the panels were in place.

For assembly, the dome was divided into five segments, with a five-man crew for each. Three of the men positioned the panels and joined them to the castings; the other two bolted adjacent panels together through

Werner Stoy

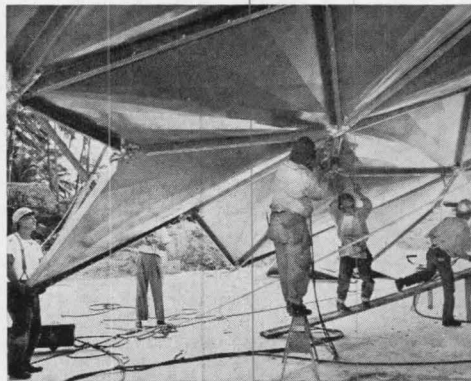



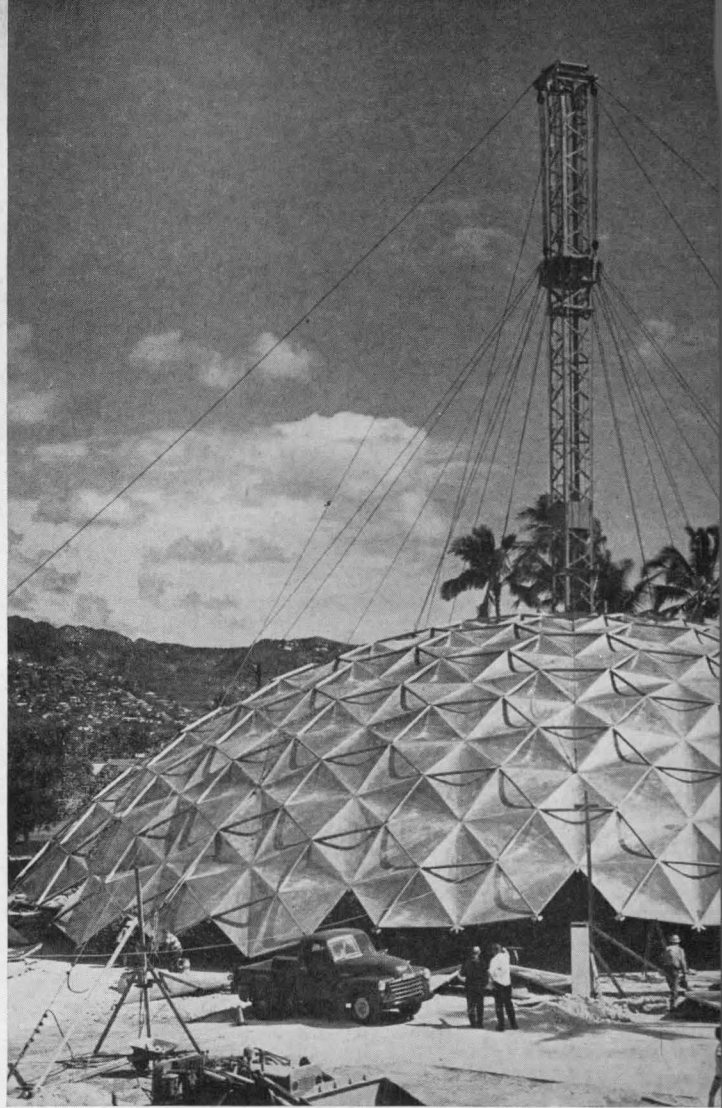
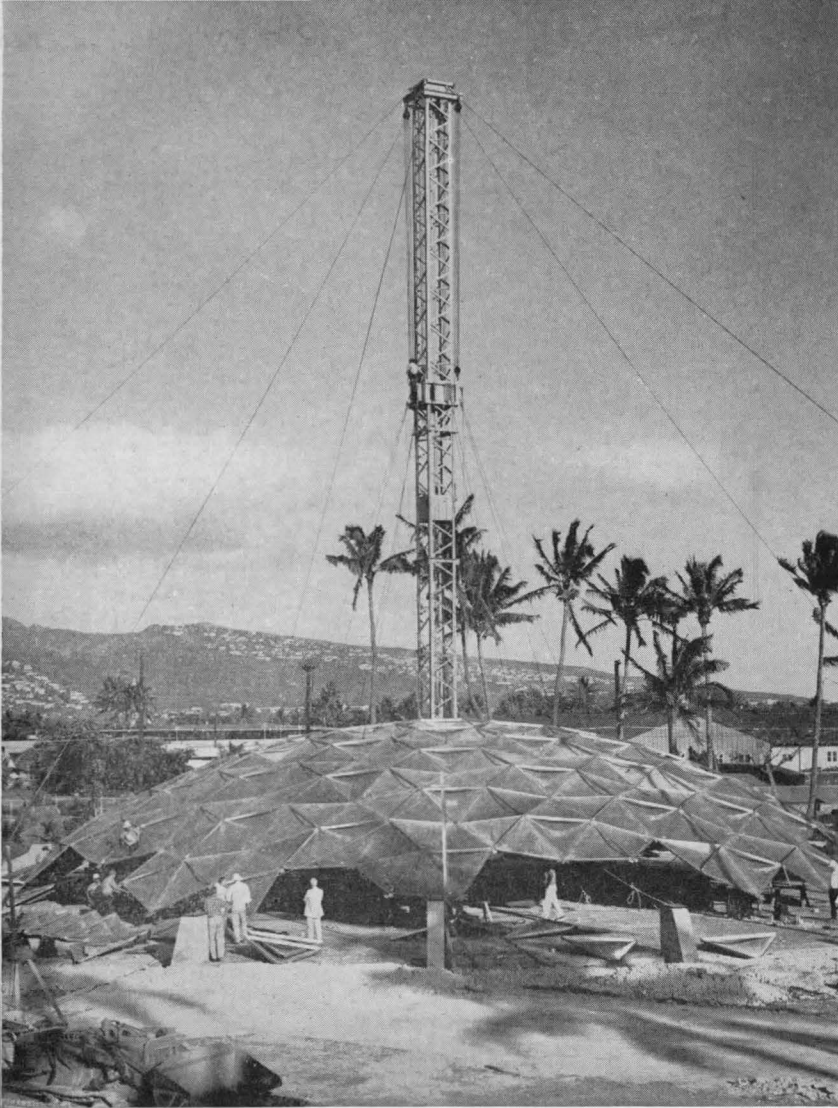

$\frac{3}{4}$  in. flanges along their outer edges to form a rigid shell. At those points where six of the "diamonds" converged, their ends were slipped over the prongs of star-shaped gusset castings and held in place with drift pins until they were bolted, while at the obtuse-angle corners of the panels the hub castings used to fasten the struts to the panels were simply fitted together and joined. All connections were made with special aluminum lockbolts to obtain a permanent high-strength union.

When the dome had been completely assembled and

lifted, it was lined up with concrete piers spaced at equal intervals round its circumference, and anchored to them with aluminum struts. These piers, from 18 to 65 in. high, reach down 6 ft to a coral base, providing firm anchorage for the dome. The  $2\frac{1}{2}$  in. pipe struts extending from each pier to the nearest gusset casting are connected at their base with pinned end connections to accommodate the 3 in. expansion and contraction of the dome. Rotary movement was prevented by placing the tips of the base panels in a track.

The anchorage of the dome completed, the portable

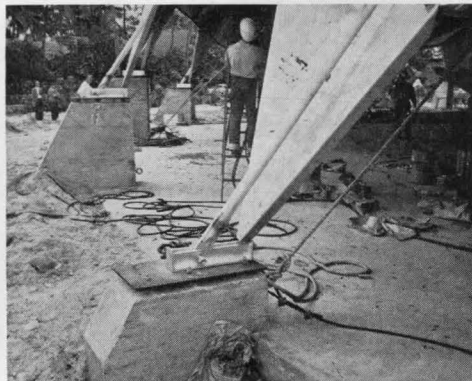
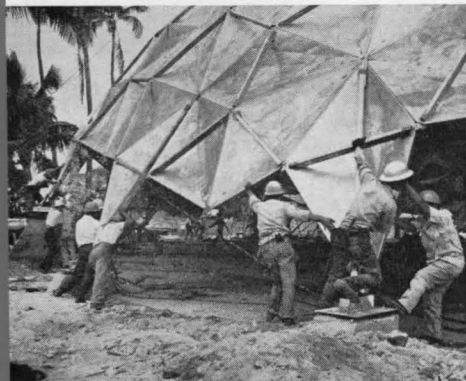

*The stressed-skin aluminum dome of the Hawaiian Village convention hall was assembled in sections around a steel mast and hoisted with hand winches. Erection crews of the Terminal Steel Company of Honolulu fit the panels into place like a jigsaw puzzle, then bolted them to castings and adjacent panels. To anchor the completed dome, base struts extend from concrete piers to the nearest gusset casting. Erection time: 20 hours.*



Werner Stoy

mast and rigging were removed and the exterior surface caulked along the joints between panels with a special sealing compound. A permanent overlapping cover of five aluminum panels was also placed over the 50 sq-ft opening left at the top of the dome. This elevated cap permits exhausting of air through the opening, forming what is in effect a built-in ventilating system.

Interior work on the convention hall involved only the construction of concrete walls at several of the openings to provide for a stage and other facilities, and the treatment for sound.

According to acoustical consultants Bolt, Beranek and Newman, the convention hall is expected to present no difficult acoustical problems. The large curved segments will in themselves provide better acoustics than would a smooth spherical surface, and the use of a sound amplifying system will further reduce the need for special sound control devices. Only  $\frac{1}{3}$  of the interior surface will be treated, the acoustical material being applied directly to the panels to retain their geometric pattern while supplying alternate hard and soft sounding surfaces.

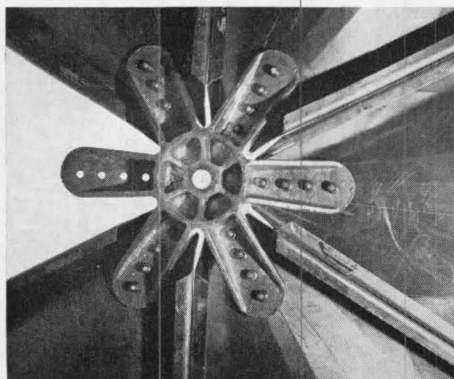
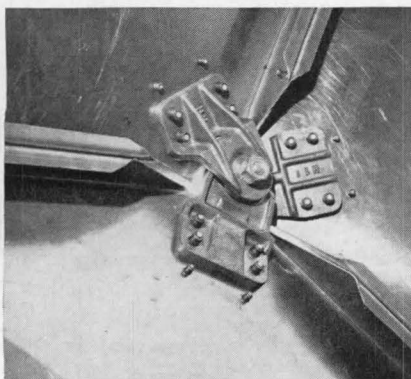

Aluminum hub castings (far left) fasten struts to panels, are bolted together during assembly. Star-shaped castings join tips of six converging panels.

# SOUND SYSTEMS

## Article 1: Fundamentals of equipment operation and selection

By J. F. McPARTLAND, Jr.

Engineering Editor, Electrical Construction and Maintenance

**B**ASICALLY a sound system is a hookup of several pieces of equipment to perform the functions of paging, public address, announcing and/or music distribution. Any sound system can be divided into three categories of equipment: (1) the signal source device, which provides sound in the form of an electrical signal to (2) the amplifier equipment, which strengthens the signal and modifies its characteristics and then delivers it to (3) the system loudspeakers, which convert the electrical signal into sound waves.

### System Components

Typical sound system input (signal source) devices are:

- (1) *Microphones*
- (2) *Radio tuner*
- (3) *Record or tape player*

(4) *Tone generator* (produces the electrical signal equivalent of a tone used for fire and other alarm signals, or of the sound of church bells or chimes.)

Functionally the amplifier equipment may be divided into two sections: the preamplifier and the power or booster amplifier. The preamplifier section provides some strengthening of the signal delivered by the system input device. It also equalizes the signal for tonal balance and provides for any desired intermixing of several signals, such as singing voice coming from one microphone on a stage and orchestra music coming from other microphones. Adjustments in volume and tone of the sound output from system loudspeakers are still other functions provided by the controls on the preamplifier section.

A signal, after modification in the preamplifier section, is fed into the power or booster amplifier. Here it is greatly strengthened, enabling it to make long runs in cables to the system loudspeakers so the sound output of each is loud enough for the area to be covered. Booster amplifiers are available in many sizes to meet the power require-

ments of a few or many loudspeakers in any type of system. Booster amplifiers can be operated in parallel to obtain power outputs which are multiples of the power of a single amplifier.

Physically, the arrangement of preamplifier and booster amplifier(s) may vary widely. By far the largest number of sound systems have both the preamplifier and booster amplifier on a single chassis. In custom-assembled console or cabinet rack mounting of amplifier equipment, the preamplifier and booster amplifier(s) are on individual chassis, but mounted close to each other. Sometimes, however, booster amplifiers are installed remote from their associated preamplifier, such as in another room or in outlying buildings from a main building in which the preamplifier and input devices are installed.

In the following paragraphs, each of the three basic categories of equipment is analyzed by itself and in its relation to the overall system, but for sake of clarity in reverse order from above.

### Loudspeakers

There are two basic types of loudspeakers — horn speakers and cone speakers.

*Horn or trumpet type speakers* are capable of producing very high power sound output. Such units are particularly suited to outdoor applications (for example, playgrounds, athletic fields, outdoor industrial areas,) and indoor applications where high sound power is required to cover large areas (auditoriums, factories, gymnasiums, warehouses). Horn speakers require no auxiliary enclosures, and their rugged construction adds to their heavy duty, reliable nature.

Horn speakers are made of metal in a number of forms of flared horns and trumpets. In these speakers, sound waves are set up by a small moving diaphragm in a magnetic assembly called a driver.

An important characteristic of horn

*At first thought, planning for sound systems might seem to be an easy matter. The list of basic components certainly is not large, and their primary functions are clear enough. But the key to good performance lies in knowing not only something about equipment operation, but in how the electronic gear is designed, adapted and combined to meet particular requirements whether it be paging or hi-fi*

speakers is their inability to reproduce a very wide frequency range. In fact, their limited frequency response, directivity and high efficiency combine to make horn speakers ideal for locations where a generally high level of noise requires a sharp piercing reproduction of voice to override the noise.

Horn speakers are generally not used where music reproduction is important. There is, however, an all-metal, outdoor high fidelity horn, but this is an exception.

In the category of horn speakers, a number of variations are found. There are: so-called reflex trumpets (for directional sound projection), radial reflex projectors (for uniform dispersion in all directions), explosion-proof speakers (designed for use in hazardous locations), submersion-proof speakers (which are immune to salt spray, gasses, live steam, etc.) two-way and wide-angle dispersion speakers (for covering corridors and large areas respectively).

The second basic type of loudspeaker, the *cone type*, consists of a sound producing diaphragm of pressed paper in the form of a shallow cone, driven by a voice coil and magnetic assembly similar to the one used for the horn speaker. The cone speaker delivers its sound pressure output directly to the air, without benefit of a horn. (It is possible to use cone speakers with wood or metal horn structures to increase their efficiency, but this is not generally done.) The cone speaker is the type of speaker used in radios, television sets and home hi-fi units.

Cone speakers are less efficient than horn speakers but they generally are made with a wider frequency response. They can be made capable of clean, faithful reproduction of the complete range of sounds produced by musical instruments. Although they lack the long distance penetration of trumpets and large area coverage from a single unit, cone speakers are ideal for paging

**SOUND SYSTEM ASSEMBLIES**

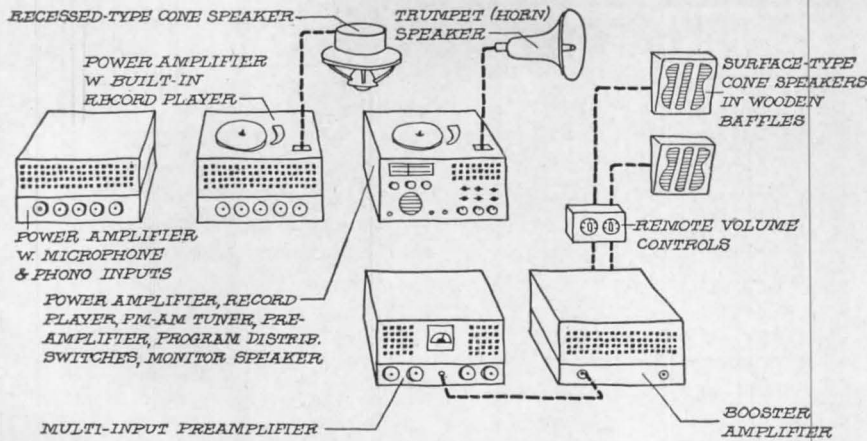

**Shelf-mounted units**

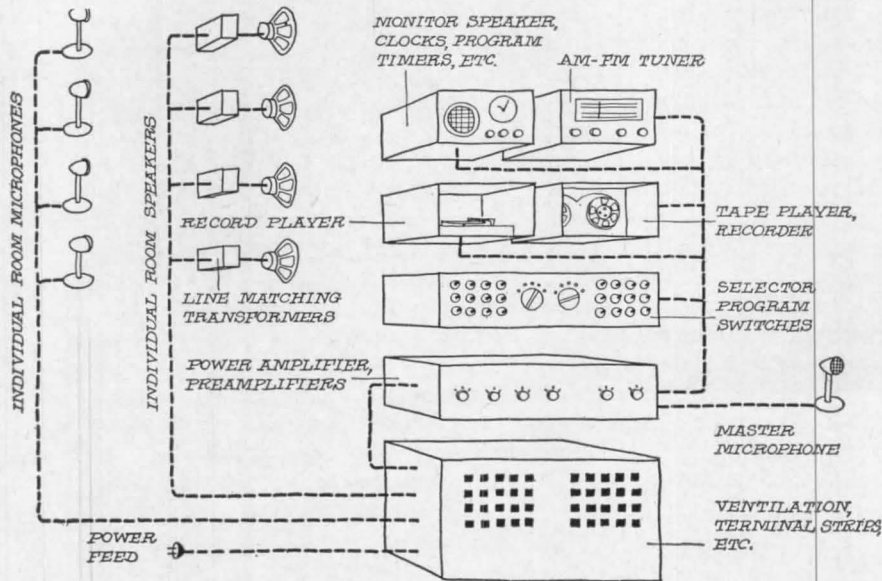

**Cabinet Rack Mounting**

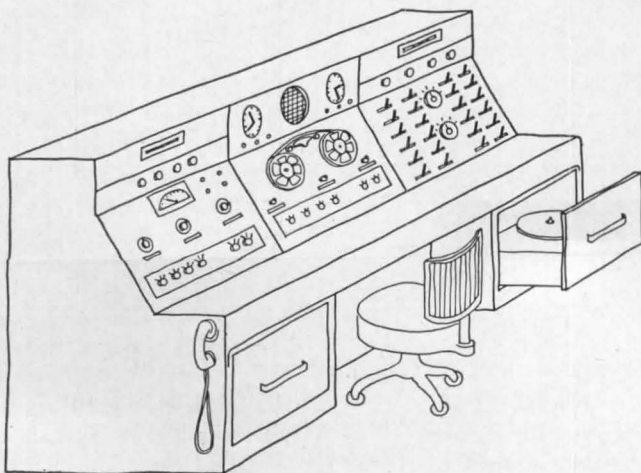

**Console**

and voice reproduction applications where general noise level is not high. Cone speakers are generally used indoors, but can be used for outdoor high fidelity reproduction if mounted in suitable weatherproof enclosures.

For best results a cone speaker must be used in a suitable enclosure or baffle — usually, a wooden box or metal enclosure of some type. Proper baffle mounting of the speaker assures maximum efficiency of speaker operation, minimizes distortion, smoothes frequency response and assures the best low frequency response of the speaker.

*Number of Speakers.* A fundamental problem in all sound installations is to determine the proper number of speakers to do the job. The decision frequently will have to be based on initial cost, convenience of installation and service, acoustic and esthetic factors. Among the latter are problems of reverberation, sound absorption and appearance. The problem reduces itself to the selection of one of two basic types of speaker systems: 1. high level, and 2. low level. In a high level system, sound is projected over a relatively large area from one or only a few speakers, each speaker operating at a very high level. In a low level system, a large number of speakers is evenly spaced throughout the area, each speaker operating at a relatively low level to cover only a small part of the total area.

*High level systems* find best application in large auditoriums, ball parks and theaters, where the speakers can be mounted at some distance from the audience to prevent blasting. In theaters and small auditoriums, a high level system which features a single sound source gives the illusion of sound coming from the lecturer because the volume can be adjusted to the lowest possible acceptable level.

*Low level speaker systems* are used for large spaces such as offices or in high noise areas such as factories where it is advantageous to place speakers close to the people hearing them. Railroad stations, airports and hotel lobbies are almost always wired with low level speaker systems. The low level of output from each speaker does not annoy or disturb anyone close to the speaker. In general, the speakers should be more or less equally spaced and mounted in strategic positions to provide uniform sound dispersion.

*Speaker Placement.* Obviously speakers should be mounted to provide uniform loudness over the area covered.

In churches, theaters and auditoriums,

speakers should be mounted well forward of the microphone(s) to prevent feedback, characterized by sustained high-pitched squeals when someone talks into the microphone.

Orientation of speakers is important in minimizing reverberation.

*Speaker Hookup.* Whether the sound system is of the simple type employing a single amplifier with a very limited number of speakers or one in which a group of amplifiers feeds varying amounts of power to a large number of loudspeakers, satisfactory operation depends upon an efficient transfer of power from the amplifier to the speakers. When the total loudspeaker load is properly connected to the output taps on an amplifier, their impedances are said to "match."\*

There are two methods for connecting one or any number of speakers to an amplifier to obtain impedance match. The first is direct wire connection of the loudspeakers to amplifier output taps having an impedance value equal to the impedance of the single speaker or equal to the resultant impedance of the series and/or parallel hookup of a number of speakers. The second method for connecting loudspeakers to an amplifier involves the use of small transformers (about the size of a pack of cigarettes), called "line-matching" or simply line transformers. The use of transformers permits mounting of speakers at great distances from the amplifier and provides the means for delivering varying amounts of power to individual speakers.

*Direct wire connection* of loudspeakers to an amplifier can be used when the speaker hookup is simple and the wire lengths to the speakers are less than 200 ft. When the speaker hookup is complex and the wire runs over 200 ft, and when it is necessary to keep power loss in the speaker line under 15 per cent, transformers must be used.

Depending upon the size and type of area each speaker must cover, the speakers will usually require that varying amounts of power be supplied to them. Speakers near a source of noise need more power than those in quiet areas; a single speaker covering a large area needs more power than a speaker covering a small area. By using series, parallel or series-parallel hookups, varying levels of power can be delivered to the speakers. The best method, however, for varying power levels at individual speakers is to use line transformers.

\* *Effective matching of the load to the amplifier exists when the resultant impedance of the speaker load (ohms) is approximately equal to the output impedance of the amplifier.*

*Matching with Transformers.* The use of a transformer at each speaker to match the speaker load impedance to the amplifier output impedance offers two important advantages:

1. It prevents excessive power losses in the speaker lines.

2. It simplifies distribution of varying power levels to individual speakers in installations requiring a large number of speakers.

There are two types of line matching transformers used to match speakers to amplifiers:

1. So-called "constant impedance" or "impedance matching" transformers. The primary is marked off in impedance values between 500 ohms and 14,000 ohms. Secondaries provide one or more voice coil values of impedance — usually 8 and/or 16 ohms.

2. "Constant voltage" transformers. This component is generally similar to the impedance matching transformer and differs essentially in that the secondary is marked in watts rather than ohms and provides for matching to 8 and/or 16 ohms loudspeakers. The primary taps are marked for connection to a 70-volt or 140-volt constant voltage line from the amplifier.

Most amplifier manufacturers in recent years have adopted constant voltage matching; it has proved very successful since a minimum of calculations is required to properly install a complex speaker system. This system is recommended in large multi-speaker installations. It permits changes in the number of speakers without recalculation of impedances and power delivered.

Also a more powerful amplifier may be substituted in an existing system at any later date without recalculation of the load and source impedances or changing connections on the line matching transformers.

### Amplifier Equipment

Amplifiers combining preamplifier and power amplifier in one chassis are the type most frequently used. They run as high as 50 watts output. The chassis provides a variety of volume control knobs, tone control knobs, as well as the necessary microphone and phono input connectors and loudspeaker output terminals.

In large sound systems running to 100 watts or more, separate preamplifier and power amplifiers are usually employed for greater flexibility. One or more preamplifiers may be used to drive one or more booster amplifiers; and it is not uncommon to find large complex

systems where a dozen or more amplifiers are connected to the output of a single preamplifier. In these large installations the preamplifier and booster amplifier chassis are mounted in consoles or vertical cabinet racks, with several program devices such as record player, tape recorder, radio tuner and tone generator, also mounted in the overall enclosure.

Many factors must be considered in selecting the proper amplifier, most important being

1. Power output required.
2. Number and types of inputs (e.g., microphone, phono).
3. Output impedance values.
4. Special functions.
5. Mounting of amplifier assembly.
6. Cost.

*Power Output.* To determine the amount of output power required from the amplifier, the number of loudspeakers in the system and the wattage level at which each loudspeaker will be operated must be known. If an installation requires ten loudspeakers — each providing approximately three watts — then an amplifier with an output rating of 30 watts is indicated. However a larger amplifier than required for minimum load is preferable. For instance, in the above example it would probably be a good idea to select a 50-watt amplifier in place of the 30-watt unit. The slight difference in amplifier cost is more than offset by the increased power available for future demands. So far we have been discussing maximum output power. It is still possible to regulate the loudspeaker output to any lower sound level by the means of the adjustable volume control on the amplifier.

For some idea of the total power required in typical installations, see the table in *Time-Saver Standards* p. 267. The values given represent averages and are not particularly critical.

Complete amplification units incorporating a preamplifier and the power amplifier on a single chassis are readily available with the following output ratings: 10, 15, 30, 50 watts. Separate booster amplifiers are usually rated at 30, 50, 70, 100, 125 or 250 watts. Where large amounts of output power are called for, any number of booster amplifiers may be incorporated in a single sound system and driven from the pre-amplifier.

*Number and Types of Inputs.* Standard "packaged" amplifiers are available for systems requiring from one to five microphones and a phono mechanism or radio tuner. In one manufacturer's

**TYPICAL HORN AND CONE SPEAKERS**

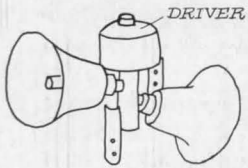

TWO HORNS BACK TO BACK POWERED BY SAME DRIVER UNIT COVER TWO OPPOSITE AREAS

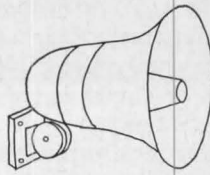

PAGING HORN ON ADJUSTABLE BRACKET

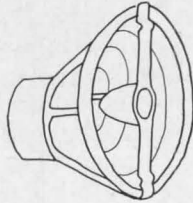

TRIAxIAL SPEAKERS HAVE 3 INDEPENDENT ELEMENTS, EACH REPRODUCING A DIFFERENT PORTION OF THE FREQUENCY RANGE.

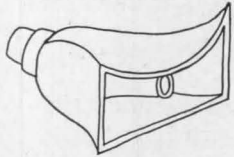

FLARED REFLEX SPEAKER FOR WIDE-ANGLE COVERAGE

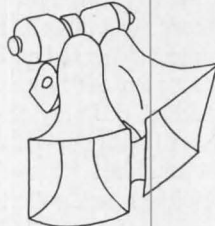

REFLEX TYPE; MAY BE USED WITH TWO DRIVERS FOR EXTRA POWER

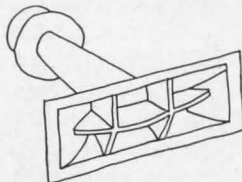

"TWEETERS" REPRODUCE HIGH FREQUENCIES

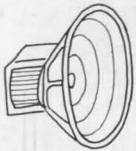

WIDE-RANGE CONE SPEAKER FOR USE IN WOOD OR METAL BAPPLES.



DRIVER UNITS ARE USED WITH HORNS. LINE MATCHING TRANSFORMERS ARE OFTEN BUILT IN.



HIGH-FIDELITY WEATHER-PROOF SPEAKERS FOR OUTDOOR STADIUMS, ETC.

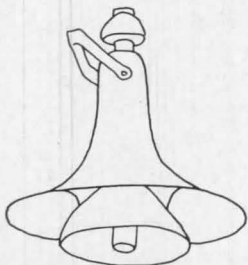

VERTICALLY MOUNTED RADIAL REFLEX PROJECTORS COVER FULL 360° AREA.

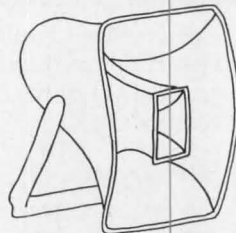

PROJECTOR FOR HEAVY-DUTY OUTDOOR APPLICATIONS

**Auxiliary speaker components**

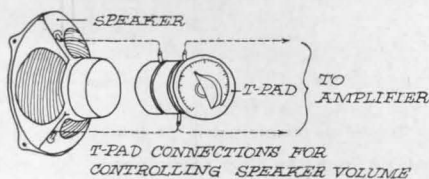

T-PAD CONNECTIONS FOR CONTROLLING SPEAKER VOLUME

LINE MATCHING TRANSFORMER PROVIDES CONSTANT IMPEDANCE TO INSURE PROPER MATCH BETWEEN SPEAKER & AMPLIFIER

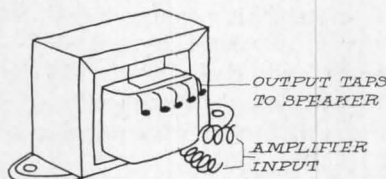

OUTPUT TAPS TO SPEAKER  
AMPLIFIER INPUT

line of equipment, it was found that a 10-watt amplifier provided one microphone and one phono input; a 15-watt amplifier provided two microphone inputs and one phono input; 30-watt amplifiers were available with one or three microphone inputs, plus one phono input. Rounding out the packaged line were two 50-watt amplifiers, the lower priced unit with two microphone inputs and one phono input — the deluxe version with four microphone inputs and one phono input.

When the length of microphone cable does not exceed 50 ft, a high impedance microphone may be used. On the other hand, if the microphone cable must be run to lengths exceeding 50 ft, it is necessary to employ a low impedance microphone with a low impedance microphone cable, and to convert the amplifier input to accept the low impedance signal. Conversion from high to low impedance input is a relatively simple matter with several amplifier lines and consists simply of removing a shorting plug from the top of the amplifier chassis and substituting for it a plug-in transformer. This technique permits the microphone channel to be reconverted from low to high impedance at any later date. It also affords considerable flexibility in that a four-microphone-channel amplifier may be set up to work, for instance, with two high impedance and two low impedance microphones.

*Special Functions.* There are several special characteristics and functions which may be desired in an amplifier: tone controls, remote control and stand-by operation.

*Controls* — An amplifier may be required to have control over tone as well as volume for the individual input channels, particularly for music reproduction. Separate bass and treble tone controls provide both boost and attenuation at the high and low frequency ends of the audio spectrum. (Examination of typical amplifier specifications will show that some units provide only reduction of high and low frequency sound, and do not boost.) Tone controls should be considered if the system is to be of very high quality or if reverberation and acoustic feedback problems are likely to be encountered. This problem can be very severe in indoor installations, but can be remedied in many cases by the use of an anti-feedback control incorporated in some amplifiers.

*Remote Volume Control* — In many sound system installations (i.e., church, theater, auditorium), it is desirable to

control the volume at some distance from the amplifier. Some amplifiers can be equipped with remote volume controllers for microphone and/or phono input channels which can be operated as far as 2000 ft from the amplifier.

**Standby Operation** — Frequently, sound systems used primarily for paging are operated only briefly and intermittently; yet the amplifier power must be available at all times for immediate use. To reduce power consumption considerably during standby periods and increase life of the tubes, some amplifiers are designed for a plug-in standby controller relay. This device is energized by a push-button in the base of the microphone stand which places the amplifier in full operation only for paging.

**Mounting of Amplifier Assembly.** Most packaged amplifiers have a protective cage so that the equipment may be safely installed on a shelf or table. If the amplifier is to be mounted in a standard cabinet rack, it may be purchased without the cage and with the chassis securely attached to a heavy gage front panel. The panel is marked to identify all controls and notched at both ends to fit the cabinet rack. A shock-mounting base is desirable in indoor installations where an amplifier is subjected to a vibration or shock.

Typical factors which affect the cost of amplifiers are as follows:

**Power** — Higher power amplifiers cost more because of larger transformers and huskier components.

**Frequency Response** — If an amplifier is to have a very wide frequency response for high fidelity it must contain well designed and sometimes elaborate circuitry, a very costly output transformer and frequently more expensive components.

**Distortion** — This may be considered as undesired difference between the input and output signals, and is expressed in a percentage value. Generally, the amplifier price increases as the distortion figure decreases. Typical good p.a. amplifiers designed for commercial installations are rated at approximately 5 per cent distortion (for full amplifier output). Some deluxe p.a. amplifiers are rated as low as 2 per cent. In a manufacturer's catalog, the distortion percentage is usually indicated for full amplifier power output. Distortion decreases as the output is reduced from full power.

### Program Sources

**Microphones.** Effective reproduction of speech and music by the sound sys-

tem depends to a considerable extent upon the microphone selected. There are many microphone types with a wide variety of characteristics to provide effective reproduction of speech and music. They may be classified according to their sensitivity pattern, the impedance of their outputs (high or low), principle of operation (crystal, dynamic or velocity).

**Sensitivity Pattern** — Microphones can be classified as uni-directional, bi-directional and omni-directional. These characteristics are extremely important, proper selection often making the difference in whether the system works properly or not. A uni-directional microphone, as might be expected, is sensitive to sound coming from one direction only and is selected frequently for stage and auditorium work. One of these is the cardioid microphone which enjoys tremendous popularity in night clubs and theater work because it rejects noise coming from the audience and provides pickup primarily from the performer or speaker. Its use is also dictated when acoustic feedback is a serious problem.

The bi-directional microphone will accept sound from both the front and back and is, therefore, a logical choice for interviews, dialogue work, etc.

The omni-directional microphone does not discriminate against sound from any direction and is widely employed for group pickup, roundtable discussions, etc.

**Output Impedance (High or Low)** — A high impedance microphone (which could be a crystal or dynamic type) must be operated within 50 ft of the amplifier since the higher frequencies are attenuated considerably as the distance increases. Also high impedance microphone lines will pick up hum and noise from nearby power devices, appliances and their associated power lines. If the distance between the microphone and the amplifier must be greater than 50 ft, a low impedance microphone, low impedance microphone cable and suitable amplifier should be employed. Low impedance microphones may be operated over lines well in excess of 500 ft without attenuation of high frequencies or serious loss of signal level; the danger of hum and noise pickup from adjacent appliances and power lines is considerably reduced.

**Microphone Types** — When classified according to the fundamental principle of operation, we find three basic types of microphones: carbon, crystal and dynamic. The carbon microphone is al-

(Continued on page 270)

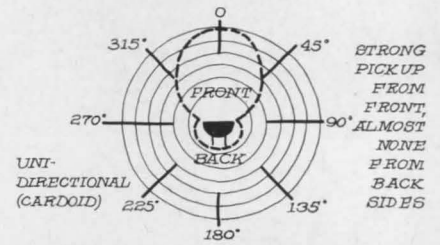
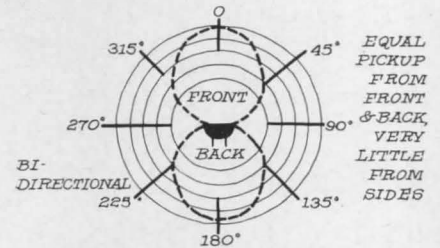
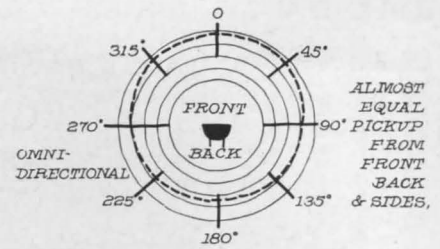

Types of microphones classified by directional patterns

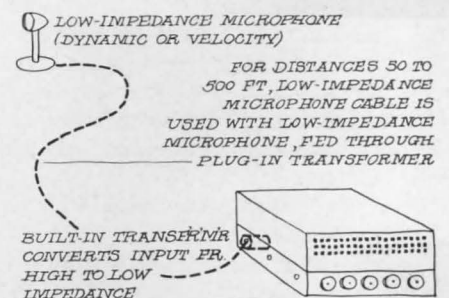
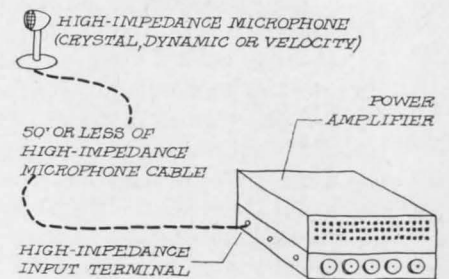

Selection of microphone and cable based on distance from amplifier

## PRODUCT REPORTS

Materials • Equipment • Furnishings • Services



### STRESSED-SKIN PLYWOOD PANELS SIMPLIFY FRAMING, CUT BUILDING COSTS

A STRUCTURAL SYSTEM combining the flexibility of custom design with the time- and labor-savings of prefabrication offers new possibilities for low-cost construction.

Industrial designer Peter Bilder's *Panelbild* system employs sturdy stressed-skin panels, built with thin sheets of fir plywood glued to appropriate framing members, for floors, walls, and roofs. Custom-assembled according to the specifications of individual designers, the large structural units can be installed easily and rapidly without conventional framing. The panels, which are normally either two or four feet wide, will carry up to five times the maximum design load over spans from 8 to 20 ft. Although the thickness of the stressed-skin varies according to job requirements,  $\frac{3}{8}$  in. plywood is generally used for the top layer, and  $\frac{1}{4}$  in. for the bottom.

The panels are assembled with the top and bottom plywood surfaces slightly off center along their length to form an exaggerated tongue and groove. The side framing of one panel fits inside the overhanging plywood edges of the adjacent panel so that the plywood

surfaces butt solidly together. Extra space left in the groove of the longitudinal joint provides a wiring chase and permits slight variations in placement of the supporting members. Insulation, usually glass fiber between the panels and an aluminum reflective surface on the underside of the top skin, is applied in the shop.

Architects, Lea, Pearson and Richards AIA, of Tacoma, Washington recently made extensive use of the panels in a clinic designed as the headquarters for two Tacoma physicians. A U-shaped, one-story structure built around a small covered court, the clinic has floors, walls and roof of stressed-skin plywood. A simple post and beam framing system with 4 in. by 6 in. beams spanning 4 in. square posts, four feet on center, provides supporting members for the roof and wall panels. Even the foundation is laid out so that concrete footings on 14 ft. centers support the floor panels — in most cases without further framing, although a few girders and piers are used where dictated by the floor plan. *Panelbild Systems*, 7010 196th S. W., Lynnwood, Washington

(More Products on page 284)

*Versatile stressed-skin plywood panels replace conventional framing for floor, walls and roof of this one-story clinic. Built to individual designers' specifications, panels span up to 20 ft, bear as much as five times design load.*





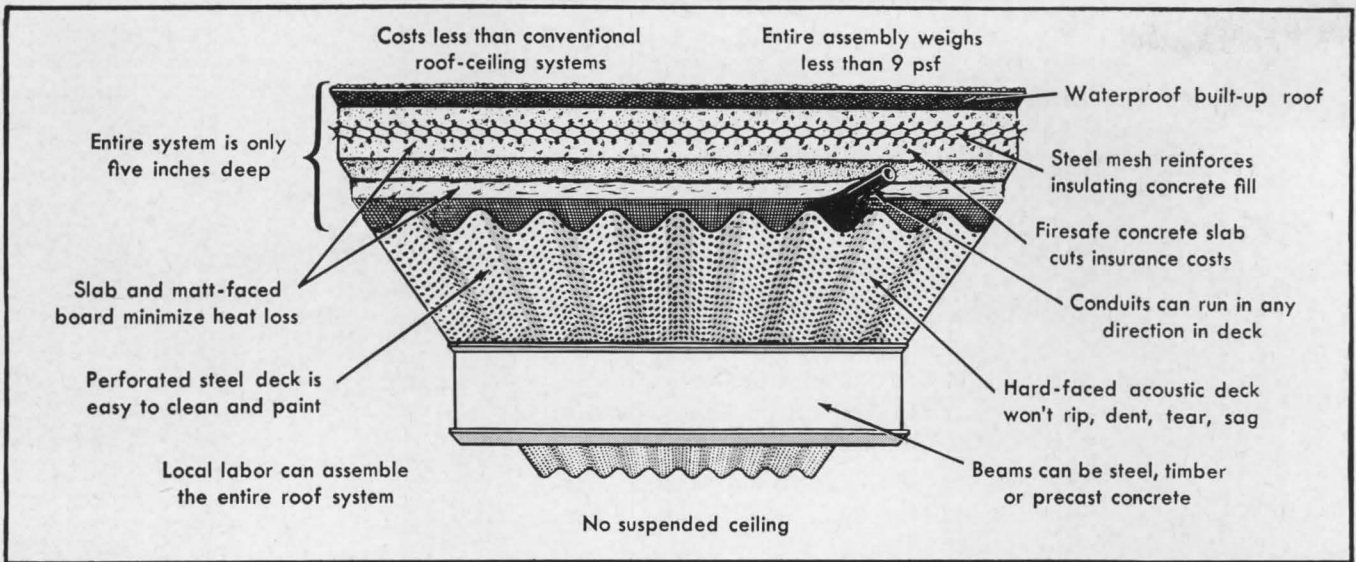

## New idea in school ceiling-roof construction

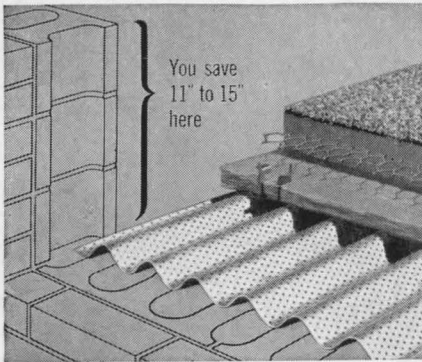

**5-INCH SYSTEM.** A suspended ceiling system usually requires 16" to 20" in depth. Only 5" deep, the Structur-Acoustic system saves 11" to 15" in wall height, saves thousands of dollars in materials and labor.



**GOOD ACOUSTICS.** Tests conducted by Riverbank Acoustical Laboratories indicate that Structur-Acoustic system with 2½" slab provides Noise Reduction Coefficient of .80. Clean, corrugated underside of Structur-Acoustic reflects light, can be painted to matching color scheme. Hard surface won't dent, stays attractive. Heat loss is kept to minimum with U factor in excess of 0.14. Firesafe system protects both building and contents, helps reduce owner insurance costs.

## NEW STRUCTUR-ACOUSTIC DECK MAKES 5-INCH ROOF SYSTEM POSSIBLE

EASY TO ASSEMBLE, USES LOCAL LABOR

A new combination of building materials, the Structur-Acoustic roof system eliminates suspended ceilings, offers one-third more roof for your dollar than conventional school roofs with similar features. Heart of the system is Structur-Acoustic—a galvanized, corrugated, perforated steel sheet that weighs only 2 psf. Strong but lightweight, these high-tensile, tough-temper steel units are easy to handle and place, form a firm structural deck for the ceiling-roof assembly. Entire system can be assembled by local labor—no bulky prefabricated assemblies to ship long distances at high freight rates. For schools, one-story offices, factories, stores—wherever sound control is desirable. For more information, contact Granco home or district office, ATTN: Dept. R-74.



See our catalogs in Sweet's Architectural and Industrial Files

**GRANCO® STEEL PRODUCTS COMPANY**  
A subsidiary of GRANITE CITY STEEL COMPANY  
6506 N. Broadway, St. Louis 15, Mo. Executive Offices: Granite City, Ill.  
DISTRICT OFFICES: St. Louis • Kansas City • Cincinnati • Dallas • Chicago  
Minneapolis • Atlanta • San Francisco  
Distributors in 80 principal cities

Granco Products for any type of framing you specify



CORRUFORM® COFAR® GRANCO ROOF DECK TUF COR® STRUCTUR-ACOUSTIC

# **FILON**® Fiberglas Panels bring out the best in your design

Fresh interplay of color and light patterns... eye-privacy between areas without darkening either area... soft, diffused light... colors as dramatic or subtle as your problem calls for... California-living features the whole nation's hungry for... the easy, airy flow of indoor-outdoor living.

Now you can design these with complete confidence for industrial, community and residential use. FILON gives you translucent polyester panels, reinforced with both fiberglas and nylon, quality-controlled by patented, continuous electronic process for high uniformity of thickness, strength and color. You'll find all technical data in Sweet's File.

FILON is easy to specify, easy to install, easy to get. Your building materials people stock it or can get it immediately from any of 100 distributors' warehouses coast to coast and in Canada.

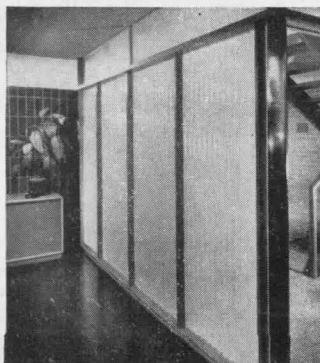
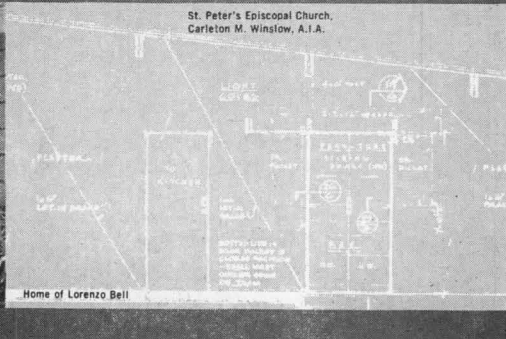
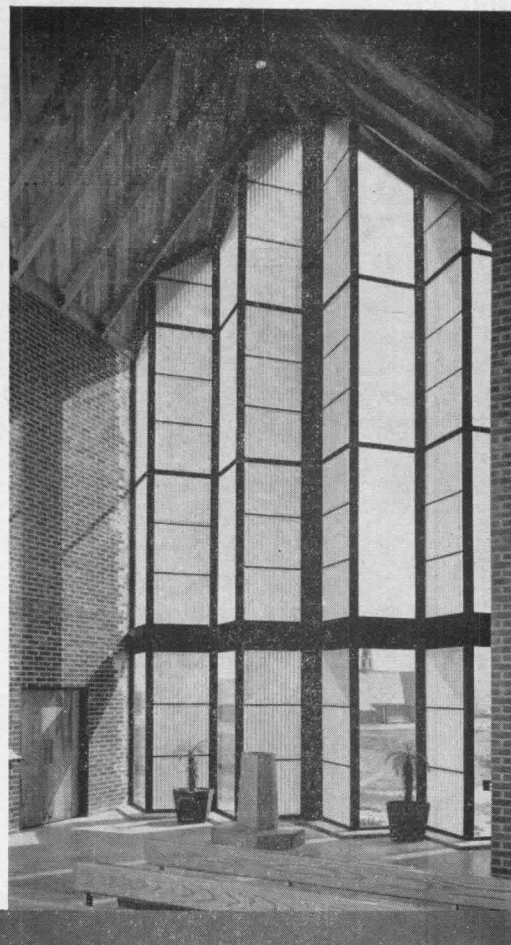

Gemological Institute of America  
Richard J. Neutra, F.A.I.A.

White, and in 19 decorator colors, FILON comes flat, shiplap and in several corrugations, many sizes. FILON is shatterproof, weatherproof, heat repellent, beautiful.

Your own imagination will add to this list of uses for FILON: skylights • sidelights • windows • patio and porch roofs • room dividers • partitions • sliding wall panels • carports • fences • awnings • overhangs • breezeways • windbreaks • canopies • Shoji treatments.

And remember quality makes a big difference in fiberglas panels. For your protection, insist on the FILON label on every panel.

See HOUSE BEAUTIFUL, LIVING FOR YOUNG HOMEMAKERS, FORTUNE, BETTER HOMES & GARDENS and SUNSET where four-color ads tell your clients to discuss FILON with you.

*Wonderchild of Building Materials • Fiberglas and Nylon Reinforced Panels*

**FILON PLASTICS CORP.** 2051 E. Maple, El Segundo 21, California  
LOS ANGELES    NEW YORK    CHICAGO    ATLANTA    PALO ALTO    ZURICH

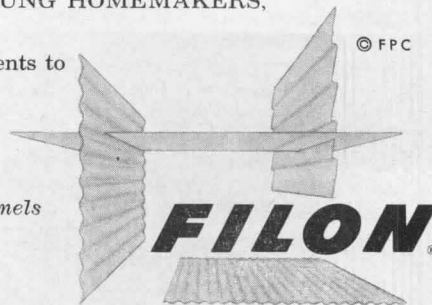

## SOUND SYSTEMS—1: Sample Specifications and Definitions

By J. F. McPARTLAND, Engineering Editor, *Electrical Construction and Maintenance*

A. "A jack panel 2 in. wide, 19 in. long with 24 pairs of jack inputs shall be mounted on front of amplifier cabinet. Nine pairs of jacks shall terminate microphone lines through seven pairs of jacks on second row which shall connect seven preamplifiers. Four additional pairs of jacks shall terminate telephone wire and input lines from rooms as indicated in drawings."

B. "The amplifier cabinet shall house a selenium rectifier designed to supply 110 volts dc for field excitation of three auditorium electrodynamic speakers."

C. "Power amplifier shall furnish all voltage for its own requirements and for the preamplifiers. Output shall be 50 watts with less than 5% harmonic distortion, or 40 watts with less than 2% harmonic distortion. Tube complement shall provide push-pull driver stage and push-pull parallel output stage. Overall gain of voltage and power amplifier is to be 105 db at 1000 cycles. Frequency response shall be flat from 50 to 10,000 cycles within plus or minus 2 db. Output transformer shall have tapped secondary providing a 4 to 250 ohm impedance range."

D. "A high-quality balance line transformer coupling output of power amplifier to telephone wire line input shall be furnished. Frequency response shall be 30 to 15,000 cycles within plus or minus 1 db."

E. "Voltage amplification shall be accomplished by seven preamplifiers and the master mixer. Each preamplifier shall have a separately controlled 250-ohm input impedance and shall use a 1612-type tube, the filament and plate voltages of which are supplied by the associated power amplifier."

"The master mixer unit shall be furnished having a high-impedance input and master gain control. Control of gain to be accom-

### SOUND SYSTEM LAYOUT FOR LARGE SCHOOL

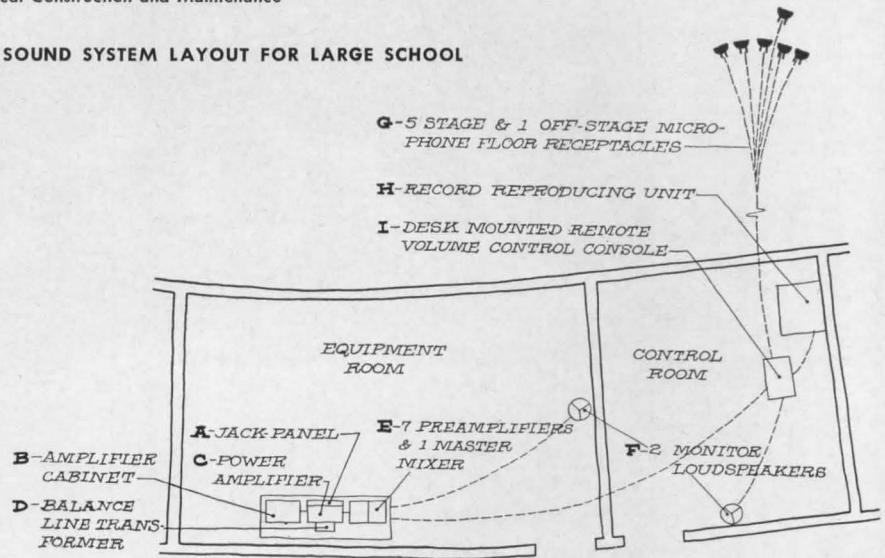

plished in same manner as preamplifiers."

F. "There shall be provided two monitor loudspeakers, one each in equipment room and control room; surface type; 3-watt; 7 in. diameter; 4-in deep cones; voice coils 6 ohms; impedance actuated by Alnico permanent magnets equipped with multi-tap speaker-matching transformers. The cones shall have a frequency range from 70 to 8000 cycles with a distribution angle of 165 degrees at 1000 cycles. Speakers shall be mounted behind metallic grille cloth in a sloping front surface-type wall housing, sloped to blend with wall at bottom."

G. "Five stage and one off-stage microphone floor receptacles are to be equipped with one each varacoustic microphone having a frequency response of 80 to 8000 cycles; adjustable characteristics so as to permit

its use in non-directional, bi-directional, or uni-directional pickup. Impedance 250 ohms, output 58 db."

H. "Reproduction of recorded programs shall be by means of high-quality record reproducing unit having a cushion-mounted motorboard and a felt-covered balanced 16-in. turntable disc, driven by a high-torque motor, through rollers which will permit operation at either 78 or 33 $\frac{1}{3}$  RPM. Frequency response of turntable shall be 70 to 8500 cycles."

I. "A desk-mounted remote volume control console, to be located in control room, shall be provided for monitoring of reproduction from a remote point. Controls are to be connected in parallel to the controls on voltage amplifiers. A volume control shall be provided for the monitor speaker."

### SOME TERMS USED IN SOUND WORK

**Acoustic Feedback** — The transfer of sound from the loudspeaker back into the microphone in such a manner as to create an annoying squeal or howl.

**Amplifier** — A device of electronic components used to strengthen the originating signal from a microphone or record player to the point where it will operate loudspeakers

**Baffle** — Most commonly used synonymously with loudspeaker housing and may be a suspended, or surface or recessed, ceiling or wall mounting device made of wood, plastic or metal, in which a loudspeaker is housed.

**Booster Amplifier** — An amplifier designed to boost the level of a signal from a pre-amplifier to provide power for driving loudspeakers.

**Decibel** — A unit used to measure the relative loudness of sound. Engineers employ the term also to designate power or voltage ratios.

**Gain** — Usually expressed in decibels, this

term is applied to indicate the increase in voltage or power output over the voltage or power input.

**Impedance** — Literally the opposition that a circuit offers to the flow of alternating current. Primarily used in the sound field as an important characteristic of amplifiers, microphones and accessories.

**Loss** — A term usually expressed in decibels to indicate the decrease of voltage or power output from voltage or power input.

**Mixer** — Usually a pre-amplifier which permits several microphones, record player and/or radio tuner to be combined through volume controls. The suitably mixed signal is then usually fed to the input of a booster amplifier.

**Monitor Loudspeaker** — A small loudspeaker mounted in a console or cabinet rack (or adjacent to these) which provides an audible indication of the sound level of the system and which permits preliminary adjust-

ment of the amplifier output before distribution to remote loudspeakers.

**Pre-Amplifier** — Frequently used synonymously with mixer, although it may be designed to provide for increasing the level of only one input signal.

**Radio-Tuner** — Permits reception of AM or FM programs. Differs from receiver in that it does not incorporate audio amplifier and loudspeaker.

**Reproducer** — The cartridge mounted in the tone arm which tracks the record grooves by means of a stylus (needle), picking up the electrical signal equivalent of the music or sound which was recorded.

**Turntable Pickup** — Includes the tone arm, cartridge and stylus (needle) which follows the record grooves and provides an electrical signal suitable for feeding into a pre-amplifier, mixer or amplifier.

**Volume Level Indicator** — A device (meter, neon bulb, etc.) which permits the operator of a sound system to determine visually the sound level output.

# HEARD EVERYWHERE Lowell<sup>®</sup>

THE SOUND CHOICE / AL SERIES BAFFLE

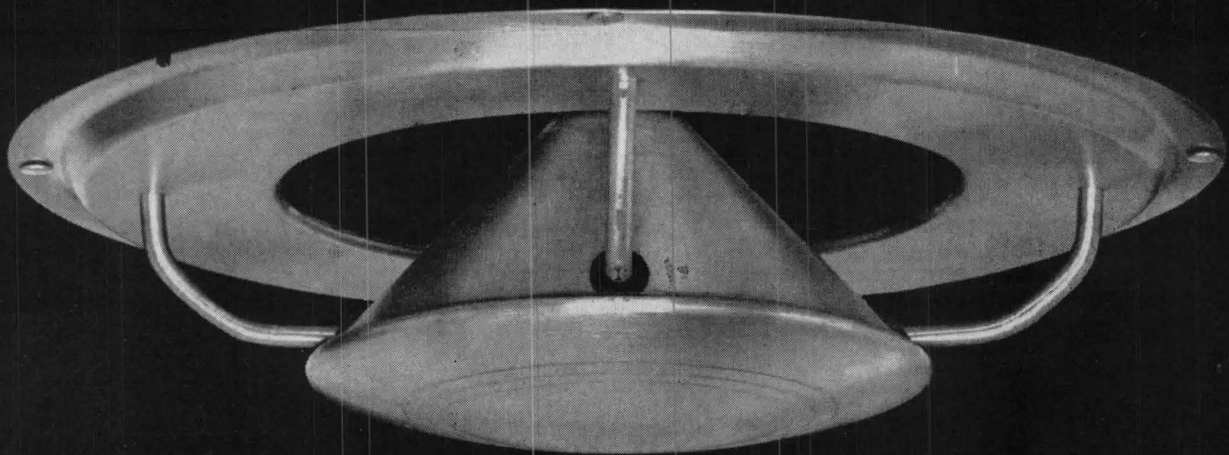

## *Beautiful . . . in appearance and in performance.*

Mounts flush for low-ceiling areas. Effective 360° dispersion of clear "ear level" sound. Conical diffuser "floats" on soft rubber grommets. Heavy gauge aluminum. Sizes available for 6" to 15" speakers. Easily installed.

**LOWELL:** One source for immediate delivery. More than 100 models of ceiling and wall baffles, enclosures, grilles, accessories, intercom equipment.

*Write for complete information and specifications.*

World-wide representation

HEARD EVERYWHERE  
**Lowell** MANUFACTURING CO.

3030 LACLEDE STATION ROAD • ST. LOUIS 17, MISSOURI  
IN CANADA: ATLAS RADIO CORP., LTD., 50 WINGOLD AVENUE, TORONTO 10, ONTARIO



## SOUND SYSTEMS—2: Design Considerations

By J. F. McPARTLAND, Engineering Editor, *Electrical Construction and Maintenance*

### 1. LOUDSPEAKERS

#### A. Number of speakers (depends upon size, shape and type of area)

1. One or a few, each operating at high output (high-level speaker system)
2. Relatively large number, each operating at low output (low level speaker system)

#### B. Types of speakers

1. Cone speakers in wall-mounted, ceiling-mounted, or suspended-baffle enclosure
2. Horn speaker (trumpet, projector horn, re-entrant horn, etc.)

#### C. Amplifier connection

1. Direct connection to amplifier output taps corresponding in impedance value (ohms) to impedance value (ohms) of a single speaker or of a number of speakers in series, parallel, or series-parallel
2. Connection to amplifier constant-voltage output taps (70, 100, 140 volts, etc.) through constant-voltage line-matching transformers
3. Connection to amplifier high-impedance output taps (250 or 500 ohms) through constant-impedance line-matching transformers.

#### D. Placement of speakers

1. Assure uniform loudness (eliminate dead or hot spots)
2. In churches, theatres and auditoriums, place speakers well forward of microphones to prevent feedback (squealing)
3. Minimize reverberation

### 2. AMPLIFIERS

#### A. Power output

1. Typical ratings: 6, 10, 15, 30, 50, 70, 100, 125, 250 watts
2. Output required depends upon size and type of area to be covered in sound system (see accompanying table)

#### B. Number and types of inputs (terminals for connecting high- and/or low-impedance microphones, record player or radio tuner)

#### C. Output taps (impedance values)

1. Direct connection: 4-, 8- and 16-ohm taps
2. Constant-voltage line transformer connection: 70-, 100-, or 140-volt taps
3. Constant-impedance line transformer connection: 250- and/or 500-ohm taps

#### D. Special functions

1. Record player built into amplifier housing
2. Amplifier, microphone and speakers in carrying case (portable system)

#### E. Controls

1. Tone
2. Anti-feedback

#### F. Remote volume controller (plug-in unit for use at distance from amplifier)

#### G. Power source

1. 110-125 v ac, 60 cycles
2. 115 v ac, 25 cycles
3. 115 v dc
4. 6 or 12 v dc

#### H. Amplifier mounting

1. Portable, with protective cage
2. Panel-mounted, for installation on rack

#### I. Cost (increases with power rating and fidelity of reproduction)

#### J. Separate preamp unit (for one or more remotely located power or booster amplifier)

#### K. Custom assemblies (amplifier, preamp, ratio tuner, record player, or other input devices mounted in vertical cabinet rack or console cabinet)

### 3. INPUT DEVICES

#### A. Microphones

1. Crystal, dynamic or velocity
2. Omni-directional, bi-directional, or uni-directional (cardioid)

#### B. Record player (automatic or manual)

#### C. Tape player

#### D. FM-AM radio tuner

#### E. Tone generator

1. To produce tone signal for factory work shifts, lunch periods, etc.
2. Electronic siren for alarm applications
3. To simulate sound of large bell in church belfry

AMPLIFIERS AND SPEAKERS FOR VARIOUS APPLICATIONS

Application	Sq. Ft. Area	Amplifier Rating (Watts)	Number of Speakers	Type of Speakers
Auditoriums	2,000	15	2	12" Cone in Wall Baffles
	5,000	30	2	12" Cone in Wall Baffles or
	15,000	50	4	12" Projector Horns
Ballrooms	2,000	15	4	12" Cone in Wall Baffles
	4,000	30	4	
	10,000	50	6	
Churches	1,000	10	2	10" Cone in Wall Baffles
	4,000	15	2	12" Cone in Wall Baffles
	15,000	30	4	
Classrooms, Offices and Stores	500	10	1	8" Cone in Wall Baffles
	2,000	15	2	10" Cone in Wall Baffles
	8,000	30	4	
Factories	1,000	15	2	12" Projector Horns
	4,000	30	4	
	8,000	50	4	Re-Entrant Horns
	40,000	100	10	
Funeral Parlors	1,000	10	1	12" Cone in Wall Baffles
	4,000	15	4	
	10,000	30	8	
Restaurants and Night Clubs	1,000	15	2	12" Projector Horns
	5,000	30	6	
Stadiums and Gymnasiums	10,000	50	12	
	3,000	15	2	12" Cone in Wall Baffles
	10,000	30	4	Re-Entrant Horns
	50,000	100	8	

NOTE: Values given in table are averages — not minimums or maximums.

**ShoDoCo**

World's Most Respected Name in the Manufacture of Glass Shower Enclosures

*presents the newest . . .*



## **Vue-Lume<sup>®</sup>** **ROLLING GLASS DOORS**

The World's first rolling glass doors with \*All-Points Weatherseal, and \*Unconditional 12 Year Guarantee

- \* Vue-Lume's exclusive AP (All-Points) Weatherseal of deep pile mohair at threshold, header, interlocker and jamb seals as snugly as a refrigerator.
- \* The sturdiest engineering design, the most exacting mechanical tolerances, and the finest quality materials obtainable allow ShoDoCo to unconditionally guarantee VUE-LUME Rolling Glass Doors for 12 years—another industry "first".

Exclusive PermaSatin finish, developed by ShoDoCo, gives Vue-Lume Doors beauty and hardness never seen in aluminum.

Made in 6'10" and 8' heights, there are 24 standard sizes in 2, 3 and 4-panel models with widths up to 24'—plus custom sizes to fit any opening—America's most complete range and line of standard models.

For name of your nearest distributor and further information, fill out this coupon and mail to:

Shower Door Company of America  
Dept. AR-357  
1 Permalume Place, N.W., Atlanta, Ga.

Name \_\_\_\_\_

Address \_\_\_\_\_

City and State \_\_\_\_\_

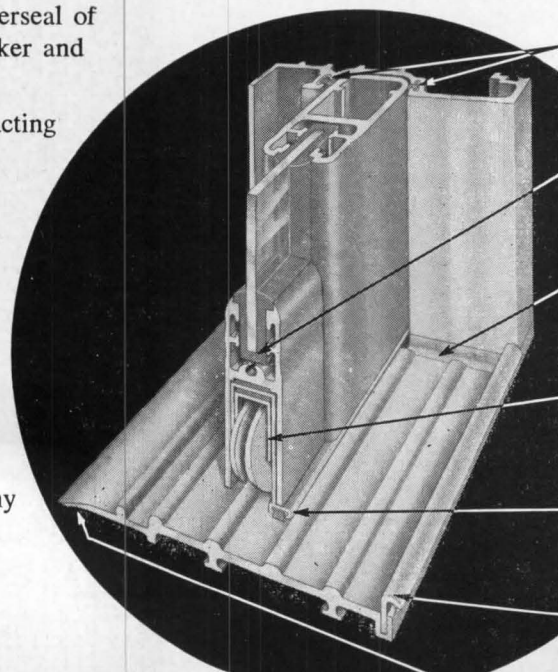

DOUBLE WEATHERSEAL

DEEP GLASS PENETRATION

CAST CORNER SECTIONS

ADJUSTABLE ROLLERS

ADJUSTABLE WEATHERSEAL

SPECIAL CONDENSATION DAM

NO-TRIP THRESHOLD

*Shower Door Company*  
**OF AMERICA**

1 PERMALUME PLACE N.W. ATLANTA 18, GA.

**WORLD'S LARGEST MANUFACTURER OF SHOWER ENCLOSURES**

**SOUND SYSTEMS — 3: Wiring Symbols**

By J. F. McPARTLAND, Engineering Editor, *Electrical Construction and Maintenance*

**ANTENNAE**

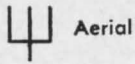
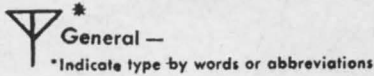

**GENERAL —**

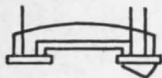
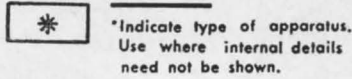

**HAND SET**

3-conductor

**JACK**

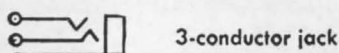
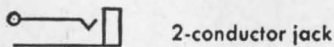

**LAMP**

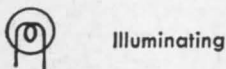
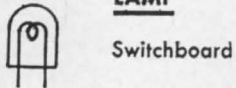

**LOUDSPEAKER**

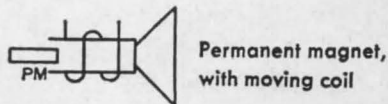
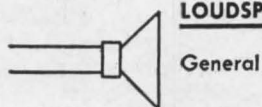

**MICROPHONE**

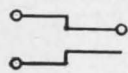
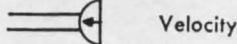
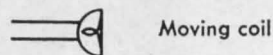
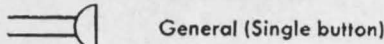

**PLUG**

2-conductor switchboard plug

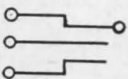

3-conductor switchboard plug

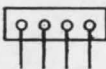

Gang

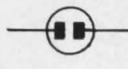

Non-polarized (Number of terminals as required)



Polarized



3-conductor polarized

Radial prong indicates polarization

**RECEIVER**

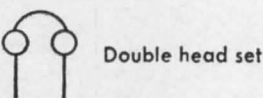
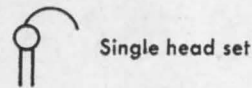
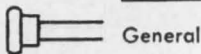

**RECEPTACLE**

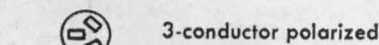
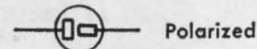
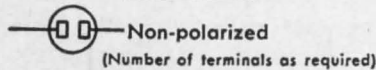

Radial contact indicates polarization

**RELAY**

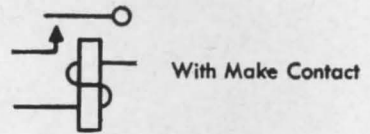
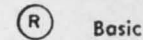

**REPRODUCER (PICK-UP)**

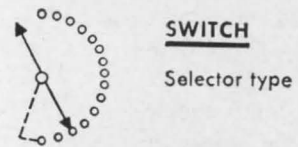
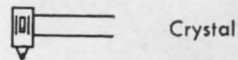
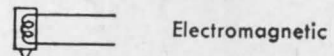
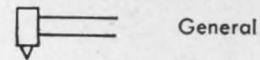

**TRANSFORMERS**

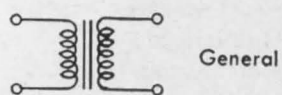

**VOLTAGE SOURCE**

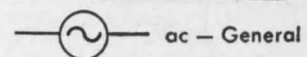

**WIRING**

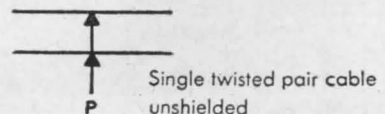
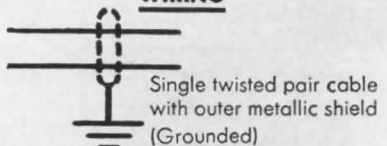

Wherever people give a building  
a beating

outside



or

inside

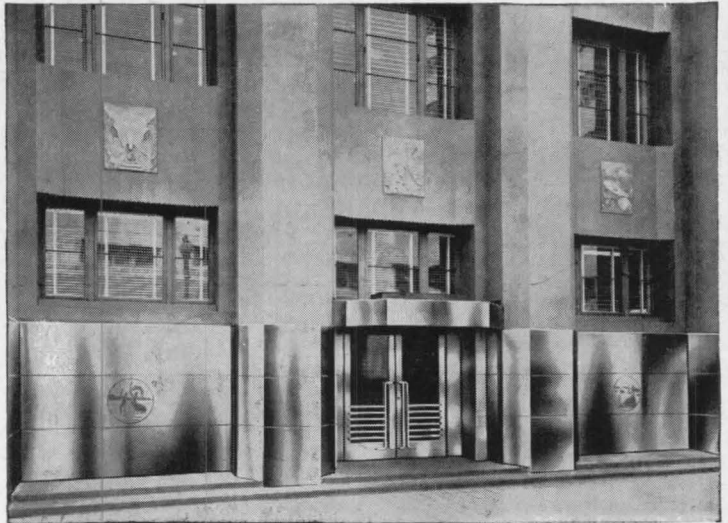

## That's the place to use **STAINLESS STEEL**

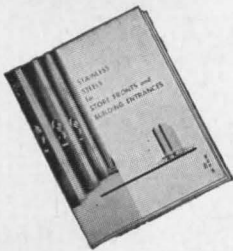

Write for your copy  
"STAINLESS STEEL for  
STORE FRONTS and  
BUILDING ENTRANCES"

If modernization or new construction is on your mind, this 40-page booklet contains many ideas on handsome treatments for you. (Note: A new booklet on "AL Stainless in Food Preparation and Serving Equipment" is in process—write for one of the first copies when available.)

Address Dept. R-87

You *have* to design for maximum attractiveness in those areas of buildings which have most traffic—such as building fronts, marquees, entrances, lobby details, railings, etc. Yet those same places are exactly the locations where you need maximum utility, too.

What's the *best* material to use? Just remember that stainless steel—and *only* stainless steel—gives you the nearest-to-perfect combination of satiny beauty and rugged toughness. No other material is as good-looking and at the same time as

strong, hard-surfaced and resistant to rust or discoloration. No other material requires as little maintenance, cleans as easily and lasts as long.

In short, whether you're considering AL Stainless Steel for just the "hard-wear" spots or for an entire curtain-wall design, keep this fact in mind: *no other material costs as little over the long pull as stainless steel.*

Let us give you any information or technical assistance you may require.  
*Allegheny Ludlum Steel Corporation,  
Oliver Building, Pittsburgh 22, Pa.*

For Stainless Steel in ALL Forms—call  
**Allegheny Ludlum**



WSW 5209 C Warehouse stocks carried by all Ryerson Steel plants



running into low ceilings?  
get new GUTH SLIMLUX...only 4¼ inches deep!



WRITE TODAY FOR ALL DETAILS

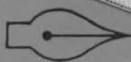

Low modern ceilings call for slender surface-mounted fixtures, and Guth answers the call with ceiling-hugging SLIMLUX.

SLIMLUX operates cooler, too. It's built extra-rugged—with high-quality ballasts—to maintain 90° (or lower) operating temperature and give top ballast performance. Be sure that the surface fixture you specify is heat-tested!

**SLIMLUX OFFERS A HUGE VARIETY OF MODELS**

... for every application. Here are some of your choices:

- 2-light or 4-light widths
- 4-foot or 8-foot lengths
- Sides: L. W. with Light Windows, or S. S. with Solid Sides
- GrateLite louver diffuser\*, metal cross baffles, or Pattern #70 low brightness lens.

\*© U. S. Pat. No. 2,745,001  
Can. Pat. Pend.

THE EDWIN F. GUTH COMPANY



TRUSTED

NAME IN LIGHTING SINCE 1902

## SOUND SYSTEMS

(Continued from page 259)

most never used in commercial sound systems.

The crystal microphone is always a high impedance type, very economical and capable of excellent performance. Its application must be confined to places where temperatures are below 125 deg F.

The dynamic microphone is constructed somewhat like a miniature dynamic loudspeaker and actually operates on the same principle. Because of such factors as its ruggedness, wide frequency response, moderate price and availability with either high or low impedance output, it is probably the most popular type in use today for commercial sound systems. Some high impedance dynamic microphones are assembled with a small switch at the rear of the instrument which permits the selection of high or low impedance.

**Other Types** — Infrequently the requirement for the highest possible quality will indicate the use of a velocity or ribbon microphone which is used often in broadcast studio work. This type of microphone is more fragile than the dynamic.

**Tone Generators.** It has become almost standard practice to include a tone signal generator in the larger console and vertical cabinet rack assemblies installed in factories. A typical tone oscillator of this type may be easily connected to the time clock in the factory to give a steady tone of short duration. In more elaborate systems, it is not unusual to find an electronic siren which can be triggered not only at the amplifier assembly but also from remote points in the building to indicate the presence of fire. For church sound systems, a small built-in device simulates the tone of a bell.

### Cables

The cables which connect the microphone(s) or other input devices to the amplifier or which connect preamplifiers to booster amplifiers are called "input leads." An input lead may be any one of several types of cable assemblies either run free or carried in conduit. The more common types of input leads are:

**Microphone Cables.** In general, there are two types of specially designed cables used to connect microphones to amplifiers: (a) high impedance cable, (b) low impedance cable. They are used with microphones with these designations.

**Phono Leads.** The cable used to con-

nect record players (manual or automatic) to amplifiers is invariably a single shielded conductor.

**Output Leads.** Cables run from the output taps on the amplifier to the loudspeakers (either directly or through line matching transformers) are called "output leads." Such wiring is not usually susceptible to interference from power or signal circuits and does not ordinarily require the shielded conductors used with microphones. In some special sound installations — as in a school system

where the classroom loudspeaker is often employed for intercom purposes — the loudspeaker line may have to be shielded. In multi-channel sound systems installed in hotels and hospitals it is also standard practice to use shielded twisted pair speaker lines to prevent cross talk (transfer of a signal from one line into an adjacent line). In the majority of speaker hookups, however, an unshielded single twisted pair cable with an outer cover of cotton braid or vinyl plastic is generally used.

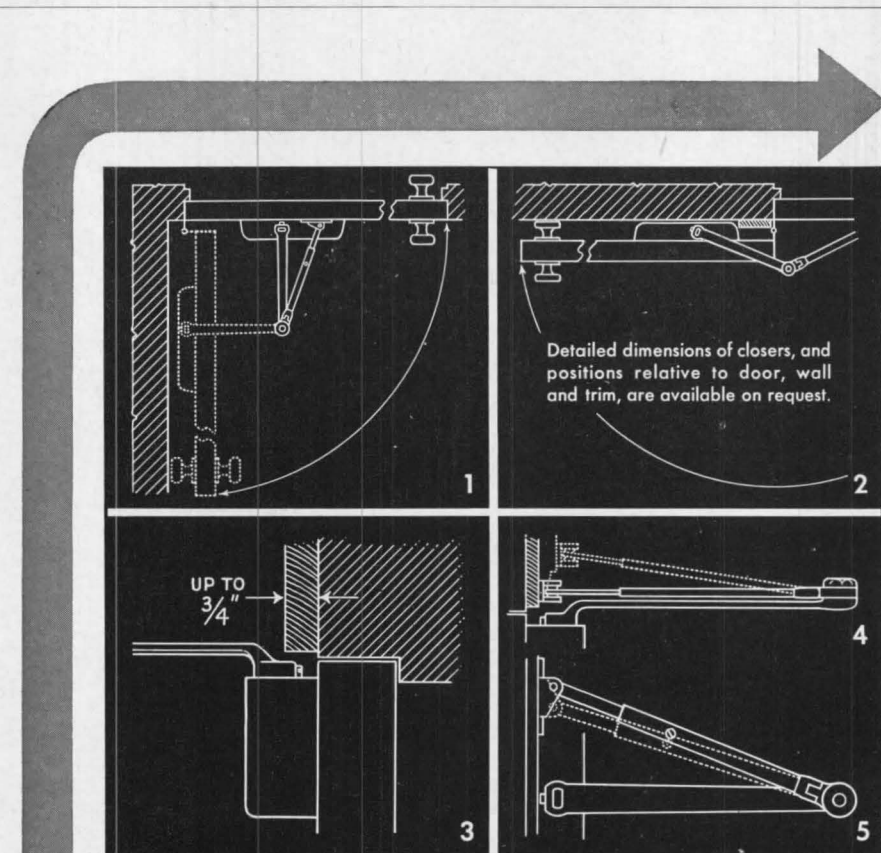

## APPLICATION DETAILS

for the New LCN "Smoother" Exposed Door Closer  
Shown on Opposite Page

As Demonstrated in Drawings Above:

1. The LCN "Smoother" takes less space than most doorknobs between door and wall.
2. Degree of door opening possible depends mostly on type of trim and size of butt used.
3. Arm of LCN "Smoother" is curved to avoid conflict with almost any conventional trim.
4. Joints in arm and shoe make it easy to vary the height of shoe as needed for beveled trim.
5. Power of closer is increased or decreased by simply reversing position of shoe.

May we send a descriptive folder? Or a complete LCN Catalog, if you like? Address

**LCN CLOSERS, INC., PRINCETON, ILLINOIS**

# NEE

## The Preferred Plumbing

# hospital people helped design!

How would you go about designing specialized hospital plumbing fixtures? Well, Crane went right to the source—to doctors, medical technicians, hospital management people and hospital architects.

Part of the result you see here—hospital fixtures designed specifically for hospitals and for hospitals only—not just adaptations of residential fixtures.

The larger fixtures are made of the exclusive Crane Duraclay—a vitreous

glazed earthenware that has been adopted by thousands of hospitals during the past 15 years. Duraclay will not crack or craze, even under extreme thermal shock. It will not corrode or change color; resists abrasion, acid and stains. And, Crane offers a most complete line of fixtures for ALL hospital plumbing requirements.

Why not talk to your hospital clients about Crane? You'll find that they agree with your preference for Crane hospital fixtures.



*Hygiene Pier Pattern Bath for Patients' Wards. Deeper than ordinary bathtubs. Accessible from three sides—or four in case of free-standing fixture. Makes it easy for nurse to wash patient. Made of famous Duraclay. Available with thermostatic mixer, mercury thermometer, shampoo fitting. Base not included.*



*Cornell Service Sink for everyday use. A general utility disposal sink commonly used on the operating floor, nursing and obstetrical departments. Flushing action is similar to that of a water closet. Base is not included.*

**CRANE CO.** 836 South Michigan Avenue, Chicago 5, Illinois  
VALVES • FITTINGS • PIPE • PLUMBING • KITCHENS • HEATING • AIR CONDITIONING

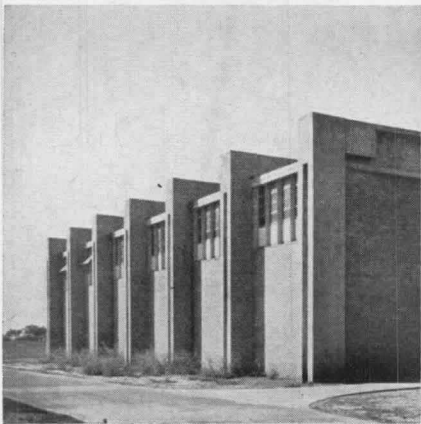

**LONGEST FREESPAN PRECAST GIRDERS SPAN SCHOOL GYM**

Precast concrete roof girders, believed to be the longest ever used, span 146 ft in a Springfield, Missouri high school gymnasium. Architect Richard P. Stahl based his choice of a structural system for the building both on appearance and on early estimates which indicated that the use of prestressed girders and precast concrete roof panels would permit spanning the area at a saving over other types of construction. Early in the design stage, Stahl and consulting engineer Eric C. Molke of Prestressing Research and Development, Inc., San Antonio, Texas decided upon a construction procedure that allowed the king-size girders to be placed by a simple application of regular prestressing equipment without tying up heavy cranes.

The girders were poured and prestressed on the ground, and raised between twin columns with the same jack used for prestressing. Frame continuity was introduced later by prestressing the raised girders to the columns. To form the groove and mortise joint used for

this connection, the beams were poured in place, with end blocks the same width as the combined columns, and a "tongue" extending between them. A 3/4 in. space was left between the girders and the columns by backing the plywood forms that lined adjacent column faces with 3/8 in. steel straps.

Because of the large positive bending moment at midspan, the upper flange of the girder continues at the same width as the columns and end blocks. The narrower bottom flange is shaped to accommodate the roof decking, and provided with reglets above slab level to receive flashing. The girders themselves vary in height from 5 1/2 ft at the column faces to 7 ft at midspan, and are stiffened by six vertical ribs in each. The 8 in. web thickness permitted draping the prestressing units from low in the bottom flange to two vertical rows at the supports.

When the concrete had reached its 7-day strength of 4000 psi., the girders were completely stressed on the ground.

**WHEN THE AIR SUPPLY IS VITALLY IMPORTANT**

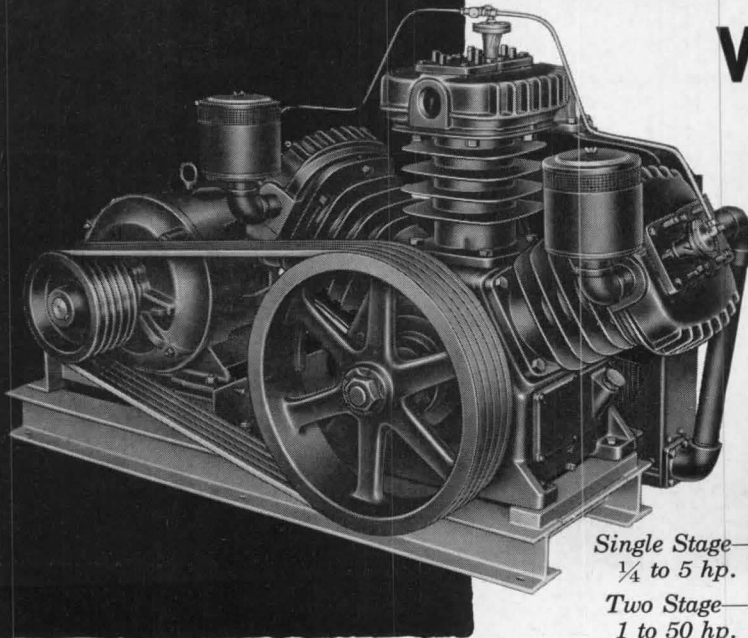

*Specify*  
**Curtis**  
*and Relax!*

Large fin area for quick and efficient air cooling—Timken Tapered Roller Main Bearing, adjustable for wear—Positive Centro-Ring pressure oiling system.

**Available for prompt delivery**

With 103 years of engineering and manufacturing experience "built-in" you can be confident that there are no finer air compressors on the market than Curtis.

Single Stage—  
1/4 to 5 hp.  
Two Stage—  
1 to 50 hp.

REMEMBER...YOU CAN COUNT ON

**CURTIS MANUFACTURING CO.**

OUR 103rd YEAR

**PNEUMATIC DIVISION**

1986 KIENLEN AVENUE • ST. LOUIS 20, MO.

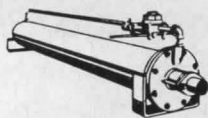

AIR CYLINDERS AND AIR HOISTS

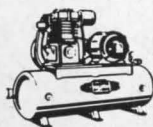

VERTICAL OR HORIZONTAL TANK MOUNTED COMPRESSOR 1/4 THRU 15 HP.

CM-24

The prestressing jacks were then placed on lifting yokes at the tops of the columns and used to hoist the girders. The 2 in. lifting rods were in two sections, coupled together, with a short steel anchor beam at the bottom to distribute the pull to four anchor bolts embedded in the concrete. After the girders had been raised, they were simply supported on a rocker bearing over the slightly rounded surface of a rail bulb while cranes placed the precast roof panels.

Girders and columns were finally connected by stressing 12-wire units threaded through holes at the top of the columns into corresponding holes in the girder end blocks. All units were grouted after prestressing to fill spaces in the flexible tubing. To provide lateral support for the girders, anchor plates along their bottom flange were welded to similar plates cast into the bottom of one rib of the concrete panels. The joint between the panel ends and the girders was then filled with mortar and covered with sloping concrete corner fill. In addition to increasing the stability of the roof system, this made it easier to apply the flashing which was later caulked into the reglets along the beams.

### AIR CONDITIONED SIDEWALKS FOR "OPEN AIR" SHOPPING



Air conditioned stores are old hat in Texas — now they're air conditioning the sidewalks too. San Antonio's North Towne Plaza shopping center has turned the 16 ft covered sidewalk fronting its stores into an air conditioned mall by glassing in the parking area side and installing 7½ hp air conditioning units in three adobe brick closets spaced around the walk. The result is an up-to-date version of the old open air bazaar. Merchants leave their doors open and use the area in front of their stores for display, with a reported increase in store traffic and sales of impulse items.

### FIRE RESEARCH FACILITY TO TEST BUILDING FINISHES

A fire technology research building recently constructed by Southwest Research Institute is the only one of its kind in the country that is available for industrial use. The research facility, a 20 by 40 ft insulated frame building lined with incombustible material and resting on a concrete slab, includes a 25 ft fire tunnel for evaluating materials used for interior building finishes. The fire tunnel is lined and has a removable cover on which materials to be evaluated are placed. Air is drawn through the tunnel at the rate of 200 feet per minute, with temperature and humidity carefully controlled, while two gas burners at one end simulate flame conditions that may develop in a severe fire. The action of the fire on materials being tested is observed through glass windows on the side, and records are made of the rate at which flame spreads, as well as the smoke density and heat generated at the exhaust end. When necessary, samples of the hot gases can be taken to check for toxicity.

(More Roundup on page 278)

## IMPORTANT REASONS WHY

**Architects - Engineers -  
Contractors and Owners**

**prefer the CURTIS 50 Ton  
PACKAGED AIR CONDITIONER**

**INSTALLATION EASIER:** Line assembled at the factory—eliminates expensive field labor.

**PERFORMANCE KNOWN:** Curtis units are run-in at the factory and guaranteed to deliver their rated tonnage. Assures a **BALANCED SYSTEM**.

**DELIVERY ON TIME:** Curtis can meet your delivery requirements, a decided advantage over multiple supplier delivery promises!

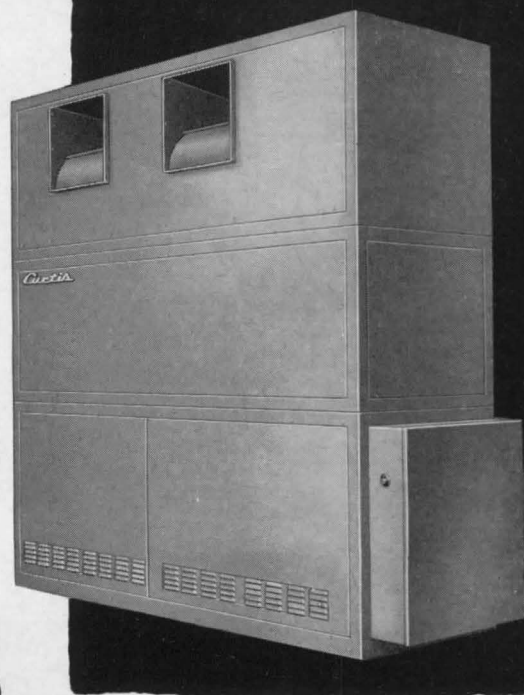

**MANUFACTURING CO.  
REFRIGERATION DIVISION**

1986 Kienlen Ave., St. Louis 20, Mo.

CM-23

CAN COUNT ON  
REMEMBER...  
YOU

**Curtis**

OUR 103rd YEAR

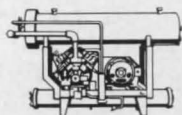

PACKAGED  
LIQUID  
CHILLER  
UP TO  
100 TONS



PACKAGED AIR  
COOLED UNITS  
UP TO 7½  
TONS

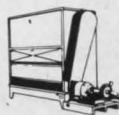

AIR HANDLING UNITS  
COOLING TOWER  
AND EVAPORATIVE  
CONDENSER  
TO MATCH

How  
*high velocity*  
solves problem of  
*flexibility*  
in the  
Medical Towers

Architects: Golemon and  
Rolfe, AIA, Houston  
Consulting Architects: Skidmore,  
Owings and Merrill, New York  
Consulting Engineers:  
Bernard Johnson and Associates  
General Contractor:  
Tellepsen Construction Co.  
Air Conditioning Contractors:  
Straus-Frank Company



When the new Medical Towers Building in Houston, Texas was planned, the key air conditioning problem was flexibility. Professional office areas had to be subdivided *after* the building was completed. Here's how an Anemostat dual duct high velocity air distribution system solved the problem.

As shown in the diagrammatic sketch, a system of perimeter take-offs from the hot and cold ducts enables each doctor to provide the exact temperature he wants. Temperatures in the various rooms of each suite of offices can be varied. Air distribution is draftless, comfortable, perfectly suited to tenants' needs.

The Anemostat All-Air High Velocity distribution system offers further important advantages. It can be used with smaller than conventional ducts. It can be installed in less time and at less cost. It requires no coils, thus eliminates leakage, clogging and odors.

**ARCHITECTS — Attention Please:**

Anemostat round, square and straightline diffusers with high velocity units are adaptable to a wide variety of architectural designs.

▼ Anemostat HPE units and duct connections installed in office before construction of ceiling and walls

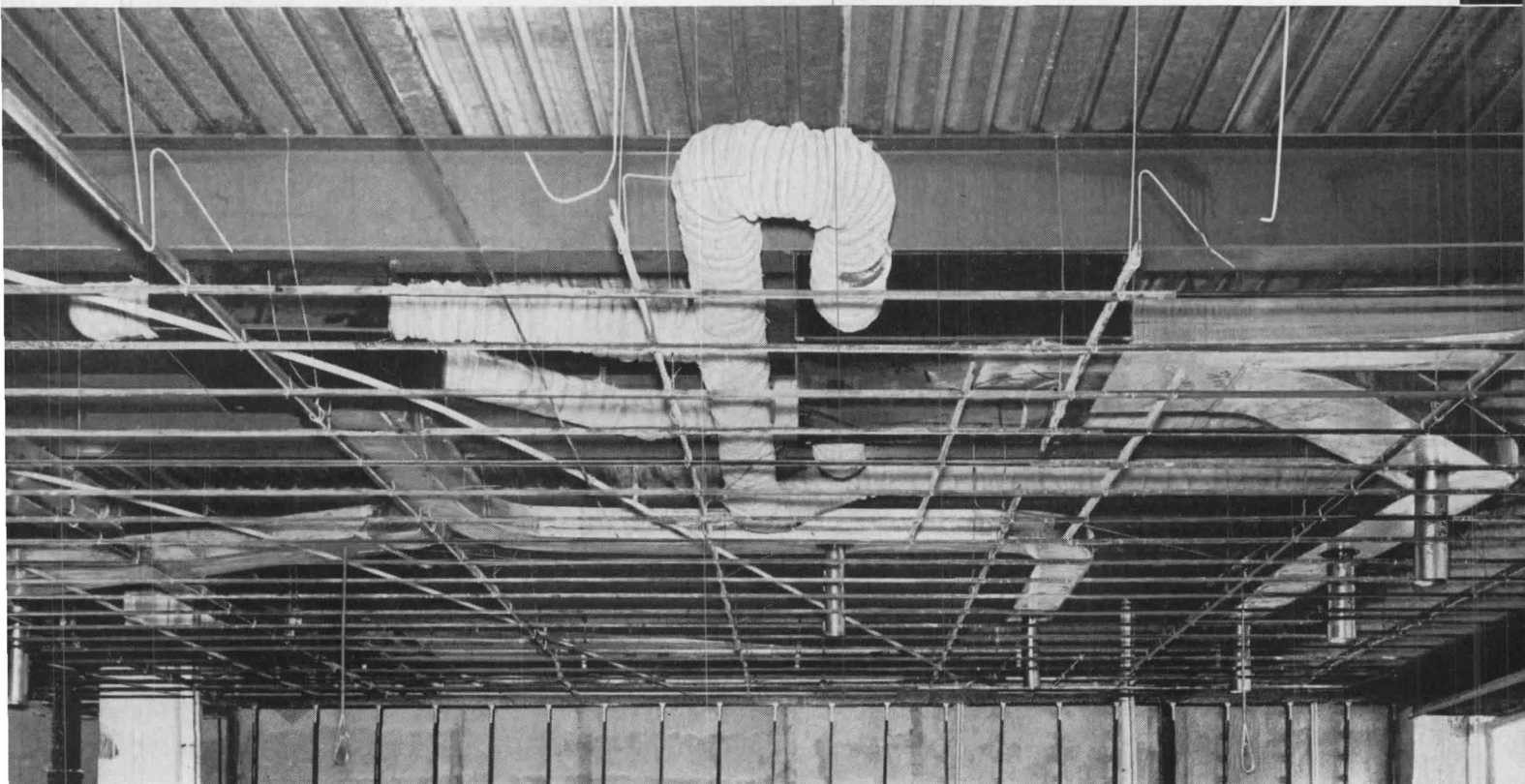

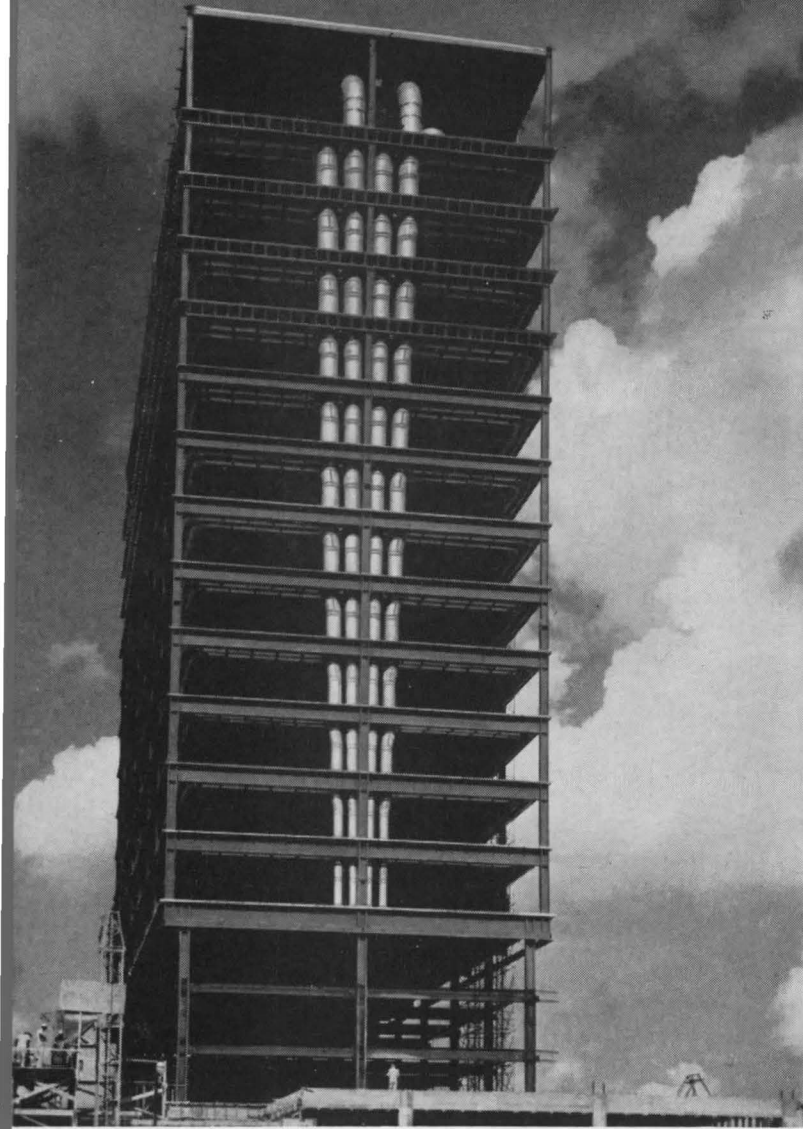

◀ Note how locating of hot and cold ducts saves space in new Medical Towers Building, Houston, Texas



View of lobby showing Anemostat Air Diffusers



View of professional reception room

◀ Layout of typical suite

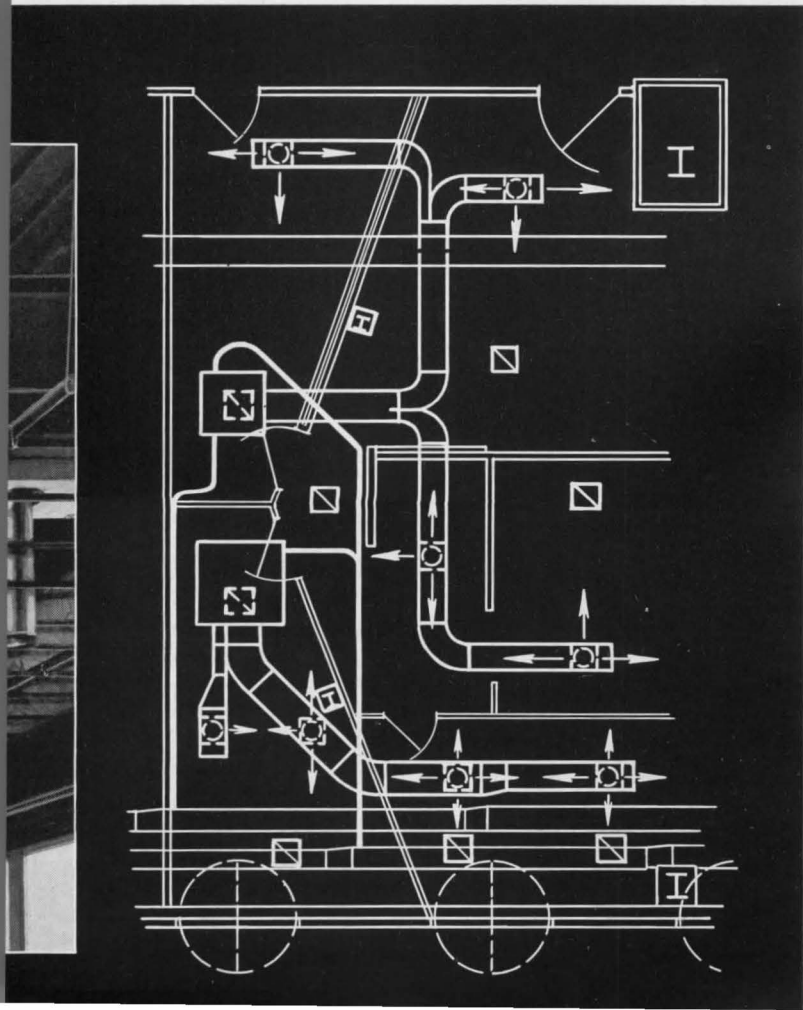

Write on your business letterhead for your copy of

**New Anemostat Selection Manual 60**

to Anemostat Corporation of America, 10 East 39 Street, New York 16, N. Y.

**ANEMOSTAT: The pioneer of All-Air High Velocity Systems**

(Continued from page 275)

NATURAL STONE CHALLENGES METAL CURTAIN WALL



The natural stone industry's answer to the metal curtain wall is demonstrated in two new state office buildings in Harrisburg, Pennsylvania which have thin curtain walls of limestone backed with cellular glass insulation. Architects Lacy, Atherton and Davis of Harrisburg devised a method of applying 4 in. thick slabs of Indiana limestone to a steel grid framework, their weight carried on steel angles at their base and their tops anchored. After the limestone was hung it was parged with a cement mixture, and the 2 in. blocks of cellular glass applied with a cold setting mastic. In a few areas relatively inaccessible from the inside, the insulation was installed free-standing and the limestone secured in place in front of it. A bead of sealing compound seals all the joints so that the insulation also acts as a vapor barrier. The interior surface is covered with a metal partition liner.

Particle Board Conference Held

An exhibit of some 300 samples of wood particle board and other new materials that provide outlets for leftovers from forest thinnings, lumbering and product manufacture was featured at the recently held international particle board conference. The two-day conference climaxed the second year of special surveys and studies of wood residue utilization techniques conducted by the Timber Engineering Company for clients in the lumber, particle board and wood-using industries.

(More Roundup on page 282)

IT PAYS TO HAVE GOOD CONNECTIONS

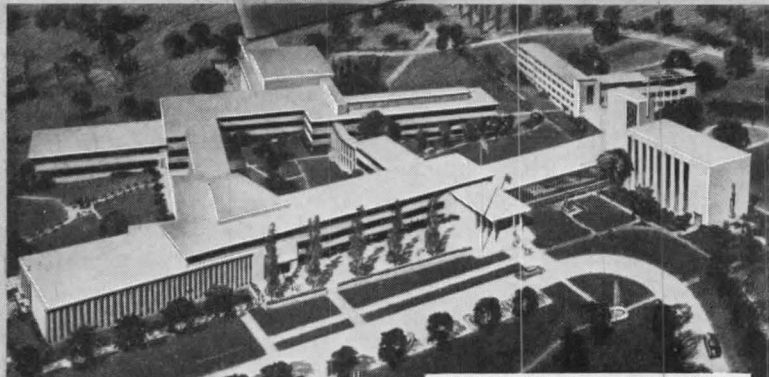

ST. XAVIER LIBERAL ARTS HIGH SCHOOL  
Chicago, Illinois

ARCHITECTS-ENGINEERS  
Noess and Murphy  
ELECTRICAL CONTRACTOR  
Emerson Comstock Co., Inc.  
HUBBELL SUPPLIER  
Englewood Electrical Supply Co.

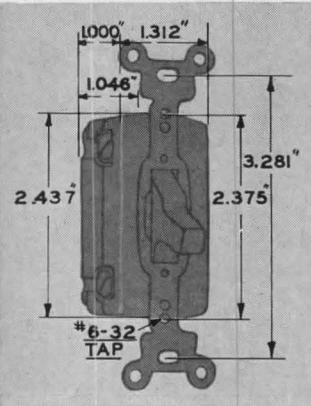

Dependable AC switch control is of vital importance in any fluorescent lighting installation where high levels of illumination require a large number of fixtures operated at full rated capacity. As in the beautiful school plant above, Topper AC quiet action switches are the ideal choice because they are designed to control many more fixtures than conventional switches, thus permitting control of *more fixtures with each switch*. Operation of heavier circuits (and fewer of them) results in lower wiring costs. Remember, too, that Topper switches are shallower, take up less room and are easier to install.

Detailed information on request



Cat. No. 1221  
20 amp.  
120-277 volt  
AC Switch

HARVEY HUBBELL, INC.

BRIDGEPORT #2, CONNECTICUT

QUALITY WIRING DEVICES

FACTORY WAREHOUSE  
LOCATIONS ASSURE  
NATIONWIDE STOCK  
AVAILABILITY

Bridgeport 2, Connecticut  
State and Bostwick Streets  
Chicago 7, Illinois  
37 South Sangamon Street  
Los Angeles 12, California  
103 North Santa Fe Avenue  
San Francisco, California  
1675 Hudson Avenue  
Dallas 7, Texas  
1111 Dragon Street



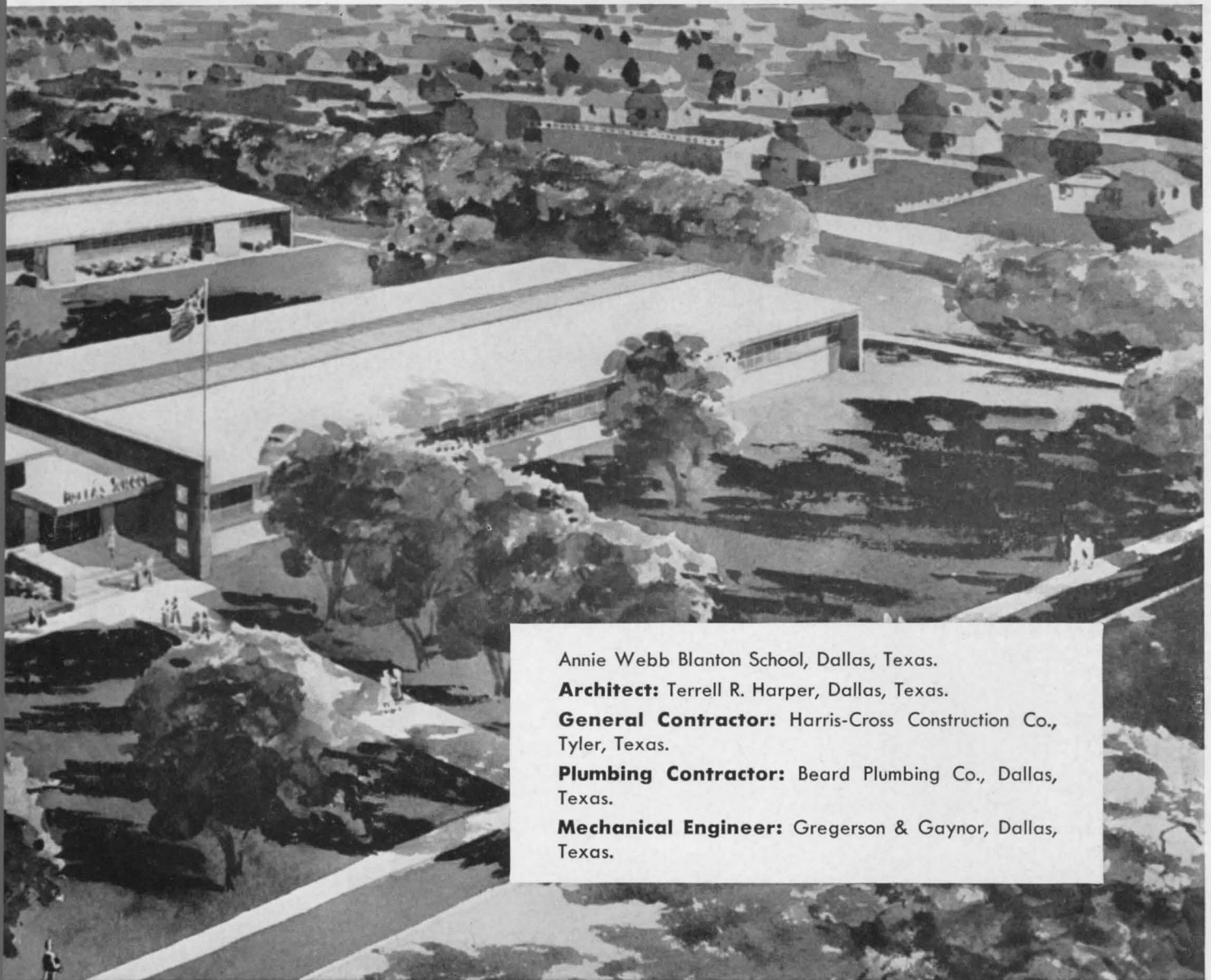

Annie Webb Blanton School, Dallas, Texas.

**Architect:** Terrell R. Harper, Dallas, Texas.

**General Contractor:** Harris-Cross Construction Co., Tyler, Texas.

**Plumbing Contractor:** Beard Plumbing Co., Dallas, Texas.

**Mechanical Engineer:** Gregerson & Gaynor, Dallas, Texas.

## for new Texas school

**Efficient sanitation** is a major factor in the selection of plumbing fixtures for today's schools. Equally important is rugged quality that will meet requirements for school installation.

We are proud that Eljer fixtures have been chosen for Dallas' handsome new Annie Webb Blanton School — and for so many other new buildings across the nation.

Eljer's unusually complete line — in vitreous china, formed steel and cast iron *plus* steel kitchens — can meet your most exacting requirements for either white or colored fixtures. Eljer brass fittings are completely renewable.

Our representatives will be glad to work with you on the plumbing fixture specifications for your projects. Please call on us at any time.

# ELJER

DIVISION OF THE **MURRAY** CORPORATION OF AMERICA

Three Gateway Center  
Pittsburgh 22, Pa.

 **ELJER** — the only name you need to know in plumbing fixtures

**TESTS CONFIRM DESIGN FOR "HOUSE OF TOMORROW"**

The Monsanto "House of Tomorrow" (AR, Aug. '56, p. 210) took a step toward realization when recent tests verified basic engineering calculations for its design. Assumptions about its structural behavior were based on small scale laboratory tests of many combinations of plastics and reinforcing materials, but this was the first test undertaken on full-scale components.



For the test sections, a combination of polyester resin and glass fiber reinforcement was selected. Two of the 8 by 16 ft bents which will form the shell of the house were cantilevered from a test frame and subjected to static and thermal loads up to twice the design limits. Static loadings in the form of water-filled drums were imposed in stages on both halves of the bent, separately and together. Maximum loads were found to be 110 psf on the floor section, 80 psf on the roof section. Thermal loadings, designed to test the frame connections and jointing details, consisted of hot water sprays which quickly raised the surface temperature of the sections from 34 to 114 deg F. The resulting 80 degree difference between roof and ceiling was equivalent to a uniform loading of 40-50 psf in the opposite direction from snow and wind loads.

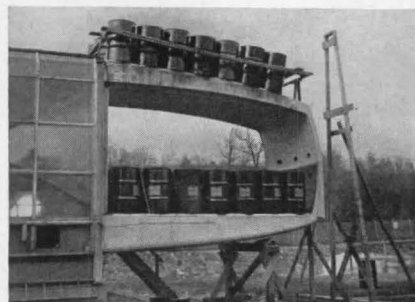

The five-month test program was planned and conducted by the engineering department of Monsanto Chemical Company's Plastics Division with professors A. G. H. Dietz, F. J. Heger and F. J. McGarry of M.I.T. as consulting engineers.

**3 quality lines, completely weatherproofed, make Miller sliding glass doors ideal**

**1 Aluminum "250 Series" for single glazing only.**

Snap-on glazing mold accommodates 1/4" plate or crystal. Fully Alumilited finish. "Magic-touch" hardware with Lucite pull.

**2 Aluminum "1000 Series" for interchangeable single and dual glazing.**

Converts from 1/4" plate to 1" insulating glass (or reverse) any time without disturbing framing installation. Fully Alumilited finish. "Magic-touch" hardware with lucite pull.

**3 The Steel Series for single or dual glazing.**

Made from heavy gauge Bonderized steel. Full-grip hardware with Lucite pull.

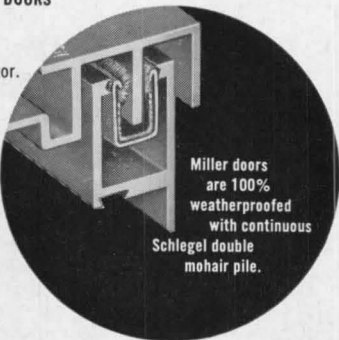
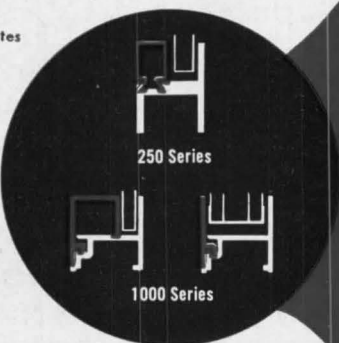
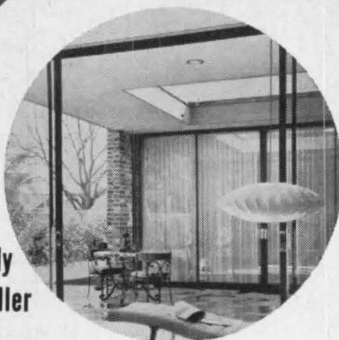

**Miller SLIDING GLASS DOORS**

Frank B. Miller Mfg. Co., Inc.  
3216 Valhalla Dr., Burbank, Calif.

Write for catalogs. See your Distributor.

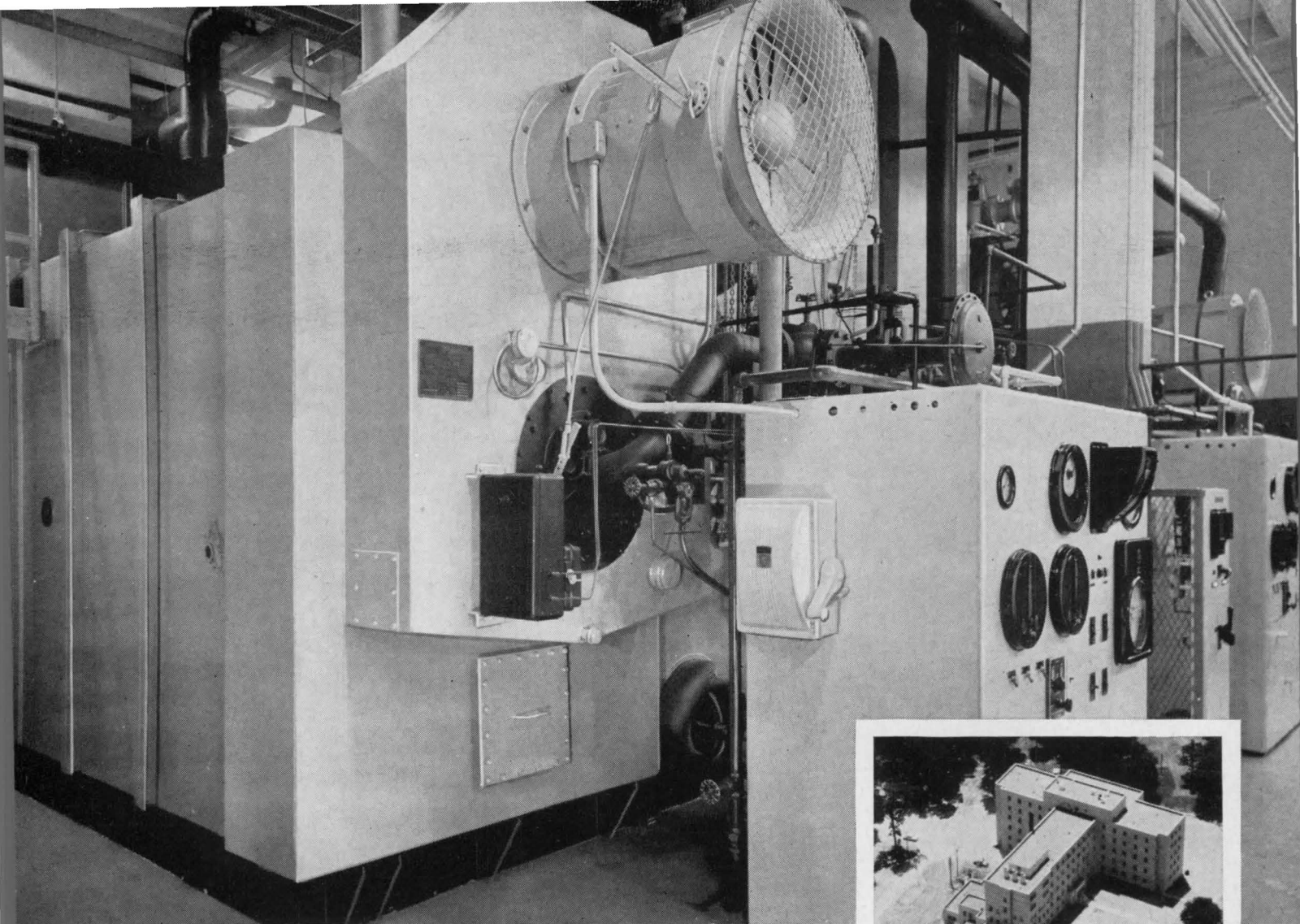

Dual unit installation of B&W Type FM Integral-Furnace Boilers at Barberton Citizens Hospital. Consulting Engineers: William E. Bodenstein and W. W. Shuster. Architects: Samuel Hannaford & Sons. Heating, Ventilating, Plumbing: T. O. Murphy Company.

## Low Cost Steam Does Many Jobs

### B&W 'PACKAGE' BOILERS SERVE BARBERTON CITIZENS HOSPITAL

Two B&W Type FM Integral-Furnace Boilers are the reliable source of plentiful, low cost steam that is put to many uses at Barberton Citizens Hospital, Barberton, Ohio. The gas-fired boilers, which can also use oil as a stand-by fuel, are automatically controlled to operate under minimum supervision.

**Combined Capacity** of the two units is 41,000 lbs of steam per hr, enough to supply an additional wing, should one be erected in the future. Both are "package" boilers, completely shop assembled. They only required service connections after installation.

**The 250-Bed** hospital, with a total of 560 rooms, uses steam for heating, sterilizers, a restaurant serving 37,000 meals a month, and a laundry that can handle 13½ pounds of linen per patient per day.

**Long Life**, low maintenance, reliability, continuity of operation, and efficiency have been proved for B&W Integral-Furnace Boilers in hundreds of installations in institutions and industry throughout

the nation. They provide maximum capacity in small boiler room space, high fuel economy, and economical, fast steaming. They have built a reputation for quick response to wide load swings.

**B&W Provides** a single responsibility in design, engineering, manufacturing, installation, and service through a national network of plants and engineers. For detailed information on B&W Integral-Furnace Boilers, write for Bulletin G-76D. The Babcock & Wilcox Company, Boiler Division, Dept. AR-3, 161 East 42nd Street, New York 17, N. Y.

G-841-FM



BOILER DIVISION



*Rhodesian Walnut,*

*background for elegance...a spirited graciousness*

■ Photographer-Illustrator Bob Christiansen, who in a few short years has carved a reputation for himself out of brilliant concept and daring execution, captures some of the sleek but homey "American" character of Rhodesian Walnut in the Stem veneer that backs this self-portrait. "There is something in the vigorous grain of this Rhodesian Walnut veneer that is radiant, comfortable, and at the same time provides a background perfect for an elegant setting." The same Rhodesian Walnut veneer by Stem that here says a thousand unspoken pleasantries for the photographer can be equally as eloquent for the architect. Through the catalytic artistry of the architect, rare wood paneling and graceful living strike up a happy match. Wherever a background of

fine wood is used, its noble presence is felt by all, welding substance and spirit into exciting unity. When rare woods from the forests of the world are used, there is a spirited graciousness—a strength and beauty that dwell in every ripple of its meticulously finished grain. And yet, beautiful wood is the essence of peace; it brings serenity to a room in a way that is all its own. Now, Stem brings you, through the magic of modern factory methods, all the nobility, splendor and lifetime permanence of the finest veneer that tradition knows. And you can afford to be generous with this wood, for the cost is low.

*Chester B. Stem, Incorporated*  
185 Grant Line Road New Albany, Indiana  
New York — Chicago — Dallas — Los Angeles

RARE WOODS  
FROM STEM



Could this  
happen to  
*YOUR*  
FLOORS?

ELIMINATE  
**FLOOR  
BUCKLING**  
with . . .

**Premoulded Membrane**

TRADEMARK

the industry's only **TRUE** vapor seal . . .

and

**CORKTITE** floor cushion.  
TRADEMARK

The installation of wood flooring on grade or subgrade slabs presents certain problems. The movement of free moisture and vapor transmission, from the site, through the slab and into the structure must be prevented. A "stacking of humidity" can raise the humidity to a level where a dewpoint can readily occur within the floor itself . . . buckling and rotting quickly follows.

Eliminate the two avenues of moisture migration by installing the following . . . first, "Premoulded Membrane" vapor seal should be installed directly over virgin, hard tamped grade or fill material to isolate the slab from moisture and vapor originating in the soil. "Premoulded Membrane" has a vapor permeance of .0066 grains per hour; is resistant to rot, mold and termites; is strong enough to withstand the pouring of aggregate and normal on-the-job abuse without puncturing; expands and contracts with the slab without breaking the seal; provides a monolithic vapor seal with mechanically sealed joints. Next, Corktite, the impermeable, resilient insulation with a thermal resistance of .48 BTU or less, should be installed as an underfloor cushion between the slab and finish flooring . . . this prevents a dewpoint within the floor and eliminates deterioration by condensation or ground moisture.

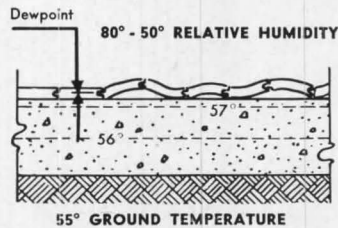

Construction without Vapor Seal or Underfloor Cushion—Active dewpoint causes rotting and buckling.

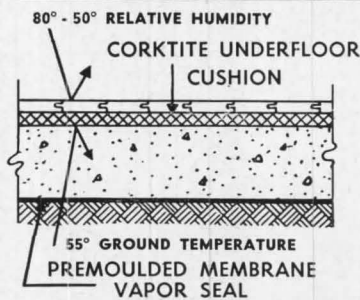

Construction with Vapor Seal and Underfloor Cushion—floors retain stability, dewpoint cannot be reached.

see our catalog in



or write for copy

Write today for complete information and your set of "Tech-Tips."



PRODUCTS FOR  
**SEALTIGHT** BETTER CONSTRUCTION

**W. R. MEADOWS, INC.**

4 KIMBALL STREET  
ELGIN • ILLINOIS

W. R. Meadows, Inc.  
Kimball St., Elgin, Illinois

Gentlemen:

Send me complete information and "Tech-Tips."

Have representative call.

NAME \_\_\_\_\_ TITLE \_\_\_\_\_

FIRM \_\_\_\_\_

ADDRESS \_\_\_\_\_

CITY \_\_\_\_\_ STATE \_\_\_\_\_

## THE RECORD REPORTS WASHINGTON REPORT

(Continued from page 360)

a "summary and future outlook." 190 pp., illus. NAS-NRC Publication No. 378. — \$4.00.  
**Floor-Ceilings and Service Systems in Multi-Story Buildings.** This conference had as its central theme the integration of the building structure and its service systems for the most efficient performance of the multi-story building as an environment for human activity. 18 major papers plus discussions. 150 pp. approx., illus. NAS-NRC Publication No. 441. — \$4.00.

**Modern Masonry: Natural Stone and Clay Products.** — \$4.50.

**Windows and Glass in the Exterior of Buildings.** In press.

Reprints of BRAB Reports to FHA

**Slab-on-Ground Construction for Residences.** NAS-NRC Pub. No. 385. — \$2.00.

**Effect of Automatic Sequence Clothes Washing Machines on Individual Sewage Disposal Systems.** NAS-NRC Pub. No. 442. — \$1.50.

**Installation of Wood Block Flooring by Adhesive Bonding.** NAS-NRC Pub. No. 443. — \$1.50.

**Performance Characteristics of Domestic Water Heating Equipment.** NAS-NRC Pub. No. 444. — \$1.50.

**Vapor Barrier Materials for Use with Slab-on-Ground Construction and as Ground Cover in Crawl Spaces.** NAS-NRC Pub. No. 445. — \$1.50.

**Anchorage of Exterior Frame Walls to Various Types of Foundations.** NAS-NRC Pub. No. 446. — \$1.50.

**Cracking of Concrete Face Brick and the Development of Data Necessary for the Establishment of Criteria for Its Manufacture and Installation.** NAS-NRC Pub. No. 447. — \$1.50.

**Protection Against Decay and Termites in Residential Construction.** NAS-NRC Pub. No. 448. — \$1.50.

Reprints of Federal Construction Council Reports

**Roof Decks and Built-Up Roofing.** No. TR-1. — \$1.00.

**Air Conditioning in Federal Buildings.** No. TR-2. — \$1.00. Out of Print.

**Warehouse Design.** No. TR-3. — \$1.00.

**Summaries of Two Research Reports on Plumbing Systems and Water Supply.** No. TR-4. — \$1.00. Out of Print.

**Selection of Windows.** No. TR-5. — \$1.00.

**Self-Contained Air Conditioners.** No. TR-6. — \$1.00. Out of Print.

**Space Allowances of Offices and Ceiling Heights in Office Buildings.** No. TR-7. — \$1.00.

**Pressure Drainage Systems for Buildings.** No. TR-8. — \$1.00. Out of Print.

**Climatic Data for Determining the Need for Cooling Equipment.** No. TR-9. — \$1.00.

**Packaged Type Boilers.** No. TR-10. — \$1.00. Out of Print.

**Electrical and Load Growth in Buildings.** No. TR-11. — \$1.00.

Other Publications

**Building Science Directory.** The beginning of a comprehensive guide to sources of information on research and technical developments in the building industry. In looseleaf form; pages to be added periodically. Free to BRI participating members; to non-members, \$2 a year.

Register of Members. For members only.

# . . . . . the man from *Smithcraft*

When you put his knowledge of lighting to work for you, your ideas turn into reality! His experience enables him to translate architectural concepts into effective lighting results. You can have confidence in his judgement because he knows how to adapt the flexibility of Smithcraft's line of lighting units into time-saving, economical solutions to lighting problems. Call him in to consult with you or your lighting engineers on any job on your boards . . . you'll find he knows blueprints and budgets as well as he knows lighting!

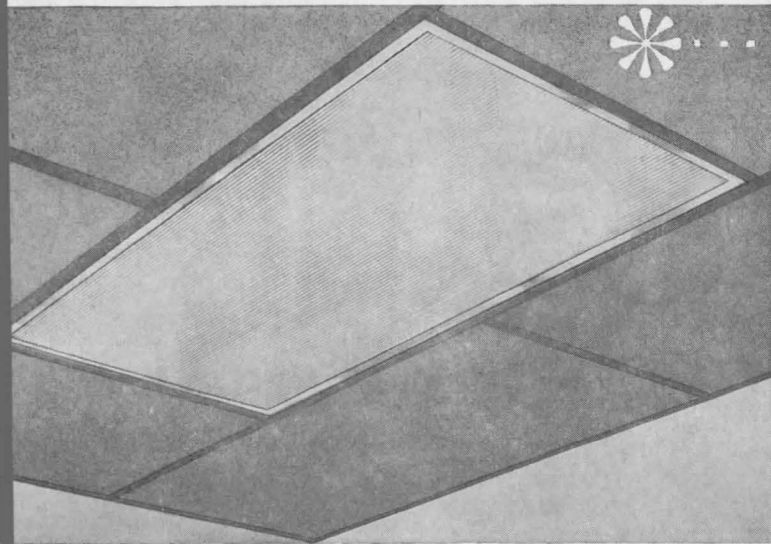

Smithcraft two-foot wide troffers are adaptable to today's most common ceilings. They are fast, easy and economical to install. There is a wide variety of shielding media available including Steel louvers (providing 30° x 30° shielding), Plastic louvers (42° x 42° shielding), Albalite glass, Corning Pattern #70 glass, Ribbed glass, Polycraft Plastic Dish and Acrylic Plastic.

Smithcraft, a leader in the progressive design and development of fluorescent lighting fixtures manufactures a complete line of units specifically designed to meet a wide variety of lighting applications. The Smithcraft catalog contains pertinent and useful information on this line of fixtures and is a valuable aid in the design of lighting layouts or in ceiling planning. Make sure your copy is in your file. If it isn't, let us send you one.

***Smithcraft***  
**L I G H T I N G**  
 CHELSEA 50, MASSACHUSETTS

## . . the 24" wide troffer from *Smithcraft*

Extremely versatile, architecturally integrated recessed lighting, Smithcraft two-foot wide troffers permit wide freedom in the creation of interesting and functional lighting patterns. They present a modern, trim, clean appearance free from light leaks or blemishes and with no visible catches, hinges, or screws. In glass or plastic-shielded units, a clean expanse of shielding is uninterrupted by cross-braces. Doors open or close with simple upwards pressure (patented) and simply lift off for maintenance. In louvered units, louvers are held by Smithcraft's patented Duo-Cam hangers. Louvers hinge from either side and are removed without tools or loose parts.



Smithcraft 2'-wide Metro Troffers provide 75 footcandles of extremely even illumination throughout Beerman's Department Store, Dayton, Ohio. Metro Troffers are lay-in troffers for inverted "T" Grid ceiling systems.

PLEASE ATTACH TO YOUR BUSINESS LETTERHEAD and mail to  
*Smithcraft* LIGHTING, CHELSEA 50, MASS.

AR-3

NAME \_\_\_\_\_ TITLE \_\_\_\_\_

- Please send me the monthly publication, "Light Side of the News", so that I can keep in touch with the latest trends in lighting.
- Please send me "YOUR CEILING PLANNING COMES TO LIFE", a complete handbook on one and two-foot wide SMITHCRAFT ARCHITECTURAL TROFFERS.
- Please send me the complete SMITHCRAFT CATALOG, containing data on "America's Finest Fluorescent Equipment".

# Now...all three from *Hamilton!*



## laboratory equipment

—a complete range of laboratory units and service fixtures to equip secondary school or college laboratories.

catalog 218



## arts and crafts furniture

—a fresh new line of highly functional furniture and storage units for today's art, drafting and shop classrooms.

catalog 219

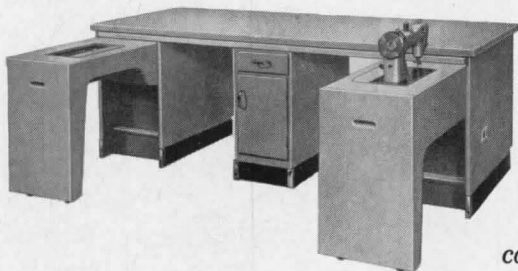
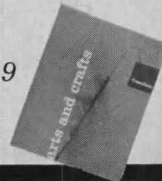

## home arts furniture

—everything from Stout sewing tables to built-in oven kitchen cabinets for modern homemaking instruction centers.

catalog 220



Three new lines of school equipment handsomely illustrated, fully described, with sample assemblies, floor plans, and a wealth of other information—from an old hand in the school equipment field. That's what you get in these three all-new Hamilton catalogs. Write for your free copies today—Hamilton Manufacturing Company, Two Rivers, Wisconsin.

# Hamilton

SPECIALIZED SCHOOL EQUIPMENT

## THE RECORD REPORTS REVIEWING THE RECORD

**Footnotes to architectural history, from the ARCHITECTURAL RECORD of 1907:**

**The A.I.A. at fifty:** "The next convention of the American Institute of Architects," announced the January RECORD, "to be held in Washington City January 7, 8 and 9, 1907, will commemorate the fiftieth anniversary of the Institute. . . . It is proposed to make this a notable meeting. A bronze memorial tablet, containing the names of the founders of the Institute, will be unveiled in the Octagon, commemorating the occasion. During this meeting the Institute will inaugurate the custom of presenting a gold medal for distinguished merit in architecture. The first medal will be presented to Sir Aston Webb, the architect of the Victoria Memorial, London, who received the gold medal of the Royal Institute of British Architects and a knighthood during the past year."

**A national study of municipal parks,** a small and local hint of Mission-66-type efforts, and of Federal involvement in public welfare, was urged by one G. A. Parker, speaking at a convention of the American Association of Park Superintendents reported in the January issue. "The indications," said Mr. Parker, "are that within a generation or so about one-half of the nation's children will be born and brought up under urban conditions. . . . It is therefore imperative that city conditions be made such that children city born and bred may have such environments as will enable them to grow into healthy and

*(Continued on page 372)*

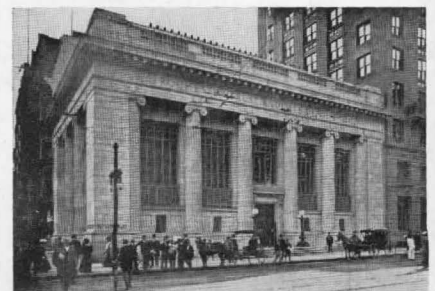

*Reporting on the Rochester Trust & Safe Deposit Company by York & Sawyer in the January 1907 issue, the editors observed the firm's debt to McKim, Mead & White, who had trained the younger architects, but noted "a greater departure from historical precedent"*



**... to heat every room in your building!**



## sub-freezing air to heat an entire building

**DRAMATIC ADVANCE MAKES HEAT PUMP PRACTICAL—WITHOUT SUPPLEMENTAL HEATING**

The development by York engineers of the first practical heat pump to use below-freezing outside air promises convenient, more economical year-round air conditioning with a single system. No longer will supplementary strip heating equipment be needed in areas where winter temperatures drop below freezing.

**The big difference** in the York heat pump is that it takes advantage of a long-utilized refrigeration technique, compound compression. The system is operated by thermostatically controlled valves. These valves guide hot or cold water in and out of the system while compressors automatically move from single-stage compression into compound compression when the temperature drops below a certain point. Now that the high-operating-cost problem of auxiliary strip heating,

needed where temperatures drop much below 32° F., has been eliminated, builders and owners can offer customers year-round air comfort at lower annual cost.

**Electric Utilities** faced with uneconomical air conditioning load factors will now be able to profitably promote the heat pump above the Mason-Dixon line. Until now the high operating cost of the air-source heat pump has limited application in Northern areas. But elimination of heat pump capacity deficiencies at low temperatures and removal of the very low load factors of strip heaters makes the new system attractive to both user and utility. For full details on the York heat pump write: York Corporation, subsidiary of Borg-Warner Corporation, York, Pennsylvania.



*the quality name in air conditioning*

HEADQUARTERS  
FOR MECHANICAL COOLING  
SINCE 1885

# YORK

C O R P O R A T I O N

SUBSIDIARY OF BORG-WARNER CORPORATION

Architect: La Pierre, Litchfield & Partners; Consulting Electrical Engineer: Gustave B. Weiser;  
 Electrical Contractor: Heckler Electric Co.; Electrical Distributor: Chugg-Carlin, Inc.

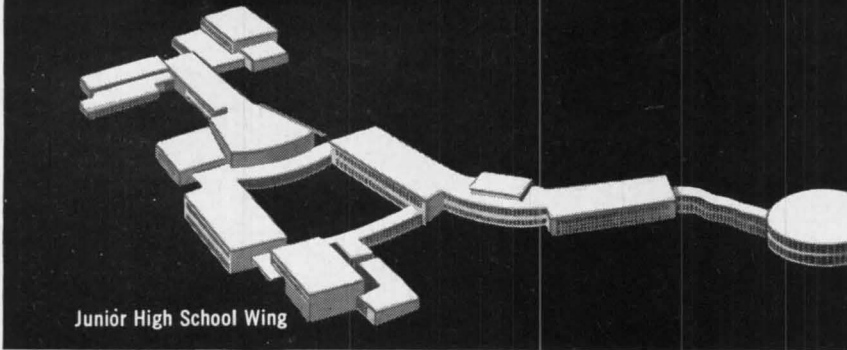

Junior High School Wing

lighting  
 design by

mc Philben

for the magnificent new  
 Great Neck High School

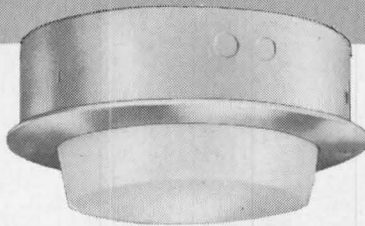

... a wholly new concept in school architecture and quality building.

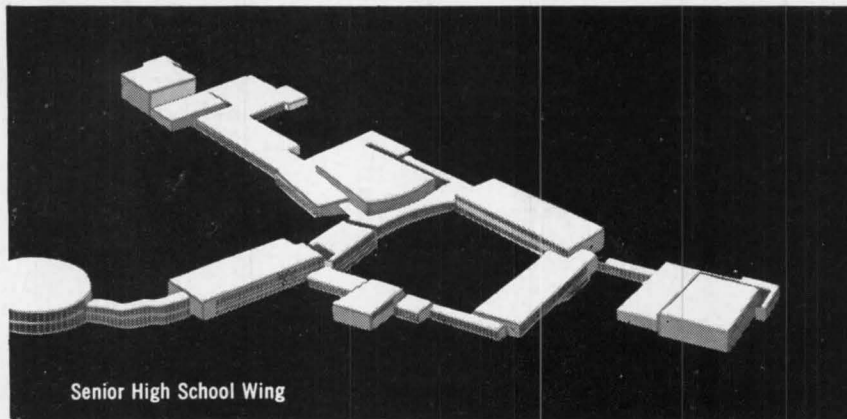

Senior High School Wing

McPhilben 43-24 recessed weather-tight downlights will light the exterior corridors of this superb new school in Great Neck, N. Y. Only 3½ inches deep, the 43-24 housings are sturdily constructed of 16 gauge galvanized steel. The gleaming satin finish of the face plates will resist all corrosive elements, thanks to the anodized cast aluminum construction. And, mcPhilben's exclusive Sealume gasket of neoprene rubber will assure permanent weather-tight maintenance-free operation. Your mcPhilben representative has full details about the 43-24 and other mcPhilben recessed weather-tight downlights, both square and round. Contact him or write to mcPhilben Lighting Co., 1333 Willoughby Avenue, Brooklyn 37, N. Y.

Representatives in major cities • Stocked by electrical wholesalers

## THE RECORD REPORTS

### REVIEWING THE RECORD

(Continued from page 368)



"Chateau Schwab," modeled by architect Maurice Hébert after Chenonceaux, was considered in the February issue an excellent example for other billionaires to follow, at least in respect to its site in the middle of a "whole block of ground on Riverside Drive" in New York

vigorous men and women, physically, mentally, morally and spiritually, and the function which is to have the most important bearing on this work is the park." Mr. Parker asked that the Federal government investigate the popular use of parks and prepare comparative studies.

**The risk a pioneer runs** is failure, as the architects of the Bixby Hotel at Long Beach, Cal., learned. The February RECORD noted engineer John E. Leonard's analysis of the failure of the reinforced concrete building: "The steel reinforcement was found insufficient to do its work of transmitting the tensile strains to the proper members. Girders were run in one direction only, and these parallel to the greatest spacing of the columns which revealed the absence of any adequate tie at floor levels. This means no lateral bracing for floors or walls, and that the floor panels are enclosed by girders on two sides instead of on all four and double reinforced, as is customary in good reinforced concrete construction." On the other hand, an engineer who read this piece recently was heard to mutter that times haven't changed so much.

**Building Type, 1907:** said the March Notes and Comments column, presenting photographs of two riding academies built for the Vanderbilts, "Now that well-to-do people spend a large part of the winter, as well as much of the summer, in the country, the practice of adding riding academies to the other buildings connected with large estates is

(Continued on page 376)

Again in 1957 Architectural Record subscribers will receive, besides their regular May issue, a bonus mid-May issue featuring *the largest and most colorful presentation of America's finest architect-planned houses ever made by a magazine.*

*Record Houses of 1957* will be more than a unique permanent record of architectural taste and achievement in the current year. It will be a rich source of design ideas from the planning boards of many of America's most talented architects . . . some widely known, others whose work will be published for the first time.

In addition, highly visual presentation of each house, coupled with a clear statement of the problems and purposes behind its planning, will make *Record Houses of 1957* an ideal tool for opening clients' eyes to ways in which architecture can serve their individual needs, aspirations and way of life.

**DON'T MISS THESE OUTSTANDING FEATURES:**

- *A selection of twenty-five of the best architect-planned houses of the year in the \$20,000 to \$60,000 price range. One hundred pages—many in full color—presenting the work of such architects as Edward Barnes; Mario Corbett; David, Brodie & Wisniewski; Philip Johnson; Carl Koch; George Matsumoto; George Nemeny; Eliot Noyes; Minoru Yamasaki.*
- *Major elements of house design—Including "close-ups" of the design of bathrooms, kitchens, fireplaces, stairs, entrances, storage and built-ins.*
- *A comprehensive editorial round-up of *New Products for the House and Manufacturers' Literature.**
- *A full-range presentation, in the advertising pages, of 1957 materials, equipment and furnishings for the quality house.*

**NATIONWIDE BOOKSTORE DISTRIBUTION IN JUNE**

More than ten thousand copies of "Record Houses of 1957" have been reserved for bookstore distribution. They will expose a significant segment of the house building and buying public to the benefits of architectural counsel in planning a new house.



**ARCHITECTURAL RECORD**

F. W. Dodge Corporation  
119 West 40th Street, New York 18, N. Y.  
OXford 5-3000



## THE RECORD REPORTS

### REVIEWING THE RECORD

(Continued from page 372)

becoming more and more common, and it may be expected that during the next ten years the architects of such estates will have many buildings of this class to design. They can, undoubtedly, be made useful in more ways than one. . . . They could, for instance, be used at times for indoor tennis courts; and it is probable that before long some rich man will carry out the idea of including within one large structure a combination of casino and riding academy, which would contain the means of enjoying all sorts of indoor games and sports, such as riding and driving in the ring, squash and tennis courts, billiards, bowling and a pool."

**The impermanence of architecture:** in one part of the March issue, a staff writer quoted James Renwick, architect of St. Patrick's Cathedral, who believed that "the business of an American architect was to build things that would stand and be presentable for about 30 years, after which they were fairly sure to yield to 'the principle of vicissitude and the effluxion of things.'" And in the Notes and Comments department of the same issue, another writer, deploring the wholesale razing of a number of New York's early skyscrapers, asked: "The fame of the painter, the sculptor or the architect has always had the unperishable witness of his works, but will not the fame of the American architect like that of an actor be preserved only by tradition or by written memorials? A hundred years from now, may it not be that the habitation of the reputation which an American architect leaves behind him will not consist in stone and steel buildings, but in the dim and moth-eaten pages of some ARCHITECTURAL RECORD?"

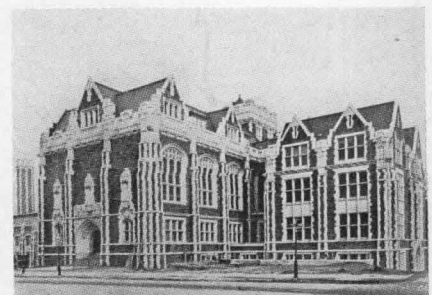

The new campus for the City College of New York, still under construction, was reviewed in the March 1907 issue; George B. Post was the architect

(More news on page 380)



**ELKAY**  
A REFLECTION OF GOOD TASTE

## Stainless Steel BAR SINKS

### INEXPENSIVELY PROVIDE A TOUCH OF LUXURY IN HOMES, CLUBS OR BARS

A lifetime of service, convenience and beauty is built right into every plan when ELKAY Bar Sinks are specified. Gives you a wider imaginative freedom for home design . . . gives you complete freedom from worry for institutional use. ELKAY Bar Sinks of solid stainless steel cannot chip or crack . . . are so easy to clean and to keep clean . . . softly reflect surrounding color schemes.

Check this table . . .

### A WIDE RANGE OF SIZES MEET EVERY REQUIREMENT

#### Single Bowl Flat Rim

SIZE O.D.	SIZE I.D.
14" x 14"	12" x 12"
18" x 14"	16" x 12"
11½" x 14"	9½" x 12"

#### Two Bowl Flat Rim

28" x 14"	12" x 12"
22½" x 14"	9½" x 12"

#### Single Bowl—Ledge Type

SIZE O.D.	SIZE I.D.
14" x 17"	12" x 12"
18" x 17"	16" x 11½"
11½" x 17"	9½" x 12"
14" x 14"	12" x 9½"

#### Two Bowl—Ledge

28" x 17"	12" x 12"
22½" x 17"	9½" x 12"
27½" x 14"	12" x 9½"

Also available in three bowl models • See Sweet's <sup>24b</sup> Elk or write for full information

Illustrated is a single bowl bar sink with back ledge suitable for gooseneck faucet.

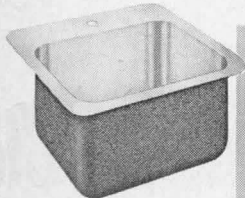

**ELKAY**  
MANUFACTURING COMPANY

1874 S. 54th Ave. • Chicago 50

The only complete line of stainless steel sinks . . . Lusterton®, Elkay Custom, Pacemaker, Starlite, Design U-2000, Sit-down®.