

★ ART DEPARTMENT

ART MAGAZINE

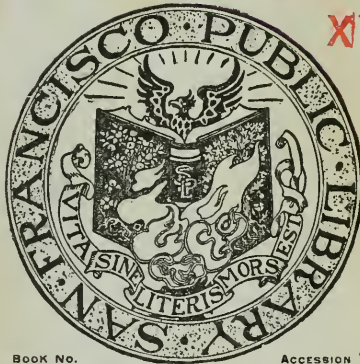

BOOK No.

ACCESSION *

720.5 Ar24¹³⁵

476157

NOT TO BE TAKEN FROM THE LIBRARY

FORM 3427-SM-8-38

C



Digitized by the Internet Archive
in 2010 with funding from
San Francisco Public Library

THE

ARCHITECT

AND

ENGINEER

OCTOBER 1938

**STREAMLINED
CONSTRUCTION
DEMANDS**

**W A S P E E D I N
CONCRETE
HARDENING**



*This New
20 page*
**MANUAL TELLS
HOW TO GET IT**

If you have not received
a copy your request
will be promptly
complied with.

A "Pacific" Product
sold by Building
Materials Dealers.



Produced by

SAN FRANCISCO
LOS ANGELES

PACIFIC PORTLAND CEMENT COMPANY

PORTLAND
SEATTLE

COASTWIDE SERVICE

x720.5 135
Ar24

The OCTOBER 1938

476157

ARCHITECT & ENGINEER

Fred W. Jones, Editor

Mark Daniels, A. I. A., Associate Editor

Edgar N. Kierulff, Assistant Editor

CONSULTING BOARD OF EDITORS

Architectural—

- Arthur Brown Jr.
- Frederick H. Meyer
- Timothy L. Pflueger
- Will G. Corlett
- Harry Michelsen
- Lewis P. Hobart
- David C. Allison
- Gordon B. Kaufmann
- Harris C. Allen
- Glenn Stanton

Engineering—

- H. J. Brunner
- L. H. Nishkian
- William Adrian
- Wm. H. Popert
- Homer N. Hadley
- John J. Gould
- Geo. E. Atkins

Advertising Manager—

J. Leslie Meek

Architects' Reports—

Vernon S. Yallop

Contents

FRONTISPIECE

Residence of Mrs. James Irvine, Altadena 20
H. Roy Kelley, Architect

TEXT

Exhibition of Architecture 17

Program of State Convention 18

California Architects to Celebrate Decennial 19

Honor Awards 21
Paul Robinson Hunter, Architect

Highlights 31
Harry M. Michelsen, Architect

Origin of State Association of California Architects 35
John J. Donovan, Architect

Relation of State Association to Institute 37
Robert H. Orr, Architect

Legislation Needed to Eliminate State Bureaucracy 39
Lester H. Hibbard, Architect

More Business For Architects 43
Chester H. Miller, Architect

Unification Most Desirable 45
Albert J. Evers, A. I. A.

Is Architect Losing His Independence? 49
Richard Neutra, Architect

California State Board of Architectural Examiners 51
A. M. Edelman, Dean of Architects

Co-ordination 52
Harris C. Allen, F. A. I. A.

Specifications For Structural Concrete 53
Joseph A. Kitts

ARCHITECTS' WORK

Gardner A. Dailey 16-46	Roland I. Stringham and A. J. Evers 34
H. Roy Kelley 20-21	Arthur L. Herberger 36
Roland E. Coate 22-23	Jas. H. Mitchell 38
Marston & Maybury 24	Jas. H. Anderson 40
Sumner M. Spaulding 25	Fred L. Confer 42
Winchton L. Risley 25-27	Miller & Warnecke 44
Palmer Sabin 28	Wm. W. Wurster 47
Wallace Nelf 29	B. M. Clark and D. B. Clark 48

THE ARCHITECT AND ENGINEER, INC., 68 Post Street, San Francisco, EXbrook 7182. President, K. P. Kierulff; vice-president, Frederick W. Jones; secretary, L. B. Penhorwood. Los Angeles office, 832 W. Fifth Street. Published on the 12th on each month. Entered as second class matter, November 2, 1905, at the Postoffice at San Francisco, California, under the Act of March 3, 1897. Subscriptions, United States and Pan America, \$3.00 a year; Foreign countries, \$5.00 a year; single copy \$.50.

RUNNING FIRE

by
MARK DANIELS, A.I.A.

Catching Up

It is most encouraging to learn that the Department of Immigration is catching up, even though that be with a speed that is barely perceptible to the naked eye. They have got down to the 75 year class, so we must not be downhearted.

Yes, they have caught up with old Gin Huie who, for the last 75 years has been living with us. Perhaps the Immigration Bureau worked from the top down, starting with the centenarians, which would account for their having barely reached old Gin. Otherwise, how could they have jumped right over the heads of those who have been here only eight years or multiples of eight. Nor could they have taken deportables in alphabetical order because both G and H come after "B"; or do they know that, it is remotely possible, however, that the prohibitionists thought there were some significance in the fact that a Chinese first name is the surname and that he was the father of a certain type of distillery. As a last explanation it is possible that the Bureau feels that a man must throw bombs, organize strikes, teach communism, insult the flag, incite labor trouble and receive pay from foreign socialists for 75 years before he can be eligible to trial for deportation. Anyhow, it appears that old Gin Huie, who has done none of these things, must go, so the logical conclusion is that, by going backward like a crab, we have just reached the 75 year class.

★ ★ ★

What's In A Name?

The last word in futility these days is an effort to gain attention to either written or spoken word on any other subject than the fate of Czecho-Slovakia. The fact that that country is the still-born child of the Versailles treaty does not register. The ever-ready argument that we would not like to have the Japanese come over here forcing suki-yaki down our throats and pinning obis like bustles on our women, completely annihilates the more sane and calm contention that living conditions in California would not be greatly changed if our state were ruled by the Governor of Oregon or Nevada.

But whenever I hear the haranguers mouthing the polysyllable, "Czecho-Slovakia," I recall the quip of G. K. Chesterton who, upon being asked what he thought of changing the name Bohemia to Czecho-Slovakia, said, "Imagine saying 'last night I was out with some rare old friends and we had a most delightful Czecho-Slovakian evening.'"

★ ★ ★

He Found His Place

Professor Leon J. Richardson of the University of California found that his research work and preparation of his knowledge laden lectures called for an environment that was less noisy and more conducive to the company of his particular mood. He therefore built himself what, in these modern days of the intellectual hoyden, would be called a penthouse, lined the same with semi-soundproofing material and otherwise arranged the interior so that noises as well as light and noisy persons could not reach him. There he spent happy hours writing lectures and his tomes, uninterrupted by the superficial and the curious.

One day he asked a friend to his study. The gentleman walked around on the quiet carpet, observed the soundproofing, the heavy drapes, the shuttered windows and the felt-locked doors and finally turned to Professor Richardson with a quiet comment, "My dear Leon, at last you have found your place. Here you can sit and prepare your lectures, your essays and write your volumes and no one will be the wiser."

★ ★ ★

Playing Possum

Elsewhere in this issue will be found the announcement of the annual party of the American Society of Civil Engineers, which convention meets under the auspices of Ralph Tudor, Chairman. A hurried perusal results in a return reading which finally leaves the impression that the engineers have been playing possum! In these many years, there are laughs in it. As a matter of fact there are several laughs in it, and quite a bit more humor than can be found in the squeak of a slide rule.

The item in the announcement

stating the engineers of the two great bridges over San Francisco Bay and the Golden Gate are three theorems up on Euclid seems to me to be a bit of an understatement. As a matter of fact it would be no exaggeration to say that Charles H. Purcell is four Q. E. D.'s up on the whole world.

★ ★ ★

A Flaw in the Honor System

Orrin Kitt McMurry, dean emeritus of Boalt Hall, was discussing honor systems in law school and other classes in the University of California. He was asked how the honor systems were and whether they should be continued. His reply was "Oh, it works admirably in almost every case. We find that the law students carry out the theory of the honor system to the letter with one exception. The curious thing about this exception is that in every examination but one their conduct is perfect; but in the examination in ethics they cheat like hell."

★ ★ ★

Rat Proofing

After a diligent search I have at last put one over on the offices of this magazine and prepared a poser for the State and Federal Governments.

The Foxcroft Bldg., S. F., has in its employ a cat yeapt Susie. Susie is one of the oldest employees of the building, having been working now for seven years. Her salary is \$1.50 per month which is sufficient to give her adequate food and a comfortable place to live. Occasionally the management passes on a bonus, of catnip, because in the manager's words, "she's worth her weight in gold." Susie is official rat and mouse catcher of the 68 Post Street building. When a renter reports to the management that there is a mouse in his cupboard Susie is installed in the room that night; the next morning she presents the evidence of her work to the superintendent.

Anyhow, I am glad to point out to Fred Jones, my boss, that an up-to-date architectural magazine missed a modern method of rat-proofing. But, how the devil are they going to take care of the Old Age Benefits, Unemployment Insurance and Social Security Number of Susie?



● Substantial reduction of the "dead load" in any structure automatically results in lower construction costs. Concrete Joist Construction definitely reduces "dead load" without sacrifice of permanence, beauty or strength.

frame and foundation, with a further reduction in material costs. The forms used in Concrete Joist Construction mean faster erection and real economy. Standardized dimensions of these forms mean simplicity and lower labor costs.

REDUCE "DEAD LOAD"

Concrete
Joist Con-

A USEFUL
HANDBOOK

struction saves concrete and steel, as well as time and labor. Smaller quantities of these materials are required to carry a given load for a given span. Reduced "dead load" results in a lighter structural

"Concrete Joist Construction"—a valuable Handbook of standard specifications, design data and load tables—will be sent to you upon request. Check the many important advantages of this modern method. Specify it in your next project.

CONCRETE REINFORCING STEEL INSTITUTE

Builders Building, (Department 510), Chicago, Illinois

Forms Department Members:

- | | |
|--|--|
| Hugh J. Baker & Company Indianapolis, Ind. | Golsmith Metal Lath Company . . . Cincinnati, Ohio |
| Ceco Steel Products Corporation . . . Omaha, Nebr. | Hausman Steel Company Toledo, Ohio |
| Colorado Builders' Supply Co. Denver, Colo. | National Concrete Metal Forms Corp., Newark, N. J. |
| Concrete Steel Company New York, N. Y. | Steelform Contracting Co., San Francisco, Calif. |
| Danley Brothers Company Cleveland, Ohio | Truscon Steel Company Youngstown, Ohio |

CONCRETE JOIST CONSTRUCTION

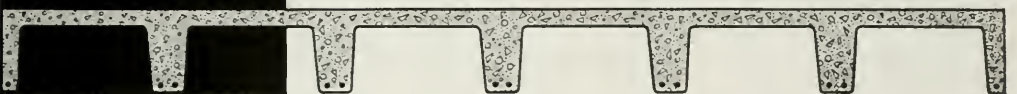

ABOUT HEDGES

By BERNIECE ASHDOWN

BECAUSE of its many uses in gardens both informal and formal, the hedge always has had a prominent place in the history of garden art. Even in the earliest gardens to which we have access, we find hedges used to beautify the garden itself and to screen out undesirable surroundings.

For informal settings, hedges may consist of a line of untrimmed shrubs or trees; the rough texture of plants blends well with informal surroundings and is effective when used as a screen.

Formal hedges require a fine even texture and should be carefully aligned and clipped. They are used to advantage as a border for walks or flower beds or to create a vista in a garden or along a driveway. When a hedge is planted in a straight line along a boundary, niches for statues may be clipped at intervals.

Topiary work often is used in formal gardens where closely clipped hedges predominate. Simple figures—balls, cubes or cones—may be clipped without the aid of a guide, but the more elaborate shapes—birds, animals and intricate geometric figures—require a wire form. Since the figures lose their identity when they are neglected, topiary should be used only in gardens where constant care is available.

The prices of hedges vary according to localities and with the varieties used, but they are considerably less expensive than walls. Besides the annual pruning and an application of fertilizer every year or two, there is very little cultural routine with hedges.

The shape in which a hedge is trimmed is of little importance as long as it is simple and in keeping with the character of the garden and the architecture of the house. Often they are trimmed into a conical form, widening gradually from the bottom to the middle and narrowing again toward the top. In climates where there is a great deal of snow, this method is advisable since square-topped hedges are damaged by the weight of snow.

Care in preparing the soil and planting the hedge will pay large dividends. The spacing of the plants depends upon the variety used and upon whether or not a quick effect is desired. Spacing of plants for large hedges varies from one foot to two or three feet. Small border hedges of dwarf boxwood may be placed as close as six inches, but the plants will develop better if they are spaced eight to ten inches apart.

Where plants are to be less than two feet apart, usually it is best to dig a continuous trench rather than individual holes. The soil in the bottom of the trench should be loosened and well fertilized. Good rich top soil should be packed around the roots of the plants, and care should be taken to prevent raw, disintegrated fertilizer from coming directly in contact with the roots.

Before selecting plants for a hedge, it is well either to make a careful study of the varieties which are hardiest in your particular locality or to obtain the advice of an expert. The special requirements of location, soil and climate as well as the character of the house and garden should be taken into consideration.

If the garden is situated where it faces the prevailing winds it is advisable to plant wind resisting material. Monterey cypress (*Cupressus macrocarpa*) is excellent for this purpose. It grows well even along the sandy seashore.

Hemlock (*Tsuga Canadensis*) makes an especially beautiful impenetrable hedge. It stands pruning well and has a fine, even texture.

American arborvitae (*Thuja occidentalis*) is much used and very attractive. It does best in moist places but will grow in any good soil. Care must be taken in selecting hardy, vigorous plants or they are apt to die out in spots. Judicious pruning in the spring of the year is required in order to produce a thick growth.

Yew (*Taxus*) grows very slowly but its fine, even texture and rich coloring are unsurpassed. Some of the magnificent yew hedges which are admired today in the gardens of England were planted late in the seventeenth and early in the eighteenth century.

English holly (*Ilex aquifolium*), a shrub too well known to require an introduction, makes splendid hedges. It grows very slowly and unfortunately is not hardy in some localities.

There are several outstanding flowering hedge plants. Cockspur thorn (*Crataegus Crus-galli*) is used extensively in France and England. It has the advantage of being self-protecting as well as attractive. Its small, white flowers come in spring and are followed by bright red berries in fall.

In many places Japanese Quince (*Cydonia japonica*) is successfully used. It has deep green leaves and brilliant blossoms which come into full bloom early in the spring, and make a spectacular display.

The Russian Oleaster is not so well known as it deserves to be. It is tall and erect, having splendid silvery green foliage. Its yellow flowers are born in late spring and are followed by yellow berries. A list of hedge plants would not be complete without Privet (*Ligustrum*). There are many varieties, deciduous and evergreen.

California privet (*L. ovalifolium*) is much used in some latitudes but is subject to frost damage in cold climates. *L. vulgare* grows more slowly but is generally considered a better hedge plant. It has small evergreen foliage of rich texture. *L. coriaticum* is an attractive dwarf variety having thick waxy foliage, creamy-white flowers and blue berries.

European beech (*Fagus sylvatica*) makes

a tall, quick growing hedge which can be kept at any desired height. It has bronze gold leaves which persist all winter.

Hornbeam (*Carpinus caroliniana*) is another splendid quick growing hedge material. It may attain a height of forty feet if it is not trimmed, but it may be kept at a desired height.

Boxwood (*Buxus*) is the finest evergreen hedge for low inner garden hedges. Barberry (*Berberis Darwinii*) is also excellent for this purpose. It produces yellow blossoms in early spring. Snowberry (*Symphoricarpos albus*), which has small bell shaped flowers and white waxy berries, and Lavender (*Lavendula*) are also suitable.

Phone GARfield 1164

Hunter & Hudson

Consulting Engineers

DESIGNERS OF HEATING
AIR CONDITIONING
VENTILATING AND WIRING
SYSTEMS, MECHANICAL
AND ELECTRICAL EQUIP-
MENT OF BUILDINGS

41 SUTTER STREET
ROOM 710

San Francisco

California

What will an
AGENCY ACCOUNT
do for me?



Let us answer this question for you by sending you our interesting booklet, *An Introduction to Agency Service*, describing the modern, economical way to handle securities.

Just ask for Booklet M-2

**CROCKER FIRST
NATIONAL BANK**
OF SAN FRANCISCO
California's Oldest National Bank

ANNOUNCEMENT

The entire elimination of all flush valve noise from Sloan Royal, Naval, Crown and Star Valves is now obtainable by the use of Sloan *Quiet-Flush* equipment, a new and dramatically efficient product which assures absolute quiet.

This *Quiet-Flush* equipment will be furnished, when so ordered, with new Royal, Naval, Crown, or Star Valves at a small additional cost. Moreover, it may be applied easily and simply to all old installations of the same valves, making possible complete quieting and modernization for a nominal sum.

Sloan *Quiet-Flush* equipment is the result of skilled research and exhaustive tests. It combines the best features of previously used methods with new, improved principles *exclusively Sloan*.

You may now have genuine Sloan quality combined with genuinely quiet operation on both *new* and *old* installations. Send for complete descriptive folder on *Quiet-Flush* equipment.

SLOAN VALVE CO., CHICAGO

PULSE OF THE READER PLYWOOD ISSUE

Dear Mr. Editor:

I want to compliment you on the very beautiful Plywood edition of **The Architect and Engineer**.

I knew that this would be an interesting issue and that you would do a good job, but I did not appreciate what a really attractive issue you would have. I think this is one of the finest yet put out on Plywood.

Very truly yours,

PHIL GARLAND.

Oregon-Washington Plywood Co.
Portland, Ore., Sept. 20, 1938.

USEFUL NUMBER

Dear Mr. Editor:

A very useful issue—your September Plywood Number. You are doing splendid work for both the architectural and engineering professions.

HARRY MICHELSEN,

Architect.

San Francisco, Sept. 24, 1938.

PRACTICAL INFORMATION

Dear Mr. Editor:

Mr. Converse has just brought in to me the first copy I have seen of your September issue. Will you extend to your editorial staff my congratulations on the very fine job you have done in covering the uses of Douglas Fir Plywood as a modern building material.

While I am not an architect, I can't help but feel that there will be no one among your subscribers who gets this September issue but what will be much better informed and find a great deal of practical information about Plywood.

Sincerely yours,

McCANN-ERICKSON, INC.,

Vernon R. Churchill,

Pacific Northwest Manager.

Portland, Oregon,
September 20th, 1938.

A GRAND JOB

Dear Mr. Editor:

The September issue is here and we think that you have done a grand job. We are all very much pleased with the splendid manner in which you handled all of the Plywood information.

CHAS. E. DEVLIN.

Portland, Ore., Sept. 24, 1938.

A REAL PUBLIC SERVICE

Dear Mr. Editor:

With a 22-page Housing Portfolio in its current issue, Life Magazine launches a major program to inform potential home owners of America not only on the amazing technological progress in housing over the past decade but also on the vastly enlarged

financial aids available to the prospective home builder or purchaser. . . This long-range undertaking is predicated on the belief that a basic factor in the failure of America's long-awaited housing boom is lack of public understanding of the progress made and financial facilities available, that with hundreds of thousands of renters well able to build homes of their own, hundreds of thousands of home owners well able to build better homes, the problem is neither one of need nor opportunity, but of public knowledge.

The study embraces the following points:

1. Life has selected four **actual** families, each representing a different income group, \$2,000, \$3,000, \$5,000 and \$10,000, widely separated geographically in Atlanta, Philadelphia,

Los Angeles and Minneapolis. Life has gone into their **present** homes, discussed their housing needs, wants, ambitions, invited them to make their individual housing problem a laboratory test tube.

2. Life has identified, in each of their communities, an **actual** plot of land, available at so many dollars.

3. Eight of America's foremost architects were commissioned to design **actual** homes for this **actual** land for these **actual** families. Two alternative houses have been designed for each family, one by an architect best known for the traditional style, one by a leading modernist. These men are: Aymar Embury II, Harrison and Foulhoux, H. Roy Kelley, Richard Koch, Edward D. Stone, Royal Barry Wills, Frank Lloyd Wright and William Wilson Wurster.

4. **Ground has already been broken** for construction of a number of these houses. Projects are **now** under way in Pittsburgh, New York City, Milwaukee, Washington, Los Angeles, Boston, Chicago, Richmond, and San Francisco.

5. **First steps in home financing** are dealt with lucidly and simply in the Life Housing Portfolio.

6. This is no isolated effort, but the initial move in a consistent program of practical informative housing studies, based on actual case histories of living American families, worked out in the test tubes of actual home construction under varied types of income levels, land prices, labor and materials costs in the major geographic zones of the U. S.

Building costs of 1938 average a good 10 per cent below the "great normal year of 1926." The 1938-model houses of America present evidence of technological progress as dramatic as that which the 1938 automobile has manifested. Yet the building industry remains stagnant, despite the fact that with a few hundred dollars for cash down payment hundreds of thousands of families might begin ownership of homes today.

It is our belief that the program is one which will capture not only the imagination of the architects and builders of America, the fiscal groups and agencies working in this great field, but also of America's economists, sociologists, and leaders of opinion who know full well the need, the opportunity, and the possibilities of such an undertaking as this. . . .

Sincerely,

OTIS PEABODY SWIFT.

Executive Offices of LIFE
New York, Sept. 21, 1938

*A few hours
a few dollars*
AND
Sealcon
WILL MAKE YOUR
BASEMENT
DRY

SEALCON forms a water-resisting seal for basement walls and floors, brick, stucco or any other masonry. Just paint it on, inside or outside, to any wet or dry surface. One coat gives lasting protection . . .

conquers
dampness
and seeping
water. A
perfect
base, or
mixture, for
oil paint.

EASIER
TO APPLY
THAN PAINT

ASK DEALER
LISTED
BELOW
ABOUT



Sealcon
GUNN, CARL & CO.
Distributors
SAN FRANCISCO
20 Potrero Ave. UNDERHILL 5482



CERAMIC VENEER.... The Modern Facing.

TECHAU COCKTAIL BAR

San Francisco, Calif.

WILLIAMS & GRIMES
Architects

UNIT BUILT FIXTURE CO.
Contractor

The architects have combined character, beauty and utility in their modern feeling and rich color of Ceramic Veneer. The satiny black Ceramic Veneer and gold metal trim used in this building make an entrance of importance. This adhesion-type finish, a versatile material available in almost any conception of form and color, brings new freedom of design to the architect's interpretation of your problem.

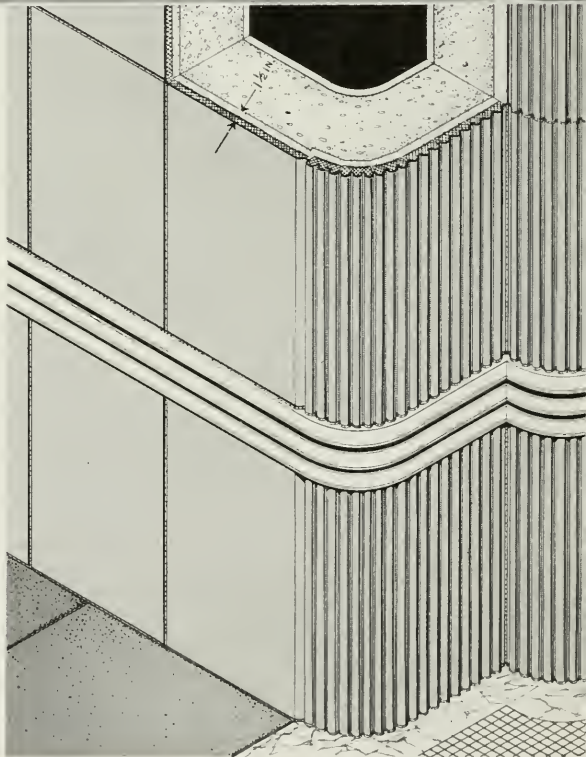

GLADDING, McBEAN & CO.

San Francisco

Los Angeles

Oakland

Portland

Seattle

Spokane

Vancouver, B. C.

AN EXHIBITION



SPRAL STAIRWAY DETAIL
SANDNER & DALEY ARCHITECT

OF ARCHITECTURE

THE Northern California Chapter of The American Institute of Architects is holding an exhibition of architecture at the San Francisco Museum of Art which will continue up to and including October 23rd. While the exhibition is sponsored and is being carried out by the local Institute Chapter, all licensed architects in the Northern District, comprising the whole region North of the Tehachapi were invited to submit examples of their work from which a selection of particularly outstanding designs has been made.

The particular aim of those charged with the task of getting up the exhibition was to bring forcibly and dramatically before the public a representative review of interesting and meritorious works of architecture consistent with the contemporary outlook and at the same time reflecting a broad front of appeal both in type of design and manner of execution.

In line with the above aim the design of the exhibition itself has been a matter of the utmost concern. Ernest Born, noted architect and designer, formerly associated with The Architectural Forum of New York and author of a number of brilliant works in the architectural and industrial design fields, was put in full charge of the selection, arrangement and presentation of the material. Dr. Grace McCann Morley, Director of the San Francisco Museum of Art, has placed several galleries at the disposal of the Chapter and has worked with it in every way to help make the exhibition both vigorous and appealing.

It is noteworthy that this whole showing has been conceived somewhat in the light of an impersonal movement and that while the authorships of the various buildings exhibited will be published it will not be stressed in a way to detract from the central idea, that this is a coherent body of architectural works, both highly imaginative and in excellent taste. It is indeed in all respects worthy of the fine reputation in such matters that California has so justly acquired.

The Museum is open from 12 noon to 10 P. M. week days, 1 P. M. to 5 P. M. Sundays.

Unusual features of the exhibition from the display standpoint are the almost exclusive use of very large photographs which bring the visitor "into" the picture in a rather startling way. These are hung on a staggered wall built into the gallery which carries also large scale plans and descriptions emphasizing the salient points of the various designs.

In the December issue of this magazine, Mr. Born will describe the exhibition in detail, giving readers the benefit of his experience, at times somewhat irritating, in designing and successfully presenting the undertaking. The illustrations will be of work shown at the exhibition, making an issue that should be outstanding for excellence of material and uniqueness of presentation.

Program - - 1938 Convention

STATE ASSOCIATION OF CALIFORNIA ARCHITECTS

Fairmont Hotel - - San Francisco

THURSDAY—OCT. 13

- Joint meeting of Executive Boards and State Board of Architectural Examiners.
- 5:00 P. M.** Registration of Delegates.
- 6:00 P. M.** Stag dinner, Frederick H. Meyer presiding.
Board members, advisors, committee chairmen, and all delegates who wish to attend or submit subjects to the Board for its final consideration.
- 8 to 10 P.M.** Joint meeting of Executive Boards.
Proposed resolutions must be submitted for consideration of the Resolutions Committee.

FRIDAY—OCT. 14

- 9:00 A. M.** Registration of Delegates.
- 9:30 A. M.** Convention convened, Harry Michelsen presiding.
Committee reports, resolutions, business discussion.
- 12:30 P. M.** Luncheon, Gwynn Officer, Vice-President Northern Section, presiding. Guest Speaker.
For delegates, members of the Building Industry and ladies.
- 2:00 P. M.** Business program, Gordon Kaufmann, Vice-President Southern Section, presiding. Program under the direction of G. Vincent Raney. Meeting open to the public.
Ladies' entertainment; cards or auto trips, and tea.
- 5:00 P. M.** Northern Section Advisory Council meeting to elect members-at-large to the Executive Board.
Meeting of California Society of Architectural Draftsmen.
- 7:00 P. M.** Cocktails.
- 8:00 P. M.** Banquet, Harris C. Allen presiding. For delegates, draftsmen, Producers' Council, members of the Building Industry and ladies.
Dancing, entertainment and pageant.

SATURDAY—OCT. 15

- 9:00 A. M.** Regional Conference of the Sierra Nevada District Chapters of the American Institute of Architects, Albert J. Evers presiding.
- 10:00 A. M.** Business session. George Riddle, president Southern Section, presiding. Report of Resolutions Committee.
Installation of officers. Adjournment.
- 1:30 P. M.** Trip to the Golden Gate International Exposition.
Exhibit of Northern California Chapter, A. I. A., at San Francisco Museum of Art. Golf, for those that must.

* * * * *

FAIRMONT HOTEL—CONVENTION RATES

Single rooms	\$3.50 per day and up
Two in one room, double bed	5.00 per day and up
Two in one room, twin beds	6.00 per day and up

PERIODICAL DEPT.



COCKTAIL BAR
FAIRMONT HOTEL
SAN FRANCISCO

CALIFORNIA ARCHITECTS TO CELEBRATE DECENNIAL

TEN years of achievement will be the keynote of the Tenth Anniversary of the State Association of California Architects to be celebrated as a part of its 1938 Convention, commencing Thursday, October 13, and continuing three days at the Hotel Fairmont, San Francisco. A large representation of architects from all sections of the State is expected and no detail will be overlooked to make the affair a success.

To further commemorate the Association's birthday, a considerable portion of this number of **The Architect and Engineer** is devoted to special articles dealing with the early history of the organization, its aims and subsequent accomplishments, its ambitions for the future. One of the first State Associations to be formed in the country, its growth has been little short of phenomenal until today it is recognized as foremost in membership and influence among the other State Associations and Societies in the United States. And yet, as compared with the age of the A. I. A. it is still a child with greater things in store before it will have reached maturity.

In the pages that follow you will want to read

President Harry Michelsen's review of the year, which he chronicles with characteristic clarity and enthusiasm.

Lester Hibbard minces no words when he draws attention to the urgent need of a change of policy in the selection of architects to design State buildings. Under the present rule private architects have no chance whatsoever, a condition Mr. Hibbard believes should be corrected by immediate legislation.

Chester Miller writes about "More Business for Architects" and points out the lamentable failure of the average architect to interest himself more in the other fellow's business.

Other especially prepared articles for this number will give you a good perspective of just what our prominent architects are thinking in this changing world with its amazing realities and uncertainties.

The pictures are of "Honor Award" houses in Southern California, selected by a jury of architects named by the Los Angeles Chapter, A. I. A. Limited space unfortunately prevents publication of all the houses named in the jury report. Likewise the illustrations of Northern California work.



Photo by Haight

Southern California Chapter, A. I. A. Honor Award

RESIDENCE OF MRS. JAMES IRVINE, ALTADENA, CALIFORNIA
H. ROY KELLEY, ARCHITECT



Photo by Haight

RESIDENCE OF MRS. JAMES IRVINE, ALTADENA, CALIFORNIA
H. Roy Kelley, Architect

THE architects of Southern California are pleased to present for publication in this issue of *The Architect and Engineer* some of the best examples of their residential work executed from 1933 to 1937. The number of fine houses submitted for judgment in the last Honor Awards Competition of the Southern California Chapter of The American Institute of Architects was a surprise, as few realized how many well designed houses succeeded in getting themselves built during the long years

HONOR AWARDS

Southern California

Architects favor

American Colonial and
English Georgian Styles

By PAUL ROBINSON HUNTER, Architect

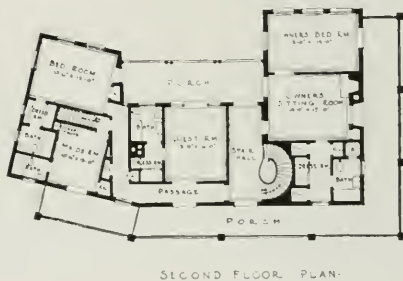
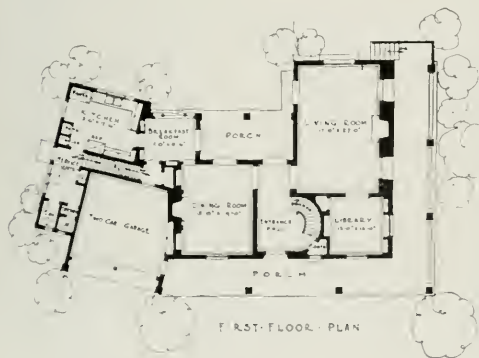
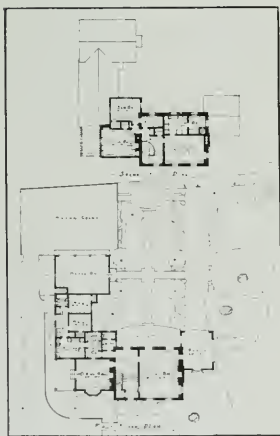



Photo by Haight

Southern California Chapter, A. I. A. Honor Award

GARDEN VIEW, RESIDENCE FOR MR. AND MRS. ARTHUR SMILEY, BEL AIR, CALIFORNIA
 Roland E. Coate, Architect



FIRST AND SECOND
 FLOOR PLANS
 RESIDENCE FOR
 MR. AND MRS. ARTHUR
 SMILEY,
 BEL AIR, CALIFORNIA

of quiet that pervaded the architectural offices. The jury, consisting of Messrs. Clarence A. Tantau of San Francisco, John Frederick Murphy of Santa Barbara and Herbert J. Powell of Los Angeles, spent four full days in examining and visiting the houses submitted, and of the 110 entries 39 were given Honor Awards while an additional 25 were held for special exhibition.

The houses receiving recognition have for the most part followed the established plan arrangements and design features of Southern California work, and have not ventured into the less well-known bypaths and trails now being travelled by William Wurster and Gardner Dailey in the North. The fact that the Mediterranean style is still a force is instanced by the honor accorded to the charming Italian home of Mme. Amelita Galli-Curci, and by the sprinkling of awards given to houses with Monterey porches and balconies. The bulk of recognition, however, went to the suave adaptations of the American Colonial and English Georgian styles, with their freshly whitewashed brick, green shutters and smart low pitched gable roofs.

Respecting work of more modern character, that receiving recognition is a house decidedly Japanese in feeling, which, unfortunately, was designed by a man without a license—bringing up once more that painful question of what the profession should do



PATIO AND GUEST HOUSE FROM
PORCH, RESIDENCE FOR MR. AND
MRS. ARTHUR SMILEY, BEL AIR,
CALIFORNIA

Roland E. Coate, Architect

with talented men who cannot meet the requirements of the State Board.

No small amount of credit for the merit of residential work must be given to the landscape architects who designed the settings for the houses, and it seems to me that our friends, the photographers, are all too frequently making more of the landscape frames than of the houses they are photographing.

Excellence in furniture craftsmanship and in interior design were also acknowledged by the jury.

From San Francisco came an entry that gave both color and gayety to the exhibition. Samples of textiles, skillfully mounted, were presented by Dorothy Liebes, accompanied by photographs of the rooms in which they were used. Mrs. Liebes is Director of Decorative Arts at the Golden Gate International Exposition.



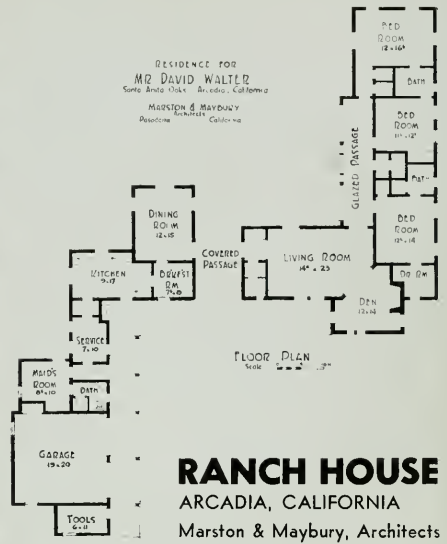

RANCH HOUSE
ARCADIA, CALIFORNIA
Marston & Maybury, Architects



Southern California Chapter, A. I. A. Honor Award

RESIDENCE OF DAVID WALTER, SANTA ANITA OAKS, ARCADIA, CALIFORNIA
Marston & Maybury, Architects



Photo by Dapprich

Southern California Chapter, A. I. A. Honor Award

RESIDENCE OF MR. AND MRS. SUMNER M. SPAULDING, BEVERLY HILLS, CALIFORNIA
 Sumner M. Spaulding, Architect



THE TWO INTERIOR VIEWS ARE OF THE ENCLOSED PATIO, TAKEN FROM WITHIN. A PART OF BOTH ENDS OF THE PATIO IS ROOFED. THE VIEW ACROSS THE TABLE IS LOOKING UP PEAVINE CANYON AT THE END OF WHICH THE HOUSE IS PLACED.



Southern California Chapter, A. I. A. Honor Award

HOUSE FOR H. S. PARSONS, SAN MARINO, CALIFORNIA
Palmer Sabin, Architect



DETAIL OF ENTRANCE

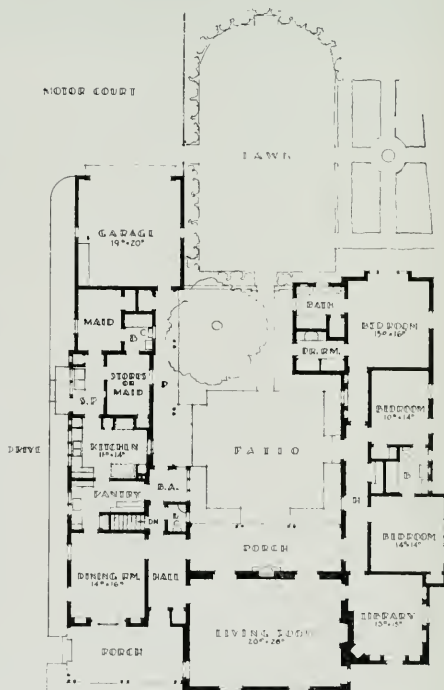

PLAN



Photo by Haight

Southern California Chapter, A. I. A. Honor Award

WINTER HOME OF AMELITA GALLI-CURCI, WESTWOOD, CALIFORNIA
Wallace Neff, Architect



VIEW FROM PASSAGE WAY TO GARDEN, WINTER
HOME OF AMELITA GALLI-CURCI, WESTWOOD,
CALIFORNIA

Wallace Neff, Architect
Florence Yoch and Lucile Council,
Landscape Architects

THREE INTERIORS

By HAROLD W. GRIEVE, A. I. D.

Textiles by Dorothy Liebes



RESIDENCE OF
MISS MIRIAM HOPKINS,
Beverly Hills, California



HIGHLIGHTS

President of State

Association Reviews

Year's Progress

By HARRY M. MICHELSEN, A. I. A.

SINCE our last convention we have sincerely endeavored to enhance the interest of our fellow architects to analyze the acute problems that have developed during recent years in the various departments of governmental and private agencies and to curb the ambitions of avaricious groups to obtain control of industry by mercenary methods. The enthusiastic cooperation displayed by the united membership of our Association confirms our profound incentive to achieve an exemplified democracy in the realm of the architectural profession.

COOPERATION AND POLICIES

The executive boards of our Association maintained a mutual understanding between the Northern and Southern Sections, which interrelationship was primarily essential in summing a smooth, rapid-functioning organization. It is hoped that the significance of unity may be impressed upon the members of our profession, especially upon those who are to become leaders in acquiring salient objectives. Under the policy of cooperation, progress is continually being made towards an improvement in the architectural field.

PROCEDURE

Basic principles were established at our last convention, many of which have been followed to successful conclusions during the past year, while others are now under consideration and



HARRY M. MICHELSEN, PRESIDENT
STATE ASSOCIATION OF CALIFORNIA
ARCHITECTS

may be further discussed at this convention. The tireless efforts of the executive boards have been fundamental factors in fulfilling these obligations with unwavering firmness, but it is realized that the action of the boards alone would have been inadequate to conduct the procedure of our accomplishments. Indispensable elements in achieving our success have been the determination and cooperation of our members, together with their readiness to be of financial assistance at all times.

COMMITTEES

When the various committees were appointed, careful consideration was given to the selection of members who would be interested in discharging the duties pertaining to the promotion of the work involved. Each committee functioned as a unit, on its own volition, in coordinating legislative, professional, industrial, financial, and other relations with outside groups and associations. Recommendations contributed by the committees, executive boards, and the past presidents have been of

immeasurable value to the president in meeting the requirements expected of him in covering the field of endeavor, and are appreciated by the entire membership.

PROFESSIONAL UNITY

It is imperative that the architects maintain a code of fair practice and a frank defense of their rights at all times. Disputes and misunderstandings, not only in our relations with each other but with our associated professions and branches of the building industry, may be advantageously settled by consultation.

One process which should not change is coordinating the important functions of business practices and ethics for the common good of the profession. Many opinions in regard to violations of accepted individual rights have created illusionary problems, which will eventually be eliminated through the combined efforts of the Association and The American Institute of Architects in promoting strength, efficiency, and integrity among the various architectural groups.

LEGISLATION

Recently the State Board of Architectural Examiners presented to the Association the "Codified Act Regulating the Practice of Architecture," which briefly may be defined as a measure to control the certified architects of this State and to penalize those who may encroach on our legal rights. The Northern and Southern executive boards have approved this proposed Act, and have recommended to the State Chamber of Commerce that it be approved and supported by them in its entirety.

When the State Legislature convenes in the early part of next year, many new issues will be submitted for consideration, some of which may be to our advantage, while others may interfere with our proposed objectives. It is the duty and obligation of every architect to take an active interest in supporting or opposing, as the case may be, any legislative matters that affect the welfare of the architectural profession or the building industry.

PUBLIC WORK

More than a year ago investigations were started concerning the commissioning of Cali-

fornia State buildings to architects in private practice. Inquiries directed to the State governmental authorities received unfavorable replies. These circumstances were also called to the attention of the Structural Engineers Association, whose findings revealed that the assignment of State work to architects and engineers in private practice seems impossible, due to the Civil Service Laws, except where exemptions are provided, and to decisions rendered by the Supreme Court of California relating to similar cases.

When our Association was authorized by resolutions adopted at the convention in Santa Barbara to continue this research, we employed John L. McNab to review the facts surrounding our status, and his opinion generally coincided with previous investigations. Evidently, the only opportunity for architects and engineers in private practice to participate on California State buildings is through the exemptions provided in the Civil Service Laws, unless these laws may be modified, or a reverse decision may be made by the Courts.

Assembly Bill No. 8, passed at the special session of the California State Legislature last January, required that the expenditure of State appropriations for the construction of County Fair buildings conforms to the Contract Act, the provisions of which automatically placed the preparation of drawings and other contract documents into the Department of Engineering. However, reference to the Contract Act was eliminated through the combined efforts of the Northern and Southern Sections of our Association, the Structural Engineers Association, and the Associated General Contractors, and it may be assumed that architects and engineers in private practice are able to participate in this work unless prohibited by other laws and regulations.

Statisticians on economical research have recognized that education is one of the nation's greatest enterprises. Well planned and soundly constructed school buildings, essential to properly meet the demands of this rapidly expanding business, are requiring greater efficiency in the services rendered by architects on these

projects. The stringent standards of design and construction stipulated by the Field Act and other governmental agencies have noticeably increased the amount of work involved in the preparation of drawings and contract documents for educational buildings.

A study of this situation has revealed an apparent need for the equalization of adequate fees; greater coordination between school districts, State departments, and other regulatory authorities; and the standardization of drawings and construction details that would be acceptable to the State Division of Architecture.

Occasionally buildings included under other classifications of public work offer such difficulties as the unauthorized competition, the reduction of fees, and the misrepresentation of facts relative to estimates and services. Our Association has been active in clarifying situations of that kind, avoiding complications that otherwise may have resulted.

Regulated competitions have been discussed of late as being satisfactory in selecting the most competent architects for public buildings; the merit system has been considered. As the construction of each type of building requires specialization in its particular classification, it would be desirable to devise a method that would determine the architect best qualified for the proposed structure.

INDUSTRIAL COORDINATION

Considerable time and effort have been extended toward establishing a closer relationship between architects and the building industry, resulting in a better understanding of numerous situations. Members of the executive boards and committees have been active in cultivating friendly contacts with industrial organizations, as experience has taught us that progress is retarded unless professional and construction groups work together when dealing with legislation, labor, and other subjects.

DRAFTSMEN'S ORGANIZATIONS

Since the draftsmen are the architects of the future, they should be acquainted with the responsibilities that will be transmitted to them

by their seniors. At our last convention, resolutions providing for a junior organization were adopted, and recommended changes to our by-laws were submitted and approved. A Draftsmen's Organization Committee was appointed, and has done gratifying work in correlating a draftsmen's society which is now a part of our Association. Through this affiliation, a thorough knowledge of our activities is made available to those who will undoubtedly succeed us in guiding the Association to higher altitudes of success.

PUBLICITY AND REPORT SERVICE

For some time the Northern Section of the State Association has been affiliated with "The Architect and Engineer," aiding in the promulgation and development of this publication and promoting a better "Report Service," and it is gratifying to know that both the magazine and the report service have become outstanding in their respective fields. I suggest that you continue to give this magazine and report service your full support, and simultaneously the architectural profession will receive greater recognition and publicity throughout the State and Nation.

FUTURE POLICIES

Since the conception of our Association, we have devoted our time to the development of legislation, ethics, business, and fees. Little consideration has been given to the quality of drawings, contract documents, and services to the client, the significance of which should be inexorably impressed upon the profession as being essential to our future success.

The executive boards have continually extended assistance to our members and district societies in solving problems that have become too difficult to be coped with individually. Results from discussions with many of our members indicate that some method should be devised whereby the various divisions of architecture should have continuous support, rather than spasmodic consideration to any one subject that may seem to be important momentarily.



RESIDENCE OF S. V. BECKWITH, JR., SAN RAFAEL, CALIFORNIA
ROLAND I. STRINGHAM, ARCHITECT; ALBERT J. EVERS, ASSOCIATE

A suburban home reminiscent of the State's history, occupying a commanding site on a heavily wooded seven-acre tract of sloping ground in the Marin hills. A view of Mt. Tamalpais and available exposures were governing factors in planning the arrangement of rooms. Skill was used by the architect to so plan the house that it would fit into the surroundings without destruction of trees which abound.

When we become stronger and better organized, it may be advisable for us to divide the Association into several groups, such as commercial, educational, residential, and miscellaneous, since there is a tendency for architects to specialize in some of these divisions to a certain extent. This change would in no way decrease the unity that has thus far been secured, but would continue to bind the Association and its allies together with greater proficiency.

Progress has been made in recent years to unify the profession, and from all indications an amalgamation of The American Institute of

Architects and the State Societies will be realized in the near future. A strong federation, representing the different groups of architecture, would have greater influence in the determination of policies that will be to the best interests of the community as well as the architects themselves. If we follow the fundamental principles set forth by industry and labor in so far as unity and financial resources are concerned, our progress should be rapid; and if properly organized, such a federation would tend to weld and strengthen the architectural profession, promote unity, and lead to achievements never before realized.

ORIGIN OF STATE ASSOCIATION OF CALIFORNIA ARCHITECTS

By JOHN J. DONOVAN, Architect

IT was the evening of February 28, 1928 that Harris C. Allen, then president of the Northern California Chapter, A.I.A., set aside a period for the Chapter to do honor to the California State Board of Architecture, as it was

then called. The writer had been a member of the State Board of Architecture since the winter of 1919-20 and at that time was its president. Prior to this and with other members of both the North and South, we had



JOHN J. DONOVAN

journeyed to Sacramento during legislative sessions to get the original Act of 1901 modified in order to enable enforcement of the law by the peace officers and courts of the State. This was attempted several times but to no avail, for as often as an amendment was offered or introduced, members of various groups interested in the building industry would inject an amendment to the original amendment which would vitiate or nullify the proposed change or the Act itself.

Harris Allen gave the Board and the profession its grand and glorious chance. Twenty-seven years of tread-mill walking had passed with no advance, so when the Chapter set out to honor the Board, the latter unintentionally reversed the order by opening the way for the Chapter to be a staunch ally and standard bearer of all the members of the profession.

The members of the Association and the

Chapters know and recall the origin of the S.A.C.A. The story is truly fascinatingly delightful. The accomplishment of the Association is really the achievement of the profession. The way the men have held together, the fellowship and friendship exemplified at the conventions and casual meetings, are cherishing thoughts which we all hold dearly.

The meeting was held with almost a full attendance of Chapter members, and as I recall, the assemblage was also thrown open to non-Chapter members who possessed certificates to practice in the State. The several members of the State Board of Architecture were called upon to give their impressions of the desirability of a tentative organization which would bend its efforts towards revamping the Act.

On presentation, the resolution and motions were carried without a dissenting voice. It was then that Mr. Allen and others acting as a committee undertook to make the step known to the members of the Southern Division State Board of Architecture. At first there was remonstrance, then when the State Board as a whole met in session at Los Angeles and as the matter was made clear to them, they fell into accord and arranged for a general meeting of all architects within and without the Chapter which was held in the banquet room of the Los Angeles Chamber of Commerce Building. There were about 250 present. Several hours were spent in presenting the matter to those present and listening to the responses. In the end a resolution was passed and carried which placed the Southern Chapter and the non-members solidly and squarely back of the movement.

From then on it was a matter of committee work, and the men who resigned themselves to the task of whipping the organization into shape deserve unstinted credit, for the work proved to be heroic and from that work emerged the S.A.C.A.



Photo by Mott

Southern California Chapter, A. I. A. Honor Award

RESIDENCE OF MR. AND MRS. THOS. F. RODGERS, NORTH HOLLYWOOD,
CALIFORNIA

ARTHUR L. HERBERGER, ARCHITECT

RELATION OF STATE ASSOCIATION TO INSTITUTE

By ROBERT H. ORR, Architect

It is assumed that out of necessity has sprung every movement of benefit to society. No one can challenge this statement with impunity concerning the formation of the State Association of California Architects. The weight of



ROBERT H. ORR

its benefits to the architects of this State cannot be measured in time and importance by any act of collective enterprise anteceding its formation.

Hailed as a benefactor to all architects of the State determined its continuance as an adjunct closely allied to the established order of architectural society so well founded by The American Institute of Architects, of long standing and distinguished service to the profession. That the founders of this order of society had in mind a structure so diversified in thought, opinion and action as to separate into two or more bodies men having the same fundamental training, underlying functions to society and aspirations to achieve, is denied by its own declaration of principle and purpose.

"To organize and unite in fellowship the architects of the United States of America, to combine their effort so as to promote the

aesthetic, scientific and practical efficiency of the profession, and to make the profession of ever-increasing service to society."

If this does not mean what it says then the architects of the nation have slumbered and slept, dreamed dreams and saw visions, to be awakened by the advance of progress and the profession outdistanced in collective bargaining so as to leave a great void in the ranks which must be circumscribed. (Collective bargaining is used advisedly as an instrument of self preservation and not exploitation for the benefit of self.)

To this the architects of the nation have set about to find a solution. To say that the key has been found in "Affiliation," "Unification" or whatever we wish to term it, and it has opened the storehouse of opportunity from which each may regale himself with the emoluments of his predecessors and ride in on flood tide may be categorically set aside as without foundation. However, out of the mass of thought that has been poured in for a truth-seeking determination, accentuated by each passing year, the latch that will unfold the best thought of man is being lifted and we shall eventually emerge out of this embryo state, architects more closely associated for the benefit of that to which we dedicate our lives.

Pointing the way, the State Associations sought the paternal care of the Institute. Its wisdom to guide was so well understood that the asking was without equivocation. Somewhere within the embrace of a society having as its purpose to combine and promote the practical efficiency of the profession, it was

thought, the force of State achievement might add something of significance. The tie that has so loosely been woven has had a salutary effect. It has made the architects of this Association more fraternal and nationally conscious. To say that the dictates of the Institute or the encroachment of the Association within the Institute has so engulfed each one as to raise the individual architect to social equality has not the least application, for collectively the architects of the whole State are but one in the present set-up.

That the State Association has only a loose tie with the Institute is not the whole story by any means. True, the Institute has no greater commitment but in the mutual work of each there runs a current of thought and action, so expressed in convention after convention, as to

leave no doubt that there is an open approach to a fuller determination of the way in which greater cooperation may be achieved.

Fully conscious of its original statement of principle, the Institute has proposed a departure in its charter provisions to bring this about and continues an appointed committee on State organization to study the whole problem for future convention consideration.

Within the province of the best minds of the Institute, supplemented by those of State Associations, there shall be worked out, through the years, an applicable solution of those broad principles which will engender not only the good will of the architects represented within the architectural bodies, but, as well, that larger mass of allied interests, the whole construction industry.



SWIMMING POOL, RESIDENCE OF A. H. BRAUNER
James H. Mitchell, Architect

LEGISLATION NEEDED TO ELIMINATE STATE BUREAUCRACY

By LESTER H. HIBBARD, Architect

THIS is an age of new ideas, new deals. Such ages have occurred in the past. Some of the ideas have been good, some of the deals have proved to be square. Thus we have progressed.

At the present moment the principles of liberty and freedom which past generations, throughout the world, fought for, seem to be dying out. The claim is made that our hard-won period of free enterprise ultimately led to conflicts of imperialism, which brought on the World War. Because of this school of thought, a clash now seems inevitable between free enterprise and government control, between individualism and collectivism. In some countries it has already taken place, in this country battle lines have been drawn.

You may wonder what this has to do with the practice of architecture. How can this affect legislation that would be vital to the interest of the architect? It can and it will, if architects are not alive to the situation and by united effort and education of the public, meet the menace which is threatening to engulf them.

Propaganda is a potent weapon by which warfare can be carried on without shedding blood. Propaganda says—uneven distribution of wealth has led to poverty and unemployment . . . that egotism, individualism and materialism are the evils of modern capitalist society . . . that the time has come when modern civilization based on individualism must be liquidated . . . that government control or collectivism is the solution.

And this is leading to what? More government in business. An increasing encroachment by government in the field of architecture. Federal, State, County, Municipal, Boards of

Education, or other political subdivisions creating their own architectural bureaus. First solely for the necessary supervisory work in connection with building programs. But few government officials are ever content to confine government to necessary governmental functions. The desire for a better job, a bigger bureau, more power, and the political emoluments and privileges which follow, soon change the picture. We see these bureaus expand and grow into full fledged architectural and engineering offices reaching out to design and control all public work. Propaganda says this is in the interest of economy, efficiency and better public structures. But the facts, if they could all be brought to light would not bear this out. And our tremendous increases in the cost of government and government structures refute such claims.

In California we are faced with an increasingly serious problem of government inroads in the field of architecture. The recently enacted Assembly Bill 744, together with the amendment of Section 4, Article 24 of the State constitution, put on the ballot under the guise of strengthening our State employment and Civil Service laws, read in effect, with minor exceptions, that no public work or employment which can be done by State employees, bureaus or departments, can be contracted to private individuals or organizations. This actually means that individual architects cannot be commissioned to furnish architectural services in connection with State work. The State Division of Architecture thus increases its scope of operations, its political power and further deprives the individual architect of possible employment.

A HILLSIDE HOUSE IN ORINDA, CALIFORNIA



RESIDENCE FOR MR. AND MRS. HERBERT P. ATKINSON,
ORINDA, CALIFORNIA

JAMES H. ANDERSON, ARCHITECT

The house occupies a steep hillside site but the needs of the owner for level spaces for outdoor living are provided by building a spacious entrance court and roof deck. The house is so placed that the branches of huge oak trees overhang the roof deck (not visible in this picture) to afford shade from the sun.

Partly because of its adaptability to a hilly site an extremely informal type of architecture was used.

Here, in the writer's opinion, is our most important legislative battle. A united front must be presented to prevent the individual architect from being submerged in a tidal wave of government control of all phases of public construction and its attendant regimentation. The seriousness of the situation can be recognized when one realizes that the advancement of the world in past ages, particularly in the fields of art, science and literature, has been due to individual effort. Art and architecture have been advanced by great artists and architects. Genius and talent are individual characteristics. They have not been nurtured by collectivism or government control. They blossom under government encouragement, languish under suppression. Freedom and liberty are a necessary atmosphere for such development.

But the architects are not alone affected. The entire construction industry, and all professional and business men whose activities could be duplicated by the State's facilities are barred from participating in public work. Herein lies our strength, our hope of changing the present order, of getting government back into governmental channels and out of the fields of business. By cooperation and uniting our efforts with others affected, private enterprise and individual effort can be protected and fostered, and permitted to participate in public work.

Such a program is under way now, fostered by the California Construction Congress of our State Chamber of Commerce. A special committee is working on appropriate recommendations as to the feasibility of an amendment to the sections of the State Constitution covering employment and Civil Service, and possible amendments to the State Contract Act, A. B. 744, to permit employment of architects and engineers in private practice on public construction projects. This is vitally important legislation which the State Association of California Architects should aggressively support. In the opinion of many architects it transcends in importance an attempt to strengthen the Act to Regulate the Practice of Architecture. An added indication of the trend is the Federal

Government's fostering of Small House Bureaus to furnish stock plans for small houses financed by Federal Savings and Loan Associations and the F. H. A. A continuance of government expansion may soon leave little practice to regulate.

The other major legislative interest of the architect, the Act to Regulate the Practice of Architecture, has been codified by the State Code Commission in a satisfactory manner and will be presented to the coming session of the Legislature for adoption. This involves no change in the terms of the Act. It simply codifies it with all other vocational and professional acts so that all such acts will be uniform in make-up.

This brings us to a momentous decision. Shall the architects take advantage of the fact that their present act, codified, will be before the coming session of the Legislature and present a few simple and necessary amendments to strengthen the act and make it enforceable by the State Board of Architectural Examiners?

The alternate course would be to present to the Legislature a new revised act, codified in form, completely amending the present act. Such a revised act has been prepared by the State Board of Architectural Examiners and is ready for presentation to the 1938 convention of the State Association of California Architects.

The revised act, in theory, is purely a professional practice act, as endorsed in principle, by past conventions. It circumscribes the right of anyone to use the title "Architect." It sets up no restrictions which will create business for the architect. It has many admirable features. Likewise some features that might be of grave consequences to the profession. Every architect in the State should have all the facts and probable consequences of either course placed before him and should register his opinion or vote for the guidance of those whose duty it will be to determine a legislative policy and carry it out.

Such a decision should take into consideration the question of whether an act that has all the evidence of being new legislation would have a reasonable chance of enactment. And

THE LURE OF OUTDOOR LIVING



Photo by Waters & Hainlin

HOUSE FOR ORTON LUCAS, ORINDA, CALIFORNIA
FREDERICK L. CONFER, ARCHITECT

The basic requirements of the owner for this house were a request for privacy and facilities for out-door living. The lot is situated in a prominent gore, surrounded on three sides by a main thoroughfare. As the lot is very much higher on one side than the other, the problem was to place the house so as to achieve the maximum amount of privacy from the pedestrian. This was accomplished by placing the body of the house so as to form a screen from the lower road. Some fine old oak trees give privacy from the upper road.

Two bedrooms only being required upstairs, permitted the use of the charming simple plan with balcony off each bedroom. A rear terrace lends itself to the needs of the owner for barbeques, buffet suppers, etc., during summer months.

if passed, could it be steered through the legislature without objectionable amendments which would nullify its purpose or possibly result in a practical repeal of our present act? It should be kept in mind that our present act has been on the statutes nearly forty years, has been successfully amended in the past, and probably can be strengthened in the future by a few simple amendments.

In view of the fact that the construction industry as a whole may undertake to present to

the people a referendum upon an amendment to the State Constitution and may also attempt legislative amendment of the Contract Act or A.B. 744, architects should duly consider their chances of success with two major legislative undertakings to sponsor with possible support from the construction industry centered elsewhere. Whatever the decision, it should be one that all architects can support, our friends of the construction industry can endorse and, by united effort, can be successfully carried out.

Collectively we can insure our individualism.

MORE BUSINESS FOR ARCHITECTS

By CHESTER H. MILLER, A.I.A.

WEBSTER defines Business as "a state of being busy; that which engages one's attention or labor as a principal serious employment." (Most of us are familiar with the "labor" part of this definition.)

The assigned subject, "More Business For Architects," fails to state—Who's business—our own, or other people's. I am inclined to believe that as architects we give too little attention to Other People's Business.

How many architects of your acquaintance give any of their thought and time to the business of their own organizations—the Institute or State Association? How many of us take any interest or give time to the business of running the affairs of our own community? How many architects do you know in your community who are prominently identified with civic affairs? In our troubled labor relations, how many of us are working with civic groups in an attempt to solve this all-important

problem? You should know the answers.

The building industry is a complex, unorganized, disjointed affair. How many architects make it their business to join with other allied groups in the building industry in an attempt to be helpful in working out our mutual problems?

The Institute and the State Association have made it their business to interest themselves, as organizations, in More Business For Architects and the average architect has been quite content to let it go at that. (There are always the handful of old faithfuls who do all of these things, but far too few.)

As a profession, we have earned a reputation of having little or no contact with civic affairs or a capacity of practical contact with business affairs; preferring, it may be, to be thought of as professional and not business men. Times have changed.

A HOUSE THAT HAS WON NATIONAL RECOGNITION



RESIDENCE FOR MR. AND MRS. ROBERT B. MITCHELL, FIEDMONT,
CALIFORNIA

MILLER AND WARNECKE, ARCHITECTS

This house, illustrated before in this magazine, has been nicely situated and designed to fit into the landscape. The architectural lines were kept low and informal; the sunken garden entrance court lends privacy to the front garden. As many rooms as possible were opened onto terraces and balconies facing south. Both bedrooms have cross ventilation, sun and a balcony.

UNIFICATION MOST DESIRABLE

By ALBERT J. EVERS, F.A.I.A.

Director Sierra Nevada District, A.I.A.

THERE has grown within the architectural profession during the past ten years a widespread realization of the need for an all-inclusive organization—one which will represent the entire profession in point of numbers.



ALBERT J. EVERS

The American Institute of Architects has for many years been the only body capable of representing the profession, and it has done so with honor and credit. Unfortunately, there are many architects who, for one reason or another, do not become members of the Institute. In our own State, some ten or eleven years ago, the need for a complete organization resulted in the founding of the State Association of California Architects. The Association, differing from so-called State Societies formed in the past, was begun under the auspices and sponsorship of the Chapters of the Institute, and by close harmony and interlocking committees the all-inclusive State Association became a strong and friendly ally of the local Institute Chapters. In order to prevent duplication of effort and to divide organization work it was mutually agreed that the Institute Chapters would primarily care for the ethical, educational and cultural matters, while the Association should exert its primary efforts on legislation, office practice and

public information. There has been a marked degree of success in this plan of related and cooperative organizations. The Institute, by virtue of its national standing and high ideals, has been taking a natural leadership.

The success attained has led to similar organizations in other states and a further step forward in the provision that all inclusive State Societies may become members (as organizations) of the Institute, and have a voice in Institute affairs. Such membership requires a commitment from the State Society that it will support and do its utmost to uphold in every way the ethics and principles of the Institute. The individual member of the State Society does not thus acquire A.I.A. membership, but through his organization has some voice in national affairs.

At the New Orleans Convention the relationship between the Institute and State Societies was made still stronger, in response to a nationwide demand for unification of the profession. The State Societies were granted a directorship and will now have a direct representative on the board of directors of the Institute. It was further decided by the convention to pursue a vigorous program for organizing State Societies. From all parts of the nation, those who would seem most qualified to judge have felt that the existence of two national architectural groups, separate, would lead to confusion and disharmony. On the other hand, an affiliation of all-inclusive State Societies, through the leadership and organization of the Institute, provides a means for national solidarity and paves the way toward great accomplishment for our profession.

A CABANA AND CLUB HOUSE BY THE SEA



BILTMORE BEACH AND CABANA CLUB, SANTA BARBARA, CALIFORNIA
GARDNER A. DAILEY, ARCHITECT

The building occupies a triangular area of less than three acres, surrounded by ocean, airport and highway. It was required to place an Olympic pool, 60x160-foot bath house, cabana and club building for 500 members and guests, at the same time to provide complete privacy and shelter with maximum of sun and air.

To function at night as well as by day, the cool water is heated by submerged steam pipes. The tower was constructed to act as a beacon for a future yacht harbor.

Wood has been used throughout the interior and exterior, suggesting lightness and fitness to the location by the sea. Pool decks are of gray cement, court and interior floors are of polished black terrazzo tile, other floors are natural oak, waxed.

WHERE LIFE IS JOYFUL AND CARES ARE FEW



Photo by Starkecont

BEACH HOUSE IN NORTHERN CALIFORNIA
WILLIAM WILSON WURSTER, ARCHITECT

Here the architect has designed for his client a livable abode yet just the reverse side of the coin from daily living . . . for a family with two boys, a servant and one or two guests during the summer, planned to accommodate as many as eight over a week-end.

Of importance were the elimination of housework and the creation of a house in which wet bathing suits, dogs and parties could be at home without any "don'ts," . . . from the practical standpoint the bathers can shower by entering from an outside door; the servants room may be used as a guest room or a dressing room for bathers. Entrance is gained to the second floor without the living room becoming a traffic-way.

MID GREEN LAWNS AND SPREADING OAKS



Photo by Crandall

RESIDENCE OF MR. AND MRS. J. C. WINTERBURN, MENLO PARK, CALIFORNIA
BIRGE M. CLARK AND DAVID B. CLARK, ARCHITECTS

The low horizontal feeling of this house is emphasized by the use of broad eaves. Gardening as such is reduced to a minimum, the spaces being filled by lawns, while lovely spreading oak trees complete the decorative note.

The patio, not shown here for want of space, faces to the southeast and is spread to the fullest extent by distributing the entrance hall, living room, dining room and breakfast room along one side. Den and bedrooms form the opposite side. Wide brick walks frame the patio grass plot.

IS ARCHITECT LOSING HIS INDEPENDENCE?

Richard Neutra Says Signs Point That Way

RICHARD Neutra, of California, recently spoke before the Association of Federal Architects in Washington, D.C., giving a blend of architectural history, architectural prophecy, and present-day philosophy.

He traced the history of the architectural profession, building up from a very exact knowledge of the past an absorbing and illuminating picture of the trends of the present day.

He brought forth the fact, to which few architects have given much consideration, that architecture, as an independent profession, did not exist prior to the Renaissance.

Until that time, it was a governmental function. In fact in early Greek days architects and architectural draftsmen were actually slaves, working under the rule of the emperor or governor who had control of the construction funds.

There was then no differentiation between architect and contractor. What the architect designed he held responsibility for until it was placed in the building and had received its final finish.

Therefore, full-size details were apt to be worked out at the job in the materials. As a matter of fact, as Mr. Neutra pointed out, the ornament and detail were traditional, in somewhat the same manner as the later ritual of the church became fixed and traditional.

As such its appeal was sentimental as well as aesthetic. By inheritance the Greek and later the Roman loved the column and the classic forms generally.

In addition the Greek was naturally a sculptor and the perfection of the detail was due not only to the inspiration and direction of the architect but as well to the individual skill of the carver.

Mr. Neutra called attention to the extreme simplicity of the early architectural problem, observing that the specifications need only have contained the one word "marble."

When the Renaissance came, the problems of plan and design became more complicated and the architect by virtue thereof emerged from the multitude to appear as a specialist. The matter of charges and fees was not crystallized and the architect, like others of his artistic world, had to be supported by the bounty of a rich patron.

That was the birth of the architect, as a member of an independent profession. It was historic fact. Mr. Neutra went on to turn it into prophecy. He said that the architect was now heading back into the earlier condition where he would again be a part of the civic set-up and work through Federal or State organization channels rather than as an independent agency.

In the totalitarian states he showed that this had already come about. There, he said, the title architect was a "formality."

It was the dust-thou-art-to-dust-returnist theory. Whether it is a prophecy that will be fulfilled is uncertain. Mr. Neutra's interest was in the fact that such was the tendency.

Its fulfillment naturally must depend upon the future course of American governmental

development. If America should follow the world and revert to the ancient Greek benevolent (or malevolent) despotism, architecture will resume its original submerged position, as in the ancient days.

Should America retain its individualism, architects will of course retain theirs.

Mr. Neutra pointed out, however, the increased understanding of and the increased necessity for Government architectural units. The Government, due to the increased complication and interlocking of modern conditions, has been compelled more and more to assume control where in simpler times no control was necessary. That control carries with it the necessity for construction and the necessity for control of its construction design by the Government.

The free hand of the architect of the early 1900's will never again be realized. Public construction problems require control, which points to a segregation of a certain portion of the profession under Federal or State financial support.

Naturally unified control in the past tended toward more stabilized architectural style. The coming of the private architect in the Renaissance period tended to diversify the styles and make individualistic the interpretation of the styles.

Mr. Neutra was interested in the manner in which the architectural styles jumped the Atlantic to develop in the American colonies.

He spoke particularly of Mexico and referred to "Colonial" meaning Mexican Colonial.

The history of Mexican Colonial was gener-

ally the history of other Colonial architecture. Naturally the building activity of the new colonies surpassed that in the mother countries, because of the need and because the mother country's money was needed for wars.

This paradox then took place, in that the development of the styles went on in the colonies, whereas no development went on in the mother countries.

Colonial therefore came to mean not a subsidiary architecture, but an original style, more virile than the European. In fact when building activity reoccurred in the mother country, the tendency was to turn to the colonies to find out to what point the style had progressed.

In other words style development occurs where building activity occurs. As a corollary to that theme, Mr. Neutra called attention to the Mission style, which is a phase of the Mexican Colonial, in Southern California. There extreme building activity in that style carried it to a point of perfection and finesse not before achieved.

As a result, a Mexican gentleman desiring to build a hacienda in the Mexican style now comes to Los Angeles to look about and find out how to do it.

The talk pointed to the inevitability of more and more centralized control, as time went on, of construction. And, since style develops where construction is centralized, it pointed to a more uniform architecture, in the future, due to this more uniform control. This would be merely following Greek architecture which was uniform largely because its control was uniform.

CALIFORNIA STATE BOARD OF ARCHITECTURAL EXAMINERS

By A. M. EDELMAN, First President of State Association and Dean of Architects

IN the early Nineties of the last Century, inroads in the practice of Architecture by persons unqualified, using the title "Architect and Builder," and disregarding safety and esthetics to such extent, the California Chap-

ters of The American Institute of Architects, impressed with the seriousness of the situation, began consideration of a bill to regulate the practice of architecture, similar to the Act then in force in Illinois,

pointees of the Governor, were present and organized the Board with

Octavius Morgan, Los Angeles, President;
Seth Babson, San Francisco, Vice-President;
Merritt J. Reid, San Francisco, Secretary-Treasurer;
Fred L. Roehrig, Los Angeles, Assistant Secretary.

Members:

William Curlett, San Francisco;
Lionel Deane, San Francisco;
H. F. Schultze, San Francisco;
Sumner P. Hunt, Los Angeles;
John P. Krempel, Los Angeles;
Will S. Hebbard, San Diego.

At that meeting, "Rules and Regulations" were adopted and at the next meeting, July 30, the Board began consideration of applicants for license as architects. In the Southern District, twenty-five architects were approved at that meeting. During the first two years 238 architects in the Northern and 96 in the Southern District were licensed, with two from out of State.

The first amendment to the Act was approved 1903, creating an annual license fee which had been omitted in the original bill. In 1929 and 1931 other amendments were passed, propoorted to strengthen the Act, due to continued violations by unqualified and unlicensed persons.

During the early years of the Act, several changes were made in the Board membership of the Northern District, both due to death and resignation but the Southern Board personnel remained intact until 1919 when the entire Board, with exception of the secretary of the



A. M. EDELMAN

and through correspondence with Illinois Board members, sufficient data was obtained to have the first draft considered at a meeting in December 1898. It was not until 1901, however, that the bill was introduced in the Legislature, and passed and approved by Governor George C. Pardee on March 31. The intent of the Bill was for the protection of life, health and property, by permitting only properly qualified and licensed persons to practice architecture.

The first meeting was held in San Francisco June 21, 1901, at which all ten members, ap-

Northern Board, Sylvain Schnaittacher, was replaced, and the appointees by Governor Wm. D. Stephens, were as follows:

John Parkinson, Los Angeles, President;
Clarence R. Ward, San Francisco, Vice-President;
Sylvain Schnaittacher, San Francisco, Secretary-Treasurer;

A. M. Edelman, Los Angeles, Assistant Secretary-Treasurer;

William J. Dodd, Los Angeles;

Myron Hunt, Los Angeles;

William H. Wheeler, San Diego;

James R. Miller, San Francisco;

John P. Donovan, Oakland;

Edward Glass, Fresno.

Since then material changes in personnel have been made, with one exception, A. M. Edelman, the present secretary.

Since 1931, several unsuccessful attempts were made by the Board and supported by the State Association of California Architects to amend a few sections of the present Act, particularly Section Five, which section unfortunately proved contrary to the desired intent of the Act, brought no assistance to the Board to prevent non-architects practicing architecture.

The present Act has withstood favorably several attacks before the highest State tribunals. It is therefore my suggestion that a few essential amendments recommended by the profession and endorsed without prejudice for better control of unprofessional conduct, and the encroachment upon the profession by unqualified persons should be introduced in the next Legislature.

CO-ORDINATION

By HARRIS C. ALLEN, F.A.I.A.

PRESIDENT Harry Michelsen has asked me to contribute to this Decennial Symposium a story on the Association's "Co-ordination of Arts and Architecture." This is not a difficult task, for long ago, in the mutual division of



HARRIS C. ALLEN

activities, the

three E's were assigned to the Association — Readin' (codes and contracts), Ritin' (specifications), and 'Rithmetic (costs and certificates, expenses and extras).

And yet there has been co-ordination with Arts. The arts of Music and Miming, of Fel-

lowship and Friendship, have been made a prime objective in our meetings for consultation and agreement. The arts of consideration and, perhaps, compromise, have been cultivated in the gradual development of our better understandings with engineers, contractors, producers. The arts of the palate have not been neglected, have played their parts in these ten years of getting acquainted and building up a better organization of the disorganized building industry.

All of the other presidents, past and present, will join with me, I am sure, in the belief that "Co-ordination" is the essential, indispensable feature and factor in the measure of success attained by our Association—or by any group activity, for that matter.

It is especially important with the relations of such individualists as architects; and our profession today is in a firmer and more united position than ever before, thanks largely to the State Association's ten years of organized effort, experiments and endurance.

SPECIFICATIONS FOR STRUCTURAL CONCRETE

By JOSEPH A. KITTS,

Member, Structural Engineers Association of Northern California

THE following specifications coordinate and are consistent with all authoritative standards and specifications for structural concrete. Technological conditions, comparable with those for the manufacture of aggregates, cements, and reinforcing steel, are provided for as measures essential to engineering economy and reliability. Reliable concretes, and economical engineering designs therewith, are recognized as dependent upon coordination of the work of the engineer skilled in concrete manufacture and that of the engineer skilled in structural design. The specifications are presented in as concise form as permitted by the many particulars involved.

Admixtures:

Materials used as admixtures shall have established merit in accomplishing any of the following enumerated effects, when desirable, without deleterious effects otherwise: (1) Prevention of shrinkage in setting; (2) Improvement of plasticity, workability, flowability, and cohesion of the fresh concrete; (3) Waterproofing; frostproofing; (4) Curing, or proofing against various chemical reactions; (5) Acceleration of hardening, setting, or strength; (6) Deceleration of setting time; (7) Densifying, or increasing weight; (8) Increasing yield, or reducing weight; (9) Bonding new to old concrete; (10) Coloring; (11) Hardening.

Admixtures shall be approved in writing by the (Architect) (Engineer), and the correct proportions shall be determined by the concrete technologists. Item (1) shall be required for all structural concrete.

Aggregates:

Aggregates shall be supplied in the several commercial sizes, including fine and coarse sands and fine, medium and coarse gravel or crushed rock, and shall uniformly conform to the approved samples submitted.

The maximum size of the aggregate (as determined by the square hole through which 85 to 95 per cent by weight can be passed) shall be as large as practicable to use under the given conditions, but shall not be larger than one-fifth the prevailing narrowest dimensions between forms, nor larger than one-third the depth of slab, three-fourths the clear spacing between reinforcing bars, three-fourths the space through which it must pass, nor larger than may be permitted by the conditions otherwise. These maximum size limits may be increased slightly if compacting is done by mechanical vibration.

Storage, Proportioning and Mixing Plant:

The contractor shall provide self-cleaning aggregate bunkers and a concrete proportioning and mixing plant acceptable to the (Architect) (Engineer); and such plant shall include weighing batchers for aggregates and cement, and weighing batchers or meters for measuring water. The plant shall also include essential stationary and transit batch mixers of approved modern type.

Concrete Quality and Production Control:

Structural concrete shall have a predetermined standard strength in compression of 3,000 pounds per square inch at 28-days age, as determined by the A.S.T.M. standard compression tests (C-31 and C-39), with tolerances in accordance with Section 327-SA, Standard Specifications for Concrete, Joint Committee Report of January, 1937.

The quality of the concrete shall be predetermined and maintained by a firm of Concrete Technologists, acting as representatives of the (Architect) (Engineer) (Owner).

Pretesting of materials and concrete, and control of the proportions of ingredients in the concrete mixtures shall be maintained by the Concrete Technologist; the workmanship in mixing, transporting, placing and curing shall be subject to his direction; and the Contractor shall fully cooperate with him to produce concrete of the specified quality and workmanship.

The Concrete Technologists shall provide an average of one man-hour of efficient laboratory and inspection control for each 15 cubic yards of concrete required. Tests and inspection of materials and concrete shall be constantly maintained at the plant and/or on the job, and the absolute-volume composition of mixtures shall be sustained by varying the measured proportions as the individual aggregates vary in moisture content, absorption, bulking, grading fineness modulus, density, specific gravity and other physical characteristics.

The absolute-volume composition of a unit volume of concrete shall be: (a) the absolute volumes of rock particles of definitely graded sizes, (b) the absolute volume of cement, (c) the absolute volume of admixture, and (d) the volume of mixing water, correcting for free water in the aggregates, and these shall be determined by the Concrete Technologists for the particular conditions and purposes. Concrete mixtures shall be further designated by the maximum size of

the aggregate, the fineness modulus and grading of the mixed aggregate, the type and source of aggregate, and the consistency of the concrete as measured by the standard slump test.

The quality of the concrete shall be or shall have been predetermined by the Concrete Technologists by predetermination for the job conditions of the proper mathematical constants in the following:

- (A) The Abrams water-cement ratio-strength law;
- (B) The Kits cement content-strength laws;
- (C) The Kitts optimum fineness modulus law;
- (D) The Fuller, Talbot, Bolomey, or Kitts grading of solids;
- (E) The Feret absolute-volume composition law; and
- (F) The Kitts absolute-volume yield law.

The "yield of concrete" shall be maintained by the Concrete Technologist within one-half of one per cent plus or minus, and correct within one-tenth of one per cent on an average, but not including loss by leakage, wastage or otherwise. Twenty-seven cubic feet total absolute volume of ingredients (aggregate, cement, mixing water and admixture), with such correction for absorbed water, cement soluble and entrapped gas as the Concrete Technologist may determine, shall be accounted as one cubic yard of concrete; and the total weight of ingredients shall be checked against the average weight of the fresh concrete filling a standard container of known volume.

The Concrete Technologists shall maintain chronological records of tests of materials, special tests, mixture proportions, and daily production, and shall make certification of same as the work progresses.

Predetermined Concrete Mixtures:

Under the foregoing specifications, and employing local cement and natural sand and gravel aggregates*, the maximum sizes of aggregate, cement contents, and slumps, shall be as given in the following table, depending upon mixing time and whether mechanically vibrated:

3000-LB. CONCRETE AT 28 DAYS AGE*

Parts and sections of construction	Method	Maximum size of aggregate in inches	Standard slump in inches	Mixing Time	
				1½ min. W/C= .874	6 min. W/C= .59
				Lbs. cement per cubic yard of concrete	
Foundations, large footings, columns over 25", walls 12" or over	H	2	7	600	486
	M	2½	4½	462	380
Med. footings, columns over 20", and 10" to 12" walls and beams	H	1½	7	629	513
	M	2	5	503	416
Small footings, 8" to 10" walls & beams, columns over 12" and slabs over 5"	H	1¼	7½	696	566
	M	1½	5½	551	457

*This table is for various normal standard Portland cements produced in Northern California, and various natural sand and gravel aggregates regularly stocked in San Francisco.

Small footings, 5" to 8" walls & beams 4" to 6" slabs, and columns over 12"	H	1	7½	725	594
	M	1¼	5½	572	476
4" to 6" walls & beams, 3" to 4" slabs, and columns over 10"	H	¾	8	831	665
	M	1	6	620	517
3" to 4" walls, 4" beams, 1½" to 3" slabs, & columns over 3"	H	½	8½	932	782
	M	¾	6½	688	576

H—Hand vibration, M—Mechanical vibration.

Change of Cement, Strength and Slump:

The Contractor may use "high-early" strength Portland cement in lieu of normal Portland cement, at his own extra expense; attainment of the specified strength may, accordingly, be advanced from 28 days to 7 days, and forms may be removed in (1 to 3) days, as approved by the Engineer.

The Contractor may use additional cement at his own expense in order to accelerate strength, increase slump, or to accomplish any other desirable purpose sanctioned by the (Architect) (Engineer), the mix ingredients to be adjusted by the Concrete Technologist.

Increase of cement contents, required by the Owner or his agents, shall be required in writing, shall be properly accounted for by the Contractor, and the increased amount of cement shall be an extra at the expense of the Owner at (\$) per barrel (376 pounds).

Water-Cement Ratio:

The water-cement ratio, W/C, shall be the cubic feet of total mixing water per sack (94 lbs.) of cement. The total mixing water shall be the algebraic sum of the added water, plus the water in the aggregate, minus the water absorbed by the total absolute volume of aggregate particles.

Transporting Concrete:

Concrete shall be handled from the batcher and/or mixer to the place of final deposit as rapidly as practicable by methods and facilities which will prevent stiffening, initial set, and segregation or loss of ingredients. Truck mixers shall be used for central plant concrete. Chutes shall be of metal or metal lined; different portions of same shall have approximately the same slope throughout; the slope of chutes shall not be less than 1 vertical on 2½ horizontal (40% grade); and the discharge end shall be provided with a baffle plate, splash board, spout, or other arrangement which will prevent segregation and will drop the concrete vertically into place. Equipment and methods proposed for pneumatic placing, or for pumping, shall be approved by the (Architect) (Engineer).

Placing of Concrete and Workmanship:

Concrete shall not be placed until the forms and reinforcement have been inspected by the architect or engineer responsible for the design or authorized

representative, nor until all equipment for batching, mixing, transporting and placing have been properly cleaned, all debris, ice, and water puddles removed from the places to be occupied by the concrete, the forms suitably cleaned and wetted or oiled, and the reinforcement thoroughly cleaned of injurious coatings.

Competent manual labor of placing shall be not less than one man-hour for each (2) cubic yards per hour. Labor of placing shall include rodding, spading, tamping, hammering, vibrating, treading, and such other operations excepting finishing as are necessary to compact and mould the concrete into place. A mechanical vibrator and one or more operators may place from (2) to (20) cubic yards of concrete per hour as shall be determined by the Concrete Technologist for the particular conditions.

Concrete shall be systematically deposited in shallow layers and at such rate as to maintain, until the completion of the unit, a plastic surface approximately horizontal throughout. It shall be deposited vertically and separation prevented by the use of tremies, splash boards, or other suitable means; plastic concrete shall be continuously deposited on plastic concrete after starting the pour, and columnar sections shall be poured slowly to allow for shrinkage and continuously to prevent pour joints. In no case shall the concrete be dropped freely through the air for a height greater than (12) feet.

Concrete during and immediately after depositing shall be thoroughly compacted by means of suitable tools such as tampers, rods, forks, spades, hammers, internal and/or external vibrators. Accumulations of water on the surface of the concrete, due to water-gain, bleeding, or other causes during placement and compacting, shall be removed by drawing off, displacement or bailing, and under no circumstances may concrete be placed in such water accumulations.

In stopping concrete for any reason, make the joints at such places as the (Architect) (Engineer) shall direct. Where a horizontal joint is to be made, an approved stopping strip shall be provided; any excess water shall be removed from the surface after the concrete is placed, and the joint shall be compacted, troweled and finished in a workmanlike manner.

In resuming placing, clean old surface, remove damaged concrete, tighten forms, then grout with a 3 to 6 inch layer of special mix which shall consist of the finer ingredients of the particular mix for the given location.

ARCHITECTS GET FEDERAL WORK

The following architects have been selected to work on a \$2,500,000 Federal Housing project for West Oakland, the improvements to include a group of buildings planned in connection with U. S. slum clearance: Miller & Warnecke and Hugh C. White, Oakland; John J. Donovan, Berkeley; F. H. Reimers and H. A. Minton San Francisco.

ARCHITECTS MEET ENGINEERS IN JOINT BANQUET

A RCHITECTS, engineers and general contractors staged a highly successful get-together banquet at the Engineers Club in San Francisco the evening of September 16. The dinner was the third annual of its type.

Represented by large delegations, in addition to structural engineers and architects, were both the Northern California and Central California Chapters of the Associated General Contractors.

Giving the dinner a state-wide aspect was the fact that one of the two principal addresses of the evening was delivered by Lynn Atkinson, Southern California contractor.

Mr. Atkinson outlined the "Overhead and Express Highway" proposal which recently has been attracting wide attention and for which he has been acting as an ex-officio ambassador-at large. He made particular reference to possible application of the plan in San Francisco and Los Angeles.

A discussion of the "Development and Design of the Funston Avenue Approach to the Golden Gate Bridge," prepared by Colonel John H. Skeggs, District Engineer for the State Division of Highways, was read and illustrated by Mr. Harding of the division staff.

Guests of honor at the dinner meeting included J. H. Franklin, Chief Engineer for the American Institute of Steel Construction of New York; C. L. Warwick, Secretary of the American Society for Testing Materials of Philadelphia; C. H. Purcell, California State Highway Engineer and executive officer for the California Commission for the Golden Gate International Exposition; A. D. Wilder, Director of the San Francisco Department of Public Works; George B. McDougall, State Architect; W. P. Day, Vice-President and Director of Works for the 1939 Exposition; Floyd O. Booe, Secretary-Manager of Northern California Chapter, Associated General Contractors; and Wm. E. Hague, Secretary-Manager of the Central California Chapter, Associated General Contractors.

Presiding as chairmen and toastmasters were three officials of the architects' and engineers' groups.

They were: Warren C. Perry, President of the Northern California Chapter, American Institute of Architects; Harold B. Hammill, President of the Structural Engineers' Association of Northern California; and Harry M. Michelsen, President of the State Association of California Architects.

Civil Engineers Active

San Francisco Section, American Society of Civil Engineers, held an interesting meeting in Wheeler Hall, University of California, Berkeley, October 6. The principal speaker was Julian Hinds, Assistant Chief Engineer of the Colorado River Aqueduct project, whose subject was "Bringing Water Across the Desert."



COOPERATIVE GAS INDUSTRY BUILDING AT TREASURE ISLAND

GAS EXHIBIT AT GOLDEN GATE EXPOSITION

Animation, color and lively interest will feature the Pacific Coast Gas Association cooperative exhibit at the Golden Gate International Exposition. Utilities and

On October 11th at the San Francisco Engineers' Club, the San Francisco Section held a joint meeting with the San Francisco Engineering Council. After dinner there was a demonstration lecture at the P. G. & E. Auditorium on "Sounds, Ears, Noises and Acoustical Measurements and Their Relation to Machinery Quiet-ing." The speaker was Dr. Ernest J. Abbott, President of Physicists Research Company.

The Section will hold its annual party this year at Treasure Island with an exposition preview and other features. The date is October 22. A. R. Tudor is chairman of the entertainment committee.

Engineers to Meet at El Encanto

The annual convention and outing of the Northern and Southern Sections of the Structural Engineers of California will be held this year at the beautiful El Encanto Hotel, Santa Barbara. Last year's convention was held in Pacific Grove. The Southern Section will do the entertaining this year so a Southern California city was selected for the meeting.

El Encanto Hotel is said to be greatly improved in accommodations and cuisine since it was taken over by Frank McCoy, owner of Santa Maria Inn where the engineers met three years ago. A splendid time is promised those who attend. The dates: October 28-29th.

manufacturers from Hawaii to Texas are cooperating in a novel display at which visitors can see, feel and hear the latest automatic gas appliances for cooking, house heating, refrigeration and water heating.

In the Golden Gate end of the Homes and Gardens Building, a floor area of some 10,000 square feet is being transformed into a beautiful Spanish court which will enclose the gas industry exhibit. Architectural variety has been accomplished to an unusual extent.

There is a public concourse of about 3,672 sq. ft., with a seating capacity of 164. The main point of interest here is a large window panel of a Spanish house. This window actually becomes a proscenium to a revolving stage on which are shown modern gas appliances within a series of six beautiful kitchens, and a model utility room, styled to the step-saving, convenient home of today.

These stage features are presented individually at four-minute intervals on a 35 ft. revolving steel platform which sets up each stage automatically; chimes announce the curtain, and the show is on.

On these stages the appliances do their own acting, showing off their various features and accompanied by spoken description. There appear also projected natural color photographs illustrating the various cooking operations as the features are presented by the range in action. When the appliance has completed its presentation, it quietly folds up, the curtain closes, and the next stage is set up and made ready.

(Please turn to Col. 2, Page 58)

With the Architects

NEW SCHOOLS AND ADDITIONS

Architects on the Pacific Coast who specialize in school designs are especially busy with work at this time, due mainly to generous allotments of PWA money. The list includes:

A \$50,000 addition to the Hayward High School, Henry C. Smith of San Francisco, architect.

Classroom addition to the Brentwood-Deer Valley School, Frederick H. Reimers, San Francisco, architect.

Cafeteria and domestic science wing to Taft Union High School, Franklin & Kump, architects, Fresno.

Auditorium and class room addition to Lafayette Grammar School, E. Keith Narbitt, architect, Richmond.

Science room addition to Gonzales Union High School, Chas. E. Butner, architect, Salinas.

Bonds have been voted for a group of new high school buildings at Carmel to cost \$300,000. No architect has been named as yet.

A \$40,000 addition to the San Andreas Grammar School, Geo. C. Sellon, architect, Sacramento.

Auditorium and gymnasium at Gustine, Merced County to cost \$65,000, Franklin & Kump, architects, Fresno.

Group of grammar school buildings at Exeter, Tulare County, H. L. Gogerty, Los Angeles, architect.

Bonds for \$600,000 have been voted for new Junior High School buildings at Santa Rosa, Harold H. Weeks, architect, San Francisco.

A 12-room class room building at the Mastick School, Alameda, from plans by Kent & Gass, architects, San Francisco.

Alterations and additions to the Colton Grammar School, Monterey, Robert Stanton, Del Monte, architect.

Group of High School buildings at Corcoran, Kings County to cost \$200,000, H. L. Gogerty, architect, Los Angeles.

Completion of High School shop building, Berkeley, \$165,000, Corlett & Gutterson, Oakland, architects.

Eleven class room addition to Burbank School, Santa Rosa, Wm. Herbert, architect, Santa Rosa.

Additions aggregating in value \$500,000 to Vallejo High School, John J. Donovan, architect, Berkeley. Also additions to Niles High School, \$150,000.

THEATER AND STORES

A. A. Cantin of San Francisco has completed plans for a one-story reinforced concrete theater and store

building to be built at Brown Avenue and Hopkins Street, Oakland, for J. Catucci, 1212 18th Avenue, Oakland. The estimated cost is \$50,000.

TWO MILLION FOR S. F. SCHOOLS

PWA grants have been approved and bonds voted for the following new school work in San Francisco:

Haight School, Outer Mission District	\$ 900,000
First unit, Abraham Lincoln High School	750,000
Junior College buildings	1,366,032
Auditorium, Geo. Washington High School	325,000
Second unit, Samuel Gompers School	190,000
Kindergartens at Francis Scott Key, Visitation and Glen Park Schools	70,000
Geo. Washington High School athletic unit	438,555
Horace Mann gymnasium and cafeteria	151,291
Portola Junior High School auditorium	68,348
Franklin School addition	47,562
Francis Scott Key addition	61,734
Lawton auditorium and kindergarten	67,930

PERSONALS

P. P. Lewis, formerly located at 1063 Westwood Boulevard, West Los Angeles, announces the removal of his offices to Room 208, Chapman Building, 10929 Weyburn Avenue, West Los Angeles.

Sumner M. Spaulding, architect, and C. Gordon Deswarte, structural engineer, formerly located at 9441 Wilshire Boulevard, Beverly Hills, announce the removal of their offices to 3305 Wilshire Boulevard, Los Angeles.

C. H. Russell, architect, has moved from 1340 S. Berendo Street, to 1110 S. New Hampshire Avenue, Los Angeles.

A. C. Zimmerman, architect, has moved from 709 H. W. Helman Building, to suite 611 Architects' Building, Los Angeles.

Ralph C. Flewelling, architect, has moved from 614 Architects' Building, Los Angeles, to suite 611 in the same building.

Richard J. Neutra of Los Angeles, has received notice of award of a bronze medal for his designs of the Gertrude Kun residence at Altadena, and a school building at Bell exhibited at the Paris International Exhibition, Paris, in 1937.

Palmer Sabin has moved his office from 170 E California Street, Pasadena to 3305 Wilshire Boulevard, Los Angeles.

MORE PERSONALS

George W. Groves, Seattle, has moved his office to Room 309, Textile Tower, from Room 1402 in the same building.

Donald N. McDonald, Seattle, with offices in the Joseph Vance Building, is spending considerable time at Juneau supervising the construction of the new Baranoff Apartment Hotel.

Silas Nelsen's yawl "Marnie," manned by an all-architect-office crew composed of Hubert Bisson, Fred Rice and Ed "Bud" Borhek, took second place in the three-day race held September 2-3-4 by the Tacoma Yacht Club.

John T. Jacobsen, Seattle, who has been enjoying a three-month study tour of housing developments in northern Europe following his award of the Edward Langley scholarship, was scheduled to sail from Gothenburg, Sweden, on September 13.

Robert L. Durham, architect of Seattle and Tacoma, has recently returned from the national FHA office in Washington, D.C., where he spent a month training for residential cost analysis.

Donald J. Stewart, Vancouver, Wn., and **Jamieson Parker**, Portland, Ore., are architect members of a joint Oregon-Washington committee of six members appointed by George F. Yantis, chairman of the Pacific Northwest Regional Planning Commission, to prepare a comprehensive program for the preservation of the natural beauties of the Columbia Gorge.

George Wolff, member of Cash & Wolff, architects, Railway Exchange Building, Portland, returned to his office late in July after spending five months designing buildings for the construction camp at the Grand Coulee Dam.

Ralph H. Cushing and **Everett O. Terrell** have opened offices for the practice of architecture at 216-217 Treasure State Building, Billings, Mont. Mr. Terrell is a graduate of the University of Washington school of architecture, while Mr. Cushing is a graduate of the University of Michigan in architectural engineering.

Ernest Born, architect, is now located at 730 Montgomery Street, San Francisco, where he has attractive offices finished along modern lines.

COALINGA SCHOOL BUILDING

Bids have been taken for the construction of a \$200,000 grammar school building for the Coalinga Elementary School District, from plans by W. D. Coates, Rowell Building, Fresno. Construction will be of reinforced concrete.

GAS EXHIBIT AT GOLDEN GATE EXPOSITION

(Concluded from Page 56)

Because it is not possible for spectators to go onto the stages, provision has been made for them to see and handle these same appliances in the public concourse, where four great panels are arranged along the wall, each designed around a gas service—cooking, water heating, refrigeration and house heating.

To the left of the concourse is an attractive exhibit of automatic storage water heaters, where each appliance is given individual showing. Adjacent will be a thoroughly planned educational exhibit of "Everdure" metal by the American Brass Co.

Along the main aisle will be the domestic central heating and air conditioning equipment exhibit. Here also will be shown various floor type furnaces, consoles, etc. The theme here is "Modernized Basements and Play Rooms."

Across the aisle will be the kitchen planning studio, which will include a well laid out reference kitchen where the better quality materials for use in kitchen modernization will be shown in actual application. Another feature of the studio will be the reference book alcove, suitably furnished with a large table and chairs for the convenience of those interested in deeper research into possible appointments for their own home kitchen plans. Here also will be ample wall space for the exhibit of prize kitchens, picture contests, etc.

The planning studio will be a pleasant place, having facilities for three designers. Each designer will be supplied with a set of one-inch scale models with which to actually build the applicant's kitchen as she looks on, using such sections for storage, convenience and arrangement as she may decide are best suited to her needs. Should any question arise as to some particular material or finish, the reference kitchen is readily at hand as an example of application.

A dinette alcove has been provided where suggestions for meal serving and table decorations and arrangement are available for such programs.

Design and construction of the cooperative gas industry exhibit is under the direction of L. E. Lindsay, a Gold Medal designer in San Francisco's Panama Pacific Exposition.

MORE HONORS FOR WURSTER

William W. Wurster, architect of San Francisco, was among the nineteen Americans to receive awards from the French Government in the photographic exhibit of American architecture in the United States Pavilion at the Paris International Exposition. Mr. Wurster received a bronze medal for the Frederick Benner residence in Berkeley and the Frank McIntosh residence in Santa Clara.

Estimator's Guide

Giving Cost of Building Materials, Wage Scale, Etc.

Amounts given are figuring prices and are made up from average quotations furnished by material houses to San Francisco contractors. 3% Sales Tax on all materials but not labor.

All prices and wages quoted are for San Francisco and the Bay District. There may be slight fluctuation of prices in the interior and southern part of the state. Freight cartage at least, must be added in figuring country work.

Bond—1/2% amount of contract.

Brickwork—

Common, \$40 to \$45 per 1000 laid, (according to class of work).
Face, \$100 to \$110 per 1000 laid, (according to class of work).
Brick Steps, using pressed brick, \$1.25 lin. ft.
Brick Veneer on frame buildings, \$.75 sq. ft.
Common f.o.b. cars, \$14.00 at yard. Cartage extra.
Face, f.o.b. cars, \$45.00 to \$50.00 per 1000, carload lots.

HOLLOW TILE FIREPROOFING (f.o.b. job)

3x12x12 in. \$ 84.00 per M
4x12x12 in. 94.50 per M
6x12x12 in. 126.00 per M
8x12x12 in. 225.00 per M

HOLLOW BUILDING TILE (f.o.b. job)

carload lots.
8x12x5/2 \$ 94.50
6x12x5/2 73.50

Building Paper—

1 ply per 1000 ft. roll \$3.50
2 ply per 1000 ft. roll 5.00
3 ply per 1000 ft. roll 6.25
Brownskin, 500 ft. roll 4.50
Brownskin, Pro-tect-a-mat, 1000 ft. roll 9.00
Siskraft, 500 ft. roll 5.00
Sash cord com. No. 7 \$1.20 per 100 ft
Sash cord com. No. 8 1.50 per 100 ft
Sash cord spot No. 7 1.90 per 100 ft
Sash cord spot No. 8 2.25 per 100 ft
Sash weights cast iron, \$50.00 ton.
Nails, \$3.50 base.
Sash weights, \$45 per ton.

Concrete Work (material at San Francisco bunkers)—Quotations below 2000 lbs. to the ton, \$2.00 delivered.

No. 3 rock, at bunkers..... \$1.45 per ton
No. 4 rock, at bunkers..... 1.45 per ton
Elliott top gravel, at bunkers 2.10 per ton
Washed gravel, at bunkers... 1.45 per ton
Elliott top gravel, at bunkers 2.10 per ton
City gravel, at bunkers..... 1.45 per ton
River sand, at bunkers..... 1.40 per ton
Delivered bank sand..... 1.00 cu. yd.

Note—Above prices are subject to discount of 2% per ton on invoices paid on or before the 10th of month, following delivery.

SAND

Del Monte \$1.75 to \$3.00 per ton.
Fen Shall Beach (car lots, f.o.b. Lake Meadella), \$2.75 to \$4.00 per ton.

Cement (paper sacks) \$3.00 bbl., warehouse or delivery.

Car-load lots delivered \$2.70, f.o.b. cars

\$2.52

(Cloth sacks) \$3.00 bbl..

Rebate 10 cents bbl, cash in 15 days.

Atlas White 1 to 100 sacks, \$1.50 sack,
Calaveras White } warehouse or delivery; over 100
Medusa White } sacks, \$1.25; 2% discount 10th
of month.

Forms, Labors average \$40.00 per M.

Average cost of concrete in place, exclusive of forms, 35c per cu. ft.; with forms, 60c.

4-inch concrete basement floor

..... .12/2c to 14c per sq. ft.

Rat-proofing 7/2c

Concrete Steps \$1.25 per lin. ft.

Dampproofing and Waterproofing—

Two-coat work, 20c per yard.

Membrane waterproofing—4 layers of saturated felt, \$4.50 per square.

Hot coating work, \$1.80 per square.

Medusa Waterproofing, 15c per lb., San Francisco Warehouse.

Tricoccol waterproofing.

Electric Wiring—\$12.00 to \$15.00 per outlet for conduit work (including switches).

Knob and tube average \$3.50 per outlet.

Elevators—

Prices vary according to capacity, speed and type. Consult elevator companies. Average cost of installing an automatic elevator in four-story building, \$2800; direct automatic, about \$700.

Excavation—

Sand, 60 cents; clay or shale \$1 per yard.

Teams, \$12.00 per day.

Trucks, \$22 to \$27.50 per day.

Above figures are an average without water. Steam shovel work in large quantities, less; hard material, such as rock, will run considerably more.

Fire Escapes—

Ten-foot galvanized iron balcony, with stairs, \$115 installed on new buildings; \$140 on old buildings.

Floors—

Composition Floors—22c to 40c per sq. ft.

In large quantities, 10c per sq. ft. laid.

Mosaic Floors—80c per sq. ft.

Duraflex Floor—23c to 30c sq. ft.

Rubber Tile—50c to 75c per sq. ft.

Terazo Floors—45c to 60c per sq. ft.

Terazo Steps—\$1.60 lin. ft.

Hardwood Flooring (delivered to building)—

1 1/2"x2 1/2" T. & G. Maple \$ 88.00 M ft.

1 1/2"x2 1/2" T. & G. Maple 115.00 M ft.

3/4"x3 1/2" sq. edge Maple 100.00 M ft.

	1 1/2"x2 1/2"	3/4"x2"	1 1/2"x2"
	T & G	T & G	sq. Ed.
Clr. Qtd. Oak	\$120.00 M	\$ 85.50 M	\$110 M
Sel. Qtd. Oak	99.00 M	69.50 M	84 M
Clr. Pla. Oak	106.00 M	74.50 M	86 M
Sel. Pla. Oak	97.00 M	62.50 M	76 M
Clear Maple	111.00 M	100.00 M	
Laying & Finishing	14c ft.	12c ft.	10c ft.
Wage—Floor layers,	\$10.00.		

Note—Above quotations are all board measure except last column which is sq. ft.

Glass (consult with manufacturers)—

Double strength window glass, 20c per square foot.

Plate 75c per square foot (unglazed) in place, \$1.00.

Art, \$1.00 up per square foot.

Wire (for skylights), 40c per sq. foot.

Obscure glass, 30c square foot.

Glass bricks, \$2.40 per sq. ft., in place.

Note—If not stipulated add extra for setting.

Heating—

Average, \$1.90 per sq. ft. of radiation, according to conditions.

Warm air (gravity) average \$40 per register.

Forced air, average \$60 per register.

Iron—Cost of ornamental iron, cast iron, etc., depends on designs.

Lumber (prices delivered to bag, site).

No. 1 common \$29.00 per M
No. 2 common 27.00 per M
Select O. P. common 34.00 per M
2x4 No. 3 form lumber 24.00 per M
1x4 No. 2 flooring VG 55.00 per M
1x4 No. 3 flooring VG 47.00 per M
1x6 No. 2 flooring VG 60.00 per M
1/4"x4 and 6, No. 2 flooring 60.00 per M

Slash grain—

1x4 No. 2 flooring \$43.00 per M
1x4 No. 3 flooring 40.00 per M
No. 1 common run T. & G. 30.00 per M
Lath 5.25 per M

Shingles (add cartage to price quoted)—

Redwood, No. 1 \$1.10 per bdle.
Redwood, No. 2 90 per bdle.
Red Cedar 1.10 per bdle

Plywood—Douglas Fir (add cartage)—

"Plyscord" sheathing (unsanded)

5/16" 3 ply and 45"x96" \$30.00 per M

Wallboard Grade (sound one side)—

1 1/2" 3-ply 48"x95" \$37.50 per M

Concrete Form Panels (special core & glue)

3/4" 5-ply 48"x96" \$110.00 per M

If oiled \$5.00 extra per M

Millwork—Standard.

O. P. \$85.00 per 1000. R. W., \$90.00

per 1000 (delivered).

Double hung box window frames, average with trim, \$6.50 and up, each.

Doors, including trim (single panel, 1 3/4 in. Oregon pine) \$8.00 and up, each.

Doors, including trim (five panel, 1 3/4 in. Oregon pine) \$6.00 each.

Screen doors, \$3.50 each.

Patent screen windows, 25c a sq. ft.

Cases for kitchen pantries seven ft. high per lineal ft., \$8.00 each.

Dining room cases, \$8.00 per lineal foot. Rough and finish about 75c per sq. ft.

Labor—Rough carpentry warehouse heavy framing (average) \$17.50 per M.

For smaller work average \$35.00 to \$45.00 per 1000.

MORE PERSONALS

George W. Groves, Seattle, has moved his office to Room 309, Textile Tower, from Room 1402 in the same building.

Donald N. McDonald, Seattle, with offices in the Joseph Vance Building, is spending considerable time at Juneau supervising the construction of the new Bar-noff Apartment Hotel.

Silas Nelsen's yawl "Marnie," manned by an all-architect-office crew composed of Hubert Bisson, Fred Rice and Ed "Bud" Borhek, took second place in the three-day race held September 2-3-4 by the Tacoma Yacht Club.

John T. Jacobsen, Seattle, who has been enjoying a three-month study tour of housing developments in northern Europe following his award of the Edward Langley scholarship, was scheduled to sail from Gothenburg, Sweden, on September 13.

Robert L. Durham, architect of Seattle and Tacoma, has recently returned from the national FHA office in Washington, D.C., where he spent a month training for residential cost analysis.

Donald J. Stewart, Vancouver, Wn., and **Jamieson Parker**, Portland, Ore., are architect members of a joint Oregon-Washington committee of six members appointed by George F. Yantis, chairman of the Pacific Northwest Regional Planning Commission, to prepare a comprehensive program for the preservation of the natural beauties of the Columbia Gorge.

George Wolff, member of Cash & Wolff, architects, Railway Exchange Building, Portland, returned to his office late in July after spending five months designing buildings for the construction camp at the Grand Coulee Dam.

Ralph H. Cushing and **Everett O. Terrell** have opened offices for the practice of architecture at 216-217 Treasure State Building, Billings, Mont. Mr. Terrell is a graduate of the University of Washington school of architecture, while Mr. Cushing is a graduate of the University of Michigan in architectural engineering.

Ernest Born, architect, is now located at 730 Montgomery Street, San Francisco, where he has attractive offices finished along modern lines.

COALINGA SCHOOL BUILDING

Bids have been taken for the construction of a \$200,000 grammar school building for the Coalinga Elementary School District, from plans by W. D. Coates, Rowell Building, Fresno. Construction will be of reinforced concrete.

GAS EXHIBIT AT GOLDEN GATE EXPOSITION

(Concluded from Page 56)

Because it is not possible for spectators to go onto the stages, provision has been made for them to see and handle these same appliances in the public concourse, where four great panels are arranged along the wall, each designed around a gas service—cooking, water heating, refrigeration and house heating.

To the left of the concourse is an attractive exhibit of automatic storage water heaters, where each appliance is given individual showing. Adjacent will be a thoroughly planned educational exhibit of "Everdure" metal by the American Brass Co.

Along the main aisle will be the domestic central heating and air conditioning equipment exhibit. Here also will be shown various floor type furnaces, consoles, etc. The theme here is "Modernized Basements and Play Rooms."

Across the aisle will be the kitchen planning studio, which will include a well laid out reference kitchen where the better quality materials for use in kitchen modernization will be shown in actual application. Another feature of the studio will be the reference book alcove, suitably furnished with a large table and chairs for the convenience of those interested in deeper research into possible appointments for their own home kitchen plans. Here also will be ample wall space for the exhibit of prize kitchens, picture contests, etc.

The planning studio will be a pleasant place, having facilities for three designers. Each designer will be supplied with a set of one-inch scale models with which to actually build the applicant's kitchen as she looks on, using such sections for storage, convenience and arrangement as she may decide are best suited to her needs. Should any question arise as to some particular material or finish, the reference kitchen is readily at hand as an example of application.

A dinette alcove has been provided where suggestions for meal serving and table decorations and arrangement are available for such programs.

Design and construction of the cooperative gas industry exhibit is under the direction of L. E. Lindsay, a Gold Medal designer in San Francisco's Panama Pacific Exposition.

MORE HONORS FOR WURSTER

William W. Wurster, architect of San Francisco, was among the nineteen Americans to receive awards from the French Government in the photographic exhibit of American architecture in the United States Pavilion at the Paris International Exposition. Mr. Wurster received a bronze medal for the Frederick Benner residence in Berkeley and the Frank McIntosh residence in Santa Clara.

Estimator's Guide

Giving Cost of Building Materials, Wage Scale, Etc.

Amounts given are figuring prices and are made up from average quotations furnished by material houses to San Francisco contractors. 3% Sales Tax on all materials but not labor.

All prices and wages quoted are for San Francisco and the Bay District. There may be slight fluctuation of prices in the interior and southern part of the state. Freight cartage at least, must be added in figuring country work.

Bond—1/2% amount of contract.

Brickwork—

- Common, \$40 to \$45 per 1000 laid, (according to class of work).
- Face, \$100 to \$110 per 1000 laid, (according to class of work).
- Brick Steps, using pressed brick, \$1.25 lin. ft.
- Brick Veneer on frame buildings, \$.75 sq. ft.
- Common f.o.b. cars, \$14.00 at yard. Cartage extra.
- Face, f.o.b. cars, \$45.00 to \$50.00 per 1000, carload lots.

HOLLOW TILE FIREPROOFING (f.o.b. job)

- 3x12x12 in. \$ 84.00 per M
- 4x12x12 in. 94.50 per M
- 6x12x12 in. 126.00 per M
- 8x12x12 in. 225.00 per M

HOLLOW BUILDING TILE (f.o.b. job)

- carload lots.
- 8x12x5/2 \$ 94.50
- 6x12x5/2 73.50

Building Paper—

- 1 ply per 1000 ft. roll \$3.50
- 2 ply per 1000 ft. roll 5.00
- 3 ply per 1000 ft. roll 6.25
- Brownskin, 500 ft. roll 4.50
- Brownskin, Pro-tect-o-mat, 1000 ft. roll 9.00
- Sisalcraft, 500 ft. roll 5.00
- Sash cord com. No. 7 \$1.20 per 100 ft
- Sash cord com. No. 8 1.50 per 100 ft
- Sash cord spot No. 7 1.90 per 100 ft
- Sash cord spot No. 8 2.25 per 100 ft
- Sash weights cast iron, \$50.00 ton.
- Nails, \$3.50 base.
- Sash weights, \$45 per ton.

Concrete Work (material at San Francisco bunkers)—Quotations below 2000 lbs. to the ton. \$2.00 delivered.

- No. 3 rock, at bunkers.....\$1.45 per ton
- No. 4 rock, at bunkers..... 1.45 per ton
- Elliott top gravel, at bunkers 2.10 per ton
- Washed gravel, at bunkers... 1.45 per ton
- Elliott top gravel, at bunkers 2.10 per ton
- City gravel, at bunkers..... 1.45 per ton
- River sand, at bunkers..... 1.40 per ton
- Delivered bank sand..... 1.00 cu. yd.

Note—Above prices are subject to discount of 2% per ton on invoices paid on or before the 10th of month, following delivery.

SAND

- Del Monte \$1.75 to \$3.00 per ton.
- Fan Shell Beach (car lots, f.o.b. Lake Maella), \$2.75 to \$4.00 per ton.

Cement (paper sacks) \$3.00 bbl., warehouse or delivery

Car-load lots delivered \$2.70, f.o.b. cars \$2.52

(Cloth sacks) \$3.00 bbl.

Rebate 10 cents bbl. cash in 15 days.

Atlas White 1 to 100 sacks, \$1.50 sack,
Calaveras White warehouse or delivery, over 100 sacks, \$1.25; 2% discount 10th of month.

Forms, Labors average \$40.00 per M.

Average cost of concrete in place, exclusive of forms, 35c per cu. ft.;

with forms, 60c.

4-inch concrete basement floor

.....12/2c to 14c per sq. ft.

Rat-proofing7/2c

Concrete Steps \$1.25 per lin. ft.

Dampproofing and Waterproofing—

Two-coat work, 20c per yard.

Membrane waterproofing—4 layers of saturated felt, \$4.50 per square.

Hot coating work, \$1.80 per square.

Medusa Waterproofing, 15c per lb., San Francisco Warehouse.

Tricoat waterproofing.

Electric Wiring—\$12.00 to \$15.00 per outlet for conduit work (including switches).

Knob and tube average \$3.50 per outlet.

Elevators—

Prices vary according to capacity, speed and type. Consult elevator companies. Average cost of installing an automatic elevator in four-story building, \$2800; direct automatic, about \$700.

Excavation—

Sand, 60 cents; clay or shale \$1 per yard.

Teams, \$12.00 per day.

Trucks, \$22 to \$27.50 per day.

Above figures are an average without water. Steam shovel work in large quantities, less; hard material, such as rock, will run considerably more.

Fire Escapes—

Ten-foot galvanized iron balcony, with stairs, \$115 installed on new buildings; \$140 on old buildings.

Floors—

Composition Floors—22c to 40c per sq. ft. in large quantities, 16c per sq. ft. laid.

Mosaic Floors—80c per sq. ft.

Duraflex Floors—23c to 30c sq. ft.

Rubber Tile—50c to 75c per sq. ft.

Terazzo Floors—45c to 60c per sq. ft.

Terazzo Steps—\$1.60 lin. ft.

Hardwood Flooring (delivered to building)—

- 1 1/2"x2 1/4" T & G Maple \$ 89.00 M ft.
- 1 1/2"x2 1/4" T & G Maple 115.00 M ft.
- 7/8"x3 1/2" sq. edge Maple 100.00 M ft.

	1 1/2"x2 1/4"	3/4"x2 1/2"	3/4"x2 1/2"
	T & G	T & G	Sq. Ed.
Cir. Qtd. Oak	\$120.00 M	\$ 82.50 M	\$110 M
Sel. Qtd. Oak	99.00 M	69.50 M	84 M
Cir. Pla. Oak	106.00 M	74.50 M	86 M
Sel. Pla. Oak	97.00 M	67.50 M	76 M
Clear Maple	111.00 M	100.00 M	
Laying & Finishing	14c ft.	12c ft.	10c ft.
Wage—Floor layers,	\$10.00.		

Note—Above quotations are all board measure except last column which is sq. ft.

Glass (consult with manufacturers)—

Double strength window glass, 20c per square foot.

Plate 75c per square foot (unglazed) in place, \$1.00.

Art, \$1.00 up per square foot.

Wire (for skylights), 40c per sq. foot.

Obscure glass, 30c square foot.

Glass bricks, \$2.40 per sq. ft., in place.

Note—If not stipulated add extra for setting.

Heating—

Average, \$1.90 per sq. ft. of radiation, according to conditions.

Warm air (gravity) average \$40 per register.

Forced air, average \$60 per register.

Iron—Cost of ornamental iron, cast iron, etc., depends on designs.

Lumber (prices delivered to blog, site).

No. 1 common	\$29.00 per M
No. 2 common	27.00 per M
Select O. P., common	34.00 per M
2x4 No. 3 form lumber	24.00 per M
1x4 No. 2 flooring VG	55.00 per M
1x4 No. 3 flooring VG	47.00 per M
1x6 No. 2 flooring VG	60.00 per M
1 1/4x4 and 6, No. 2 flooring	69.00 per M

Slash grain—

1x4 No. 2 flooring	\$43.00 per M
1x4 No. 3 flooring	40.00 per M
No. 1 common run T. & G.	30.00 per M
Lath	5.25 per M

Shingles (add cartage to price quoted)—

Redwood, No. 1	\$1.10 per bble
Redwood, No. 2	.70 per bble
Red Cedar	1.10 per bble.

Plywood—Douglas Fir (add cartage)—

"Plyscord" sheathing (unsanded)	
5/16" 3-ply and 48"x96"	\$30.00 per M
Wallboard Grade (sound one side)—	
1 1/2" 3-ply 48" x 96"	\$37.50 per M
Concrete Form Panels (special core & glue)	
3/8" 5-ply 48" x 96"	\$110.00 per M
If oiled	\$5.00 extra per M

Millwork—Standard.

O. P. \$85.00 per 1000. R. W., \$90.00 per 1000 (delivered).

Double hung box window frames, average with trim, \$6.50 and up, each.

Doors, including trim (single panel, 1 1/4 in. Oregon pine) \$8.00 and up, each.

Doors, including trim (five panel, 1 1/2 in. Oregon pine) \$6.00 each.

Screen doors, \$3.50 each.

Parent screen windows, 25c a sq. ft.

Cases for kitchen pantries seven ft. high per lineal ft., \$8.00 each.

Dining room cases, \$8.00 per lineal foot

Rough and finish about 75c per sq. ft.

Labor—Rough carpentry warehouse heavy framing (average) \$17.50 per M.

For smaller work average \$35.00 to \$45.00 per 1000.

Marble—(See Dealers)

Painting—

Two-coat work	36c per yard
Three-coat work	50c per yard
Cold Water Painting	10c per yard
Whitewashing	4c per yard
Turpentine, 65c per gal., in 5 gal. cans, and 55c per gal. in drums.	
Raw Linseed Oil—97c gal. in bbls.	
Boiled Linseed Oil—\$1.00 gal. in bbls.	
Medusa Portland Cement Paint, 20c per lb.	

Pioneer or Dutch Boy White Lead in Oil (in steel kegs).

	Per Lb.
1 ton lots, 100 lbs. net weight.....	10/4c
500 lbs. and less than 1 ton lots.....	10/2c
Less than 500 lb. lots.....	11c

Pioneer or Dutch Boy Red Lead and Litharge (in steel kegs).

1 ton lots, 100 lb. kegs, net weight.....	10/4c
500 lbs. and less than 1 ton lots.....	10/2c
Less than 500 lb. lots.....	11c

Pioneer Red Lead in Oil (in steel kegs)

1 ton lots, 100 lb. kegs, net weight.....	11/4c
500 lbs. and less than 1 ton lots.....	11/2c
Less than 500 lb. lots.....	12c

Note—Availability and conditions cause some variance in costs.

Patent Chimneys—

6-inch	\$1.25 lineal foot
8-inch	1.75 lineal foot
10-inch	2.25 lineal foot
12-inch	3.00 lineal foot

Plastering—Interior—

	Yard
1 coat, brown mortar only, wood lath.....	\$0.75
2 coats, lime mortar hard finish, wood lath ..	.80
2 coats, hard wall plaster, wood lath.....	.85
3 coats, metal lath and plaster.....	1.30
Keene cement on metal lath.....	1.30
Ceilings with 3/4 hot roll channels metal lath ..	.75

Ceilings with 3/4 hot roll channels metal lath plastered.....	1.50
Single partition 3/4 channel lath 1 side.....	.85
Single partition 3/4 channel lath 2 sides 2 inches thick.....	1.50
4-inch double partition 3/4 channel lath 2 sides.....	1.30
4-inch double partition 3/4 channel lath 2 sides plastered.....	3.00

Plastering—Exterior—

2 coats cement finish, brick or concrete wall.....	\$1.00
2 coats Calaveras cement, brick or concrete wall.....	1.35
3 coats cement finish, No. 18 gauge wire mesh.....	1.50
3 coats Calaveras finish, No. 18 gauge wire mesh.....	1.75

Wood lath, \$7.50 to \$8.00 per 1000.	
2.5-lb. metal lath (dipped).....	.17
2.5-lb. metal lath (galvanized).....	.20
3.4-lb. metal lath (dipped).....	.22
3.4-lb. metal lath (galvanized).....	.28
3/4-inch hot roll channels, \$72 per ton.	
Finish plaster, \$18.90 ton; in paper sacks.	
Dealer's commission, \$1.00 off above quotations.	
\$13.95 (rebate 10c sack).	
Lime, i.o.b. warehouse, \$2.25 bbl.; cars, \$2.15 lime, bulk (ton 2000 lbs.). \$16.00 ton.	
Wall Board 5 ply, \$50.00 per M.	
Hydrate Lime, \$19.50 ton.	

Plasterers Wage Scale	\$1.25 per hour
Lathers Wage Scale	1.25 per hour
Hot Carriers Wage Scale	1.10 per hour

Composition Stucco—\$1.80 to \$2.00 sq. yard (applied).

Roofing—

From \$70.00 per fixture up, according to grade quantity and runs.	
Roofing—	
"Standard" tar and gravel, \$6.50 per sq. for 30 sqs. or over.	
Less than 30 sqs. \$7.00 per sq.	
Tile, \$20.00 to \$35.00 per square.	
Redwood Shingles, \$7.50 per square in place.	
Copper \$16.50 to \$18.00 per sq. in place	
Cedar Shingles, \$8.00 per sq. in place.	
Recot, with Gravel, \$3.00 per sq.	
Asbestos Shingles, \$15 to \$25 per sq laid.	

Slate, from \$25.00 to \$60.00 per sq. laid according to color and thickness.

Sheet Metal—

Windows—Metal, \$1.75 a sq. foot. Fire doors (average), including hardware \$1.75 per sq. ft.

Skylights—(not glazed)

Copper, 90c sq. ft. (flat). Galvanized iron, 30c sq. ft. (flat). Vented hip skylights 60c sq. ft.

Steel—Structural

\$120 ton (erected), this quotation is an average for comparatively small quantities. Light truss work higher. Plain beams and column work in large quantities \$90 to \$100 per ton.

Steel Reinforcing—

\$80.00 to \$120.00 per ton, set.

Stone—

Granite, average, \$6.50 cu. foot in place. Sandstone, average Blue, \$4.00, Boise \$3.00 sq. ft. in place. Indiana Limestone, \$2.80 per sq. ft. in place.

Store Fronts—

Cooper sash bars for store fronts, corner center and around sides, will average 75c per lineal foot. Note—Consult with agents.

Tile—Floor, Wainscot, etc.—(See Dealers)
Asphalt Tile—18c to 28c per sq. ft. installed.

Wall Tile—

Glazed Terra Cotta Wall Units (single faced) laid in place—approximate prices	
2 x 6 x 12	\$1.00 sq. ft.
4 x 6 x 12	1.15 sq. ft.
2 x 8 x 16	1.10 sq. ft.
4 x 8 x 16	1.30 sq. ft.

Venetian Blinds—

40c per square foot and up. Installation extra.

THE BUILDERS' EXCHANGE OF SAN FRANCISCO STANDARD WAGE SCALE

For mechanics employed on construction work in the Bay Region. Effective September 1, 1937

CRAFT	Journeymen Mechanics
Asbestos Workers	\$ 8.00
Bricklayers (8h-5d)	10.50
Bricklayers' Hodcarriers (6h-5d)	6.75
Cabinet Workers (Outside) (5d)	8.00
Calsson Workers (Open)	6.40
Carpenters (8h-5d)	10.00
Cement Finishers (8h-5d)	10.00
Cork Insulation Workers (8h-5d)	9.00
Electric Workers (8h-5d)	11.00
Electrical Fixture Hangers	8.00
Elevator Constructors	10.40
Engineers, Portable & Hoisting	9.00
Glass Workers (8h-5d)	9.68
Hardwood Floormen	9.00
Housemiths, Architectural Iron (Shop) (8h-5d)	9.00
Housemiths, Architectural Iron (Outside) (8h-5d)	10.00
Housemiths, Reinforced Concrete or Rodmen (8h-5d)	10.00
Iron Workers (Bridge and Structural) Including Engineers (8h-5d)	12.00

CRAFT	Journeymen Mechanics
Laborers, Building (8h-5d)	\$ 6.00
Laborers, Common (8h-5d)	6.00
Lathers, Channel Iron (6h-5d)	9.00
Lathers, All Others	9.00
Marble Setters (8h-5d)	10.50
Marble Setters' Helpers (8h-5d)	5.50
Milwright	9.00
Model Makers (\$1.50 per hr-6h)	9.00
Modelers (\$2 per hr-6h)	12.00
Model Casters	7.20
Mosaic and Terrazzo Workers (Outside)	9.00
Painters (8h-5d)	8.50
Painters, Varnishers and Polishers (Outside)	9.00
Pipe Drivers and Wharf Builders	9.00
File Drivers' Engineers	10.00
Plasterers (6h-5d)	10.00
Plasterers' Hodcarriers (6h-5d)	7.50
Plumbers (8h-5d)	11.00
Roofers, Composition (8h-5d)	9.00
Roofers, All Others (8h-5d)	8.00
Sheet Metal Workers (8h-5d)	10.00
Sprinkler Fitters	10.00

CRAFT	Journeymen Mechanics
Steam Fitters (8h-5d)	\$11.00
Stair Builders (8h-5d)	9.00
Stone Cutters, Soft and Granite (8h-5d)	12.00
Stone Setters, Soft and Granite	12.00
Stone Derricks	9.00
Tile Setters (8h-5d)	11.00
Tile Setters' Helpers (8h-5d)	6.50
Tile, Cork and Rubber (8h-5d)	11.00
Welders, Structural Steel Frame on Buildings	9.00
Welders, All Others on Buildings	9.00
Dump Truck Drivers, 2 yards or less	6.00
Dump Truck Drivers, 3 yards	6.50
Dump Truck Drivers, 4 yards	7.00
Dump Truck Drivers, 5 yards	7.00
Dump Truck Drivers, 6 yards	7.50
Truck Drivers of Concrete Mixer Trucks:	
2 yards or less	6.50
3 yards	7.00
4 yards	7.50
5 yards	7.50
6 yards	8.00

GENERAL WORKING CONDITIONS

- Eight hours shall constitute a day's work for all crafts except as otherwise noted.
- Plasterers' Hodcarriers, Bricklayers' Hodcarriers, Roofers' Laborers, and Engineers, Portable and Hoisting, shall start 15 minutes before other workmen, both at morning and at noon.
- Five days, consisting of not more than eight hours a day, on Monday to Friday inclusive, shall constitute a week's work.
- Transportation costs in excess of twenty-five cents each way shall be paid by the contractor.
- Overtime shall be paid as follows: For the first four hours after the first eight hours, time and one-half. All time thereafter shall be paid

- double time. Saturdays (except Laborers), Sundays and holidays, from 12 midnight of the preceding day, shall be paid double time.
- On Saturday, Laborers shall be paid straight time for an eight-hour day.
 - Where two shifts are worked in any twenty-four hours, shift time shall be straight time. Where three shifts are worked, eight hour's pay shall be paid for seven hours on the second and third shifts, allowing one-half hour for lunch.
 - All work, except as noted in paragraph 9, shall be performed between the hours of 8 a.m. and 5 p.m.
 - In emergencies, or where premises cannot be vacated until the close of business, men there

- reporting for work shall work at straight time. Any work performed on such jobs after midnight shall be paid time and one-half up to four hours of overtime and double time thereafter, provided, that if a new crew is employed on Saturdays, Sundays or holidays which has not worked during the five preceding days, such crew shall be paid time and one-half.
- Recognized holidays to be: New Year's Day, Decoration Day, Fourth of July, Labor Day, Admission Day, Thanksgiving Day, Christmas Day.
 - Men ordered to report for work for whom no employment is provided, shall be entitled to two hours' pay.

MODERNIZED PRODUCTS

Brief Notes on New Materials and Equipment in the Building Industry.

107. SCREWS AND BOLTS

A little booklet put out by the Rawlplug Company, illustrating "Rawl-plugs," a special type of screws and bolts, contains some interesting information. This booklet may be had by sending in the coupon.

108. PORCELAIN ENAMEL

"Enamellers Reference" number 2, is the title of a booklet just issued by the Porcelain Enamel and Manufacturing Company. Written by the manager of the technical operations division of this company, this booklet is most informative. Send for your copy.

109. MAPLE FLOORING

A new "Bruce Every Month" has just been received. Issued by the E. L. Bruce Company, this is always a welcome addition to the modernized products page. It's all about maple flooring.

110. MODERN PLASTICS

One of the finest catalogs to come to our attention of late is the copy of "Modern Plastics." Issued by the publishing house, Breskin and Charlton, it contains 300 pages of text and illustrations. Send for your copy by clipping the coupon.

111. COPPER PIPE

The Mueller Brass Company has issued a new catalog on copper pipe and solder fittings for plumbing and heating. It is very well arranged and illustrated.

112. QUIET FLUSH VALVES

From the Sloan Valve Company comes word of their new product "Flush Valves with Quiet Equipment." Send the coupon for data covering this important feature of plumbing valves.

113. FLOOR WAX

A non-slip wax for floors is described in a booklet issued by the Flex-rock Company. This product is a safety feature for all floor surfaces.

114. ENGINEERED LUMBER

The Wheeler Osgood Sales Corporation has issued a brochure on Laminex Plyform, an engineered lumber. Send the coupon for your copy of this interesting data.

115. INDIRECT LIGHTING

From the Chase Brass and Copper Company comes a new broadside illustrating "The Midas Line"—semi-indirect lighting fixtures with plastic bowls. This new line has some very distinctive features to add to modern lighting.

116. PARTITIONS

A booklet giving the details of "Steelcrete" and Bar-Z-System partitions has been recently issued by the Consolidated Expanded Metals Company. Send the coupon for your copy.

117. WELDING

Another Oxy-Acetylene Tips, the magazine devoted to modern welding is here now. Issued by the Linde Air Products Company.

118. SHOW WINDOW LAMPS

The Westinghouse Electric and Manufacturing Company announces a new Mazda Lamp primarily for use in show windows. Descriptive matter about this new lamp may be had by sending in the coupon.

119. SHOWER RECEPTORS

The Washfountain Company has issued a broadside with information concerning their group shower receptors and soap dispensers. These products are the latest developments in such accessories.

120. GAS AIR CONDITIONER

Airtemp, Incorporated, a Chrysler subsidiary, has issued some illustrative material featuring a new gas burning air conditioner. Send for this data by clipping the coupon.

121. FORM COATING

You will be interested in this pamphlet on "Formoil," a mineral oil coating for concrete forms . . . makes stripping of lumber forms easier and economical and leaves a smooth concrete surface. Use coupon now.

FREE FOR THE ASKING

Check items on coupon, paste on letter head or postal card, and mail to Architect and Engineer.

| Architect and Engineer
 | 68 Post Street
 | San Francisco, Calif.

| Please send me literature on the following
 | items as checked below. This request
 | places me under no obligation.

| 107 114
 | 108 115
 | 109 116
 | 110 117
 | 111 118
 | 112 119
 | 113 120
 | 121

| My Name _____
 | Name of Company _____
 | Street _____
 | City _____ State _____

BUILDING COSTS UP, BANK BOARD REPORTS

MANY "most encouraging" factors are noted in the outlook for new home building during the autumn and early winter, the Federal Home Loan Bank Board reports.

Demand for home loans from savings and loan associations remains excellent as summer weather wanes; home building continues at a healthy pace; urban foreclosures are decreasing rapidly in volume; lending institutions report a sharp drop in real estate held (properties they had acquired through foreclosure).

There are some other factors which are not so encouraging, such as an increase in building costs, both materials and labor, but these factors have had no important bearing on the general home building and financing trend as yet, it was stated. It is hoped here that the usual seasonal declines in construction and financing will tend to be less than usual owing to the trend.

A report compiled for the Board by its Division of Research and Statistics shows that home foreclosures in cities and towns in the United States during July declined 14.9 per cent from the June figure and 30.7 per cent below foreclosures for July, 1937. The decline has been steady for many months but this was an exceptionally substantial decrease. Total urban foreclosures were estimated at 9,144 for July.

The drop in foreclosures was national rather than sectional, as shown by the fact that decreases were reported for 33 states and the District of Columbia; increases of a few foreclosures were reported for 12 states and there was no change for three states.

One of the favorable factors noted was the climb in house rentals during recent months. The rental index figure (1926 equals 100) rose from 62 in 1933 to 84 for the first six months of 1938. On this important phase of the investment home building market, as contrasted with individual home owning, the current Federal Home Loan Bank Review says:

"The relatively favorable position that the owners of rental properties have held during the past year has been an important factor contributing to the improved real estate market. In the face of rather rapid declines in building costs (through the winter and early months of 1938) rents paid on occupied dwellings have continued to increase. Speculative builders and many potential home owners realize that a shortage of adequate and habitable quarters has accumulated during the depression years, and that unless another major depression occurs the pressure caused by the demand for new housing facilities must be relieved somewhat in the next few years. With relatively high rents being received in recent months, and with lower construction costs, many more residential units have been built than last year when a much higher capital outlay was necessary to provide a new house."

In connection with building costs, the Review has pointed out that costs in August increased for the first time in a year and that the outlook seems to be for higher costs.

As indicative of the major position held by savings and loan associations in home financing, the Board stated that from 1925 through 1937, these thrift and home-financing institutions made in each year from a minimum of 46 per cent to a maximum of 68 per cent of all loans negotiated in those years by private financial institutions.

Savings and loan associations thus maintained an annual average of about one-half of the total dollar volume of new urban home mortgage loans so made in this 13-year period. General reports from members of the Federal Home Loan Bank System show that the demand on them for home financing funds continues to be strong in practically all sections of the country even though fall weather is beginning.

GORDON B. KAUFMANN, FELLOW

Presentation of a Certificate of Fellowship in the American Institute of Architects to Gordon B. Kaufmann featured the monthly meeting of Southern California Chapter of the Institute, held at Pierre's Restaurant in San Marino, September 13. The presentation was made by Myron Hunt.

NEWS SPLASHES!

"**T**ALK about your 'blessed events.'" announced Jed Prouty, father of 20th Century-Fox's famed Jones Family, "the happiest one we've had in many a moon was the day the new Day and Night automatic gas water heater joined the family circle. Hot water? Plenty of it!"



There's real joy, comfort and convenience in having abundant hot water at your split-second command. Replace your old heater with a Day and Night, and you have it! Visit your Day and Night dealer or drop us a card for free booklet, "How to Cut Gas Bills 1/3."

DAY and NIGHT
WATER HEATER COMPANY • MONROVIA, CALIFORNIA

CONGRESS DISCUSSES STATE BUILDING LAWS

THE first meeting of the Construction Congress, Northern Section, California State Chamber of Commerce, under the new leadership of Harry M. Michelsen, architect, was held August 25 with an attendance of 34. Mr. Michelsen, in taking up his new duties, said in part:

This is my first meeting as chairman of this group which has been conducted most effectively under the chairmanship of P. M. Sanford for the past six years. Mr. Sanford felt that he had served in this capacity long enough. I was asked to take the job and accepted with the feeling that I would have the full cooperation of the various organizations and interests in the construction industry. I am, therefore, glad to give my best efforts in carrying forward this excellent program in the interests of improving conditions in the construction industry throughout California.

As you all know, for the past three legislative sessions a large number of bills have been before the State Legislature that had an important bearing on the welfare of our industry. At the last session more than one hundred bills were carefully considered by this group and action was taken in opposition to seventeen of these measures while nine bills received our approval.

The plan we have followed in the past has been to circularize trade and professional organizations, business and industrial groups, explaining the various legislative proposals and obtaining their active cooperation through contacts with the Legislature, as well as by correspondence, telephone, telegraph, and personal attendance at legislative meetings in Sacramento in support of our actions. State Chamber executives stationed at Sacramento also worked closely with representatives of construction industry groups in following these particular measures through the Legislature.

With the end in view of obtaining more effective statewide support of the actions of our group at future sessions of the State Legislature, in October, 1937, we secured the support of the Industrial Committee and approval of the board of directors of the State Chamber to six basic policies on construction legislation which will serve as a guide to the board of directors in taking quick action on future recommendations of our group on bills before the Legislature. These policies do not cover the entire field, but they do serve as a good basis for our future actions, and, of course, may be supplemented with new policies as special problems arise.

The adoption of these policies by the State Chamber makes it unnecessary for the Board to pass upon individual bills, but merely to be assured that they fall within these existing policies. This should result in obtaining quicker action, more effective statewide support and greater efficiency in our efforts at future sessions of the Legislature."

Field Act

George B. McDougall, State Architect, reported that the administration of the Field Act is proceeding satisfactorily, with an increased understanding of its provisions by the public. He did not anticipate any serious changes to the present Act. He referred to the activities of the Review Board, composed of eight architects and engineers in addition to three ex-officio members. He stated that the Board meets every two months and thus far in every case the judgment of the Board has been accepted.

Riley Act

C. H. Kromer, Chief Engineer of the State Division of Architecture, emphasized the fact that the Riley Act was not administered by the State Division of Architecture. He stated, however, that in certain cases where standards had not been set, and upon request the Division had furnished suggested standards to be used in the administration of the Act.

State Housing Act

Mr. Mott, Supervisor of Housing of the State Division of Immigration and Housing, reported that twenty-one amendments were made to the State Housing Act at the last session of the Legislature, and expressed appreciation to the State Chamber in support of these amendments, and that the most important amendment referred to enforcement outside of cities. He said that



IN DEFENSE OF BEAUTY

SPECIFY DUTCH BOY PAINTER PRODUCTS

Client and painting contractor alike will applaud these trustworthy guardians of the beauty you create. Here is a group of products which will afford that so-much-to-be-desired combination of surface protection and durable paint beauty.

For specific formulas consult your National Lead Company Specification Book . . . for technical service and information —

ASK THE NATIONAL LEAD MAN

San Francisco • Los Angeles • Seattle • Portland
BRANCHES IN ALL PRINCIPAL CITIES

buildings valued at \$30,000,000 had been constructed outside of cities since 1923; that in 1936 eighteen deaths occurred in buildings outside of cities on account of traps which will be avoided in the future by enforcement of the present Act.

Contractors License Act

S. G. Johnson of Oakland, member of the State Contractors License Board, thanked the State Chamber for its support at the last session of the Legislature of several constructive amendments to the State Act and explained the activities of the newly created Contractors License Board. He said that no recommendations had been made by the Board for further changes in the Act, but he expected the Board would give consideration and submit recommendations at a later date on several provisions of the Act including: Modification of the \$100 exemption; shortening the renewal period which is at present one year; modification of pre-qualification requirements; providing a per diem wage to Board members; and raising the present fee of \$5 to provide for necessary additions to field and office activities. Mr. Eaton spoke on several of these points.

Civil Engineers Act

Henry D. Dewell, president, State Board of Registration for Civil Engineers, reported that the Civil Engineers Act had been enforced since 1929, that thirty-eight states have such acts; that California is one of two states that register only civil engineers. He reported that four years ago a general act was proposed, embracing civil, electrical, mechanical, and mining engineers, but that the act did not come out of committee due to strong opposition on the part of mechanical and mining engineers. He said that after nine years of experience with the Civil Engineers Act, it would be difficult to transpose its principal provisions in a general act without losing many of the present benefits. He said that codification of the act is under way and that a few minor changes had been agreed to.

Architectural Practice Act

Any amendment to the Codification Act regulating the practice of architecture, according to the State Association of California Architects, Northern Section, will in no way interfere with the functions of other professional or educational groups and will provide fees for administration expense. Such amendments will be submitted at a later meeting with recommendations.

Private Practice

Harold B. Hammill, Structural Engineer, San Francisco, reported on changes desired in connection with the constitutional amendment passed in 1923 on the Civil Service Act. He said at that time the seriousness of the Act was not fully realized. He cited two instances where the State refused payment on bills for service by consultants employed by State Departments. The payments were refused on the grounds that the work should have been done by civil service representatives of the State.

Mr. Hague added some very interesting comments citing figures on work now being done by the State

Harbor Board on the waterfront by civil service men, which was previously handled by contract, at much less expense to the State.

Action was taken to the effect that the Construction Congress investigate this problem to the end of having proper changes made.

NEW EPOCH IN ARCHITECTURE

A national architecture marking a new epoch in the history of art will arise from revival in building, Dean Leopold Arnaud of the School of Architecture of Columbia University predicts in his annual report to Dr. Nicholas Murray Butler, president of the University.

Dean Arnaud foresees a promising future for the architectural profession, which, he points out, was the hardest hit of all professional groups during the depression. A quickening of construction activity may result in a shortage of trained men, the Dean warns.

"At present, the profession of architecture is profoundly affected by the economic fluctuations of our day—more so, perhaps, than any other profession," Dean Arnaud says. "In times of depression, doctors and lawyers, for example, still have work to do, though their fees may be diminished; but the architect is left idle, for activity in building ceases.

"In this country since 1930, the plight of architects has been grave. After eight years of depression, the situation is now causing them special concern, not only because of their present inactivity and monetary diffi-

JOHNSON

Since 1904, the name of Johnson on an oil burner has been accepted as the seal of fine engineering, skilled craftsmanship and dependability. Johnson Burners on an architect's specifications insures satisfaction and comfort for the home owner. Johnson builds oil burners for every need of industry, commerce and home. Data sheets on each type of Johnson Improved Burners give complete information and specifications. Johnson engineers will be glad to assist in preparation of layouts & estimates.



THERE'S A JOHNSON OIL BURNER FOR EVERY PURPOSE

AIR-CONDITIONING? See the Johnson SELECTAIR, a compact, efficient unit which offers every desired feature for economical heating, air-conditioning and ventilating the home. With year-round domestic hot water. Oil-fired by the Johnson Pressure-type "Bankheat" Burner.

BOILER-BURNER UNIT? Test the "LADDI DU-ALL", a compact and completely automatic unit furnishing heat and hot water for small and medium-sized homes and apartments at low initial cost. ... Descriptive bulletins on request.

S. T. JOHNSON CO.

940 ARLING T. L., OAKLAND, CALIFORNIA
401 N. BROAD STREET, PHILADELPHIA, PA.

culties, but also because those who look ahead realize that architecture, which houses man in every phase of his living, cannot remain dormant indefinitely, especially as every social change creates new needs in building—and certainly we are witnessing social change.

"Revival may come quickly, in which case there will be a serious shortage of trained men, because many former architects have gone into other fields, while comparatively few new architects have been graduated from the schools. This problem is sufficiently grave to have evoked discussion at the last convention of the American Institute of Architects.

"Since 1932, registration in the schools of architecture in the United States has dropped 30 to 50 per cent, the lowest point having been reached in 1934. Apparently, there are two major causes: First, young men are reluctant to choose a profession which has been so hard hit, and in which the unemployment of draftsmen has been so widely publicized; second, the families of many prospective students, having suffered financial losses, are unable or unwilling to carry the expenses of five or six years of university training.

"As a remedy for the second cause, we can only hope that, despite an already overtaxed budget, some means may be found for granting for a few years at least, additional financial aid and scholarships to deserving students. As a remedy for the first cause, the fact must be made known that this is the time to prepare for a period of activity."

CALIFORNIA BUILDING SECOND IN NATION

California home building, in point of volume and value, is at the highest level in seven years, according to figures compiled by the Bureau of Industrial Service, 285 Madison Avenue, New York.

A decline of \$4.28 in per person building costs last year, the first drop since 1933, helped lift residential construction in thirteen California cities to a volume but slightly below that of 1930, the base year of this housing study.

In a new survey of 41 states and the District of Columbia, California's thirteen cities—which contain 52.83 per cent of the State's population—held second place both in number of homes constructed and their valuations.

The report is based on a housing survey made in 310 cities, comprising more than a third of the nation's population.

The California cities used in this survey are: Alameda, Berkeley, Fresno, Long Beach, Los Angeles, Oakland, Pasadena, Sacramento, San Diego, San Francisco, San Jose, Stockton and Vallejo.

"New residences put up in these California cities," according to C. J. Ryan of the Investor's Syndicate, provided shelter for 72,808 persons during 1937, a gain of 5,484, or 8 per cent, above 1936 home-building. During the seven years ended with 1937, homes erected in these cities sheltered 267,984 persons, or about 74

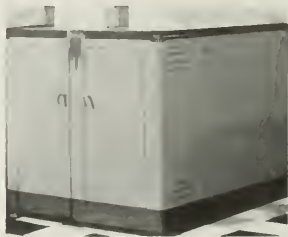

For GAS HEAT choose the DELCO CONDITIONAIR

Built and Backed by General Motors

●This extremely efficient unit automatically warms, purifies, humidifies and circulates the air—supplies complete winter air conditioning to which summer cooling can easily be added. A quality product of unusual efficiency with the plus value of the "General Motors" name. Also models for oil heat. Get complete specifications from —

ALADDIN HEATING CORPORATION

2222 SAN PABLO AVENUE • OAKLAND

STANLEY

THE SYMBOL OF LEADERSHIP
IN DOOR HARDWARE FOR 90 YEARS

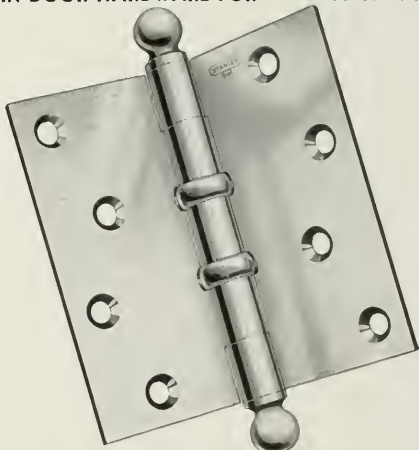

THE STANLEY WORKS
New Britain, Conn.

SAN FRANCISCO
576 Monadnock Bldg.

LOS ANGELES
407 American Bank Bldg.

SEATTLE
568 First Avenue, South

STANLEY

TRADEMARK

HARDWARE FOR CAREFREE DOORS

Do You Plan Houses? — or Homes?

Roofs, floors, walls, make a house. Electrical convenience helps transform that house into a home.

Clients must be favorably impressed with your houses after they have moved in and have lived in them, if you are to build a growing clientele.

Daily living in a house is the acid test of the architect's skill in foreseeing needs and including them in his plans.

In any modern home electricity is used scores of times every day. If the electrical service has not been carefully planned, many of these times every day someone in that home is annoyed because there is not an outlet where it is needed, or the outlet is inconveniently placed, or the lack of a properly placed switch necessitates stumbling around in the dark to find a lamp.

Don't let these inconveniences annoy your clients. See that there is an adequate electrical wiring plan for every house you design.

Our free Red Seal plan gives a minimum standard as a basis from which to work. Free consultation service on wiring problems, too, if you wish.

PACIFIC COAST ELECTRICAL BUREAU

447 Sutter Street
SAN FRANCISCO • CALIFORNIA • LOS ANGELES

601 W. 5th Street

per cent of the 361,927 estimated seven-year population increase."

"Value of the new residences constructed in these thirteen cities during 1937 amounted to \$66,998,856—highest for California in any of the eight years of the survey, and second largest in the national study. This represents an increase of \$4,906,263, or 8 per cent, above 1936 valuations, and is more than \$6,925,062, or 11 per cent, in excess of the total for 1930. Home construction in California in 1937 constituted more than 28 per cent of the total for the seven-year period—1931 to 1937, inclusive, namely, \$235,762,272, second highest in the nation."

PEPPING UP ARCHITECTURE

A deliberate attempt to enliven American architecture and introduce life and gaiety into the monotone scenery of American cities is being made by the New York World's Fair 1939. This was disclosed when details of the Fair's mural project, the largest program of exterior mural painting ever undertaken, were made public by Grover A. Whalen, president of the Fair Corporation.

Leading mural painters in this country and numerous artists in other lands are at work on Fair commissions.

The Fair Corporation itself has 102 murals under way or completed. They utilize a wide variety of methods and represent all schools of the art of today and tomorrow from the conservative to the ultra-radical. Many of them are of impressive dimensions, ranging up to 250 feet in length and 60 feet in height.

Artists commissioned by the Fair Corporation number thirty-two. The list reads like a blue book of American muralists. Each one has been assigned a building or portion of a building. In addition, many industrial exhibitors are following the Fair's example by employing mural painters, while foreign governments are planning elaborate decorations for their pavilions, executed by artists of their own countries.

Nothing even approaching this mural program ever has been attempted before either in an exposition or with permanent buildings, according to Ernest Peixotto, noted mural painter, who is in charge of the project as consultant to the Fair's Board of Design.

ACOUSTIC AND INSULATION PLASTERS

Gladding, McBean & Co. have become exclusive West Coast distributors of the nationally known Kalite products for sound absorption and heat and sound insulation.

The best known of these products is Kalite acoustical plaster, a highly efficient sound absorber. This plaster has been installed in Radio City Theater, New York; United Artists Theater, Berkeley; Los Angeles Times Building, Los Angeles County Hospital; Doheny Memorial Library, University of Southern California, and many other outstanding buildings. It has also been tested and approved by the Bureau of Standards for use in all Federal work.

Of no less importance is Kalite insulating plaster, a product which insulates for both heat and sound. It has great possibilities for use in homes, apartment houses, and offices, and it provides effective insulation at low cost. Other Kalite products include: hand applied acoustical plaster, hand applied insulating plaster, acoustical plaster tile, cast aggregate, hydraulic plaster, acoustical cast stone.

QUIK-ACTION OIL FURNACE

Officials of Delco-Frigidaire Conditioning Division of General Motors Sales Corporation have just released to their national dealer organization an announcement concerning a new heating device, claimed by them to be revolutionary in design. The new product, called a quik-action oil furnace, apparently departs considerably from conventional practice.

The new quik-action oil furnace is a complete furnace, and makes no attempt at conversion. The central feature is a unique metal unit resembling a drum, called a heat transmitter, and built closely around the area of actual combustion. Although placed horizontally, with a baffled opening at the far end, the effect is almost identical to that established when a lamp chimney is placed around an old-fashioned wick flame. Combustion efficiency is increased to a point not hitherto possible in the conventional type oil burner, according to the company's claims.

With the metal heat transmitter in place, immediately surrounding the flame, no refractory material of any kind is used in any part of what is conventionally known as the combustion chamber.

'As a matter of fact,' officials stated, "through the use of the new quik-action heat transmitter, we are able to remove entirely the greatest barrier to efficient transfer of heat. Utilized originally to increase temperatures for the purpose of obtaining more complete combustion, refractory materials at best functioned as insulators which tended to increase undesirable lag at both ends of the operating cycle."

In the new burner, radiant heat, acting directly on the uninsulated inside surfaces of the boiler walls, is the dominant factor in the design.

FIR DOOR INSTITUTE

Formation of the Fir Door Institute with a program of nation-wide trade promotion and product research and development, is announced by J. P. Simpson, newly elected president of the Institute, following the organization meeting.

W. E. Difford was elected managing director of the Institute. The other officers are: H. E. Tenzler, Northwest Door Company, Tacoma Washington, vice-president; E. G. Rice, Monarch Door and Manufacturing Company, Tacoma, secretary; N. O. Cruver, Wheeler-Osgood Sales Corporation, Tacoma, Washington, treasurer. Mr. Simpson is vice-president and general

Welcome to Architects attending Convention of State Association, San Francisco, October 13-15

DALMO SIMPLEX WINDOW FIXTURES

"THE NATION'S SCHOOLHOUSE WINDOW"

HAVE BEEN USED IN OVER 200 SCHOOLS IN CALIFORNIA IN THE PAST TWO YEARS

KRAMER FLUSH VALVES

SHEER SIMPLICITY OF CONSTRUCTION MAKES FOR POSITIVE PERFORMANCE AND LOW MAINTENANCE

MacDONALD  **HARDWARE MANUFACTURING CO.**

YUkon 0123

963 Harrison St.

San Francisco

"Goods of the Woods"

Dependable Building Materials

Lumber and Millwork
for
All Types of Construction

★

Wolmanized or Creosoted Lumber and Timbers is your protection against Termites and Decay

★

E. K. WOOD LUMBER CO.

San Francisco

Los Angeles

Oakland



IT'S NOT A HOME

(Commercial or Private)

WITHOUT

Beautiful Trees and Shrubs

MAKE THE

FACTORIES

WHOLESALE HOUSES

PRIVATE HOMES

Really look like

California

Largest selection of specimen plants in California — from which to plan your proper and liberal planting.

Roy F. Wilcox & Co.

WHOLESALE GROWERS

MONTEBELLO (Los Angeles County) CALIFORNIA

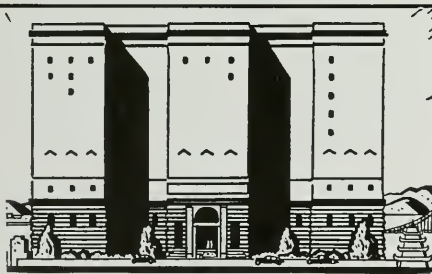

When You're at the
CALIFORNIA ARCHITECTS' CONVENTION

October 13-15

you're at the

FAIRMONT

The delightfully logical place to stay! On Historic Nob Hill! A magnificent view of San Francisco Bay, the new bridges, the 1939 World's Fair on "Treasure Island." Spacious rooms attractively furnished. Gaiety in the chic Circus Lounge and the Venetian Dining Room. Within four minutes of the theater and shopping districts and Chinatown. Garage in the Building.

Rates from \$4 per day.

Your reservations should be made early.

GEORGE D. SMITH, *President*

THE FAIRMONT HOTEL

**Pressure
Treated Lumber?**

Specify

BAXCO CZC

**"Chromated Zinc
Chloride"**

**Protects against decay
and termite attack**

*Available for prompt shipment
throughout California*

J. H. BAXTER & CO.

601 W. 5th Street
LOS ANGELES
Phone MIchigan 6294

333 Montgomery Street
SAN FRANCISCO
Phone DOuglas 3883

manager of the Buffelen Lumber and Manufacturing Company, Tacoma, Washington.

Plans were immediately formulated by the Institute for launching a program of enlarged trade promotion which is designed to widen existing fir door markets and to open up new markets. This will involve the preparation of sales promotional material which will be released at regular intervals in order to keep United States architects, builders, contractors, and the lumber trade generally, informed of major developments in the field of fir door product research. Principal features of this research will be directed toward adapting fir doors to any sustained trend in future architectural design, as well as the study of finishing technique, and structural or other technical engineering problems.

Other aspects of the trade promotional program embrace meetings of industry sales representatives with the trade as one means of educating lumber dealers' and distributors' salesmen in fir doors; direct mail advertising to the principal markets for fir doors; and, at a later date, trade paper advertising.

Featured as the first plank in the program will be the sale of a new upward-acting garage door, the Crawford-Fir-Dor, which will be manufactured by Institute members under the license of the Crawford Door Company of Detroit, Michigan, holders of the patents on the door and manufacturers of the hardware unit. The Crawford-Fir-Dor will be sold as a single unit through lumber distributors and lumber dealers

NAMED ARCHITECTURAL HEAD

Ludwig Mies van der Rohe, world-famous as a founder of the new modern architecture, has joined the faculty of Armour Institute of Technology in Chicago as Professor of Architecture and Director of the School of Architecture. Mies van der Rohe, who is already acquainted with the United States, recently returned from Europe to assume his new duties in Chicago. His appointment constitutes the realization of a plan which has long been under consideration by Institute officials and a committee of prominent Chicago architects. The appointment is in line with the current expansion program of the Institute. It is the first and one of the most important steps designed to make the architectural department of the Institute one of the foremost in the United States.

The committee of Chicago architects under whose direction the step was taken, consists of John A. Holabird, of Holabird & Root, chairman; Alfred Shaw, of Shaw, Naess & Murphy; C. Herrick Hammond State Architect of Illinois, a member of the firm of Brunham Brothers & Hammond; Alfred Alschuler, a trustee of the Institute and president of Alschuler, Inc.; and Jerrold Loebel, acting director of the Institute's school of architecture since 1936, and member of the firm of Loebel & Schlossman.

In the execution of his plans for the school of architecture at Armour Institute, Mies van der Rohe will

No Worry for the Architect

"All acid proof drain pipe and fittings shall be Ferro-silicon—CORROSIRON."

[Write for this specification]



FEDERAL BUILDING • CIVIC CENTER • SAN FRANCISCO

Arthur Brown, Jr., Architect

CORROSIRON DRAIN LINES and FITTINGS and LABORATORY EQUIPMENT was specified because of its superior resistance to corrosion and wear.

Pacific Foundry Company, Ltd.

NEW YORK • 3100 NINETEENTH ST., SAN FRANCISCO • LOS ANGELES

BUILD WELL~

A PROPERLY designed and well constructed building is a credit to any city and a profitable investment for its owner.

Such structures are the STANDARD OIL BUILDING, MATSON BUILDING, FOUR-FIFTY SUTTER STREET, STOCK EXCHANGE, S. F. BASE BALL PARK, MILLS TOWER, OPERA HOUSE and VETERANS' MEMORIAL, San Francisco, OLYMPIC CLUB ALTERATIONS, SANTA ANITA RACING PLANT and other notable structures — all built or supervised by —

Lindgren & Swinerton, Inc.

Standard Oil Building 605 W. Tenth Street
San Francisco Los Angeles

We Maintain a Termite Control Department

POMONA TILES

FOR
Bathrooms and Kitchens
in over 60 colors

Warehouses and Display Rooms

135 Tenth St. San Francisco

629-33 North La Brea Ave. Los Angeles

6106 Roosevelt Way Seattle

POMONA TILE MFG. CO.
PLANT — POMONA, CALIF.



Booklet "The Charm of a Well Lighted Home" available upon request.

ORIGINAL ideas in modern lighting as well as beautiful interpretations of pure period Lightoliers are always available in a wide and interesting variety at Incandescent. Although finely finished and beautifully executed, these selections are priced for today's restricted budgets.

INCANDESCENT SUPPLY CO.

SAN FRANCISCO : OAKLAND : FRESNO : LOS ANGELES

HARER GAS FURNACES HEAT

Consult us for the answer to your problems

HARER-PERRY COMPANY

5662 Keith Ave., Oakland, California

Phone HUmboldt 7928

A Permanent Exposition
of the newest ideas
in home planning
and equipment.



THE BUILDING MATERIAL EXHIBIT

Architects Bldg. • Fifth & Figueroa • Los Angeles • MU-6306

have the assistance of the present architectural staff. In addition, two new professorships will be created—a professorship for city-planning, which will be held by Ludwig Hilberseimer, and a professorship for visual education, which will be held by Walter Peterhans. John B. Rodgers has been chosen as assistant in design.

Mies van der Rohe was born in 1886 in Aix-la-Chapelle. He comes from an old family of stone masons. The handicraft tradition maintained there developed his unusual sense for quality in materials and workmanship. In Berlin he associated himself with Peter Behrens; whose pioneer work gave impetus to the growth of contemporary architecture. He represented Behrens in Leningrad during the execution of the latter's German Embassy there. In Behrens' office Mies van der Rohe worked with Le Corbusier and Gropius, together with whom he later exercised a determining influence upon modern architecture.

Mies van der Rohe's experience was greatly enriched by an extended sojourn in Holland and especially through his acquaintance with Berlage. Berlage brought to his attention Frank Lloyd Wright and the latter's extraordinary architectural achievements.

WPA ARCHITECTURAL SURVEY

The history of New Jersey's architectural growth to 1860 is being compiled by the WPA Historic American Buildings Survey, with 432 buildings already documented, State WPA Administrator Robert W. Allan states in a recent report to Washington, D.C., WPA headquarters.

Many examples of early architecture have been destroyed by fire, razed to provide space for new structures, or so modernized that the original design is defaced. This survey is to perpetuate in photographs, detailed drawings and narrative these specimens for historic record and for use by architects.

The WPA in New Jersey has 120 architects, draftsmen, clerical and research workers employed in thirteen counties. Field workers photograph, make scale and detail working drawings and diagrams. Researchers compile the historic data. From this information, a replica of any building could be constructed.

All records are transmitted to the Congressional Library, Washington, D.C. Blue prints of buildings surveyed may be purchased from the Division of Fine Arts, Congressional Library.

The oldest house surveyed by the New Jersey project is Grovott House, Rancocas, Burlington County, built about 1685.

Among the interesting buildings documented is the Mansion House, on the green at Hackensack, built in 1751 by Peter Zabriskie. A sandstone structure, the walls three feet thick, it was originally two stories with gable roof. A third story was later added, with brick front and clapboard ends.

When the Continental army retreated through Hackensack from Fort Lee to Trenton in 1776, Washington

occupied Mansion House for one week, while his soldiers camped on the green. It was the first headquarters of Washington in New Jersey. In 1800 the house became a tavern, named the "Albany Stage Coach." Lafayette, visiting Hackensack in 1824, occupied Washington's old room. Ten years later it became the town's post office. Elections were held in the ball room. Company C, National Guards, organized there in 1872 and drilled on the green.

Bow, or Beau, Hill House, Deutzville, Mercer County, built by Barnt De Klyn shortly before 1790, is a brick building with one wing and gambrel roof, broken by dormers. De Klyn made a fortune selling cloth for uniforms during the Revolution.

To Bow Hill in 1820, Joseph Bonaparte brought Annetta Savage, his protege, after Philadelphia society refused to accept her. She had operated a glove store in that city where, supposedly, Bonaparte fell in love with her. The house is now owned by the Lalor family, descendants of Barnt De Klyn.

In Camden is the Benjamin Cooper House, a stone frame with stone and brick el, hip and pent roof between first and second floors, built in 1734.

During the British occupation of Philadelphia, winter of 1777, Lieut. Col. Ambercrombie commandeered the house while his troops were stationed at Pyne Point, cutting wood for Philadelphia and for transports.

The Isaac Van Campen House, Old Mine Road, Shapanack, Sussex County, built about 1750, was used as a fort during the French and Indian War, 1755-58. Van Campen, member of the Continental Congress, entertained General Gates on his march from Ticonderoga to reinforce Washington; was host to John Adams several times when the statesman traveled between New England and Philadelphia.

RETURNS FROM PERSIAN EXPEDITION

John B. McCool, San Francisco architect, 1304 Bernal Avenue, Burlingame, has returned from an expedition into Persia and Afghanistan, where he was sent by the American Institute for Persian Art and Archaeology.

Mr. McCool was one of five men who made the trip. Arthur U. Pope of New York headed the expedition, which spent four months in Persia gathering information on Persian architecture dating back to the 10th century. The data eventually will be published.

While in Persia Mr. McCool prepared plans for a palace which the governor of Korassan will build and present to the Shah of Persia.

COLLAPSE OF METAL CEILING

Collapse of a suspended metal lath and plaster ceiling in the study auditorium of the High School at Clarkdale, Arizona, on September 14, caused injuries to twelve pupils requiring treatment in a hospital, and minor cuts and bruises to twenty-six other pupils. County authorities are making an investigation to determine the cause of the collapse.

INCLUDE TREES IN YOUR PLANS

DAVEY, ORIGINATOR OF TREE SURGERY, OFFERS FREE
INSPECTION AND ESTIMATE.



SAN FRANCISCO Fresno LOS ANGELES
Russ Bldg. Mattei Bldg. Story Bldg.
Sutter 3377 Tucker 1929
Local phones in: Pasadena, Palo Alto,
Oakland, San Rafael, San Mateo

SKILL - KNOWLEDGE - RESPONSIBILITY

STRUCTURAL STEEL

For Class A Buildings,
Bridges, etc.

JUDSON PACIFIC CO.

609 MISSION STREET
SAN FRANCISCO

Plants: San Francisco - Oakland

USE BASALITE

Light-weight, pre-fabricated Con-
crete building products for floors,
walls, and roofs in your next
building.

BASALT ROCK COMPANY, INC.

Napa, California

NOISE Control

Office Quieting
Sound-proof Partitions
Acoustical Correction

WESTERN ASBESTOS CO.

Building Materials Mechanical Specialties
SACRAMENTO OAKLAND
SAN FRANCISCO

SHASTA DAM

With construction started on mighty Shasta Dam, the curtain has risen on one of the greatest of all reclamation dramas.

This \$170,000,000 water conservation program was advanced, during the 1937-38 fiscal year recently closed, from vision to reality.

A long series of preliminary investigations were virtually completed, field surveys were well extended on all three divisions, plans were drawn and approved for many major structures, first actual building was begun, and negotiations were conducted to pave the way for heavy construction in the fall of 1938 and in 1939.

For the benefit of prospective workers it is announced that the time of peak employment probably will not be reached for at least two years.

Almost every section of the nation is represented in the \$35,939,450 contract recently awarded to Pacific Constructors, Inc., for building Shasta Dam and Power Plant on the upper Sacramento River near Redding. Notice to proceed under this contract

was issued September 6. Pacific Constructors is a combination of twelve large contracting firms located as follows:

East—The Arundel Corp., Baltimore, Md., and Foley Bros., Inc., New York City.

Middle West—A. Guthrie & Co., St. Paul, Minn., and Hunkin-Conkey Construction Co., Cleveland, Ohio.

South—W. E. Callahan Co. and Gunther & Shirley Co., Dallas, Texas. Rocky Mountains—Shofner, Gordon & Hineman, Denver, Colo., and Lawler & Maguire, Butte, Montana.

West Coast—Griffith Co., Metropolitan Construction Co., American Concrete and Steel Pipe Co., D. W. Thurston Co., and L. E. Dixon Co., all of Los Angeles.

In addition to Shasta Dam, smaller construction contracts have been awarded on the Central Valley Project in the sum of \$1,495,434. These cover the erection of Bureau of Reclamation construction camps near both the Shasta and Friant Dam sites, construction of the first twelve miles of the Contra Costa Canal, boring a diversion tunnel through the west abutment of the Shasta Dam site, and building a warehouse and storage yard in the Sacramento River Canyon below the dam site.

Besides construction work, contracts for materials and supplies have been awarded in excess of \$350,000, and contracts for dam site foundation exploration have been completed for \$150,000.

More than 135 miles of main canal have been located. These include all of the 46-mile Contra Costa Canal, 68 miles of the 160-mile Friant-Kern Canal, and 22 miles of the 40-mile Madera Canal. In addition, approximately 300 miles of traverse have been surveyed on various proposed routes for the San Joaquin Pumping System.

Conceived by engineers as early as 1871, perfected by State and Federal agencies after many years of study, endorsed by vote of the people of California in 1933, and officially adopted by the Federal Government in 1935, the Central Valley Project provides for conservation and equit-

Found . . .

an ideal stop-over place for your drive to or from the State Association of California Architects Convention in San Francisco, October 13, 14, 15.

You will spend a comfortable night in a well appointed room to your liking. Private parking.

Convenient to 101 or drive the new San Simeon scenic highway.

MISSION INN IN HISTORIC MONTEREY



*No longer a problem
for the Architect*

TRANSIT MIX CONCRETE AND MORTAR

makes delivery of material to the job swift and inexpensive . . . minimizing the architect's supervision costs and assuring his client a dependable mix.

Speed . . . Reliability . . . Economy
Let us co-operate with you

Golden Gate-Atlas Materials Co.

16th and Harrison Streets
San Francisco
UNderhill 3650

SISALKRAFT

REG. U. S. PAT. OFF.

**"More than a
building paper"**

THE SISALKRAFT CO.

205 West Wacker Drive
(Canal Station) Chicago, Ill.
55 New Montgomery Street
San Francisco, Calif.

Pacific Manufacturing Company

High Class Interior Finish
Quality Millwork

142 Sansome St. 6820 McKinley Ave.
San Francisco Los Angeles
GARfield 7755 THornwall 4196

1315 Seventh Street, Oakland
GLencourt 7850



CLIENTS will bless you for installing the Wesix "49'er" ELECTRIC BATHROOM HEATER. But try it first in your own home. Certain that you will like its forty-nine inches of INSTANT RADIANT HEAT and QUICK CIRCULATING HEAT, we are offering this smart new heater at factory cost to architects, for personal use! Limit one heater per architect. List price \$21.50. Please write on your regular letterhead, to: 1018 WESIX BLDG., SAN FRANCISCO

WESIX
WESIX ELECTRIC HEATER CO.



**HERRICK
IRON WORKS**

STRUCTURAL STEEL

18TH AND CAMPBELL STS.
OAKLAND, CALIF.
Phone GLencourt 1767

**FORDERER
CORNICE WORKS**

Manufacturers of
Hollow Metal Products
Interior Metal Trim
Elevator Fronts and Gabs
Metal Plaster Accessories
Sanitary Metal Base
Metal Cabinets
Flat and Roll Metal Screens
Commercial Refrigerators

269 POTRERO AVE.
San Francisco, Calif.
HEmlock 4100

able distribution of the Great Central Valley's most precious natural resource—water.

Shasta Dam will create a storage reservoir which will be operated to stabilize the Sacramento River—and thereby diminish floods in the spring, eliminate extreme low flow in the fall, permit a restoration of year-round navigation as far upstream as Red Bluff, afford improved irrigation in the Sacramento Valley, provide constant flushing of the salt-troubled Sacramento-San Joaquin delta, and furnish an adequate supply of fresh water to the delta intakes of the Contra Costa Canal and the San Joaquin pumping system.

The Contra Costa Canal will serve an industrial and agricultural area on the south shore of Suisun Bay as far west as Martinez. The San Joaquin pumping system will carry Sacramento River water up the lower San Joaquin Valley as far as Mendota to replace an equivalent amount of San Joaquin River water which must be conserved at Friant Dam on the upper San Joaquin River near Fresno.

From the Friant Reservoir irrigation water will be diverted northerly via the Madera Canal to thirsty lands of Madera County, and southerly via the Friant-Kern Canal to parts of Fresno, Tulare, Kings and Kern Counties which now are threatened with agricultural retrogression because of an acute irrigation shortage.

ARC WELDING AWARDS

Thirty-three Californians, twenty of whom are in the Southern section of the State, and twelve other Pacific Coast competitors, shared in the 382 awards made by the jury in the \$200,000 award program sponsored by the James F. Lincoln Arc Welding Foundation. Several thousand papers were submitted describing technical progress in welding and possible extension of its application in construction and other industries. From estimates of savings claimed by authors of the winning papers the jury of award found that savings to industry by arc welding conservatively aggregate \$1,600,000,000.

Pitcher

**Improved
Disappearing Doors
Save 20% Space**

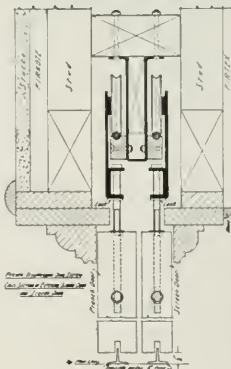

Joins with a 3 3/4" stud wall . . . steel studs . . . adjustable steel and wood track. Can be used for screen doors in connection with French doors. Send for detail drawing.

E. C. Pitcher Co.
461 Market Street
San Francisco

**Donovan Automatic
Awning Type
Windows**

Give 100% natural ventilation
and day-lighting control

•
**UNIVERSAL WINDOW
COMPANY**
Berkeley, California

**"AMERICAN MARSH"
Redi-Vac Vacuum
Heating Pump**

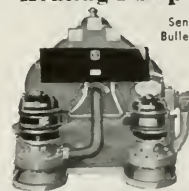

Send for
Bulletin 441

SIMONDS MACHINERY CO.
San Francisco 816 FOLSOM ST. Los Angeles 522 EAST 4TH ST.



SANTA MARIA INN

Santa Maria, California

*On the Coast Highway
between*

Los Angeles and San Francisco

OVER NIGHT

or

JUST A MEAL

FRANK J. MCCOY, *Owner*

Geo. A. Thompson, *Manager*

El Encanto Hotel

Santa Barbara

*On the Riviera, above the
Old Mission*

Frank J. McCoy, *Owner*

Fred F. Pimental, *Manager*

Independent Iron Works

Structural Steel
Ornamental Iron
Steel Service Stations
Steel Tanks
Standard Steel Mill Buildings
Bridges

821 Pine Street

Oakland

Clinton Construction Co. of California

*General
Contractors*

923 Folsom Street
San Francisco
SUtter 3440

The amounts of the individual awards ranged from \$101.75 for honorable mention to \$13,941.33 for the grand award. Recipients included engineers, designers, architects, production managers, superintendents, draftsmen, shop foremen, mechanics, inspectors, welding operators, welding supervisors, owners of businesses, college professors, high school instructors, students and others. Subjects of studies in the 44 divisions of the program, represented practically every product and structure of industry.

The grand award of the Foundation's program went to Mr. and Mrs. A. E. Gibson, president and stockholder, respectively, of the Wellman Engineering Company, Cleveland, Ohio. The authors jointly received \$13,941.33. Their paper is an outstanding treatise on all the elements required to assure the business and technical success of all users of welding throughout industry.

The Foundation's award program, which began 18 months ago, was judged by 31 engineering authorities from leading universities and colleges throughout the country, and has been hailed by leaders in science, education and industry as a valuable contribution to industrial progress in America.

J. O. Bishop, Torrance, master mechanic and welding supervisor, National Supply Co., received second award of \$2,747.39 for his paper on industry machinery, sub-classification K, functional machinery; while third award of \$1,526.33 went to Edmund G. Grant of California Institute of Technology, associate mechanical engineer and designer of project described.

Alfred Ernest Brattfisch, in charge of hydraulic design of hydro-power plants, with Los Angeles Department of Water and Power, won fourth award, \$203.51, in the division of containers, sub-classification H-2, "with contents moving."

Carl R. Jack, associate mechanical engineer of the U. S. Engineers Office, Los Angeles, drew fourth award, \$203.41, with his paper on functional machinery, sub-classification J-8, "not otherwise classified."

L. M. White of the Hollystone Com-

COMFORT

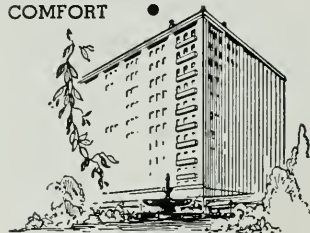

New

HOTEL CLARK

in Downtown

LOS ANGELES

Convenience is another offering of this hotel. Whether on business or pleasure bent, the Hotel Clark makes an ideal "base of operations," as well as a restful "billet" at the end of the day's "campaign." Good food, naturally. And moderate charges, as well as far room accommodations, give final significance to assuring ward — COMFORT

Single from \$2.50

Double from \$3.50

ROOMS
555
BATHS

Fifth and Hill

P. G. B. MORRIS, *Manager*

ANDERSON & RINGROSE

General Contractors

320 Market Street, San Francisco
Phone GARfield 2245

HIGH GRADE MILLWORK
AND INTERIOR FINISH
SASH AND DOORS

LANNOM BROS. MFG. CO.

FIFTH AND MAGNOLIA STREETS
OAKLAND, CALIFORNIA
Telephone: TEmplebar 3663

MULLEN MFG. COMPANY

BANK, STORE AND OFFICE
FIXTURES—CABINET WORK
OF GUARANTEED QUALITY
CHURCH SEATING

Office and Factory:
60-80 RAUSCH ST., Bet. 7th and 8th Sts.
San Francisco
Telephone UNDERhill 5815

G. P. W. JENSEN & SON

Building Construction

320 Market Street, San Francisco
Phone: GARfield 2444

DINWIDDIE CONSTRUCTION COMPANY • BUILDERS •

CROCKER BUILDING
SAN FRANCISCO

Carl T. Doell Co. *Plumbing Heating*

Plumbing Contractor
Veterans Memorial Building
Oakland

467 21ST STREET
OAKLAND
Telephone GLencourt 8246

pany, and C. W. Wells of the C. W. Wells Welding Works, North Hollywood, won fifth award, \$152.62, in the division of industry machinery, sub-classification K-10, "machine parts."

TWO NEW PAINTS

Two new paints of most unusual qualities have recently been added to the growing list of products manufactured by I. F. Laucks, Inc., Seattle, Wash.

The products—known by their trade names, Rezitex and Plasterex (for exteriors and interiors, respectively), are synthetic resin bound paste paints, and offer proven fire resistance as one of their most outstanding merits.

Both the exterior and interior product are said to effect beauty, protection and restoration all at the same time. Both may be applied to stucco, wood, metal, wallboard or fall kinds including plywood. Rezitex has been particularly recommended for use on certified exterior plywood. It has also been widely used for restoration work on old wooden and stucco buildings where the surface shows signs of deterioration.

Rezitex or Plasterex may be applied directly to any sealed surface, and may, if desired be textured to any desired pattern. It offers protection against moisture, sun, rain, vermin, as well as fire.

Both products may be applied with large wall brush or spray.

APPRENTICE TRAINING

A program of apprentice training, aimed at providing an adequate supply of the skilled workers required for the operation of its plants, has been inaugurated by the Tennessee Coal, Iron and Railroad company. The program consists of a four-year course and is designed to train young men as all-around skilled journeymen in their respective crafts. At the present time, approximately sixty apprentices are enrolled.

The instruction schedules cover 14 trades. The time of the apprentice is divided between the shop where he obtains practical experience, and the class room where he studies a course

Louis C. Dunn, Inc.

GENERAL
CONTRACTORS

Monadnock Building
San Francisco

Phone: DOuglas 4632

Empire Construction Co., Ltd.

Builders

RUSS BUILDING
SAN FRANCISCO
SUtter 2989

Smith

Lumber Company

WHOLESALE - JOBBING - RETAIL
FACTORY AND BUILDING LUMBER
PLYWOODS - ROOFING

DISTRIBUTING YARDS

San Francisco

Oakland

4th & Channel
MARket 0103

19th Ave. &
Estuary
FRuitvale 3174

YOUR INQUIRIES SOLICITED

JOSEPH MUSTO SONS-KEENAN COMPANY

MARBLE
and
ONYX

535 NORTH POINT STREET
SAN FRANCISCO
1801 S. SOTO STREET
LOS ANGELES

ABBOT A. HANKS, INC.
Engineers & Chemists

INSPECTING — TESTING — CONSULTING
CONCRETE • STEEL • MATERIALS
CHEMICAL AND TESTING
LABORATORIES
• RESEARCH AND INVESTIGATION •

TESTS OF STRUCTURAL MATERIALS
DESIGN OF CONCRETE MIXES
SHOP AND ERECTION INSPECTION OF
STRUCTURES AND EQUIPMENT
INVESTIGATION OF STRUCTURES
AND MATERIALS
TESTS AND INVESTIGATION OF
FOUNDATION SOILS
FIRE RESISTANCE AND INSULATION
TESTS

624 Sacramento Street, San Francisco

VAUGHN - G. E. WITT Co.

Manufacturers and Distributors

Pump Governors	Oil Heaters
Safety Pump Governors	Relief Valves
Automatic Gas Regulating Valves	Oil Burner Governors
Gas Burning Equipment	Oil Burners
Vacuum Pump Governors	Oil Pumping Sets
Vacuum Regulating Valves	Oil Valves
Continuous Flow Steam Traps	Oil and Steam Strainers
Thermostats	Duplex Oil Pumps
Reducing Valves	Rotary Oil Pumps
	Boiler Feed Pumps
	Water Heaters
	Boiler Feed-Water Regulators

4224-28 Hollis St., Emeryville, Oakland

Tenth Annual Party

OF
SAN FRANCISCO SECTION,
AMERICAN SOCIETY OF
CIVIL ENGINEERS

The Date, October 22, 1938
The Time, Dinner at 7 P. M.

AT
TREASURE ISLAND

Parallel lines may meet at infinity, but everything else in the world from now on is meeting at Treasure Island. At 7 P. M., October 22, 1938, the San Francisco Section of the American Society of Civil Engineers will pour sand in the slide rule of Fate and measure the dinner hour in side-real time.

There we will throw a logarithm on the fire and listen to the discourses of some of the greatest engineers and mathematicians of time. Which same may sound a little hard on Euclid, but as far as old Euclid is concerned, the men who built our great bridges are three theorems up on him. . . .

Two hundred and fifty-three years ago, on October 22, the Edict of Nantes was revoked. It's about time we promulgate another, based on permanent toleration. So, on that date, throw your Hoel and Johnson, your A. I. S. C., and other manuals out of the window, straddle a catenary and slide over to Treasure Island with us, where we will serve Newton's entire laboratory equipment in the form of appauce and otherwise ignore the laws of gravity.

RALPH A. TUDOR, Chairman.

Note: The island will be lighted until 7 P. M. Guests will be permitted to drive around between 6 and 7 P. M. All strains of engineers are welcome. Even architects.

related to his craft. Study courses cover such trades as mechanical drawing, mathematics, blue print reading and construction design. Shop work and related study work are coordinated so each will supplement the other.

Apprentices must be between 17 and 24 years when enrolled. They must be graduates of a high school or vocational school or must possess an equivalent educational background.

**THE
HERMANN SAFE CO.**

MANUFACTURERS AND DEALERS
OF
FIRE AND BURGLAR PROOF
SAFES AND VAULTS, SAFE-
DEPOSIT BOXES, ETC.

200 HOWARD STREET
SAN FRANCISCO
GARfield 3041 - 3042

Robert W. Hunt Company

ENGINEERS

Inspection - Tests - Consultation
Schools and Other Structures
Are Built as Designed

When Construction Materials are Inspected at point of Manufacture and during Erection by

ROBERT W. HUNT COMPANY

Cement, Concrete, Chemical, Metallurgical, X-Ray and Physical Laboratories

Chicago - New York - Pittsburgh
Los Angeles - All Large Cities
San Francisco, 251 Kearny Street

**FINE WATER COLORS
AND PAPERS
FOR ARCHITECTURAL
RENDERINGS**

**H. S. CROCKER
COMPANY, Inc.**

720 MISSION STREET
MARKET STREET AT SECOND
SAN FRANCISCO

Specify

CEMENTEX

for

Stucco and Concrete

Will water-proof and beautify!

FRANK W. DUNNE CO.

41st and Linden Oakland

**REPUBLIC STEEL
CORPORATION**



Manufacturers of

ENDURO Stainless Steel; TON-CAN Copper Molybdenum Iron Sheets and Pipe; and Steel Pipe, Sheets and Reinforcing Bar for every building purpose.

Write for information

Rialto Building, San Francisco, Calif.
Edison Building, Los Angeles, Calif.
White-Henry-Stuart Bldg., Seattle, Wash.

**JOHN
CASSARETTO**

—Since 1886—And Still Active—

Building Materials

READY MIX CONCRETE
ROCK - SAND - GRAVEL - LIME
CEMENT - PLASTER - MORTAR
METAL LATH - WOOD LATH
STUCCO - WIRE NETTING

Service Unexcelled

Bunkers

Sixth and Channel, San Francisco
Phones: GARfield 3176, GARfield 3177

**THE TORMEY
COMPANY**

**GENERAL PAINTERS
AND DECORATORS**

Phone UNderhill 1913

563 FULTON STREET
San Francisco

THE ARCHITECTURAL RECORD
PUBLISHED BY THE ARCHITECTURAL RECORD COMPANY

THE
ARCHITECT
AND
ENGINEER

NOVEMBER 1938

HAWS DRINKING FOUNTAINS MEET HEALTH REQUIREMENTS



HOLLYWOOD HIGH SCHOOL, HOLLYWOOD, CALIFORNIA
Marsh, Smith & Powell, Architects



This type of fountain installed in all Marsh, Smith & Powell schools

APPROVE • HAWS • DRINKING FOUNTAINS

HAWS DRINKING FAUCET CO.
Berkeley, Calif.

Dear Sirs:

"We have consistently specified Haws Drinking Fountains because they meet the requirements of the American Public Health Association, are good looking and dependable for long service and efficient operation."

MARSH, SMITH & POWELL
Los Angeles, October 17, 1938

These schools are equipped with
HAWS DRINKING FOUNTAINS

•
Hollywood High School

•
John Adams Jr. High School,
Santa Monica

•
Madison School,
Santa Monica

•
El Monte Union High School,
El Monte

•
McKinley School, Redlands

•
Goodwill Industries Bldg.,
Los Angeles

•
and many others

HAWS
Drinking Faucet Company
1808 Harmon Street, Berkeley, Calif.
Agents in San Francisco, Los Angeles, Portland, Seattle, Salt Lake City, etc.

The NOVEMBER 1938

ARCHITECT & ENGINEER

Fred W. Jones, Editor

Mark Daniels, A. I. A., Associate Editor

Edgar N. Kierulff, Assistant Editor

CONSULTING BOARD OF EDITORS

Architectural—

Arthur Brown, Jr.
Frederick H. Meyer
Timothy L. Pflueger
Will G. Corlett
Harry Michelsen
John J. Donovan
Lewis P. Hobart
David C. Allison
Gordon B. Kaufmann
Harris C. Allen
Glenn Stanton
Paul R. Hunter
C. H. Alden

Engineering—

H. J. Brunner
L. H. Nishkian
William Adrian
Wm. H. Popert
Homer N. Hadley
John J. Gould
Geo. E. Atkins

Advertising Manager—

J. Leslie Meek

Architects' Reports—

Vernon S. Yallop

THE ARCHITECT AND ENGINEER, INC., 68 Post Street, San Francisco, EXbrook 7182. President, K. P. Kierulff; vice-president, Frederick W. Jones; secretary, L. B. Penhollow. Los Angeles office, 832 W. Fifth Street. Published on the 12th on each month. Entered as second class matter, November 2, 1905, at the Postoffice at San Francisco, California, under the Act of March 3, 1897. Subscriptions, United States and Pan America, \$3.00 a year; Foreign countries, \$5.00 a year; single copy, \$.50.

Contents

FRONTISPIECE

Sierra Madre Elementary School	14
Marsh, Smith & Powell, Architects	

TEXT

Progress in School Design	15
Trends in Present Day School Design	23
Herbert F. Powell, Architect	
West Coast's First Large Housing Project	41
Jim Ferguson	
Making the Public Steel Minded	45
V. G. Iden	
A Street Plan For San Francisco	48
George S. Hill	
World's Fair Builders—Edw. L. Frick	50
Window Conditioning	51
Earl Aiken	
Court Ruling Affects Practice of Architecture in California	53
Architects' Bulletin	55

PLATES AND ILLUSTRATIONS

Schools by Marsh, Smith & Powell, Architects	15-36
Sunshine School, San Francisco	37-39
Martin Rist, Chas. Strothoff, Smith O'Brien and Albert Schroepfer, Architects	
Store For Gilbert's, Oakland	40
Frederick L. Confer, Architect	
San Gabriel Village Development	41-43
Edward L. Frick, a Portrait	50
Views of Double Glass Insulation	51-52

RUNNING FIRE

by
MARK DANIELS, A.I.A.

"Unfair"

For many years I have had a year to put in print just what I think of several persons in a number of stores and places, but the fear of some legal action has held my pen. Once or twice I have swung to the other extreme and written eulogies about men for whom I had an admiration, only to have them call me up and ask me not to make a fool of them. So it seems that we have less freedom of the press than we think. However, it appears that if you want to put accusations in print, you can do so if you will carry them on the end of a stick.

In the recent strike many pickets were carrying aloft a placard on which were printed the words, "This Store Is Unfair." I do not believe that any newspaper would be allowed to print on its pages the bald, lone statement that this or that store was unfair. But it now appears that if you want to make a statement of this sort about any institution, you can print it on a cardboard of any size you wish, just so long as you carry it and parade the streets, thereby demonstrating the fact that the grand old United States still permits freedom of speech, printed, written or spoken.

★ ★ ★

Connick's Blush

At a meeting of the Executive Committee of the Floricultural shows at the Exposition, the question of the naming of a new variety of rose was brought up. During the discussion, an account of an embarrassing situation in which Mr. Harry Connick's opinion as to a proper name for floral shows was reported. Mrs. Marie Kelly, in response to Miss Jean Boyd's remark of the incident, said that she thought it had given her an idea for the naming of the new rose.

It appears that they were not only talking of the naming of a floral show, but kidding Harry to some extent, and one or two comments were much to the point. The report developed further that on several occasions Harry's face got quite red. Mrs. Kelly then took the floor with these remarks, "It is very seldom that anyone has the privilege of seeing Mr. Connick's face red to any degree. It is also

true that this is a very rare and beautiful rose. I propose, therefore, that we name it 'Connick's Blush'."

★ ★ ★

It Can't Be Done

Early last month, Mr. Irving Morrow, consulting architect for the Golden Gate bridge and also architect for the Alameda-Contra Costa building and court for the California Commission at the Golden Gate International Exposition, came to my office a bit worried about the landscaping that was being done around his building. He said, "It appears, Mark, from your plans hanging in the corridors of the California Commission offices that you have used palms along the avenue on which my building fronts. I am quite exercised about this. Just what palms are they?" I told him that they were moderately sized *cocos plumosa* and explained that this type has a plume-like branch which is not stiff and as ungraceful as some other varieties. I further asked him what was making him worry about it and he replied, "I have an antipathy for palms, generally speaking. My objection to them is that when the wind blows they rattle and scrape together like pieces of sandpaper or similar substances and I have an objection to them principally for that reason."

I told Irving that I was sorry he had not seen the drawings before, that they had been hanging on the wall for two or three months and that now it was too late to change. The stock was ordered and paid for.

About a week later Mr. Harold Chambers, of the distinguished firm of Hunt & Chambers in Los Angeles, came into the office with an expression of elation and happiness that was in contrast to the one I remembered on the face of Irving Morrow. Harold immediately said, "Mark, I am very happy over the treatment of the landscaping in front of my building (the Southern Counties building, one of considerable size). I particularly like the way you have distributed *cocos plumosus* in a restrained manner along the facade." After a moment's pause, he continued, "Do you know, Mark, I think there is nothing so lovely as the rustle of palm leaves when the wind blows."

You can't please them all.

Labor Strikes in Agriculture

The other day Mr. Clark Kerr, in a lecture at the University of California, made an analysis of communist regulated strikes, with especial reference to San Joaquin Valley's cotton strike a few years ago. It seemed to be well planned and thought out, and the thirteen steps were as follows:

1. Make a survey of the community and contact small and large growers, trying to make friends and win the approval of a few owners. Always let local conditions establish the cause of the strike and the preliminary contacts.
2. Establish the thought that the organizers are friends of the workers. Call the strike when the owners need the labor the most.
3. Gradually organize small meetings unknown to the employers.
4. Call a wage conference and say that the owner who approved the strike, believes the wages demanded are all right. Be sure that the wage appears reasonable but be sure the employers won't accept it.
5. Organize a central strike committee and obtain leadership.
6. Organize auxiliary activities such as relief, articles and speeches.
7. Get the maximum number of people (children, women, etc.) associated and play labor against the growers.
8. Maintain a private headquarters where growers cannot break up meetings.
9. Prepare a talk about a defense system against vigilantes.
10. Watch very carefully the feelings of the workers.
11. Time the pamphlets and publications carefully. Do not demand too much and be sure the strike is lost.
12. Warn the laborers against growers' disguises in taking them back to work.
13. Bring various communistic groups to the approval of the workers.

Having gone this far, I am wondering what has been done to stop this campaign and what the devil are we going to do about it, if anything?



NEW TYPE OF CONCRETE HOUSE, ALAMEDA, CALIFORNIA
Frederick H. Slocombe, Architect

A DOUBLE WALL INSULATED CONCRETE HOUSE

A MODEL home, built along radically new lines, has recently been completed at Pearl Street and Otis Drive in Alameda by A. E. Troiel, inventor of "Steel Speedforms" and originator of insulated reinforced concrete walls.

The six-room, two-story house, designed by F. H. Slocombe, is unique in that it is constructed with two reinforced concrete walls, one inside the other, with insulating material between. It is claimed that this feature is proof against sudden temperature changes and any consequent "sweating" or moisture seepage.

The inside wall is built first and its outer surface

waterproofed with an asphalt compound. Insulating material one inch thick is then placed against the wall and again coated with waterproofing. The second wall is then poured around the first. Both inner and outer walls are four inches thick with one inch of insulating material and waterproofing in the center.

Door and window openings are made by locking up prepared trim molds with the wall forms. Metal plates with brass anchors are attached to the door forms to receive hinge screws. When the forms are removed the openings are ready for placing the doors and windows.

Partition walls, floors and roof are of reinforced con-

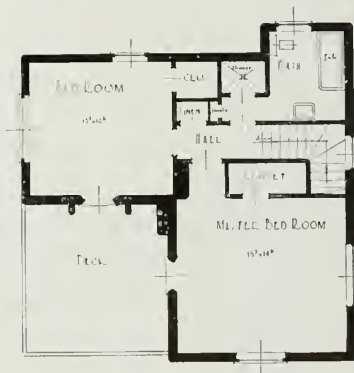
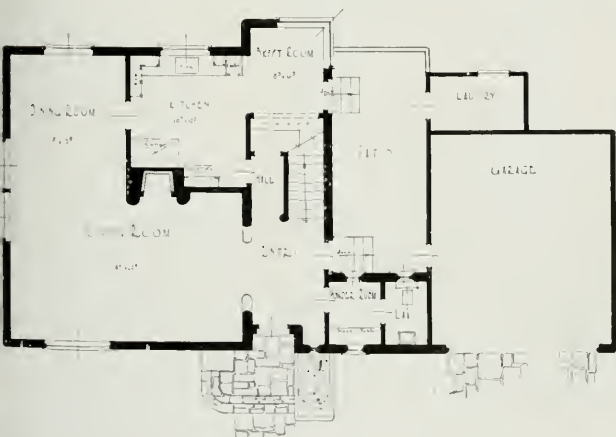



INTERIOR VIEW OF ALAMEDA CONCRETE HOUSE, showing trim and base moulds in cast concrete.

crete, giving the house great structural strength which eliminates settling and sagging. Floors are always level and doors cannot get out of line to sag or bind. Reinforced concrete is firesafe and impervious to termites and rot which assures practically absolute permanence.

Concrete on both outer and inner walls of the model home is finished with texture compound to harmonize with the modern architectural theme stressed throughout the entire dwelling.

Of particular interest to contractors is the fact that in constructing the house the steel forms were placed for an entire story, including closets and all other inside partitions. Steel reinforcing was then introduced in the forms and the entire story was poured in a single monolithic unit. From an engineering standpoint, the building may be compared to a thermos bottle with insulation ready to keep the inside at a uniform temperature regardless of heat or cold outside.

Although Mr. Troiel has built nine houses and forty garages with his patent Steel-Speed-Forms, the Alameda house is the first structure he has built with two concrete walls, one inside the other, with insulating material between. It is believed that this type of construction could be used to advantage for Federal slum clearance units where a duplication of a considerable number of buildings in one block is desirable.

Mr. Troiel's address is 2928 Ellis Street, Berkeley.



PLANT OF HELMS BAKERY CO.
CULVER CITY, CALIFORNIA

Immediate effective results, such as above, may be obtained for planting and landscaping your building projects. We maintain the largest selection of specimen plants in California, to suit every requirement and every quantity.

Call us . . . for beautiful trees and shrubs . . . to set off your finest buildings.

Roy F. Wilcox & Co.

WHOLESALE GROWERS

MONTEBELLO (LOS ANGELES COUNTY) CALIF.
65 RICE STREET SAN FRANCISCO



New!

A SILENCING UNIT FOR SLOAN FLUSH VALVES

● Now you may obtain *completely quiet* operation of the world's finest flush valves—not only on new work, but on old installations which have become noisy from years of use.

● *Any* installation of Sloan Royal, Star, Crown, or Naval Flush Valves may be transformed to the new *Quiet-Flush* by the replacement of the present stop valve and the insertion of a new guide and seat in the flush valve. This easily accomplished change reduces flush valve noises to the faintest murmur. Sloan-equipped hospitals, hotels, apartments, offices or schools desiring noise abatement now have an economical solution to this problem.

● On new installations *Quiet-Flush* may be specified in all the styles and variations of the Royal, Star, Crown and Naval Valves.

● Sloan *Quiet-Flush* equipment is unlike any silencing device previously obtainable. It combines the best features of generally known methods with important contributions from Sloan research. Sloan value and efficiency are your assurance of the utmost in flush valves—*plus* utter quiet.

SLOAN VALVE CO.



CHICAGO, ILL.

HOW'S YOUR LAWN?

By BERNIECE ASHDOWN

NO other single factor is of so much importance to the appearance of a house or garden as is its lawn. A healthy, well maintained greensward infinitely enriches the home's appearance and enhances its value, while a poor, sickly, thin lawn makes the whole place seem run down and neglected.

Unlike Topsy, beautiful lawns don't "just happen"; they are the result of careful planning and hard work.

A little foresight at the outset will prevent many problems which must be met by the owners of lawns which are less carefully planted. The possessor of a properly planted and maintained lawn need never look forward to the expense and trouble of having the work done over. His lawn will become richer and lovelier throughout the years.

The best time to plant a lawn is after the spring rains. They can, however, be started in the late summer and be kept well mulched during the wet winter season.

Care in the execution of the preliminary work is of utmost importance. It must, of course, vary with the type of soil and location. If the soil is clay or heavy adobe it is necessary to make trenches two-foot deep and lay tiles for drainage. Light and well drained soils do not require this treatment. If the soil is sandy, it should be removed to the depth of one foot and replaced with good loam. Cultivation can not be stressed too much. The whole lawn area should be thoroughly turned over and allowed to remain in this rough state until it is completely dry and warmed by the sun. Then it may be generously fertilized with peat moss, well rotted stable manure or a good commercial fertilizer. The soil should be thoroughly broken up and graded, shaped, raked smooth, rolled with a light roller and then raked again. If there is time, it is advisable to let the first crop of weeds germinate and then on a warm dry day hoe them out. Be careful not to disturb the soil surface any more than necessary.

Lawns may be made by laying turf, but while it gives an immediate effect it is very expensive.

Seed should be sown evenly over the surface of the ground, using a rotary motion of the forearm. A day should be chosen when there is absolutely no wind, otherwise the seed will not be distributed evenly. It should then be raked lightly—just enough to cover the seeds: about one-quarter of an inch deep for Kentucky blue grass and a little more for other kinds.

Water should not be applied to the lawn until the seed has been in the ground at least two days. Using a fine misty spray to avoid washing, it should then be given a thorough soaking and kept moist until the grass is two inches high. Thereafter it may be watered two or three times a week. At

all stage it should be gone over again with a light roller and cut. Adjust the mower to its highest point and be careful to choose a time when the ground is not too wet.

There are several excellent kinds of lawn grass. Much is said in favor of mixing seed but I think it is safer to use it unmixed. In any case, buy the best quality. Cheap seed is poor economy. Kentucky blue grass is considered to be the best all around grass for lawns and is especially adapted to soils containing lime. It should be planted at the rate of one pound of seed to one hundred and fifty square feet of lawn.

English and Australian rye grass is rougher in texture but an excellent mixture for quick lawns.

Bermuda grass is sometimes used but it is very wiry and turns brown in winter.

Clover requires more water than most grass and is not as even in texture.

For acid soils Cocos and Astoria Bent make excellent lawns. Their seed may be sown at the rate of one pound to two hundred and fifty square feet.

In seaside locations Sea Bent is splendid. It will grow in the sand and is a wonderful sand binder.

Under ordinary circumstances, the lawn should be cut once a week. If it is cut frequently, the cuttings may be left on the lawn, thus providing the grass with a good mulch and keeping it spongy. Cutting will eradicate most weeds but those with perennial roots must be pulled out. Special attention should be given to eliminate dandelions. They should be cut out immediately; in no case should the seed be allowed to ripen or in a short time the lawn will be completely ruined.

The amount of water required by lawns depends upon the weather and soil. A sprinkling system solves many of the vexing problems of maintaining lawns.

Rolling should be repeated at intervals. It keeps the surface even and smooth.

When parts of the lawn become worn or uneven it is very simply corrected by cutting the sods in one foot squares, removing them, filling in and enriching the sub-soil with fertilizer and then replacing the sod squares. Then they should be tamped even with the rest of the lawn.

IMPROVES WITH AGE

Dear Editor:

You have been sending me the A. and E. for a long time—out of kindness of the heart—and my conscience has burned because I know and appreciate its worth. I want you to have my great thanks for your kindness as you have my high regard for the splendid job you're doing. I feel that The Architect and Engineer improves, like good whiskey, with age. Success and good luck.

Sincerely,

HAROLD W. DOTY, Architect.
Portland, Oregon.

*A few hours
a few dollars*

AND

Sealcon

WILL MAKE YOUR
BASEMENT

DRY

SEALCON forms a water-resisting seal for basement walls and floors, brick, stucco or any other masonry. Just paint it on, inside or outside, to any wet or dry surface. One coat gives lasting protection . . .

conquers dampness and seeping water. A perfect base, or mixture, for oil paint.

EASIER
TO APPLY
THAN PAINT



ASK DEALER
LISTED
BELOW
ABOUT

Sealcon

GUNN, CARLE & CO.

Distributors

20 Potrero Ave. UNderhill 5492
SAN FRANCISCO

1938



**BUY CHRISTMAS SEALS
PROTECT YOUR HOME
FROM TUBERCULOSIS**

600 Visitors A Week

...And One Thing They Always Notice
Is The Clean Hard Maple Floors!

*Writes Mr. E. F. DAVIDSON, President,
Davidson Baking Co., Portland, Oregon*



Mr. Davidson says:
"Hard Maple is by far the most economical floor to service and keep in good appearance... About 120 women visit our bakery every day and one thing they always notice is the hardwood floor. They know that hardwood floors in a home are the very best, and they realize the Hard Maple floor means we take pride in our bakery."



MFMA Northern Hard Maple floor in The Davidson Baking Company, Portland, Oregon

BAKERY floors are bought for cleanliness and economy—not for advertising value. But when you pick *Northern Hard Maple*, you get both.

For Hard Maple's smooth surface holds no dust, offers *natural* sanitation. To visitors, its spic-and-span appearance plainly says, "This plant is *clean!*" Employees, too, appreciate Maple. Warm, dry, easy to work on, it reduces fatigue, increases efficiency.

And for economy, Hard Maple has no equal. Like bakeries, countless factories have proved its remarkable resistance to abrasion and indentation; it does not sliver, splinter, or develop ridges through the years. Hard Maple creates no dust, simplifies alterations, anchors machinery firmly—is simple and inexpensive to maintain—and, properly finished, is cleaned by brushing alone.

Before building or remodeling, investigate this most-logical service flooring. And when you buy, be sure it's **MFMA*** Northern Hard Maple (the Association-guaranteed Maple)—available in strips or blocks.

MAPLE FLOORING MANUFACTURERS ASSOCIATION

1786 McCormick Building, Chicago, Illinois

*See our catalog data in Sweet's, Sec. 11/76.
Write for folder describing good service finishes for old or new Hard Maple floors.*

**To be sure of Association guaranteed grading, specify and look for the MFMA trademark (indented and stamped). The following manufacturers are licensed to use it:*

- Beck, August C. Co., Milwaukee, Wis.
- Brown Dimension Co., Manistique, Mich.
- Bruce, E. L. Co., Memphis, Tenn.
- Mill at Reed City, Mich.
- Conner Lumber & Land Co., Laona, Wis.
- (Sales Office, Marshfield, Wis.)
- Farrin Lumber Co., M. B., Cincinnati, O.
- Holt Hardwood Co., Oconto, Wis.
- Kerry & Hanson Flooring Co., Grayling, Mich.
- Kneeland-Bigelow Co., Bay City, Mich.
- Kneeland-McLurg Flooring Co., Phillips, Wis.
- North Branch Flooring Co., Chicago, Ill.
- Oval Wood Dish Corp., Tupper Lake, N. Y.
- Robbins Flooring Co., Rhineland, Wis.
- Stephenson Company, L., Wells, Mich.
- Wells, J. W. Lumber Co., Menominee, Mich.
- Wisconsin Land & Lbr. Co., Hermansville, Mich.
- Yawkey-Bissell Lumber Co., White Lake, Wis.

Floor with **MFMA Maple**
(NORTHERN HARD)



SIERRA MADRE ELEMENTARY SCHOOL, SIERRA MADRE, CALIFORNIA
MARSH, SMITH & POWELL, ARCHITECTS

Sierra Madre is "ourville" to Los Angeles Times columnist, Lee Shippey. Its only school was built in 1930 at a construction cost of \$165,000, replacing an old wooden building of the 19th century . . . the sloping site is almost a full story higher on the west end of the building than the east and this difference in elevation is taken up entirely by easy ramps in the corridors . . . the building is of reinforced concrete with the form marks only slightly covered with a stucco dash coat.



FRONT VIEW OF SIERRA MADRE SCHOOL

THE lighting fixtures throughout the building were designed in the architect's office. The kindergarten fixtures each have an encircling band on which parade many animals—lions, rhinos, camels, even a boa constrictor.

PROGRESS IN SCHOOL DESIGN

AS EVIDENCED by the Work of Marsh, Smith & Powell, Architects

THIS is a progressive Nation. It is young and unafraid. Its people will risk experimentation in the search for material and physical improvements and for anticipated cultural values. Evidence of this is continuous—more so in the trials and balances of education than perhaps in any other of its numerous activities. The progress of American education in the last fifty to seventy-five years is marvelous. The history of American education is an epic as intriguing as it is interesting; its reading is very much worth while.

To the credit of the architectural profession, the architecture of educational buildings has kept abreast with the progress of education. In fact, more often than otherwise, the architect has led the way in the solution of problems which have opened avenues of thought leading to further developments in advancing the training and welfare of the child, the pupil and the student.

The architects of California can well take pride in that which has been accomplished during the last twenty-five years. Their school buildings are beautiful—they are practical, they are utilitarian, and they are economical in cost and in administration. Their achievements reflect the spiritual values of the people. It is indeed a pleasure to pay tribute to the firm whose work is featured within the covers of this issue, for it has contributed greatly to the excellent school buildings in California—J. J. D.

SOUTH PASADENA HIGH SCHOOL—MAIN ENTRANCE TO AUDITORIUM



THE Auditorium, designed by Messrs. Marsh, Smith & Powell, has three 8'-0" high waste mold panels executed by Merrell Gage, and symbolizing the activities of the assembly hall . . . are colored a light warm gray with a deep gray tan background . . . the organ grilles have been designed to enhance the proscenium opening . . . the interior of the Auditorium is most colorful with a carefully studied balancing of gray greens, terra cottas, plums, dusty blue, mustard, and coral, with large wall areas a neutral buff.

SOUTH PASADENA HIGH SCHOOL—SHOP BUILDING



THE South Pasadena High School building program, since the 1933 earthquake, has included two practically symmetrical one-story wings in front of the old Administration Building and the erection of a new Shop and the extensive rehabilitation of the old Auditorium.



FINE ARTS BUILDING



PATIO, SOUTH PASADENA HIGH SCHOOL

SOUTH PASADENA HIGH SCHOOL — SCIENCE UNIT



SOUTH PASADENA HIGH SCHOOL—ENTRANCE TO SCIENCE BUILDING

LABORATORY and special class rooms occupy the new units. One story California type of building with outdoor communicating corridors has replaced former two-story brick buildings of the closed type of design. Corridor floors are acid stained in russet browns and greens. Ceilings are of fibreboard with unusual patterns. Art room ceilings are largely of glass, walls are of alternate panels of fibreboard and cork board separated by polished chromium metal strips.

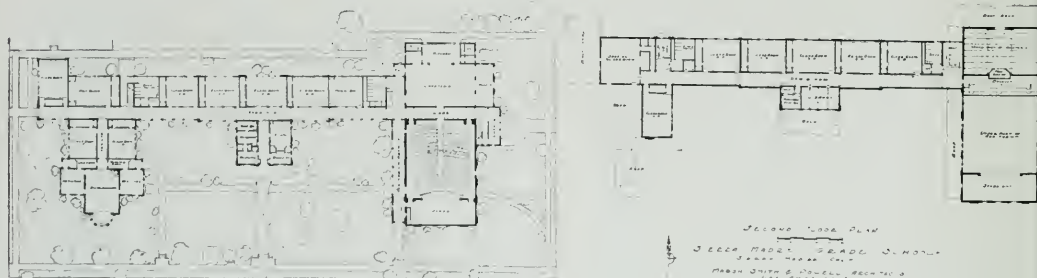

PLANS, SIERRA MADRE GRADE SCHOOL, SIERRA MADRE, CALIFORNIA
See Pages 14-15

SOUTH PASADENA HIGH SCHOOL—ENTRANCE AND TOWER



THE picture shows the main building of an interesting educational group which Marsh, Smith & Powell have built at a cost of \$410,000. The structure is of reinforced concrete, style "California Romanesque," with an unusual use of tapestry brick inserts and panels in the concrete.

SOUTH PASADENA HIGH SCHOOL—FRESCOES BY MILLARD SHEETS



Photo by Eaton

THIS building has been the object of some very interesting decorative treatment. On the north exterior wall of the auditorium are three excellent frescoes executed by Millard Sheets. They represent, from left to right, California's agriculture, commerce and industry.

SOUTH PASADENA HIGH SCHOOL — FRESCOES BY STUDENTS



Millwork by Graves

Photo by Eaton

STIMULATED by the Millard Sheets frescoes in the patio, the Junior High School students executed a group of three early California history subjects in the cloister arcade on the south side of the Auditorium.

HOLLYWOOD HIGH SCHOOL—STAIR HALL



CONCRETE GRILLE WHICH LIGHTS THE MAIN STAIR HALL OF
HOLLYWOOD HIGH SCHOOL
MARSH, SMITH & POWELL, ARCHITECTS

TRENDS IN PRESENT DAY SCHOOL DESIGN

By HERBERT J. POWELL, Architect

It cannot be pointed out too often that school design in California received a great development as a result of the Long Beach earthquake. Previously, design, like medieval philosophy, had become solidified. Just as the churchmen of the 10th century were expending great amounts of energy on non-consequential details, while the main lines of thought had become stagnant, so in the twenties, too much thought was being put on such questions as how much and what kind of glass if any, should be used in corridor doors and how many ribs should be detailed in the bottom of a black-board chalk trough.

Like water impounded behind a dam, the widespread construction program following 1933, released a flood of ideas, many of them good, and the design of schools in California became a matter of adapting the building to the educational program, instead of adapting the educational program to a bunch of new schools that were designed from "the standards," which are labor and thought-saving devices for perpetuating the status quo.

In no area of school house design has this new approach been more apparent than in the elementary school. When John Dewey pointed out that a child who has the opportunity only to listen to and read about activities might not develop as fully and significantly as one who also participates in the activities he reads about, an idea was released which, to my mind, has a profound bearing on elementary school design.

Anyone who has seen teachers trying to teach by projects in a traditional type of classroom knows how they are hampered. The Dutch house that is too big to go between the door and the radiator, the piles of boards stacked in the rear of the room because there is no place for them—the large sheets of cardboard lean-

ing at the side of the teacher's desk because the one case in the room is only big enough for small books—the elementary classroom was badly in need of re-thinking and, in the last analysis, it was really the architect's job to do it.

It would appear that the activities of an elementary classroom could be simplified to the following grouping:

(a) CLASSROOM AREA

Activities using a classroom as it has always been used, such as drilling, question and response, visual education—where the pupils sit in a more or less compact group.

(b) READING AREA OR LIBRARY USE

Where some pupils may pursue some subject a little further than the rest.

(c) CONSTRUCTION AREA

or alcove where the training in using eye and hand is motivated by an interest started and carried over from (a) or (b).

(d) CONTROLLED RECREATIONAL AREA

such as an out-door terrace where supervised periods of relaxation may occur.

(e) SPECIAL SKILLS AREA

where art may be taught and where in the case of the ground adjacent to the outdoor terraces, even the simple rudiments of gardening may be learned.

The modern elementary school should provide for this kind of teaching. The architect should cooperate with the teachers and administrators and school boards in helping to bring this about.

In considering the junior high school and more especially the high school, the problem changes. These buildings are usually two stories or more in height. Larger groups of students are collected on a single site. The activities become specialized. Instead of the broad groups of skills and branches of learning being



LYNWOOD JUNIOR HIGH SCHOOL, LYNWOOD, CALIFORNIA
Marsh, Smith & Powell, Architects

taught in one room, specialized rooms are provided for the different courses.

Here the problem is one of relationship of one department to another. It is more complex, and usually calls for analysis of the local situation for solution. One school may need large shops, domestic science department and gymnasiums, while the nature of another community demands emphasis on the dramatic and art departments and English courses. Therefore, any generalization on high school layouts is without much value.

However, in the individual departments, considerable progress in planning is being made. The art department in South Pasadena High School is a case in point. Instead of a traditional room 23 feet wide with a work room at the end, there are a group of three rooms, arranged around a patio. Instead of wide side windows only, each of these art rooms is lighted in addition by single ceiling or skylights, two-thirds the size of the room. The casework, sinks,

display cases, etc., were given special thought. The weaving room attempts to indicate "Weaving" in its ceiling design—the rooms in general are more like studios than classrooms in their atmosphere.

A final word as to architectural style. A change has been taking place in the architectural designs here in Southern California. Even the most casual layman is aware of this. While it can be demonstrated that beautiful and aesthetically satisfying designs can be and have been executed in the manner of the great architectural styles of the past, architects of Southern California are increasingly approaching the problem of design from the point of view of the twentieth century American.

In the next twenty-five years, modern architecture should develop from the tentative, sometimes dull, nevertheless promising type of design, to a style which may truly express our age as did the great styles of the past truly express those ages.

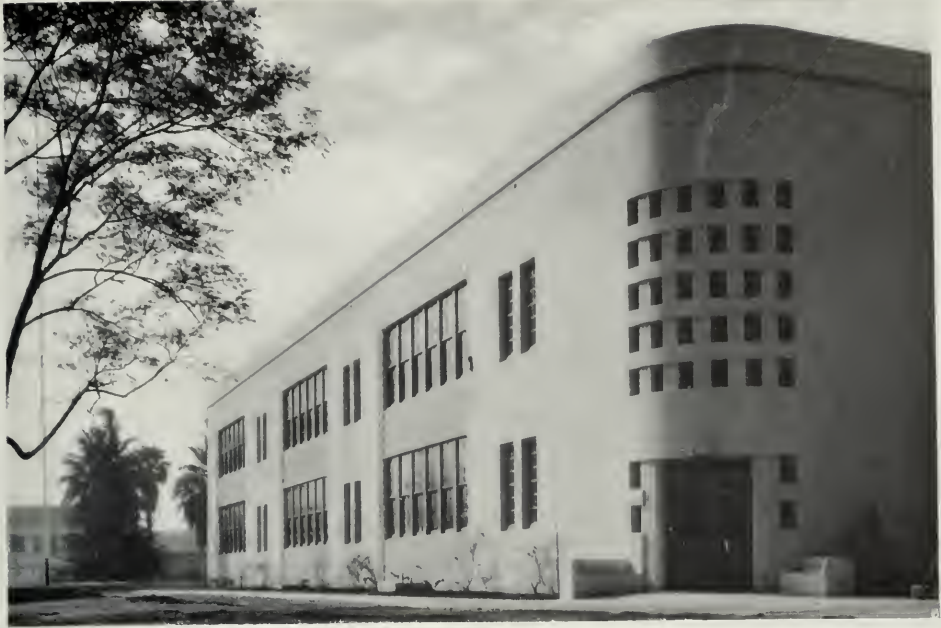

HOLLYWOOD HIGH SCHOOL—HIGHLAND AVENUE FRONT
 Marsh, Smith & Powell, Architects

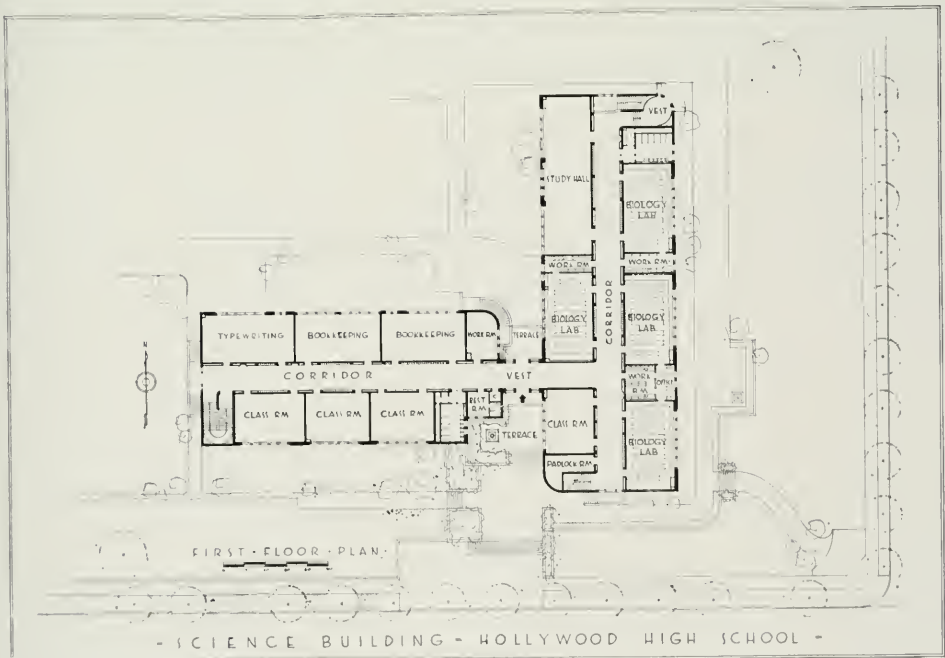

HOLLYWOOD HIGH SCHOOL—MAIN ENTRANCE



Photo by Eaton

THE design of the building may be called modern classic, for although classic cornices and molds are missing, the window grouping of the class rooms is vertical.

THE construction of reinforced concrete features over the entrance a waste mold by B. Mako representing science through the ages. In the fore-court is a cylindrical pylon by Merrell Gage furnished to the school as a Federal Art project. This depicts scholastic activities.

HOLLYWOOD HIGH SCHOOL—STAIR ELEMENT



Millwork by Graves

Photo by Eaton

THE great concrete grille in the front which lights the stair hall has its open panels filled with leaded flint glass; an amusing detail is the "battle" between curved lines at the bottom and straight lines, which finally win out at the top of the grille. (See also detail on page 22.)

A recently constructed Household and Liberal Arts Building balances this Science Building on Sunset Boulevard.

NEWPORT HARBOR UNION HIGH SCHOOL — GENERAL VIEW



Photo by Eaton

THIS building occupies a picturesque site on the bluff overlooking Newport and Balboa in Orange County, California.

BUILT from a bond issue of \$350,000, the main building cost \$260,000 and is of reinforced concrete. The center lines of the corridors, which give circulation around the patio, form a perfect square.

THE tower, visible for many leagues at sea, and a landmark on marine charts, serves as a visible evidence of their school to the residents of Newport and Balboa, although the main building is hidden from sight.

NEWPORT HARBOR UNION HIGH SCHOOL — GYMNASIUM



FLOWERS AND SHRUBS LEND BEAUTY AND CHARM TO THE PLAIN, MODERNISTIC LINES OF THIS BUILDING

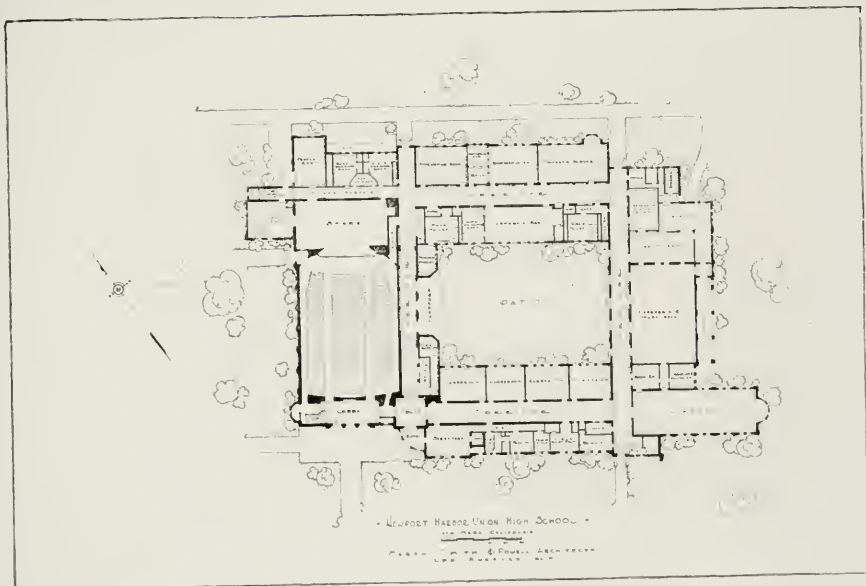

NEWPORT HARBOR UNION HIGH SCHOOL



A USEFUL COMBINATION OF CAFETERIA AND STUDY HALL (SEE PLANS)

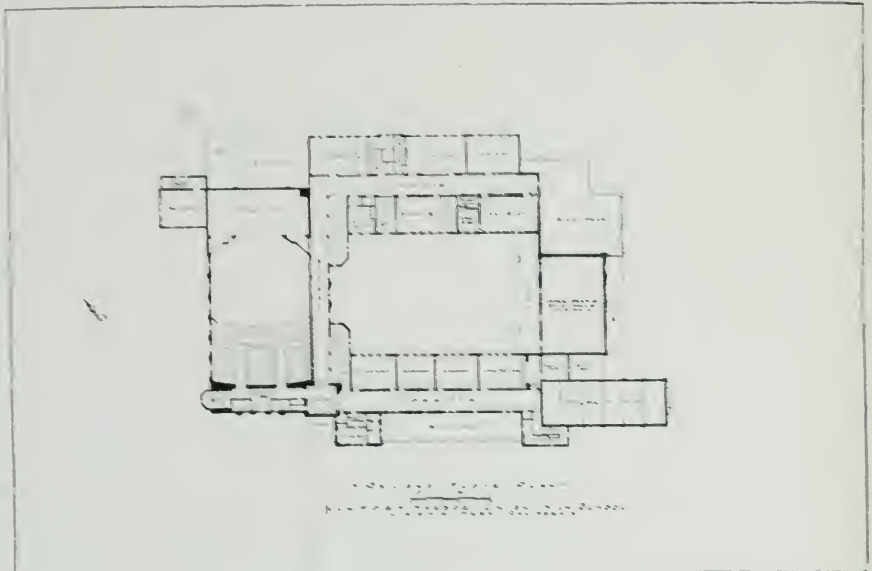

NEWPORT HARBOR UNION HIGH SCHOOL—PATIO SHOWING TOWER



Photo by Eaton

HERE is a free interpretation of Lombard Gothic. Ornament is cast monolithically in the concrete. The forms and silhouettes are simple and elemental; count easily at distances.

THE inner court may be used for any special outdoor festivals, a platform at the west end being formed by the flanking ramp towers, which ramps take most of the student traffic from first to second floor.

HENRY E. HUNTINGTON SCHOOL, SAN MARINO — OPEN AIR STAGE



Photo by Eaton

Millwork by Graves

THIS interesting school has been under construction for many years, and several architects have had a part in its design. The older tile constructed portion was rehabilitated in 1936 by Marsh, Smith and Powell.

AT that time the outgrown Auditorium was removed and where the stage had been this outdoor theater was built, using the broad patio for audience seating requirements. The stage is also on the center axis of the school and as one passes the Administrative Offices it is framed by a large arch.

HENRY E. HUNTINGTON SCHOOL, SAN MARINO — GYMNASIUM



Photo by Eaton

THE Gymnasium unit is more than an athletic center. The school social life centers around it. Dances are held here; a lounge annex was built and is used by the P.T.A., together with its kitchenette. Manual Training and Domestic Science rooms form a patio at the west end of the building.

JOHN ADAMS JUNIOR HIGH SCHOOL, SANTA MONICA — FRONT



Photo by Elvira

A modern one-story solution, typically Californian with its patios and courts, and its open-air communicating corridors and shelters.

JOHN ADAMS JUNIOR HIGH SCHOOL, SANTA MONICA — PATIO



Photo by Fusion

VIEW ACROSS FORMAL GARDEN IN FRONT OF LIBRARY
Marsh, Smith & Powell, Architects



MADISON SCHOOL, SANTA MONICA, CALIFORNIA

A two-story masonry type building built prior to 1933; reconstructed as two-story, with gunited structural walls, 'quake and fire resisting.



IVY AVENUE SCHOOL, MONROVIA, CALIFORNIA

Originally a two-story brick school, rehabilitation converted it to a one-story wood frame—a frequently used solution to the earthquake reconstruction problem. Unusual and attractive colors feature this school.



Photo by Moulton

Patio of the San Francisco Sunshine School showing the graceful arches, broad balcony and sturdy buttresses as well as the decorative features of the court. Landscaped plots of flowers, window grilles and a flag-staff pedestal decorated with colorful Kraftile of Spanish theme all add attractive details of decoration to the broad sweep of architectural design.

A SCHOOL FOR THE PHYSICALLY HANDICAPPED

ONE of the most unique school buildings in San Francisco—not only for plan and elevation but for its purposeful use—is the Sunshine School facing east on Bryant Street and west on Florida Street, covering an area of 250 square feet, forming a "U" shaped building with a patio facing south.

The entire structure is reinforced concrete, all exposed walls showing the lines of the form lumber. The use of waste molds plays an important part in the design of the exterior.

The ceilings are exposed concrete joists—built with wood forms. These joists are decorated in color of Spanish design and simulate wooden beams. The under side of the ceiling slabs between the concrete joists are covered with random width acoustical boarding.



LOBBY AND STAIR HALL

SUNSHINE SCHOOL, SAN FRANCISCO, FOR PHYSICALLY HANDICAPPED



Photo by Moulin

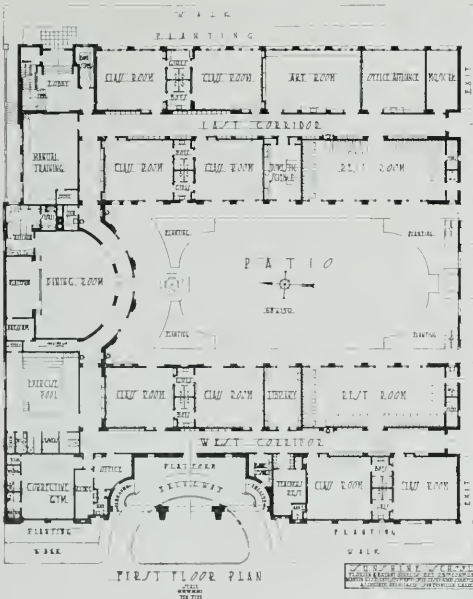

In the Spanish manner, from curving driveway to bright coloring on exposed beams, details of this housed entrance at Sunshine School combine to give an effect of brightness and beauty. Color and shimmer are attained in the brightly glazed Spanish decorative Kraf-tile employed as wainscoting and extended to the Iberian convention trim of doors and windows. The generous use of the decorative tile adds color in profusion as well as provides a cheerful reflected light.

The Sunshine School is a unit of the public schools system of San Francisco. Its predecessors were the Buena Vista Health School and the Sunshine School for orthopedic cases. The latter was initiated in 1924 by the San Francisco Rotary Club.

Special facilities for the physically handicapped children and those inclined toward ill-health are provided. The interior plan was recommended by a special committee of physicians and educators and approved by the San Francisco Board of Education.



One of the interesting features of the equipment of the Sunshine School is the therapeutic bathing pool, immaculately sanitary, colorfully attractive. This pool of fresh water is set above the floor level, to facilitate the handling of the physically handicapped pupils. A mosaic is used for capping and the 6 x 9 Master Kraftile to face and line the pool.

Photo by Maulin

Resourcefulness of the architectural designers is apparent in that the problems and requirements recommended by the special medical committee were met expertly both in plan and exterior beauty. Generous use of tiled surfaces assured ease of cleaning as well as cheerful color. The hand-finished Spanish decorative tile created for the exterior by C. W. Kraft of Kraftile Company, as conceived by the architects, Martin Rist, Charles Strothoff, Smith O'Brien and Albert Schroepfer, is especially noteworthy for its contribution of brilliance to the attractively colorful effect.

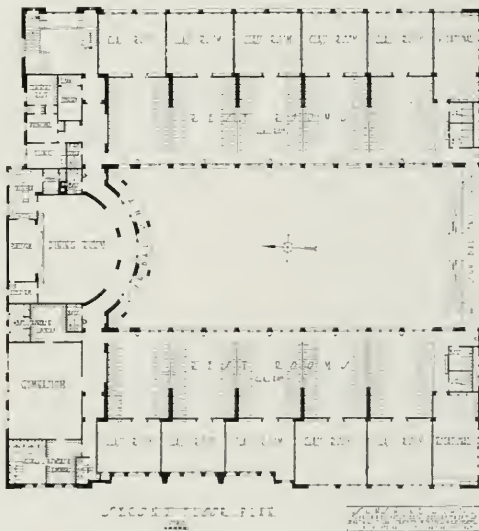



STORE FOR GILBERD'S, OAKLAND, CALIFORNIA
FREDERICK W. CONFER, ARCHITECT



SAN GABRIEL VILLAGE DEVELOPMENT, SOUTHERN CALIFORNIA
This First Unit of 50 Houses Recently Completed Will Be Followed by
800 More

WEST COAST'S FIRST LARGE HOUSING PROJECT

By JIM FERGUSON

THE San Gabriel Village development, started in July on Del Mar Avenue in east San Gabriel, is described as "the West's first large scale housing project." Here, for the first time, on the West Coast at least, mass production methods are being applied to home building. The plan calls for the erection of "a completely self-contained community," consisting of approximately 840 two- and three-bedroom single family dwellings, and for the construction of a shopping center to serve the community.

By the purchase of land and materials on a quantity basis, and by building the houses in units of 50 at a time, the development is able to produce a well-constructed, individually designed small home at a price from \$1,000 to \$1,500 less than homes of similar size and design built under usual conditions. These homes

sell from \$3,666 to \$4,225, financed through FHA. Percy Bilton, Ltd., an English firm which has completed a number of similar developments in and around London, is financing and promoting the enterprise.

This firm, headed by Percy Bilton, who organized it in London some fifteen years ago, has financed and constructed over 2,600 homes in England. In the famous Perivale Estate in the suburbs of London, the company built a complete village which included 70 factories as well as 1,500 homes and a central shopping district. The Sutton Estate in Surrey, made up of 850 homes, and the Greystoke Estate in London, made up of 800 homes and four blocks of flats, are two other successful large scale housing developments completed by this firm. At present they are developing two estates in Middlesex, England.

Bilton became interested in the housing problem in Southern California during a winter spent here three years ago. The need for low-cost dwellings, and the availability of Federal credit, convinced him that an undertaking similar to his English projects would be success-

ful. The shopping center will be erected on the main cross street. All parkings will be planted to lawn, and the grounds around the houses will be landscaped prior to sale. Street paving and sanitary facilities will be installed and included in the price of the house.

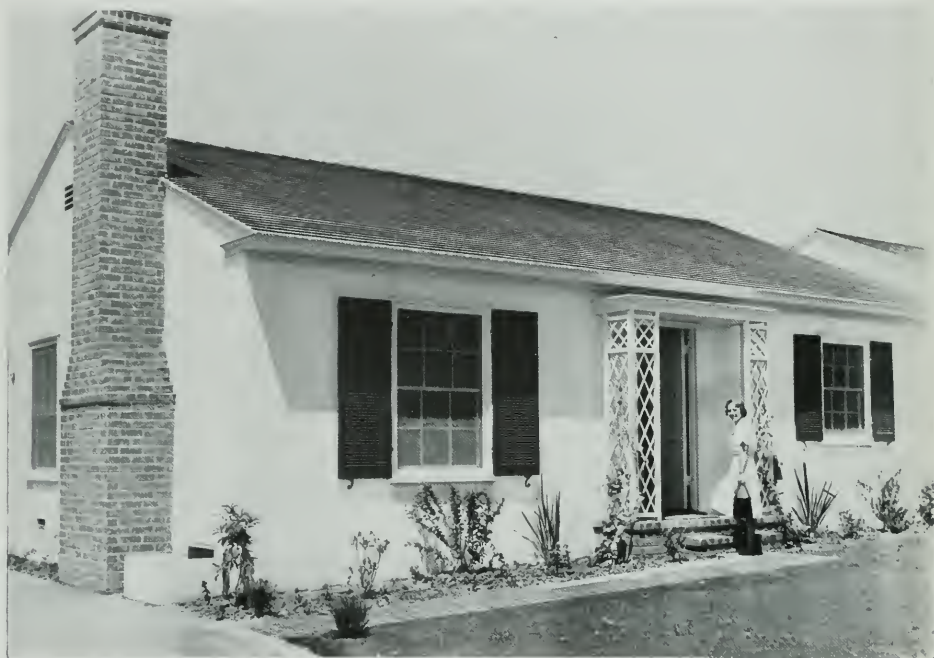

SAN GABRIEL VILLAGE DEVELOPMENT IN SOUTHERN CALIFORNIA
"Type 3" House containing three bedrooms, a living room, kitchen and dining room.

ful here. During three successive winters he canvassed possible sites, comparing locations for accessibility to metropolitan centers, desirability of environment, excellence of schools, fire and police protection, and finally purchased 160 acres on Del Mar Avenue in San Gabriel. The site was that of an old airport, and a hangar was still standing. This is in use as a shop for fabrication. An option on additional acreage was also taken.

The development is laid out with one wide cross street running from east to west. Lateral streets radiate from this main street, laid out in such a way that there will be no through

The houses are of three classes or types. The first, designated by the firm as "Type 2," consists of two bedrooms, a living room, dining room and kitchen. "Type 3" and "Type J" contain three bedrooms, a living room, kitchen and dining room. Each home is individually designed, and although they are uniform in size, variation is accomplished by different arrangements of the rooms and elevations.

Bilton did not attempt to import from England the same plans and specifications used there. He studied the climatic requirements and style preferences of Southern California, and allowed himself to be guided by the coun-

sel of leading Southern California housing authorities. His English homes are constructed mainly of brick. The homes in the San Gabriel Village development are frame dwellings, finished either in stucco or boards.

All the homes have hardwood floors throughout. The plumbing fixtures, doors and windows are standard, but hardware and lighting fixtures vary from house to house. The "Type 3" and "Type J" houses have fireplaces in the living rooms. These fireplaces are piped for gas fuel. A dual gas floor furnace and an automatic gas water heating system are standard in all houses, and gas connections are supplied for cooking and refrigeration. Automatic convenience and low cost of natural gas dictated its selection for all cooking, heating and refrigeration.

Mass production is achieved by having the studding and flooring constructed in a shop on the subdivision. The foundation is laid by the foundation crew. As soon as the concrete is set, another crew transports the frame in sections from the factory. The floor joists and sub-floor are laid and the studding set in place. In this manner the complete framework of the house can be set up within a few hours. The houses are erected in units of fifty.

During construction there are three FHA inspections, in addition to the regular inspections by city officials. Every home is constructed to FHA specifications, rigid as to material and methods of construction.

The shopping center will be non-competitive and will have every service necessary to make the village self-contained. These buildings will be owned by the Bilton Company permanently and leased to the operators.

Bilton secured an option on the property in April, 1938. The first house was started on June 4 and completed on July 19. The public was invited to inspect this on that day. Since then it is estimated that fully 60,000 people have visited the project. Between 3,000 and 3,500 people go through the development every Sunday.

The Bilton Company, if plans proceed according to expectations, hopes to have 250



SAN GABRIEL VILLAGE DEVELOPMENT
All units equipped with a Dual gas floor furnace

houses completed by the first of the year. Between 50 and 60 have been completed to date, and by the first of October at least ten were occupied.

BUTTE SURVEY

(Study Will Be Valuable In Low Cost Housing Program)

As an important preliminary step in plans for creation of a \$1,250,000 low-cost housing program under which some 300 four-room homes may be constructed in Butte, State WPA Administrator Joseph E. Parker of Montana has announced approval of a \$40,000 Real Property Survey Project.

The real property survey, he said, will employ 80 to 100 unemployed Butte white collar workers, certified for relief, for a period of six months. Under the blanket authorization of a \$171,754 county-wide statistical project, work is scheduled to begin immediately on the surveying of 15,000 dwellings in the city.

Survey headquarters have been established in the county courthouse and 20 persons previously trained by Irvin A. Purdy, Colorado Col-

lege graduate and an authority on housing research, have begun setting up the project. Between 60 and 80 more persons—95 per cent of whom must come from the relief rolls of Silver Bow County—will be hired for the survey as quickly as they can be selected and trained. Administrator Parker said, with work to be expedited so as to furnish sufficient information as quickly as possible for the formation of a housing agency.

The survey will operate on a procedure established in 179 other cities in the United States under the Federal Works Program. As sponsored in Butte by the Silver Bow County Planning Board and the City of Butte, Mr. Parker explained, the undertaking will embrace two major phases—a dwelling survey and a land use survey. Persons employed must be qualified by experience for enumerators, draftsmen, surveyors, checkers, coders, tabulators, clerks and stenographers.

"The importance of a Real Property Survey to any community can scarcely be over-emphasized," Parker said, "and with Butte now having the opportunity to participate in a large-scale housing program, this work becomes all-important. No program of that nature can be undertaken without definite and accurate information readily available.

"As divided into two major groups, the dwelling survey will provide information as to residential structures and dwelling units, which can be summarized by blocks and also tabulated and analyzed for economic areas and for the city as a whole. It will show the type and

construction of all dwellings in Butte, their age and condition, and the presence or absence of modern conveniences such as plumbing and central heating. It will also show the number of persons who occupy these dwellings, the time they have lived there, and their age, race, the number of roomers and the number of extra families. Such information will be an invaluable guide in formulating any housing program for the community, and in the development of low cost housing, and other similar projects which may later operate in Butte," the State Administrator explained.

"In the second group, the land use survey will provide in summary form, information on the various uses to which all the land in the city is devoted. It will show by blocks, the area covered by existing structures and the areas of land not now in permanent use. This information is vital for future city planning and zoning and for formulating future plans for improving communication facilities, parks, playgrounds and other public enterprises in Butte.

"In order to make the survey a success, the WPA, the City of Butte and the County planning board must have the full cooperation of every citizen," Parker said. He pointed out that all information dealing with specific properties or persons, will be held in the strictest confidence. No list of names or addresses gathered will be used for commercial purposes under any circumstances, and all persons employed under the project will be forbidden, under oath, to give out any information collected during the process of the survey.

MAKING THE PUBLIC STEEL MINDED

By V. G. IDEN

Secretary American Institute of Steel Construction, Inc.

LAST year I read a most interesting book called "The Yearling." It gave an absorbing story of a man, his wife and son, living in the scrub country of back-land Florida. Those three characters depended upon themselves for entertainment, culture and sustenance. Their world was bordered by wild animals and verdant nature. Subsistence was made to appear romantic by the magic of the words of the author. To those three humans, however, life could be interesting only by virtue of their ignorance of what existed beyond their limited horizon.

After attending many group meetings of fabricators of structural steel, I am led to wonder if there is much difference between the viewpoint of many of us and the viewpoint of the three people who populated "The Yearling."

A limited horizon begets a limited existence. If we would wish to spread the benefits of our industry we must step outside ourselves. There are any number of avenues of approach available. These highways are open and for the most part free. To travel these highways merely requires the use of those sources of public relations that most anyone can name upon his fingers.

The public can be approached, for instance, through printed matter — books, pamphlets, magazines, newspapers, letters. You can put your message into motion pictures, photographs, lectures, on the radio, on the stage, in the schoolroom. We can dramatize events which

shape or symbolize your industry and by which this industry may be made known to the public. Hitler has done the same thing to gain his objectives.

We have in this country over 25,000 newspapers and periodicals. The aggregate circulation of our Sunday papers is about 31,000,000, and of our daily papers, over 41,000,000. There are approximately 700 commercial radio stations; American families have some 26,000,000 radio sets. There are 16,000 motion picture theaters, with an average weekly attendance of 115,000,000. There are 260,000 billboards. Some 9,000 new books were published last year. All of these avenues are available upon terms. It is the purpose of public relations to acquaint an industry with those terms and to decide which avenues promise to give you the most immediate and lasting success.

There are approximately 16,000 women's clubs in the country; 2,200 chambers of commerce. Of patriotic groups, the American Legion alone has 11,000 units. There are 1,500 college alumni groups; 1,000 educational societies of one kind or another. Efforts to affect public attitudes today need not be haphazard. Public acceptance can be had whenever, wherever, and howsoever you wish it, provided you are willing to foot the bill. The National Association of Manufacturers has done an excellent job of it.

Willingness to make use of these avenues of approach is not the sole requisite to success, however. First you must know the kind of people you are going to encounter when you venture out of the scrub of the back-lands.

Abstract of a speech before the annual convention of the American Institute of Steel Construction, October 12, 1938.

The nature of that vast public beyond the horizon may be something greatly different from anything you expected.

A great English statesman, when asked whether he saw any chance of permanent peace in the world, made this observation and told his inquirer to draw his own conclusions:

1. That 70 per cent of the people in the world are governed by instinct and emotion and are incapable of reasoning. These are "children of trust."

2. That 10 per cent of the people are militarists, convinced that only militarism can save their country from war's destruction.

3. That 10 per cent of the people are politicians who know how to play on the emotions of the 70 per cent for their personal profit.

4. That 10 per cent of the people are reasonable folk, capable of reliable mass leadership, yet much too honest to compete with the politician for that leadership.

We would be foolish indeed to limit our appeal to that last 10 per cent and ignore entirely the other 90 per cent. To establish cordial relations with that last 10 per cent is easy indeed; the important task is to reach the others.

The 1937-38 edition of the Statistical Year Book issued by the League of Nations is now at hand. The analysis of the 1938 depression is very enlightening and warrants your careful study. For instance, it gives the general indices of industrial production for twenty-five different countries. In the July bulletin issued by the League is the startling disclosure that in each case the United States makes the poorest comparison with 1929 of any of the twenty-five nations.

With 1929 taken as 100, the comparison for 1932 and the latest figures shown for 1938 for eight leading countries are as follows:

Country	1932	1938
Japan	98	179
Sweden	89	146
Germany	53	124
Great Britain	83	124
Italy	67	100
Canada	58	91
France	68	79
United States	54	64

A superficial examination of these figures would seem to indicate that we should either go to war or engage a dictator if we want to be prosperous. The democratic countries, the peace-insuring countries, are the deepest in the doldrums.

I think, however, that it proves something else again. It shows that in those countries where there is the greatest monopoly of industry, a monopoly directed by a single dictator, it is possible to force employment and production by going on a war basis. In those countries the wage scale is the lowest, the standard of living is the lowest, and the increase in employment outside of military service is the lowest. To gain their kind of prosperity we must sacrifice our workmen and our independence and risk our lives. I do not think the goal is worth it.

If it is a greater volume of production without regard to profits maybe we would be wise to get a dictator. If it is prosperity, more opportunities for free employment and a higher standard of living, then let us not forget that it is industry, not politics, which raises the standard of living.

Despite the depression of 1938 we have some reason for feeling optimistic. The per capita consumption of steel was about 2,600 pounds in 1900 and nearly 18,000 pounds in 1937. This would not have been possible had not the product been vastly improved in the meantime and improved methods of using steel developed. Fabricated structural steel constitutes between 12 and 15 per cent of all the rolled products of the mills. While the consumption of all steel has been increasing the relative position of structural steel has not been sliding, which is definite evidence that we have been successful in increasing the market for fabricated structural steel despite all the dark evidence of the depression years.

Structural steel does not depend upon a war to increase its sales. It does not depend upon new political parties or passing phases of popular emotions. Structural steel continues to carry the burdens inherent in buildings and bridges, supporting the constantly shifting loads of commerce and industry.

Garfield once said: "Things don't turn up in this world until somebody turns them up." It's up to us. Individually the problem is too great for most of you to tackle alone. Cooperatively you can do it.

We in the United States have 7 per cent of the world's population and own half of its wealth. Little wonder then that we, 7 per cent of the world's population, have become the envy of the rest of the world.

In other words, despite the rule and misuse of the politicians, the people of the United States have accomplished rather a fairish job for themselves. That is the long-range evidence. Consider the evidence of the immediate present.

The Producers Council devised a new kind of advertising program last winter and launched it cooperatively in the spring. Its theme was that despite all the talk today about wages and material costs, the man who buys a new home is getting much more for his money than he ever did before. Their campaign placed cooperatively in the newspapers and magazines of the country is expected to break down the prejudice against building now.

The moving picture producers have jointly raised a fund of one million dollars to advertise the new pictures and entertainment to be released this fall and winter. They have staked their money on the expectation that the public is at last willing to come back to the avenues and once again spend their money for good entertainment.

The National Retail Dry Goods Association a few weeks ago inaugurated a National Retail Demonstration with the cooperation of the retail stores in some one hundred cities. This campaign has for its purpose to build public confidence in business recovery.

These are not just stray shots in the dark.

A depression is rather deadening to initiative, yet we would be wrong to expect that our competition has been taking it lying down. Have you heard about fire-proof lumber? Are you acquainted with the work of the Wood Products Laboratory? Did you read anything

about the concrete fort built within a few hours—quick-drying cement? Those are not just our competition. Today lumber and cement are our pacemakers.

It need not be questioned, of course, that a mighty transition is under way. New Deal or no New Deal. This has been the natural consequence of a rapid increase in knowledge and the magnitude of technological development. No sensible man complains of change. The great days are when a people are on the march—on the march in laboratories and in the work shops. Those are the places in which competent and efficient people achieve their triumphs.

A new day is dawning. New ideas are developing.

Steel structures are no longer considered ugly. They are not things that must be covered and hidden from sight. We have at last firmly established in the consciousness of the public that materials should be used that can express themselves through the various types of structures. Tradition must not bind us to the old, nor must the new hold a higher position than that to which it is entitled. We should build with the thought that what we build will stand for many decades. If we stamp our structures with the year of their birth, it is sure to bring on premature obsolescence. Oddities have no place in a long term of usefulness. Beauty is accomplished when we design for the needs of the structure, secure the right proportions, make it fit its environment so that it seems to grow into its surroundings, and clothe it with a satisfying color and texture. This requires imagination rather than money. Beauty lives; oddities become liabilities.

Beauty should be expressed in the proportions of the thing built. Beauty can also be expressed in the color or the texture of the materials from which that thing is built. The public is today ready to acknowledge such a beauty in steel construction—a beauty resulting from functional perfection. We should all take profit from the fact that today steel structures are considered beautiful.

A STREET PLAN FOR SAN FRANCISCO

By GEORGE S. HILL

THE evolution of a network of major streets is the key to the solution of the transportation and traffic problems in San Francisco. Such a network should make full use of existing wide streets with suitable grades provided they possess the proper relationship to the plan in its entirety. Such a plan should include important new routes and connections chosen not primarily for ease of construction but rather for the results to be attained in added convenience and utility. San Francisco is a city of many hills and valleys which should be made accessible not only from the business center but from one another. Only in this way will it be possible to secure a well balanced development of all sections of the city.

The elements of such a plan should include:

1. A central perimeter of distribution.
2. Circuit routes.
3. Radials.
4. Crossovers.

The central perimeter of distribution should inclose the central business district and should be of the elongated type. It should not be too small, but should take into account the needs of the future. As there are no streets parallel with Market Street to the north of it, and as a tunnel in Broadway, although desirable and necessary, is too far north to be a useful part of such a perimeter, it is suggested that a bypass tunnel be built parallel with Market Street, under the higher ground. This will serve as an express tunnel from the proposed Fulton Street Parkway, to emerge in the vicinity of the California Street business section, where one of the narrow streets north of California Street, such as Clay Street, could be widened. The Embarcadero, Brannan and Tenth Streets would complete the perimeter. The extension of Tenth

Street in a straight alignment to Van Ness Avenue is suggested.

The first circuit route outside of the perimeter of distribution would consist of the Divisional Highway, 26th Street and Army Street. The Divisional Highway has been advocated for several years by a number of improvement clubs forming the Divisional Highway Association. The route includes Divisadero Street, which is the first wide street west of Van Ness Avenue. It is planned to reconstruct the roadway 60 feet wide and to secure the re-routing of car lines to other streets. The north end of Divisadero Street is to be tunneled to the Marina District, giving the central portion of the City a more direct approach to the Golden Gate Bridge. The Divisional Highway Association has been instrumental in having Divisadero Street connected with Castro Street. Eventually the route will be extended through the Eureka and Noe Valleys to connect with San Jose Avenue. Because of topographic barriers, Divisadero and Army Streets are the natural limits of the business district in the larger sense, that is, including the Fillmore and Mission business districts.

The second circuit route outside of the perimeter of distribution would be a combination of Seventh Avenue, Woodside Avenue, O'Shaughnessy Boulevard, Bosworth Street and Silver Avenue.

The third circuit route would include Geneva Avenue, Ocean Avenue and Sunset Boulevard.

The principal radials would be, in rotation, the Embarcadero, Columbus Avenue, Broadway, Fulton Street, Market Street, Harrison Street (extended), Potrero Avenue and Third Street. As all radial streets should be as direct

as possible, an effort should be made to so plan them as to provide for their ultimate extension entirely through the City, largely eliminating detours. For example, Broadway, after the construction of the tunnel from Mason Street to Larkin Street, will have an excellent grade from the Embarcadero to Fillmore Street. However, it would have but limited value unless provision were made for its ultimate extension along the south boundary of the Presidio to the Cliff House. The eastern end eventually would be elevated to connect with an elevated drive along the Embarcadero similar to that along the docks in New York City. A new outer bridge would be built at the Channel.

which is now a greatly overloaded street. The Noe Valley particularly would be made more accessible by the extension of Harrison Street. If located on the axis of Mt. Davidson it might appropriately be renamed Mt. Davidson Avenue.

The principal cross-over streets would be Van Ness Avenue South and Duboce Avenue. Both of these, or routes near them, should be developed as express parkways. At their intersection, there should be built a continuous flow intersection, but without the left turn. The function of the cross-over streets would be similar to that of the cross-over tracks in the throat of a railroad terminal yard. These permit a selection of routes and a cross-over to the far side of the terminal or the perimeter.

It is recognized that even though the number of streets included in such a network is reduced to a minimum, the various connections required would result in a very ambitious program. However, a street system is not evolved or built in a day and, therefore, the more obvious improvements should receive first consideration. A broadening out of the central business district is essential, utilizing more fully the parallel streets south of Market Street and bypassing part of the Market Street traffic.

In general it would be inadvisable, and wholly unnecessary at this time to construct a system of elevated streets in downtown San Francisco, although later some elevated links may be necessary and desirable, particularly over railroad yards and industrial areas and along the Embarcadero. Elevated streets or bridges along or across Market Street should be avoided or the value and charm of the street will be obliterated. Furthermore, too much emphasis has been placed upon the effect of the two bridges upon the street system, which though important should not obscure the need for the development of an adequate street system for the residents and business men of San Francisco.

Figure 1 shows in diagram form the elements above described.

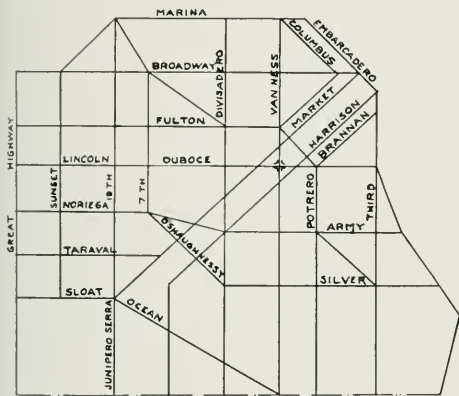

FIG. 1.

Columbus Avenue would be extended a short distance at both ends; at the inner end to the perimeter of distribution, and at the outer end to Jefferson Street.

Fulton Street would be developed as a parkway, and widened along the edge of Golden Gate Park.

Market Street would be made more direct by constructing a vehicular tunnel under the Twin Peaks. Its length would be about 5,000 feet and the grade 4 per cent.

Harrison Street has acquired a new significance since the completion of the Bay Bridge. Its extension across the Mission District and southwest through the Noe Valley would be of the greatest value in relieving Market Street,

World's Fair Builders

EDWARD L. FRICK

If Edward L. Frick emerges from the Pageant of the Pacific a trifle flattened on both facades, it will be because he spent his time squarely between the upper and nether millstones of the Treasure Island show.



EDWARD L. FRICK
CHIEF, DIVISION OF ARCHITECTURE
Golden Gate International Exposition

On one hand were six architects, who wanted to see contracts let for construction of their rosiest dreams; on the other hand was Will Day, who kept one eye on beauty and the other on the budget. As Chief of the Division of Architecture for the 1939 Golden Gate International Exposition, Ed Frick is liaison-man between these two forces; he reports to Day as Vice-President and Director of Works, freighted with messages from the artistic architects.

There's a certain tension about such a job, and maybe Ed Frick stood the pressure better because he was on familiar ground. He was born in San Francisco and went to old Poly

High at 585 Bush Street, where the Exposition's downtown headquarters building stands now. Poly High fell down in the fire of 1906, and the lot stood vacant until the Exposition building was built there. Now Ed Frick is right back at the old stand, practicing architecture where he first took a fancy to the profession.

From old Poly High, Frick broke into architecture through San Francisco offices in 1908. Four years later in a competition for an open air theater in an exposition he won the Traveling Scholarship of the Architectural League of the Pacific Coast, and he went to Paris, France, for study in 1913. In April of 1914 he entered the Ecole des Beaux-Arts, but the war closed the school in August and he returned to San Francisco, to work with Bakewell & Brown on the San Francisco City Hall and on the Palace of Horticulture of the Panama Pacific International Exposition.

When the United States declared war he enlisted in the Engineers Corps in 1917 and returned to France under military auspices. After twenty months of foreign service he was demobilized there, completed his studies at the Ecole des Beaux-Arts, traveled extensively in Europe, and in 1923 returned again to Bakewell & Brown. He worked as a designer on such important buildings as the general office building for the Pacific Gas & Electric Company, Pasadena City Hall, buildings at Stanford University and the University of California.

Ed Frick has worked on two previous expositions, the Panama Pacific International Exposition and the Century of Progress at Chicago. Upon dissolution of the firm of Bakewell & Brown in 1927, Frick continued with Arthur Brown, Jr. and was the principal assistant on the Department of Labor and Interstate Commerce Commission buildings in the new Triangle Group in Washington, D.C., and on the Tower of the Sun and its surrounding Court of Honor on Treasure Island.

After death of George W. Kelham, Frick became Chief of the Division of Architecture on recommendation of the Architectural Commission.

He plays golf when he can, and is a member of the California Golf Club.

WINDOW CONDITIONING

By EARL AIKEN

THE oldest form of home insulation—double-glass windows—is arousing nation-wide interest among architects, builders and the public for several reasons.

First, because of the many improvements that have been made in storm sash and prefabricated double-sash units by leading manufacturers; secondly, because of the comfort, health and economic advantages proven by recent unbiased surveys; third, because such "window conditioning" pays for itself in fuel saving in two heating seasons, depending upon the locality; and because such insulation can be obtained through an FHA loan, with no down payment.

That "window conditioning" a home will soon be standard procedure in much the same way that many modern methods have become established building requirements, and that it will be demanded, is already indicated by the flood of letters from home owners who have expressed enthusiasm over the advantages of insulation.

Because of its desirability, many architects and builders look upon window conditioning as a convincing sales factor, particularly advantageous because it can be quickly recognized by the home-seeking shopper. The prospect doesn't have to take anybody's word for it.

Many builders in eastern and middle west areas are considering the idea of attaching a plaque or metal sign to furnaces in new or modernized homes offered for sale with such wordage as: "This home is window conditioned for greater comfort, better health and lower fuel cost."

It is an established scientific fact that during the heating season, heat losses occur through uninsulated windows and doors as well as through uninsulated walls, roofs and floors.

Window conditioning will save approximately 23% of the fuel used in the typical uninsulated suburban residence, according to the results of a study of four representative houses in Metropolitan New York, made by Alfred J. Offner, consulting engineer, past-president of the New York Society of Consulting Engineers, and treasurer of the American Society of Heating and Ventilating Engineers. These calculations were based on the use of outside storm sash and storm doors on all openings or the equivalent use of modern double-glazed (weather-stripped) casement windows instead of ordinary windows.

If these houses had been well insulated before they were window conditioned, Mr. Offner's figures show that of the remaining fuel cost for an insulated house, window conditioning would save from 30 to 36 per cent.

Professor G. L. Larson, head of the mechanical engineering department of the University of Wisconsin, carefully calculated the economic value of insulating and window conditioning his own residence in Madison,



Window Conditioning (double-glass insulation) may be accomplished with storm sash or winter windows which hang from the same fastenings used to support screens in summer. Note how readily the storm sash "blends" in with its surroundings.

Wisconsin. He found that every step he might take toward saving fuel in his own home paid for itself in time, but that window conditioning (storm sash and storm doors) returned its cost first.

An investment of \$106 showed a net saving of \$77.40 per year—a return of 73 per cent on his money. It would pay for itself before the second winter was half over. No other method produced such a high return.

* * *

Window conditioning does more than merely cut down fuel bills. It checks cold drafts and prevents fogging on windows. It is essential to satisfactory winter air conditioning with its higher healthful humidity.

Cold glass surfaces condense the moisture carried by indoor air and thus cause fog, frost or even dripping water to form on window panes. This moisture comes from cooking, bathing, laundering and from the use



It requires only a few minutes to Window Condition a home that is equipped with modern prefabricated double-glazed sash. The glass is quickly and securely fastened into a special recess provided to receive it.

of a humidifier to keep the air indoors healthfully moist.

We need this moisture. It keeps us in better condition to resist colds and respiratory diseases. We do not want fogging or frost on windows nor water running over window sills.

Window conditioning, double-glass insulation, keeps the inner pane of glass comparatively warm even though the outer pane may be as cold as the outdoor air. This prevents condensation from taking place on the inner pane of glass and keeps windows dry and clear in sub-zero weather.

Window conditioning fits every style of architecture. Until recently, however, little attention was paid to the appearance possibilities of double glazing. Storm sash were merely added for protection without thought to architectural values.

But modern architects are skilled at making such useful and desirable advances fit beautifully into the houses of today. Three simple principles point the way toward making window conditioning an adjunct to beauty as well as a source of comfort.

The first is to use large areas of glass in winter windows. If division bars or muntins are needed to keep the glass size within practical limits, they should be placed to match the main division lines of the permanent window. For example, winter windows for double-hung sash may have a single horizontal muntin at the level of the meeting rail where the upper and lower sash come together. This principle saves cost, eliminates unnecessary obstructions to the view and makes windows easier to clean.

The second is to paint the winter windows to match the color of the sash in permanent windows. This simple recommendation makes the winter windows blend with the prevailing treatment of the house so that they become almost unnoticeable when in place. There is no advantage in changing the color scheme, inside or out, when you put on or remove the double-glass insulation.

The third principle is to specify a high quality of clear glass for winter windows. With double glazing, glass quality is doubly important since occupants are looking through two pieces of glass instead of one.

COURT RULING AFFECTS PRACTICE OF ARCHITECTURE IN CALIFORNIA

MEMBERS of the California State Board of Architectural Examiners and their investigating agent are exempt from liability for acts done in performance of their official duties, according to a ruling by the Superior Court of Los Angeles County, following a civil action against them for damages for alleged false arrest and malicious prosecution. The ruling is of great importance as affecting the Board and the practice of architecture.

The case involved grew out of an action which was filed against Russell Long, contractor, by the State Board of Architectural Examiners, South District, for a violation of the Act Regulating the Practice of Architecture in which a verdict was rendered in favor of the defendant.

Long, being the victor, thereupon brought a civil action against the Board and Ben G. Silver, investigator for the Board, in the sum of \$50,000 for "false arrest and malicious prosecution."

The name of an architect appeared upon the disputed plans, who, upon being questioned, stated to the members of the Board and the deputy city prosecutor that he was not a partner in the transaction. Based upon his statement and a careful investigation, action was brought against Long.

At the trial, the architect testified he was a partner, which destroyed the value of the Board's evidence and Long received a verdict of "not guilty."

Long then filed civil action against the Board and Ben G. Silver. The architect in question again testified that he was a partner. However, the instructed verdict of the judge to the jury, as recorded below, is of interest and was in accord with the plea for such instructed verdict as presented by the deputy attorney in his address to the court:

In the Superior Court of the State of California in and for the County of Los Angeles, Department 15, L. C. Drapeau, Judge Presiding.

Russell Long, plaintiff, vs. Ben. G. Silver, et al., defendants (No. 426741).

Reporter's transcript of court's oral decision upon defendant's motion for a directed verdict in favor of the defendants, and court's oral instruction to the jury to return a verdict in favor of the defendant.

Los Angeles, California, Friday, September 23, 1938, P. M.

The Court: Well, it has been a very interesting matter to listen to and to analyze. I have gone over all the cases cited by counsel. Last night, I didn't have much doubt in my mind, as far as the members of this Board

are concerned. I think the burden is on the plaintiff to establish that the members of the Board were individually active participants in the securing of the complaint and the malicious prosecution. I was more or less concerned with just where Mr. Silver fitted into this picture. However, I am bound by the decisions of the Courts of Appeal of this State. The latest case is the case of White vs. Brinkman, 23 Cal. App. Second, at page 307. That squarely holds up and down, reading from the syllabus—reading from page 308 of the opinion: "The exemption of judicial or quasi-judicial officers from liability for acts done in performance of their official duties has been established not primarily for the protection of such officers, but as a better assurance of fair and impartial administration of justice, without fear or favor, in the protection of life and property. The immunity applies even despite malicious or corrupt conduct in the exercise of jurisdiction."

With that law, enunciated in 1937, and with it applied to the City Manager of the City of Berkeley, to the Building Inspector in a case nearly on all fours with this case, I feel I am bound by that decision, and that is the law of the case. Therefore, the Court will grant the motion on all the grounds urged, and if the bailiff will call the jury, we will direct a verdict.

(Whereupon the jury returned to the jury box, and the following proceedings occurred in the presence of the jury.)

The Court: "Members of the jury, there are cases in which the Court is called upon to direct a verdict. I have tried cases in my time as a practicing lawyer, and at other times, occasionally, have had occasion to direct verdicts. It has always seemed to me that it is more or less fair to the jury for the Court to explain briefly why the Court directs the verdict of the jury. That occurs when the Court believes it is its duty as a matter of law to determine that the facts are entirely one way, and that if the case were submitted to you as members of the jury, and you found contrary to the way the Court looks at it, it would be the duty of the Court to grant a new trial, and to have the County and everyone connected with the matter put to the expense of trials and retrials.

"In this particular matter, there is a line of authorities in the State of California, binding upon this Court, which hold that a Board or a public officer, engaged in his official duty, is immune from actions for malicious prosecutions of this nature. That has been the subject of some of the argument that has been going on in the absence of the jury at all times since yesterday, and during today. However, I have finally and definitely

made up my mind that under the law of California, this Board of Architectural Examiners, and Mr. Silver, who was their investigating agent, are immune from prosecution for malicious prosecution in a tort action, such as this. Therefore, it becomes my duty to direct you to bring in a verdict for the defendants in this case."

AMEND REGISTRATION ACT

A special committee on legislation from the California State Board of Architectural Examiners, Northern and Southern Districts; the State Association, Northern and Southern Districts, and the Southern California Chapter A.I.A., met at the Biltmore, Los Angeles, in September, for the purpose of reviewing and approving amendments to the Act to Regulate the Practice of Architecture.

For the past year the State Boards and a special committee have had in preparation amendments to the Act to be submitted to the next session of the Legislature. The codified act as now in force and the proposed amendments will constitute a new Architectural Practice Act affecting those who are licensed to practice architecture, strengthening its regulatory and disciplinary provisions.

The amendments were unanimously approved and will be submitted to the convention for adoption. Recommendations were also made that the Act be amended to combine the Northern and Southern District Boards of Architectural Examiners into a single State Board with headquarters at San Francisco and Los Angeles.

Of professions under the jurisdiction of the Department of Professional and Vocational Standards, Architecture is the only one operating in a dual capacity with two state boards. It is the opinion that one state board will serve the architectural profession more effectively.

Those attending the meeting were: Harry M. Michelsen, Frederick H. Meyer, Frederick H. Reimers and Warren C. Perry of San Francisco; Harry J. Devine, Sacramento; Harold E. Burket, Ventura; Sylvanus B. Marston, Pasadena; Lester H. Hibbard, Earl T. Heitschmidt, A. M. Edelman, Harold C. Chambers and Robert H. Orr, Los Angeles and State Code Commissioner McHenry.

NORTHERN CHAPTER MEETING

The regular meeting of Northern California Chapter, A.I.A. was held at the St. Francis Yacht Club, San Francisco, Tuesday, November 1, the meeting for October being postponed to this date. President Warren C. Perry presided.

Members present: Messrs. Harris C. Allen, John Bakewell, Jr., John K. Branner, Albert J. Evers, Edward R. French, Jr., Edward L. Frich, Andrew Hass, Wayne S.

Hertzka, Lawrence A. Kruse, Charles F. Masten, Leffler B. Miller, James H. Mitchell, Howard Moise, Irving F. Morrow, John B. McCool, Gwynn Officer, Lennart Palme, Warren C. Perry, Eldridge T. Spencer, Roland I. Stringham, Ernest E. Weihe.

Guests: Messrs. Wilson, Gould, Lloyd, Nussbaum, Solon.

Mr. Palme and Mr. French were announced new member and associate, respectively, on this occasion of their first attendance at a Chapter meeting.

The work of Ernest Born in arranging and directing the recent architectural exhibit of the Chapter was highly commended by Mr. Perry and other members. It was unanimously voted as a slight token of appreciation to extend to Mr. Born for his able effort an Associateship in the Chapter with initiation fee and dues for one year remitted.

There followed a discussion of the advisability of permitting a commercial trade association to take over the late exhibit as a travelling exhibit. Mr. Weihe moved that the offer which had been made, be rejected. The motion was carried with one dissenting vote.

It having been stated in the course of the discussion that civic or art groups might well continue the exhibit, Mr. Bakewell moved and it was carried that any such disposition be left to the decision of the Executive Committee.

Mr. Morrow informed the meeting that approval is being sought for a residential subdivision along the bay side of Marina Boulevard on property which has generally been thought of as future park property. He moved that the Chapter go on record to deplore the proposed subdivision and send copy thereof to the Board of Supervisors with request that the city acquire the property for park use. It was included in the motion that copies of this action be sent to other interested organizations. The motion was unanimously carried.

Charles F. Masten, chairman of the membership committee, reported on the effort of the committee to secure new members. He was encouraging in his belief that this campaign would soon bear fruit.

Mr. Moise voiced a few remarks against the backwardness of architects to display larger signs on their buildings while under construction. He and others even felt that permanent signs should be placed in buildings to proclaim the source of their design.

The program that followed was a happy climax to a very interesting meeting. John B. McCool, lately returned after a year's absence, was the speaker.

During the time he was away it had been his privilege to perform archeological work for the Persian Government under the Institute of Iranian Archeology. Mr. McCool was the architect member of the 1938 expedition which was directed by Dr. Arthur U. Pope.

The account of his trip, work and experiences, as related to the Chapter members, was exceedingly interesting.—James H. Mitchell, Secretary.

ARCHITECTS' BULLETIN

Issued For

THE STATE ASSOCIATION OF CALIFORNIA ARCHITECTS
Northern Section

STATE ASSOCIATION MEMBER
OF THE
AMERICAN INSTITUTE OF ARCHITECTS
Editor

Harris C. Allen

Address all communications for publication
in the Bulletin to the Editor (Harris C.
Allen) 557 Market Street, Room 218, San
Francisco, California.

Board of Control

Harris C. Allen Otto G. Hintermann
Harry Michelson Wayne S. Hertzka

State Association Officers

President Sylvanus B. Marston, Pasadena
Vice-President Gwynn Officer, Berkeley
Secretary Wayne S. Hertzka, San Francisco
Treasurer Robert H. Orr, Los Angeles

Regional Director, A. I. A.

Albert J. Evers, San Francisco

Deputy Regional Director, Southern
California

Gordon B. Kaufmann, Los Angeles

Executive Board—Northern Section

Officers

President Gwynn Officer, Berkeley
Vice-Pres. Ernest E. Weihe, San Francisco
Secretary Wayne S. Hertzka, San Francisco
Treasurer Otto G. Hintermann, San Francisco

Directors

Harry J. Devina R. H. Reimers
Wm. J. Merchant Harold Weeks

Executive Board—Southern Section

Officers

President Sylvanus B. Marston
Vice-President Louis N. Crawford
Secretary Winsor Soule
Treasurer Robert H. Orr

Directors

Merrill W. Baird Abe Edelman
Harold C. Chambers George D. Riddle

Advisors—Northern Section

Harris C. Allen San Francisco
J. K. Ballantine, Jr. (Secretary)
Sam. Lightner Hymen
Wm. G. Merchant
Jas. F. McGuiness
Dodge A. Riedy
Harold H. Weeks
Ernest E. Weihe
Albert R. Williams
Fred. H. Reimers (President)
C. A. Caullins North Bay District
Peter Sala Lower San Joaquin
 District
J. U. Cloudsley (Secretary)
Edw. W. Kress Santa Clara Valley
Mario Corbett San Mateo
Alden Cambell Sacramento
Ernest J. Kump Upper San Joaquin
Dole F. Thomsen Palo Alto
Norman W. Sexton Marin
Geo. P. Simonds East Bay
Chester Treichel East Bay
Gwynn Officer Berkeley
F. T. Georgeson Redwood Empire
Casebo'l Dakin Upper Sacramento
Ralph Taylor Lassen District

1938 CONVENTION

A DEFINITE and decided spirit of unity characterized the Eleventh Annual Convention held in San Francisco, October 13-15, 1938. Internal business was transacted efficiently and promptly, without undue discussion or apathy. General policies of the Association were defined and approved, and their execution assigned to the Executive Board with directions as to practical and feasible conditions. Certain aspects of public affairs which affect the building industry, and architects either directly or indirectly, were presented to the Convention and will be considered both by the Board and by the profession at large. There were continued and strengthened ties of increasing acquaintance, and common interests, which have built up the Association during its ten years existence.

ATTENDANCE

Although the Convention was located in San Francisco to enable more members to attend than is usually possible at a more isolated place like Del Monte, the attendance at business sessions was smaller than expected—about 50 or 60. This was due partly to the fact that many architects are very busy now, largely with P. W. A. projects, and partly to the difficulty we all experience of arranging our time when we are at home and available for business calls and appointments. The arguments would seem to be confirmed of those who insist that a Convention held away from a large center receives more concentrated attention from delegates, and has less distraction of interest and attendance.

At the special functions, however, many more were present; over 100 at the Friday luncheon, and over 300 at the Convention Banquet Friday night.

BUSINESS

After reports on the past year's activities by president and secretaries, Frederick H. Meyer explained and commented on the new Act to Regulate the Practice of Architecture, which has been prepared by the State Board of Architectural Examiners in view of the fact that the present Act was to be codified, along with many other Acts, for submission to the Legislature at its next session. In the new Act there are no controversial issues; it is purely a measure to regulate the profession. Printed copies will be sent to all members of the Association as soon as ready. The Convention approved the Act and authorized a special Legislative Committee to conduct the necessary procedure in connection with its submission to the Legislature.

After much discussion over the restrictions of Civil Service employment on work for the State of California, which affect not only architects and engineers but contracts of all kinds, the Convention passed a resolution authorizing the Executive Board to investigate and, if possible, act with other inter-



COOPERATIVE GAS INDUSTRY BUILDING AT TREASURE ISLAND

GAS EXHIBIT AT GOLDEN GATE EXPOSITION

Animation, color and lively interest will feature the Pacific Coast Gas Association cooperative exhibit at the Golden Gate International Exposition. Utilities and

On October 11th at the San Francisco Engineers' Club, the San Francisco Section held a joint meeting with the San Francisco Engineering Council. After dinner there was a demonstration lecture at the P. G. & E. Auditorium on "Sounds, Ears, Noises and Acoustical Measurements and Their Relation to Machinery Quietening." The speaker was Dr. Ernest J. Abbott, President of Physicists Research Company.

The Section will hold its annual party this year at Treasure Island with an exposition preview and other features. The date is October 22. A. R. Tudor is chairman of the entertainment committee.

Engineers to Meet at El Encanto

The annual convention and outing of the Northern and Southern Sections of the Structural Engineers of California will be held this year at the beautiful El Encanto Hotel, Santa Barbara. Last year's convention was held in Pacific Grove. The Southern Section will do the entertaining this year so a Southern California city was selected for the meeting.

El Encanto Hotel is said to be greatly improved in accommodations and cuisine since it was taken over by Frank McCoy, owner of Santa Maria Inn where the engineers met three years ago. A splendid time is promised those who attend. The dates: October 28-29th.

manufacturers from Hawaii to Texas are cooperating in a novel display at which visitors can see, feel and hear the latest automatic gas appliances for cooking, house heating, refrigeration and water heating.

In the Golden Gate end of the Homes and Gardens Building, a floor area of some 10,000 square feet is being transformed into a beautiful Spanish court which will enclose the gas industry exhibit. Architectural variety has been accomplished to an unusual extent.

There is a public concourse of about 3,672 sq. ft., with a seating capacity of 164. The main point of interest here is a large window panel of a Spanish house. This window actually becomes a proscenium to a revolving stage on which are shown modern gas appliances within a series of six beautiful kitchens, and a model utility room, styled to the step-saving, convenient home of today.

These stage features are presented individually at four-minute intervals on a 35 ft. revolving steel platform which sets up each stage automatically; chimes announce the curtain, and the show is on.

On these stages the appliances do their own acting, showing off their various features and accompanied by spoken description. There appear also projected natural color photographs illustrating the various cooking operations as the features are presented by the range in action. When the appliance has completed its presentation, it quietly folds up, the curtain closes, and the next stage is set up and made ready.

(Please turn to Col. 2, Page 58)

With the Architects

NEW SCHOOLS AND ADDITIONS

Architects on the Pacific Coast who specialize in school designs are especially busy with work at this time, due mainly to generous allotments of PWA money. The list includes:

A \$50,000 addition to the Hayward High School, Henry C. Smith of San Francisco, architect.

Classroom addition to the Brentwood-Deer Valley School, Frederick H. Reimers, San Francisco, architect.

Cafeteria and domestic science wing to Taft Union High School, Franklin & Kump, architects, Fresno.

Auditorium and class room addition to Lafayette Grammar School, E. Keith Narbitt, architect, Richmond.

Science room addition to Gonzales Union High School, Chas. E. Butner, architect, Salinas.

Bonds have been voted for a group of new high school buildings at Carmel to cost \$300,000. No architect has been named as yet.

A \$40,000 addition to the San Andreas Grammar School, Geo. C. Sellon, architect, Sacramento.

Auditorium and gymnasium at Gustine, Merced County to cost \$65,000, Franklin & Kump, architects, Fresno.

Group of grammar school buildings at Exeter, Tulare County, H. L. Gogerty, Los Angeles, architect.

Bonds for \$600,000 have been voted for new Junior High School buildings at Santa Rosa, Harold H. Weeks, architect, San Francisco.

A 12-room class room building at the Mastick School, Alameda, from plans by Kent & Gass, architects, San Francisco.

Alterations and additions to the Colton Grammar School, Monterey, Robert Stanton, Del Monte, architect.

Group of High School buildings at Corcoran, Kings County to cost \$200,000, H. L. Gogerty, architect, Los Angeles.

Completion of High School shop building, Berkeley, \$165,000, Corlett & Gutterson, Oakland, architects.

Eleven class room addition to Burbank School, Santa Rosa, Wm. Herbert architect, Santa Rosa.

Additions aggregating in value \$500,000 to Vallejo High School, John J. Donovan, architect, Berkeley. Also additions to Niles High School, \$150,000.

THEATER AND STORES

A. A. Cantin of San Francisco has completed plans for a one-story reinforced concrete theater and store

building to be built at Brown Avenue and Hopkins Street, Oakland, for J. Catucci, 1212 18th Avenue Oakland. The estimated cost is \$50,000.

TWO MILLION FOR S. F. SCHOOLS

PWA grants have been approved and bonds voted for the following new school work in San Francisco:

Haight School, Outer Mission District	\$ 900,000
First unit, Abraham Lincoln High School	750,000
Junior College buildings	1,366,032
Auditorium, Geo. Washington High School	325,000
Second unit, Samuel Gompers School	190,000
Kindergartens at Francis Scott Key, Visitation and Glen Park Schools	70,000
Geo. Washington High School athletic unit	438,555
Horace Mann gymnasium and cafeteria	151,291
Portola Junior High School auditorium	68,348
Franklin School addition	47,562
Francis Scott Key addition	61,734
Lawton auditorium and kindergarten	67,930

PERSONALS

P. P. Lewis, formerly located at 1063 Westwood Boulevard, West Los Angeles, announces the removal of his offices to Room 208, Chapman Building 10929 Weyburn Avenue, West Los Angeles.

Sumner M. Spaulding, architect and C. Gordon Deswarte, structural engineer, formerly located at 9441 Wilshire Boulevard, Beverly Hills, announce the removal of their offices to 3305 Wilshire Boulevard, Los Angeles.

C. H. Russell, architect, has moved from 1340 S. Berendo Street, to 1110 S. New Hampshire Avenue, Los Angeles.

A. C. Zimmerman, architect, has moved from 709 H. W. Helman Building, to suite 611 Architects Building, Los Angeles.

Ralph C. Flewelling, architect, has moved from 614 Architects' Building, Los Angeles, to suite 611 in the same building.

Richard J. Neutra of Los Angeles, has received notice of award of a bronze medal for his designs of the Gertrude Kun residence at Altadena, and a school building at Bell, exhibited at the Paris International Exhibition, Paris, in 1937.

Palmer Sabin has moved his office from 170 E California Street, Pasadena, to 3305 Wilshire Boulevard, Los Angeles.

PERSONALS

Professor **Charles Derleth, Jr.**, Dean of College of Engineering, University of California, has recently been appointed a member of the Technical Advisory Board of the American Institute of Steel Construction. Dean Derleth was a member of the Consulting Board of Engineers on both the San Francisco-Oakland Bay Bridge and the Golden Gate Bridge and is a nationally recognized civil engineer.

Thomas F. Chase, C. E., has recently opened offices in the Phelan Building, San Francisco.

Wallace B. Boggs, C. E., announces the opening of offices at 1404 Franklin Street, Oakland.

Everett C. Shuman, professor of civil engineering at Lewis Institute, Chicago, has been elected president of the American Association of Engineers, and **Edward H. Clarkson, Jr.**, civil engineer in the city engineering bureau of Los Angeles, vice-president.

A. Godfrey Bailey will conduct a class for students interested in carpentry at the Frank Wiggins Trade School, Los Angeles, on Tuesdays from 6:15 to 9:15 p. m. during the fall and winter.

William V. Kernan has moved his offices from 632 Board of Trade Building to 250 North Rampart Boulevard, Los Angeles.

SOUND CONTROL CONTRACTORS

The United States Gypsum Company announces appointment of the Van Arsdale-Harris Company, the Acoustical and Insulation Division of the Van Arsdale Harris Lumber Co., Inc., with offices at Fifth and Branran Streets, San Francisco, as exclusive district contractor on all U. S. Gypsum Company sound control products.

Architects, engineers and contractors in California and Nevada are invited to call on the Van Arsdale Harris Company for immediate information, acoustical analyses and bids, on USG Acoustone, Perfatone, Quietone and Trembar Machine Bases. Van Arsdale Harris Company admittedly is well qualified to supply such expert information on sound corrective constructions and to erect them competently.

Best sound control results are obtained from the combination of trained and experienced engineering, construction service, and good products. In the appointment of the Van Arsdale-Harris Company to handle USG Sound Control Products, one finds an excellent combination of these factors.

POST OFFICE BUILDING

A new post office building will be constructed at Linden and Miller Avenues in San Mateo County for the City of South San Francisco. The government has appropriated \$111,000 for the improvement.

EDWARD LANGLEY SCHOLARSHIPS

The American Institute of Architects from January 1 to March 1, 1939, will receive proposals of candidates for Edward Langley Scholarships for the year 1939.

Awards will be announced about June 1, 1939.

Awards may be made to residents of the United States and Canada.

These scholarships are awarded annually for advanced work in architecture, for study, travel, or research, as the holder of the scholarship elects. Awards to undergraduates are precluded, but awards may be made to architectural draftsmen who desire to do undergraduate work or take special courses in architectural schools. An award in a succeeding year to a holder of a scholarship is not precluded.

Competitive examinations will not be used as a method of selection.

The scholarships are open to all persons engaged in the profession of architecture. To facilitate making the awards, such persons are grouped as follows:

Group 1:

- (a) Architects in active practice;
- (b) Architectural draftsmen employed by architects, whether the draftsmen are engaged in drafting, writing specifications, supervising, or acting as executives, and whether or not they are college graduates.

Group 2:

- (a) Teachers in schools of architecture;
- (b) Students about to graduate from such schools.
- (c) Graduate students of such schools who are engaged in post-graduate work either in college or in travel.

The awards will be made and the grants determined by a committee of the board of directors of the Institute. In making awards, all candidates from both groups will be considered as a single group by the committee, and scholarships will be awarded to those who, in the judgment of the committee, are best qualified therefor by reason of character, ability, purpose, and need, regardless of place of residence or whether they are Group 1 or Group 2 candidates.

A VISIT TO THE ATHENEUM

The Engineers and Architects Association of Southern California held an enjoyable field day and dinner Friday, October 28.

The members visited the Atheneum of California Institute of Technology, 1201 East California, Pasadena, and viewed the model of the "Palomar" telescope and the great lens which is being ground there.

WASHINGTON SKETCH EXHIBIT

Until December 4 at the Seattle Art Museum, the annual sketch competition will be held by the Washington State Chapter, A.I.A., with George Gove, Tacoma, in direct charge. The drawings will probably be shown later at Tacoma, Spokane, Pullman and Moscow.

Estimator's Guide

Giving Cost of Building Materials, Wage Scale, Etc.

Amounts given are figuring prices and are made up from average quotations furnished by material houses to San Francisco contractors. 3% Sales Tax on all materials but not labor.

All prices and wages quoted are for San Francisco and the Bay District. There may be a slight fluctuation of prices in the interior and southern part of the state. Freight charge at least, must be added in figuring country work.

and—1/2% amount of contract.

rickwork—

Common, \$40 to \$45 per 1000 laid, (according to class of work).

Face, \$100 to \$110 per 1000 laid, (according to class of work).

Brick Steps, using pressed brick, \$1.25 lin. ft.

Brick Veneer on frame buildings, \$.75 sq. ft.

Common f.o.b. cars, \$14.00 at yard. Cartage extra.

Face f.o.b. cars, \$45.00 to \$50.00 per 1000, carload lots.

OLLOW BUILDING FIREPROOFING (f.o.b. job)

3x12x12 in.	\$ 84.00 per M
4x12x12 in.	94.50 per M
6x12x12 in.	126.00 per M
8x12x12 in.	225.00 per M

OLLOW BUILDING TILE (f.o.b. job)

carload lots.	
8x12x5/2	\$ 94.50
6x12x5/2	73.50

ilding Paper—

1 ply per 1000 ft. roll	\$3.50
2 ply per 1000 ft. roll	5.00
3 ply per 1000 ft. roll	6.25
Brownstn, 500 ft. roll	4.50
Brownstn, Pro-lect-a-mat, 1000 ft. roll	9.00
Sisalcraft, 500 ft. roll	5.00
Sash card com. No. 7	\$1.20 per 100 ft.
Sash card com. No. 8	1.50 per 100 ft.
Sash card spot No. 7	1.90 per 100 ft.
Sash card spot No. 8	2.25 per 100 ft.
Sash weights cast iron, \$50.00 ton.	
Nails, \$3.50 base.	
Sash weights, \$45 per ton.	

Concrete Aggregates—

Gravel (all sizes) \$1.45 per ton at bunker; delivered to any point in S. F. County \$1.85.

	Bunker	Delivered
Top sand	\$1.45	\$1.85
Concrete mix	1.45	1.85
Crushed rock 3/4 to 3/4	1.60	2.00
Crushed rock 3/4 to 1 1/2	1.60	2.00
Graveling gravel	1.60	2.00
1/2" gravel	1.45	1.85
6" river sand	1.40	1.80
Delivered bank sand—\$1.00 per cubic yard at bunker or delivered.		

AND—

	Bunker	Delivered
River sand	\$1.40	\$1.80
Lapis (Nos. 2 & 4)	2.00	2.40
Olympia Nos. 1 & 2	1.80	2.20
Heldsburg oyster sand	\$1.80 and \$2.20	
Del Monte white	—	50c per sack

EMENT (all brands, cloth sacks) \$2.72 per bbl. f.o.b. car; deliv. \$2.90 per bbl. carload lots; less than carload lots, warehouse or delivered, 83c per sack. (Less 10c per sack returned, 2% 10% Prox.)

Common cement (all brands, paper sacks) carload lots \$2.52 per bbl. f.o.b. car; delivered, \$2.70; less than carloads delivered, 75c per sack. Discount on cloth sacks, 10c per sack. Cash discount on carload lots, 10c a barrel, 10% Prox.; cash discount less than carload lots, 2%.

Atlas White } 1 to 100 sacks, \$1.50 sack,
Calaveras White } warehouse or delivery; over 100
Medusa White } sacks, \$1.25; 2% discount 10th of month.

Forms, Labors average \$40.00 per M. Average cost of concrete in place, exclusive of forms, 35c per cu. ft.; with forms, 60c.

4-inch concrete basement floor

.....12/2c to 14c per sq. ft.

Rat-proofing7/2c

Concrete Steps\$1.25 per lin. ft.

Dampproofing and Waterproofing—

Two-coat work, 20c per yard.

Membrane waterproofing—4 layers of saturated felt, \$4.50 per square.

Hot coating work, \$1.80 per square.

Medusa Waterproofing, 15c per lb., San Francisco Warehouse.

Tricoloc waterproofing.

(See representative.)

Electric Wiring—\$12.00 to \$15.00 per outlet for conduit work (including switches). Knob and tube average \$3.50 per outlet.

Elevators—

Prices vary according to capacity, speed and type. Consult elevator companies. Average cost of installing an automatic elevator in four-story building, \$2800; direct automatic, about \$2700.

Excavation—

Sand, 60 cents; clay or shale \$1 per yard. Teams, \$12.00 per day.

Trucks, \$22 to \$27.50 per day.

Above figures are an average without water. Steam shovel work in large quantities, less; hard material, such as rock, will run considerably more.

Fire Escapes—

Ten-foot galvanized iron balcony, with stairs, \$115 installed on new buildings; \$140 on old buildings.

Floors—

Composition Floors—22c to 40c per sq. ft.

In large quantities, 16c per sq. ft. laid.

Mosaic Floors—80c per sq. ft.

Duraflex Floors—23c to 30c sq. ft.

Rubber Tile—50c to 75c per sq. ft.

Terazzo Floors—45c to 60c per sq. ft.

Terazzo Steps—\$1.60 lin. ft.

Hardwood Flooring (delivered to building)—

3/4x2 1/4" T & G Maple	\$ 88.00 M ft.
1 1/2x2 1/4" T & G Maple	115.00 M ft.
3/4x3 1/2" sq. edge Maple	100.00 M ft.

	3/4x2 1/4" T & G	3/4x2" T & G	3/4x2" Sq. Ed.
Clr. Old. Oak	\$120.00 M	\$ 82.50 M	\$110 M
Sel. Old. Oak	99.00 M	69.50 M	84 M
Clr. Pla. Oak	106.00 M	74.50 M	86 M
Sel. Pla. Oak	97.00 M	62.50 M	76 M
Clear Maple	111.00 M	100.00 M	
Laying & Finishing	14c ft.	12c ft.	10c ft.
Wage—Floor layers, \$10.00.			

Note—Above quotations are all board measure except last column which is sq. ft.

Glass (consult with manufacturers)—

Double strength window glass, 20c per square foot.

Plate 75c per square foot (unglazed) in place, \$1.00.

Art. \$1.00 up per square foot.

Wire (for skylights), 40c per sq. foot.

Obscure glass, 30c square foot.

Glass bricks, \$2.40 per sq. ft., in place.

Note—Above quotations are all board measure except last column which is sq. ft.

Heating—

Average, \$1.90 per sq. ft. of radiation, according to conditions.

Warm air (gravity) average \$40 per register.

Forced air, average \$60 per register.

Iron—Cost of ornamental iron, cast iron, etc., depends on designs.

Lumber (prices delivered to bldg. site).

No. 1 common	\$29.00 per M
No. 2 common	27.00 per M
Select O. P. common	34.00 per M
2x4 No. 3 form lumber	24.00 per M
1x4 No. 2 flooring VG	55.00 per M
1x4 No. 3 flooring VG	47.00 per M
1x6 No. 2 flooring VG	60.00 per M
1 1/2x4 and 6, No. 2 flooring	60.00 per M

Slash grain—

1x4 No. 2 flooring	\$43.00 per M
1x4 No. 3 flooring	40.00 per M
No. 1 common run T. & G.	30.00 per M
Lath	5.25 per M

Shingles (add cartage to price quoted)—

Redwood, No. 1	\$1.10 per bdle.
Redwood, No. 290 per bdle.
Red Cedar	1.10 per bdle.

Plywood—Douglas Fir (add cartage)—

"Plyscord" sheathing (unsanded)	
5/16" 3-ply and 48"x96"	\$30.00 per M
Wallboard Grade (sound one side)	
1/4" 3-ply 48" x 96"	\$37.50 per M
Concrete Form Panels (special core & glue)	
5/8" 5-ply 48" x 96"	\$110.00 per M
If oiled	\$5.00 extra per M

Milwork—Standard.

O. P. \$85.00 per 1000. R. W., \$90.00 per 1000 (delivered).

Double hung box window frames, average with trim, \$6.50 and up, each.

Doors, including trim (single panel, 1 3/4 in. Oregon pine) \$8.00 and up, each.

Doors, including trim (five panel, 1 3/8 in. Oregon pine) \$6.00 each.

Screen doors, \$3.50 each.

Patent screen windows, 25c a sq. ft.

Cases for kitchen pantries seven ft. high per lineal ft., \$8.00 each.

Dining room cases, \$8.00 per lineal foot. Rough and finish about 75c per sq. ft.

Labor—Rough carpentry, warehouse heavy framing (average), \$17.50 per M. For smaller work average, \$35.00 to \$45.00 per 1000.

Marble—(See Dealers)

Painting—

Two-coat work	36c per yard
Three-coat work	50c per yard
Cold Water Painting.....	10c per yard
Whitewashing	4c per yard
Turpentine, 65c per gal., in 5 gal. cans, and 55c per gal. in drums.	
Raw Linseed Oil—97¢ gal. in bbls.	
Boiled Linseed Oil—\$1.00 gal. in bbls.	
Medusa Portland Cement Paint, 20c per lb.	

Pioneer or Dutch Boy White Lead in Oil (in steel kegs). Per Lb.

1 ton lots, 100 lbs. net weight.....	10/4c
500 lbs. and less than 1 ton lots.....	10/2c
Less than 500 lb. lots.....	11c

Pioneer or Dutch Boy Red Lead and Litharge (in steel kegs).

1 ton lots, 100 lb. kegs, net weight.....	10/4c
500 lbs. and less than 1 ton lots.....	10/2c
Less than 500 lb. lots.....	11c

Pioneer Red Lead in Oil (in steel kegs)

1 ton lots, 100 lb. kegs, net weight.....	11/4c
500 lbs. and less than 1 ton lots.....	11/2c
Less than 500 lb. lots.....	12c

Note—Accessibility and conditions cause some variance in costs.

Patent Chimneys—

6-inch	\$1.25 lineal foot
8-inch	1.75 lineal foot
10-inch	2.25 lineal foot
12-inch	3.00 lineal foot

Plastering—Interior—

1 coat, brown mortar only, wood lath.....	Yard \$0.75
2 coats, lime mortar hard finish, wood lath ..	.80
2 coats, hard wall plaster, wood lath.....	.85
3 coats, metal lath and plaster	1.50
Keene cement on metal lath	1.60
Ceilings with 3/4 hot roll channels metal lath	.90

Ceilings with 3/4 hot roll channels metal lath plastered	1.65
Single partition 3/4 channel lath 1 side85
Single partition 3/4 channel lath 2 sides 2 inches thick	1.50
4-inch double partition 3/4 channel lath 2 sides	1.30
4-inch double partition 3/4 channel lath 2 sides plastered	3.00

Plastering—Exterior—

2 coats cement finish, brick or concrete wall	\$1.00
2 coats Galveras cement, brick or concrete wall	1.35
3 coats cement finish, No. 18 gauge wire mesh	1.50
3 coats Galveras white finish, No. 18 gauge wire mesh	1.75

Wood lath, \$7.50 to \$8.00 per 1000.	
2.5-lb. metal lath (dipped)17
2.5-lb. metal lath (galvanized)20
3.4-lb. metal lath (dipped)22
3.4-lb. metal lath (galvanized)28
3/4-inch hot roll channels, \$72 per ton.	
Finish plaster, \$18.90 ton; in paper sacks.	
Dealer's commission, \$1.00 off above quotations.	
\$13.85 (rebate 10c sack).	
Lime, f.o.b. warehouse, \$2.25 bbl.; cars, \$2.15 net, bulk (ton 2000 lbs.), \$1.25 per M.	
Wall Board 5 ply, \$50.00 per M.	
Hydrate Lime, \$19.50 ton.	
Plasterers Wage Scale	\$1.25 per hour
Lathers Wage Scale	1.25 per hour
Head Carriers Wage Scale	1.10 per hour

Composition Stucco—\$1.80 to \$2.00 sq. yard (applied).

Plumbing—

From \$70.00 per fixture up, according to grade quantity and runs.

Roofing—

"Standard" tar and gravel, \$6.50 per sq. for 30 sqs. or over.	
Less than 30 sqs. \$7.00 per sq.	
Tile, \$20.00 to \$35.00 per square.	
Redwood Shingles, \$7.50 per square in place.	
Copper \$16.50 to \$18.00 per sq. in place	
Cedar Shingles, \$8.00 per sq. in place.	
Recoat with gravel, \$3.00 per sq.	
Asbestos Shingles, \$15 to \$25 per sq laid.	

Slate, from \$25.00 to \$60.00 per sq. yard, according to color and thickness.	
Shakes—1x25" resawn	\$1.50 per sq.
1/2x25" resawn	1.50 per sq.
1/2x25" tapered	1.00 per sq.

Sheet Metal—

Windows—Metal, \$1.75 a sq. foot. Fire doors (average), including hardware \$1.75 per sq. ft.

Sightlights— (not glazed)

Copper, 90c sq. ft. (flat).	
Galvanized iron, 30c sq. ft. (flat).	
Vented hip sightlights 60c sq. ft.	

Steel—Structural

\$120 ton (erected), this quotation is average for comparatively small quantities. Light truss work higher. Pil beams and column work in large quantities \$90 to \$100 per ton.

Steel Reinforcing—

\$80.00 to \$120.00 per ton, set.

Stone—

Granite, average, \$6.50 cu. foot in place	
Sandstone, average Blue, \$4.00, Boston \$3.00 sq. ft. in place.	
Indiana Limestone, \$2.80 per sq. ft. in place.	

Store Fronts—

Copper sash bars for store fronts, corner center and around sides, will average 75c per lineal foot. Note—Consult with agents.

Tile—Floor, Wainscot, etc.— (See Dealers) Asphalt Tile—18c to 28c per sq. ft. in stalled.

Wall Tile—

Glazed Terra Cotta Wall Units (single face laid in place—approximate prices)	
2 x 6 x 12	\$1.00 sq.
2 x 6 x 12	1.15 sq.
2 x 8 x 16	1.10 sq.
4 x 8 x 16	1.30 sq.

Venetic Blinds—

40c per square foot and up. Installatic extra.

THE BUILDERS' EXCHANGE OF SAN FRANCISCO STANDARD WAGE SCALE

For mechanics employed on construction work in the Bay Region. Effective September 1, 1937

CRAFT	Journeyman Mechanics
Asbestos Workers	\$ 8.00
Bricklayers (8h-5d)	10.50
Bricklayers' Hodcarriers (8h-5d)	8.00
Cabinet Workers (Outside) (5d)	8.00
Coisson Workers (Open)	6.40
Carpenters (8h-5d)	10.00
Cement Finishers (8h-5d)	10.00
Cork Insulation Workers (8h-5d)	9.00
Electric Workers (8h-5d)	11.00
Electrical Fixture Hangers	8.00
Elevator Constructors	10.40
Engineers, Portable & Hoisting	9.00
Glass Workers (8h-5d)	9.68
Hardwood Floormen	9.00
Housesmiths, Architectural Iron (Shop) (8h-5d)	9.00
Housesmiths, Architectural Iron (Outside) (8h-5d)	10.00
Housesmiths, Reinforced Concrete or Rodmen (8h-5d)	10.00
Iron Workers (Bridge and Structural) Including Engineers (8h-5d)	12.00

CRAFT	Journeyman Mechanics
Laborers, Building (8h-5d)	\$ 6.00
Laborers, Common (8h-5d)	6.00
Lathers, Channel Iron (8h-5d)	9.00
Lathers, All Others	9.00
Marble Setters (8h-5d)	10.50
Marble Setters' Helpers (8h-5d)	5.50
Milwrights	9.00
Model Makers (\$1.50 per hr-h)	9.00
Modelers (\$2 per hr-h)	12.00
Model Casters	7.20
Mosaic and Terrazzo Workers (Outside)	9.00
Painters (7h-5d)	8.50
Painters, Varnishers and Polishers (Outside)	9.00
Pile Drivers and Wharf Builders	9.00
File Drivers' Engineers	10.00
Plasterers (8h-5d)	10.00
Plasterers' Hodcarriers (8h-5d)	7.50
Plumbers (8h-5d)	11.00
Roofers, Composition (8h-5d)	9.00
Roofers, All Others (8h-5d)	8.00
Sheet Metal Workers (8h-5d)	10.00
Sprinkler Fitters	10.00

CRAFT	Journeyman Mechanics
Steam Fitters (8h-5d)	\$11.
Stair Builders (8h-5d)	9.7
Stone Cutters, Soft and Granite (8h-5d)	8.1
Stone Setters, Soft and Granite	12.
Stone Derricksman	9.7
Tile Setters (8h-5d)	11.
Tile Setters' Helpers (8h-5d)	6.3
Tile, Cork and Rubber (8h-5d)	9.6
Welders, Structural Steel Frame on Buildings	11.1
Welders, All Others on Buildings	9.6
Dump Truck Drivers, 2 yards or less	6.1
Dump Truck Drivers, 3 yards	6.3
Dump Truck Drivers, 4 yards	7.1
Dump Truck Drivers, 5 yards	7.1
Dump Truck Drivers, 6 yards	7.1
Truck Drivers of Concrete Mixer Trucks: 2 yards or less	6.1
3 yards	7.1
4 yards	7.1
5 yards	7.1
6 yards	8.1

GENERAL WORKING CONDITIONS

- Eight hours shall constitute a day's work for all crafts except as otherwise noted.
- Plasterers' Hodcarriers, Bricklayers' Hodcarriers, Roofers, Laborers, and Engineers, Portable and Hoisting, shall start 15 minutes before other workmen, both at morning and at noon.
- Five days, consisting of not more than eight hours a day, on Monday to Friday inclusive, shall constitute a week's work.
- Transportation costs in excess of twenty-five cents each way shall be paid by the contractor.
- Overtime shall be paid as follows: For the first four hours after the first eight hours, time and one-half. All time thereafter shall be paid

- double time, Saturdays (except Laborers), Sundays and holidays, from 12 midnight of the preceding day, shall be paid double time.
- On Saturday, Laborers shall be paid straight time for an eight-hour day.
- Where two shifts are worked in any twenty-four hours, shift time shall be straight time. Where three shifts are worked, eight hour's pay shall be paid for seven hours on the second and third shifts, allowing one-half hour for lunch.
- All work, except as noted in paragraph 9, shall be performed between the hours of 8 a.m. and 5 p.m.
- In emergencies, or where premises cannot be vacated until the close of business, men than

- reporting for work shall work at straight time. Any work performed on such jobs after midnight shall be paid time and one-half up to four hours of overtime and double time thereafter, provided that if a new crew is employed on Saturdays, Sundays or holidays which he not worked during the five preceding days such crew shall be paid time and one-half.
- Recognized holidays to be: New Year's Day, Decoration Day, Fourth of July, Labor Day, Admission Day, Thanksgiving Day, Christmas Day.
- Men ordered to report for work, for whom no employment is provided, shall be entitled to two hours' pay.

MODERNIZED PRODUCTS

Brief Notes on New Materials and Equipment in the Building Industry.

122. HARDWARE CASTINGS

The New Jersey Zinc Company's booklet illustrating their zinc alloy die castings in hardware appears to be a very interesting one and should prove useful to those interested in hardware.

123. 24-HOUR CEMENT

"When Minutes Mean Dollars" is the title of a very attractive manual just issued by the Pacific Portland Cement Company. This booklet illustrates the use of 24-hour cement and tells just where and when it should be specified. Send for your copy.

124. METAL LATH

A small news magazine, printed by the Metal Lath Manufacturers Association is full of timely information on metal lath and the progress of this industry in modern building. Leading metal lath and steel companies are contributors.

125. CONCRETE

The Portland Cement Association has issued a splendid new booklet which they have called "Architectural Concrete." This is the third number and contains some excellent material.

126. VALVES

A new catalog on Valves has just been issued by the Automatic Switch Company. Prices, descriptions and discounts are listed. Send for a copy by clipping the coupon.

127. COPPER BULLETIN

Copper and Brass Research Association has issued another of its excellent bulletins. These always contain pertinent information.

128. MAGAZINE

National Lead puts out this month a "Dutch Boy Quarterly." This page has featured the monthly magazine of the same name and again welcomes its periodical appearance. Send for your copy.

129. REDWOOD

The California Redwood Association has a new booklet which should prove of great interest. They call it "Styling Your Home." There are a number of planned houses, all showing the various interesting uses of California redwood.

130. WESTBOARD

In a broadside issued by the Washington Veneer Company there is illustrated an unusual product "Embossed Westboard." The coupon will bring you a copy of this sheet descriptive of an interesting product.

131. HEATING

John J. Nesbit Inc., have issued an illustrated booklet of their extended copper heating surface material. Included are tables of temperature and condensation rates.

132. LUMBER

The Durable Woods Institute has prepared a very fine little booklet on the use of lumber in building. Clip the coupon for your copy.

133. WALL UNITS

The Clay Products Institute of California has just issued a very attractive new booklet on "Terra Cotta Wall Units." This is a well arranged booklet and contains some excellent material with illustrations.

134. LUMINALL

Outside Luminall, a new product manufactured by the National Chemical and Manufacturing Company, is illustrated in a broadside recently issued. Send for your copy by using the coupon.

135. BUILDING PRODUCTS

The Allegheny Steel Company and

The Ludlum Steel Company, two old and well established companies, have merged and have issued a brochure illustrating their combined building products. The title is particularly appropriate, "Twin Engineered For Progress." Send for your copy.

136. ALUMINUM

"Window Sills and Copings of Alcoa Aluminum" is the title of a very fine little booklet issued by the Aluminum Company of America. It ably illustrates the use of aluminum for this important feature of modern buildings.

FREE FOR THE ASKING

Check items on coupon, paste on letter head or postal card, and mail to Architect and Engineer.

Architect and Engineer
68 Post Street
San Francisco, Calif.

Please send me literature on the following items as checked below. This request places me under no obligation.

122 <input type="checkbox"/>	129 <input type="checkbox"/>
123 <input type="checkbox"/>	130 <input type="checkbox"/>
124 <input type="checkbox"/>	131 <input type="checkbox"/>
125 <input type="checkbox"/>	132 <input type="checkbox"/>
126 <input type="checkbox"/>	133 <input type="checkbox"/>
127 <input type="checkbox"/>	134 <input type="checkbox"/>
128 <input type="checkbox"/>	135 <input type="checkbox"/>
	136 <input type="checkbox"/>

My Name _____

Name of Company _____

Street _____

City _____ State _____

New Standard Specifications For Gypsum Plastering

The American Standards Association has recently approved as an American Standard new specifications for gypsum plastering and lathing, which were sponsored by the American Society for Testing Materials and the American Institute of Architects. The specifications represent the first American Standard on these subjects.

The specifications are divided into two chapters: the first covering the specifications for gypsum plastering; and the second, lathing. Preceding the specifications are some general notes on plastering, calling attention to the use of the best practices in all operations connected with plastering, with particular emphasis on the following:

- (a) Since dirty plastering tools accelerate the setting of plasters, they must be kept clean.
- (b) The water used in mixing plaster must be clean, free from salt, alum and organic or vegetable matter. Water containing salt and alum or in which tools have been washed accelerates the set of plaster too much, while water which contains organic or vegetable matter may retard its set.
- (c) Attention is next directed to the use of sand that is well graded from fine to coarse and to the fact that too much sand weakens the plaster.
- (d) Since the drying of plaster is so important in obtaining a good plastering job, a comprehensive statement is included regarding this, which reads:

"A portion of the water used for mixing plaster is necessary for the chemical reaction which sets and hardens plaster. Therefore, plaster must not be permitted to dry out before setting has taken place. It must be protected from blasts of wind and from drying unevenly or too rapidly. If glazed sash are not in place and it is necessary to enclose building, exterior openings of building should be screened with cheese cloth or similar material. In cold, damp, or rainy weather, properly regulated heat must be provided, but precautions must be taken against too rapid drying before set has occurred. As soon as the plaster has set, free circulation of air shall be provided to avoid sweat-outs. Continue heating after plaster has set, to insure as rapid drying as possible. Plaster must not be allowed to freeze before it has set. Alternate freezing and thawing must be avoided.

The chapter on plastering is divided into ten sections with the following titles: I. General Provisions; II. Scope of Work; III. Materials; IV. Plaster Mixes; V. Mixing and Preparation; VI. Finishes; VII. Thicknesses of Plaster; VIII. Preparation For Plastering; IX. Application; and X. Acoustical and Other Special Purpose Plasters.

The first two sections cover the usual provision applicable to all specifications. Chapter III, Materials, requires materials used in plastering to comply with their respective A.S.T.M. specifications. All manufactured materials are required to be delivered in original packages, containers or bundles, bearing the manufacturer's and brand names. Also, plaster and other cementitious materials are required to be kept dry until ready to be used; they must be kept off the ground, under cover, and away from sweating walls or other damp surfaces.

Section IV. Plaster Mixes, includes the requirements for mixing sand with gypsum neat plaster and gypsum wood fiber plaster; sand is added to the latter plaster only when it is applied on masonry surfaces (other than monolithic concrete) and the proportions are one part wood fibered plaster to one part sand, by weight. The term "neat" as applied to gypsum plaster means that the material, as shipped by the manufacturer, does not contain sand. Sand must be added at the job.

The amount of sand added to "neat" plaster for the first coat on all types of lath is not to exceed two parts to one part of plaster, by weight. For the first coat on masonry surfaces (except monolithic concrete) and for all second coats in three-coat work, the proportion is one part "neat" plaster to not more than three parts sand, by weight.

Instructions for hand and mechanical mixing are contained in Section V. In the preparation of lime putty used in Gypsum Lime-Putty Trowel Finish and in Keene's Cement Finish Coats, quicklime, if used, is required to be thoroughly slaked, allowed to cool, and then let stand for not less than 24 hours. Hydrated lime must be soaked for 24 hours. All lime putty is required to be kept moist until used and screened through a No. 10 sieve.

The proportioning and mixing of finish coats are covered in Section VI. Included in the finishes are Prepared Gypsum Trowel; Prepared Gypsum Sand Float; Gypsum Sand Float; Gypsum Lime-Putty Trowel; Keene's Cement-Lime Sand Float; and Colored Finishes for float and texture work.

Section VII is a very important one, having to do with the Thicknesses of Plaster, which are required to be not less than the following, measured from the face of the plaster base to the finished plaster surface. Adequate thicknesses of plaster are necessary to obtain strength, resist cracks, and supply fire-resistance:

- | | |
|---|------------------------------|
| (a) Lath—Metal, Wire Lath and Wire Fabric | 5/8" minimum |
| (b) Lath—All other types | 1/2" minimum |
| (c) Unit Masonry and Concrete Walls | 5/8" minimum |
| (d) Monolithic Concrete Ceilings | 1/8" minimum
3/8" maximum |

In connection with item (d), the specifications state that monolithic concrete ceiling surfaces requiring more than 3/8" of plaster to produce desired lines or surfaces shall have metal or wire lath attached to them.

Further, the attention that has been given to plastering on monolithic concrete surfaces, ceilings, or walls, is indicated in the following paragraph:

"Concrete surfaces which are to be plastered should be rough. The desired character of surface may be procured by using rough forms which have not been oiled or greased, or by hacking or bush-hammering the surface to be plastered after the forms are removed and before the concrete has

become too hard or by applying a dash coat of Portland cement grout."

Section VIII. Preparation for plastering, specifically provides that plaster shall not be applied to surfaces containing frost; that a minimum temperature of 40° F. shall be maintained in a building for an adequate period prior to application of plastering, while plastering is being done, and until it is completely dry; and that adequate, properly regulated ventilation be provided.

Masonry surfaces on which suction must be reduced are required to be properly wet down immediately before plaster is applied, particularly so if wood fiber gypsum plaster is used. Wood lath must be thoroughly wet down from 12 to 24 hours before plaster is applied and in very dry weather a second wetting is required from 1 to 3 hours before plastering. Gypsum and fiber insulation lath shall not be wet down.

Section IX. Application, is sub-divided into two main parts, Base Coats and Finishes. Under the first part, detailed specifications are given for applying two-coat and three-coat work, and the plastering of solid partitions and plastering on monolithic concrete. The proper method of applying the finish coats, previously referred to, is given in the latter part of the section.

Acoustical and other special purpose plasters (Section X) are required to be mixed and applied in accordance with the manufacturer's directions.

The second chapter of the specifications deals with lathing exclusively, containing specifications for gypsum lath, wood lath, fiber insulation lath, metal lath, wire lath, paper-backed wire fabric, metal accessories, and channels. The erection of the different type laths is covered in Section II of this chapter. Special subdivisions under Section II give the methods for constructing and erecting ceilings composed of metal hangers, runners and cross-furring to which lath is applied; steel studs for solid plaster partitions; and metal wall furring.

Arrangements are now being made for printing these specifications. Those desiring copies can obtain them gratis by applying to the Gypsum Association, 211 West Wacker Drive, Chicago.

GLASS INSTITUTE COMPETITION

Eight men from various parts of the globe, whose interests cover a wide range in the fields of architecture, design and decoration, will be judges of exhibits submitted in the Pittsburgh Glass Institute Competition for 1938. The competition, open to all architects, decorators, designers and home owners, closed November 1 and the jury will announce its decision shortly. The following men will chose the winners for forty cash prizes, totaling \$3,600, and the thirty-nine medal awards: William Lescaze, New York architect; Albert Kahn, Detroit architect; William Kimbel, New York decorator; Raymond Loewy, New York designer; Alfred Phillips Shaw, Chicago architect; Paul R. MacAlister, New York decorator, and Gardner A. Dailey, San Francisco architect.

MANSION OF AN ECCENTRIC

From Kernersville, N.C., comes the following: As the natives some sixty years ago viewed the construction of J. Gilmer Korner's house, they whispered to one another that it was sheer folly to build such a structure. Korner, eccentric artist and world traveler, delighted at the term, put "Korner's Folly" in tile before his new house, and from that day to this it has had no other name.

He never bothered to explain, but there was method in Korner's madness, just lately revealed by his daughter, Mrs. D. L. Donnell, who now owns Korner's Folly. In addition to his other talents (he made his fortune painting the famous Durham Bull all over the world) Korner was a decorator. His new home was intended to be a sample of his decorating repertoire.

But to the awe-struck natives, there was plenty of evidence to support their grim judgment. The house is five stories high, and most of the 22 rooms are on different levels, necessitating a maze of stairways. Some ceilings are 25 feet high, some less than six feet. Each of the four sides has its "own front door," the designer refusing to slight any side of his home.

Korner liked to indulge his whims and opinions. He wanted to shingle his house with wood of a single giant tree. The owner refused to sell the tree, so Korner bought his entire plantation to get his shingles. Hand-made bricks are of eight varieties, created by Korner himself, who failed to leave behind the secret formulas he used.

The first little theater auditorium in the South was built on the fifth floor. There, Mrs. Korner introduced amateur theatrics to a community which vaguely considered the theater an especial instrument of the devil.

From his travels, he furnished Folly with murals, silk and tapestry panels and mirrored walls. Much of his teakwood furniture was personally designed, and includes such novelties as a lover's seat built for three—including the omnipresent chaperone. However, Korner indulgently included "lover's nooks" and "witches' corners" for the young people who visited the house.

Because of the difficulty of heating the Folly (it has 22 stoves for its 22 rooms), the house is unoccupied. However, still furnished, it is open at regular intervals, and attracts both those curious to see its oddities and those interested in the artwork created by foreign artists who were brought to the Folly to decorate the home.

GOLD MEDAL

Dr. Frank Baldwin Jewett, a native of Pasadena, vice-president of the American Telephone and Telegraph Company and president of the Bell Telephone Laboratories, has been awarded the 1939 John Fritz Gold Medal, highest of American engineering honors, for "vision and leadership in science, and for notable achievement in the furtherance of industrial research and development in communication."

SOUTHERN CALIFORNIA CHAPTER

At the October meeting of Southern California Chapter, A. I. A., publicity and advertising practices by individual architects and a program of institutional publicity were the subjects under discussion.

The speakers included Samuel E. Lunden, Gordon B. Kaufmann, Ralph Flewelling, S. B. Marston, David J. Witmer, Edgar Bissantz and several other architects, most of whom favor a publicity program. A resolution was adopted authorizing the appointment of a special committee to report on the matter.

Earl Heitschmidt, chairman of the legislative committee, reported on a proposed amendment to codification of existing state laws which contemplates, among other things, creating one board of architectural examiners to replace the two existing boards. The new board would consist of five members and would have broader regulating powers.

A proposed amendment to the state Civil Service Act, which, if passed by the legislature, would require that it be placed on the ballot, was also reported on by Mr. Heitschmidt. The amendment would change the existing act which makes it necessary, with certain exceptions, to have all state services rendered by civil service employees in state service.

Support of the members in underwriting initial costs of publishing the Chapter book, "Residential Architecture of Southern California," was requested by Paul Robinson Hunter. The book will consist of a number of photographs and plans of residences that received Chapter honor awards last year.

The current honor awards program was reported on by Wm. H. Harrison, chairman of the committee in charge. Time for presenting the photographs, which are to be non-residential in character, was extended to November 1.

New junior associate members of the Chapter were introduced by Carleton M. Winslow. They are: Kenneth Acker, Stanley R. Gould, James R. Moreland, Jr., Griswold Rætzte and Savo Stoshitch. Stanton Willard of Bakersfield, who has transferred from the Northern California Chapter, was also introduced.

Vice-president Samuel E. Lunden, who presided at the meeting, stated that nomination of officers and directors for the coming year would take place at the November meeting of the Chapter.

OREGON CHAPTER ACTIVITIES

A well attended meeting of Oregon Chapter, following the summer vacation, was held at Hilaire's restaurant, Tuesday, September 20.

Those present were Messrs. Howell, Jones, Heiler, Johnston, Schneider, Aandahl, Morin, Parker, Doty, Brookman, Jacobberger, Herzog, M. Fritsch, Turner, Schmeer, B. Smith, Hartford, I. Smith, Bear, Forrest, Morden, Butcher, Zeller. Guest, John Annand.

Minutes of the June meeting read and approved.

Messrs. Schneider and Morin reported on membership, several new applications having been received.

Mr. Jacobberger reported for Industrial Relations Committee on meeting at Labor Temple for stimulating new construction.

M. Fritsch reported for Stanton (Publicity) on new home series to be run in the Farm and Home section of the Sunday Oregonian. The Oregonian requests the Chapter to cooperate and promises an exclusive series if this is done.

Mr. Morin reported on proposed East Side Market Housing Exhibit to be held in December. Chapter has promised cooperation.

The meeting approved a motion that a joint meeting of the Oregon and Washington Chapters be held at Timberline Lodge, November 5th, and that the California Chapters also be invited to attend.

The following committee was named to take charge of arrangements: Messrs. Crowell, Schneider, Dukehart, Morin and Margaret Fritsch.

Mr. Jacobberger pugnaciously brought up the U. S. Government's Postoffice Competition question again. After considerable discussion the matter was tabled.

At the October 18th meeting the November outing at Timberline was further discussed.

Correspondence with Seattle in reference to joint meeting was read and started considerable discussion. There being only six \$5 double-bed rooms, all were reserved for Washington delegates. Bunks being \$2 and twin-bed rooms \$3 per person; the secretary was instructed to send out return postcards for reservations. Washington Chapter notified that at least 40 will come from Seattle, Tacoma and Spokane, including Messrs. Priteca, Holmes, Aiken, Maloney, Jones, Bain, Stoddard, Gowan, McClellan, Naramore, Alden, Thomas, Gove, Mock, Morrison, Pearson, Shay, Fey, Jacobsen, Sherrett and Osterman.

Mr. Johnston replaces Mr. Hemenway (whose term expired in September) as chairman of Highlands Committee.

Mr. Crowell having left earlier in the evening, a motion was made and seconded and unanimously carried that the Oregon Chapter petition the Institute Board of Fellows that (because of his outstanding work in behalf of the Institute and Chapter during the past ten years) Wm. H. Crowell be elevated to Fellowship.

Reference was made to the inclusion of a new firm name in the classified section of new phone book under "Architects," one member not being an architect at all and the other not registered in this state. Secretary Fritsch of the State Board reported similar infringements in Salem and Marshfield, with no cooperation from the Telephone Company. The secretary was instructed to write a protest to I. D. Winslow, district commercial manager, and send copies to the State Board and to Clyde Foley, secretary of Oregon Pro-

Professional Societies, as similar lapses were reported among doctors' and lawyers' listings.

On motion by Herzog and carried, the secretary was instructed to write a letter of condolence to the family of Michael Reuter.

The question was raised as to F. D. Roosevelt's qualifications as an architect and reference to Life's 8-houses, all of which moved the Chapter to adjourn at 9:30.—R. L. M.

S. F. RAILWAY TERMINAL

With practically all work completed on the San Francisco-Oakland Bay Bridge electric railway terminal, work on the interior finish of the structure is rapidly being pushed to completion. This work includes the placing of a finish coat at the track level, wainscot painting, and enameling. Completion of the terrazzo floor on the mezzanine of the center unit was under way, with the tile setting for the walls of the east and west units continued. Benches are being placed in the waiting rooms of the street floor, with a general cleanup throughout the building under way.

Third rail has been installed for the tracks at track level. On the viaduct, over which trains will ply from the bridge to the terminal structure, track work and catenary stringing operations are well under way.

All structural work on the bridge proper for the interurban system has been completed.

Meanwhile, Southern Pacific (Interurban Electric) trains have been running nightly over the east end of the bridge for the purpose of instructing engineers in the new signal system adopted for the bridge railway.

Trains are expected to be in operation over the Bay Bridge after the first of the year.

UPWARD-ACTING GARAGE DOOR

The availability of a new, improved and foolproof upward-acting garage door which is priced for the volume low-cost building field, is announced by Henry Siess, president of the Crawford Door Company, Detroit, Michigan, holders of the patents on the new door and manufacturers of the hardware unit. This garage door will be marketed through millwork distributors, lumber dealers, and the outlets of the Crawford Door Company.

The following manufacturers of fir doors have been licensed by the Crawford Company to provide the prefitted and factory-drilled fir door units and to sell the complete Craw-Fir-Dor: Buffelen Lumber and Manufacturing Company, Tacoma, Washington; Central Door and Plywood Corporation, Portland, Oregon; Clear Fir Lumber Company, Tacoma, Washington; Harbor Plywood Corporation, Hoquiam, Washington; M and M Wood Working Company, Portland, Oregon; Monarch Door Company, Tacoma, Washington; Northwest Door Company, Tacoma, Washington; Robinson Manufacturing Company, Everett, Washington; and, Wheeler-Osgood Sales Corporation, Tacoma, Washington.



Specify
CONDITIONED AIR HEAT
with the **DELCO CONDITIONAIR**
Product of General Motors

• The Delco Conditionair automatically heats, humidifies, filters, circulates healthful air throughout the home. Many exclusive features that contribute to greater economy and durability. Models for oil or gas. Get all the facts.

ALADDIN HEATING CORPORATION

Delco-Frigidaire Dealer

2222 SAN PABLO AVENUE • OAKLAND

JOHNSON

Since 1904, the name of Johnson on an oil burner has been accepted as the seal of fine engineering, skilled craftsmanship and dependability. Johnson Burners on an architect's specifications insure satisfaction and comfort for the home owner. Johnson builds oil burners for every need of industry, commerce and home. Data sheets on each type of Johnson Improved Burners give complete information and specifications. Johnson engineers will be glad to assist in preparation of layouts & estimates.



THERE'S A JOHNSON OIL BURNER FOR EVERY PURPOSE

AIR-CONDITIONING? See the Johnson SELECTAIR, a compact, efficient unit which offers every desired feature for economical heating, air-conditioning and ventilating the home. With year-round domestic hot water. Oil-fired by the Johnson Pressure-type "Bankheat" Burner.

BOILER-BURNER UNIT? Test the "LADDI DU-ALL", a compact and completely automatic unit furnishing heat and hot water for small and medium-sized homes and apartments at low initial cost.

... Descriptive bulletins on request.

S. T. JOHNSON CO.

940 ARLINGT^C 4, OAKLAND, CALIFORNIA
401 N. BROAD STREET, PHILADELPHIA PA.

SHALL WE HAVE AN ARCHITECT?

This question arises in the minds of people deciding to build, early in their planning.

The majority do eventually decide to spend a fair proportion of their building money for this service instead of using that money for some of the things they would like in the house. They come to that decision because they want the expert knowledge of the architect to insure their getting as near perfect living conditions as they can arrive at.

One of the major services in 24-hour demand in any modern home is electricity—and every indication points to a progressively increasing demand in the next few years.

If the house is to provide modern standards of comfort and convenience the electrical wiring must have careful consideration at the time the house is built. That is one of the major purposes the client has in mind when he engages the services of an architect, and failure of the system to give efficient service reflects discredit on the architect's abilities.

Red Seal specifications furnish a sound minimum basis from which to work. They are free for the asking. Wiring advice and consultation also without cost or obligation.

PACIFIC COAST ELECTRICAL BUREAU

447 Sutter Street

SAN FRANCISCO

• CALIFORNIA

601 W. 5th Street

LOS ANGELES

MODEL HOTEL ROOM AT FAIR

A "contemporary" hotel room, designed and decorated by Holabird & Root, one of America's foremost architectural firms, will be included in the Decorative Arts Exhibit of the 1939 Golden Gate International Exposition.

Holabird & Root have been pioneers in the revolt against the drab monotony of the average hotel room, and have executed a number of commissions combining beauty, comfort and current interior decorations into the decorative scheme of their rooms.

This progressive Chicago firm believes that "planning is more than an arrangement of rooms in a serviceable order. It is the coordination of every part and aspect of a building, its site, its structure, its equipment, its furniture, and furnishings, and through those, all that goes on within each particular building."

Their ideas of the "contemporary" trend in architecture and interior design sum up "what the Greeks did 2500 years ago, what the Swedes have been doing for decades, and what a few American architects are doing now."

Among the Holabird & Root buildings are the U. S. Forest Products Laboratory in Madison, Wisconsin, the Board of Trade Building, Palmolive Building, Daily News Building in Chicago, the Field House at the University of Chicago, and a group of fraternity houses at Northwestern University. The Chrysler Exhibition Building at "A Century of Progress" Chicago Fair was also designed by Holabird & Root.

The Decorative Arts Exhibit at the Golden Gate International Exhibition will be "contemporary" in its theme. It will have the center space in one of the permanent Treasure Island hangars which is being used as a Fine Arts Palace during the duration of the Fair, and will be surrounded by various art sections devoted to the old masters, Pacific Basin arts, and contemporary American and European art displays.

Artist-craftsmen of top rank will come to the Exposition to arrange the chief ensemble of twelve completely furnished rooms. They will include Mies von der Rohe, formerly of Germany, Aalto of Finland, LeCorbusier of France, and McMillan of this country.

WORLD'S LARGEST CASH REGISTER

As visitors enter the grounds of the New York World's Fair 1939, their passage through the gates will be "rung up" on the largest cash register ever built.

The cash register, which is now under construction, is 40 feet 6 inches in height and is mounted on top of the company's centrally-located exhibit building in the amusement area. The register will revolve so that the figures it records—figures six feet high and 74 feet up in the air—may be visible from practically all parts of the fair grounds. Besides the daily attendance, the steadily-mounting "total attendance to date" will be tabulated as the season wears on.

STRUCTURAL ENGINEERS' CONVENTION

The lovely El Encanto Hotel, Santa Barbara, Frank J. McCoy, owner and manager, was the meeting place of the Structural Engineers Association of California for their annual convention, November 4-5.

Mayor Patrick J. Maher of Santa Barbara, welcomed the delegates and commended the engineering profession for their service to the state in the design of great bridges and structures which were accepted and used by the public with unquestioning confidence.

Professor F. J. Converse of California Institute of Technology and President of the Association, presided.

Papers were read by members based on scientific research and study. In the field of wood and timber design and construction, R. S. Chew, E. D. Seaver, T. C. Combs, A. C. Horner, Albert Creal, and Harry Bolin made important contributions. New developments in steel piling were discussed by J. H. Davies, Milo S. Farwell, and George Whittle.

Mark Falk presented a paper covering the use of various types of concrete piling. George Housner discussed recent developments in concrete, while Harold Roach noted the many tests being made at various universities in connection with steel and steel construction. William Moor's paper dealt with sub-surface soil investigations through pre-piling method.

W. E. Prine, editor of Southwest Builder and Contractor, presented an interesting paper on "The Construction Industry Perspective," and R. R. Martel, professor of structural engineering, California Institute of Technology, gave a history of engineering schools and education.

The following registered from Northern California: J. E. Mackie, W. E. Emmett, H. M. Engre, H. B. Hommill, Milo S. Farwell, H. A. Schirmer, Will G. Corlett, Mac D. Perkins, F. P. Ulrich, Wm. H. Popert, A. V. Saph Jr., George Washington, H. Rosenthal, A. C. Horner, M. C. Paulson, Frank A. Johnson, Harry W. Bolin, Henry D. Dewell.

The Southern delegates included J. E. Shield, S. F. Bamberger, Wm. W. Moore, J. H. Davies, Paul E. Jeffers, Ford J. Twaits, R. V. Labarre, C. J. Derrick, F. J. Converse, R. J. Hiller, Murray Erick, Mark Falk, R. W. Binder, Blaine Noice, Geo. J. Fosdyke, C. Makutchan, Donald F. Shugart, W. E. Wilson, E. Maag, P. A. Horn, J. G. Middleton, Clyde N. Dirlam, Walter Putnam, Stanley Burne, R. McC Beanfield, D. L. Narver, C. L. A. Bokemohle, James R. Bole, J. E. Byers, Wm. M. Taggart, Wm. D. Greenlee, C. D. Wailes, Steve Barnes, R. R. Martel, T. C. Combs, Geo. Housner, A. Creal, R. J. Kadow, Jack Sparling, Harold Roach, Joseph Sheffet, A. M. McConnell, Milton W. Nigg, Ellis W. Taylor, E. D. Seaver, Ben Benioff, D. R. Edwards.

Next year's convention will be held in the North, probably in San Francisco so that the visitors may enjoy the Treasure Island Exposition.

ANNOUNCING "ALUMILITE" ALUMINUM VENETIAN BLINDS

The Only Window Insulation
in the World

**SUPREME LIGHT CONTROL
NOW
EXCLUSIVELY IN CALIFORNIA**
by

MacDONALD 
HARDWARE MANUFACTURING CO.

YUkon 0123

963 Harrison St.

San Francisco

"Goods of the Woods"

**Dependable
Building
Materials**

Lumber and Millwork

for

All Types of Construction

★

**Wolmanized or Creosoted
Lumber and Timbers
is your protection against
Termites and Decay**

★

E. K. WOOD LUMBER CO.

San Francisco

Los Angeles

Oakland

"OUR ARCHITECT SAID..."



OF COURSE you can specify your own water heater, but you're paying for my years of experience and I want to see you get the best, particularly when it costs you no more. I have been specifying DAY and NIGHTS for more than 20 years; they have patented features that will save you a lot of money during their years of faultless operation. I don't believe there's any question about the fact that they are truly America's finest water heaters!

INTERESTING PICTURE BOOK FREE

Spring Eyington and Jed Prouty (shown above) with the entire famed "JONES FAMILY" of 20th Century-Fox depict the many advantages of DAY and NIGHT hot water in an interesting booklet that we'll be happy to send you.

DAY and NIGHT WATER HEATER COMPANY
MONROVIA, CALIFORNIA

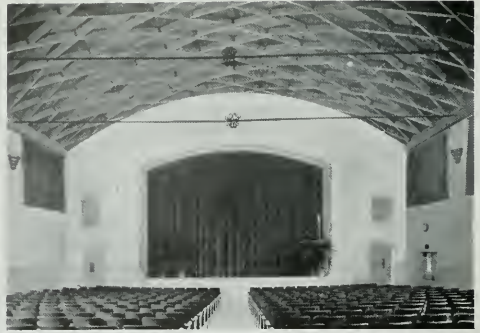

MARSH, SMITH & POWELL USE LAMELLA

The World's Finest Wood Roof

Pictured above: Lamella roofed auditorium, Sierra Madre High School in Southern California. This is only one of many Lamella roofs designed and constructed by Summerbell Roof Structures for Marsh, Smith and Powell on different types of buildings. Every Architect recognizes the beauty and adaptability of the Lamella roof. Every Engineer knows it is the strongest, safest, structural wood roof built.



SUMMERBELL ROOF STRUCTURES

SEATTLE : PORTLAND : OAKLAND : LOS ANGELES : PHOENIX



**RUSSWIN
LOCKS**



for
all

buildings



Please call us for help
on Specifications and
Estimates.

**BENNETT-MONTGOMERY
HARDWARE CO.**

Telephone - - TR. 5726

LOS ANGELES

323-327 South San Pedro Street

**Pressure
Treated Lumber?**

Specify

BAXCO CZC

**"Chromated Zinc
Chloride"**

**Protects against decay
and termite attack**

*Available for prompt shipment
throughout California*

J. H. BAXTER & CO.

601 W. 5th Street
LOS ANGELES
Phone Michigan 6294

333 Montgomery Street
SAN FRANCISCO
Phone DOuglas 3883

THE TROUBLE WITH MODERN HOUSING

Economic as well as social objectives demand eradication of slums, Frederick Bigger of the Pittsburgh Chapter of the American Institute of Architects, chairman of the Pittsburgh City Planning Commission, declares in a report on the basic difficulties of American housing.

A municipality, in preserving a "dangerous and pathological" housing condition and at the same time attempting to compensate for it by vast expenditures for new projects, was likened by Mr. Bigger to "a mad physician" who administers poison and antidote, toxin and anti-toxin, in concurrent doses.

"Our communities, generally, have seemed to be unable or unwilling, or both, to prevent wholesale retrogression," says Mr. Bigger, whose report appears in a social study of Pittsburgh, published by the Columbia University Press. "The actual situation, when analyzed in the light of an observable drop in living standards, reveals that there is an excess of inferior dwellings, a lack of social control to prevent overcrowding and the occupancy of undesirable structures, and a real shortage of good houses.

"Clearly, the continuance of substandard housing in the urban picture is a principal cause of new housing developments which force the community to expand over wider territory, to become physically difficult to administer, costly to repair, and extravagant to operate. In these trends, with their collectively unsound economic basis, is to be found the obvious explanation of the disconcerting fact that the larger the community, the greater the per capita cost of operating it.

"In the trend toward better housing—accelerated in prosperity and halted or reversed in times of depression—the dominant factor unfortunately is not the well-being of the people who are housed, it is the pressure exerted by our financial procedure and its objective—as much profit as we can get. This is buttressed by unwieldy legalities.

"The pressure of financial factors affecting housing—and building generally—compels an unremitting search for economies in planning and construction. A premium is placed upon ingenuity as an aid in 'beating the game' which is so inflexibly fixed by the financial set-up. Among the results of such efforts are increasing skill in site-planning, in the grouping of buildings, and in the creation of more adequate and appropriately designed open spaces.

'Less effort, or less successful effort, has been directed to the search for a way to escape the maladjustments which our traditional practices involve. The thing we should be looking for is a better and more equitable adjustment between two forces which now pull in opposite directions. They are, on the one hand, the interest and aim of the private property owner; and, on the other hand, the interest and aim of the collective group of private property owners who make up a dominant part of the community and whose col-

No Worry for the Architect

"— All acid proof drain pipe and fittings shall be ferro-silicon CORROSIRON —"

[Write for this specification]



FEDERAL BUILDING • CIVIC CENTER • SAN FRANCISCO

Arthur Brown, Jr., Architect

CORROSIRON DRAIN LINES and FITTINGS and LABORATORY EQUIPMENT was specified because of its superior resistance to corrosion and wear.

Pacific Foundry Company, Ltd.

NEW YORK • 3100 NINETEENTH ST., SAN FRANCISCO • LOS ANGELES

BUILD WELL

A PROPERLY designed and well constructed building is a credit to any city and a profitable investment for its owner.

Such structures are the STANDARD OIL BUILDING, MATSON BUILDING, FOUR-FIFTY SUTTER STREET, STOCK EXCHANGE, S. F. BASE BALL PARK, MILLS TOWER, OPERA HOUSE and VETERANS' MEMORIAL, San Francisco, OLYMPIC CLUB ALTERATIONS, SANTA ANITA RACING PLANT and other notable structures — all built or supervised by —

Lindgren & Swinerton, Inc.

Standard Oil Building 605 W. Tenth Street
San Francisco Los Angeles

We Maintain a Termite Control Department

POMONA TILES

FOR
Bathrooms and Kitchens
in over 60 colors

Warehouses and Display Rooms

135 Tenth St. San Francisco
629-33 North La Brea Ave. Los Angeles
6106 Roosevelt Way Seattle

POMONA TILE MFG. CO.
PLANT — POMONA, CALIF.



Write for "The Charm of a Well Lighted Home" — to help you plan attractive and efficient lighting.

Plan your lighting when you're planning. Incandescent provides ideas for any decorative effect in beautiful traditional and contemporary lighters wrought for a lifetime of perfect lighting.

INCANDESCENT SUPPLY CO.

SAN FRANCISCO : OAKLAND : FRESNO : LOS ANGELES

HARER GAS FURNACES HEAT

Consult us for the answer to your problems

HARER-PERRY COMPANY

5662 Keith Ave., Oakland, California

Phone HUmboldt 7928

A Permanent Exposition
of the newest ideas
in home planning
and equipment.



THE BUILDING MATERIAL EXHIBIT

Architects Bldg. • Fifth & Figueroa • Los Angeles • MU-6306

lective action is exercised by their chosen public officials.

"Whether the private owner of property be an owner-occupant of a dwelling or a landlord, he is dominated by the profit motive. He objects to increased taxation, but he desires the improvements, at public expense, which promise to make his property more valuable.

"Acting collectively with his fellows, through public officials, he finds that he has to pay outrageous prices for the land or buildings that must be taken from John Doe or Richard Roe to make way for a public improvement. Still acting collectively, he finds it too costly to buy the private property necessary for the recreation of his children, as a substitute for the private yard play space that has been covered over by 'more profitable' buildings."

Public improvement such as a costly street widening is followed, Mr. Bigger points out, by the expanding cycles of higher property values, higher taxes, more bulky buildings, more intensive use of private property, more people and vehicles in the street, demand for relief from congestion, specific proposals for new public improvements, new improvements at public expense, increased property values, still higher taxes, still more intensive use of private property, still more 'congestion' of people and vehicles in the street, demands for still more 'relief from congestion', new schemes proposed to increase values, another publicly financed improvement program, and so on.

"All through this vicious spiral the public treasury never comes out ahead, its credit becomes pledged to the limit; some property owners are more or less constantly 'on the make', other owners have nothing done to help their own properties the while they contribute taxes toward this effort to increase the values of the favored owners' property.

'Public facilities—streets, sewers, water, lights, etc.—which serve the blighted area and the slum have to be maintained after a fashion, at least, by public funds. They may, or may not, have been adequate when first supplied; but they are almost certain to be neglected after decline has set in, thus accelerating retrogression.

"If, however, standard maintenance of these facilities should be continued, either the tax contribution of depreciated properties is less than the cost of the service they enjoy, or they must be overcrowded to produce sufficient revenue to meet such a charge. Whether or not the blighted area and the slum pay for their own facilities, it is a theoretical fiction that they contribute their proper quota toward the provision of facilities for other and higher-standard localities, perhaps even for those new ones in which modern housing is set up to compete with them.

"Is there an alternative to saddling high-standard housing and non-residential properties with the cost of maintaining even inferior public services for blighted areas and slums which cannot pay for them? In effect

the municipality does two ridiculously contradictory things; that is, it preserves a dangerous and costly pathological condition and at the same time attempts to compensate for it by vast expenditures for new projects. It is as if a mad physician were to administer poison and antidote, toxin and anti-toxin, in concurrent doses.

"Appraisal technique is clumsy in its efforts to differentiate between residential and other types of real property. Ordinarily, no account is taken of the important distinction which ought to be made between housing occupied solely by the owner with saving to himself, and rented housing which exists only as a commercial, profit-making commodity. This tends to throw owner-occupied property into the speculative field, and tempts the owner to surrender the 'social home values' for the lure of pecuniary profit.

"These are bad habits to which all our communities have been addicted. There seems to be little or no realization that they are productive of serious social and economic results. But they are there to see, underlying many of the conditions to which our welfare palliatives are applied—tinder for the flame of social disturbance unless corrected with calmness, intelligence, and wisdom."

FUTURISTIC BANK BUILDING

Indicating that bank building design is in for a revolutionary change, an ultra-streamlined structure is now being erected on Treasure Island for business during the 1939 Exposition.

The building will follow the moderne theme inside and out. There will be no windows, lighting coming from concealed artificial sources. Atmospheric temperatures will be controlled by the latest in air conditioning systems. A sound wave protective system, about which there is much secrecy, is also to be installed.

Bank fixtures will be of streamline design, and counters are to be built of glass tile, allowing unusual luminous effects. Nine tellers' windows will provide for ample service, and bank executives will be accommodated on an open platform to be readily accessible. A comfortably furnished lounge and writing room will be available to patrons.

The complete range of banking services will be provided for exhibitors and visitors by the Treasure Island Bank of America which will be staffed by thoroughly experienced men in every department. Owing to the large number of participants among the foreign nations and the many visitors expected from all parts of the world, foreign exchange will play an important part in the bank's business. Two shifts will be operated daily, including Sundays and holidays, so that the bank may remain open during Exposition hours.

The front of the building, which is in architectural harmony with the Exposition as a whole, will embody a huge illuminated map of California, on which an animated lighting system will indicate the location of each of the bank's 495 branches in 307 communities.

INCLUDE TREES IN YOUR PLANS

DAVEY, ORIGINATOR OF TREE SURGERY, OFFERS FREE
INSPECTION AND ESTIMATE.



SAN FRANCISCO Fresno LOS ANGELES
Rus Bldg. Mattei Bldg. Story Bldg.
SUiter 3377 Tucker 1929
Local phones in: Pasadena, Palo Alto,
Oakland, San Rafael, San Mateo

SKILL - KNOWLEDGE - RESPONSIBILITY

STRUCTURAL STEEL

For Class A Buildings,
Bridges, etc.

JUDSON PACIFIC CO.

609 MISSION STREET
SAN FRANCISCO

Plants: San Francisco - Oakland

USE BASALITE

Light-weight, pre-fabricated Con-
crete building products for floors,
walls, and roofs in your next
building.

BASALT ROCK COMPANY, INC.

Napa, California

NOISE Control

Office Quieting
Sound-proof Partitions
Acoustical Correction

WESTERN ASBESTOS CO.

Building Materials Mechanical Specialties
SACRAMENTO OAKLAND
SAN FRANCISCO

Is an
AGENCY ACCOUNT
expensive?



By saving valuable time and avoiding losses due to mistakes and delays, our Agency Service for handling securities often is an actual economy rather than an expense. But in any event the cost is moderate. Send for our descriptive booklet, *An Introduction to Agency Service*.

Just ask for Booklet M-2

**CROCKER FIRST
NATIONAL BANK**
OF SAN FRANCISCO
California's Oldest National Bank



*No longer a problem
for the Architect*

**TRANSIT
MIX CONCRETE**
AND MORTAR

makes delivery of material to the job swift and inexpensive . . . minimizing the architect's supervision costs and assuring his client a dependable mix.

Speed . . . Reliability . . . Economy
Let us co-operate with you

**Golden Gate-Atlas
Materials Co.**

16th and Harrison Streets
San Francisco
UNderhill 3650

SHASTA DAM ACTIVITY

Transformed within a month from an uninhabited and almost inaccessible mountainside covered with manzanita, scrub oak and chaparral, the east slope of the Sacramento River Canyon at the Shasta Dam site today is a bustling area of accelerating activity as construction proceeds on several phases of this major unit of the Central Valley Project.

Power shovels dig into the abutment excavation, dump trucks ramble over hastily-built roads, carpenters rush work on camp buildings, blacksmiths forge fresh points on drill steel, mechanics hammer away at new equipment, and occasionally a blast of dynamite reverberates up and down the broad canyon.

To the layman it looks and sounds tremendous. Engineers of the United States Bureau of Reclamation say the work still is largely in the preliminary stage, although now approaching heavy construction.

To celebrate this start on one of the world's mightiest concrete dams, Secretary of the Interior Harold L. Ickes officiated on October 22 at a Shasta Dam ceremony in Redding.

A simple order of a shovel engineer to a machinist, saying "O.K., turn it over," unceremoniously initiated work on the dam five weeks ago when ground was broken for the east abutment. Since that time dirt has been moved in large quantities and a gaping cavity dents the profile of the east slope about 200 feet above the river.

Power shovels with 2½-yard buckets, which are digging into the hillside at several elevations, soon will be augmented by three 4¾-yard electric shovels now being assembled. Each of these giant shovels is capable of excavating over six tons of material at a scoop. It is estimated more than 3,000,000 cubic yards of earth and rock will be removed from the slopes of the canyon to provide a suitable foundation for Shasta Dam.

Some of the material so far excavated has been used to grade construction roads which already gash the mountainside; some has been dumped into gullies to provide level spaces for

Found . . .

an ideal stop-over place for your drive to or from the State Association of California Architects Convention in San Francisco, October 13, 14, 15.

You will spend a comfortable night in a well appointed room to your liking. Private parking.

Convenient to 101 or drive the new San Simeon scenic highway.

MISSION INN
IN HISTORIC
MONTEREY

SISALKRAFT
REG. U. S. PAT. OFF.

**"More than a
building paper"**

THE SISALKRAFT CO.
205 West Wacker Drive
(Canal Station) Chicago, Ill.
55 New Montgomery Street
San Francisco, Calif.

**Pacific
Manufacturing
Company**

High Class Interior Finish
Quality Millwork

142 Sansome St. 6820 McKinley Ave.
San Francisco Los Angeles
GARfield 7755 THornwall 4196

1315 Seventh Street, Oakland
GLEncourt 7850



CLIENTS will bless you for installing the Wesix "49'er" ELECTRIC BATHROOM HEATER. But try it first in your own home. Certain that you will like its forty-nine inches of INSTANT RADIANT HEAT and QUICK CIRCULATING HEAT, we are offering this smart new heater at factory cost to architects, for personal use! Limit one heater per architect. List price \$21.50. Please write on your regular letterhead, to: 1018 WESIX BLDG., SAN FRANCISCO

WESIX
WESIX ELECTRIC HEATER CO.



**HERRICK
IRON WORKS**

STRUCTURAL STEEL
REINFORCING STEEL

18TH AND CAMPBELL STS.
OAKLAND, CALIF.
Phone GLencourt 1747

**FORDERER
CORNICE WORKS**

Manufacturers of

Hollow Metal Products
Interior Metal Trim
Elevator Fronts and Cabs
Metal Plaster Accessories
Sanitary Metal Base
Metal Cabinets
Flat and Roll Metal Screens
Commercial Refrigerators

269 POTRERO AVE.
San Francisco, Calif.
HEMlock 4100

the contractor's camp; and the rest has been deposited in stock piles of various grades for future use in embankment construction.

About 900 men are employed at the dam.

Construction also is under way on a large Government warehouse and storage yard to be located at Coram, three-quarters of a mile below the dam site. Power lines are being extended through the area, and high on the west bank, north of Coram, a sub-station is being erected to afford electricity for construction purposes.

The Government Camp, comprising 12 paved streets on which face five official buildings, 46 family residences, 27 duplex cottages, and two dormitories, is occupied by Bureau of Reclamation forces three miles east of the dam site. A new four-room schoolhouse, built by the contractor on Government property, was opened between the camp and the dam site. The Colonial Company's construction camp is completed and occupied on a knoll on the west side of the river above the dam site.

Construction is under way on a mess hall which will accommodate 312 diners at a sitting. Meals will be prepared at all hours of the day and night in a modern electric kitchen.

At a higher level is to be the contractor's administration building with various offices, drafting room, paymaster's windows and vault, and near it an office dormitory to accommodate 50 persons. On a hill overlooking the camp is the nearly completed hospital which will have first-aid and surgical rooms, four private bedrooms and a 20-bed ward.

Family residences will be spotted on terraces across a draw. Initial construction is to include 11 five-room houses, 50 three-room houses, and 70 two-room houses.

On a flat near the river are located the contractor's workshops and railroad yard which will include a combined warehouse and garage, machine shop, carpenters' shop, compressor plant, drill forge and fuel sheds.

Pitcher

**Improved
Disappearing Doors
Save 20% Space**

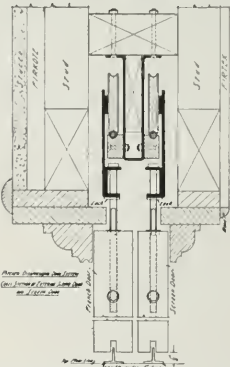

Joins with a 3 1/2" stud wall . . . steel studs . . . adjustable steel and wood track. Can be used for screen doors in connection with French doors. Send for detail drawing.

E. C. Pitcher Co.
461 Market Street
San Francisco

**Donovan Automatic
Awning Type
Windows**

Give 100% natural ventilation
and day-lighting control

**UNIVERSAL WINDOW
COMPANY**

Berkeley, California

**"AMERICAN MARSH"
Redi-Vac Vacuum
Heating Pump**

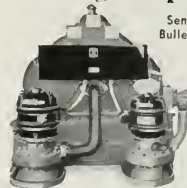

Send for
Bulletin 441

SIMONDS MACHINERY CO.
San Francisco Los Angeles
816 FOLSOM ST. 522 EAST 4TH ST.



SANTA MARIA INN

Santa Maria, California

*On the Coast Highway
between
Los Angeles and San Francisco*

OVER NIGHT

or

JUST A MEAL

FRANK J. MCCOY, *Owner*
Geo. A. Thompson, *Manager*

El Encanto Hotel

Santa Barbara

*On the Riviera, above the
Old Mission*

Frank J. McCoy, *Owner*
Fred F. Pimental, *Manager*

Independent Iron Works

Structural Steel
Ornamental Iron
Steel Service Stations
Steel Tanks
Standard Steel Mill Buildings
Bridges

821 Pine Street

Oakland

Clinton Construction Co. of California

*General
Contractors*

923 Folsom Street
San Francisco
SUtter 3440

WILL HANDLE ALUMINUM BLINDS

The MacDonald Hardware Manufacturing Company of 963 Harrison Street, San Francisco, announces that it has secured the exclusive sales rights in California for "Alumilite" Aluminum Slat Venetian blinds, manufactured exclusively by the Chicago Venetian Blind Company of Chicago, Ill.

According to Alvin M. Karstensen, general sales manager of the MacDonald Hardware Manufacturing Company, these blinds, having slats of 98 per cent pure aluminum and "Alumilited" to make them impervious to all atmospheric conditions, answer most of the negative questions that have ever been asked about Venetian blinds. He states that they are guaranteed not to pit, tarnish or oxidize and it is claimed that they will never have to be scrubbed or refinished.

Of particular interest, says Mr. Karstensen, is the fact that these blinds, in reflecting the sun's rays back out, overcome more than 90 per cent of the solar heat gain and keep rooms on sunny exposures as cool as those on shady exposures. Leading air conditioning engineers are employing this device as an auxiliary to air conditioning plants to overcome peak loads and cut plant operating expenses.

Continuing, Mr. Karstensen states that these blinds are fire-resistive, termite proof, immune to corrosion in salt air and much lighter in weight than ordinary blinds. The slats are curved and deflect considerably more light than ordinary flat slats, while refracting light to the underside of the slats which creates an effect of translucence that gives the blinds the appearance of spun glass.

Mr. Karstensen states that these blinds have been installed in many large and important monumental buildings, as well as schools, hospitals and industrial offices.

PROMOTED

Wilder A. Chapman has been appointed manager of laboratories for Robert W. Hunt Company, engineers, with headquarters at Chicago.

Mr. Chapman is a graduate of Tufts College with a B.S. in Chemistry.

COMFORT

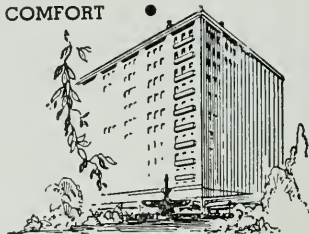

New HOTEL CLARK in Downtown LOS ANGELES

Convenience is another alluring of this hotel. Whether on business or pleasure bent, the Hotel Clark makes an ideal "base of operations," as well as a restful "billet" at the end of the day's "campaign." Good Food, naturally. And moderate charges, as well as for room accommodations, give final significance to assuring word — COMFORT

Single from \$2.50

Double from \$3.50

Fifth and Hill

ROOMS
555
BATHS

P. G. B. MORRISS, *Manager*

ANDERSON & RINGROSE

General Contractors

320 Market Street, San Francisco

Phone GARfield 2245

HIGH GRADE MILLWORK
AND INTERIOR FINISH
SASH AND DOORS

LANNOM BROS. MFG. CO.

FIFTH AND MAGNOLIA STREETS
OAKLAND, CALIFORNIA

Telephone: TEmplebar 3663

MULLEN MFG. COMPANY

BANK, STORE AND OFFICE
FIXTURES—CABINET WORK
OF GUARANTEED QUALITY
CHURCH SEATING

Office and Factory:
60-80 RAUSCH ST., Bet. 7th and 8th Sts.
San Francisco
Telephone UNderhill 5815

G. P. W. JENSEN & SON

Building Construction

320 Market Street, San Francisco
Phone: GARfield 2444

DINWIDDIE CONSTRUCTION COMPANY

BUILDERS

CROCKER BUILDING
SAN FRANCISCO

Carl T. Doell Co.

Plumbing
Heating

Plumbing Contractor
Veterans Memorial Building
Oakland

467 21ST STREET
OAKLAND

Telephone GLencourt 8246

STATEMENT OF THE OWNERSHIP, MAN- AGEMENT, CIRCULATION, ETC., RE- QUIRED BY THE ACT OF CONGRESS OF AUGUST 21, 1912 AND MARCH 3, 1933.

Of the Architect and Engineer, published
monthly at San Francisco, Calif., for October
1, 1938.

State of California
City and County of San Francisco } SS.

Before me, a notary public in and for the
state and county aforesaid, personally
appeared L. B. Penhorwood, who, having been
duly sworn according to law, deposes and says
that she is the Business Manager of The Archi-
tect and Engineer, and that the following is,
to the best of her knowledge and belief, a true
statement of the ownership, management (if
daily paper, the circulation), etc., of the afore-
said publication for the date shown in the
above caption, required by the Act of August
24, 1912, as amended by the Act of March 3,
1933, embodied in section 537, Postal Laws and
Regulations, printed on the reverse of this
form, to wit:

1. That the names and addresses of the pub-
lisher, editor, managing editor, and business
managers are:

Publisher, The Architect and Engineer, Inc.,
68 Post St., San Francisco, Calif.

Editor, F. W. Jones, 68 Post St., San Fran-
cisco, Calif.

Managing Editor—None.

Business Manager, L. B. Penhorwood, 68
Post St., San Francisco, Calif.

2. That the owner is: (If owned by a cor-
poration, its name and address must be stated
and also immediately thereunder the names
and addresses of stockholders owning or
holding one per cent or more of total amount
of stock. If not owned by a corporation, the
names and addresses of the individual owners
must be given. If owned by a firm, com-
pany, or other unincorporated concern, its
name and address, as well as those of each
individual member, must be given.)

The Architect and Engineer, Inc., 68 Post
St., San Francisco, Calif.

K. P. Kierulff, 68 Post St., San Francisco,
Calif.

E. N. Kierulff, 68 Post St., San Francisco,
Calif.

F. W. Jones, 68 Post St., San Francisco,
Calif.

L. B. Penhorwood, 68 Post St., San Fran-
cisco, Calif.

V. S. Yallup, 68 Post St., San Francisco,
Calif.

E. J. Cardinal, 942 Howard St., San Fran-
cisco, Calif.

3. That the known bondholders, mortgagees,
and other security holders owning or holding
one per cent or more of total amount of bonds,
mortgages, or other securities are: (If there
are none, so state.) E. J. Cardinal, 942
Howard St., San Francisco, Calif.

4. That the two paragraphs next above giv-
ing the names of the owners, stockholders, and
security holders, if any, contain not only the
list of stockholders and security holders as they
appear upon the books of the company but
also, in cases where the stockholder or security
holder appears upon the books of the company
as trustee or in any other fiduciary relation,
the name of the person or corporation, for
whom such trustee is acting, is given; also
that the said two paragraphs contain state-
ments embracing affiant's full knowledge and
belief as to the circumstances and conditions
under which stockholders and security holders
who do not appear upon the books of the com-
pany as trustees, hold stock and securities in a
capacity other than of a bona fide owner; and
that this affiant has no reason to believe that any
other person, association, or corporation has
any interest direct or indirect in the said stock
bonds, or other securities than as so stated by
him.

5. That the average number of copies of each
issue of this publication sold or distributed,
through the mails or otherwise, to paid sub-
scribers during the twelve months prece-
ding the date shown above is, (This information is
required from daily publications only.)

L. B. Penhorwood, Business Mgr.

Sworn to and subscribed before me the 28th
day of September, 1938.

(Seal) MARY D. F. HUDSON

(My commission expires Dec. 22, 1940.)

Louis C. Dunn, Inc.

GENERAL
CONTRACTORS

Monadnock Building
San Francisco

Phone: DOuglas 4632

Empire Construction Co., Ltd.

Builders



RUSS BUILDING
SAN FRANCISCO
SUtter 2989

Smith

Lumber Company

WHOLESALE - JOBBING - RETAIL

FACTORY AND BUILDING LUMBER
PLYWOODS - ROOFING

DISTRIBUTING YARDS

San Francisco

Oakland

4th & Channel

19th Ave. &

Market 0103

Estuary

Market 0103

FRuitvale 3174

YOUR INQUIRIES SOLICITED

JOSEPH MUSTO SONS-KEENAN COMPANY

MARBLE
and
ONYX

535 NORTH POINT STREET
SAN FRANCISCO
1801 S. SOTO STREET
LOS ANGELES

ABBOT A. HANKS, INC.
Engineers & Chemists

INSPECTING — TESTING — CONSULTING
 CONCRETE • STEEL • MATERIALS
 CHEMICAL AND TESTING
 LABORATORIES

- RESEARCH AND INVESTIGATION •
- TESTS OF STRUCTURAL MATERIALS
- DESIGN OF CONCRETE MIXES
- SHOP AND ERECTION INSPECTION OF STRUCTURES AND EQUIPMENT
- INVESTIGATION OF STRUCTURES AND MATERIALS
- TESTS AND INVESTIGATION OF FOUNDATION SOILS
- FIRE RESISTANCE AND INSULATION TESTS

624 Sacramento Street, San Francisco

Phone GARfield 1164

Hunter & Hudson

Consulting Engineers
 DESIGNERS OF HEATING
 AIR CONDITIONING
 VENTILATING AND WIRING
 SYSTEMS, MECHANICAL
 AND ELECTRICAL EQUIP-
 MENT OF BUILDINGS

41 SUTTER STREET
 ROOM 710
 San Francisco California

Whether large or small
 Stucco Buildings
 are Best Protected
 with

**CEMENTEX
 DUNNE'S**

Coating for Stucco
 The Hayward High School
 is an outstanding example

FRANK W. DUNNE CO.
 41st and Linden Sts. Oakland, Calif.
 MAKERS OF GOOD PAINT

VAUGHN - G. E. WITT Co.

Manufacturers and Distributors

- | | |
|---------------------------------|------------------------------|
| Pump Governors | Oil Heaters |
| Safety Pump Governors | Relief Valves |
| Automatic Gas Regulating Valves | Oil Burner Governors |
| Gas Burning Equipment | Oil Burners |
| Vacuum Pump Governors | Oil Pumping Sets |
| Vacuum Regulating Valves | Oil Valves |
| Continuous Flow Steam Traps | Oil and Steam Strainers |
| Thermostats | Duplex Oil Pumps |
| Reducing Valves | Rotary Oil Pumps |
| | Boiler Feed Pumps |
| | Water Heaters |
| | Boiler Feed-Water Regulators |

4224-28 Hollis St., Emeryville, Oakland

**THE
 HERMANN SAFE CO.**

MANUFACTURERS AND DEALERS
 OF

FIRE AND BURGLAR PROOF
 SAFES AND VAULTS, SAFE-
 DEPOSIT BOXES, ETC.

200 HOWARD STREET
 SAN FRANCISCO
 GARfield 3041 - 3042

**REPUBLIC STEEL
 CORPORATION**



Manufacturers of

ENDURO Stainless Steel; TON-
 CAN Copper Molybdenum Iron
 Sheets and Pipe; and Steel Pipe,
 Sheets and Reinforcing Bar for
 every building purpose.

Write for information

Rialto Building, San Francisco, Calif.
 Edison Building, Los Angeles, Calif.
 White-Henry-Stuart Bldg., Seattle, Wash.

MILLWORK

FOR
 SCHOOLS
 AND
 FINE RESIDENCES

GRAVES COMPANY

2000 Pasadena Ave.
 Los Angeles

Robert W. Hunt Company
 ENGINEERS

Inspection • Tests • Consultation
 Schools and Other Structures
 Are Built as Designed

*When Construction Materials are
 Inspected at point of Manufacture
 and during Erection by*

ROBERT W. HUNT COMPANY

*Cement, Concrete, Chemical, Metallurgical,
 X-Ray and Physical Laboratories*

Chicago - New York - Pittsburgh
 Los Angeles - All Large Cities
 San Francisco, 251 Kearny Street

**JOHN
 CASSARETTO**

—Since 1886—And Still Active—

Building Materials

READY MIX CONCRETE
 ROCK - SAND - GRAVEL - LIME
 CEMENT - PLASTER - MORTAR
 METAL LATH - WOOD LATH
 STUCCO - WIRE NETTING

Service Unexcelled

Bunkers
 Sixth and Channel, San Francisco
 Phones: GARfield 3176, GARfield 3177

HIGH FIRED
Kraftile
 THE TERRA COTTA WITH THE 10 ADVANTAGES

Master Kraftile...Terra Cotta Wall
 Units...Ceramic Facings...Cutting
 Machines...Swimming Pool Ladder
 Steps...Swimming Pool Overflow
 Hand Rails...Bathroom Accessories
 ...Enamelled Brick...Special Shapes

*See Sweets Architectural Catalog, No. 11-5,
 Section 11, Fifth Catalog*

KRAFTILE COMPANY
 NILES - CALIFORNIA
 (San Francisco Bay Area)

**FINE WATER COLORS
 AND PAPERS
 FOR ARCHITECTURAL
 RENDERINGS**

**H. S. CROCKER
 COMPANY, Inc.**

720 MISSION STREET
 MARKET STREET AT SECOND
 SAN FRANCISCO

**THE TORMEY
 COMPANY**

GENERAL PAINTERS
 AND DECORATORS

Phone UNDerhill 1913

563 FULTON STREET
 San Francisco

THE
ARCHITECT
AND
ENGINEER

DECEMBER 1938



In the
LONGEST BRIDGE

The
**HIGHEST
STACK**

Crossing the long arm of lower San Francisco Bay is the San Mateo-Hayward Bridge — longest in the world — 16 miles — Towering above the surrounding landscape like a giant finger at Selw, California, is the new refinery stack of American Smelting & Refining Co. — highest in the world 618 feet — Diving deep into the very bowels of the earth at Wasco, California, is the No. 1 C.L.A. well of the Continental Oil Company — deepest in the world 15,001 feet.

For all three of these unmatched engineering achievements of man, Golden Gate Cements were specified and used exclusively — Thus as the world looks to the Pacific Coast for outstanding projects, the Coast looks to Golden Gate Cement for outstanding performance and unequalled assurance of permanence.

Whether you are planning a structure of record-breaking magnitude or merely a foundation for a house, it will pay you to specify and use 'Golden Gate Cement' for Sound Construction."

Ask Your Building Material Dealer

**GOLDEN
GATE
CEMENTS**
were used
EXCLUSIVELY

The
**DEEPEST
OIL WELL**

Produced by

San Francisco
Los Angeles

PACIFIC PORTLAND CEMENT COMPANY

Portland
Seattle

COASTWIDE SERVICE

RUNNING FIRE

by
MARK DANIELS, A.I.A.

When Is A Show Not A Show

My answer to this title is, when it is an auto show.

At the request of my sister, who is about to purchase an automobile, I went to see the auto show. The aged lady is interested in one particular make of car and it was her urgent call for advice that prompted me to see what that car was like. On arriving at the auditorium, I found a mob of people clattering aisles, passages, sitting on tops of hoods, on the tops of cars and otherwise smothering everything from the floor up to a height of about ten feet. Rudy Vallee was crooning.

No amount of creeping and peeping between persons enabled me to determine just where the particular brand of car I was looking for was located, nor to see it, had I been able to locate it. After an hour of sweating struggle I gave up in disgust.

As far as autos were concerned, it was not an auto show. As far as a demonstration of Rudy Vallee's crooning, I could get a better one over the radio. I so reported to my sister and she also gave up in disgust. Perhaps a good light should be hid under a bushel, but here was one instance where the principle needed a change.

Faith

Incredulity is capable of cancerous growth. With us Americans it starts developing at an early age and is, no doubt, a result of the old practice of the Yankees in the gentle art of cheating those with whom they do business. Such practices as weighing the hand with the meat, putting sand in the sugar, selling wooden nutmeats, developed as a natural corollary. The expressions, "I'm from Missouri," "Don't take any wooden money," "rained horse," "gyp" and a host of other delineations quickly caught on with the youth of the country until no "wise guy" believed in anything but his own infallibility.

Such an attitude of mind is, I believe, a factor in the waning influence of religion in this country. At least one essential to the practice of any form of the Christian religion is faith. If we drift into a state of utter disbelief in every-

thing, religion is in for a sorry time. Frequently, where analyzed, these doubts and disbeliefs show up more as absurdities and incongruities than anything else, as G. K. Chesterton once pointed out to me.

We were discussing the subject of beliefs and unbeliefs, Chesterton said that what puzzled him most was that he found many who believed there was once a man named Noah and as many who believed there was an ark but that he seldom found one who believed there was once a Noah's Ark. Well, perhaps the time will come when we will say there are many architects and there is much poor architecture, but there are no poor architects.

Ingenuous

Some few days ago it became necessary to look up the characters and symbols of the Chinese Eight Immortals. Strange to say, all but Chung-Li Ch'uan, who lived in the 12th century, B. C., are comparatively modern, as late as the sixth century. Still more strange, two of them are women.

Each of these immortals carries his own particular symbol. One has a wooden flute; another, castanets, and another a sword, and so on. And it would be a grievous error on the part of any architect, in using Chinese symbolism in his decorative motifs to have the man whose symbol is a flute, carrying, perhaps, a bucket of paint. So it became necessary to trace these emblems and symbols correctly.

In a book on Chinese symbolism I found the eight immortals correctly represented and described. It appears that Chung-Li Ch'uan was the first of all and that he, at the tender age of fifty, decided to become a philosopher. As everyone knows, no one can become a philosopher until he goes to a mountain and sits on a rock for fifty to a hundred years, contemplating either his navel or the infinite or both until the wit of philosophy descends upon him. On his way to the mountain Chung-Li, whose emblem is a fan, saw a lovely maiden sitting on a grate jutting the earth. He asked her why she did this and she replied, "When my very late and much lamented husband died, he placed upon me the

injunction and exacted from me the promise that I would not marry again until the earth upon his grave was dry." And she proceeded with her jannng of the grate. But that is a custom that has disappeared in this country, it takes too long.

Gone Scrooge

I don't see why we grown-ups hang around these Xmas windows. The other day I paused to glance at a puppet show in a down town window. I was only mildly curious. These childish entertainments are beneath us grown-ups. Besides, there was such a mob of excited children there that a man with an investigatinz turn of mind could hardly elbow his way up to the window.

Ahead of me was a grumpy old man showing his way through the mass of dancing youngsters. He half turned to me and said, "Why can't they keep their youngsters off the streets? Here's a man going to see what's in the shop windows with all these kids around?" and he pushed one aside.

"Of course," I said to him. "They might show those puppet and trains and skin and things in spring or autumn midterm when the children are in school. Then people like you and me would have a chance."

"Herrumph," was all he said as he shoved a couple more children aside.

I stayed close behind him, not that I was interested in the puppet show (although it was really funny), but only to study the actions of this old crab. Why some grown-ups will spend valuable time, watchinz Parah hit Judy over the head with a stick (although it makes you laugh) I don't know. Anyhow the old fellow was hard boiled. He shouldered and squirmed so that I had a hard time keepinz close to him.

At last he got right up to the plate glass where he continued to mumble and grumble and bob about like the children around him. He was awful a regular scrooge. Finally, even I lost patience and had to shove him aside with my elbow in his ribs so I could see the show myself. Why do grown-ups hang around these Christmas windows anyway?

LIGHTWEIGHT INTERLOCKING SHINGLE TILE

THIS NEW TYPE TILE IS ADAPTABLE TO ALMOST ANY
STYLE OF ARCHITECTURE, REQUIRES HALF THE
NUMBER OF TILES PER SQUARE AS ORDINARY SHINGLE
TILE AND NEEDS NO EXTRA UNDER-CONSTRUCTION
TO CARRY EXCESSIVE WEIGHT.

WRITE FOR DESCRIPTIVE FOLDER.

Another new development by

GLADDING, McBEAN & CO.

2901 LOS FELIZ BOULEVARD LOS ANGELES, CALIFORNIA
SAN FRANCISCO • PORTLAND • SEATTLE • OAKLAND • SPOKANE • VANCOUVER, B. C.

ARCHITECT & ENGINEER

Fred W. Jones, Editor

Mark Daniels, A. I. A., Associate Editor

Edgar N. Kierulff, Assistant Editor

CONSULTING BOARD OF EDITORS

Architectural—

Arthur Brown, Jr.
Frederick H. Meyer
Timothy L. Pfueger
Will G. Corlett
Harry Michelsen
John J. Donovan
Lewis P. Hobart
David C. Allison
Gordon B. Kaufmann
Harris C. Allen
Glenn Stanton
Paul R. Hunter
C. H. Alden

Engineering—

H. J. Brunnier
L. H. Nishkian
William Adrian
Wm. H. Popert
Homer N. Hadley
John J. Gould
Geo. E. Atkins

Advertising Manager—

J. Leslie Meek

Architects' Reports—

Vernon S. Yallop

THE ARCHITECT AND ENGINEER, INC., 69 Post Street, San Francisco, EXbrook 7182. President, K. P. Kierulff; vice-president, Frederick W. Jones; secretary, L. B. Penhwood. Los Angeles office, 832 W. Fifth Street. Published on the 12th on each month. Entered as second class matter, November 2, 1905 at the Postoffice at San Francisco, California, under the Act of March 3, 1879. Subscriptions, United States and Pan America, \$3.00 a year; Foreign countries, \$5.00 a year; single copy \$.50.

Contents for December

Running Fire Mark Daniels, A. T. A.	1
Anent the Recent Exhibition Michael Goodman	4
Recent Work of Spencer, Blanchard & Maher, Architects William Hamilton	15
Two Houses by Henry H. Gutterson	27
Co-ordination of the Building Industries Charles M. Cadman	33
An Analysis of Three Types of House Insulation J. R. Von Sternberg, R. A.	37
Yuletide Outdoor Lighting A. M. Barrell	39
Ante-Bellum Homes P. J. Rinderle	43
World's Fair Builders—Jess Stanton	47
School Built of Plywood	51
State Association Bulletin Harris C. Allen	55

PLATES AND ILLUSTRATIONS

Dining Room Detail, Ahwahnee Hotel, Yosemite National Park	14
Badger Pass Ski Lodge, Yosemite Spencer, Blanchard & Maher, Architects	15-17
Mariposa Lodge, Yosemite National Park Spencer, Blanchard & Maher, Architects	18-19
National Park Service Stations Spencer, Blanchard & Maher, Architects	20-22
Cottage for Otis R. Marston, Berkeley Spencer, Blanchard & Maher, Architects	23-24
House Creek Stables, Sonoma County, California	25-26
House for Mr. and Mrs. H. L. Adams, Near Chico Henry H. Gutterson, Architect	27-28
Residence of Mr. and Mrs. H. A. Irving, Atherton	30-31
Outdoor Christmas Lighting	39-41
Harwell Hamilton Harris House, Los Angeles	42



PHOTO OF PART OF THE EXHIBITION

ANENT THE RECENT EXHIBITION

MICHAEL GOODMAN in *S. F. Art Association Bulletin*

MY PARTICIPATION as an invited exhibitor, as well as the fact that I am writing in retrospect, challenges my judicious weighing of an exhibit already gone. When these comments are printed herein, the show of veritable "portraits" by members of the American Institute of Architects, Northern California District, will be off the walls and returned to gather dust in the various offices of their conception.

According to the opinion of a national magazine which is beginning to sell architecture to the public, American building in general is intraverted. In this case, for once, some architects proposed to have a co-operative show with a touch of collective anonymity; to put up a general topical display of the achievements by the profession in the various fields of design. This resolved itself, however, as if by force of gravity, into the usual individual display, with one exception, that no awards were given.

While those who have seen the exhibit carried away a lasting impression of good photography, a future commentator will ponder over the question of whether the houses of the "California School," in florescence now, came before good photography, or, if the concurrent school of photography brought about photogenic houses.

The beneficent surroundings in California and the opportunities offered to architects, produce a new idiom of beautiful designs in the field of the house for the open country. Such houses predominated the show. Solutions were displayed for individual clients by individual architects, perhaps the best. Unfortunately, their number did not include many others, some of whom may possess the final answer to the secret of the "House," and who practice somewhere unsung and untold.

Group housing was absent, as well as the now faintly pulsating prefabricated houses. Designs for hillside city lots were distinctive, as one would expect on the Pacific slope. The limitations imposed on the architects

who design for San Francisco lots are probably responsible for the small number of city residences shown. I wonder if the necessity to stress panoramic cities, in view of equally panoramic rents, may tend to sacrifice some arrangement of the interiors. The newly completed school buildings were very stimulating and remind us of the activity in the valley towns, where (Attention! fellow members of the Art Association) some allocations of money trickled their way into mural decorations projects. As a comment on present conditions, lacking in number were commissions of industrial and commercial types of building. Despite the belief that the house of the future will be a mechanical solution, there was no indication of any emphasis, except in a few instances, on the utilities of the house—I mean bathrooms, kitchens, closet arrangements and such. Perhaps this would have been brought out better under the topical system of exhibiting. I am sure that all my colleagues will join me in expressing an appreciation to Ernest Born, who designed the show and some exhibitors who helped him to put it over.

FEDERAL HOUSING BULLETIN

"Planning Profitable Neighborhoods" is the title of a new bulletin just issued by the Federal Housing Administration as a guide to good neighborhood development. The principles outlined are not new or unique; they have been subjected to successful practical application for many years.

Land Planning ideas of an experimental nature and those which are unproved or which require special topography or extensive acreage have been consciously omitted. Emphasis is placed upon the fact that good planning pays dividends, both from the standpoint of economical development and of a readily marketable product.

Bulletin No. 7, "Planning Profitable Neighborhoods," is available through the Superintendent of Documents, Government Printing Office, Washington, D.C., for 20 cents a copy. All orders for this publication should be addressed to him. Postage stamps not accepted.

"CONTROL BY JOHNSON"

THROUGHOUT THE CAMPUSES OF MANY INSTITUTIONS

And the University of Kentucky, Lexington, is a good example! Johnson automatic temperature control, with individual thermostats in each principal room, is employed in the Teachers' Training Building, the Library, Mc Vey Hall, and the Dairy Products Building. The other buildings, pictured here, and several others as well, are equipped with Johnson-controlled ventilating systems.

When the new central station heating plant was built, recently, Johnson *Duo-Stats* were installed as "master controllers" for almost every building on the campus. Twenty-seven of these unique instruments, operating to maintain the proper relationship between outdoor and heating system temperatures, insure steam economy and heating plant efficiency . . . The College of Engineering is responsible for the engineering work at Kentucky.

Special devices are at work in the Tobacco Research Laboratory . . . Regardless of the problems encountered in automatic temperature and humidity control . . . heating, cooling, ventilating, air conditioning, special processing . . . Johnson engineers are prepared to supply the correct answer.

JOHNSON SERVICE COMPANY
Milwaukee, Wisconsin and direct branch offices in principal cities



Law Bldg., University of Kentucky,



Teachers' Training Bldg.



Library Building



West Unit, Engineering Bldg.



Student Union Bldg.



Mc Vey Hall



VIEW IN SUBBASEMENT OF LIBRARY OF CONGRESS ANNEX, WASHINGTON, D. C., SHOWING ELEVATOR TERMINALS AND END OF CORRIDOR THAT JOINS THE ANNEX TO THE MAIN LIBRARY OF CONGRESS. GLAZED TERRA COTTA WALL UNITS ARE OF KRAFTILE. THE PRODUCT OF THE COMPANY AT NILES, CALIFORNIA, WAS SELECTED AFTER NATION-WIDE BIDDING.

CALIFORNIA FIRM COMPLETES IMPORTANT EASTERN CONTRACT

WORD of completion of the glazed terra cotta wall units' installation in the subbasement of the Library of Congress Annex, Washington, D.C., has been received by C. W. Kraft of Kraftile Company, Niles, California, awarded the contract in a nationwide competition.

After five years of construction, the annex is now nearing completion. Principal joining link between the annex building and the present edifice of the Library of Congress is the subsurface corridor, the arterial nature of which required careful selection of wall finish material.

Glazed terra cotta wall units was the material selected to meet the requirements which involved permanence of color, surface with cleanly appearance, surface finish of attractive character, ability to resist marring and scratching, and capacity to meet lighting conditions, as well as fire-resisting qualities.

Standard size units of Kraftile were adopted for the walls of the corridor and elevator lobbies. The unit has a face size of 8x16 inches and thickness of $3\frac{7}{8}$ inches for wall partitions and of $1\frac{7}{8}$ for furring.

The color used is a mottle of cream and buff, with semi-matt finish.

Construction of the annex is being done by the Consolidated Engineering Corporation of Baltimore, Maryland. David Lynn is architect; consultants: Pierson & Wilson, Alex B. Trowbridge.



SUBBASEMENT OF LIBRARY OF CONGRESS ANNEX, WASHINGTON, D. C., SHOWING INSTALLATION OF 8 x 16 GLAZED TERRA COTTA WALL UNITS, STANDARD SIZE OF KRAFTILE COMPANY OF NILES, CALIFORNIA. JUTTING FROM WALL AT RIGHT IS SPECIAL "DUMB-WAITER" FOR TRANSPORTING BOOKS.

... and the floors are *Hard Maple*



• Modernity distinguishes the Hollywood Turf Club, at Inglewood, California—a true modernity that combines beauty with functional utility, in every detail. The floors in the Lounge and Dining Room (right), Public Club and Bar are Hard Maple—"selected for appearance, durability, and in some cases for dancing purposes," says Stiles O. Clements, Architect, Los Angeles.



ADVENTURE awaits the architect who goes modern with Maple! He'll find numerous combinations* of patterns and wood-colors and color finishes that are versatile, practical and *safe!*

Maple never forces design, merely *complements* it—with a clean and crisp character . . . bright, cheery, sanitary, and *warm*. It permits great liberty with other elements, without risk of coldness or monotony—wears well on the eye, as under the feet.

And of course, in *use*, nothing is more modern than Hard Maple. Resilient, smooth

and non-slippery, it slows up fatigue, protects health, lowers maintenance and cleaning costs, simplifies alterations, and outwears any other comfortable floor!

When you want a *modern* flooring, consider Hard Maple—for Maple is as modern today as ever . . . And in **MFMA** Maple, you assure the same qualities which have distinguished Hard Maple through the years, in buildings of every kind.

MAPLE FLOORING MANUFACTURERS ASSOCIATION
1790 McCormick Building, Chicago, Illinois

See our catalog data in Sweet's, Sec. 11-76. Our service and research department will gladly assist you with your flooring problems. Write us.

***MANY WAYS YOU CAN USE HARD MAPLE:**
Maple comes: 1. In unselected color (natural finish) under standard grading. 2. Graded for color tone (as "White Clear" or "Brown Clear") for especially "even-color" floors, or color-pattern effects. 3. Color finished—in Early American, Spanish Brown, Ebony Black, and other colors of rich beauty, which match any decorative scheme.

Floor with **MFMA Maple**
(NORTHERN HARD)

GIFTS THAT GROW

By **BERNIECE ASHDOWN**
Landscape Architect

NO Christmas list is quite complete without a potted plant or two. They always make lovely gifts and their life and color are especially appreciated during the Christmas season. Nor is their charm short lived; with proper care they will become increasingly lovely from year to year.

Choose unusual and easily grown varieties and inquire about the care of the plant when you purchase it. This information can later be passed on to the recipient.

The **Poinsettia** is the most decorative of all Christmas plants. Although it blooms at Christmas time, it may, with proper care, be kept in bloom for fully ten weeks. It is a native of Mexico and requires a higher and more even temperature than most plants. Any sudden change will cause its leaves to fall. During blooming season it needs a great deal of water. After it has finished blooming, the sprinkling should be gradually decreased, keeping the plant almost dry during the summer. In August it should be cut back, leaving two or three buds to each stock. Frequent watering is then resumed.

Jerusalem Cherry is very attractive and is of easy culture. Like most other plants, it dislikes drafts and requires a moderate quantity of water. It bears its showy berries almost continually except for short rest periods. During this time it should be clipped back two or three inches and given less water than usual. New plants grow quickly from seed.

Primroses are both dainty and hardy. Few plants are of easier culture. They come in every hue from crimson to white, and many are delightfully fragrant. They require quite a lot of water but should never be sprinkled, because the hairy surfaces of their leaves hold the moisture and cause decay.

Pepper plants give a festive spirit, but are short lived.

Ferns are always acceptable and are adaptable to a wide range of growing conditions.

There are many very attractive evergreen foliage plants which require less light than those that bloom and therefore may be used to advantage in hallways and dark corners.

Old fashioned **Rose Geranium** has deliciously fragrant leaves which make it always a welcome gift.

The **Cyclamen** is often compared to the Orchid. In some ways it is even lovelier. Good, healthy plants should bloom for many years. The Cyclamen requires a great deal of water, but will decay if it is not properly drained, or if water stands around the crown of the plant. It abhors strong sunlight, so should be placed in a protected spot. During the rest period, which usually begins in May, it should be given only enough water to keep the bulb from shriveling. In September it may be re-potted and kept well watered for another blooming season.

Culture of potted plants is quite simple if a few general rules are observed.

Although the various plant requirements differ greatly, most plants need an abundance of daylight and many require a great deal of direct sunlight.

The majority thrive best in a room temperature of about 65 degrees, but will allow a great deal of latitude so long as extremes are avoided and there are no drafts.

How often a plant needs water depends upon the soil texture, the size and type of pot and room temperature and humidity, as well as upon the type of plant. The safest rule to follow in watering plants is to give them water whenever the top crust of the soil seems dry. Then give it a thorough soak-

ing by either setting it in a pail of water deep enough to cover the pot until it stops bubbling, or set the pot in a pan of water until the top surface of the soil is wet. Often when water is poured by the cupful around a plant, it runs around the outside of the pot and out of the hole in the bottom without penetrating the center root mass, leaving the plant still much in need of nourishment.

The importance of drainage cannot be overemphasized. Never should a plant be allowed to set in drainage saucers filled with water. It will cause the roots in the bottom of the pot to decay and the result will be an unhealthy plant. To avoid danger of this, a layer of pebbles should be put in the saucer and the pot set on the pebbles.

If these rules are followed, health and prosperity will accompany your Christmas plants throughout the new year.

CREDIT FOR MISS BASHFORD

Dear Editor:

The American Society of Landscape Architects is endeavoring to urge upon the editors of all magazines publishing photographs of landscape architectural work the desirability of giving credit to those practitioners whose work is illustrated in any of the photographs printed.

In your October number I find, on pages 22 and 23, photographs showing the residence of Mr. and Mrs. Arthur Smiley at Bel Air, Calif., which illustrate work done by the office of Miss Katherine Bashford, landscape architect, of Los Angeles.

I realize that material submitted for publication does not always carry with it adequate credit lines, and that in some cases further information is practically impossible to obtain. I therefore send this to you merely as a reminder of our desire to see a printed acknowledgment whenever credit rightly belongs to a landscape architect, and in the hope that you may wish to insert a note of correction in a subsequent issue, as is the custom in most of the leading architectural magazines.

Very truly yours,

BRADFORD WILLIAMS,
Corresponding Secretary.

MORE APPLAUSE

Dear Mr. Editor:

The September issue of The Architect and Engineer is one of the finest presentations of plywood that we have seen. The thoroughness of the treatment and the many pictures should serve to acquaint every architect with the many advantages of plywood construction. We wish to sincerely compliment you on this issue.

Yours very truly,
KRAFTWOOD Division of M. & M.
Woodworking Co.

THE ARCHITECT AND ENGINEER

*A few hours
a few dollars*
AND
Sealcon

WILL MAKE YOUR
BASEMENT

DRY

SEALCON forms a water-resisting seal for basement walls and floors, brick, stucco or any other masonry. Just paint it on, inside or outside, to any wet or dry surface. One coat gives lasting protection . . .

conquers dampness and seeping water. A perfect base, or mixture, for oil paint.

**EASIER
TO APPLY
THAN PAINT**

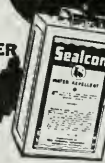

**ASK DEALER
LISTED
BELOW
ABOUT**

Sealcon
GUNN, CARLE & CO.

Distributors

20 Potrero Ave. UNderhill 5482
SAN FRANCISCO

Specify "PENNVERNON"...not just "window glass"



Photograph by Johnston & Johnston



NOT TOO HOT, NOT TOO COOL... but just right must be the temperature of the Pennvernon melting tanks if the superior quality of Pennvernon Glass is to be maintained. This Pennvernon Craftsman assures proper melting conditions by constant vigilance with his pyrometer.

Our new booklet, called "The Making of a Leader", describes in dramatic pictures the manufacture of Pennvernon Window Glass. To get your free copy of this interesting book, sign and mail this coupon to

PITTSBURGH
PLATE GLASS COMPANY
2116 Grant Building, Pittsburgh, Pa.

Name _____
Address _____
City _____ State _____

W. P. FULLER & CO., PACIFIC COAST DISTRIBUTORS

DINING ROOM DETAIL FOR ANNUAL BRACEBRIDGE CHRISTMAS CEREMONY AT AHWAHNEE HOTEL, YOSEMITE NATIONAL PARK
DESIGNED BY JEANETTE DYER SPENCER





SOUTH FACADE, BADGER PASS SKI LODGE, YOSEMITE NATIONAL PARK, CALIFORNIA

Spencer, Blanchard & Maher, Architects

RECENT WORK OF SPENCER, BLANCHARD & MAHER

By WILLIAM HAMILTON

THE work of the architectural firm of Spencer, Blanchard & Maher of San Francisco shows great variety; emphasis on brick in the Marston cottage, emphasis on plaster in the shop for Winifred Gray Wise, emphasis on wood in the Walbridge ranch and the Badger Pass ski lodge. Whatever the material, the work shows an interest in texture which is quite Californian and stems from that grand old master of them all—Bernard Maybeck.

Texture has come to be an accepted relief to the functional interior. Here we have texture clothing the exterior. Therefore, the architecture should probably be called organic, as true functionalists would feel this delight in materials a distracting element.

A cursory glance at the Marston cottage shows an English brick and timber, romantic structure, traditional in the elaboration of the

chimney pots, symbolizing the warmth of the hearth within. But look at the plan. The large fireplace, with its brick molded frame ground on the job, is not the main source of heat. Installed in the basement is a plenary heating system which heats the entire cottage from below,

BADGER PASS SKI LODGE—CARVED WOODEN PLAQUE BY ROBERT B. HOWARD





BADGER PASS SKI LODGE—DETAIL OF FIREPLACE

The cast iron ski figures that form the face of the chimney are by Robert Boardman Howard. They not only depict the skier's skill but are excellent examples of the sculptor's art.



BADGER PASS SKI LODGE WITH SNOW
AT ITS MAXIMUM DEPTH

thus developing a uniformity of temperature which has nothing to do with old English tradition. The leaded glass window facing the garden is traditional, so are the open trusses above. The acoustics of the room, designed for music and the dance, are excellent. The slight variances in angle of the tiny window panes prevents the brittle reflection of sound we so often hear in interiors with an equally large glass area.

Five of the buildings illustrated are in California State and National parks; the Point Lobos gate lodge, the Mariposa lodge, the Camp Curry dining room, the Chinquapin service station, and the Badger ski lodge. The first, the Point Lobos gate lodge, is the only building similar to the Marston cottage in its smallness of scale and romantic setting. There the similarity ends, however, for the gate lodge is quieter in design, its simplicity expressing man's humble wonder at the stern beauty of the sea and the rich rugged landscape of the shore. The Marston cottage expresses the rich personal life of its occupants; here the mood is more restful. The lodge is built of wood, in the style of our pioneer ancestors, and painted an off white, a color which has now become popular in the vicinity as it harmonizes with sea and sand and cliffs and seems as eternal as they.

The Chinquapin service station and lunch room is also wooden architecture, in the style of our California pioneers. Placed at the rather bleak intersection of two high mountain roads,

it also is white but rather larger in scale than the gate lodge. The station is operated by a man and his wife who have living quarters for themselves to the left of the lunch room.

The Mariposa lodge is also pioneer in style, though very different in aspect. It is situated in the heart of the Mariposa Grove of Big Trees, surrounded by forest giants that make it seem a quarter of its true size. Were this building among oaks it would seem a barn; here it is a cottage. The color is a red that comes as close as possible to the red of the sequoia trunks. Eaves are an apple green. Furnishings are as simple and straightforward as the architecture. The detail of a table, set for luncheon, shows tablecloths made of overall material, and bandanna handkerchiefs used for napkins. The chief function of this lodge is to feed the hungry tourists who visit the big trees at noon. Sometimes as many as 450 are served. It also contains twelve bedrooms for overnight guests. One of these was occupied last July by President Franklin Delano Roosevelt on his visit to the Yosemite.

The Badger Pass ski lodge is about an hour's drive from the Mariposa lodge, in high country, but a country of firs and pines of normal size. Here the problem was totally different, as is likewise the architecture which developed from it. Not having the scale of the sequoias to contend with, there was no need for intimate detail to humanize a Gargantuan world, so here, starting with the heavy bulk of the ski boot, the ar-



CAMP CURRY DINING ROOM—DETAIL
OF FIREPLACE



MARIPOSA LODGE, YOSEMITE NATIONAL PARK, WHERE PRESIDENT ROOSEVELT STOPPED DURING HIS RECENT TRIP TO CALIFORNIA

chitecture is large in scale, consciously heavy, always masculine. The roof is of unbarked mountain pine slabs and peeled slabs are used for siding; huge brackets support the wide overhang of the roof. The feature of the exterior is the wide deck where skiers lunch, decide on the next run or watch the finish of the downhill or the slalome. This deck is ten feet above the ground in autumn and later in the season slightly below snow level. It houses lockers and ski waxing space. The pooka, or small tower at the side, is the entrance way to this space. It has two doors, one below and one above, with a downstair used when the snow is high.

The ski equipment and ski rental units are housed in the interior at one end of the building; the cafeteria at the other end, with a door

onto the deck and into the lounge. The lounge centers around a great double stacked steel and cast iron fireplace which is at once a decorative feature and an efficient heating unit. Low down at both sides of the outer stack a cold air vent draws in the cold air of the room. This comes out again at the top, heated not only by hot air from the fireplace but from the kitchen stoves and boiler room furnace as well. In addition, the cast iron face of the chimney gradually becomes warm and radiates heat. The cast iron ski figures are by Robert Boardman Howard. They are both excellent examples of the sculptor's art and the skiers' skill.

The fireplace is a natural rusty iron color, harmonizing with the dark finish of the walls and the rusty red and deep blue of the up-



Photo by Ansel Easton Adams

MARIPOSA LODGE, YOSEMITE NATIONAL PARK—DETAIL OF TABLE ARRANGEMENT

Spencer, Blanchard & Maher, Architects

holstery. The high note is the off white of the indoor shutters, used instead of draperies, and of the French doors.

The exterior is done in the same key, only here the snow itself is the white, the building almost black, window frames dark red. The necessary blue note is found in the sculptural wooden plaque ornamenting the pooka. This also is by Robert Boardman Howard, and shows Zdarski and his straddle-pole down-hill technique.

Mr. Howard has done excellent and most effective work in the Yosemite National Park. The detail from the Camp Curry dining room is a fireplace done by him in yet another medium—slate. The large slabs of native slate are partly chiseled, partly painted in the style of

Paleolithic cave painting. The animals shown are native to the Yosemite National Park. They are sensitively done in the earth colors used by Paleolithic man.

The picture from the Ahwahnee Hotel in the Yosemite National Park is also a detail of decoration. It is the thirteenth century Christmas window done by Jeannette Dyer Spencer which forms the background for the Bracebridge ceremony given in the dining room of the hotel on Christmas day. The ceremony has become tradition at the Ahwahnee. Color of costumes rivals color of window, while Christmas songs create atmosphere for the Christmas feast described by Washington Irving in his Sketch Book.

Also decorative, but smart and new, is the



CHINQUAPIN SERVICE STATION AND LUNCH ROOM, YOSEMITE NATIONAL PARK, CALIFORNIA
Perspective by Robert K. Blanchard



NOTE SIMILARITY OF COMPLETED BUILDING TO MR. BLANCHARD'S PERSPECTIVE OF CHINQUAPIN STATION



GATE LODGE, POINT LOBOS STATE PARK, CALIFORNIA
Spencer, Blanchard & Maher, Architects

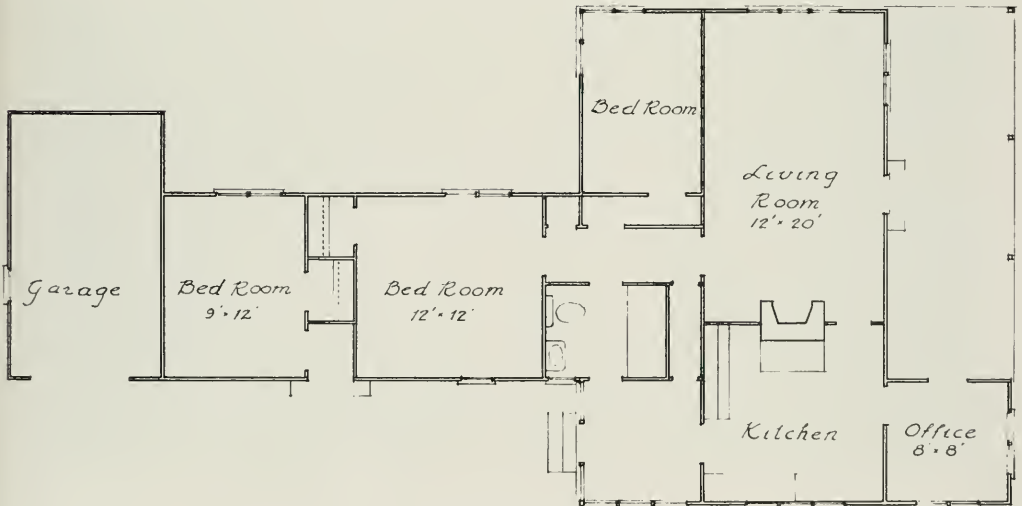

PLAN, GATE LODGE, POINT LOBOS STATE PARK, CALIFORNIA



GATE LODGE, POINT LOBOS, CALIFORNIA
 Perspective Study by Norman K. Blanchard



INTERIOR DETAILS, SHOP FOR WINIFRED GRAY WISE, INTERIOR
 DECORATOR, OAKLAND, CALIFORNIA
 Spencer, Blanchard & Maher, Architects



Photo by Ansel Adams

DETAIL OF CHIMNEY, COTTAGE FOR OTIS R. MARSTON, BERKELEY
Spencer, Blanchard & Maher, Architects

shop of Winifred Gray Wise, interior decorator in Oakland. This is modern roccoco, with emphasis on style. The architecture, painted off white, forms a pleasant foil for the display of rich textiles. It is new enough to

house pleasantly modern furniture severe in line. At the same time the roccoco frames of the mirrors and the stylistic capitals of the columns give Mrs. Wise's collection of fine antiques a friendly setting.



INTERIOR, LIVING ROOM, COTTAGE FOR OTIS R. MARSTON, BERKELEY

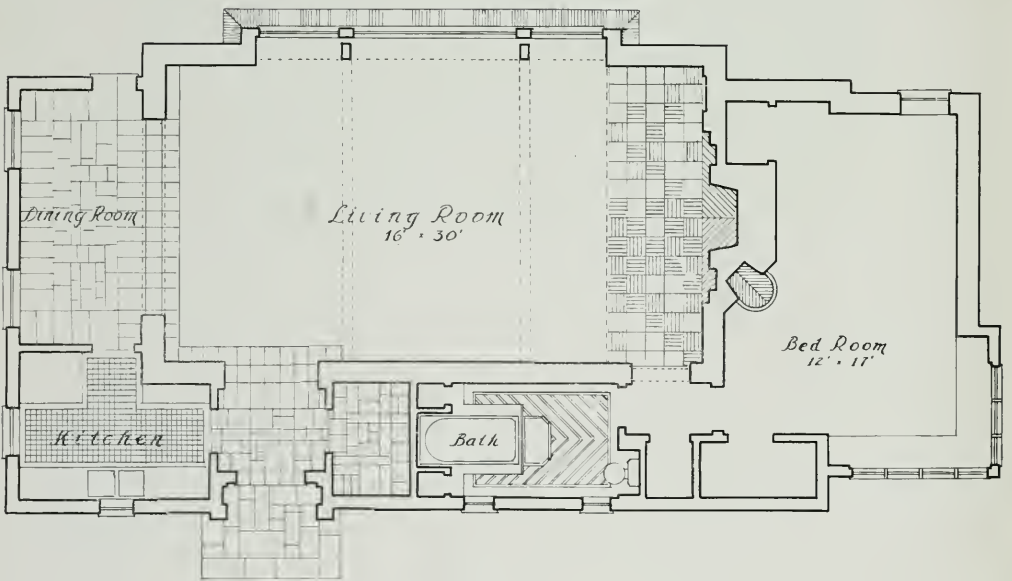

PLAN OF MARSTON COTTAGE

WALBRIDGE RANCH, SONOMA COUNTY, CALIFORNIA



HOUSE CREEK STABLES FOR WALBRIDGE LAND COMPANY, SONOMA COUNTY, CALIFORNIA

Spencer, Blanchard & Maher, Architects

Mrs. Wise's shop and the Walbridge ranch in Sonoma County seem continents apart. They are in mood, but show on the part of the architects the same sensitivity to materials, the same interest in the client's problem. This is a California ranch done by those who love California landscape, its rich lushness in the rain, its extraordinary variety of texture when dry and parched by the summer sun. The illustrations shown are of the stables for the show horses, with the exercise ring in the foreground. The dark, fine foliage of the live oaks contrasts pleasantly with the plain white walls of the buildings, the gnarled branches with the severely rectilinear lines.

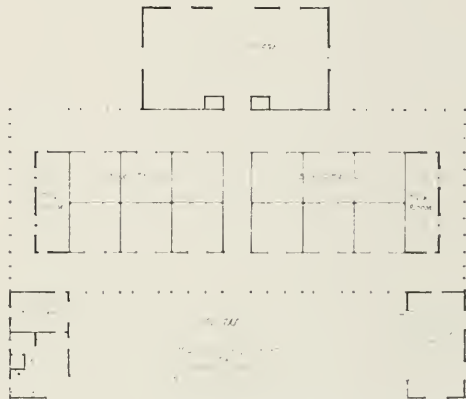

PLAN, HOUSE CREEK STABLES



HOUSE CREEK STABLES, WALBRIDGE RANCH, SONOMA COUNTY,
CALIFORNIA

Spencer, Blanchard & Maher, Architects

CONSTRUCTION OUTLINE

FOUNDATION: Reinforced Concrete Continuous Footings

STRUCTURE: Wood Frame Douglas Fir—Single Board Partitions in Box Stalls—Plywood Paper & Redwood Board & Battens for outside walls of Caretaker's House

ROOF: 24" Royal Cedar Shingles.

CHIMNEY: Patent Flues in Caretaker's House

SHEET METAL: #26 gauge Galvanized

WINDOWS: Outswinging Wood Casements

FLOORS: Douglas Fir in Caretaker's House, Concrete in Tack Rooms, Clay in Box Stalls & Passageways

INTERIOR WALLS, CEILING SURFACES: Exposed Frame in Stables, Plywood in Caretaker's House

HARDWARE: P. & F. Corbin Co.

PAINTING: Exterior—2 coats lead and oil—Interior of Stables, 2 coats lead and oil—Interior of Caretaker's House—Enameled

ELECTRICAL INSTALLATION: Fairbanks-Morse Generating Set—Gasoline Engine, 32 volt generator

KITCHEN EQUIPMENT: Gas stove and Electrolux Refrigerator from fuel from Bottled Butane

PLUMBING: Cast Iron Soil Pipe to Redwood Septic Tank, Galvanized Wrought Iron Seal Water Pipe—Fixtures Standard Sanitary Co.

HEATING: Wood Burning Circulating Heater



HOUSE OF MR. AND MRS. H. L. ADAMS, NEAR CHICO, CALIFORNIA
Henry H. Gutterson, Architect

PLOT AND FIRST FLOOR PLAN

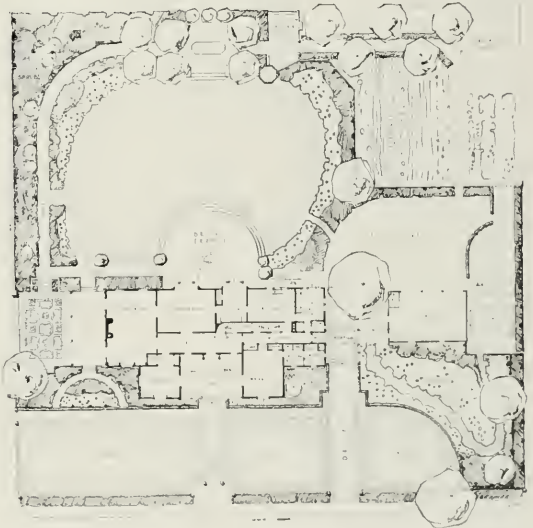

SECOND FLOOR PLAN



TWO HOUSES BY HENRY H. GUTTERSON

IT IS not often an architect is called upon to design a house to fit around trees. More often the trees are planted or transplanted to fit around the house. At Chico, California, Mr. and Mrs. E. L. Adams, clients of Henry H. Gutterson, had a beautiful town property as a center for their pretentious ranching activities.



HOUSE OF MR. AND MRS. H. L. ADAMS, NEAR CHICO, CALIFORNIA
Henry H. Gutterson, Architect



An old building which had served its usefulness as the abode of the owners, occupied an ideal setting beneath magnificent shade-giving walnut trees which protected the house in the summer. When Mr. and Mrs. Adams decided to build they came to Mr. Gutterson with the problem of keeping the trees intact and building the house between them. This was a complicated problem. Calculations for wind stresses and measurements of height and spread of trees had to be taken as well as the maximum sway of the limbs so that no damage would be done to the house in severe wind storms.

How well the architect solved the problem is evidenced by the photographs. First impres-

sion is that the trees were a part of the house program, grew with it, which is just the effect the owners wished.

Because of the warm climate in summer time and cool weather in winter the house is completely air conditioned. The ceilings are insulated with rockwood and fibreboard plaster.

PLOT AND FLOOR PLANS, RESIDENCE OF MR. AND MRS. H. A. IRVING, ATHERTON, CALIFORNIA (See Overpage)



THE ADAMS HOUSE—VIEW FROM PORCH



THE ADAMS HOUSE—LIVING ROOM

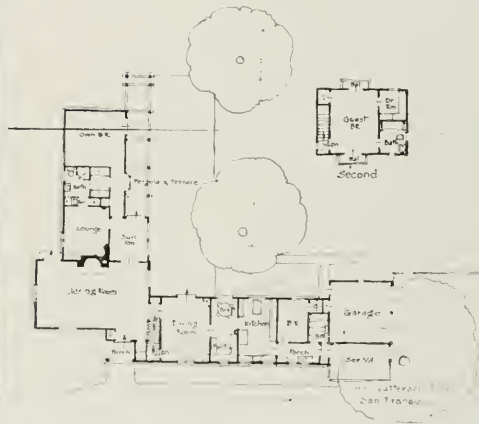

A SUBURBAN HOME FOR THE CITY DWELLER



RESIDENCE OF MR. AND MRS. H. A. IRVING, ATHERTON, CALIFORNIA
Henry H. Gutterson, Architect



THE TREES AND HOUSE SEEM TO BLEND AS ONE



RESIDENCE OF MR. AND MRS. H. A. IRVING, ATHERTON, CALIFORNIA
Henry H. Gutterson, Architect



Provision has been made for out door living in the summer with sleeping porches off the bed rooms, a large terrace leading from the dining room for serving meals in the open, removable sash in the service porch and a protected rear garden. Provision is made for bringing the ranch supplies under cover, an important feature where supplies are handled in large quantities.

All rooms are large and airy. The house has a slate color, terra cotta shingle roof.

The other house of Mr. Gutterson's, illustrated in the accompanying pages, fulfills the needs of

a client who sought relief from the restrictions of city apartment house life to indulge his taste for the country, golf and the company of Peninsular friends. The program called for a house that would provide out of door living beneath the spreading oaks that are so numerous and beautiful in San Mateo County. Provision is made also for a limited number of house guests with protected garden and a country atmosphere in general.

The house is insulated against hot weather with cross ventilation carefully studied and an ample air conditioning plant.



NEW PHILHARMONIC BUILDING, FORMERLY THE AUDITORIUM,
LOS ANGELES

Claud Beelman, Architect

CO-ORDINATION OF THE BUILDING INDUSTRIES

By CHARLES M. CADMAN

President, Pacific Coast Aggregates

THE purpose of my address* today is to impress upon you the necessity of having a well co-ordinated group in the construction industry. Indeed, I think it should be called the "All Construction Industries Committee," because of the fact that we are at the present time working in many directions to reach the same goal, but giving no thought to the necessity for proper control of advertising, with the idea in mind that a study of this problem should contemplate protecting the interests of the architects as well as engineers, materialman and all those related to the construction industry.

We must take this job with the idea that it is a simple case of "one for all and all for one." If we do not do that, I am satisfied that the Federal Government will take the reins and do it for us and I think it would be a most unfortunate thing to have the control of our industry pass out of our own hands.

I call your attention to the government's demand that we, of the industry, take the lead in getting the money into circulation in the form of governmental insured loans. Since they have set out to bring about a speedy recovery of our business, there is no question but that the government will do the job for us if we fail.

In considering the subject I am reminded of the famous remark which Mark Twain made about the weather. He said that the weather was one thing which everybody complained about a lot, but no one ever did anything about it. I think all of us who may be connected with the building industries will agree that there has

not been a great deal more done to improve the industry than there has the weather.

However, it is encouraging to note that this comparison carries along even in the present day. The air conditioning people have started to do something about the weather, and it is possible to discern activities in the building industries which are hopeful portents for the future.

Before discussing these current co-ordinating activities, it might be well to examine our problem, and determine as precisely as possible the facts in relation to it. This, I believe, is the method which you gentlemen would pursue in undertaking a project of any sort.

Following this procedure, let us find out what "co-ordinating" really means. The dictionary says:

"To co-ordinate—is to arrange or harmonize, or to combine for the common purpose of action."

Proceeding, we next encounter conditions which are so familiar to most of us that they are taken as a matter of course, but which, from an outside point of view, are quite amazing.

In the building industries, there are over forty specialized groups represented, and it is necessary to bring together an intricate combination of these groups to produce a completed structure. As I said before, this is taken as a matter of course by all of us, and the architect particularly has to spend much time and

* Delivered at the annual convention of the State Association of California Architects, Fairmount Hotel, October 14, 1938.

energy in training himself to deal with the problems inherent in this complicated setup.

Unfortunately, as we all know, there are realistic conditions which have prevented the architect from exercising his professional abilities in co-ordinating all construction activity. With this recognition of the fact, we may now proceed to the consideration of other aspects of the problem.

Let us for a moment consider the historic position of the construction industry in relation to both the business and social fabric of the country. For many years we were second only to agriculture in dollar volume and in the number of workmen employed. In recent years, the industry of distribution, comprising retail and wholesale trade, has crowded construction into third place. In the latest figures released by the United States Department of Commerce, agriculture is credited with approximately 10,600,000 workers; distribution with 6,500,000, and construction about 3,100,000 workers. The average annual values in these three groups from 1920 to 1930 were \$11,200,000,000 for the farms; \$11,600,000,000 for construction, and \$105,000,000,000 for retail and wholesale trade.

This, of course, is past history. I do not need to produce detailed statistics to impress upon you the present deplorable state of our industry. It would be futile to spend any time in discussing this question unless such discussion would lead to concrete plans for improvement.

We, in the industry, are quite well aware that the respected demands of the public for houses produced by mass production methods are at present quite impractical. This is no excuse, however, to sit back and do nothing. It requires very little study of our extremely complicated industry to realize that tremendous progress can be made in the co-ordination of the diverse units. Many attempts have been made to secure a more definite adhesion between construction units. Builders' exchanges, trade associations, and other similar groups are in existence, but all of these organizations have been horizontal ones, extending along specific

trade lines of cleavage. There has never been a completely integrated, vertical co-ordination which would affect equally the entire industry from top to bottom. And it requires very little objective consideration of the problem to see that such a vertical integration is the only type of industry-wide co-ordination which will solve present day problems, particularly in the important field of residential construction.

It is true that only recently has the financial setup made such an integration possible. The organization of the Federal Housing Administration in 1934 provided for the first time in construction history a vertically integrated plan for financing construction of all types. By following along the trail which the F.H.A. has blazed into virgin territory, it is now possible to plan industry co-ordination of the proper pattern.

In recent months here in San Francisco, we have been endeavoring to do precisely this thing. When first we began to discuss the problem, we discovered that a comprehensive organization going through from top to bottom, and with an equal and authoritative interest in all levels of activity, was necessary. We found in the San Francisco Chamber of Commerce an organization pattern which we believe will fulfill this purpose very successfully.

I might say that we tried in vain to find an organization that could act for the construction industries. We could not use the smaller trade associations, and in the decision to use the Chamber of Commerce, we felt that the success of the Committees in Los Angeles, Cleveland, and Philadelphia justified our following their course, and I am urging consideration of this body of the idea and that you go to your respective cities and endeavor to have some similar medium which will be a common meeting ground where you can get public support.

May I call your attention to Mr. William Merchant's chart, in which he so ably demonstrates by the use of the turbine engine that the oil to lubricate the machine comes from the owner or the lending agency with the loan guaranteed by the Federal Government. Please note that nearly forty allied industries are involved in the

flow of energy and the finished product as shown on the chart indicates employment for all the building mechanics who are qualified to accept employment.

Has it not occurred to you that much of the advertising in the building industry is badly directed when it comes to a question of benefit to the industry as a whole? I am convinced that through the meetings of the Construction Industries Section, the cement, plumbing, glass, paint, and other divisions could arrange for the expenditure of advertising funds to much greater benefit for each and every branch of the industry.

There has been organized a Construction Industries Section of the Chamber, completely autonomous and self-supporting, but using the facilities and prestige of the Chamber to carry through the initial period, until it has gathered sufficient momentum of its own. This Committee has invited representatives from all of the construction interests to join its work. It has worked out a carefully planned organization, and in connection with the Federal Housing Administration, is about to embark on a campaign specifically designed to interest the public in building. This campaign will undoubtedly result in greatly increased interest on the part of the public, and increased activity of all groups in the industry.

Some of you gentlemen are familiar with the details of this campaign, as you have been participating in work of the Section, but there is another phase of the Section planning which I wish to take up and elaborate upon at this time. The Construction Industries Section has charged itself, not only with the duty of meeting the immediate needs of the public, but also in planning the future welfare of the industry. We hope to use the methods of modern scientific research in studying present conditions in the industry, with the expectation of planning future activities which will restore construction to its rightful position in the industrial fabric.

Our own immediate problems are obviously well known to all of us, and to a very considerable extent we have made every effort within our

immediate power to overcome these problems. However, all of our thinking and observation has been introspective, concerned only with our reaction to the conditions we encounter in our daily work. It is quite important that we should take an objective long-range view of conditions, for the same reason that a vertical coordination of industry is the desirable one. It is very easy to get into a mental rut whereby we are concerned only with things in the foreground, and are no longer able to see the forest for the trees. Let us look through the other end of the telescope for a moment, and see what our industry looks like from the outside, from the point of view of the consumer, who is only interested in living in a house—not with building one.

To most men in the building industry, this brings a very bewildering change in perspective, but to orient ourselves in this new and strange land, we need only to forget for the nonce that we are architects, or materialmen, or anything else, in the building industry, and remember only that we are consumers. Every one of us is a consumer. It is so much a matter of course to use a telephone, buy a newspaper, or have lunch in a restaurant, or purchase a new necktie, that it never occurs to us to consider that our attitude as a consumer of these daily needs is precisely the attitude that is taken by the consumer who buys a house. The industry of distribution—the wholesale and retail trade—has shown a striking growth in the last few decades, primarily because the men engaged in this industry have been keenly aware of the point of view of the consumer.

Keeping this in mind, they have developed the art of mass selling to a high degree, with the science of mass production following in its wake. Today, the consumer seldom buys—he, or she, is always sold.

Statistics tell us that women purchase 85 per cent of the merchandise sold at retail. Did you ever follow your wife or your sister through an afternoon of shopping? She may visit a score of retail establishments and come home only having purchased a spool of thread, but she has been exposed to millions of dollars'

worth of high-grade selling. And every store she has visited has expended considerable work and money in appealing to her desires, simplifying her choosing, and delivering the completed package, with the least effort on her part. A department store may have forty departments, selling merchandise from all the Seven Seas, but the entire institution exists for but one purpose—to enable every woman to secure whatever may appeal to her desires, with the minimum of time and effort. And this modern merchandising technique has been in use for a sufficiently long period for practically every woman in the country to become completely accustomed to its operations.

Let us now turn our consumer searchlight on the building industry. We find a complicated and highly technical mess, with only a few large consumers able to pay for the professional guidance needed. The average consumer, making up the great mass market, does not encounter a modern and skillful merchandising approach designed to part him from his dollar as easily and painlessly as possible. Habituated to this streamlined method of buying, she decides that a new home is too much trouble, and switches to a fur coat, or a new automobile.

What can be done about it? We cannot expect to change the buying habits of a nation, or upset the technological limitations of our production. Yet we have a tremendous potential market, unlimited financing, and an industry eager to go to work. Logic forces the conclusion that the one factor under our control which can be changed is our selling approach—and common sense indicates clearly that this is the one thing we should change.

Of course, the cry immediately goes up: It can't be done! Let us reverse the telescope again, and take another look. Suppose we turn to our definition of "co-ordinate" again. It says: "To combine for a common action." What action could be more "common" to the entire industry than selling our joint merchandise? No consumer wants to buy a house without a roof over it, or a bathtub without a bathroom around it. Is there any good sense in forty different sets of salesmen selling one purchaser single piece of merchandise? Tradition in the building industry says it can't be done, but the automobile, the electric refrigerator, the department store, all prove every day that they are right, and tradition is asleep at the switch.

Other questions that might be raised are purely incidental. Competition is no longer from within, but from without the industry. And if we have brains enough to unscramble a set of plans and specifications for a structure, we certainly ought to be able to allocate the selling cost equitably. And, finally, the strongest argument for modernizing our industry selling methods is the impelling one of necessity. We are not selling houses today. If the industry is to keep its independence and escape the growing pressure for governmental regimentation, it **must** modernize its merchandising to compete with the up-to-the-minute methods to which the public has been trained by our competitors, who are today in all other industries outside our own competing for the consumer's dollar.

And that, gentlemen, I submit is the real goal for which we should strive in co-ordinating the building industries.

AN ANALYSIS OF THREE TYPES OF HOUSE INSULATION

By J. R. VON STERNBERG, R. A.

WITH the development of modern insulating and heat-stopping materials over the last fifteen years has come a confusion of terms and claims that leaves the average home owner, builder and building manager bewildered and asking, "What kind of insulation—storm sash, weatherstripping or wall and roof insulation—will do the most for my house?"

Unfortunately, no general rules apply to all cases. To calculate exhaustively the heat losses from any one insulated building, estimating the cost of material and labor and the probable value of the fuel savings effected, will not solve the insulation problems of all houses. For everyone appreciates that a house in Northern Minnesota has a far different insulation problem than one in California. There may also be a considerable difference between two houses on the same street, due to differences in exposure, construction and room arrangement.

Nor can insulation's benefits be fairly compared on a first cost and return basis, although the cost of any building product will naturally be a factor in its use. Obviously, a man who spends \$15 for a suit pays a heap sight less than the man who spends \$50, and still the cheaper suit may prove to be the poorer bargain.

Insulation, besides reducing fuel costs in winter, however, is designed to improve comfort. Thus the first judge of insulation should be com-

fort. In winter, maximum comfort means maximum protection against loss of heat. In summer, maximum comfort means maximum protection against outdoor heat. These two objectives, then, winter and summer comfort, provide a fair basis of comparison of all insulating and heat-stopping materials.

But of the three types of insulation—storm sash, weatherstripping and wall and roof insulation—only wall and roof insulation provides any summer protection. Let us then consider the winter protection that each provides:

In winter, a house will lose its heat in several ways: Through its openings, such as windows and doors, and through its walls, floor and roof.

Weatherstripping, storm sash and double-glazing prevent loss of heat through openings, while insulation prevents heat loss through walls, floor and roof. Occasionally, both window and wall insulation are desirable, while at other times only wall insulation is thermally practical. Following is a brief discussion of the relative effectiveness of these different materials:

Weatherstripping is a window seal. All windows leak cold air into a house around the sash and around the frame where it joins the wall. Weatherstripping will help seal the sash of the window, and caulking will help seal the frame.

The Guide of the American Society of Heating and Ventilating Engineers shows that poor

windows, when weatherstripped, will admit about 10 per cent less cold air than well-fitted, or average, windows not weatherstripped. Weatherstripping a tightly-fitted window will reduce its infiltration by about 30 per cent.

Storm windows and double-glazed windows are also good heat-stops. The addition of an extra thickness of glass provided by storm sash

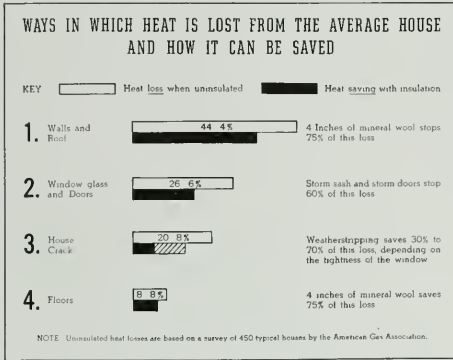

reduces the heat lost through the glass by about 60 per cent. Storm sash, when applied over poor, or loose-fitting windows, also provide some weatherstripping action. When windows are very loose, this reduction may be as much as 50 per cent of the infiltration.

But when storm sash are applied to average fitted windows very little reduction in infiltration is secured.

Windows in the average house, however, occupy only about 10 per cent of the total wall area. Reducing this heat loss does not reduce the substantial heat loss through the walls, floor and roof of the house. This loss, quite naturally, can be effectively reduced only by means of wall and roof insulation.

It can be seen, then, that in order to estimate the relative effectiveness of each of these types, it is necessary to know what share of the total heat loss is saved by each.

In an effort to indicate this relationship, the

American Gas Association conducted a survey of heat losses from 450 typical houses and arrived at the following average heat losses:

1. Loss through walls and roof, 44.4 per cent.
2. Through floors, 8.8 per cent.
3. Through cracks, 20.8 per cent, and
4. Through glass and doors, 26 per cent.

These figures represent only average losses. While they may not apply to every house, most houses, on the other hand, will lose their heat in the given proportions, no matter where they are located in the heating belt.

Taking these averages, and calculating the percentage of each saved by its respective insulation, we find that the following materials will give maximum protection against each of the four heat losses listed by the American Gas Association.

1. Four inches of mineral wool in side walls and second floor ceiling will effectively reduce the loss through walls and ceiling by about 75 per cent, or the total loss by 33 per cent.

2. Weatherstripping of windows and door crack by 30 to 70 per cent, or 6 to 15 per cent of the total heat loss, depending on how well built the window is.

3. Storm sash and double-glazed windows will reduce the heat loss through average windows by about 60 per cent, which represents 16 per cent of the total heat loss.

4. Four inches of mineral wool installed in lower floors will reduce the heat loss through them by 75 per cent, or the total heat loss by 6.6 per cent.

These figures may serve as a general guide to the home owner planning to install one or more heat stops in his home. His final judgment should be weighted, however, by not only these percentages, but by reference to the state and exposure of his house. In this way he may determine his precise insulating needs.



LIGHTS INSIDE AND OUT GIVE THIS HOME AN ATMOSPHERE OF FRIENDLINESS AND CHARMING INFORMALITY THAT FULLY EXPRESSES THE SPIRIT OF THE SEASON

YULETIDE OUTDOOR LIGHTING

By A. M. BARRELL

CALIFORNIA'S midwinter festival of holiday lighting has grown to be one of the State's major festivities in the twelve years since the Outdoor Christmas Tree movement was inaugurated.

Each year has seen an increasing number of homes, commercial buildings, public buildings, parks, and miles of trees along highways transformed into a dazzling, sparkling, holiday world with millions of gaily colored lights.

This year the movement promises to take the state by storm, with the California State Chamber of Commerce as sponsor, and with municipalities everywhere joining the program. Literally miles of living trees will soon be ablaze with glittering lights.

One of the most pretentious displays will be twenty-five miles of living trees lighted on the highway from Santa Cruz through the San Lorenzo Valley, under the auspices of the Christmas Tree Association there.

On the Redwood Highway in Dyerville



SIMPLICITY OF DESIGN AND COLOR IN KEEPING WITH THE ARCHITECTURE WILL BE NOTED HERE. FIVE CIRCULAR ROWS OF GREEN LAMPS FORM THE WREATH



ARCHITECTURAL INDIVIDUALITY TAKES ON NEW AND BREATH-TAKING BEAUTY WITH HOLIDAY LIGHTING



DIGNITY AND SIMPLICITY OF LIGHTED DECORATIONS GIVE THIS ENTRANCE AN AIR OF WELCOME AND GOOD WILL

Grove, the tallest tree in the world, 368 feet high, will be lighted. Another giant tree, the "Nelly Atkinson," near Scotia, will also be lighted. This tree is 220 feet to the first limb and this distance will be floodlighted. Both trees are so tall that professional tree toppers are employed to string the lights.

Many cities throughout the state have their "mile of lighted Christmas trees, which may mean anything from a mile to twenty-five miles. Fresno has two miles. Hayward has planted a mile of Christmas trees on the highway toward Niles. Sacramento, Roseville, Fortuna, and Gilroy, have each planted a mile of Christmas trees while San Jose, Chico, Davis, and many other California cities have started their mile of tree projects.

Various clubs and organizations as well as scores of newspapers throughout the state, have announced contests in which individual homes are decorated to compete for valuable prizes. These contests have proved tremendously popular in California cities as this holiday lighting presents almost unlimited opportunity for the family to plan and execute original ideas where their imagination and ingenuity can run riot in a blaze of colorful lighting. This is one time of the year when we can share the loveliness of our homes and gardens with the world at large.

Much of the decorating is done with festoons of multi-colored lights exclusively, the strings arranged on trees or shrubbery, outlining entrances, eaves, windows; bordering walks, or fountains. The outlining festoons are particularly attractive when the lights are combined with leaves or evergreen twigs.

Silvered trees or trees decorated in ornaments all of one color are particularly effective when floodlighted from two or three different angles, as they then stand out in striking relief from the surrounding blackness.



APARTMENT DWELLERS LITERALLY SEE THEIR BUILDING IN A NEW LIGHT WHEN HOLIDAY DECORATIONS ADD A NOTE OF WARMTH AND CHEER

There are a number of new materials available for use in outdoor decoration, such as crinkled or flat aluminum foil, composition board, translucent fabrics, colored cellophane, and various glasses. These may be combined and used with light to create scores of designs such as stars, toy figures, wreaths, bells, or anything else that suggests itself. Crumpled cellophane, formed in balls around the colored lamps in Christmas tree strings, and with artificial leaves added, create clusters of iridescent flowers.

If any proof were needed that California has lost nothing of the spirit of light-hearted gaiety and hospitality for which its early days were famous, it is furnished during the Christmas holidays when each year sees this spirit expressed more and more by means of lighted outdoor Christmas decorations.



THE HARWELL HAMILTON HARRIS house, Los Angeles, designed by the owner, has a repose and simplicity characteristic of the Orient, and suggests Japanese work in the use of natural colored materials, a module unit, in this case three feet, and sliding panels. The walls are of natural redwood, the lighting cornice over the doors of natural white pine and the ceiling of Celotex insulation board. The translucent material of the sliding end panels is of waterproof cloth applied with wax and a hot iron, while the center panel has flyscreen. The floor is covered with Chinese grass matting in twelve inch squares, with the weave running in different directions. The furniture is of teak. A splash of color is given to the room by the richly embroidered covering of the couch.

ANTE-BELLUM HOMES

By P. J. RINDERLE

IN THE years immediately following the acquisition of Louisiana by the United States a steady stream of artisans, merchants, bankers, speculators and adventurers flowed into New Orleans from all over the country and proceeded to share in the great prosperity that engulfed this region prior to the Civil War. The original city, now known as the Vieux Carre, contained the business and financial heart of the community, but with the coming of the Americans the influence of the Creole diminished and the balance swung to the other side of Canal Street where the newcomers built their shops, banks, theaters and hotels. What began as a trickle soon grew into a torrent and in the decades between 1830-60 the Vieux Carre was well on its way to becoming largely a picturesque section of the growing city. Just as the Americans ignored the Vieux Carre from a business standpoint, so they refused to build their homes within it. As clannish as the Creoles, they established several suburbs outside the city, the most famous of which was Lafayette, embracing nearly all of what is now known as the Garden District.

Today this district is famous throughout the country for the unique architecture of its beautiful ante-bellum mansions. Built at a time when prosperity was at its peak, these homes, according to Nathaniel C. Curtis, "represented the highest expression in domestic architecture that the wealth and talent of the day could produce." As habitable today as when constructed seventy-five to a hundred years ago, the manner in which they have withstood the vicissitudes of time is a striking testimonial for the sound methods of the old-time builders. Increasing the attractiveness of the homes are the numerous trees, the flowing vines and the

green shrubbery which are everywhere in evidence on the spacious grounds and which, because of the contrast with the Vieux Carre's picturesque congestion, inspired this section to be named the Garden District.

Curiously enough, a flood played an important part in developing this section. In the spring of 1816 a crevasse in the levee above the city, one of the last ones to take place in New Orleans, flooded the surrounding territory, including the extensive plantation holdings of Francois Livaudais. Upon the subsidence of the waters Livaudais was astounded to find three to four feet of river sand blanketing his rich, black earth and dooming it to idleness for several years. While contemplating this prospect he was approached by a group of spectators who, realizing that the added elevation and the porousness of the sand were conducive to good drainage, desired to lay out streets and lots on his property. Livaudais agreed, and the project proved immensely successful.

First Home Still Stands

Probably the first to build in this new residential section, at least his home is the oldest one in existence, was a Thomas Toby of Philadelphia who chose a type of architecture not ordinarily followed in subsequent years. This was the raised cottage, indigenous to Louisiana, and designed to lessen as much as possible the inconvenience of floods. Thomas Toby's house was built on Prytania and First Streets and still stands. It is a two story structure with the bottom floor used as a basement. Access to the deep porch that extends on three sides of the house is by a graceful stairway with curving balusters broken in the middle to allow entrance from the side. The roof which is flat and covered with slate is surrounded by a plain entablature.

ture supported by square, wooden columns. The windows, tall and comparatively narrow, are in the French style. Set in the midst of beautiful foliage the elegant white structure is exceedingly appealing in its classical simplicity.

Scattered throughout the city are several other homes of this type, although they are more commonly found in the country parishes. Notable examples of this unique architecture are the Stauffer home in Metairie Lane and Chaffraix Cottage in St. Charles Avenue, the former built well before, and the latter during, the Civil War. An interesting feature of the Stauffer place is the balustraded space atop the sloping roof used in olden times as a lookout when floods were anticipated. The roof in front is broken by two dormers while the flat side has a solitary window with an arched top and flanked by pilasters. The columns of the second story porch are circular and have simple doric capitals. The Chaffraix Cottage is a misnomer—it is nearly a mansion. Built in the 1860's by Mrs. Shephard Brown who was ousted from her Garden District home by General Butler, it is a fine type of the French colonial raised cottage of the Greek Revival period. White, constructed mainly of plaster-covered brick, it has a deep, irregular front porch with Corinthian columns. The windows of the second floor are long and narrow, harmonizing with the typically high ceilings. The roof, flanked on each side by three tall chimneys, has three dormers with pediments and pilasters. Both the Chaffraix and Stauffer homes have well kept grounds whose brilliant greenery offset pleasingly the glaring whiteness of the buildings.

Nineteenth Century Home

A different type of ante-bellum architecture, one in the main confined to the Garden District (bounded by Jackson Avenue, Magazine Street, Louisiana Avenue and St. Charles Avenue), is that which arose around the middle of the nineteenth century when great interest was manifested in Grecian archaeological discoveries and simulation of Greek architecture became the vogue. Yet these Greek Revival homes are by no means purely classical. Rather, the Greek influence indicated itself in such things as the

profiles of the mouldings, the designs of the ironwork, the doorways and, in general, the ornamental features of the houses. In some cases, the home boasted a formal portico in the front with great care taken that its dimensions were correct and the proper symmetrical effect achieved.

In time, two classes of people came to populate the Garden District; the so-called merchant princes—Americans whose habitation in New Orleans was comparatively recent and who were carrying on a tragi-comic feud with the Creoles; and the wealthy sugar planters who already had magnificent places on their plantations but desired also to have city houses for the accommodation of themselves and their many relatives. Both classes had much money and they spared no expense in building. As a result, the thirty years prior to the Civil War saw more building on a lavish scale than any other comparable period before or since, and the brunt of the construction took place in the Garden District.

The Garden District House

Although there was a good deal of similarity in the construction of these homes, largely because they were built at the same period and were laboring under the same architectural influence, nevertheless each possesses an individuality of its own, reflecting the tastes and personality of its builder. In general, however, Garden District homes are two stories in height and raised several feet off the ground. They are roughly L-shaped, the wing in which the servant quarters, kitchen and store-rooms are located being lower than the principal part of the house. Construction is of brick, covered with cream-colored plaster. Plainness of the smooth sidewalls is broken by galleries with cast iron railings and two tall chimneys over the simple parapet.

Imposing as are the exteriors of these mansions, the real elegance is in the interiors. If, as in many cases, the entrance is at one end of the colonnaded porch, there is a long hallway leading to a spacious dining room to the rear and flanked on one side by an oblong drawing room. This room, often called a "double-par-

lor" because of its division by an arch or sliding doors, is the most impressive feature of the home. The floor, of a heavy, resistant wood, is highly polished and mirror-like. Each division of the double-parlor is identically treated in its permanent fixtures, the most prominent detail in each being the beautiful mantels of white Italian marble surmounted by full-length mirrors enclosed in gilt frames. From the sixteen to eighteen foot ceilings hang two or more crystal chandeliers in harmony with smaller wall lights, the myriad lights of which are reflected in flawless mirrors and give an appearance of fairyland. The room is furnished in period furniture, the excellent rosewood and mahogany pieces of masters such as Seignouret and Mallard.

Rising from the floor of the hall is a long stairway with mahogany balustrade. The stairway in some cases extends to the second floor in an unbroken line, but in others is composed of two flights set in a graceful curve or at angles to each other. The second floor is given over exclusively to living quarters for the family although one room might be set aside for the lady of the house to receive intimate friends or to use in whatever way she sees fit. The rooms are exceedingly large and are furnished with massive four-poster beds, mahogany armoires, and smaller pieces. The windows again are long and narrow, and in some cases give access to a small porch decorated with ornamental iron work and supported by artistic brackets.

To facilitate drainage the houses are built on ground raised a foot or so above the natural level and held back by a concrete or granite curbing which serves as a base for the heavy, ivy-covered iron fences. The grounds in nearly every case are spacious and given over to informal gardening. Shrubbery, usually of the flowering variety, was preferred to flowerbeds, and numerous trees, some small and some large, were planted here and there. Although live oak is occasionally seen the perpetual shade beneath its spreading branches prevented plant growth of any kind and the magnolia, huckleberry and sycamore were more commonly em-

ployed. But the forte of these old homes is the various species of vines, purple bigonia, morning glory, Virginia creeper, rosa montana—that climb along the side of the house, entwine themselves in the ironwork, twist around the pillars and overhang the fences

Modern Structures Replace Old Ones

The Garden District embraces quite an extensive area and in the hundred years and more of its existence many changes have taken place within it. Several of the original homes have been torn down to make way for more modern structures, others have been converted into apartment houses, asylums and commercial establishments, and many have been destroyed in various ways. The finer homes were built on the streets running with the river such as Chestnut, Coliseum, Camp and Prytania and the principal cross streets—Jackson, Louisiana and Washington Avenues.

One of the most beautiful homes in the Garden District is situated at Coliseum and Fourth Streets and was built in the 50's by Julius Koch. It is interesting also from a historical standpoint as it was the home of James B. Eustis, United States Senator, and in 1876 appointed by Cleveland to be first ambassador to France. It is not, however, a typical District home, its architecture showing more English influence than Greek. Irregular in shape, it has numerous projections and steep gables. The V's of the gables are fringed with ornate wood carvings and serve as coverings for small, enclosed porches. Following the outline of the house on the second story is an open gallery lined with a cast iron railing. The well-kept garden is enclosed by an iron picket fence.

On Louisiana Avenue near Prytania is a large white residence, built along the lines of a Louisiana plantation home, known as the Freret Mansion. It was built in the 50's by James P. Freret and its great size is understood when one remembers that the Freret family of seventeen boys and girls were reared within it. It is a two story structure with no outside stairway and the bottom floor set flush with the ground. The second story porch is fringed with a wooden

(Please turn to Page 48)

“Full Support and Endorsement”

of THE ARCHITECT AND ENGINEER and ARCHITECTS' REPORTS by the State Association of California Architects is evidenced in the following resolution passed at the 1938 S.A.C.A. Convention.

Whereas: The State Association of California Architects desires to renew its faith in “The Architect and Engineer” and make expression of good will existing between itself and this publication. Therefore be it Resolved: That the Association in the Eleventh Annual Convention assembled in San Francisco, October 13, 14, 15 gives its full support to the endorsement of “The Architect and Engineer” and “Architects' Reports” and goes on record as being in complete sympathy with the editorial aim of this publication.

Here is evidence indisputable, of the acceptance, confidence and support enjoyed by this publication from the professional field it serves. Naturally this reader interest and coverage redounds to the benefit of producers utilizing this medium to publicize their building products.

A major factor in the established acceptance of THE ARCHITECT AND ENGINEER as NUMBER ONE PUBLICATION IN THE WEST COAST BUILDING FIELD.

The ARCHITECT and ENGINEER **Architects' Reports**

68 POST STREET • SAN FRANCISCO

“Thirty-three Years of Continuous Publication”

World's Fair Builders

JESS STANTON

FOR a man his size, Jess Stanton is pretty soulful in a two-fisted way. He's a third-generation San Franciscan. His grandfather came west in '48, before the gold rush, and they say he died of gold fever without ever getting his hands on Golconda.



J. E. STANTON
Director of Color, Golden Gate
International Exposition

So, when Jess Stanton came to work for the Golden Gate International Exposition eighty-nine years later, he thought back on his thwarted grandfather — subconsciously. He glorified acres of stucco with gold mica, bringing the fabulous glitter of the gold fields (as his grandfather must have dreamed them) to Treasure Island.

Probably Stanton didn't intend this, exactly. What he meant to do, he accomplished as well — an iridescent surfacing as distinctive as travertine was in 1915, and useful in the World's Fair night scene. The gold mica will squirt sparks like a million blacksmiths when the lights

go on; there'll be such beauty as never was seen at a World's Fair, and you can thank Jess Stanton. He's responsible for the color by day, and the lights by night. His insistence and steadfastness that the horticulture should be unsurpassed has seen this dream garden come true.

You can thank Hermann Bosch, master plasterer, also, for the gold mica. He and Stanton, in cahoots, perfected this trick of turning their buildings "inside out" to make them sparkle, shimmer and glow like lighted alabaster. You'll see.

Stanton was born in San Francisco; went to art school, and switched to architectural designing by preference. He started with Bernard Maybeck, and in 1903 joined Albert Pissis, architect, of San Francisco. After the fire he was chief designer in the city architect's office until 1909, when he went to Chicago to work on the "Chicago Beautiful Plan" under D. H. Burnham for two years.

On to New York for Warren & Wetmore, he had a hand in the Commodore and Biltmore Hotels on Manhattan, in several of the Ritz Carltons, and so forth. Back in San Francisco for three years with Lewis Hobart, on to Chicago for three years with Graham, Anderson, Probst & White. Stanton helped form the Allied Architects' Association of Los Angeles, the first group of architects in America to associate for public works, and was in charge of its program from 1920 to 1925.

Then he became architectural advisor and consultant of color for Gladding, McBean & Co. In developing their decorative tile and ceramic program his enthusiasm for color came topside, and in 1937 the Western World's Fair nabbed him to harness the rainbow on 24-hour duty. He promptly junked the rainbow in favor of California wildflowers, so Treasure Island has a color palette of pastels that are not too sweet, but beautiful.

Jess Stanton has exhibited his watercolors for years, in many cities, and now he's doing watercolors by the acre with water-mixed paint in the inner courts. He still prefers outdoor painting above all things, prowling the high-centered desert roads of the Southwest in search of surviving Spanish and Indian an-

tiquity. In the city he prowls the Bohemian Club.

Of all the "men who" at the Golden Gate International Exposition, Jess Stanton is most exposed to the fire of artistic snipers. He's the man, under W. P. Day's okay, who puts the frosting on the cake—the gay cosmetics on the honest countenance of Treasure Island. Few will criticize the three-hinged arches, but every Tom, Dick and Harriet will have a loud opinion on Treasure Island: Is it beautiful? That's why Stanton has lost thirty pounds on this job, making the "ayes" have it.

ANTE-BELLUM HOMES

(Concluded from Page 45)

railing with rotund balusters and is divided by large Doric columns. The porch is supported by square brick tiers running to the ground and forming a veranda. The gently sloping slate roof is broken by two dormers having arched windows.

At the intersection of Camp and First Streets is an imposing edifice, a fine example of Greek Revival architecture, and interesting historically because in one of its high-ceilinged rooms, Jefferson Davis, president of the Confederacy, died. It is two stories in height excluding a high attic, built of brick and stucco, and has a porch with cast iron railings on each floor in the front. Like many Garden District homes it is raised several feet off the ground and has a short, unpretentious central stairway. The graceful columns of the bottom porch are of the Ionic order and the upper a modified Doric. Not often seen are the high parapets on either side of the house which serve to hide the V-shape of the roof.

Throughout this park-like section of New Orleans are dozens of other houses worthy of note by not only the architectural minded visitor, but by everyone who enjoys the beautiful and the unusual. Although much of the original beauty has been tempered by the hand of time, what it has lost in freshness it has made up in homely charm. And, in spite of an insidious commercialism along its fringes it still remains the exclusive neighborhood that it always was, for this peaceful section with its solid homes and stately trees and verdant shrubbery defies

NORTHERN CALIFORNIA CHAPTER

The regular monthly meeting of Northern California Chapter, A. I. A., was held at the St. Francis Yacht Club, Tuesday evening, November 29, Warren C. Perry presiding.

PRESENT: John Bakewell, Jr., John Knox Ballantine, Jr., Arthur Brown, Jr., Edward R. French, Jr., Wayne S. Hertzka, Lester Hurd, Lawrence A. Kruse, James H. Mitchell, Irving F. Morrow, Warren C. Perry, Ernest E. Weihe, Alfred C. Williams, Wm. Wilson Wurster, Raymond W. Yelland.

GUESTS: Messrs. Loring Rixford, Jesse E. Stanton, Ralph Stackpole, Shepard Vogelgesang.

There being no business the meeting was turned over to Mr. Bakewell, Chairman of the Fine Arts Committee of the Chapter, who had arranged the program. "Decorative Art at the Golden Gate International Exposition," was announced as the subject of the evening.

The first speaker was Shepard Vogelgesang, Assistant Director of Decorative Arts and Director of Design for Fine Arts. He told of the general group divisions of the Fine Arts Exhibit and outlined the material each would contain. He also explained the inner arrangement of galleries to accommodate the vast quantity of material that will be displayed and how many of the problems that had been encountered had been met. It was readily foreseen from his talk that the Exposition will be graced with the most outstanding collection of art that has ever been housed in this country in one collection.

Ralph Stackpole, noted sculptor, spoke on the sculpture of the Exposition and drew a comparison of it with that of the 1915 Exposition. Probably the most interesting part of the talk was his description of the construction of "Pacifica" as an example of the difficulties encountered in temporary work as compared with those of a lasting nature.

Jesse E. Stanton, architect in charge of Color, explained what the color scheme of the Exposition will be, and how it is being developed. The bay site, water background, grey days and fogs were fundamental factors in determining this selection.

Arthur Brown, Jr., Chief of the Architectural Commission, dwelt on the coordination of the various arts of sculpture, painting and architecture in the Exposition. The buildings, simple in line, form and color, he explained, will be bathed and immersed in a colorful planting scheme, combined with night lighting that in itself will be an exposition of the great development in this modern field.

At the close of the program a vote of thanks was extended to the speakers.

Loring Rixford, past member and former City Architect, acknowledged his introduction and expressed pleasure in again meeting with the Chapter.—J. H. M.

change and promises to be generations from now what it is at present—a Garden District.

SCHOOL BUILT OF PLYWOOD



COMBINATION SCHOOL, AUDITORIUM AND GYMNASIUM, WHITE SALMON, WASHINGTON
Walter H. Rothe, Architect

THE type of construction utilizing plywood extensively, which may presage that which is to come, is the feature interest of a grade school combination gymnasium and auditorium recently completed at White Salmon, Wash. The structure, with a floor plan in the form of a cross composed of a large center unit and four ad-

BENICIA GRAMMAR SCHOOL

Bids have been taken by Harold H. Weeks, architect, 593 Market Street, San Francisco, for a five class room unit, auditorium and shop building for the Benicia Grammar School District, Solano County, California. Construction will be frame and stucco and the cost is estimated at \$70,000.

NEW CITY ARCHITECT

Dodge A. Reidy succeeds Charles H. Sawyer as City Architect for the City and County of San Francisco. Mr. Sawyer retired December 1 after long and efficient service. Mr. Reidy has had many years experience in the practice of his profession and his appointment has been favorably received by fellow practitioners and the public in general.

joining wings, has a framework composed of glued-up stress-covered rigid bent trusses enclosed with sidewall and roof prefabricated sectional panel units. The trusses and all panel units are almost entirely of Douglas fir plywood, in fact 85 per cent of the material required for the building is plywood. The Speedwall Co., Seattle, Wash., prefabricators of plywood buildings, inspired the design and engineered and acted as general contractor for the building. Walter H. Rothe, Yakima, Wash., was the architect. The construction principles are somewhat similar to those used on structures by the Forest Products Laboratory, Madison, Wis.

The building was originally designed to be built with conventional frame construction using 2x6-inch studs with shiplap sheathing and conventional siding. The roof was to be carried by light "A" trusses, and the interior was to be sealed with common matched boards, while the roof was to be composition over sheathing, and 1/2 fibre board insulation. However, when plans and specifications were submitted for bids, it was found that available funds were insufficient. At this juncture the Speedwall Company submitted preliminary designs of a structure of equal capacity but of better cubic utilization, and a more rational definition of the uses to which it was to be put, but yet at a price within the

budget of the school authorities. Final plans and specifications were subsequently approved, and ninety-day completion date set.

The framework of the structure is composed of twelve sets of rigid bent arches of 43-foot span and two sets of arches of 61-foot span resting on concrete footings. Head clearance in the gym is 20 feet at apex of center dome, and the ridge of its roof is carried level on each of the wings. Steel tierods under the floor bind arches at the footings to overcome outward thrust. Three sets of arches are used on each of four wings that adjoin the 43-foot central square, and two sets of arches support the central cell. The legs of all arches are 20 feet in length and are identical in construction and dimension. Only the arms of the two sets for the central dome are extended to provide greater span. Fabrication and erection of trusses were simplified through duplication. Fixed roof tree plates, purlins, or structural ties, were omitted from the frame, only temporary ties being used, as this permanent function is performed by the closure panel units.

The objective of the designers of the structure was, in addition to the more practical motives, a rational consideration of a project that obviously called for emphasis on functionalism. Economy was a prerequisite, and yet it may be considered that the finished job lacks little from the standpoint of permanency or good taste. The structure was so designed that, if wanted, a natural division of the floor area may be made for separate group play or instruction. As a gymnasium it has ample size for regulation play—both floor area and head clearance. All points on the floor are clearly visible from any seat in the seating section, with exception of the extreme corner seats, which lack a view of one basket. As an auditorium, it has adequate capacity and rostrum facilities for community gatherings. Although the capacity of the heating plant was reduced by one-third from the specifications given for the original conventionally designed building, it has been determined that the lowest outside temperature will not require capacity firing. The insulation efficiency of the side-walls and roof construction accounts for the remarkable economy of fuel and size of heating plant.

The structure, because of its Lauck self-bonding glued construction, is quite rigid. The few nails and bolts used were for the principal purpose of making contact while the self-bonding glue set. Therefore, basically, it is comparable in construction and tension to a stringed instrument. It is accordingly presumed that the rigidity and tension account for its remarkably efficient acoustics. No professional acoustical tests have been conducted in the building as yet, but it appears from lay demonstrations that phenomenal values approaching those of the Mormon Tabernacle and a few European structures, will be found. Voices of many pitches seem to carry without reverberation.



SHOWING TAPERED END OF STRESS-COVERED PLYWOOD, LAMINATED BENT BEFORE THE END WAS TRIMMED

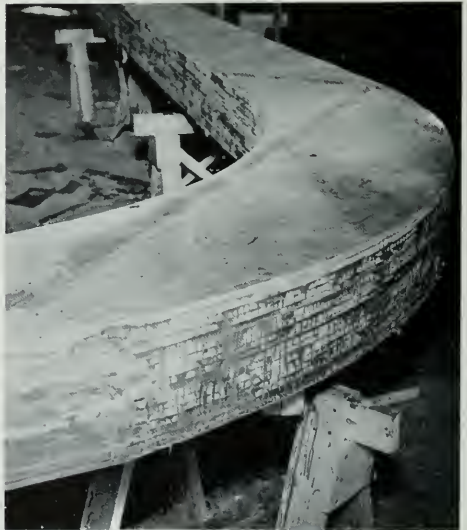

CLOSE UP OF THE PLYWOOD LAMINATED-BENT BEFORE THE STRESS COVERING WAS APPLIED



VIEW OF FRAMEWORK, COMBINATION AUDITORIUM AND GYMNASIUM,
WHITE SALMON, WASHINGTON

WALTER H. ROTHE, ARCHITECT

The frame work is composed of twelve sets of rigid bent arches of 43 ft. span and two sets of arches of 61 ft. span resting on concrete footings.



INTERIOR OF AUDITORIUM—NOTE USABLE CUBIC AREA WITH NO WASTE
SPACE TO HEAT AND LIGHT. ACOUSTICAL PROPERTIES IDEAL

CONSTRUCTION CONGRESS FAVORS NEW LEGISLATION

THE state-wide meeting of the California Construction Congress, held under the auspices of the State Chamber of Commerce in Fresno, November 16, was well attended and characterized by active interest and discussion of proposed or anticipated legislation affecting the industry, and by a general consensus of opinion. On these matters, as approved and recommended to the State Chamber for its support, there will now be a united and organized policy of action by the construction industry of the whole state.

The resolutions adopted were as follows:

1. Recommendation on Architectural Practice Act.
2. Recommendation regarding Civil Service.
3. Recommendation on Mechanics Lien Law.
4. Recommendation on Unemployment Reserves Act.
5. Recommendation on Contractors' License Law.
6. Resolution of California State Builders Exchange.

The resolutions in detail follow:

ARCHITECTURAL PRACTICE ACT

The proposed changes in Act, which were approved in principle, in general provide as follows:

For legal reasons, many of the former rules and regulations, such as the minimum requirements of education and training, and the examination subject matter, were incorporated in the new law.

The recording of certificates was abolished as unnecessary.

The collection of fees will now be handled by the Department of Professional and Vocational Standards, and the Board will be relieved of this duty. The question of delinquencies in the payment of fees has been covered and action will now be automatic through the State Department.

The general arrangement was made by the Code Commission and makes for simplicity and ease of index and exchange.

That the act as submitted be recommended by this Congress to the State Chamber of Commerce for support when presented to the State Legislature, provided that all interested groups under the Department of Professional and Vocational Standards are in accord upon the provision of the act.

Recommendation approved.

CIVIL SERVICE PROVISIONS

The changes proposed in the Civil Service Provisions of the State Constitution should be considered as clarifications, in no way jeopardizing the fundamental principles involved in the Civil Service Amendment.

It is hoped and believed that the State Civil Service Employees Association will aid in passing the necessary legislation.

Previous to passage of the Civil Service Amendment, State departments could, when desired, employ consultants on various state projects, or projects under state supervision, and also let out contracts when needed for the preparation of plans and specifications, and for the construction of State Buildings, Roads and Structures.

The Civil Service Amendment as interpreted by the courts now prohibits such acting by State departments, with a few minor exemptions.

The changes proposed would re-establish a permissive procedure in effect before the Civil Service Amendment was passed, and a procedure which it is believed the original sponsors of the Civil Service Amendment did not intend to throw out.

The clarifications proposed would be to the best interests of the various State Departments, and would be equitable to the Architectural, Engineering, Legal, and Contracting professions.

Recommendation approved.

MECHANICS LIEN LAW

Whereas, There is a large percentage of present new construction of residential projects of the one- and two-family class that is prosecuted by the so-called speculative or owner-builder operator, and

Whereas, Under the present provisions of the so-called Mechanics Lien Law, the lien period as to all parties performing labor or furnishing materials on such projects is 60 days (where proper notice of completion filed), while normally the speculative builder, were he a general contractor, the lien period would as to all parties, other than the general contractor, be 30 days, and

Whereas, The present provisions of the said Mechanics Lien Law creates a condition whereby many jobs which otherwise would reflect the true owner of the said projects appear in the names of the "dummy owner";

Now, Therefore, Be It Resolved: That this group go on record as approving an amendment to the proper sections of the Mechanics Lien Law to shorten the period in which Mechanics Lien may be filed on such projects to 30 days, where a proper notice of completion is filed in accordance with section 1187 Code of Civil Procedure, otherwise to remain as at present; provided that the building permit, where permits are required, and the notice of completion plainly and adequately discloses full information as to ownership and character of improvement; that the Mechanics Lien Law remain as at present in other respects.

Recommendation approved.

ARCHITECTS' BULLETIN

Issued For

THE STATE ASSOCIATION OF CALIFORNIA ARCHITECTS Northern Section

STATE ASSOCIATION MEMBER
OF THE
AMERICAN INSTITUTE OF ARCHITECTS
Editor

Harris C. Allen

Address all communications for publication in the Bulletin to the Editor (Harris C. Allen) 557 Market Street, Room 218, San Francisco, California.

Board of Control

Harris C. Allen Otto G. Hintermann
Harry Michelsen Wayne S. Hertzka

State Association Officers

President Sylvanus B. Marston, Pasadena
Vice-President Gwynn Officer, Berkeley
Secretary Wayne S. Hertzka, San Francisco
Treasurer Robert H. Orr, Los Angeles

Regional Director, A. I. A.

Albert J. Evers, San Francisco
Deputy Regional Director, Southern
California
Gordon B. Kaufmann, Los Angeles

Executive Board—Northern Section

Officers

President Gwynn Officer, Berkeley
Vice-Pres. Ernest E. Weihe, San Francisco
Secretary Wayne S. Hertzka, San Francisco
Treasurer Otto G. Hintermann, San Francisco

Directors

Harry J. Devine R. H. Reimers
Harry J. Merchant Harold Weeks

Executive Board—Southern Section

Officers

President Sylvanus B. Marston
Vice-President Louis N. Crawford
Secretary Winsor Soule
Treasurer Robert H. Orr

Directors

Merrill W. Baird Abe Edelman
Harold C. Chambers George D. Riddle

Advisors—Northern Section

Harris C. Allen San Francisco
J. K. Ballantine, Jr. (Secretary)
Sam. Lightner Hymen
Wm. G. Merchant
Jas. F. McGuiness
Dodge A. Riedy
Harold H. Weeks
Ernest E. Weihe
Albert R. Williams
Fred. H. Reimers (President)
C. A. Caulkins North Bay District
Peter Sala Lower San Joaquin
District
J. U. Cloudsley (Secretary)
Edw. W. Kress Santa Clara Valley
Mario Corbett San Mateo
Alden Cambell Sacramento
Ernest J. Kump Upper San Joaquin
Dole F. Thomsen Palo Alto
Norman W. Sexton Marin
Geo. P. Simonds East Bay
Chester Treichel East Bay
Gwynn Officer Berkeley
F. T. Georgeson Redwood Empire
Casebolt Dakin Upper Sacramento
Ralph Taylor Lassen District

DRAFTSMEN'S HOURS

The Executive Board of the State Association of California Architects, Northern Section, has approved, for recommendation to all members, the following resolution by the California Society of Architectural Draftsmen:

WHEREAS, the California Society of Architectural Draftsmen was formed to foster closer relationship between architects and architectural draftsmen; to advance the profession of Architecture through unity; to co-operate with the State Association of California Architects in encouraging and promoting architectural education; and,

WHEREAS, the California Society of Architectural Draftsmen, Northern Section, believes that a uniformity of conditions within the Architectural profession is a primary step toward a stronger unity of the whole; therefore, be it RESOLVED, that the following working hours be recommended to the membership by the Executive Board of the State Association of California Architects, Northern Section.

1. The maximum number of working hours per week shall be forty hours.
2. All working hours over and above forty hours per week are to be defined as overtime and paid at the rate of time and one-half.
3. A week shall consist of five eight hour days with Saturdays and Sundays to be non-working days.
4. Legal holidays shall be: New Years day, Washington's Birthday, Independence Day, Memorial Day, Labor Day, Thanksgiving and Christmas.

RESOLUTION PERTAINING TO EMPLOYMENT

WHEREAS, the California Society of Architectural Draftsmen, Northern Section, is establishing a complete membership employment system giving full information as to the qualification of every member; and,

WHEREAS, this file will be maintained at the office of the State Association of California Architects, Northern Section, 557 Market Street, telephone DOuglas 4561; therefore, be it further

RESOLVED that the Northern Section of the State Association of California Architects be urged to give this file first consideration in employing draftsmen.

CO-OPERATION

It is a pleasure to be able to repeat the recognition now given annually to The Architect & Engineer and Architects Reports by the State Association, for constructive co-operation to further the best interests of profession and industry.

WHEREAS: The State Association of California Architects recognizes the strides made by "The Architect and Engineer" in the interests of architecture on the Pacific Coast, and

WHEREAS: The Association desires to renew its faith in this publication and make expression of the good will existing between itself and "The Architect and Engineer."

THEREFORE BE IT RESOLVED: That the Association in the Eleventh Annual Convention assembled in San Francisco October 13, 14 and 15th gives its full support to the endorsement of "The Architect and Engineer" and "Architects Reports" and goes on record as being in complete sympathy with the editorial aim of this publication.

UNIFICATION

The progress of national unification continues in its gradual process of comment and criticism and suggestion. From the Institute Committee comes a report by Arthur B. Holmes, chairman, which presents both the ideals and the difficulties, as well as the underlying spirit of determination to find the satisfactory solution in the long run.

At this time many impecunious but highly desirable architects are shading the established ethics of the Institute. This condition has been clearly apparent in New Jersey, as it must be in every other state. And, because we realize that a man's first duty is the support of his family, we have been rather lenient, many times closing one eye when we have found conditions which, been constituted in the past, the Institute was not set up to handle these problems. In order that the scope of the Institute may be increased to make it the actual dominant factor in the control of the profession we need these same state organizations fully as much as they need us. They represent the natural medium for handling these important state problems.

In New Jersey we have an excellent registration law, examinations of applicants for license are strict but fair and highly professional. Our practice law is, I believe, as good as any other in the other forty-seven states, protecting architect and public alike. Our state Board of Architects, dominating these issues, is appointed by the Governor from nominations made by the N. J. Society of Architects and this is written into the law. All of these conditions are directly traceable to the efforts of our State Association. One has only to step on the toes of the profession in the State House and it is surprising how quickly the architects of the state rally around at the first sign of danger.

A second reason why the Institute has not more effectively increased its membership is because architects practice too far from the headquarters of the nearest Chapter. But the State Associations can function through local branches embracing a municipality, a county or several counties, thereby bringing organization to the individual. For this reason also we need them in the Institute.

I feel that the great majority would join the Institute this year if they felt that the membership would repay them for the outlay. We must recognize the inherent selfishness of the individual. We must sell them organization, but first we must have a definite offering to sell

which will appeal to them. You and I are convinced of the value of the Institute, but try to sell generalities to a canny prospect who must watch his pennies. We are very apt to run into a cul-de-sac and must retreat with as little loss of face as possible when they inquire what the Institute is doing for them. Ethics, ideals, principle, education, yes,—but their first problem is trying to earn a living. In dollars and cents, what is the Institute doing for them? It is a brutal question, but it is one the Committee on State Organization must answer if we are to get anywhere with unification.

We recognize that we have a tough problem ahead of us. Possibly it cannot be solved, but we are not ready to admit it,—yet. I look forward to several years of effort before we can arrive at a satisfactory basis from which to attack the problem. Developing this basis we must do as much educative work within the Institute as without. And before we are in a position to educate we must, ourselves, learn the problem thoroughly, study all the angles and possible solutions. At this time I admit no necessity for any lowering of standards, but I feel definitely we must improve our product to develop a sales appeal which seems to be lacking at present. This is no criticism of the Institute, which, to me, represents the best and finest in the profession, but it is an expression of belief that we must put it on a 1938 chassis before we can make it run efficiently for another period of years.

FOR CONCRETE INDUSTRIES MEETING

The Third Annual Concrete Industries Convention and Exposition will be held at the Sherman Hotel, Chicago, February 7, 8 and 9, 1939. Already many new exhibitors have reserved space, assuring a greater diversity of construction equipment to amplify the comprehensive exhibits of previous years.

The program of the American Concrete Contractors Association will include demonstrations of new methods of handling concrete work to improve quality and cut costs. Special attention will be given to the various fields that appear most promising for 1939, and what can be done to participate in these profitable opportunities.

Recognizing the growing popularity of the concrete house, the program of the National Concrete Masonry Association will present in considerable detail the various means that have been used successfully by concrete products manufacturers to win markets to this type of construction.

OAKLAND STORE BUILDING

A one story reinforced concrete and brick store building is to be built at 23rd Street and San Pablo Avenue, Oakland, from plans by Earl R. MacDonald, 1710 Franklin Street, Oakland. The estimated cost is \$12,000.

With the Architects

SUMNER P. HUNT, ARCHITECT

Sumner P. Hunt, practicing architect in Los Angeles for nearly a half century, died at his home, 2647 Severance Street, Los Angeles, November 19, after two days' illness. Mr. Hunt was 73.

Coming to Los Angeles in 1889, Mr. Hunt embarked in a professional career in which he achieved notable success. His first important work was the Bradbury Building, at Third and Broadway, which was designed as a monument to the owner, and which is today one of the most interesting of the many downtown office buildings by reason of its central covered light court encircled by open corridors connecting the offices.

In 1908 Mr. Hunt formed a partnership with Silas R. Burns which was terminated only a few years ago by the retirement of the latter.

Designing of many important buildings in Los Angeles is credited to Mr. Hunt individually or to his firm. Among them are the Los Angeles Country Club, Ebell Club, Friday Morning Club, Automobile Club of Southern California, Southwest Museum and a number of schools, including David Starr Jordan High School, Louis Pasteur Junior High School and the Virgil Avenue Junior High School.

Mr. Hunt was a member of the Allied Architects Association, which designed the Hall of Justice and the Los Angeles County General Hospital. He served as member of the Los Angeles City Planning Commission and the Municipal Art Commission.

Mr. Hunt was a member of the American Institute of Architects and past president of Southern California Chapter.

NEUTRA IN THEATER COMPETITION

Richard Neutra of Los Angeles is one of the five architects selected to compete on a design for a great festival theater to be built on the campus of William and Mary College, Williamsburg, Va., by the American National Theater and Academy. The other architects are Goodwin & Stone of New York; Walter Gropius, Cambridge, Mass.; Michael Hare, New York, and Harrison & Fouilhoux, New York. Designs are to be submitted by January 31, 1939, and the selection will be announced the following month. Erection of similar theaters are contemplated in the southwest, middle west and on the Pacific Coast.

BAYWOOD SCHOOL ADDITION

The San Mateo Grammar School District has received bids for an addition to the Baywood School, consisting of five class rooms and library. W. H. Toepke and Edwards & Schary are the architects. The estimated cost of the improvements is \$70,000.

CLARK TO SUCCEED KELLY

Earl Lee Kelly, California state director of public works, has tendered his resignation to Governor Merriam, effective December 31. Mr. Kelly served under both the Rolph and Merriam administrations.

Governor-elect Olson has announced the appointment of Frank W. Clark, Los Angeles construction executive and irrigation expert, to succeed Mr. Kelly, effective January 1. Mr. Clark was founder and president of the Sunset Rock Products Corporation; later became executive vice-president and general manager of the Consolidated Rock Products Corporation, and in 1933 became president of the Ruth Dredger Manufacturing Corporation.

PERSONALS

J. C. Park, professor of Civil Engineering at the University of Arizona, has been elected president of the Arizona Section, American Society of Civil Engineers for 1939.

Paul Gordon Carlson, Seattle architect who recently was issued a professional license by the Washington State Board of Architect Examiners, has been for several years head designer in the office of Architect Bjarne H. Moe, 2318 Second Avenue, Seattle.

George Stewart, Seattle architect and member of the firm of Baker, Stewart & Palmaw, 406 Railway Exchange Building, recently was appointed associate architect for Bonneville Administration. He is stationed at the project headquarters office in Portland, Oregon.

Eric C. Rising, former Seattle architect who has been a resident engineer inspector with the PWA for the past four years, has been promoted to traveling engineer for the entire state of Montana.

William Mallis, school architect of Seattle, delivered an address on "The Architect's Viewpoint" at the formal dedication ceremony of the new elementary school building at Kent, Wash., October 27.

WASHINGTON STATE ARCHITECTS' SOCIETY

Harry G. Hammond, Arthur B. Cornelius and Harry E. Nordquist, nominating committee of the Washington State Society of Architects, submitted their report for society officers at the annual meeting December 8. The society's representative on the Central Housing Information Bureau, will be Mr. Hammond. To aid Roy Misener, King County assessor, in his property revaluation program, President Taylor has appointed Walter Jackson, who has been active in designing industrial buildings.

MASTEN AND HURD BUSY

One of the busiest architectural firms in the San Francisco Bay region are Masten and Hurd, 442 Post Street, San Francisco. Schools, commercial buildings and residences are keeping the office on the qui vive day and night. Plans are being rushed for the new printing building for the University of California which is to occupy the site of the present Leder, Street & Zeus plant at Oxford and Center Streets, Berkeley, which firm will shortly move to its new home on Allston Way from plans by the same architects. Masten and Hurd have also completed plans for a group of High School buildings at Alturas, Modoc County, California, estimated to cost \$170,000.

S. F. JUNIOR COLLEGE

The first unit, consisting of science buildings, in a \$1,000,000 school building program for the San Francisco Junior College, will be started shortly from plans by Messrs. Miller and Pflueger, 580 Market Street, San Francisco. The structures will occupy a portion of a 28 acre tract at Ocean and Phelan Avenues. Leland and Haley are the mechanical engineers and Walter L. Huber the structural engineer.

SANTA ROSA COLLEGE

C. A. Calkins, Rosenberg Building, Santa Rosa, has completed plans for a group of Junior College buildings to be erected at Santa Rosa at a cost of \$300,000. A PWA grant and bonds have been approved and bids will be advertised shortly. Besides an administration unit there will be a large assembly hall and library. Construction will be steel, concrete, brick veneer and tile roof.

S. F. CONTRACTORS BUSY

Two thirds of the work now being figured or under way by San Francisco contractors is centered at the Golden Gate International Exposition. The Island is said to be a veritable bee-hive of activity. Only one month remains to complete construction work and contractors are taking advantage of the good weather by working all the help available.

MENLO PARK RESIDENCE

John E. Dinwiddie, 360 Pine Street, San Francisco, has completed plans for a \$10,000 two story frame residence at Menlo Park for Harold Smith of the Dinwiddie Construction Company, Crocker Building, San Francisco.

JUNIOR COLLEGE BUILDINGS

Harry J. Devine of Sacramento has completed working drawings for a group of Junior College buildings at Sacramento to cost \$190,000.

POST-WAR ARCHITECTURE

A traveling exhibition representative of post-war architecture will be shown in leading cities on the

Pacific Coast next year, the exact dates to be announced.

The exhibition had its genesis in the desire to present to the public, to the architects themselves, and to schools, a general, well-rounded survey, in excellent photographs and plans, of buildings which architects consider "fine" in design, and "representative" of the best work executed in the United States since the world war.

For practically two years, the special exhibits committee and the committee on education of The American Institute of Architects have been busy selecting and assembling material, and the American Federation of Arts with preparation and plans for circulation.

To assure a comprehensive range of buildings, 1500 letters were mailed by the committee on education, A. I. A., to directors and officials of the A. I. A., to Chapters, to staffs of architectural schools, and to practicing architects throughout the country.

These groups submitted more than 1000 buildings as being worthy of consideration. With photographs of each building available, the committee assumed the task of elimination. From these 1000, a pre-selection of 250 was made; final selection brought the exhibition down to its limit of 150 buildings. The selection was as impartial as possible, the intent being to choose "representative" buildings, irrespective of school, style or individual.

Owing to the size of the exhibition, it was deemed advisable to divide it into two sections, the choice of section being left to the exhibiting agency. However, both sections may be combined where facilities are available.

The first section, of seventy mounts—of which all but ten are 30 x 48 inches—with as many as six photographs to a mount, shows residences and housing projects; town planning, hotels, apartments, educational and recreational buildings and hospitals.

The second section, comprising 80 mounts, with all but 20 of the large size, is devoted to government, municipal and commercial industrial structures, libraries, museums and churches.

It is possible that a duplicate of the entire collection, originally prepared for circulation in Europe, may travel in America for a year first.

The exhibition is national in character. Buildings in 29 states and the District of Columbia—from 72 cities and towns, show the variety of architectural styles in the United States.

Aside from the public interest, one of the primary purposes of the exhibition is educational, and many universities and schools are on the circuit.

Organizations or communities interested in presenting the exhibition should communicate with the American Federation of Arts, Barr Building, Washington, D.C.

Estimator's Guide

Giving Cost of Building Materials, Wage Scale, Etc.

Amounts given are figuring prices and are made up from average quotations furnished by material houses to San Francisco contractors. 3% Sales Tax on all materials but not labor.

All prices and wages quoted are for San Francisco and the Bay District. There may be slight fluctuation of prices in the interior and southern part of the state. Freight cartage, at least, must be added in figuring country work.

3rd—1 1/2% amount of contract.

Brickwork—

Common, \$40 to \$45 per 1000 laid, (according to class of work).

Face, \$100 to \$110 per 1000 laid, (according to class of work).

Brick Steps, using pressed brick, \$1.25 lin. ft.

Brick Veneer on frame buildings, \$.75 sq. ft.

Common f.o.b. cars, \$14.00 at yard. Cartage extra.

Face, f.o.b. cars, \$45.00 to \$50.00 per 1000 carload lots.

HOLLOW TILE FIREPROOFING (f.o.b. job)

3x12x12 in. \$ 84.00 per M

4x12x12 in. 94.50 per M

6x12x12 in. 126.00 per M

8x12x12 in. 225.00 per M

HOLLOW BUILDING TILE (f.o.b. job)

carload lots.

8x12x5 1/2 \$ 94.50

6x12x5 1/2 73.50

Building Paper—

1 ply per 1000 ft. roll \$3.50

2 ply per 1000 ft. roll 5.00

3 ply per 1000 ft. roll 6.25

Brownskin, 500 ft. roll 4.50

Brownskin, Pro-foctomat, 1000 ft. roll 9.00

Sisalraft, 500 ft. roll 5.00

Sash cord com. No. 7 \$1.20 per 100 ft

Sash cord com. No. 8 1.50 per 100 ft

Sash cord spot No. 7 1.90 per 100 ft

Sash cord spot No. 8 2.25 per 100 ft

Sash weights cast iron, \$50.00 ton.

Nails, \$3.50 base.

Sash weights, .95 per ton.

Concrete Aggregates—

Gravel (all sizes) \$1.45 per ton at bunker; delivered to any point in S. F. County \$1.85.

	Bunker	Delivered
Top sand	\$1.45	\$1.85
Concrete mix	1.45	1.85
Crushed rock, 1/4 to 3/4	1.60	2.00
Crushed rock, 3/4 to 1 1/2	1.60	2.00
Roofing gravel	1.60	2.00
City gravel	1.45	1.85
River sand	1.40	1.80

Delivered bank sand—\$1.00 per cubic yard at bunker or delivered.

SAND—

	Bunker	Delivered
River sand	\$1.40	\$1.80
Lapis (Nos. 2 & 4)	2.00	2.40
Olympia Nos. 1 & 2	1.80	2.20
Headburr plaster sand	1.80	\$2.20
Del Monte white	1.80	50 per sack

CEMENT (all brands, cloth sacks) \$2.72 per bbl. f.o.b. cars; deliv. \$2.90 per bbl.; carload lots; less than carload lots, warehouse or delivered, 80c per sack. (Less 10c per sack returned, 2% 10th Prox.)

Common cement (all brands, paper sacks) carload lots \$2.52 per bbl. f.o.b. car; delivered, \$2.70; less than carloads delivered, 75c per sack. Discount on cloth sacks, 10c per sack. Cash discount on carload lots, 10c a barrel 10th Prox.; cash discount less than carload lots, 2%.

Atlas White } 1 to 100 sacks, \$1.50 sack,
Galaveras White } warehouse or delivery; over 100
Medusa White } sacks, \$1.25; 2% discount 10th of month.

Forms, Labors average \$40.00 per M. Average cost of concrete in place, exclusive of forms, 35c per cu. ft.; with forms, 60c. 4-inch concrete basement floor 12 1/2c to 14c per sq. ft. Ret-proofing 7 1/2c Concrete Steps \$1.25 per lin. ft.

Dampproofing and Waterproofing—

Two-coat work, 20c per yard. Membrane waterproofing—4 layers of saturated felt, \$4.50 per square. Hot coating work, \$1.80 per square. Medusa Waterproofing, 15c per lb., San Francisco Warehouse. Tricoceal waterproofing. (See representative.)

Electric Wiring—\$12.00 to \$15.00 per outlet for conduit work (including switches). Knob and tube average \$3.50 per outlet.

Elevators—

Prices vary according to capacity, speed and type. Consult elevator companies. Average cost of installing an automatic elevator in four-story building, \$2800; direct automatic, about \$2700.

Excavation—

Sand, 60 cents; clay or shale \$1 per yard. Teams, \$12.00 per day. Trucks, \$22 to \$27.50 per day. Above figures are an average without water. Steam shovel work in large quantities, less; hard material, such as rock, will run considerably more.

Fire Escapes—

Ten-foot galvanized iron balcony, with stairs, \$115 installed on new buildings; \$140 on old buildings.

Floors—

Composition Floors—22c to 40c per sq. ft. In large quantities, 16c per sq. ft. laid. Mosaic Floors—80c per sq. ft. Duraflex Floor—23c to 30c sq. ft. Rubber Tile—50c to 75c per sq. ft. Terazzo Floors—45c to 60c per sq. ft. Terazzo Steps—\$1.60 lin. ft.

Hardwood Flooring (delivered to building)— 1 1/2x2 1/4" T & G Maple \$ 88.00 M ft. 1 1/2x2 1/4" T & G Maple 115.00 M ft. 7/8x3 1/2" sq. edge Maple 100.00 M ft.

	1 1/2x2 1/4" T&G	3/4x2" T&G	3/4x2" sq. Ed.
Clr. Qrd. Oak	\$120.00 M	\$ 82.50 M	\$110 M
Sel. Qrd. Oak	99.00 M	69.50 M	84 M
Clr. Pla. Oak	106.00 M	74.50 M	86 M
Sel. Pla. Oak	97.00 M	62.50 M	76 M
Clear Maple	111.00 M	100.00 M	
Laying & Finishing	14c ft.	12c ft.	10c ft.

Note—Above quotations are all board measure except last column which is sq. ft.

Glass (consult with manufacturers)— Double strength window glass, 20c per square foot. Plate 75c per square foot (unglazed) in place, \$1.00.

Art, \$1.00 up per square foot. Wire (for skylights), 40c per sq. foot. Obscure glass, 30c square foot. Glass bricks, \$2.40 per sq. ft., in place. Note—If not stipulated add extra for setting.

Heating—

Average, \$1.90 per sq. ft. of radiation, according to conditions. Warm air (gravity) average \$40 per register. Forced air, average \$60 per register.

Iron—Cost of ornamental iron, cast iron, etc., depends on designs.

Lumber (prices delivered to bldg. site). No. 1 common \$29.00 per M No. 2 common 27.00 per M Select O. P. common 34.00 per M 2x4 No. 3 form lumber 24.00 per M 1x4 No. 2 flooring VG 55.00 per M 1x4 No. 3 flooring VG 47.00 per M 1x6 No. 2 flooring VG 60.00 per M 1x4x4 and 6, No. 2 flooring 60.00 per M

Slash grain— 1x4 No. 2 flooring \$43.00 per M 1x4 No. 3 flooring 40.00 per M No. 1 common run T & G 30.00 per M Lath 5.25 per M

Shingles (add cartage to price quoted)— Redwood, No. 1 \$1.10 per bble. Redwood, No. 290 per bble. Red Cedar 1.10 per bble.

Plywood—Douglas Fir (ad cartage)— "Plycord" sheathing (unsanded) 5/16" 3-ply and 48"x96" \$30.00 per M Wallboard Grade (sound one side)— 1/2" 3-ply 48" x 96" \$37.50 per M Concrete Form Panels (special core & glue) 5/8" 5-ply 48" x 96" \$10.00 per M If tiled \$5.00 extra per M

Millwork—Standard.

O. P. \$85.00 per 1000, R. W., \$90.00 per 1000 (delivered). Double hung box window frames, average with trim, \$6.50 and up, each. Doors, including trim (single panel, 1 3/4 in. Oregon pine) \$8.00 and up, each. Doors, including trim (five panel, 1 3/8 in. Oregon pine) \$6.00 each. Screen doors, \$3.50 each. Patent screen windows, 25c a sq. ft. Cases for kitchen cabinets seven ft. high per lineal ft., \$8.00 each. Dining room cases, \$8.00 per lineal foot. Rough and finish about 75c per sq. ft.

Labor—Rough carpentry, warehouse heavy framing (average), \$17.50 per M. For smaller work average, \$35.00 to \$45.00 per 1000.

Marble—(See Dealers)

Painting—

Two-coat work	36c per yard
Three-coat work	50c per yard
Cold Water Painting	10c per yard
Whitewashing	4c per yard
Turpentine, 65c per gal., in 5 gal. cans, and 55c per gal. in drums.	
Raw Linseed Oil—97c gal. in bbls.	
Boiled Linseed Oil—\$1.00 gal. in bbls.	
Medusa Portland Cement Paint, 20c per lb.	

Pioneer or Dutch Boy White Lead in Oil (in steel kegs).

	Per Lb.
1 ton lots, 100 lbs. net weight.....	10/4c
500 lbs. and less than 1 ton lots.....	10/2c
Less than 500 lb. lots.....	11c

Pioneer or Dutch Boy Red Lead and Litharge (in steel kegs).

1 ton lots, 100 lb. kegs, net weight.....	10/4c
500 lbs. and less than 1 ton lots.....	10/2c
Less than 500 lb. lots.....	11c

Pioneer Red Lead in Oil (in steel kegs)

1 ton lots, 100 lb. kegs, net weight.....	11/4c
500 lbs. and less than 1 ton lots.....	11/2c
Less than 500 lb. lots.....	12c

Note—Accessibility and conditions cause some variance in costs.

Patent Chimneys—

6-inch	\$1.25 lineal foot
8-inch	1.75 lineal foot
10-inch	2.25 lineal foot
12-inch	3.00 lineal foot

Plastering—Interior—

	Yard
1 coat, brown mortar only, wood lath.....	\$0.75
2 coats, lime mortar hard finish, wood lath ..	.80
2 coats, hard wall plaster, wood lath.....	.85
3 coats, metal lath and plaster.....	1.50
Keene cement on metal lath.....	1.60
Ceilings with 3/4 hot roll channels metal lath	.90

Ceilings with 3/4 hot roll channels metal lath plastered.....	1.65
Single partition 3/4 channel lath 1 side.....	.85
Single partition 3/4 channel lath 2 sides 2 inches thick	1.50
4-inch double partition 3/4 channel lath 2 sides	1.30
4-inch double partition 3/4 channel lath 2 sides plastered	3.00

Plastering—Exterior—

2 coats cement finish, brick or concrete wall	\$1.00
2 coats Colaveras cement, brick or concrete wall	1.35
3 coats cement finish, No. 18 gauge wire mesh	1.50
3 coats Colaveras white finish, No. 18 gauge wire mesh	1.75

Wood lath, \$7.50 to \$8.00 per 1000.....	
2.5-lb. metal lath (dipped).....	.17
2.5-lb. metal lath (galvanized).....	.20
3.4-lb. metal lath (dipped).....	.22
3.4-lb. metal lath (galvanized).....	.28
3/4-inch hot roll channels, \$72 per ton.....	
Finish plaster, \$18.90 ton; in paper sacks.	
Dealer's commission, \$1.00 off above quotations.	
\$13.85 (rebate 10c sack).	
Lime, f.o.b., warehouse, \$2.25 bbl.; cars, \$2.15 Lime, bulk (ton 2000 lbs.), \$16.00 ton.	
Wall Board 5 ply, \$8.00 per M.	
Hydrate Lime, \$19.50 ton.	
Plasterers Wage Scale	1.25 per hour
Lathers Wage Scale	1.25 per hour
Ho'd Carriers Wage Scale	1.10 per hour

Composition Stucco—\$1.80 to \$2.00 sq. yard (applied).

Plumbing—

From \$70.00 per fixture up, according to grade, quantity and runs.

Roofing—

"Standard" tar and gravel, \$6.50 per sq. for 30 sqs. or over.	
Less than 30 sqs, \$7.00 per sq.	
Tile, \$20.00 to \$35.00 per square.	
Redwood Shingles, \$7.50 per square in place.	
Copper, \$16.50 to \$18.00 per sq. in place.	
Cedar Shingles, \$8.00 per sq. in place.	
Recosat, with Gravel, \$3.00 per sq.	
Asbestos Shingles, \$15 to \$25 per sq. laid.	

Slate, from \$25.00 to \$60.00 per sq. yard, according to color and thickness.	
Shakes—1 1/2" x 25" rasawn	\$11.50 per sq.
1/2" x 25" resawn	10.50 per sq.
1/2" x 25" tapered	10.00 per sq.

Above prices are for shakes in place.

Sheet Metal—

Windows—Metal, \$1.75 a sq. foot.
Fire doors (average), including hardware, \$1.75 per sq. ft.

Skylights—(not glazed)

Copper, 90c sq. ft. (flat).
Galvanized iron, 30c sq. ft. (flat).
Vented hip skylights 60c sq. ft.

Steel—Structural

\$120 ton (erected), this quotation is an average for comparatively small quantities. Light truss work higher. Plain beams and column work in large quantities \$90 to \$100 per ton.

Steel Reinforcing—

\$80.00 to \$120.00 per ton, set.

Stone—

Granite, average, \$6.50 cu. foot in place
Sandstone, average Blue, \$4.00, Boise \$3.00 sq. ft. in place.

Indiana Limestone, \$2.80 per sq. ft. in place.

Store Fronts—

Copper sash bars for store fronts, corner center and around sides, will average 75c per lineal foot.

Tile—Floor, Wainscot, etc.— (See Dealers)

Asphalt Tile—18c to 28c per sq. ft. installed.

Wall Tile

Glazed Terra Cotta Wall Units (single faced) laid in place—approximate prices:	
2 x 6 x 12	\$1.00 sq. ft.
4 x 6 x 12	1.15 sq. ft.
2 x 8 x 16	1.10 sq. ft.
4 x 8 x 16	1.30 sq. ft.

Venetian Blinds—

40c per square foot end up. Installation extra.

THE BUILDERS' EXCHANGE OF SAN FRANCISCO STANDARD WAGE SCALE

For mechanics employed on construction work in the Bay Region. Effective September 1, 1937

CRAFT	Journeymen Mechanics
Asbestos Workers	\$ 8.00
Bricklayers (8h-5d)	8.50
Bricklayers' Hodcarriers (8h-5d)	8.75
Cabinet Workers (Outside) (5d)	8.00
Caisson Workers (Open)	6.40
Carpenters (8h-5d)	10.00
Cement Finishers (8h-5d)	10.00
Cork Insulation Workers (8h-5d)	9.00
Electric Workers (8h-5d)	11.00
Electrical Fixture Hangers	8.00
Elevator Constructors	10.40
Engineers, Portable & Hoisting	9.00
Glass Workers (8h-5d)	9.68
Hardwood Floormen	9.00
Housesmiths, Architectural Iron (Shop) (8h-5d)	9.00
Housesmiths, Architectural Iron (Outside) (8h-5d)	10.00
Housesmiths, Reinforced Concrete or Rodmen (8h-5d)	10.00
Iron Workers (Bridge and Structural) Including Engineers (8h-5d)	12.00

CRAFT	Journeymen Mechanics
Laborers, Building (8h-5d)	\$ 6.00
Laborers, Common (8h-5d)	6.00
Lathers, Channel Iron (8h-5d)	9.00
Lathers, All Others	9.00
Marble Setters (8h-5d)	10.50
Marble Setters' Helpers (8h-5d)	9.50
Millwrights	9.00
Model Makers (\$1.50 per hr-6h)	9.00
Modelers (\$2 per hr-6h)	12.00
Model Casters	7.20
Mosaic and Terrazzo Workers (Outside)	9.00
Painters (7h-5d)	8.50
Painters, Varnishers and Polishers (Outside)	9.00
File Drivers and Wharf Builders	9.00
Plasterers' Engineers	10.00
Plasterers (8h-5d)	10.00
Plasterers' Hodcarriers (8h-5d)	7.50
Plumbers (8h-5d)	11.00
Roofers, Composition (8h-5d)	9.00
Roofers, All Others (8h-5d)	8.00
Sheet Metal Workers (8h-5d)	10.00
Sprinkler Fitters	10.00

CRAFT	Journeymen Mechanics
Steam Fitters (8h-5d)	\$11.00
Stein Builders (8h-5d)	9.00
Stone Cutters, Soft and Granite (8h-5d)	8.00
Stone Setters, Soft and Granite	12.00
Stone Derricks	9.00
Tile Setters (8h-5d)	11.00
Tile Setters' Helpers (8h-5d)	6.50
Tile, Cork and Rubber (8h-5d)	9.00
Welders, Structural Steel Frame on Buildings 11.00	
Welders, All Others on Buildings	9.00
Dump Truck Drivers, 2 yards or less	6.00
Dump Truck Drivers, 3 yards	6.50
Dump Truck Drivers, 4 yards	7.00
Dump Truck Drivers, 5 yards	7.00
Dump Truck Drivers, 6 yards	7.50
Truck Drivers of Concrete Mixer Trucks:	
2 yards or less	6.50
3 yards	7.00
4 yards	7.50
5 yards	7.50
6 yards	8.00

GENERAL WORKING CONDITIONS

- Eight hours shall constitute a day's work for all crafts except as otherwise noted.
- Plasterers' Hodcarriers, Bricklayers' Hodcarriers, Roofers, Laborers, and Engineers, Portable and Hoisting, shall start 15 minutes before other workmen, both at morning and at noon.
- Five days, consisting of not more than eight hours a day, on Monday to Friday inclusive, shall constitute a week's work.
- Transportation costs in excess of twenty-five cents each way shall be paid by the contractor.
- Overtime shall be paid as follows: For the first four hours after the first eight hours, time and one-half. All time thereafter shall be paid

- double time. Saturdays (except Laborers), Sundays and holidays, from 12 midnight of the preceding day, shall be paid double time.
- On Saturday, Laborers shall be paid straight time for an eight-hour day.
- Where two shifts are worked in any twenty-four hours, shift time shall be straight time. Where three shifts are worked, eight hour's pay shall be paid for seven hours on the second and third shifts, allowing one-half hour for lunch.
- All work, except as noted in paragraph 9, shall be performed between the hours of 8 a.m. and 5 p.m.
- In emergencies, or where premises cannot be vacated until the close of business, men then

- reporting for work shall work at straight time. Any work performed on such jobs after midnight shall be paid time and one-half up to four hours of overtime and double time thereafter, provided, that if a new crew is employed on Saturdays, Sundays or holidays which has not worked during the five preceding days, such crew shall be paid time and one-half.
- Recognized holidays to be: New Year's Day, Decoration Day, Fourth of July, Labor Day, Admission Day, Thanksgiving Day, Christmas Day.
- Men ordered to report for work, for whom no employment is provided, shall be entitled to two hours' pay.

MODERNIZED PRODUCTS

Brief Notes on New Materials and Equipment in the Building Industry.

137. OIL BURNERS

The H. C. Little Company have issued two small booklets, one describing an automatic oil-burning heating unit for larger homes and the other a complete heating unit for the smaller home, also oil-burning and automatic. Send for your copy by clipping the coupon.

138. PLYWOOD

New folders illustrating the products and especially "Resnrest," a plywood made by the M and M Woodworking Company, are announced. These folders contain all the pertinent data of interest to contractors and home builders and also information for builders of small boats, forms and signs.

139. HARDWOOD FLOORS

"American Hardwood Flooring and Its Uses" is the title of a splendid booklet issued by the United States Department of Commerce — Forest Products Division. It may be obtained by writing to the Superintendent of Documents, Washington, D. C.

140. NICKEL

The International Nickel Company are issuing a small magazine called "INCO." It contains some excellent photographs and articles pertinent to nickel and its uses. This will be a regular quarterly publication. Send for a copy by using the coupon.

141. HARDWOOD LUMBER

Again we have an old friend—the little "Bruce Every Month" magazine, issued by the E. L. Bruce Company. A booklet containing interesting facts and photographs about hardwood lumber.

142. USES OF LEAD

The Lead Industries Association have sent us an advance copy of "Lead," their regular monthly booklet in magazine form and, as usual, it has some very pertinent information on the uses of lead in the building industry. Send for a copy.

143. GOOD READING

The Mueller Company's "Mueller Record" is off the press for November and filled with notes, pictures and some very fair jokes, all of which fill twenty or more readable pages. Clip the coupon.

144. "SEALAIR" FEATURES

"Sealair Double-Hung Windows," a product of the Kawneer Company, is illustrated in two new brochures just received. The advantages of this type of window are very well explained and the illustrations are clear. The coupon will bring you a copy.

145. STEEL COLUMNS

The Union Metal Manufacturing Company have issued a booklet called "Classical Columns for Modern Buildings." The columns here depicted are of fluted steel and all the classical architectural types are shown, with dimensions and details.

146. WASH FOUNTAINS

The Bradley Washfountain Company have brought out another of their broadsides and this one illustrates a washfountain for a small washroom in schools, shops, etc. The coupon will bring you a copy.

147. NEW SHINGLE

From the Celotex Company comes a notice of a new product, "Shad-O-Grain," a shingle with a raised grain in various colors. This gives a weathered wood effect and with deep shadows. Send for a copy of the book which tells all about this new product.

148. QUIET VALVES

Last month we mentioned a new product by Sloane Company—a quiet valve for bathrooms. The booklet illustrating this new equipment has arrived and it should prove of more than ordinary interest. Its uses in various types of building is manifested in the booklet. The coupon will bring you a copy.

149. KEEP OUT THE COLD

Window Conditioning with double glass insulation by Libby-Owens-Ford Glass is the subject of a brochure put out by the above company. In it will be found data pertinent to the architecturally important subject of windows in the modern home.

150. INSULATION

The American Hair and Felt Company has a new booklet on Insulating and Cushioning materials, several of which are illustrated in color. Send for a copy by clipping the coupon.

FREE FOR THE ASKING

Check items on coupon, paste on letter head or postal card, and mail to Architect and Engineer.

Architect and Engineer
68 Post Street
San Francisco, Calif.

Please send me literature on the following items as checked below. This request places me under no obligation.

- | | |
|------------------------------|------------------------------|
| 137 <input type="checkbox"/> | 144 <input type="checkbox"/> |
| 138 <input type="checkbox"/> | 145 <input type="checkbox"/> |
| 139 <input type="checkbox"/> | 146 <input type="checkbox"/> |
| 140 <input type="checkbox"/> | 147 <input type="checkbox"/> |
| 141 <input type="checkbox"/> | 148 <input type="checkbox"/> |
| 142 <input type="checkbox"/> | 149 <input type="checkbox"/> |
| 143 <input type="checkbox"/> | 150 <input type="checkbox"/> |

My Name

Name of Company

Street

City State

ASPHALT ROOFING

Few building materials combine the desirable characteristics of beauty, long-life and low cost as do mineral surface asphalt shingles, siding and roll roofing. Although these products have been on the market for many years, each year sees their wider acceptance by architects, contractors and the public.

Changes in these products are not spectacular. Many of the improvements which have brought them long-life and beauty have been accomplished by improving and changing the chemical composition of the materials used in their manufacture, and by more efficient factory methods, the latter contributing, also, to their low cost.

While most of the improvements made in recent years are not visible to the eye, there is one notable exception—the composition of the mineral granules which are embedded in the weather-side of the products.

By improving these tiny granules, chemists and engineers have, among other things, made possible the manufacture of roofing in a wide variety of colors. They have kept pace with the demands of a public which has become increasingly color-conscious—as evidenced by the brilliant hues of clothing, house furnishings, automobiles, etc.

Dr. Elbert C. Lathrop, vice-president of The Celotex Corporation, himself a chemical engineer, says that chemistry's contribution of color is only one of the improvements made in the mineral granules. Improved, also, are their durability.

Two types of granules are used by manufacturers of asphalt roofing. One is a natural mineral slate, being typical of this variety. The other type is a ceramic, and it is chiefly through this ancient art that modern science has helped give asphalt roofing its new beauty, and longer life.

The original purpose of adding a mineral surface to roofing was to protect the asphalt from the elements, especially from the powerful ultra-violet rays of sunlight, and from the solar heat. Sunlight, if unobstructed, may oxidize the asphalt, causing it to disintegrate—to become dry, cracked, and to flake away.

But, says Dr. Lathrop, the quality of being opaque to sunlight is not enough. The granules must, at the same time, have a surface which is not porous to water; must have a color which will not be faded by prolonged exposure to the sun's rays; and must collect the minimum amount of dirt.

Ceramic engineers and chemists have, for many years, conducted extensive research into the production of glazes which will give brilliant, fade-proof colors. The results of these investigations are applied to the manufacture of mineral granules for asphalt roofing materials, says Dr. Lathrop.

Asphalt roofing—shingles, siding and, to a lesser

extent, roll roofing—are now made in practically all colors and blends. Architects or owners may select a covering which will harmonize with, and be a part of, any desired color scheme of home or factory.

Outside of the scope of color, but nevertheless a problem in the production of mineral surface roofing is the tendency of granules to pick up and hold dirt and dust. Artists know that color dulling is produced by adding black to a color. Manufacturers have found that some types of granules gather and retain dust while others are singularly free from this tendency to add dulling black to their bright colors. Constant research is helping produce mineral surface asphalt roofing which keeps the beauty of its sparkling colors exposed for all to see.

Chemists and engineers engaged in making asphalt roofing materials test their products in actual use. But natural weathering is too slow for the research workers. They imitate and speed up weathering by artificial means. Powerful electric lamps, whose light is rich in the destructive ultra-violet rays, take the place of sunlight in the tests. High-pressure whirling sprays of water imitate summer rain storms. Mechanical refrigeration produces sub-freezing temperatures. By alternating these man-made elements of nature throughout the day and night, in one month asphalt roofing is given the same punishment it would receive in approximately one year of service on a building.

\$700,000 HIGH SCHOOL

The office of Will P. Day, San Francisco, is at work on preliminary drawings for a group of High School buildings to be known as the Outer Mission Junior High School and consisting of 26 class rooms, library, assembly hall, gymnasium, shops, cafeteria, etc. Albert F. Roller is to be associated with Mr. Day on the project, expected to entail an expenditure of more than \$700,000.

W. W. WURSTER BUSY

New work in the office of William W. Wurster, Newhall Building, San Francisco, includes a new front to the Terminal Hotel, San Francisco; Argentine Exhibit Building at the Exposition and a seven room residence in Santa Cruz for Fred T. Hale.

VISITACION VALLEY SCHOOL

Messrs. Hyman and Appleton and G. A. Lansburgh have completed drawings for a kindergarten addition to the Visitacion Valley School for the City and County of San Francisco.

DESIGNING EIGHT RESIDENCES

Eight five-room dwellings will be built in the Sequoia Tract, San Jose, from plans by Charles S. McKenzie of that city. The owner is T. H. Herschbach who will invest \$50,000 for the improvements.

LOS ANGELES IN DEFINITE NEED OF HOUSING

THE need of better and more adequate housing was stressed by William Burk, a member of the Los Angeles County Co-ordinating Council, at the November meeting of Southern California Chapter, the American Institute of Architects, at which he was the principal speaker.

That a very definite need for new housing exists in Los Angeles, to replace existing sub-standard houses, is Mr. Burk's belief. Figures he submitted indicate that in the more congested parts of the city, representing 2 per cent of the area and 15 per cent of the population, a replacement of 50 per cent of the housing is needed.

These areas, he said, have police and health costs that greatly exceed the per capita costs for similar services for the entire city, and this condition can be traced to poor housing conditions. According to Mr. Burk, poor housing breaks down ethical standards and standards of good conduct, and tends to destroy real estate values. He stated that large areas adjoining the poor housing districts have been blighted and, that for a good city, these areas must be kept from spreading. Mr. Burk believes that these conditions will be corrected and that Los Angeles is on the verge of the biggest rebuilding program of its history.

C. H. Fennell, executive director of the Los Angeles City Housing Authority, stated that a loan contract application for the slum clearance project east of the Los Angeles River has been filed with the authorities in Washington, but that several matters, including equivalent demolition, have not yet been ironed out. He believes, however, that the demolition requirement may be overcome by inducing the government to consent to bringing about 85 per cent of the existing sub-standard houses up to standard.

Walter W. Alley, a member of the Los Angeles City Housing Authority, stated that one of the first requirements of a project of this kind is that a need must be shown for new housing. No such survey has been made, he said, particularly as it effects the low-income group, but such a survey of the entire metropolitan area of Los Angeles may be under way shortly as a P.W.A. project.

The nominating committee for Chapter officers and directors for 1939 reported as follows: Eugene Weston Jr., president; Edgar Bissantz, vice-president; Ben H. O'Connor, secretary; Earl T. Heitschmidt, treasurer; Samuel E. Lunden, director for the three-year term.

Committee reports were made by Earl Heitschmidt on Construction Industry meetings, by Donald Kirby on public relations and by Eugene Weston Jr. on the California Construction Congress of the State Chamber of Commerce, which met in Fresno November 16.

Herbert Powell, reporting on the honor awards program, stated that the jury would make its report at the February meeting. He said there have been ninety-two entries to date.

OREGON-WASHINGTON ARCHITECTS MEET

A joint meeting of the Oregon and Washington Chapters, The American Institute of Architects, was held at Timberline Lodge, November 5 and 6, and was attended by eighty members, associates and wives (exactly forty from each Chapter), delegates coming from Twin Falls, Idaho; Spokane, Bellingham and Klamath Falls, as well as from Seattle, Tacoma and Portland.

Guests convened at the Multnomah Hotel in Portland early Saturday morning and the out-of-state delegation formed the first caravan for a side trip to inspect the Bonneville project. The second caravan traveled directly to Timberline.

A joint business meeting was held Sunday at which, among others, the following resolutions were passed:

"Resolved, That the Oregon and Washington Chapters of the American Institute of Architects, in joint meeting assembled on November 5 and 6, 1938, at Timberline Lodge on Mt. Hood, Oregon, do hereby commend the Works Progress Administration and the United States Forest Service for the high architectural standards conceived and maintained throughout the design and construction of this building, but regret that suitable recognition in the form of a bronze plaque was not given to the men who were technically responsible for such an outstanding creation. It was felt that such a building cannot be developed without architectural ability of a very high order and that such ability should be given proper public recognition.

"It is further resolved, That both the Oregon and Washington Chapters of the American Institute of Architects, in joint session assembled, go on record as favoring adequate legislative action by both states for control and proper development of land use on both sides of the Columbia River to preserve the natural beauty of this region."

At the end of the business session, which involved many other matters professional in nature, it was moved and passed that the two Chapters exchange monthly minutes and keep each one posted on the other's activities, and, in lieu of adjournment, that a recess be called of not more than one year's duration, and that the next joint meeting be held at Spokane and Grand Coulee.

HOUSING IN ITS INFANCY

According to Nathan Stross, administrator of the United States Housing Authority, the rehousing movement is only in its infancy. The government program can provide, with funds now available, only about 150,000 new homes. This is a drop in the bucket compared with the need.

The private building industry today is building homes within reach of only about one out of three families in the population. It is doing one-third of a job, of which eventually it must do, in the belief of Mr. Stross, at least two-thirds.

JOHNSON

Since 1904, the name of Johnson on an oil burner has been accepted as the seal of fine engineering, skilled craftsmanship and dependability. Johnson Burners on an architect's specifications insure satisfaction and comfort for the home owner. Johnson builds oil burners for every need of industry, commerce and home. Data sheets on each type of Johnson Improved Burners give complete information and specifications. Johnson engineers will be glad to assist in preparation of layouts & estimates.



THERE'S A JOHNSON OIL BURNER FOR EVERY PURPOSE

AIR-CONDITIONING? See the Johnson SELECTAIR, a compact, efficient unit which offers every desired feature for economical heating, air-conditioning and ventilating the home. With year-round domestic hot water. Oil-fired by the Johnson Pressure-type "Bankheat" Burner.

BOILER-BURNER UNIT? Test the "LADDI DU-ALL", a compact and completely automatic unit furnishing heat and hot water for small and medium-sized homes and apartments at low initial cost.

... Descriptive bulletins on request.

S. T. JOHNSON CO.

940 ARLINGTON, OAKLAND, CALIFORNIA
401 N. BROAD STREET, PHILADELPHIA, PA.

INSULATING MATERIALS RESEARCH

The University of Toronto has become the first Canadian institution of higher learning to associate itself with the research activity of the American Society of Heating and Ventilating Engineers. Under a cooperative agreement, announced by W. L. Fleisher, chairman of the Committee on Research, and made effective in July this University will make a special study of the physical properties of insulating materials, giving special consideration to the macro and micro structure of the cellular arrangement of the material.

Addition of the University of Toronto makes two large institutions now working on insulation problems; the other being the University of Minnesota, where Prof. F. B. Rowley has been engaged for an extended period in various insulating material tests. The technical advisory committee on insulation is chairmanned by Lt. Col. W. A. Danielson.

IMPROVED BUILDING MATERIALS

New construction developments, including welded designs for houses, metal for building fronts, color-fused plate glass, residence elevators, and ingenious kitchen units and heating arrangements, are making homes and buildings more livable and decorative, according to a research bulletin edited by the structural service department of the American Institute of Architects from data provided by the Producers' Council.

The approval of welding in the new building code of the city of New York has resulted in wider recognition of the advantages of structural steel welding for better housing design. It is estimated that today there are thousands of structures erected with welded joints, some of which comprehended shop riveting and field welding, others shop welding and riveting in the field, while a large percentage were completely welded.

"It is anticipated that those cities the building codes of which do not at present include the sanctioning of structural steel welding will fall in with the parade as it gains momentum," says the bulletin. "Structural steel producers have recognized the demand for light weight steel members through the manufacture of a variety of such shapes.

"Steel frame construction permits a greater latitude of design and offers permanency, since shrinkage and corrosion are practically eliminated. It is both fire resisting and vermin proof, and affords safety from lightning. Its cost is comparable to other standard means of construction.

"The acceptance of steel frame construction is being achieved through the application of the fusion welding processes as a simple and effective means of joining structural assemblies. Here the builder's saw is displaced by his cutting torch, while hammer and nails are supplanted by fusion welding.

"Weight reduction is one of the most important factors made possible by welding because it eliminates the use of rivets, bolts, clips and fish plates. The full section of the member is available for stress. Welded joints allow for the conservation of space through elimination of bulky connections and provide more rigid construction."

Structural welding is adaptable to house construction over a wide price range, it is pointed out. The bulletin describes two homes, one costing \$7,900 and the other \$35,000. In the first, the cost of welding per cubic foot was \$0.0125; in the second it was \$0.0093.

Plate and Structural Glass

The growing practice of incorporating luminous elements as a part of the architectural design has been the incentive for production of new plate and structural glass. One colored type is from three to seven times stronger than ordinary plate glass and can stand extreme heat or changes in temperature. According to its makers, if it is subjected to the extreme force necessary to break it, the entire sheet will disintegrate instantly into small crystals about the size of bath salts.

This plate glass can be used wherever it is desired to transmit light through plane surfaces instead of merely reflecting light or having lighting elements attached. Entire walls and ceilings, light panels in ceilings and bathroom and other recesses can be lighted in this way, in addition to exterior areas. An opaque variety also is suitable for building fronts, interior walls, wainscotings and ceilings, and table tops.

Another structural glass has tensile strength and resistance to wear greater than that of marble. Opaque, with a high luster, it is said to be impervious to burns from cigarettes, acids in common use, moisture and weather. It comes in plain and agate colors.

A new principle in building front construction consists of extruded metal which eliminates all plain, flat surfaces that are prone to give the optical illusion of waviness. Each distinct area has a slight radius. A casual wiping of the surface, perhaps as part of window-washing routine, will bring out the high points of the designs in contrast with the lower portions of the profiles, it is explained. This accentuates the contrast between light and shade, which is the main object of molding profile design.

Residence Elevators

The time is close at hand when an elevator will be included in the plans of every modern home, one manufacturer believes. A wide range of hand and electrically operated outfits are now available to meet the problem of where and how to fit a residential elevator into an existing structure without needless sacrifice of space and costly alterations.

Among these is an electric stair carrier having two hinged seats and a foot rest which travels on a steel rail at one side of a straight flight of stairs. When not in use, the seats and foot rest fold against the carrier, occupying but seven inches from the side wall of the stairway.

Where there is an open stairwell, a type operated up and down the well by the endless hand rope gives individual service. When general passenger as well as individual service is required, an electric installation is recommended. The car travels on a single guide rail, and when it is at the upper floor the lower hallway is free and the presence of an elevator is not obvious.

If a completely enclosed shaft is wished, existing closets one above the other may serve. But if space on the lower floor is limited, an elevator can be installed without an enclosure on that floor. The car is run to the upper floor when not in use.

The selection of a sink which is designed to give greater kitchen efficiency, comfort and convenience is the best approach to a modern, livable kitchen because almost all activity in the kitchen involves the use of the sink, the bulletin continues. Exhaustive studies of kitchen tasks in households of every type have prompted the development of equipment embodying many refinements which lighten the kitchen duties of housekeeping.



For GAS HEAT choose the **DELCO CONDINAIR**

Built and Backed by General Motors

• This extremely efficient unit automatically warms, purifies, humidifies and circulates the air—supplies complete winter air conditioning to which summer cooling can easily be added. A quality product of unusual efficiency with the plus value of the "General Motors" name. Also models for oil heat. Get complete specifications from —

ALADDIN HEATING CORPORATION

2222 SAN PABLO AVENUE • OAKLAND

**Pressure
Treated Lumber?**

Specify

BAXCO C Z C

**"Chromated Zinc
Chloride"**

**Protects against decay
and termite attack**

•
*Available for prompt shipment
throughout California*

•
J. H. BAXTER & CO.

601 W. 5th Street
LOS ANGELES
Phone Mlchigan 6294

333 Montgomery Street
SAN FRANCISCO
Phone DOuglas 3883

NEW KRAFTILE 6 x 9's "OPEN UP" CONSTRICTED AREAS

Set in Master Kraftile 6 x 9's, small wall surfaces "open up" horizontally or vertically, according to the way these extra large tiles are set. Walls also gain an added beauty from Master Kraftile's rich colors. And a more durable glaze, because Master Kraftile is higher fired (its color goes deeper) than ordinary tile.

These large 6 x 9's now cost no more installed than 4¼ x 4¼'s. They're quicker to set. And like all Kraftile, they have an unusual affinity to mortar.

Write for free copy of illustrated folder. Kraftile Company, Niles, Cal.

See your Sweet's: Catalog 5, Section 11

Right: Wall surface set in new 6" x 9" Master Kraftile. Note low space "opens up."

Below: Same size surface set in old-fashioned 4¼" x 4¼" tile. Space looks "tight" in comparison.

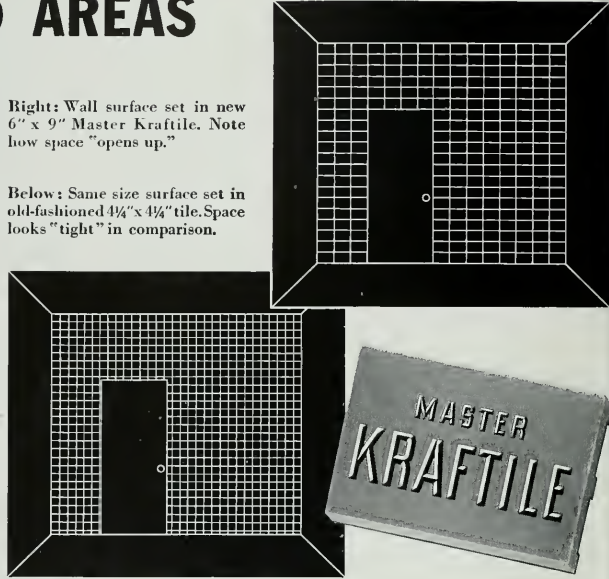

One sink has two compartments for dishwashing and food preparation. Space for knees in kitchen cabinets permit the housewife to assume correct posture and prevents fatigue while working. Top storage cabinets come in different sizes, with and without concealed interior lighting.

Better Heat Distribution

In the heating field, a new principle of distribution involves a unit concealed within the walls of every room and bringing instantaneous circulation of warm air without the disadvantages of air ducts. A small, silent fan, driven by compressed air, blows across a copper finned radiator through which warm water circulates. The system is said not only to warm a room in from three to six minutes, but to keep the air moving and maintain an even temperature with but three degrees difference between floor and ceiling. No floor space, studding or insulation is necessary, and no air is recirculated from room to room.

Another system provides a different uniform water temperature in the radiators to offset the heat loss of the building for different outside temperatures. It also eliminates stratification of the air in the room, for as long as heat is needed the temperature of the water in the radiator is always above the temperature of the air in the room, so that the air is kept in circulation.

Copper tubes and fittings for heating systems are in demand, it is pointed out, because of the attractive appearance of these non-rust, uninsulated, polished and lacquered materials.

HEATING ENGINEERS TO MEET

The forty-fifth annual meeting of the American Society of Heating and Ventilating Engineers, to be held at Pittsburgh, Pa., January 23-26, 1939, will be in the nature of an observance of the twentieth anniversary of the establishment of the A.S.H.V.E. Research Laboratory, which occurs in 1939.

Special emphasis at the technical sessions will be laid on research problems. These will include such topics as air conditioning in industry as related to health of workers, physiological sensations of comfort, hospital air conditioning, characteristics of reflective insulation materials and the heat requirements of single and double glazed houses; also condensation of moisture within walls of buildings, heat transfer in storage water heaters, recent advances in physiological knowledge in relation to ventilation practice, problems of air flow in ducts and weather design factors which influence air conditioning applications.

More than twenty papers in which some thirty-five engineers, medical scientists and public health authorities will participate, have been scheduled for presentation at this meeting.

ADDITION TO HOME

Alterations and additions will be made to one of the residences at the Protestant Episcopal Old Ladies' Home, 2770 Lombard Street, San Francisco, from plans by F. Eugene Barton, Crocker Building, San Francisco.

GRADED STANDARDS NEEDED

THE "American standard of living" is a myth, according to George H. Gray of New Haven, Conn., chairman of a subcommittee of the American Institute of Architects, which is studying basic principles for the national housing movement. It means one thing for one income, and other things for every other income, Mr. Gray says.

"The housing problem is so extensive that it is of the utmost importance that the standards which we establish shall be sound—neither so costly as to slow up the program nor so skimmed as to miss the fundamental purpose. The crux of the problem lies in the determination of what are reasonable standards of living.

"Let us concede that healthy living is the criterion and that aside from merely biologically sanitary housing we must have housing making for efficiency and cheerfulness, with facilities for recreation for all ages. But where draw the line? Thrift and frugality are still virtues not to be lost in exchange for indulgence and luxury. Rehousing so large a proportion of our population is a program so extensive that in order to reach all those needing better housing there must be no over-reaching for unwarranted high standards of living."

During the coming year the A.I.A. group headed by Mr. Gray will make an intensive study of certain features which originated in the P.W.A. program for subsidized housing, and which if not modified by early action may, it is held, become crystallized as a standard, to the detriment of the future U.S.H.A. work. Organized investigation and action in "the great No Man's Land of incipient slum areas" is said to be needed. Ways to bring into greater activity non-subsidized housing as undertaken by private enterprise must be found, it is pointed out.

"The P.W.A.," Mr. Gray continues, "made an admirable start in analyzing the national housing problem, in establishing standards and procedures, and in establishing a point of departure for future work, but it was only a start. That work was done by a highly centralized Federal organization, with local talent co-operating. The current and the future work under U.S.H.A. will be highly localized, with the U.S.H.A. at Washington co-operating. That is a distinction of fundamental significance.

"The development of good public housing from now on rests very largely with the local housing authorities and the local architects. It is a challenge to the communities to put their most enlightened citizens on their housing authorities and to the architectural profession to make their ablest contribution in solving an immense and fascinating problem.

"To accomplish its end the new housing must be enduring. Only such design and construction as is of proven value must go into the houses; yet without losing these there is good reason to believe that there can be a very appreciable scaling down from the high initial standards wisely set by the P.W.A. Those standards

ANNOUNCING "ALUMILITE" ALUMINUM VENETIAN BLINDS

The Only Window Insulation
in the World

**SUPREME LIGHT CONTROL
NOW**
EXCLUSIVELY IN CALIFORNIA
by

MacDONALD 
HARDWARE MANUFACTURING CO.

YUkon 0123

963 Harrison St.

San Francisco

"Goods of the Woods"

**Dependable
Building
Materials**

**Lumber and Millwork
for
All Types of Construction**

★

**Wolmanized or Creosoted
Lumber and Timbers
is your protection against
Termites and Decay**

★

E. K. WOOD LUMBER CO.

San Francisco

Los Angeles

Oakland

"IT'LL COME OUT IN THE WASH!"

"It'll come out in the wash" . . . that DAY AND NIGHT, America's finest water heater is the most prolific and dependable source of hot water for not only the washing of clothes, but for the many household requirements that are indispensable to a well-groomed family.



CUTS GAS BILLS.

You can replace your old water heater and a DAY AND NIGHT will pay for itself in your home by cutting your gas bills 33 1/3%. Don't tolerate an old wasteful type of water heater when you can enjoy the convenience and luxury of plenty of hot water always on tap—day and night—for baths, showers, dishes, laundering, cooking and housework.

DAY AND NIGHTS are easy to buy . . . monthly payments are only a few dollars. See or phone your Day and Night dealer now.

Spring Byington, mother of 20th Century-Fox's famed Jones family. Current release "Down on the Farm."

DAY and NIGHT WATER HEATER COMPANY
MONROVIA, CALIFORNIA

STANLEY

THE SYMBOL OF LEADERSHIP
IN DOOR HARDWARE FOR 90 YEARS

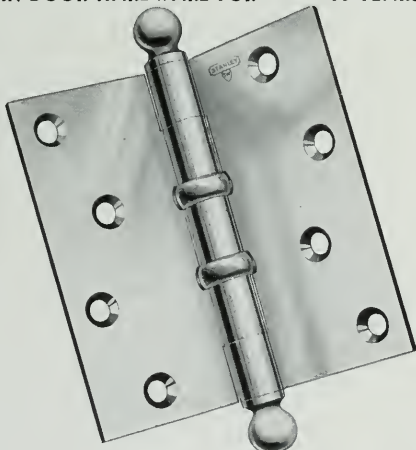

THE STANLEY WORKS
New Britain, Conn.

SAN FRANCISCO
576 Monodnock Bldg.

LOS ANGELES
407 American Bank Bldg.

SEATTLE
568 First Avenue, South

STANLEY

TRADE MARK

HARDWARE FOR CAREFREE DOORS

made the housing projects available only to the very best financial risks in the slum areas, the marginal families, and they are not the ones whose need is greatest.

"As the experience of P.W.A. projects have demonstrated and as is demonstrated by the experience of other countries, there is need for a more careful analysis of the types of families and of individuals needing housing and of their varying scales of income—so well achieved in Holland."

BAY BRIDGE TWO YEARS OLD

Two years ago last November 12 the San Francisco-Oakland Bay Bridge was officially opened to traffic.

Since then approximately 17,800,000 vehicles, transporting more than 39,160,000 persons, have crossed the great span, according to Chief Engineer C. H. Purcell.

Up to November 1, 1938, the bridge has earned a total of \$9,480,514.31, with a daily average since the span opened of 24,388 vehicles.

"In the past year," Mr. Purcell said, "the San Francisco-Oakland Bay Bridge has stimulated transbay traffic approximately 300 per cent over the pre-bridge year 1935, and the total number of persons transported across the span would find its equivalent if every man, woman and child of San Francisco and Alameda Counties crossed the bridge thirty-six times. The bridge is unquestionably not only paying for itself in terms of revenue, but also in terms of business stimulation for the Bay Area and its surrounding territory through the time saving and convenience of its facilities."

Traffic has shown a general increase this year over last year, Mr. Purcell announced. Automobile traffic has increased .27 per cent; buses, 30.04 per cent; trucks, 47.80 per cent, and number of freight pounds, 57.20 per cent. From opening date, November 12, 1936, to November 1, 1938, 16,259,399 passenger automobiles, 61,073 motorcycles and 220,779 buses have used the bridge. A combined total of 676,525 trucks and truck trailers has carried a total of 1,591,338,326 freight pounds.

The Bay Bridge tow service has given aid to 13,507 vehicles since the span opened, to November 1, 1938, or to one out of every 1,298 cars crossing the bridge. This is an average of 18.79 per day. Lack of gasoline was the source of trouble of more than half the motorists, with 7,389 calls registered during the two-year period. There were 4,009 vehicles towed and 2,034 tires changed. The Bay Bridge's own fire department put out 69 vehicular fires. Calls for Bay Bridge service are made by motorists through the red tow-call boxes placed along both decks of the span and on the distribution structure.

Exposition traffic also provided an important item in the year's report, according to Mr. Purcell. The total number of automobiles traveling to the Exposition during the year to November 1 was 76,950. Other totals include: Trucks, 14,725; buses, 389; motorcycles and trailers, 296. There was a total of 99,643,237 freight pounds transported to the Exposition.

The Bay Bridge highway still remains one of the safest in the nation, with 106 accidents occurring on the span proper in the past two years out of a total of 17,534,944 vehicles crossing the bridge to November 1, 1938. This indicates that for every 165,424 vehicles crossing the span, there was one accident. One hundred and seven persons were injured in accidents on the bridge out of an approximate total number of 38,576,877 persons crossing the span as of November 1.

Construction of the Bay Bridge Electric Railway Facilities is nearing completion, and operation of inter-urban trains will start January 15.

THE EDWARD LANGLEY SCHOLARSHIPS

Attention is again called to the forthcoming awards of Edward Langley scholarships for advanced study, research and travel.

The grants, which will be limited to ten, with no stipend exceeding \$1,500, are open to architects, architectural draftsmen, graduate students and teachers of architecture in the United States and Canada. Established in 1936 by the estate of the late Edward Langley.

Architects may propose any other architects or architectural draftsmen as candidates for the awards to the Regional Director of the Institute who represents the district in which the proposers and candidates reside. Scholarships will be bestowed according to the character, ability, need and purpose of each candidate. The Regional Directors may ask any candidate to submit examples of his work and to appear before them or their representative.

"To avoid unnecessary disappointment, a candidate should not be suggested unless his qualifications are outstanding and it is evident that the profession will be benefited by an award to him," the announcement said. Proposals will be received from January 1 to March 1, 1939.

Graduate students and teachers of architecture who wish to apply for the scholarships must be proposed by the faculty or head of architectural schools approved by the Institute, to the Institute's Committee on Education, of which C. C. Zantzing of Philadelphia is chairman. Final awards, determined by the Institute's Investment Committee from nominations submitted by the Regional Directors and the Committee on Education, will be announced about June 1.

All proposals are to be made in duplicate on printed forms obtainable from the American Institute of Architects, 1741 New York Avenue, Washington, D. C. Undergraduates are not eligible for the scholarships, but architectural draftsmen who plan to do undergraduate work or take special courses in architectural schools may be proposed. A second award to the holder of a scholarship is allowed. No candidate may propose himself.

The Investment Committee of the Institute, which makes the final selection, consists of Edwin Bergstrom of Los Angeles, chairman; Albert J. Evers of San Francisco, and Robert K. Fuller of Denver.

No Worry for the Architect

"— All acid proof drain pipe and fittings shall be ferro-silicon CORROSIRON —"

[Write for this specification]



FEDERAL BUILDING • CIVIC CENTER • SAN FRANCISCO

Arthur Brown, Jr., Architect

CORROSIRON DRAIN LINES and FITTINGS and LABORATORY EQUIPMENT was specified because of its superior resistance to corrosion and wear.

Pacific Foundry Company, Ltd.

NEW YORK • 3100 NINETEENTH ST., SAN FRANCISCO • LOS ANGELES

BUILD WELL~

A PROPERLY designed and well constructed building is a credit to any city and a profitable investment for its owner.

Such structures are the STANDARD OIL BUILDING, MATSON BUILDING, FOUR-FIFTY SUTTER STREET, STOCK EXCHANGE, S. F. BASE BALL PARK, MILLS TOWER, OPERA HOUSE and VETERANS' MEMORIAL, San Francisco, OLYMPIC CLUB ALTERATIONS, SANTA ANITA RACING PLANT and other notable structures — all built or supervised by —

Lindgren & Swinerton, Inc.

Standard Oil Building 605 W. Tenth Street
San Francisco Los Angeles

We Maintain a Termite Control Department

POMONA TILES

FOR
Bathrooms and Kitchens
in over 60 colors

Warehouses and Display Rooms

135 Tenth St. San Francisco
629-33 North La Brea Ave. Los Angeles
6106 Roosevelt Way Seattle

POMONA TILE MFG. CO.
PLANT — POMONA, CALIF.



SPECIAL lighting equipment for distinguished residences is no longer required. Now Lightoliers, in all periods, for all locations, styled and constructed from expensive "specials" are available at low cost — through dealers or at our showrooms. Send for "The Charm of a Well Lighted Home", an informative manual on correct residential lighting.

INCANDESCENT SUPPLY CO.
SAN FRANCISCO : OAKLAND : FRESNO : LOS ANGELES

HARER GAS FURNACES HEAT

Consult us for the answer to your problems

HARER-PERRY COMPANY

5662 Keith Ave., Oakland, California
Phone HUmboldt 7928

A Permanent Exposition
of the newest ideas
in home planning
and equipment.



THE BUILDING MATERIAL EXHIBIT
Architects Bldg. • Fifth & Figueroa • Los Angeles • MU-6306

THE NEED FOR PAINT STYLING

BY FRANK JONES

A FEW years ago many of us cared very little about this or that particular style, but today we find ourselves perfect slaves to fashion; and what is fashion but the style of today? Human beings are largely creatures of habit, and whereas being stylish was a fad intended mainly for the rich a short while back, today it has become a habit indulged in by all. We are living in an age of style. Almost everything we see, hear, taste, smell or handle is stylized, and, what is more we are becoming more style conscious every day.

Industrialists, ever alert, were quick to sense this change of being stylish from that of fad to habit, and immediately seized upon it as a sales promotional scheme. Each move in their manufacturing and selling plan was designed to create new ideas by which their product could be changed so that it would have an individual style. It mattered not what he was offering the public for sale—it might be automobiles, clothing, food, probably tooth brushes, or even the lowly cook stove—it had to be different. He packaged it differently, merchandised and advertised it differently, probably paid experts large sums of money to bring about these differences. Why was the industrialist so willing and anxious to change his product, which had probably been sold for generations as it was at that time, and why was he willing to pay experts for their efforts in revamping his product? It was because he realized that we were entering upon an era in which style would play a most important part, an era in which style, more frequently than any other factor, would influence sales.

We of the paint industry were unquestionably style conscious when this new era dawned, but in a measure we stuck to our traditions and continued to sell insurance, cleanliness, durability, etc., with a certain amount of style thrown in, until suddenly we realized that we had not made the most of our styling opportunities. We had not gone the limit, as it were, in stylizing our product. Also other industries were making inroads into our business; something had to be done to counteract this condition and make us more sensitive to style trends. As a consequence, the Council for Paint Styling was formed to study this situation and see what steps could be taken to correct it. As this was an entirely new venture as an association activity, a great deal of planning and fact finding had to be done.

Will the work of the Council for Paint Styling help the contracting painter and decorator increase his sales and thereby make it necessary for him to buy more paint? In my judgment it will, and the efforts of this group will offer a glorious opportunity for co-operation between the paint manufacturer and painting contractor, the Council for Paint Styling acting as mediator between these two branches of the industry.

I am sure we are all convinced that the need is urgent, and especially so when we stop to consider the amount of wall paper, finished fabrics, finished wall

board and many other products of similar nature which do not require painting, which are being used today on surfaces that were formerly painted. Why are these products being used in ever increasing volume? It is because the styles of today decree it to be the smart thing to use in greater proportion the lovely wall papers, which are yearly growing in beauty, refinement and perfection of design. It is also considered the smart thing, as well as the economical, to cover your bathroom and kitchen walls and ceilings in highly finished wall board which will never require painting. It is the smart thing to cover beauty parlors and barber shops and other such places in wall linoleum which will never need painting, and I could go on naming various treatments that are considered smart at the present time because style so decrees, and each time that style decrees that something be used which does not require painting on surfaces that were formerly painted, the painter and paint manufacturer are the losers.

Not only do we wish to hedge against inroads made into our industry by other businesses, but we want to improve and perfect our own industry to the point that we can reclaim at least a portion of that which has been lost and also probably make inroads on others. In my judgment, the surest way to accomplish this is by out-styling the other fellow.

I have the feeling that the paint industry accepts too conclusively the idea that it is a service industry. I think we should shake off this idea, and realize that in addition to being a service industry, we are an industry capable of creating and selling style to the public. The Council should predict the trends that will be seen in painting, rather than simply report the types of painting being used at the present time and the proportion in which each is being used, in other words we should be originators of style, rather than mere followers.

"TOM THUMB" HOUSES

Silas E. Nelsen, architect of Tacoma, has been commissioned by Better Homes and Gardens magazine to design five houses of three to five rooms each, which are to follow the lines developed by Mr. Nelsen in his well-known "Tom Thumb" houses.

PRODUCTS

VAN ARSDALE-HARRIS CO.
ENGINEERS & CONTRACTORS

ACOUSTICAL TREATMENT - INSULATION
SOUND CONTROL

FIFTH & BRANNAN STS. SAN FRANCISCO, CALIF.
TELEPHONE GA 4field 3600
DIVISION

VAN ARSDALE-HARRIS LUMBER CO., INC.

**INCLUDE TREES
IN YOUR PLANS**

DAVEY, ORIGINATOR OF TREE SURGERY, OFFERS FREE
INSPECTION AND ESTIMATE.



**DAVEY
TREE**
SURGERY CO., LTD.

SAN FRANCISCO Fresno LOS ANGELES
 Russ Bldg. Mattei Bldg. Story Bldg.
 SUTTER 3377 TUCKER 1929
 Local phones in: Pasadena, Palo Alto,
 Oakland, San Rafael, San Mateo

SKILL - KNOWLEDGE - RESPONSIBILITY

STRUCTURAL STEEL

For Class A Buildings,
Bridges, etc.

JUDSON PACIFIC CO.

609 MISSION STREET
SAN FRANCISCO

Plants: San Francisco - Oakland

USE BASALITE

Light-weight, pre-fabricated Con-
crete building products for floors,
walls, and roofs in your next
building.

BASALT ROCK COMPANY, INC.
Napa, California

NOISE *Control*

Office Quieting
Sound-proof Partitions
Acoustical Correction

WESTERN ASBESTOS CO.

Building Materials *Mechanical Specialties*
 SACRAMENTO OAKLAND
 SAN FRANCISCO

Who needs an
AGENCY ACCOUNT?



Our Agency Service has sound value for everyone who has difficulty keeping a security portfolio in good order, and who appreciates the real economy of a practical convenience. Let us send you a descriptive booklet, *An Introduction to Agency Service*.

Just ask for booklet M-2

**CROCKER FIRST
NATIONAL BANK**
OF SAN FRANCISCO
California's Oldest National Bank



*No longer a problem
for the Architect*

**TRANSIT
MIX CONCRETE**
AND MORTAR

makes delivery of material to the job swift and inexpensive . . . minimizing the architect's supervision costs and assuring his client a dependable mix.

Speed . . . Reliability . . . Economy
Let us co-operate with you

**Golden Gate-Atlas
Materials Co.**

16th and Harrison Streets
San Francisco
UNderhill 3650

**FAIR STIMULATES INTEREST
IN HOME BUILDING**

Home building will receive direct and definite stimulation from the \$50,-000,000 World's Fair of the West on San Francisco Bay.

Not only will model interiors be shown in the decorative arts show, where twelve room ensembles are being planned by American and European decorators, and in the Homes and Gardens Building, where thirty-two rooms are planned, but unusual small homes will be on exhibit in the outdoor area. Among the houses to be shown here are several steel homes, including one of the new Compton steel abodes, in which all corners have been eliminated, and an all-pine-home by the White Pine Association.

One of the interesting outgrowths of this whole home construction program is the Exposition Model Homes Tour, a series of some forty model houses in the San Francisco area. They will range in price from \$5,000 to \$30,000, and are to be architecturally designed, completely furnished and landscaped. These houses, which will be open to the public from May to September, will be outstanding from the standpoint of modern construction. Wherever feasible, the latest developments in cement, stone, glass, wood, adobe, brick, wallboards and plywood will be used.

The electrical and gas industries are co-operating by providing a special designer to work out a novel and attractive kitchen plan for each house. These houses may be completely equipped with electrical or gas appliances, or a combination of both.

There will be introduced into these houses cove lighting and neon lighting for atmospheric effects. There will be over-mantel hidden lighting for pictures and decoration. Also in some instances there will be lighted fountains behind sculptured glass to add interest and beauty to the homes. Table decorations that seem to be of decorative marble or bronze may turn out to be clever little lighted fountains.

The large glass corporations are

**Modern Design
Dignified and
Good Looking**



Model No. 75

This new semi-recessed HAWS DRINKING FOUNTAIN is made of Vitreous China and answers a demand for an attractive, well built fixture for public and semi-public buildings.

HAWS DRINKING FAUCET CO
1808 Harmon Street Berkeley, Calif.

SISALKRAFT
REG. U. S. PAT. OFF.

**"More than a
building paper"**

THE SISALKRAFT CO.
205 West Wacker Drive
(Canal Station) Chicago, Ill.
55 New Montgomery Street
San Francisco, Calif.

**Pacific
Manufacturing
Company**

High Class Interior Finish
Quality Millwork

142 Sansome St. 6820 McKinley Ave.
San Francisco Los Angeles
GARfield 7755 THornwall 4196

1313 Seventh Street, Oakland
GLencourt 7850



CLIENTS will bless you for installing the Wesix "49'er" ELECTRIC BATHROOM HEATER. But try it first in your own home. Certain that you will like its forty-nine inches of INSTANT RADIANT HEAT and QUICK CIRCULATING HEAT, we are offering this smart new heater at factory cost to architects, for personal use! Limit one heater per architect. List price \$21.50. Please write on your regular letterhead, to: 1018 WESIX BLDG., SAN FRANCISCO

WESIX
WESIX ELECTRIC HEATER CO.

going to make an effort to see that glass is used in new ways in these houses. For instance, we have a good example in the Libby-Owens "Venetian-blind" plate glass, and the glass bricks. There is a very good chance that pre-fabricated cement blocks of a special type may be used in one of the houses. Altogether a great deal of thorough experimentation will take place in these houses, because architects and building material men are anxious to get the reactions of Exposition visitors from all parts of the world.

LARGEST WINDOW ORDER

Reported to be the largest single order for windows in the history of residential construction, the contract for 65,800 Fenestra bonderized steel windows and steel casings, to be installed in the \$50,000,000 community housing project of the Metropolitan Life Insurance Co., located in the Bronx, New York City, has been awarded to Detroit Steel Products Co., according to H. S. Wathen, San Francisco branch manager for this company.

First shipments will be made within the next ten days. The magnitude of this order, which is said to exceed by five times any previous commitment for residential windows, is indicated by the requirement of approximately 100,000 man-hours of labor for its completion, involving 5,000,000 operations, with 10,000 gallons of priming paint applied on the bonderized steel surfaces at the Fenestra factory.

The Metropolitan housing project will embrace a minimum of 171 buildings, ranging from 7 to 13 stories in height, with 200 elevators. It will cover 125 or more acres. There will be five garages, each having a capacity of 800 cars. Dwelling facilities will be provided for some 12,000 families, or approximately 40,000 to 50,000 persons, comparable to the population of Brookline, Mass.; Asheville, N. C.; Elmira, N. Y.; or Lorain, Ohio, or to half the population of the state of Nevada.

For the purpose of making the general plan and furnishing the architectural and engineering services for the design and the execution of the

Pitcher

**Improved
Disappearing Doors
Save 20% Space**

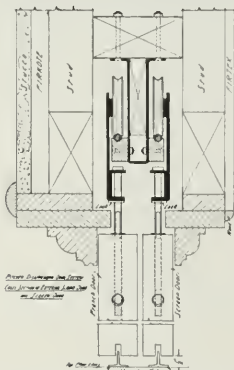

Joins with a 3/4" stud wall . . . steel studs . . . adjustable steel and wood track. Can be used for screen doors in connection with French doors. Send for detail drawing.

E. C. Pitcher Co.
461 Market Street
San Francisco



HERRICK IRON WORKS

STRUCTURAL STEEL
REINFORCING STEEL

18TH AND CAMPBELL STS.
OAKLAND, CALIF.
Phone GLencaurt 1767

FORDERER CORNICER WORKS

Manufacturers of

Hollow Metal Products
Interior Metal Trim
Elevator Fronts and Cabs
Metal Plaster Accessories
Sanitary Metal Base
Metal Cabinets
Flat and Roll Metal Screens
Commercial Refrigerators

269 POTRERO AVE.
San Francisco, Calif.
HEmlock 4100

Donovan Automatic Awning Type Windows

Give 100% natural ventilation
and day-lighting control

UNIVERSAL WINDOW
COMPANY

Berkeley, California

"AMERICAN MARSH" Redi-Vac Vacuum Heating Pump

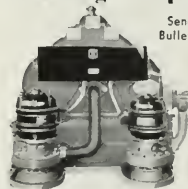

Send for
Bulletin 441

SIMONDS MACHINERY CO.
San Francisco Los Angeles
816 Folsom St. 455 East Fourth St.



SANTA MARIA INN

Santa Maria, California

*On the Coast Highway
between*

Los Angeles and San Francisco

OVER NIGHT

or

JUST A MEAL

FRANK J. MCCOY, *Owner*

Geo. A. Thompson, *Manager*

El Encanto Hotel

Santa Barbara

*On the Riviera, above the
Old Mission*

Frank J. McCoy, *Owner*

Fred F. Pimental, *Manager*

Independent Iron Works

Structural Steel

Ornamental Iron

Steel Service Stations

Steel Tanks

Standard Steel Mill Buildings

Bridges

821 Pine Street

Oakland

Clinton Construction Co.

of California

*General
Contractors*

923 Folsom Street
San Francisco
SUtter 3440

work, a board of design has been created under the direction of R. H. Shreve of the firm of Shreve, Lamp & Harmon. As chairman of the board of design, Mr. Shreve will have associated with him Henry C. Meyer, of Meyer, Strong & Jones, consulting engineers; Gilmore D. Clarke, city planning and landscape engineer, and Irwin Clavan, one of the associated architects on Williamsburg Houses.

PUBLICITY FOR THE ARCHITECT

A series of dramatic motion picture programs designed to show the effect of proper home modernization on family life is soon to be released through the "Consult Your Architect" Motion Picture Council, 551 Fifth Avenue, New York City. The programs are for showing to adult clubs and organizations throughout the country.

F. R. Leimkuehler, chairman of the Committee on Public Information of the St. Louis Chapter, tells how to make any architectural exhibition greatly extend its service to the architect and to the public. "Among other publicity activities during the summer," said Mr. Leimkuehler, "we have rotated the exhibition of the St. Louis Chapter after it was exhibited at the New York Architectural League last spring. It has been hung at the Art Museum, the Public Library, and is now at Washington University."

Russell G. Creviston, President of the Producers' Council, writes: "Under separate cover we are sending a framed copy of your leaflet 'The Value of the Architect,' so you may know how this message is being displayed in our one hundred odd show rooms. The reaction has been so favorable, particularly on the part of our own organization, that several of our branches have suggested that we prepare this statement in the form of a small circular for distribution . . ."

Many Institute Chapters are interested in "group advertising"—telling the public through the press something about the services of the architect. To facilitate this, a well-known

COMFORT

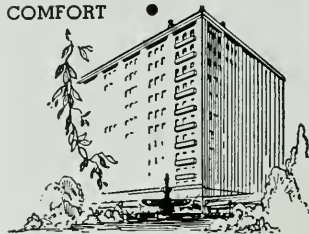

New HOTEL CLARK

in Downtown
LOS ANGELES

Convenience is another offering of this hotel. Whether on business or pleasure bent, the Hotel Clark makes an ideal "base of operations," as well as a restful "billet" at the end of the day's "campaign." Good Food, naturally. And moderate charges, as well as for room accommodations, give final significance to assuring word — COMFORT.

Single from \$2.50

Double from \$3.50

ROOMS
555
BATHS

Fifth and Hill

P. G. B. MORRIS, *Manager*

ANDERSON & RINGROSE

General Contractors

320 Market Street, San Francisco

Phone GARfield 2245

HIGH GRADE MILLWORK
AND INTERIOR FINISH
SASH AND DOORS

LANNOM BROS. MFG. CO.

FIFTH AND MAGNOLIA STREETS
OAKLAND, CALIFORNIA

Telephone: TEmplebar 3663

MULLEN MFG. COMPANY

BANK, STORE AND OFFICE
FIXTURES—CABINET WORK
OF GUARANTEED QUALITY
CHURCH SEATING

Office and Factory:
60-80 RAUSCH ST., Bet. 7th and 8th Sts.
San Francisco
Telephone UNDERhill 5815

G. P. W. JENSEN & SON

Building Construction

320 Market Street, San Francisco
Phone: GARfield 2444

DINWIDDIE CONSTRUCTION COMPANY

•
BUILDERS
•

CROCKER BUILDING
SAN FRANCISCO

Carl T. Doell Co.

*Plumbing
Heating*

Plumbing Contractor
Veterans Memorial Building
Oakland

467 21ST STREET
OAKLAND
Telephone GLencourt 8246

advertising firm has prepared a publicity program consisting of a series of twelve short, well-written statements designed for publication. This series, according to the Octagon, will soon be available.

MEXICAN ARCHITECTS

Dear Editor:

I am sending you an up-to-date mailing list of architects and engineers interested in residential and commercial building throughout the Republic of Mexico.

According to the list there are not many architects. This is an accidental error of long standing. Many Mexican architects resent being called engineers despite the fact that it is an old custom among the workmen to call anybody on a job that appears at all official an engineer. Accordingly there are bound to be several "engineers" on the list that might more honestly be called "building chislers," "sub-contract brokers," etc.

But, as lists go, there are some real hombres on it. Many construct all their own work and no few are outstanding.

So-called "copy books" are rare in Mexico. In fact the lack of them is one reason the "Pack Box" style became so popular with many "engineers." Not an isolated case by any means is the history of Pepe Como Si Llama, who, although born on the Texas side of the Rio Grande, found it practical to join up with the Mexico City boom in the early thirties, when liquidating his many debts became a problem not even a practical carpenter could solve. He rode into the city "first class" on funds obtained by the simple expedient of pawning his furniture, upon which not an installment had ever been paid. Well knowing the skill and labor required to cut a pretty Spanish caper, Engineer Pepe could now apply his Texas English to immediate profit. . . . With plenty of tracing paper and pencils, it was no time at all until Pepe was regarded in some quarters as one of the most amazing engineers ever to be educated in the States. And like many another, Pepe's library simply consisted of a pile of well copied American architectural magazines.

At least it was about such matters that I thought your journal might catch on in Mexico for wherever I have discussed California architecture, much interest has been manifested.

Yours very truly,
L. S. SANDERSON Architect.

Laredo Texas,
September 24, 1938.

Louis C. Dunn, Inc.

GENERAL
CONTRACTORS

Monadnock Building
San Francisco

Phone: DOuglas 4632

Empire Construction Co., Ltd.

Builders



RUSS BUILDING
SAN FRANCISCO
SUtter 2989

Smith

Lumber Company
WHOLESALE - JOBBING - RETAIL
FACTORY AND BUILDING LUMBER
PLYWOODS - ROOFING

DISTRIBUTING YARDS

San Francisco	Oakland
•	19th Ave. &
4th & Channel	Estuary
Market 0103	FRuitvale 3174

YOUR INQUIRIES SOLICITED

JOSEPH MUSTO SONS-KEENAN COMPANY

MARBLE
and
ONYX

535 NORTH POINT STREET
SAN FRANCISCO
1801 S. SOTO STREET
LOS ANGELES

ABBOT A. HANKS, INC.
Engineers & Chemists

INSPECTING — TESTING — CONSULTING
 CONCRETE • STEEL • MATERIALS
 CHEMICAL AND TESTING
 LABORATORIES
 • RESEARCH AND INVESTIGATION •

TESTS OF STRUCTURAL MATERIALS
 DESIGN OF CONCRETE MIXES
 SHOP AND ERECTION INSPECTION OF
 STRUCTURES AND EQUIPMENT
 INVESTIGATION OF STRUCTURES
 AND MATERIALS
 TESTS AND INVESTIGATION OF
 FOUNDATION SOILS
 FIRE RESISTANCE AND INSULATION
 TESTS

624 Sacramento Street, San Francisco

Phone GARfield 1164

Hunter & Hudson

Consulting Engineers

DESIGNERS OF HEATING
 AIR CONDITIONING
 VENTILATING AND WIRING
 SYSTEMS, MECHANICAL
 AND ELECTRICAL EQUIP-
 MENT OF BUILDINGS

41 SUTTER STREET
 ROOM 710
 San Francisco California

Another Monument

to
DUNNE PRIMER SEALER

and
DUNNE SATIN WALL

The Best For
Looks - Protection - Economy

Inspect the
 Alameda County Court House

FRANK W. DUNNE CO.
 41st and Linden Sts. Oakland, Calif.
 MAKERS OF GOOD PAINT

VAUGHN - G. E. WITT Co.

Manufacturers and Distributors

Pump Governors	Oil Heaters
Safety Pump Governors	Relief Valves
Automatic Gas Regulating Valves	Oil Burner Governors
Gas Burning Equipment	Oil Burners
Vacuum Pump Governors	Oil Pumping Sets
Vacuum Regulating Valves	Oil Valves
Continuous Flow Steam Traps	Oil and Steam Strainers
Thermostats	Duplex Oil Pumps
Reducing Valves	Rotary Oil Pumps
	Boiler Feed Pumps
	Water Heaters
	Boiler Feed-Water Regulators

4224-28 Hollis St., Emeryville, Oakland

THE HERMANN SAFE CO.

MANUFACTURERS AND DEALERS

OF
 FIRE AND BURGLAR PROOF
 SAFES AND VAULTS, SAFE-
 DEPOSIT BOXES, ETC.

200 HOWARD STREET
 SAN FRANCISCO
 GARfield 3041 - 3042

REPUBLIC STEEL CORPORATION



Manufacturers of

ENDURO Stainless Steel; TON-CAN Copper Molybdenum Iron Sheets and Pipe; and Steel Pipe, Sheets and Reinforcing Bar for every building purpose.

Write for information

Rialto Building, San Francisco, Calif.
 Edison Building, Los Angeles, Calif.
 White-Henry-Stuart Bldg., Seattle, Wash.

VERMONT MARBLE COMPANY

Producers and Finishers
 of

Domestic and Imported
 Marbles

San Francisco
 Los Angeles
 and
 Tacoma, Wash.

Robert W. Hunt Company
 ENGINEERS

Inspection - Tests - Consultation
 Schools and Other Structures
 Are Built as Designed

*When Construction Materials are
 Inspected at point of Manufacture
 and during Erection by*

ROBERT W. HUNT COMPANY

*Cement, Concrete, Chemical, Metallurgical,
 X-Ray and Physical Laboratories*

Chicago - New York - Pittsburgh
 Los Angeles - All Large Cities
 San Francisco, 251 Kearny Street

JOHN CASSARETTO

—Since 1886—And Still Active—

Building Materials

READY MIX CONCRETE
 ROCK - SAND - GRAVEL - LIME
 CEMENT - PLASTER - MORTAR
 METAL LATH - WOOD LATH
 STUCCO - WIRE NETTING

Service Unexcelled

Bunkers
 Sixth and Channel, San Francisco
 Phones: GARfield 3176, GARfield 3177

1938

**BUY CHRISTMAS SEALS
 PROTECT YOUR HOME
 FROM TUBERCULOSIS**

**FINE WATER COLORS
 AND PAPERS
 FOR ARCHITECTURAL
 RENDERINGS**

**H. S. CROCKER
 COMPANY, Inc.**

720 MISSION STREET
 MARKET STREET AT SECOND
 SAN FRANCISCO

**THE TORMEY
 COMPANY**

GENERAL PAINTERS
 AND DECORATORS

Phone UNderhill 1913

563 FULTON STREET
 San Francisco

INDEX TO ARTICLES AND ILLUSTRATIONS

The Architect and Engineer

1938.

A

Accounting for Architects, Poem (I. F. Morrow)	Aug. 50
Adobe Construction, F.H.A. Requirements	May 51
A.I.A. Convention	June 55
A.I.A., What Is It Doing for Me (Francis P. Sullivan)	Aug. 35
Air Conditioning Research Developments	Feb. 43
Alden, Chas. A., Guest Editor	Mar. 13
Allison & Allison, Work of, (Irving F. Morrow)	May 13
Along the Mississippi (H. M. Michelsen)	Aug. 25
Architect and Client Have Like Ideas for Home (J. H. Vogel)	May 39
Architect and His Shortcomings (Fredk. Hamilton)	June 35
Architect, Is He Losing His Independence (R. Neutra)	Oct. 49
Architect and the Housing Act (Nathan Strauss)	Aug. 62
Architects, More Business for (Chester H. Miller)	Oct. 43
Architects' Fees for Federal Work	Aug. 63
Architectural Examiner, State Board (A. M. Edelman)	Oct. 51
Architectural Legislation	Mar. 63
Architectural Practice in California, Rulings On	Nov. 53
Architectural Profession, Unification of (H. H. Michelsen)	June 21
Architectural Standards	Jan. 57
Architectural Trends in Washington (C. H. Alden)	Mar. 13
Architecture, Early American, Revealed by Diary	Aug. 24
Architecture, A Profession (E. J. DiRienzo)	Aug. 33
Apartments, Regent, Portland (Harry A. Herzog)	July 41

B

Backstage in Europe's Industries (F. R. Letchfield)	Aug. 64
Bank, U. S. Natl. of Portland, Klamath Falls Branch, (Sutton, Whitney & Aandahl)	July 42
Basalt Light Weight Reinforced Concrete Construction	Jan. 40
Bids, Opening of Public, Questionnaire	Sept. 54
Bolts, Rivet Head, in Old Concrete	Feb. 55
Bridge, Arroyo Drive, L. A.	Feb. 48
Bridge, Red Bluff, Sacramento River	May 45
Bridge, Dunsuir	May 46
Bridge, Yager Creek, Humboldt	May 47
Bridges, Narrow, Truss Failure of (F. W. Panhorst)	May 45
Broadcasting Studio, Columbia, Hollywood (Wm. L. Lecaze)	Sept. 14
Bruss, Arthur, Jr., A Fair Architect	Jan. 46
Building, Is It on the Upgrade (Fredk. H. Meyer)	Jan. 46
Building Recovery Described by A.I.A.	May 37
Building Code Requirements	June 63
Building, Eighty-five Per Cent Minus Architectural Service	July 62
Building Costs Up	Oct. 62
Building Laws, State, Congress Discusses	Oct. 63
Building Industry, Coordination of (Chas. H. Cadman)	Dec. 33

C

Cement Gun Construction in Simplified Form	Jan. 44
Church, Catholic, Medical Lake, Wn., (Jno. W. Maloney)	Mar. 24
Church, St. John the Evangelist, Spokane (Whitehouse & Price)	Mar. 29
Church, First Congregational, L. A. (Allison & Allison)	May 32, 34, 44
Church, St. Geo. Episcopal, Roxburg, Ore. (Sutton, Whitney & Aandahl)	July 34
Church, St. Mary's, Eugene (Sutton, Whitney & Aandahl)	July 34
Church, First Christ Scientist, Beverly Hills (P. L. Lewis)	Aug. 38
Club, Town, Portland (Johnson, Wallwork & Dukehart)	July 23
Club, Hollywood Turf, (Stiles O. Clement)	Aug. 28
Club, Cabana, Sta Barbara (Gardner A. Dailey)	Oct. 46
Competitive Designs for Structural Clay House	Jan. 47
Concrete Houses (Amos H. Potts)	Jan. 17
Concrete Industries to Meet in Chicago	Jan. 61
Concrete, Problems of Connecting New with Old	Mar. 51
Concrete House Design	Apr. 63
Concrete, Specifications for Structural (Jos. A. Kitts)	Oct. 53
Concrete House, Double Walled (F. H. Slocombe)	Nov. 5
Contest for Home Design for S. F. Fair	Feb. 57
Co-ordination (Harris C. Allen)	Oct. 52
Convention, A.I.A., New Orleans, April, 1938	Mar. 54
Convention, State Assn. of Calif. Archts. Programme	Oct. 18
Convention, Structural Engineers	Nov. 67
Curb, Reflecting, New Type (F. J. Grumm)	Feb. 45

D

Dam, Boulder, Revenues	Feb. 70
Dam, Bids for Shasta	May 64
Dam, Shasta	Oct. 72
Dam, Shasta, Activity	Nov. 72
Dynamic Shears in a Sixteen Story Model	May 59

E

Earthquake Resistance and Rigidity	Mar. 56
Earthquake, Study of Artificial	July 58
Engineers, Heating & Ventilating, 44th Annual Meet	Feb. 58
Engineers, Annual Outing at Saratoga	June 57
Employment, Architects Solution of (Jos. L. Stewart)	Apr. 43
Exhibition, Architectural, N. Calif. Chapter A.I.A.	Oct. 16
Exposition, G. G., Federal Bld. (T. L. Pfeueger)	Mar. 32
Exposition, G. G., Design and Construction (J. J. Gould)	Apr. 45
Exposition, G. G., Conception by Night (C. K. Bonestell)	June 50

Exposition, G. G., Engineering Problems	Aug. 57
Exposition, G. G., Chinese Architecture (Mark Daniels)	Sept. 41
Exposition, G. G., Gas Industry Bldg.)	Oct. 56

F

Factory Bldg., Owens Illinois Glass, Oakland	June 25
Factory Bldg., Owens Illinois Glass, La. (Albert Roller)	Aug. 23
Factory Bld., Spreckels Sugar, Woodland (Geo. W. Kelham, et al)	June 30
Factory Bld., Janzen Knitting Mills, Portland (Richard Sundleaf)	July 32
Factory Bldg., Truck & Tractor Co., Inc., Aberdeen (Clarence W. George)	Aug. 4
Fair Trade Practices (Pierson M. Hall)	Mar. 60
Flood Control Needed (Edw. Hyatt)	May 49
Flood Area in California, Survey by U. S.	May 66

G

Garden, An Old Fashioned (Bernice Ashdown)	Aug. 6
Garden, Ground Covers (Bernice Ashdown)	June 5
Garden, How's Your Lawn (Bernice Ashdown)	Oct. 8
Garden, Mrs. T. B. Wilcox, Portland	July 26
Garden, Mrs. John B. Yeon, Portland	July 26
Gymnasium, Plastering Specifications for	Nov. 62

H

Highway Building in California (Ernest McGaffey)	Mar. 43
Highways, Roosevelt	Mar. 44
Highways, Construction of Mountain (Ernest McGaffey)	Aug. 45
Highlights (H. M. Michelsen)	Oct. 31
Home, Los Cost, New Approach Needed	Feb. 62
Home Financing, F.H.A., Insured Mortgage System (C. A. West)	Mar. 33
Home Builders, Architectural Advice to	Apr. 37
Home Building, Simplification of Construction (W. H. Lowe)	Apr. 41
Home Decoration, Trends In (Mary D. Gillis)	June 41
Home Owning, Outlay of	June 62
Home Ownership, Better and Safer (Jno. H. Fahey)	Aug. 41
Home Model, Blue Ridge, Seattle (T. F. Bellamy)	Aug. 31
Homes, Ante Bellum (P. J. Rinderle)	Dec. 43
Honor Awards, A.I.A.	Oct. 20-29
Hospital, Tuberculosis, Portland (Lawrence Holford & Allyn)	July 29
Hospital, Good Samaritan, Portland (Sutton, Whitney & Aandahl)	July 33
Hospital, Western State, Fort Steilacoom, Wn. (Heath, Gove & Ball)	Mar. 28
Hotel Empire, S. F. Cocktail Bar (Hertzka & Knowles)	Apr. 20
Hotel, Timberline Lodge, Mt. Hood (Gilbert Stanley)	July 27
Hotel Fairmont, Cocktail Bar	Oct. 19
Hotel Ahwahnee, Yosemite, Dining Room (Spencer, Blanchard & Maher)	Dec. 15-17
Hotel Ski Lodge, Badger Pass (Spencer, Blanchard & Maher)	Dec. 18-19
Hotel, Mariposa Lodge (Spencer, Blanchard & Maher)	Dec. 21-22
Hotel, Gate Lodge, Point Lobos	Dec. 21-22
House, Number, Concrete	Jan. 44
House, Small, Stimulate the Market (W. D. M. Allan)	Feb. 27
House, Small, Expert Advice Needed	Feb. 28
Houses, Adobe, in Fresno County, Demolished by Flood	Apr. 50
Housing for Ideas (Harris C. Allen)	Feb. 31
Housing, New F.H.A. Program	Mar. 34
Housing, Documents Architects Should Have	Mar. 56
Housing Shortage in California (E. L. Snyder)	Apr. 25
Housing Bureau Models-Richmond Garden Project (E. L. Snyder)	Apr. 24-9
Housing, Multi Family-New Program (C. A. West)	May 35
Housing, New Conditions in	Aug. 54
Housing Project, San Gabriel (J. Ferguson)	Nov. 41
Housing, Trouble with Modern	Nov. 69

I

Index for 1937	Jan. 81
Index for 1938	Dec. 81
Industrial Building Design, New Note-Owens, Ill., Glass	June 25
Insulation, Analysis of Three Types of House (J. R. VonSternberg)	Dec. 37
Interiors	Oct. 30

L

Legislation to Eliminate State Bureaucracy (Lester Hibbard)	Oct. 39
Library Architecture, Recent Trends (Carl B. Roden)	July 45
Lighting, Outdoor, for Yuletide (Agnes M. Barrell)	Dec. 39

K

Kitchen, Tile Lends Color to	Aug. 4
------------------------------	--------

M

"Men in Smocks"	Apr. 31
Modernization by Owners and Builders	Feb. 39

Modernization Credit Plan (C. A. West)	July 35
Mortuary, Hennessy, Goetsch & McGee, Portland (Barrett & Logan)	July 30
Mortuary, Finley's, Portland (A. E. Doyle)	July 35
Museum, Art, Portland	July 36

O

Office Bldg., Natl. Broadcasting Studio, Hollywood (O. B. Hanson)	Feb. 38
Office Bldg., Farmers Auto Ins. Exchange, L. A. (Walker & Eisen)	Feb. 30
Office Bldg., Telephone Bldg., Tacoma (Bebb & Gould)	Mar. 23
Office Bldg., Columbia Steel Co., L. A.	Mar. 42
Office Bldg., Central Tower, S. F. (Albarr Roller)	Aug. 14-22
Office Bldg., Central Tower, A New Note in S. F. Skyline	Aug. 15
Office Bldg., Ins. Co. of N. A. (Harry A. Thomson)	Aug. 30
Office Bldg., Dean & Witter Co., Westwood (A. G. Siple)	Aug. 37
Oregon Architects, What They Have Been Doing (Glenn Stanton)	July 13

P

Parable on Style (Poem) (Irving F. Morrow)	July 49
Plywood Becomes Influence in Design (Jos. Weston)	Sept. 15
Plywood Finishing, Douglas Fir (G. N. Arneson)	Sept. 25
Plywood in Engineering & Construction (N. S. Parkins)	Sept. 35
Plywood Paneling, Portfolio (Carl F. Gould)	Sept. 45
Prefabricated Homes and Community Development	Mar. 61
Prefabricated in Sweden	Mar. 69
Public Building, Louisiana State Capitol	Feb. 14
Public Building, Post Office, Sacramento (Starks & Flanders)	Feb. 30
Public Building, Calif. State Prison, Proposed, San Bernardino (Walker & Esian)	Feb. 38
Public Building, Vista House, Mt. Spokane (H. C. Bertelson)	Mar. 18
Public Building, Community Center, Lakewood, Wn. (S. E. Nelson)	Mar. 20
Public Building, Hospital for Insane, Wn. (Health-Gove and Bell)	Mar. 28
Public Building, U. S. Post Office, Merced (Allison & Allison)	May 31
Public Building, U. S. Post Office, Redding (Albarr Roller)	June 19
Public Building, U. S. Post Office (Homer Hadley)	June 39
Public Building, City Hall, Canby, Ore. (Jones & Marsh)	July 31
Public Building, Armory, Klamath Falls (Howard Perrin)	July 31
Public Building, Civic Auditorium, Sta Cruz (Mark Daniels)	Aug. 40
Public Building, New Philharmonic, L. A.	Sept. 17, Dec. 32

R

Restaurant, Wayside, Seattle (V. S. Stimson)	Mar. 19
Rumpus Room, New York	Mar. 39
Running Fire (Mark Daniels) 3 July; 2 Aug.; 2 Sept.; 2 Oct.; 2 Nov.; 1 Dec.	

Residences:

Adams, H. L., Chico (H. H. Gutterson)	Dec. 27-8
Adams, Frank, Palos Verdes (Las. R. Friend)	Jan. 24
Atkinson, Hewitt P., Orinda (Jas. H. Anderson)	Jan. 27
Arneson, Mrs. Robt., Lake Oswego (Glenn Stanton)	July 24
Babler, Lloyd, Portland (Johnston & Brookman)	July 13
Bailey, Dr. Paul, Portland (Johnson, Walkow & Dukehart)	July 23
Beach House in Northern California (Wm. Wurster)	Oct. 47
Beckwith, S. Y., San Rafael (R. L. Stringham, et al)	Oct. 47
Bliss, Mrs., Sta Maria (L. N. Crawford)	May 36
Bliss, Mrs., Sta Maria (L. N. Crawford)	May 38
Biddle, Spencer, Vancouver (Ernest F. Tucker)	July 21
Bradley, A. R., Albany, Ore.	Sept. 34
Burns, Bob, Bel Air (H. Roy Kelley)	Jan. 20
Clapp, Jas., Pasadena (W. Risley)	Oct. 26
Clark, Harrison, Tacoma (Silas E. Nelson)	Sept. 27
Competitive Designs in Clay Houses	Jan. 47
Concrete Houses (Amos H. Petts)	Jan. 27
Concrete Model (Theo. Jacobs)	Jan. 27
Concrete Residence at Palm Springs (S. H. Willard)	Jan. 30
Concrete, Low Cost, Atherton (Mark Daniels)	Jan. 35
Cutler, F. W., Oregon (Morgan & Hartford)	July 18
Deichmann, O. A., San Mateo	Jan. 38
De Naffe, F. M., Portland (Roi L. Morin)	July 22
Ector, J. J., Yakima (Wm. J. Bain)	Mar. 16
Eloesser, Herbert, St. Helena	Jan. 39
Friend, Jas. R., Rolling Hills (Same)	Jan. 32
Fuller, Dr. B. A., Hollywood (R. C. Flewelling)	Sept. 18
Galli-Curci, Westwood (Wallace Neff)	Oct. 29
Gregg, John D., Arcadia (Garrett Van Pelt)	Jan. 26
Guira, O. G., Colton (W. L. Culver, Jr.)	Jan. 37
Halliburton, Richard, Laguna Beach (Alex. Selvy)	Jan. 22
Hall, J. W., Fresno	Jan. 42
Hoffman, Earl L., Los Angeles (Leo F. Bachman)	Sept. 29
Holman, Mrs. John, San Marino (H. Roy Kelley)	May 42
Ilsey, Phillip, Brantwood (Jno. Byers)	Jan. 28
Irvine, Jas., Altadena (H. Roy Kelley)	Oct. 20
Irving, H. A., Atherton (H. H. Gutterson)	Dec. 30
Kiernan, Frank, Jr., Portland (Roi L. Morin)	July 19
Jackson, Jos. Henry, Berkeley (Michael Goodman)	Sept. 20
Kistner, Dr. Frank B., Portland (Wade Pipes)	July 15
Lauder, A. I., Seattle (Joshua H. Vogel)	May 39
Loveless, Arthur, Portland (Same)	May 15
Lucas, Orton, Orinda (F. L. Confer)	Oct. 42
Maddock, Edw., San Marino (H. Roy Kelley)	Apr. 34
Marischal, J. J., Spokane (G. A. Pehrson)	Jan. 36
Marston, Otis R., Berkeley (Eldridge T. Spencer)	Dec. 23
Meier, Frank, Oregon (Johnston & Brookman)	July 12
Miller, Sefton, L. A. (Chas. O. Matcham)	Jan. 31
Millikan, Chas. E., Glendale (A. R. Hutchison)	May 6
Mitchell, Robt. B., Piedmont (Miller & Warnecke)	Oct. 44
McLean, Dr. E. H., Oregon	Oct. 4
Newbegin, Wade, Portland (Harold W. Doty)	July 28
Parsons, H. S., San Marino (Palmer Sabin)	Oct. 20
Pendell, F. E., Los Angeles	Jan. 45
Physician's, Los Angeles (Heth Wharton)	Jan. 29
Pilinsky, Oakland (Earl R. MacDonald)	Feb. 14
Platt, Jas. D., Oregon (Roi L. Morin)	Aug. 10
Pringle, R. J., Bel Air (H. Roy Kelley)	Jan. 16
Ranch House, Lafayette (J. E. Dinwiddie)	June 34
Reinke, Irvin S., Portland (A. W. Hilgers)	July 16
Rodakiewicz, H., Los Angeles (R. M. Schindler)	Aug. 10
Rodgers, Thos. F., Hollywood (A. L. Herberger)	Aug. 16
Rosenblatt, Dr. M., Portland (Johnston & Brookman)	July 14

Sammons, M. J., Portland (Johnston & Brookman)	July 14
Smiley, Arthur, Bel Air (Roland E. Coate)	Oct. 22
Spaulding, Sumner, Beverly Hills (Same)	Oct. 25
Stimson, C. W., Seattle (Edwin J. Ivey)	Mar. 14
Swanson, R. A., Ore. (Lloyd Wright)	Sept. 34
Taylor, Edgar, Berkeley (Michael Goodman)	Mar. 17
Thompson, Kirk, Spokane (G. A. Pehrson)	Apr. 30
Topfll, Major, Los Angeles (H. Roy Kelley)	Apr. 30
Tryon, Prof., Berkeley (Michael Goodman)	Sept. 19
Walter, David, Arcadia (Marston & Maybury)	Oct. 24
Walls, Dr. Richmond, Portland (Wade Pipes)	July 14
Weberhauser, John P., Amer. Lake, Wn. (Lea Pearson)	Mar. 13
Winterburn, J. C., Menlo (B. D. Clark)	Oct. 48

S

SCHOOLS:

McClatchey High, Sacramento (Starks & Flanders)	Feb. 31-7
State College of Washington (Stanley A. Smith)	Mar. Fnt.
Bellingham High, Wn. (Whitehouse & Price)	Mar. 30
Arlington High, Wn. (Wm. Mallis)	Mar. 31
El Carito, Los Angeles (Chas. M. Hutchison)	Mar. 40
Cherry Hill College, Ontario (Allison & Allison)	May 12-24-5
Francis E. Willard Junior High, Sta Ana (Allison & Allison)	May 18
Central Elementary, Huntington Beach (Allison & Allison)	May 19
Van Nuys High (Allison & Allison)	May 20-1
Santa Ana (Allison & Allison)	May 22-3
Pomona College, Pomona (Allison & Allison)	May 26
Laguna Beach Elementary (Allison & Allison)	May 28
Los Angeles Proposed Jr. High (Allison & Allison)	May 30
Ruth School, El Monte (G. Stanley Wilson)	May 31
All Saints, Portland (Francis B. Jacobberger)	July 38
Irrington, Portland (Geo. H. Jones)	July 38
Salem Senior High (Knighton & Howell)	July 39
Sierra Madre Elementary (Marsh, Smith & Powell)	Nov. 14
South Pasadena High (Marsh, Smith & Powell)	Nov. 15
Hollywood High (Marsh, Smith & Powell)	Nov. 22-5
Lyndon Junior High (Marsh, Smith & Powell)	Nov. 24
Newport Harbor High (Marsh, Smith & Powell)	Nov. 28-31
Henry E. Huntington, San Marino (Marsh, Smith & Powell)	Nov. 32
John Adams Jr. High, Sta Monica (Marsh, Smith & Powell)	Nov. 34
Madison, Sta Monica (Marsh, Smith & Powell)	Nov. 36
Sunshine, San Francisco (Marsh, Smith & Powell)	Nov. 37
Sunshine, San Francisco, for Physically Handicapped	Nov. 39
School Classroom Lighting	Jan. 70
School Design, Progress In (Marsh, Smith & Powell)	Nov. 15
School Design Trends (Herbert J. Powell)	Nov. 23
Store Building, Remodeled, Seattle (J. L. Holmes)	Mar. 24
Store Building, Passemiers Bootery, Tacoma (McClelland & Jones)	Mar. 25
Store Building, Bests Apparel Shop, Seattle (McClelland & Jones)	Mar. 25
Store Building, Rosenberg Dept., Sta. Rosa (Hertzka & Knowles)	Apr. 15
Store Building, Rosenberg Dept. (F. W. Jones)	Apr. 15
Store Building, Ernest Ingold, S. F. (J. E. Dinwiddie)	June 13-19
Store Building, Gumberts, Portland (Lawrence, Holford Allyn & Bean)	July 29
Store Building, Fifth Ave. Shop, Portland (A. E. Doyle)	July 37
Store Building, Stone-Mergulsi, Portland (A. L. Herzog)	July 40
Store Building, Burnett Bros., Portland (A. L. Herzog)	July 40
Store Building, Dady Bldg., Portland (A. L. Herzog)	July 41
Store Building, Gilberds, Oakland (F. W. Confer)	Nov. 40
State Assn. of California Architects, Why	Apr. 59
State Assn. of California Architects, Origin of (J. J. Donovan)	Oct. 35
State Assn. of California Architects, Relation to A.I.A. (Robt. H. Orr)	Oct. 37
Swimming Pool, F. C. Banner, Orinda (Wm. Wurster)	Jan. 33
Swimming Pool, Frauner Residence (Jas. H. Mitchell)	Oct. 38
Stucco, Use of Cheap Waterproofing Products (Wm. C. Rea)	Mar. 41
Stuck Plan Book, I Am a S. Sanderson	June 27
Service Station, Portland (Clayton S. Clausen)	Sept. 4
Stairway, Spiral, Detail (Garnder Dailey)	Oct. 16
Steel Minded Public (V. G. Iden)	Nov. 45
Street Plan for San Francisco (Geo. S. Hill)	Nov. 48

T

Telescope, Mr. Palomar	Apr. 65
Terminal, Colman Ferry, Seattle (Arthur Loveless)	Mar. 31
Terminal, Bay Bridge	June 43
Terminal, Sta Fe (H. L. Gilman)	Aug. 32
Temple of Jehol, Chicago, Coming Down	May 65
Through A Monacle (Harry Sanders, Jr.)	July 43
Tunnel, Broadway, Joining Two N. Cal. Counties	Jan. 53

U

Uncompleted Project, Have You One?	Feb. 12
Unemployment Drop Explained	Feb. 41
University of Oregon Library (Lawrence, Holford, et al)	July 28
University, Willamette, Salem (A. E. Doyle)	July 37
University of Washington, Research Laboratory (B. L. Grondal)	Sept. 39
University of Washington, Chemistry Bldg. (F. A. Nuramoure)	Mar. 21
University of Washington, Law Building (A. H. Albertson)	Mar. 22
University of Calif. at Los Angeles (Allison & Allison)	May 14
Unification Most Desirable (A. J. Evers)	Oct. 45

W

Window Conditioning (Earl Aiken)	Nov. 51
World's Fair Builders, Arthur Brown, Jr.	Jan. 54
World's Fair Builders, Wm. P. Day	Mar. 38
World's Fair Builders, T. L. Pflueger	May 48
World's Fair Builders, Ernest E. Weihe	June 47
World's Fair Builders, Wm. G. Merchant	July 48
World's Fair Builders, Lewis P. Hobart	Aug. 48
World's Fair Builders, Edw. L. Frick	Nov. 4
World's Fair Builders, J. E. Stanton	Dec. 47

Z

Zoo, Fleishacker, S. F. (Lewis P. Hobart)	Feb. 16-25
---	------------

THE
ARCHITECT
AND
ENGINEER

JANUARY 1939

San Francisco Bay Bridge Terminal

2800 Tons of Steel

IN SAN FRANCISCO'S NEW BAY BRIDGE TERMINAL

WITH these new terminal facilities in operation, smooth-running, 10-car electric trains will operate on 63-second headway schedules across the San Francisco Bay Bridge, between metropolitan Oakland and San Francisco.

Through this terminal, trains running directly from Alameda, Berkeley and Oakland will bring many of the daily commuters within walking distance of their destinations in San Francisco, at an estimated saving to passengers of 15 minutes per trip.

Thus, the completion of this terminal marks a new era in San Francisco's rapid transit program and we of Columbia Steel Company are proud to have played a part in its construction. Our participation involves the fabrication and erection of all structural steel both in the terminal and approaches. This includes the deck plate-girder and beam construction of the viaduct loop, with overpasses at eight street crossings; mezzanine, track floor and roof framing for the terminal building, 165 ft. wide and 700 ft. long; roof steel for garage, and the steel catenary bridges for electric power lines.

We cite this typical construction as criterion of our ability to serve your needs in steel. Our furnaces, steel mills and foundries, at Pittsburgh, Contra Costa County and at Torrance, Los Angeles County, our wire rope and fence factory at San Francisco are western institutions, close at hand to render you steel service second to none.

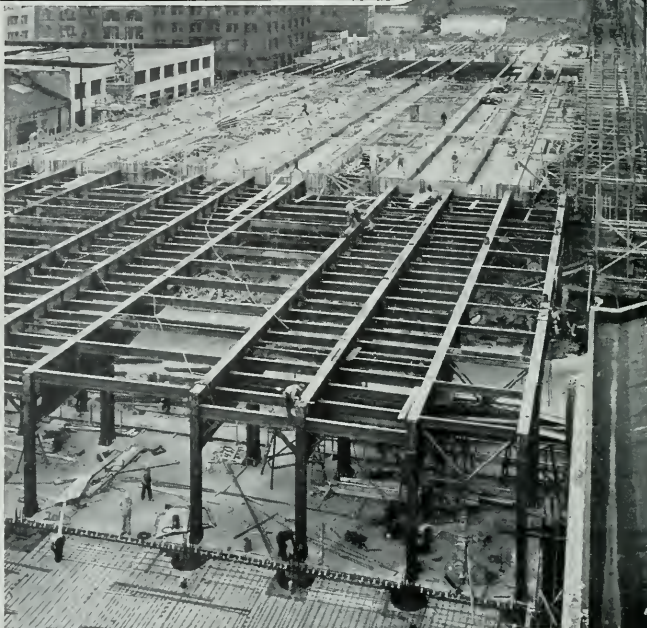

New Bay Bridge Terminal under construction. Built by the State Department of Public Works, Earl Lee Kelly, Director; under the jurisdiction of the California Toll Bridge Authority, Gov. Frank F. Merriam, Chairman, C. H. Purcell, Chief Engineer, General Contractor for Structural Steel—Columbia Steel Co.

Track Floor of the new Bay Bridge Terminal showing over-head roof structure in which minimum depth of steel framing and clean-cut aesthetic treatment is obtained by using primary members of patented Beam-Arch construction.

COLUMBIA STEEL COMPANY

San Francisco · Los Angeles · Portland · Seattle · Salt Lake City



Pacific Coast Distributor for

American Bridge Company · American Steel & Wire Company · Carnegie-Illinois Steel Corporation
National Tube Company · Tennessee Coal, Iron & Railroad Company

UNITED STATES STEEL

RUNNING FIRE

by

MARK DANIELS, A.I.A.

Fire-Proofing The Hod Carriers

The daily press has announced that five hod carriers have passed their civil service examinations. I have not seen the questions in these examinations, so am reduced to speculation as to what they might be.—Somewhat along the following, perhaps.

How high must you climb before the brick you drop from the hod onto the bean of the inspector below will knock him out?

What is the least number of bricks that can be carried in a hod?

What is the least number of hods?

Can you carry a hod upside down?

But a broader scope and deeper meaning may be sensed in this broadening of the civil service. Perhaps it is the start of a series of civil service examinations for mayors, governors, senators and even presidents. In certain instances of the foregoing category civil service might be superfluous for their jobs seem already to be in perpetuity.

★ ★ ★

Pulpit Topics

Roars of indignation rose heavenward from many pulpits when Billy Sunday announced some of his more pungent sermon topics early in the century. To Hell with the Devil, Sock the Devil in the Eye, or some such phrases were not infrequently the subjects of his sermons. The clergy said it was undignified. They felt that such language brought preaching the gospel down to the level of slum jargon, which may have been true, although it brought the very people who most needed religion to hear what it was all about. Yet with all his declaiming and ranting I never heard of Billy Sunday prostituting his evangelizing to advertising a commercial enterprise or commodity.

Now we read in the dailies that the subject of a prelate's sermon will be "Shine for '39." Perhaps it was inspired by the good biblical

phrase, "Let thy light so shine," but the phrase has been all but copyrighted as an advertising slogan for the Exposition, and the announcement that it will be used as the subject of a Sunday sermon lowers the pulpit to the level of an out and out ballyhoo stand. Perhaps it will not be long before cathedral chimes will call us to hear the Reverend Noddleknob deliver a burning and inspired discourse on the "The Hemmingway, Nu-way, no-sway Brassiere." When that time comes we will need all the forgotten prayers of the world.

★ ★ ★

Three Up and Four to Go

It was with considerable pleasure that I read, a few days ago, that the United States had again rebuked Japan. That's the stuff! Don't let any nation think it can walk over us with impunity. Rebuke 'em. That's the stuff. Rebuke 'em.

I went home that night feeling pretty chesty. These foreigners can't get fresh with us. We just won't stand for it. But in the morning my chest collapsed below normal when I read in the paper that Japan had rebuked us right back again. My coffee turned bitter, my butter rancid.

All day long this worried me and I decided to go back over the newspaper files to see how things really stood between us and the Japs. I am glad I did this for by midnight I checked off the list and found we were still three rebukes up on them.

★ ★ ★

Safety First

Some thirty-odd years ago I worked under Mr. W. W. Slater, Signal Engineer for the Southern Pacific Railway, and his assistant Mr. Young, on the mechanical interlocking towers that controlled signals and switches on what we then called "Long Wharf." We thought we were about the last word in signal and train control in terminals.

A few days ago, Mr. Harmon Wickson, who is the head of the signal and control system for the Key Route Company, took me over

to see a 1939 method of signal and train control for the bridge terminals of the Trans-bay transportation system. (See photo on page 32.) What I saw made the work we had been so proud of 35 years ago look like a boy's contrivance with blocks and pieces of string. This new system is built by the General Railway Signal Company of Rochester, New York. There is a board before the operator's desk on which is shown every signal and switch point on the terminal. The entire apparatus occupies about the space of an office desk, and is operated by push buttons and light switch levers of about the same design and size as a residence light switch by the door. For one-half hour I tried to place switch engines on sidings and at facing point switches that could wreck an oncoming train, and found it absolutely impossible. The device routes all trains to a safe course within the limits of the terminal. The minute the switch is thrown or any signal is operated in opposition, the dispatcher, as he was formerly called, has nothing to do with the routing of the train. Given a certain condition at the particular switch, the apparatus automatically routes the train along other lines that are clear.

It would take pages to express the awe and wonderment I experienced during the hour I was going over the installation. The apparatus, called the "N X Interlocking Unit" does everything but talk to you, sign checks and scratch your back, and I would not be surprised if it will be doing two of these operations within the near future.

There are only three such installations in the world, a very small one at Paddington Junction, London, another one at Gerard Junction, Erie, Pennsylvania, and the two very large boards at either end of our San Francisco-Oakland Bay Bridge. Installation for the bridge control costs approximately a million and a half dollars but it is worth it. It is also consistent with the thoroughness, intelligence, foresight of that master builder, Charles H. Purcell, to whom we are indebted for the bridge itself, and we who patronize the trains over that bridge may read or doze in the security of a positive knowledge that no accident can happen.

ANSWERS THE TREND TO LARGER UNITS



Architect, Wilton Smith. L. B. Monroe residence, Rio del Mar, California

It Now Costs Scarcely More Installed than Ordinary-size Tiling

These smart new 6 x 9's . . . now more of your clients can afford them. *We have priced this new Master Kraftile to cost scarcely more than old-fashioned small-size tile installed.*

And to make it easier for you to "get across" your interpretations of this modern trend to simpler, larger units, here's something else we're doing.

We're publishing full-page four-color ads on Master Kraftile this year in *Sunset*—the favorite magazine of over 200,000 Western home lovers. Look forward to an increasing interest in this "smartest trend in wall tiling since color."

Write us for complete information. Our Engineering and Interior Decoration staff will gladly cooperate with you in any way possible. Mail coupon today.

MASTER KRAFTILE 6 x 9's

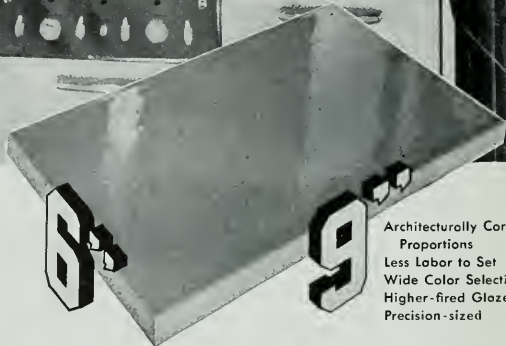

Architecturally Correct Proportions
Less Labor to Set
Wide Color Selection
Higher-fired Glaze
Precision-sized

HOW 6 x 9's "STRETCH" SMALL WALL SPACES

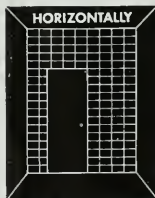

Set horizontally, Master Kraftile tends to make narrow wall spaces look wider. Set vertically, short walls appear a little higher. And either way, these modern 6 x 9's create an illusion of spaciousness

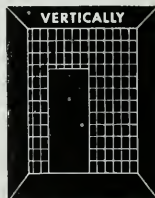

FREE to Architects and Builders

KRAFTILE COMPANY, Niles, California

Please send me, without cost or obligation, further information about Master Kraftile and suggestions for its use in the newer kitchens and bathrooms (....) Please have service representative call (....)

Name _____
Address _____
City _____ State _____

The Architect & Engineer

Fred W. Jones, Editor

Mark Daniels, A. I. A., Associate Editor

Edgar N. Kierulli, Assistant Editor

CONSULTING BOARD OF EDITORS

Architectural—

Arthur Brown Jr.
Frederick H. Meyer
Timothy L. Pflueger
Will G. Corlett
Harry Michelsen
John J. Donovan
Lewis P. Hobart
David C. Allison
Gordon B. Kaulmann
Harris C. Allen
Glenn Stanton
Paul R. Hunter
C. H. Alden

Engineering—

H. J. Brunnier
L. H. Nishkian
William Adrian
Wm. H. Popert
Homer N. Hadley
John J. Gould
Geo. E. Atkins

Advertising Manager—

J. Leslie Meek

Architects' Reports—

Vernon S. Yallop

THE ARCHITECT AND ENGINEER, INC., 68 Post Street, San Francisco, EXbrook 7182. President, K. P. Kierulli; vice-president, Frederick W. Jones; secretary, L. B. Penherwood. Los Angeles office, 832 W. Fifth Street. Published on the 12th on each month. Entered as second class matter, November 2, 1905, at the Postoffice at San Francisco, California, under the Act of March 3, 1897. Subscriptions, United States and Pan America, \$3.00 a year; Foreign countries, \$5.00 a year; single copy \$.50.

Frontispiece

Interior of San Francisco-Oakland Bay Bridge Terminal . . . 16

Text

Running Fire 1
Mark Daniels, A.I.A.

Trees—How and When to Plant Them 8
Berniece Ashdown, Landscape Architect

The San Francisco-Oakland Bay Bridge Railway Terminal . . . 17
Fred W. Jones

Money and Property Values 33
Lawrence Kiebler

Modern Architecture 38

Scottish Rite Temple, Oakland 41

Favorable Outlook for 1939 Building 42

Competitions 49

Versatility—The Engineer-plus 51
John C. Page

Construction Activity for 1938 54

Architects' Bulletin 55

Plates and Illustrations

The San Francisco-Oakland Bay Bridge Railway Terminal . . 16-32

Scottish Rite Temple, Oakland 40-41
Will G. Corlett, Architect

Residence of Mr. and Mrs. Hans Von Geldar 46
Lawrence A. Kruse, Architect

Residence of Mr. and Mrs. Harley L. Hooper 47
Lawrence A. Kruse, Architect

House for Ian Campbell 48-49
Erle Webster and Adrian Wilson, Architects



LAMELLA TEST ROOF DURING FINAL EXPERIMENT. SHEATHING REMOVED ON CENTER OF ROOF. END DIAPHRAGM SHEATHING REMOVED LEAVING ENDS UNSUPPORTED. STEEL ANGLES APPROXIMATE WEIGHT OF ROOFING. IN THIS TEST A LATERAL LOAD OF 390 POUNDS PER LINEAL FOOT OF SILL WAS APPLIED ON THE WEST SILL ONLY.

Lamella Roof Test Under Vertical and Lateral Loads

THE results of an exhaustive series of tests on a full size lamella roof has been announced. These tests were conducted September 15, 16 and 17 of last year in Los Angeles by the Summerbell Roof Structures under the Supervision of Frederick J. Converse, California Institute of Technology.

The tests were made to verify by actual field measurements an analysis made by Dr. Theodore von Karman, Director of the Guggenheim Aeronautical Laboratory, California Institute of Technology. Dr. von Karman's analysis covered the action of the lamella roof under both vertical and lateral loads.

Vertical load tests had previously been made on a full size roof but lateral load tests had only been made on model structures. To make certain that any speculations as to the correctness of the application of test data obtained from model tests might not arise, it was decided to make the tests on a full size roof.

A roof forty feet wide and fifty-one feet ten and one-half inches long with a rise of six feet seven inches, was constructed in the Los Angeles yard of the Hammond Lumber Company. The four corners of the roof structure were held against lateral motion by means of kickers to the old concrete foundations over which the roof was constructed. The structure was otherwise unrestrained and the side sills of the roof were supported on steel rollers.

[Please turn to Page 71]



APPLYING LATERAL LOAD ON WEST SILL ONLY BY MEANS OF HYDRAULIC JACKS. DISTRIBUTING BEAM SYSTEM FOR EVEN APPLICATION OF LOAD TO SILL IS SEEN IN FOREGROUND.

**DON'T TRY TO
MUFFLE
THE ROAR...**



ELIMINATE

IT!

● Anyone who has installed mufflers in flush valves knows the difficulty of first determining the correct number of screens—and the certainty that they will eventually clog. Then there is always the knowledge that failure to clean clogged mufflers will cut the water supply below the amount necessary for the fixtures.

Sloan *Quiet-Flush* is *not* a muffler. It is unlike any other silencing device. In the new Sloan *Quiet-Flush* Valves there is a completely redesigned stop and in the valve itself a new type of guide and seat. Sloan *Quiet-Flush* Valves are available in the Star, Royal, Crown and Naval models.

Moreover, the new Sloan silencing elements are available for present installations, with the result that Sloan Valves, regardless of when installed, may now be made absolutely quiet. Send today for descriptive literature and full details.

See our comprehensive Catalog in Sweets

SLOAN VALVE COMPANY • CHICAGO

4300 WEST LAKE STREET

SLOAN *Quiet
Flush* **VALVES**

Trees — how and when to plant them

by *Berniece Ashdown*

Landscape Architect

BECAUSE of its tremendous aesthetic and economic values, too much can not be said about street planting. Cities with properly planted streets are healthier, more comfortable and more beautiful places in which to live; to say nothing of the fact that trees increase the property values.

Perhaps because of the abundance of natural forest land found by our American pioneers, trees in our American cities have been less valued than in the cities of Europe. Paris owes much of her beauty to the 80 000 trees planted on her streets and other European cities follow closely in the wake of her splendid example.

Of California cities, a few, including Longwood, Montecito, Beverly Hills, Santa Monica, and Palos Verdes can boast of well planted streets.

To achieve unity in planting, a carefully worked out scheme should be followed. The avenue effect used by the French is to be recommended. Trees may be planted on both sides of the street or with a row down the center. If the street is wide, there may be two rows. On narrow streets, trees may be planted behind the property lines. Arrangements should be made with the tenants to carry out a consistent scheme of spacing. Another excellent scheme is to plant clumps or groups of two, three, five or six trees together.

Spacing should allow views to be framed. Trees planted too close become monotonous, tiresome and fatiguing, are apt to give the impression of a high picket fence. If they are planted equidistantly they should never be closer together than thirty feet. Large trees may be forty to a hundred feet apart.

Different streets may be planted with different varieties. Such factors as blooming season, foliage, etc. should be taken into consideration when the choice of trees is made.

Varieties should be carefully chosen with regard to locality and situation. Before deciding what to plant it is best to make an inspection of trees in the neighborhood to determine which are most hardy.

Trees for manufacturing and smoky districts may include Planes, Norway Maple, Sycamore, Poplars, and Ash.

For cold exposed positions plant Maple, Sycamore, Oak, Poplar, Elm, Birch, Ash and Willow.

If soil is a problem in your locality, special care should be exercised in selecting trees that will be congenial with the conditions. Norway maple, Sycamore, Poplars, Birch and Ash all do well in chalk soil. In sandy places plant Sycamore and Oak. For seaside situations Sycamore, Norway Maple,

Turkey Oak, Comphordown Elm, Grey Poplar, White Willow, Common Oak, and Monterey Cypress.

There are many places in the low sections of the country where excessive moisture is a problem. To meet this situation there are several trees which require a great deal of water, including the Willow, English Walnut (which may be seen growing to perfection in Ventura and El Monte) and the Magnolia.

In dry sections nothing is finer than the drought resistant Carabs, Arizona Ash and Cottonwood.

Among the decorative trees we have Paper trees, Scarlet Eucalypti, Jacaranda, Japanese flowering cherries, Sederoylon rosea, Coral tree (Bauhinias), Plum, Almond, Crab, Catalpa, Horn Chestnut, Hawthorn and Acacia.

The large street trees include Horse Chestnut, Elm, Plane, Lime, and Beech. These should all be given a great deal of room for expansion.

In conclusion I wish to say that the importance of proper care and maintenance of street trees after they are planted can not be over emphasized. Too often we see trees shabby or dying while with a little care they are splendid symbols of their forest kin which inspired George Sterling to write:

Oh Trees! so vast, so calm!
Softly ye lay
On heart and mind today
The unpurchaseable balm.

GARDEN NOTES

Rhododendrons and azaleas do best when kept mulched the year around with old leaves or pine needles.

Eucalypti have been known to grow fifty feet tall in five years.

WHO DESIGNED THEM?

How Good is Your Memory?

The old **Claus Spreckels Building**, Third and Market Streets, San Francisco (now the Central Tower) was designed by—

- (1) Willis Polk
- (2) Reid Bros.
- (3) L. B. Dutton

The remodeled **Spreckels Building**, was designed by—

- (1) T. L. Pflueger
- (2) Geo. W. Kelham
- (3) Albert Roller

The **Humboldt Bank Building**, Market, near Fourth Street, San Francisco, was designed by—

- (1) Meyer & Ward

(2) Meyer & O'Brien

(3) Reid Bros.

The **Realty Syndicate Building**, Oakland, was designed by—

- (1) Edw. T. Foulkes
- (2) Reed & Corlett
- (3) Wm. L. Woollett

The **Berkeley City Hall** was designed by—

- (1) Bakewell & Brown
- (2) J. W. Plachek
- (3) W. H. Ratcliff, Jr.

The **James Flood Building**, San Francisco, was designed by—

- (1) D. H. Burnham & Co.
- (2) William Curlett
- (3) Albert Pissis

The **Pacific Building**, Market & Fourth Streets, San Francisco, was designed by—

- (1) Charles F. Whittlesey
- (2) Landsburgh & Joseph
- (3) L. B. Dutton

(Correct answers on Page 68)

*A few hours
a few dollars*
AND

Sealcon
WILL MAKE YOUR
BASEMENT

DRY

SEALCON forms a water-resisting seal for basement walls and floors, brick, stucco or any other masonry. Just paint it on, inside or outside, to any wet or dry surface. One coat gives lasting protection . . .

conquers dampness and seeping water. A perfect base, or mixture, for oil paint.

**EASIER
TO APPLY
THAN PAINT**

ASK DEALER
LISTED
BELOW
ABOUT



Sealcon
GUNN, CARLE & CO.
Distributors
20 Potrero Ave. UNDERHILL 5482
SAN FRANCISCO

GLASS by FULLER



Painting Contractors
D. ZELINSKY & SONS, INC.

FULLER
PAINTS
they last



A building of architectural beauty and practical utility, the new Railway Terminal for commuter train over the San Francisco-Oakland Bay Bridge was opened for regular traffic January 15. The picture shows artist's conception of interior of structure.

Electric trains from metropolitan Oakland are shown on the mezzanine at right; streetcars are pictured on the left.

THE
ARCHITECT *and* ENGINEER
January, 1939



Photo by Moulin

MISSION STREET FRONT OF TERMINAL BUILDING. NOTE BAY BRIDGE
IN THE BACKGROUND.

Progress —

The San Francisco-Oakland Bay Bridge Railway Terminal

by Fred W. Jones

AFTER more than three-quarters of a century of discussion and planning, San Francisco has for the first time a direct railway connection from the east. By the time you are reading this the San Francisco-Oakland Bay Bridge Electric Railway will be in operation and ferryboats for pedestrians will be in memory only, except to Treasure Island. Key System, Interurban Electric (Southern Pacific subsidiary) and Sacramento Northern trains will operate over the lower deck of the Bay Bridge.

The historic Ferry Building will no longer be witness to the tens of thousands of commuters pouring daily through its well-worn corridors.

Replacing the functions of this famous landmark will be a modern and handsome Terminal facing Mission Street and extending from a point just west of Beale to a distance approximately 300 feet west of First Street.

A concrete viaduct will carry the trains between the bridge and the terminal. Moving in clockwise manner east to west, the trains will loop into the building at elevation.

More centrally situated than the Ferry Building, the new Terminal will bring 50 per cent of train passengers to within walking distance of their destinations, it is estimated. This is an increase by approximately 25 per cent over the

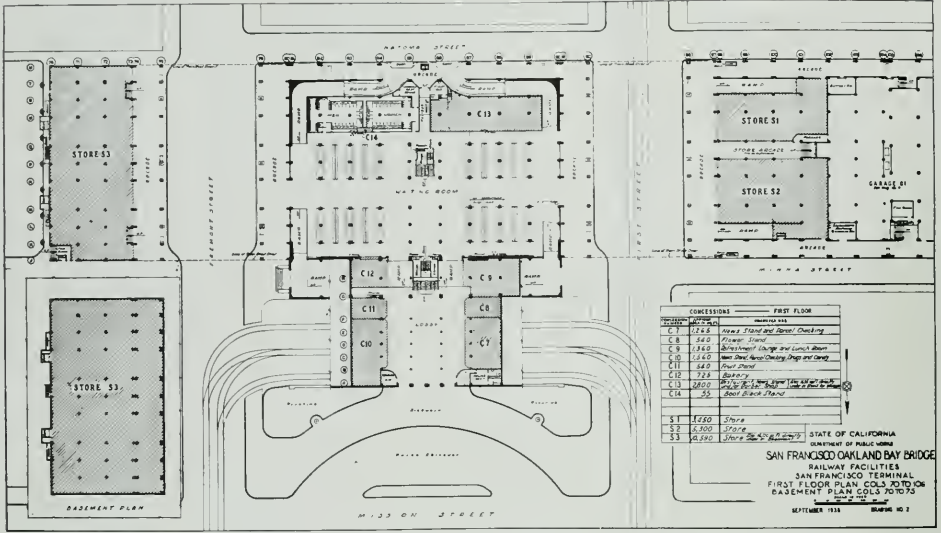

PLOT AND GROUND FLOOR PLAN, SAN FRANCISCO-OAKLAND BAY BRIDGE TERMINAL, SAN FRANCISCO, CALIFORNIA

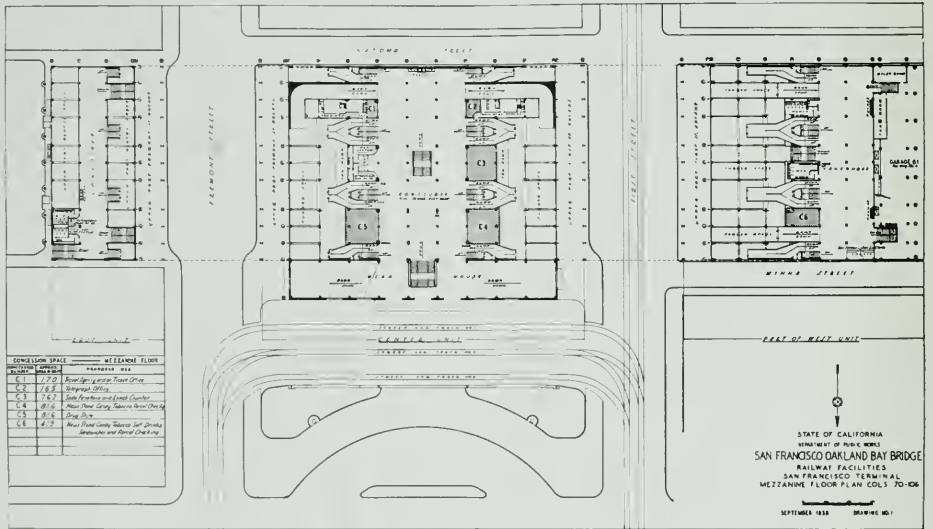

MEZZANINE FLOOR PLAN, SAN FRANCISCO-OAKLAND BAY BRIDGE TERMINAL, SAN FRANCISCO



MISSION STREET FRONT, SAN FRANCISCO TERMINAL
OF SAN FRANCISCO-OAKLAND BAY BRIDGE ELECTRIC
RAILWAY

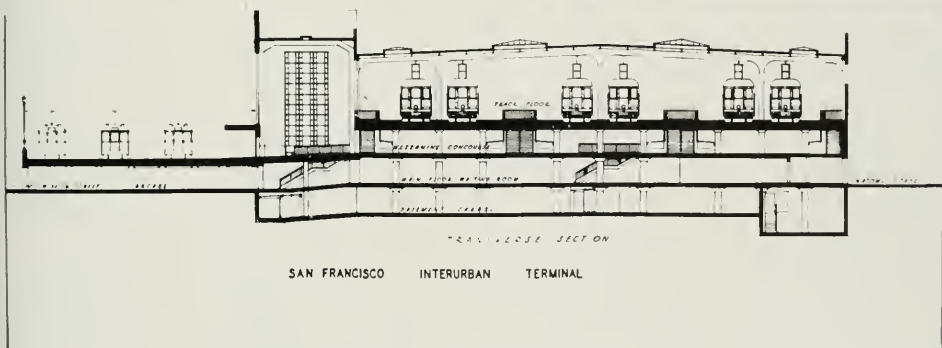

ENGINEER'S DRAWING, TRANSVERSE SECTION, OF THE SAN FRANCISCO
TERMINAL OF THE SAN FRANCISCO-OAKLAND BAY BRIDGE ELECTRIC
RAILWAY

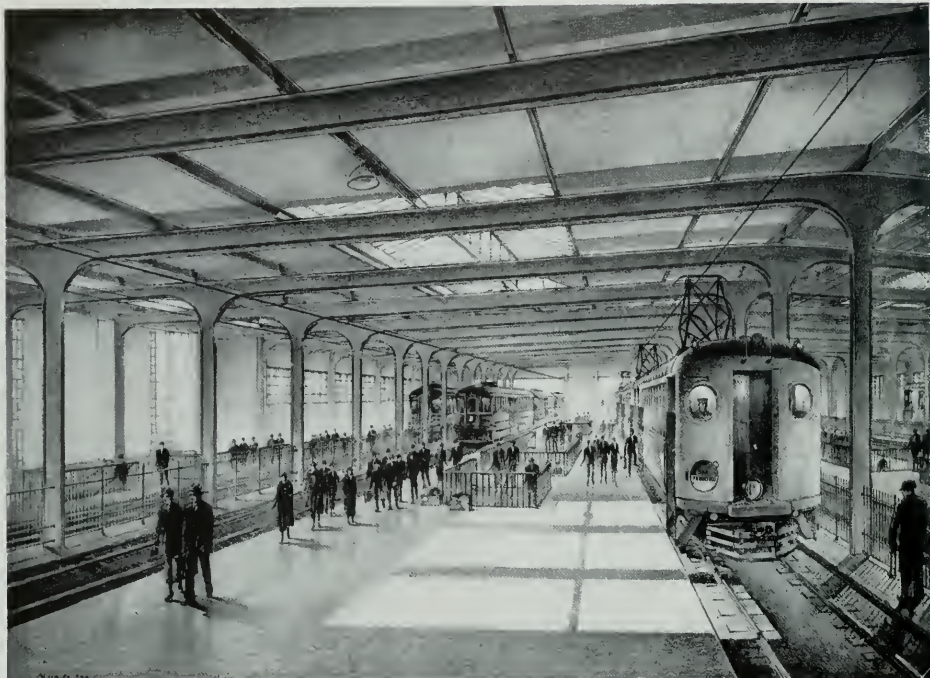

Architect's drawing shows the loading platforms and tracks for the San Francisco-Oakland Bay Bridge electric train system at the San Francisco Terminal. All tracks and platforms are roofed for a length of 700 feet, with large skylights and windows providing abundant lighting.

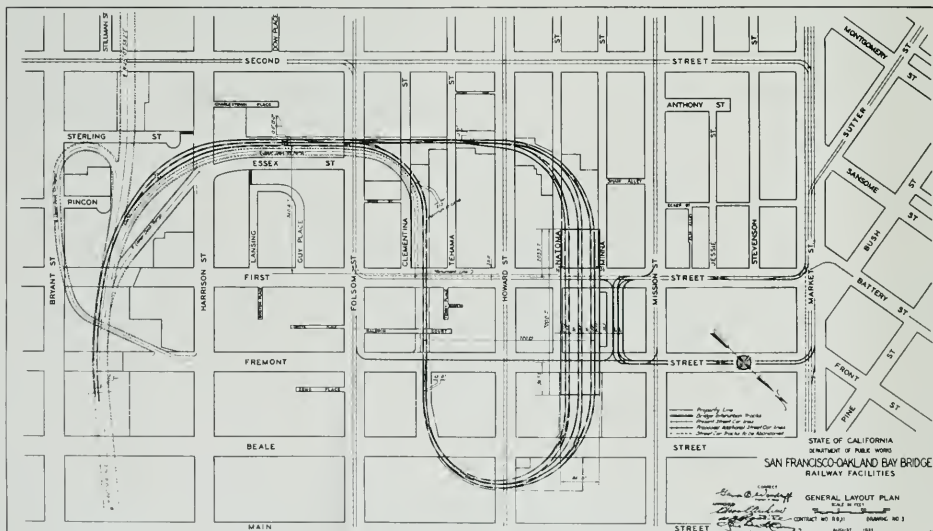

GENERAL LAYOUT PLAN



This "cut away" drawing of the San Francisco Terminal shows how passengers traveling to and from East Bay points reach their destinations in the structure.

Electric trains enter on the upper level over six tracks entirely enclosed within the building.

To reach street cars from the trains, passengers can take either short ramps or brief flights of stairs leading directly from the train platforms to the mezzanine.

Street cars loop over a viaduct in front of the Terminal building at the mezzanine level.

To reach the street level, passengers leave the mezzanine by means of a flight of stairs.

Waiting rooms and concessions are on the street level. Information and ticket offices are on the mezzanine.

At no time will passengers cross the tracks to reach, or depart from, their trains, but will utilize the stairs or ramps leading from the train platforms to the concourse below.



Spacious waiting rooms on the street floor of the new Terminal Building provide comfort to passengers traveling on the San Francisco-Oakland Bay Bridge electric railway system.



Bay Bridge electric railway trains enter and leave over this track level in the Terminal Building. Six tracks have been provided for Interurban (S. P.), Key System, and Sacramento Northern trains. Eleven ramps and fourteen stairways afford ample access to and from trains.

number hitherto walking to and from the Ferry Building.

Street cars will loop from Market Street over a ramp directly in front of the structure and level with the mezzanine floor. Both Municipal and Market Street Railway cars will provide service. The cars will turn from Market Street on First and return via Fremont Street.

TERMINAL IS OF REINFORCED CONCRETE

Convenience to passengers was the governing motive in the design of the Terminal. To this end the structure was developed less as a typical railroad station than as a system of enclosed ramps and stairs so arranged as to provide minimum walking.

The Terminal Building is an 870-foot long flat slab reinforced concrete structure, faced with California granite. It is extremely simple in design and without ornament, except for aluminum trim. Its most extravagant features are the seven handsome two-story windows which extend across the front of the building. A window, each of the same type, also faces on Fremont and on First Street.

Comprised of three stories and a basement, the structure might also be said to be composed of three units. Although the track level, or third floor, runs for the entire length of the building, the mezzanine and street floors are divided by Fremont and First streets into east, center, and west units. Rigid steel frames support the track level over these streets and provide an attractive archway for pedestrian and vehicular traffic.

The east and west units are each 164 feet wide; the center unit is 197 feet wide. Each unit has mezzanine and street floors and basement. The west wing and the basement of the center unit will be leased as a garage concession. Equipped to accommodate more than 600 cars, it is the largest public garage in San Francisco.

Spacious waiting rooms, rest rooms and concessions are located on the street floor of the center unit. Space for stores has been provided on the east side of Fremont Street and the west side of First Street.

The mezzanine floor is in reality a concourse. It will be necessary for the passenger to select

his train from the directional signs on the mezzanine which will indicate the proper track and the stairway or ramp to be taken; although passengers will find their trains on the same track each time. There are seven ramps or stair connections serving a train, thus facilitating passenger distribution. Ramps have a maximum grade of 10 per cent and are treated to be anti-slip.

ILLUSIONARY HEIGHT PRODUCED

To carry out still further the plan of curtailing walking distances for passengers, heights between floors have been reduced to a minimum. Between the track level and the mezzanine there is a vertical distance of 10 feet; between the mezzanine and the street floor, a vertical distance of 10 feet, making a total vertical distance from train to street of 20 feet.

Information booths, ticket offices and concessions are located on the mezzanine. A loud-speaker system will announce train departures.

Ceilings of the building are of plaster painted an off-white. The effect is to produce an illusionary height. Walls are of tile and floors of terrazzo. Lights are recessed in the ceilings providing a diffused glow that gives a daylight effect. An air-conditioned heating and ventilating system is an important part of the mechanical equipment.

Large skylights and windows on the track platform provide ample lighting within for daytime use. There are six tracks with platforms between alternate trains. A fence between each platform will prevent passengers from crossing the tracks. To eliminate undue noise, track ties are embedded in concrete which is insulated by a two-inch cushion from the construction.

Interurban electric trains will enter the Terminal over the three northerly tracks, Key System and Sacramento Northern trains over the three southerly tracks. Interurban and Sacramento Northern will receive their power through a catenary and Key System through a contact rail. Key System operates on 625 volts; Interurban on 1350.

It is estimated that the average waiting period per passenger during normal hours will be 10 minutes. During peak hours trains will



Passengers for the Bay Bridge electric railway find their trains through means of directional signs placed on the mezzanine floor of the Terminal Building. Floors are terrazzo with tile columns and specially-treated ceilings. Ticket offices are visible in the left center.



Passengers for Bay Bridge electric trains enter this foyer of the Terminal Building. The view, taken on the mezzanine floor, shows the track level to the upper left. Stairs in the center foreground lead to the street floor.

operate on a 75-second headway. The bridge railway system has, however, been designed to operate on a 63-second headway when necessary. Approximately 5 minutes has been allowed for each train to remain in the station for the loading and unloading of passengers.

More than 60,000 persons daily, under conservative estimates, will pass through the Terminal. The bridge railway facilities have been designed for a maximum annual traffic of 50,000,000 persons, with a 20-minute peak of 17,000 passengers in one direction. Such a peak would require 10-car trains operating on a 65-second headway. It is expected that peak traffic at the start will require 16 trains in a 20-minute period.

The Terminal was constructed at a cost of \$2,300,000. MacDonald and Kahn were general contractors. Columbia Steel Company had the contract for structural steel erection; Radelfinger Brothers, electrical work; and Scott Company, mechanical work.

MARVELOUS SIGNAL CONTROL

Housed on the track level of the Terminal is the San Francisco plant for the Bridge Railway's automatic interlocking system. This "plant" in reality consists of a six-foot desk-like instrument. The track design of the terminal and viaduct is etched on the upright face of the "desk." Lights on the track diagram show the position of those trains within the section covered by the interlocking plant. To clear signals and set the switches, the operator has only to push the proper buttons at the beginning and termination of the route.

A similar control board is placed in the signal tower in the East Bay Yard, differing only in its design, which has an etched diagram of the yard tracks. It is possible for the San Francisco operator to know from lights bearing train numerals or letters placed on the board which train is entering the loop section. The San Francisco operator in turn is able to indicate to the Oakland operator in a similar manner which train is about to enter his section so that the proper route may be set accordingly.

With the bridge railway designed to operate under a 63-second headway, only the most perfected signal devices could be utilized. Cab

signals with train-control devices have been installed in all trains of the three railroads.

Cab-signal boxes are placed at the front and side of the motorman, easily discernable. The four permissible speed limits are indicated in this box by illuminated colored numerals. Mounted at the head of the train in front of the first axle, approximately 6 inches above the rails, is a pair of receiver coils that pick up the signal current by induction.

A white light is shown when the authorized speed is reached. Should the speed be exceeded by 1 mile per hour, a whistle warns the operator; should the speed still further exceed the designated limit by 1 mile per hour an emergency brake is automatically applied.

The operator is allowed $2\frac{1}{2}$ seconds to respond to the warning after the cab-signal indicates a more restrictive speed. When a Red 11 is received (indicating a speed of 11 MPH) an additional distinctive signal is sounded and the operator is required to press an "acknowledging" lever within $2\frac{1}{2}$ seconds.

AUTOMATIC EMERGENCY BRAKES

Failure to comply with any one of these requirements results in an automatic application



PARKING AREA UNDER THE BRIDGE VIADUCT, WESTERLY END OF TERMINAL BUILDING



Bird's-eye-view of the San Francisco Terminal Building. In the background is the Bay Bridge span. A glimpse of Treasure Island, site of the 1939 Golden Gate International Exposition, may be seen in the left background.

Trains travel over the lower deck of the bridge and loop into San Francisco over a viaduct, in an east-west direction. The Terminal Building is equipped to handle with ease a daily commuter traffic of 35,000 persons.

of the emergency brake. Both wayside and car circuits are so designed that any defect or failure in equipment will result in a more restrictive control rather than permit unsafe operation.

Speed indications are governed by the condition of the track ahead. On down-grade portions of the bridge where braking distances are greatest, the blocks are 507 feet long. Four clear blocks ahead are indicated by 180 interruptions; two or three clear blocks by 120 interruptions and one clear block by 75 interruptions per minute. A train in the next block ahead or in the immediate block in denoted by a steady current or no current.

Arrangements of the codes and speed controls are as follows:

Code Interruptions per min.	Cab Signal Aspect	Authorized Speed M.P.H.	—Speed Above Which—		Which Applied M.P.H.
			White Lighted M.P.H.	Warning Signal Sounded M.P.H.	
180	Green	35	35	36	37
120	Yellow and Green	25	25	26	27
75	Yellow	17	16½	17½	18½
None	Red	11	10¾	11¾	12¾

The General Railway Signal Company is the contractor for the Bridge Railway's signal and interlocking system.

The viaduct between the Terminal and the main bridge consists mainly of a series of reinforced concrete rigid frame structures with clear spaces varying from 60 to 85 feet. Steel

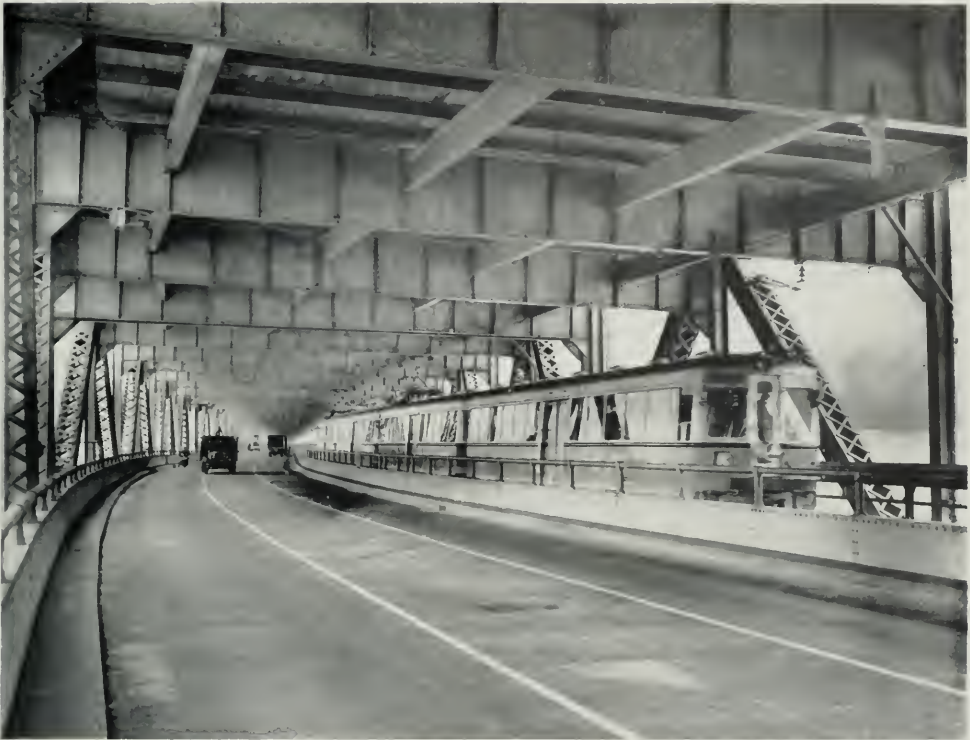

This photograph shows the first electric train to cross the San Francisco-Oakland Bay Bridge. The occasion was a test trip for the automatic cab control signal equipment.

Informal ceremonies marked the event, with Former Governor Frank F. Merriam, chairman of the California Toll Bridge Authority, at the controls. The train started over the lower deck from 40th and Hollis Streets, Oakland, proceeded to Pier W-1, a point above the Embarcadero in San Francisco.

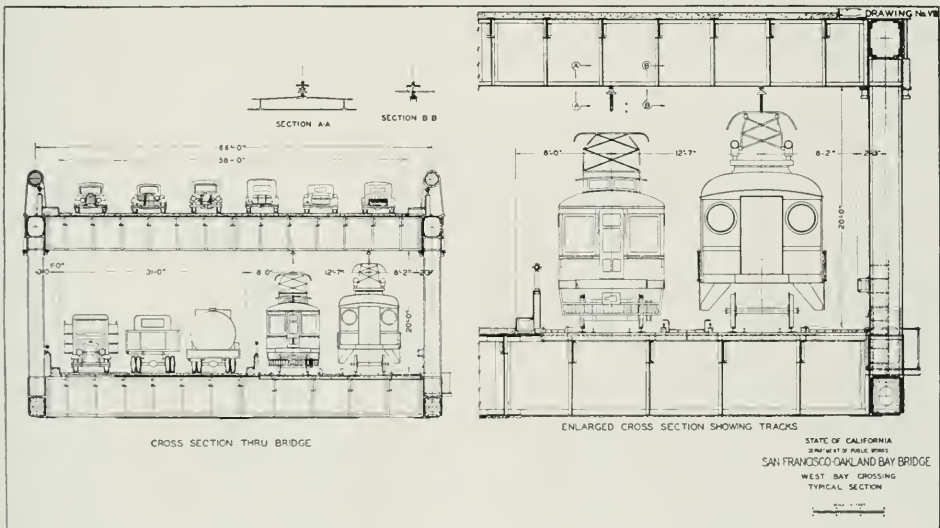



Graphic combination aerial view and artist's drawing illustrating how the San Francisco Bay will look when the Exposition opens in February. Front foreground is the viaduct and the Bridge Terminal Building extending to the great $4\frac{1}{2}$ -mile steel span. Left center is the completed Treasure Island showing the roadway connections via Yerba Buena Island to the Bay Bridge. The photograph, taken from San Francisco, looks eastward to Berkeley and Oakland.

girder spans were used over the more heavily traveled streets in order to avoid falsework at these points required for concrete spans. Unsatisfactory foundation conditions also made the use of steel spans desirable at the east end of the loop, where foundation loads were kept to a minimum.

Ballasted construction has been used on the viaduct to reduce noise.

Trackwork on the bridge proper is of open deck construction in order to keep within the dead load required by the design. Redwood ties, 8 inches by 9 inches on 12-inch centers were used principally because of the natural fire-resistant properties of this material. Four-inch spacer blocks, 12 inches long, were placed between the ties under each rail to prevent the ties from bunching. Profiles were run over each

stringer for the entire length of the bridge and each tie dapped to the nearest eighth of an inch to insure an equal bearing of each tie and a smooth track surface.

TRACK EXPANSION PROBLEM SOLVED

Track expansion was a problem which had to be solved, particularly at the towers of the West Crossing suspension spans and at Tower E-4 in the East Crossing.

Provision had to be made at the E-4 joint for a total horizontal expansion of 39 inches, and for changes in vertical and horizontal angles resulting from vertical and horizontal deflections of the structure.

So that signal circuits would not be shunted, rails had to be insulated from each other, and to keep the return propulsion current insulated from the bridge the entire assembly had to be insulated from the steel.

This was accomplished by obtaining a continuous gauge through an outer curved rail, which was held to gauge by guides and was permitted to slide against a fixed point rail. Continuous guard rails are secured to sliding plates, and opposite the sliding point of the track rail the guard rail is replaced by an "easer" which slightly lifts the wheel above the point.

The total 39-inch expansion was considered to be too great to take at one point. This was solved by cutting the rails in two places and dividing the expansion equally between the two points by an equalizing lever. Thus the joint has two 19½-inch expansion movements.

Ninety-pound running rail and guard rail is used for the bridge railway track system except at the sharp curves in the San Francisco viaduct where a 110-pound guard rail has been installed. The contact or third rail is 150-pound special.

Three substations will supply the electrical energy at 12 k.v. to the Bay Bridge railway. These are located in San Francisco on Rincon Hill, known as Sterling Substation; on Yerba Buena Island, back of the bridge garage, known as Island Substation, and on the Oakland mole at the easterly end of the bridge, termed the Mole Substation. Conversion at the Island

Substation will be to 625 volts; at the others to both 625 and 1350.

Covering an area of 43 acres, the East Bay Yard will have storage facilities for 228 cars in addition to two set-out tracks 720 feet long in each direction for the Key System and Interurban Electric trains. There are in addition two inspection buildings, 75 feet by 340 feet for the Interurban Electric and 80 feet by 370 feet for the Key System. The Oakland signal tower is also located in the yard.

When trains are to pick up or drop cars they will be routed through the set-out tracks. Automatic couplers on trains will permit cars to be dropped without a stop. In adding cars it will be necessary to stop only momentarily.

The importation of approximately 310,000 tons of sand and gravel was necessary to reclaim this area.

CAR EQUIPMENT SUMMARIZED

Key System trains to be used on the span were designed for the bridge railway. Interurban Electric and Sacramento Northern will use the same trains as at present except for alterations to their equipment necessary in adapting it to the bridge signal system. Automatic couplers and improved airbrakes have also been installed. Interurban's modified equipment comprises 95 motor cars, 15 operating trailers, and 35 non-operating trailers. The Key System's equipment includes 88 two-body articulated units. Of these 23 were new and the remainder, except for the bodies, constructed from materials salvaged from previous equipment. Sacramento Northern's altered equipment comprises 17 motor cars.

Eighteen contracts were let by the State Department of Public Works for the construction of the \$18,500,000 bridge electric railway system. These include:

Contract & Description	Contractor	Amount
Demolition and wrecking of buildings for terminal & viaduct	Cleveland Wrecking Co.	\$121,175.00
San Francisco Terminal,	divided as follows:	
General Construction	MacDonald & Kahn, Inc.	\$1,658,510.00
Structural Steel	Columbia Steel Company	442,360.00
Mechanical Work	Scott Company	109,257.00



Photograph shows the first of the San Francisco-Oakland Bay Bridge railway expansion joints to be installed on the span. This expansion rail is the smallest of the 22 placed on the bridge proper and has an expansion of approximately 14 inches. It is located at Pier E-11.

The running rails "D" in the photograph are attached to the steel plate "C." The rails may automatically move in the direction indicated by the arrows when a condition causing expansion exists. The running rails "B" are attached to the steel plate "A" and may move in the direction indicated by the arrows.

The rail point near the workman's right hand is fixed to the gauge of the track; while the curved rail "D," near his left hand, moves backward and forward according to the degree of expansion; but always against the point of rail "B."

The largest and most complicated expansion joint is at Pier E-4 where there is an expansion allowance of approximately 39 inches.

This expansion joint is duplicated on the parallel track which carries San Francisco-bound traffic.

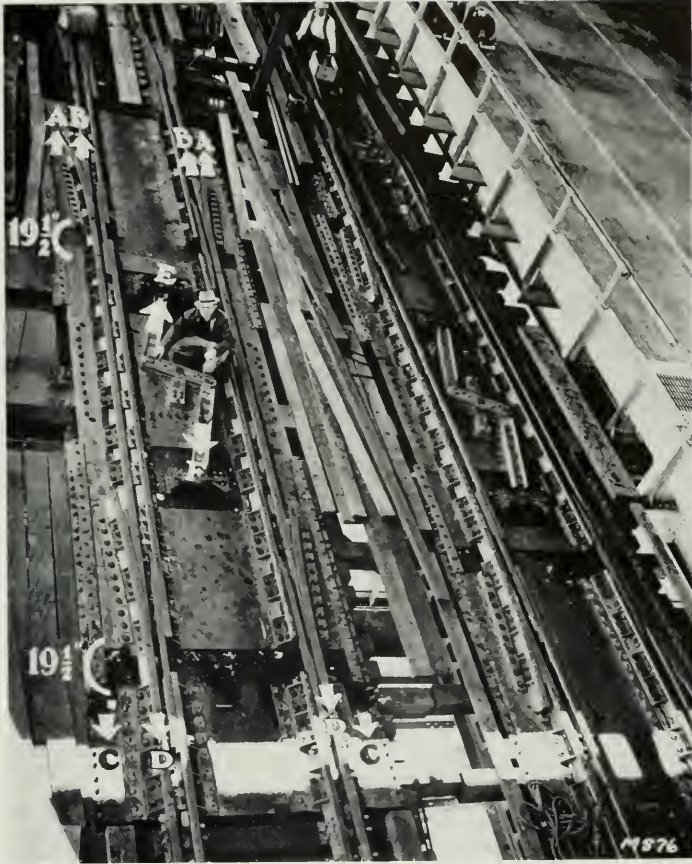

The world's largest expansion rail is on the Bay Bridge electric railway on Pier E-4, pictured here. The rail at this point has a total expansion of 39 inches. Because of its great length, engineers of the Bay Bridge under Chief Engineer C. H. Purcell designed two movable rail points, each of which takes one-half of the total movement or $19\frac{1}{2}$ inches.

This movement is controlled by the lever-like device (Figures E & F) constructed on a steel plate in the center of the track. During expansion the running rails (Figures B), which are bolted to the steel plate (Figures A) pull opposite to the running rails (Figures D) bolted to a separate steel plate (Figures C); and the steel lever (Figure E) moves in a similar direction. Likewise, the lever (Figure F) moves in the same direction as the running rails (Figures D). At maximum expansion, the lever-like device is practically straightened.

The curved rails shown in the picture slide against the rail points, maintaining a connection at all times.

The total length of the rail expansion joint is 22 feet at normal position and the total weight is approximately 11 tons.



San Francisco-Oakland Bay Bridge electric trains operate under the most modern electric interlocking and signal system.

Pictured above is the control board installed in the Signal Tower of the East Bay Yards. On the right, for comparison, is an old-style lever system.

Had the mechanical lever system been used for the Bay Bridge railway, it would have been necessary to have had 92 levers, occupying a switch tower 60 feet

long for the East Bay yards alone. The bridge control board is only 6½ feet in length.

On the automatic control board, trains are routed by merely pressing the proper buttons placed at switch points on the diagram of the yard track system.

In the picture, Ross Davis, resident engineer for the signal installation, is demonstrating the use of the board.

A similar control board, operating switches in the San Francisco Terminal, will be installed in that structure at a later date.

Below A. C. Jensen shows how the old style mechanical lever system works.



The Bridge Electric Railway and San Francisco Terminal will be maintained by the Interurban Electric and Key System.

For the use of the facilities the railroads will pay to the State-controlled California Toll Bridge Authority a toll of 2½ cents per passenger. This toll will not affect the present transportation rates paid by transbay passengers, which will remain unchanged for at least 18 months, according to agreement.

The bridge railway system was constructed by the State Department of Public Works, Charles H. Purcell, Chief Engineer, Charles E. Andrew, Bridge Engineer, and Glenn B. Woodruff, Engineer of Design. The Board of Consulting Architects comprised Timothy L. Pfeuffer, Arthur Brown, Jr., and John J. Donovan.

Electrical Work	Radelfinger Bros.	73,250.00
San Francisco viaduct	Eaton & Smith	605,350.00
Substructure for 3 overhead crossings & East Bay storage yards	Bates & Rogers Construction Co.	684,802.00
Railroad signals and interlocking work	General Railway Signal Co.	1,368,402.00
Telephone system	Abbett Electric Co.	16,404.00
Superstructure of East Bay storage yards & 2 railway overheads & Port of Oakland overhead	J. H. Pomeroy & Co.	536,960.00
Inspection buildings in East Bay Yard	Fred J. Early, Jr.	132,352.50
Trackwork & contact rail, main bridge & SF loop	Pacific Bridge Co.	469,236.50
Catenary & feeders for bridge & SF loop		
Catenary & feeders for East Bay Yards	Barrett & Hilp	370,283.00
Track bonding, bridge & SF loop		
Track bonding, East Bay Yards	General Welding Co.	32,527.05
Trackwork & contact rail, East Bay Yard	Bates & Rogers Construction Corp.	428,363.75

Finance

Money and Property Values

by Lawrence Kiebler

Vice Pres. Wulff Hansen & Co.

THE subject on which I was asked to speak is one that takes years of study and some hours to explain clearly. Naturally, in the allotted time, it is going to be difficult to get it over. I will ask you to keep in mind that I am interpreting history in terms of the principles of money and inflation and applying them to your particular situation; but, in order to do the latter, I will have to give you a background of the methods and inevitable results of the monetary policies of the Government today.

Now that war is temporarily in the background, the greatest single force operating in the world today is inflation or depreciation of money. All world currencies are untied from gold, and all major nations are spending more than their income and paying the deficit by printing irredeemable paper. Most business men know there is such a thing as inflation, but either they do not believe in it, or feel that it is some strange phenomenon that only happens in foreign countries. This lack of knowledge of the subject extends into the highest places, so that in discussing these remarks later, you may find the president or executive of a large bank or corporation, or an extremely successful business man, disagree due to lack of knowledge of the subject.

There are only two ways that you and I can know anything. One is through our own personal experience. This generation in the United States has had no personal experience with artificial inflation, there having been only two in-

stances in our history—once after the Revolutionary War when Continental currency became worthless, and again after the Civil War, when \$300,000,000.00 worth of greenbacks were issued. It took this country seventeen years to recover from this injection of paper money. The only other way we can know anything is through the past experience of others, or the history of inflation, which dates back to the first money.

It would be wise and profitable for every business man to take a couple of months from his business and study the subject, but he refuses to take the time. When I have finished this subject, most of you will still not believe me, but I ask you to remember that there never has been a government debt paid in the history of the world. Some have been refunded or temporarily reduced, but ultimately every nation has increased its debt to a point beyond the taxing power of the nation to service it, and then they have to do the same thing that you and I do—go through bankruptcy and reorganization. This they do by inflation or depreciation of the money, which is the course of least resistance.

I will first outline the pattern and methods of inflation and then discuss it in relation to your particular problems. As I stated before, my remarks will not be personal opinions, but simply interpretation of the history of inflation, and if I seem to criticize the administration, it is purely from an economic point of view and not political.

*An address delivered at the recent convention in San Francisco of the State Association of California Architects.

There are three kinds of inflation—two artificial and one natural. I will first explain the artificial types. In order to understand the subject, it is extremely important that you understand exchange value. This differs from value in use. Air is the most valuable thing that we have because we could not live without it, but it has no exchange value because it is free and requires no human effort to produce. In simple words, exchange value is labor or cost of production through human effort. If it takes one Indian squaw three hours to gather six baskets of berries, and another Indian squaw three hours to collect one-half a cord of wood, then these two products will exchange equally because they both have required the same amount of human effort to produce. But, if the first Indian squaw could collect the berries in one hour, then the second squaw certainly will not exchange three hours' labor in wood for the berries. She will keep the wood and go out and collect the berries herself. Similarly, all products and commodities in trade possess exchange values in relation to the amount of effort required to produce. Don't confuse this with price changes resulting from maladjustment of distribution or supply and demand, which may cause prices to vary temporarily from exchange value, but remember that exchange value is the fundamental basis. In primitive civilization such as I have just discussed, we find that it required at least twice as much effort to exchange as it did to produce. It would take the Indian squaw at least twice as much effort to exchange the wood for food, clothing, and other necessities as to produce it. The reason for this is that in primitive barter there was no **measure** of exchange value to gage the relative amounts of human effort required to produce.

There are two things to consider about measures—in the first place, you must have measure in order to measure. If you were to write "YARD" on a piece of paper and attempt to use it as a unit of measure on plans or on a building, you would find it impossible. You must actually have a yard to measure. Similarly, to measure exchange value, you must have exchange value. It is impossible to write

"EXCHANGE VALUE" on a piece of paper and use it successfully. You must have some commodity that requires human effort to produce, thus investing it with exchange value. Secondly, our measures in the bureau of weights and standards are accurate for practical purposes although not scientifically. However, it has been impossible to find a commodity possessing exchange value that is as accurate as our ordinary measures. Lacking this, we must get as near to it as possible; for, in the absence of an accurate 36 inch yardstick, it is certainly better to use one that fluctuates between 35 inches and 37 inches than one which is 25 inches one week, 30 inches the next, and 35 inches the next. For this and other reasons, gold became the world money. This was not through any mutual agreement between governments, but simply because it possessed exchange value and fluctuated less in exchange value than any other commodity in existence. The reason for this is that the amount of gold produced each year is so small in relation to the total amount in existence that the fluctuation in the cost of production (taxes, wages, machinery, etc.) of the relatively small annual production affects the total amount in existence to a very small degree and slowly over a long period of time. In answer to the statement sometimes made that the world may abandon gold as a measure of exchange value—you can be certain that this will not be done until some commodity is discovered which fluctuates less in exchange value than gold.

In early transactions, it was necessary to weigh and test the fineness of the metal. As this became increasingly inconvenient, it became customary for governments to take a certain weight and fineness of gold in the form of a coin and put a stamp on it guaranteeing the quantity and quality, thus developing the first illusion about money. People thought the **stamp** was the money; however, if the stamp were removed from the gold, it will still possess the same amount of exchange value as gold bullion, so that the stamp adds no value except its guarantee of weight and fineness. Having a coin, it was then necessary to give it a name, thereby developing the second illusion

about money, that the name is the money; but it is only the name of a certain weight of gold. Various countries used different terms, but the basis of all foreign exchange is the amount of gold back of the name. In Germany, before the World War, one mark was the name of 1/80 of an ounce of gold. In this country, one dollar was the name of 1/20 of an ounce of gold. Four marks exchanged for one dollar, because 4/80 of an ounce of gold were equal to 1/20. As gold was easily lost or stolen and transactions and commerce increased in size, large quantities of gold were too bulky to handle and gradually gravitated to treasuries or government warehouses against which were issued warehouse receipts, which have the more popular name of "currency."

Having given you a brief explanation of the evolution of money, I will now give you a simple example of the first of the two types of artificial inflation, which is devaluation or reduction of the metallic content back of the currency. If you have a house that you want to sell for \$10,000 and I have a warehouse receipt for 10,000 bushels of wheat in storage—assuming the wheat to be worth \$1 a bushel—you would be willing to swap your house for my warehouse receipt, as they both possess approximately the same amount of exchange value. However, while we are talking, the warehouse man, being in debt, takes one-half of my wheat out of the warehouse, sells it and spends the money. If a warehouse man did that, I would put him in jail, but if a government does it, you can't put a government in jail. As long as you and I are not aware of his action, we are willing to swap, but as soon as we find it out, you are not going to make the trade. However, you say to me, "If you'll get another warehouse receipt for 10,000 bushels of wheat on the same warehouse with 5,000 bushels of wheat back of it, so that you have two warehouse receipts totaling the original 10,000 bushels of wheat, I will swap." Now, if you have a house that you want to sell for \$10,000 and I have 10,000 warehouse receipts each calling for 1/20 of an ounce of gold, or a total of 500 ounces of gold, you are willing to trade, as you can transfer the exchange value

in your house into the exchange value in the gold. However, while we are talking, the government comes along and takes away 40 per cent of the gold out of the warehouse and spends it for its own purposes.

For simplicity of illustration, and because before we are again able to get gold for warehouse receipts the government will probably get another 10 per cent or more, I am going to assume that they have taken one-half of the gold from behind the warehouse receipt. Now, I know this has been done, and I am telling you, but the important thing is when the majority of the people or the masses will understand it. When they do, you will refuse to trade your house for my warehouse receipts but will say, "If you will get another 10,000 warehouse receipts, each calling for 1/40 of an ounce of gold, thus having 20,000 warehouse receipts with the original 500 ounces of gold back of them, I'll make the trade." In other words—expressed in common parlance—prices have doubled.

We went off the gold standard in the spring of 1933 and the government appropriated 40 per cent of the gold in the warehouse in January of 1934. Your first thought may be that this should have resulted immediately in a price advance of 60 per cent. However, the history of inflation tells us that there is always a lapse of time between cause and effect. Force exerted through an inflexible means of transmission registers immediately; but if I throw a stone into the middle of a pond, the force of displacement does not register immediately on the shore, as there is a lapse of time for the wave to pass through the flexible medium of transmission and reach the shore. The mass human mind is a flexible medium of transmission and it takes time for the action to register in price. It also takes time to dispel the illusion in the minds of the public that the stamp on the coin, the name of the unit, or the warehouse receipt are the money and realize that the only money is the gold back of these. The average time required for this to register is from seven to thirteen years. The only exception is where world conditions—as in the comparatively recent case of Belgium and France—

forced the government to devalue twice in one generation. Then the public, having been through this bankruptcy already, understand it and it registers in price in twenty-four hours. This immediate price adjustment took place in the two countries mentioned, but we did the same thing four and one-half years ago and it has not registered in this country yet because the public do not understand it; but they will in due course of time, as it has never failed to register in the history of money.

What can you do about this for yourselves and your clients? The important problem is to maintain intact the exchange value of your life savings. Naturally, if gold as a storehouse of exchange value fluctuates less in exchange than any other commodity, this would be the safest haven; however, it is a crime to own gold in this country. Next, we think of savings accounts, government bonds, etc., but we find that these are all contracts payable in a fixed number of warehouse receipts, which you already know are to be redeemed at only 60 per cent of their face value, or possibly less, consequently this would be one of the poorest places to conserve exchange value. Lacking gold, we must turn to the next best storehouse of exchange value which—while not perfect—is far safer than paper, and that is property or goods. Expressed in simple, concise language, you should sell or get rid of cash in the bank, bonds and preferred stocks (if not convertible into common stocks), mortgages, annuities and cash surrender in life insurance, and buy with or re-invest the proceeds in real estate—which is the field in which you are particularly interested—commodities, or common stocks representing ownership of American business.

I will take only a short time to explain to you the other artificial form of inflation. I told you that gold accumulated in government treasuries or warehouses and warehouse receipts were issued against it. Supposing we have a government treasury with a certain number of units of gold against which are issued an equal number of warehouse receipts. Now, it was found in the past that these warehouse receipts exchanged at their face value in relation to the exchange value in the gold be-

hind them, and that very few people ever brought their receipts to the warehouse and asked for the gold. Now, a government found itself with insufficient income to pay expenses and an inability to raise taxes, and someone suggested that since very few people ever presented their warehouse receipts to exchange for gold, they might issue more warehouse receipts than there was gold. It was tried, and to their surprise, it worked. Another emergency arose and more warehouse receipts were issued; then bonds were issued—which are only additional printing of paper that bear interest and have a maturity. This is known as "over issue of paper," and as long as it is not abused this paper changes hands at its face value. The reason is that it is based upon the credit of the nation. What is credit? It comes from the Latin word "credo," meaning "I believe." What did the people believe? They believed that somewhere, somehow, the government could get the gold to redeem the paper if they demanded it. However, we find that this government announced that warehouse receipts calling for 1/20 of an ounce of gold would hereafter be redeemed by payment of 1/35 of an ounce of gold; that they would not redeem them for 1/35 of an ounce of gold, nor did they know when they would redeem them, and when they did, they might not even pay 1/35 of an ounce of gold. If you had a bond or mortgage coming due next month and the individual or corporation owing the money announced that it was their intention to redeem the \$1,000 bond with a payment of only \$600; that they would not pay it on the day it was due; that they did not know when they would pay it; and when they did, they might even pay less than \$600, how much do you think that you could get for that bond if you tried to sell it to someone else? You would find that it would sell at a substantial discount. Likewise, paper currency always sells at a substantial discount under similar conditions, when the majority of the public understand. But, as in the case of devaluation, it always takes a period of time for this to register in the public mind. It registers immediately in international markets, and when we abandoned gold in 1933, the dollar

dropped in international markets to 63 cents. The government then appropriated 40 per cent of the gold and established a stated price of 59.06. There never has been a case in history where a currency that was irredeemable in gold did not sell at a discount from its stated value.

Up until six or eight months ago, our currency maintained its stated value for this reason. The government took \$2,000,000,000 of the gold appropriated from the warehouse and established a stabilization fund to support the dollar and government bonds, and stabilize foreign exchange. This fund is manipulated by the President and the Secretary of the Treasury, with no responsibility to Congress or the public as to its disposition. The history of all stabilization funds is that they are eventually cleaned out by world speculators, and the price they are supposed to maintain drops to lower levels than otherwise would be the case. I don't know how much of this stabilization fund is left, but I do know that earlier in the year, when the price of gold advanced to \$35.23 an ounce in the free-gold market in London, compared with an export price of \$34.74, this represented a drop in the American dollar to 58½ cents. It has since been supported, but as soon as the stabilization fund is depleted, it will follow the way of all other irredeemable currencies and again decline in price below its stated value. How far this will go, it is impossible to predict, as there is no way of telling how far a nation will go along the road of inflation once it has started on that one-way street from which there is no turning back. Our estimate—which is concurred in by some of the leading economists—is that it will sell at a discount equivalent to 20 to 25 cents.

I will only spend a few minutes on the subject of natural inflation, which dates back to the "seven lean years and seven fat years," and probably further if our records were complete, and is commonly known as the business cycle. It is a reflection of mass psychology. Man is governed 5 per cent by his intelligence and 95 per cent by his emotions. It is human nature for him to be happy and sad; elated and dejected; optimistic and pessimistic, and, because of his "herd instinct," or that desire to

do what the majority of his fellow men are doing, we all reach these extremes at about the same time. All through history, economic panaceas have been proposed, promises made and laws passed in an attempt to level out the "hills and valleys." But until such time as laws may be passed regulating human nature, or until we abandon the capitalistic system, we will continue to have booms and depressions. My time does not permit discussing this as extensively as I would like to do. I can simply say to you that we are in a period of natural recovery from the depression low of 1932; and that our so-called "depression number two" was a relapse back into depression number one, caused by the registration of inflation. This registration passes through five stages, which time does not permit explaining, but we are at present in the middle—or fear psychology stage—which is always accompanied by violent up and down movements in prices. We have had our first sharp decline and are well on the way of the upward move. This may pass into the explosive stage of inflation, or we may have further declines from higher levels and more government printing of paper before this active stage. The explosive stage will be reached when the illusion about money is dispelled in the minds of the public and in an endeavor to keep intact the exchange value of their life savings, they all try to get out of pieces of paper or warehouse receipts into commodities, real estate, or common stocks at the same time. You can well imagine what will happen when 130,000,000 people all try to get rid of their money at the same time in exchange for goods.

Now I will apply this to your particular problems. We are in natural recovery following the bottom of a depression, and on top of this, we must make the necessary adjustments for the two kinds of artificial inflation representing our present governmental monetary policy. I will first give you some idea as to what will happen to prices in terms of the depreciating money, and then tell you how you can use this to your advantage immediately. If you own a piece of property that would sell for \$25,000 today, which is the equivalent of 1,250 ounces of gold in exchange value in the old dollar, this would

probably, through natural recovery into prosperity, advance to conservatively \$40,000, but in order to be more conservative and not frighten you by seemingly fantastic figures, I will eliminate any consideration of price advance through natural recovery. I have shown you that through devaluation of the currency, making warehouse receipts formerly redeemable with 1/20 of an ounce of gold redeemable with only 1/40 of an ounce of gold, we will have to have twice as many warehouse receipts. This makes the price of your property \$50,000 and does not alter the exchange value, as the \$50,000 will only call for the same 1,250 ounces of gold. I have also shown you that in the process of inflation and before you can again get the gold, these paper units always sell at substantial discounts from their stated value. Making allowance for the probable discount that will obtain in this country (25 cent dollar) we would again have to double the number of currency units, thus raising the price of the property to \$100,000. This figure may sound fantastic, but please remember that the price levels reached in Germany, France and

Italy sounded equally as fantastic to the public when they were at the same stage of the registration of inflation that we are in today. Naturally, the stampede into property and the resulting price advance will bring about a tremendous increase in building activity, which will mean much greater profits to all of you, whether you understand it or not.

However, you can do something very constructive about this at the present time. If you will learn enough about the subject that I have explained, through study or contact with others who have studied, to present it to your own clients and prospects as a business argument to maintain the exchange value of their savings by disposing of cash, bonds, mortgages, and all other instruments payable in a fixed number of currency units, or having a fixed income payable in these units, and go into real estate and building, you will not only increase your own volume of business and profits, but your advice will be so sound and profitable that you will probably never lose them as clients and friends.

Beautiful

*Modern Architecture can be made
pleasing to the eye*

TRUE functionalism in architecture can be effectively combined with an expression of emotional feeling, according to Dr. Paul Zucker, professor of the history of architecture at Cooper Union. The public has been misled in the understanding of modern architecture, declares Dr. Zucker, for many years a prominent practicing architect in Germany, and former dean of the faculty of fine arts in the University of Lessing, Berlin.

"Contrary to the popular impression," he says, "modern architecture, which makes a completely useful building with a minimum waste of space, can be combined with the expression of an emotional feeling. Modern architecture can also be pleasing to the eye despite the notion that buildings of modern design are constructed to please the mathematical calculations of the engineer."

Citing the work of Cooper Union students

in a competition for the design of a memorial lighthouse which was won by Helmut Riehl of South Orange, N. J., Dr. Zucker states that the students have succeeded in doing with modern architecture what many experienced architects and designers have failed to do. Each of the entrants, he points out, combined functionalism and emotionalism.

Modern architecture with its simple, straight lines, flat surfaces, and lack of ornamentation governed the twenty-eight designs submitted. Not a single entry showed the lighthouse in a circular shape, a form associated with lighthouses for centuries.

In a statement outlining the objective of the competition, the competitors were told by Esmond Shaw, assistant art director at Cooper Union, that "a democracy which has survived the totalitarian craze of the years 1920-1950 wishes to build a war memorial to its sailors who died in the great naval engagement which finally proved the superiority of the battleship over the airplane."

"The battle," the preamble of the problem set forth, "took place some 300 miles at sea off the harbor of the nation's greatest city. At the mouth of the harbor is a small island, 500 feet long, 250 feet wide, and 50 feet high, roughly crescent-shaped, with the concave side facing the land and the convex side the sea.

"On the island is an obsolete lighthouse. The local legislature has decided that a new lighthouse shall be erected that will be part of the war memorial."

Specifying the use of concrete throughout, Riehl designed his tower as an open square at the base. He provided for two supporting fins tapering upward to form a support for the light which faces the open sea and is capable of throwing a fifty-mile beam. The light also serves as an airplane beacon.

Dr. Zucker explains that the fins, which make the structure a three-sided one, do not detract from the tower's strength. An elevator and stairway to the tower is provided in one corner of the tower with a minimum waste of space.

Perfectly related and blended with the light-

house tower, is a combination memorial chapel and mausoleum which stands proximate to the tower and is built with a series of parabolic arches. Light is admitted into the interior through glass, which has been substituted for the concrete slab between the second and third arches. Horizontal steel members web the framework to support the arches.

A long uphill concrete walk marks the approach to the chapel, while concrete walks surround both the chapel building and the lighthouse tower. A cantilever reinforced concrete canopy is suspended over the glass-door entrance to the chapel. Living quarters for the lighthouse keeper and other employees, are incorporated in a two-story glass-enclosed building under the base of the lighthouse tower. On the lee side of the island, Riehl has designed a landing stage, large enough to accommodate supply ships and excursion steamers up to 200 feet in length.

"Mr. Riehl's design proves many significant facts," says Dr. Zucker. "It is completely functional and develops an artistic form beyond more calculated construction. The main idea is use of parabolic concrete arches and from there the whole form is developed. The lines of the building appear very clearly because there is no separation between walls and roof and no interruption of any kind.

"Without doubt the artist was influenced by the famous airship hangar built in France fifteen years ago from a design by the artist Freyssinet. Mr. Riehl did more than Freyssinet because he was able to express the emotional purpose of the monument by connecting the chapel and the tower. On one hand, the tower serves the purpose of supporting the light, and on the other hand, it is pure form and expression for a momentous feeling like an exclamation mark.

"The development of the tower, stretched between two slices of concrete which are as thin as the material allows, is very cleverly done. The solution is, indeed, remarkable because while it is really quite modern in its construction, the artist develops his own very expressive form."



Photo by Moulin

FACADE, SCOTTISH RITE TEMPLE, OAKLAND, CALIFORNIA
WILL G. CORLETT, ARCHITECT



DETAIL OF FRIEZE OVER COLONNADE, SCOTTISH RITE TEMPLE, OAKLAND

Remodelled

*Scottish Rite Temple, Oakland, California
has a new dress*

THE picture on the opposite page is a striking view of the facade of the reconstructed Scottish Rite Temple in Oakland, Will G. Corlett, architect. In architectural harmony with the main mass of the building, the new front reflects the dignity and character becoming to a building of this type.

The improvements involved the removal of the old facing and brick backing, brick fireproofing, some concrete fireproofing (for the attachment of anchors) and the constant protection of interior finish, furring and plaster close to the walls. Due to the necessity of working entirely from the outside, difficulties of both design and execution had to be overcome.

The design was carried out in poured concrete with no precast work or exterior plaster coats. Accurate, careful and thoroughly tied and braced framework was done with smooth plywood up to the fourth floor level and T&G end-matched forms above the fourth floor level combined with plaster waste moulds for ornamental work.

The forms had to be built backwards, that is, the inside form was built first, moved into place and the outside form built last. Placing form clamps and ties was difficult because of the inaccessibility of the back of the forms. Twenty-eight different pours were necessary.

The facade is 110 feet high, the central motif 89 feet wide, the total width of the building being 154 feet. The columns are five feet two inches in diameter and 42 feet high. The figure panel, shown in detail above, is 56 feet long and the figures are 15 feet high. The plaster waste moulds for the panel were in 18 pieces, weighing when dry about 900 pounds each. All eighteen pieces forming the whole panel were erected before pouring any of the panel. The face of the figures is flush with the wall surface and the maximum incision depth of the modeling is five and one half inches.

The entire facade was brush coated with a waterproof white cement wash, followed immediately with a fine dash.

Favorable Outlook

Residential construction already up 35 per cent

says Fred'k H. Meyer

While the national trend in building during 1938 showed an encouraging upward tendency, the longer term outlook will be shaped by basic social and economic conditions, according to Frederick H. Meyer, architect of San Francisco and vice president of the American Institute of Architects. Continuance of the upswing is seen by Mr. Meyer, who summarizes the current situation as follows:

THE trend of the building cycle is definitely improving, and is following the usual pattern. The first stimulation, namely, alterations and repairs of buildings, has reached its peak, and is on the descending curve. The second phase, residential, is following a steadily upward trend, and promises to continue. All classifications of buildings, except alterations and repairs, are improving, with further progress indicated.

The construction of schools, hospitals, and buildings of like character is showing rapid gains. Commercial buildings, factories and manufacturing plants are still at the bottom of the cycle, and await the stimulation of buyer demand. The building industry should be encouraged by the improved labor conditions, the stabilization of material price structure, and the renewed confidence of the building public.

Reports available for the ten months of 1938 indicate that while in the country at large the total value of building permits is practically the same as a year ago, the number is about one-fifth greater, which is directly attributable to the acceleration in the residential classification.

RESIDENTIAL BUILDING UP

There was an increase in the building of the nation of 8.6 per cent in October over the same month in 1937. Residential building was up 35.4 per cent but non-residential building was off 4 per cent and alterations and repairs were off 20 per cent.

Conditions, in the light of these statistics, are not abnormal. It is well to remember that the first effort of the Government in its admirable plan to stimulate the building industry was, first, to encourage home owners and building owners to improve, repair, paint and powder their buildings and to help finance these improvements through reasonable Government insured loans on the easy payment plan.

San Francisco alone started and completed more than \$11,000,000 in alterations and improvements to existing buildings in a single year. This program reached its peak in the early part of 1938 and will continue to decline and is now off 20 per cent in a single year.

FEDERAL PROGRAM AT PEAK

The second phase of the Government program, new home building, is now in full swing, stimulated by bank loans, a sound financial plan of Government-insured loans at a reasonable interest rate, and monthly payments of principal and interest kept within the budget of the borrower. Judging by the eagerness with which the public has grasped this opportunity, the program is constructive. The result shows that residential building is up 35 per cent. San Francisco alone during the first ten months of 1938 built 1,650 new single-family homes, or enough to make an unbroken line of new dwellings eight miles long, cost-

for 1939 Building

*U. S. Housing Authority
expects an 80,000
dwelling increase*

More than 20,000 low-income families who formerly dwelt in slum tenements and shacks today are residing in decent, safe and sanitary living quarters in public housing projects administered by the United States Housing Authority, according to a year-end recapitulation by Nathan Straus, USHA Administrator. In 1939 thousands more will migrate from the slums into decent low-rent homes. Mr. Straus says:

AT PRESENT, twelve large low-rent housing projects to provide about 9,000 new homes, are under construction contracts and this year it is estimated that work will be started on between 75,000 and 80,000 additional homes.

This building program will provide millions of man-hours of labor for a veritable army of workers and will provide new homes for thousands of underprivileged families whose average annual incomes will range from \$1,100 down to \$450 a year. Shelter rentals in the new projects will range from \$8 per month for a dwelling unit in the South to \$20 per month in the larger industrial cities.

Increase in the number of local housing authorities during the year just closed indicates the enthusiasm with which the National slum-clearance and rehousing program is being received from coast to coast.

A year ago, there were 46 local public housing agencies; today there are 221.

To date, 140 low-rent housing projects in 73 cities and two counties in 22 States, the District of Columbia and the Territory of Hawaii, are under contract for USHA loans totaling \$320,986,000. These loans represent 90 per cent of the cost of the projects. In addition, 123 communities have received earmarkings of \$328,803,000, making a grand total of \$649,789,000 so far committed by the USHA.

ALL USHA FUNDS ALLOTTED

The demand of local housing authorities

for USHA financial aid in clearing their slums and rehousing families of low income has been so great that all USHA loan funds have been committed and there is great unfilled demand for more funds and more projects.

CONSTRUCTION CONTRACTS TO DATE

To date construction contracts have been approved totaling \$28,964,621 for 12 projects.

The following data is based upon the total estimated development costs of the 12 projects for which the greater portion of the construction work has been approved:

Total Estimated Development Cost	\$45,384,201
Number of Dwelling Units	8,956
Funds to be Expended for Materials	\$15,967,523
Funds to be Paid in Direct Wages to Workers on Site	\$13,227,500
Man-hours of Labor Directly on the Site	12,109,200
Man-hours of "Behind the Scenes" Labor off the Site	18,164,100
Man-hours of Direct Labor both on and off the Site	30,273,300
Total Number of Men to be Employed during Construction	10,085

(Please turn to Page 45)

RESIDENCE CONSTRUCTION UP

(Concluded from Page 42)

ing about \$8,000,000, as compared with 440 homes in 1933.

Reports on construction east of the Rockies for the ten months of 1938 compared with the same period last year show the total number of projects to be up 18.2 per cent. In the residential classification, the number of permits was up 25.7 per cent. In the non-residential classification, the floor area was off 20 per cent, and the valuation off 15.9 per cent.

Reports on all building west of the Rockies for the ten months of 1938 show valuations up 0.6 per cent over 1937, 10.3 per cent over 1936, and 98 per cent over 1935. The residential classification valuation for the ten months of 1938 gained 10.5 per cent over 1937 and 36.5 per cent over 1936, and was the highest for any similar period in eight years. Reports from eighteen cities in the Far West show that the value of residential permits for the ten-month period of 1938 was greater than the combined total for the four full years of 1932, 1933, 1934, and 1935.

Building reports on California cities for the ten months show the total value was up 3.1 per cent over 1937 and 11.2 per cent over 1936, while the value of residential building was at the best level in eight years with a gain of 11.3 per cent over 1937 and 34 per cent over 1936.

Reports on the combined building in San Francisco and Oakland during the ten months show the total number of permits was 15.9 per cent above the same period in 1937, but the valuation was 2.2 per cent under a year ago. The number of residential permits was up 22.1 per cent and the valuation 19 per cent. Non-residential construction was off 17.6 per cent.

From the above, it is quite apparent that the San Francisco Bay Area, California and the Far West, have been making great strides recently in residential construction. This is the first sign of a general building recovery.

Under the stimulation of the P.W.A. and the vast Federal grants made to towns, cities and states, communities have anticipated their needs for schools and other buildings and public works and have been crowding to completion a vast area of new covered space, giving employment to a large number of architects, draftsmen, contractors and mechanics, using millions of dollars worth of building materials, and thus pushing ahead the second phase of building recovery by this plan of Government stimulation. The wisdom of this plan is yet to be proved. Perhaps it would have been better if the time could have been extended over a longer period.

IMPROVING SLUM AREAS

The program of the United States Housing Authority is now well under way, and in anticipation of clearing away slum areas many cities have "earmarked" millions of dollars for local use. The local authorities are slowly breaking down the resistance against Government subsidized housing and are gradually getting under way.

This third phase of the building program will carry the housing boom well past the anticipated peak and decline of single-family housing, and should have the effect of stimulating large scale housing programs by private capital. This will, I feel sure, revolutionize the general conception of mass housing, with full consideration given to proper site plan, garden areas, play areas, light and sun, and will offer an example and perhaps a solution in the prevention of "blighted areas" caused primarily by the greed of the sub-divider, the crowding together of houses, and the ill-advised and senseless land coverage, poor building material, and poor planning.

It is plain to those who have investigated and studied the present Government program of slum clearance and low rental housing that the very financial structure requires assurance that tenants must be able to pay their rent. The vast number of

poor who occupy the sub-standard slum housing, who cannot be considered good rental risk, and the millions of industrial workers must be cared for by some other plan and it is inevitable that the effort to meet this need must be made by industry itself.

MASS PRODUCTION FAVORED

I believe the solution can be met only in one way—by applying the principles of mass production, so successful in the manufacture of automobiles, to ready-made unit houses capable of being expanded into two, three, four or five rooms by simply adding ready-made units, constructed undoubtedly of steel in some new rustresisting form and made available at low cost.

It is interesting to note that Walter McCornack, architect of Cleveland and chairman of the Housing Committee of the American Institute of Architects, has already anticipated the need and probable demand, and has attacked the problem with his usual practical and commonsense approach, and I am confident he will succeed in persuading industry to recognize the opportunity and make a start, experimental perhaps, in the production of housing units that will meet the demand for low cost, low rental, decent, sanitary housing, for which there is a demand.

No single unit of the building industry alone can succeed in such an experiment; it must be the result of the cooperative effort of many producers of building materials.

FEDERAL HOUSING

(Concluded from Page 43)

Among the many important accomplishments of the USHA are analytical and businesslike breakdowns of all factors in costs. Without this there can be no rational comparison between the cost of public housing and the cost of private housing because the "total" cost of a public hous-

ing project includes items which are practically never included in the cost of private housing.

COST OF SLUM RIDDANCE

One item of primary importance is the cost of slum buildings to be purchased and torn down. This represents an expenditure, not to create new housing for slum dwellers, but rather to rid a city of rotten buildings which are a blight upon its surface and a drain upon its resources.

This admittedly desirable undertaking, while it enters into the total cost of a public housing project, does not enter into the total cost of a private housing venture simply because the speculative builder practically never performs the function of slum clearance—and, incidentally, that is why we have so many slums.

A public housing development goes beyond the narrower objectives of a real estate venture and seeks to integrate a new housing development into the life of the city as a whole. In a public housing project the walls, the floor and the ceilings do not constitute the whole job. Playgrounds, air and sunshine, neighborhood improvement, and the removal of slums and blight, all are included in the public benefits conferred upon the community.

The estimated net construction costs per family dwelling unit for USHA-assisted projects are computed upon a basis of items identical with the items entering into the net construction costs for private construction shown in the building permit data collected and tabulated by the Bureau of Labor Statistics of the United States Department of Labor.

The Bureau of Labor Statistics figures for the first ten months of 1938 show that the average net construction costs on private dwellings ran considerably higher than the estimated costs on USHA public housing projects.

TWO INTERESTING CALIFORNIA HOUSES



RESIDENCE OF MR. AND MRS. HANS VON GELDERN, ST. FRANCIS WOOD, SAN FRANCISCO

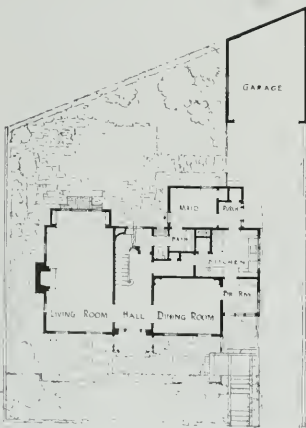

PLOT AND FIRST FLOOR PLAN

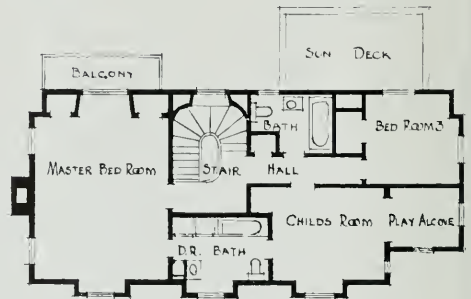

SECOND FLOOR PLAN

DESIGNED BY LAWRENCE A. KRUSE, ARCHITECT

Photos by L. C. Bringer



RESIDENCE OF MR. AND MRS. HARLEY LEWIS HOOPER, MILL VALLEY



FIRST FLOOR PLAN



DETAIL OF LIVING ROOM



GARDEN VIEW, HOUSE FOR DR. IAN CAMPBELL, PASADENA, CALIFORNIA
Erle Webster and Adrian Wilson, Architects

THE roofed terrace which opens off the combination living-dining room faces a private garden area entirely separated from the street. The band of windows and glazed doors which open on to the terrace serves to make this outdoors living area a part of the rooms within.

The second floor areas also open out to a deck overlooking the garden.

The L-shaped combination living-dining room shown on the opposite page was designed to give the greatest possible spaciousness in a small area by emphasizing the long diagonal dimension of the combined spaces. The dining table and the fireplace-sofa unit are at opposite ends of this diagonal, thus establishing it as the major axis of the room. The floor and ceiling extend through in unbroken planes and the curtain which can be used to divide the areas while setting or clearing the table is hung from a small metal track at the ceiling.

The design and placing of the dining table, which was specially made from Miss Easton's sketches, also adds to the roomy effect by leaving clear floor space where it is most needed. For the family group the table is against the wall or in the corner while for a party of eight the table is moved out and expanded to a square seating two on each side. The flexibility and informality of these seating arrangements avoid the stiffness of the usual dining room, except when the curtain is drawn. Table and benches are natural maple and birch upholstered in tan Fabricoid.

Most of the furniture was designed and built as a part of the house. At the left of the fireplace are built-in bookshelves and a desk; to the right of the desk a cabinet, for firewood which is filled from the outside. To the right of the fireplace is a built-in radio and clock and a couch flanked by built-in end tables.



LIVING ROOM, HOUSE FOR DR. IAN CAMPBELL, PASADENA, CALIFORNIA
 Erle Webster and Adrian Wilson, Architects
 Honor Easton, Interior Decorator

Competitions

A. I. A. stamps its disapproval of promotional affairs

THE following statement explains the American Institute of Architects' attitude with respect to promotional competitions:

"The American Institute of Architects, realizing that the competitive selection of an architect was a method long established and of undoubted permanency, decided some thirty years ago to assume control of competitions for the protection of their members, of the owner, and of the profession at large; and to that end formulated certain methods of procedure mandatory for their own members, as The Institute naturally cannot assume to dictate an owner's course in the conduct of a competition.

"An exception to these established methods was made in the case of competitions held by Architectural Schools and similar institutions,

which were termed educational in character.

"By degrees the term Educational was stretched to and beyond its limits. Competitions began to be held by manufacturers, material dealers, and the like, which were at first approved by the Committee on Architectural Competitions because they did not lead to the erection of any actual structure, and because the prizes offered were an incentive to the younger members of the profession.

"This early approval was later modified by a ruling that it was not the policy of The Institute to grant its official approval to competitions of this type, but that participation of their members was not denied, either as Competitor, Jury member, or as Professional Adviser.

"But advantage has been taken of this liberal

attitude of The Institute by the holding of open competitions to bolster the raising of funds for possibly worthy but vague semi-public propositions; these competitions being based on the exemption from Code requirements under the term Educational. In some cases there have been definite stipulations that the winner would be appointed architect if and when sufficient funds were raised, but often the only incentive was the generally insufficient prize money offered. And of late there has been a tendency on the part of architectural magazines to sponsor and conduct these competitions.

"The Institute authorities are seriously considering whether or not the interests of the profession would be better served by their complete disassociation from all competitions that do not lead directly to the erection of any actual structure. They are hesitant to take any step that would deprive the younger members of the profession of the experience they might gain and the prizes they might capture in the simpler type of competition promoted for its advertising possibilities by those financially interested in the building trades; by magazines offering prizes for housing or other developments; or by institutions for purely altruistic purposes: For although few Institute members enter these competitions as competitors, it is the custom of their proponents to appoint, as Professional Advisers and Jury, well-known architects for the prestige of their names, and such appointment would be prevented if The Institute withdrew the qualified approval they now give.

"It may be that means will be found to meet this condition by the formation of a subordinate class of competition, held under the strict control of The Institute; but it can be stated definitely that The Institute does not look with favor on competitions held mainly for publicity in the hope of raising funds for vague operations that may never materialize, and for which there is no definite assurance of a future contract; nor upon competitions that do not provide for full architectural services; nor do they approve the action of architectural magazines in sponsoring or conducting architectural competitions, con-

sidering this an intrusion on the rights of the profession to conduct and be responsible for their own operations, and as prejudicial to the interests of The Institute and of the profession at large.

"This attitude of The Institute, for some time under consideration, was finally determined by the methods adopted by the proponents of three important competitions recently held. In the case of the two first, the approval of The Institute was sought through Sub-Committees on Architectural Competitions, and after certain changes in the program, this approval was reluctantly granted. In the third case, a competition for a 'Festival Theatre and Fine Arts Building' at the College of William and Mary in Williamsburg, Va., The Institute's approval was not sought, though there was implication in the program that being Educational in character, it had the quasi approval of The Institute, an approval that it could not have secured.

"The Institute authorities here express their disapproval of this competition and deny the participancy of their members in jury service, but do not deny participancy as competitors, this exception being made because of the late issuance of this order.

"The Committee on Architectural Competitions views with increasing concern the cost to competitors in the mandatory submission of unnecessary drawings, and has decided to instruct the Sub-Committees to insist upon the reduction to a minimum of the number of drawings, and upon their simplicity of presentation; and will recommend that The Institute issue for the information of those concerned a revised and simplified Circular of Information.

"The Committee takes this opportunity to call again to the attention of all Professional Advisers and Sub-Committees the necessity of reporting promptly to this Committee, or to The Octagon, all details of competitions in which they are concerned.

"There is also under consideration the necessary indication of Institute approval by the adoption of a special form of cover for competition programs, suitably inscribed, or by the affixing of a conspicuous seal upon the cover or front page of the program."

Versatility

The Engineer—Plus

by John C. Page

WE ARE in a new day which opens many broad opportunities to the engineer, but before he can seize them he must be an engineer plus.

He must be an engineer as adept as ever with his slide rule, his transit and his blueprints, but he needs additional qualifications of leadership and broad social knowledge to assume the place which may be his in this new era which will emphasize conservation. It is as important to the nation as to the engineering profession that we develop these engineers with something more than technical knowledge and skill. It is important because all branches of the conservation movement need trained engineers, with vision, to assist in or to take the lead in carrying out the rebuilding programs which must be launched.

Conservation is not a political issue; it draws its supporters from all parties and all walks of life. Introduction of a comprehensive conservation program at this time means that we are turning our backs upon the practice of exploiting our national resources for temporary and immediate gain without regard for the future. It means that we have substituted, rather, a policy of husbanding our resources in a manner which will result in their broad and most beneficial use in our generation, and yet will preserve their usefulness for future generations.

Without leadership, nothing permanent can be accomplished. That is why it is so important that the engineering profession develop understanding leaders. Without a broad and general understanding of the problems involved, the

mass support which is necessary to any fundamental change in policy cannot be generated. That is where the floods, the droughts and the dust storms have played so great a part.

Although these lessons, administered by Mother Nature to us, her children, have been painful and costly in the extreme, they have served to bring home to almost every individual in the United States the fact that he has a personal interest in the success of a well-rounded and intelligently applied conservation program.

Soil and water are our two primary resources. It took the terrible droughts in the Great Plains of 1934 and 1936 and the unprecedented floods in the Ohio and New England valleys and in California to make everyone aware of the fact that our soil and our water needed protection, else their usefulness at least might be destroyed. All other forms of conservation are related to these two and, moreover, the conservation of soil and the conservation of water are inseparably joined together. It would be shortsighted, therefore, to sponsor a program which embraced but a single link in the whole interconnected chain.

It has been a comparatively short time since the conservationists were divided into small camps, each battling under its own standard for preservation and protection of wild water fowl, of our native big game species, of the fish in the stream, of our forests and woodlands and of wilderness areas, thus dissipating against a wall of inertia the strength of forces which, combined, might have brought much earlier

the profound changes in national attitudes which are now in progress.

It has been only recently that these various elements have been pooled together by leaders of broader vision.

One of the most significant developments of recent years in this field has been the leadership and the work of the National Resources Committee, which has made studies and important contributions to the advancement of the conservation cause. Its Water Resources Committee has done a pioneering work of great value in assembling information concerning the water problems of every locality in the United States and in the formulation of a planned program for their solution.

Whether the problem is reforestation of mountain slopes, control of erosion in the fertile plateaus, abatement of pollution in the eastern rivers, rehabilitation of the habitat of wild life, irrigation, flood control or any of the others, which must be solved in the conservation of our resources, it involves engineering problems. Work for the engineer is one of the threads which binds all of these together. It obviously is important, therefore, for the engineer to understand these problems and to take the leadership in developing a plan for their solution. It no longer is sufficient for an engineer to know how to build a dam; if he is to fulfill his highest duty, he must know also why the structure is to be built and he should be in a position, as well, to say whether the dam will serve its purpose.

Not long ago a prominent engineer told me that he once worked on the problem of designing a water retention system in the Sierra Nevadas of California for five years before he discovered who expected to build the system and for what purpose the water was wanted. He was merely applying his training and skill to an abstract problem. Under those circumstances his contributions could have been no more than a perfection of the engineering drawings for a dam.

The engineering profession must make its influences felt further than the drafting room, but it cannot unless it applies its thought to social and economic problems and lends its

influence and leadership to their correction.

The Bureau of Reclamation, with which I am connected, has in its charge the execution of one of the great social programs of the country. This organization is peopled largely by engineers. Throughout its long history, the fundamental purposes of the Bureau of Reclamation have been to provide homes for people and to develop the West through the conservation of the meager water resources of this arid and semiarid region.

Much of our work is engineering work, as is indicated by the facts that we have constructed 138 dams and now we are building a score more, and that we have built about 20,000 miles of canals and are building many more long canals at the present time. Certainly the engineer plays a major part in this phase of the conservation program.

Despite the engineer's function here, the value of the Reclamation program is and must be judged by the social and economic results of the construction and not by the construction itself. The significance of the Federal Reclamation program lies in these facts: We have made homes for almost 900,000 persons on 48,773 farms and in 257 towns and cities by the irrigation of about 3,000,000 acres of land in projects scattered throughout the arid West. Using water which otherwise would be wasted, perhaps in destructive floods, upon lands which otherwise must have remained useless desert, these human opportunities have been created. Since this work began in 1902, crops valued at nearly 2½ billions of dollars, or more than ten times the cost of the irrigation works of the projects which now are being operated, have been harvested and marketed by the farmers in these irrigated areas. This means the addition of a tremendous amount of wealth to the country as a whole.

Incidental to the work of irrigating farms, the Bureau of Reclamation has provided on twelve projects power plants which furnish cheap energy to light the rural homes, to run the farm machinery, as well as to operate the pumps and gates of the irrigation system itself. The revenues from this by-product of irrigation assist the water user in repaying the cost of his

construction. This is another important social contribution.

The state and local governments, the schools, churches and other community institutions of wide areas in the West owe their major support to the fact that irrigation projects have been built. In addition, the existence of transcontinental railroads, transcontinental telegraph and telephone systems and of transcontinental highways is largely dependent upon the fact that the great intermountain desert can be bridged on the buttresses formed by irrigation projects.

The livestock industry in the West, its largest, obtains approximately one-half of the feed which supports it from the public ranges and the other half from the irrigated areas, which are mere dots in the landscape.

With so much depending upon the success of the program, its administration is a grave responsibility. The water supply of the western one-third of our country is severely limited. The land resources of that area are so great by comparison that literally hundreds of millions of acres can never be used. Of 700,000,000 acres in the arid and semiarid West, 20,000,000 acres now are developed by irrigation. It is estimated that the remaining unused water resources will irrigate only an additional 10,000,000 acres with projects which can be considered feasible at the present time. Projects now under construction by the Bureau of Reclamation will bring in, on their completion, about one-quarter of the remaining feasibly irrigable lands. The selection of the lands which are to be developed in the future is a serious matter.

From the beginning of Federal Reclamation, administration and execution of this policy has been in the hands of men recruited from the engineering profession. Its achievements to date and the success or failure of the program in the future, to a great extent, will be the responsibility of the nation's engineers. I cite this example because it is one with which I am

familiar and because it serves to emphasize the earlier statement that the engineer must prepare himself as a professional man to take an important part or assume leadership in the conservation of our resources.

The times cry loudly for the engineer with a social conscience, both in the service of the Government and in private practice. Responsibility for many of the programs and much of the rebuilding for conservation of necessity must be accepted by the Federal and local governments. A large proportion of the American engineers is called upon at some time to serve the State. Because of this, if for no other reason, engineers generally ought to know something about the public weal.

He ought to know something about the social and economic problems that we are facing and which we must solve wisely if we are to make our democracy work. An engineer can be just as good an engineer, and perhaps even a better one, if, at the same time, he had a broad social outlook. An engineer not only ought to be competent as to engineering technique, he also ought to know for what purpose and in whose interest he is employing his technique.

Perhaps what I have been saying here boils down into a plea for a more professional approach to engineering; for the elevation of this work from simple craftsmanship, no matter how highly skilled, to a higher plain of professional attainment. I would like to see this end achieved, because I am an engineer and because I am employed by the Government in a conservation activity.

In any event, the opportunity is present for the engineer plus to do a great service to his state and his country. The opportunity is at his elbow, because every locality in the United States has one and most have many more problems crying for solution along sound technical and social lines.

Construction Activity in 1938

Largest Since 1930

CONSTRUCTION activity in the United States in 1938 reached the eight billion mark, the largest total reported in any year since 1930, according to the annual estimate released by the Bureau of Foreign and Domestic Commerce. The total, which includes not only the estimated current expenditure during the year for new construction, but also maintenance and work-relief construction, is an increase over the revised estimates of \$8,675,000,000 for 1937. The increase in 1938 was the result of a gain of \$540,000,000 in public construction, which more than offset the decline in private work. The movements of the preceding year were thus reversed—in 1937 the expansion as compared with 1936 was the result of a substantial increase in private work, while public expenditures for construction projects declined. Although the increase for the year 1938 was the fifth consecutive yearly gain, total expenditures for construction in 1938 were one-fourth less than the average volume during the decade from 1920 to 1929.

There is a considerable variation in the movement of construction volume not indicated in the yearly estimates. While no series is fully adequate to measure construction expenditures in a given month, the indications are that projects were initiated in comparatively large volume during the first half of 1937, continuing the upward movement of the previous three years. Beginning in August and September, 1937, the volume of construction started fell off and continued at lower levels to the end of the year. The recession in construction projects initiated, excepting work-relief projects, continued through the first half of 1938, but in the third quarter the volume of construction work undertaken rose to higher levels than a year earlier, and in the closing months of last year the totals were considerably higher than in 1937. The advance in construction in the latter part of 1938 was the result of a larger volume of public-works projects under the revived program of the Public Works Administration and increased private residential building stimulated by lower building costs and lower interest charges and smaller initial payments required under the amended program of the Federal Housing Administration.

New construction activity, which does not include maintenance and work-relief, declined slightly from \$5,340,000,000 in 1937 to \$5,200,000,000 in 1938; however, it was more than twice the 1933 figure. This category of construction averaged \$9,000,000,000 annually in the ten-year period ending in 1929 and attained a peak of \$10,948,000,000 in 1927. The significance of this loss of nearly \$5,000,000,000 is not fully realized until one considers the effect upon the whole economy

of such an expenditure not only in the industry itself but also upon the attendant industries such as building materials, real estate, transportation, etc. Private residential construction declined in 1938 more than \$100,000,000 to \$1,285,000,000 and constituted but 25 per cent of all new construction as compared with an average of about 40 per cent for the decade of the 1920's. In spite of a decline in dollar volume the number of dwelling units upon which construction was started in 1938 was higher than in any year since 1929 and may attain 360,000 units. This total includes both private and public residential, but the increase is virtually all in the private field. As compared with other recent years residential building in 1938 was improved, but as compared with the years 1920 to 1929 when the annual average number of units reached the high average of 675,000, activity was relatively low.

Primarily as a result of a drop of about one-third in factory building in 1938, total private nonresidential construction declined from \$894,000,000 to \$745,000,000. Public utility companies spent approximately 20 per cent less for new construction in 1938 than in the previous year. Recently improved business conditions have favorably influenced the outlook for this type of construction.

New public construction, excluding Federal work-relief construction, of the Federal Government was \$1,275,000,000 in 1936. The total for 1937 was slightly lower, and in 1938 the total is estimated at \$1,310,000,000. The work-relief construction of the Federal Government under the Works Progress Administration is estimated to be \$1,000,000,000 for 1938, a considerable increase over the preceding year and almost equal to the total expenditure made for the peak year 1936. State and local government construction also increased in 1938 and totaled more than \$1,000,000,000.

INTERNATIONAL CONGRESS OF ARCHITECTS

A. C. Simonpietri, Assistant Secretary of the Organization Committee of the Fifteenth International Congress of Architects, which is to be held in connection with the A. I. A. Convention in Washington this year, has in preparation a brochure which will be sent to the architectural organizations of some sixty nations in an effort to stimulate interest abroad in the Congress.

He states that the purpose of this booklet is by means of photographs of architectural or engineering works to excite the curiosity and interest of foreign architects and engineers and engender a desire for personal inspection. Mr. Simonpietri is interested in receiving such photographs at The Octagon in Washington.

ARCHITECTS' BULLETIN

Issued For

THE STATE ASSOCIATION OF CALIFORNIA ARCHITECTS

Northern Section

STATE ASSOCIATION MEMBER
OF THE
AMERICAN INSTITUTE OF ARCHITECTS

Editor

Harris C. Allen

Address all communications for publication in the Bulletin to the Editor (Harris C. Allen) 557 Market Street, Room 218, San Francisco, California.

Board of Control

Harris C. Allen Otto G. Hintermann
Harry Michelsen Wayne S. Hertzka

State Association Officers

President Sylvanus B. Marston Pasadena
Vice-President Gwynn Officer Berkeley
Secretary Wayne S. Hertzka San Francisco
Treasurer Robert H. Orr, Los Angeles

Regional Director, A. I. A.

Albert J. Evers, San Francisco

Deputy Regional Director, Southern California

Gordon B. Kaufmann, Los Angeles

Executive Board—Northern Section Officers

President Sylvanus B. Marston Berkeley
Vice-Pres. Ernest E. Weihe, San Francisco
Secretary Wayne S. Hertzka, San Francisco
Treasurer Otto G. Hintermann, San Francisco

Directors

Harry J. Devine R. H. Reimers
Wm. J. Merchant Harold Weeks

Executive Board—Southern Section Officers

President Sylvanus B. Marston
Vice-President Louis N. Crawford
Secretary Winsor Soule
Treasurer Robert H. Orr

Directors

Merrill W. Baird Abe Edelman
Harold C. Chambers George D. Riddle

Advisors—Northern Section

Harris C. Allen San Francisco
J. K. Ballantine, Jr. (Secretary)
Sam. Lightner Hyman
Wm. G. Merchant
Jas. F. McGuiness
Dodge A. Riedy
Harold H. Weeks
Ernest E. Weihe
Albert R. Williams
Fred. H. Reimers (President)
C. A. Caulkins North Bay District
Peter Sala Lower San Joaquin District
J. U. Cloudsley (Secretary)
Edw. W. Kress Santa Clara Valley
Mario Corbett San Mateo
Alden Cambell Sacramento
Ernest J. Kump Upper San Joaquin
Dole F. Thomsen Palo Alto
Norman W. Sexton Marin
Geo. P. Simonds East Bay
Chester Treichel East Bay
Gwynn Officer Berkeley
F. T. Georgeson Redwood Empire
Casebolt Dakin Upper Sacramento
Ralph Taylor Lassen District

1939 GREETING

To ALL our members, best wishes for a prosperous (and therefore Happy) New Year. Nineteen thirty eight turned out to be an improvement over the past cycle of seven lean years, for most of us; and the prospects for continuing, even increased building activities, are most encouraging. Our prosperity is, of course, shared with the contractors and producers and all the allied branches of the building industry, and in California architects have awakened to the realization of this fact. More and more we are consulting and working together for the benefit of our own common interests—and in no small degree, for the welfare of the public. This is the course of wisdom.

COMMITTEES

President Gwynn Officer has appointed committee personnel for the ensuing year, as follows:

GOVERNMENTAL RELATIONS & LEGISLATIVE COMMITTEE

1. Devine, Harry—Chairman
2. Donovan John J.—Vice Chairman
3. Michelsen, Harry
4. Evers, Albert
5. Weeks, Harold
6. Hintermann, Otto
7. Meyer, Fred H.

PROFESSIONAL RELATIONS

1. Weihe, Ernest—Chairman
2. MacDonald, Earl—Vice Chairman
3. Raney, Vincent
4. Perry, Warren C.
5. Kett, Conrad F. T.
6. Ambrose, Wm. Clement
7. Baumberger, Walter
8. Goodman, Michael
9. Haymond, Scott

INDUSTRIAL RELATIONS

1. Reimers, Frederick—Chairman
2. Kent, Thomas—Vice Chairman
3. Michelsen, Harry
4. Paugh, Wilbur
5. Roller, Albert
6. Dinwiddie, John Ekin

FINANCIAL RELATIONS

1. Merchant, Wm.—Chairman
2. Masten, Charles—Vice Chairman
3. Clark Birge
4. Gutterson, Henry
5. Sawyer, Houghton
6. Mitchell, Jas. H.
7. Jorgensen, Mark T.
8. Klinkhardt, George R.
9. Mayo, Frank V.

PUBLIC RELATIONS

1. Allen, Harris—Chairman
2. Born, Ernest—Vice Chairman
3. Johnson, Ellsworth
4. Hertzka, Wayne S.
5. Collins, Henry C.
6. Warnecke, Carl
7. Morrow Irving

TECHNICAL RELATIONS

1. Meyer, Fred H.—Chairman
2. Corlett, Wm.—Vice Chairman
3. Ashley, Frederick
4. Steilberg, Walter T.
5. Williams, Albert

ARCHITECTS' BOARD OF CONTROL

1. Allen, Harris C.
2. Hintermann, Otto G.
3. Johnson, Ellsworth
4. Miller, Chester
5. Dailey, Gardner
6. Michelsen, Harry

DISTRICT SOCIETIES

1. Simonds, George—Chairman
2. Johnson, Ellsworth—Vice Chairman
3. Georgeson, F. T.
4. Sexton, Norman
5. Campbell, Alden
6. Caulkins, C. A.
7. Sala, Peter
8. Thomson, Dole F.
9. Reimers, Frederick
10. Young, John Davis
11. Bissell, Howard G.
12. Blodgett, Edward O.

ENTERTAINMENT COMMITTEE

1. Ballantine, John K.—Chairman
2. Stringham, Roland—Vice Chairman
3. Garren, Wm. I.
4. Hintermann, Otto
5. Allen, Harris C.
6. Appleton, A.
7. Johnson, Ellsworth

DRAFTSMEN'S ORGANIZATIONS

1. Raney, Vincent—Chairman
2. Evers, Albert—Vice Chairman
3. Hintermann, Otto
4. Boutlier, John F.
5. Weihe, Ernest E.
6. Flanders, Edward F.
7. Jeans, Raymond
8. Bernardi, Theodore C.
9. Goodman, Michael

TREASURER'S COMMITTEE

1. Hintermann, Otto—Chairman
2. Keyser, Lawrence
3. Pring, Thomas

COMMITTEE TO ACT WITH PACIFIC BUILDING OFFICIALS CONFERENCE

1. Meyer, Fred H. } Nominated
2. Ashley, Frederick } by N. S.
3. Steilberg, Walter }

PRACTICE ACT COMMITTEE FROM N. S. TO PRESENT SAME TO LEGISLATURE

1. Meyer, Frederick } By Resolution—
2. Michelsen, Harry } October 25, 1938
3. Devine, Harry J. }
4. Evers, Albert }

ENGINEERS NAME OFFICERS FOR 1939

"The Trend of State Highway Construction in California," was the subject of a symposium featuring the first regular meeting for 1939 of Los Angeles Section, American Society of Civil Engineers. Following are this year's officers:

President, H. Macy Jones, M.Am.Soc.C.E.

First Vice-president, Julian Hinds, M.Am.Soc.C.E.

Second Vice-president, Robert V. Labarre, M.Am.Soc.C.E.

Secretary, Ray L. Derby, Assoc. M.Am.Soc.C.E.

Treasurer, Donald H. McCreery, Assoc. M.Am.Soc.C.E.

Officers of Junior Forum:

President, William W. Moore, Jr.Am.Soc.C.E.

Vice-president, George E. Brandow, Jr.Am.Soc.C.E.

Secretary-Treasurer, Sterling S. Green, Jr.Am.Soc.C.E.

SOUTHERN CALIFORNIA CHAPTER

At the December meeting of Southern California Chapter, A. I. A., officers and directors for 1939 were elected as follows: Eugene Weston, Jr., president; Edgar Bissantz, vice-president; Ben H. Connor, secretary; Earl T. Heitschmidt, treasurer; Samuel E. Lunden was elected a director for the three-year term.

Edwin Bergtrom, treasurer of the Institute, announced that the 1939 national convention of the Institute would be held jointly with the International Association of Architects in Washington, D. C., in September.

Eugene Weston, Jr., who presided, stated the January meeting of the Chapter would be held jointly with the State Association of California Architects. The February meeting will be the "Honor Awards" meeting and will be held at the Biltmore Hotel in Los Angeles.

Donald B. Kirby, chairman of the publicity committee, reported on the activities of his committee and introduced John R. Little, who has been retained by the Chapter to act in an advisory capacity on publicity matters.

Following the business session, the meeting was turned over to the associate members of the Chapter, who gave their version of what may be expected in the way of reports on Chapter and Institute affairs in the year 1939. George Allison acted as chairman of this part of the meeting.

OPPOSE GOVERNMENT ENCROACHMENT

The competition which government is giving private architects was vigorously assailed at the first convention of New York State Architects recently held in New York City when Wesley S. Bessell of the New York Chapter said that only 10 per cent of all architectural business in the United States is open to private practitioners.

He pointed out that 75 per cent of the architectural work lies in the field of small houses put up by speculative builders, with another 10 per cent in heavy construction, such as manufacturing plants, little of which is done by architects. Government building he said amounts to another 5 per cent, which is monopolized by public bureaus.

"This leaves but 10 per cent of the entire architectural work of the country at our disposal," Bessell said, "and at the present time this 10 per cent is stalemated by the business recession, and from this we are striving to eke out an existence.

"If the Federal government is serious in its endeavor to start the wheels of private industry and private work moving, why does it not cease usurping our functions and distribute this work over many parts of the country where it will help reestablish offices and do the greatest amount of good in helping the architects to make a living?"

Mr. Bessell advocated "A Boston Tea Party" to throw over existing governmental bureaus which compete with private architects, saying "We have two alternatives—either to fight this racket or to accept. If we fight, then the logical way is to strike with laws emanating from our own group."

Richmond H. Shreve, a director of the Institute, stated that only through professional organization could the architects be protected against unjust actions of Federal, state, county and municipal bureaus. The architects, he said, should sell themselves to the public rather than try to legislate existing government bureaus out of business.

Sidney L. Strauss gave Grover A. Whalen a lashing for his handling of architectural work at the New York World's Fair. Most of the work there was handled by bureaus, he said, the private architect getting only a small part of all the work from "great dictator" Whalen.

—Exchange.

ENGINEERS AND ARCHITECTS

Members and friends of the Engineers & Architects Association of Southern California held an enjoyable holiday season meeting December 16 with a visit to the Bethlehem Steel plant on East Slauson Avenue in Vernon, thence to the utility electric steel foundry, and later to the Cook Heat Treating Corporation.

The regular dinner followed at the Royal Palms Hotel. Fire Chief Scott told about the brush fire in the Santa Monica Mountains, and C. B. Troedsson of the University of Southern California gave an illustrated lecture.

With the Architects

OFFICE AND STORES

Thomas M. Edwards, architect of San Francisco, is preparing drawings for a one story reinforced concrete and terra cotta office and store building at Fourth Avenue and San Mateo Drive, San Mateo, for the Parrott Investment Company, 155 Montgomery Street, San Francisco. Mr. Edwards has awarded all contracts on the new Half Moon Bay High School, aggregating \$137,000.

OAKLAND AMPHITHEATER

Edward T. Foulkes has made plans for a one story reinforced concrete amphitheater for the Park Department, City of Oakland, in Sequoia Park. W.P.A. labor will be employed on this quarter of a million dollar job.

SAN FRANCISCO APARTMENTS

A three story frame apartment house will be erected on the south side of Pacific Avenue, San Francisco, for V. Rasmussen from plans by H. C. Baumann, 251 Kearny Street, San Francisco. The owner will invest \$40,000 in the improvements.

SACRAMENTO APARTMENTS

Herbert Goodpastor, Mitau Building, Sacramento, is preparing drawings for a \$30,000 two story frame apartment house for an unnamed client. There will be 16 one and two room apartments.

The same architect has recently let a contract for a \$15,000 store building at 16th and H Streets, Sacramento, for Safeway Stores, Inc.

SAN FRANCISCO HOSPITAL

Martin Rist, Phelan Building, San Francisco, is preparing working drawings for a 48 room homeopathic hospital at California and Maple Streets, San Francisco. The building will cover ground area 200 x 50 ft. There will be two elevators.

AUTO SALES BUILDING

Plans have been completed and bids taken for an auto sales building in San Rafael for Emil Bianco. The architect, Norman W. Sexton of San Francisco, has planned a one story reinforced concrete structure with wood roof trusses. The estimated cost is \$12,000.

BURLINGAME RESIDENCE

Mario Corbett, 72 Third Avenue, San Mateo, has completed plans for a one story frame and stucco residence to be built on Hillside Drive in the Burlingame Hills for Henry Park, 1230 Broadway, Burlingame. The six room structure will cost \$9,000.

THIRTEEN RESIDENCES

Meyer Brothers, 735 Portola Drive, San Francisco, have announced the early construction of thirteen one story frame residences to cost \$5,000 in a tract of land bounded by Sequoia Way and Teresita Boulevard, San Francisco.

BARRACKS BUILDINGS

The Federal Government will start work this spring on a group of reinforced concrete buildings with tile roof in Honolulu, T. H., to be known as Schofield Barracks. More than \$1,000,000 will be expended on the improvements.

MODESTO MARKET BUILDING

A one story reinforced concrete market building to cost \$20,000 is being designed for a Modesto business man by G. N. Hilburn, architect, of Modesto.

ERNEST KRUMP, SR., BETTER

Ernest Kump, Sr., who has not been in good health for the past six months, is reported to be considerably improved but will shortly enjoy a trip which will take him away from active business affairs for a while. Meanwhile his Fresno office is busy with several important jobs, including two schools.

SANTA ROSA HOSPITAL

Bids have been taken for the construction of a tubercular ward at the Sonoma County Hospital, Santa Rosa. Construction will be frame and stucco with tile roof. John I. Esterly is architect of the \$140,000 structure.

PERSONALS

Le Roy Barton, A. I. A., began his new duties as Acting Supervising Architect of Public Buildings Branch, Procurement Division, January 1. Mr. Barton is also an assistant to the Secretary of the Treasury, Louis H. Simon, who has been Acting Supervising Architect, retires from official work June 1.

Paul M. Jewell, associate architect with Jones and Stanley, Medical Arts Building, Seattle, recently formed a partnership with Hugh Cook under the firm name of Cook and Jewell with office at 730 S. W. Salmon Street., Portland.

Baker, Stewart & Palmaw, Seattle architectural firm, is now located at 406 Railway Exchange Building, having moved recently from the Burke Building, Seattle.

Don Edwards of Almira, Wash., junior at the University of Washington, has been awarded first prize in the annual contest sponsored by the School of Architecture at the university.

Marble—(See Dealers)

Painting—

Two-coat work	36c per yard
Three-coat work	50c per yard
Cold Water Painting.....	10c per yard
Whitewashing	4c per yard
Turpentine, 65c per gal., in 5 gal. cans, and 55c per gal. in drums.	
Raw Linseed Oil—97c gal. in bbls.	
Boiled Linseed Oil—\$1.00 gal. in bbls.	
Medusa Portland Cement Paint, 20c per lb.	
Pioneer or Dutch Boy White Lead in Oil (in steel kegs).	
	Per Lb.
1 ton lots, 100 lbs. net weight.....	10/4c
500 lbs. and less than 1 ton lots.....	10/2c
Less than 500 lb. lots.....	11c

Pioneer or Dutch Boy Red Lead and Litharge (in steel kegs).	
	Per Lb.
1 ton lots, 100 lb. kegs, net weight.....	10/4c
500 lbs. and less than 1 ton lots.....	10/2c
Less than 500 lb. lots.....	11c

Pioneer Red Lead in Oil (in steel kegs)	
	Per Lb.
1 ton lots, 100 lb. kegs, net weight.....	11/4c
500 lbs. and less than 1 ton lots.....	11/2c
Less than 500 lb. lots.....	12c
Note—Accessibility and conditions cause some variance in costs.	

Patent Chimneys—

6-inch	\$1.25 lineal foot
8-inch	1.75 lineal foot
10-inch	2.25 lineal foot
12-inch	3.00 lineal foot

Plastering—Interior—

	Yard
1 coat, brown mortar only, wood lath.....	\$0.75
2 coats, lime mortar hard finish, wood lath85
2 coats, hard wall plaster, wood lath.....	.85
3 coats, metal lath and plaster.....	1.50
Keene cement on metal lath.....	1.60
Ceilings with 3/4 hot roll channels metal lath90

Ceilings with 3/4 hot roll channels metal lath plastered	1.65
Single partition 3/4 channel lath 1 side85
Single partition 3/4 channel lath 2 sides 2 inches thick	1.50
4-inch double partition 3/4 channel lath 2 sides	1.30
4-inch double partition 3/4 channel lath 2 sides plastered	3.00
Plastering—Exterior—	Yard
2 coats cement finish, brick or concrete wall	\$1.00
2 coats Calaveras cement, brick or concrete wall	1.35
3 coats cement finish, No. 18 gauge wire mesh	1.50
3 coats Calaveras white finish, No. 18 gauge wire mesh	1.75

Wood lath, \$7.50 to \$8.00 per 1000.	
2.5-lb. metal lath (dipped)17
2.5-lb. metal lath (galvanized)20
3.4-lb. metal lath (dipped)22
3.4-lb. metal lath (galvanized)28
3/4-inch hot roll channels, \$72 per ton.	
Finish plaster, \$18.90 ton; in paper sacks.	
Dealer's commission, \$1.00 off above quotations.	
\$13.85 (rebate 10c sack).	
Lime, f.o.b. warehouse, \$2.25 bbl.; cars, \$2.15 lime, bulk (ton 2000 lbs.), \$16.00 ton.	
Wall Board 5 ply, \$50.00 per M.	
Hydrate Lime, \$19.50 ton.	
Plasterers Wage Scale	\$1.25 per hour
Lathers Wage Scale	1.25 per hour
Ho'd Carriers Wage Scale	1.10 per hour
Composition Stucco—\$1.80 to \$2.00 sq. yard (applied).	

Plumbing—

From \$70.00 per fixture up, according to grade, quantity and runs.

Roofing—

"Standard" tar and gravel, \$6.50 per sq. for 30 sqs. or over.
 Less than 30 sqs. \$7.00 per sq.
 Tile, \$20.00 to \$35.00 per square.
 Redwood Shingles, \$7.50 per square in place.
 Copper \$16.50 to \$18.00 per sq. in place.
 Cedar Shingles, \$8.00 per sq. in place.
 Re-coat with Gravel, \$3.00 per sq.
 Asbestos Shingles, \$15 to \$25 per sq laid.

Slate, from \$25.00 to \$60.00 per sq. yard, according to color and thickness.
 Shakes—1/25" resawn

Shakes—1/25" resawn

Sheet Metal—
 Windows—Metal, \$1.75 a sq. foot.
 Fire doors (average), including hardware \$1.75 per sq. ft.

Skylights—(not glazed)
 Copper, 90c sq. ft. (flat).
 Galvanized iron, 30c sq. ft. (flat).
 Vented hip skylights 60c sq. ft.

Steel—Structural
 \$120 ton (erected), this quotation is an average for comparatively small quantities. Light truss work higher. Plain beams and column work in large quantities \$90 to \$100 per ton.

Steel Reinforcing—
 \$80.00 to \$120.00 per ton, set.

Stone—
 Granite, average, \$6.50 cu. foot in place.
 Sandstone, average Blue, \$4.00. Boise \$3.00 sq. ft. in place.
 Indiana Limestone, \$2.80 per sq. ft. in place.

Store Fronts—
 Copper sash bars for store fronts, corner center and around sides, will average 75c per lineal foot.
 Note—Consult with agents.

Tile—Floor, Wainscot, etc.— (See Dealers)
 Asphalt Tile—18c to 28c per sq. ft. installed.

Wall Tile—
 Glazed Terra Cotta Wall Units (single faced) laid in place—approximate prices:
 2 x 6 x 12

Venetian Blinds—
 40c per square foot and up. Installation extra.

THE BUILDERS' EXCHANGE OF SAN FRANCISCO STANDARD WAGE SCALE

For mechanics employed on construction work in the Bay Region. Effective September 1, 1937

CRAFT	Journeymen Mechanics	CRAFT	Journeymen Mechanics	CRAFT	Journeymen Mechanics
Asbestos Workers	\$ 8.00	Laborers, Building (8h-5d)	\$ 6.00	Steam Fitters (8h-5d)	\$11.00
Bricklayers (6h-5d)	10.50	Laborers, Common (8h-5d)	6.00	Stair Builders (8h-5d)	9.00
Bricklayers, Hodcarriers (6h-5d)	6.75	Lathers, Channel Iron (8h-5d)	9.00	Stone Cutters, Soft and Granite (8h-5d)	8.00
Cabinet Workers (Outside) (5d)	8.00	Lathers, All Others	9.00	Stone Setters, Soft and Granite	12.00
Caisson Workers (Open)	6.40	Marble Setters (8h-5d)	10.50	Stone Derricks	9.00
Carpenters (8h-5d)	10.00	Marble Setters' Helpers (8h-5d)	5.50	Tile Setters (8h-5d)	11.00
Cement Finishers (8h-5d)	9.00	Millwrights	9.00	Tile Setters' Helpers (8h-5d)	6.50
Cork Insulation Workers (8h-5d)	1.50	Model Makers (\$1.50 per hr-6h)	9.00	Tile, Cork and Rubber (8h-5d)	9.00
Electric Workers (8h-5d)	11.00	Modelers (\$2 per hr-6h)	12.00	Welders, Structural Steel Frame on Buildings	11.00
Electrical Fixture Hangers	8.00	Model Casters	7.20	Welders, All Others on Buildings	9.00
Elevator Constructors	10.40	Mosaic and Terrazzo Workers (Outside)	9.00	Dump Truck Drivers, 2 yards or less	6.00
Engineers, Portable & Hoisting	9.00	Painters (7h-5d)	8.50	Dump Truck Drivers, 3 yards	6.50
Glass Workers (8h-5d)	9.68	Painters, Varnishers and Polishers (Outside)	9.00	Dump Truck Drivers, 4 yards	7.00
Hardwood Floormen	9.00	Pile Drivers and Wharf Builders	9.00	Dump Truck Drivers, 5 yards	7.00
Housesmiths, Architectural Iron (Shop) (8h-5d)	9.00	File Drivers' Engineers	10.00	Dump Truck Drivers, 6 yards	7.50
Housesmiths, Architectural Iron (Outside) (8h-5d)	9.00	Plasterers (6h-5d)	10.00	Truck Drivers of Concrete Mixer Trucks:	
Housesmiths, Reinforced Concrete or Rodmen (8h-5d)	10.00	Plasterers, Hodcarriers (6h-5d)	7.50	2 yards or less	6.50
Iron Workers (Bridge and Structural) Including Engineers (8h-5d)	12.00	Plumbers (8h-5d)	11.00	3 yards	7.00
		Roofers, Composition (8h-5d)	9.00	4 yards	7.50
		Roofers, All Others (8h-5d)	8.00	5 yards	7.50
		Sheet Metal Workers (8h-5d)	10.00	6 yards	8.00
		Sprinkler Fitters	10.00		

GENERAL WORKING CONDITIONS

- Eight hours shall constitute a day's work for all crafts except as otherwise noted.
- Plasterers' Hodcarriers, Bricklayers' Hodcarriers, Roofers' Laborers, and Engineers, Portable and Hoisting, shall start 15 minutes before other workmen, both at morning and at noon.
- Five days, consisting of not more than eight hours a day, on Monday to Friday inclusive, shall constitute a week's work.
- Transportation costs in excess of twenty-five cents each way shall be paid by the contractor.
- Overtime shall be paid as follows: For the first four hours after the first eight hours, time and one-half. All time thereafter shall be paid

- double time, Saturdays (except Laborers), Sundays and holidays, from 12 midnight of the preceding day, shall be paid double time.
- On Saturday, Laborers shall be paid straight time for an eight-hour day.
- Where two shifts are worked in any twenty-four hours, shift time shall be straight time. Where three shifts are worked, eight hours' pay shall be paid for seven hours on the second and third shifts, allowing one-half hour for lunch.
- All work, except as noted in paragraph 9, shall be performed between the hours of 8 a.m. and 5 p.m.
- In emergencies, or where premises cannot be vacated until the close of business, men then

- reporting for work shall work at straight time. Any work performed on such jobs after mid night shall be paid time and one-half up to four hours of overtime and double time thereafter, provided, that if a new crew is employed on Saturdays, Sundays or holidays which has not worked during the five preceding days, such crew shall be paid time and one-half.
- Recognized holidays to be: New Year's Day, Decoration Day, Fourth of July, Labor Day, Admission Day, Thanksgiving Day, Christmas Day.
- Men ordered to report for work, for whom no employment is provided, shall be entitled to two hours' pay.

MODERNIZED PRODUCTS

Brief Notes on New Materials and Equipment in the Building Industry.

151. MAPLE FLOORS

The Maple Flooring Manufacturers Association announces a new set of specifications for heavy duty and gymnasium finishes using maple, beech and birch. This should prove of value to specification writers. Send for your copy by clipping the coupon.

152. LAMINEX DOORS

A new door catalogue issued by the Wheeler-Osgood Corporation is available now and illustrates Woco Laminex. Special and standard doors are shown in a variety of types. Color plates are used to demonstrate the finishes that may be applied to these various doors. Altogether a most illuminating catalogue. Send for a copy.

153. CLAY PIPE

A new broadside has come to us; that issued by the Robbinson Clay Product Company, illustrating their new vitrified clay Skip-Pipe. This is an under drain and insures capacity drainage equal to a full round pipe. The coupon will bring you a copy.

154. COPPER USES

The November Bulletin of the Copper and Brass Research Association is particularly interesting and contains some excellent ideas well illustrated. As is usual the cover is very appropriate. One portion of the bulletin is devoted to the use of copper and alloys in automobiles.

155. HEATING UNITS

The American Radiator Company has issued an attractive booklet called "The Arco-Tect," using their trade name as the fore part of the title. The pamphlet deals with heating units manufactured by this company and has several features of interest. Send for your copy.

156. UNIT HEATERS

The John J. Nesbit Company and the Warren Webster Company have issued a large catalogue featuring the Nesbit-Webster giant unit heater. It is a complete booklet and contains all the tables of heating, etc., together with illustrations.

157. ACETYLENE BULLETIN

"Oxy-Acetylene Tips," monthly bulletin for December put out by the Linde Air Products Company, is an extremely interesting number. The latest advances in welding and kindred procedures are commented upon and illustrated. The coupon will bring you a copy.

158. GAS STEAM RADIATOR

The Pittsburgh Automatic and Gas Steam Radiator is illustrated in a brochure by the Automatic Gas Steam Radiator Company. This is a unit that produces steam heat without boiler, water pipes, coal, ashes or janitor, to quote from the title of the brochure. It seems to be so complete that we are wondering if we read the title aright; perhaps it produces steam heat without even a radiator.

159. NEW LAMP

"Curtistrip" a new fluorescent lamp is illustrated in a broadside sent out by the Curtis Lighting Company. The details are explained and there are several diagrammatic sketches. Send for your copy by using the coupon.

160. WINDOW CONDITIONING

Another of the excellent booklets issued by Libbey-Owens-Ford Glass Company has arrived. It details window conditioning—"the first step to winter comfort," and is well gotten up. A copy is yours by sending in the coupon.

161. CORNICES & COPINGS

Dusing and Hunt, a new firm as far as their literature is concerned, to appear in this column, has just issued a booklet covering the details of their copings, cornices, sills, etc.; sketches illustrate these products.

162. FLOOR PATCHER

From the Midland Paint & Varnish Company comes an attractive brochure telling the story of their "Clev-O-Cement" (for making permanent patches on broken cement floors). This product should be most desirable for concrete contractors and by all rights should prove of interest to building owners. Clip the coupon for your copy.

163. PLUMBING FIXTURES

Crane Company have sent out a very fine booklet embracing in its contents the results of research in materials used in modern plumbing fixtures and appurtenances. They have called this booklet "Crane Research Laboratories." The coupon will bring you a copy of an extremely interesting volume.

164. GLASS BLOCKS

The Owens-Illinois Glass Company have some fine views and data on their Insulux glass blocks, which should be of interest to the building professions. Some of these pictures illustrate the treatment used in a small modern bar in an apartment.

FREE FOR THE ASKING

Check items on coupon, paste on letter head or postal card, and mail to Architect and Engineer.

|
| Architect and Engineer
| 68 Post Street
| San Francisco, Calif.
|
| Please send me literature on the following
| items as checked below. This request
| places me under no obligation.
|
|
| 151 158
| 152 159
| 153 160
| 154 161
| 155 162
| 156 163
| 157 164
|
| My Name _____
|
| Name of Company _____
|
| Street _____
|
| City _____ State _____

Competition for Semi-rural House

The purpose of this competition is to encourage and stimulate architects in every region of the United States to the fullest consideration of the problems involved in the design of a house fitted to semi-rural living. The productive home as regarded by the sponsors is a home located on productive land in the country, but within transportation distance of the places where the members of the family have businesses or are employed. The goal of each family is to add to its economic security through production in the home, shop, studio and garden.

The competition is sponsored by three organizations, all of which are devoted to the advancement of the plan of decentralization of industry, land conservation, domestic production, and widespread small property ownership.

(1) "Free America" is a monthly magazine which acts as spokesman for individual educators and economists interested in this movement.

(2) The School of Living is a research and educational institution which publishes studies in homestead economics and gives practical assistance to city dwellers who desire to move into the country and establish productive homes.

(3) The Independence Foundation is a non-profit institution which lends private funds to establish homestead communities and to finance the houses of individual homesteaders who desire to acquire land and build productive homes on a cooperative self-liquidating basis.

The competition will embrace five competitions for regional designs: (1) The Northeast; (2) The South; (3) The Middle West; (4) The Southwest; and (5) The Northwest.

The competition will consist of two stages. The first stage is open to every architect in the United States, and any architect, regardless of his place of residence or work may submit designs for any or all regions. There is no residence requirement of any kind: each regional competition is held on the basis of designs alone. The second stage will be open to 55 architects, submitting designs intended for each region. These architects will be selected by a jury from those competing in the first stage. There will be five prizes of \$1,000 each and fifty additional awards of \$100 each to the 55 competitors in the second stage.

The jury of the first stage will consist of three members selected by the sponsors. The jury of the second stage will consist of the original three jurors, augmented by two others selected by the ballots of the 55 final competitors.

The five winners of first prizes will be required to submit drawings and specifications necessary for the con-

duct of the work. There are no mandatory requirements as regards materials, styles, or methods of construction; but it is the desire of the sponsors to award prizes for the best designs indigenous to each region. If, in the opinion of the judges, any or all of the plans submitted for any single region are lacking sufficient merit to justify prizes, the prize money allocated to the designs for that region will be suitably distributed among the invited final competitors submitting designs indigenous to other regions.

Organization of the preliminary terms of the competition has been in the hands of a committee representing the sponsors and consisting of George F. Havell, Chauncey D. Stillman, and George Weller, New York representative of the Independence Foundation and the School of Living.

This committee has retained Walter Sanders, A.I.A., practicing architect of New York City, as professional adviser, and Elliott Taylor, writer on housing subjects, as manager of the competition.

Copies of the program may be obtained by writing to the Professional Adviser, The Productive Home Architectural Competition, 381 Fourth Avenue, New York City. The program will be mailed to reach all competitors on or before February 1.

SMALL HOUSE COMPETITION

A competition for small house designs open to architects and architectural draftsmen in Southern California is announced by Los Angeles Brick Exchange, Inc. The competition will be conducted under the auspices of Southern California Chapter, American Institute of Architects, with H. Roy Kelley, A. I. A., as professional adviser. The jury of award will consist of three members of the Chapter.

Cash prizes aggregating \$1,300 are offered, \$650 in each of two groups designated as "A" and "B," and there will be five prizes in each group as follows: First prize, \$350; second, \$150; third, \$75; fourth, \$50; fifth, \$25. The competition will close March 15, 1939.

Drawings are to be delivered not later than 5:00 P.M., March 15, to Miss Elizabeth Clifford, Building Material Exhibit, Architects Building, 832 West Fifth Street, Los Angeles.

SKETCHING COMPETITION

More than 60 drawings, the work of architects and architectural draftsmen, were exhibited in the Study Gallery of the Seattle Art Museum in November. The exhibit was sponsored by the Washington State Chapter, A.I.A. First prize went to Les Oquist, second to Paul H. Kirk, and third to John T. Jacobsen.



This is

THE HOUSE THAT COFFEE BUILT

NEW BUSINESS HOME OF GEO. W. CASWELL CO., SAN FRANCISCO

This is THE GAS ROASTER THAT SAFEGUARDS FAMOUS
FLAVOR IN THE HOUSE THAT COFFEE BUILT

is is THE GAS BOILER THAT GENERATES THE STEAM
THAT HEATS THE HOUSE THAT COFFEE BUILT

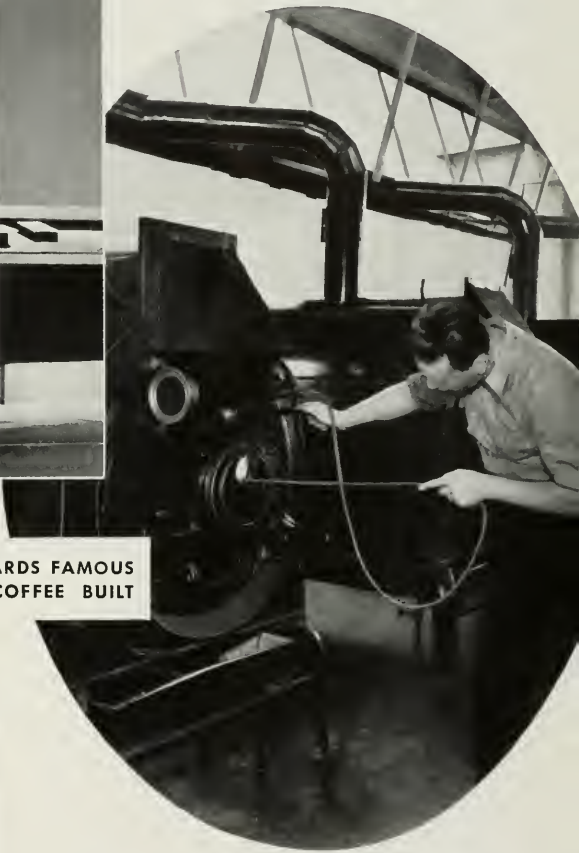
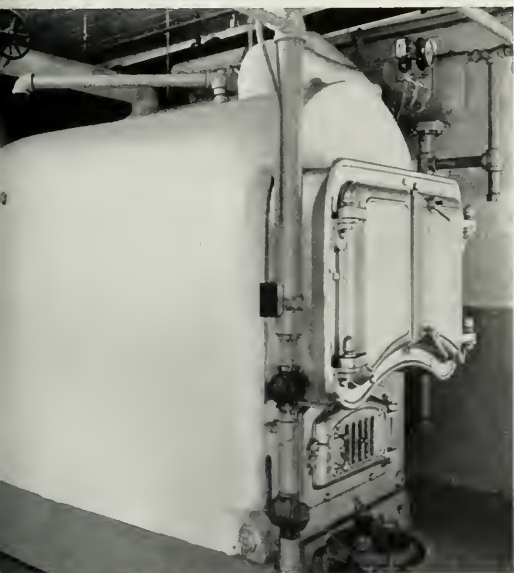

In planning and equipping this 4-story, reinforced concrete building, architects *Masten, Hurd & Roeth* and structural engineer *W. L. Huber* brilliantly interpreted modern commercial design . . . combining practical utility with classic simplicity. ☆ Gas equipment throughout safeguards the immaculate cleanliness that is Caswell's pride. The gas-fired steam boiler is automatically controlled. Gas-fired coffee roasters assure the exact temperatures required for Caswell's famous "National Crest" quality and flavor. ☆ For every heat requirement of Industry . . . as well as homes and public buildings . . . there is a modern, efficient application of Gas fuel. ☆ Architects, builders, owners are invited to consult the Gas Company's industrial engineers . . . a free technical service.

GAS

THE MODERN FUEL

ICK * CLEAN * CONTROLLABLE * DEPENDABLE * ECONOMICAL

THE S. T. JOHNSON COMPANY

pioneer manufacturer of high quality oil burners

announces a NEW 'BANKHEAT' MODEL BURNER

of the Pressure Atomizer Type

improved in design and efficiency...at an amazingly low price

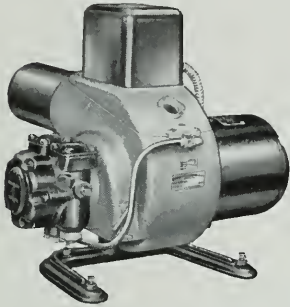

- Built to Johnson standards, this new model has been designed for installation in almost all available boiler bases.
- Underwriters' listed, with complete set of controls, room thermostat, master control and boiler or furnace limit control.
- Firing assembly and fan easily accessible. High tension transformer connection to ignition cables completely enclosed within burner.

'Data sheets on request.'

- **BANKHEAT Pressure Type Burners** now available in capacities from .8 to 7½ gallons per hour.

{Choice territories and Johnson franchises available}



S. T. JOHNSON CO.

940 ARLINGTON, OAKLAND, CALIFORNIA
401 N. BROAD STREET, PHILADELPHIA, PA.

Distributors and dealers in principal cities throughout the world

THERE'S A JOHNSON OIL BURNER FOR EVERY PURPOSE



For GAS HEAT choose the DELCO CONDITIONAIR

Built and Backed by General Motors

● This extremely efficient unit automatically warms, purifies, humidifies and circulates the air—supplies complete winter air conditioning to which summer cooling can easily be added. A quality product of unusual efficiency with the plus value of the "General Motors" name. Also models for oil heat. Get complete specifications from —

ALADDIN HEATING CORPORATION

Delco-Frigidaire Dealer

2222 SAN PABLO AVENUE • OAKLAND

FIRST 20 CITIES IN U. S. BUILDING

Five California cities are listed among the twenty cities of the U. S. in volume of building reported for 1938. Los Angeles is in second place and San Francisco third.

The total volume of building permits for 215 cities for the first eleven months of 1938 exceeded the billion dollar mark for the second time since 1931, according to reports compiled by Dun & Bradstreet, Inc. The amount was \$1,057,950,033 as compared with \$1,012,171,992 for the corresponding period last year, a gain of 4.5 per cent.

Following are the twenty cities reporting the largest amount of building for 11 months of 1938 with comparative figures for last year:

	Eleven Months		Change P. Ct.
	1938	1937	
New York, N. Y.	\$343,039,249	\$231,039,750	+ 48.5
Los Angeles, Calif.	63,085,846	59,663,807	+ 5.9
Detroit, Mich.	47,541,757	50,605,800	- 6.1
Washington, D. C.	26,456,170	30,228,040	-12.5
Houston, Texas	23,528,855	17,120,255	+ 37.4
San Francisco, Calif.	21,112,003	19,314,609	+ 9.3
Chicago, Ill.	18,847,774	27,920,268	-32.5
Philadelphia, Pa.	16,379,890	30,032,920	-45.4
Baltimore, Md.	16,219,030	15,670,390	+ 3.5
Cincinnati, Ohio	12,877,345	17,158,155	-25.0
Miami, Fla.	11,060,855	13,238,526	-16.5
Boston, Mass.	10,987,230	19,122,184	-42.5
Long Beach, Calif.	10,672,670	7,424,405	+43.7
Indianapolis, Ind.	9,680,882	7,684,455	+26.0
San Diego, Calif.	9,518,439	7,847,669	+21.3
Yonkers, N. Y.	9,370,934	4,783,172	+95.9
Pittsburgh, Pa.	9,320,886	7,817,359	+19.2
Jacksonville, Fla.	8,517,981	5,039,225	+69.0
Oakland, Calif.	8,239,449	7,733,396	+ 6.5
St. Louis, Mo.	8,090,211	8,172,965	- 1.0

PEPYS USED A SLIDE RULE

By studying Pepys' diary, Jerome Fee, engineer of San Francisco's Water Department, finds evidence that Pepys' "ruler" was a plot of logarithms which had been discovered by Napier in 1614. Pepys' ruler corresponded to the main logarithmic scale of a modern slide rule, Mr. Fee declares in the current issue of "Civil Engineering."

By using this rule, with a pair of compasses to measure off distances, it was possible to multiply and divide easily. The development of the sliding rules of modern form had not yet come into being, but quickly did so. It is possible that Pepys himself was instrumental in this achievement for he states that he had a slide rule made to order that was "certainly the best and most commodious for carrying in one's pocket, and most useful that ever was made, and myself have the honor of being, as it were, the inventor of this form of it." To Pepys also must go credit for first using the term "slide rule."

Pepys' comments on slide rules end in 1664 when he acquired one of silver and they were no longer new to him. However, 30 years later Pepys suffered losses by highway robbers and in his listing of his vanished possessions cited "a silver ruler."—Bulletin, Illinois Society of Architects.

NEW CELOTEX APPOINTMENT

Charles L. Badley, graduate of University of California 1931, formerly Construction Superintendent with F. O. Stolte Co., has been appointed by the Celotex Corporation as Architects' Representative for Northern California.

Mr. Badley will work out of the Celotex San Francisco office and will devote all of his attention to serving the architects in Northern California, having available at all times full information on the various products of the Celotex Corporation and their correct specification and application.

NEED MORE ART IN BUILDINGS

The public demand for works of art in buildings is not being adequately met, according to a report to the American Institute of Architects by Ely Jacques Kahn of New York, chairman of the Institute's Committee on Allied Arts. Rigid building budgets and lack of organization among artists are the principal difficulties, says Mr. Kahn, who suggests a revival of the Renaissance Guild.

The New York World's Fair and the Golden Gate Exposition, as well as Federal construction activity, have disclosed an increasing national interest in painting and sculpture, Mr. Kahn finds.

"At the Fairs, innumerable artists have been given opportunities, and this could only happen because public receptivity had been developed to the point where this support seemed normal," he points out. "Beyond this, however, is still a far more serious problem. From all over the country comes information that, while there is definite demand for works of art, it is very difficult to adjust building budgets to cover the necessary outlay.

"The root of the situation lies, obviously, in the fact that if the artist must rely on scattered commissions—the luck of knowing someone who has the power to award contracts—he must necessarily compute the value of the work to cover periods where there is nothing to do.

"It is clear that one cannot herd artists in a group and value their products as one might merchandise. During long periods of European history, Guilds of Artists were effective in stabilizing dignity, quality, and recompense. What one asks now is whether or not, in a very different world, there is still some way of assuring the artist a more serious continuance of effort. So much time is wasted on futile competition sales efforts that are distasteful and strange to the artist, that one wonders if it is too utopian to dream of groups to which an individual or a committee could turn and be assured of distinguished work at costs that can be met.

"One is aware of all of the personal problems, sensitivities, and reactions against regimentation that associations suggest, but, against that, one knows that where an architect in a small community, for example, would earnestly want some work of art for the climax of his

Coming... The New Door Catalog

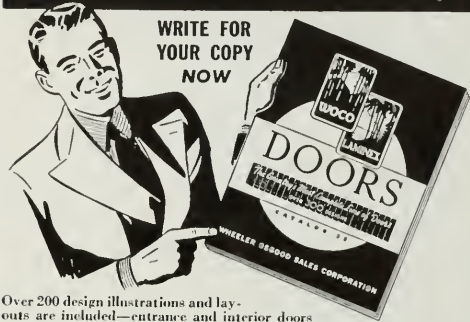

Over 200 design illustrations and lay-outs are included—entrance and interior doors for residences—overhead type and standard doors for garages—modern and conventional doors for all types of commercial buildings. It is issued by the manufacturers of the Country's Most Complete Line of Doors and contains important information, which will save money and time for you.

Write for your free copy now! It will be mailed in the order in which the requests are received. No obligation.

Note to Architects: This catalog is included in the 1939 issue of Sweet's Architectural Catalog.

WHEELER OSGOOD SALES CORPORATION

Factory: Tacoma, Washington
General Sales Offices: 122 South Michigan Avenue, Chicago, Illinois
New York • San Francisco • Los Angeles • Dallas • Wichita • Tacoma
Address Dept. C

The Country's Most Complete Line of Doors

**Pressure
Treated Lumber?**

Specify

BAXCO C ZC

**"Chromated Zinc
Chloride"**

**Protects against decay
and termite attack**

•
*Available for prompt shipment
throughout California*

•
J. H. BAXTER & CO.

401 W. 5th Street
LOS ANGELES
Phone MChigan 6294

333 Montgomery Street
SAN FRANCISCO
Phone DOuglas 3883

"The Nation's Schoolhouse Window"

DALMO Simplex Fixtures

Efficient Plumbing

KRAMER Flush Valves

Supreme Light Control

ALUMILITE Venetian Blinds



963 Harrison St.

YUkon 0123

San Francisco

"Goods of the Woods"

Dependable Building Materials

Lumber and Millwork
for
All Types of Construction

★

**Wolmanized or Creosoted
Lumber and Timbers**
is your protection against
Termites and Decay

★

E. K. WOOD LUMBER CO.

San Francisco

Los Angeles

Oakland

building, he is handicapped either by the fact that there are no individuals in his community able to carry out what he wants or he feels diffident about offering to the artist the sum that he has available.

"There must be some answer to this problem, for the architect wants the result and the artist wants the work. Here is a task for community groups and artist groups to face. In the sort of guild that might be envisaged, the younger artists could be trained on actual jobs, much as the masters of the Renaissance obtained their education.

"We have schools enough, to be sure, but not active, producing studios where talents of every nature are brought together to profit by the skill of one sparkling against the wisdom and experience of another. The Far East has shown us the way; so have various European groups whose records are available to those who would want to investigate further."

BOOK REVIEWS

AN INTRODUCTION TO FRENCH CHURCH ARCHITECTURE: By Arthur Gardner; The Macmillan Co., New York. Price: \$5.00.

This may be well listed among the finer books dealing with church architecture. An easy style of writing comprehensively on a difficult subject makes pleasant reading. There are some very fine illustrations of the choice examples of French churches.

Mr. Gardner avoids the heavy technicalities and is apparently a firm believer in brevity. Rather this book might be characterized as a means of introducing to all readers much of the church architecture of France about which specific knowledge is lacking.

COOK AT HOME IN CHINESE: By Henry Low; The Macmillan Co., New York. Price: \$2.50.

An odd little book; one which may provide considerable interest in the household where new dishes and new ways of preparing interesting foods are welcome. The author is the leading chef at one of New York's famous Chinese restaurants. He gives many of the simple and some of the more complicated dishes through which he has gained his fame. Some of these have rather astonishing ingredients but notwithstanding this they have a most fascinating sound and no doubt equally fascinating aromas and tastes. An escape from the conventional and mundane every-day foods is offered in this well written book.

STEEL CONSTRUCTION: By Bert Sandberg; American Technical Society, Chicago. Price: \$2.00.

Another of the extremely worth while publications of this Society. It covers its field with complete thoroughness; deserves a place on the shelf of the architect who wishes to keep abreast of the progress in modern construction.



WHERE 35 MILLION COMMUTERS WILL WALK—

Just completed, the new San Francisco-Oakland Bridge Train Terminal will serve an estimated 35 million commuters per year. Construction of the concrete passenger ramps was done by Kalman Floor Company, Los Angeles.

In any project built to endure, sound con-

struction should receive first consideration. Kalman Floor Company specified and used reliable Golden Gate Portland Cement exclusively.

No matter what the structure, large or small, you invest in certainty when you specify time-tested Golden Gate Cement.

GOLDEN GATE CEMENT was used **EXCLUSIVELY**

Ask Your Building Materials Dealer

San Francisco
Los Angeles

Produced by
PACIFIC PORTLAND CEMENT COMPANY
COASTWIDE SERVICE

Portland
Seattle



NEW OIL HEAT

A compact Floor Furnace Unit available in two sizes, affording ample, healthful warm air heating for residence, commercial and special installation. Available in several types of control and backed by the manufacturers of complete oil burning equipment including water heaters, furnaces, burner units, etc. . . over forty thousand installations during a period of ten years.

Write for information.

H. C. LITTLE BURNER CO.

San Rafael, California

Pacific Coast sales and service handled by 300 dependable dealers.

FACTORY BRANCHES: - LOS ANGELES - PORTLAND - SEATTLE

A good investment—

is a well designed, well built,
structure, properly located.

Lindgren & Swinerton, Inc.

have been building substantial
buildings for over a quarter of
a century, are still building them
and will continue building them
for another quarter of a century.

Lindgren & Swinerton, Inc.

Standard Oil Building
San Francisco

605 W. Tenth Street
Los Angeles

Seventh: The small house is now being successfully merchandised along lines of recognized sales methods by people or organizations equipped to do this. This is a natural function of a material dealer. He is doing it better today than ever before.

Therefore, it certainly looks as though the architects are going to have to make some concessions in order to "play on the team" if they wish to get their rightful position in this field. Since we are not now in a position to demand anything, we will have to agree to work with these interests and try to regulate them for mutual benefit. Oddly enough, they recognize that the architect's influence and ability increase the value of their product and program and that the architect is necessary to their increased success. This is demonstrated by the fact that many manufacturers, building material yards, etc. maintain their own "Architectural Departments," or employ architectural draftsmen. They especially like a draftsman with a license, paying him a pittance more for his service, while he assumes the responsibility of the design. Some of the individuals so employed are architects by decree of law. By and large they are not representative of the profession. These other people need us but have been unable to use us as a profession because we demand a fee that the public is wholly unwilling to pay.

Why don't we sit down and take stock of the whole idea, definitely find our place in the picture, and then make some correlative advances to these commercial producers and thus get our rightful share of this market? We shall have to do this because they, particularly the lumber industry, now control this field of stock plan activity and have indicated to us that they not only intend to retain it but further promote it, although they have indicated on several recent occasions a willingness and desire to have our cooperation along lines that will meet public acceptance.

The first move is to meet some of these manufacturers and discuss frankly all phases and elements of the problem, clearly understanding where each one's interest lies and then definitely recognize the rightful position of each in the picture. Once this is done the plan of procedure is a relatively simple one.

Isolated cases of cooperation between an individual architect with the other elements of the building industry in the small house field are proving fruitful to the architect. These cases are rare, so rare that mere mention of them suffices. Billings, Montana is one of them.

If this field offers us any opportunity, we should make an energetic effort to get into it. Otherwise let's forget the whole mess.—Carl E. Heimbrodt, A.I.A., Chicago, in Monthly Bulletin of Illinois Society of Architects.

ANSWERS TO MEMORY QUIZ

ON PAGE 8

First question, correct answer is name numbered (2); second, (3); third, (2); fourth, (3); fifth, (1); sixth, (3); seventh, (1).

CALL US

FOR COMPLETE
SELECTION
FROM LARGEST
GROWING STOCK
OF SPECIMEN
DECORATIVE PLANTS
AND TREES



Add Beauty

THROUGH
CAREFUL PLANTING
WHETHER FOR
RESIDENCE
COMMERCIAL
OR PUBLIC
BUILDING



Roy F. Wilcox & Co.

Wholesale Growers

MONTEBELLO (LOS ANGELES COUNTY) CALIFORNIA

Montebello 100

Angelus 4221

SAN FRANCISCO OFFICE
65 RICE STREET
RAndolph 7857

BROADCASTING TO BRICKLAYERS

A unique method of directing a large construction project covering a vast amount of land area has been demonstrated at Meadowbrook Village in Plainfield New Jersey, where the first section of a \$2,000,000 garden apartment development is being constructed by Frank H. Taylor & Son, Inc., East Orange, under the supervision of the Federal Housing Administration. This first section comprises 31 two-story apartment buildings.

A standard radio microphone has been set up in the central field office building occupied by the builders' offices, as well as the offices of the FHA. The "mike" is connected with a series of loud speakers, having highly stepped up amplification, which are placed at strategic points throughout the job. Thus an order can be given to any point or to a group of workmen in a fraction of the time that it would take for someone to cover the distance from the central office, which in some cases is approximately a quarter of a mile away. This office is therefore in direct communication with supervisors, inspectors, architects, engineers, contractors and working crews scattered all over the job.

In addition to this, field telephones connecting with the central office building are being installed. These telephones will not only connect with the central office but also with the outside so that an FHA inspector, for example, can talk with his Washington office without

Equipped with Corrosiron Fan



Life Science Building, University of California, Berkeley
Federal, State and Municipal Architects Specify

—CORROSIRON—
fans, ducts, drain pipes and fittings because
they are acid-resisting

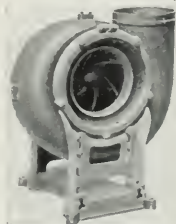

Corrosiron Fan

Architects and Mechanical
Engineers
write for suggested
specification form to

Pacific Foundry Co., Ltd.

New York Los Angeles
3100 Nineteenth Street, San Francisco, Calif.

POMONA TILES

FOR
Bathrooms and Kitchens
in over 60 colors

Warehouses and Display Rooms

135 Tenth St. San Francisco
629-33 North La Brea Ave. Los Angeles
6106 Roosevelt Way Seattle

POMONA TILE MFG. CO.
PLANT — POMONA, CALIF.



Write for "The Charm of a Well Lighted Home" — to help you plan attractive healthful lighting.

ARCHITECTS and their clients are quick to appreciate the decorative effectiveness of the new Lightoliers — especially in view of their sound construction and reasonable cost. Available in all periods, at dealers nationally or at our show-rooms.

INGANDESCENT SUPPLY CO.

SAN FRANCISCO : OAKLAND FRESNO : LOS ANGELES



A comfortable, enjoyable place to stay for over night or vacation.

EL ENCANTO HOTEL & VILLAS

Just above Santa Barbara Mission

Frank J. McCoy, Managing Director

Fred F. Pimentel, Manager

Advance Showing FOLDING WOOD SCREENS

Light weight, woven wood patterns

Manufactured by

PAINÉ LUMBER CO., LTD.
Oshkosh, Wis.

January 3rd to 27th, 1939



THE BUILDING MATERIAL EXHIBIT

Architects Bldg. • Fifth & Figueroa • Los Angeles • MU-6306

leaving the particular point which he is supervising. Important decisions that would require many valuable minutes to make and might cost hundreds of dollars through delay are therefore being made in a matter of seconds and the installation has greatly stepped up the efficiency of the entire project according to the Taylor officer who worked out this novel arrangement.—Buildings and Building Management.

TAX TRUTHS

Disturbing trends in national fiscal policy are reflected in a compendium—"Facts—About Taxes and Public Spending"—just issued by the Chamber of Commerce of the United States.

Among the facts listed, are the following:

The cost of government—federal, state and local—mounted from \$8,918,000,000 in 1923 to \$16,900,000,000 in 1937, or from \$79.96 per capita to \$130.75.

In the last fiscal year the federal government spent more than \$21,000,000 a day.

The per capita cost of federal government increased from \$27.95 in 1923 to \$62.91 in 1937.

Governments of all types collected in taxes \$7,234,000,000 in 1923. In 1937 they collected \$12,300,000,000.

If every dollar of income of persons receiving more than \$5,000 a year were to be taken in taxes, the sum would pay the cost of our numerous governments for only about six months.

It would take about 42 cents of every dollar spent in retail purchases in the United States last year to pay the cost of all governments.

Many business concerns pay more to government in taxes than they pay to stockholders in dividends. Some pay more to the tax collector than they pay to employees.

During the ten year period 1926-1935 all active corporations paid in taxes three-fifths of their total net income before taxes.

In 1937 taxes absorbed 17.6% of the national income. If taxes had been levied to cover all government expenditures, they would have taken more than 24%.

Government in recent years has spent much more than it has collected. In the eight years 1931-1938 the federal government alone spent \$23,777,000,000 more than it received.

The national indebtedness for all classes of government increased from \$5,721,000,000 in 1913 to \$55,579,000,000 in 1937, a per capita increase from \$59.28 to \$429.99.

It is estimated that more than three-fourths of the direct obligations of the Federal Government are held by banks, reserve banks, insurance companies and non-finance corporations.

British per capita taxes were \$100.81 in 1937, compared with American taxes of \$95.16 per capita.

The important difference is that government, in Great Britain, is practically paying its way, while government, in the United States is going deeper into debt.

LAMELLA ROOF TEST

(Continued from Page 4)

A series of eight separate tests was made. The first group of tests consisted of the application of lateral loads by means of hydraulic jacks to one sill only, to both sills simultaneously, and to one end of the structure. The next two tests consisted of the application of concentrated and uniform unbalanced vertical loading by means of structural steel shapes. The final series consisted of the application of lateral loads after sections of the roof sheathing had been removed, and finally after the sheathing on the end diaphragms had been completely removed. The lateral loads in the last tests were carried considerably beyond the design limits.

These tests were particularly significant to Western architects and engineers, due to the wide use of the lamella roof on all types of commercial and public buildings in this region. Evidence of the importance attached to the findings can be seen in the fact that more than two hundred and fifty architects, engineers, public officials and other members of the construction industry were present during the three days of experimental work.

The forty-page printed report of the tests is published over the signature of Frederick J. Converse of California Institute of Technology, and a limited number of copies are available for distribution.

In his report Mr. Converse states that the lateral load tests indicate that the values calculated according to the von Karman analysis are in all cases on the safe side and it is therefore evident that the method of analysis used in calculating lateral deflections is well on the side of safety and may be used with confidence under all conditions covered by the tests.

DORMITORY BUILDING

Working drawings are practically completed in the office of Anold S. Constable, 580 Market Street, San Francisco, for a two story frame and stucco dormitory building at San Rafael for Dominican College. It will accommodate 32 persons and will cost \$110,000.



PRODUCTS

VAN ARSDALE-HARRIS Co.
ENGINEERS & CONTRACTORS

ACOUSTICAL TREATMENT - INSULATION
SOUND CONTROL

FIFTH & BRANNAN STS. SAN FRANCISCO, CALIF.
TELEPHONE GARfield 3600

DIVISION

VAN ARSDALE-HARRIS LUMBER CO., INC.

INCLUDE TREES IN YOUR PLANS

DAVEY, ORIGINATOR OF TREE SURGERY, OFFERS FREE
INSPECTION AND ESTIMATE.



SAN FRANCISCO Fresno LOS ANGELES
Russ Bldg. Mattei Bldg. Story Bldg.
Sutter 3377 TUCKER 1929
Local phones in: Pasadena, Palo Alto,
Oakland, San Rafael, San Mateo

SKILL - KNOWLEDGE - RESPONSIBILITY

STRUCTURAL STEEL

For Class A Buildings,
Bridges, etc.

JUDSON PACIFIC CO.

609 MISSION STREET
SAN FRANCISCO

Plants: San Francisco - Oakland

USE BASALITE

Light-weight, pre-fabricated Con-
crete building products for floors,
walls, and roofs in your next
building.

BASALT ROCK COMPANY, INC.

Napa, California

NOISE Control

Office Quieting
Sound-proof Partitions
Acoustical Correction

WESTERN ASBESTOS CO.

Building Materials

Mechanical Specialties

SACRAMENTO OAKLAND
SAN FRANCISCO

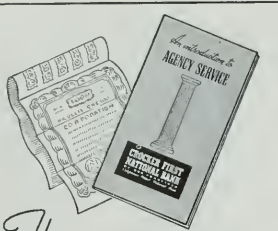

The practical way

TO HANDLE SECURITIES

With an Agency Account you retain complete authority over your holdings, but we relieve you of all time-consuming and irksome details. A simple letter of instructions is the only authorization needed to open an account. On request we shall be glad to send you our interesting booklet, *An Introduction to Agency Service*.

Ask for Booklet M-2

**CROCKER FIRST
NATIONAL BANK**
OF SAN FRANCISCO
California's Oldest National Bank



*No longer a problem
for the Architect*

**TRANSIT
MIX CONCRETE**
AND MORTAR

makes delivery of material to the job swift and inexpensive . . . minimizing the architect's supervision costs and assuring his client a dependable mix.

Speed . . . Reliability . . . Economy

Let us co-operate with you

**Golden Gate-Atlas
Materials Co.**

16th and Harrison Streets
San Francisco
UNderhill 3650

GLASS INSTITUTE AWARDS

California architects were much in evidence in the jury report of the Second Pittsburgh Glass Institute Competition recently made public. Over 500 photographs were entered for judgment. All were judged from the view point of practical and ornamental application of glass in architectural design.

The competition jury was composed of Gardner A. Dailey, architect, San Francisco; Albert Kahn, architect, Detroit; William Lescaze, architect, New York; Raymond Loewy, industrial designer; Paul R. McAllister, interior decorator, New York; and William A. Kimbel, interior decorator, New York. Howard A. Myers, editor of the Architectural Forum, was competition adviser.

The awards were announced as follows:

Grand Prize of \$1,000, engraved glass medallion, and \$100 first prize in the classification, "Houses Costing Over \$12,000"; Edward D. Stone and Carl Koch, associated architects, New York, for residence in Cambridge, Mass.

Mentions: Kenneth Day, architect, Philadelphia, for own residence in Mi- quon, Pa.; Richard J. Neutra, architect, P. Pfisterer, collaborator, Los Angeles, for residence of Mr. and Mrs. Edward Kaufman, Westwood, California.

Houses Costing Under \$12,000

Prize: Harwell Hamilton Harris and Carl Anderson, associate architect, Los Angeles, for residence of George C. Bauer, Glendale, California.

Mentions: Clarence W. Mayhew, architect, Oakland, for residence of Harold V. Manor, Orinda; George Patton Simonds, architect, Hayward, for residence of Mr. and Mrs. William Roger Stoll, Hayward, California.

Domestic Interiors

Prize: J. R. Davidson, West Los Angeles, for the Stothart residence, Santa Monica.

Mentions: Gregory Ain, designer, Los Angeles, for residence of Mr. and Mrs. Sidney Brown, Los Angeles;

SAN FRANCISCO-OAKLAND

BAY BRIDGE
TERMINAL

**LATHING AND
PLASTERING**

by

**LEONARD
BOSCH**

PLASTERING CONTRACTOR

280 13TH STREET
SAN FRANCISCO

Telephone Market 6545

SISALKRAFT
REG. U. S. PAT. OFF.

"More than a
building paper"

THE SISALKRAFT CO.

205 West Wacker Drive
(Canal Station) Chicago, Ill.
55 New Montgomery Street
San Francisco, Calif.

**Pacific
Manufacturing
Company**

High Class Interior Finish
Quality Millwork

142 Sansome St. 6820 McKinley Ave.
San Francisco Los Angeles
GARfield 7755 THornwall 4196

1315 Seventh Street, Oakland
GLencourt 7850



CLIENTS will bless you for installing the Wesix "49'er" ELECTRIC BATHROOM HEATER. But *try it first in your own home.* Certain that you will like its forty-nine inches of INSTANT RADIANT HEAT and QUICK CIRCULATING HEAT, we are offering this smart new heater at *factory cost to architects*, for personal use! Limit one heater per architect. List price \$21.50. Please write on your regular letterhead, to: **1018 WESIX BLDG., SAN FRANCISCO**



Robert Hiden, designer, Los Angeles, for bachelor's apartment, Los Angeles.

Shops

Prize: George Howe, architect, Philadelphia, for the Evening Bulletin Building, Philadelphia.

Mention: Clarence Saymon, New York, for Marty's Beauty Center, Rockville Center, N. Y.

Stores

Prize: Nimmons, Carr & Wright, architects, Chicago, for Sears and Roebuck Building, Baltimore, Md.

Commercial Interiors

Prize: Walker and Gillette, architects, New York City, for non-breakable Herculite glass doors at 40 Wall Street, New York.

Mentions: Amos Parrish and Company, Inc., New York City, for Amos Parrish and Company offices; J. R. Davidson, West Los Angeles, for Sardi's Restaurant, Hollywood.

Hotels

Prize: Harbin F. Hunter, architect, Los Angeles, for Lindy's Restaurant, Los Angeles.

Manufacturing Plants

Prize: Albert J. Daniels, Shrewsbury, Massachusetts, for W. H. Nichols Building, Waltham, Mass.

Educational Buildings

Prize: Alfred Kastner, architect, Washington, D. C., for Community Building, Jersey Homesteads, Hightstown, New Jersey.

Mention: Richard J. Neutra, architect, Los Angeles, for Ralph Waldo Emerson Junior High School classroom, Los Angeles.

Institutional Buildings

Prize: Victorine and Samuel Homsey, architects, Wilmington, Delaware, for Children's Beach House, Lewes, Del.

Miscellaneous

Prize: Reinhard and Hofmeister, architects, New York City, for entrance doors, Rockefeller Center Branch of Chase National Bank.

Mention: Gustav Jensen, designer, New York City, for all-glass table executed by Harriton Carved Glass Co., New York.

Pitcher

Improved Disappearing Doors Save 20% Space

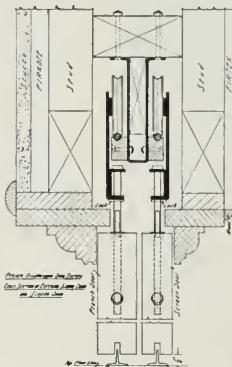

Joins with a 3 3/4" stud wall . . . steel studs . . . adjustable steel and wood track. Can be used for screen doors in connection with French doors. Send for detail drawing.

E. C. Pitcher Co.

461 Market Street
San Francisco



HERRICK IRON WORKS

STRUCTURAL STEEL
REINFORCING STEEL

18TH AND CAMPBELL STS.
OAKLAND, CALIF.
Phone GLEncourt 1767

FORDERER CORNICHE WORKS

Manufacturers of

- Hollow Metal Products
- Interior Metal Trim
- Elevator Fronts and Cabs
- Metal Plaster Accessories
- Sanitary Metal Base
- Metal Cabinets
- Flat and Roll Metal Screens
- Commercial Refrigerators

269 POTRERO AVE.

San Francisco, Calif.

HEmlock 4100

Donovan Automatic Awning Type Windows

Give 100% natural ventilation and day-lighting control

UNIVERSAL WINDOW COMPANY

Berkeley, California

"AMERICAN MARSH" Redi-Vac Vacuum Heating Pump

Send for Bulletin 441

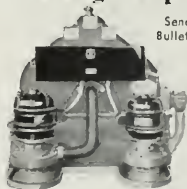

SIMONDS MACHINERY CO.

San Francisco
816 Folsom St.

Los Angeles
455 East Fourth St.

EXPOSITION NUMBER

The February ARCHITECT AND ENGINEER will picture Treasure Island as it has never been pictured before . . .

Special Photographs
Special Articles
Cover De Luxe in
Exposition Colors

Arthur Brown, Jr., chief of the Architectural Department of the Fair, will be Guest Editor. Contributors will include Mr. Brown, Will P. Day, Mark Daniels, Lewis P. Hobart, Wm. Merchant, Jess Stanton, John Gould and many others.

Independent Iron Works

Structural Steel
Ornamental Iron
Steel Service Stations
Steel Tanks
Standard Steel Mill Buildings
Bridges

821 Pine Street Oakland

**Clinton
Construction Co.**
of California
General
Contractors

923 Folsom Street
San Francisco
SUtter 3440

MASS FAMILY HOUSING

Taking the initiative in what promises to be the broadest single undertaking in low cost housing yet attempted by private industry, representatives of the country's leading building materials manufacturers are completing plans for a nation-wide program to provide housing for families in the \$1200 to \$2000 a year income class.

The movement is sponsored by the National Lumber Manufacturers Association and the National Retail Lumber Dealers Association. The plan is intended to make available the latest in living accommodations to the mass of American families able to pay only \$25 to \$35 a month for shelter.

In a recent Washington conference Government housing officials participated, along with representatives of the plumbing, heating, insulation, refrigeration, cement, electrical, lumber, copper, brass, millwork and allied industries. Present also were representatives of housing research foundations, contractors and realty dealers.

Upon completion of final details it is planned to launch a campaign on a nation-wide scale to stimulate the construction of homes in every community, making them available chiefly through local contractors, lumber and building supply dealers.

Plans so far worked out indicate a variety of home styles will be made available, flexible as to size from three to seven rooms, and which can be adapted detached, semi-detached and row-house types. Demonstration projects already are planned in a number of communities.

The entire undertaking will be initiated locally with the aid of private capital. The only Federal agency which might enter into the picture is the Federal Housing Administration, whose mutual mortgage insurance plan may be adopted in financing the sale of the homes to individual families.

YOUNG ADDRESSES BUILDERS

Walker R. Young, Supervising Engineer for the United States Bureau of Reclamation, reviewed the progress of work on the Central Valley Project in a talk before the annual meeting of

COMFORT

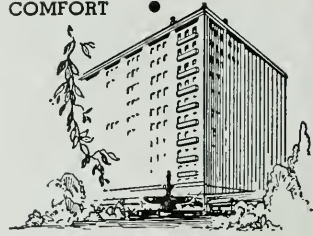

New HOTEL CLARK in Downtown LOS ANGELES

Convenience is another offering of this hotel. Whether on business or pleasure bent, the Hotel Clark makes an ideal "base of operations," as well as a restful "billet," at the end of the day's "campaign." Good Food, naturally. And moderate charges, as well as for room accommodations, give final significance to assuring word — COMFORT

Single from \$2.50
Double from \$3.50

ROOMS
555
BATHS

Fifth and Hill

P. G. B. MORRIS, Manager

ANDERSON & RINGROSE

General Contractors

320 Market Street, San Francisco
Phone GARfield 2245

HIGH GRADE MILLWORK
AND INTERIOR FINISH
SASH AND DOORS

LANNOM BROS. MFG. CO.

FIFTH AND MAGNOLIA STREETS
OAKLAND, CALIFORNIA
Telephone: TEmplebar 3663

MULLEN MFG. COMPANY

BANK, STORE AND OFFICE
FIXTURES—CABINET WORK
OF GUARANTEED QUALITY
CHURCH SEATING

Office and Factory:
60-80 RAUSCH ST., Bet. 7th and 8th Sts.
San Francisco
Telephone UNDERhill 5815

G. P. W. JENSEN & SON

Building Construction

320 Market Street, San Francisco
Phone: GARfield 2444

DINWIDDIE CONSTRUCTION COMPANY

•
BUILDERS

•
CROCKER BUILDING
SAN FRANCISCO

Carl T. Doell Co.

*Plumbing
Heating*

Plumbing Contractor
Veterans Memorial Building
Oakland

467 21ST STREET
OAKLAND

Telephone GLencourt 8246

the Northern California Chapter of the Associated General Contractors of America, Saturday, December 10 in San Francisco. He said contracts have been awarded in excess of \$40,000,000 and that more than 2,000 persons now are employed by the Bureau of Reclamation and its contractors.

On the Kennett Division at the northern end, foundation excavation is proceeding on both abutments of the Shasta Dam site near Redding and in a temporary diversion channel along the Sacramento River. Construction also is under way on a temporary railroad by-pass tunnel through the west abutment, and on a warehouse and storage yard at Coram downstream from the dam site.

The Government camp three miles east of Shasta Dam is completed and occupied. The general contractor's camp is nearing completion in the canyon just below the dam site, with the contractor's office and one dormitory occupied and the mess hall operating.

A contract has been executed with the Southern Pacific Company for relocation by the United States of 37 miles of main line railroad north of Redding on a new 30-mile route around the future Shasta Reservoir. First construction on the relocated line is under way on a 4,346-foot railroad bridge across the Sacramento River at Redding. Contracts also have been awarded or bids received for half of the 30 miles of railroad grading, four tunnels and two additional bridges.

On the Delta Division, the first four miles of the Contra Costa Canal are completed from Rock Slough to Oakley, construction is proceeding on the next eight-mile section between Oakley and Antioch, and contracts have been awarded for building an additional eight miles of canal past Antioch and Pittsburg and for building four pumping plants near Oakley. Field location of the canal is completed by Bureau of Reclamation engineers for the entire 46 miles to near Martinez.

Engineering investigations are continuing on the San Joaquin Pumping System in the northerly half of the San Joaquin Valley.

Louis C. Dunn, Inc.

GENERAL
CONTRACTORS

Monadnock Building
San Francisco

Phone: DOuglas 4632

Empire Construction Co., Ltd.

Builders



RUSS BUILDING
SAN FRANCISCO
Sutter 2989

Smith

Lumber Company

WHOLESALE - JOBBING - RETAIL
FACTORY AND BUILDING LUMBER
PLYWOODS - ROOFING

DISTRIBUTING YARDS

San Francisco

Oakland

4th & Channel
Market 0103

19th Ave. &
Estuary
FRuitvale 3174

YOUR INQUIRIES SOLICITED

JOSEPH MUSTO SONS-KEENAN COMPANY

MARBLE
and
ONYX

535 NORTH POINT STREET
SAN FRANCISCO
1801 S. SOTO STREET
LOS ANGELES

ABBOT A. HANKS, INC.
Engineers & Chemists

INSPECTING — TESTING — CONSULTING
CONCRETE • STEEL • MATERIALS
CHEMICAL AND TESTING
LABORATORIES
• RESEARCH AND INVESTIGATION •

TESTS OF STRUCTURAL MATERIALS
DESIGN OF CONCRETE MIXES
SHOP AND ERECTION INSPECTION OF
STRUCTURES AND EQUIPMENT
INVESTIGATION OF STRUCTURES
AND MATERIALS
TESTS AND INVESTIGATION OF
FOUNDATION SOILS
FIRE RESISTANCE AND INSULATION
TESTS

624 Sacramento Street, San Francisco

Phone Garfield 1164

Hunter & Hudson

Consulting Engineers
DESIGNERS OF HEATING
AIR CONDITIONING
VENTILATING AND WIRING
SYSTEMS, MECHANICAL
AND ELECTRICAL EQUIP-
MENT OF BUILDINGS

41 SUTTER STREET
ROOM 710

San Francisco California

CEMENTEX!

Specified for

Stucco and Concrete
Will water-proof and
beautify!

Recent users

Hayward High School
Shenstone Apartments
470 Mandana, Blvd., Oakland

FRANK W. DUNNE CO.

41st and Linden Oakland

VAUGHN - G. E. WITT Co.

Manufacturers and Distributors

Pump Governors	Oil Heaters
Safety Pump Governors	Relief Valves
Automatic Gas Regulating Valves	Oil Burner Governors
Gas Burning Equipment	Oil Burners
Vacuum Pump Governors	Oil Pumping Sets
Vacuum Regulating Valves	Oil Valves
Continuous Flow Steam Traps	Oil and Steam Strainers
Thermostats	Duplex Oil Pumps
Reducing Valves	Rotary Oil Pumps
	Boiler Feed Pumps
	Water Heaters
	Boiler Feed-Water Regulators

4224-28 Hollis St., Emeryville, Oakland

**THE
HERRMANN SAFE CO.**

MANUFACTURERS AND DEALERS

OF

FIRE AND BURGLAR PROOF
SAFES AND VAULTS, SAFE-
DEPOSIT BOXES, ETC.

200 HOWARD STREET

SAN FRANCISCO

Garfield 3041 - 3042

**REPUBLIC STEEL
CORPORATION**



Manufacturers of

ENDURO Stainless Steel; TON-
CAN Copper Molybdenum Iron
Sheets and Pipe; and Steel Pipe,
Sheets and Reinforcing Bar for
every building purpose.

Write for information

Rialto Building, San Francisco, Calif.
Edison Building, Los Angeles, Calif.
White-Henry-Stuart Bldg., Seattle, Wash.

**VERMONT
MARBLE
COMPANY**

Producers and Finishers

of

Domestic and Imported
Marbles

San Francisco
Los Angeles
and
Tacoma, Wash.

Robert W. Hunt Company

ENGINEERS

Inspection - Tests - Consultation

Schools and Other Structures
Are Built as Designed

*When Construction Materials are
Inspected at point of Manufacture
and during Erection by*

ROBERT W. HUNT COMPANY

*Cement, Concrete, Chemical, Metallurgical,
X-Ray and Physical Laboratories*

Chicago - New York - Pittsburgh
Los Angeles - All Large Cities
San Francisco, 251 Kearny Street

**JOHN
CASSARETTO**

— Since 1886—And Still Active—

Building Materials

READY MIX CONCRETE
ROCK - SAND - GRAVEL - LIME
CEMENT - PLASTER - MORTAR
METAL LATH - WOOD LATH
STUCCO - WIRE NETTING

Service Unexcelled

Bunkers

Sixth and Channel, San Francisco
Phones: Garfield 3176, Garfield 3177



MERCURY PRESS

We Print
The ARCHITECT and
ENGINEER

*"A Thing of Beauty
Is a Joy Forever"*

942 HOWARD STREET
SAN FRANCISCO

**FINE WATER COLORS
AND PAPERS
FOR ARCHITECTURAL
RENDERINGS**

**H. S. CROCKER
COMPANY, Inc.**

720 MISSION STREET
MARKET STREET AT SECOND
SAN FRANCISCO

**THE TORMEY
COMPANY**

GENERAL PAINTERS
AND DECORATORS

Phone UNderhill 1913

563 FULTON STREET
San Francisco



ARCHITECT AND ENGINEER

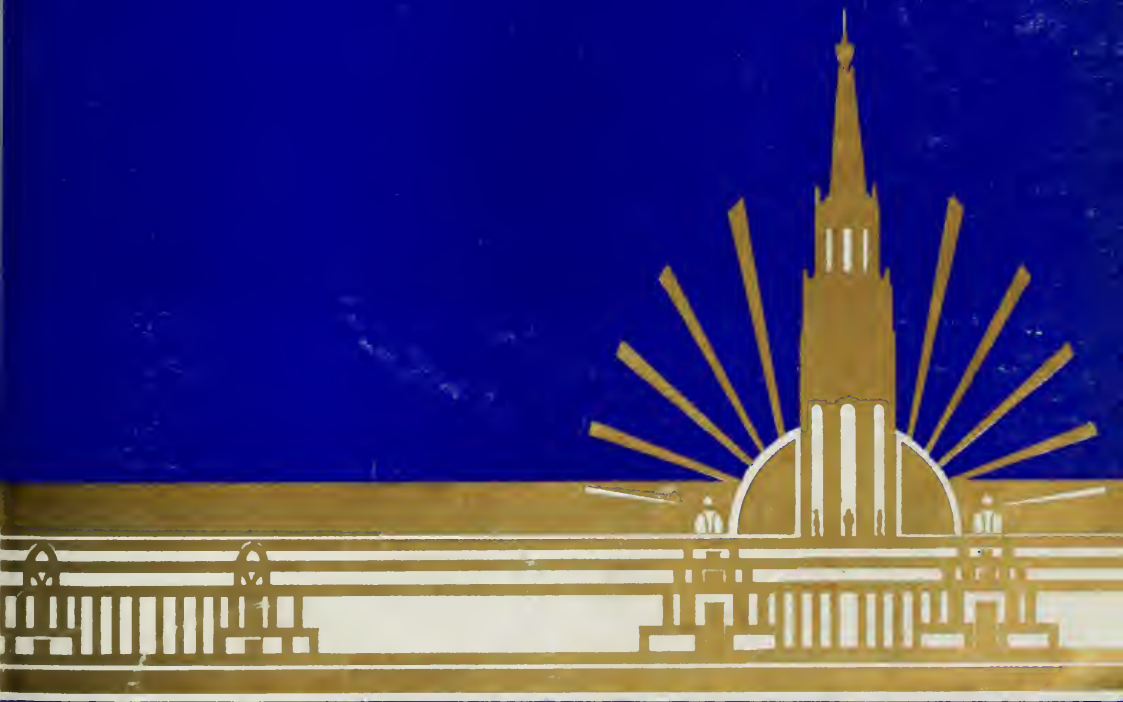

FEBRUARY 1939

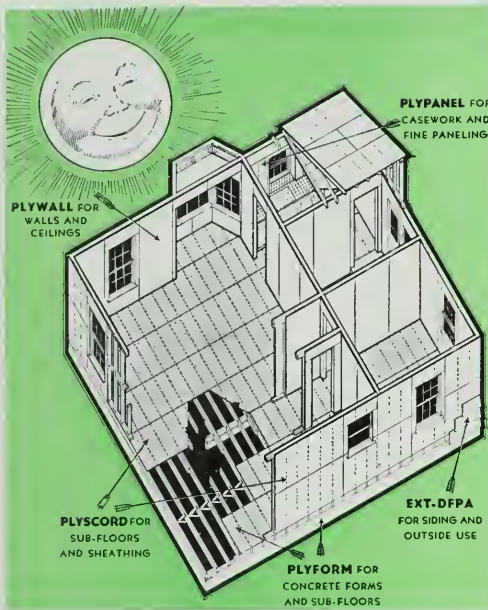

dri-bilt
WITH PLYWOOD

assures stronger,
more rigid,
more durable
construction

... GREATER
CLIENT
SATISFACTION

DRI-BILT with Douglas Fir Plywood is a method of construction adaptable, all or in part, to any house plan. It's ideal for homes where your client's dollars must be stretched to meet his desires—ideal for homes where strength, durability and beauty are primary considerations. In DRI-BILT with plywood construction, you specify the proper grades of these big standardized panels for sheathing, sub-flooring, exterior siding, interior walls and ceilings, casework and fine paneling—even for concrete forms.

This DRI-BILT with plywood method reduces building time, frequently as much as 6 weeks. Hundreds of gallons of water are eliminated from every job, which means no waiting for walls and ceilings to dry out. Construction is *bone dry* from start to finish. Also—your finished structure is stronger, more rigid, more durable than when built by traditional methods.

Speedy DRI-BILT construction shortens your supervisory work, often by weeks. Yet you can give your client more house for his money. There is a considerable saving on labor because plywood panels reduce handling, cutting and fitting to a minimum. Savings in time save interest cost. Best of all, the owner has a built-to-last home of which he can boast proudly to his friends. He can finance it conveniently, too. The F. H. A. has accepted Douglas Fir Plywood for home construction, and its use is approved in the Uniform Building Code.

You'll find it easy to specify the right type of Douglas Fir Plywood for every purpose because today every grade is trade-marked. Study the trade-marks below—they make identification easy. Sweet's Catalog contains complete data on Douglas Fir Plywood. But for special new information on DRI-BILT with plywood construction, mail the coupon below.

**DOUGLAS FIR
PLYWOOD**
Real Lumber
**MADE LARGER, LIGHTER
SPLIT-PROOF
STRONGER**

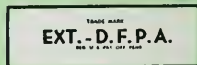

DOUGLAS FIR PLYWOOD ASSOCIATION, Tacoma Building, Tacoma, Washington
Please send me FREE data on DRI-BILT Douglas Fir Plywood construction.

NAME.....
ADDRESS.....
CITY..... STATE.....

RUNNING FIRE

by
MARK DANIELS, A.I.A.

Shut Your Mouth and Open Your Eyes

Is a good slogan for February eighteenth. All this pother about four o'clock closing is a product of jealousy on the part of our super-cisors, who want to get in on the just fame of the ten o'clock opening. Anyhow, that four o'clock closing hasn't applied to the offices of some of us architects whose fees for their work on Treasure Island are needed to pay electric light bills.

But it has been more than worth the effort. Those courts, palaces and towers will thrill everyone who sees them and if the eyes of Arthur Brown, Lewis Hobart, Tim Pflueger, Bill Merchant and Ernest Weihe are red from working late hours, they will be redder when they hear the shouts of approval on opening day.

Nor will they be the only group to reap the reward of high appreciation. That corps of men, headed by Charlie Purcell, who came to the California Commission after completing the trifling job of building the Bay Bridge, have constructed fifteen buildings in a period of a little more than fourteen months. Yes, Ralph Tudor, Claude Cooper and Clarence Seage will be red-eyed too—and happy. Charlie Purcell has been red-eyed from overwork for so long that he is used to it.

Of course, those who made the project financially possible don't count. And besides, presidents, executive officers and the like have their names blazoned on the pages of the dailies, morning and evening, but this item (and this number) is intended to give credit to the architects, landscape architects, artists and sculptors who also serve, but whose names, unfortunately, are kept in obscurity by the press.

So, on February eighteenth and for many days thereafter, keep your eyes open, for you are going to see something.

* * *

Not A Chinaman's Chance

Several of the clubs in town have been seeking headquarters on the Island. Since such institutions would have no special source of revenue, such as admission charges, sale of ice cream or side shows, they

could pay no such ground rentals as were demanded by the Exposition Company. When interviewed, with the idea of getting low cost locations, the Exposition officials said, "Not a Chinaman's chance," but they were wrong on two counts.

The Family Club, with characteristic foresight, went out for a Chinaman's chance and got it. They have the top floor over the administration offices of the Chinese Village at the head of the main promenade of the Gay Way. The Chinese Factors have installed a bar and will supply all service and equipment. The arrangement is as near perfect as could be desired.

How is that for a Chinaman's chance?

* * *

Thoughtless

No one gainsays the pleasure of reading the Sunday supplement at a late breakfast. The pleasures and pastimes of the night before make the reading of the business pages a bit heavy and, in some instances, fearful. What most of us want is light, highly illustrated articles on rose gardens, frolicsome zebras, little lambs on the lawn and children playing blind-man's-buff, not high mountain peaks with climbers hanging on by their eyebrows, autos falling off bridges or ships exploding at sea.

But we can stand a little of this without spilling the coffee. What does seem most cruel, however, is the increasing number of pictures of reptiles, such as crocodiles, lizards, alligators, wriggling across the pages of these Sunday supplements. Why can't they print these on Saturday? Why must they always come out on the morning after Saturday night?

Oh, well, I suppose it is just another bit of thoughtlessness.

* * *

Coals of Fire

We heap coals of fire on our own heads despite the odor of burning bone. Recently, I have heard a number of complaints that restaurants in the neighborhood of my office stay in business but a short time although there is little chance to get a table in one at noon time. Most of us are bitter against the restaurateur and say we'll join a club, but I have come to the con-

clusion that the fault lies with the patron.

Yesterday I squeezed to a table in time to sit down before there was another lap at it. At a table to the left sat a couple studying the menu. When I had finished eating, that couple were still studying the menu and I concluded that the reason restaurant keepers lost money was because their patrons could not decide what they wanted to eat before the rent ate up all the profits.

And to this my Editor adds:

Down near the new terminal station half a dozen restaurants have started in business since the inter-urban train service began. The proprietors are seeking commuter business—patronage of the people who used to eat on the ferry boats. But it's going to be hard sledding for some of these coffee shops if what I have seen is any criterion. While eating my ham an' the other morning, I couldn't help noticing an elderly woman sprawling over a generous part of the counter while she sipped her coffee and smoked a cigarette. The Lord knows how long she had been there. When I left she was still puffing her cigarette and monopolizing a godly portion of the table. Near by two girls, probably stenogs, were having toast and coffee; another dame, a glass of coke and a cigarette; a man next to me was dunking doughnuts. How can there be any profit in such patronage as this and how can these people do half a day's work on such nourishment or lack of nourishment? It's beyond me.

* * *

Mental Jitterbugs

There is a type of man who is never at ease mentally. He jumps from subject to subject like a grasshopper in a wheat field, with about the same results. He stays with one line of thought only long enough to disfigure it before he breaks into the general conversation around him with a fragment of extraneous thought.

Such people are more trying than golf fans, for they never run down. The practice should be discouraged.

If it is indulged to maturity it results in a sort of permanent intellectual eczema. Perhaps this page should be condensed to a single paragraph.

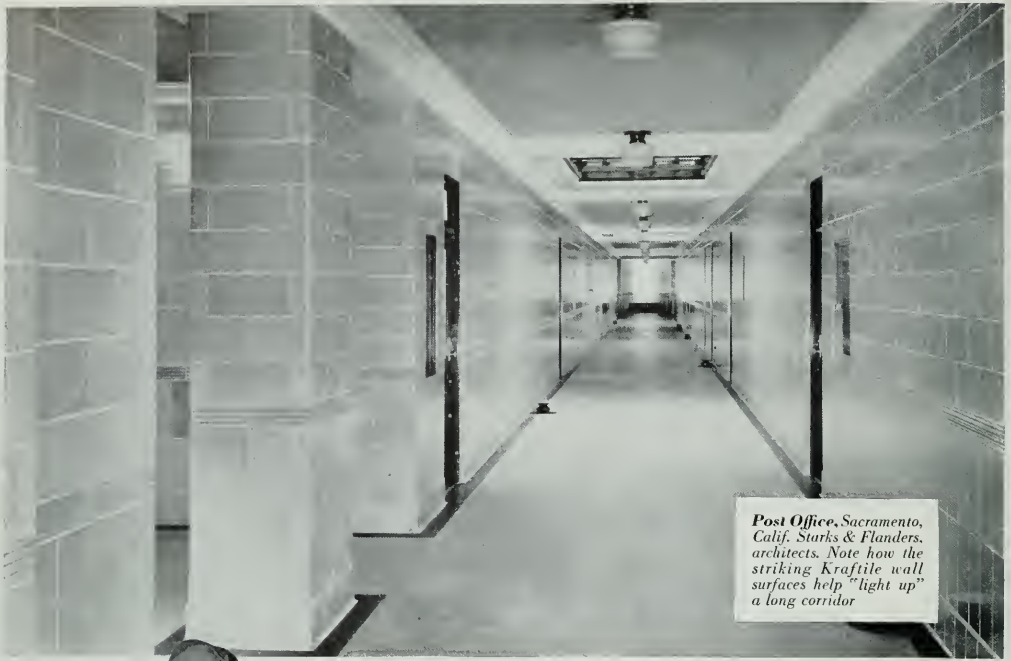

Post Office, Sacramento, Calif. Starks & Flanders, architects. Note how the striking Kraftile wall surfaces help "light up" a long corridor



PARTITIONS ERECTED AND ONE SIDE TILED ALL IN ONE OPERATION!

*One-third less labor to construct... no upkeep cost
... greater light diffusion... brilliant modern
wall beauty with Kraftile Terra Cotta Wall Units*

With Kraftile Wall Units, only one side of a partition needs finishing. The other side automatically "tiles itself" with beautiful, permanent Kraftile.

A glazed terra cotta partition like this actually requires one-third less labor to build than an average wall. And you've just *one* craft to deal with on the job.

Upkeep cost of the glazed side is practically nil. Nothing but an occasional cleaning is needed. The Kraftile glazed

surface is higher fired than even ordinary tile. It resists the hardest kind of scraping. Is fireproof and stain proof. And the color of its beautiful semi-matt finish cannot fade.

Each Kraftile Wall Unit is *precision-sized* within 1/16 inch. Standard sizes and shapes can be used to build any wall.

Write for complete information. Our Engineering and Interior Decoration staff will gladly cooperate with you in any way. Mail coupon today.

FREE HANDBOOK TO ARCHITECTS AND BUILDERS

KRAFTILE COMPANY — Niles, California
Please send me without cost or obligation "Handbook of Specifications and Suggestions on Glazed Terra Cotta Wall Units" ()
Please have service representative call ()

Name _____

Address _____

City _____

State _____

KRAFTILE TERRA COTTA WALL UNITS

THE ARCHITECT AND ENGINEER

The Architect & Engineer

Fred W. Jones, Editor

Mork Daniels, A. I. A. Associate Editor

Edgar N. Kierulff, Assistant Editor

CONSULTING BOARD
OF EDITORS

Architectural—

- Arthur Brown Jr.
- Frederick H. Meyer
- Timothy L. Pflueger
- Will G. Corlett
- Harry Michelsen
- John J. Donovan
- Lewis P. Hobart
- David C. Allison
- Gordon B. Kaufmann
- Harris C. Allen
- Glenn Stanton
- Paul R. Hunter
- C. H. Alden

Engineering—

- H. J. Brunner
- L. H. Nishkian
- William Adrian
- Wm. H. Popert
- Homer N. Hadley
- John J. Gould
- Geo. E. Atkins

Advertising Manager—

- J. Leslie Meek

Architects' Reports—

- Vernon S. Yallop

THE ARCHITECT AND ENGINEER, INC., 68 Post Street, San Francisco, EXbrook 7182. President, K. P. Kierulff; vice-president, Frederick W. Jones; secretary, L. B. Penhorwood. Los Angeles office, 832 W. Fifth Street. Published on the 12th on each month. Entered as second class matter, November 2, 1905, at the Postoffice at San Francisco, California, under the Act of March 3, 1897. Subscriptions, United States and Pan America, \$3.00 a year; Foreign countries, \$5.00 a year; single copy \$.50.

● Contents for February, 1939

COVER DESIGN

by J. E. Stanton, Chief of Color, G. G. International Exposition

Text

RUNNING FIRE	1
Mark Daniels, A. I. A.	
THE EXPOSITION—A Creditable Accomplishment for San Francisco Architects	17
Fred W. Jones	
THE ARCHITECTURAL PLANNING OF THE EXPOSITION	19
Arthur Brown, Jr., Chairman of the Board of Architects	
BIRTH OF A FAIR—How Treasure Island was Conceived and Developed	23
Will P. Day, Director of Works	
ROMANCE—The Court of Reflections and the Court of Flowers	25
Lewis P. Hobart, A. I. A.	
WIND BREAKS—The Portals of the Pacific	29
Ernest E. Weihe, Architect	
TEMPLES OF THE EAST	33
William Gladstone Merchant, Architect	
COLOR AND LIGHT—Treasure Island Brilliant Beyond Words	39
J. E. Stanton, Chief of Color	
SCULPTURE	41
LANDSCAPING—Beautification of Grounds and Gardens	43
Mark Daniels, A. I. A.	
ENGINEERING DESIGN—Structural Features of the Exposition	45
John J. Gould, C. E.	
PUBLIC BUILDINGS—State and County Group at Treasure Island	51
PLYWOOD—Eight Million Square Feet at Treasure Island	53

Plates and Illustrations

TOWER OF THE SUN , Arthur Brown, Jr.	18
COURT OF FLOWERS , Lewis P. Hobart	25-27
PORTALS OF THE PACIFIC , Ernest E. Weihe	28-30
ADMINISTRATION BUILDING , Geo. W. Kelham and Will P. Day	31-32
TEMPLES OF THE EAST , Merchant and Maybeck	33-34
PACIFIC HOUSE , Wm. G. Merchant	35
PACIFICA , Court of the Seven Seas, Timothy L. Pflueger	36
CALIFORNIA COLONNADE , Timothy L. Pflueger	37
CHINESE VILLAGE , Mark Daniels	42
FEDERAL BUILDING , Timothy L. Pflueger	54

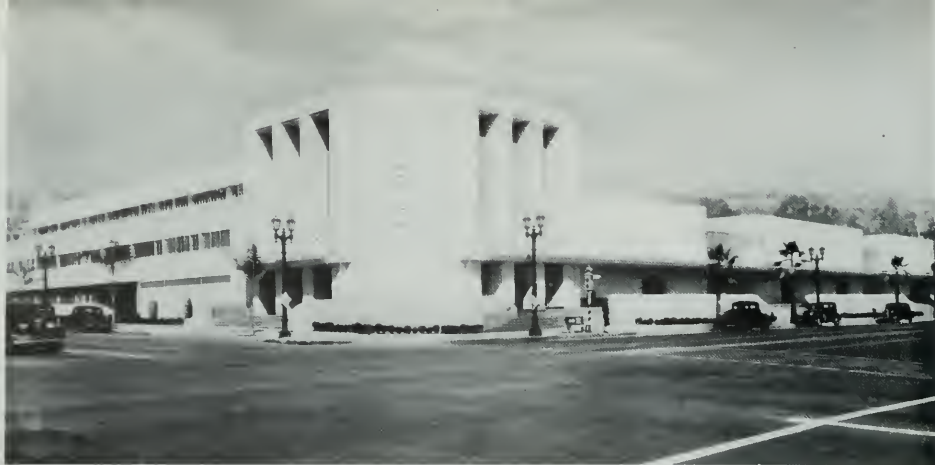

N. B. C.'S LATEST STUDIO IS PAINTED A SOFT GREEN TO BLEND WITH SKY AND SHRUBBERY AND REDUCE GLARE

Air Conditioned

Hollywood's New Radio City

GAS-FIRED air conditioning of the most successful type is the important feature of the ultramodern National Broadcasting Company studio in Hollywood, completed last November. The most advanced developments in broadcasting engineering are incorporated in the design of this studio, described as the "ideal plant." The air conditioning system was designed especially for this type of structure.

Since the entire building is under accurate thermostatic control, the steam requirements change considerably from day to day and from hour to hour in accordance with outside temperature. For this reason, natural gas, with its great flexibility, was selected as the fuel which could most perfectly meet these wide fluctuations in steam demand. The installation supplies two low pressure firebox steel boilers, each having a capacity of 9,500 sq. ft. of steam radiation. The boilers are fired with Nemec vertical fireclay tube and cap type gas burners, installed in a horizontal plane in the position normally occupied by the grates.

Other features of the boiler installation include the control apparatus on each boiler, which consists of a gas valve and secondary air inlet louvers, both controlled by a very sensitive diaphragm, which is operated by steam pressure. Both gas and secondary air are throttled from full open fire to a set minimum fire as the steam requirement decreases. If the demand falls below this set minimum fire, the valve snaps to the close position, thus preventing any back fire in the mixers. Thermocouple type safety pilots and low water cut-off also operate through the same control valve to protect the boiler against pilot failure or lack of water.

Properly conditioned air is conveyed to the various studios and rooms through an elaborate duct system that has been designed to trap and prevent transmission and regeneration of noise. The air in all conditioned spaces is completely changed eight times an hour.



CORNER OF THE STAGE OF STUDIO D, N. B. C.'S NEW HOLLYWOOD RADIO CITY. THE GRILLING HIDES A HUGE AIR DUCT

Flash!

..NEW INSULATING INTERIOR FINISH
 MAKES FULL PROVISION FOR
 EXPANSION AND CONTRACTION

*Makes Beautiful Interiors . . .
 Applies Direct to Open Framing
 With Minimum Cutting and Sawing!*

THE Key Joint Unit, a new product by Celotex, answers the problems architects have met in trying to combine insulation with interior finish! When you use Key Joint Units, you obtain beautiful modern interiors—with a full three-quarters of an inch of efficient insulation! Investigate this *brand new* self-aligning insulating interior finish now! Five standard sizes provide infinite variety of pattern. Fits 16" centers—jamb thickness—applied direct to open framing! Proofed against termites and dry rot by the exclusive, patented Ferox Process—and guaranteed in writing for the life of the building.* Mail coupon today!

*When issued, applies only within the boundaries of Continental United States.



Infinite variety of pattern is possible with 5 standard sizes—16" x 16", 16" x 4', 16" x 8', 4' x 4', and 4' x 8'! Go up fast on open framing—jamb thickness—no cutting or sawing except at room borders and openings!

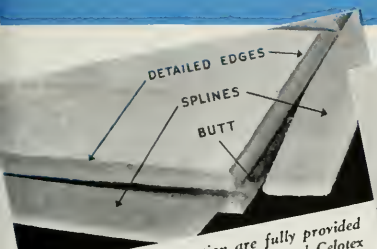

Expansion and contraction are fully provided for by spline joints at every edge of each Celotex Key Joint Unit. No open cracks visible at any point. 3/4" thickness insures exceptional rigidity.



Nail heads are hidden in the depth and shadow of the joint, getting a good grip on the material and on the studs. Large spans require intermediate nailing with 1 3/4" finishing nails.

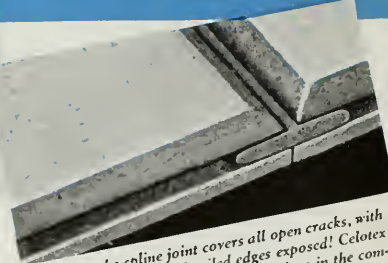

See how the spline joint covers all open cracks, with only the beautifully detailed edges exposed! Celotex Key Joint Units go up fast—save days in the completion of important jobs.

The word Celotex is a brand name identifying a group of products marketed by The Celotex Corporation and is protected as a trade mark shown elsewhere in this advertisement.

CELOTEX

REG. U. S. PAT. OFF.

KEY JOINT UNITS

Sales Distributors Throughout the World

Copyright 1938, The Celotex Corporation

THE CELOTEX CORPORATION
 919 N. Michigan Ave., Chicago, Illinois
 Please send your new booklet giving full information on Celotex Key Joint Units.

ME 2-39

Name _____
 Address _____
 City _____
 County _____ State _____

The Rose — a toast to the queen

by *Berniece Ashdown*
Landscape Architect

I PROPOSE a toast to Her Majesty the Rose . . .

Through all the centuries of political and economic upheaval, her line of queenship has retained its title and crown. From the simple, soft petaled rose of antiquity, down through the decades to the modern generation of prim sophisticates, the rose has held her place of esteem, has played a prominent part in the world's historical and social events.

Legend states that as an emblem of Love and Beauty, it was dedicated to Venus; of Danger and Fugacity, to Cupid; of Youth to Aurora.

Her title was acknowledged in the earliest herbals and engraved on the objects of art of antiquity. The rose is the national emblem of England.

It is probably the best known and best loved flower in the world and the sentiment attached to the rose can not well be replaced by any other flower.

Cities all over the world have elaborate public rose gardens, many of them exquisite beyond description and most private gardens, no matter how small, boast a rose or two.

Since roses grow best in an open situation, with the ground left bare beneath them, most rose gardens are laid out in geometric patterns. A good plan is to make the beds about twelve feet wide with two feet six inches of turf between. The plants should be 25 to 30 inches apart.

It is generally considered best to plan roses early in the Spring before the buds have pushed out in order to make the most of the long growing season. Fall planting is inadvisable unless the plants are dormant since moving them while they are still in leaf is often injurious.

A southeastern exposure is excellent for roses, as it allows abundant sunshine as well as a free circulation of air, both of which are vital to successful rose growing.

As is true of most plants, the cultural requirements of roses in different climates varies a great deal, but there are many general rules which hold true regardless of location. It will be found also that the same variety of roses will act differently in mild climates than in colder sections.

Roses like fertile, well drained soil which is at least eighteen inches deep. They need an abundance of water and frequent cultivation. Never spray roses when the water will stand on the foliage over night as it greatly decreases their resistance to mildew.

Fertilizing is of utmost importance. A good mulch of barnyard manure, or of well balanced commercial fertilizer, rich in nitrogen, should be applied twice a year. A

new mineral fertilizer which was recently put on the market under the name of Mina-Loma is producing phenomenal results. Liquid manures and soot water are often applied to force blossoms.

The hardy varieties of roses are not very susceptible to pests or disease. If, however, they are attacked, immediate attention will soon rid them of their affliction. Green fly and aphids are best controlled with Black-leaf 40. Leaf eating insects may be controlled with arsenic of lead, eight ounces to five gallons of water applied to the under side of the leaves. For mildew, spray with sulphur of potassium, one half ounce to one gallon of water or dust the bushes well with powdered sulphur.

Proper methods of pruning are of tremendous importance. Roses are normally pruned in late winter or very early spring while they are still dormant, yet some growers have found it highly beneficial to prune them again after the first prolific bloom of early summer.

The life of a rose depends upon its new growth and this is determined by the amount of pruning. Hybrid tea roses should be pruned severely, cutting strong shoots within twelve inches of the ground and weak ones to the earth. Hybrid perpetuals or June roses need less. Climbing roses should be pruned to within three or four buds of the main stem.

Hundreds of new roses are being introduced each year. The popular demand for something new accounts for the fact that new varieties are most in evidence. Many of them, however, are unfortunately inferior to some of the older and better established varieties. The wise gardener does not make his selection according to fad but chooses a rose which is resistant to disease, vigorous, has attractive foliage, free blooming habits, and which produces upon a good strong stem, a long pointed bud which will open into a firm blossom of pleasing color and form.

Most modern roses are classed under the following: **hybrid perpetual** (H. P.), a vigorous growing hardy rose, with dull dark green foliage; **tea rose** (T), a less vigorous, spreading bush with glossy pale green leaves which have a delightful tea fragrance; **hybrid teas** (H. T.) represented by most of the new roses and combining the best qualities of the two types mentioned above; **pernetiana**, distinguished by their highly colored golds; **palyantha**, which has abundant foliage and clusters of small flowers; last, the climbers, most of which may fall under the classification above.

It is impossible to list here all the meritorious roses, therefore it is suggested that when selecting this type of flower one should

consult a reliable nurseryman. The latter are always happy to make suggestions and select varieties which are particularly well suited to the locality.

Here are a few varieties worth considering:

WHITE

Bush: Climbing:
Frau Karl Druschi Silver Moon
(H. P.)
K. A. Victoria (H.T.)

YELLOW AND ORANGE

Bush: Climbing:
Golden Emblem (H.T.) Doublebloms (H.T.)
Irish Fireflame (H.T.) Golden Emblem (H.T.)
Joanna Hill (H.T.) Golden Dawn (H.T.)
Ville de Paris (H.T.) Etoile de Feu (H.T.)
Cecil (H.T.)

CREAM AND LIGHT YELLOW

Bush: Climbing:
Golden Ophelia (H.T.) Marechal Niel
Lady Hillingdon (T) Mermaid

*A few hours
a few dollars*
AND

Sealcon

WILL MAKE YOUR BASEMENT

DRY

SEALCON forms a water-resisting seal for basement walls and floors, brick, stucco or any other masonry. Just paint it on, inside or outside, to any wet or dry surface. One coat gives lasting protection . . .

conquers
dampness
and seeping
water. A
perfect
base, or
mixture, for
oil paint.

**EASIER
TO APPLY
THAN PAINT**

ASK DEALER
LISTED
BELOW
ABOUT



Sealcon

GUNN, CARLE & CO.

Distributors

20 Potrero Ave. UNDERHILL 5482
SAN FRANCISCO

Sunburst (H.T.) Mrs. Aaron Ward
 Mrs. Aaron Ward (H.T.)
 (H.T.)

PINK

Bush: Climbing:
 Mme. Butterfly (H.T.) Cecile Brunner (Poly)
 Ophelia (H.T.) Mme. Butterfly (H.T.)
 Dainty Bess (H.T.) Mary Wallace

ROSE

Bush: Climbing:
 America (H.T.) Rose Marie (H.T.)
 Dame Edith Helen Cherclee Pink
 (H.T.) American Pillar

Pink Radiance (H.T.)
 Rose Marie (H.T.)

RED

Bush: Climbing:
 Hoosier Beauty (H.T.) Blaze
 Margaret McGredy Etiole de Holland
 (H.T.) Paul's Scarlet

**WHO DESIGNED THESE BUILDINGS?
 How Good Is Your Memory?**

Underwood Building, south side of Market between First and Second, San Francisco, was designed by—

- (1) Bliss & Faville
- (2) Lewis P. Hobart
- (3) Willis Polk.

Pacific Gas & Electric Building, lower Market Street San Francisco, was designed by—

- (1) Bakewell & Brown.
- (2) Miller & Pflueger
- (3) Frederick H. Meyer.

Royal Insurance Building, Montgomery Street San Francisco, was designed by—

- (1) D. H. Burnham & Co.
- (2) Trowbridge & Livingston
- (3) L. B. Dutton.

Merchants Exchange Building, California Street San Francisco, was designed by—

- (1) D. H. Burnham & Co.
- (2) Meyers & Ward
- (3) Reid Bros.

Oakland City Hall, was designed by—

- (1) Palmer, Hornbostel & Jones
- (2) Reed & Corlett
- (3) John J. Donovan.

Flatiron Building, Broadway, San Pablo Avenue and 16th Street Oakland, was designed by—

- (1) L. B. Dutton
- (2) Wm. L. Woollett
- (3) Reed & Corlett.

Claremont Hotel, Berkeley, was designed by—

- (1) Bliss & Faville
- (2) Wm. L. Woollett
- (3) C. W. Dickey.

Yeon Building, Los Angeles, was designed by—

- (1) Parkinson & Bergstrom
- (2) Reid Bros.
- (3) Hunt & Grey.

Philharmonic Auditorium (before remodeling), Los Angeles, was designed by—

- (1) Chas. F. Whittlesey
- (2) Allison & Allison
- (3) Alfred T. Rosenheim.

(Correct answers on page 66.)

"CONTROL BY JOHNSON"

Throughout the School Systems in Many Cities . . .

In these modern school buildings at Aberdeen, S. D., built at various times from 1921 to date, "Control by Johnson" is accomplished by more than a hundred room thermostats. Uniform temperatures, for health, economy, and convenience, are assured. Johnson automatic temperature control is selected for building after building in the school systems of many cities. Here is evidence that "Control by Johnson" is a dependable and effective money-saver, regardless of the size of building or type of heating plant.

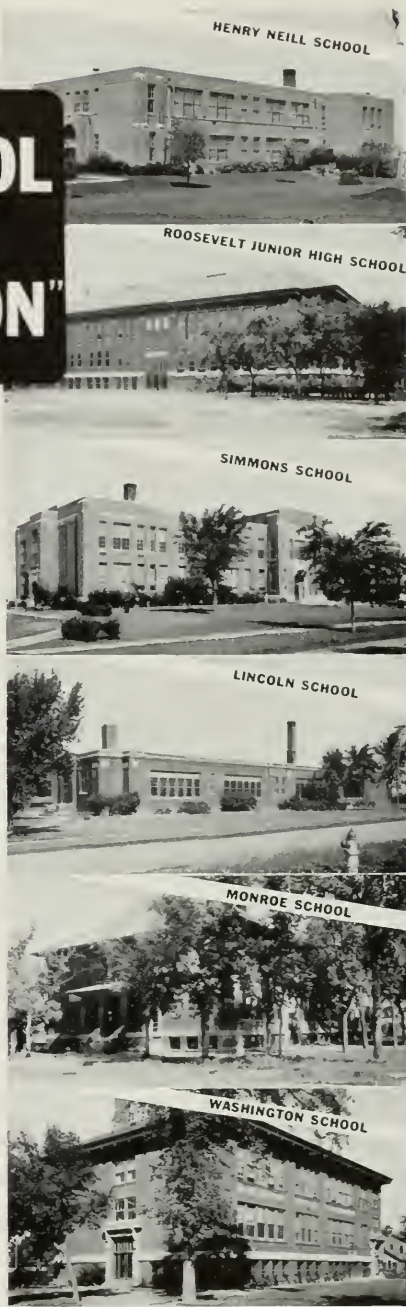

JOHNSON

AUTOMATIC TEMPERATURE AND HUMIDITY CONTROL

JOHNSON SERVICE COMPANY, MILWAUKEE, WIS. AND BRANCHES IN PRINCIPAL CITIES

FREE WATER AT THE FAIR



VIEW OF EXPOSITION ON MAN-MADE ISLAND. SAN FRANCISCO BAY BRIDGE ON RIGHT.

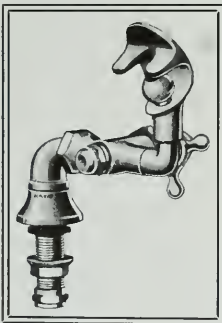

Model 2 K

OVER 200 Haws Drinking Faucets and Fountains are placed in convenient locations on Treasure Island, Golden Gate International Exposition, assuring the many thousand visitors a cool, fresh drink of water, obtainable under every sanitary condition. Haws fountains meet the requirements of the American Public Health Association.

Look for these models at the Fair. Specify HAWS Drinking Faucets and Fountains for public buildings, service stations, playgrounds—they give lasting satisfaction. Sanitary because they have the angle stream.

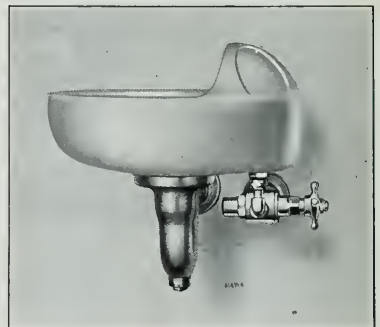

Model 5 B 2

HAWS DRINKING FAUCET CO.

1808 HARMON STREET, BERKELEY, CALIF.

Agents in San Francisco • Los Angeles • Portland • Seattle
Salt Lake City • etc.



Reflections

in the North Lake of the Nations, enhance the beauty of Pacific House, the theme building of the Golden Gate International Exposition, William Gladstone Merchant, Architect. A. Quandt & Sons were the Painters and Decorators for Pacific House, as well as for San Francisco's own Exposition building designed by Clarence A. Tantau, Architect.

Reflections, too, of more than half a century of friendly service by this organization of painting craftsmen . . . years of rich experience through which A. Quandt & Sons have maintained only one standard of workmanship — the finest.

A · QUANDT & SONS 374 Guerrero St.
San Francisco
PAINTERS AND DECORATORS

WORLD PIONEERS IN APPLICATION OF LIQUEUR IN ARCHITECTURAL FIELD



KRAFTILE REPRODUCTION OF ANCIENT FRIEZE



Modeled from earliest known representation of dairying, this frieze reproduced by Kraftile Company, is shown in the exhibit of ceramics at Treasure Island. Handled in three pieces, the modern panel is 8 feet by 22 inches and depicts priests performing ceremonies in honor of the milk goddess.

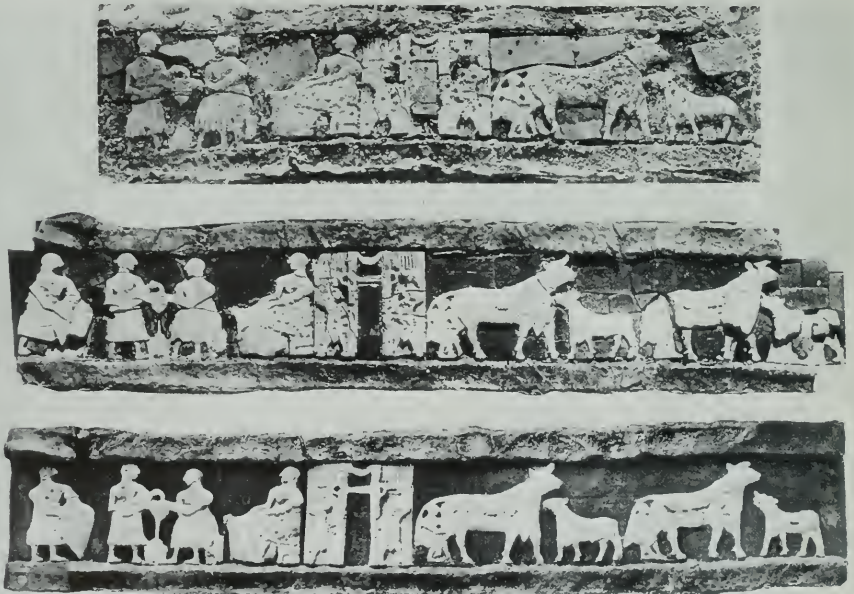

Inlay frieze with limestone figures, earliest known representation of dairying, which was reproduced by Kraftile Company in tile and which will be exhibited among the ceramics at Treasure Island. Top—panel as found. Middle—with parts replaced. Lower—as restored. Scale: about 1/5.

ARTIST DUPLICATES EARLY DAIRY SCENE



Felice Alchieri, sculptor, at work carving in clay early dairying scene exhibited in Ceramic Arts Exhibit at Treasure Island. This panel, with appropriate bronze plaque, and surrounding tile detail, decorates the lobby of the world headquarters of Kraft-Phenix Cheese Corporation recently opened in Chicago. (Picture below.)



AMONG the interesting exhibits of California ceramics at the Golden Gate International Exposition is a panel eight feet long by 22 inches wide, which Kraftile Co. has reproduced the earliest known representation of dairying. A similar panel decorates the main lobby of the general offices in Chicago of the Kraft-Phenix Cheese Corporation with an explanatory bronze plaque containing this inscription:

About 5,000 years ago the Babylonians of Ur worshipped the milk goddess Nin-hur-sag. When her shrine at al-Ubaid was excavated by the Museum of the University of Pennsylvania and the British Museum, on the outer wall was discovered the panel here reproduced. It depicts two calves emerging from a reed pen a man milking from behind the cow as was the custom at that time two men straining milk and pouring it into a spouted jar, another making butter by rolling a jar between his knees, and

a fifth packing it away. These men are priests performing ceremonies in honor of the milk goddess; the scene is the earliest known representation of dairying."

An example of capable craftsmanship coupled with art, this handsome reproduction was modeled on a slab of plaster of paris faced with clay by Felice Alchieri, trained in Turin, Italy, and recipient of several important commissions in California.

Not all the original scene was used, though the scope of the original panel was completely preserved, including the calves leaving their byre. When the bas-relief was complete, the panel was separated into three parts to facilitate handling. The resulting work of art is a credit to the ceramic industry in California and is another example of ability to meet requirements of architects.



CONCRETE

helps express
the swift tempo
of radio

The clean lines of this building symbolize the progressiveness of C.B.S. and Station KNX. These lines were conceived in *Concrete*—the versatile material which brings new freedom to design because it can be molded and textured to the dictates of almost any conception.

Concrete was a happy choice for owner as well as architect—resulting in a fire-safe, earthquake-resistant building of striking character, with low first cost and assurance of minimum maintenance.

Write for just-published booklet, "*The NEW Beauty in Walls of Architectural Concrete.*" which gives interesting examples of complete buildings, textures and detail.

● Studio of Columbia Broadcasting System's Station KNX, Hollywood. Architect, Wm. Lescaze, New York. Associate Architect: Earl Heitshmidt, Los Angeles. Contractor: Wm. Simpson Construction Co., Los Angeles.

PORTLAND CEMENT ASSOCIATION

Dept. N 1-6, 584 Market St., San Francisco, Calif.
Dept. I 1-8, 816 W. Fifth St., Los Angeles, Calif.
Dept. O 1-2, 903 Seaboard Bldg., Seattle, Wash.

*A National Organization to Improve and Extend
the Uses of Concrete*

*Architectural
Concrete*

... combining architectural and structural functions
in one firesafe, earthquake-resistant material

“The Selling Punch”

In the boxing game they call it “the one-two.” We certainly don’t infer you should go out and punch your prospect on the nose (even though you might feel like it some times after he has given the business to your competitor). What we want to call your attention to is the doubly effective complete advertising-selling plan offered by THE ARCHITECT AND ENGINEER and ARCHITECTS REPORTS.

- **Make it easy for your prospect to buy or specify your product**

A series of advertisements in THE ARCHITECT AND ENGINEER will serve to familiarize the architects, contractors, engineers, owners whom you aim to sell, with the advantages of your product . . . break down resistance . . . arouse interest . . . impel favorable action.

- **Follow up your advantage at *the right time***

ARCHITECTS REPORTS will tell you when to intensify your efforts with the right man, when he is in position to place new business . . . by reporting building projects of every description, from the earliest stages of development to the awarding of the last sub-contract.

Other producers and marketers of building supplies (including in all probability your competitors) are *profitably* utilizing one or both of these selling forces. Why not fortify *your* business-getting efforts with this “Selling Punch”?



The ARCHITECT and ENGINEER
Architects Reports

68 POST STREET • SAN FRANCISCO

“Thirty-second Year of Continuous Publication”



TOWER OF THE SUN AND THE SIAMESE CEREMONIAL UMBRELLA
LIGHTING STANDARDS OF THE COURT OF REFLECTIONS OUT-
LINED AGAINST A CALIFORNIA NIGHT SKY

ARTHUR BROWN, JR., ARCHITECT



The Exposition

A Creditable Accomplishment for San Francisco Architects

by Fred W. Jones

WHEN we read the newspapers with their graphic descriptions of San Francisco's 1939 Exposition it seems as if everyone is praised but the architect. Further than to assume that one or more persons had to do with its creation, the public would appear to be unconcerned. To the average layman the identity of these men apparently has no particular significance . . . at least at the moment. But possibly the next generation will be more solicitous for the names of the architects and engineers who conceived and built this Fair of Fairs. Usually that is the case.

In the pages that follow, these names are given the prominence they deserve. To those at all familiar with the architectural profession here the thought must come, after reading the list, that they are all local men—a tribute, indeed, to the versatility and skill of our own people. It is the first time in Exposition history in the West that importation of outside talent was unsought. San Francisco skill, again, has been adequate and, in return for the welcomed opportunity, it has turned in a fine performance.

World's Fairs have emphasized many ideas in their long history, but never before has one fulfilled the goal sought more successfully than this. Romance, adventure, the perfume of distant and exotic places . . . a Fair beautiful for its architecture and rich in auxiliary elements . . . gardens, in profuseness and variety, possible only beneath California sunshine; sculpture, ranging from mediocre conventional to pseudo-primitive; color, in all its radiance; illumination, brilliant and bewildering. That is Treasure Island!



TOWER OF THE SUN

ARTHUR BROWN, JR.,
ARCHITECT

GOLDEN GATE INTER-
NATIONAL EXPOSITION,
TREASURE ISLAND

RELATIONS OF MASS, SPACE,
LINE AND COHERENCE HAVE
GOVERNED THE COMPOSITION
OF THE TOWER. THE VERTICAL
MOTIF IS INEVITABLE AS A
CONTRAST AND FOIL TO THE
ESSENTIALLY HORIZONTAL
CHARACTER OF THE BAY, THE
ISLAND AND THE INTENTION-
ALLY PARALLEL LINES OF THE
BUILDING GROUPS.

IT HAS BEEN THE AIM, IN
ARCHITECTURAL EXPRESSION,
NOT TO RESORT TO VISUAL
SHOCK OR STRANGE IDIOM,
NOR TO SEEK TO EXPRESS
IDEAS OF EITHER LITERARY
ORIGIN OR THOSE INAPPRO-
PRIATE TO THE MEDIUM. THE
SURROUNDING COURT OF
HONOR AND ITS ACCESSORIES
ARE PLANNED TO RHYTHMI-
CALLY AMPLIFY AND BECOME
AN INTEGRAL PART OF THE
TOWER DESIGN.

The Architectural Planning of the Exposition

by Arthur Brown, Jr.

THE task of crystallizing architecturally the dream of Treasure Island was assigned to the Board of Architects.* For a dream it was in the beginning. All physical limits were vague and intangible save the amazing reality of a newly created island. Our problem was first approached in a broad, abstract manner, each member of the Board feeling his way towards possible architectural groupings and guiding principles in the formation of a final definite scheme which would satisfy, as they developed, the complicated needs of the Exposition activities.

Certain limiting conditions were derived from the experience of past fairs — probable attendance — space necessary for exhibits, concessions and entertainment — financial possibilities — all highly speculative factors and difficult to appraise with reasonable precision. Structural types and building materials were also given early consideration.

Another phase vitally important to the high hope of the enterprise was the creation of a scene that would vividly interest, inspire and draw to the gates, the varied types of expected visitors. Constant reference to the budget, which limited as well as encouraged flights of the imagination, controlled all other considerations. Quite a formidable responsibility, as well as a glorious opportunity! But the Board, in spite of obvious danger, has tried to

reach a straightforward solution without too much distraction by the storms of doctrine. As tentative ideas were developed, additional limiting factors constantly appeared to expand and complete the program.

Out of these preliminary gropings came the idea of massing the main group of Palaces to the windward on the Island, in order to avoid passing through a vast area of massed cars before reaching the Fair itself, was another much discussed decision.

THE KEY PLAN

The basic general plan gradually grew out of the expanding program and resulted in the Key Plan which has since guided the placing of the various structures large and small. The Key Plan itself

was sufficiently elastic to permit many modifications to meet changing conditions, at the same time losing none of its essential characteristics.

The Key Plan assigns the compact parking space to the north end of the 400-acre island and arranges the southern rectangle in a grid-iron of avenues, giving access to the building groups. The broad principle of building units joined by a tissue of clear communications is here definitely applied.

In its simplest terms, the general plan consists



ARTHUR BROWN, JR.
Chairman of the Board of Architects, Golden Gate International Exposition

*The late G. W. Kelham, Chairman 1935-1936; Arthur Brown, Jr., Chairman 1936 to completion; Lewis P. Hobart, William G. Merchant, Timothy L. Pflueger, Ernest E. Weiher, W. P. Day, Director of Works, ex officio; E. L. Frick, Secretary.

of an arterial girdle approximately rectangular, which joins the principal structures of the Fair. This girdle passes along the north-south axis of the main buildings, turning to the east at the north court, then turning south, continues past the Federal Building, and thence west until it closes on itself near the southern end of the north-south axis of the Palaces.

The artery is tapped by three entrances, giving access from the outside world. Visitors coming by motor enter at the Court of Honor through the Elephant Gates. The Ferry brings visitors from San Francisco to the entrance at the North Court of Pacifica, and East Bay visitors join the artery at its north east corner. There is in addition a ceremonial Water Gate to the east of the Federal Building and also the Yacht Harbor off the South Garden in the Yerba Buena Basin.

MONUMENTAL AXIS

For the sake of contrast and dramatic climax a monumental axis has been created, leading east from the main entrance and Tower of the Sun, through the Court of Reflections and the Court of Flowers to the Lagoon which is flanked by the Pacific Basin Group and the State of California, and culminates in the "Colonnade of the Forty-Eight States" of the Federal Building.

Scattered throughout the gridiron are distributed points of absorbing interest, magnets that are planned to draw the attention of the crowds of visitors to all parts of the area and thus prevent the minor attractions from being isolated in unfrequented corners. These regions of more than ordinary interest are the Esplanade and the Main Courts and Buildings to the west; the Amusement Zone to the northeast; the Federal Building to the east; the State and Counties of California to the southeast; the Fine Arts and Aviation Building, the Yerba Buena Club and colorful South Garden to the south. Within the girdle of the main artery are the beautiful Courts of Reflections and Flowers, and the Lagoon with its canals, serving to unify the Pacific Basin Pavilions, Pacific House and the gay and colorful foreign participation.

The expression of the scheme is adorned, reinforced and accentuated by admirably rich and

abundant planting. Trees, shrubs and flowers are all about in amazing profusion and beauty. The plan is further developed when at night, the buildings and courts are caught in a fairy-like web of light, indescribably mysterious and poetic, varying the daylight aspect and itself integrated into an harmonious unity. The use of water in the lagoons and fountains, recalling the enveloping stretches of the Bay, serves also to affirm the unique character of the site.

MANY COMPOSITIONS CONSIDERED

This briefly is the anatomy of the general plan, and reflects the very positive architectural intention involved, based on the shape and character of the island terrain and its points of access.

Many different compositions were proposed, discussed and weighed in view of the governing limitations and requirements. For example, the idea of lining the water's edge with buildings was eliminated by the fire hazard; and objections were advanced against the more extensive use of internal canals and waterways. Both were features which I personally would have liked to have seen adopted.

In the course of adjustment of the Key Plan, the imaginative Temple of Music by Messrs. Merchant and Maybeck was reluctantly abandoned, and the Pacific House substituted as the central motive of the Pacific Basin. The function of the Theater originally planned as a part of Mr. Pflueger's Court of Pacifica, is now fulfilled by the Auditorium of the State group.

The main lines of the Key Plan were settled during the summer of 1935. The parts of the scheme to be built by the Exposition Company were outlined. The units of Palace and Court were assigned to individual members of the Board for intensive study and design. The personal taste of each member had free-play but was carefully discussed by the Board in order to coordinate the parts in mutual harmony. Finally, at the end of 1936, the architectural model was made and the component units further adjusted and clarified. The architectural designs were brought to the final stage early in 1937 and the structural and contract drawings and specifications were then prepared in the Exposition office.

THE MEN WHO MADE TREASURE ISLAND

THE Board of Architects worked in close consultation with W P. Day, Director of Works, in whose department the component parts were developed into structural and contract drawings, and the specifications prepared. The Works Department likewise estimated the costs, adjusted the budget, and finally let the contracts and carried on the building operations.

The Triumphal Arch and adjoining Courts were allocated to Mr. Hobart; Messrs. Bakewell & Weihe designed the western facade and entrance motifs; Mr. Pflueger, the court and fountain of Pacifica; Mr. Merchant, Pacific House; Messrs. Maybeck & Merchant, the lagoon and temples of the East; Mr. Kelham, the South Garden and Courts of the Moon and Seven Seas; Messrs. Kelham and Day, the permanent Hangars and Administration Building; and Arthur Brown, Jr., was assigned the Court of Honor and Tower of the Sun.

Each architect of the Board personally designed his allotted building or court, with the aid of a chief assistant, who followed the development of the design through to the final stage, in the Exposition office. The key men were: for Mr. Hobart, L. B. Miller; for Mr. Pflueger, Fred Chapman; for Mr. Kelham, Wm. G. Pigeon, A. L. Wilson and Joseph Clark. Mr. Weihe and Mr. Bakewell were assisted by Gerald Craner; Mr. Merchant, who is associated with Bernard Maybeck, was assisted by William Evans; and Mr. Brown was assisted by E. L. Frick, (later Chief of Architecture) and Lawrence Kruse.

Collaborating with the Board in the Works Department, E. L. Frick has served as Chief of the Division of Architecture, and Secretary and Liaison Officer of the Board of Architects, and Alexander Wagstaff has been the Chief Draftsman in charge of the Architectural Drafting Staff. Mr. Frick, as Chief of the Architec-

(Turn to Page 72)



July 5, 1934, analyzed six possible sites, gave particular consideration to two and unequivocally recommended Yerba Buena Shoals as the location offering the greatest advantages. The general viewpoint was indicated by the following paragraph from the introduction to the report: "The selection of the most suitable site for an Exposition of this character must be controlled by those elements which offer the greatest probability of financial success, consistent with the achievement of the objects of the Exposition. For a given site, such elements are the cost of construction and operation thereof, accessibility, weather conditions, salvage possibilities or adaptability to permanent improvement, and its ability to create an advertising value purely by its setting or relationship to its surroundings. These offer a measuring stick as to its desirability."

In May, 1934, the Bridge Celebration Foundation Committee formed a corporation with Leland W. Cutler as president and Atholl McBean as chairman of the board of directors. This corporation proceeded to act on the location committee report. The proposed Yerba Buena Shoals site was ceded by the State of California to the City of San Francisco for development and use as a public airport, and the city authorized use of the site temporarily for an Exposition, stipulating that the property be returned to the city when the Exposition was over. Choice of the site was ratified by the voters at an election in 1935. The final move in the preliminary stage was the selection of the writer as the director of works in May, 1935, and the authorization for him to prepare plans and specifications for reclaiming the underwater site. These plans had to be prepared in his private office, as there was no engineering organization for the Exposition at that time.

The necessity for raising funds presented an interesting problem. It was early recognized that, because of the prospective airport features, assistance might be obtained through the PWA and the WPA. An application for Federal funds required that the sponsor be a political entity, and that a project be detailed as to all materials required as well as the number of men to be employed in each craft, the

number of hours of employment of each, the total cost per man hour, etc.

To meet this situation the director of works prepared eight applications covering (1) reclamation and sea wall, (2) water supply, (3) roadways and bridges, (4) horticulture, (5) pavements, (6) ferry slips, (7) airport and other buildings, and (8) architectural and engineering design. As a result of these applications, in September, 1935, the WPA granted funds in the amount of \$4,349,992. The sponsor's contribution was \$1,087,499, making a total of \$5,437,491. (San Francisco was the sponsor in name: the contribution was actually furnished by the Exposition company.) In addition, the PWA granted \$1,894,274 as against a contribution of \$2,315,335 by the company in behalf of the city. Thus the Federal government advanced \$6,244,266. This sum was later increased by supplemental applications to a grand total of \$7,262,399.

An additional sum of \$7,500,000 was raised directly by the Exposition company through pledges from business and commercial interests in the Bay area. These pledges, payable in installments, are against non-interest revenue certificates. Whatever the ultimate surplus may be has been committed in settlement of these obligations pro rata. The major part of the remainder of the income is figured against admissions, utilities, exhibit space and concessions.

MEETING FEDERAL REQUIREMENTS

Shortly after the PWA grant was allowed, and before an engineering organization had been attempted, the Exposition company was notified that, to obtain the promised funds, construction would have to begin by December 15, 1935. The Exposition had no stated program at that time, of course, but met the requirement by starting construction of an administration building on the mainland in San Francisco, and shortly thereafter, by beginning the construction of ferry slips at the Exposition site. At this time, there was no land near the slips, and justification for ferry slip construction was not apparent. However, this procedure was the only way to meet Federal requirements that the work be prosecuted continuously, in-

(Turn to Page 49)

SAN FRANCISCO BAY

LEGEND

- 1 PALACE OF THE ARTS, 131 1/2' x 131 1/2'
- 2 HOTEL DE WASHINGTON
- 3 HOTEL DE CALIFORNIA BUILDING
- 4 EAST WING, OTTOMAN COLONNADE
- 5 WEST WING, OTTOMAN COLONNADE
- 6 PALACE OF THE MINES AND MINERALS BUILDING
- 7 PALACE OF THE COINTEGRATED INDUSTRIES BUILDING
- 8 HOTEL DE WASHINGTON
- 9 HOTEL DE CALIFORNIA
- 10 HOTEL DE WASHINGTON
- 11 HOTEL DE CALIFORNIA
- 12 HOTEL DE WASHINGTON
- 13 HOTEL DE CALIFORNIA
- 14 HOTEL DE WASHINGTON
- 15 HOTEL DE CALIFORNIA
- 16 HOTEL DE WASHINGTON
- 17 HOTEL DE CALIFORNIA
- 18 HOTEL DE WASHINGTON
- 19 HOTEL DE CALIFORNIA
- 20 HOTEL DE WASHINGTON
- 21 HOTEL DE CALIFORNIA
- 22 HOTEL DE WASHINGTON
- 23 HOTEL DE CALIFORNIA
- 24 HOTEL DE WASHINGTON
- 25 HOTEL DE CALIFORNIA
- 26 HOTEL DE WASHINGTON
- 27 HOTEL DE CALIFORNIA
- 28 HOTEL DE WASHINGTON
- 29 HOTEL DE CALIFORNIA
- 30 HOTEL DE WASHINGTON
- 31 HOTEL DE CALIFORNIA
- 32 HOTEL DE WASHINGTON
- 33 HOTEL DE CALIFORNIA
- 34 HOTEL DE WASHINGTON
- 35 HOTEL DE CALIFORNIA
- 36 HOTEL DE WASHINGTON
- 37 HOTEL DE CALIFORNIA
- 38 HOTEL DE WASHINGTON
- 39 HOTEL DE CALIFORNIA
- 40 HOTEL DE WASHINGTON
- 41 HOTEL DE CALIFORNIA
- 42 HOTEL DE WASHINGTON
- 43 HOTEL DE CALIFORNIA
- 44 HOTEL DE WASHINGTON
- 45 HOTEL DE CALIFORNIA
- 46 HOTEL DE WASHINGTON
- 47 HOTEL DE CALIFORNIA
- 48 HOTEL DE WASHINGTON
- 49 HOTEL DE CALIFORNIA
- 50 HOTEL DE WASHINGTON
- 51 HOTEL DE CALIFORNIA
- 52 HOTEL DE WASHINGTON
- 53 HOTEL DE CALIFORNIA
- 54 HOTEL DE WASHINGTON
- 55 HOTEL DE CALIFORNIA
- 56 HOTEL DE WASHINGTON
- 57 HOTEL DE CALIFORNIA
- 58 HOTEL DE WASHINGTON
- 59 HOTEL DE CALIFORNIA
- 60 HOTEL DE WASHINGTON
- 61 HOTEL DE CALIFORNIA
- 62 HOTEL DE WASHINGTON
- 63 HOTEL DE CALIFORNIA
- 64 HOTEL DE WASHINGTON
- 65 HOTEL DE CALIFORNIA
- 66 HOTEL DE WASHINGTON
- 67 HOTEL DE CALIFORNIA
- 68 HOTEL DE WASHINGTON
- 69 HOTEL DE CALIFORNIA
- 70 HOTEL DE WASHINGTON
- 71 HOTEL DE CALIFORNIA
- 72 HOTEL DE WASHINGTON
- 73 HOTEL DE CALIFORNIA
- 74 HOTEL DE WASHINGTON
- 75 HOTEL DE CALIFORNIA
- 76 HOTEL DE WASHINGTON
- 77 HOTEL DE CALIFORNIA
- 78 HOTEL DE WASHINGTON
- 79 HOTEL DE CALIFORNIA
- 80 HOTEL DE WASHINGTON
- 81 HOTEL DE CALIFORNIA
- 82 HOTEL DE WASHINGTON
- 83 HOTEL DE CALIFORNIA
- 84 HOTEL DE WASHINGTON
- 85 HOTEL DE CALIFORNIA
- 86 HOTEL DE WASHINGTON
- 87 HOTEL DE CALIFORNIA
- 88 HOTEL DE WASHINGTON
- 89 HOTEL DE CALIFORNIA
- 90 HOTEL DE WASHINGTON
- 91 HOTEL DE CALIFORNIA
- 92 HOTEL DE WASHINGTON
- 93 HOTEL DE CALIFORNIA
- 94 HOTEL DE WASHINGTON
- 95 HOTEL DE CALIFORNIA
- 96 HOTEL DE WASHINGTON
- 97 HOTEL DE CALIFORNIA
- 98 HOTEL DE WASHINGTON
- 99 HOTEL DE CALIFORNIA
- 100 HOTEL DE WASHINGTON

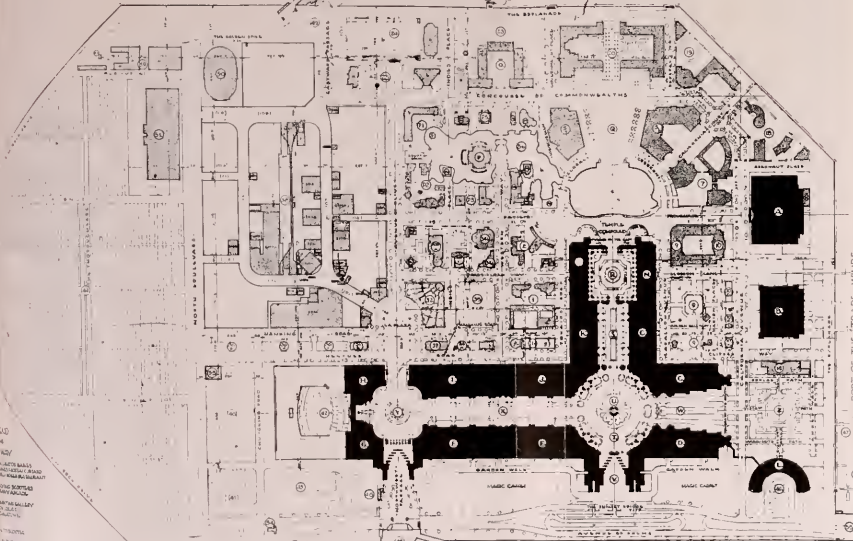

- 101 GIFT STAND
- 102 HOTEL DE WASHINGTON
- 103 HOTEL DE CALIFORNIA
- 104 HOTEL DE WASHINGTON
- 105 HOTEL DE CALIFORNIA
- 106 HOTEL DE WASHINGTON
- 107 HOTEL DE CALIFORNIA
- 108 HOTEL DE WASHINGTON
- 109 HOTEL DE CALIFORNIA
- 110 HOTEL DE WASHINGTON
- 111 HOTEL DE CALIFORNIA
- 112 HOTEL DE WASHINGTON
- 113 HOTEL DE CALIFORNIA
- 114 HOTEL DE WASHINGTON
- 115 HOTEL DE CALIFORNIA
- 116 HOTEL DE WASHINGTON
- 117 HOTEL DE CALIFORNIA
- 118 HOTEL DE WASHINGTON
- 119 HOTEL DE CALIFORNIA
- 120 HOTEL DE WASHINGTON
- 121 HOTEL DE CALIFORNIA
- 122 HOTEL DE WASHINGTON
- 123 HOTEL DE CALIFORNIA
- 124 HOTEL DE WASHINGTON
- 125 HOTEL DE CALIFORNIA
- 126 HOTEL DE WASHINGTON
- 127 HOTEL DE CALIFORNIA
- 128 HOTEL DE WASHINGTON
- 129 HOTEL DE CALIFORNIA
- 130 HOTEL DE WASHINGTON
- 131 HOTEL DE CALIFORNIA
- 132 HOTEL DE WASHINGTON
- 133 HOTEL DE CALIFORNIA
- 134 HOTEL DE WASHINGTON
- 135 HOTEL DE CALIFORNIA
- 136 HOTEL DE WASHINGTON
- 137 HOTEL DE CALIFORNIA
- 138 HOTEL DE WASHINGTON
- 139 HOTEL DE CALIFORNIA
- 140 HOTEL DE WASHINGTON
- 141 HOTEL DE CALIFORNIA
- 142 HOTEL DE WASHINGTON
- 143 HOTEL DE CALIFORNIA
- 144 HOTEL DE WASHINGTON
- 145 HOTEL DE CALIFORNIA
- 146 HOTEL DE WASHINGTON
- 147 HOTEL DE CALIFORNIA
- 148 HOTEL DE WASHINGTON
- 149 HOTEL DE CALIFORNIA
- 150 HOTEL DE WASHINGTON

SAN FRANCISCO BAY

GOLDEN GATE INTERNATIONAL EXPOSITION

1939 A PAGEANT OF THE PACIFIC 1939



VERDA BUENA ISLAND





DETAIL OF CLOISTER, COURT OF FLOWERS, TREASURE ISLAND
LEWIS P. HOBART, ARCHITECT

Romance

The Court of Reflections and the Court of Flowers

by Lewis P. Hobart, Architect

THE Court of Reflections is a passageway connecting the Court of the Sun and the Court of Flowers. This was treated simply, with great walls banked with shrubbery and terraced levels to give a variety of point of view to the reflections; also giving on the East-West axis a full reflection of the Tower, revealing its entire height and in the reverse direction, showing the reflections of the arch.

The Court of Flowers, which has a central fountain, with the Girl of the Rainbow, and the four minor fountains in the corners, I designed as a resting place where one may linger beneath the arches, listen to the band music and enjoy the view.

The Triumphal Arch, while being a feature in both courts, was partially designed for a wind-break and to give intimacy to the Court of Flowers.

Both these courts have a slight reminiscence of the Spanish and Mexican motifs, worked over entirely so that the old is hardly recognizable.

I would like to express my appreciation for all the assistance I received—in the drafting room, with the planting, mural decorations, and the color—which was so generously given me.

The greatest endeavor of all was to have charm in the two courts, an accomplishment that I hope has been achieved.



COURT OF FLOWERS WHERE ONE MAY REST AND ENJOY THE
LOVELY SURROUNDINGS. BAND CONCERTS NEARBY WILL ADD
TO THE PLEASURE OF THE VISITOR

LEWIS P. HOBART, ARCHITECT



Statuary by Olaf Malmquist

A MORE INTIMATE VIEW OF THE COURT OF FLOWERS SHOWING FOUNTAIN AND REFLECTING POOL IN THE FOREGROUND. AT THE LEFT, THROUGH THE ARCH OF TRIUMPH, IS REVEALED THE BEAUTIFUL COURT OF REFLECTIONS

LEWIS P. HOBART, ARCHITECT



DETAIL OF ELEPHANT TOWERS, MAIN PORTALS OF
GOLDEN GATE EXPOSITION, TREASURE ISLAND
BAKEWELL AND WEIHE, ARCHITECTS

Wind Breaks

The Portals of the Pacific

by Ernest E. Weihe, A. I. A.

THE broad factors to be considered in the planning of the western facades were the protection against Public Enemy No. 1—the summer winds—the creation of an impression of welcome to the visiting public which would arrive from the same general direction as the wind, and an architectural effect legible both by day and by night from San Francisco.

The solution is an attempt to form a high barrier of walls which would leave the interior courts sheltered and pleasant. The entrances are marked by welcoming arms extended forward from the main barriers. A system of wind baffles is employed at the entrances so that it will be unnecessary to go



The Exposition is in effect a walled city, the western facades forming a barrier against the summer winds. The arriving visitor is embraced by the outstretched arms of entrance motifs. Variations of light and shade give colorful effect.

through swinging doors or any closed vestibule.

The architectural treatment adopted was simple and dramatic; dramatic because the elements employed were of necessity large and also because the first impression should establish an exposition or show character.

The elephant forms were used sculpturally because of their universal association with pageantry and because they afford a broad use of planes and masses at a scale harmonious with facades a half mile long. An attempt has been made to produce an active, colorful effect by the use of the normal variations of light and shade. All surface decoration was avoided, a pattern of design on the walls being achieved by the varying shadows cast by the simple masonry forms and by the palm trees and other verdure.

The effect at night is one of brilliantly-colored foreground structures, such as foot bridges, cross-overs, booths, flag poles and light

standards against a simple tonal lighting of the main walls. Occasionally colored light accents are used. The trees also form an important part of the night effect. From distant points the impression is that of a phantom city floating on the water of San Francisco Bay.



THE SPIRIT OF ORIENTAL PAGEANTRY AT TREASURE ISLAND. AT THE LEFT STANDS THE 400-FOOT TOWER OF THE SUN BY ARTHUR BROWN, JR., WHILE IN THE FOREGROUND ARE THE TWO MASSIVE ELEPHANT TOWERS, FLANKING THE MAIN ENTRANCE, FACING WEST, AND KNOWN AS THE PORTALS OF THE PACIFIC, DESIGNED BY BAKEWELL AND WEIHE, ARCHITECTS



IMPRESSIVE DETAIL OF ADMINISTRATION BUILDING, TREASURE ISLAND
GEO. W. KELHAM AND WILL P. DAY, ARCHITECTS



GRACEFUL PALM TREES LINE THE HIGHWAY ON THE WESTERN SIDE OF TREASURE ISLAND. THROUGH THE FRONDS MAY BE SEEN A PORTION OF THE ADMINISTRATION BUILDING DESIGNED BY THE LATE GEO. W. KELHAM AND WILL P. DAY.

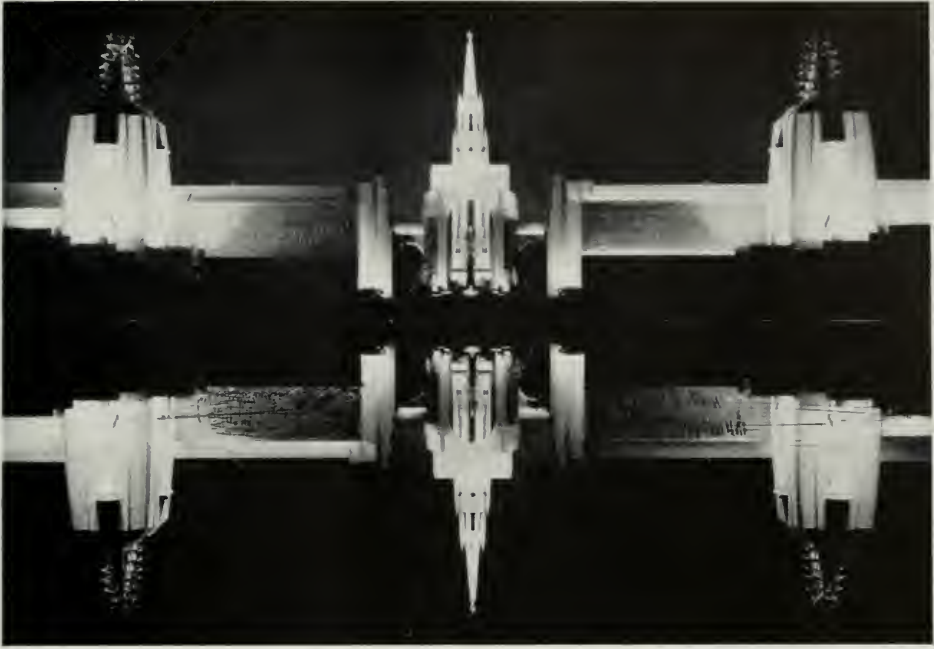

REFLECTED NIGHT VIEW, TEMPLES OF THE EAST
William G. Merchant and Bernard R. Maybeck,
Architects

Temples of the East

by William Gladstone Merchant, Architect

THE "Temples of the East" are the result of a composite blending of the masses and details of the Occident with those of the Orient. It is an attempt at recalling the purposes of the Exposition, "A Pageant of the Pacific." The Temples' mass is particularly influenced by the Orient. Its crowning motif was inspired by the processional umbrellas of Siam.

The great steps are similar to those seen along the Ganges; it was originally intended to have the lagoon waters at their base.

The great metal plaques called "Darkness and Light and Life," as well as other details, recall more the Occident than the Orient.

These Temples and Lagoon represent only a portion of a larger original scheme, which included a great Temple of Music with adjoining terraces which was revised to suit a later arrangement.



Photo by Roberts and Roberts

TEMPLE COMPOUND AND TOWER OF THE EAST, TREASURE ISLAND
WILLIAM G. MERCHANT AND BERNARD R. MAYBECK, ARCHITECTS



Photo by Roberts and Roberts

PACIFIC HOUSE ON RIGHT, THE JOHORE DEWAN, OR COUNCIL
HOUSE, CENTER
WILLIAM GLADSTONE MERCHANT, ARCHITECT OF PACIFIC HOUSE



PACIFICA, AT THE END OF THE COURT OF THE SEVEN SEAS.
NOTE SHIP'S MAST AND CROW'S NEST LIGHTING STANDARDS

TIMOTHY L. PFLUEGER, ARCHITECT



CALIFORNIA COLONNADE WITH THE CALIFORNIA HOSPITALITY BUILDING
AT THE LEFT AND SAN FRANCISCO BUILDING ON THE RIGHT

TIMOTHY L. PFLUEGER, ARCHITECT

(For detailed description turn to Page 51)



CALIFORNIA STATE HOST BUILDING, TREASURE ISLAND
TIMOTHY L. PFLUEGER, ARCHITECT



Prominent buildings of the California State Commission group shown above may be readily identified as follows: (1) Livestock Barns; (2) Coliseum; (3) Recreation Building and Field; (4) Southern Counties Building; (5) Auditorium; (6) San Francisco Building; (7) California State Building; (8) Shasta-Cascade Building; (9) Hall of Flowers; (10) Mission Trails Building; (11) Alameda-Contra Costa Building; (12) Alta California Building; (13) Redwood Empire Building; (14) Sacramento Valley-Tahoe Region Building; (15) San Joaquin Valley Building.

Color and Light

Treasure Island Brilliant Beyond Words

by *J. E. Stanton, Chief of Color*

WHEN classifying the architecture of the Golden Gate International Exposition on Treasure Island, a gem-like setting that centers the Bay of San Francisco, it may be said at the outset that the great masses and general concepts follow the eminent classics with the power and directness of Rome. Though definitely modern in adjusted treatment, with a rightful mingling of the Oriental, Cambodian and Mayan—this being a Pageant of the Pacific—in the lesser masses and details there exists a basic beauty, refinement, richness interwoven with a sure touch of yesterday.

To be immediately acceptable to the discriminating, and to offer a color scheme that will excite the admiration of an acknowledged esthetic community—such is the hoped for attainment. Further, the color has repose, dignity and a beauty of balance in masses and contrasts—color as an aid to the glorification of architecture and sculpture. Thus, under all conditions of light, both by day and by night, the Exposition is not merely the embodiment of great color for it dramatizes a beautifully colored architecture conceived in the same root of thought.

The standard palette of Exposition colors includes nineteen in all, plus the use of gold. Seven are body colors, all warm, light intensities, in perfect harmony with each other. Eight additional colors serve for the embellishment of ornamental work and bases. Four others, including gold, are for doors, trims, and other special purposes. Following is the complete list: Exposition ivory, Old Mission fawn, pagoda yellow, Pebble Beach coral, Santa Barbara

taupe, California ecru, evening star blue, Polynesian brown, Sun of Dawn yellow, Hawaiian emerald green, Santa Clara apricot, imperial dragon red, Death Valley mauve, Pacific blue, Ming jade green (light), Ming Jade green (dark), Southern Cross blue, Del Monte blue, China Clipper blue, Treasure Island gold.

All palace buildings and outside exhibit structures follow the color scheme of the official palette. All inside exhibits and concessions in the various palaces also follow the adopted palette, except where nationally known trade marks call for their own colors, which have been allowed but they have to harmonize with the official scheme. No pure colors are permitted; all are necessarily reduced to half tones or values harmonizing with the official palette.

Exposition walls are plastered in a warm, light, ivory plaster with a luminous cast of gold pink—a plaster texture achieved by pressing Zonolite into the surface, being determined upon after samples had been exhaustively studied for two years. The material is produced by heating mica to such high degree that it becomes flaky and the leaves separate to become a lasting, luminous gold in color, the surface being broken into myriads of small holes as each little facet glitters with a luminous quality. This treatment is given the main walls of Exposition palaces, Tower of the Sun, Administration Building, the Palaces of Fine Arts and of Aviation, and ferry terminals.

The great entrances to the west—Portals of the Pacific—recall Cambodian-Mayan architecture: their effect is greatly heightened in crimson and gold, emphasizing Exposition char-

acter and the importance of entrance and exit. The two towers facing east—Pagodas of Rangoon and Mandalay—which definitely recall Indian or Oriental architecture, face the Federal and California buildings: these are developed as antiques, with beaten gold metals and rich crimson colors, the pagodas rising above semi-circular tiers of seats facing the Lagoon with moss green slopes. The whole scene immediately transports one on a magic carpet to the mystic land of dreams.

The Pacific Basin architecturally portrays those colorful countries that border the vast Pacific, each building with its true-to-form characteristics, the whole tied in to form a perfect ensemble with the waters of the Lagoon and native horticulture.

Entering the Court of the Moon from the South Gardens on the great north-south axis, the Court is revealing in Evening Star blue, supplemented with appropriate floral tones: at night, it recalls the Court of the Caliphs of Arabian Nights fame. Thence into the great Court of Honor, bringing to mind the plaza of San Marco. Centering this court is the gloriously proportioned Tower of the Sun, 400 feet high. At night, the Sun Tower is bathed at its base in pale amber that becomes a brilliant white light at the spire: the figure of the Phoenix that crowns the spire fittingly rises from a bright red illumination at its base.

Northward, through the "never ending"

Court of the Seven Seas, comes a revelation of one thousand feet of massive, flanking pylons capped with ships prows, thundering down in perspective. The Seven Seas Court is heightened in color, the base and embellishments being emphasized in Pompeiian colors of buffs and reds; at night it appears in a light, luminous apricot, the intensity dropping with the architectural set-backs. In the sixteen great niches, the night effects are new and startling. Black light, seeming to spring from nowhere, illumines hitherto unused phosphorescent paint of many hues which does not commit itself as color in the daylight.

Thence into the majestic proportions of the Court of the Pacific with its awesome 80-foot figure of Pacifica that graciously blends the cultures of Pacific lands. At night, Pacific Court is gently illuminated by 65-foot lanterns, four feet in diameter, giving off a glowing apricot color, imparting a note of warmth and joy. Returning to the Tower of the Sun, the view first embraces the Court of Reflections, through the entire length of which the reflecting basin throws back the images of the Arch of Triumph, the Fountain of Abundance, the massive Federal Building; here the color is a Pebble Beach coral, while at night it glows with a deep, warm pink.

Color and the part it plays at the World's Fair of the West is vast, far-reaching: it virtually defies description except to provoke a desire actually to behold it in all its moods.

MORE FAIR BUILDINGS TO BE SHOWN LATER

Because they were not in proper shape for photographing at the time of going to press, and also because of limited space, the following buildings will be shown in later issues of *Architect and Engineer*: The colorful Foreign pavilions, Western States Building and other State pavilions; a number of the special exhibit buildings and some of the more interesting features of the Gateway. More detailed views of the main courts also will be shown, together with a number of the privately owned structures. Due credit will be given the architects of these structures.



SCULPTURE BY ROBERT HOWARD IN PAVILION OF THE ELEVEN WESTERN STATES

Sculpture

THE architectural features of the Fair buildings are adorned and amplified by the use of sculpture and mural painting.

To this end, dozens of the outstanding sculptors, muralists and artisans were employed. From such colossals as the seventy-foot figure of Pacifica to the tiny niche figurines, bits of plastic art and detailed staff work, the story of the progress and cultural unity of the Pacific shores is told. In these various media the mysticism of the East and the vision of the West has been impressively expressed.

Entrance to the Exposition proper will be between two mighty gates, the Portals of the Pacific and the ferry passenger entrance. The main gates, designed by Ernest E. Weihe, rise

step by step to crowning turrets 120 feet high in the form of elephant heads and howdahs, age-old symbols of pageants and pleasures. Those surmounting figures as well as the ones on the lesser gates, were created by Donald Macky.

In the Court of Honor, O. C. Malmquist has done a series of reliefs depicting the various winds and the signs of the zodiac. Surmounting the lofty spire of the Tower of the Sun is a huge phoenix by Malmquist and executed by John Foster, symbolizing the rise of San Francisco from the ashes of the disastrous fire of 1906. For the arches in the tower, William G. Huff executed some eight fine pieces of statuary.

(Turn to Page 68)



MacDonald & Kahn, Builders

PAGODA, TOPPED BY TRADITIONAL "GOLDEN BELLS," IN THE CHINESE VILLAGE AT THE GOLDEN GATE INTERNATIONAL EXPOSITION. A TERRACED RESTAURANT IS AT THE LEFT

MARK DANIELS, ARCHITECT

Landscaping

Beautification of Grounds and Gardens

by *Mark Daniels, A. I. A.*

THE landscape treatment of an exposition presents a radically different problem from that developed by the city park or the private estate. Certain features that are not called for in the latter are essential and prerequisite in exposition work, and the reverse is equally true. In the work of developing parks and private estates, the esthetic consideration is ever foremost and is influenced against the best taste only by the item of cost, while in exposition work it must be borne in mind that the planting should carry educational value as well as ornamental. Certain varieties of silva and flora might not be used in private estate work where they were not at the height of propriety in association with the architecture, and yet they might be quite justified in decorating grounds and garden areas at an exposition, for their educational value alone.

The prime consideration of landscape treatment around residences and in private estates is the ornamentation and beautification of a particular type or example of architecture. In a city park, the plan may take a more widely varied style but there is little other than climatic and soil conditions to prevent adopting what is desired and carrying it out with unity and finish. In an exposition, with the tremendous variety of architecture that is often encountered, it is impossible to carry along throughout the entire scheme a certain motif, or trend of design, without encountering discrepancies and anachronisms. In other words, if one finds a Swiss chalet within thirty feet of a Chinese pagoda, and the latter only fifty feet from a Belgian legation building, and so on, it is impossible to carry a single line of landscape treatment across the front of each which will be in perfect harmony with all of the others. One might say, of course, that the

thing to do is just plant a long line of green foliage; yet if this is done the value of education as to varieties of plants must be almost entirely ignored.

Again there is the problem of obtaining immediate effect. In expositions the planting must be done within a very limited time, but when finished, it is desired that that planting shall look as if it had been there for a decade. This means there must be a generous use of full grown trees, large boxed material weighing sometimes as much as ten tons, and these planted so that the effect is that of years. Sometimes the demands for these effects are almost impossible of satisfaction. They come to the landscape architect from those who have designed the buildings with the statement "Now, you must plant this up within the next thirty



days and make its beauty perfected." It is like the big, burly man who finds himself in quiet company and turns with a roar to the timid young man at his elbow and says "Now laugh, damn you, laugh." This is a hard job to carry out, but Julius Girod, under the direction of John McLaren has come as close to it as anyone I have known.

Strange Creatures, We Americans

We humans are a race of strangely inconsistent creatures. We fight to the death against another man's religion and capitulate to crime in our own community; we cry at weddings and sing at funerals; we strip our streets of trees and go to Paris to sit under the branches of the flowering chestnuts that overspread the sidewalk cafes; I have heard a number of people criticize the planting of the avenues at the Exposition on the grounds that the trees there are not indigenous to California or that they are not commonly used in the immediate vicinity of San Francisco Bay. Many times I have heard objections voiced against the use of olive trees along the boulevards at the Exposition on the ground that they are not used for avenue planting nor are they used to any extent in the immediate vicinity of San Francisco.

These criticisms seem particularly groundless in the present circumstance. It is true that olive trees are not used around the bay to any great extent but it is also true that expositions are not a permanent development. It is every bit as consistent to plant the avenues of an exposition with trees that are not indigenous or common to the immediate locality as it is to build an exposition at all. Further than this, an exposition partakes of the arts and treatments of all parts of the world, or is supposed to, and one is therefore fully justified to employ exotic foliage to bring out the effect of as many landscape treatments throughout the world as can be developed in the area in which the work is done. If this idea of extreme consistency is predicated upon the thought that nothing should be used that is not indigenous to the district in which it is employed, no women should wear orchids in their corsages except the women of India and Central America.

The planting on the west exposure was dictated largely by the climatic conditions on that side of the palaces. The main avenue of Canary Island date palms is well conceived to withstand the salt spray and the heavy winds, as also are the *Washingtonias* planted closer to the buildings. In the various courts, the protection of the high walls enabled the landscape architects who were engaged upon the preliminary plans for the landscape treatment to exercise a much freer hand. Here trees as high as forty feet could be planted in the eight and ten-foot boxes in which they were shipped and could be trusted to need no guying or wiring against the winds which were broken or entirely shut out by the walls of the palaces on either side of the courts. Here Mr. Julius Girod, who is handling all of the planting for the Exposition Company and is executing the plans of the four landscape architects who were originally employed to lay out a scheme for the various courts, will display his great collections of daffodils, tuberous begonias and flower-filled urns employing varieties of blossoming plants that will run into the hundreds of thousands.

In these courts Mr. Girod will employ not less than one thousand varieties including over four thousand trees and forty thousand shrubs. Some of these trees are all but priceless; for example, the great Irish yews that are in the courts running north and south. Full grown and fruiting orange trees will encircle the tower in the Court of the Sun. As a possible sop to those who are so insistent on the use of the indigenous material, great masses of Monterey pines and Monterey cypress line the exterior walls of the palaces to the east.

Four Landscape Architects

At the beginning of the studies for landscape treatment for the various courts, the architectural commission, then headed by the late George Kelham, decided that each member should be allowed to choose his own landscape architect. Those chosen were Thomas Church, Butler Sturtevant, Miss Bella Worn and myself. General plans for each court were then prepared and turned over to Mr. Julius Girod

(Turn to Page 48)

Engineering Design

Structural Features of the Exposition

by John E. Gould, C. E.

DURING the preparation of Structural Engineering Designs for the Golden Gate International Exposition, problems as to structural safety, utility, economy and architectural appearance were numerous and varied.

The permanent structures to be used later for airport purposes (an Administration Building and two hangars) were built of reinforced concrete and structural steel. All others, with the exception of the Tower of the Sun*, were constructed of timber employing about 27,000,000 ft. b.m. of Douglas fir lumber, (exclusive of wharfs).

Of the many groups or types of temporary structures, the Exhibit Palaces of an area of about 1,000,000 sq. ft. required the most consideration because the type of structural framing determined in a large measure the successful use of space for exhibit or functional purposes.

The framing layout had to be such that exhibits of any architectural design and weight to be built at a later date could be accommo-

dated with but minor structural alterations to existing buildings.

These desirable conditions were met by the use of 3-hinged arches varying in span of 120' to 200' and spaced 30' to 41' apart. Because exterior set back walls were made, for architectural reasons, 65' to 85' high, the arch type of roof support was of additional advantage.

The cost of this type of framing amounted to \$1.56 per sq. ft. of usable floor area including pile foundations, wood studs for walls, arches, purlin trusses and rafters, wood sheathing for roofs, together with roofing, wood floors, wall sheathing of Byrkit board, sheet metal roof leaders and minor painting.

The possibility of mass subsidence caused by consolidation of the fill itself

and by the pressing of water from existing material beneath the fill, also suggested the use of statically determinate, flexible and long open span types of framing.

For large exhibit structures or where architectural features justified, piles varying in length from 65' to 90' long were used. With the excep-



Detail of Tower Framework, Looking Up.

*For a more detailed description of the structural features, see THE ARCHITECT AND ENGINEER issue of April, 1938.

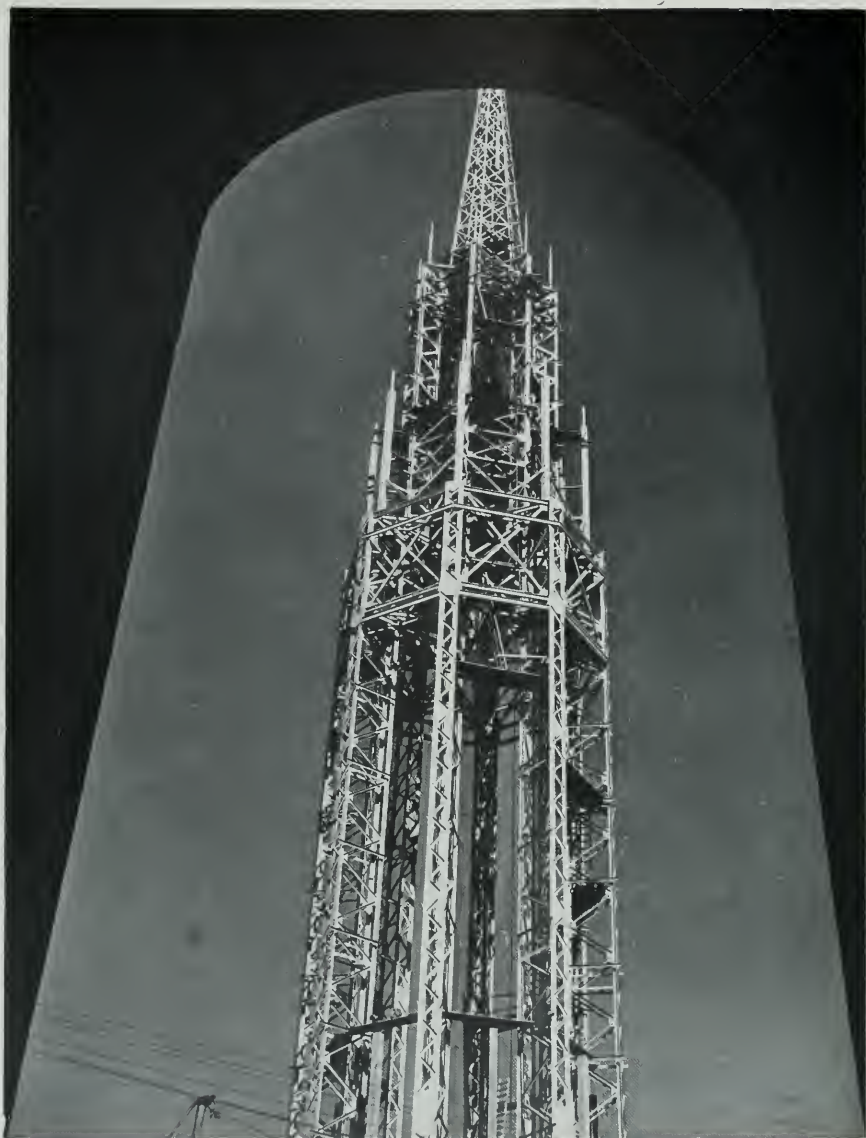

Structural steel fabricated and erected by Judson Pacific Company

**STEEL FRAMING OF CENTRAL THEME TOWER, GOLDEN GATE
INTERNATIONAL EXPOSITION, TREASURE ISLAND**

ARTHUR BROWN, JR., ARCHITECT

JOHN E. GOULD, STRUCTURAL ENGINEER



THREE-HINGED TIMBER ARCHES OF 200 FOOT SPAN, PREFABRICATED ROOF AND WALL PANELS, PALACE OF ELECTRICITY, GOLDEN GATE INTERNATIONAL EXPOSITION, TREASURE ISLAND

tion of the East Hangar Building, where levelling of certain individual piers was made for anticipated subsidence, the behavior of foundations and buildings has been most gratifying, considering the magnitude and intricacies of the subsoil problems involved. Many of the lower or simpler type of structures are supported directly on spread footings, using a soil pressure of 1500-3000 lbs per square foot.

In the design of timber structures several types of timber joints were used. Of these the more important were:

A. Rod-and block type, commonly known as the Howe type, used in large span arches and trusses.

B. Strap-and-pin design, in which timber members are used for reversible tensile and compressive stresses; the joint detail consisting of steel straps connecting to a common pin bolt. The straps are fastened to timbers by

flush type shear plates and bolts. This type of joint was used in high tower structures and in certain arches and trusses. In some instances, steel gussets were used in lieu of the strap-and-pin-bolt detail.

C. Modern ring connectors, connecting timbers by means of split metal rings. This type of joint was used in purlin trusses, braces, towers, and in general wherever the connecting loads ranged from 15 to 60 kips.

The new strap-and-pin construction resulted in a more pleasing appearance of the structures than did the older rod-and-block type. In the design of the main timber arches of the exhibit palaces surrounding the North Square Court, use was also made of a reinforced concrete block poured in between steel gusset plates in one of the major timber joints where five members were interconnected. All members are subject to reversible stresses varying from a

maximum of 180 kips compression to 25 kips tension.

Structural designs were prepared in such a manner that prefabrication of large units on the ground was possible. This feature contributed to economy, speed of erection and safety of construction. This possibility was recognized by the contractors, who erected wall panels, consisting of studs and Byrkit sheathing in units 22' x 40'. Roof rafters and sheathing of similar sizes were prefabricated and erected in a similar manner. Timber arches of 200' span were fabricated on the ground and raised bodily to final position, the entire setting operation for each arch requiring only about thirty minutes.

Because a successful completion of a large undertaking like a World's Fair depends upon an intimate cooperation of all professional groups engaged, a particular effort was made to harmonize architecture with structural engineering functions. As one of the many examples, the design of the Hall of Western States may be cited. Here a building generally 45' high and of U-shape plan was built for a total cost of \$2.66 per sq. ft. of floor area. In principle, all architectural features were employed structurally and vice versa, using diagonally sheathed roofs supported by 36' span, 3" x 16" joists, spaced 4'-0" apart and plywood sheathed walls for bracing purposes. In the 70'-wide auditorium, 3-hinged arches, built box shaped, with two layers of double diagonally sheathed webs and nailed on chords, were employed. Their pleasing shape and logical structural form fit particularly well the western atmosphere of the building.

LANDSCAPING THE FAIR

(Concluded from Page 44)

for execution, and further interpretation in cooperation with the architects of the various courts. These plans called for successions of blooms and combinations of colors such as calendulas, golden violas, brown pansies, yellow tulips, blue lobelia, sweet alyssum, blue agapanthus, lantana, and celosia crestata in mixture, to be followed in the fall by dwarf chrysanthemums and white begonias. But to go

into detail in describing the work that is being done and the group selection would occupy half of this magazine rather than a few pages.

To the east of the major groups of palaces and to the east and south of the lagoon lies the area that is being developed by the State of California through its California Commission for the Golden Gate International Exposition. Here there is a great variety of landscape treatment. Each of the various county groups has developed its own court treatment through the efforts of the landscape architects for the courts and in cooperation with the landscape architect for the Commission. The buildings and courts, varying as they do, through an extremely wide range of architecture from the old Spanish mission to the most modern buildings of today, offer a wide range of landscape treatment together with its maddening problem of getting some sort of unity in such treatment. As to the maddening quality of this work, I, as landscape architect for the California Commission, can testify. It is a good deal like trying to work out a boulevard planting with each property owner and resident along that boulevard insisting upon the two or three trees upon which his property front being his favorite tree. Bill Jones wants acacias; John Smith wants elms; Brown wants sycamores; and Casey wants Irish yews.

The plan for the boulevards passing through the California section may not please all of the group as to their individual likes or dislikes, but it has crystallized and is being planted to *Pitiosporum undulatum* in groups of three in a straight line with *magnolia grandiflora* at the intersection of the California Court and the avenue, and with accents of *Eugenia myrtifolia*. Other trees that are being used along the buildings are incense cedar, Monterey pine, Lawson cypress, *Pinus strobus* and *Sequoia gigantea*. These are relieved by shrubbery such as *abelia*, *oleanders*, *cryptomeria*, Oregon grape, *coton-easters* and laurel. Twenty-three thousand *leptospermum laevigatum* have been grown by the Highway Division for the State of California to be used for border hedges throughout this California division. Due to the fact that the work on the many buildings for the California

Commission could not be started until the early part of 1938, it was impossible to sow lawn seed and get sufficient stands to make a showing by the opening of the Exposition. Consequently the Highway Division of the State was employed to grow fifty thousand square feet of sod which was brought to the Exposition grounds from Sacramento only a few days before the Fair opened.

State University's Contribution

Perhaps one of the most interesting features of the California Division will be the work that is to be done by the University of California in the California Court and along the main avenue. The University, under direction of Dr. Goodspeed, was paid to import plants from Chili, Peru and other South American countries to fill certain beds and keep them in constant bloom throughout the year 1939. Most of these plants have never been seen by the layman, and are of startling beauty and character. In addition to these exotics, the University is supplying a group of camelias, comprising thirty-one varieties, which will be set out for bloom in February and March. This same group also includes six varieties of azalea and twelve varieties of rhododendrons.

In April will follow some fifty more varieties of rhododendrons, together with five more of azaleas, which will be relieved by masses of primula, alstroemeria, and corydalis. In July the University display will show forty varieties of lilies, followed by a small display of calendria.

In the fall will be displayed calceolaria, hippeastrums, eustephias and a great variety of fall blooming plants. Altogether, Dr. Goodspeed and his assistant, Mr. Brydon, director of the botanic gardens at the university, will have on display throughout the year 35,000 plants in full flower that have been gathered and prepared during the entire year of 1938.

One item of unique interest will be the landscape work in the Chinese Village, which, although it is a concession and on the Gayway, will present many features of culture in China that are known only to those who have spent years in that beleaguered country. The Chinese syndicate that is building the two acres of buildings, all done in authentic classical archi-

ture and buildings varying from twelve feet in height to the steel-framed pagoda, 130 feet high, have expressed the desire that no plants shall be used in their village which are not indigenous to China, or at least in general use there. This means that such lovely trees and shrubs as sophora japonica, pomegranate, osmanthus, camellia, flowering peach and cherry, mulberry, the Chinese magnolia, and the famous Gingko, will be used in the larger plantings while for shrubbery, paeonias, azaleas, astilbe, chrysanthemums and rice plants will add the color. The Chinese Village will therefore be one place where he who cries for consistency, may spend comforting hours.

Adequately to cover the subject of the landscape treatment of the Golden Gate International Exposition in one article is like trying to do a mural on a postage stamp. I can only hope that the foregoing fragmentary comments may serve to inspire those who read it to make sufficient journeys to Treasure Island to substantiate my statements or perhaps to have the satisfaction of convincing themselves that here and there I have not done the subject justice.

BIRTH OF AN EXPOSITION

(Concluded from Page 24)

so far as PWA funds were concerned. These enforced conditions, combined with other requirements in the Federal applications, naturally determined the sequence of the entire construction operation (utilities, transportation facilities, water supply, and other features), which was laid out in general before a working organization was assembled.

A conception of the problem confronting the Exposition's department of works may be had from the fact that requirements included construction of a city occupying some 400 acres in the middle of the bay, at a location where water depths ranged up to 26 feet and averaged about 14 feet.

Creating the site and building the Exposition upon it called for a comprehensive staff whose assembly was left entirely to the director of works. He decided to divide the department into several divisions, each with its own chief, as follows: reclamation, structural engineering,



PAN AMERICAN PAVILIONS.—IN THE FOREGROUND IS PART OF THE PANAMA BUILDING WITH EL SALVADOR'S PAVILION IN THE BACKGROUND
DESIGNED BY DIVISION OF ARCHITECTS, G.G.I.E.

architecture, water supply and sanitation, roads and bridges, electrical engineering, mechanical engineering, estimating, transportation, horticulture, construction, specifications, general office management. These divisions are responsible to the director of works for the physical creation of the Exposition.

Concurrently, an architectural commission, composed of five San Francisco architects, was selected, although all working drawings and specifications were prepared by the department of works. The rough preliminary sketches, prepared in accord with ideas of the Commission, were estimated as to total cost, and modified by the director of works to meet the original assumptions. The rough estimates of gross construction cost indicated in the report of May, 1934, was somewhat increased because of a rise in the material and labor market, but under rigid control, the estimates submitted in 1936 have not been exceeded. As this is written

the work has progressed to such an extent that it is safe to say that the project will be completed within the budget.

The organization problem for the physical creation of an exposition is, perhaps, unlike that for any other type of construction. There are required men of exceptional ability to head the various divisions of the works department, gathered together for a comparatively short period of time, and working under high pressure. Throughout this undertaking effort has been made to establish a spirit of cooperation that is rather unusual in an organization designed to function at top speed for a limited period and thereafter to be disbanded.

The Exposition company has spent nearly \$20,000,000, entirely apart from the cost of construction by participants, under supervision of the department of works, and it is to the engineers and architects of the several divisions that full credit should be given for the successful completion of this great enterprise.

Public Buildings

State and County Group at Treasure Island

COVERING some 80,000 square feet—or the area of an average city block, the California Building at the Fair is of modern design and 60 feet in height. Housing a Hall of Peace, commodious exhibit halls, auditoriums and ball rooms, and including a large outdoor amphitheater and spacious exterior terraces, every facility for administration and entertainment has been provided.

Appreciating the obligation resting on the host, architects for the California State Commission have paid meticulous attention to every detail. Beauty, comfort, utility and efficiency combine to produce quarters which will enable the State to entertain properly; to function efficiently.

Among many interesting features, the following are worthy of note: The main foyer contains information booths—with a guide service for the various county buildings—check rooms and comfortable seating arrangements both in the main hall and in the gallery. Works of art by prominent State artists are displayed around the main foyer and halls.

Particular attention has been devoted to comfort and convenience for women's activities. Spacious quarters off the foyer accommodate a lounge, dining room, several assembly rooms, a mother's rest room, and first aid quarters.

Supplementing a large ball room, sufficiently large to comfortably seat 1200 persons at a banquet, are two small auditoriums.

Stately in architectural treatment are outside terraces off the women's quarters and the ball room. Each overlooks an attractive garden.

To the right of the main foyer a dignified Hall of Peace—large and impressive—is graced by attractive murals. A rostrum and all facilities for holding meetings are provided.

Outstanding among the exhibits of natural resources displayed are the Fish and Game Division, the Forestry Department, the State Park Department and the Division of State Highways.

Unique in treatment is the colonnaded porch—reminiscent of the hospitable exteriors of the Old South—with the main entrance (viewed to the left of the photo) which displays a large mural 50 feet in height by 300 feet in length.

T. L. Pflueger officiated as supervising architect for the California State Commission.

COUNTY GROUP BUILDINGS

The following notes summarize highlights of the architectural treatment of the various county groups:

San Francisco, supervising architect, Clarence A. Tantau, San Francisco.

Of modern design, in harmony with other buildings of the county group.

Distinctive features include a large terrace overlooking the landscaped grounds of the Mission Trails group, adjoining; an elaborate Oriental garden bordering the grounds of the adjacent Alameda-Contra Costa group; a central court, 70 feet by 100 feet, with large stone fountain.

Directly off the main grand court—40 feet in height—is a circular room 50 feet in diameter, which displays ten unusual dioramas depicting the history of San Francisco from 1806 to the present era.

Alameda-Contra Costa, supervising architect, Irving F. Morrow, San Francisco.

Modern in design, the building is in the form of a quarter circle.

In the rear a large enclosed court contains a spacious garden with an open loggia. Distinctive murals and outstanding sculptures of impressive size lend distinction to the treatment.

Two of the murals on the back wall of the loggia, one 12 feet by 70 feet and the other 12 feet by 90 feet, were painted by Marian Simpson, who has executed murals for the lobby of the Alameda County courthouse and a large scale mosaic for the San Francisco city hall.

Redwood Empire, supervising architects, W. G. Merchant and B. R. Maybeck of San Francisco.

Building is constructed entirely of California's world-famous redwood lumber.

Structure is commodious and unique in design, with the obvious intent of bringing the building material to the forefront for treatment of exterior surfaces.

Within a large courtyard, entirely surrounded by an old redwood split rail fence, is featured exhibits typical of the Redwood Empire.

Worthy of special note in the interior treatment of the building are nine large dioramas and some exceedingly attractive murals.

Mission Trails, supervising architect, Harold Edmondson of Los Angeles, Robert Stanton of Del Monte, associate.

Distinctive in treatment is the stately and graceful California mission — composite of seven outstanding missions: Santa Barbara, San Miguel, Ventura, San Fernando, San Juan Capistrano, San Luis Rey and San Gabriel.

Authentic in design and with meticulous attention being paid to every detail, a replica of the world-famed star window gracing the Mission Carmel sanctuary, cloisters from San Fernando, Santa Ynez and Santa Barbara, and dancing fountains, paint enchanting, never-to-be-forgotten pictures of old California.

A tiled dome, typical mission bells and distinctive sculpture contribute grace to the Mission Trails edifice. A large courtyard reproduces realistically typical scenes of a mission garden of 150 years ago.

Shasta-Cascade, supervising architect, Otto A. Deichmann of San Francisco.

Typifying the modern trend in architecture, in harmony with the Exposition theme, the spacious building of the Shasta-Cascade counties is ornamented on the facade by interesting

wood carvings, the work of Dudley C. Carter.

The interior contains large dioramas and a relief map.

An exceptionally large enclosed court in the rear features a campfire pit, modeled after similar circles in our national parks, with comfortable seats of hewn logs, to accommodate 500 visitors.

Sacramento Valley-Tahoe Region, supervising architect, Henry Howard of San Francisco.

Building is of typical modernistic design, constructed of plywood and corrugated metal, with brilliant exterior illumination by floodlighting.

Incorporating a novel spiral design, the structure covers an area of more than half a block long, with maximum heights and widths of 36 feet and 70 feet, respectively.

San Joaquin Valley, supervising architect, Ernest Born of San Francisco.

Modern in design, the principal architectural feature has to do with a main facade constructed entirely of corrugated glass, with unique treatment presenting a Venetian blind effect.

An attractive court, graced by a large fountain of symmetrical design, is supplemented by extensive landscaping.

Southern California, supervising architect, H. C. Chambers of Los Angeles.

Strictly modern, this distinctive structure reaches a height of nearly fifty feet and contains three large exhibit rooms.

A rotunda, 60 feet by 56 feet, affords entrance to a large court, half the size of a city block, which will feature plant life typical of the southland.

The interior decorations include two murals, each 120 feet in length and another 65 feet in length. These are supplemented by dioramas and transparencies not of the ordinary type.

Chris Siemer, one of the noted scenic artists of America, and Millard Sheets, distinguished painter, have done the murals.

Alta California, supervising architect, Ernest Born of San Francisco.

Plywood

8,000,000 Square Feet at Treasure Island

by *Wm. Jennings*

NOW comes plywood as an exterior construction material, perhaps to revolutionize the low-cost housing field!

When the world comes to Treasure Island to view the Golden Gate International Exposition, much interest on the part of those intimately concerned with architecture, the building industry, and homes, will center about the California State and County group of eighteen buildings, for in this group Douglas fir plywood is employed in all but two; and in these sixteen State buildings this material is an important construction factor in all but one.

In addition, plywood is spectacularly used in many other buildings on Treasure Island, including the Federal Building where the Super-Harbord hot-pressed weatherproof plywood panels have been finished, with two coats of transparent Laux Rez, in a shiny natural color providing an effective contrast to the majority of the plywood-covered buildings which have been painted. Laux Rezitex, a heavy bodied plastic paint which has the added advantage of being fire resistant, was used on a number of plywood-covered buildings, including the Shasta-Cascade, Alameda-Contra Costa, San Joaquin Valley Counties and Los Angeles Southern Counties buildings. Engineers have shown particular interest also in the huge Super-Harbord plywood panels, 29-ply thick, which have been used as gusset plates in the construction of the 48 columns in the Colonnade of States.

Super-Harbord, weatherproof hot-pressed plywood with a cresol formaldehyde synthetic resin binder and then tempered, was used for the exterior covering and structural features of forty buildings on Treasure Island, thirteen of which are in the California State Group. On the Federal Building alone 500,000 square feet

of Super-Harbord was used, and numerous individual structures are covered with this weatherproof plywood including the Women's Club, Brazil Pavilion, Netherlands Building, French Pavilion and several restaurants and Gayway concessions.

The California State Building exterior is Resnprest weatherproof plywood, manufactured by the hot-pressed method, phenol, formaldehyde resin bonded. Resnprest has also been used on the Pacific Building, Auditorium and South Court Government Pavilion.

With these more dramatic uses of the exterior grade of Douglas fir plywood, literally acres of this material in the ordinary grades, suitable only for interior use, have been used in lining the buildings, in constructing exhibit booths, in providing temporary working structures, etc. Conservative estimates indicate that in excess of 8,000,000 square feet of plywood have been used at Treasure Island.

Conceding that the Golden Gate International Exposition is the first important World's Fair in which plywood is so generally employed, yet the architects and engineers concerned with the California building group naturally decline to term this use a "proving ground," in any sense, for this material. Had these architects and engineers been anything but satisfied that plywood would accomplish the required purposes, their specifications obviously would not have included this material.

In many of the important buildings, Douglas fir plywood not only covers practically all exterior surfaces, but is also a structural factor of importance. In view of this extensive use, coupled with extremes of humidity and wind pressure, it was agreed that the present year will yield ample proof of the value of plywood so employed.



Courtesy Coast Magazine

LATE PHOTOGRAPH OF FEDERAL BUILDING, TREASURE ISLAND
TIMOTHY L. PFLUEGER, ARCHITECT

Uncle Sam's contribution to the Fair consists of a majestic colonnade, a pair of huge WPA-executed murals and an all-over coating of plywood which, if it weathers well, may set a new style in construction materials. In front of the building is a vast plaza and artificial lake.

Favorable Factors

A brief summary of the situation on Treasure Island, where the California group of buildings occupies twelve acres, includes the following factors that are favorable from the standpoint of design and construction:

1. From the architect's viewpoint, plywood is an attractive material of excellent appearance, possessing the quality of scale. In order to meet all use conditions it is made in different grades and thicknesses, and in both the water-resistant type for interiors or covered exposure, and in the water-proof type for permanent exterior exposure.

2. It is easily applied, eliminates the necessity of sheathing from the standpoint of resistance to wind pressure.

3. The material comes sealed from the factory; it is ready primed—all surfaces and edges—although factory priming coat eliminates such necessity in the field.

4. Structurally strong, it is exceedingly light in weight.

5. Contracts provide that the exterior type of plywood material carry a guarantee insuring against any failure of plywood as to separation of the plies.

6. Panels are cut 4' x 8' or in odd or larger sizes upon order, and may be secured with a shiplap joint and V-edges.

7. Doing away with the necessity for plaster, plywood possesses the important advantage of ease of erection regardless of the weather. (As is well known, humidity must be carefully considered in plaster work.)

8. Due to rigidity and structural strength, plywood is called upon for main bracing elements. (It is so employed in State buildings.)

9. Plywood is being used for gussets, to simplify connections for bracing members in the field. This results in more rigid walls than are obtained in ordinary sheathed-wall construc-

tion. Because "exterior" plywood is hot-pressed under extreme pressure, with the employment of water-proof adhesives, a desirable, attractive, smooth surface results, without necessity of sanding.

It is probable that the California State group of buildings at the Golden Gate International Exposition represents the initial use of plywood as a major factor from the combined standpoint of coverage, ornamentation and the structural element. For this reason, it is believed that the architectural fraternity and the construction industry will study with deep interest the condition of those buildings into the construction of which Douglas fir plywood has entered, by the time the World's Fair of the West begins passing into history, in December, 1939.

As a central clearing house for the many questions that visitors to the Exposition will be asking, the Douglas Fir Plywood Association has made arrangements to have attendants experienced in the use of plywood in modern construction, at the booth in the Homes and Gardens Building.

The supervising architect of California State and Federal buildings on Treasure Island was Timothy L. Pflueger, A.I.A. Andrew White served as coordinator for the Federal Building; Clarence E. Seage, assistant executive officer in charge of design and construction for the State group; J. G. Wright, chief of the Division of Plans and Estimates, and S. S. Gorman, principal construction engineer.

FEDERAL GOVERNMENT'S DISPLAY

The United States Government's \$1,500,000 "Pageant of America" is the thrilling story of the creation of a new civilization in a new world.

Under the direction of George Creel, famous publicist and writer, the Federal exhibit on Treasure Island contains nothing static, nothing dull, everything alive with color, movement and significance.

The Federal display covers seven acres of ground space, of which about four acres, or

BARRETT & HILP

General Contractors

In addition to our regular construction activities in various parts of the United States we have completed the following work at the Golden Gate International Exposition on Treasure Island:

BUILDINGS	
Main Entrance Elephant Towers	National Cash Register
Court of Pacifica	Crillo Restaurant
California Coliseum	Treasure Island Milk Co.
Livestock Barn	Gayway Convenience Stations
Redwood Empire Building	EXHIBITS
Sacramento Valley Building	Terrarium
San Joaquin Valley Building	Sea Island Sugar
Mission Trails Wall	California Packing Corporation
Alta California Building	W.P.A. Recreation Pavilion
Southern Counties Building	Dr. Pierce Plastic Surgery
Missouri Building	Great Western Electro Chemical
Floriculture Building	Radio Corporation of America
Australian Building	Federal Building Flagpole
New Zealand Building	North Caunt Federal Building
California Building Interior	Pacific Building
Federal Building Interior and Paving	National Biscuit Company
Shasta Cascade Portico	Standard Brands
Latin American Group of nineteen buildings	General Sherman Tree
White Star Tuna Restaurant	Agricultural

BARRETT & HILP

Main Office — San Francisco

D. W. NICHOLSON
 GENERAL CONTRACTOR
 357 - 12th STREET
 OAKLAND

The following is a partial list of buildings and general construction work performed by us at the Golden Gate International Exposition —

- | | |
|--|-----------------------------------|
| Pan American Airways
—Shops—Offices | Midget Village |
| Press Reception Bldg. | Sally Rand Dude
Ranch |
| Penny Arcade | Life Show Building |
| Candid Camera | Hindu Temple |
| Paving, Chinese
Village | Highland Village |
| Holy City | Day Dream Building |
| Frozen Custard
Building | Souvenir Concession
Stands |
| Shooting Galleries
No. 1 and No. 2 | Deep Sea Divers |
| Snake Show | Giant Crane |
| Harvey Theatre | Miniature Railway |
| Paving, paths and
walks on State
Buildings | Sea Plane Base |
| | World's Largest
Horse Building |
| | Trading Post Building |

950 TONS of STEEL

for Tower of the Sun

Treasure Island

Fabricated and Erected by

Judson-Pacific Co.

1200 Seventeenth Street

SAN FRANCISCO

Phone DOuglas 4460

Plants: San Francisco - Oakland

200,000 square feet, is the site of the spectacular Government Building itself.

Designed by Timothy L. Pflueger, the main Federal Building has a total frontage of 665 feet. Through the center runs a Colonnade of the States—48 columns closely grouped, and 104 feet high, symbolizing the great American commonwealths. These are 40 feet higher than the flanking roofs. To the right and left of the Colonnade are open courts, the right one containing the WPA recreation exhibit and the Story of Housing, the left one enclosing a sylvan theater and the Indian court.

The building faces a great plaza, which in turn surrounds a lake and looks down the principal east-west axis of the Exposition between the stately East Towers toward the Court of Honor, the Tower of the Sun, and the main gates, the Portals of the Pacific. The building is impressively reflected in the lake.

This is one of the largest Federal exhibit buildings ever constructed, (three times as large as the United States exhibit at the New York World's Fair, 1939), and is certainly one of the most economically designed. Its cost of \$6.90 per square foot of exhibit space is about a tenth the cost of previous Federal exhibits at expositions. The reason for this is the fact that neither time nor money were spent on fuss and feathers, elaborate entertainments or anything of that kind. For example, the proportional area for administrative offices is the smallest ever built in a Federal exhibit.

The principal subjects treated are:

- (1) The American Indian;
- (2) Conservation;
- (3) Social Affairs;
- (4) Economic Affairs;
- (5) The March of Science;
- (6) The Federal Theatre;
- (7) WPA Art;
- (8) WPA Recreation;
- (9) Housing;
- (10) National Defense and the Coast Guard.

NAMED PRESIDENT

C. M. Winslow of Los Angeles, has been elected president of the California Society, Sons of the Revolution.

OTHER BUILDINGS AND THEIR ARCHITECTS

In addition to the Exposition company's palaces and courts, the following is a list of buildings on the Island with the name of the designer of each building wherever it has been possible to obtain it:

BUILDING	ARCHITECT
I. Federal Building	Timothy Pflueger
II. Foreign Buildings	
1. France	Georges Besse and Claude Meyer-Levy; Eldridge T. Spencer associate.
2. Argentine	Armando d'Ans.; Wm. W. Wurster, consultant.
3. Brazil	Gardner A. Dailey
4. Italy	Alfo Susini; Peter Canali, consultant.
5. Norway	
6. Pacific House	William G. Merchant
7. French Indo-China	Georges Besse and Claude Meyer-Levy; Eldridge T. Spencer, associate.
8. Netherland East Indies Pavilion & Restaurant.	Robert Deppé; Timothy Pflueger consultant.
9. Johore Pavilion	
10. Japan	
11. Latin-American Court	Division of Architecture
Ecuador	" " "
Chili	" " "
Peru	" " "
Guatemala	" " "
Costa Rica	" " "
Panama	" " "
El Salvador	" " "
Mexico	" " "
Colombia	Pablo de la Cruz and Rafael Ruiz
12. Australia	Division of Architecture
13. New Zealand	" " "
14. Philippines	Gregoria P. Gutierrez
15. Hawaii	L. P. Hobart
III. State Buildings	
1. Calif. Bldg. and Auditorium	Timothy Pflueger
2. Western States Building	Division of Architecture
3. Illinois	
4. Missouri	
IV. County Buildings	Timothy Pflueger, architect in chief
(See text pages 51-52)	
V. Miscellaneous Buildings	
1. Yerba Buena Club	W. W. Wurster, architect
2. Chinese Concession	Mark Daniels, architect
3. Ghirardelli	Bakewell & Weihe, architects
4. Oakwood Barbecue	Wm. G. Merchant, architect
5. Bank of America	
6. Owl Drug Co.	
7. Gay Way (as a whole)	
8. Temple of Religion	
9. Cash Register	
10. Christian Science Activities	
11. Christian Business Men's Association	
12. Western Pine Association	
13. Compton Metal House	
14. Hindustan Temple	



VISIT THE JOHNS-MANVILLE EXHIBIT
IN THE HOMES & GARDENS BUILDING

See

ASBESTOS--the *Magic Mineral*

This exhibit dramatizes the vast improvements in modern building materials. By means of interesting displays and motion pictures, the J-M exhibit will show the wonders that can be accomplished in *new home* construction, *home modernization*, commercial buildings, and industrial plants.

You will also be interested in seeing additional J-M exhibits showing Asbestos and Celite Products within Treasure Mountain located in the Mining Building.

JOHNS-MANVILLE

California Factories
LOS ANGELES • PITTSBURG • LOMPOC
REDWOOD CITY • WATSON

A good investment—

is a well designed, well built,
structure, properly located.

Lindgren & Swinerton, Inc.

have been building substantial
buildings for over a half of a cen-
tury, are still building them and
will continue building them for
another half of a century.

Lindgren & Swinerton, Inc.

Standard Oil Building
San Francisco
619 H Street
Sacramento

605 W. Olympic Boulevard
Los Angeles
1723 Webster Street
Oakland

EXPOSITION BUILDERS

CONCRETE FLOOR

IN THE
FEDERAL BUILDING

TIMOTHY L. PFLUEGER, Architect

GOLDEN GATE INTERNATIONAL EXPOSITION

by

LOUIE SARTORIO

CONCRETE CONSTRUCTION

2627 LOMBARD STREET or BUILDERS EXCHANGE
Phone WALnut 5126 San Francisco

TACOMA MILLWORK SUPPLY CO.

MANUFACTURERS OF HIGH CLASS

DETAIL MILLWORK
HARD AND SOFT WOODS

LOUIS LePAGE

MANAGER CALIFORNIA SALES OFFICE

580 MARKET ST., SAN FRANCISCO
PLANT: TACOMA, WASHINGTON

Spencer Electric Co.

Electrical Contractors for
CALIFORNIA BUILDING
ARGENTINE PAVILION
and other Exposition structures

570 Natoma Street, San Francisco

Chas. Stockholm & Son

General Contractors
Russ Building, San Francisco

●
Builders of

EXPOSITION WOMEN'S CLUB BUILDING
W. W. WURSTER, Architect

AND

PAVILION FOR THE UNITED STATES OF BRAZIL
GARDNER A. DAILEY, Architect

AT THE EXPOSITION



LINOLEUM MURAL DRAMATIZES HISTORY OF SHELTER

Here is a photographic reproduction of an all-linoleum mural of a New England Colonial Home, being one section of a huge mural depicting "The History of Shelter." It is an artistic and unusual interpretation of progress in home construction from prehistoric times down to the present day. The panel is a feature of the exhibit of the Paraffine Companies, Inc., at the Golden Gate International Exposition.

Twenty-seven different patterns of Pabco linoleum were used in fashioning the unique panorama. Miss Sandra Grey (only linoleum model in the world) posed for the New England maid in the panel.

The mural is the world's largest linoleum mural, so far as known.

CENTRAL ELECTRIC Co.

J. M. Carlson

D. H. Carlson

E. W. Carlson

*Some of the buildings at Treasure Island
illuminated by us:*

Women's Club House
Western States Bldg.
Mission Trails Bldg.
Southern Counties Bldg.
Shasta Cascade Bldg.
Illinois Bldg.
Parking Area

Calvacade Grandstand
Lake Tahoe
Nippon Pavilion
Missouri Exhibit
Four Main Exhibit Palaces
Various exhibits in
Main Palaces

179 Minna Street, San Francisco
Phone EXbrook 2180

Estimator's Guide

Giving Cost of Building Materials, Wage Scale, Etc.

Amounts given are figuring prices and are made up from average quotations furnished by material houses to San Francisco contractors. 3% Sales Tax on all materials but not labor.

All prices and wages quoted are for San Francisco and the Bay District. There may be slight fluctuation of prices in the interior and southern part of the state. Freight charge at least, must be added in figuring country work.

Bond— $1/2\%$ amount of contract.

Brickwork—

Common, \$40 to \$45 per 1000 laid, (according to class of work).

Face, \$100 to \$110 per 1000 laid, (according to class of work).

Brick Steps, using pressed brick, \$1.25 lin. ft.

Brick Veneer on frame buildings, \$.75 sq. ft.

Common f.o.b. cars, \$14.00 at yard. Cartage extra.

Face f.o.b. cars, \$45.00 to \$50.00 per 1000 carload lots.

HOLLOW TILE FIREPROOFING (f.o.b. job)

3x12x12 in. \$ 84.00 per M
4x12x12 in. 94.50 per M
6x12x12 in. 126.00 per M
8x12x12 in. 225.00 per M

HOLLOW BUILDING TILE (f.o.b. job)

carload lots.
8x12x5/2 \$ 94.50
6x12x5/2 73.50

Building Paper—

1 ply per 1000 ft. roll \$3.50
2 ply per 1000 ft. roll 5.00
3 ply per 1000 ft. roll 6.25
Brownskin, 500 ft. roll 4.50
Brownskin, Pro-tect-o-mat, 1000 ft. roll 9.00
Sisalcraft, 500 ft. roll 5.00
Sash cord com. No. 7 \$1.20 per 100 ft.
Sash cord com. No. 8 1.50 per 100 ft.
Sash cord spot No. 7 1.90 per 100 ft.
Sash cord spot No. 8 2.25 per 100 ft.
Sash weights cast iron, \$50.00 ton.
Nails, \$3.50 base.
Sash weights, \$45 per ton.

Concrete Aggregates—

Gravel (all sizes) \$1.45 per ton at bunker; delivered to any point in S. F. County \$1.85.

	Bunker	Delivered
Top sand	\$1.45	\$1.85
Concrete mix	1.45	1.85
Crushed rock 1/4 to 3/4	1.60	2.00
Crushed rock, 3/4 to 1 1/2	1.60	2.00
Roofing gravel	1.60	2.00
City gravel	1.45	1.85
River sand	1.40	1.80
Delivered bank sand—\$1.00 per cubic yard at bunker or delivered.		

SAND—

	Bunker	Delivered
River sand	\$1.40	\$1.80
Lepis (Nos. 2 & 4)	2.00	2.40
Olympia Nos. 1 & 2	1.80	2.20
Headburg plaster sand	\$1.80 and \$2.20	
Del Monte white	50c per sack	

CEMENT (all brands, cloth sacks) \$2.72 per bbl., f.o.b. car, deliv. \$2.90 per bbl. carload lots; less than carload lots, warehouse or delivered, 60c per sack. (Less 10c per sack returned, 2% 10th Prox.)

Common Cement (all brands, paper sacks) carload lots \$2.52 per bbl., f.o.b. car, delivered, \$2.70; less than carloads delivered, 75c per sack. Discount on cloth sacks, 10c per sack. Cash discount on carload lots, 10c a barrel, 10th Prox.; cash discount less than carload lots, 2%.

Atlas White } 1 to 100 sacks, \$1.50 sack.
Calaveras White } warehouse or delivery; over 100
Medusa White } sacks, \$1.25; 2% discount 10th
of month.

Forms, Labors average \$40.00 per M.
Average cost of concrete in place, exclusive of forms, 35c per cu. ft.; with forms, 60c.
4-inch concrete basement floor 12 1/2c to 14c per sq. ft.
Ret-roofing 7 1/2c
Concrete Steps \$1.25 per lin. ft.

Dampproofing and Waterproofing—

Two-coat work, 20c per yard.
Membrane waterproofing—4 layers of saturated felt, \$4.50 per square.
Hot coating work, \$1.80 per square.
Medusa Waterproofing, 15c per lb., San Francisco Warehouse.
Tricoel waterproofing.
(See representative.)

Electric Wiring—\$12.00 to \$15.00 per outlet for conduit work (including switches). Knob and tube average \$3.50 per outlet.

Elevators—

Prices vary according to capacity, speed and type. Consult elevator companies. Average cost of installing an automatic elevator in four-story building, \$2800; direct automatic, about \$2700.

Excavation—

Sand, 60 cents; clay or shale \$1 per yard.
Teams, \$12.00 per day.
Trucks, \$22 to \$27.50 per day.
Above figures are an average without water. Steam shovel work in large quantities, less; hard material, such as rock, will run considerably more.

Fire Escapes—

Ten-foot galvanized iron balcony, with stairs, \$115 installed on new buildings; \$140 on old buildings.

Floors—

Composition Floors—22c to 40c per sq. ft. In large quantities, 16c per sq. ft. laid.
Mosaic Floors—80c per sq. ft.
Duraflex Floor—23c to 30c sq. ft.
Rubber Tile—50c to 75c per sq. ft.
Terazo Floors—45c to 60c per sq. ft.
Terazo Steps—\$1.60 lin. ft.

Hardwood Flooring (delivered to building)—
1 1/2"x2 1/2" T & G Maple \$ 88.00 M ft.
1 1/2"x2 1/2" T & G Maple 115.00 M ft.
7/8"x3 1/2" sq. edge Maple 100.00 M ft.

	1 1/2"x2 1/2"	3 1/2"x2"	5/8"x2"
	T & G	T & G	5/8 Ed.
Clr. Old. Oak	\$120.00 M	\$ 82.50 M	\$110 M
Sel. Old. Oak	99.00 M	69.50 M	84 M
Clr. Pla. Oak	106.00 M	74.50 M	86 M
Sel. Pla. Oak	97.00 M	62.50 M	76 M
Clear Maple	111.00 M	100.00 M	
Laying & Finishing	14c ft.	12c ft.	10c ft.
Wage—Floor layers, \$10.00.			

Note—Above quotations are all board measure except last column which is sq. ft.

Glass (consult with manufacturers)—

Double strength window glass, 20c per square foot.
Plate 75c per square foot (unglazed) in place, \$1.00.
Art, \$1.00 up per square foot.
Wire (for skylights), 40c per sq. foot.
Obscure glass, 30c square foot.
Glass bricks, \$2.40 per sq. ft., in place.
Note—If not stipulated add extra for setting.

Heating—

Average, \$1.90 per sq. ft. of radiation according to conditions.
Warm air (gravity) average \$40 per register.
Forced air, average \$60 per register.

Iron—Cost of ornamental iron, cast iron etc., depends on designs.

Lumber (prices delivered to bldg. site).

No. 1 common	\$29.00 per M
No. 2 common	27.00 per M
Select O. P. common	34.00 per M
2x4 No. 3 form lumber	24.00 per M
1x4 No. 2 flooring VG	55.00 per M
1x4 No. 3 flooring VG	47.00 per M
1x6 No. 2 flooring VG	60.00 per M
1 1/4x4 and 6, No. 2 flooring	60.00 per M
Slash grain—	
1x4 No. 2 flooring	\$43.00 per M
1x4 No. 3 flooring	40.00 per M
No. 1 common run T. & G.	30.00 per M
Lath	5.25 per M
Shingles (add cartage to price quoted)—	
Redwood, No. 1	\$1.10 per bble.
Redwood, No. 2	.90 per bble.
Red Cedar	1.10 per bble.

Plywood—Douglas Fir (add cartage)—

"Plyscord" sheathing (unsanded)
5/16" 3-ply and 48"x96" \$30.00 per M
Wallboard Grade (sound one side)—
1 1/4" 3-ply 48"x96" \$37.50 per M
Concrete Form Panels (special core & glue)
5/8" 5-ply 48"x96" \$110.00 per M
If tiled \$5.00 extra per M

Millwork—Standard.

O. P., \$85.00 per 1000. R. W., \$90.00 per 1000 (delivered).
Double hung box window frames, average with trim, \$6.50 and up, each.
Doors, including trim (single panel, 1 3/4 in. Oregon pine) \$8.00 and up, each.
Doors, including trim (five panel, 1 3/8 in. Oregon pine) \$6.00 each.
Screen doors, \$3.50 each.
Patent screen windows, 25c a sq. ft.
Cases for kitchen pantries seven ft. high per lineal ft., \$8.00 each.
Dining room cases, \$8.00 per lineal foot.
Rough end finish about 75c per sq. ft.
Labor—Rough carpentry, warehouse heavy framing (average), \$17.50 per M.
For smaller work average, \$35.00 to \$45.00 per 1000.

Marble—(See Dealers)

Painting—

Two-coat work	36c per yard
Three-coat work	50c per yard
Cold Water Painting	10c per yard
Whitewashing	4c per yard
Turpentine, 65c per gal., in 5 gal. cans, and 55c per gal. in drums.	
Raw Linseed Oil—97c gal. in bbls.	
Boiled Linseed Oil—\$1.00 gal. in bbls.	
Medusa Portland Cement Paint, 20c per lb.	

Pioneer or Dutch Boy White Lead in Oil (in steel kegs). Per Lb.

1 ton lots, 100 lbs. net weight.....	10/4c
500 lbs. and less than 1 ton lots.....	10/2c
Less than 500 lb. lots.....	11c

Pioneer or Dutch Boy Red Lead and Litharge (in steel kegs).

1 ton lots, 100 lb. kegs, net weight.....	10/4c
500 lbs. and less than 1 ton lots.....	10/2c
Less than 500 lb. lots.....	11c

Pioneer Red Lead in Oil (in steel kegs)

1 ton lots, 100 lb. kegs, net weight.....	11/4c
500 lbs. and less than 1 ton lots.....	11/2c
Less than 500 lb. lots.....	12c

Note—Accessibility and conditions cause some variance in costs.

Patent Chimneys—

6-inch	\$1.25 lineal foot
8-inch	1.75 lineal foot
10-inch	2.25 lineal foot
12-inch	3.00 lineal foot

Plastering—Interior—

1 coat, brown mortar only, wood lath.....	Yard \$0.75
2 coats, lime mortar hard finish, wood lath.....	.80
3 coats, metal lath and plaster.....	1.50
Keece cement on metal lath.....	1.60
Ceilings with 3/4 hot roll channels metal lath.....	.90

Ceilings with 3/4 hot roll channels metal lath plastered.....	1.65
Single partition 3/4 channel lath 1 side.....	.85
Single partition 3/4 channel lath 2 sides 2 inches thick.....	1.50
4-inch double partition 3/4 channel lath 2 sides.....	1.30
4-inch double partition 3/4 channel lath 2 sides plastered.....	3.00

Plastering—Exterior—

2 coats cement finish, brick or concrete wall.....	Yard \$1.00
2 coats Calaveras cement, brick or concrete wall.....	1.35
3 coats cement finish, No. 18 gauge wire mesh.....	1.50
3 coats Calaveras white finish, No. 18 gauge wire mesh.....	1.75

Wood lath, \$7.50 to \$8.00 per 1000.....	1.75
2.5-lb. metal lath (dipped).....	.20
2.5-lb. metal lath (galvanized).....	.22
3.4-lb. metal lath (dipped).....	.20
3.4-lb. metal lath (galvanized).....	.28
3/4-inch hot roll channels, 972 per ton.....	
Finish plaster, \$18.90 ton; in paper sacks.	
Dealer's commission, \$1.00 off above quotations.	
\$13.85 (rebate 10c sack).	
Lime, f.o.b. warehouse, \$2.25 bbl.; cars, \$2.15 lme, bulk (ton 2000 lbs.), \$16.00 ton.	
Wall Board S ply, \$50.00 per M.	
Wynale Lime, \$19.50 ton.	

Plasterers Wage Scale	\$1.25 per hour
Lathers Wage Scale	1.25 per hour
Hod Carriers Wage Scale	1.10 per hour

Composition Stucco—\$1.80 to \$2.00 per sq. yard (applied).

Plumbing—

From \$70.00 per fixture up, according to grade, quantity and runs.

Roofing—

"Standard" tar and gravel, \$6.50 per sq. for 30 sas. or over.	
Less than 30 sas. \$7.00 per sq.	
Lite, \$20.00 to \$35.00 per square.	
Redwood Shingles, \$7.50 per square in place.	
Copper, \$16.50 to \$18.00 per sq. in place	
Cedar Shingles, \$8.00 per sq. in place.	
Recoat, with Gravel, \$3.00 per sq.	
Asbestos Shingles, \$15 to \$25 per sq laid.	

Slate, from \$25.00 to \$50.00 per sq. yard, according to color and thickness.	
Shakes—1x25" resawn	\$11.50 per sq
1/2x25" resawn	10.50 per sq
1/2x25" tapered	10.00 per sq.

Sheet Metal—

Windows—Metal, \$1.75 a sq. foot.
Fire doors [average], including hardware \$1.75 per sq. ft.

S skylights—(not glazed)

Copper, 90c sq. ft. (flat).
Galvanized iron, 30c sq. ft. (flat).
Vented hip skylights 60c sq. ft.

Steel—Structural

\$120 ton (erected), this quotation is an average for comparatively small quantities. Light truss work higher. Plain beams and column work in large quantities \$90 to \$100 per ton.

Steel Reinforcing—

\$80.00 to \$120.00 per ton, set.

Stone—

Granite, average, \$6.50 cu. foot in place
Sandstone, average Blue, \$4.00, Boise \$3.00 sq. ft. in place.
Indiana Limestone, \$2.80 per sq. ft. in place.

Store Fronts—

Copper sash bars for store fronts, corner, center and around sides, will average 75c per lineal foot.

Note—Consult with agents.

Tile—Floor, Wainscot, etc.— (See Dealers)
Asphalt Tile—18c to 28c per sq. ft. installed.

Wall Tile—

Glazed Terra Cotta Wall Units (single faced) laid in place—approximate prices	
2 x 6 x 12	\$1.00 sq. ft.
4 x 6 x 12	1.15 sq. ft.
2 x 8 x 16	1.10 sq. ft.
4 x 8 x 16	1.30 sq. ft.

Veneer Blinds—

40c per square foot and up. Installation extra.

THE BUILDERS' EXCHANGE OF SAN FRANCISCO STANDARD WAGE SCALE

For mechanics employed on construction work in the Bay Region. Effective September 1, 1937

CRAFT	Journeymen Mechanics
Asbestos Workers	\$ 8.00
Bricklayers (6h-5d)	10.50
Bricklayers' Hodcarriers (6h-5d)	6.75
Cabinet Workers (Outside) (5d)	6.40
Caisson Workers (Open)	6.40
Carpenters (8h-5d)	10.00
Cement Finishers (8h-5d)	10.00
Cork Insulation Workers (8h-5d)	9.00
Electric Workers (8h-5d)	11.00
Electrical Fixture Hangers	8.00
Elevator Constructors	10.40
Engineers, Portable & Hoisting	9.00
Glass Workers (8h-5d)	9.68
Hardwood Floormen	9.00
Housmiths, Architectural Iron (Shop) (8h-5d)	9.00
Housmiths, Architectural Iron (Outside) (8h-5d)	10.00
Housmiths, Reinforced Concrete or Rodmen (8h-5d)	10.00
Iron Workers (Bridge and Structural) Including Engineers (8h-5d)	12.00

CRAFT	Journeymen Mechanics
Laborers, Building (8h-5d)	\$ 6.00
Laborers, Common (8h-5d)	6.00
Lathers, Channel Iron (6h-5d)	9.00
Lathers, All Others	9.00
Marble Setters (8h-5d)	10.50
Marble Setters' Helpers (8h-5d)	5.50
Millwrights	9.00
Model Makers (\$1.50 per hr-6h)	9.00
Modelers (\$2 per hr-6h)	12.00
Model Casters	7.20
Mosaic and Terrazzo Workers (Outside)	9.00
Painters (7h-5d)	8.50
Painters, Varnishers and Polishers (Outside)	9.00
Pile Drivers and Wharf Builders	9.00
File Drivers' Engineers	10.00
Plasterers (6h-5d)	10.00
Plasterers' Hodcarriers (6h-5d)	7.50
Plumbers (8h-5d)	11.00
Roofers, Composition (8h-5d)	9.00
Roofers, All Others (8h-5d)	8.00
Sheet Metal Workers (8h-5d)	10.00
Sprinkler Fitters	10.00

CRAFT	Journeymen Mechanics
Steam Fitters (8h-5d)	\$11.00
Stair Builders (8h-5d)	9.00
Stone Cutters, Soft and Granite (8h-5d)	9.00
Stone Setters, Soft and Granite	12.00
Stone Derricemen	9.00
Tile Setters (8h-5d)	11.00
Tile Setters' Helpers (8h-5d)	6.50
Tile, Cork and Rubber (8h-5d)	9.00
Welders, Structural Steel Frame on Buildings	11.00
Welders, All Others on Buildings	9.00
Dump Truck Drivers, 2 yards or less	6.00
Dump Truck Drivers, 3 yards	6.50
Dump Truck Drivers, 4 yards	7.00
Dump Truck Drivers, 5 yards	7.00
Dump Truck Drivers, 6 yards	7.50
Truck Drivers of Concrete Mixer Trucks: 2 yards or less	6.50
3 yards	7.00
4 yards	7.50
5 yards	7.50
6 yards	8.00

GENERAL WORKING CONDITIONS

- Eight hours shall constitute a day's work for all crafts except as otherwise noted.
- Plasterers' Hodcarriers, Bricklayers' Hodcarriers, Roofers' Laborers, and Engineers, Portable and Hoisting, shall start 15 minutes before other workmen, both at morning and at noon.
- Five days, consisting of not more than eight hours a day, on Monday to Friday inclusive, shall constitute a week's work.
- Transportation costs in excess of twenty-five cents each way shall be paid by the contractor.
- Overtime shall be paid as follows: For the first four hours after the first eight hours, time and one-half. All time thereafter shall be paid

- double time, Saturdays (except Laborers), Sundays and holidays, from 12 midnight of the preceding day, shall be paid double time.
- On Saturday, Laborers shall be paid straight time for an eight-hour day.
- Where two shifts are worked in any twenty-four hours, shift time shall be straight time. Where three shifts are worked, eight-hour's pay shall be paid for seven hours on the second and third shifts, allowing one-half hour for lunch.
- All work, except as noted in paragraph 9, shall be performed between the hours of 8 a.m. and 5 p.m.
- In emergencies, or where premises cannot be vacated until the close of business, men then

- reporting for work shall work at straight time. Any work performed on such jobs after midnight shall be paid time and one-half up to four hours of overtime and double time thereafter, provided, that if a new crew is employed on Saturdays, Sundays or holidays which has not worked during the five preceding days, such crew shall be paid time and one-half.
- Recognized holidays to be: New Year's Day, Decoration Day, Fourth of July, Labor Day, Admission Day, Thanksgiving Day, Christmas Day.
- Men ordered to report for work, for whom no employment is provided, shall be entitled to two hours' pay.

ARCHITECTS' BULLETIN

Issued For

THE STATE ASSOCIATION OF CALIFORNIA ARCHITECTS
Northern Section

Architectural Practice Act

THE newly codified Act has been introduced into the California State Legislature, and no opposition is expected to its confirmation. Members have received copies of the proposed Act, and are expected to use all legitimate means to further its passage. This can best be accomplished by making sure that local assemblymen and senators are informed that no essential changes are made from the existing Act, but that it becomes more truly a purely professional licensing Act which controls the proper practice of architecture by architects.

• **OTHER LEGISLATION** • The Legislative committee, and the Executive Boards, of the Association, are keeping in touch with several proposed bills which affect the building industry and the architectural profession. It is a big job to discover and investigate all such proposed legislation, but our committee is devoting considerable time and study to the whole situation, with some outside expert assistance. Whenever it appears that our members should be specifically informed of inequitable legislation, and enlisted in organized opposition, they will hear directly from the Executive Board.

Already one such bill has been found to threaten the fair minimum fee schedule approved by the Association. It is in duplicate form, Assembly Bills Nos. 752 and 753 (amending the Architectural Act and the Business and Professions Code) and fixes definite limited fees for architectural service on all public buildings. This would, of course, injure public welfare by reducing the service which architects can afford to furnish. Certainly no one should be expected to work for the State at a loss, or without a fair, reasonable profit. Facts in this situation are easily demonstrable, and the Association will oppose these bills as drawn, with determination and with a clear conscience.

• **ASSOCIATION OFFICE** • Again the members are reminded that the office of the Association at 557 Market Street, San Francisco, is open daily from 9:30 A.M. to 1:00 P.M., Mondays to Fridays inclusive. All calls and phone messages (DOuglas 4561) should be made during those hours when the faithful office secretary, Mrs. Milton (nee' Kragen) will give sympathetic consideration and information. Subscription dues will also be received and receipted—and welcomed for the important work of this year.

BUILDING STATISTICS

Answering a general demand for such information, The Architect and Engineer, commencing with the March issue, will publish a page of building statistics on the Pacific Coast.

Compiled from reliable sources, the information will indicate present-day trends in building with classification of types of construction and comparisons with volume of work for the same period a year ago.

STATE ASSOCIATION MEMBER OF THE AMERICAN INSTITUTE OF ARCHITECTS Editor

Harris C. Allen

Address all communications for publication in the Bulletin to the Editor (Harris C. Allen) 557 Market Street, Room 218, San Francisco, California.

Board of Control

Harris C. Allen Otto G. Hintermann
Harry Michelsen Wayne S. Hertzka

State Association Officers

President Sylvanus B. Marston, Pasadena
Vice-President..... Gwynn Officer, Berkeley
Secretary Wayne S. Hertzka, San Francisco
Treasurer Robert H. Orr, Los Angeles

Regional Director, A. I. A.

Albert J. Evers, San Francisco
Deputy Regional Director, Southern California
Gordon B. Kaufmann, Los Angeles

Executive Board—Northern Section Officers

President Gwynn Officer, Berkeley
Vice-Pres. Ernest E. Weihe, San Francisco
Secretary Wayne S. Hertzka, San Francisco
Treasurer Otto G. Hintermann, San Francisco

Directors

Harry J. Devine R. H. Reimers
Wm. J. Merchant Harold Weeks

Executive Board—Southern Section Officers

President Sylvanus B. Marston
Vice-President Louis N. Crawford
Secretary Winsor Soule
Treasurer Robert H. Orr

Directors

Merrill W. Baird Abe Edelman
Harold C. Chambers George D. Riddle

Advisors—Northern Section

Harris C. Allen San Francisco
J. K. Ballantine, Jr. (Secretary)
Sam. Lightner Hymen
Wm. G. Merchant
Jas. F. McGuiness
Dodge A. Riedy
Harold H. Weeks
Ernest E. Weihe
Albert R. Williams
Fred. H. Reimers (President)
C. A. Caulkins North Bay District
Peter Sala Lower San Joaquin District
J. U. Cloudsley (Secretary)
Edw. W. Kress Santa Clara Valley
Mario Corbett San Mateo
Alden Cambell Sacramento
Ernest J. Kump Upper San Joaquin
Dole F. Thomsen Palo Alto
Norman W. Sexton Marin
Geo. P. Simonds East Bay
Chester Treichel East Bay
Gwynn Officer Berkeley
F. T. Georgeson Redwood Empire
Casebolt Dakin Upper Sacramento
Ralph Taylor Lassen District

NORTHERN CALIFORNIA CHAPTER

The regular and annual meeting of Northern California Chapter, A.I.A., was held at the St. Francis Yacht Club, San Francisco, Tuesday evening, January 31, Warren C. Perry presiding.

The following were present: Harris C. Allen, Wm. Clement Ambrose, John Bakewell Jr., Birge M. Clark, David B. Clark, Albert J. Evers, Wayne S. Hertzka, Lester Hurd, Raymond W. Jeans, Charles F. Masten, John B. McCool, Harry M. Michelsen, Chester H. Miller, James H. Mitchell, Irving F. Morrow, Warren C. Perry, Roland I. Stringham, Ernest E. Weihe, Wm. Wilson Wurster, Raymond Yelland and John Davis Young.

In keeping with the custom at annual meetings, Mr. Perry, the president, addressed the members on work that had been performed by the executive committee during the year. He also left with them impressions gained during his presidency which, if effected, would be helpful in the future activities of the Chapter.

In the secretary-treasurer's report that followed there was rendered an accounting of the finances and memberships in the Chapter that showed it to be sound and growing in each of these respects.

The report of the membership committee by Charles F. Masten, chairman, showed that this group had been hard at work during the year to build up memberships. Although the actual gain had not been great, it was felt that the committee's efforts would really bear fruit during the months to come.

Harry Michelsen reported for the committee on relations with the building industry. Special interest had been taken, he said, in the study of bid opening practices conducted by the Institute during the year. Other activities had centered in the Building Industry Conference Board, the California Construction Congress and Producers Council Club to effect a better correlation of the entire building industry. The California State Chamber of Commerce was complimented for its assistance in vital issues affecting the profession.

Mr. Perry, chairman of the committee on education and registration, spoke upon the new registration Act. With Mr. Wurster temporarily presiding, the motion presented by the speaker was unanimously carried, as follows:

"Moved, that the Chapter endorse the Registration Act as revised and now before the Legislature and urge upon the members to do all they can in behalf of its passage."

Next, speaking upon the Membership Plan and its benefit to students in gaining some practical office experience during their college career, Mr. Perry asked the Chapter to endorse the plan. With Mr. Wurster again presiding, the motion to this effect was unanimously carried.

Speaking of the amount in the education fund shown in the secretary-treasurer's report, it was proposed

that a sum approximating \$120 be transferred to it from the general funds. Mr. Jean's motion to effect this was regularly carried.

It was moved by Mr. Allen and carried that the executive committee at the second meeting to follow present its recommendation for the reinvestment of this fund for greater income.

Mr. Stringham, chairman of the committee on civic design, reported close cooperation during the year with the California Roadside Council.

Birge M. Clark, chairman, told of the efforts of the public information committee to gain recognition of architects in press items and the results that had been attained.

The public relations committee, Henry H. Gutterson, chairman, was reported to have been actively engaged in a joint committee with the Structural Engineers to study present laws hindering architects and engineers from employment on State work.

Harris C. Allen, chairman of the large scale housing committee, told of its participation in conferences with public officials and others in connection with the establishing of housing authorities for the control of large scale housing projects in this area.

Wm. Wilson Wurster, chairman of the exhibit committee, spoke for his group. Little was said of the past architectural exhibit because it had been reported at earlier meetings. Instead he told of the opportunity offered by the Exposition Company to show the exhibit at Treasure Island, with the cooperation of the San Francisco Architectural Club.

His motion was unanimously carried, calling for immediate cooperation with the parties having this matter in hand.

Ernest Weihe, Institute representative on competitions, reported having conferred with several material firms and magazines with respect to projected competitions.

Under new business, plans were discussed and approved for a joint meeting with the State Association to be held at Treasure Island on Tuesday, February 28th.

The final business of moment was the election of officers for the ensuing year. The following were duly elected: President, James H. Mitchell; Vice-President, Wm. Wilson Wurster; Secretary-Treasurer, John Davis Young; Directors, Warren C. Perry, Ernest E. Weihe, Charles F. Masten, Chester H. Miller.

It was the instruction of the meeting that the newly elected directors arrange among themselves for the rotation of their terms in accordance with the provisions of the By-Laws.

With the new president presiding, the final action of the meeting before adjournment was the unanimous passage of Mr. Weihe's motion, expressing appreciation to the retiring president and officers for their loyal efforts and accomplishment.—J.H.M.

MODERNIZED PRODUCTS

Brief Notes on New Materials and Equipment in the Building Industry.

165. ABOUT HARDWOOD

E. L. Bruce Company have another of those little booklet - magazines, "Bruce Every Month," for the first month of the new year. Send for your copy by clipping the coupon below.

166. LAMINEX DOORS

Doors of "Woco" Laminex is the title of a very interesting brochure issued by the Wheeler-Osgood Sales Corporation. Some striking designs in doorways and description of this new product used in their manufacturing are included in this brochure.

167. METAL LATH

From the Metal Lath Manufacturers Association has come a new booklet, "Metal Lath News." Herein is contained much information concerning the use of and specifications for, metal lath. The coupon will bring a copy.

168. STRUCTURAL STEEL

The American Institution of Steel Construction has issued a small magazine in booklet form called "The Steel Constructor." The January number contains interesting photographs of several of the larger steel jobs throughout the country.

169. USES OF CEMENT

A very fine booklet to illustrate the various types of cement manufactured by the Santa Cruz Portland Cement Company has just been brought out. It is one of the most interesting booklets in quite some time. Send for your copy by clipping the coupon.

170. PLUMBING FIXTURES

Again we have with us that inimitable little magazine, the "Mueller Record." Always a welcome arrival, it contains some very pertinent matter, also a story about the Golden Gate International Exposition.

171. STEEL MANUAL

Another iron and steel booklet; this one issued by the American Iron and Steel Institute is entitled "Steel Products Manual" and contains information relative to rolled steel structural sections.

172. USES OF LEAD

"Lead," the booklet put out by Lead Industries Association, as usual has some excellent data on the uses of lead in the building industry. Send for a copy.

173. TOUGH FLOORS

"Smooth, tough floors save money," is the title of a broadside just received from the Flexrock Company. How and why is told in an interesting manner.

174. NEW PRODUCT

The Westinghouse Company have issued a two-page broadside illustrating Micarta with colored panels to show the various shades in which it may be had. Send for a copy by using the coupon.

175. COLORMIX CONCRETE

The new colormix concrete floor is pictured in a broadside put out by the Master Builders Company. These floors are finished with "Kurokrome" and the company states that this gives resistance to heavy wear.

176. GAS REFRIGERATION

The Clow Gas Steam Heating Company, through its San Francisco office, have issued an illustrated booklet on Servel Electrolux Refrigeration. Many questions concerning gas refrigeration are answered with text and illustration.

177. REFLECTORS

Some time has elapsed since we have had a new copy of "Parmalector News." Pittsburgh Reflector Company, however, has just put out a new issue which is obtainable by sending for a copy.

178. QUALITY PLYWOOD

A very handsome little booklet has been received from the Resinous Products and Chemical Company, illustrating the uses of "Tego" Bonded Products, resinous and related materials in building construction. This company manufactures Tego Resin Film and Uformite, a quality plywood.

179. KEEPS COST DOWN

The Brown Instrument Company publishes an interesting broadside on the cost-saving by use of proper instruments. Various types of panels, switchboards, etc., are illustrated. A copy will be sent by using the coupon.

FREE FOR THE ASKING

Check items on coupon, paste on letter head or postal card, and mail to Architect and Engineer.

Architect and Engineer
68 Post Street
San Francisco, Calif.

Please send me literature on the following items as checked below. This request places me under no obligation.

- | | |
|------------------------------|------------------------------|
| 165 <input type="checkbox"/> | 172 <input type="checkbox"/> |
| 166 <input type="checkbox"/> | 173 <input type="checkbox"/> |
| 167 <input type="checkbox"/> | 174 <input type="checkbox"/> |
| 168 <input type="checkbox"/> | 175 <input type="checkbox"/> |
| 169 <input type="checkbox"/> | 176 <input type="checkbox"/> |
| 170 <input type="checkbox"/> | 177 <input type="checkbox"/> |
| 171 <input type="checkbox"/> | 178 <input type="checkbox"/> |
| | 179 <input type="checkbox"/> |

My Name _____

Name of Company _____

Street _____

City _____ State _____

JOHNSON

Since 1904

Pioneers in the manufacture of Oil Burners for every need of Home and Industry.

Let us help you solve your problem of heating and ventilating.

Worthwhile territories and Johnson franchises available



S. T. JOHNSON CO.

940 Arlington, Oakland, Calif.
401 N. Broad St.
Philadelphia, Pa.



SELECTAIR

● Compact, dependable, this split system air-conditioning unit offers every desired feature for economical heating, air-conditioning and ventilating the home. With year 'round domestic hot water. Oil-fired by the Johnson Pressure Type "Bankheat" Burner.



For GAS HEAT choose the DELCO CONDITIONAIR

Built and Backed by General Motors

● This extremely efficient unit automatically warms, purifies, humidifies and circulates the air—supplies complete winter air conditioning to which summer cooling can easily be added. A quality product of unusual efficiency with the plus value of the "General Motors" name. Also models for oil heat. Get complete specifications from —

ALADDIN HEATING CORPORATION

Delco-Frigidaire Dealer

2222 SAN PABLO AVENUE • OAKLAND

SOUTHERN CALIFORNIA CHAPTER

S. B. Marston, president of the State Association of California Architects, at a joint meeting of the Association and Southern California Chapter, A.I.A., urged more cooperation in the profession.

The two principal problems this year, according to Mr. Marston, are the accomplishment of proposed changes to State legislation. A bill has been introduced in the Senate calling for amendments to the act regulating the practice of architecture. Under these amendments the organization of the State Board of Architectural Examiners would be changed to a single State board, provisional certificate requirements would be done away with and successful candidates would be granted State certificates immediately upon passing the examination.

Amendments to the State Constitution and the State Contract Act, clarifying civil service provisions, are also proposed. Adoption of these changes would permit State departments to employ private architects on various State building projects. Immediate action on enactment of this legislation was suggested by Earl Heitschmidt, and advantages to the taxpayers in having plans drawn by this method were described by Albert R. Walker.

Edwin Bergstrom, treasurer of the Institute, stated that there is an apparent drift of the practice of architecture from a professional standard to a purely business basis. He read a paper on the "Ideals of the Architect."

Chapter officers for 1939 were installed as follows:

Eugene Weston, Jr., president; Edgar Bissantz, vice-president; Ben H. O'Connor, secretary; Earl T. Heitschmidt, treasurer; Samuel E. Lunden, director of the three-year term; George J. Adams, director of the two-year term, and Robert H. Ainsworth, director of the one-year term.

OREGON CHAPTER, A. I. A.

Following were the minutes of the December meeting of Oregon Chapter, A. I. A., held at Hilaire's restaurant, Portland:

Present: Messrs. Howell, Heiler, Schneider, Aandahl, Morin, Brookman, Belluschi, Jacobberger, M. Fritsch, Barnes, Baer, Kotchik, Schmeer.

Minutes of Joint Session read and approved. Secretary was instructed to inform Legislative Committee relative to the proposal for adequate legislation re: Development of the Columbia Basin.

Howell read letter from Institute relative to certain local students and draftsmen for Mentor system, including Gerald MacGonigle of Oswego, Stuart Mockford and Miss Ebba Wicks of Astoria.

Considerable discussion ensued relative to the precarious financial condition of the O. B. C. As the Chapter feels a moral responsibility for the continued operation of this body, Messrs. Brookman and Doty

were instructed to work together with Mr. Jacobberger's Construction Industry Relations Committee to map out suggestions as to how the Chapter can help reorganize the O. B. C. on a successful basis and to report at the annual meeting.

Mr. Heiler reported for the Nominations Committee as follows:

For President, A. Glenn Stanton;
 Vice President, Pietro Belluschi;
 Secretary, Roi L. Morin;
 Treasurer, Joseph W. Heiler;
 Trustee, L. D. Howell.

Mr. Howell read a letter from James Ford of Harvard University requesting a list of names of architects in this locality who do modern architecture. Prof. Ford is writing a book on "modern" in the United States.

WASHINGTON CHAPTER ELECTS

Following are this year's officers of the Washington State Chapter, A. I. A.: President, Floyd A. Naramore, Seattle; first vice president, William J. Bain, Seattle; second vice president, Nelson J. Morrison, Tacoma; third vice president, Harold C. Whitehouse, Spokane; secretary, Victory N. J. Jones, Seattle; treasurer, Clyde Grainger, Seattle; members of executive board, William J. Bain and B. Marcus Priteca. The annual election was held January 28.

DRAFTSMEN'S EMPLOYMENT BUREAU

The California Society of Architectural Draftsmen announces its recently established up-to-date employment bureau. This file is an active one, maintained by the Society's employment committee, and is accessible at the State Association offices, 557 Market Street, San Francisco. Herein all the experience, the sources of this experience, and all qualifications of the members are kept systematically.

This feature provides a great saving of time for the architect, inasmuch as he can obtain all necessary information beforehand, without lengthy interviews.

Several calls have been answered, and the positions filled. Architects in need of additional men will find it to their advantage to make use of this bureau.

LANDSCAPE ARCHITECT

Butler Sturtevant of San Francisco did the landscape work for the H. L. Adams house, illustrated in the December Architect and Engineer. Henry H. Gutterson was the architect.

STATE LICENSE

Harry S. Broman, architectural draftsman in the office of Edwin J. Ivey, Inc., 1314 E. John Street, Seattle, recently was issued a Washington state license to practice his profession. Mr. Broman is a graduate of the School of Architecture, U. of W., class of 1935.

It's Ready for You... **THE NEW DOOR CATALOG**



ISSUED BY THE MANUFACTURERS OF
The Country's Most Complete Line of Doors

Everyone concerned with planning, specifying or building—residences, garages, or commercial structures—should have this valuable, new catalog for immediate reference.

Contains over 200 designs and layouts—gives complete information for solving virtually every interior and exterior door problem—provides helpful facts about various types of doors.

WRITE FOR YOUR FREE COPY NOW

Tell us where to send your copy—there is no obligation. Included in SWEET'S ARCHITECTURAL CATALOG for '39.

WHEELER OSGOOD SALES CORPORATION
 Manufacturers of Laminex Products

Factory: Tacoma, Washington
 General Sales Offices: 122 S. Michigan Ave., Chicago, Ill., Dept. C
 New York • San Francisco • Los Angeles • Dallas • Wichita • Tacoma

**Pressure
 Treated Lumber?**

Specify

BAXCO CZC

**"Chromated Zinc
 Chloride"**

**Protects against decay
 and termite attack**

•
*Available for prompt shipment
 throughout California*

•
J. H. BAXTER & CO.

601 W. 5th Street
 LOS ANGELES
 Phone Michigan 6294

333 Montgomery Street
 SAN FRANCISCO
 Phone DOuglas 3883

"The Nation's Schoolhouse Window"

DALMO Simplex Fixtures

Efficient Plumbing

KRAMER Flush Valves

Supreme Light Control

ALUMILITE Venetian Blinds

MacDONALD 
HARDWARE MANUFACTURING CO.

YUkon 0123

963 Harrison St.

San Francisco

"Goods of the Woods"

Dependable Building Materials

Lumber and Millwork

for

All Types of Construction

★

**Wolmanized or Creosoted
Lumber and Timbers
is your protection against
Termites and Decay**

★

E. K. WOOD LUMBER CO.

San Francisco

Los Angeles

Oakland

SUPER-HARBORD FOR SUPER CONSTRUCTION

Super-Harbord, used extensively for exterior covering at the Golden Gate International Exposition, is the outdoor plywood manufactured by Harbor Plywood Corporation, Hoquiam, Washington. California distributors are the Maris Plywood Corporation, San Francisco, and George E. Ream Co., Los Angeles.

Super-Harbord plywood is hot-pressed with a cresol formaldehyde synthetic resin binder, insoluble in water, fusing the plies together as solidly as a single board, and guaranteed against ply separation. The binder is toxic to termites, insects and rodents. It has also the workability of wood plus the size and convenience of large panels, and is impervious to moisture and weathering.

Super-Harbord plywood panels are available in panels as large as 8 x 16 feet, in Douglas fir or redwood; Super-Harbord Plycrete for concrete forms; and the Super-Harbord siding Harborside.

Harborside offers distinctive advantages for residence and commercial building exteriors, including large panels for modern design and labor economies, swell-proof shrink-proof construction, lengthening of paint life through moisture barriers within the plywood. Harborside may be specified in redwood or fir face (there is only one grade, free from face defects to require special shelling or painting). Panels are double rabbeted at sides and ends: four feet and eight feet by 12½, 15, 18 or 23 inches, grain vertical or horizontal. Lays up with edges lapped, with edge joints flush (for restication moulds) or edges eased and laid up flush to form a slight "V" joint restication line.

Harborside delivered to the job clean and dry, in bundles convenient for handling, and ready to apply. Informative but Harborside is available upon request.

EDWARD LANGLEY SCHOLARSHIPS

The last day for filing proposals for the Edward Langley Scholarships, 1939, is March 1 with the secretary of the American Institute of Architects, 1741 New York Avenue, Washington, D. C.

Awards will be announced about June 1 to residents of the United States and Canada.

These scholarships are awarded annually for advanced work in architecture, for study, travel, or research, as the holder of the scholarship elects. Awards to undergraduates are precluded, but may be made to architectural draftsmen who desire to do undergraduate work or take special courses in architectural schools. An award in a succeeding year to a holder of a scholarship is not precluded.

The scholarships are open to all persons engaged in the profession of architecture.

ANSWERS TO MEMORY QUIZ

On page 9.

First question, correct answer is firm name numbered (2); second, (1); third, (2); fourth, (1); fifth, (1); sixth, (1); seventh, (3); eighth, (2); ninth, (1).



DISPLAY OF S. T. JOHNSON CO. AT THE OAKLAND NATIONAL HOME SHOW. THE "SELECTAIR" AIR CONDITIONING UNIT IS ON THE RIGHT; THE "FINNEGAN" IN THE REAR CENTER AND THE NEW AQUALUX BOILER-BURNER UNIT AT THE LEFT

UNIQUE EXHIBIT OF OIL-HEATING EQUIPMENT

ADVANCED types of heating and ventilating devices and the comforts of oil-heating equipment, were displayed and explained by the S. T. Johnson Co. at the National Home Show held last month in Oakland.

"Off again, on again Finnegan" provided an attraction every day for the crowds. This demonstrated the perfect combustion and control of a powerful oil-burner, operating in the open air at one-minute intervals.

George Harrison, chief engineer of the Johnson factory, designed the spectacular "Finnegan" burner for the exhibit. Employing a Minneapolis Honeywell regulator and the standard Johnson Bankheat oil burner, the hot flame leaped out every sixty seconds within a protecting screen but clearly demonstrating the quick heating possibilities of the Johnson burner.

Another feature of the Johnson exhibit was the new Aqualux water heater with full automatic operation, producing domestic hot water and heat with thermostat or finger-tip control.

"The 'Finnegan' brought 'show me' sales methods to the Johnson exhibit at the Oakland Home Show," declared J. C. Johnson, president of the concern. "Com-

plete safety and dependability through the use of cheap fuel oil was brought home by this novel display. The operation of the 'Finnegan' in the nine days of the show equaled a normal five-years' operation in the home.

The S. T. Johnson Company, pioneers in the development of light and heavy duty automatic oil burning appliances and air-conditioners, have just signed up for large display space at the International Air Conditioning Exposition to be held in Cleveland, Ohio, in January of next year. The Johnson burners will also be shown this spring at the New York Power Show and all national conventions and displays of the Oil Burner Institute.

COMPETITION OF INTERIOR DECORATORS

A competition for students of interior decoration to design the interior furnishings of a country dining room, along modern lines, is announced by James Blauvelt & Associates, of New York City. Particulars including program may be obtained by addressing the above firm at 38 East 57th street, New York City. The competition closes May 1.

Worth Looking Into

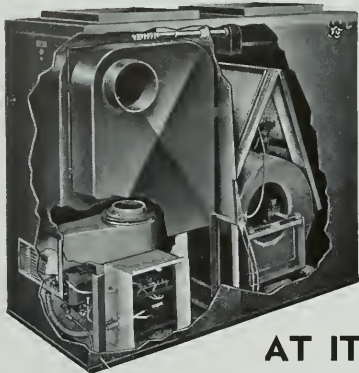

**OIL
HEAT**

AT ITS BEST

RAPID, UNIFORM WARM AIR CIRCULATION throughout entire house . . . quiet, rubber-mounted Motor Driven Multi-vane Blower Unit.

CLEAN, FILTERED AIR, four large spun glass air filters . . . humidified. **H. C. LITTLE FULL AUTOMATIC, FULL ELECTRIC IGNITION OIL BURNER** . . . constant controlled temperature, burns low priced furnace oil.

For all-around comfort and economy . . . match with H. C. Little Oil Burning Water Heater.

H·C·LITTLE BURNER CO.

Factory: San Rafael, Calif.

Dealers Everywhere

Equipped with Corrosiron Fan



Life Science Building, University of California, Berkeley

Federal, State and Municipal Architects Specify

—CORROSION—

fans, ducts, drain pipes and fittings because they are acid-resisting

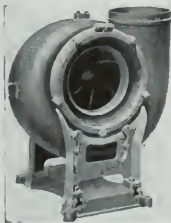

Corrosiron Fan

Architects and Mechanical Engineers

write for suggested specification form to

Pacific Foundry Co., Ltd.

New York

Los Angeles

3100 Nineteenth Street, San Francisco, Calif.

SCULPTURE AT THE FAIR

(Concluded from Page 41)

Around the tower, boldly arched pavilions lead into the main exhibit structures. In each of these four pavilions is a single piece of statuary by Malmquist, Pucinelli, Cadornin and Taliabue. Over the two main arches leading into the court are two applied figures by Adeline Kent, representing Air and Water.

Man's conquest of the oceans of the world is expressed by the architecture, sculpture and painting of the Court of the Seven Seas. Designed originally by George W. Kelham, and carried to completion after his death by J. H. Clark, it is the longest and one of the most beautiful courts of the Exposition. Almost a thousand feet long and two hundred feet wide it extends from the Court of the Pacific to the central Court of Honor.

In the Court of the Seven Seas rhythm of tremendous scale is obtained by the equal spacing of sixteen sixty-foot pylons along its sides. Crowning these pylons are perched the prows of galleons, each graced with a winged figure representing the Spirit of Adventure, the work of P. O. Tognelli. Haig Patigian's "Creation" is also in this court.

High up on the walls, between these major motifs, are spaced a trilogy of sculptural panels by Tognelli depicting "Exploration," "Trade" and "Commerce."

Six ten-foot panels over the six minor east entrance doors to the Hall of Electricity facing this court were painted by John F. Stoll.

At the northern terminus of the Fair's main axis is the Court of Pacifica. The west wall of this court carries a gigantic mural built of plaster, metals, enamels and glass. The mural is by Margaret, Helen and Esther Brunton, and it is virtually the "Theme piece" of the Exposition, emphasizing the Fair's underlying motif, Pacific peace and unity. The great panel is called the "Peacemakers."

The two large scale central figures stand for the peaceful ideas of the East and the West, while the friezes of figures moving toward them symbolizes the slow march of mankind toward these ideas.

One of the loveliest fountains of the Exposition is to the east of the Western Gateway, the entrance opposite the main ferry terminal. This fountain, operated by three pumps, has a capacity of 92,000 gallons of water.

Surrounding the sunken basin of this fountain, and on the fountain itself, are pieces of sculpture fashioned by such artists as Jacques Schnier, whose male and female statues symbolize the spirit of India; Brents Carlton, with a Polynesian group; Sargent Johnson's Inca Indians; Carl George's figures of North American Indian and modern women; the statues of Adaline Kent which are symbolical of the Islands of the Pacific; a North American group by Ruth C. Wakefield; a South American group by Cecilia Graham, and a Chinese group by Helen Phillips.

Southward from the Court of Honor, the Court of the Moon opens out to disclose a series of gardens and pools. At night the resources of artificial "moonlight" will enhance the charm of this court and its beautiful landscaping. Here we find a very lovely fountain, rectangular in shape and sufficiently large to accommodate twenty-four arches of water, by Ettore Cadornin.

To the south of the Court of the Moon are the Enchanted Gardens with their great pool and fountain with a capacity of 406,000 gallons of water. Around this fountain will be grouped the works of Haig Patigian which are called "The Earth Dormant," "Sunshine," "Rain," "Fruition" and "Creation." Ettore Cadornin's "Moon and the Dawn" is on the east-west axis.

On the walls of the two South Towers flanking these gardens are several fine murals by Helen Forbes. Dorothy Pucinelli decorated the two walls of the tower.

In the westerly tower, the entrance to the Mining Palace, Franz W. Borgmann did two murals of like size. One of them "Gold," represents three miners digging, with a symbolic figure in the center. The other is called "Fortuna" and represents a

miner and a lady of the '90's with the symbolic figure of fortune in the center. Two other oils are by Nelson Poole.

Directly east from the main court is the Court of Reflections. Here the spirit of peace and tranquility prevails. Edgar Walter's exquisite "Penguin Girl."

Over the entrances leading into this court are the two bas-relief figures by David Slivka, "Abundance," and "Fertility." Four relief panels by Michael von Meyer representing "Beauty," "Knowledge," "Music" and "Labor" grace the walls.

Leading from this court into the Court of Flowers is the magnificent Arch of Triumph. For the west face of this arch Jacques Schnier has done two stylized eagles representing the United States. Two mural panels on the inside face of the arch, each 10 feet wide and 44 feet high, were done by Hugo Balin. Two decorative panels on the buttress of the east side of the arch were fashioned by William Gordon Huff.

One of the most colorful areas on Treasure Island will be the Court of the Flowers. Five fountains will be found in this court designed by Lewis P. Hobart. The largest of these rises from a circular basin just beyond the Triumphal Arch.

The dominating piece of sculpture for this fountain was fashioned by O. C. Malmquist, as were the lesser figures around its base. The main figure is that of a woman, which is called "The Rainbow."

Choosing oil for his medium, Millard Sheets has done a trio of panels for the walls of one of the palaces abutting the Court of the Flowers.

A cosmopolitan atmosphere will be found in the Pacific Basin, eastward of the main east-west axis. Here are concentrated the buildings of foreign Pacific governments around the broad lagoons, spanned by bridges to symbolize unity. Structural shapes of these small governmental buildings and groups reproduce native forms. The entrance into the Court of Flowers is marked by temple-towers by Merchant, standing upon ghats and flanked by mural panels. Jacques Schnier has decorated the north wall with a bas-relief representing the "Dance of Life." On the south wall adjoining the towers, Lulu Hawkins Braghetta has done a similar panel called "Darkness."

A horizontal terra cotta relief map was fashioned for the Pacific House by Antonio Sotomayor. This pictorial map, 30 feet wide and 47 feet long, is made in 361 sections, and will constitute the complete map, built on the scale of 4,000 feet to the inch.

Adjoining the Pacific Basin is the Court of the Nation where rises the Federal building. For the walls of this building Frank Imrey and his assistants have painted a mammoth mural showing the development of the U. S. Army.

On the Western States Building nearby, Robert B. Howard has in relief the Amenities of Western Life and the Economic Development of the West. For the entrance to the Aviation Palace, Carlo Taliabue symbolizes the Spirit of Aerial Transportation. On the wall between the South Tower, Jacques Schnier portrays the spirit of goodwill between the East and the West.

PARAFFINE PROMOTIONS

Several key promotions have recently been announced by R. Hilliard, sales vice-president of the Paraffine Companies, Inc. J. E. Holbrook, of Los Angeles, southern district manager, is transferred to headquarters at San Francisco as assistant general sales manager. W. R. Greig, of San Francisco central district, is transferred to the southern district as manager. L. K. Bishop, paint division manager, is appointed district manager of the central district. L. Greenville, assistant sales manager, becomes manager of the paint department, and G. R. Schumann, assistant manager.

To Each Building You Plan --

A Long Life And a Useful One

Twenty years is a short span in the life of a building.

Yet few buildings put up 20 years ago are considered "fit" according to modern standards unless they have undergone recent rejuvenation.

A check of the buildings erected 15 or 20 years ago will show that almost without exception they have had extensive and expensive rewiring and relighting, or else they are hopelessly out of date in their electrical facilities.

Nothing so ages and dates a building as inadequate wiring and lighting.

The architect today who can refer his clients to buildings he planned 15 or 20 years ago which are still in popular demand because they are giving modern efficient service, is the architect with a high professional standing.

Red Seal specifications furnish a sound minimum basis from which to work. They are free for the asking.

See the electrical exhibits at the Palace of Electricity and Communications at the Golden Gate International Exposition

PACIFIC COAST ELECTRICAL BUREAU

447 SUTTER STREET • SAN FRANCISCO, CALIFORNIA

POMONA TILES

FOR
Bathrooms and Kitchens
in over 60 colors

Warehouses and Display Rooms

135 Tenth St. San Francisco
629-33 North La Brea Ave. Los Angeles
6106 Roosevelt Way Seattle

POMONA TILE MFG. CO.
PLANT — POMONA, CALIF.



Original ORIGINAL contours in the new Lightolier designs promote more interesting interiors as definitely as they provide greater lighting efficiency. Equipment of this type, formerly beyond the reach of the average home owner, is now available at exceptionally low prices. Write for the "Charm of a Well Lighted Home," our new interesting and helpful booklet.

INCANDESCENT SUPPLY CO.
SAN FRANCISCO : OAKLAND : FRESNO : LOS ANGELES



SANTA MARIA INN
Santa Maria, California

ON THE COAST HIGHWAY
between San Francisco and Los Angeles
OVER NIGHT OR JUST A MEAL

FRANK J. MCCOY, *Owner*

GEO. A. THOMPSON, *Manager*

A Permanent Exposition
of the newest ideas
in home planning
and equipment.



THE BUILDING MATERIAL EXHIBIT

Architects Bldg. • Fifth & Figueroa • Los Angeles • MU-6306

OBITUARY

Carl F. Gould, Architect

Carl F. Gould, architect, junior member of the firm of Gould & Bebb, Seattle, Washington, died in a Seattle hospital January 4 after an illness of several months. At his bedside were his wife and daughter, Anne, who had returned a few days previously from Smith College to take over her father's work in the architectural firm of Bebb & Gould.

As the designer of the building plan for the University of Washington and head of its department of architecture from 1914 until 1926, Mr. Gould was one of the best known architects in the country. Associating with Charles H. Bebb in 1914, he designed many outstanding buildings in the Pacific Northwest, including the State Capitol, Olympia, the Olympic hotel, St. Nicholas school, Lakeside school and the Telephone building in Seattle, the Everett general hospital and several buildings of the Western Washington College of Education in Bellingham.

The Seattle Art Museum, which Mr. Gould designed, has been adjudged one of the 100 best buildings constructed in the United States in the last fifty years, and models of it will be represented in an exhibition to tour the United States and Europe under the auspices of the American Federation of Arts.

Mr. Gould was a member of the A.I.A. and a former president of the Washington Chapter, and a member of the Society of Beaux Arts Architects.

Kenneth M. Murchison

Kenneth M. Murchison, distinguished architect of New York and recently made editor of a new publication "Arco-TECT" sponsored by the American Radiator Company, died suddenly the latter part of January.

Kenneth Murchison was a man of such vivid talents that not only his interest but a real understanding extended to so many of the other arts, in which he was highly accomplished. Besides being an outstanding architect he had served as vice president of the Bowery Savings Bank, New York.

For years he was the moving spirit in the Beaux Arts Ball staged by New York architects and his productions made it the outstanding social event in the nation's greatest metropolis.

He was one of the architects who published the now defunct magazine, "The Architect" and his writings were unique in style and good humor.

Arthur O. Johnson

Arthur O. Johnson, architect, passed away in January in an Oakland hospital, following a brief illness. He was a resident of Berkeley at the time of his death but was practicing in San Francisco.

Mr. Johnson for many years was employed in the office of Henry M. Meyers in San Francisco. Later he was associated with Ernest J. Kump in Fresno. He was architect of many school buildings throughout the State

of California. He is survived by a widow and three children.

Chas. I. Carpenter

Charles I. Carpenter, pioneer architect of Spokane, who designed many structures in the Inland Empire, died in December at the Spokane hospital. At the time of his death he was architect for the \$300,000 high school building now under construction at Moscow, Idaho.

LOS ANGELES STRUCTURAL ENGINEERS

Officers for 1939 were elected at the January 4th meeting of the Structural Engineers Association of Southern California, at Hotel Clark, Los Angeles.

The new officers are: John E. Shield, president; Gordon DeSwarte, vice-president; Ben Benioff, secretary; Mark Falk and S. B. Barnes, directors.

The following committees and chairmen were named by President Shield: Program, R. J. Kadow; Legislative, Paul E. Jeffers; Publicity, Theodore C. Coombs; Professional Activities and Welfare, Blake Beatty; Major Disaster, Oliver G. Bowen; Code of Standard Practice, Ralph A. DeLine; Ethics, D. D. Smith.

Interest in the annual reports centered in that of the ethics committee, prepared by Blake Beatty, and read by D. D. Smith; also the report of the legislative committee presented by Mark Falk. Both these reports dealt largely with matters of professional conduct. Mr. Beatty's report covered, generally, the efforts of the committee toward control of ethical abuses ranging from minor matters to those involving actual violations of the State Registration Laws.

The legislative committee's report, after reviewing work done on the re-codification of the Civil Engineers' Registration Laws and a summary of the New Architects' Act and its possible influence on the structural engineers, brought up possible legislation designed to correct many of the more serious ethical offenses; offenses which are permitted under the present laws but are frowned upon by the ethical members of the profession.

ENGINEERS AND ARCHITECTS

The Engineers and Architects Association of Southern California held their regular dinner meeting at the Royal Palms Hotel, 360 South Westlake Avenue, January 26. Lynn Atkinson, a member of the Association and a Los Angeles contractor, spoke on "Overhead and Express Highway System as a Solution to our Traffic and Rapid Transit Problem."

PERSONAL

Messrs. Marsh, Smith and Powell, 516 Architect's Building, Los Angeles, announce that until further notice their offices will be closed Saturdays.

Robert F. Train and Frank R. Schaefer have formed a co-partnership for the practice of architecture, under the name of Train & Schaefer, with offices at Suite 227, 321 W. Third Street, Los Angeles.

INCLUDE TREES IN YOUR PLANS

DAVEY, ORIGINATOR OF TREE SURGERY, OFFERS FREE
INSPECTION AND ESTIMATE.



SAN FRANCISCO Fresno LOS ANGELES
Russ Bldg. Mattei Bldg. Story Bldg.
Sutter 3377 Tucker 1929
Local phones in: Pasadena, Palo Alto,
Oakland, San Rafael, San Mateo

SKILL - KNOWLEDGE - RESPONSIBILITY

U.S.
PRODUCTS

VAN ARSDALE-HARRIS Co.

ENGINEERS & CONTRACTORS

ACOUSTICAL TREATMENT - INSULATION
SOUND CONTROL

FIFTH & BRANNAN STS. SAN FRANCISCO, CALIF.
TELEPHONE GARfield 3600
DIVISION

VAN ARSDALE-HARRIS LUMBER CO., INC.

USE BASALITE

Light-weight, pre-fabricated Con-
crete building products for floors,
walls, and roofs in your next
building.

BASALT ROCK COMPANY, INC.

Napa, California

NOISE CONTROL— ON TREASURE ISLAND

STATE AUDITORIUM AND RADIO STUDIOS
BELL TELEPHONE SYSTEM EXHIBIT
SAN FRANCISCO RECREATION EXHIBIT
FEDERAL BUILDING THEATER

Furnished by—

WESTERN ASBESTOS CO.

Building Materials Mechanical Specialties
SACRAMENTO OAKLAND
SAN FRANCISCO

What will an
AGENCY ACCOUNT
do for me?



Let us answer this question for you by sending you our interesting booklet, *An Introduction to Agency Service*, describing the modern, economical way to handle securities.

Just ask for Booklet M-2

CROCKER FIRST NATIONAL BANK
OF SAN FRANCISCO
California's Oldest National Bank



No longer a problem
for the Architect

TRANSIT MIX CONCRETE
AND MORTAR

makes delivery of material to the job swift and inexpensive . . . minimizing the architect's supervision costs and assuring his client a dependable mix.

Speed . . . Reliability . . . Economy
Let us co-operate with you

Golden Gate-Atlas Materials Co.

16th and Harrison Streets
San Francisco
UNderhill 3650

THE MEN WHO MADE TREASURE ISLAND

[Concluded from Page 21]

tural Division, directed the design of various features completing the architectural composition, such as the lagoons and bridges, the important Western States Building, as well as the picturesque Latin - American Court. The key men mentioned above, with the other members of the Architectural Staff, have ably assisted in all this work.

In the capacity of Chief of Color, J. E. Stanton has designed and directed the architectural color scheme, including planning and directing of the work of the mural painters. As a part of the color scheme, he has coordinated and harmonized the decorative illumination in collaboration with the Division of Electricity and Mr. Dickerson of the General Electric Co.

Harry Vensano, civil engineer, as Chief of Construction, has had the heavy responsibility of directing the actual building operations. John Gould served as Chief Structural Engineer, closely collaborating in the architectural features; Albert Evers was the Chief of the important Division of Specifications; William E. LeLand, Chief of the Division of Mechanical Engineering, collaborating on the fountains and other mechanical features; William R. Van Bokkelen acted as Chief of the Division of Electrical Engineering and directed the illumination installations.

Messrs. Mark Daniels, Thomas Church, Butler Sturtevant, and Miss Bella Worn acted as consultants on the preliminary landscape architectural plans, and the subsequent development of the vast planting scheme was admirably planned, installed and administered by Julius Girod, Chief of the Division of Horticulture.

In carrying its work to completion the Board of Architects followed the construction details closely and during the time the buildings were in the making the Board held frequent meetings to consider questions of plan, design and architectural policy. It coordinated with the general plan, the location of buildings other than the Exposition Company palaces and courts, but the individual buildings

WILLIAM VOLKER CO.

STANDARD SHADE ROLLER
GUARANTEED

LUXOR

IS THE FINEST HAND-MADE
CLOTH

SAN FRANCISCO

631 Howard Street EXbrook 5727

FLOORS

"For Any Purse or Purpose"

Numerous Jobs Installed
in the Exposition

LeROY OLSON COMPANY

*Contractors - Manufacturers
Distributors*

3070 - 17th Street
San Francisco
UNderhill 3838

SISALKRAFT

REG. U. S. PAT. OFF.

*"More than a
building paper"*

THE SISALKRAFT CO.

205 West Wacker Drive
(Canal Station) Chicago, Ill.
55 New Montgomery Street
San Francisco, Calif.

Pacific Manufacturing Company

High Class Interior Finish
Quality Millwork

142 Sansome St. 6820 McKinley Ave.
San Francisco Los Angeles
GARfield 7755 THornwall 4196

1315 Seventh Street, Oakland
GLencourt 7850



CLIENTS will bless you for installing the Wesix "49'er" **ELECTRIC BATHROOM HEATER**. But try it first in your own home. Certain that you will like its forty-nine inches of **INSTANT RADIANT HEAT** and **QUICK CIRCULATING HEAT**, we are offering this smart new heater at **factory cost to architects**, for personal use! Limit one heater per architect. List price \$21.50. Please write on your regular letterhead, to: **1018 WESIX BLDG., SAN FRANCISCO**



**HERRICK
IRON WORKS**

**STRUCTURAL STEEL
REINFORCING STEEL**

18TH AND CAMPBELL STS.
OAKLAND, CALIF.
Phone GLencourt 1767

**FORDERER
CORNICE WORKS**

Manufacturers of

- Hollow Metal Products
- Interior Metal Trim
- Elevator Fronts and Cabs
- Metal Plaster Accessories
- Sanitary Metal Base
- Metal Cabinets
- Flat and Roll Metal Screens
- Commercial Refrigerators

269 POTRERO AVE.
San Francisco, Calif.
HEmlock 4100

were designed by architects retained by the various participants. This arrangement has resulted in an appropriate architectural variety.

LAMINEX GOES TO THE FAIR

The design and construction of exposition buildings entail problems more difficult in many respects than those encountered in regular construction work. The adaptability of All-Weather Laminex Plywood and standard Laminex to the requirements of fair buildings has been proved on innumerable occasions. A current example is the building for the Christian Business Men's Committee of San Francisco Bay region on Treasure Island.

Laminex Plywood was used entirely for both interior and exterior walls. The All-Weather Laminex on the outside of the building was manufactured by the Wheeler Osgood hot-press process and is weather-resistant.

The smooth, hard, improved surface of this Douglas Fir Plywood eliminates the necessity of prime coats. As it is possible to obtain satisfactory results with one coat of paint, when All-Weather Laminex is used, only a single coat was applied to the Christian Business Men's Committee Building. All-Weather Laminex is manufactured by Wheeler Osgood Sales Corporation at their Tacoma, Washington, factory.

HEATING ENGINEERS MEET

The American Society of Heating and Ventilating Engineers concluded its 45th annual meeting at Pittsburgh, Pa., January 26th, stressing progress in scientific research in heating, ventilating and air conditioning in observance of the twentieth anniversary of the founding of the society's research laboratory. Under headings dealing with physiological and medical aspects, application of air conditioning to building construction, the testing and rating of equipment by scientific standards to measure performance characteristics and the practical application of solid fuels to heating problems of the average home owner, many subjects were discussed by experts in different fields. In all some twenty technical papers were presented.

Pitcher

**Improved
Disappearing Doors
Save 20% Space**

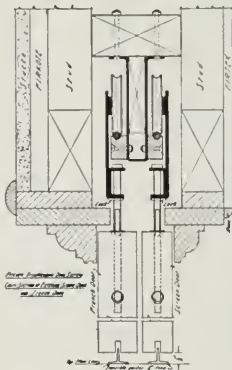

Joins with a 3 1/2" stud wall . . . steel studs . . . adjustable steel and wood track. Can be used for screen doors in connection with French doors. Send for detail drawing.

E. C. Pitcher Co.
461 Market Street
San Francisco

**Donovan Automatic
Awning Type
Windows**

Give 100% natural ventilation
and day-lighting control

**UNIVERSAL WINDOW
COMPANY**
Berkeley, California

**"AMERICAN MARSH"
Redi-Vac Vacuum
Heating Pump**

Send for
Bulletin 441

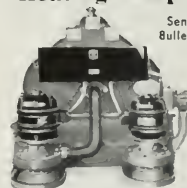

SIMONDS MACHINERY CO.
San Francisco 816 Folsom St. Los Angeles 455 East Fourth St.

*Southern California
Architecture in
Architect and Engineer
for March*

Paul Hunter, Guest Editor

Some of the latest outstanding examples of public and commercial, as well as residence work, by Los Angeles architects, will be featured in the March number of The Architect and Engineer. An issue of exceptional merit and interest.

Start your subscription

Now

The Architect and Engineer

68 Post Street
San Francisco

**Independent
Iron Works**

Structural Steel
Ornamental Iron
Steel Service Stations
Steel Tanks
Standard Steel Mill Buildings
Bridges

821 Pine Street

Oakland

**Clinton
Construction Co.
of California**

*General
Contractors*

923 Folsom Street
San Francisco
SUtter 3440

Prof. Frank B. Rowley, director of the engineering experiment station of the University of Minnesota, was awarded the American Society of Heating and Ventilating Engineer's medal "for distinguished scientific achievement in heating, ventilating and air conditioning."

The award to Prof. Rowley was for his outstanding work as teacher and research investigator in the field of heat transmission, insulation, the effect of moisture condensation on building materials and dust elimination. He is the author of more than sixty scientific papers and reports on these and related subjects.

WESTERN PINE MODEL HOME

Nestled between the large Golden Gate International Exposition buildings and near the huge hangar which houses the aviation exhibit on Treasure Island, stands a pure white Cape Cod Colonial home with striking blue shutters as the Western Pine Association's contribution to the exhibit of Western products at the Exposition. This five-room house, known as the "Western Pine Home," is located on Lot 9-J, and occupies an area 65 feet by 125 feet, adjoining the Homes and Gardens Building at the south end of the Exposition grounds. The design is the work of the well-known Boston architect, Royal Barry Wills, who is one of a group of nationally-known architects that prepared traditional and modern house designs for Life magazine recently.

The lumber and architectural woodwork throughout the Western Pine Home are of Idaho white pine, Ponderosa pine and sugar pine. Wide bevel siding, shutters, doors of varying Colonial styles, paneling—both clear and knotty pine, and special detailed millwork, are some of the items exhibited in finished form in harmonious colors.

All foundation timbers, as well as sash, frames and screens, were treated at low cost with Permatol; Certigrade Red Cedar shingles were used on the roof; and such other important items as sheet lead flashings and white lead paint were provided to insure a first class job. C. E. L. Measure, of the Western Pine Association, is in charge of the exhibit.

ANSWERS FRANK LLOYD WRIGHT

The pointed criticisms of St. Louis buildings expressed by Frank Lloyd Wright, noted American architect, on his recent visit to that city, were dismissed as just "clever phrases" by Benedict Farrar, president of the St. Louis Chapter of the American Institute of Architects, in a recent radio talk.

Farrar said that "Wright is a brilliant conversationalist and speaker, and many of his statements are to be taken as clever phrases rather than his real opinion."

COMFORT

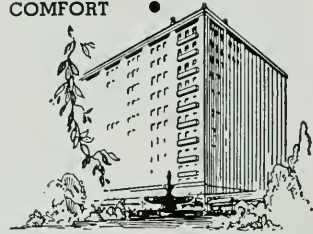

New **HOTEL
CLARK**
in Downtown
LOS ANGELES

Convenience is another offering of this hotel. Whether on business or pleasure bent, the Hotel Clark makes an ideal "base of operations," as well as a restful "billet," at the end of the day's "campaign." Good Food, naturally. And moderate charges, as well as for room accommodations, give final significance to assuring word — COMFORT

Single from \$2.50
Double from \$3.50

ROOMS
555
BATHS

Fifth and Hill

P. G. B. MORRIS, Manager

**ANDERSON
&
RINGROSE**

General Contractors

320 Market Street, San Francisco
Phone GARfield 2245

**HIGH GRADE MILLWORK
AND INTERIOR FINISH
SASH AND DOORS**

**LANNOM BROS.
MFG. CO.**

FIFTH AND MAGNOLIA STREETS
OAKLAND, CALIFORNIA
Telephone: TEmplebar 3663

MULLEN MFG. COMPANY

BANK, STORE AND OFFICE
FIXTURES—CABINET WORK
OF GUARANTEED QUALITY
CHURCH SEATING

Office and Factory:
60-80 RAUSCH ST., Bet. 7th and 8th Sts.
San Francisco
Telephone UNDERhill 5815

G. P. W. JENSEN & SON

Building Construction

320 Market Street, San Francisco
Phone: GARfield 2444

DINWIDDIE CONSTRUCTION COMPANY • BUILDERS •

CROCKER BUILDING
SAN FRANCISCO

Carl T. Doell Co.

*Plumbing
Heating*

Plumbing Contractor
Veterans Memorial Building
Oakland

467 21ST STREET
OAKLAND

Telephone GLencourt 8246

He has made a very substantial contribution to architecture and undoubtedly will be recognized by future historians in the field as one of the real figures of this century. But when he implies, as he did in St. Louis, that no other architect's buildings compare with his own, I think he's just pulling our leg.

When Wright sets up his conception of the ideal as a standard for measuring existing buildings, he's judging by a standard that is very hard to achieve in reality. There are practical problems that every architect faces almost constantly in his work—the handicap of having only a certain amount of money available, and only a certain amount of land, and being forced to accomplish results within that budget and within that space.

On a practical basis, we have to say that a good building is one that represents the best possible structure for the purpose that could have been built under the conditions with the funds that were available. We can't judge the building by what could have been done with unlimited space and unlimited resources.

After all, this isn't just a matter of external appearance. In the first place, buildings have to work—a courthouse has to be a place where court can be held and an auditorium has to be a place where people can meet for conventions and to hear symphony concerts. The external appearance is very important, for the beauty of the building and the beauty of the city; but it's the inside that makes the building a success or a failure."

GARAGE AND OIL STATION

Dear Editor:

I have a small tract of land on U. S. Highway 50 just west of Kansas City on which I plan to build a small commercial repair garage together with oil station facilities for lubrication and retail of petroleum products. The property is adjacent to highly developed residential sections and I want to find a design that will not clash with the neighborhood. I feel that especially at this location it must be architecturally correct.

I wish to find information on service station developments, architecture and construction details.

Will you please advise whether any issues of your journal have covered that subject and if I can obtain the issues and the price. I would appreciate any suggestions you might have as to where best to obtain information along that line.

Also, if it would not be asking too much, would it be possible for you to advise me of firms handling overhead doors, metal sash, etc. I have necessarily got to do most of the work myself and I do not know just where to buy some of the material and obtain design details, etc.

Thanking you very much for your kindness,
I am, Yours very truly,
3243 Sansom St. J. C. DONALDSON.
Philadelphia, Pa., Jan. 17, 1939.

Louis C. Dunn, Inc.

GENERAL
CONTRACTORS

Monadnock Building
San Francisco

Phone: DOuglas 4632

Empire Construction Co., Ltd.

Builders



RUSS BUILDING
SAN FRANCISCO
SUtter 2989

Smith

Lumber Company

WHOLESALE - JOBBING - RETAIL
FACTORY AND BUILDING LUMBER
PLYWOODS - ROOFING

DISTRIBUTING YARDS

San Francisco | Oakland
• | 19th Ave. &
4th & Channel | Estuary
MARket 0103 | FRuitvale 3174

YOUR INQUIRIES SOLICITED

JOSEPH MUSTO SONS-KEENAN COMPANY

MARBLE
and
ONYX

535 NORTH POINT STREET
SAN FRANCISCO
1801 S. SOTO STREET
LOS ANGELES

ABBOT A. HANKS, INC.
Engineers & Chemists

INSPECTING — TESTING — CONSULTING
 CONCRETE • STEEL • MATERIALS
 CHEMICAL AND TESTING
 LABORATORIES
 • RESEARCH AND INVESTIGATION •

TESTS OF STRUCTURAL MATERIALS
 DESIGN OF CONCRETE MIXES
 SHOP AND ERECTION INSPECTION OF
 STRUCTURES AND EQUIPMENT
 INVESTIGATION OF STRUCTURES
 AND MATERIALS
 TESTS AND INVESTIGATION OF
 FOUNDATION SOILS
 FIRE RESISTANCE AND INSULATION
 TESTS

624 Sacramento Street, San Francisco

Phone GARfield 1164

Hunter & Hudson

Consulting Engineers
 DESIGNERS OF HEATING
 AIR CONDITIONING
 VENTILATING AND WIRING
 SYSTEMS, MECHANICAL
 AND ELECTRICAL EQUIP-
 MENT OF BUILDINGS

41 SUTTER STREET
 ROOM 710
 San Francisco California

DUN - PRIME

A Priming Paint
 that makes satisfactory
 2 Coat Work
 possible on Redwood

Specify

DUN-PRIME

and notice the improved appearance
 of your two coat jobs.

White - Ivory - Red - Gray

FRANK W. DUNNE CO.
 41st and Linden Sts. Oakland, Cal.
 MAKERS OF GOOD PAINT

VAUGHN - G. E. WITT Co.

Manufacturers and Distributors

Pump Governors	Oil Heaters
Safety Pump Governors	Relief Valves
Automatic Gas Regu- lating Valves	Oil Burner Governors
Gas Burning Equipment	Oil Burners
Vacuum Pump Governors	Oil Pumping Sets
Vacuum Regulating Valves	Oil Valves
Continuous Flow Steam Traps	Oil and Steam Strainers
Thermostats	Duplex Oil Pumps
Reducing Valves	Rotary Oil Pumps
	Boiler Feed Pumps
	Water Heaters
	Boiler Feed-Water Regulators

4224-28 Hollis St., Emeryville, Oakland

**THE
 HERMANN SAFE CO.**

MANUFACTURERS AND DEALERS
 OF
 FIRE AND BURGLAR PROOF
 SAFES AND VAULTS, SAFE-
 DEPOSIT BOXES, ETC.

200 HOWARD STREET
 SAN FRANCISCO
 GARfield 3041 - 3042

**REPUBLIC STEEL
 CORPORATION**



Manufacturers of

ENDURO Stainless Steel; TON-
 CAN Copper Molybdenum Iron
 Sheets and Pipe; and Steel Pipe,
 Sheets and Reinforcing Bar for
 every building purpose.

Write for information

Rialto Building, San Francisco, Calif.
 Edison Building, Los Angeles, Calif.
 White-Henry-Stuart Bldg., Seattle, Wash.

**VERMONT
 MARBLE
 COMPANY**

Producers and Finishers
 of
 Domestic and Imported
 Marbles

San Francisco
 Los Angeles
 and
 Tacoma, Wash.

Robert W. Hunt Company
 ENGINEERS

Inspection - Tests - Consultation
 Schools and Other Structures
 Are Built as Designed

*When Construction Materials are
 Inspected at point of Manufacture
 and during Erection by*

ROBERT W. HUNT COMPANY

*Cement, Concrete, Chemical, Metallurgical,
 X-Ray and Physical Laboratories*

Chicago - New York - Pittsburgh
 Los Angeles - All Large Cities
 San Francisco, 251 Kearny Street

**JOHN
 CASSARETTO**

—Since 1886—And Still Active—

Building Materials

READY MIX CONCRETE
 ROCK - SAND - GRAVEL - LIME
 CEMENT - PLASTER - MORTAR
 METAL LATH - WOOD LATH
 STUCCO - WIRE NETTING

Service Unexcelled

Bunkers
 Sixth and Channel, San Francisco
 Phones: GARfield 3176, GARfield 3177



MERCURY PRESS

We Print
 The ARCHITECT and
 ENGINEER

*"A Thing of Beauty
 Is a Joy Forever"*

942 HOWARD STREET
 SAN FRANCISCO

**FINE WATER COLORS
 AND PAPERS
 FOR ARCHITECTURAL
 RENDERINGS**

**H. S. CROCKER
 COMPANY, Inc.**

720 MISSION STREET
 MARKET STREET AT SECOND
 SAN FRANCISCO

**THE TORMEY
 COMPANY**

**GENERAL PAINTERS
 AND DECORATORS**

Phone UNDERhill 1913

563 FULTON STREET
 San Francisco



ARCHITECT AND ENGINEER



MARCH 1939

LOS ANGELES HONOR AWARDS



How **24** HOUR SPEED **24** SAVED CROPS!



*Last Chance Water Ditch Head-
 gate (Two Miles from Laton,
 California)*

Engineer: H. H. Holley, Visalia

*Contractor: Jourdan Concrete Pipe
 Company, Fresno*

*Required 1600 sacks Golden Gate
 Cement.*

1938 spring floods brought the waters of Kings River to the highest crest in 60 years. The old headgate of Last Chance Ditch gave way. A crumbling dirt dam was holding back the flood, with five pumps constantly removing seepage water. ★ A new headgate had to be constructed — fast! With the work still endangered by seepage from river and canal, Golden Gate 24-Hour Cement was poured into waiting forms . . . and in a few hours the danger was past. ★ Golden Gate 24-Hour Cement, manufactured by the Double-Burning process, produces a quick-hardening concrete of highest ultimate strength. When you want safety and permanence — with SPEED — make certain . . . specify Golden Gate 24-Hour Cement.

Ask Your Building Materials Dealer

POUR TODAY — USE TOMORROW

PACIFIC PORTLAND CEMENT COMPANY

San Francisco
 Los Angeles

COASTWIDE SERVICE

Portland
 Seattle

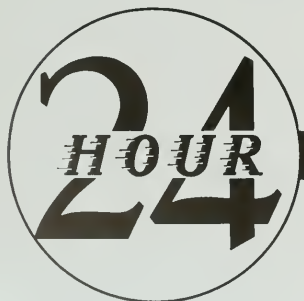

RUNNING FIRE

by
MARK DANIELS, A.I.A.

The Mud Slingers

Hurling mud is not confined to political campaigns. What the politicians may know about the sport, they learned from that ever-present group who, on failing to gather in the rewards of the labor of others, resort to criticism of the work they were either too lazy or unable to do themselves.

The period of gestation for this sort of Minerva, to spring full-fledged, is about two weeks, a shorter time than it takes their Christmas jewelry to turn green. They are now rising from their padded chairs to throw the mud of past inaction at the Exposition and the accomplishment of its officers and architects.

The walls are too high; they are too low. There is too much color; there is not enough color. The exhibits are lousy. "I told them the plaster would fall off." The carillon is out of tune (usually from the deaf). The murals are rotten (from those who think mural is a girl's name). "Now, the idea I fought hard for was . . ." This, and more, from the army who did not lift a hand to help in the work of building what, in the opinion of many who are qualified to judge, is one of the most beautiful Expositions ever developed. About the only complaint omitted, so far, is that there is too much salt in the waters of the bay and I am waiting to hear that.

It is difficult to be patient with these carping, postnatal critics, but we must try, for, like the poor, we shall have them with us always.

* * *

Over-Advertised

The Key Route ferries that ply between San Francisco and Treasure Island keep their loud-speakers hot informing the public that the Elephant Trains will take them anywhere and everywhere. It is good publicity, but becomes monotonous to those who must go to the Island once or twice daily. Another feature that is emphasized is the cocktail bar on the boat.

Returning, one afternoon, I saw a man whom I had recognized as the only patron of the bar a few hours earlier, weaving his way back and forth between the outer deck

and the bar. He would listen to the harangue about the Elephant Trains and then meander to the bar for another drink. He seemed happy and amused.

On landing, he rambled over the gang plank and finally stood teetering from heel to toe, on the curbstone in front of the Ferry Building. Several cars made the loop as he swayed gently, like the mast of a boat at anchor, while he peered this way and that. Finally, addressing no one in particular, he cried, "Well, bring on your Elephant train."

* * *

Dilemma

Classification of exhibits has been one of the most perplexing problems at the Exposition. Should agricultural products be allowed in the floricultural building or vice versa? Where do porcelains belong and a multitude of similar questions.

The latest puzzle is, whether Wrigley's gum should be displayed with Foods and Beverages or Rubber Products. Perhaps it should be classed with Sports and Athletics.

* * *

Corner Conversations

The other day, during one of those pleasant San Francisco rains, I, among others, was cautiously standing under a canopy on Market Street. People rushed by looking for shelter, women with umbrellas tried to stab the more helpless in their right eyes.

Two cute young things in collophane raincoats came rushing by, saw a space of about six inches between my back and the protuberant stomach of another rain dodger. They squeezed in, pushing the front half of me into a steady shower from the canopy above. "Gee, Martha," said one, "ain't this weather awful?"

"Yeah," said Martha, "I hate these cold and wet and sultry days." I left—it was too sultry.

* * *

A la Pegler

Of all the lumbering, slobbering, bellowing, sprawling, spuming, slimy, sloppy oceans, that Pacific is the biggest slob in the World's family of oceans. Why can't it let those pretty little Atolls grow up? Why doesn't it let those romantic

islands alone, or open up so we can motor to Hawaii? Why can't it . . . Oh, well, have it your own way. I suppose it does yield a lot of fish and let ships ride on it, but when I want to go to Tahiti, it gets in my hair.

* * *

Secret Hut

The secret is out but it is still a secret, and it seems to be one of that rare kind that can be kept.

Last night I stayed on the Island to hear Arthur Brown, Jr., expatiate upon the architecture of the Exposition. "Here," thought I, "we will learn what was the source of inspiration that brought about the finest of expositions." But there was no sale.

Several months ago the late George Kelham, then Chairman of the Board of Architects, in a public address, said the style of Exposition architecture was late Yerba Buena. We all concluded that George was hiding something, that he was going to keep what he knew of the Ponce de Leon of Architecture to himself . . . and he did. But we were confident that sooner or later some one would let the cat (or catacomb) out of the bag. So when we read that Arthur Brown, Jr., was going to discuss the subject at a meeting of the Architectural Club we thought the time had come. We were disappointed.

None was disappointed in Arthur's talk. On the contrary, but he didn't tell us whence came the inspiration nor how in the devil the Architectural Commission got so much beauty out of mere wood and plaster. He told us the plan was simple, but that was no help. Mr. Delano, of the New York Exposition, said he was very much impressed with the simple beauty of the entire layout. Who isn't? Arthur then dilated upon the subject of the marvelous site and the fact that the old principles of design had stood up well.

This was all very interesting but gave no inkling of the details of design nor how they came about. Perhaps the architects got off their usual diet. Maybe they lived on manna. We all wanted to know. Something unknown to the profession must have been used to attain such beauty. Oh, well, let him keep his old secret.



St. Louis Dairy Company's "World's Finest Dairy Plant," St. Louis, Mo. Architects, G. K. Wolf, W. S. Sutton, J. K. Anderson



**FREE HANDBOOK FOR ARCHITECTS
AND BUILDERS**

KRAFTILE COMPANY — Niles, California
Please send me without cost or obligation "Handbook of Specifications and Suggestions on Glazed Terra Cotta Wall Units" ()
Please have service representative call ()

Name _____

Address _____

City _____

State _____

1/3 LESS LABOR TO ERECT THESE SELF-TILED PARTITIONS

THEY CUT LABOR COSTS ABOUT one-third . . . these new Kraftile Terra Cotta Wall Units. One craft for the whole job! And the partition wall is "automatically tiled" with a smart, everlasting Kraftile surface.

This beautiful semi-matt Kraftile finish is higher fired than ordinary tile surfaces — therefore resists the hardest abuse. It is fireproof, steam proof and stain proof. The color cannot fade.

Kraftile Wall Units are *precision-sized* to within 1/16 inch. Standard 6 x 12 and 8 x 16

sizes and shapes to build any wall. Easily reinforced for earthquake resistance to surpass California State Code requirements.

Kraftile Wall Unit installations are proving their worth in schools, hospitals, food products plants, laboratories, and public buildings in 21 of the states and Canada. Our Engineering and Designing Department worked closely with the builders of many of these jobs. This experience is yours for the asking. Mail coupon today.

KRAFTILE TERRA COTTA WALL UNITS

THE ARCHITECT AND ENGINEER

The Architect & Engineer

Fred W. Jones, Editor

Mark Daniels, A. I. A. Associate Editor

Edgar N. Kierulff, Assistant Editor

CONSULTING BOARD OF EDITORS

Architectural—

Arthur Brown Jr.
Frederick H. Meyer
Timothy L. Pflueger
Will G. Corlett
Harry Michelsen
John J. Donovan
Lewis P. Hobart
David C. Allison
Gordon B. Kaufmann
Harris C. Allen
Glenn Stanton
Paul R. Hunter
C. H. Alden

Engineering—

H. J. Brunner
L. H. Nishkian
William Adrian
Wm. H. Popert
Homer N. Hadley
John J. Gould
Geo. E. Atkins

Advertising Manager—

J. Leslie Meek

Architects' Reports—

Vernon S. Yaillop

THE ARCHITECT AND ENGINEER, INC., 68 Post Street, San Francisco, EXbrook 7182. President, K. P. Kierulff; vice-president, Frederick W. Jones; secretary, L. B. Penhorwood. Los Angeles office, 832 W. Fifth Street. Published on the 12th on each month. Entered as second class matter November 2 1905 at the Postoffice at San Francisco California, under the Act of March 3, 1897. Subscriptions, United States and Pan America, \$3.00 a year; Foreign countries, \$5.00 a year; single copy \$.50.

• Contents for March, 1939

Text

REPORT OF THE JURY FOR THE SELECTION OF HONOR AWARDS, LOS ANGELES	17
LOS ANGELES COUNTY CIVIC CENTER	29
WYVERNWOOD HOUSING PROJECT	31
ARCHITECTURE YESTERDAY AND TODAY	43
BUILDING TRENDS ON THE PACIFIC COAST	44
BUILDING THE WORLD'S LARGEST DAM	45
Guy F. Atkinson	
BUILDING INVESTMENT PROSPECTS	50
Lloyd E. Graybiel	
BEING AN ARCHITECT IN 1939	51
Wm. Orr Ludlow	
TREND TOWARD GROUP PURCHASE OF HOMES	53
Travis G. Walsh, Architect	

Plates and Illustrations

COLUMBIA SQUARE BROADCASTING STUDIOS, HOLLYWOOD	16
SOUTHERN CALIFORNIA HONOR AWARDS	17-27
(For complete listing, see Page 15)	
CONTEMPORARY AND OTHER WORK BY LOS ANGELES ARCHITECTS	28-47
(For complete listing, see Page 15)	
PROGRESS VIEWS OF GRAND COULEE DAM	46

FRANK LLOYD WRIGHT AGAIN

at least he has the courage of his convictions

Following a recent lecture in Washington, D. C., Frank Lloyd Wright was asked this question in an open forum discussion:

Who should design government buildings—private architects or government employees?

Answer: Certainly not government employees, because no employee is free to do creative work. And I am not so sure about private architects as they stand at present. I think if we could forget about "official" designing, allowing buildings to be built simply, naturally, by builders—their hands in the mud of the bricks of which the buildings are made, a lot would come out of the ground a little more simply for the honest purposes of life—forgetting entirely "architecture" as we have now come to know it from the books. I think something good might then happen. I think we could somehow get many "traditions" off our necks in order that the great "traditions" might live and we would learn to see that in truth the cultural lag persists and obstructs our path by way of too many little traditions with no great sense at all of Tradition. Then I think what we call great-building might live again among us. But what hope when building has been turned over lock, stock and barrel to college boys who are now in training to the books?

Q. If private capital will only build for profit, and Government will not build except on the old lines, how shall we hope for change in building conditions?

A. That I leave up to you as it is now squarely up to all of us.

Q. You have made obvious criticism of conditions of today—have you anything constructive to offer?

A. I do not think what I have said has reached this gentleman behind the flag of December 7, 1887, hanging over the balcony over his head. So I ask you of what use for me to come here and speak to him? Perhaps he has not been listening. I have said constructive things but there must be a lot of destructive work, much satire before anything can be done in America today that is really constructive. I have planted organic buildings all around the world—over 200 of them I said—themselves in the nature of the thing. If they mean nothing then what can I say that would mean anything constructive?

Q. In domestic architecture, what do you say are the trends for small families?

A. Building small homes for the small families of little or no means is a very definite trend in the life of our country now. And—means or no means—I see that everybody is eager for space. The sense of space has become an American characteristic. Perhaps the new ideal of freedom we call Democracy had something to do with it. We will no longer be pigeonholed by way of classic colonialisms or by anything else, I think. My prescription for a modern house? Is—a good site. Pick that one at the most difficult spot—pick a site no one wants—one that has

features making for character; trees, individuality, a fault of some kind in the realtor's mind. That means getting out of the city. Then—standing on that site, look about you so that you see what has charm. What is the reason you want to build there? Find out. Then build your house so that you may still look from where you stood upon all that charmed you and lose nothing of what you saw before the house was built. See that architectural association accentuates character. Now, if you want a diagram. Just come in sometime!

Q. What do you think of the Jefferson Memorial?

A. Representative Amle asking the question and he knows damn well what I think of the memorial but thanks to him for the "come on." That belated monstrosity is obviously across the grain of indigenous American feeling for architecture. It is the greatest insult yet and pure extravagance as such.

Q. The highest culture has always been achieved by nations which are almost on the decline, or at least have passed through the many stages of civilization. We are in that era now. Do you think we are justified in expecting the architects to do away with the culture lag?

A. You can wait for the lag to take itself off if you want to. I am not going to wait!

COMPETITIONS

The Smithsonian Gallery of Art Commission has announced an open competition to select an architect for the proposed new art museum in Washington to be known as the Smithsonian Gallery of Art.

There will be ten prizes as follows: First, \$7,500; second, \$3,500; and eight prizes of \$1,000.

The competition will be in two stages. The first stage is open to all practicing architects who are American citizens. The second stage is open to ten architects who will be chosen from among those competing in the first stage of the competition. Each participant in the second stage will receive a prize. In addition to receiving the first prize the winning architect will be recommended by the Art Commission to be employed as architect at a fee of \$18,000 to design the building in collaboration with the United States Treasury Department, Procurement Division, if and when funds are available.

The Jury of Award, whose choice will be final, will be composed of Frederic A. Delano, Chairman of the National Capital Park and Planning Commission, who will act as Chairman; John A. Holabird, of Chicago; Walter Gropius, Professor of Architecture at Harvard University; George Howe, of Philadelphia, and Henry R. Shepley of Boston.

Joseph Hudnut, Dean of the Faculty of Design, Harvard University, will act as Professional Adviser and Thomas Dabney Mabry, Executive Director of the Museum of Modern Art, New York City, will act as Technical Adviser. Copies of the Program may be obtained from Dean Hudnut of Harvard.

Entries for the Second Annual National Competition for students of interior decoration, conducted by James H. Blauvelt in collaboration with Country Life Magazine, may be submitted until May 1 to James H. Blauvelt & Associates, 38 East 57th Street, New York City.

The Department of Landscape Architecture, Harvard University, offers to men eligible for admission as regular students, a competitive scholarship for the next academic year with an income of \$400 equal to the tuition fee. All inquiries should be received before March 31 and addressed to: The Chairman, Department of Landscape Architecture, Robinson Hall, Cambridge, Mass.

Three fellowships in architecture have been announced by Dean George S. Koyl, of the University of Pennsylvania School of Fine Arts, Philadelphia, for the academic year 1939-40. Detailed information will be furnished by Dean Koyl on application, not later than April 1.

A competition for the design of a memorial building in honor of the first settlers of Los Angeles, is being sponsored by the State Association of California Architects, Southern Section, open to all dues-paying members in the South. The competition closes April 14, at the Association office, 3757 Wilshire Boulevard. Three prizes of \$100, \$50, and \$25 will be awarded to architects submitting the three best designs.

A competition to develop the proper use of glass block, is sponsored by the Owens-Illinois Glass Company. Open to architects, architectural designers and architectural draftsmen, the competition has the approval of the American Institute of Architects. There will be a series of 4 contests, the first for the best design of a Small House. Closing date is midnight, May 22. Subjects of the other competitions are a Group of Three Stores, a Dairy, and a Newspaper Plant. Programs may be obtained by addressing the professional adviser, Henry H. Saylor, 9 Rockefeller Plaza, New York.

CABOT'S QUILT

for

Sound Deadening
Thermal Insulation
Fire Resistant.
Vermin Proof

GUNN, CARLE & CO.

SAN FRANCISCO

20 Potrero Ave. UNDERHILL 5480



Life is lived *in kitchens, too!*



Bathrooms, too, can be planned for more pleasant living and the extra convenience that modern families want. Crane can give you valuable and useful ideas in planning the complete bathroom for practically any size of space. You'll find such information ready for your use in the Crane Bathroom Planner. Make use of this service.

A KITCHEN is a workroom—of course. But it's also a room where *life is lived*, often by many members of the family. And so, many of today's most popular kitchens combine step-saving efficiency with arrangements and features that contribute to more pleasant living. When such a kitchen is required, CRANE can help you plan it.

Crane offers you a wealth of ideas on fitting the kitchen more closely to individual family needs . . . on making the kitchen more "fun" to use. For Crane has pioneered Family-Planned Kitchens . . . sponsor-

ing kitchen improvements that are solid and permanent in value, rather than merely novel. Crane offers equipment embodying the latest, proved efficiency features—sinks that eliminate work because they are better fitted to their function. And Crane backs the architect's judgment with products of unquestioned quality and honest workmanship . . . obtainable within every price range. For aid in planning more useful, more pleasant kitchens, use your Crane Architect's Catalog—and visit a Crane Display Room!



CRANE

CRANE CO., GENERAL OFFICES: 836 SOUTH MICHIGAN AVENUE, CHICAGO
VALVES • FITTINGS • PIPE • PLUMBING • HEATING • PUMPS

NATION-WIDE SERVICE THROUGH BRANCHES, WHOLESALERS, PLUMBING AND HEATING CONTRACTORS

MARBLE-GLASS

**the New,
Structural
Sheet Glass
Building Material
Combines
Beauty, Permanence,
Distinction, Economy,
Cleanliness**

Not just another marble substitute, Marble-Glass lends itself to a wide variety of applications, designs and effects not possible through the use of any other product.

Physical characteristics of Marble-Glass are identical with plate glass. The exterior, or exposed surface, is the glass itself. An exact replica of the pattern of any desired type of marble—or any other design is obtained by a patented method—and fired into the back surface, fusing the colors and glass into one inseparable piece.

Uses of Marble-Glass are practically unlimited, as it is not subject to stain or mar from lactic acids, alcohol, moisture, or fading from sun rays.

MARBLE-GLASS IS ADAPTED TO THE FOLLOWING USES:

- | | |
|---|-------------------------------------|
| 1. Store fronts | 7. Confectioneries |
| 2. Corridors and vestibules | 8. Hotels |
| 3. Beauty parlors | 9. Office buildings |
| 4. Table and desk tops | 10. Kitchens, showers and bathrooms |
| 5. Facing, tops for counters, fountains | 11. Hospitals |
| 6. Restaurants | 12. Theatres |

Let us submit samples for your inspection.

MARBLE-GLASS CORPORATION

Russ Bldg., San Francisco
Tel. SUtter 8081

MARBLE-GLASS

By FRED JENNINGS

Combining outstanding beauty, distinction, permanence, cleanliness and economy, Marble-Glass, a new product, provides a structural sheet glass building material which offers many advantages in individual design of character.

More beautiful than marble, it lends itself to a wide variety of applications, designs and effects which cannot be obtained through use of any other product. Marble-Glass may be translucent or opaque. The translucent product finds wide application in exposed areas providing an ornamental surface, yet admitting light. Floodlighting such translucent installations from the interior at night produces an effect that is beautiful beyond description.

The physical characteristics of Marble-Glass are identical with plate glass. The exterior or exposed surface is fired into the rear surface in such a manner as to fuse the colors and glass into one inseparable sheet. It is economical to maintain, as it requires no polishing, filling, honing or varnishing. Clear water alone cleans the glass surface and restores all of the original lustre.

Used as a decorative facing for store fronts, hotel lobbies, vestibules, and corridors, Marble-Glass contributes matchless beauty, richness and character in a variety of designs limited only by the imagination of the architect. Patterns of different color and combinations of gold, silver or other tones may be inlaid on the slab to suit the demands of the designer.

As an advertising and decorative medium, Marble-Glass lends itself admirably to use in conjunction with Neon signs and lighting effects. Any type of script, character lettering or special design may be reproduced and is clearly visible from any angle without distortion. As the lettering or designs are sandblasted or etched into the rear surface and, therefore, protected by the glass plate, they are permanent, requiring no cleaning or other upkeep. Likewise, the neon tubing is concealed and protected behind the panels, reducing its maintenance to a minimum and eliminating the unsightliness of ordinary neon in the daytime.

Veining may be matched from panel to panel or around corners. Mitered, beveled or rounded corners may be obtained. Panels may be bent to form columns, arches or other special shapes.

Marble-Glass has, so far, been adapted to the following uses: store fronts, vestibules and corridors, beauty parlors, table and desk tops, facing and tops for counters and fountains, restaurants, confectioneries, hotels, office buildings, kitchens, showers, and bathrooms, hospitals, and theaters.

COURT HOUSE REMODELING

Working drawings are practically complete for remodeling the old Alameda County Court house at Fourth Street and Broadway, Oakland. When the improvements are completed the building will be used as a morgue. John J. Donovan is the architect.

KRAFTILE WALL UNITS GIVE LIGHT AND COLOR



IN THE TREATMENT ROOM OF THE MEDICAL BUILDING OF OWENS-ILLINOIS PACIFIC COAST COMPANY AT VERNON (PICTURE BELOW) THE MATERIAL USED AFFORDS MAXIMUM LIGHT AND EASE IN KEEPING THE ROOM IMMACULATLY SANITARY. SURMOUNTING THE TRANSLUCENT GLASS BLOCKS IN THE PARTITION IS A CAPPING OF KRAFTILE TERRA COTTA WALL UNITS OF TUOLOMNE GREEN TO LEND COLOR. THE BASEBOARDS AND FACING OF THE PILLAR ARE OF PURE WHITE.

BY COMBINING GLASS BLOCKS AND TILE, CHEERFUL LIGHT AND PLEASANT COLOR ARE ATTAINED IN THE LOCKER ROOM FOR WOMEN EMPLOYEES AT THE VERNON PLANT OF OWENS-ILLINOIS PACIFIC COAST COMPANY. HERE THE GLASS BLOCK UNITS ARE BROUGHT TO THE FLOOR, WITH KRAFTILE USED AS CAPPING FOR THE PARTITION.

LOS ANGELES INDUSTRIAL BUILDING

BOTH in appearance and in construction, the Vernon plant of Owens-Illinois Pacific Coast Company is an entirely modern industrial building.

From its glass tower which dominates the view from the street, to its small detached building which serves for medical aid, close attention was given to all modern phases of industrial engineering.

Handling of interiors included the employment of partitions made of Insulux blocks combined with Kraftile terra cotta wall units. The glass blocks, affording light, are thus complemented by color in tile. This combination of materials results in many advantages, including cost of installation, structural and fire-resistant standards, economy of upkeep and pleasantness of appearance gained by the attractive quality of light and the cheerfulness of color.

Albert F. Roller of San Francisco was architect of the building and H. J. Brunner, the structural engineer.



TIME - - THE WRECKER

Time has always been man's adversary. Especially does time seem to delight in sweeping along at such a pace that man-made buildings are **outmoded** in a few brief years, even if they are still sound.

Today living is geared to a faster pace than ever before and time takes its toll in buildings which outlive their modernity and efficiency in an even briefer number of years than before.

No service is more important in modern buildings than the electric service, and no service is so swiftly outgrown. We are told that the electrical age has just commenced and that succeeding years will see tremendously increased use of electricity in homes and every type of commercial building.

The electrical service that goes into your buildings today is more important to the useful life of that building than ever before. Limited electrical service will throttle the building's useful life and make trouble and expense for the owner.

Include generous electric service in your plans. Then if the owner does not follow your recommendations, you cannot be criticized for failure to provide proper electrical service plans.

See the electrical exhibits at the Palace of Electricity and Communications at the Golden Gate International Exposition

PACIFIC COAST ELECTRICAL BUREAU

447 SUTTER STREET • SAN FRANCISCO, CALIFORNIA

UNIT-BUILT STEEL HOME ON TREASURE ISLAND

Designed by Architect J. K. Ballantine of San Francisco and built by the G. W. Williams Company of Burlingame, the Soule Unit-built steel home at Treasure Island was formally inspected by invited guests March 7th. To many, this model home was a revelation. That it is going to interest the public in search of new ideas and the latest developments in building materials, has been evidenced since the opening day by the throngs of people who have visited the house. Located opposite the Palace of Fine Arts, it is usually accessible and the fact that no other building is close by helps to give the house an attractive setting. Grass and flowers will soon be growing around the place to add to its beauty.

Edward Soule, president and manager of the Soule Company, acted as master of ceremonies or rather, chairman of the reception committee, and he was graciously aided by members of his business staff, as well as officials of the Columbia Steel Company, fabricators of the steel which makes the house as near 'quake and fire resistant as it is possible for such type of building to be. The house is low to the ground, California ranch style, and has five rooms with plumbing, electrical and heating equipment modern to the very last word.

This house was built in barely 30 days with the co-operation of San Francisco and Oakland firms, leaders in their respective lines. The house may be duplicated on a level lot for something like \$5800. Here are the firms that contributed to the success of the project:

Brick—United Materials and Richmond Brick Co.
Cement—Santa Cruz Portland Cement Co.
Furnace and air conditioning—Aladdin Heating Co.
Garage door hardware—The Stanley Works
Glass—W. P. Fuller & Co.
Marble—Eisele & Dundero
Paint—The Paraffine Companies, Inc.
Plastering aggregates—Ready-mix Concrete Co.
Plumbing fixtures—Crane Company
Roofing tile—Johns-Manville Company
Screens—Roll-away Screen Company
Stainless steel shower door—Stainless Metal Products Company
Stainless steel sink—Ward Refrigerator Company
Steel doors and windows—Soule Steel Company
Steel kitchen cabinets—Ward Refrigerator Company
Steel products—Columbia Steel Company
Steel Venetian blinds—Ry-Lock Company, Ltd.
Stucco paper—Western Asbestos Company
Tile—Gladding, McBean & Company
Water heater—Crane Company
Wire fence—Standard Fence Company
Wolmanized lumber—American Lumber & Treating Company

ATHERTON RESIDENCE

Leo J. Sharps of Burlingame, has awarded contracts for an eight room \$14,000 residence to be built in the Lindenwood Tract, Atherton, for Mrs. Miller.

1938 HONOR AWARDS



COLUMBIA SQUARE, COLUMBIA BROADCASTING SYSTEM, HOLLYWOOD, CALIFORNIA
WILLIAM LESCAZE, ARCHITECT; EARL T. HEITSCHMIDT, ASSOCIATE ARCHITECT

Southern California Chapter, A. I. A.
Honor Award

RECENT ARCHITECTURE IN LOS ANGELES

GUEST EDITOR, PAUL ROBINSON HUNTER

1938 Honor Awards

SOUTHERN CALIFORNIA CHAPTER, AMERICAN INSTITUTE OF ARCHITECTS

Columbia Square, Hollywood	<i>William Lescaze and Earl Heitschmidt, Associate</i>
Los Angeles Times Building	<i>Gordon B. Kaufmann</i>
Los Angeles County Medical Association Library	<i>Gordon B. Kaufmann</i>
W. & J. Sloane Company, Beverly Hills	<i>John and Donald Parkinson</i>
Twenty-Fifth Church of Christ Scientist	<i>H. Roy Kelley</i>
Library, First Church of Christ Scientist, Pasadena	<i>Marston & Maybury</i>
Los Angeles Branch, Federal Reserve Bank of San Francisco	<i>John and Donald Parkinson</i>
United States Post Office, Beverly Hills	<i>Ralph C. Flewelling</i>
Science Building, Hollywood High School	<i>Marsh, Smith & Powell</i>
Miles Avenue School, Huntington Park	<i>Ralph C. Flewelling</i>
Strathmore Dwellings	<i>Richard J. Neutra</i>
Morrison Horticultural Center, Pasadena	<i>Fitch H. Haskell</i>
La Vina Sanitorium, La Vina	<i>Myron Hunt and H. C. Chambers</i>
Library, Webb School for Boys, Claremont	<i>Myron Hunt and H. C. Chambers</i>
American Red Cross Building, Pasadena	<i>William S. McCay</i>

Current Projects

Los Angeles County Civic Center	<i>John C. Austin</i>
Wyvernwood Housing Project	<i>Witmer & Watson</i>
Harris College of Architecture and Fine Arts and Elizabeth Holmes Fisher Gallery, University of Southern California	<i>Ralph C. Flewelling</i>

Residences

Mr. and Mrs. Joseph Koeffli, San Marino	<i>Cameron & Topp</i>
Mr. and Mrs. Arthur Hornblow, Jr.	<i>Roland E. Coate</i>
Residence in San Marino	<i>Melvin N. Garlough</i>
Mr. and Mrs. Vernon G. Larsen, San Marino	<i>Edgar F. Bissantz</i>
Mr. and Mrs. George C. Bauer, Glendale	<i>Harwell Hamilton Harris</i> <i>Carl Anderson, Associate</i>
Mr. and Mrs. Foster K. Sampson	<i>Theodore Criley, Jr.</i>
Small Home Service Residence	<i>Spencer & Landon</i>
Small Home Service Residence	<i>Paul Robinson Hunter</i>
Mr. and Mrs. J. E. Krieger, Bel-Air	<i>Winchton L. Risley</i>

Allied Arts

Paddock Garden, Santa Anita	<i>Tommy Tomson</i>
Hooper Avenue School	<i>Edgar F. Bissantz and S. Wright MacDonald</i>



LOS ANGELES TIMES BUILDING, LOS ANGELES
GORDON B. KAUFMANN, ARCHITECT

Southern California Chapter, A. I. A., Honor Award

REPORT OF THE JURY FOR THE SELECTION OF HONOR AWARDS Southern California Chapter, American Institute of Architects

ROLAND E. COATE

GARDNER A. DAILEY

ERNEST E. WEIHE

IN making these awards the Jury wished to be guided, in so far as they were capable, by basic considerations of architectural design alone. It became obvious that such considerations as the size of the building, the apparent cost, the location, the usage, whether prominent or obscure in the public eye, were all incidental qualities that were relatively unimportant.

In general the Jury based its selections on simple and effective architectural forms and on the honest expressions of the materials used. We felt that design does not gain quality through the introduction of extraneous elements. Within the limited time at our disposal we tried to judge how well the building had been planned for its use, realizing full well how important is this one factor alone in the achievement of successful architectural design. As far as possible the Jury also tried to recognize the fact that the buildings to be judged had been built over a considerable period of years and that changes in architectural fashions could be expected during that time. Our difficult task was to try to distinguish merit from novelty and to award, to the best of our limited ability, the successful application of the timeless principles of good architectural design.

With these thoughts in mind, your Jury submits their selection of buildings for the special distinction of the "Honor Award."

Editor's Note—The purpose of the Honor Awards Program is to stimulate the creation of better architecture in Southern California by honoring the Owners, Architects and Craftsmen who collaborate in the development of commendatory buildings—and by fostering an appreciation of good taste in building, through the exhibition of the selected work.



LOS ANGELES COUNTY MEDICAL
ASSOCIATION LIBRARY, LOS ANGELES
GORDON B. KAUFMANN, ARCHITECT
Southern California Chapter, A. I. A., Honor Award

THE ARCHITECT AND ENGINEER



W. & J. SLOANE COMPANY, BEVERLY HILLS, CALIFORNIA
JOHN PARKINSON AND DONALD B. PARKINSON, ARCHITECTS

Southern California Chapter,
A. I. A., Honor Award



Photo by Haight

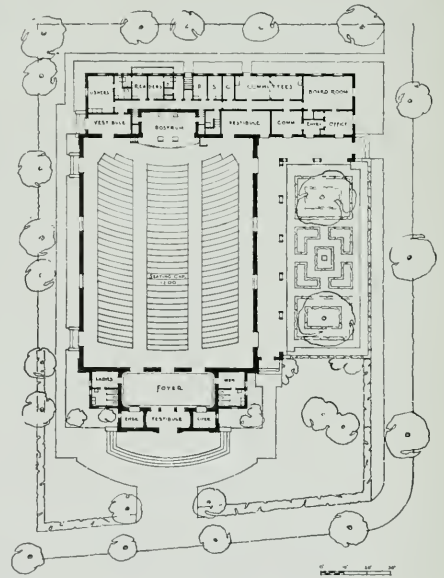

TWENTY FIFTH CHURCH OF CHRIST SCIENTIST,
LOS ANGELES

H. ROY KELLEY, ARCHITECT

Southern California Chapter, A. I. A., Honor Award



LIBRARY, FIRST CHURCH OF CHRIST
SCIENTIST, PASADENA

MARSTON AND MAYBURY,
ARCHITECTS

Southern California Chapter,
A. I. A., Honor Award



LOS ANGELES BRANCH, FEDERAL
RESERVE BANK OF SAN FRANCISCO

JOHN PARKINSON AND DONALD B.
PARKINSON, ARCHITECTS

Southern California Chapter,
A. I. A., Honor Award



UNITED STATES POST OFFICE, BEVERLY HILLS, CALIFORNIA
RALPH C. FLEWELLING, ARCHITECT

Southern California Chapter,
A. I. A., Honor Award



SCIENCE BUILDING, HOLLYWOOD HIGH SCHOOL
MARSH, SMITH AND POWELL, ARCHITECTS

Southern California Chapter,
A. I. A., Honor Award



MILES AVENUE SCHOOL, HUNTINGTON PARK
RALPH C. FLEWELLING, ARCHITECT

Southern California Chapter,
A. I. A., Honor Award



KINDERGARTEN, MILES AVENUE SCHOOL



STRATHMORE DWELLINGS, LOS ANGELES
RICHARD J. NEUTRA, ARCHITECT

Southern California Chapter,
A. I. A., Honor Award



Southern California Chapter, A.I.A., Honor Award

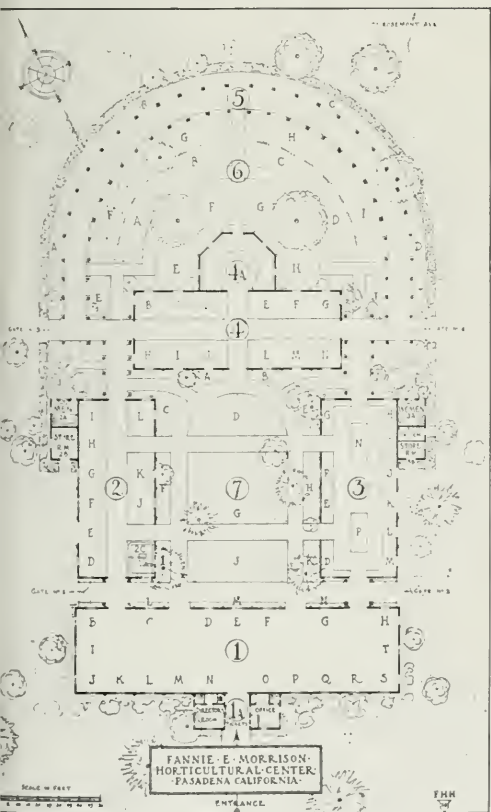

FANNIE E. MORRISON HORTICULTURAL CENTER,
PASADENA, CALIFORNIA

FITCH H. HASKELL, ARCHITECT



LA VINA SANATORIUM, LA VINA
MYRON HUNT AND H. C. CHAMBERS, ARCHITECTS

Southern California Chapter,
A. I. A., Honor Award



TERRACE, LA VINA SANATORIUM

Photo by Haight



LIBRARY, WEBB SCHOOL FOR BOYS, CLAREMONT
MYRON HUNT AND H. C. CHAMBERS, ARCHITECTS

Southern California Chapter,
A. I. A., Honor Award



AMERICAN RED CROSS BUILDING, PASADENA
WILLIAM S. McCAY, ARCHITECT

Southern California Chapter,
A. I. A., Honor Award

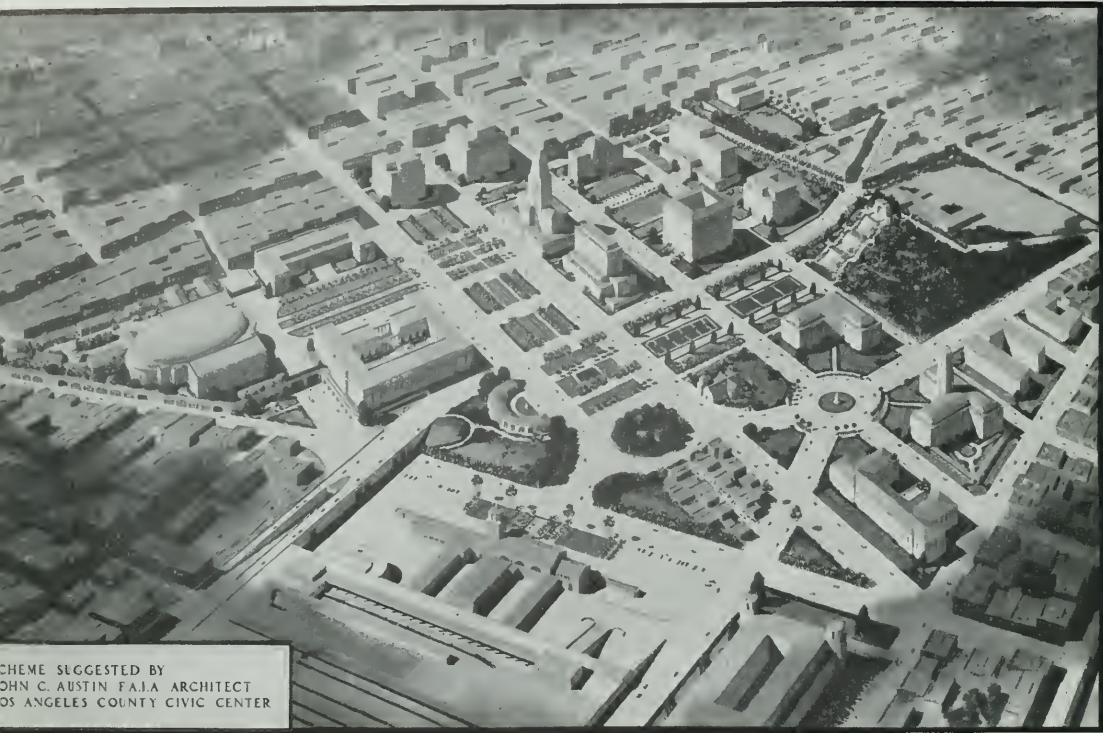

SCHEME SUGGESTED BY
JOHN C. AUSTIN F.A.I.A. ARCHITECT
LOS ANGELES COUNTY CIVIC CENTER

LOS ANGELES COUNTY CIVIC CENTER

LOS ANGELES, although one of the principal cities of the United States, has long been handicapped by a Civic Center inadequate in size and lacking in spaciousness and dignity. In connection with a petition of the County Board of Supervisors to the Public Works Administration for a Federal grant, the plan illustrated on the opposite page was prepared by John C. Austin, architect, in August, 1938, for the Los Angeles County Development Committee. This plan includes a number of elements that have long been fairly well agreed upon and other points that are still under consideration; it is regarded by many as the finest scheme that has yet been developed and one that may well serve as a guide during the next few decades.

THIS plan develops the Civic Center within the area bounded by First, Alameda, Ord, and Olive Streets. The unsightly and dilapidated houses and stores in this area have been replaced by new public buildings, broad streets and parkways. In the center of the illustration will be noted the present towered City Hall, the State Building, the Public Square, open-centered Hall of Justice, and the Federal Building. At the bottom is the new Union Passenger Terminal. On the axis of the City Hall and to the west is placed a County Courthouse, and north of it a Police Administration Building. East on the same axis, is situated a Civic Auditorium with an auto park beneath. Flanking the Auditorium are two proposed Trade Exhibit Buildings. The circle above the Union Passenger Terminal is the old Plaza and near it the Plaza Church and Olvera Street, which are to be preserved. About the point at the intersection of Spring Street and Sunset Boulevard are placed buildings for the County Engineer and the Customs Offices. Aliso Street has been extended into this area by a viaduct and north of it has been created a parkway, terminated by an exedra and a Memorial Cascade.



PADDOCK GARDEN, SANTA ANITA

TOMMY TOMSON, LANDSCAPE ARCHITECT

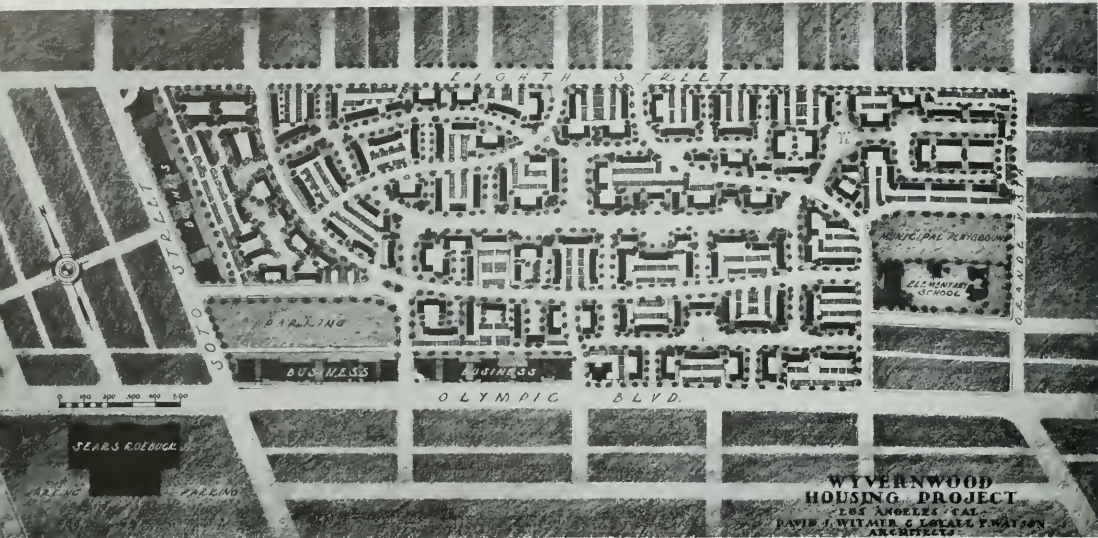

GENERAL PLAN, WYVERNWOOD

WITMER & WATSON, ARCHITECTS

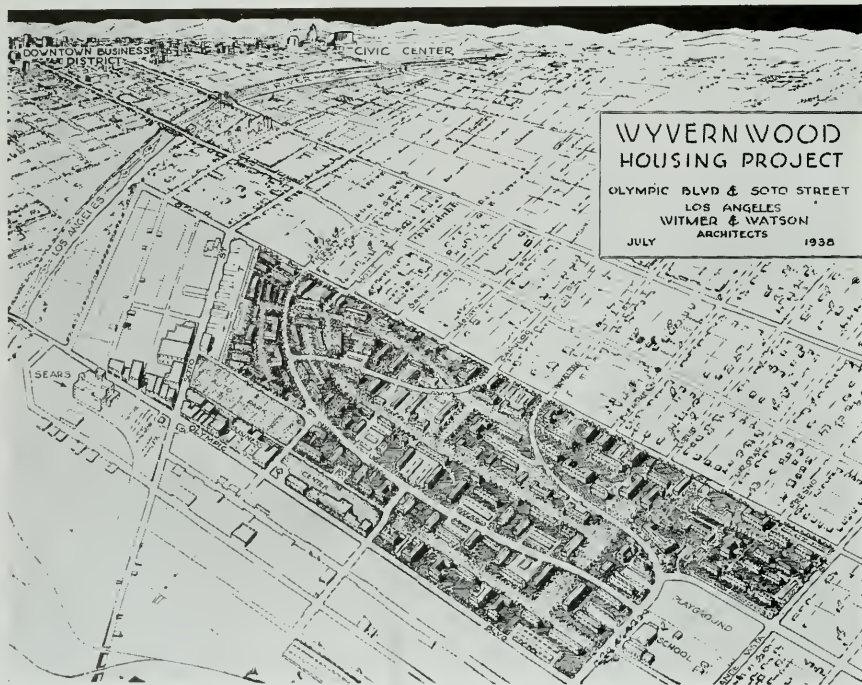

VIEW SHOWING RELATION OF WYVERNWOOD TO METROPOLITAN LOS ANGELES



SECTION OF ONE OF SEVERAL TYPICAL UNITS, WYVERNWOOD

WITMER & WATSON, ARCHITECTS

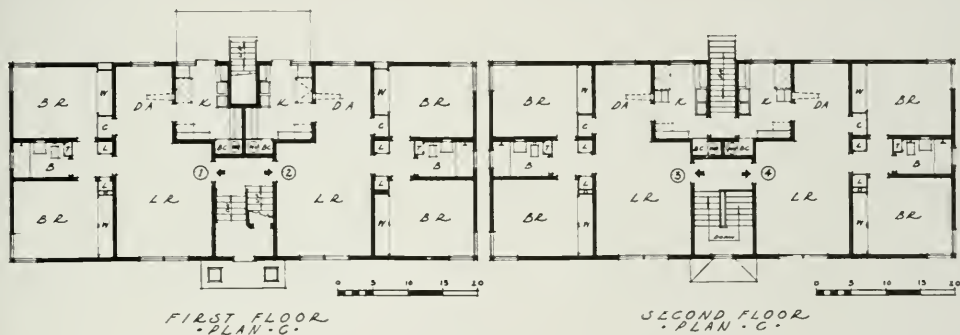

WYVERNWOOD HOUSING PROJECT

WYVERNWOOD is the first large-scale housing project in Los Angeles and is located on 70 acres of rolling land in a residential district some two miles east of the center of the city. It is a private enterprise financed by a \$3,000,000 loan, the largest single loan for which a Federal Housing Administration insurance commitment has been issued.

THE purpose of the project is to provide at a low monthly rental, modern, comfortable, and well-equipped homes for families with children. It is a small city itself, with a shopping center, nearby schools, play areas and recreational facilities protected from traffic hazards. One of the principal features of the plan is the landscaping, which will create the impression of homes situated within a beautiful park. The project has 1116 residential units of three, four and one-half, and six rooms, combined into 145 two-story buildings of nine basic types, of which type "C" is illustrated above. The design insures privacy for each resident and convenient accessibility to every dwelling, with 114 garage compounds, so arranged that each is within fifty feet of the unit it serves.

THE first group of units is expected to be completed this month. The construction schedule calls for the completion of one building each day, after the first one, and the entire project is expected to be finished in from nine to ten months.

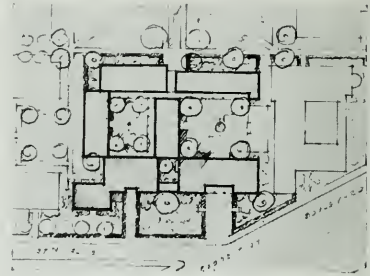
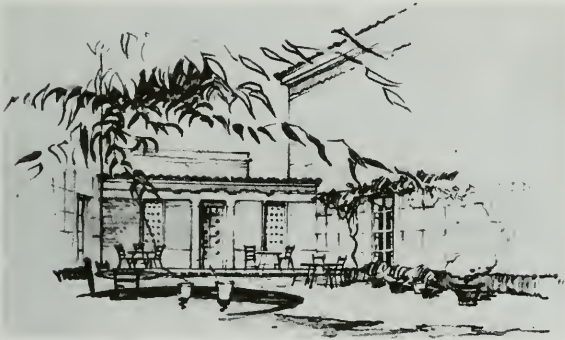

PLOT PLAN

HARRIS COLLEGE OF ARCHITECTURE
AND FINE ARTS AND
ELIZABETH HOLMES FISHER GALLERY
UNIVERSITY OF SOUTHERN CALIFORNIA

RALPH C. FLEWELLING
ARCHITECT

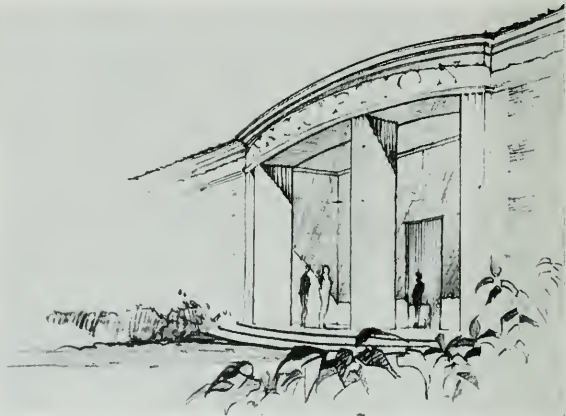



AUDITORIUM, HOOPER AVENUE SCHOOL, LOS ANGELES

EDGAR F. BISSANTZ, ARCHITECT

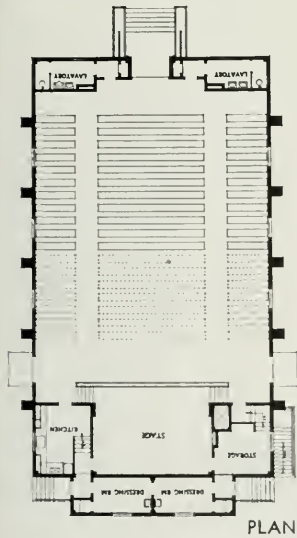

PLAN



MOSAIC, S. MacDONALD WRIGHT, ARTIST, "SCIENCE, INVENTION, MAN." WPA FEDERAL ART PROJECT



RESIDENCE OF MR. AND MRS. JOSEPH KOEPLI, SAN MARINO

CAMERON & TOPP, ARCHITECTS



AERIAL VIEW OF HOUSE AND GROUNDS,
RESIDENCE OF MR. AND MRS. ARTHUR HORNBLow, JR.

ROLAND E. COATE, ARCHITECT

ENTRANCE TO HORNBLow RESIDENCE



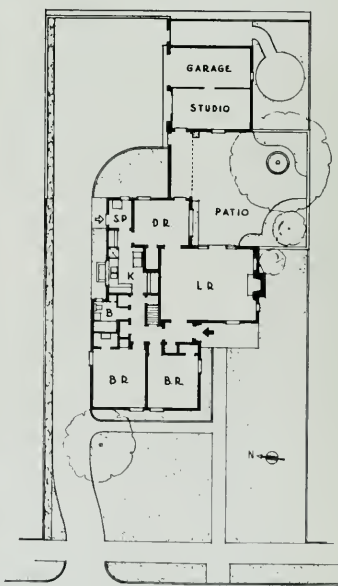

RESIDENCE IN SAN MARINO
 MELVIN N. GARLOUGH, ARCHITECT

THE ARCHITECT AND ENGINEER



RESIDENCE OF MR. AND MRS. VERNON G. LARSON, SAN MARINO, CALIFORNIA
EDGAR F. BISSANTZ, ARCHITECT



RESIDENCE OF MR. & MRS. GEORGE C. BAUER, GLENDALE
First Prize Pittsburgh Glass Institute Competition

HARWELL HAMILTON HARRIS
CARL ANDERSON, ASSOCIATE

MODEL OF BAUER RESIDENCE





MODEL OF BAUER RESIDENCE WITH ROOF REMOVED

ENTRANCE, RESIDENCE OF
MR. AND MRS. FOSTER K. SAMPSON
THEODORE CRILEY, JR., ARCHITECT



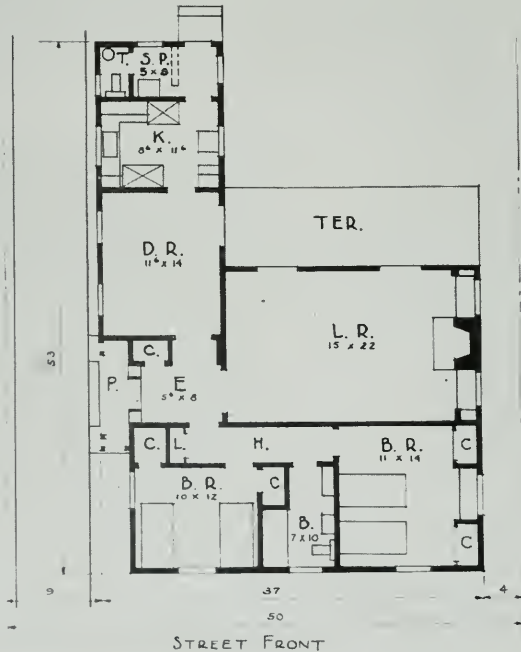

SMALL HOME SERVICE RESIDENCE

SPENCER & LANGDON, ARCHITECTS

THE Small Home Service is a non-profit California corporation, organized to coordinate the activities of architect, lending institution, contractor, and purveyor of construction materials on small house projects, for the purpose of improving quality and design, increasing construction volume, and reducing costs. The Service offers to a public a portfolio of approximately 100 plans in the cost range of \$3000 to \$6000, selected from 350 designs submitted by fifty-eight licensed architects of Southern California. The houses shown on this and the opposite page are two designs included in the first portfolio.

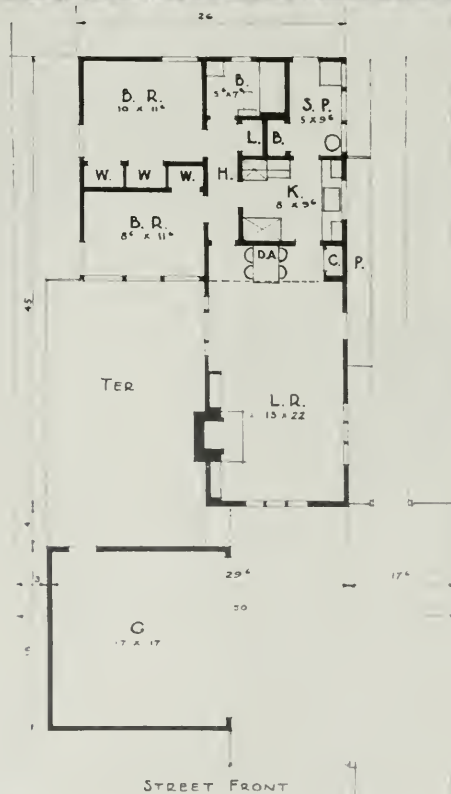

SMALL HOME SERVICE RESIDENCE

PAUL ROBINSON HUNTER, ARCHITECT

THIS Service, frankly an experiment, may open the small house field to the architect as a profitable activity, through the repeated use of the same plan, accompanied by supervision for each individual house. All matters affecting the architects participating in the Service are referred to the Architects Advisory Committee. This Committee consists of Gordon B. Kaufmann, Chairman; David J. Witmer, Vice-Chairman; George C. Andersen, Frederic Barienbrock, John N. Douglas, Henry L. Eggers, Erwood P. Eiden, H. G. Edwell, C. H. Gibbs, J. H. Hoose, P. R. Hunter, G. D. Riddle, C. A. Schilling, A. J. Wilson.



RESIDENCE OF
MR. AND MRS. J. E. KRIEGER
BEL-AIR
WINCHTON L. RISLEY, ARCHITECT

ARCHITECTURE YESTERDAY AND TODAY

A reply to an unfortunate statement credited to a Columbia University Librarian

WE note that a gentleman who is architectural librarian of Columbia University writes:

"You read of Colonial houses and English houses and Normandy houses and Gothic churches and the charm of this style and the loveliness of that style. All of that has nothing to do with architecture. We are done with all that 'parroting' of the past; mere copying of what our ancestors did is at best only attempting to recover something that has gone; and because the styles we are taught were produced by people no longer living, and for kinds of life that have passed forever with the coming of the machine, we can never even copy them with perfect sincerity."

What an unfortunate and unspeculative statement to make! Architecture, like all the arts and professions, has its roots in the past. Sane persons, in any line of endeavor, take no present steps without considering the results of similar steps taken in the past.

Architecture, of all our pursuits, can least afford to disregard the past. It is a known fact that of all works of art, be they literary, delineative or built in three dimensions, only a small percentage live to interest succeeding generations. Books, drawings, paintings which fail to hold more than passing contemporary approval are mercifully hidden in archives and storerooms or actually destroyed. Whereas architecture which fails to hold its appeal, cannot be hidden and, except in a few fortunate instances, is not destroyed.

There lies the primary responsibility of the architect. He must not be swept away by the current architectural mode, the current inspirational fancy. He must not be lured into the false security of the idea that, by repudiating the architecture of past generations, he will not himself be repudiated by the next generation. He must not put on the mantle of the prophets and say "I hereby erect an excellent architectural example which by my direction shall al-

ways continue to be an excellent architectural example."

In other words, if he is a good architect, whose work will be valued in years to come, he must have the spirit of humility. He must instruct himself that certain elusive but enduring qualities in buildings of the past have caused them to have the same allure now as in the beginning. It is a part of his culture to search out these elusive and enduring qualities so that to the full extent of his ability such qualities may also be built into his architecture.

If he thinks he can disregard those messages of the past and devise his own enduring qualities, mooning over his drawing board, he has a swelled head and he is eternally wrong.

Any architect who believes that the use of the ideas and the moods of the past is copying, and fears that someone will tell him so, has lost that independence of thought which is or should be the mainstay of his profession.

It can be said that this is an educational era, that we are laying down great thoughts for oncoming generations. Don't be too sure. How are oncoming generations to know that they are to follow the idea of this generation that the ideas of previous generations are to be disregarded.

Every architect should, of course, have full freedom of action. If, as the result of his own personal reasoning and inspiration, he decides to include in his work no evidences of study of the past, it should be his privilege. But our educational institutions should not read out of the party architects who might choose to reproduce the ideas of the past. Education and culture is the past. The present is the field of the newspaper, the future of the astrologer and crystal-gazer. If our educational institutions repudiate the past, where are they?

Every architect will sooner or later have to paste this phrase in his hat: "I must study and make use of the qualities that made buildings live from the past to the present in order that mine may live into the future."

—Federal Architect.

BUILDING TRENDS ON THE PACIFIC COAST

A page devoted to current construction activities in the Pacific Coast Area, together with late building permit figures gathered from reliable sources—a regular monthly feature of *The Architect and Engineer*.

TRENDS

Building is showing a very decided upswing and holds great promise for this current year of 1939. This should add a note of optimism to the building industry generally.

* * *

The increase in all types of building is nationwide and the Pacific Coast territory has had and is having better than a fair portion of it.

* * *

The types above referred to include the general classifications into which building falls as follows, industrial, public, semi-public, residence—including all classes of family dwellings—and private construction other than residence.

* * *

Industrial construction, modernization and rehabilitation is keeping level with the steady growth in residential building which latter, however, still lacks sufficient volume to fill the shortage of dwellings.

MATERIALS

The cost index figures for 1938 indicate that building materials stood at 90.3 for the year as against the 1926 basis of 100; there was a decline of 6% over 1937.

* * *

This is an important factor in the field of low cost housing in which building category there is anticipated the greatest activity in 1939. The cost of building materials is still far below normal, and the trend during the past two years has been downward.

STATISTICS—BUILDING PERMIT FIGURES

The following figures may be cited as indicative of the volume for the two months of this year (1939) taken from a group of the major cities and towns on the Pacific Coast, (figures are for January 1938 and 1939):

California:

	1939		1938	
	No. of Permits	Value	No.	Value
Alameda	58	\$ 116,603	50	\$ 74,201
Bakersfield	76	110,192	60	215,664
Berkeley	117	436,860	149	96,452
Beverly Hills	51	227,100	64	266,740
Eureka	58	118,407	27	16,420
Glendale	172	336,215	142	415,901
Long Beach	1,088	1,294,525	645	945,345
Los Angeles	3,016	5,879,992	2,286	5,531,440
Oakland	697	1,336,635	560	571,144
Pasadena	625,442	175,086
Sacramento	192	406,271	218	327,903
San Francisco	650	1,490,394	525	1,576,251
San Diego	392	587,488	395	445,609
San Jose	94	216,115	98	184,220
San Mateo	68	242,940	29	102,100

Oregon:

Astoria	23	28,405	25	2,651
Portland	270	339,955	280	327,145
Salem	26	52,934	73	20,244

Washington:

Seattle	370	1,008,510	269	410,705
Spokane	155	130,717	110	204,009
Tacoma	75	143,015	62	102,185

Figures for February 1939 (same cities)

Alameda	No. 59	Value \$ 105,766	Los Angeles	2,584	4,465,189
Bakersfield	74	119,189	Oakland	730	557,240
Berkeley	117	124,673	Pasadena	307	217,058
Beverly Hills	57	575,900	Sacramento	227	485,299
Eureka	42	140,666	San Diego	374	481,475
Fresno	192	251,572	San Francisco	682	1,709,814
Glendale	180	443,143	San Jose	107	232,765
Long Beach	850	943,045	San Mateo	39	152,780
			Stockton	90	81,800

BUILDING THE WORLD'S LARGEST DAM

by Guy F. Atkinson

Editor's Note—An address delivered before the San Francisco Section, American Society of Civil Engineers. The author is one of the contractors on the project. At the annual convention of the Associated General Contractors of America, held in San Francisco, March 9-11, Mr. Atkinson was nominated for the presidency of that organization.

THE Grand Coulee Dam is being built by the Bureau of Reclamation, under the Department of the Interior, as a reclamation and power project.

This project, located on the Columbia River, 100 miles west of Spokane and 260 miles east of Seattle, includes the construction of a straight gravity type dam with a base 3,000 feet long and 500 feet thick and with a crest 4,200 feet long and 30 feet thick. The dam when completed will have a height of over 550 feet above lowest point of bed rock. The dam alone will require 11,250,000 cubic yards of concrete to produce which will require 21,000,000 tons of sand and gravel aggregate and about 12,000,000 barrels of cement. The dam will have a power house on each side of the river composed of nine units each and when completed will have an installed capacity of 2,700,000 horsepower. The turbines will operate under a maximum head of 360 feet and a minimum head of 265 feet. This dam will form a lake 151 miles long which will reach to the Canadian border. In addition to furnishing power, it will furnish water for the irrigation of 1,250,000 acres of land in Eastern Washington.

In June 1934 the Bureau of Reclamation received bids for the construction of what was then called the "Low Dam" at the Grand Coulee Dam Site. The lowest bid was from a combination of Silas Mason Company of New York, Walsh Construction Company of Davenport, Iowa, and the Atkinson-Kier Company of San Francisco. This group submitted a joint bid and was awarded the contract on July 16, 1934. After the contracts were signed and bonds filed, the joint venturers organized the Mason-

Walsh-Atkinson-Kier Company with a cash capital of five million dollars. The Thompson-Starrett Company of New York, not mentioned in the bid of corporation, was also a participating partner. The Mason-Walsh-Atkinson-Kier Company proceeded to construct the foundation and base of the dam, which included the largest river control that has ever been undertaken inasmuch as there could be no diversion through tunnels. We had a river constantly with us which carried from 75,000 second feet to 375,000 second feet, with a past record estimated at over 500,000 second feet. This river diversion was a tremendous task and we had to proceed with extreme caution so that we might not be overtaken with a major disaster. We therefore, proceeded with this diversion in every case with a large factor of safety.

A CITY WITHOUT A CHIMNEY

When we arrived on the ground at Grand Coulee, there was no access to the location of our camp site on the east side of the river except a small ferry and it was therefore necessary to build a trestle bridge as quickly as possible in order that all materials and supplies could be delivered direct to the camp side of the river. There were very limited accommodations in the district at that time for workmen and it was important that a camp and cookhouse be built as soon as possible. This was accomplished in a short time and, with temporary camp and cook house open, accommodations for about 800 men were possible, thus enabling the construction of the permanent camp to proceed more rapidly. We constructed a camp which included family residences, dormitories

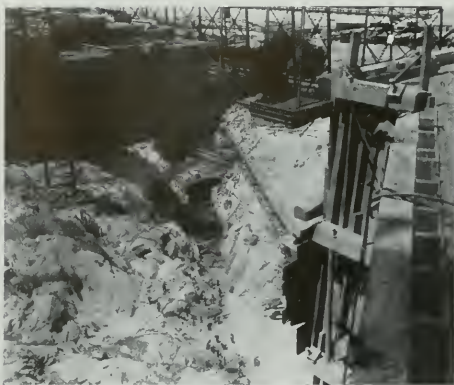

GRAND COULEE DAM PROJECT

for the single men, cook houses, office buildings, hospital, hotel, recreation hall, theater, general store and two churches—at a cost of about one and a quarter million dollars. This camp, or town, was named Mason City in honor of Silas Mason, chairman of the Board at that time, but since deceased. The town has a complete water and sewer system, oiled streets bordered with trees, and every private home has a well-kept lawn and flowers. Mason City has been called "The City Without a Chimney." This is due to the fact that all heating and cooking is done by electricity which is furnished to the employees at a very reasonable rate.

As it was necessary to have ample power for operating equipment, lighting and heating, we built a 110,000 volt transmission line 31 miles long. A large transformer station was installed from which lines were run to all parts of the work.

While we were building the camp and getting transmission lines installed, we were assembling equipment for the cofferdam work and excavation. As we had 15 million yards of common excavation to dispose of in a canyon upstream from the dam about one mile at an elevation of 800 feet above the point of excavation, it was decided to install a 60" belt conveyor. The conveyor was made of 20 sections with a 200 horsepower motor on each section and a stacker at the disposal end.

While we were getting the common excavation started, on the upper lifts, we were getting in our sheet piling and equipment for the cofferdam work. As I stated before, this cofferdam, in connection with river diversion, was the greatest problem we had on the Grand Coulee Dam. Our first diversion operation was to build a cofferdam 3,000 feet long, consisting of a series of steel-sheet piling cells filled with gravel. These cells varied in size according to location and conditions to be met. In the center portion, which was later to be removed so that we

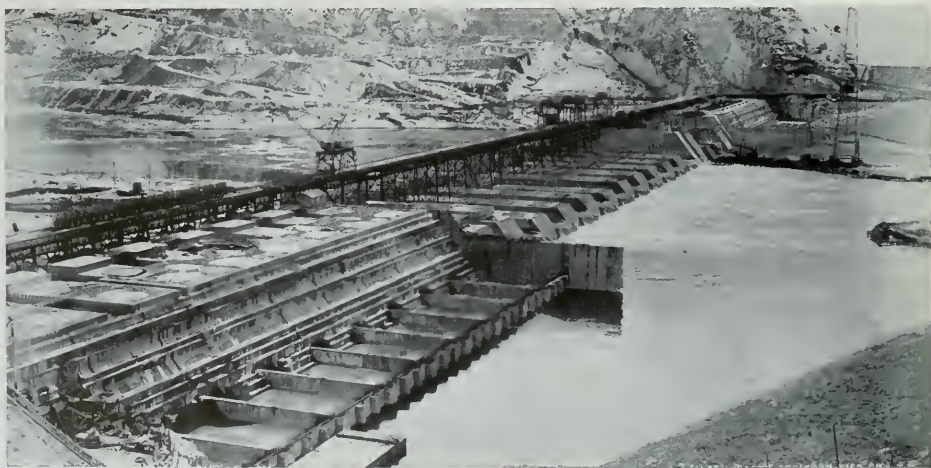

PROGRESS VIEW OF GRAND COULEE DAM

could connect the dam, the cells were 30 ft. in diameter by 80 ft. high. Where we had a cluster of cells which were to connect later at the Cross River Cofferdam, they were 80 to 100 feet in diameter.

It took us considerable time to get the 20,000 tons of sheet piling on the ground, and since it appeared that we must have this cofferdam completed within 90 days, and as we only had a limited number of rigs, which of course would only handle one hammer each, we devised a gantry frame to carry the steam hammers over the cells after the pilings were strated and on this frame we would hang six 9B3 hammers which ran on a trolley and in that way could proceed with the driving much faster. We were operating up to thirty-one hammers on this work and completed the cofferdam in 90 days—well ahead of the spring floods. This cofferdam, which took in about 40% of the base of the dam, when completed made it possible for us to excavate all the common excavation amounting to about 12 million yards on the west side of the river, with the exception of a berm which we left against the cofferdam, as we were afraid the cofferdam might shift, inasmuch as we had not yet driven the piling to bed rock. We drove this piling to refusal, but it was impossible to get them down through the glacier silt which was nearly as hard as the granite bed rock. Therefore, we were very much afraid that this cofferdam, as large as it was, might shift.

We left a major berm at the back of this cofferdam and went down to bed rock with a trench 60 feet wide and brought up a 50 foot block of concrete the full width of the dam. This acted as a brace against the cofferdam. This was very expensive as the bracing in this trench took over three million feet of lumber for heavy truss bracing. After this block of concrete was in, we removed all the berm that was left and uncovered the bedrock to the west abutment. We were then ready to go ahead with out bedrock excavation.

MILLION-DOLLAR GRAVEL PLANT

We had in the meantime built a gravel plant at an expense of one and one-quarter million

dollars. This was located on a hillside below the dam at a high elevation about one mile distant. This gravel plant was connected with large stock piles of aggregate at the dam site by a conveyor belt.

We had a very complete aggregate plant. The material was obtained on a level about 300 feet above the screening plant. This material was dug with four- and five-yard electric shovels, dumped into a hopper which deposited it onto a pendulum belt to the main belt line to be carried and dumped over the side of the hill in a large stock pile from which the material was drawn by feeders and taken on a belt through a tunnel to the sizing and crushing plant.

Here were two large Allis Chalmers Trunyon screens which retained all material over six inches. This was delivered to two gyratory crushers which reduced all the material to minus six inches. Then this material was delivered in a balancing pile about the top of the elevation of the main screening plant. From this stock pile, the material was taken by two conveyor belts into the screening plant which had double sets of screens for different sizes of aggregate.

After the four sizes of gravel are taken out, the residue goes to a rake dewaterer where all mud and water is removed and the clean sand taken by belt conveyor to the sand refining plant. Here three Dorr classifiers separate the sand into the three grades. From there it is taken by conveyor to three separate stock piles and from these separate stock piles the proper proportions are drawn and blended into a satisfactory sand.

This high grade sand produces a very exceptional concrete for mass work, with a minimum amount of cement. Our specifications called for 3,000 lb. concrete and our tests were from 5,000 to 5,500 pounds.

By this time we had also installed a mixing plant on each side of the river. The one on the west side of the river was connected with storage piles by a suspension bridge and carrying a 48" belt and conveying the aggregate across

the river for that plant. Each of these plants had four four-yard koring mixers with a Johnson batching system, and were capable of producing 9,000 yards each, every 24 hours. I am quite safe in saying that 15,820 yards in 24 hours, but either batch plant often produced over 9,000 yards per day. However, on account of not being able to get our placing trestle across the river, we were never able to get the full capacity of both plants.

ELECTRIC VIBRATORS FOR PLACING CONCRETE

From the mixing plant, the concrete was handled in four-yard buckets, four buckets on a car hauled by a Dieselectric locomotive. These concrete trains were run out on a steel trestle on which were three standard gauge tracks and under the Gantry hammerhead cranes and whirlies and the buckets were lowered below. The concrete generally was placed in 50-foot square blocks, and vibrated into place with electric vibrators. You must understand to maintain an average of from 12 to 15,000 yards per day, this was an unusual task, as there was on an average less than 500 cubic yards per block, which meant we had to have over 30 new blocks per day ready to pour.

To get a block ready to pour, there were about twenty items that had to be okayed by the inspectors or engineers before the block could be poured, including cleanup of previous concrete, cooling pipe, grouting pipe, copper water stops, etc. Inasmuch as we only had limited space in which to work on account of deep canyons (we found some which were not shown on the plans), we were not able to get our placing trestle connected across the river until a few weeks before the concrete was completed on our first contract.

It was a big job to keep the different crews lined up so as to have their work done in the proper blocks as these had to be kept in sequence, or the first thing you knew, we would be two-block.

Our greatest difficulty in proceeding with our contract for the base of this dam was the unexpected conditions that were encountered as we progressed with the work. For instance,

the plans showed one major canyon, but in the procedure of the work, we developed two other major canyons which was a very serious matter as we had to start the joints of our square blocks down in these canyons in the bedrock, some of which would be very small and inasmuch as we had height differential in blocks, it held us back a great deal getting out of these canyons. As I have said before, this kept us from getting our placing trestle connected across the river and we were never able to get full production out of both concrete plants. You must understand, with over 300 inspectors and engineers of the government, and with 6,000 men on our payroll, there was lots of room for confusion.

Going back to our river control, would say after we had about 40 per cent of the dam foundation constructed within the first cofferdam on the west side of the river, in which we had left a few blocks low, for diversion. We then put in two cross river cofferdams diverting the water through these blocks and leaving the balance of the dam foundation area under cofferdam. On this cross river cofferdam we used timber cribs built to profile of river bottom, floated them in place and sank these cribs by weight boxes. We then went up with our timber crib filling as we went with gravel to a one-to-one slope on the inside and drove a row of sheet piling on the water side of crib reinforced with a gravel berm.

STOP-LEAK PROCESS AVERTS CATASTROPHIES

All together, we could not expect much better luck with cofferdams than what we had, but we did have some very narrow escapes and at times, it looked as though we were close to a major disaster. One time, being after we had these cross river cofferdams in and had the hole unwatered, excavating bedrock, we had a leak from under one of the cylinders at the clusters and the hole was filled up very rapidly and to overcome this we placed a temporary outside berm and then made permanent repairs by doing a great deal of drilling and grouting and in some cases used a mixture of sawdust, shavings, cement and Bentonite.

We had several major slides in the construction of the Grand Coulee Dam foundation, inasmuch as the glacier top under laid the granite bedrock which was very unstable. This material would move under weight to about a six to one slope. In one instance, it became necessary for us to freeze a small canyon in the bedrock to hold back the hill which had broken for one-half mile back, and which would keep running into our excavation. This freezing process was very successful as we installed an ice plant with several miles of pipe in the sliding material and this section was frozen for a number of months while the excavation and concrete was being completed below.

The plant and equipment installed for building the foundation of the Grand Coulee Dam cost over ten million dollars. Much of this equipment was specially designed for the job.

375 DAYS AHEAD OF SCHEDULE

As I stated before, our original contract was for the completion to full height of a low dam, but about nine months after the contract was awarded, we received a change order to construct the foundation for the high dam. This increased our contract price over ten million dollars and lowered our profits considerably. When this change order was issued by the government, it stated that we would not be allowed any additional time on account of the large increase of work, but we not only completed the additional work, but finished our contract about 375 days ahead of original time allowed. Now had we been 375 days behind time, it would have cost us \$2,000 a day, or \$750,000.

But, of course, the government did not pay us any bonus for completing it 375 days ahead of time as their contract in this instance did not provide for a bonus. This year saving in time should eventually be worth to the government several million dollars a year in interest on investment.

The direction of the work was handled through an executive committee, composed of four members of the board of directors, under whom the job manager directed the work. The job manager on the first part of the work was Leslie Myer of the Silas Mason Company, and the last year and a half the job was handled by George H. Atkinson.

Our contract for the foundation of the dam was finished on March 21 of last year, and at that time the Consolidated Builders, Inc., took over the work under contract awarded to them on January 30 for approximately thirty-five million dollars for the completion of the dam. The Consolidated Builders, Inc., is composed of Mason-Walsh-Atkinson-Kier Company 50% and the other 50% is held by Henry J. Kaiser Co., Utah Construction Co., J. F. Shea Company, General Construction Co., McDonald & Kahn, Ltd., Morrisson Knudson Co., and Pacific Bridge Company.

This new contract is now well under way, the new corporation having installed a four-track trestle across the dam 170 feet higher than the original trestle. The present contract will be completed in from two to three years. It is being handled by Edgar F. Kaiser, job manager, and Clay Bedford, superintendent.

BUILDING INVESTMENT PROSPECTS

by Lloyd E. Graybiel

WE are living in complicated times. If it isn't the threat of war, it is the menace of inflation. I am not sure that anyone knows exactly where we are going. We do observe disturbing tendencies. We must return to one fundamental principle—that neither governments nor individuals can long continue to spend more than they take in and remain solvent.

Why am I speaking to you today? Because I represent a large banking institution which is keenly interested in the prosperity of the building industry. The bank thrives with the building industry and feels sick when that industry is inactive. Why? In the first place, building puts people to work. During the years 1920 to 1930, between 3,500,000 and 4,000,000 persons were employed in construction and allied lines; were earning money and spending those earnings on consumer goods. This creates widespread prosperity.

There is another aspect of the building industry which has not received sufficient attention—the part you play in creating permanent wealth of the nation. I believe your industry is the outstanding contributor. The Department of Commerce is authority for the statement that total construction activity, including maintenance, during 1920-1930 averaged 11.6 billion dollars annually. They estimate the permanent contribution to national wealth at 4.8 billion dollars per year, a total contribution of over 50 billion dollars during the decade.

Gentlemen, it took money to finance that contribution. This money represented accumulated savings of individuals and corporations. James Truslow Adams, the eminent historian, tells us that accumulated savings have created our national wealth and that additional wealth is dependent upon additional savings. We

must be constantly on the alert to resist those forces which seek to prevent accumulations of savings—whether in the hands of individuals or corporations—through excessive taxation or ill-advised attempts at redistribution. They represent a concrete menace to your industry.

There is another reason why banks are interested in an increased volume of new construction. Banks need good real estate loans to offset the decreased demand for commercial credit. In 1921, the member banks of the Federal Reserve System had 12.8 billion dollars in commercial loans. In 1937, commercial loans were over 5 billion dollars less. In 1929, these banks had 10.4 billion dollars loaned on securities, but by 1937, only 4.4 billion dollars.

These two classes of loans represented an aggregate shrinkage of 11 billion dollars, which is approximately the amount of the increase in the holdings of government bonds in 1936 over 1921. There is a vast amount of potential real estate loan credit available in the banks of the nation.

Some members of your profession speak hopefully of the coming boom in building. There is evidence of an accumulated shortage variously estimated in the neighborhood of a million homes. The total number of non-farm family units constructed in the years 1932-1937, inclusive, was only slightly in excess of those constructed in each of the years 1923-1926, inclusive. The credit is available to fill these needs under the lowest terms and easiest conditions in the history of home ownership in this country.

Shall we look at the other side of the picture? In the first place, the 20's left us with a large debt upon urban and suburban properties. Early in 1936, I endeavored to compute the percentage of this debt structure in relation to values and arrived at the startling conclusion

Editor's note—An address before the State Association of California Architects.

that it represented a first mortgage lien of approximately 60%. There was some shifting of debt through the operation of the H.O.L.C., but only an inconsequential reduction. The deflation of the debt structure, usually accomplished by depressions, was arrested through moratoriums and the creation of such agencies as the H.O.L.C.

Secondly, the rental index, using 100 to represent the year 1926, stood at 62 in 1933 but had recovered only to 84 in the first six months of 1938. This suggests that residential rents must become more attractive in order to encourage investment building.

Third, building costs are not far removed from the 1929 level. This suggests that the genius of the industry must be directed to improving the finished product through better methods of manufacture, distribution, and construction. Perhaps I should mention that I am fully aware of real progress in this direction already. However, there is much room for co-operative effort in the construction industry to meet consumer demand in competition with the other industries who are selling to him.

I am afraid that the word "prefabrication" is a naughty word with your profession, nevertheless facts must be faced. "Business Week" published a series of articles on the construction industry. Prefabrication was among the subjects discussed. Over fifty firms were listed, some of them very substantial, engaged in prefabrication of houses or component parts.

The architect must be an artist, but he must also be a business man. Today, individually and collectively, architects are challenged as never before to co-ordinate the implements of construction into a suitable finished product. His client's home should be suitable not only for residence, but also for sale if necessary. Unique houses are interesting to look at, but often difficult to move on the market. They have less loan value.

The architect must work toward a more stable product. Twenty-year financing contemplates at least twenty-year improvements. Stability of residence as well as of residential area has become of vital importance.

Your profession is charged with increased responsibility in these modern times. You are the co-ordinating factor between customer, lender and builder. These responsibilities are yours collectively and individually. I am inclined to think that each of us fails to realize his own responsibilities for good. I have had much comfort in the little bit of doggerel with which I close this talk.

Two frogs fell into a bucket of cream
And paddled to keep afloat;
But one soon tired and sank to rest
With a gurgling sigh in his throat.

The other paddled away all night
And not a croak did he utter;
And with the coming of morning light,
He rode on an island of butter.

The flies came thick to his island home
And made him a breakfast snappy.
The milkmaid shrieked and upset the pail,
And froggy hopped away happy.

The moral man finds in this little rhyme
And hastens at once to apply—
Success will come in the most difficult time
If you paddle and never say die.

BEING AN ARCHITECT IN 1939

By Wm. Orr Ludlow, A.I.A.

A GOOD deal is being said by architects about the sad estate into which the architect has fallen; we even hear suggestions that he is a supernumerary, that in this age, mechanized physically and spiritually, he has become just a "cog in the gears."

This somehow has a very familiar sound to me. I remember very well that shortly after I had started practice, a long time ago, I was planning, along with the rest of the architectural profession, how I could best fit into the builder's organization.

That same bogey has raised its head at well-measured intervals many times since, but nothing fearsome has happened and I question whether it ever will.

Nor do I believe that the architect is becoming a "cog in the gears," for when I look back

at the architect of the nineties and compare his position with that of the architect of today, I just know that he occupies a position today about a hundredfold more important than he did then.

And further, I am quite sure, that with the amazing number of new materials, new methods, new requirements, and new styles now at hand, the importance of the architect in the years immediately to come will be incomparably greater than in the decades just past, when the imitator, the copyist and the traditionalist could "get by."

Moreover, the profession never before numbered so many men who have the confidence and respect of the public, men who have been honored with positions of highest trust; and if we do not discourage the good men coming into architecture by what we say about it during bad times, we may look forward to even greater usefulness and fuller recognition.

Of course, the quickest way to arrive at the "cog" state is to say loudly and publicly that we are going to the dogs; so even if I thought that the dogs would get us, which I don't, I would just now keep rather quiet about such a disaster, and instead would point out to the depressionists that in my experience faith, not wailing; courage, not fear; counting of suc-

cesses, not failures—these have been the starting points of anything I have ever done that has been successful.

And here are a few of the reasons why I am glad that I am an architect in 1939:

Because, though the going has been heart-breaking, I can see the turn in the road.

Because there is great opportunity ahead; obsolescence, depreciation, new requirements and a country-wide underbuilt condition must soon be met with unprecedented building activity.

Because the architect will be needed more than ever before; he is the only one who can express new materials, new requirements and a new conception of art in terms of building.

Because I like the company of the kind of fellows that can be hit the hardest and complain the least.

Because architecture has turned from tradition and just started on a wonderful adventure. I want to go with it.

Because my profession is like my child, I love it because it is mine. I have given many of the hours of my life for it. It has hurt me, it has made me happy; we shall go on together to the end of the road.

TREND TOWARD GROUP PURCHASE OF HOMES

by Travis G. Walsh, Architect

THERE is an unmistakable national trend toward group purchase of homes, due to numerous interesting forces that are affecting domestic architecture today.

Architects at present are relating themselves not only to the orthodox demands connected with current residential building, but, perhaps for the first time in this country, the profession of architecture is definitely identified with sociological projects, low cost suburban developments, rural resettlement, or the more complex apartment structures such as are sponsored by the FHA. These activities are having an emotional influence on the work of architects nationally.

Chatham Village at Pittsburgh, so admirably planned by the late Henry Wright and his associates, was a forerunner of much of the multiple dwelling type of development that is in country-wide evidence today. With its direct relation to the severe grades so typical of Pittsburgh, and a simple expression of design reflecting the economy necessary to a sound financial return, these homes present incontestable evidence of the value of capable and talented architects.

Spurred by the fact that Chatham Village breasted the waves of depression with a one hundred per cent occupancy, a sound and uninterrupted financial return, the hard boiled business man has been inspired to go and do likewise.

This is not intended to be a tribute limited to the Pittsburgh project, since there are various effective developments throughout the country. It does give point, nevertheless, to an interesting fact: what has happened in Pittsburgh typifies a prevalent state of mind. An in-

creasing number of individuals interested in the "collective" type of development are approaching architects today. Mortality in large estates may have some bearing on this tendency. Decentralization is another factor.

Today the architect is frequently confronted with a young lawyer, bond salesman or doctor who, with four or five other friends, decides that an advantage exists in group purchase and construction. Perhaps they find a large estate is being partitioned, and for a nominal sum each individual may enjoy acreage rather than the customary city lot.

They are invariably convinced of the economies obtained in group construction, and generally agree on the value of a reputable architect establishing the quality of design and acting as the owner's agent in "policing" the building operation.

Federal encouragement and co-operation generally appears as a factor, since today more than at any time, the man in modern circumstances finds it possible to build his own home. Possibilities for this type of development naturally vary. If the construction is in a northern climate, logically the architecture is influenced by the fact.

Our pioneering ancestors discovered that well built wall sections, liberally punctuated with windows, brought about the pleasantest living conditions, and that a pitched roof is the best medium to resist heavy snows. This has promoted the popularity of the Georgian styles which, with numerous adaptations, have been used throughout the temperate zone.

When dwellings are a consideration, frequently the architect may draw from the Massachusetts precedent, as evidenced in the cot-

tages of Cape Cod, the garrison houses along the North Shore, or the more sophisticated Colonial examples to be found in Salem and Newburyport.

Pennsylvania also offers a charming prototype in the old stone farm houses of Bucks and Montgomery counties. The stonework, either natural or painted white, relieved by second story galleries, contributes individual factors to plan as well as elevation.

Maryland, Virginia and the Carolinas offer delightful examples of brick and frame architecture. Proof of this is rendered in the scholarly restoration of Colonial Williamsburg, Virginia, by Perry, Shaw & Hepburn of Boston. The influence of work such as that at Williamsburg is far reaching, and is bound to have an effect for years to come.

The deep South has reflected a more gentle climate with gracious facades characteristically supporting ornamental iron balconies such as are found in great profusion at the gulf ports of Mobile, Alabama, and New Orleans, Louisiana.

Florida, the Southwest and California were once colonies of Spain and the influence of the early settlers has enriched the architectural heritage of those sections. While the southern styles are not indigenous to other sections of the country, they are thoroughly logical and natural expressions in the areas of their origin.

Modernistic design is a medium which apparently recognizes neither climate nor neighborhood. When clients demand a home designed in the modern manner they generally have the "courage of their convictions" and it is clearly the obligation of a capable architect to clothe the owners' requirements. Some very attrac-

tive results are often obtained in this manner.

Naturally, with this lavish precedent, interesting possibilities develop which relate to interiors. The resources and skill of the millwork concerns are tested by architects in their demand for unusual woods and finishes, and their desire to obtain original effects. Furniture and all the multiple accessories which contribute to the gracious art of living, create fresh demands on the designers and retail trades.

Thus, the influence of New England architecture has brought about a distinct type of furniture manufacture, sufficiently important to justify large concerns limiting their output to a single style. The restoration of Colonial Williamsburg has likewise created keen interest in the "William and Mary" period, and the demands for modern interiors are taxing the creative instincts of all designers, in providing original ideas for practical elements.

These trends in design do not necessarily limit themselves to the factors described, but frequently influence the draperies, carpets, tableware, etc.

Apartment buildings, reflecting the more compact and sophisticated urges of city life, are also susceptible to the influences which have been described. This is particularly true with regard to interiors, where period or modernistic styles frequently are developed to include all the necessary matching details.

The various styles which have been outlined, indicate this rather interesting premise: probably nowhere else on earth has any country such a wealth and variety of styles in domestic architecture to draw upon, honestly typifying both background and climate.

WORLD'S LARGEST BELT CONVEYOR

Those who have read Mr. Atkins' interesting description of construction work at the Grand Coulee Dam, will find added interest in this brief story of the world's largest conveyor belt, in use at the dam. It marks a new volume in the history of mechanical conveying of materials by rubber belt.



PICTURE SHOWS LENGTH OF WORLD'S LARGEST CONVEYOR BELT IN USE AT GRAND COULEE DAM, WASHINGTON STATE

Operating on centers of 4,850 feet, the gigantic belt measures 9,700 feet long, approximately twice the length of the longest previous conveyor belt ever employed.

Of 48-inch width and eight-ply construction, this gargantuan belt was manufactured by the Goodyear Company in eight separate pieces weighing ten tons each to facilitate its handling and transportation, and shipped in rolls approximately ten feet in diameter. During installation the sections were vulcanized into one continuous endless belt weighing eighty tons.

A veritable "rubber railway," the completed belt required 30 tons of cotton and 50 tons of



EIGHT LAYERS OF COTTON FABRIC USED IN THE MANUFACTURE OF THIS 9,700 FT. GOODYEAR BELT

rubber for its manufacture. In action, the belt conveys coarse stone six-inch and minus, which will comprise the aggregate for the huge dam. Moving at a speed of 450 feet per minute the belt will carry the stone for an 11-minute ride, providing a flow of 2,000 tons per hour of aggregate required by the contractors for the project.

INVENTORY OF WPA ACCOMPLISHMENTS

The first detailed report concerned solely with the physical accomplishments of the Works Progress Administration is off the press—a 100-page, illustrated booklet which summarizes the contribution to civic progress of the Federal Works Program through which the Government has coped with the problem of unemployment.

Published by the Government Printing Office under the title "Inventory: An Appraisal of the Works Progress Administration," the booklet is available for sale by the Superintendent of Documents, Washington, D. C., at the nominal price of 30 cents. Concisely, but comprehensively, the Inventory traces the economic jolts which made a Federal relief program necessary, and the development of the program through the Federal Emergency Relief Administration, the Civil Works Administration, and finally, the W. P. A.

GOLDEN GATE CEMENTS AT TREASURE ISLAND

THE march of progress, illustrating Portland cement manufacture and its applications, is presented by the Pacific Portland Cement Company at the Golden Gate Exposition in the mining division of Treasure Island.

The simple, even crude, method of crushing cement rock with horse-driven burr stones is portrayed in the mural of the background and the burning process which converts the lime and clay materials into Portland cement is illustrated by the primitive lime kiln which was still in use in the United States until 1892.

In contrast to this crude process, the mural presents a broadside of a modern cement manufacturing plant equipped with its massive grinding machines in each of which 50 tons of steel balls perform the crushing operation and where rotary kilns 240 feet long, 11 feet in diameter, weighing 300 tons each, calcine the materials into Portland cement clinker.

This story is beautifully told with moving colored pictures and presents all the essentials in manufacture, giving it a deserved educational value.

The application of Portland cement in the practical construction field is illustrated by the miniature wheelbarrows of rock, sand and cement, which are mixed with water in a miniature concrete mixer. This produces the plastic mass of concrete to be shaped into the desired forms of foundations, walls, pipe, building blocks and stucco.

Hardwall gypsum plaster specimens are illustrated with sections of a Sierra partition and wall tile which has exceptional fireproof properties and is used to build up wall sections economically. In addition, a plaster panel shows the three coats of interior hard-wall gypsum plaster so universally specified in the best types of interior wall construction.

The use of steel embedded in concrete is well presented to show the almost inseparable requirement of steel rods running through the concrete to confer additional strength and resistance.

The artistic development of attractive color effects in concrete slabs is prominently presented by several plaques, representing inlays of fish and reeds in a yellow background. An almost black plaque, made of Portland cement and selected colored rock materials, represents the exact material used in the making of the huge black whale fountain in the San Francisco Building, which is declared a monument of artistic creation at the World's Fair.

Various types of Portland cement are shown in trays, including regular Portland cement, Tan cement, 24-hour cement, Sewater cement and Oilwell cement, all of which are Golden Gate brands of the finest quality.

Any information desired regarding this exhibit, or the types and special uses of any of the Golden Gate cements displayed, will be gladly furnished by the Pacific Portland Cement Company upon request.

PAYMENT FOR PLANS AND SPECIFICATIONS

The national office of the Associated General Contractors of America, Inc., was recently advised by one of their chapters that in connection with the construction of certain P.W.A. non-Federal projects, the general contractor had been required to purchase from the architect sets of plans and specifications needed to prosecute the work.

The facts were submitted to officials of the Public Works Administration with the request that such practice be prohibited, inasmuch as the costs of plans and specifications necessary for use by the general contractor constituted a fair and proper charge payable by the owner.

The Public Works Administration has instructed its regional directors that the cost of plans and specifications necessary for use in the construction of any P.W.A. project is to be construed as a part of the job cost and must be paid for by the owner, and that contractors shall not, under any circumstances, be required to pay for such plans and specifications as may be needed in prosecuting their work.

The P.W.A. headquarters recommended that violations of this ruling be reported to the appropriate regional P.W.A. office in such cases where such violations cannot be settled locally.

SEATTLE HONOR AWARDS

To encourage the appreciation of architecture by extending its recognition of exceptional merit in executed work, Washington State Chapter, A.I.A., has adopted the "honor award" plan. These certificates of honor will be given to the architect, owner, and to such contractors as a jury shall nominate as having contributed most to good architecture and construction.

Approximately fifty entries for the honor awards are being shown at the exhibition in the Seattle Art Museum. The judges are Leonard W. Bindon, Bellingham; Roi L. Morin, Portland; and Ernest T. Mock, Tacoma.

CERTIFICATE TO PRACTICE

The office of the California State Board of Architectural Examiners, Northern District, is now at 515 Van Ness Avenue, San Francisco. Harry Devine is president and Frederick H. Reimers is secretary. At the January meeting of the Board a provisional certificate was granted to Keplar B. Johnson, 6300 Broadway Terrace, Oakland.

ICE SKATING BENEATH A TORRID SUN



SOUTHERN CALIFORNIA'S LATEST RECREATION SPOT—MADE POSSIBLE BY USING NATURAL GAS AS FUEL FOR DRIVING AMMONIA COMPRESSOR UNITS

SOMETHING new under the Southern California sun is the "Tropical Ice Garden," a year 'round outdoor skating rink, in Westwood Village, ten miles west of Los Angeles. That it is not a midwinter night's dream, and will prove soundly engineered and quite practicable, seems assured. It has been open and operating since November 28 and already, thanks to the usual unusual weather of early December, when the official thermometer in Los Angeles reached 92 degrees, the refrigeration system's ability to maintain ice under adverse conditions has received a thorough test.

One day recently, when the beaches, customarily deserted at this season, were crowded with people seeking refuge from the inland heat, Herman Vetter, refrigeration engineer, who installed the plant, checked temperatures in and above the ice. The ice itself registered 28 deg. F.; one foot above, the temperature was 100 deg. F.; and at two feet the temperature was 124 deg. F. He concluded, with apparent justification, that they would be able to hold the ice during the summer.

The project represents a bold departure from past artificial refrigeration practice, yet no new principles are involved. Anhydrous ammonia and brine, handled in the conventional way, are employed as refrigerants. The brine, however, is not injected into the usual network of pipes laid over the floor. It is collected in a 12-inch header which runs along one side of the rink, and distributed into a series of cells, four feet wide and the width of the rink long. These are made of steel

plates and laid so as to form a continuous surface over the whole area of the rink, bringing the entire body of the ice in direct contact with the refrigerating surface all of the time.

Natural gas engines were chosen to furnish power for the ammonia compressor units. Year-around operation makes fuel economy very necessary, and natural gas was selected for that reason. The units consist of two Western straight line 200 h.p. twin horizontal engines, directly connected to Worthington 10" x 20" ammonia compressor cylinders. Each unit has a capacity of 182 tons of refrigeration at 25 lbs. per square inch suction and 155 lbs. per square inch discharge pressures.

The problem of vibration, which would have been objectionable, was solved by pouring the reinforced common foundation of the engines to approximately twice the normal depth. Engine mufflers were specially designed and installed to eliminate exhaust sound. The silencers consist of two individual concrete-lined rock-filled pits through which the exhaust pipe extends into a four-foot expansion chamber. The exhaust pipe within the rock-filled pit is slotted to provide openings equal to $1\frac{1}{2}$ times the cross-sectional area of the pipe. Exhaust gases are conducted to the atmosphere through a riser pipe from the expansion chamber.

A hill which rises steeply on the west side of the rink was terraced to provide seating arrangements for an audience of 10,000 people.

Proposed Constitution of Structural Engineers

THE following is a copy of the proposed constitution of the Structural Engineers Association of California, as recommended for adoption by the Professional Activities and Welfare Committee of the Northern Association:

I. DEFINITION OF TERMS

Whenever in this document the following terms or pronouns in place of them are used, the meaning shall be as follows:

Northern Association—The Structural Engineers Association of Northern California.

Southern Association—The Structural Engineers Association of Southern California.

Associations—The Structural Engineers Association of Northern California and the Structural Engineers Association of Southern California.

II. NAME

The name of this organization shall be the **Structural Engineers Association of California**.

III. PURPOSE

The purpose of this organization shall be:

1. To promote friendly understanding and unity of action between the Northern and Southern Association.

2. To provide a medium for concentration of effort to further those policies that have been approved by both the Northern Association and the Southern Association.

IV. MEMBERSHIP

Every member in good standing of the Northern Association or the Southern Association shall be a member in good standing of this organization.

V. DIRECTION

1. Direction of this organization shall be vested in a Board of Directors. This Board shall consist of four (4) members who shall be the presidents and latest available past presidents of the two Associations.

2. A vacancy in the Board of Directors shall be filled by that Association whose member held the position vacated.

VI. TERM OF OFFICE

The members of the Board of Directors shall take office at the adjournment of the annual convention of the organization. Except that the past presidents first serving after the adoption of this constitution shall serve until the adjournment of the next annual convention, all members of the Board shall serve for two years.

VII. OFFICERS

1. The officers of the organization shall be a President, a Vice-President, and a Secretary-Treasurer.

2. The Board of Directors shall annually elect the officers for the ensuing year from the members of the Board at the annual convention. During the first two years after the adoption of this constitution and during alternate two-yearly periods thereafter, the office of President shall be filled by a member from the Southern Association; at other times the office shall be filled by a member of the Northern Association. When the President is a member of the Southern Association, the Vice-President and Secretary-Treasurer shall be members of the Northern Association, and vice versa.

VIII. DUTIES OF DIRECTORS

1. The Board of Directors shall administer the affairs of the organization in conformity with the provisions of Article III and shall submit a report at the annual convention.

2. All members of the Board, including the President, shall vote and a majority shall govern. Three members shall constitute a quorum.

IX. REVENUES

1. No dues shall be assessed against individual members.

2. Each Association shall pay annually into the treasury of this organization the sum of fifty cents (50¢) for each of its members in good standing.

3. The Board of Directors may solicit and receive additional funds for special purposes from the Association in proportion to their membership in good standing.

4. The retiring Treasurer shall turn over any unexpended funds to his successor.

X. AMENDMENTS

1. Amendment or repeal of this Constitution may be proposed at any meeting of either Association.

2. Voting on proposed amendment or repeal shall be by letter ballot. Ballots shall be furnished to all members of the Northern and Southern Associations by the respective Secretaries.

3. An affirmative vote of not less than two-thirds of the total votes cast by the members of each Association, considered separately, and a total vote of not less than a majority of the members in each Association, considered separately, shall be required to amend or repeal this Constitution.

XI. MEETINGS

An annual convention of the organization shall be held. The Board of Directors shall fix the time and place and shall make all other arrangements for this convention.

ANDREW LEAVES PURCELL

Charles E. Andrew, principal bridge engineer of the San Francisco-Oakland Bay Bridge, has tendered his resignation to accept a two-year contract as director of design and construction of the Narrows Bridge at Tacoma, and Lake Washington Bridge, Seattle.

Mr. Andrew will serve as principal consulting engineer and chairman of the consulting board in charge of construction and design for two Washington State bridges. These are the \$6,500,000 Narrows Bridge at Tacoma and the Lake Washington Bridge, an \$8,500,000 structure, at Seattle.

Mr. Andrew has served with the California State Department of Public Works, under civil service, since 1927—first as bridge engineer for the Division of Highways and then as bridge engineer for the San Francisco-Oakland Bay Bridge, in direct charge of construction, operation, and maintenance. He was in immediate charge of plans, designs, and boring operation for the 1929 Hoover-Young report on the Bay Bridge, basis of actual bridge construction.

ARTHUR S. BENT

Arthur S. Bent, nationally known construction leader and active for many years in civic and business affairs in Los Angeles, passed away February 17 at his home, 620 Siena Way, Bel-Air, after an illness of two weeks.

Mr. Bent was born in Downieville, California, April 25, 1863, the son of H. K. W. Bent and Jessie Crawford Bent. His father was one of the founders and a trustee of Pomona College, and on the latter's death, twenty years ago, the son succeeded to the office of trustee which he had held continuously since. Arthur S. Bent was educated in the Los Angeles public schools and immediately embarked in the construction business in which he was engaged for more than fifty years, founding the firm of Bent Bros., Inc., of which he was the active head until his death.

With the Architects

ARCHITECT'S GOLDEN JUBILEE

Friends of B. J. S. Cahill architect of Oakland and Alameda, will be interested to know that this year marks his 50th anniversary of continuous architectural practice in California. Mr. Cahill was at one time associated with Geo. Rushforth and Wright as Wright, Rushforth & Cahill. In recent years his work has been largely mausoleums and crematories. Many years ago he designed the Multnomah Hotel in Portland, Oregon. He claims to have been the originator of the San Francisco Civic Center. He designed the now famous Butterfly map of the world. Mr. Cahill has promised to write his impressions of the Treasure Island Exposition in an early issue of *The Architect and Engineer*.

1939 INSTITUTE CONVENTION

The Seventy-first Annual Convention of The American Institute of Architects will be held in Washington, D. C., September 24-28. The Fifteenth International Congress of Architects will be held in Washington at the same time with sessions that parallel or merge with meetings of the Institute. The distinguished foreign architects will join with the American architects in a trip to Williamsburg by steamer and in a trip by special train to the New York Fair. Monday, October 2 has been designated as "Architects Day" at the Fair.

FURNITURE STORE BUILDINGS

From plans by Guy O. Goepf, 117 Church Street, Salinas, the Geo. Genser Furniture Company will build a one story reinforced concrete furniture store building at South Main and John Streets, Salinas. The building will cover ground area 55x190 feet and will be equipped with a fire sprinkler system. The same architect has completed drawings for a similar type building in Santa Cruz for the Eastern Furniture Company.

HOSPITAL ADDITIONS

Additions are planned to two Northern California hospitals. W. G. Corlett of Oakland is preparing plans for a four story reinforced concrete 80 bed addition to the Palo Alto Hospital and N. W. Sexton of San Francisco, has started preliminary drawings for ten rooms and two 3 bed wards at the Ross General Hospital, Ross, Marin County.

STORE BUILDING REMODEL

O. A. Deichmann, 321 Bush Street, has completed plans and specifications for a \$90,000 modernization project for the National Dollar Stores, Ltd., at 929 Market Street, San Francisco. Both the exteriors and interiors of the two buildings, one a four story structure and the other two, will be extensively remodeled.

ALAMEDA COUNTY RESIDENCES

Irwin M. Johnson, 1131 Harvard Road, Oakland, has completed plans for two residences, one for H. L. Cook in San Leandro to cost \$7,000 and the other in Piedmont for Harold N. Chesebrough costing \$10,000. Contracts for both houses have been let and construction has started.

C. N. HILBURN BUSY

New work in the office of C. N. Hilburn of Modesto includes a nine room house in Turlock for Dr. M. C. Collins, to cost \$15,000, of frame and brick veneer construction with copper roof and a \$10,000 dwelling for E. C. Evers in Modesto.

COUNTRY CLUB ADDITION

Plans have been completed for a \$12,000 addition to the Lake Merced Golf and Country Club, San Francisco. Albert F. Roller of San Francisco is architect for the improvements. Mr. Roller also has plans under way for remodeling the Santa Fe ticket office at 235 Geary Street, San Francisco.

HASSLER HEALTH FARM

Plans are complete for various units of the Hassler Health Farm near Redwood City for the City and County of San Francisco. Dodge A. Riedy, City Architect, will supervise the work which includes a children's building, designed by John Bakewell, Jr.

BUSY ON RESIDENCE WORK

Albert Larson, 333 Kearny Street, San Francisco, is busy on residence designs, including two houses on Charter Oaks Street for A. Romagnolo and two houses on Ashton Avenue, Millbrae, for John Johnson.

MASONIC TEMPLE

Ernest J. Kump, Sr., Rowell Building, Fresno, has completed drawings for a \$20,000 Masonic Temple at Madera. Bids have been taken and construction will start immediately.

STADIUM TYPE THEATER

Vincent Raney, 233 Post Street, San Francisco, has designed a stadium type theater to seat 650 persons for Salinas. Construction will be of reinforced concrete with wood roof trusses and two stores. The estimated cost is \$40,000.

OPENS SPOKANE OFFICE

Kenneth D. Stormont, formerly with George M. Rasque, state architect, recently was issued a license and has opened an office at 725 Hutton Building, Spokane.

AQUA THERM

AUTOMATIC STORAGE TYPE

OIL BURNING WATER HEATER



by
H. C. Little

BURNER CO.
San Rafael, California
DESIGNERS AND MAKERS OF
COMPLETE OIL BURNING
EQUIPMENT

ECONOMICAL — DEPENDABLE
30 GALLON STORAGE CAPACITY
40 GALLON PER HOUR RECOVERY
ELECTRIC THERMOSTAT
CONTROL
NO PILOT LIGHT TO WORRY
ABOUT
BURNS CHEAP FURNACE OIL

For all-around comfort and economy
... match with H. C. LITTLE OIL
BURNING FURNACE.

MODERN ARCHITECTURE ABROAD

Dr. S. Giedion, general secretary of the International Congress for the Promotion of Modern Buildings, with headquarters in Zurich, Switzerland, is visiting American cities. While in this country, he is giving a course of lectures at Harvard University on modern architecture in Europe. He is particularly interested in the subject of town planning and is making a study of conditions in various American cities. His work at Harvard, under the Charles Eliot Norton Fellowship, will continue for the present academic year and the results thereafter will be published by the Harvard University Press.

Bad town planning, Dr. Giedion says, is worse than no town planning and he believes that there is a wonderful opportunity for some of our wealthy public-spirited citizens to get behind such a movement, which he believes is the keystone of every culture.

Modern architecture does not impress Dr. Giedion because it is modern, but because, in it, he sees the symbol of projection of modern thinking.

N. CLARK & SONS' NEW REPRESENTATIVE

Pacific Clay Products, located at 306 West Avenue 26, Los Angeles, California, has been appointed sales representative in Southern California and Arizona of N. Clark & Sons, pioneer Pacific Coast manufacturers of quality clay products. Pacific Clay Products is prepared to render architects, engineers, building contractors and owners full technical advice in the selection, use and prices of all forms of architectural terra cotta, i.e. handmade terra cotta, ceramic veneer, unglazed terra cotta wall units and quarry tile.

CALIFORNIA COLONIAL RESIDENCE

Edwin L. Snyder has completed plans and contracts have been let for a 14 room California Colonial residence in the Arlington Villa Tract for E. N. Cororan. The exterior will be brick veneer with shingle roof, steel sash and hot air heating.

Mr. Snyder has just finished plans for a seven room dwelling and guest house at Carmel for an unnamed client. Mr. Snyder plans to build a home for himself at Carmel in the not distant future.

HOUSES BY GOODMAN

Michael Goodman, architect of Berkeley, has moved to 2121 Allston Way, Berkeley, one block south of his former location. Mr. Goodman has been doing some creditable designing in small houses the past year or two and it is planned to show some of this work in an early issue of Architect and Engineer.

HIGH SCHOOL IMPROVEMENTS

The Nevada City High School will undergo extensive remodeling this summer from plans by William Mooser, 244 Kearny Street, San Francisco. About \$20,000 will be expended for manual training shops, auditorium stage, etc.

No Worry for the Architect

"—All acid proof drain pipe and fittings shall be ferrosilicon—CORROSIRON—"

[Write for this specification]



FEDERAL BUILDING • CIVIC CENTER • SAN FRANCISCO

Arthur Brown, Jr., Architect

CORROSIRON DRAIN LINES and FITTINGS and LABORATORY EQUIPMENT was specified because of its superior resistance to corrosion and wear.

Pacific Foundry Company, Ltd.

NEW YORK • 3100 NINETEENTH ST., SAN FRANCISCO • LOS ANGELES

Estimator's Guide

Giving Cost of Building Materials, Wage Scale, Etc.

Amounts given are figuring prices and are made up from average quotations furnished by material houses to San Francisco contractors. 3% Sales Tax on all materials but not labor.

All prices and wages quoted are for San Francisco and the Bay District. There may be slight fluctuation of prices in the interior and southern part of the state. Freight cartage, at least, must be added in figuring country work.

Bond— $1\frac{1}{2}\%$ amount of contract.

Brickwork—

Common. \$40 to \$45 per 1000 laid, (according to class of work).

Face, \$100 to \$110 per 1000 laid, (according to class of work).

Brick Steps, using pressed brick, \$1.25 lin. ft.

Brick Veneer on frame buildings, \$.75 sq. ft.

Common f.o.b. cars, \$14.00 at yard. Cartage extra.

Face, f.o.b. cars, \$45.00 to \$50.00 per 1000. carload lots.

HOLLOW TILE FIREPROOFING (f.o.b. job)

3x12x12 in.	\$ 84.00 per M
4x12x12 in.	94.50 per M
6x12x12 in.	126.00 per M
8x12x12 in.	225.00 per M

HOLLOW BUILDING TILE (f.o.b. job)

carload lots.	
8x12x5 $\frac{1}{2}$	\$ 94.50
6x12x5 $\frac{1}{2}$	73.50

Building Paper—

1 ply per 1000 ft. roll	\$3.50
2 ply per 1000 ft. roll	5.00
3 ply per 1000 ft. roll	6.25
Brownskin, 500 ft. roll	4.50
Brownskin, Pro-foct-a-mat, 1000 ft. roll.....	9.00
Sisalraft, 500 ft. roll	5.00
5ash cord com. No. 7	\$1.20 per 100 ft.
Sash cord com. No. 8	1.50 per 100 ft.
Sash cord spot No. 7	1.90 per 100 ft.
Sash cord spot No. 8	2.25 per 100 ft.
5ash weights cast iron, \$50.00 ton.	
Nails, \$3.50 base.	
Sash weights, \$45 per ton.	

Concrete Aggregates—

Gravel (all sizes) \$1.45 per ton at bunker; delivered to any point in S. F. County \$1.85.

	Bunker	Delivered
Top sand	\$1.45	\$1.85
Concrete mix	1.45	1.85
Crushed rock, $\frac{1}{4}$ to $\frac{3}{4}$	1.60	2.00
Crushed rock, $\frac{3}{4}$ to 1 $\frac{1}{2}$	1.60	2.00
Roofing gravel	1.60	2.00
City gravel	1.45	1.85
River sand	1.40	1.80
Delivered bank sand—\$1.00 per cubic yard at bunker or delivered.		

SAND—

	Bunker	Delivered
R-ver sand	\$1.40	\$1.80
Lapis (Nos. 2 & 4)	2.00	2.40
Olympia Nos. 1 & 2	1.80	2.20
Healdsburg plaster sand	\$1.80 and \$2.20	
Del Monte white	50c per sack	

CEMENT (all brands, cloth sacks) \$2.72 per bbl.; f.o.b. car; deliv. \$2.90 per bbl.; carload lots; less than carload lots, warehouse or delivered; 8% per sack. (Less 10c per sack returned, 2% 10th Prox.)

Common cement (all brands, paper sacks) carload lots \$2.52 per bbl.; f.o.b. car; delivered; \$2.70; less than carloads delivered, 75c per sack. Discount on cloth sacks, 10c per sack. Cash discount on carload lots, 10c a barrel, 10th Prox.; cash discount less than carload lots, 2%.

Atlas White } (1 to 100 sacks, \$1.50 sack,
Calaveras White } warehouse or delivery; over 100
Medusa White } sacks, \$1.25; 2% discount 10th
of month.

Forms, Labors average \$40.00 per M.

Average cost of concrete in place, exclusive of forms, 35c per cu. ft.; with forms, 60c.

4-inch concrete basement floor

.....12 $\frac{1}{2}$ c to 14c per sq. ft.

Rat-proofing

Concrete Steps

.....\$1.25 per lin. ft.

Dampproofing and Waterproofing—

Two-coat work, 20c per yard.

Membrane waterproofing—4 layers of saturated felt, \$4.50 per square.

Hot coating work, \$1.80 per square.

Medusa Waterproofing, 15c per lb., San Francisco Warehouse.

Tricocel waterproofing.

(See representative.)

Electric Wiring—\$12.00 to \$15.00 per outlet

for conduit work (including switches).

Knob and tube average \$3.50 per outlet.

Elevators—

Prices vary according to capacity, speed and type. Consult elevator companies. Average cost of installing an automatic elevator in four-story building, \$2800; direct automatic, about \$2700.

Excavation—

Sand, 60 cents; clay or shale \$1 per yard.

Teams, \$12.00 per day.

Trucks, \$22 to \$27.50 per day.

Above figures are an average without water. Steam shovel work in large quantities, less; hard material, such as rock, will run considerably more.

Fire Escapes—

Ten-foot galvanized iron balcony, with stairs, \$115 installed on new buildings; \$140 on old buildings.

Floors—

Composition Floors—22c to 40c per sq. ft.

In large quantities, 16c per sq. ft. laid.

Mosaic Floors—80c per sq. ft.

Duraflex Floor—23c to 30c per sq. ft.

Rubber Tile—50c to 75c per sq. ft.

Terazzo Floors—45c to 60c per sq. ft.

Terazzo Steps—\$1.60 lin. ft.

Hardwood Flooring (delivered to building)—

$1\frac{1}{2}$ x 2 $\frac{1}{4}$ " T & G Maple

.....\$ 88.00 M ft.

$1\frac{1}{2}$ x 2 $\frac{1}{4}$ " T & G Maple

.....115.00 M ft.

$\frac{7}{8}$ x 3 $\frac{1}{2}$ " T & G edge Maple

.....100.00 M ft.

	$1\frac{1}{2}$ x 2 $\frac{1}{4}$ "	3 $\frac{1}{2}$ x 3"	$\frac{3}{4}$ x 2"
	T & G	T & G	Sq. Ed.
Cir. Old, Oak	\$120.00 M	\$ 82.50 M	\$110 M
Sel. Old, Oak	99.00 M	69.50 M	84 M
Cir. Pla. Oak	106.00 M	74.50 M	86 M
Sel. Pla. Oak	97.00 M	62.50 M	76 M
Clear Maple	111.00 M	100.00 M	
Laying & Finishing	14c ft.	12c ft.	10c ft.
Wage—Floor layers, \$10.00.			

Note—Above quotations are all board measure except last column which is sq. ft.

Glass (consult with manufacturers)—

Double strength window glass, 20c per square foot.

Plate 75c per square foot (unglazed) in place, \$1.00.

Art. \$1.00 up per square foot.

Wire (for skylights), 40c per sq. foot.

Obscure glass, 30c square foot.

Glass bricks, \$2.40 per sq. ft., in place.

Note—If not stipulated add extra for setting.

Heating—

Average, \$1.90 per sq. ft. of radiation, according to conditions.

Warm air (gravity) average \$40 per register.

Forced air, average \$60 per register.

Iron—Cost of ornamental iron, cast iron,

etc., depends on designs.

Lumber (prices delivered to bldg. site).

No. 1 common	\$29.00 per M
No. 2 common	27.00 per M
Select O. P. common	34.00 per M
2x4 No. 3 form lumber	24.00 per M
1x4 No. 2 flooring VG	55.00 per M
1x4 No. 3 flooring VG	47.00 per M
1x6 No. 2 flooring VG	60.00 per M
1 $\frac{1}{4}$ x 4 and 6, No. 2 flooring	60.00 per M

Slash grain—

1x4 No. 2 flooring	\$43.00 per M
1x4 No. 3 flooring	40.00 per M
No. 1, common run T. & G.	30.00 per M
Lath	5.25 per M

Shingles (add cartage to price quoted)—

Redwood, No. 1	\$1.10 per bble.
Redwood, No. 290 per bble.
Red Cedar	1.10 per bble.

Plywood—Douglas Fir (ad cartage)—

"Plyscord" sheathing (unsanded)

5 $\frac{1}{16}$ " 3-ply and 48"x96"

.....\$30.00 per M

Wallboard Grade (sound one side)

$\frac{1}{4}$ " 3-ply, 48"x96"

.....\$37.50 per M

Concrete Form Panels (special core & glue)

3 $\frac{1}{2}$ " 5-ply 48"x96"

.....\$110.00 per M

If tiled,

.....\$5.00 extra per M

Millwork—Standard.

O. P. \$85.00 per 1000. R. W., \$90.00 per 1000 (delivered).

Double hung box window frames, average with trim, \$6.50 and up, each.

Doors, including trim (single panel, 1 $\frac{1}{4}$ in. Oregon pine) \$8.00 and up, each.

Doors, including trim (five panel, 1 $\frac{1}{4}$ in. Oregon pine) \$6.00 each.

Screen doors, \$3.50 each.

Patent screen windows, 25c a sq. ft.

Cases for kitchen pantries seven ft. high per lineal ft., \$8.00 each.

Dining room cases, \$8.00 per lineal foot Rough and finish about 75c per sq. ft.

Labor—Rough carpentry, warehouse heavy framing (average), \$17.50 per M.

For smaller work average, \$35.00 to \$45.00 per 1000.

Merble—(See Dealers)

Painting—

Two-coat work	36c per yard
Three-coat work	50c per yard
Cold Water Painting.....	10c per yard
Whitewashing	4c per yard
Turpentine, 65c per gal., in 5 gal. cans, and 55c per gal. in drums.	
Raw Linseed Oil—97c gal. in bbls.	
Boiled Linseed Oil—\$1.00 gal. in bbls.	
Medusa Portland Cement Paint, 20c per lb.	

Pioneer or Dutch Boy White Lead in Oil (in steel kegs).

	Per Lb.
1 ton lots, 100 lbs. net weight.....	10/4c
500 lbs. and less than 1 ton lots.....	10/2c
Less than 500 lb. lots.....	11c

Pioneer or Dutch Boy Red Lead and Litharge (in steel kegs).

1 ton lots, 100 lb. kegs, net weight.....	10/4c
500 lbs. and less than 1 ton lots.....	10/2c
Less than 500 lb. lots.....	11c

Pioneer Red Lead in Oil (in steel kegs)

1 ton lots, 100 lb. kegs, net weight.....	11/2c
500 lbs. and less than 1 ton lots.....	11/2c
Less than 500 lb. lots.....	12c

Note—Accessibility and conditions cause some variance in costs.

Patent Chimneys—

6-inch	\$1.25 lineal foot
8-inch	1.75 lineal foot
10-inch	2.25 lineal foot
12-inch	3.00 lineal foot

Plastering—Interior—

	Yard
1 coat, brown mortar only, wood lath.....	\$0.75
2 coats, lime mortar, hard finish, wood lath.....	.80
2 coats, hard wall plaster, wood lath.....	.85
3 coats, metal lath and plaster.....	1.50
Keene cement on metal lath	1.60
Ceilings with 3/4 hot roll channels metal lath90

Ceilings with 3/4 hot roll channels metal lath plastered.....	1.65
Single partition 3/4 channel lath 1 side.....	.85
Single partition 3/4 channel lath 2 sides 2 inches thick	1.50
4-inch double partition 3/4 channel lath 2 sides	1.30
4-inch double partition 3/4 channel lath 2 sides plastered	3.00

Plastering—Exterior—

2 coats cement finish, brick or concrete wall	1.00
2 coats Calaveras cement, brick or concrete wall	1.35
3 coats cement finish, No. 18 gauge wire mesh	1.50
3 coats Calaveras white finish, No. 18 gauge wire mesh	1.75

Wood lath, \$7.50 to \$8.00 per 1000.	
2.5-lb. metal lath (dipped)17
2.5-lb. metal lath (galvanized)20
3.4-lb. metal lath (dipped)22
3.4-lb. metal lath (galvanized)28
3/4-inch hot roll channels, \$72 per ton.	
Finish plaster, \$18.00 ton; in paper sacks.	
Dealers' commission, \$1.00 off above quotations.	
\$13.85 (rebate 10c sack).	
Lime, f.o.b. warehouse, \$2.25 bbl.; cars, \$2.15	
Lime, bulk (ton 2000 lbs.), \$50.00 per M.	
Hydrate Lime, \$19.50 ton.	

Plasterers' Wage Scale \$1.25 per hour

Lathers' Wage Scale 1.25 per hour

Hod Carriers' Wage Scale 1.10 per hour

Composition Stucco—\$1.60 to \$2.00 sq. yard (applied).

Plumbing—

From \$70.00 per fixture up, according to grade, quantity and runs.

Roofing—

"Standard" tar and gravel, \$6.50 per sq. for 30 sqs. or over.
 Less than 30 sqs. \$7.00 per sq.
 Tile, \$20.00 to \$35.00 per square.
 Redwood Shingles, \$7.50 per square in place.
 Copper, \$16.50 to \$18.00 per sq. in place.
 Cedar Shingles, \$8.00 per sq. in place.
 Recoat with Gravel, \$3.00 per sq.
 Asbestos Shingles, \$15 to \$25 per sq. laid.

Slate, from \$25.00 to \$60.00 per sq. yard, according to color and thickness.
 Shakes—1x25" resawn \$11.50 per sq.
 1/2x25" resawn 10.50 per sq.
 1/2x25" tapered 10.00 per sq.
 Above prices are for shakes in place.

Sheet Metal—

Windows—Metal, \$1.75 a sq. foot.
 Fire doors (average), including hardware \$1.75 per sq. ft.

Skylights—(not glazed)

Copper, 90c sq. ft. (flat).
 Galvanized iron, 30c sq. ft. (flat).
 Vented hip skylights 60c sq. ft.

Steel—Structural

\$120 ton (erected), this quotation is an average for comparatively small quantities. Light truss work higher. Plain beams and column work in large quantities \$90 to \$100 per ton.

Steel Reinforcing—

\$80.00 to \$120.00 per ton, set.

Stone—

Granite, average, \$6.50 cu. foot in place.
 Sandstone, average Blue, \$4.00, Boise, \$3.00 sq. ft. in place.

Indiana Limestone, \$2.80 per sq. ft. in place.

Store Fronts—

Copper sash bars for store fronts, corner center and around sides, will average 75c per lineal foot.

Note—Consult with agents.

Tile—Floor, Wainscot, etc.—(See Dealers)

Asphalt Tile—18c to 28c per sq. ft. installed.

Wall Tile

Glazed Terra Cotta Wall Units (single faced) laid in place—approximate prices:

2 x 6 x 12	\$1.00 sq. ft.
4 x 6 x 12	1.50 sq. ft.
2 x 8 x 16	1.10 sq. ft.
4 x 8 x 16	1.30 sq. ft.

Venetian Blinds—

40c per square foot and up. Installation extra.

THE BUILDERS' EXCHANGE OF SAN FRANCISCO STANDARD WAGE SCALE

For mechanics employed on construction work in the Bay Region. Effective September 1, 1937

CRAFT	Journeyman Mechanics
Asbestos Workers	\$ 8.00
Bricklayers (6h-5d)	10.00
Bricklayers' Hodcarriers (6h-5d)	6.75
Cabinet Workers (Outside) (5d)	8.00
Caisson Workers (Open)	6.40
Carpenters (8h-5d)	10.00
Cement Finishers (8h-5d)	10.00
Cork Insulation Workers (8h-5d)	10.00
Electric Workers (8h-5d)	11.00
Electrical Fixture Hangers	8.00
Elevator Constructors	10.40
Engineers, Portable & Hoisting	9.00
Glass Workers (8h-5d)	9.68
Hardwood Floormen	9.00
Housemiths, Architectural Iron (Shop) (8h-5d)	9.00
Housemiths, Architectural Iron (Outside) (8h-5d)	10.00
Housemiths, Reinforced Concrete or Rodmen (8h-5d)	10.00
Iron Workers (Bridge and Structural) Including Engineers (8h-5d)	12.00

CRAFT	Journeyman Mechanics
Laborers, Building (8h-5d)	\$ 6.00
Laborers, Common (8h-5d)	6.00
Lathers, Channel Iron (6h-5d)	9.00
Lathers, All Others	9.00
Marble Setters (8h-5d)	10.50
Marble Setters' Helpers (8h-5d)	5.50
Millwrights	9.00
Model Makers (\$1.50 per hr-6h)	9.00
Modelers (\$2 per hr-6h)	12.00
Model Casters	7.20
Mosaic and Terrazzo Workers (Outside)	9.00
Painters (7h-5d)	8.50
Painters, Varnishers and Polishers (Outside)	9.00
Pile Drivers and Wharf Builders	9.00
Pile Drivers' Engineers	10.00
Plasterers (6h-5d)	10.00
Plasterers' Hodcarriers (6h-5d)	11.00
Plumbers (8h-5d)	7.50
Roofers, Composition (8h-5d)	9.00
Roofers, All Others (8h-5d)	8.00
Sheet Metal Workers (8h-5d)	10.00
Sprinkler Fitters	10.00

CRAFT	Journeyman Mechanics
Steam Fitters (8h-5d)	\$11.00
Stair Builders (8h-5d)	9.00
Stone Cutters, Soft and Granite (8h-5d)	8.00
Stone Setters, Soft and Granite	12.00
Stone Derricksmen	10.00
Tile Setters (8h-5d)	9.00
Tile Setters' Helpers (8h-5d)	6.50
Tile, Cork and Rubber (8h-5d)	9.00
Welders, Structural Steel Frame on Buildings	11.00
Welders, All Others on Buildings	9.00
Dump Truck Drivers, 2 yards or less	6.00
Dump Truck Drivers, 3 yards	6.50
Dump Truck Drivers, 4 yards	7.00
Dump Truck Drivers, 5 yards	7.00
Dump Truck Drivers, yards	7.50
Truck Drivers of Concrete Mixer Trucks:	
2 yards or less	6.50
3 yards	7.00
4 yards	7.50
5 yards	7.50
6 yards	8.00

GENERAL WORKING CONDITIONS

- Eight hours shall constitute a day's work for all crafts except as otherwise noted.
- Plasterers' Hodcarriers, Bricklayers' Hodcarriers, Roofers' Laborers, and Engineers' Portable and Hoisting, shall start 15 minutes before other workmen, both at morning and at noon.
- Five days, consisting of not more than eight hours a day, on Monday to Friday inclusive, shall constitute a week's work.
- Transportation costs in excess of twenty-five cents each way shall be paid by the contractor.
- Overtime shall be paid as follows: For the first four hours after the first eight hours, time and one-half. All time thereafter shall be paid

- double time, Saturdays (except Laborers), Sundays and holidays, from 12 midnight of the preceding day, shall be paid double time.
- On Saturday, Laborers shall be paid straight time for an eight-hour day.
- Where two shifts are worked in any twenty-four hours, shift time shall be straight time. Where three shifts are worked, eight-hour's pay shall be paid for seven hours on the second and third shifts, allowing one-half hour for lunch.
- All work, except as noted in paragraph 9, shall be performed between the hours of 8 a.m. and 5 p.m.
- In emergencies, or where premises cannot be vacated until the close of business, men then

- reporting for work shall work at straight time. Any work performed on such jobs after midnight shall be paid time and one-half up to four hours of overtime and double time thereafter, provided that if a new crew is employed on Saturdays, Sundays or holidays which has not worked during the five preceding days, such crew shall be paid time and one-half.
- Recognized holidays to be: New Year's Day, Decoration Day, Fourth of July, Labor Day, Admission Day, Thanksgiving Day, Christmas Day.
- Men ordered to report for work, for whom no employment is provided, shall be entitled to two hours' pay.

ARCHITECTS' BULLETIN

Issued For

THE STATE ASSOCIATION OF CALIFORNIA ARCHITECTS

Northern Section

STATE ASSOCIATION MEMBER
OF THE
AMERICAN INSTITUTE OF ARCHITECTS
Editor

Harris C. Allen

Address all communications for publication
in the Bulletin to the Editor (Harris C.
Allen) 557 Market Street, Room 218 San
Francisco, California.

Board of Control

Harris C. Allen Otto G. Hintermann
Harry Michelsen Wayne S. Hertzka

State Association Officers

President Sylvanus B. Marston Pasadena
Vice-President Gwynn Officer, Berkeley
Secretary Wayne S. Hertzka, San Francisco
Treasurer Robert H. Orr, Los Angeles

Regional Director, A. I. A.

Albert J. Evers, San Francisco
Deputy Regional Director, Southern
California

Gordon B. Kaufmann, Los Angeles

Executive Board—Northern Section

Officers

President Gwynn Officer, Berkeley
Vice-Pres. Ernest E. Weihe, San Francisco
Secretary Wayne S. Hertzka, San Francisco
Treasurer Otto G. Hintermann, San Francisco

Directors

Harry J. Devine R. H. Reimers
Wm. J. Merchant Harold Weeks

Executive Board—Southern Section

Officers

President Sylvanus B. Marston
Vice-President Louis N. Crawford
Secretary Winsor Soule
Treasurer Robert H. Orr

Directors

Merrill W. Baird Abe Edelman
Harold C. Chambers George D. Riddle

Advisors—Northern Section

Harris C. Allen San Francisco
J. K. Ballantine, Jr. (Secretary)
Sam. Lightner-Hyman
Wm. G. Merchant
Jas. F. McGuiness
Dodge A. Riedy
Harold H. Weeks
Ernest E. Weihe
Albert R. Williams
Fred. H. Reimers (President)
C. A. Caulkins North Bay District
Peter Sala Lower San Joaquin
District
J. U. Cloudsley (Secretary)
Edw. W. Kress Santa Clara Valley
Mario Corbett San Mateo
Alden Cambell Sacramento
Ernest J. Kump Upper San Joaquin
Dole F. Thomsen Palo Alto
Norman W. Sexton Marin
Geo. P. Simonds East Bay
Chester Treichel East Bay
Gwynn Officer Berkeley
F. T. Georgeson Redwood Empire
Casebolt Dakin Upper Sacramento
Ralph Taylor Lassen District

Architects Dine on Treasure Island

A JOINT meeting of the Association, Northern Section, and the Northern California Chapter of the American Institute of Architects was held February 24th, in the shape of a dinner in the Administration Building on the Fair Grounds—Golden Gate International Exposition, to you.

About a hundred attended, with some ladies and guests. A good chance was provided for a general early view of Treasure Island and the miracles performed by architects, gardeners and lighting experts. Those attending have doubtless carried word back to their respective communities of the Fair's beauty and coherence—and, being architects, have probably added some critical comments about this and that.

It may be said that all the suggested improvements would have cost a lot of money. One of the greatest miracles was, that so much was actually done for such a comparatively small expenditure. Many features, originally planned, had to be eliminated or drastically cut down. But with the work completed, following all visions and revisions, there is now no doubt that the Fair will be a popular success, and will repay architects especially, for many visits and revisits, even if its architecture fails of inspiration for current design.

At the meeting, all other business was subordinated to considering activities and recommendations of the Legislative Committee. Since this committee (headed by Harry Devine of Sacramento) takes the place of any and all "lobbyists," it not only gives freely of its own time and energy, but properly demands the wholehearted backing and active support of all Association members.

LEGISLATIVE REPORT

The Executive Board has employed "checkers" to go through 4,000 Bills introduced in this Legislature, and report all items bearing on the building industry. A similar survey, made by the contractors, has been accessible. This is not final, for all Bills may be amended when the Legislature reconvenes.

There are several "mystery" Bills on which our committee is keeping an eye, but the only one openly and clearly adverse to the interests of the profession and also obviously contrary to public welfare is the "Fee Bill" referred to in the last Bulletin (Nos. 752 and 753), which reduces architects' fees on all public buildings to such an almost vanishing point that neither adequate service nor reasonable compensation can be obtained.

All members were urged (and agreed) to communicate promptly with their district assemblymen and senators with all legitimate efforts to protest against the enormity of such low fees (which sounds like a paradox but is, figuratively an understatement), and also to urge confirmation of the newly codified Architectural Practice Act, Senate Bill No. 186.

DINNER ATTENDANTS

Among those at the Treasure Island meeting were: Mr. Frederick R. Stott of the Federal Housing Administration, Mr. and Mrs. L. Meek, Mr. and Mrs. H. Spaulding, Miss J. M. Cathcart, Charles F. Masten, Harry Michelsen, Chester Miller, Wm. B. Merchant, Jas. H. Mitchell, Wm. McCormick, Jerry Molino, Irving Morrow, Keith O. Narbett, Archie Newsom, Harry Nye, Wm. H. Knowles, Warren C. Perry, L. E. Peyser, Martin Rist, Dodge Riedy, M. D. Reynolds, W. H. Rowe, C. J. Ryland, C. J. Sly, J. L. Stewart, W. A. Stevens, Si Sato, O. R. Thayer, C. Trudell, Harold Weeks, Ernest Weihe, Al. R. Williams, A. C. Williams, Mort. A. Williams, Harris C. Allen, F. E. Amandes, Dick Audsley, J. K. Ballantine, E. G. Bangs, Elizabeth Boyter, A. W. Burgen, G. E. Ralph, W. W. Campbell, E. W. Cannon, C. J. Caulkins, Loy Chamberlain, C. F. Dean, J. H. Devitt, Harry Devine, J. J. Donovan, T. M. Edwards, A. J. Evers, E. R. French, Bud Fraser, Edw. Frick, W. B. Glynn, Wayne S. Hertzka, L. Hansberry, E. Hildebrandt, Otto G. Hintermann, David Horn, Mr. Hussey, R. R. Irvine, Kepbler B. Johnson, Conrad Kett, Mr. Kilmartin, H. K. Lovell, W. W. Wurster, Jack Wagstaff, Ralph Wyckoff, W. R. Yelland, L. Mastropasqua, W. Mooser, Jr., Edward Kress, E. N. Curtis, J. D. Young, Chas. E. Butner, N. K. Blanchard, E. B. Page and W. A. Rich.

SOUTHERN CALIFORNIA CHAPTER

Interest centered in the honor awards program which featured the February 14th meeting of Southern California Chapter, A.I.A., at the Los Angeles Biltmore. Details of these awards are published elsewhere in this issue. Approximately 250 Chapter members and their guests attended the meeting, the guests including owners of the buildings given honor awards and members of the City Planning Commission, City Council and Board of Supervisors.

Herbert J. Powell spoke on behalf of the architects who received awards and Roger Jessup, chairman of the Board of Supervisors of Los Angeles County, spoke on behalf of the community. Photographs of the buildings selected were exhibited in the music room of the Biltmore, the exhibit having been prepared by Charles O. Matcham, Walter Reichardt and Douglas Honnold.

Reports were made by William H. Harrison, chairman of the honor awards committee, and by Paul Robinson Hunter, chairman of the committee in charge of the preparation of the Chapter book, "Residence Architecture of Southern California," now being printed.

Nominations of delegates to the Institute convention to be held in Washington, D.C., in September, were made as follows: Eugene Weston, Jr., Ben H. O'Connor, George Adams, Robert H. Ainsworth, John C. Austin, D. C. Allison, Edgar Bissantz, Roland E. Coate,

Walter Davis, Pierpont Davis, A. M. Edelman, Ralph C. Flewelling, William Harrison, Earl T. Heitschmidt, Myron Hunt, C. Raimond Johnson, Reginald D. Johnson, Gordon B. Kaufmann, Donald Kirby, Samuel E. Lunden, Richard Neutra, Herbert Powell, Carleton M. Winslow and David J. Witmer.

OREGON CHAPTER ANNUAL MEETING

Seventy-one members and guests attended the Twenty-Seventh Annual Meeting of Oregon Chapter, A.I.A., at Congress Hotel, Portland, January 17.

The walls of the dining room being adorned by a large collection of travel sketches and photographs by Arthur Riehl, members spent the first hour viewing this exhibit.

Retiring President Howell called the business meeting to order at 6:00 p.m.

Mr. Jacobberger made an extensive report on the letter received from the General Building Contractors Association relative to suggested changes in bidding practices. This report was accepted with the following modifications: "That although architects generally favor one general contractor for a building operation, architects reserve the right to get sub-bids on any crafts for better supervision."

It was moved and carried that the secretary be instructed to make further inquiries relative to the Cleveland Chapter's strange actions as reported in the last "Octagon."

A unanimous ballot was cast for the new officers as designated by the nominating committee.

Messrs. Howell and Stanton then made respective addresses to the Chapter.

Dinner was served at 7:30 with Fred Aandahl as toastmaster.

As the conviviality spread, inspiring but, fortunately, brief addresses were made by President Miller of the O.B.C., Commissioner Bean, Morris Whitehouse, Victor Jones and President Stanton. Serious addresses by Jacobberger, relative to the architectural clinic, and by Doty, on "What the Future Holds," precipitated much comment and praise.

The secretary was instructed by unanimous rising vote of the entire assembly to address a letter to the Washington State Chapter and Mrs. Gould, expressing sorrow at the passing of Carl F. Gould, F.A.I.A., of Seattle.

The guest speaker of the evening, Harry Freeman of the City Planning Commission, then gave a very instructive talk on the broad general aspects of the development of the plan of the City of Portland. The lecture was accompanied by descriptive maps and charts.

Because of the unusually large attendance of Chapter members and associates, this meeting was considered a huge success.

(Turn to Page 68)

MODERNIZED PRODUCTS

Brief Notes on New Materials and Equipment in the Building Industry.

180. CELOTEX NEWS

"The Celotex News," reflects the latest advances in the field of building insulation and protection. Published by the Celotex Corporation, it makes very worthwhile reading. The February issue has just been received. Send for a copy by using the coupon below.

181. WESTERN PINE

A brand new booklet by the Western Pine Association, tells of the uses of western pine for home building. Practical suggestions are offered and the booklet is illustrated. It covers the use of Idaho white pine, Ponderosa pine and sugar pine.

182. COPPER GROUND RODS

The Anaconda Wire and Cable Company has issued a booklet describing a new product, "Solid Copper Ground Rods." This is the latest piece of equipment for the correct and proper grounding of high tension cables and is adapted for use where deep grinding is essential. Send for a copy.

183. STEEL FACTS

The February issue of "Steel Facts," a pamphlet put out by the American Iron and Steel Institute, prints some surprising facts pertaining to the steel industry. An interesting feature is a map showing the location of rolling mills in 1889 and in 1939. Use the coupon for your copy.

184. LIGHT WEIGHT CONCRETE

For the Celotex Corporation the Carnegie-Illinois Steel Company will manufacture "Pottscoc" light weight concrete units. This new product is illustrated in a booklet put out by Celotex under the name of "Pottscoc for better buildings."

185. VENETIAN BLINDS

The Rolscreen Company has issued an illustrated booklet about screens and "Neo-Classic," a new Venetian blind. Send for a copy by using the coupon.

186. ELECTRIC POWER

Another of the excellent bulletins put out by the Copper and Brass Research Association has been received. This particular bulletin is most interesting and deals with power producing stations and electric installations. Send for a copy.

187. NICKEL

The International Nickel Company has issued a technical bulletin on the "Engineering Properties of Nickel." This booklet contains interesting details of a technical nature.

188. ASPHALT FLOORS

A new booklet from the Johns-Manville Company in which is featured a new "Decorative Asphalt Tile Flooring." Information for architects and builders is included; also information for consumer or home owner. The coupon will bring you a copy.

189. PAINT MATERIALS

The Dutch Boy Quarterly, Vol. 16 No. 4, has just been released and contains valuable information on paint materials, lead and related products. It is issued by the National Lead Company.

190. LIGHTING

Curtis Lighting Co. has a brochure featuring "Economy Line" in modern lighting fixtures. This one in particular deals with the "Rival," a new indirect pendant. Send for a copy by using the coupon.

191. ELECTRIC FANS

A catalog of electric fans has been put out by the Emerson Electric Company. Well illustrated and with full specifications, it should prove of interest.

192. AIR COOLING

The Carrier Corporation has a new catalog on heating, refrigerating and ventilating units. Very complete and with all details explained and specifications given. The coupon will bring you a copy.

193. FLOOR PROBLEMS

A broadside issued by The Flexrock Company on their new "smooth, tough" floors has several interesting features and contains a questionnaire on the back cover on which you can check your floor problems which will be answered by a staff expert.

194. ENGINE ROOM DATA

A technical booklet on boiler water level control has been issued by the McDonnell and Miller Company. The booklet is well illustrated and gives details of boiler water feeders, low water cut-offs and other essentials of engine room interest. Send for your copy. Clip the coupon.

FREE FOR THE ASKING

Check items on coupon, paste on letter head or postal card, and mail to Architect and Engineer.

Architect and Engineer
68 Post Street
San Francisco, Calif.

Please send me literature on the following items as checked below. This request places me under no obligation.

- | | |
|------------------------------|------------------------------|
| <input type="checkbox"/> 180 | <input type="checkbox"/> 187 |
| <input type="checkbox"/> 181 | <input type="checkbox"/> 188 |
| <input type="checkbox"/> 182 | <input type="checkbox"/> 189 |
| <input type="checkbox"/> 183 | <input type="checkbox"/> 190 |
| <input type="checkbox"/> 184 | <input type="checkbox"/> 191 |
| <input type="checkbox"/> 185 | <input type="checkbox"/> 192 |
| <input type="checkbox"/> 186 | <input type="checkbox"/> 193 |
| <input type="checkbox"/> 194 | |

My Name

Name of Company

Street

City State

EMERGENCY ACT RELEASES \$50,000,000 FUND FOR CALIFORNIA HOUSING

TO remove any obstacles for the immediate construction of fifty million dollars worth of new housing in California, the State Legislature has passed the following emergency measure, effective at once:

An act to amend sections 30 and 43 of the State Housing Act, relating to building construction, and specifying room dimensions and stairway widths, to take effect immediately.

The people of the State of California do enact as follows:

Section 1. Section 30 of the act cited in the title hereof is hereby amended to read as follows:

Sec. 30. In every apartment in every apartment house hereafter erected there shall be at least one room that contains not less than one hundred twenty square feet of superficial floor area, and every other room shall contain not less than ninety square feet of superficial floor area.

In every hotel hereafter erected each guest room shall contain not less than ninety square feet of superficial floor area; provided, however, that guest rooms in hotels may contain a superficial floor area of less than ninety square feet and not less than seventy square feet; provided, that the required aggregate window area in each such room be not less than sixteen square feet; and provided, further, that any such guest room which contains a superficial floor area of less than ninety square feet shall not be occupied or designed for occupancy by more than one person for sleeping purposes. The minimum width of every room in an apartment house or hotel hereafter erected shall be not less than seven feet at any point within that portion of the room counted for computing the minimum allowable area of such room. In every dwelling hereafter erected each room therein designed, built or intended for use of sleeping purposes, shall contain not less than eighty square feet of superficial floor area and every such room shall be designed so that the minimum width shall not be less than seven feet at any point within that portion of the room counted for computing the minimum area of eighty square feet.

Every kitchen in an apartment house or dwelling hereafter erected shall contain not less than fifty square feet of superficial floor area.

In every apartment house not more than two stories in height or dwelling hereafter erected, every room shall have a ceiling height of not less than eight feet measured from the finished floor to the finished ceiling. In every apartment house more than two stories in height or hotel hereafter erected every room shall have a ceiling height of not less than nine feet measured from the finished floor to the finished ceiling; provided, however, that ceiling heights in rooms of apartment houses more than two stories in height or hotels may be less than nine feet but not less than eight feet; provided, that where any such ceiling height is so reduced in any room, required by the provisions of this act in such buildings to have a minimum superficial floor area, the cubic air content of that room shall be computed on the basis of a nine-foot ceiling height measured in a manner conforming to the provisions of this section. In any room in any building hereafter erected, wherein such room sloping ceilings occur, there need only be the prescribed ceiling heights in not less than one-half of the area of the room; provided, however, that no portion of any such room wherein the height measured from the finished floor to the finished ceiling, is less than five feet shall be included in any computation for the minimum area of such room, nor shall any portion of the room inclosure have a clear ceiling height of less than three feet. The foregoing provisions of this section shall not apply to water-closet, bath or slop sink compartments, nor to closets, recesses from rooms and dressing rooms, nor shall the minimum width of rooms apply to kitchens.

Every water-closet compartment in every building hereafter erected, shall be not less than thirty inches in clear width, and every such water-closet compartment, bath or slop sink compartment, closet, or recess from a room shall have a ceiling height of not less than seven feet and six inches, measured from the finished floor to the finished ceiling; provided, that any such compartment or closet where sloping ceilings occur shall have the prescribed ceiling height in not less than one-half of the area of the compartment or closet. In every apartment house designed and built to accommodate three or more families above the first story thereof, and in every hotel hereafter erected, every closet, recess from a room or dressing room, which contains more than twenty-five square feet of superficial floor area, exclusive of the area occupied by built-in dressers, clothes presses and similar features and fixtures which are a substantial part of the building and which are not readily removable, shall conform to all of the provisions of this act for rooms and shall contain not less than the minimum allowable superficial floor area.

No part of any room in any apartment house or hotel shall hereafter be inclosed or subdivided, wholly or in part, by a curtain, portiere, fixed or movable partition, or other contrivance or device, for any purpose contrary to any of the provisions of this act.

Entertainment, amusement, or reception rooms hereafter constructed, altered or converted, in an apartment house or hotel shall conform to the provisions of section 32 of this act.

Dormitories hereafter constructed, altered or converted in any building shall conform to the provisions of section 62 of this act.

Apartment houses and hotels of three or more stories in height hereafter erected, except where in this act otherwise provided, all partitions shall be well plastered partitions.

Sec. 2. Section 43 of said act is hereby amended to read as follows:

Sec. 43. Every fireproof apartment house or hotel hereafter erected shall have not less than one stairway, not less than three feet six inches wide, for each six thousand square feet, or fractional part thereof, of floor area in any one floor above the first floor thereof.

Every fireproof apartment house or hotel hereafter erected shall have not less than one stairway, not less than three feet six inches wide, for each four thousand square feet, or fractional part thereof, of floor area in any one floor above the first floor thereof.

Every wooden apartment house or hotel hereafter erected shall have not less than one stairway, not less than three feet six inches wide, for each three thousand square feet, or fractional part thereof, of floor area in any one floor above the first floor thereof.

In an apartment situated only on the first and second stories of an apartment house, any required stairway terminating at the second story and for the exclusive use of the occupants of the apartment and their invitees, may be not less than three feet in width.

Every apartment house or hotel three or more stories in height hereafter erected, shall have not less than one stairway leading from the outside to every basement or cellar thereof.

Sec. 3. This act is hereby declared to be an urgency measure necessary for the immediate preservation of public peace, health and safety within the meaning of section 1 of Article IV of the Constitution and shall therefore go into immediate effect. A statement of the facts constituting such necessity is as follows:

Unemployment and the existence of unsafe, insanitary and congested dwelling accommodations has produced an alarming economic condition in the State of California. The Federal Gov-

erment as part of a nationwide program, has provided machinery for remedying this situation through the United States Housing Authority. In order to receive the benefits from that organization, however, the Federal Government specifically requires that housing projects meet certain standards which are conducive toward safe housing. The present standards set up under the State Housing Act are at variance with these requirements, thus rendering California ineligible to receive benefits under the Federal act. The immediate adoption of this act will enable many housing projects to be undertaken in this State which otherwise can not be financed at this time. This development and construction will furnish employment to many persons now idle and enable them to become self-supporting and will alleviate the aforesaid housing conditions.

At the present time the sum of fifty million dollars has been allocated for assistance in housing in California; of this sum, the sum of thirty million dollars has been allocated for use in the city and in the county of Los Angeles, fifteen million dollars for use in the City and County of San Francisco, and five million dollars for use in the county of Alameda. But until the State Housing Act is amended as provided in this act, these funds are not available for immediate use.

REGISTRATION OF ENGINEERS

Twenty-three applicants were issued certificates of registration as civil engineers; three applicants were issued licenses as land surveyors, and six civil engineers were authorized to use the title structural engineer by the State Board of Registration for Civil Engineers at its annual meeting January 10.

Applicants in Southern California to whom civil engineering registration was granted are: David M. Anderson and Frederick R. Cline, U. S. Engineer's Office; Harvey O. Banks and Kirby V. Jones, State Division of Water Resources; Earl R. Bennett, engineer; Robert E. Milsap, general contractor; Donald Douglas, engineer, Witmer & Watson, architects; Homer Fallai and W. A. McIntyre, State Highway Department; Howard R. Hineman, James Jennison, State Bridge Department; John G. Hughes, General Petroleum Corporation; Ernest B. Hugg, Board of Fire Underwriters of the Pacific; Paul F. Keim, Los Angeles County Flood Control; Frank L. Smith, Southern California Gas Company, and Richard M. Merriman, all of Los Angeles; Aubrey Boles, building inspector, El Centro; Boyd G. Eubank, U. S. Soil Conservation, Whittier; Clifton T. Greene, State Division of Highways, San Diego; Arthur E. Howland, engineer, Manley Sahlberg, architect, Santa Paula; C. V. Kane, State Division of Highways, San Bernardino; George M. Underwood, National Tank and Manufacturing Co.; Charles P. Hoover and J. M. Montgomery of Columbus, Ohio, consultants for Metropolitan Water District of Southern California.

Land surveyors licenses were issued to: G. W. Elder, San Fernando; Evatt A. McClenaghan, Encinitas; and N. Jerome Bowen, Los Angeles.

Authority to use the title "structural engineer" was granted Sidney F. Bamberger, Joseph Sheffet, Charles Peterson, Jack N. Sparling and Bruce M. Dack, all of Los Angeles and Charles M. Herd of Pasadena.

JOHNSON

Since 1904

Pioneers in the manufacture of Oil Burners for every need of Home and Industry.

Let us help you solve your problem of heating and ventilating.

•
Worthwhile territories and Johnson franchises available



S. T. JOHNSON CO.

940 Arlington, Oakland, Calif.
401 N. Broad St.
Philadelphia, Pa.



SELECTAIR

• Compact, dependable, this split system air-conditioning unit offers every desired feature for economical heating, air-conditioning and ventilating the home. With year-round domestic hot water. Oil-fired by the Johnson Pressure Type "Bankheat" Burner.

Pressure
Treated Lumber?

Specify

BAXCO CZC

"Chromated Zinc
Chloride"

Protects against decay
and termite attack

•
Available for prompt shipment
throughout California

•
J. H. BAXTER & CO.

601 W. 5th Street
LOS ANGELES
Phone Michigan 6294

333 Montgomery Street
SAN FRANCISCO
Phone DOUGLAS 3883

"The Nation's Schoolhouse Window"

**DALMO Simplex
Fixtures**

Efficient Plumbing

**KRAMER Flush
Valves**

Supreme Light Control

**ALUMILITE
Venetian Blinds**

MacDONALD
HARDWARE MANUFACTURING CO.



YUkon 0123

963 Harrison St.

San Francisco

STANLEY

**THE SYMBOL OF LEADERSHIP
IN DOOR HARDWARE FOR 90 YEARS**

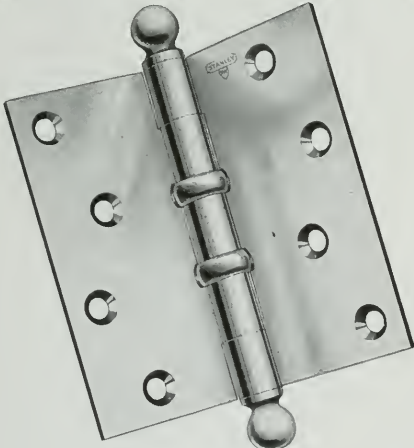

THE STANLEY WORKS
New Britain, Conn.

SAN FRANCISCO 376 Monadnock Bldg. LOS ANGELES 407 American Bank Bldg. SEATTLE 568 First Avenue, South

STANLEY

TRADE MARK

HARDWARE FOR CAREFREE DOORS

OREGON CHAPTER ANNUAL MEETING

(Concluded from Page 64)

1939 Committees

The executive committee has selected the following committees for 1939 activities:

Membership: Jacobberger, chairman; Barnes, Dukehart, A. Lawrence, Morin, Sundeleaf, Wright.

Practice of Architecture: Crowell, chairman; Aandahl, Allyn, Heiler, Hilgers, Holford, Foulkes.

Relations With the Construction Industry: Jones, chairman; Angell, Heims, Logan, Roehr, B. Smith, Tucker, Whitney.

Public Relations: Legge, chairman; Brookman, Hay-slip, Howell, Perrin, Wallman.

Education and Registration: Stanton, chairman; Hemenway, Johnson, Folger, E. F. Lawrence, Wallwork, Willcox.

Public Information: Fritsch, chairman; Bear, Doty, Hartford, I. G. Smith, Wardner.

Allied Arts and Exhibitions: Schneider, chairman; Belluschi, Butcher, Church, Dougan, Harrington, Wolff.

Civic Design: Johnston, chairman; Aandahl, De-Young, Herzog, Kennedy, Marsh, Parker, Whitehouse.

Special Entertainment Committee: Wick, chairman; Cash, Hinson, Kotchik, Turner, Zeller.

"Highlands" Committee: Johnston, Belluschi, Foulkes, Legge.

WASHINGTON STATE CHAPTER

Forty architects attended the annual meeting of Washington State Chapter, A. I. A., January 28 in Seattle.

At the annual banquet, ten new members were initiated. They were Norman Fox, Elizabeth Ayer, Fred Ahlson, Ralf Decker, John Rogers, Perry Johanson, Don Bickford, John Bringlee, Paul Carlson and Ken Ripley. Among the guests were William Frederick Gardiner, Vancouver, B. C., president of the Architectural Institute of British Columbia; Glen Stanton, president of the Oregon Chapter, and Roi Morin, secretary of the Oregon Chapter.

New officers are Floyd A. Naramore, Seattle, president; William J. Bain, Seattle, first vice-president; Nelson J. Morrison, Tacoma, second vice-president; Harold C. Whitehouse, Spokane, third vice-president; Victor Jones, Seattle, secretary; Clyde Grainger, Seattle, treasurer. New members of the executive board are Mr. Bain, B. Marcus Priteca, the outgoing president, and J. Lister Holmes.

The treasurer's report for 1938 showed the Chapter to be in a healthy condition with a permanent fund amounting to \$2,118.24. This, with the current funds on deposit and anticipated revenue from dues for the coming year, gives Chapter resources of \$3,174.86. This report was accepted with appreciation of the valuable services of the treasurer, Clyde Grainger.

Twenty-five new members were taken into the Chapter last year.



Specify
CONDITIONED AIR HEAT
 with the **DELCO CONDITIONAIR**

Product of General Motors

• The Delco Conditionair automatically heats, humidifies, filters, circulates healthful air throughout the home. Many exclusive features that contribute to greater economy and durability. Models for oil or gas. Get all the facts.

ALADDIN HEATING CORPORATION

Delco-Frigidaire Dealer

2222 SAN PABLO AVENUE • OAKLAND

A good investment—

is a well designed, well built,
 structure, properly located.

Lindgren & Swinerton, Inc.

have been building substantial
 buildings for over a half of a cen-
 tury, are still building them and
 will continue building them for
 another half of a century.

Lindgren & Swinerton, Inc.

Standard Oil Building
 San Francisco

619 H Street
 Sacramento

605 W. Olympic Boulevard
 Los Angeles

1723 Webster Street
 Oakland

“Goods of the Woods”

**Dependable
 Building
 Materials**

Lumber and Millwork
 for
All Types of Construction

★

Wolmanized or Creosoted
 Lumber and Timbers
 is your protection against
 Termites and Decay

★

E. K. WOOD LUMBER CO.

San Francisco

Los Angeles

Oakland

The Sensation of the Roofing Industry!



Find out about it!

THE PARAFFINE COMPANIES INC.
 475 Brannan St., San Francisco

Please send information about the new
 Thermoslab.

Name _____

Address _____

City _____

State _____

A & E

POMONA TILES

FOR

Bathrooms and Kitchens
in over 60 colors

Warehouses and Display Rooms

135 Tenth St. San Francisco

629-33 North La Brea Ave. Los Angeles

6106 Roosevelt Way Seattle

POMONA TILE MFG. CO.
PLANT — POMONA, CALIF.



Write for "The Charm of a Well Lighted Home" to help you plan attractive healthful lighting.

Traditional and contemporary designs of Lightolier fixtures are on display in our showrooms. Whether you are working on a new or modernized home you'll find the very designs you want at Incandescent.

INCANDESCENT SUPPLY CO.

SAN FRANCISCO : OAKLAND : FRESNO : LOS ANGELES

STRUCTURAL STEEL

For Class A Buildings,
Bridges, etc.

JUDSON PACIFIC CO.

609 MISSION STREET
SAN FRANCISCO

Plants: San Francisco - Oakland

A Permanent Exposition
of the newest ideas
in home planning
and equipment.



THE BUILDING MATERIAL EXHIBIT

Architects Bldg. • Fifth & Figueroa • Los Angeles • MU-6306

BOOK REVIEWS

BAUHAUS 1919-1928, edited by Herbert Bayer, Ise Gropius, Walter Gropius (Chairman of the Department of Architecture, Harvard University.) 550 illustrations; 224 pages; \$3.75. The Museum of Modern Art, 14 West 49th Street, New York City, N. Y.

A fascinating book for the architect who is interested in the modern philosophy of design. Bauhaus is an answer to the question, "How can an artist be trained to take his place in this, the machine age." The Bauhaus idea began as a school in Germany—its teachers were Walter Gropius, its founder and first director, Kandinsky, Klee, Schlemmer, Albers, Bayer, Breuer and others who taught architecture, housing, painting, sculpture, photography, cinema, theater, industrial design, pottery, metal work, etc. Bauhaus courageously accepts the machine as an instrument worthy of the artist: because it faced the problem of good design for mass production and because it bridged the gap between the artist and the industrial system.

It is suggested that this group, knowing in their own minds the solution of this world's architectural troubles, band together in the publication of a book of their executed designs, giving plans, sections, and photographs taken from a normal point of view. The American architect will then judge for himself.

OUR PROMISED LAND: By Richard Neuberger; The Macmillan Company, New York City, N. Y. Price: \$3.00.

A book that follows the "last frontiers" in this country. That region where the vast projects in reclamation have been going on. Boulder Dam, the Grand Coulee, and others. In this volume the author gives us a vital, living picture of outstanding political figures in the West. The states of California, Washington, Oregon, Idaho, Montana and Wyoming form this new Cannan, and are the last frontier in the battle against the elements.

ENGINEERS' MANUAL: By Ralph G. Hudson, S.B., Massachusetts Institute of Technology; John Wiley & Sons, 440 Fourth Avenue, New York City, N. Y. Price: \$2.75.

Mr. Hudson has given us a new edition (the second) of his very splendid engineer's handbook. The draftsman, architect and engineer will find in this little flexible bound handbook a manual that can be taken into the field and on the job, replete with the information he wants at the moment he needs it. Pocket size.

HOW TO ESTIMATE FOR THE BUILDING TRADES: By Thompson, Dalzell and McKinney; The American Technical Society, Drexel Avenue, at 58th Street, Chicago, Ill. Price: \$4.75.

Complete and practical, it covers the estimating of materials and labor for every phase of building trades. Residences and moderate sized buildings are given full

consideration. The book covers such details as excavations, masonry, lath and plaster, painting, tiling, etc. There is included a set of blue prints, eight in number, drawn to standard scale. Schools, vocational and trade, will find this volume a valuable edition to their reference libraries.

A HISTORY OF AMERICAN GRAPHIC HUMOR—1865-1938: By William Murrell, The Macmillan Company, New York City, N. Y. Price: \$6.50.

A most interesting book, of value to the draftsman as well as the architect; possibly not so much from an architectural standpoint, but surely from a viewpoint of excellent drawing and delineation. Then there is the interest from historical and political angles because of the changing picture almost overnight. This is a most worth while book and the whole format and general set-up makes for an edition of value to the profession.

DESIGN OF INDUSTRIAL EXHAUST SYSTEMS: By John L. Alden; The Industrial Press, 140 Lafayette Street, New York City, N. Y. Price: \$3.00.

This book has a very definite purpose. It seeks to tell the engineer how to properly design and build or to buy an exhaust system that will do the things he desires to have it do for any specific job. The book covers flow of fluids, air flow through hoods, pipe resistance, and the other general and particular details that comprise an adequate exhaust system. The engineer will find this a mine of intensively valuable information and it would not be out of place on the working shelf of the modern American architect.

AWARDS TO ENGINEERS

With nearly 2,000 of its 15,780 members in attendance, the American Society of Civil Engineers held its 86th annual convention at New York January 18 to 21.

A feature of the opening session was the presentation of the Hoover Medal in Engineering to John Frank Stevens, past president and honorary member of the Society, by the American Society of Mechanical Engineers.

Honorary membership was conferred by the Society on C. Frank Allen, of Boston, Professor Emeritus of Massachusetts Institute of Technology; Anson Marston, past-president of the Society and Dean Emeritus of Engineering of Iowa State College, Ames, Iowa; Arthur S. Tuttle, past-president of the Society, who has spent most of his life serving the City of New York in an engineering capacity; Frank E. Weymouth, general manager and chief engineer of the Metropolitan Water District of Southern California, who has just completed the Los Angeles Aqueduct; and Edward E. Wall, Director of Public Utilities for St. Louis, Missouri.

Hunter Rouse, assistant professor of fluid mechanics at California Institute of Technology, was presented with the Norman Medal, the premier medal award of the Society for a paper on "Modern Conceptions of the Mechanics of Fluid Turbulence."

INCLUDE TREES IN YOUR PLANS

DAVEY, ORIGINATOR OF TREE SURGERY, OFFERS FREE INSPECTION AND ESTIMATE.



SAN FRANCISCO Fresno LOS ANGELES
Russ Bldg. Mattei Bldg. Story Bldg.
SUiter 3377 Tucker 1929
Local phones in: Pasadena, Palo Alto,
Oakland, San Rafael, San Mateo

SKILL - KNOWLEDGE - RESPONSIBILITY



PRODUCTS

VAN ARSDALE-HARRIS Co.
ENGINEERS & CONTRACTORS

ACOUSTICAL TREATMENT - INSULATION
SOUND CONTROL

FIFTH & BRANNAN STS. SAN FRANCISCO, CALIF.
TELEPHONE GARfield 3600

DIVISION

VAN ARSDALE-HARRIS LUMBER CO., INC.

USE BASALITE

Light-weight, pre-fabricated Concrete building products for floors, walls, and roofs in your next building.

BASALT ROCK COMPANY, INC.

Napa, California

NOISE CONTROL— ON TREASURE ISLAND

STATE AUDITORIUM AND RADIO STUDIOS
BELL TELEPHONE SYSTEM EXHIBIT
SAN FRANCISCO RECREATION EXHIBIT
FEDERAL BUILDING THEATER

Furnished by—

WESTERN ASBESTOS CO.

Building Materials Mechanical Specialties
SACRAMENTO OAKLAND
SAN FRANCISCO

Is an
AGENCY ACCOUNT
expensive?



By saving valuable time and avoiding losses due to mistakes and delays, our Agency Service for handling securities often is an actual economy rather than an expense. But in any event the cost is moderate. Send for our descriptive booklet, *An Introduction to Agency Service*.

Just ask for Booklet M-2

**CROCKER FIRST
NATIONAL BANK**
OF SAN FRANCISCO
California's Oldest National Bank



*No longer a problem
for the Architect*

**TRANSIT
MIX CONCRETE**
AND MORTAR

makes delivery of material to the job swift and inexpensive . . . minimizing the architect's supervision costs and assuring his client a dependable mix.

Speed . . . Reliability . . . Economy
Let us co-operate with you

**Golden Gate-Atlas
Materials Co.**

16th and Harrison Streets
San Francisco
UNderhill 3650

**NATIONAL EXHIBITION OF
BUILDINGS**

En route to the Pacific Coast is a collection of pictures and drawings comprising "The National Exhibition of Representative Buildings of the Post-War Period." Its circulation is managed by the American Federation of Arts. The assembling of this exhibition is the work of the Committee on Education of the American Institute of Architects. This committee has as its chairman Mr. C. C. Zantzing of Philadelphia, and Dean William Emerson of M. I. T. as vice-chairman.

The exhibit is of particular interest to architects because of the selection made from an enormous field. Many of the examples shown are well known. Below are listed, with the architects' names, most of the exhibits.

Federal Buildings in Washington, D. C.

Federal Trade Commission (Bennett, Parsons & Frost); Departments of Labor, Interior and Commerce (Arthur Brown, Jr.); Federal Reserve Board (Paul Cret); Post Office Department (Delano & Aldrich); Archives Building (Office of John Russell Pope); Interior Department (Waddy Wood); Commerce (York & Sawyer); Justice (Zantzing & Borie); Internal Revenue and Bureau of Engraving (Supervising Architect's Office); U. S. Post Offices and Court Houses designed by architects in the Procurement Division, Supervising Architect's Office. There are aerial views showing orientation of buildings.

State and Other Government Buildings

Ramsey County Court House and St. Paul City Hall (Holabird & Root); North Dakota State Capitol (De Remer & Kurke with Holabird & Root, Assoc.); Hartford County, Conn. Court House (Paul Cret with Smith & Basset); Forest Products Laboratory, Madison (Holabird & Root).

Municipal Auditoriums

Kansas City (Alonzo Gentry, Voskamp & Neville, Hoit, Price & Barnes); Oklahoma City (J. O. Parr); San Antonio, Texas (Ayres & Ayres).

Office and Business Buildings

Rockefeller Center, New York; American Bank and Trust Company, Philadelphia (Davis, Dunlap & Barney); Field Building, Chicago (Graham, Anderson, Probst & White); Daily News

Copper Halftones
in this issue

Made by

**Continental Engraving
& Color Plate
Co.**

156 Second Street
San Francisco

**JOSEPH MUSTO
SONS-KEENAN
COMPANY**

MARBLE
and
ONYX

535 NORTH POINT STREET
SAN FRANCISCO
1801 S. SOTO STREET
LOS ANGELES

SISALKRAFT
REG. U. S. PAT. OFF.

**"More than a
building paper"**

THE SISALKRAFT CO.

205 West Wacker Drive
(Canal Station) Chicago, Ill.
55 New Montgomery Street
San Francisco, Calif.

**Pacific
Manufacturing
Company**

High Class Interior Finish
Quality Millwork

142 Sansome St. 6820 McKinley Ave.
San Francisco Los Angeles
GARfield 7755 THornwall 4196

1315 Seventh Street, Oakland
GLencourt 7850



Specify the
WESIX 49'er

CLIENTS will bless you for installing the Wesix "49'er" **ELECTRIC BATHROOM HEATER**. But try it first in your own home. Certain that you will like its forty-nine inches of **INSTANT RADIANT HEAT** and **QUICK CIRCULATING HEAT**, we are offering this smart new heater at *factory cost to architects*, for personal use limit one heater per architect. List price \$21.50. Please write on your regular letterhead, to: **1018 WESIX BLDG., SAN FRANCISCO**

WESIX
WESIX ELECTRIC HEATER CO.

Building, Chicago (Holabird & Root); Chicago Tribune and New York News (Howells, Hood & Foulhoux); Empire State Building, New York (Shreve, Lamb & Harmon); 450 Sutter St., San Francisco (Miller & Pflueger); Northwestern Bell Telephone Building, Minneapolis (Hewitt & Brown and Rhodes Robertson); Beekman Tower, New York (John Mead Howells); Irving Trust Bldg., New York (Voorhees, Gmelin & Walker); Kress & Company Bldg., New York (Edward F. Sibbert).

Libraries and Memorial Buildings

At Pasadena, Cal.; Baltimore, Md.; Westbury, Long Island (Tilton & Githens); at Los Angeles, Cal. (Goodhue); Folger Shakespeare Library, Washington, D. C. (Paul Cret); Indiana War Memorial, Indianapolis (Walker & Weeks); Joslyn Memorial, Omaha (John and Alan McDonald); Bok Singing Tower, Florida (Milton B. Medary); Art Museum, Seattle (Bebb & Gould); Goodhue's Spanish Renaissance Dome, erected for the 1915 San Diego Exposition, with post-War annexes by Cram & Ferguson.

Churches

Grace Ev. Lutheran Church, River Forest, Illinois (Tallmadge & Watson); Our Lady of Lourdes, Los Angeles (L. G. Scherer); Church of St. Joseph, Seattle (Albertson, Wilson & Richardson); Cathedral of St. John the Divine, New York, Interior (Cram & Ferguson).

Engineering Works with Architect

Golden Gate Bridge, San Francisco (Strauss & Paine, Inc.); Hoover Dam Power House (Gordon B. Kaufmann).

The genesis of the exhibit is found in a request to the A. I. A. more than two years ago from the Royal Institute of British Architects for an exhibition of contemporary American architecture to be shown in the R. I. B. A. Building in London. The Committee on Education started to work on this, but finding a representative show would pass beyond the bounds of an exhibit such as the R. I. B. A. contemplated, the London show was dropped but the Committee continued its labors.

More than one thousand buildings were submitted by officials and directors of the A. I. A., Chapters, unaffiliated practicing architects, and architectural schools. The specific intent

Pitcher

Improved Disappearing Doors Save 20% Space

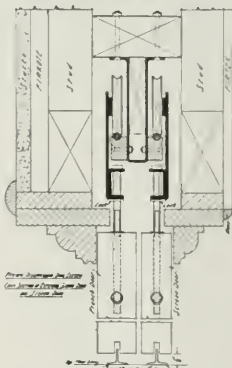

Joins with a 3/4" stud wall . . . steel studs . . . adjustable steel and wood track. Can be used for screen doors in connection with French doors. Send for detail drawing.

E. C. Pitcher Co.

461 Market Street
San Francisco



HERRICK IRON WORKS

STRUCTURAL STEEL REINFORCING STEEL

18TH AND CAMPBELL STS.
OAKLAND, CALIF.
Phone 6Lencourt 1767

FORDERER CORNICHE WORKS

Manufacturers of

- Hollow Metal Products
- Interior Metal Trim
- Elevator Fronts and Cabs
- Metal Plaster Accessories
- Sanitary Metal Base
- Metal Cabinets
- Flat and Roll Metal Screens
- Commercial Refrigerators

269 POTRERO AVE.
San Francisco, Calif.
HEmlock 4100

Donovan Automatic Awning Type Windows

Give 100% natural ventilation and day-lighting control

UNIVERSAL WINDOW COMPANY

Berkeley, California

"AMERICAN MARSH" Redi-Vac Vacuum Heating Pump

Send for Bulletin 441

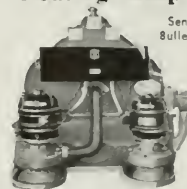

SIMONDS MACHINERY CO.
San Francisco 816 Folsom St. Los Angeles 455 East Fourth St.



SANTA MARIA INN

Santa Maria, California

On the Coast Highway
between

Los Angeles and San Francisco

OVER NIGHT

or

JUST A MEAL

FRANK J. MCCOY, *Owner*

Geo. A. Thompson, *Manager*

El Encanto Hotel

Santa Barbara

On the Riviera, above the
Old Mission

Frank J. McCoy, *Owner*

Fred F. Pimental, *Manager*

was to choose representative buildings, irrespective of school, style, or individual. The exhibit is booked on a two year tour, with showings in all principal cities, schools and universities in this country. Its purpose is educational.

PLUMBING THE SMALL HOME

"The small home offers the largest market for the plumbing and heating contractor today," said Russell G. Creviston, director of advertising and sales promotion, Crane Co., in an address, "The Importance of the Small Home Market," at the 45th annual convention of the Wisconsin Master Plumbers Association.

Mr. Creviston cited the various factors which have combined to increase the volume of construction in the small low cost house field and offered suggestions as to how this type of business may be handled at a profit by the plumbing and heating contractor.

"A change in the traditional attitude of the industry toward the small home is necessary," Mr. Creviston said. "In the past we have considered this market unprofitable.

"Today, the fact that this is our largest market has made it necessary to take the small home out of No Man's Land. We have to get into the battle in the sector that is the most active—the small home field."

Mr. Creviston explained why there is more activity in the field of small house construction than in any other branch. Statistics on the income of various groups of the American people show, he said, that only 50 per cent can afford to build or buy a house costing \$3,000. Only 25 out of every 100 families can afford to build or buy a house costing \$5,000.

"While it is true that there is a housing shortage, this housing deficiency is entirely in the low cost field. There is no shortage of houses costing \$10,000 and more," Mr. Creviston said and then explained that this did not necessarily mean that houses costing \$10,000 or more would not be built.

"Families are smaller today and the trend is toward the compact, efficient type of house, easy to run and economical as to upkeep and taxes."

COMFORT

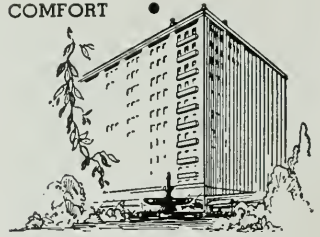

New

HOTEL CLARK

in Downtown

LOS ANGELES

Convenience is another offering of this hotel. Whether on business or pleasure bent, the Hotel Clark makes an ideal "base of operations," as well as a restful "billet" at the end of the day's "campaign." Good Food, naturally. And moderate charges, as well as for room accommodations, give final significance to assuring word — COMFORT

Single from \$2.50

Double from \$3.50

ROOMS
555
BATHS

Fifth and Hill

P. G. B. MORRIS, *Manager*

Independent Iron Works

Structural Steel

Ornamental Iron

Steel Service Stations

Steel Tanks

Standard Steel Mill Buildings

Bridges



821 Pine Street

Oakland

Clinton Construction Co. of California

General
Contractors



923 Folsom Street

San Francisco

SUtter 3440

ANDERSON & RINGROSE

General Contractors

320 Market Street, San Francisco

Phone GARfield 2245

HIGH GRADE MILLWORK
AND INTERIOR FINISH
SASH AND DOORS

LANNOM BROS. MFG. CO.

FIFTH AND MAGNOLIA STREETS
OAKLAND, CALIFORNIA

Telephone: TEmplebar 3663

MULLEN MFG. COMPANY

BANK, STORE AND OFFICE
FIXTURES - CABINET WORK
OF GUARANTEED QUALITY
CHURCH SEATING

Office and Factory:
60-80 RAUSCH ST., Bet. 7th and 8th Sts.
San Francisco
Telephone UNderhill 5815

G. P. W. JENSEN & SON

Building Construction

320 Market Street, San Francisco
Phone: GARfield 2444

DINWIDDIE CONSTRUCTION COMPANY • BUILDERS •

CROCKER BUILDING
SAN FRANCISCO

Carl T. Doell Co.

Plumbing
Heating

Plumbing Contractor
Veterans Memorial Building
Oakland

467 21ST STREET
OAKLAND

Telephone GLencourt 8246

LOW COST SMALL HOUSES

Private enterprise, after months of study and preparation, has opened the door to a new era in low cost housing in announcing the development of individual, detached dwellings available to buyers at a cost of from 50 cents to a dollar a day.

The National Lumber Manufacturers Association and the National Retail Lumber Dealers Association are the co-sponsors of the program which provides two basic house designs with a dozen architectural variations, the houses to cost from \$2000 to \$2500 each.

The two designs include a one-story house, containing living room, two bedrooms, kitchen and bath, and a two-story dwelling with living room, dining room and kitchen on the first floor and two bedrooms and bath on the second floor. A built-in garage is included in the latter plan.

In developing these low-cost homes, the two associations sought and obtained the cooperation of leading manufacturers of building materials and equipment, conferred with housing research foundations, prominent architects, home economists and building experts.

From their Washington headquarters, the two associations have launched a concerted campaign through their state and regional affiliates to further the construction of demonstration dwellings in local communities, to pave the way for widespread construction of low cost homes in sections where the need is apparent.

Is Registration a Protective Measure?

It is claimed that architectural registration laws are enacted to protect the public against harm that might result from the design and construction of buildings by unqualified persons. That is the excuse for the law but probably not the real purpose. Most likely its real purpose is, in effect, an attempt to create a monopoly in the design of buildings for the benefit of architects. Incidentally as a part of the monopoly it is intended to prevent architects outside a state from competing within a state which has registration laws unless they also take out a license to become registered."

To show that this protective tariff idea is prevalent a quotation from a high official of one of the states may be cited as follows:

Louis C. Dunn, Inc.

GENERAL
CONTRACTORS

Monadnock Building
San Francisco

Phone: DOuglas 4632

Empire Construction Co., Ltd.

Builders



RUSS BUILDING
SAN FRANCISCO
SUtter 2989

Smith

Lumber Company
WHOLESALE - JOBBING - RETAIL
FACTORY AND BUILDING LUMBER
PLYWOODS - ROOFING
DISTRIBUTING YARDS

San Francisco	Oakland
•	19th Ave. &
4th & Channel	Estuary
MARKet 0103	FRuitvale 3174

YOUR INQUIRIES SOLICITED

We are surrounded by states which have strict architectural registration laws which make it imperative that the architects of this state protect themselves also with registration laws. Otherwise the architects from within our state would come over our state lines while architects from our state could not work in other states where such laws exist."

This seems to be a plain statement of what is probably the real purpose of registration laws and there does not seem to be much consideration for the safety of the "dear public" in it. Victor A. Matteson in Bulletin of the Illinois Society of Architects.

ABBOT A. HANKS, INC.
Engineers & Chemists

INSPECTING — TESTING — CONSULTING
CONCRETE • STEEL • MATERIALS
CHEMICAL AND TESTING
LABORATORIES
• RESEARCH AND INVESTIGATION •

TESTS OF STRUCTURAL MATERIALS
DESIGN OF CONCRETE MIXES
SHOP AND ERECTION INSPECTION OF
STRUCTURES AND EQUIPMENT
INVESTIGATION OF STRUCTURES
AND MATERIALS
TESTS AND INVESTIGATION OF
FOUNDATION SOILS
FIRE RESISTANCE AND INSULATION
TESTS

624 Sacramento Street, San Francisco

Phone GARfield 1164

Hunter & Hudson
Consulting Engineers

DESIGNERS OF HEATING
AIR CONDITIONING
VENTILATING AND WIRING
SYSTEMS, MECHANICAL
AND ELECTRICAL EQUIP-
MENT OF BUILDINGS

41 SUTTER STREET
ROOM 710

San Francisco California

DUN-PRIME

A Priming Paint
that makes satisfactory
2 Coat Work
possible on Redwood

Specify

DUN-PRIME

and notice the improved appearance
of your two coat jobs.

White - Ivory - Red - Gray

FRANK W. DUNNE CO.
41st and Linden Sts. Oakland, Cal.
MAKERS OF GOOD PAINT

VAUGHN - G. E. WITT Co.

Manufacturers and Distributors

Pump Governors	Oil Heaters
Safety Pump Governors	Relief Valves
Automatic Gas Regulating Valves	Oil Burner Governors
Gas Burning Equipment	Oil Burners
Vacuum Pump Governors	Oil Pumping Sets
Vacuum Regulating Valves	Oil Valves
Continuous Flow Steam Traps	Oil and Steam Strainers
Thermostats	Duplex Oil Pumps
Reducing Valves	Rotary Oil Pumps
	Boiler Feed Pumps
	Water Heaters
	Boiler Feed-Water Regulators

4224-28 Hollis St., Emeryville, Oakland

THE HERMANN SAFE CO.

MANUFACTURERS AND DEALERS
OF
FIRE AND BURGLAR PROOF
SAFES AND VAULTS, SAFE-
DEPOSIT BOXES, ETC.

200 HOWARD STREET
SAN FRANCISCO
GARfield 3041 - 3042

REPUBLIC STEEL CORPORATION



Manufacturers of

ENDURO Stainless Steel; TON-
CAN Copper Molybdenum Iron
Sheets and Pipe; and Steel Pipe,
Sheets and Reinforcing Bar for
every building purpose.

Write for information

Rialto Building, San Francisco, Calif.
Edison Building, Los Angeles, Calif.
White-Henry-Stuart Bldg., Seattle, Wash.

**VERMONT
MARBLE
COMPANY**

Producers and Finishers
of

Domestic and Imported
Marbles

San Francisco
Los Angeles
and
Tacoma, Wash.

Robert W. Hunt Company
ENGINEERS

Inspection - Tests - Consultation
Schools and Other Structures
Are Built as Designed

*When Construction Materials are
Inspected at point of Manufacture
and during Erection by*

ROBERT W. HUNT COMPANY

*Cement, Concrete, Chemical, Metallurgical,
X-Ray and Physical Laboratories*

Chicago - New York - Pittsburgh
Los Angeles - All Large Cities
San Francisco, 251 Kearny Street

**JOHN
CASSARETTO**

—Since 1886—And Still Active—

Building Materials

READY MIX CONCRETE
ROCK - SAND - GRAVEL - LIME
CEMENT - PLASTER - MORTAR
METAL LATH - WOOD LATH
STUCCO - WIRE NETTING

Service Unexcelled

Bunkers
Sixth and Channel, San Francisco
Phones: GARfield 3176, GARfield 3177

MERCURY PRESS

We Print
The ARCHITECT and
ENGINEER

*"A Thing of Beauty
Is a Joy Forever"*

942 HOWARD STREET
SAN FRANCISCO

**FINE WATER COLORS
AND PAPERS
FOR ARCHITECTURAL
RENDERINGS**

**H. S. CROCKER
COMPANY, Inc.**

720 MISSION STREET
MARKET STREET AT SECOND
SAN FRANCISCO

**THE TORMEY
COMPANY**

GENERAL PAINTERS
AND DECORATORS

Phone UNderhill 1913

563 FULTON STREET
San Francisco





